

Kinetix 6000 Multi-axis Servo Drives

Catalog Numbers

2094-ACxx-Mxx-S, 2094-BCxx-Mxx-S, 2094-AMxx-S, 2094-BMxx-S

2094-ACxx-Mxx, 2094-BCxx-Mxx, 2094-AMxx, 2094-BMxx,

2094-BSP2, 2094-PRF, 2094-SEPM-B24-S



Important User Information

Solid-state equipment has operational characteristics differing from those of electromechanical equipment. Safety Guidelines for the Application, Installation and Maintenance of Solid State Controls (publication [SGI-1.1](#) available from your local Rockwell Automation sales office or online at <http://www.rockwellautomation.com/literature/>) describes some important differences between solid-state equipment and hard-wired electromechanical devices. Because of this difference, and also because of the wide variety of uses for solid-state equipment, all persons responsible for applying this equipment must satisfy themselves that each intended application of this equipment is acceptable.

In no event will Rockwell Automation, Inc. be responsible or liable for indirect or consequential damages resulting from the use or application of this equipment.

The examples and diagrams in this manual are included solely for illustrative purposes. Because of the many variables and requirements associated with any particular installation, Rockwell Automation, Inc. cannot assume responsibility or liability for actual use based on the examples and diagrams.

No patent liability is assumed by Rockwell Automation, Inc. with respect to use of information, circuits, equipment, or software described in this manual.

Reproduction of the contents of this manual, in whole or in part, without written permission of Rockwell Automation, Inc., is prohibited.

Throughout this manual, when necessary, we use notes to make you aware of safety considerations.



WARNING: Identifies information about practices or circumstances that can cause an explosion in a hazardous environment, which may lead to personal injury or death, property damage, or economic loss.



ATTENTION: Identifies information about practices or circumstances that can lead to personal injury or death, property damage, or economic loss. Attentions help you identify a hazard, avoid a hazard, and recognize the consequence.



SHOCK HAZARD: Labels may be on or inside the equipment, for example, a drive or motor, to alert people that dangerous voltage may be present.



BURN HAZARD: Labels may be on or inside the equipment, for example, a drive or motor, to alert people that surfaces may reach dangerous temperatures.

IMPORTANT

Identifies information that is critical for successful application and understanding of the product.

Allen-Bradley, CompactLogix, ControlFLASH, ControlLogix, DriveExplorer, Guardmaster, HPK-Series, Integrated Architecture, Kinetix, LDC-Series, LDL-Series, Logix5000, MP-Series, RSLinx, RSLogix, SCANport, SoftLogix, RDD-Series, Rockwell Automation, Rockwell Software, Studio 5000, TechConnect, and TL-Series are trademarks of Rockwell Automation, Inc.

Trademarks not belonging to Rockwell Automation are property of their respective companies.

This manual contains new and updated information.

New and Updated Information

This table contains the changes made to this revision.

Topic	Page
Studio 5000™ Logix Designer application is the rebranding of RSLogix™ 5000 software. General references to RSLogix 5000 software have been replaced by the Logix Designer application. References to specific RSLogix 5000 software versions did not change.	12
Updated references to safe-off (SO) as safe torque-off (STO), per EN61800-5-2.	Throughout this manual
Updated references to series A and B drives. The 230V drive modules previously labeled as series A are now series A and C. The 460V drives previously labeled as series B are now series B and C.	Throughout this manual
Added LDAT-Series linear thrusters to system overview table.	16
Added LDAT-Series linear thrusters to typical system installation diagrams.	17...18
Updated System Mounting Requirements for enclosure rating from IP2x to IP54.	26
Added AC line filter selection table.	27
Updated safe torque-off (STO) connector pinout table with series C descriptions for safety enable inputs.	60
Updated motor/resistive brake circuitry diagram and text with changes for the new solid-state relay.	71
Added the LDAT-Series linear thruster interconnect diagram with Kinetix® 6000 drive.	207
Added the Configure the Load Observer Feature appendix.	235

Notes:

	Preface	
	About This Publication.....	11
	Audience.....	11
	Conventions Used in This Manual.....	11
	Studio 5000 Environment.....	12
	Additional Resources.....	12
	 Chapter 1	
Start	IAM/AM Module Series Changes.....	15
	About the Kinetix 6000 Drive Systems.....	16
	Typical Hardware Configurations.....	17
	Typical Communication Configurations.....	21
	Catalog Number Explanation.....	22
	Kinetix Drive Component Compatibility.....	23
	Kinetix 6000M Integrated Drive-Motor System Compatibility.....	23
	Agency Compliance.....	24
	CE Requirements (system without LIM module).....	24
	CE Requirements (system with LIM module).....	24
	 Chapter 2	
Planning the Kinetix 6000 Drive System Installation	System Design Guidelines.....	26
	System Mounting Requirements.....	26
	Transformer Selection.....	27
	AC Line Filter Selection.....	27
	Circuit Breaker/Fuse Options.....	28
	Enclosure Selection.....	30
	Minimum Clearance Requirements.....	33
	Electrical Noise Reduction.....	34
	Bonding Modules.....	34
	Bonding Multiple Subpanels.....	36
	Establishing Noise Zones.....	37
	Cable Categories for Kinetix 6000 Systems.....	45
	Noise Reduction Guidelines for Drive Accessories.....	47
	 Chapter 3	
Mounting the Kinetix 6000 Drive System	Before You Begin.....	51
	Using the 2094 Mounting Brackets.....	51
	Installing the 2094 Power Rail.....	52
	Determine Mounting Order.....	52
	Mount Modules on the Power Rail.....	54

Connector Data and Feature Descriptions

Chapter 4

2094 IAM/AM Module Connector Data 58

 Safe Torque-off Connector Pinout 60

 I/O Connector Pinout 61

 Motor Feedback Connector Pinout 62

 Auxiliary Feedback Connector Pinout 64

 IAM Input Connector Pinout 65

 IAM and AM Motor Power and Brake Connector Pinout 66

Control Signal Specifications 67

 Digital Inputs 67

 Sercos Communication Specifications 68

 Analog Outputs 69

 Contactor Enable Relay 70

Power and Relay Specifications 71

 Motor/Resistive Brake Relay 71

 Input Power Cycle Capability 72

 Peak Enhancement Specifications 73

 Control Power 76

Feedback Specifications 77

 Absolute Position Feature 77

 Motor Feedback Specifications 78

 Feedback Power Supply Specifications 79

 Auxiliary Position Feedback Encoders 80

Connecting the Kinetix 6000 Drive System

Chapter 5

Basic Wiring Requirements 81

 Building Your Own Cables 82

 Routing the Power and Signal Cables 82

Determine the Input Power Configuration 83

 Grounded Power Configurations 83

 Ungrounded and High-impedance Grounded Power Configurations 85

DC Common Bus Configurations 86

 Common Bus Fusing Requirements 87

Setting the Ground Jumper in Ungrounded Power Configurations ... 87

 Set the Ground Jumper 88

Grounding the Kinetix 6000 Drive System 93

 Ground the Power Rail to the System Subpanel 93

 Ground Multiple Subpanels 94

Power Wiring Requirements 95

Power Wiring Guidelines 97

Wiring the IAM/AM Module Connectors 98

 Wire the Control Power (CPD) Connector 98

 Wire the Input Power (IPD) Connector 99

 Wire the Contactor Enable (CED) Connector 101

 Wiring the Safe Torque-off (STO) Connector 102

Wire the Motor Power (MP) Connector	103
Wire the Motor/Resistive Brake (BC) Connector.....	111
Apply the Motor Cable Shield Clamp.....	114
Feedback and I/O Cable Connections	115
Flying-lead Feedback Cable Pinouts.....	117
Wiring the Feedback and I/O Connectors	120
Connect Premolded Motor Feedback Cables	120
Connect Panel-mounted Breakout Board Kits	121
Wire Low-profile Connector Kits	122
External Shunt Module Connections	125
IPIM Module Connections	126
RBM Module Connections	127
Sercos Fiber-optic Cable Connections	128
Kinetix 6000M Integrated Drive-Motor Sercos Connections	131
Ethernet Cable Connections	132

Chapter 6

Configure and Start the Kinetix 6000 Drive System

Configure the Kinetix 6000M Integrated Drive-Motor System	133
Configure the Drive Modules	134
Configure the Logix5000 Sercos interface Module	140
Configure the Logix5000 Controller.....	140
Configure the Logix5000 Module	142
Configure the Kinetix 6000 Drive Modules.....	144
Configure the Motion Group	148
Configure Axis Properties.....	149
Download the Program	152
Apply Power to the Kinetix 6000 Drive	153
Test and Tune the Axes.....	155
Test the Axes	155
Tune the Axes.....	157
Configure Drive Parameters and System Variables	160
Tools for Changing Parameters.....	160
Monitor System Variables with Analog Test Points	161

Chapter 7

Troubleshooting the Kinetix 6000 Drive System

Safety Precautions.....	163
Interpret Status Indicators.....	164
Kinetix 6000M IDM System Error Codes	164
Kinetix 6000 Drive System Error Codes.....	165
IAM/AM Module Status Indicators	170
Shunt Module Status Indicators	171
General System Anomalies.....	173
Logix5000/Drive Fault Behavior	175

	Chapter 8	
Removing and Replacing the Kinetix 6000 Drive Modules	Before You Begin	179
	Remove Kinetix 6000 Drive Modules	180
	Replace Kinetix 6000 Drive Modules	181
	Remove the Power Rail	182
	Replace the Power Rail	183
	Appendix A	
Interconnect Diagrams	Interconnect Diagram Notes	186
	Power Wiring Examples	187
	DC Common Bus Wiring Examples	191
	Shunt Module Wiring Examples	195
	Axis Module/Rotary Motor Wiring Examples	196
	Axis Module/Linear Motor/Actuator Wiring Examples	205
	Kinetix 6000M Integrated Drive-Motor Wiring Example	210
	Controlling a Brake Example	211
	System Block Diagrams	212
	Appendix B	
Upgrading the Drive Firmware	Upgrade Kinetix 6000M System Firmware	215
	Upgrade Drive Firmware with ControlFLASH Software	216
	Before You Begin	216
	Configure Logix5000 Communication	217
	Upgrade Firmware	219
	Verify the Firmware Upgrade	223
	Appendix C	
DC Common Bus Applications	Before You Begin	225
	Calculate Total Bus Capacitance	226
	Calculate Additional Bus Capacitance	227
	Bulletin 2094 Drive Capacitance Values	227
	Common Bus Capacitance Example	228
	Set the Additional Bus Capacitance Parameter	229
	Remove Sercos Communication	229
	Set the Additional Bus Capacitance Parameter	230
	Save the Add Bus Cap Parameter to Nonvolatile Memory	231
	Verify the Parameter Changes	232
Reconnect Sercos Communication	233	

	Appendix D	
Configure the Load Observer Feature	Benefits	235
	How it Works	235
	Configuration	236
	Out-of-Box Gain Settings	239
	Auto-tune Gain Settings	241
	Tuning Mode Summary	244
	Manual Tuning for Further Optimization	244
	Setting Gains with Sercos IDN Write Messages	246
	Compensate for High Frequency Resonances	247
	Appendix E	
Changing the Default IDN Parameter Values	Before You Begin	249
	Change IDN Parameter Values	250
	Read the Present IDN Parameter Value	250
	Calculate the New IDN Value	252
	Write the New IDN Parameter Value	253
	Appendix F	
Enhanced Peak Performance	Before You Begin	255
	Enhanced Peak Example	257
	Enhanced Peak Example Calculation	260
	Change the Drive Parameter	262
	Sercos IDN Write Instruction	262
	DriveExplorer Software	263
	Appendix G	
RBM Module Interconnect Diagrams	Before You Begin	265
	RBM Module Wiring Examples	266
	Index	

Notes:

About This Publication

This manual provides detailed installation instructions for mounting, wiring, and troubleshooting Kinetix 6000 drives; and system integration for your drive and motor/actuator combination with a Logix controller.

For information on wiring and troubleshooting your Kinetix 6000 servo drive with the safe torque-off feature, refer to the Kinetix Safe Torque-off Feature Safety Reference Manual, publication [GMC-RM002](#).

Audience

This manual is intended for engineers or technicians directly involved in the installation and wiring of the Kinetix 6000 drives; and programmers directly involved in the operation, field maintenance, and integration of these drives with a sercos interface module.

If you do not have a basic understanding of the Kinetix 6000 drives, contact your local Rockwell Automation sales representative for information on available training courses.

Conventions Used in This Manual

The conventions starting below are used throughout this manual.

- Bulleted lists such as this one provide information, not procedural steps.
- Numbered lists provide sequential steps or hierarchical information.
- Acronyms for the Kinetix 6000 drive modules are shown in the table below and are used throughout this manual.

Kinetix 6000 Drive Modules	Cat. No.	Acronym
Integrated Axis Module	2094-xCxx-Mxx-x	IAM
Axis Module	2094-xMxx-x	AM
Line Interface Module	2094-xLxx and 2094-xLxxS-xx	LIM
Resistive Brake Module	2090-XBxx-xx	RBM

Kinetix 6000M Drive Modules	Cat. No.	Acronym
Integrated Drive-Motor	MDF-SBxxxxx	IDM
IDM Power Interface Module	2094-SEPM-B24-S	IPIM

IMPORTANT Throughout this publication, when the IAM or AM module catalog number is followed by -x, for example 2094-BMP5-x, the variable (x) indicates that the drive module may or may not include the safe torque-off feature.

Studio 5000 Environment

The Studio 5000 Engineering and Design Environment combines engineering and design elements into a common environment. The first element in the Studio 5000 environment is the Logix Designer application. The Logix Designer application is the rebranding of RSLogix 5000 software and will continue to be the product to program Logix5000 controllers for discrete, process, batch, motion, safety, and drive-based solutions.



The Studio 5000 environment is the foundation for the future of Rockwell Automation® engineering design tools and capabilities. It is the one place for design engineers to develop all the elements of their control system.

Additional Resources

These documents contain additional information concerning related products from Rockwell Automation.

Table 1 - Additional Resources

Resource	Description
Line Interface Module Installation Instructions, publication 2094-IN005	Provides information on the installation and troubleshooting of Bulletin 2094 line interface modules (LIM).
2094 Mounting Bracket Installation Instructions, publication 2094-IN008	Provides information on the installation of Bulletin 2094 mounting brackets.
Resistive Brake Module Installation Instructions, publication 2090-IN009	Provides information on the installation and wiring of Bulletin 2090 Resistive Brake Modules.
Fiber-optic Cable Installation and Handling Instructions, publication 2090-IN010	Provides information on proper handling, installing, testing, and troubleshooting fiber-optic cables.
External Shunt Modules Installation Instructions, publication 2090-IN004	Provides information on mounting and wiring the Bulletin 1394 shunt modules with Bulletin 2094 servo drive systems.
System Design for Control of Electrical Noise Reference Manual, publication GMC-RM001	Provides information, examples, and techniques designed to minimize system failures caused by electrical noise.
EMC Noise Management DVD, publication GMC-SP004	
Kinetix 6000M Integrated Drive-Motor User Manual, publication 2094-UM003	Provides information on installing, configuring, startup, troubleshooting, and applications for your Kinetix 6000M integrated drive-motor (IDM) system.
Kinetix Safe Torque-off Feature Safety Reference Manual, publication GMC-RM002	Provides information on wiring and troubleshooting your Kinetix 6000 servo drives with the safe torque-off feature.

Table 1 - Additional Resources (continued)

Resource	Description
Kinetix Motion Control Selection Guide, publication GMC-SG001	Provides overview of Kinetix servo drives, motors, actuators, and motion accessories designed to help make initial decisions for the motion control products best suited for your system requirements.
Kinetix 6000 and Kinetix 6200/6500 Drive Systems Design Guide, publication GMC-RM003	Provides information to determine and select the required (drive specific) drive module, power accessory, connector kit, motor cable, and interface cable catalog numbers for your drive and motor/actuator motion control system. Includes system performance specifications and torque/speed curves (rotary motion) and force/velocity curves (linear motion) for your motion application.
Kinetix Rotary Motion Specifications Technical Data, publication GMC-TD001	Provides product specifications for MP-Series™ (Bulletin MPL, MPM, MPF, MPS), Kinetix 6000M (Bulletin MDF), TL-Series™, RDD-Series™, and HPK-Series™ rotary motors.
Kinetix Linear Motion Specifications Technical Data, publication GMC-TD002	Provides product specifications for Bulletin MPAS and MPMA linear stages, Bulletin MPAR, MPAL, and TLAR electric cylinders, and LDC-Series™ and LDL-Series™ linear motors.
Kinetix Servo Drives Specifications Technical Data, publication GMC-TD003	Provides product specifications for Kinetix Integrated Motion over the EtherNet/IP network, Integrated Motion over sercos interface, EtherNet/IP networking, and component servo drive families.
Kinetix Motion Accessories Specifications Technical Data, publication GMC-TD004	Provides product specifications for Bulletin 2090 motor and interface cables, low-profile connector kits, drive power components, and other servo drive accessory items.
Download Motion Analyzer software from: http://www.ab.rockwellautomation.com/motion-control/motion-analyzer-software	Comprehensive motion application sizing tool used for analysis, optimization, selection, and validation of your Kinetix Motion Control system.
Rockwell Automation Configuration and Selection Tools, website http://www.ab.com	Provides online product selection and system configuration tools, including AutoCad (DXF) drawings.
Rockwell Automation Product Certification, website http://www.rockwellautomation.com/products/certification	For declarations of conformity (DoC) currently available from Rockwell Automation.
Sercos and Analog Motion Configuration User Manual, publication MOTION-UM001	Provides information on configuring and troubleshooting your ControlLogix®, CompactLogix™, and SoftLogix™ sercos interface modules.
Motion Coordinate System User Manual, publication MOTION-UM002	Provides information to create a motion coordinate system with sercos or analog motion modules.
Integrated Motion on the EtherNet/IP Network Configuration and Startup User Manual, publication MOTION-UM003	Provides information on configuring and troubleshooting your ControlLogix and CompactLogix EtherNet/IP network modules.
SoftLogix Motion Card Setup and Configuration Manual, publication 1784-UM003	Provides information on configuring and troubleshooting SoftLogix PCI cards.
ControlFLASH Firmware Upgrade Kit User Manual, publication 1756-QS105	For ControlFLASH™ information not specific to any drive family.
National Electrical Code, published by the National Fire Protection Association of Boston, MA	An article on wire sizes and types for grounding electrical equipment.
Rockwell Automation Industrial Automation Glossary, publication AG-7.1	A glossary of industrial automation terms and abbreviations.

You can view or download publications at <http://www.rockwellautomation.com/literature>. To order paper copies of technical documentation, contact your local Allen-Bradley distributor or Rockwell Automation sales representative.

Notes:

Start

Use this chapter to become familiar with the design and installation requirements for Kinetix 6000 drive systems.

Topic	Page
IAM/AM Module Series Changes	15
About the Kinetix 6000 Drive Systems	16
Typical Hardware Configurations	17
Typical Communication Configurations	21
Catalog Number Explanation	22
Kinetix Drive Component Compatibility	23
Kinetix 6000M Integrated Drive-Motor System Compatibility	23
Agency Compliance	24

IAM/AM Module Series Changes

Series B drives included the peak current enhancement and applied to only the 460V (series A) IAM and AM modules. The peak current ratings of the Kinetix 6000 (460V) drives are configured at the factory as 150% of continuous current. However, you can program 460V AM modules and the equivalent IAM (inverter) modules, for up to 250% of continuous inverter current.

Table 2 - Kinetix 6000 Enhanced Peak Performance Series Change

IAM Module Cat. No.	AM Module Cat. No.	Peak Current Rating	
		Series A (inverter)	Series B and C (inverter)
2094-BC01-MP5-S	2094-BMP5-S	150%	250%
2094-BC01-M01-S	2094-BM01-S	150%	250%
2094-BC02-M02-S	2094-BM02-S	150%	250%
2094-BC04-M03-S	2094-BM03-S	150%	250%
2094-BC07-M05-S	2094-BM05-S	150%	200%

IMPORTANT

Before your drive can deliver enhanced peak performance, you must enable the peak enhancement feature by configuring your drive with DriveExplorer™ software or the Logix Designer application.

Refer to [Appendix F on page 255](#) to recalculate torque and acceleration or deceleration limit values, and paste them into the appropriate Axis Properties dialog box in the Logix Designer application.

For more information on setting axis properties, refer to [Configure Axis Properties on page 149](#).

In series C drives, a mechanical relay for the brake circuit and another for the safe torque-off inputs are replaced by solid-state relays and apply to the 230V (series A) and 460V (series B) IAM and AM modules. All wiring is consistent with previous series releases.

About the Kinetix 6000 Drive Systems

The Kinetix 6000 multi-axis servo drives are designed to provide a Kinetix Integrated Motion solution for your drive/motor/actuator applications.

Table 3 - Kinetix 6000 Drive System Overview

System Component	Cat. No.	Description
Integrated Axis Module	2094-xCxx-Mxx-S ⁽¹⁾⁽²⁾	Integrated Axis Modules (IAM) with the safe torque-off feature with 200V or 400V-class AC input power. Contains an inverter and converter section. The peak enhancement feature is available on 400V-class (series B and C) IAM modules.
	2094-xCxx-Mxx	Integrated Axis Modules (IAM), with 200V or 400V-class AC input power (does not include the safe torque-off or peak-enhanced feature). Contains an inverter and converter section.
Axis Module	2094-xMxx-S ⁽¹⁾⁽²⁾	Axis Modules (AM) with safe torque-off are shared DC-bus inverters and rated for 200 or 400V-class operation. The AM module must be used with an IAM module. The peak enhancement feature is available on 400V-class (series B and C) AM modules.
	2094-xMxx	Axis Modules (AM) are shared DC-bus inverters rated for 200V or 400V-class input power (does not include the safe torque-off or peak-enhanced feature). The AM module must be used with an IAM module.
Shunt Module	2094-BSP2	The Bulletin 2094 shunt module mounts to the power rail and provides additional shunting in regenerative applications.
Kinetix 6000M IDM System	2094-SEPM-B24-S Bulletin MDF	The Kinetix 6000M integrated drive-motor (IDM) system consists of the IDM power interface module (IPIM) and up to 16 (Bulletin MDF) IDM units. The IPIM module mounts on the Bulletin 2094 power rail and provides power and communication to the IDM units. The IPIM module also monitors power output and provides overload protection.
Power Rail	2094-PRs 2094-PRx	The Bulletin 2094 power rail consists of copper bus bars and a circuit board with connectors for each module. The power rail provides power and control signals from the converter section to adjacent inverters. The IAM and AM power modules, shunt module, slot-filler modules mount to the power rail.
Slot-filler Module	2094-PRF	The Bulletin 2094 slot-filler module is used when one or more slots on the power rail are empty after all the other power rail modules are installed. One slot-filler module is required for each empty slot.
Logix5000™ Controllers	1756-MxxSE modules 1768-M04SE module 1784-PM16SE PCI card	The sercos interface module/PCI card serves as a link between the ControlLogix/CompactLogix/SoftLogix controllers and the Kinetix 6000 drive system. The communication link uses the IEC 61491 Serial Real-time COmmunication System (sercos) protocol over a fiber-optic cable.
	1756-ENxTx modules CompactLogix 5370 controllers	The Kinetix 6000M IPIM module connects to the EtherNet/IP network for monitoring, diagnostics, and firmware upgrades.
Studio 5000 Environment	9324-RDL300xxE	The Logix Designer application provides support for programming, commissioning, and maintaining the Logix5000 family of controllers.
Rotary Servo Motors	MP-Series, TL-Series, RDD-Series, 1326AB, F-Series	Compatible rotary motors include the MP-Series (Bulletin MPL, MPM, MPF, and MPS) 200V and 400V-class motors; RDD-Series; TL-Series; 1326AB (M2L/S2L) and 1326AB (resolver); and F-Series motors.
Linear Motors	LDC-Series, LDL-Series	Compatible motors include LDC-Series iron core (200V and 400V-class) and LDL-Series ironless (200V-class) linear motors.
Linear Actuators	MP-Series	Compatible actuators include MP-Series (200V and 400V-class) Bulletin MPAS single-axis and Bulletin MPMA multi-axis integrated linear stages, and MP-Series (200V and 400V-class) Bulletin MPAR and MPAL electric cylinders.
	LDAT-Series	LDAT-Series integrated linear actuators are compatible with 200V and 400V-class drive systems.
Cables	2090-Series motor/actuator cables	Bulletin 2090 motor/actuator cables are available with bayonet, threaded, and SpeedTec connectors. Power/brake cables have flying leads on the drive end and straight connectors that connect to servo motors. Feedback cables have flying leads that wire to low-profile connector kits on the drive end and straight connectors on the motor end.
	Kinetix 6000M integrated drive-motor cables	Bulletin 2090 integrated drive-motor (IDM) hybrid and network cables connect between the 2094 IPIM module and the Kinetix 6000M IDM units. Bulletin 889D and 879D cables connect between digital input connectors and sensors.
	Communication	Bulletin 2090 sercos fiber-optic cables are available as enclosure only, PVC, nylon, and glass with connectors at both ends. Ethernet cables are available in standard lengths for Kinetix 6000M IPIM modules. Shielded cable is recommended.
AC Line Filters	2090-XXLF-xxxx	Bulletin 2090-XXLF-xxxx three-phase AC line filters are required to meet CE in all 200V and 400V-class drive systems.
Line Interface Modules	2094-xLxx 2094-xLxxS 2094-XL75S-Cx	Line interface modules (LIM) include the circuit breakers, AC line filter (catalog numbers 2094-AL09 and 2094-BL02 only), power supplies, and safety contactor required for Kinetix 6000 operation. The LIM module does not mount to the power rail. You can purchase individual components separately in place of the LIM module.
External Shunt Modules	1394-SRxxxx	You can use Bulletin 1394 external passive shunt modules when the IAM/AM module internal shunt and power rail mounted 2094-BSP2 shunt module capability is exceeded.
Resistive Brake Module	2090-XBxx-xx	Resistive Brake Modules (RBM) include a safety contactor for use in a control circuit. Contactors and resistors reside in this module such that the motor leads can be disconnected from the drive with the permanent magnet motor brought to an immediate stop. This module does not mount to the power rail.

(1) Refer to the Kinetix Safe Torque-off Feature Safety Reference Manual, publication [GMC-RM002](#), for more information.

(2) Refer to Peak Enhancement Specifications on [page 73](#) for more information on drive performance in the Peak-enhanced mode.

Typical Hardware Configurations

Typical Kinetix 6000 system installations include three-phase AC configurations, with and without the line interface module (LIM), and DC common-bus configurations.



SHOCK HAZARD: To avoid personal injury due to electrical shock, place a 2094-PRF slot-filler module in all empty slots on the power rail. Any power rail connector without a module installed disables the Bulletin 2094 system; however, control power is still present.

Figure 1 - Typical Kinetix 6000 System Installation (with LIM)

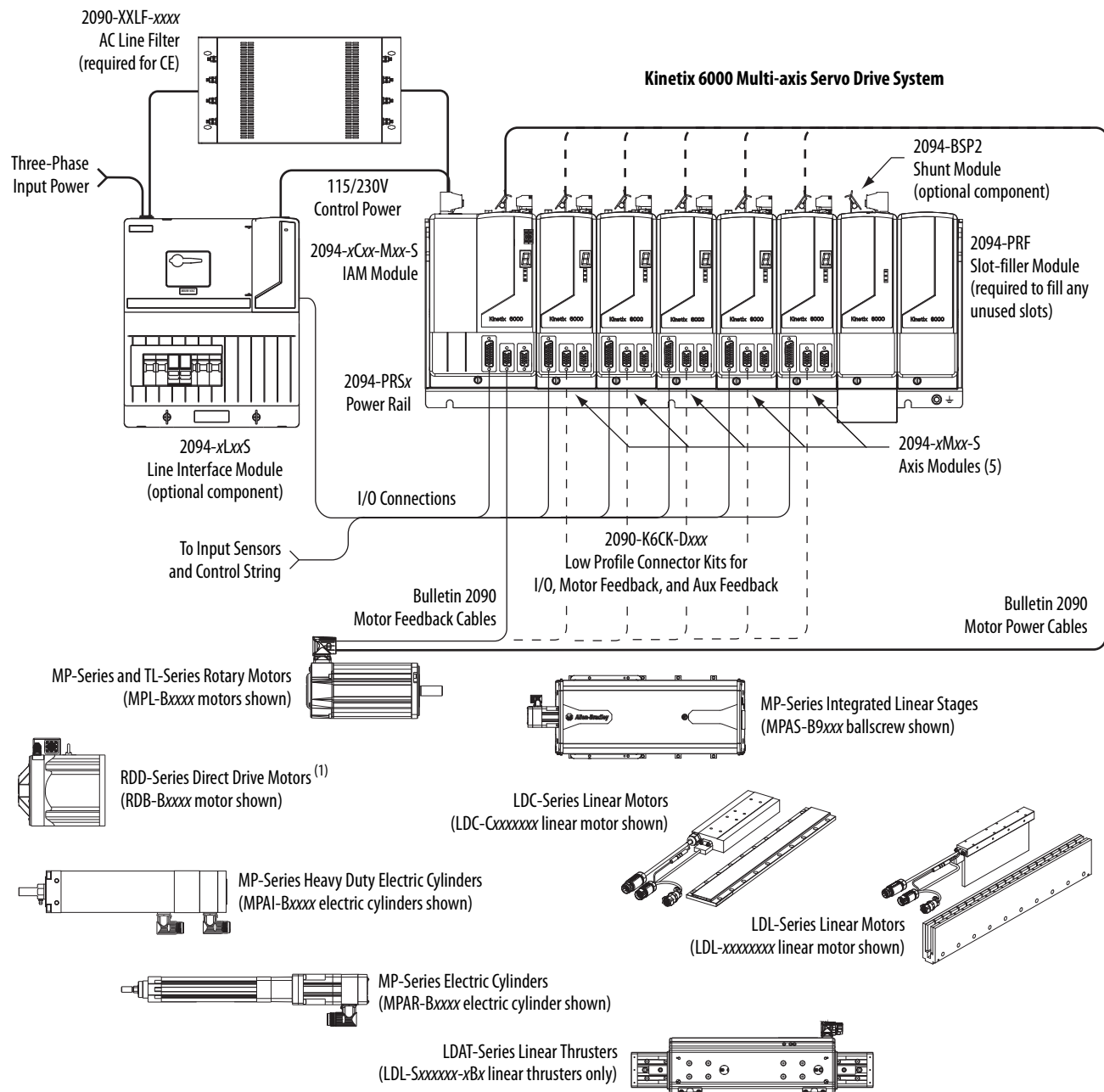

(1) RDD-Series direct-drive motors require the 2090-K6CK-KENDAT low-profile feedback module.

Figure 2 - Typical Kinetix 6000 System Installation (without LIM)

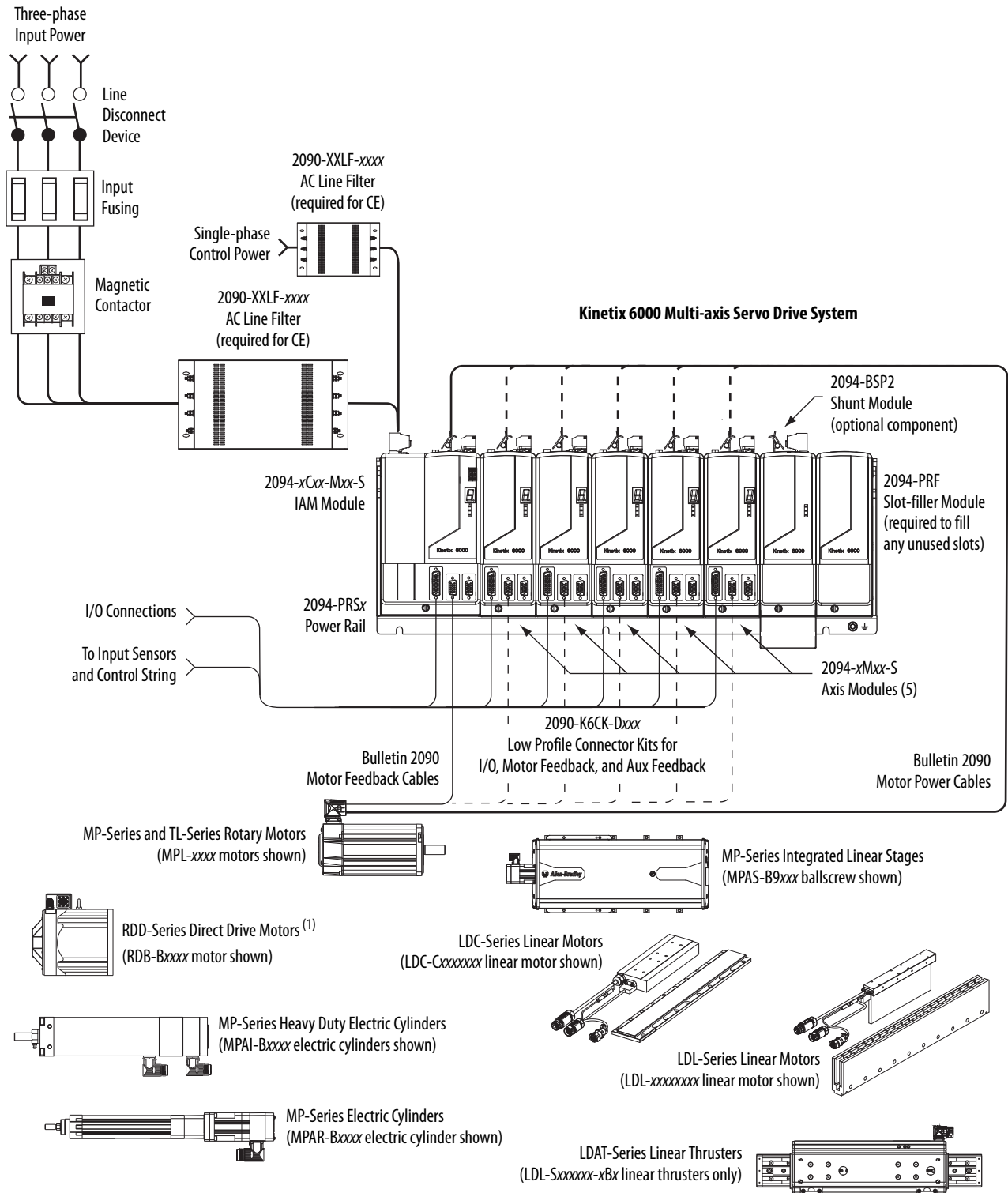

(1) RDD-Series direct-drive motors require the 2090-K6CK-KENDAT low-profile feedback module.

This configuration illustrates the Kinetix 6000M integrated drive-motor (IDM) system with IDM power interface module (IPIM) installed on the Bulletin 2094 power rail. The IPIM module is included in the drive-to-drive fiber-optic cable installation along with the axis modules.

Figure 3 - Typical Kinetix 6000M Integrated Drive-Motor System Installation

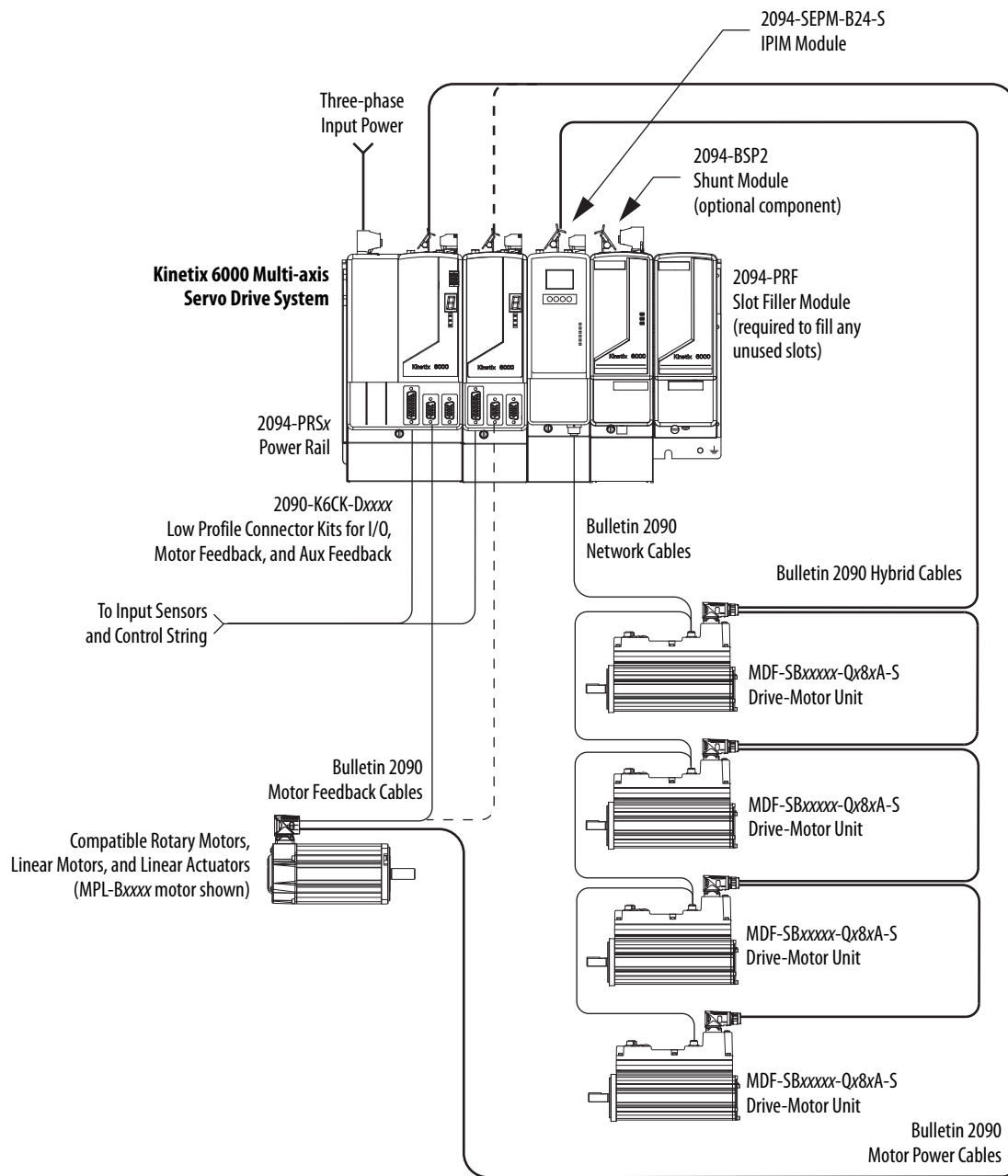

For more information on Kinetix 6000M integrated drive-motor system installation, refer to the Kinetix 6000M Integrated Drive-Motor System User Manual, publication [2094-UM003](#).

Figure 4 - Typical (400V-class) DC Common Bus System Installation

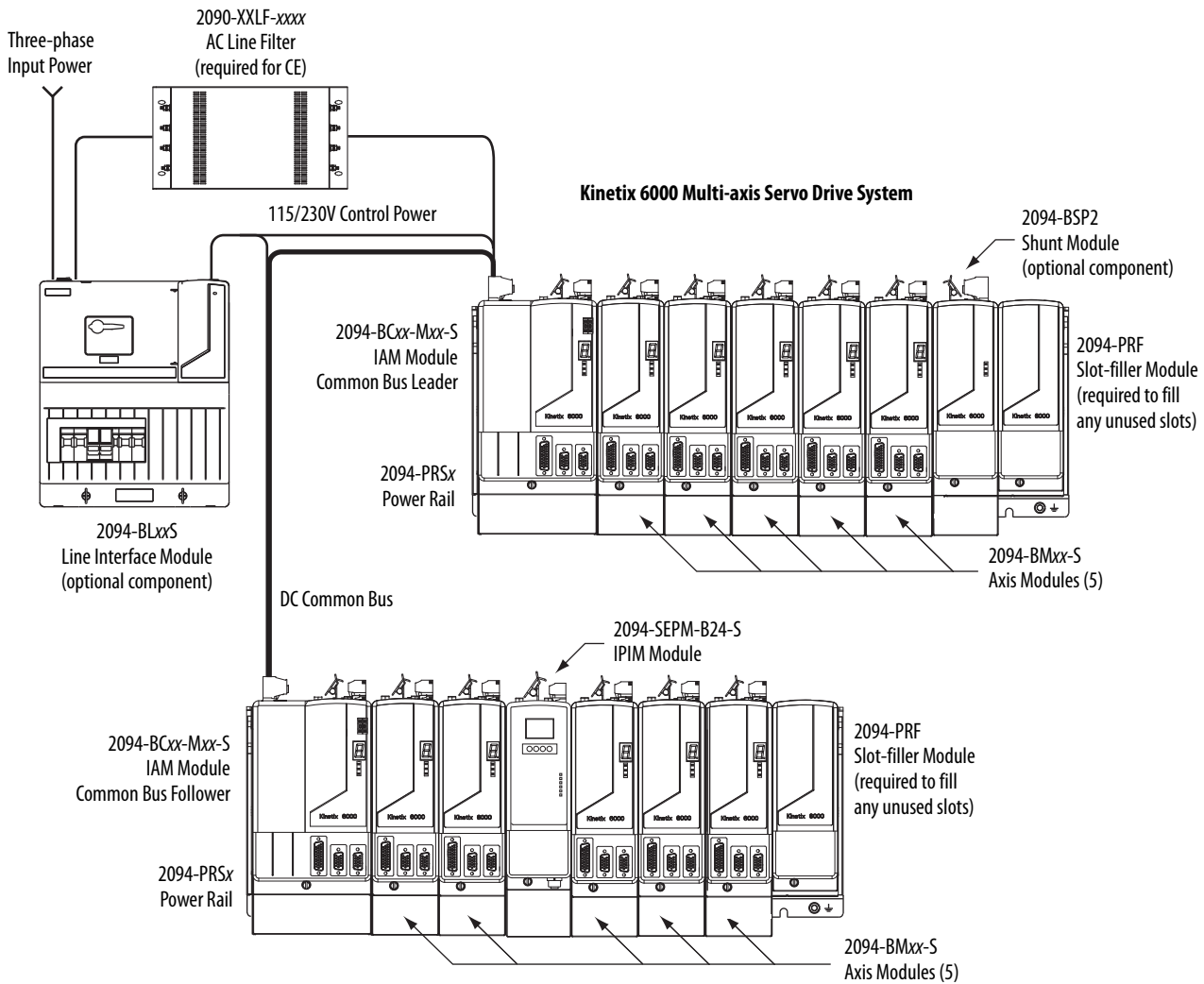

In the example above, the leader IAM module is connected to the follower IAM module via the DC common-bus. The follower system also includes the Kinetix 6000M integrated drive-motor (IDM) power interface module (IPIM) that supports up to 16 IDM units.

When planning your panel layout, you must calculate the total bus capacitance of your DC common-bus system to be sure that the leader IAM module is sized sufficiently to pre-charge the entire system. Refer to [Appendix C](#), beginning on [page 225](#), for more information.

IMPORTANT

If total bus capacitance of your system exceeds the leader IAM module pre-charge rating and input power is applied, the IAM module seven-segment status indicator displays error code E90 (pre-charge timeout fault).

To correct this condition, you must replace the leader IAM module with a larger module or decrease the total bus capacitance by removing the IPIM module or AM modules.

Typical Communication Configurations

In this example, drive-to-drive sercos cables and catalog numbers are shown when Kinetix 6000, Kinetix 6000M, and Kinetix 6200 drive modules exist on the same power rail.

The Kinetix 6200 control modules use sercos interface for configuring the Logix5000 module and the EtherNet/IP network for diagnostics and configuring safety functions. An Ethernet cable is connected to each control module during safety configuration. For more information on Ethernet cables, refer to the Industrial Ethernet Media Brochure, publication [1585-BR001](#).

Figure 5 - Typical Kinetix 6000 and Kinetix 6200 Communication (sercos)

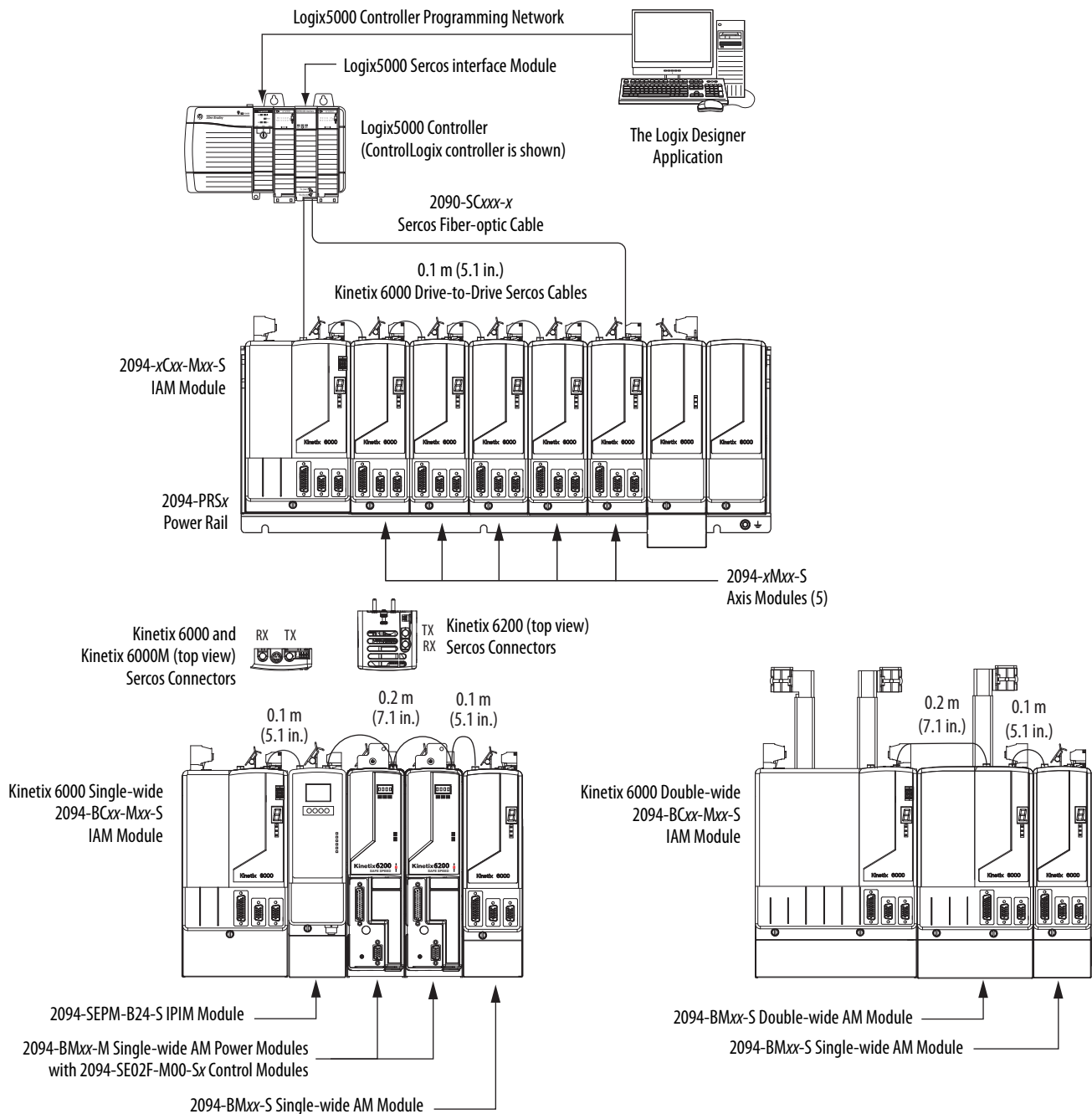

Catalog Number Explanation

Kinetix 6000 (Bulletin 2094) drive catalog numbers and descriptions are listed in the tables below.

IMPORTANT Throughout this publication, when the IAM or AM module catalog number is followed by -x, for example 2094-BMP5-x, the variable (x) indicates that the drive module may or may not include the safe torque-off feature.

Table 4 - Kinetix 6000 Drive Catalog Numbers

Integrated Axis Modules (230V)	Cat. No. (with safe torque-off feature)	Cat. No. (without safe torque-off feature)
Kinetix 6000, IAM, 200V-class, 3 kW converter, 5 A inverter	2094-AC05-MP5-S	2094-AC05-MP5
Kinetix 6000, IAM, 200V-class, 3 kW converter, 9 A inverter	2094-AC05-M01-S	2094-AC05-M01
Kinetix 6000, IAM, 200V-class, 6 kW converter, 15 A inverter	2094-AC09-M02-S	2094-AC09-M02
Kinetix 6000, IAM, 200V-class, 11 kW converter, 24 A inverter	2094-AC16-M03-S	2094-AC16-M03
Kinetix 6000, IAM, 200V-class, 23 kW converter, 49 A inverter	2094-AC32-M05-S	2094-AC32-M05
Integrated Axis Modules (460V)		
Kinetix 6000, IAM, 400V-class, 6 kW converter, 4 A inverter	2094-BC01-MP5-S ⁽¹⁾	2094-BC01-MP5
Kinetix 6000, IAM, 400V-class, 6 kW converter, 9 A inverter	2094-BC01-M01-S ⁽¹⁾	2094-BC01-M01
Kinetix 6000, IAM, 400V-class, 15 kW converter, 15 A inverter	2094-BC02-M02-S ⁽¹⁾	2094-BC02-M02
Kinetix 6000, IAM, 400V-class, 28 kW converter, 30 A inverter	2094-BC04-M03-S ⁽¹⁾	2094-BC04-M03
Kinetix 6000, IAM, 400V-class, 45 kW converter, 49 A inverter	2094-BC07-M05-S ⁽²⁾	2094-BC07-M05
Axis Modules (230V)		
Kinetix 6000, AM, 200V-class, 5 A	2094-AMP5-S	2094-AMP5
Kinetix 6000, AM, 200V-class, 9 A	2094-AM01-S	2094-AM01
Kinetix 6000, AM, 200V-class, 15 A	2094-AM02-S	2094-AM02
Kinetix 6000, AM, 200V-class, 24 A	2094-AM03-S	2094-AM03
Kinetix 6000, AM, 200V-class, 49 A	2094-AM05-S	2094-AM05
Axis Modules (460V)		
Kinetix 6000, AM, 400V-class, 4 A	2094-BMP5-S ⁽¹⁾	2094-BMP5
Kinetix 6000, AM, 400V-class, 9 A	2094-BM01-S ⁽¹⁾	2094-BM01
Kinetix 6000, AM, 400V-class, 15 A	2094-BM02-S ⁽¹⁾	2094-BM02
Kinetix 6000, AM, 400V-class, 30 A	2094-BM03-S ⁽¹⁾	2094-BM03
Kinetix 6000, AM, 400V-class, 49 A	2094-BM05-S ⁽²⁾	2094-BM05

(1) You can configure the peak inverter current rating of this 460V (series B and C) IAM or AM module for 250% of continuous inverter current.

(2) You can configure the peak inverter current rating of this 460V (series B and C) IAM or AM module for 200% of continuous inverter current. Refer to [Peak Enhancement Specifications](#) on [page 73](#), for more information on drive performance in the peak-enhanced mode.

Table 5 - Kinetix 6000 Drive Component Catalog Numbers

Drive Components	Cat. No.
Integrated power interface (IPIM) module, 400V-class, 15 kW, 24 A (rms)	2094-SEPM-B24-S
Kinetix 6000 shunt module, 200/400V-class, 200 W	2094-BSP2
Kinetix 6000 slot-filler module, 200/400V-class	2094-PRF

Kinetix Drive Component Compatibility

The 2094-BC $_{xx}$ -M $_{xx}$ -M and 2094-BM $_{xx}$ -M power modules contain the same power structure as the 2094-BC $_{xx}$ -M $_{xx}$ -S and 2094-BM $_{xx}$ -S drive modules. Because of this, the 2094-BSP2 shunt module, 2094-PRF slot-filler module, and 2094-PR $_{Sx}$ power rails are supported by both drive families.

In addition, 2094-BM $_{xx}$ -M AM power modules with sercos interface are supported on power rails with a 2094-BC $_{xx}$ -M $_{xx}$ -S IAM drive module. Conversely, 2094-BM $_{xx}$ -S AM drive modules are supported on power rails with a 2094-BC $_{xx}$ -M $_{xx}$ -M IAM power module with sercos interface.

IMPORTANT Kinetix 6500 EtherNet/IP control modules (catalog numbers 2094-EN02D-M01-S $_{x}$) are not compatible with IAM/AM modules on the same Bulletin 2094 power rail with Kinetix 6000 or Kinetix 6200 sercos drives.

Table 6 - IAM and AM Module/Network Compatibility

IAM Module	Control Module	2094-xM $_{xx}$ -S Kinetix 6000 AM Module	2094-BM $_{xx}$ -M AM Power Modules	
			2094-SE02F-M00-S $_{x}$ Kinetix 6200 Control Module	2094-EN02D-M01-S $_{x}$ Kinetix 6500 Control Module
2094-xC $_{xx}$ -M $_{xx}$ -S	N/A	Fully compatible	Fully compatible	Not compatible
2094-BC $_{xx}$ -M $_{xx}$ -M (IAM power module)	2094-SE02F-M00-S $_{x}$ sercos interface			
		2094-EN02D-M01-S $_{x}$ EtherNet/IP network	Not compatible	Not compatible

For additional information on the 2094-BC $_{xx}$ -M $_{xx}$ -M (IAM) and 2094-BM $_{xx}$ -M (AM) modules, refer to the Kinetix 6200 and Kinetix 6500 Multi-axis Servo Drives User Manual, publication [2094-UM002](#).

Kinetix 6000M Integrated Drive-Motor System Compatibility

Bulletin 2094 power rails with Kinetix 6000 (series B and C) or Kinetix 6200 drives are compatible with Kinetix 6000M integrated drive-motor (IDM) systems. The IDM power interface module (IPIM) mounts to the power rail and connects to as many as 16 IDM units.

Table 7 - IPIM Module Compatibility

IAM Module	Control Module	2094-SEPM-B24-S IDM Power Interface Module (IPIM)
2094-BC $_{xx}$ -M $_{xx}$ -S (series B and C)	N/A	Fully compatible
2094-BC $_{xx}$ -M $_{xx}$ -M (IAM power module)	2094-SE02F-M00-S $_{x}$ sercos interface	
		2094-EN02D-M01-S $_{x}$ EtherNet/IP network

For more information on Kinetix 6000M integrated drive-motor system installation, refer to the Kinetix 6000M Integrated Drive-Motor System User Manual, publication [2094-UM003](#).

Agency Compliance

If this product is installed within the European Union and has the CE mark, the following regulations apply.



ATTENTION: Meeting CE requires a grounded system, and the method of grounding the AC line filter and drive must match. Failure to do this renders the filter ineffective and can cause damage to the filter.

For grounding examples, refer to Grounded Power Configurations on [page 83](#).

For more information on electrical noise reduction, refer to the System Design for Control of Electrical Noise Reference Manual, publication [GMC-RM001](#).

CE Requirements (system without LIM module)

To meet CE requirements when your Kinetix 6000 system does not include the LIM module, these requirements apply.

- Install 2090-XXLF-xxxx AC line filters for three-phase input power and single-phase control power as close to the IAM module as possible.
- Use 2090 series motor power cables or use connector kits and terminate the cable shields to the chassis clamp provided.
- Combined motor power cable lengths for all Kinetix 6000 axes and hybrid cable lengths for all IDM units on the same DC bus must not exceed 240 m (787 ft) with 400V-class systems or 160 m (525 ft) with 200V-class systems. Drive-to-motor power cables must not exceed 90 m (295.5 ft).
- Use 2090 series motor feedback cables or use connector kits and properly terminate the feedback cable shield. Drive-to-motor feedback cables must not exceed 90 m (295.5 ft).
- Install the Kinetix 6000 system inside an enclosure. Run input power wiring in conduit (grounded to the enclosure) outside of the enclosure. Separate signal and power cables.

Refer to [Appendix A](#) on [page 185](#) for interconnect diagrams, including input power wiring and drive/motor interconnect diagrams.

CE Requirements (system with LIM module)

To meet CE requirements when your Kinetix 6000 system includes the LIM module, follow all the requirements as stated in [CE Requirements \(system without LIM module\)](#) and these additional requirements as they apply to the AC line filter.

- Install the LIM module (catalog numbers 2094-AL09 or 2094-BL02) as close to the IAM module as possible.
- Install the LIM module (catalog numbers 2094-ALxxS, 2094-BLxxS, or 2094-XL75S-Cx) with line filter (catalog number 2090-XXLF-xxxx) as close to the IAM module as possible.

When the LIM module (catalog numbers 2094-ALxxS, 2094-BLxxS, or 2094-XL75S-Cx) supports two IAM modules, each IAM module requires an AC line filter installed as close to the IAM module as possible.

Planning the Kinetix 6000 Drive System Installation

This chapter describes system installation guidelines used in preparation for mounting your Kinetix 6000 drive components.

Topic	Page
System Design Guidelines	26
Electrical Noise Reduction	34



ATTENTION: Plan the installation of your system so that you can perform all cutting, drilling, tapping, and welding with the system removed from the enclosure. Because the system is of the open type construction, be careful to keep any metal debris from falling into it. Metal debris or other foreign matter can become lodged in the circuitry, which can result in damage to components.

System Design Guidelines

Use the information in this section when designing your enclosure and planning to mount your system components on the panel.

For on-line product selection and system configuration tools, including AutoCAD (DXF) drawings of the product, refer to <http://www.rockwellautomation.com/en/e-tools>.

System Mounting Requirements

- To comply with UL and CE requirements, the Kinetix 6000 drive system must be enclosed in a grounded conductive enclosure offering protection as defined in standard EN 60529 (IEC 529) to IP54 such that they are not accessible to an operator or unskilled person. A NEMA 4X enclosure exceeds these requirements providing protection to IP66.
- The panel you install inside the enclosure for mounting your system components must be on a flat, rigid, vertical surface that won't be subjected to shock, vibration, moisture, oil mist, dust, or corrosive vapors.
- Size the drive enclosure so as not to exceed the maximum ambient temperature rating. Consider heat dissipation specifications for all drive components.
- Combined motor power cable lengths for all axes and hybrid cable lengths for all IDM units on the same DC bus must not exceed 240 m (787 ft) with 400V-class systems or 160 m (525 ft) with 200V-class systems. Drive-to-motor power cables must not exceed 90 m (295.5 ft).

IMPORTANT System performance was tested at these cable length specifications. These limitations also apply when meeting CE requirements.

- Segregate input power wiring and motor power cables from control wiring and motor feedback cables. Use shielded cable for power wiring and provide a grounded 360° clamp termination.
- Use high-frequency (HF) bonding techniques to connect the modules, enclosure, machine frame, and motor housing, and to provide a low-impedance return path for high-frequency (HF) energy and reduce electrical noise.

Refer to the System Design for Control of Electrical Noise Reference Manual, publication [GMC-RM001](#), to better understand the concept of electrical noise reduction.

Transformer Selection

The IAM module does not require an isolation transformer for three-phase input power. However, a transformer can be required to match the voltage requirements of the controller to the available service.

To size a transformer for the main AC power inputs, refer to the Kinetix 6000 power specifications in the Kinetix Servo Drives Technical Data, publication [GMC-TD003](#).

IMPORTANT If using an autotransformer, make sure that the phase to neutral/ground voltages do not exceed the input voltage ratings of the drive.

IMPORTANT Use a form factor of 1.5 for three-phase power (where form factor is used to compensate for transformer, drive module, and motor losses, and to account for utilization in the intermittent operating area of the torque speed curve).

For example, to size a transformer to the voltage requirements of a 2094-BC01-M01-S integrated axis module:
 2094-BC01-M01-S = 6 kW continuous x 1.5 = 9.0 KVA transformer

AC Line Filter Selection

These AC line filters are available for your servo drive input power.

Table 8 - Kinetix 6000 (three-phase) AC Line Filter Selection

Drive Cat. No.	Voltage	Current A @ 50 °C (122 °F)	Weight, approx kg (lb)	AC Line Filter Cat. No.
2094-AC05-MP5-S	500V AC 50/60 Hz	30	2.7 (5.9)	2090-XXLF-X330B
2094-AC05-M01-S				
2094-AC09-M02-S				
2094-AC16-M03-S				
2094-AC32-M05-S		75	5.2 (11.4)	2090-XXLF-375
2094-AC32-M05-S		100	9.5 (20.9)	2090-XXLF-3100
2094-BC01-MP5-S	500V AC 50/60 Hz	30	2.7 (5.9)	2090-XXLF-X330B
2094-BC01-M01-S				
2094-BC02-M02-S				
2094-BC04-M03-S				
2094-BC07-M05-S				
2094-BC07-M05-S		75	5.2 (11.4)	2090-XXLF-375B
2094-BC07-M05-S		100	9.5 (20.9)	2090-XXLF-3100

Refer to the Kinetix Motion Accessories Specifications Technical Data, publication [GMC-TD004](#), for additional AC line filter specifications.

Circuit Breaker/Fuse Options

The 2094-*xCxx-Mxx-S* and 2094-*xMxx-S* drive modules and the Kinetix 6000M integrated drive-motor system (2094-SEPM-B24-S IPIM module and MDF-SBxxxxx IDM units) use internal solid-state motor short-circuit protection and, when protected by suitable branch circuit protection, are rated for use on a circuit capable of delivering up to 200,000 A. Fuses or circuit breakers, with adequate withstand and interrupt ratings, as defined in NEC or applicable local codes, are permitted.

The 2094-AL09 and 2094-BL02 LIM modules contain supplementary protection devices and, when protected by suitable branch circuit protection, are rated for use on a circuit capable of delivering up to 5000 A. When these modules are used, protection on the line side of the LIM module is required. Fuses must be class J or CC only.

The 2094-ALxxS, 2094-BLxxS, and 2094-XL75S-Cx LIM modules contain branch circuit rated devices suitable for use on a circuit capable of delivering up to 65,000 A (400V-class) or 100,000 A (200V-class).

Refer to the Line Interface Module Installation Instructions, publication [2094-IN005](#), for power specifications and more information on using the LIM module.

The Bulletin 140M and 140U products are another acceptable means of protection. As with fuses and circuit breakers, you must make sure that the selected components are properly coordinated and meet applicable codes including any requirements for branch circuit protection. When applying the 140M/140U product, evaluation of the short circuit available current is critical and must be kept below the short circuit current rating of the 140M/140U product.

In most cases, class CC, J, L, and R fuses selected to match the drive input current rating meets the NEC requirements or applicable local codes, and provide the full drive capabilities. Use dual element, time delay (slow-acting) fuses to avoid nuisance trips during the inrush current of power initialization.

Circuit Breaker and Fuse Specifications

While circuit breakers offer some convenience, there are limitations for their use. Circuit breakers do not handle high current inrush as well as fuses.

Make sure the selected components are properly coordinated and meet acceptable codes including any requirements for branch circuit protection. Evaluation of the short-circuit available current is critical and must be kept below the short-circuit current rating of the circuit breaker.

The following fuse examples and Allen-Bradley® circuit breakers are recommended for use with 2094-xCxx-Mxx-S IAM modules when the Line Interface Module (LIM) is not used.

IMPORTANT LIM Modules (catalog numbers 2094-ALxxS, 2094-BLxxS, and 2094-XL75S-Cx) provide branch circuit protection to the IAM module. Follow all applicable NEC and local codes.

Table 9 - Kinetix 6000 Circuit Breaker and Fuse Selection

IAM Module Cat. No.	V AC Input Power			Control Input Power		DC Common Bus Fuse			
	Bussmann Fuse	Allen-Bradley Circuit Breaker		Bussmann Fuse ⁽¹⁾	Allen-Bradley ⁽²⁾ Circuit Breaker	Bussmann Fuse	Ferraz Shawmut Fuse		
		Disconnect	Magnetic Contactor						
2094-AC05-MP5-S	KTK-R-20 (20 A)	1492-SP3D300	140M-F8E-C16	FNQ-R-10 (10 A)	1492-SP2D060	N/A	A50P20-1		
2094-AC05-M01-S						FWH-35B	A50P35-4		
2094-AC09-M02-S	KTK-R-30 (30 A)	1492-SP3D400	140M-F8E-C20		1492-SP2D200	FWH-60B	A50P60-4		
2094-AC16-M03-S	LPJ-45SP (45 A)	N/A	140U-H6C3-C50			FWH-125B	A50P125-4		
2094-AC32-M05-S	LPJ-80SP (80 A)	N/A	140U-H6C3-C90		FNQ-R-10 (10 A) or FNQ-R-7.5 (7.5 A)	1492-SP2D060 or 1492-SP1D150	FWJ-20A14F	DCT20-2	
2094-BC01-MP5-S	KTK-R-20 (20 A)	1492-SP3D300	140M-F8E-C32	FWJ-40A			A70QS40-4		
2094-BC01-M01-S				N/A			140U-H6C3-C50	FWJ-70A	A70QS70-4
2094-BC02-M02-S	KTK-R-30 (30 A)	1492-SP3D400	140M-F8E-C45					FWJ-125A	A70QS125-4
2094-BC04-M03-S								LPJ-45SP (45 A)	140U-H6C3-C90
2094-BC07-M05-S	LPJ-80SP (80 A)								

(1) Use FNQ-R-7.5 fuse for higher single-cycle inrush current capability. This is recommended when the continuous control power current exceeds 3.0 A.
 (2) Use 1492-SP1D150 circuit breaker for higher single-cycle inrush current capability. This is recommended when the continuous control power current exceeds 3.0 A.

Refer to the Kinetix Servo Drives Technical Data, publication [GMC-TD003](#), for additional power specifications for your IAM module.

Enclosure Selection

This example is provided to assist you in sizing an enclosure for your Bulletin 2094 drive system. The example system consists of these components:

- 6-axis Bulletin 2094 servo drive system
- Line Interface Module (LIM)
- ControlLogix chassis and modules (controller)

Size the Bulletin 2094 servo drive and LIM module and use the results to predict the amount of heat dissipated into the enclosure. You also need heat dissipation data from other equipment inside the enclosure (such as the ControlLogix controller). Once the total amount of heat dissipation (in watts) is known, you can calculate the minimum enclosure size.

Table 10 - Bulletin 2094 System Heat Dissipation Example

Enclosure Component	Description	Loading ⁽¹⁾	Heat Dissipation ⁽¹⁾ watts	
2094-BC02-M02-x	Integrated axis module (IAM), 400/460V	15 kW (converter section)	20%	44
		15 A (inverter section)	40%	72
2094-BM02-x	Axis module (AM), 400/460V, 15 A	60%	93	
2094-BM02-x	Axis module (AM), 400/460V, 15 A	60%	93	
2094-BM01-x	Axis module (AM), 400/460V, 9 A	40%	73	
2094-BM01-x	Axis module (AM), 400/460V, 9 A	40%	73	
2094-BM01-x	Axis module (AM), 400/460V, 9 A	20%	57	
2094-BL25S	Line interface module (LIM), 400/460V, 25 A; 24V DC 20 A	100%	43	
2094-PRS6	Power rail, 460V, 6 axis	N/A	0	
2090-XB33-32	Resistive brake module (RBM), 33 A, 32 Ω	N/A	30	
Total Kinetix 6000 system wattage			578	

(1) To determine heat dissipation specifications for your drive system components, refer to [Table 12](#) on [page 32](#).

Table 11 - ControlLogix System Heat Dissipation Example

Enclosure Component	Description	Backplane Power Load ⁽¹⁾ watts	Heat Dissipation ⁽¹⁾ watts
1756-M08SE	8-axis sercos interface module	3.2	0
1756-L5563	L63 ControlLogix processor	4.5	0
1756-IB16D	16 -point input module	0.84	5.8
1756-OB16D	16 -point output module	4.64	3.3
1756-ENxTx	EtherNet/IP communication module	4.0	0
Backplane total		17.18 ⁽²⁾	N/A
1756-PB72	24V DC ControlLogix power supply	N/A	25 ⁽²⁾
1756-A7	7-slot mounting chassis	N/A	N/A
Total ControlLogix system wattage			34.1

- (1) For ControlLogix module specifications, refer to the ControlLogix Selection Guide, publication [1756-SG001](#).
- (2) Real power heat dissipation is determined by applying the backplane power load (17.18W) to the graph below.

Figure 6 - ControlLogix Real Power

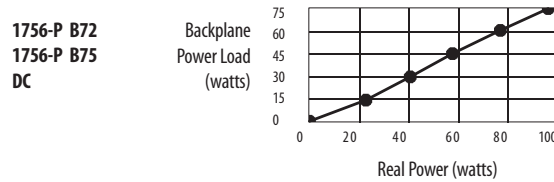

For backplane power loading requirements of other ControlLogix power supplies, refer to the ControlLogix Selection Guide, publication [1756-SG001](#).

In this example, the amount of power dissipated inside the cabinet is the sum of the Bulletin 2094 system value (578 W) and the ControlLogix system value (34 W) for a total of 612 W.

With no active method of heat dissipation (such as fans or air conditioning) either of these approximate equations can be used.

Metric	Standard English
$A = \frac{0.38Q}{1.8T - 1.1}$	$A = \frac{4.08Q}{T - 1.1}$
Where T is temperature difference between inside air and outside ambient (°C), Q is heat generated in enclosure (Watts), and A is enclosure surface area (m ²). The exterior surface of all six sides of an enclosure is calculated as	Where T is temperature difference between inside air and outside ambient (°F), Q is heat generated in enclosure (Watts), and A is enclosure surface area (ft ²). The exterior surface of all six sides of an enclosure is calculated as
$A = 2dw + 2dh + 2wh$	$A = (2dw + 2dh + 2wh) / 144$
Where d (depth), w (width), and h (height) are in meters.	Where d (depth), w (width), and h (height) are in inches.

Total system watts dissipated (Q) was calculated at 612 W. The maximum ambient rating of the Bulletin 2094 system is 50 °C (122 °F) and if the maximum environmental temperature is 30 °C (86 °F), then T=20 in the equation below.

$$A = \frac{0.38 (612)}{1.8 (20) - 1.1} = 6.66 \text{ m}^2$$

In this example, the enclosure must have an exterior surface of 6.66 m². If any portion of the enclosure is not able to transfer heat, do not include that portion in the calculation.

Because the minimum cabinet depth to house the 460V drive (selected for this example) is 302 mm (11.9 in.), then the cabinet needs to be approximately 2500 mm (high) x 950 mm (wide) x 302 mm (deep).

$$2 \times (0.3 \times 0.95) + 2 \times (0.3 \times 2.5) + 2 \times (0.95 \times 2.5) = 6.82 \text{ m}^2$$

Because this cabinet size is considerably larger than what is necessary to house the system components, consider some means of cooling in a smaller cabinet to be more efficient. Contact your cabinet manufacturer for options available to cool your cabinet.

Table 12 - Power Dissipation Specifications

Bulletin 2094 Drive Modules ⁽¹⁾	Usage as % of Rated Power Output (watts)				
	20%	40%	60%	80%	100%
IAM (converter) module ⁽²⁾					
2094-AC05-MP5-S	8	11	15	19	24
2094-AC05-M01-S	9	12	16	20	25
2094-AC09-M02-S	14	20	28	36	46
2094-AC16-M03-S	19	30	43	58	74
2094-AC32-M05-S	41	68	100	136	176
2094-BC01-MP5-S	18	21	25	29	34
2094-BC01-M01-S					33
2094-BC02-M02-S	36	44	54	64	75
2094-BC04-M03-S	50	67	87	110	135
2094-BC07-M05-SS	71	101	137	179	226
IAM (inverter) module or AM module ⁽²⁾					
2094-AC05-MP5-S or 2094-AMP5-S	28	32	37	41	46
2094-AC05-M01-S or 2094-AM01-S	31	38	46	54	62
2094-AC09-M02-S or 2094-AM02-S	34	45	57	70	84
2094-AC16-M03-S or 2094-AM03-S	48	68	91	116	144
2094-AC32-M05-S or 2094-AM05-S	104	156	212	274	342
2094-BC01-MP5-S or 2094-BMP5-S	46	54	61	69	77
2094-BC01-M01-S or 2094-BM01-S	57	73	90	108	126
2094-BC02-M02-S or 2094-BM02-S	53	72	93	116	142
2094-BC04-M03-S or 2094-BM03-S	94	130	169	211	255
2094-BC07-M05-S or 2094-BM05-S	121	183	252	326	407
Shunt module - 2094-BSP2	68	121	174	227	280
IPIM module - 2094-SEPM-B24-S	To calculate power dissipation for IPIM modules on your 2094 power rail, refer to the Kinetix 6000M Integrated Drive-Motor User Manual, publication 2094-UM003 .				

(1) Power dissipation for the Bulletin 2094 control modules, catalog numbers 2094-SE02F-M00-Sx and 2094-EN02D-M01-Sx, is included in the IAM and AM power module specifications.

(2) Internal shunt power is not included in the calculations and must be added based on utilization.

Minimum Clearance Requirements

This section provides information to assist you in sizing your cabinet and positioning your Bulletin 2094 system components.

IMPORTANT Mount the module in an upright position. Do not mount the module on its side.

[Figure 7](#) illustrates minimum clearance requirements for proper airflow and installation:

- Additional clearance is required for the cables and wires connected to the top and front of the drive.
- Additional clearance left and right of the power rail is required when the drive is mounted adjacent to noise sensitive equipment or clean wireways.

Figure 7 - Minimum Clearance Requirements

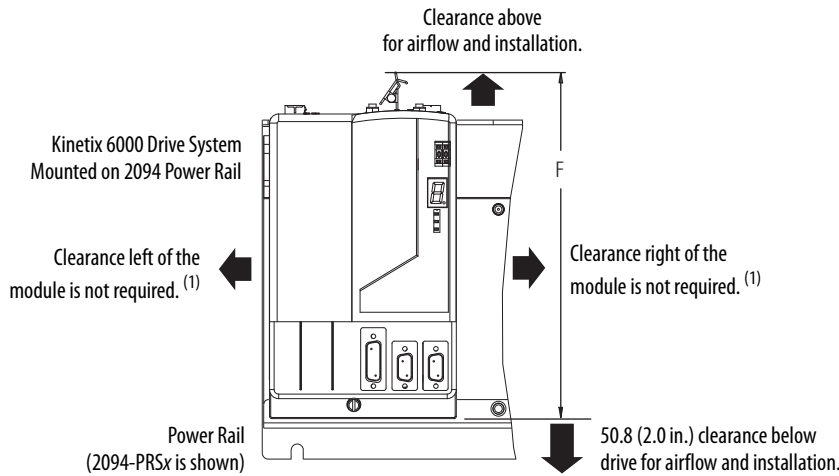

Refer to Power Dissipation Specifications on [page 32](#), and Kinetix Servo Drives Technical Data, publication [GMC-TD003](#), for Kinetix 6000 drive dimensions.

(1) The power rail (slim), catalog number 2094-PRx, extends left and right of the first and last module 5.0 mm (0.20 in.). The Bulletin 2094-PRx power rail extends approximately 25.4 mm (1.0 in.) left of the IAM module and right of the last module mounted on the rail.

Drive Cat. No.	Series	F
2094-AC05-Mxx-x 2094-AC09-M02-x	A and C	237 mm (9.3) in.
2094-AMP5-x, 2094-AM01-x, 2094-AM02-x		
2094-AC16-M03-x 2094-AC32-M05-x	A and C	420 mm (16.5) in.
2094-AM03-x, 2094-AM05-x		
2094-BC01-Mxx-x 2094-BC02-M02-x	A, B, and C	287 mm (11.3) in.
2094-BMP5-x, 2094-BM01-x, 2094-BM02-x		
2094-SEPM-B24-S 2094-BSP2		
2094-BC04-M03-x 2094-BM03-x	A, B, and C	374 mm (14.7) in.
2094-BC07-M05-x 2094-BM05-x	B and C	
2094-BC07-M05-x 2094-BM05-x	A and C	436 mm (17.2) in.

Table 13 - Minimum Cabinet Depth

Drive Cat. No.	Cabinet Depth, min ⁽¹⁾	Drive Cat. No.	Cabinet Depth, min ⁽¹⁾
2094-AC05-Mxx-x, 2094-AC09-M02-x, 2094-AMP5-x, 2094-AM01-x, 2094-AM02-x	198 mm (7.8 in.)	2094-AC16-M03-x, 2094-AC32-M05-x, 2094-AM03-x, 2094-AM05-x	198 mm (7.8 in.)
2094-BC01-Mxx-x, 2094-BC02-M02-x, 2094-BMP5-x, 2094-BM01-x, 2094-BM02-x	272 mm (10.7 in.)	2094-BC04-M03-x, 2094-BC07-M05-x, 2094-BM03-x, 2094-BM05-x	272 mm (10.7 in.)
2094-BSP2	272 mm (10.7 in.)	2094-SEPM-B24-S	263 mm (10.3 in.)

(1) Minimum cabinet depth is based on the use of 2090-K6CK-xxx low-profile connector kits. Other means of making feedback connections can require additional clearance.

Electrical Noise Reduction

This section outlines best practices that minimize the possibility of noise-related failures as they apply specifically to Kinetix 6000 system installations. For more information on the concept of high-frequency (HF) bonding, the ground plane principle, and electrical noise reduction, refer to the System Design for Control of Electrical Noise Reference Manual, publication [GMC-RM001](#).

Bonding Modules

Bonding is the practice of connecting metal chassis, assemblies, frames, shields, and enclosures to reduce the effects of electromagnetic interference (EMI).

Unless specified, most paints are not conductive and act as insulators. To achieve a good bond between power rail and the subpanel, surfaces need to be paint-free or plated. Bonding metal surfaces creates a low-impedance return path for high-frequency energy.

IMPORTANT To improve the bond between the power rail and subpanel, construct your subpanel out of zinc plated (paint-free) steel.

Improper bonding of metal surfaces blocks the direct return path and allows high-frequency energy to travel elsewhere in the cabinet. Excessive high-frequency energy can effect the operation of other microprocessor controlled equipment.

These illustrations show details of recommended bonding practices for painted panels, enclosures, and mounting brackets.

Figure 8 - Recommended Bonding Practices for Painted Panels

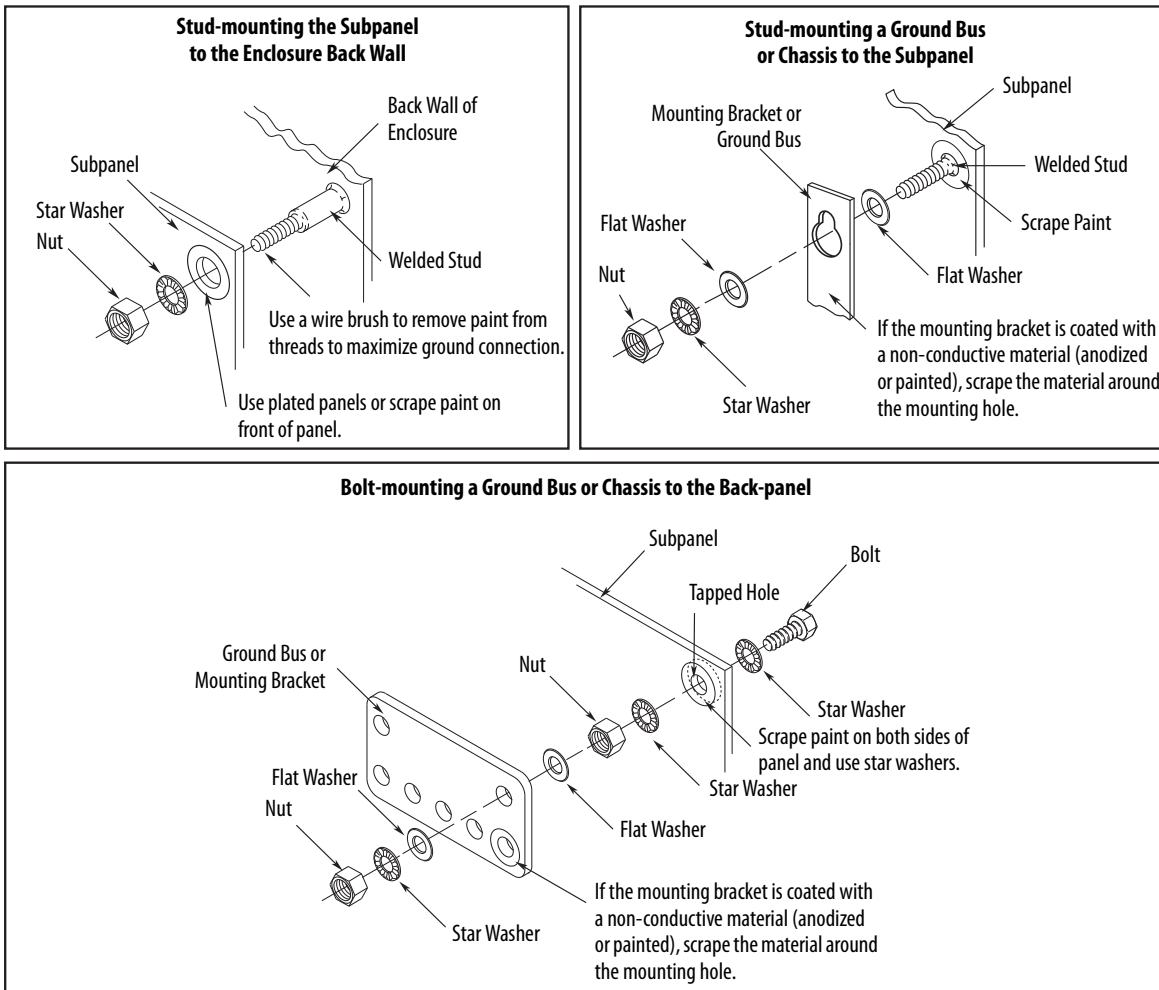

Bonding Multiple Subpanels

Bonding multiple subpanels creates a common low impedance exit path for the high frequency energy inside the cabinet. If subpanels are not bonded together, and do not share a common low impedance path, the difference in impedance can affect networks and other devices that span multiple panels:

- Bond the top and bottom of each subpanel to the cabinet by using 25.4 mm (1.0 in.) by 6.35 mm (0.25 in.) wire braid. As a rule, the wider and shorter the braid is, the better the bond.
- Scrape the paint from around each fastener to maximize metal-to-metal contact.

Figure 9 - Multiple Subpanels and Cabinet Recommendations

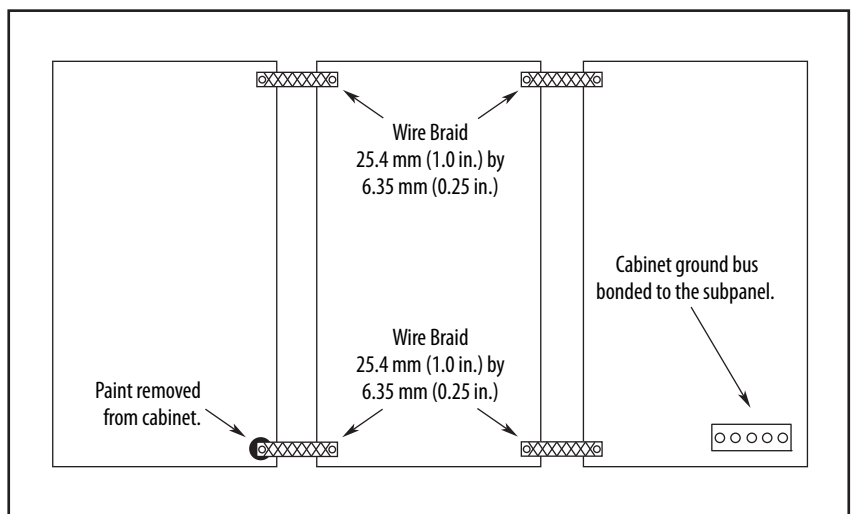

Establishing Noise Zones

Observe these guidelines when the 2094-ALxxS, 2094-BLxxS, or 2094-XL75S-Cx LIM module is used in the Bulletin 2094 system and mounted left of the IAM module with the AC (EMC) line filter mounted above the LIM module:

- The clean zone (C) is to the right and beneath the Bulletin 2094 system (gray wireway).
- The dirty zone (D) is to the left and above the Bulletin 2094 system, and above and below the LIM module (black wireway).
- The very dirty zone (VD) is from the filter output to IAM module. Shielded cable is required on the EMC filter (load side) and the braided shield attached to the clamp provided.
- The sercos fiber-optic cables are immune to electrical noise, but due to their delicate nature, route them in the clean zone.

Figure 10 - Noise Zones (LIM mounted left of IAM module)

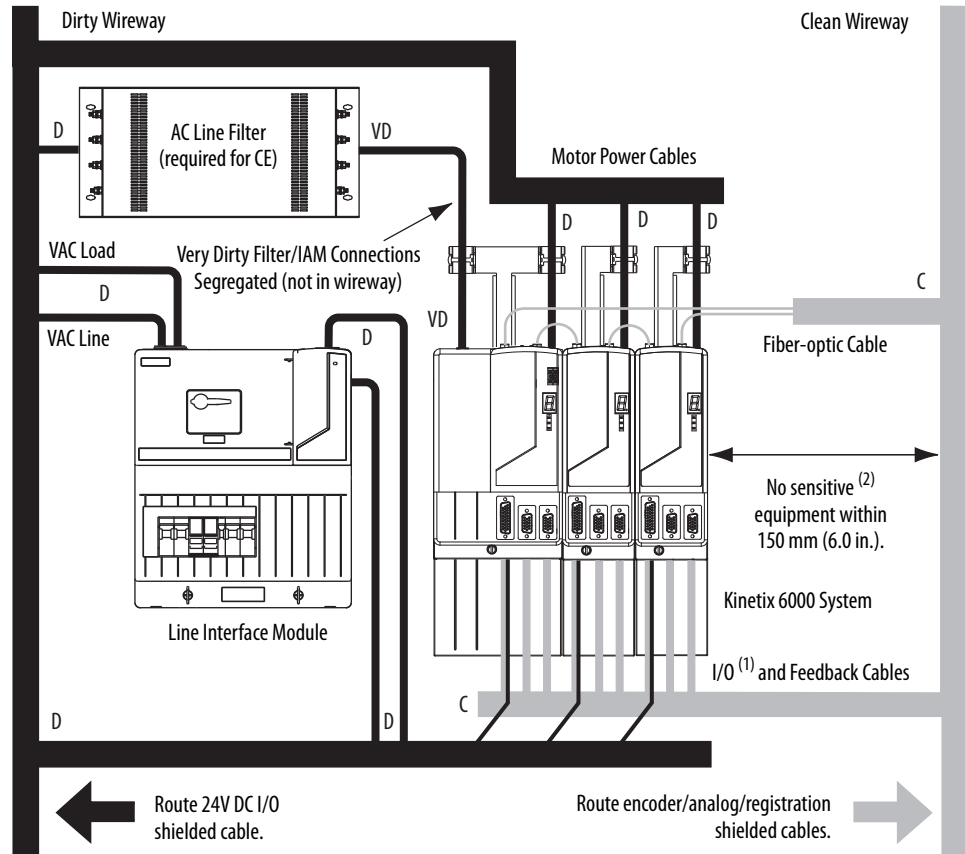

- (1) If drive system I/O cable contains (dirty) relay wires, route cable with LIM module I/O cable in dirty wireway.
- (2) When space does not permit the 150 mm (6.0 in.) segregation, use a grounded steel shield instead. For examples, refer to the System Design for Control of Electrical Noise Reference Manual, publication [GMC-RM001](#).

Observe these guidelines when the 2094-ALxxS, 2094-BLxxS, or 2094-XL75S-Cx LIM module is used in the Bulletin 2094 system and mounted right of the IAM module with the AC (EMC) line filter mounted behind the IAM module:

- The clean zone (C) is to the left and beneath the Bulletin 2094 system (gray wireway).
- The dirty zone (D) is to the right and above the Bulletin 2094 system, and above and below the LIM module (black wireway).
- The very dirty zone (VD) is from the filter output to IAM module. Shielded cable is required on the EMC filter (load side) and the braided shield attached to the clamp provided.
- The sercos fiber-optic cables are immune to electrical noise, but due to their delicate nature, route them in the clean zone.

Figure 11 - Noise Zones (LIM with EMC filter behind IAM module)

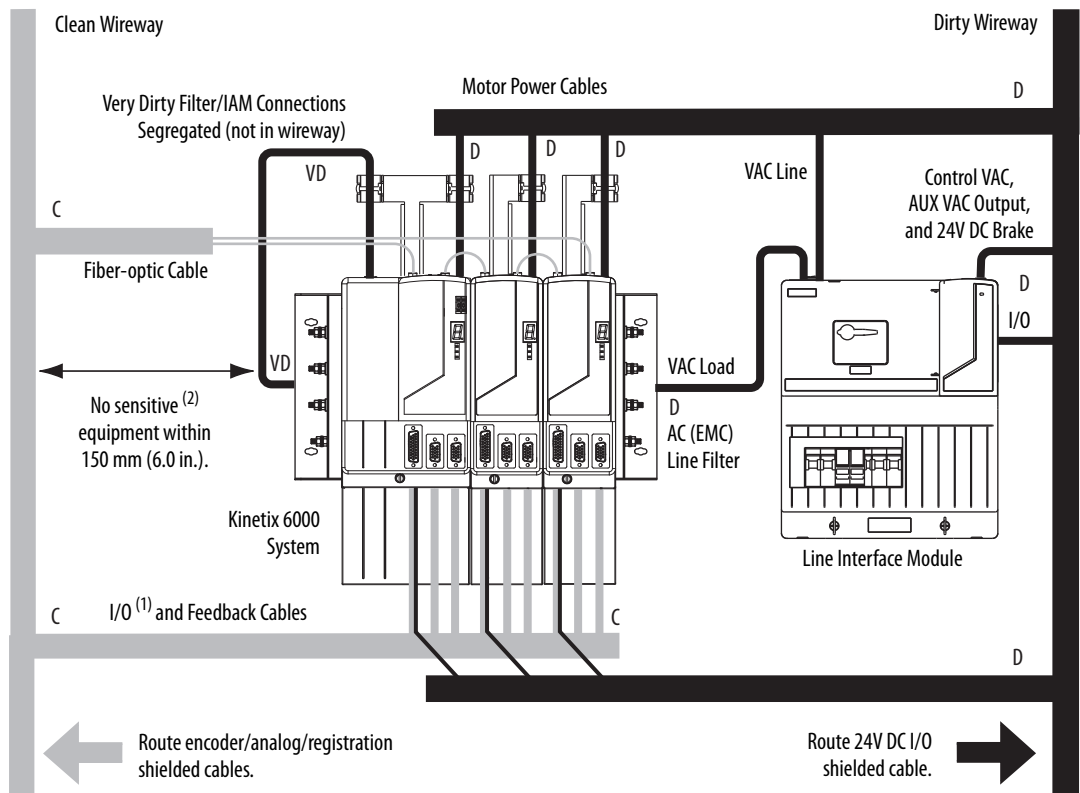

- (1) If drive system I/O cable contains (dirty) relay wires, route cable with LIM module I/O cable in dirty wireway.
- (2) When space does not permit the 150 mm (6.0 in.) segregation, use a grounded steel shield instead. For examples, refer to the System Design for Control of Electrical Noise Reference Manual, publication [GMC-RM001](#).

Observe these guidelines when the 2094-ALxxS, 2094-BLxxS, or 2094-XL75S-Cx LIM module is used in the Bulletin 2094 system and mounted right of the drive with the AC (EMC) line filter mounted behind the LIM module:

- The clean zone (C) is to the left and beneath the Bulletin 2094 system (gray wireway).
- The dirty zone (D) is to the right and above the Bulletin 2094 system, and above and below the LIM module (black wireway).
- The very dirty zone (VD) is from the filter output to drive. Shielded cable is required on the EMC filter (load side) and the braided shield attached to the clamp (when provided).
- The sercos fiber-optic cables are immune to electrical noise, but due to their delicate nature, route them in the clean zone.

Figure 12 - Noise Zones (EMC filter behind LIM module)

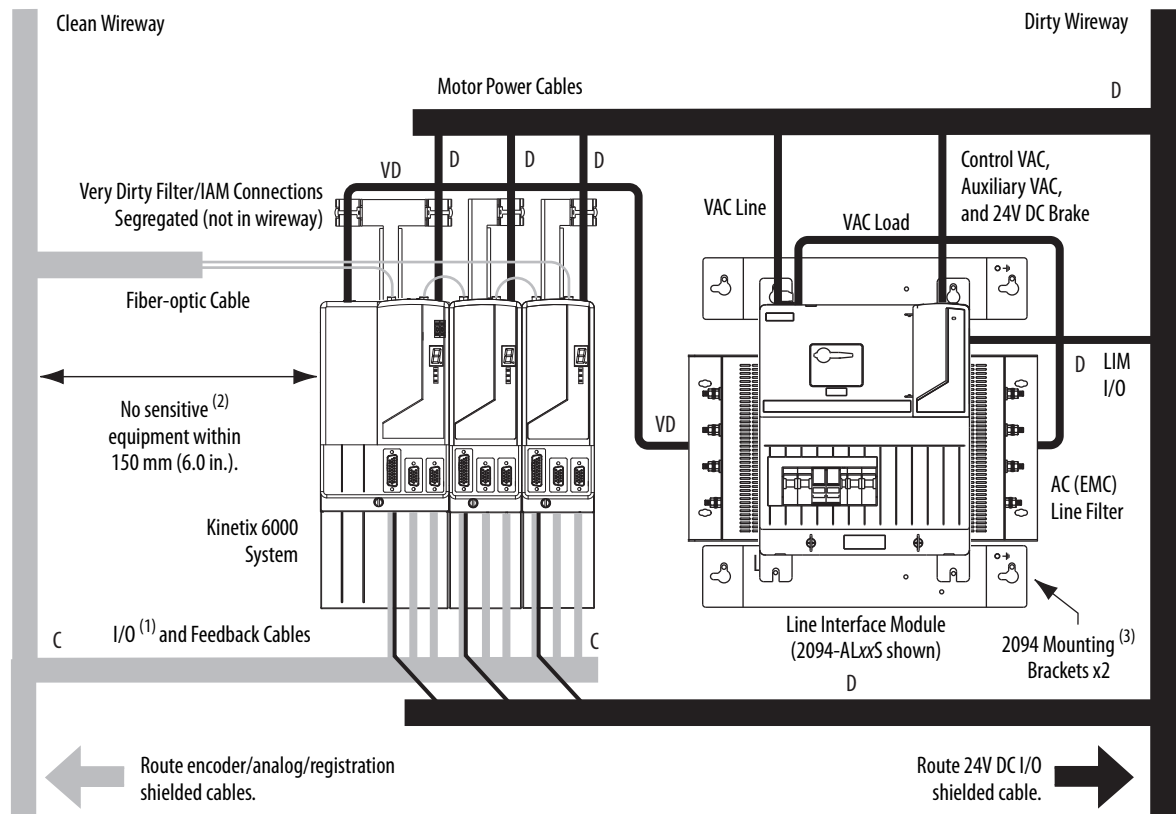

- (1) If drive system I/O cable contains (dirty) relay wires, route cable with LIM module I/O cable in dirty wireway.
- (2) When space does not permit the 150 mm (6.0 in.) segregation, use a grounded steel shield instead. For examples, refer to the System Design for Control of Electrical Noise Reference Manual, publication [GMC-RM001](#).
- (3) Only the 2094-ALxxS and 2094-XL75S-Cx LIM modules are compatible with the 2094 mounting brackets. The 2094-BLxxS, 2094-AL09, and 2094-BL02 LIM modules are not compatible.

Keep the DC common-bus cable (very dirty) segregated from all other cables (not in a wireway) when the 2094-ALxxS, 2094-BLxxS, or 2094-XL75S-Cx LIM module is used in a DC common-bus configuration and the follower IAM module is mounted below the leader IAM module.

Figure 13 - Noise Zones (DC common bus)

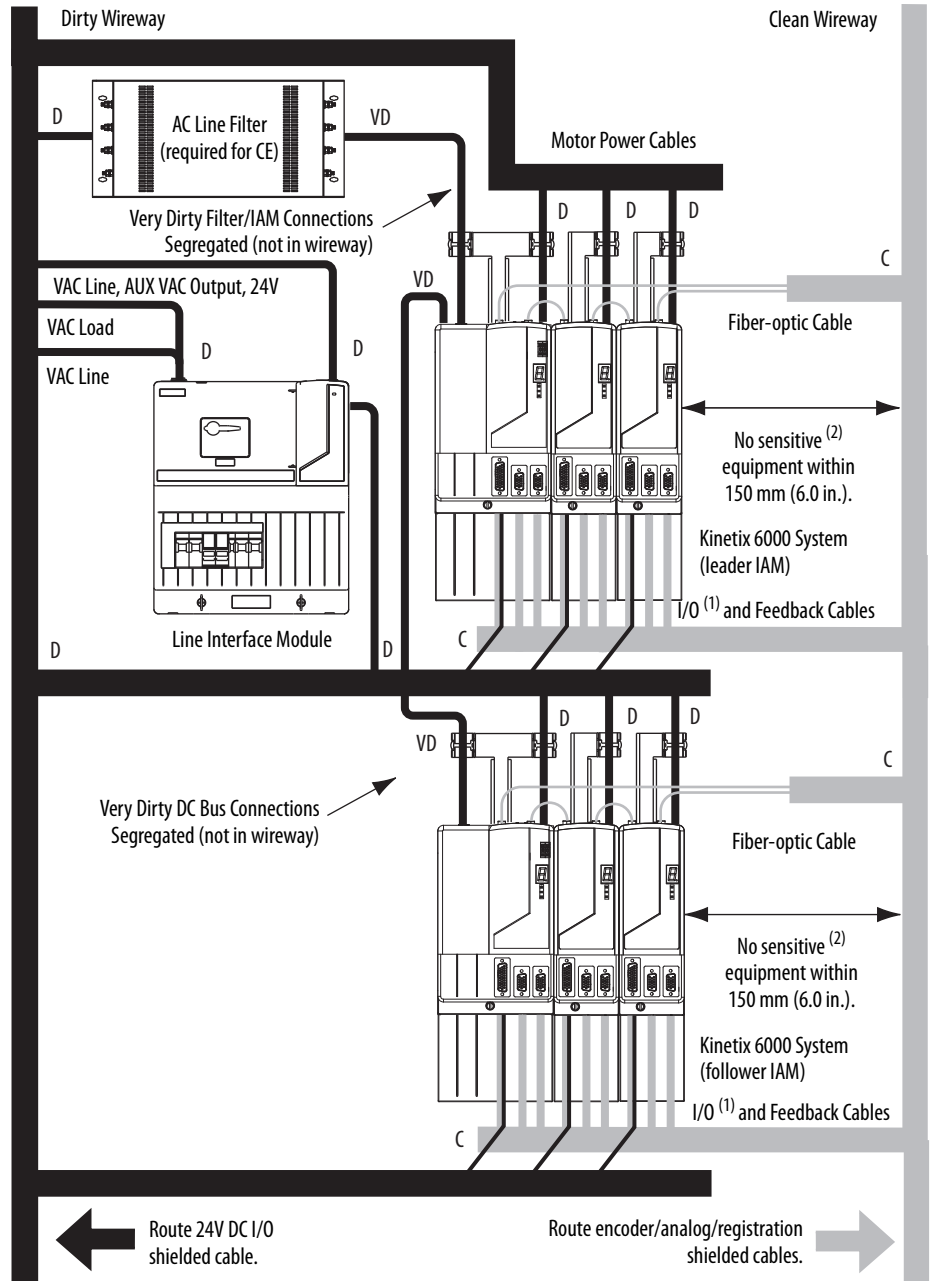

- (1) If drive system I/O cable contains (dirty) relay wires, route cable with LIM module I/O cable in dirty wireway.
- (2) When space does not permit the 150 mm (6.0 in.) segregation, use a grounded steel shield instead. For examples, refer to the System Design for Control of Electrical Noise Reference Manual, publication [GMC-RM001](#).

Observe these guidelines when the 2094-AL09 or 2094-BL02 LIM module is used in the Bulletin 2094 system and mounted left of the IAM module:

- The clean zone (C) is to the right and beneath the Bulletin 2094 system (gray wireway).
- The dirty zone (D) is to the left and above the Bulletin 2094 system, and above and below the LIM module (black wireway).
- The very dirty zone (VD) is limited to where the LIM module VAC output jumpers over to the IAM module. Shielded cable is required only if the very dirty cables enter a wireway.
- The sercos fiber-optic cables are immune to electrical noise, but due to their delicate nature, route them in the clean zone.

This layout is preferred due to the reduced size of the very dirty zone.

Figure 14 - Noise Zones (LIM mounted left of IAM module)

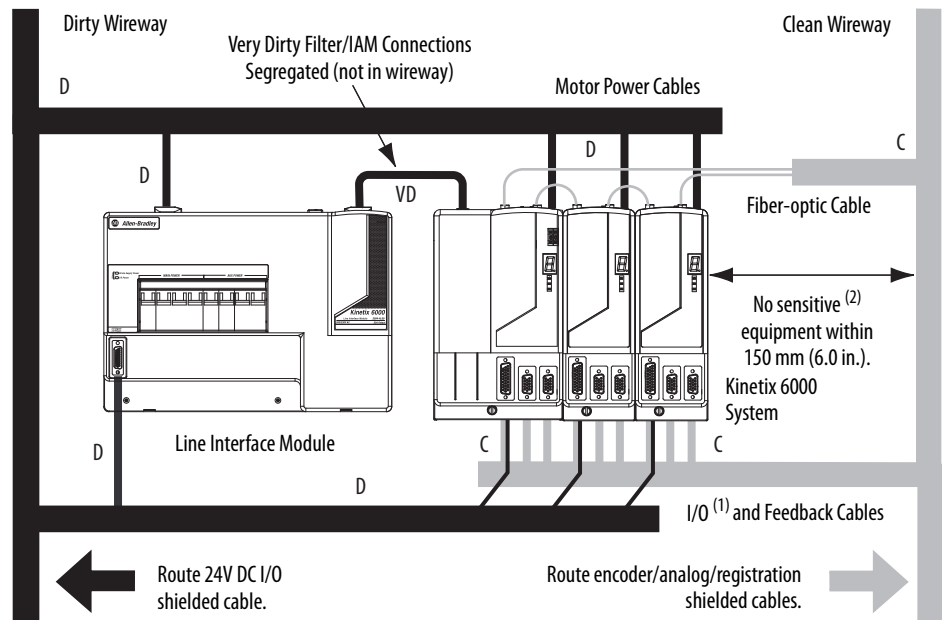

(1) If drive system I/O cable contains (dirty) relay wires, route cable with LIM module I/O cable in dirty wireway.

(2) When space does not permit the 150 mm (6.0 in.) segregation, use a grounded steel shield instead. For examples, refer to the System Design for Control of Electrical Noise Reference Manual, publication [GMC-RM001](#).

Observe these guidelines when the 2094-AL09 or 2094-BL02 LIM module is used in the Bulletin 2094 system and mounted above the IAM module:

- The clean zone (C) is to the right and beneath the Bulletin 2094 system (gray wireway).
- The dirty zone (D) is to the left and above the Bulletin 2094 system, and above and below the LIM module (black wireway).
- The LIM VAC output is very dirty (VD). Use shielded cable with a braid clamp attached at both ends of the cable to reduce the rating to dirty (D).
- The sercos fiber-optic cables are immune to electrical noise, but due to their delicate nature, route them in the clean zone.

Figure 15 - Noise Zones (LIM mounted above IAM module)

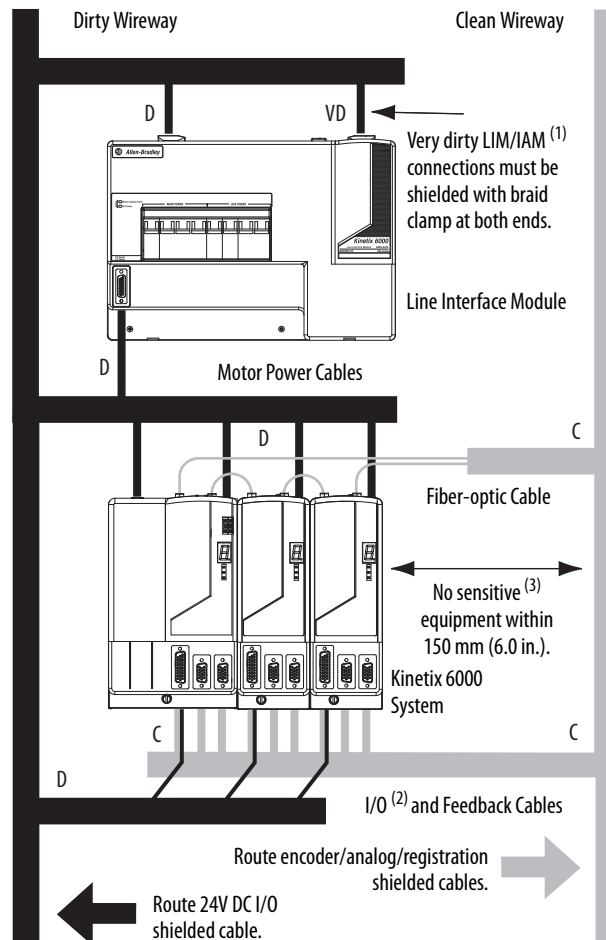

- (1) For examples of shield clamp attachment, refer to the System Design for Control of Electrical Noise Reference Manual, publication [GMC-RM001](#).
- (2) If drive system I/O cable contains (dirty) relay wires, route cable in dirty wireway.
- (3) When space does not permit the 150 mm (6.0 in.) segregation, use a grounded steel shield instead. For examples, refer to the System Design for Control of Electrical Noise Reference Manual, publication [GMC-RM001](#).

Observe these guidelines when your system includes the 2094-SEPM-B24-S IPIM module. In this example, a 2094-BL02 LIM module is used in the Bulletin 2094 system and mounted left of the IAM module:

- Establish clean (C) and dirty zones (D) similar to other Bulletin 2094 drive systems.
- The sercos fiber-optic cables are immune to electrical noise, but due to their delicate nature, route them in the clean zone.
- IPIM digital input wires are noise sensitive and belong with the fiber-optic cables in the clean zone.
- Ethernet cables are noise sensitive and belong in the clean zone, however, they are connected only when programming the IPIM module.
- IDM network cables, although noise sensitive by nature, are shielded and can be routed with the hybrid cables outside of the enclosure.
- The Bulletin 2090 hybrid cable is dirty and belongs in the dirty zone.

This layout is preferred due to the reduced size of the very dirty zone.

Figure 16 - Noise Zones (Bulletin 2094 power rail with IPIM module)

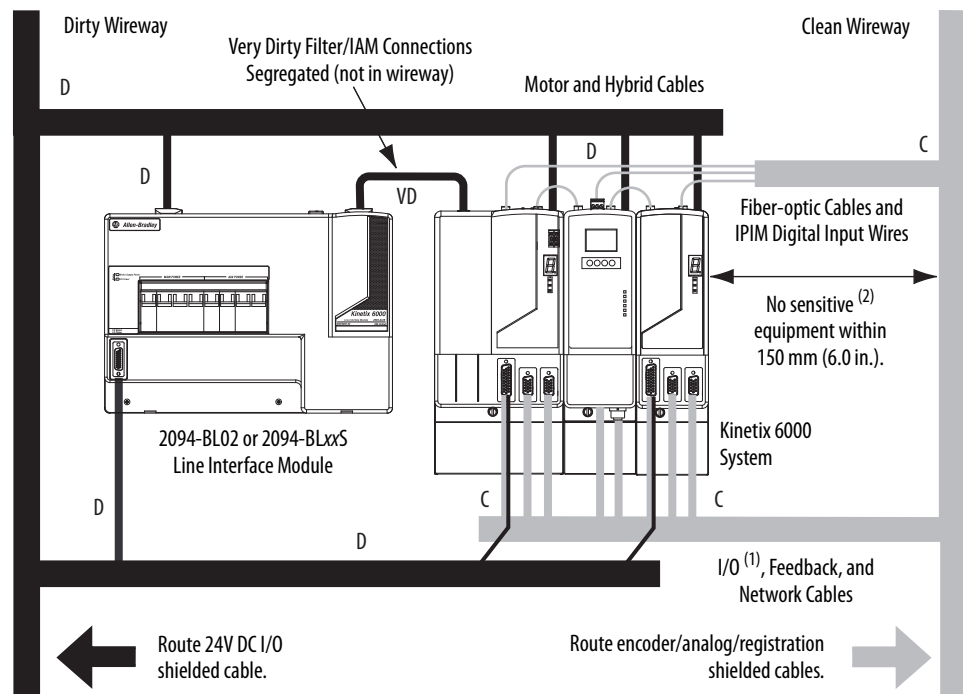

- (1) If drive system I/O cable contains (dirty) relay wires, route cable with LIM module I/O cable in dirty wireway.
- (2) When space does not permit the 150 mm (6.0 in.) segregation, use a grounded steel shield instead. For examples, refer to the System Design for Control of Electrical Noise Reference Manual, publication [GMC-RM001](#).

Observe these guidelines when individual input power components are used in the Bulletin 2094 system and the Bulletin 2094 LIM module is not used:

- The clean zone (C) is beneath the Bulletin 2094 system and includes the I/O wiring, feedback cable, and DC filter (gray wireway).
- The dirty zone (D) is above the Bulletin 2094 system (black wireway) and includes the circuit breakers, transformer, 24V DC power supply, contactors, AC line filter, and motor power cables.
- The very dirty zone (VD) is limited to where the AC line (EMC) filter VAC output jumpers over to the IAM module. Shielded cable is required only if the very dirty cables enter a wireway.
- The sercos fiber-optic cables are immune to electrical noise, but due to their delicate nature, route them in the clean zone.

Figure 17 - Noise Zones (without LIM module)

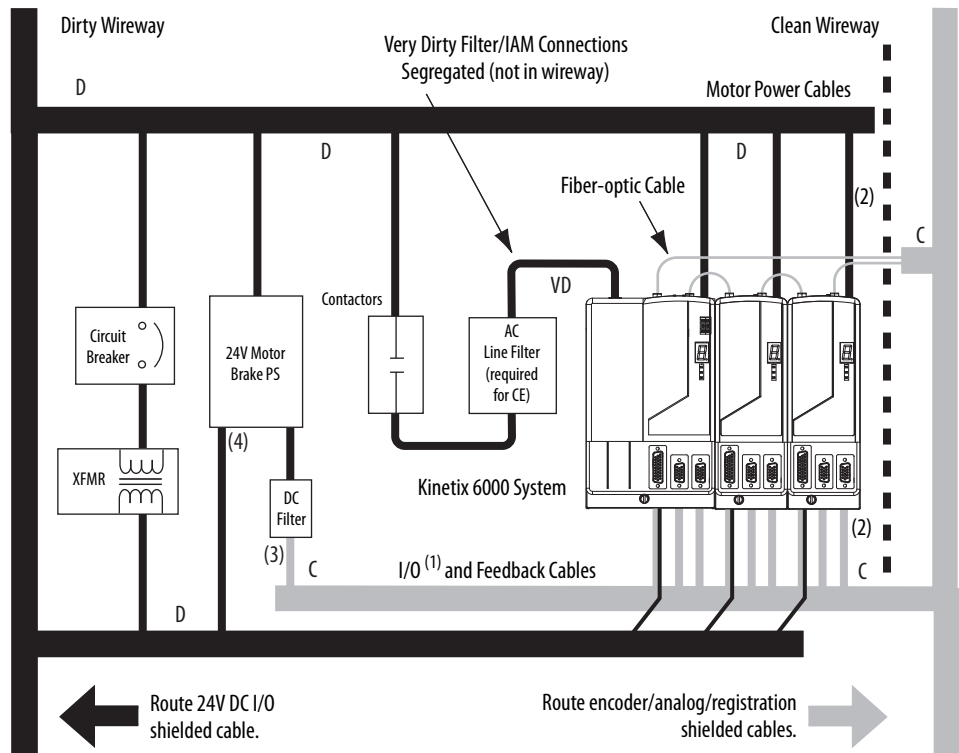

- (1) If drive system I/O cable contains (dirty) relay wires, route cable in dirty wireway.
- (2) When space to the right of the IAM does not permit 150 mm (6.0 in.) segregation, use a grounded steel shield instead. For examples, refer to the System Design for Control of Electrical Noise Reference Manual, publication [GMC-RM001](#).
- (3) This is a clean 24V DC available for any device that requires it. The 24V enters the clean wireway and exits to the right.
- (4) This is a dirty 24V DC available for motor brakes and contactors. The 24V enters the dirty wireway and exits to the left.

Observe these guidelines when installing your Logix5000 sercos interface module:

- The clean zone (C) is beneath the less noisy modules (I/O, analog, encoder, registration, an so forth (gray wireway).
- The dirty zone (D) is above and below the power supply and noisy modules (black wireway).
- The sercos fiber-optic cables are immune to electrical noise, but due to their delicate nature, route them in the clean zone.

Figure 18 - Noise Zones (ControlLogix chassis)

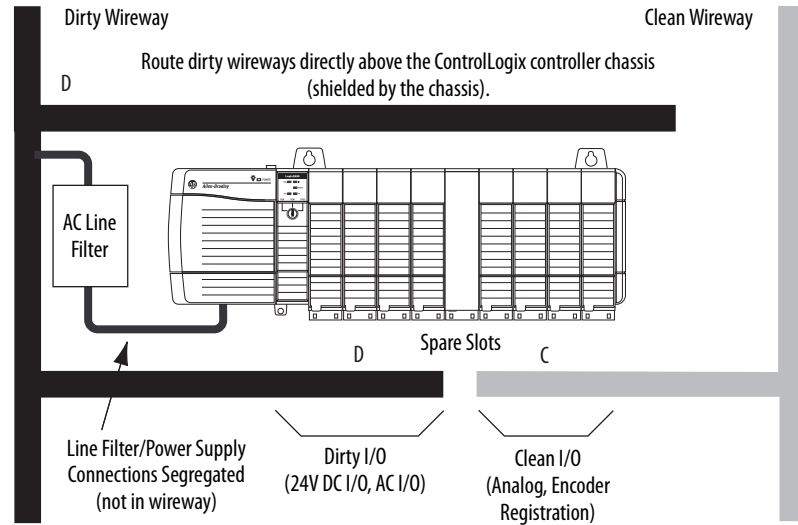

Cable Categories for Kinetix 6000 Systems

These tables indicate the zoning requirements of cables connecting to the Kinetix 6000 drive components.

Table 14 - IAM Module (converter side)

Wire/Cable	Connector	Zone			Method	
		Very Dirty	Dirty	Clean	Ferrite Sleeve	Shielded Cable
CTRL 1 and 2	CPD		X			
DC-/DC+ (unshielded cable)	IPD	X				
L1, L2, L3 (shielded cable)			X			X
L1, L2, L3 (unshielded cable)		X				
CONT EN- and CONT EN+ (M1 contactor)	CED		X			
DPI	DPI			X		X

Table 15 - AM Module or Axis Module (inverter side)

Wire/Cable	Connector	Zone			Method	
		Very Dirty	Dirty	Clean	Ferrite Sleeve	Shielded Cable
U, V, W (motor power)	MP		X			X
MBRK-, MBRK+ (motor brake)	BC		X			
MBRK-, MBRK+ (motor brake) 1326AB motors with resolver feedback			X		X	
DBRK-, DBRK+ (resistive brake)			X			
COM, PWR (24V DC), filtered ⁽¹⁾					X	
COM, PWR (24V DC), unfiltered ⁽²⁾			X			
COM, PWR (24V DC), safety enable, and feedback signals for safe torque-off feature	STO		X			
Motor feedback	MF			X		X
Auxiliary feedback	AF			X		X
Registration and analog outputs	IOD			X		X
Others			X			
Fiber-optic	Rx and Tx	No restrictions				

(1) This is a clean 24V DC available for any device that requires it.

(2) This is a dirty 24V DC available for motor brakes and contactors.

Table 16 - Line Interface Module (LIM)

Wire/Cable	Connector	Zone			Method	
		Very Dirty	Dirty	Clean	Ferrite Sleeve	Shielded Cable
VAC line (main input)	IPL		X			
Aux power input	APL		X			
VAC load (shielded option)	OPL		X			X
VAC load (unshielded option)		X				
Control power output	CPL		X			
MBRK PWR, MBRK COM	P1L/PSL		X			
Status I/O	IOL		X			
Aux power output	P2L		X			

Table 17 - Shunt Module

Wire/Cable	Connector	Zone			Method	
		Very Dirty	Dirty	Clean	Ferrite Sleeve	Shielded Cable
COL, DC+ (shielded option)	RC		X			X
COL, DC+ (unshielded option)		X				
Thermal switch	TS		X			X
Fan (if present)	N/A		X			

Table 18 - IDM Power Interface Module (IPIM)

Wire/Cable	Zone			Method	
	Very Dirty	Dirty	Clean	Ferrite Sleeve	Shielded Cable
Hybrid DC bus power, control power, inter-module communication, and safe torque-off ⁽¹⁾		X			X
Enable input			X		X
Fiber-optic	No restrictions				
Ethernet network			X		X
IDM network ⁽¹⁾			X		X

(1) There is no option for making your own hybrid power or IDM network cables.

Table 19 - Resistive Brake Module (RBM)

Wire/Cable	Connections	Zone			Method	
		Very Dirty	Dirty	Clean	Ferrite Sleeve	Shielded Cable
Resistive brake module coil power	TB3-6 and TB3-7		X			
Resistive brake module I/O	TB1-1...TB1-5 and TB3-8		X			
Resistive brake module drive and motor power	TB1 and TB2		X			X
230V power	TB4		X			

Noise Reduction Guidelines for Drive Accessories

Refer to this section when mounting an AC (EMC) line filter or external shunt module for guidelines designed to reduce system failures caused by excessive electrical noise.

AC Line Filters

Observe these guidelines when mounting your AC (EMC) line filter (refer to the figure on [page 44](#) for an example):

- Mount the AC line filter on the same panel as the Kinetix 6000 drive and as close to the power rail as possible.
- Good HF bonding to the panel is critical. For painted panels, refer to the examples on [page 35](#).
- Segregate input and output wiring as far as possible.

IMPORTANT CE test certification applies only to AC line filter and single power rail. Sharing a line filter with multiple power rails can perform satisfactorily, but the user takes legal responsibility.

External Shunt Modules

Observe these guidelines when mounting your external shunt module outside the enclosure:

- Mount circuit components and wiring in the very dirty zone or in an external shielded enclosure. Run shunt power and fan wiring inside metal conduit to minimize the effects of EMI and RFI.
- Mount resistors (other than metal-clad) in a shielded and ventilated enclosure outside the cabinet.
- Keep unshielded wiring as short as possible. Keep shunt wiring as flat to the cabinet as possible.
- Route thermal switch and fan wires separate from shunt power.

Figure 19 - External Shunt Module Outside the Enclosure

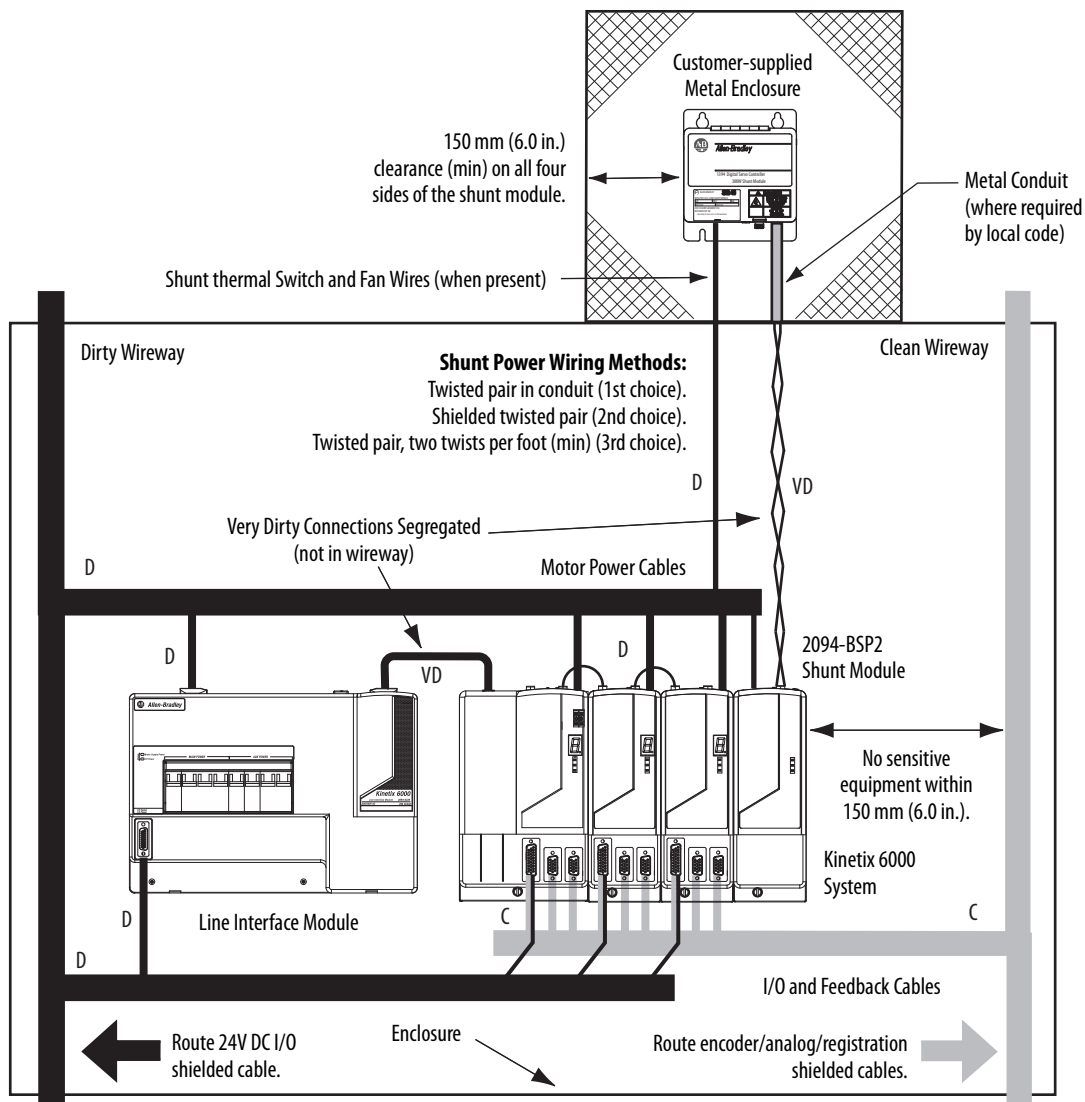

When mounting your shunt module inside the enclosure, follow these additional guidelines:

- Mount metal-clad modules anywhere in the dirty zone, but as close to the Bulletin 2094 drive system as possible.
- Route shunt power wires with motor power cables.
- Keep unshielded wiring as short as possible. Keep shunt wiring as flat to the cabinet as possible.
- Separate shunt power cables from other sensitive, low voltage signal cables.

Figure 20 - External Shunt Module Inside the Enclosure

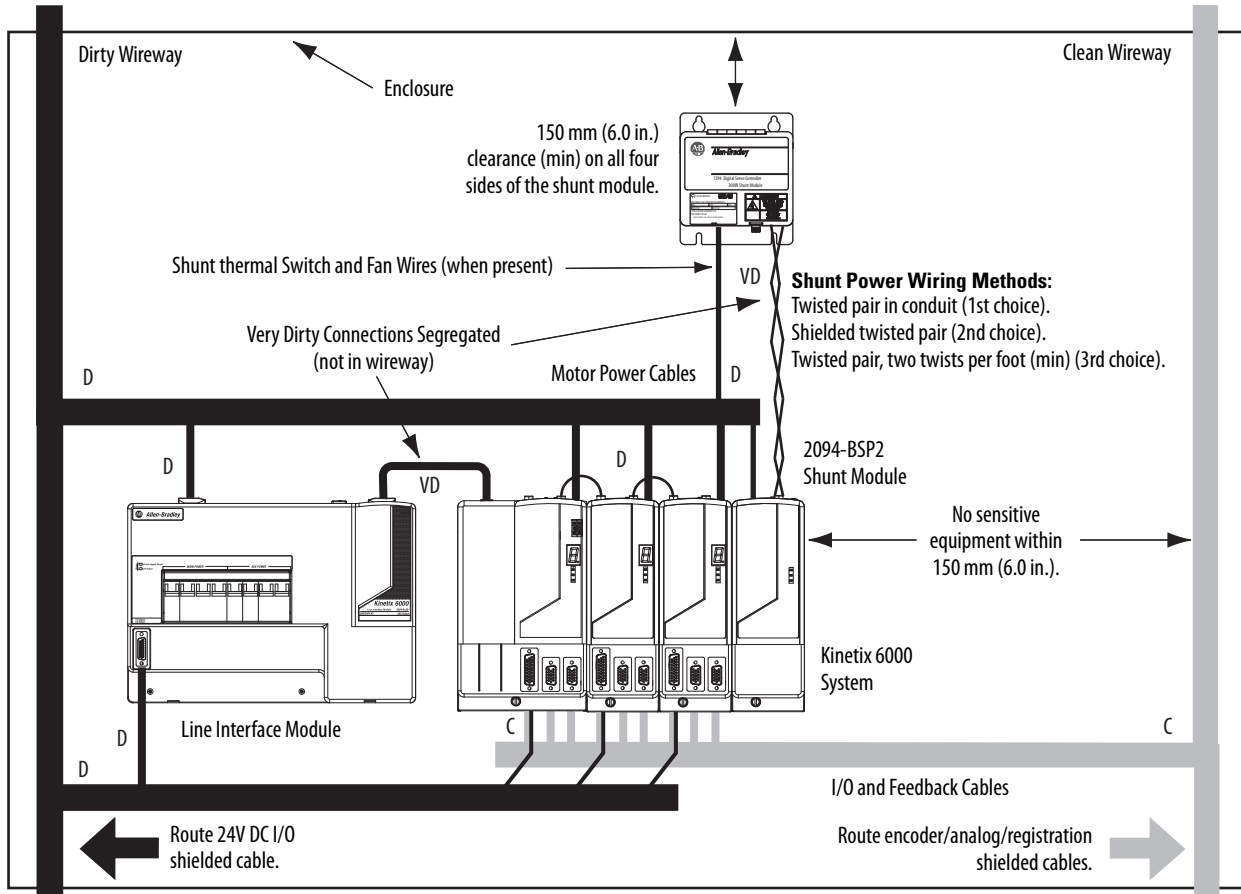

Resistive Brake Modules

Observe these guidelines when mounting your RBM module:

- Mount circuit components and wiring in the dirty zone or in an external shielded enclosure. If mounting the RBM module in a separate ventilated shielded enclosure, run wiring inside metal conduit to minimize the effects of EMI and RFI.
- Keep unshielded wiring as short as possible. Keep wiring as flat to the cabinet as possible.
- Route RBM module power and I/O cables separate from other sensitive low voltage signal cables.

Figure 21 - Noise Zones (RBM mounted above AM module)

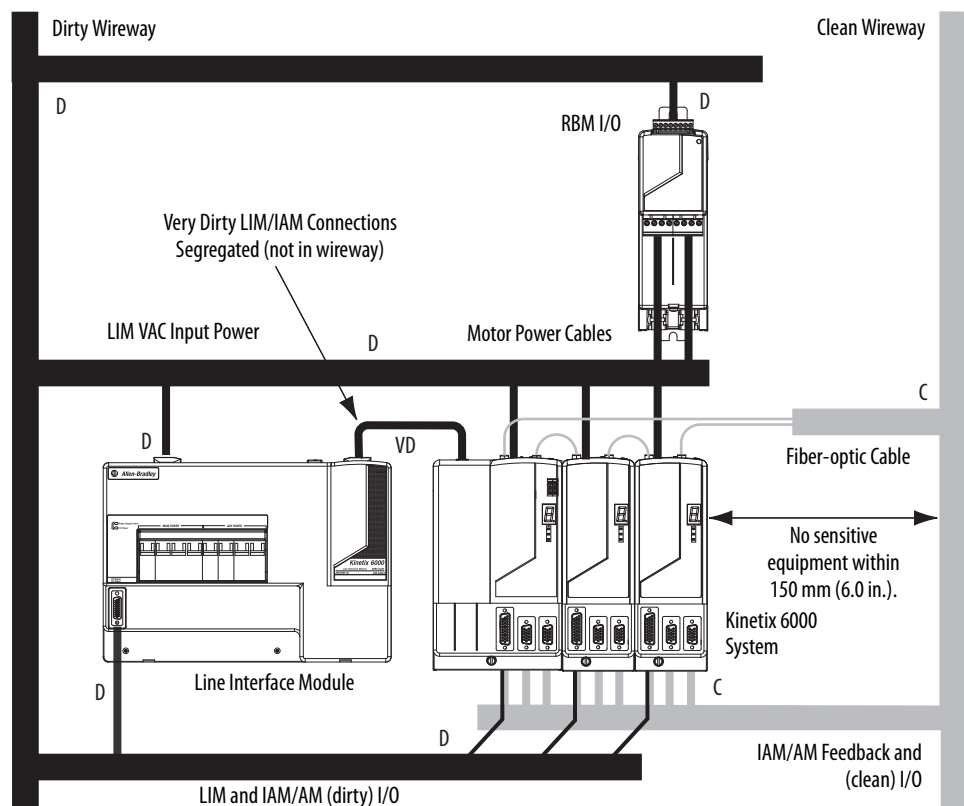

Motor Brake and Thermal Switch

The thermal switch and brake are mounted inside the motor, but how you connect to the axis module depends on the motor series.

Refer to [Wire the Motor/Resistive Brake \(BC\) Connector on page 111](#) for wiring guidelines. Refer to [Axis Module/Rotary Motor Wiring Examples beginning on page 196](#) for the interconnect diagram of your drive/motor combination.

Mounting the Kinetix 6000 Drive System

This chapter provides the system installation procedures for mounting your Kinetix 6000 drive components on the Bulletin 2094 power rail.

Topic	Page
Before You Begin	51
Determine Mounting Order	52
Mount Modules on the Power Rail	54

This procedure assumes you have prepared your panel, mounted your Bulletin 2094 power rail, and understand how to bond your system. For installation instructions regarding equipment and accessories not included here, refer to the instructions that came with those products.



SHOCK HAZARD: To avoid hazard of electrical shock, perform all mounting and wiring of the Bulletin 2094 power rail and drive modules prior to applying power. Once power is applied, connector terminals can have voltage present even when not in use.



ATTENTION: Plan the installation of your system so that you can perform all cutting, drilling, tapping, and welding with the system removed from the enclosure. Because the system is of the open type construction, be careful to keep any metal debris from falling into it. Metal debris or other foreign matter can become lodged in the circuitry, which can result in damage to components.

Before You Begin

Before you begin, consider your Bulletin 2094 power rail installation and using 2094 mounting brackets.

Using the 2094 Mounting Brackets

You can use Bulletin 2094 mounting brackets to mount the power rail or LIM module over the AC line filter. Refer to the 2094 Mounting Brackets Installation Instructions, publication [2094-IN008](#), when using mounting brackets with your Kinetix 6000 drive system.

Installing the 2094 Power Rail

The Bulletin 2094 power rail comes in lengths to support one IAM module and up to seven additional AM/IPIM modules, or up to six additional AM/IPIM modules and one shunt module. The connector pins for each slot are covered by a protective cover. The cover is designed to protect the pins from damage and make sure that no foreign objects lodge between the pins during installation. Refer to the Kinetix 6000 Power Rail Installation Instructions, publication [2094-IN003](#), when installing your power rail.



ATTENTION: To avoid damage to the power rail during installation, do not remove the protective covers until the module for each slot is ready for mounting.

The Kinetix 6000M integrated drive-motor (IDM) system is supported by Bulletin 2094 (400V-class) power rail configurations. You can mount up to four IDM power interface (IPIM) modules on the Bulletin 2094 power rail. Refer to the Kinetix 6000M Integrated Drive-Motor System User Manual, publication [2094-UM003](#), for more information.

Determine Mounting Order

Mount IAM, AM/IPIM, shunt, and slot-filler modules in the order (left to right) as shown in [Figure 22](#). Mount axis modules and the IPIM module according to power utilization (highest to lowest) from left to right starting with the highest power utilization.

Power utilization is the average power (kW) consumed by a servo axis. If Motion Analyzer software was used to size the axis, the calculated axis power required can be used for the power utilization value. If Motion Analyzer software was not used, you can use the continuous power value (kW) for each module to determine mounting order.

Table 20 - Kinetix 6000 (200V-class) Axis Modules

Attribute	2094-AMP5-S	2094-AM01-S	2094-AM02-S	2094-AM03-S	2094-AM05-S
Continuous Power Output, nom	1.2 kW	1.9 kW	3.4 kW	5.5 kW	11.0 kW

Table 21 - Kinetix 6000 (400V-class) Axis Modules

Attribute	2094-BMP5-S	2094-BM01-S	2094-BM02-S	2094-BM03-S	2094-BM05-S
Continuous Power Output, nom	1.8 kW	3.9 kW	6.6 kW	13.5 kW	22.0 kW

Table 22 - Kinetix 6000M (400V-class) IPIM Module

Attribute	2094-SEPM-B24-S
Continuous Power Output, nom	15.0 kW

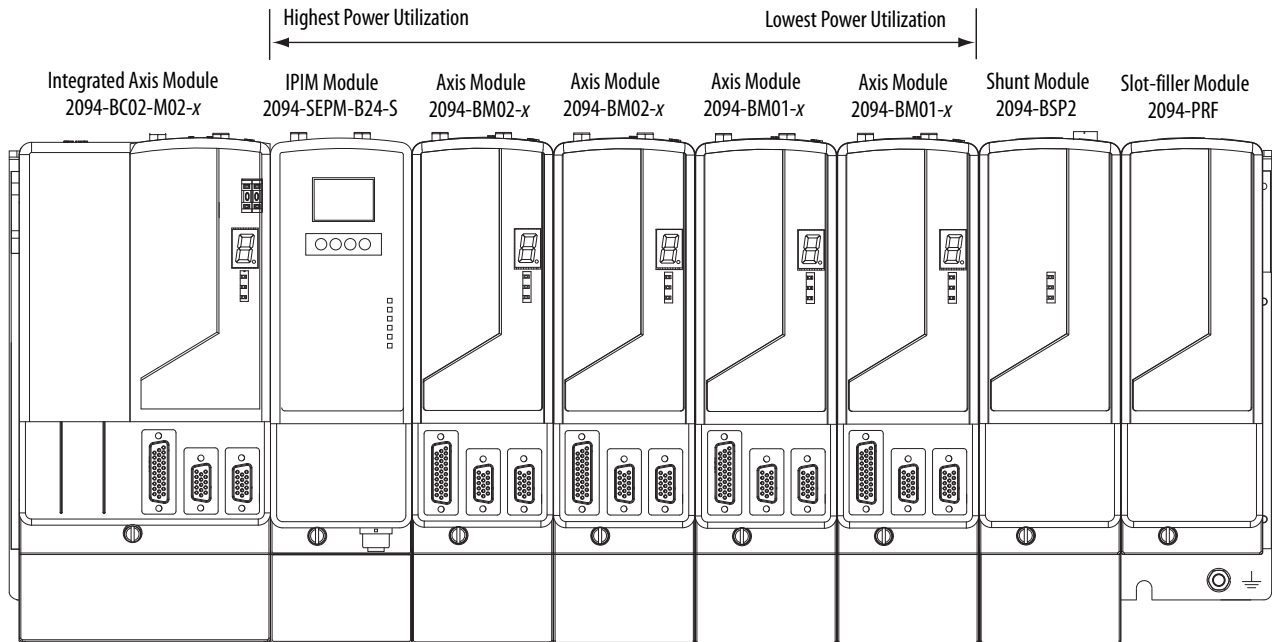
Figure 22 - Module Mounting Order Example**IMPORTANT**

The IAM module must be positioned in the leftmost slot of the power rail. Position your AM/IPIM modules, shunt module, and slot-filler modules to the right of the IAM module.

The shunt module must be installed to the right of the last AM/IPIM module. Only slot-filler modules can be installed to the right of the shunt module.

Do not mount the shunt module on power rails with a follower IAM module. Common-bus follower IAM modules disable the internal, rail mounted, and external shunt modules.



SHOCK HAZARD: To avoid personal injury due to electrical shock, place a 2094-PRF slot-filler module in all empty slots on the power rail. Any power rail connector without a module installed disables the Bulletin 2094 system; however, control power is still present.

Mount Modules on the Power Rail

Follow these steps to mount the IAM, AM, IPIM, shunt, and slot-filler modules.

TIP All modules mount to the power rail by using the same technique; however, only the IAM module is used in the examples.

1. Remove the protective covers from the power rail connectors.

IMPORTANT The IAM module must be positioned in the leftmost slot of the power rail. Position your axis modules, shunt module, and slot-filler modules to the right of the IAM module.

2. Determine the next available slot and module for mounting.



ATTENTION: To avoid damage to the pins on the back of each IAM, AM, IPIM, shunt, and slot-filler module and to make sure that module pins mate properly with the power rail, hang modules as shown in [step 3](#) through [step 6](#).

The power rail must be mounted vertically on the panel before hanging modules on the power rail. Do not mount modules if the power rail is horizontal.

3. Hang the mounting bracket from the slot on the power rail.

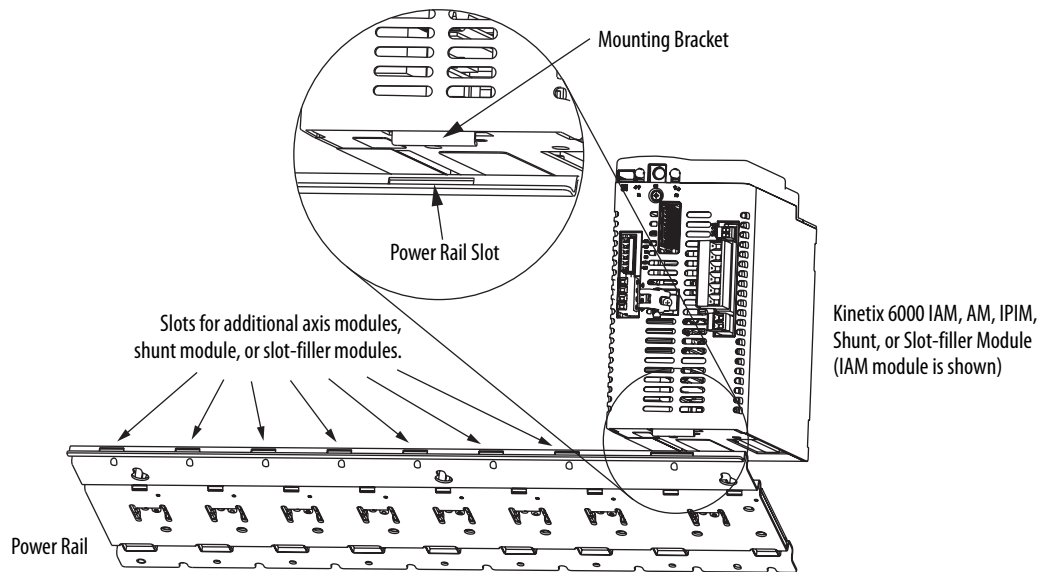

- Pivot module downward and align the guide pins on the power rail with the guide pin holes in the back of the module.

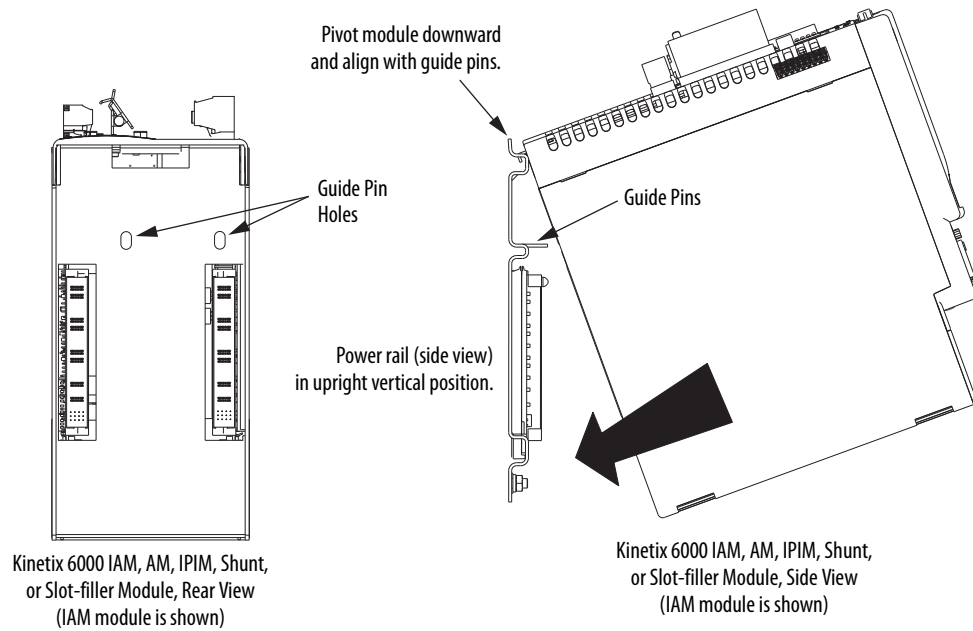

TIP The IAM module can have two or three power rail connectors and guide pins, the AM module can have one or two, all other modules have one.

- Gently push the module against the power rail connectors and into the final mounting position.

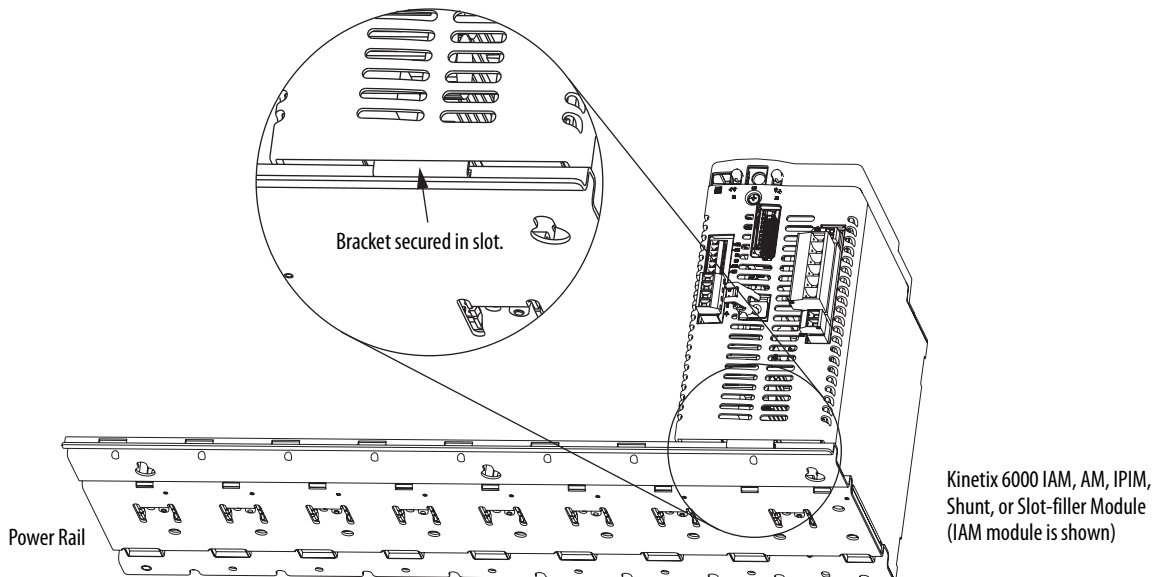

6. Use 2.26 N•m (20 lb•in) torque to tighten the mounting screws.

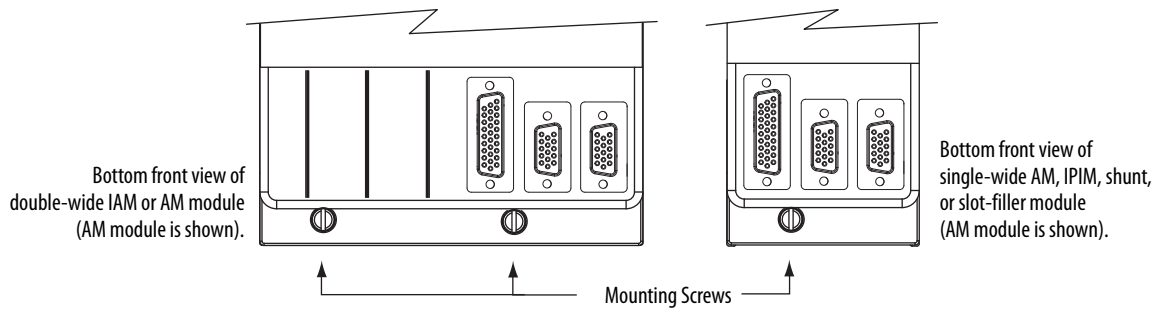

IMPORTANT There are two mounting screws when mounting 2094-AC32-M05-*x*, 2094-BC04-M03-*x*, and 2094-BC07-M05-*x* (double-wide) IAM modules, and 2094-BM03-*x* and 2094-BM05-*x* (double-wide) AM modules.

Repeat [step 1](#) through [step 6](#) for each AM, IPIM, shunt, or slot-filler module in your Bulletin 2094 drive system

Connector Data and Feature Descriptions

This chapter illustrates drive connectors and indicators, including connector pinouts, and provides descriptions for Kinetix 6000 drive features.

Topic	Page
2094 IAM/AM Module Connector Data	58
Control Signal Specifications	67
Power and Relay Specifications	71
Feedback Specifications	77

For the Kinetix 6000M integrated drive-motor (IDM) unit and IDM power interface module (IPIM) connector locations and signal descriptions, refer to the Kinetix 6000M Integrated Drive-Motor System User Manual, publication [2094-UM003](#).

2094 IAM/AM Module Connector Data

Use these illustrations to identify the connectors and indicators for the IAM/AM modules. Sercos interface and Ethernet network connectors for the Kinetix 6000M IPIM module are also shown. For the remainder of the IPIM module features and indicators, refer to the Kinetix 6000M Integrated Drive-Motor System User Manual, publication [2094-UM003](#).

Although the physical size of the 400V-class module is larger than the 200V-class module, the location of the features and indicators is identical.

Figure 23 - Integrated Axis Module Features and Indicators

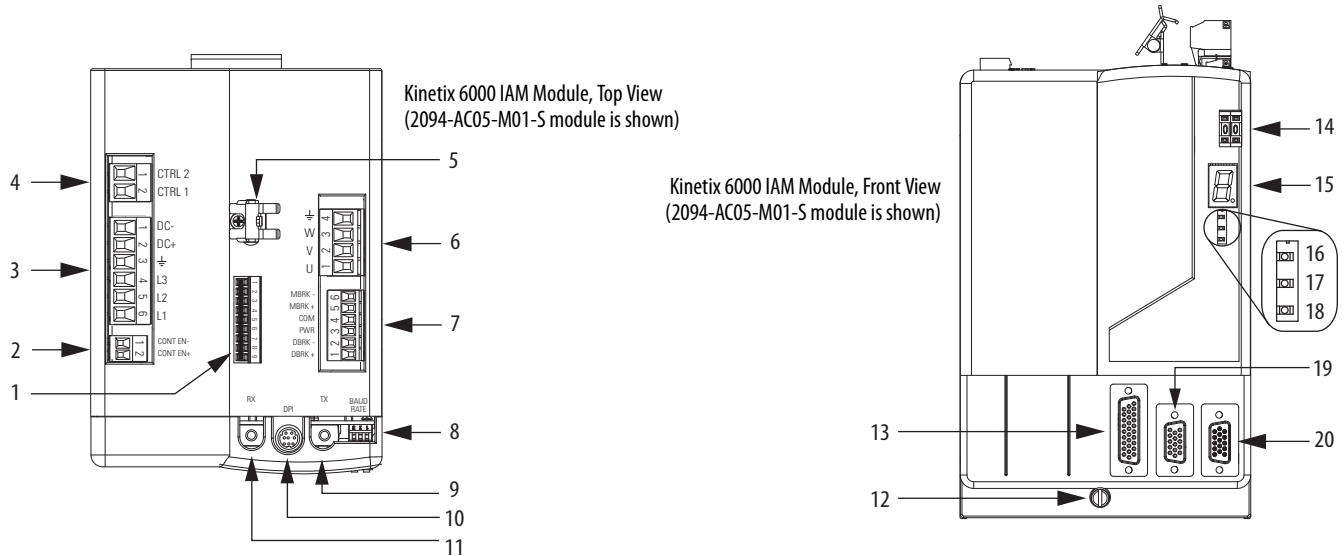

Item	Description
1	Safe torque-off (STO) connector
2	Contactorm enable (CED) connector
3	DC bus/AC input power (IPD) connector
4	Control power (CPD) connector
5	Motor cable shield clamp
6	Motor power (MP) connector
7	Motor/resistive brake (BC) connector
8	Sercos communication rate and optical power switches
9	Sercos transmit (Tx) connector
10	DPI connector

Item	Description
11	Sercos receive (Rx) connector
12	Mounting screw
13	I/O (IOD) connector
14	Sercos node address switch
15	Seven-segment fault status indicator
16	Drive status indicator
17	COMM status indicator
18	Bus status indicator
19	Motor feedback (MF) connector
20	Auxiliary feedback (AF) connector

Figure 24 - Axis Module Features and Indicators

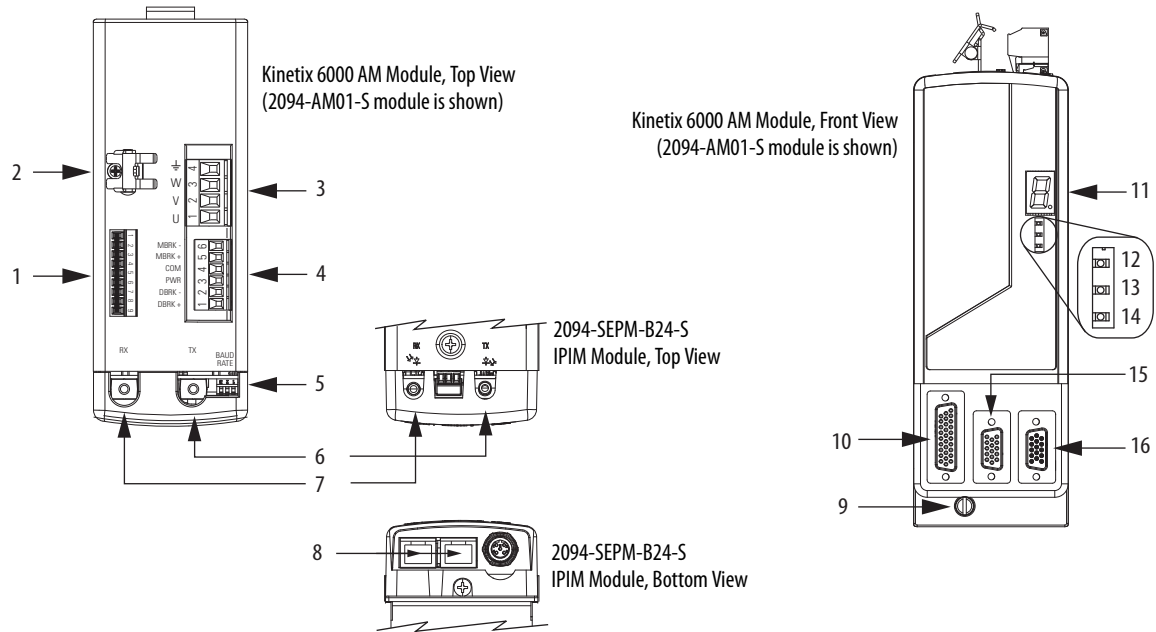

Item	Description
1	Safe torque-off (STO) connector
2	Motor cable shield clamp
3	Motor power (MP) connector
4	Motor/resistive brake (BC) connector
5	Sercos communication rate and optical power switches
6	Sercos transmit (Tx) connector ⁽¹⁾
7	Sercos receive (Rx) connector ⁽¹⁾
8	Ethernet (PORT1 and PORT 2) connectors ⁽²⁾

Item	Description
9	Mounting screw
10	I/O (IOD) connector
11	Seven-segment fault status indicator
12	Drive status indicator
13	COMM status indicator
14	Bus status indicator
15	Motor feedback (MF) connector
16	Auxiliary feedback (AF) connector

- (1) The Rx and Tx sercos connectors on the Kinetix 6000M IPIM module are in the same position as on the Kinetix 6000 AM modules. For the remainder of the IPIM module features and indicators, refer to the Kinetix 6000M Integrated Drive–Motor System User Manual, publication [2094-UM003](#).
- (2) The Kinetix 6000M IPIM module has two Ethernet ports. These ports are used only for connecting to the EtherNet/IP network for Logix5000 programming.

Table 23 - Kinetix 6000 IAM/AM Module Connectors

Designator	Description	Connector	Module
IOD	User I/O (drive)	26-pin high-density D-shell (female)	IAM/AM
MF	Motor feedback	15-pin high-density D-shell (female)	IAM/AM
AF	Auxiliary feedback	15-pin high-density D-shell (male)	IAM/AM
CPD	Control input power (drive)	2-position plug/header	IAM
IPD	VAC input power (drive) and DC bus	6-position plug/header	IAM
CED	Contactorm enable	2-position plug/header	IAM
MP	Motor power	4-position plug/header	IAM/AM
BC	Motor/Resistive brake	6-position plug/header	IAM/AM
STO	Safe torque-off	9-position plug/header	IAM/AM
Tx and Rx	Sercos transmit and receive	Sercos fiber-optic (2)	IAM/AM
DPI	DPI	DPI	IAM

Safe Torque-off Connector Pinout

Each 2094-*x*C*xx*-M*xx*-S IAM module and 2094-*x*M*xx*-S AM module ships with the (9-pin) wiring-plug header and motion-allowed jumper installed in the safe torque-off (STO) connector. With the motion-allowed jumper installed, the safe torque-off feature is not used.

Figure 25 - Motion-allowed Jumper

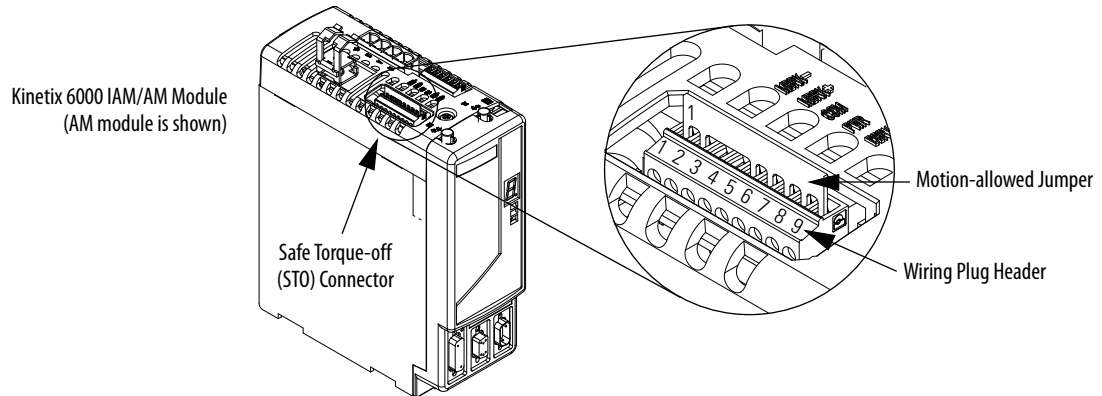

Headers in this table extend the safe torque-off (STO) connector signals for use in wiring single and multiple safe torque-off drive configurations, or to defeat (not use) the safe torque-off feature.

Table 24 - IAM/AM Safe Torque-off 9-pin (STO) Connector

Safe Torque-off (STO) Connector Pin	Applies to These STO Connector Headers	Description	Signal
1	<ul style="list-style-type: none"> Wiring plug header used in single-drive applications First-drive wiring header (catalog number 2090-XNSM-W) used in multiple-drive applications 	One side of the normally-closed monitoring contact of relay 2	FDBK2+
2		Other side of the normally-closed monitoring contact of relay 2	FDBK2-
3		One side of the normally-closed monitoring contact of relay 1	FDBK1+
4		Other side of the normally-closed monitoring contact of relay 1	FDBK1-
5		Safety enable 2 input	SAFETY ENABLE2+
6		Return for safety enable power (both inputs)	SAFETY ENABLE-
7		Safety enable 1 input	SAFETY ENABLE1+
8	<ul style="list-style-type: none"> Wiring plug header Motion-allowed jumper 	Power for continuous enable of the safety function, 500 mA max	24V+
9		Power return used for continuous enable of safety function	24V_COM

IMPORTANT Pins STO-8 and STO-9 (24V+) are used by only the motion-allowed jumper. When wiring to the wiring-plug header, the 24V supply must come from an external source.

Refer to the Kinetix Safe Torque-off Feature Safety Reference Manual, publication [GMC-RM002](#), for more information on wiring safe torque-off headers.

I/O Connector Pinout

Table 25 - IAM/AM I/O 26-pin (IOD) Connector

IOD Pin	Description	Signal	IOD Pin	Description	Signal
1	Hardware enable 24V DC power supply	+24V_PWR	14	High speed registration 1 input	REG1
2	Hardware enable input	ENABLE	15	Common for registration	REG_COM
3	Common	+24V_COM	16	24V registration power	REG_24V
4	Home switch 24V DC power supply	+24V_PWR	17	High speed registration 2 input	REG2
5	Home switch input	HOME	18	Common for registration	REG_COM
6	Common	+24V_COM	19	Reserved	–
7	Positive overtravel 24V DC power supply	+24V_PWR	20	Reserved	–
8	Positive overtravel limit switch input	OT+	21	Reserved	–
9	Common	+24V_COM	22	Reserved	–
10	Negative overtravel 24V DC power supply	+24V_PWR	23	Analog output 0	DAC0
11	Negative overtravel limit switch input	OT-	24	Analog output common	DAC_COM
12	Common	+24V_COM	25	Analog output 1	DAC1
13	24V registration power	REG_24V	26	Analog output common	DAC_COM

IMPORTANT Signals +24V_PWR and +24V_COM are a 24V DC source you can use only for the inputs listed above.

Figure 26 - Pin Orientation for 26-pin I/O (IOD) Connector

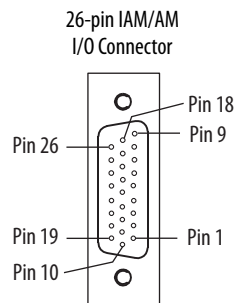

Motor Feedback Connector Pinout

Table 26 - Stegmann Hiperface (SRS/SRM)

MF Pin	Description	Signal
1	Sine differential input+	SIN+
2	Sine differential input-	SIN-
3	Cosine differential input+	COS+
4	Cosine differential input-	COS-
5	Hiperface data channel	DATA+
6	Common	ECOM
7	Encoder power (+9V)	EPWR_9V ⁽²⁾
8	Reserved	–

MF Pin	Description	Signal
9	Reserved	–
10	Hiperface data channel	DATA-
11	Motor thermal switch (normally closed) ⁽¹⁾	TS+
12	Reserved	–
13	Reserved	–
14	Encoder power (+5V)	EPWR_5V ⁽²⁾
15	Reserved	–

- (1) Not applicable unless motor has integrated thermal protection.
Common (TS-) signal for thermal switch is tied to MF-6 (ECOM) in Bulletin 2090 cables.
- (2) Encoder power supply uses either 5V or 9V DC based on encoder/motor used.

Table 27 - TTL or Sine/Cosine with Index Pulse and Hall Commutation

MF Pin	Description	Signal
1	AM+ / Sine differential input+	AM+ / SIN+
2	AM- / Sine differential input-	AM- / SIN-
3	BM+ / Cosine differential input+	BM+ / COS+
4	BM- / Cosine differential input-	BM- / COS-
5	Index pulse+	IM+
6	Common	ECOM
7	Encoder power (+9V)	EPWR_9V ⁽²⁾
8	Single-ended 5V hall effect commutation	S3

MF Pin	Description	Signal
9	Reserved	–
10	Index pulse-	IM-
11	Motor thermal switch (normally closed) ⁽¹⁾	TS+
12	Single-ended 5V hall effect commutation	S1
13	Single-ended 5V hall effect commutation	S2
14	Encoder power (+5V)	EPWR_5V ⁽²⁾
15	Reserved	–

- (1) Not applicable unless motor has integrated thermal protection.
Common (TS-) signal for thermal switch is tied to MF-6 (ECOM) in Bulletin 2090 cables.
- (2) Encoder power supply uses either 5V or 9V DC based on encoder/motor used.

Table 28 - Resolver Transmitter (transformation ratio = 0.25)

MF Pin	Description	Signal
1	Sine differential input+	S2
2	Sine differential input-	S4
3	Cosine differential input+	S1
4	Cosine differential input-	S3
5	Resolver excitation	R1
6	Common	ECOM
7	Reserved	–
8	Reserved	–

MF Pin	Description	Signal
9	Reserved	–
10	Resolver excitation	R2
11	Motor thermal switch (normally closed) ^{(1) (2)}	TS+
12	Reserved	–
13	Reserved	–
14	Reserved	–
15	Reserved	–

- (1) Not applicable unless motor has integrated thermal protection.
Common (TS-) signal for thermal switch is tied to MF-6 (ECOM) in Bulletin 2090 cables.
- (2) If using 1326AB (resolver-based) motors, use 2090-K6CK-D15MF Low-profile Connector Kits that connect the filtered thermal switch (pins 16 and 17) to MF-11 and MF-6.

Kinetix 6000 drives do not support Heidenhain EnDat high-resolution feedback; however, you can use the 2090-K6CK-KENDAT feedback module to convert Heidenhain EnDat high-resolution feedback to Stegmann Hiperface. Pin numbers in the table below refer to pins in the feedback module.

IMPORTANT Only 2094-xCxx-Mxx-S and 2094-xMxx-S drives with firmware revision 1.116 or later support the use of 2090-K6CK-KENDAT feedback modules for Heidenhain EnDat feedback.

Table 29 - Heidenhain EnDat

Pin	Description	Signal
1	Sine differential input+	SIN+
2	Sine differential input-	SIN-
3	Cosine differential input+	COS+
4	Cosine differential input-	COS-
5	Encoder power (+5V)	EPWR_5V
6	Common	ECOM
7	Serial data clock signal +	CLK+

Pin	Description	Signal
8	Serial data clock signal -	CLK-
9	Serial data differential signal+	DATA+
10	Serial data differential signal -	DATA-
11	Motor thermal switch+ ⁽¹⁾	TS+
12	Motor thermal switch- ⁽²⁾	TS-
13	Reserved	-

- (1) Not applicable unless motor has integrated thermal protection.
- (2) When used with Allen-Bradley motors and Bulletin 2090 cables, pin 12 is reserved.

IMPORTANT Combined motor-power cable length for all axes on the same DC bus must not exceed 240 m (787 ft) with 460V systems or 160 m (525 ft) with 230V systems. Drive-to-motor power cables must not exceed 90 m (295.5 ft). System performance was tested at these cable length specifications. These limitations also apply when meeting CE requirements.

Figure 27 - Pin Orientation for 15-pin Motor Feedback (MF) Connector

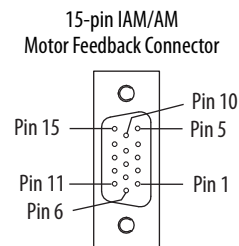

Auxiliary Feedback Connector Pinout

For TTL devices, the position count increases when A leads B. For sinusoidal devices, the position count increases when cosine leads sine.

Table 30 - Stegmann Hiperface (SRS and SRM only)

AF Pin	Description	Signal
1	Sine differential input+	SIN+
2	Sine differential input-	SIN-
3	Cosine differential input+	COS+
4	Cosine differential input-	COS-
5	Hiperface data channel	DATA+
6	Common	ECOM
7	Encoder power (+9V)	EPWR_9V ⁽¹⁾
8	Reserved	–

AF Pin	Description	Signal
9	Reserved	–
10	Hiperface data channel	DATA-
11	Reserved	–
12	Reserved	–
13	Reserved	–
14	Encoder power (+5V)	EPWR_5V ⁽¹⁾
15	Reserved	–

(1) Encoder power supply uses either 5V or 9V DC based on encoder/motor used.

Table 31 - TTL or Sine/Cosine with Index Pulse

AF Pin	Description	Signal
1	A+ / Sine differential input+	A+ / SIN+
2	A- / Sine differential input-	A- / SIN-
3	B+ / Cosine differential input+	B+ / COS+
4	B- / Cosine differential input-	B- / COS-
5	Index pulse+	I+
6	Common	ECOM
7	Encoder power (+9V)	EPWR_9V ⁽¹⁾
8	Reserved	–

AF Pin	Description	Signal
9	Reserved	–
10	Index pulse-	I-
11	Reserved	–
12	Reserved	–
13	Reserved	–
14	Encoder power (+5V)	EPWR_5V ⁽¹⁾
15	Reserved	–

(1) Encoder power supply uses either 5V or 9V DC based on encoder/motor used.

Figure 28 - Pin Orientation for 15-pin Auxiliary Feedback (AF) Connector

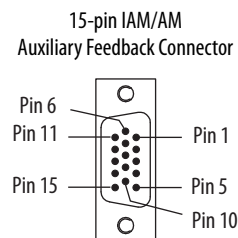

IAM Input Connector Pinout

Table 32 - Control Power Connector

CPD Pin	Description	Signal
1	Control power VAC input	CTRL 2
2		CTRL 1

Table 33 - DC Bus and Input Power Connector

IPD Pin	Description	Signal
1	An integral, unregulated power supply, consisting of AC line input, three-phase bridge rectifier, and filter capacitors.	DC-
2		DC+
3	Chassis ground.	\perp
4	Three-phase input power.	L3
5		L2
6		L1

Table 34 - Contactor Enable Connector

CED Pin	Description	Signal
1	Relay-driven dry contact used in the safety string for a three-phase power contactor.	CONT EN-
2		CONT EN+

IAM and AM Motor Power and Brake Connector Pinout

Table 35 - Motor Power Connector

MP Pin	Description	Signal
4	Chassis ground	\perp
3	Three-phase motor power	W
2		V
1		U

IMPORTANT Combined motor-power cable length for all axes on the same DC bus must not exceed 240 m (787 ft) with 460V systems or 160 m (525 ft) with 230V systems. Drive-to-motor power cables must not exceed 90 m (295.5 ft).
System performance was tested at these cable length specifications. These limitations also apply when meeting CE requirements.

Table 36 - Motor Brake/Resistive Brake Connector

BC Pin	Description	Signal
6	Motor brake connections	MBRK-
5		MBRK+
4	Motor brake common	COM
3	+24V brake input power (from LIM module or customer supplied)	PWR
2	RBM module connections (from RBM module and safety string)	DBRK-
1		DBRK+

Control Signal Specifications

This section provides a description of the Kinetix 6000 drive I/O (IOD), communication, contactor enable (CED), brake (BC), and control power (CPD) connectors.

Digital Inputs

Two fast registration inputs and four other inputs are available for the machine interface on the IAM module and AM module. Each IAM and AM module supplies 24V DC @ 250 mA for the purpose of registration, home, enable, over-travel positive, and over-travel negative inputs. These are sinking inputs that require a sourcing device. A 24V DC power and common connection is provided for each input.

IMPORTANT To improve registration input EMC performance, refer to the System Design for Control of Electrical Noise Reference Manual, publication [GMC-RM001](#).

IMPORTANT Over-travel limit input devices must be normally closed.

Table 37 - Understanding Digital Inputs

IOD Pin	Signal	Description	Capture Time	Edge/Level Sensitive
IOD-2	ENABLE	Optically isolated, single-ended active high signal. Current loading is nominally 10 mA. A 24V DC input is applied to this terminal to enable each axis.	20 ms	Level
IOD-5	HOME	Optically isolated, single-ended active high signal. Current loading is nominally 10 mA. Home switch (normally open contact) inputs for each axis require 24V DC (nominal).	20 ms	Level
IOD-14 IOD-17	REG1 REG2	Fast registration inputs are required to inform the motor interface to capture the positional information with less than 3 μ s uncertainty. Optically isolated, single-ended active high signal. Current loading is nominally 10 mA. A 24V DC input is applied to this terminal to enable each axis.	500 ns	Edge
IOD-8 IOD-11	OT+ OT-	Overtravel detection is available as an optically isolated, single-ended active high signal. Current loading is nominally 10 mA per input. The pos/neg limit switch (normally closed contact) inputs for each axis require 24V DC (nominal).	30 ms	Level

Table 38 - Digital Input Specifications

Parameter	Description	Min	Max
On-state voltage	Voltage applied to the input, with respect to IOCOM, to guarantee an on-state.	ENABLE, HOME, and OT+/-OT-	10.8V
		REG1 and REG2	21.6V
On-state current	Current flow to guarantee an on-state.	3.0 mA	10.0 mA
Off-state voltage	Voltage applied to the input, with respect to IOCOM, to guarantee an off-state.	-1.0V	3.0V

Figure 29 - Enable, Home, and Overtravel Digital Input Circuits

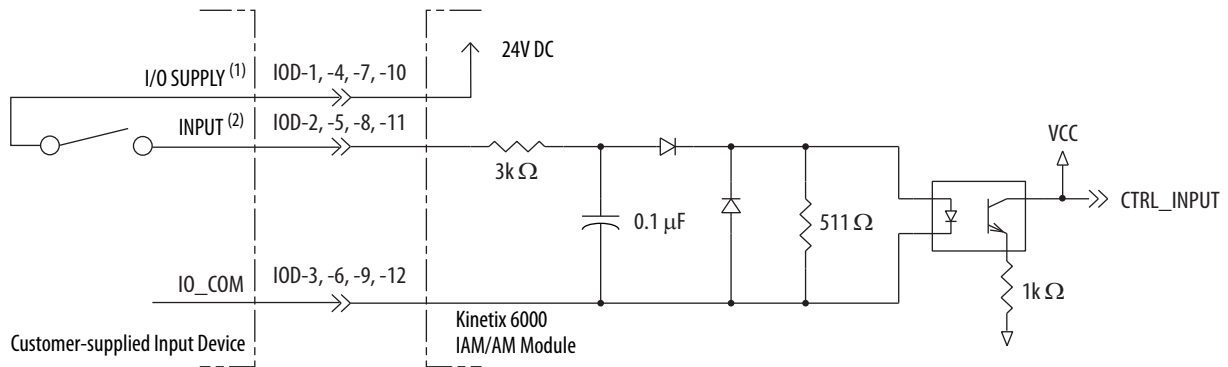

- (1) 24V DC source (range) = 21.6V - 26.4V (supplied by drive, not to exceed 250 mA total).
- (2) Maximum current input = 10 mA.

Figure 30 - Registration Digital Input Circuits

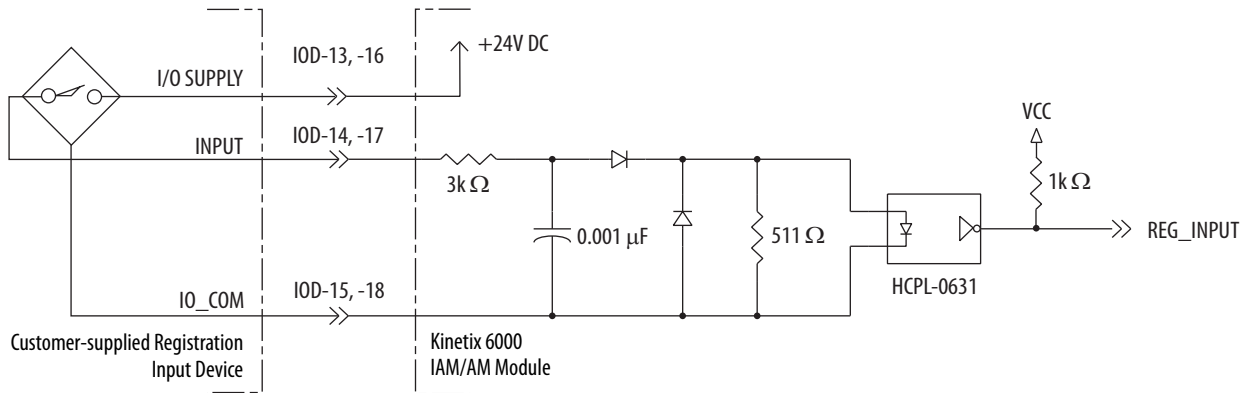

Sercos Communication Specifications

The Rx and Tx sercos connectors are provided on the Kinetix 6000 IAM and AM module for communication with the Logix5000 controller.

Attribute	Value
Data rates	4 and 8 Mbps, selectable via DIP switch ⁽¹⁾
Light intensity	Low power or high power, selectable via DIP switch
Cyclic update period	500 μs, min
Node addresses	01...99 ⁽²⁾

- (1) The Kinetix 6000M IDM system supports only 8 Mbps and is hardwired for this setting.
- (2) Node address assignments begin with the IAM module. Node addresses for additional axes on the same power rail are assigned by incrementing from left to right (starting with the IAM module address). Each IDM unit has its own node address switches and can be set to any valid address. However, node addresses for the IAM and AM modules on the power rail and for IDM units must be unique.

Analog Outputs

The IAM and AM modules include two analog outputs (IOD-23 and IOD-25) that you can configure through software to represent drive variables.

Figure 31 - Analog Output Circuit

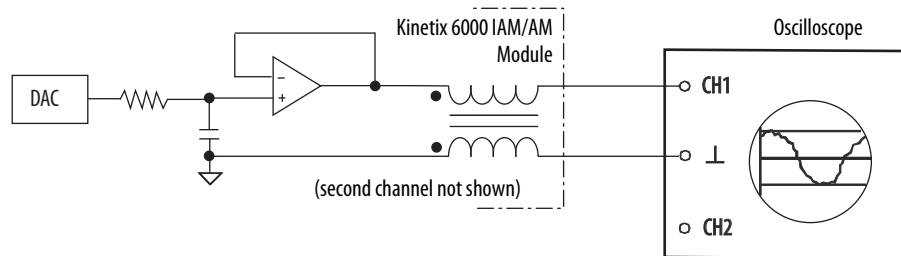

IMPORTANT Output values can vary during powerup until the specified power supply voltage is reached.

Table 39 - Analog Output Specifications

Parameter	Description	Min	Max	
Resolution	Number of states that the output signal is divided into, which is $2^{\text{(to the number of bits)}}$.	–	±11 bits	
Output current	Current capability of the output.	0	+2 mA	
Output signal range	Range of the output voltage.	2094-xCxx-Mxx and 2094-xMxx drives	0	+5V
		2094-xCxx-Mxx-S and 2094-xMxx-S drives	0	+10V
Offset error	Deviation when the output is expected to be at 0V.	–	1 mV	
Bandwidth	Frequency response of the analog output	DC	7.2k Hz (3 db)	

Table 40 - Linear Scaling Specifications

Drive Cat. No.	Speed rpm	Value V DC	Torque %
2094-xCxx-Mxx or 2094-xMxx	10,000	5.0	1000
	0	2.5	0
	-10,000	0	-1000
2094-xCxx-Mxx-S or 2094-xMxx-S	10,000	10.0	1000
	0	5.0	0
	-10,000	0	-1000

For configuration/set up of the analog outputs, refer to Configure Drive Parameters and System Variables beginning on [page 160](#).

Contactor Enable Relay

Contactor enable is a relay-driven contact used in the protective control string to protect the drive electronics during certain fault conditions. It is capable of handling 120V AC or 24V DC at 1 A or less. Contactor enable is a function of the converter and is not available in the axis modules. An active state indicates the drive is operational and does not have a fault.



ATTENTION: Wiring the contactor enable relay is required. To avoid personal injury or damage to the drive, wire the contactor enable relay into your safety control string so that:

- three-phase power is removed from the drive in the event of shutdown fault conditions.
- drive operation is prevented when the power rail is not fully populated.
- control power is applied to the drive prior to three-phase power.

Refer to IAM Module (without LIM module) on [page 190](#) for a wiring example.

IMPORTANT All power rail slots must have a module installed or the contactor enable relay does not close.

Figure 32 - Contactor Enable Relay Circuit

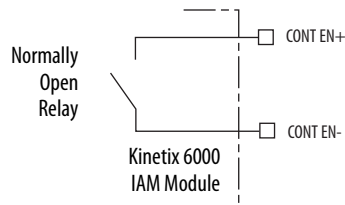

Table 41 - Contactor Enable Relay Output Specifications

Attribute	Value	Min	Max
On-state current	Current flow when the relay is closed	–	1 A
On-state resistance	Contact resistance when the relay is closed	–	1 Ω
Off-state voltage	Voltage across the contacts when the relay is open	–	120V AC or 24V DC

Power and Relay Specifications

This section provides a description of the Kinetix 6000 brake relay (BC), input power (IPD), motor power (MP), and control power (CPD) connectors.

Motor/Resistive Brake Relay

Series C brake circuits use solid-state relays. Series A and B drive modules used mechanical relays. The solid-state brake driver circuit provides the following:

- Brake thermal overload protection
- Brake current overload protection
- Brake short circuit protection

Two connections are required for the (customer-supplied) motor/resistive brake input power (BC-3 and BC-4) and two connections each for the motor and resistive brake output, as shown in [Figure 33](#). Wiring is consistent with all series releases. Connections are rated for +24V and current as shown in [Table 42](#).

An active signal releases the motor brake (BC-5 and BC-6). The brake signal turn-on and turn-off delays are specified by the brake active delay and brake inactive delay (configurable in the Logix Designer application). Refer to the Axis Module/Rotary Motor Wiring Examples beginning on [page 196](#) and the Controlling a Brake Example on [page 211](#) for wiring examples.

The resistive brake relay (BC-1 and BC-2) controls the resistive brake module (RBM) contactor. The RBM module is wired between the drive and motor by using an internal contactor to switch the motor between the drive and a resistive load. The RBM module contact delay is the time it takes to fully close the contactor across the motor power input lines, and must be configured in the software. Refer to RBM Module Interconnect Diagrams beginning on [page 265](#) for wiring examples.

Figure 33 - Brake Relay Circuit (series C)

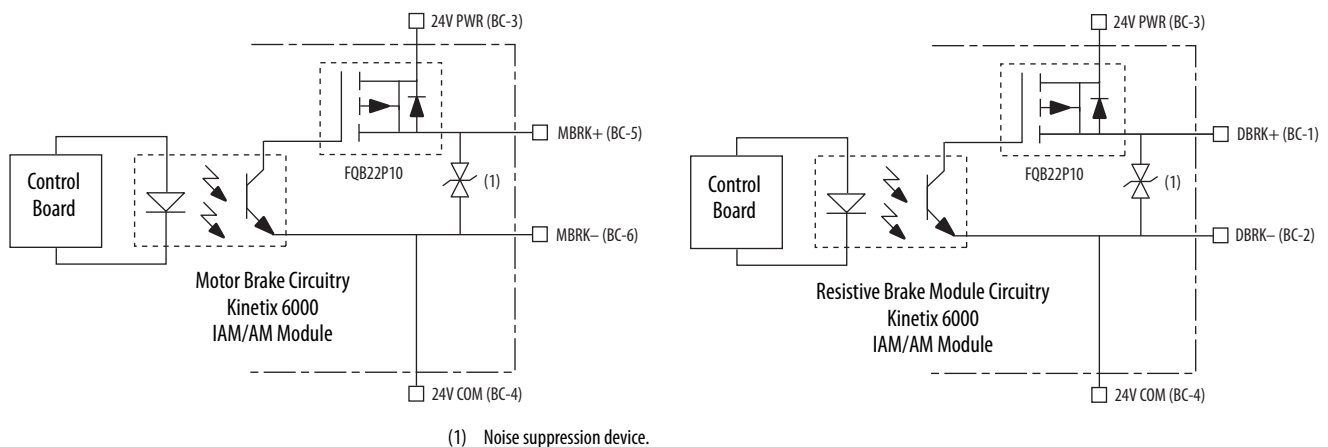

IMPORTANT

Motor parking-brake switching frequency must not exceed 10 cycles/min.

Table 42 - Brake Relay Output Specifications

Attribute	Description	IAM/AM Module	Brake Current Value, max		
			Series A	Series B	Series C
On-state current ⁽¹⁾	Current flow when the relay is closed	2094-AC05-Mxx-x, 2094-AC09-M02-x, 2094-AMP5-x, 2094-AM01-x, 2094-AM02-x	1.0 A	N/A	3.0 A
		2094-BC01-Mxx-x, 2094-BC02-M02-x, 2094-BMP5-x, 2094-BM01-x, 2094-BM02-x		3.0 A	
		2094-AC16-M03-x, 2094-AC32-M05-x, 2094-AM03-x, 2094-AM05-x	1.3 A	N/A	
		2094-BC04-M03-x, 2094-BC07-M05-x, 2094-BM03-x, 2094-BM05-x	3.0 A	3.0 A	
On-state resistance	Contact resistance when the relay is closed		1 Ω		
Off-state voltage	Voltage across the contacts when the relay is open		30V		

(1) For motors requiring more than the maximum current specified, a relay must be added.

Input Power Cycle Capability

The power cycle capability is inversely proportional to the system capacitance (including DC bus follower), but cannot exceed 2 contactor cycles per minute with up to 4 axes or 1 contactor cycle per minute with 5...8 axes.

The cycle capability also depends on the converter power rating and the total system capacitance. Refer to Appendix C on [page 225](#) to calculate total system capacitance.

Table 43 - Maximum Input Power Cycling Specifications (230V)

Attribute	2094-AC05-MP5-S	2094-AC05-M01-S	2094-AC09-M02-S	2094-AC16-M03-S	2094-AC32-M05-S
Main AC input power cycling (cycles per minute for 10,000 µf)	0.69		4.30		

Table 44 - Maximum Input Power Cycling Specifications (460V)

Attribute	2094-BC01-MP5-S	2094-BC01-M01-S	2094-BC02-M02-S	2094-BC04-M03-S	2094-BC07-M05-S
Main AC input power cycling (cycles per minute for 10,000 µf)	0.12		0.52	2.15	4.30

For example, in a 4 axis system with a 2094-BC02-M02-S IAM module and 2,000 µF total capacitance, the calculated capability is $0.52 \times 10,000 / 2000 = 2.6$ cycles per minute. However, this value is reduced to 2.0 by the 4 axes per system limitation.

Peak Enhancement Specifications

Drives that support the Peak-enhanced mode have the capability of increasing the maximum inverter peak current to achieve greater overload performance.

IMPORTANT The peak enhancement feature requires the use of RSLogix 5000 software or the Logix Designer application, and drive firmware as specified in [Table 45](#).

Table 45 - Peak Enhancement Software and Firmware Requirements

IAM Module Cat. No.	AM Module Cat. No.	RSLogix 5000 Software Version	Kinetix 6000 Drive Firmware Revision
2094-BC01-MP5-S	2094-BMP5-S	16 or later	1.111 or later
2094-BC01-M01-S	2094-BM01-S	16 or later	1.111 or later
2094-BC02-M02-S	2094-BM02-S	16 or later	1.111 or later
2094-BC04-M03-S	2094-BM03-S	17 or later	1.117 or later
2094-BC07-M05-S	2094-BM05-S	17 or later	1.117 or later

Table 46 - Kinetix 6000 Inverter Peak Overload Support

Kinetix 6000 Drives Cat. No.	Module	Safe Torque-off Drive	Series A	Series B and C
2094-BCxx-Mxx	IAM	Non Safe Torque-off	Standard	N/A
2094-BMxx	AM			
2094-BCxx-Mxx-S	IAM	Safe Torque-off	Standard	Standard or Peak Enhanced ⁽¹⁾
2094-BMxx-S	AM			

(1) Standard mode is enabled by default to preserve backward compatibility, but you can enable the Peak-enhanced mode to achieve increased peak current performance.

Table 47 - Kinetix 6000 Peak Current Ratings

IAM/AM Module Cat. No.	Peak Inverter Current Rating		Peak Converter Current Rating	
	Standard	Peak Enhanced	Series A	Series B and C
2094-BC01-MP5-S	150%	250%	200%	250%
2094-BC01-M01-S	150%	250%	200%	250%
2094-BC02-M02-S	150%	250%	200%	250%
2094-BC04-M03-S	150%	250%	200%	250%
2094-BC07-M05-S	150%	200%	200%	300%
2094-BMP5-S	150%	250%	N/A	N/A
2094-BM01-S	150%	250%	N/A	N/A
2094-BM02-S	150%	250%	N/A	N/A
2094-BM03-S	150%	250%	N/A	N/A
2094-BM05-S	150%	200%	N/A	N/A

Figure 34 - Load Duty-cycle Profile Example

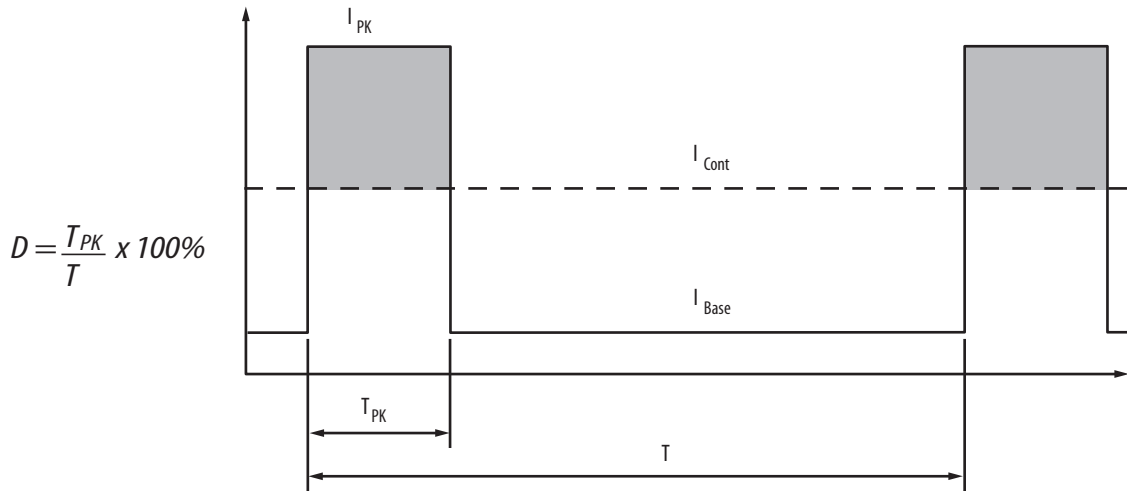
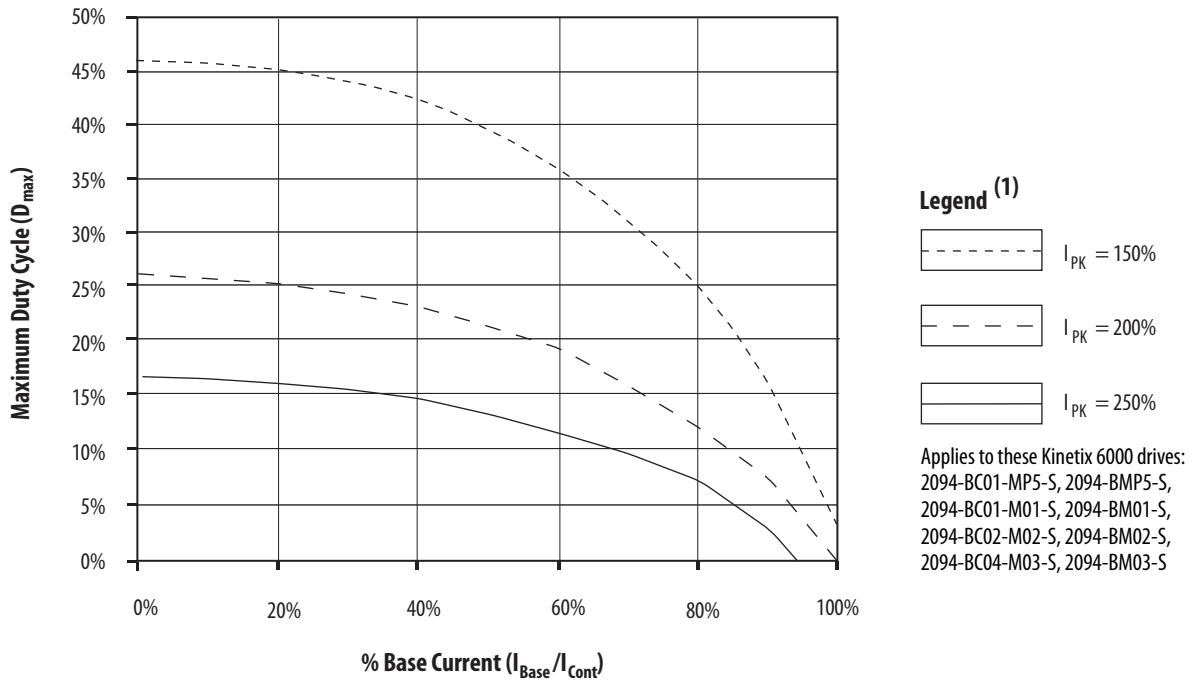

Table 48 - Peak Duty Cycle Definition of Terms

Term	Definition ⁽¹⁾
Continuous Current Rating (I_{Cont})	The maximum value of current that can be output continuously.
Peak Current Rating (I_{PKmax})	The maximum value of peak current that the drive can output. This rating is valid only for overload times less than T_{PKmax} .
Duty Cycle (D)	The ratio of time at peak to the Application Period and is defined as: $D = \frac{T_{PK}}{T} \times 100\%$
Time at Peak (T_{PK})	The time at peak current (I_{PK}) for a given loading profile. Must be less than or equal to T_{PKmax} .
Peak Current (I_{PK})	The level of peak current for a given loading profile. I_{PK} must be less than or equal to the Peak Current Rating (T_{PKMAX}) of the drive.
Base Current (I_{Base})	The level of current between the pulses of peak current for a given loading profile. I_{Base} must be less than or equal to the continuous current rating (I_{Cont}) of the drive.
Loading Profile	The loading profile is comprised of I_{PK} , I_{Base} , T_{PK} , and D (or T) values and completely specify the operation of the drive in an overload situation. These values are collectively defined as the Loading Profile of the drive.
Application Period (T)	The sum of the times at I_{PK} (T_{PK}) and I_{Base} .

(1) All current values are specified as RMS.

Figure 35 - Peak Inverter Overload ($T_{PK} < 2.0$ s)



(1) Base current (I_{Base}) and peak current (I_{PK}) are a percentage of the continuous drive current rating (I_{Cont}).

Figure 36 - Peak Inverter Overload ($T_{PK} < 2.0$ s)

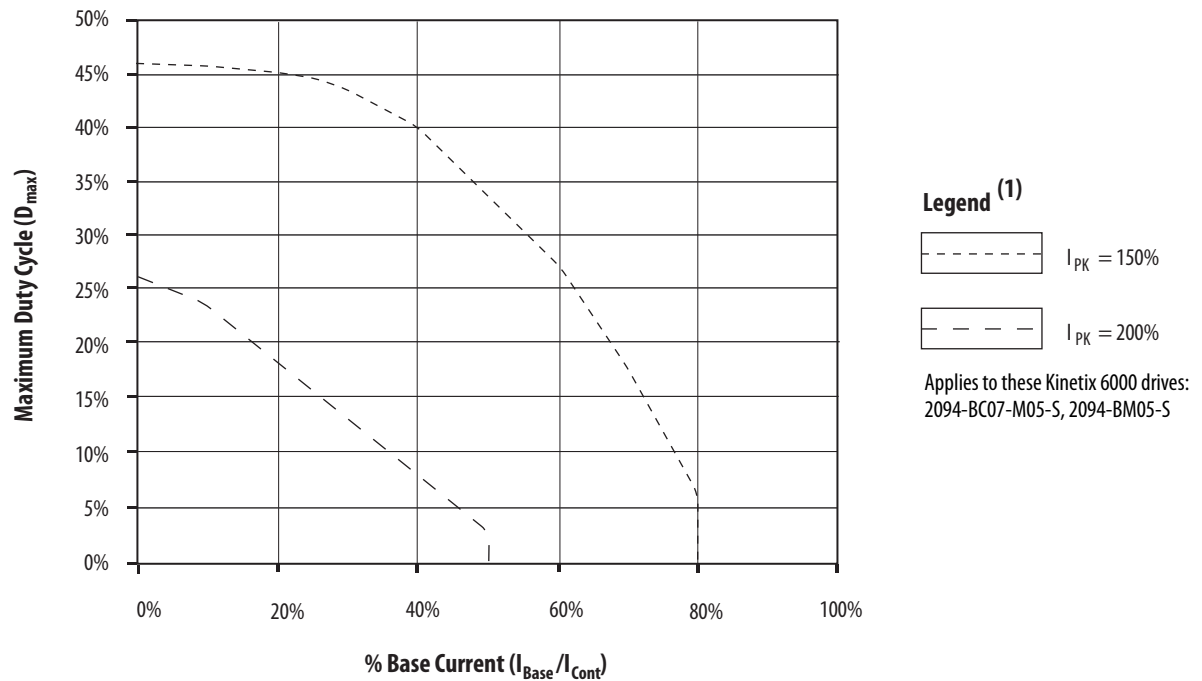

(1) Base current (I_{Base}) and peak current (I_{PK}) are a percentage of the continuous drive current rating (I_{Cont}).

Control Power

The IAM module requires AC input power for logic circuitry.

IMPORTANT The control power input requires an AC (EMC) line filter for CE certification. For wiring examples, refer to the Power Wiring Examples on [page 187](#).

IMPORTANT Control power isolation, via a step-down transformer, is required for all 460V applications. Source the 2094-ACxx-Mxx-x (230V) IAM module control power from the three-phase input power (line-to-line). Supplying control power from any other source requires an isolation transformer. Do not ground the transformer secondary to avoid ground fault conflicts with IAM module.

The National Electrical Code and local electrical codes take precedence over the values and methods provided. Implementation of these codes is the responsibility of the machine builder.

Table 49 - Control Power Input Power Specifications

Attribute	Value
Input voltage	95...264V AC rms, single-phase
Input power frequency	47...63 Hz
Control power AC input current Nom @ 220/230V AC rms Nom @ 110/115V AC rms Max inrush (0-pk)	6 A 6 A 98 A ⁽¹⁾

(1) For eight axis systems with 230V AC control input voltage and 50 °C (122°F) ambient temperature the maximum inrush duration is less than 1/2 line cycle. Use this equation to calculate maximum inrush current for systems with different axis count and control input voltage.

$$I_{PK} = 0.043 \times (V_{IN}) + 6.72 \times (\# \text{ of axes}) + 0.000333 \times (V_{IN}^2) - 0.816 \times (\# \text{ of axes})^2 + 0.0358 \times (\# \text{ of axes} \times V_{IN})$$

Table 50 - Control Power Current Requirements

Modules on Power Rail	110/115V AC Input		220/230V AC Input	
	Input Current A	Input VA VA	Input Current A	Input VA VA
IAM module only	0.56	67	0.36	85
IAM and 1 AM module	0.99	119	0.64	153
IAM and 2 AM module	1.43	172	0.92	220
IAM and 3 AM module	1.87	224	1.20	287
IAM and 4 AM module	2.31	277	1.48	354
IAM and 5 AM module	2.74	329	1.75	421
IAM and 6 AM module	3.18	382	2.03	488
IAM and 7 AM module	3.62	434	2.31	555
IDM power interface module (IPIM)	For specifications and an example for calculating the IPIM module current requirements, refer to the Kinetix 6000M Integrated Drive-Motor User Manual, publication 2094-UM003 .			

For Kinetix 6000M systems, calculate the sum of the control power current requirements for each IPIM module on the power rail and add that value with the appropriate value from [Table 50](#) for the number of axes on the power rail.

Feedback Specifications

The IAM and AM modules can accept motor and auxiliary feedback signals from these types of encoders:

- Stegmann Hiperface
- TTL or Sine/Cosine with index pulse and Hall commutation
- Resolver Transmitter TR = 0.25 (motor feedback only)

Motor feedback from Heidenhain EnDat high-resolution encoders is also accepted, but only when using drive firmware revision 1.116 and the 2090-K6CK-KENDAT low-profile feedback module for EnDat to Hiperface conversion.

Absolute Position Feature

The drive's absolute position feature tracks the position of the motor, within the multi-turn retention limits, while the drive is powered off. The absolute position feature is available with only these multi-turn encoders.

Table 51 - Absolute Position Designator Examples

Encoder Type	Motor Cat. No. Designator	Motor Cat. No. Example
Stegmann Hiperface	-M	MPL-B310P-M
	-V	MPL-B230P-V
Heidenhain EnDat	-7	RDB-B21519-7

Figure 37 - Absolute Position Retention Limit

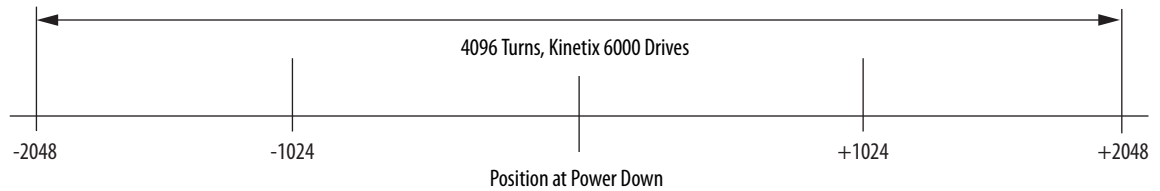

Motor Feedback Specifications

AM, BM, and IM input encoder signals are filtered by using analog and digital filtering. The inputs also include illegal state change detection.

Figure 38 - AM, BM, and IM Motor Encoder Input Circuits

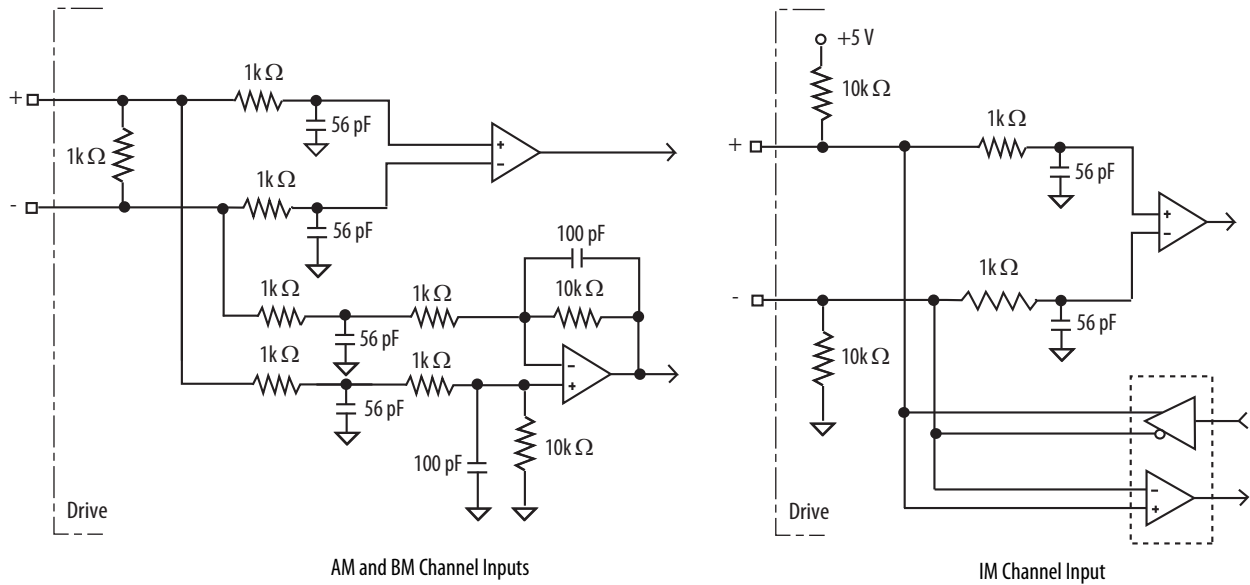

Table 52 - Motor Encoder Feedback Specifications

Attribute	Value
Encoder types	Incremental, A quad B, sine/cosine, intelligent, resolver, and absolute
Maximum input frequency	500 kHz (TTL input) per channel
	250 kHz (sine/cosine input)
Commutation feedback	Hall sensor

Table 53 - AM, BM, and IM Input Specifications for TTL Encoders

Parameter	Description	Min	Max
AM, BM, and IM On-state input voltage	Input voltage difference between the plus (+) input and the minus (-) input that is detected as an on-state.	+1.0V	+7.0V
AM, BM, and IM Off-state input voltage	Input voltage difference between the plus (+) input and the minus (-) input that is detected as an off-state.	-1.0V	-7.0V
Common mode input voltage	Potential difference between any encoder signal and logic ground.	-7.0V	+12.0V
DC current draw	Current draw into the + or - input.	-30 mA	30 mA
AM, BM input signal frequency	Frequency of the AM or BM signal inputs. The count frequency is 4 times this frequency, because the circuitry counts all four transitions.	–	500 kHz
IM pulse width	Pulse width of the index input signal. Because the index is active for a percentage of a revolution, the speed determines the pulse width.	125 nS	–
AM, BM phase error 2.5 MHz line frequency	Amount that the phase relationship between the AM and BM inputs can deviate from the nominal 90°.	-22.5°	+22.5°
AM, BM phase error 1 MHz line frequency	Amount that the phase relationship between the AM and BM inputs can deviate from the nominal 90°.	-45°	+45°

Table 54 - AM, BM, and IM Input Specifications for Sine/Cosine Encoders

Parameter	Description	Min	Max
Sine/cosine input signal frequency	Frequency of the Sine or Cosine signal inputs.	–	250 kHz
Sine/cosine input voltage	Peak-to-peak input voltages of the Sine or Cosine inputs.	0.8V (p-p)	1.2V (p-p)

Table 55 - Specifications for Heidenhain EnDat Encoders

Command Set	Order Designation	Description
EnDat 2.2	EnDat 01	1V p-p Sin/Cos, <2 MHz clock frequency

Feedback Power Supply Specifications

The IAM and AM power circuit board generates +5V and +9V DC for motor and auxiliary feedback power. Short circuit protection and separate common mode filtering for each channel is included.

Supply	Reference	Voltage			Current mA	
		Min	Nominal	Max	Min	Max
+5V DC	EPWR_5V	4.9	5.25	5.4	0	400
+9V DC	EPWR_9V	8.3	9.1	9.9	0	275

Auxiliary Position Feedback Encoders

Allen-Bradley Bulletin 842HR, 844D, 845H, and 845T encoders are the preferred encoders for auxiliary feedback connections.

Cat. No.	Description
842HR-MJDZ115FWYD (multi-turn) 842HR-SJDZ115FWYD (single-turn)	Size 25, sine/cosine, square flange, 3/8 in. shaft, 5V or 9V DC, digital RS-485 interface, M23 17-pin connector
844D-B5CC1FW	Size 20, incremental, square flange, 3/8 in. shaft, 5V DC, 5V DLD output, radial connector
844D-B5CC1CS	
844D-B5CC1DR	
845H-SJDN14FWY2	Size 25, incremental, square flange, 3/8 in. shaft, 5V DC, 5V DLD output, radial connector
845H-SJDN14CSY2	
845H-SJDN14DRY2	
845T-DN13EFW	HS35, hollow shaft incremental, 5/8 in. shaft, tether 3/8 in. bolt on, 5V DC, 5V DLD output, 10 pin connector
845T-DN13ECS	

Refer to the Kinetix Motion Accessories Technical Data, publication [GMC-TD004](#), for more information on these Allen-Bradley encoders.

Connecting the Kinetix 6000 Drive System

This chapter provides procedures for wiring your Kinetix 6000 system components and making cable connections.

Topic	Page
Basic Wiring Requirements	81
Determine the Input Power Configuration	83
Setting the Ground Jumper in Ungrounded Power Configurations	87
Grounding the Kinetix 6000 Drive System	93
Power Wiring Requirements	95
Power Wiring Guidelines	97
Wiring the IAM/AM Module Connectors	98
Apply the Motor Cable Shield Clamp	114
Feedback and I/O Cable Connections	115
Wiring the Feedback and I/O Connectors	120
External Shunt Module Connections	125
IPI Module Connections	126
RBM Module Connections	127
Sercos Fiber-optic Cable Connections	128
Kinetix 6000M Integrated Drive-Motor Sercos Connections	131
Ethernet Cable Connections	132

Basic Wiring Requirements

This section contains basic wiring information for the Kinetix 6000 drive modules.



ATTENTION: Plan the installation of your system so that you can perform all cutting, drilling, tapping, and welding with the system removed from the enclosure. Because the system is of the open type construction, be careful to keep any metal debris from falling into it. Metal debris or other foreign matter can become lodged in the circuitry, which can result in damage to components.



SHOCK HAZARD: To avoid hazard of electrical shock, perform all mounting and wiring of the Bulletin 2094 power rail and drive modules prior to applying power. Once power is applied, connector terminals can have voltage present even when not in use.

IMPORTANT This section contains common PWM servo system wiring configurations, size, and practices that can be used in a majority of applications. National Electrical Code, local electrical codes, special operating temperatures, duty cycles, or system configurations take precedence over the values and methods provided.

Building Your Own Cables

IMPORTANT Factory-made cables are designed to minimize EMI and are recommended over hand-built cables to optimize system performance.

Building your own cables is not an option for the hybrid and network cables used in Kinetix 6000M integrated drive-motor systems.

Follow these guidelines when building cables for compatible motors and actuators:

- Connect the cable shield to the connector shells on both ends of the cable with a complete 360° connection.
- Use twisted pair cable whenever possible. Twist differential signals with each other and twist single-ended signals with the appropriate ground return.

Refer to the Kinetix Motion Accessories Technical Data, publication [GMC-TD004](#), for low-profile connector kit, drive-end (mating) connector kit, and motor-end connector kit catalog numbers.

Routing the Power and Signal Cables

Be aware that when you route power and signal wiring on a machine or system, radiated noise from nearby relays, transformers, and other electronic drives can be induced into motor or encoder feedback signals, input/output communication, or other sensitive low voltage signals. This can cause system faults and communication anomalies.

Refer to Electrical Noise Reduction on [page 34](#) for examples of routing high and low voltage cables in wireways. Refer to the System Design for Control of Electrical Noise Reference Manual, publication [GMC-RM001](#), for more information.

Determine the Input Power Configuration

Before wiring input power to your Kinetix 6000 system, you must determine the type of input power you are connecting to. The IAM module is designed to operate in both grounded and ungrounded environments.



ATTENTION: When using a LIM module with your IAM module, the VAC LINE input power must come from a grounded configuration (refer to [Figure 39](#)). When not using a LIM module with your IAM module, ungrounded configurations are permitted, but you must set the jumper to the ungrounded position for proper drive operation. Refer to Setting the Ground Jumper in Ungrounded Power Configurations on [page 87](#) for more information.

Grounded Power Configurations

The grounded (WYE) power configuration lets you ground your three-phase power at a neutral point. This type of grounded power configuration is preferred.

Figure 39 - Grounded Power Configuration (WYE Secondary)

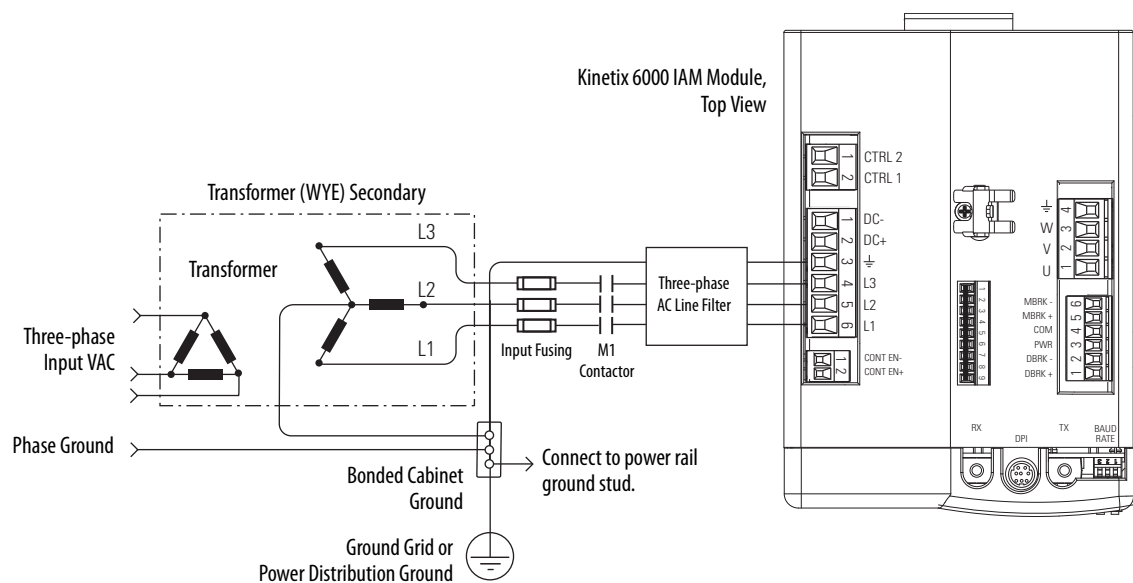

Refer to [Power Wiring Examples](#) beginning on [page 187](#) for input power interconnect diagrams with and without the LIM module.

Figure 40 - Grounded (B-Phase) Power Configuration (Delta Secondary)

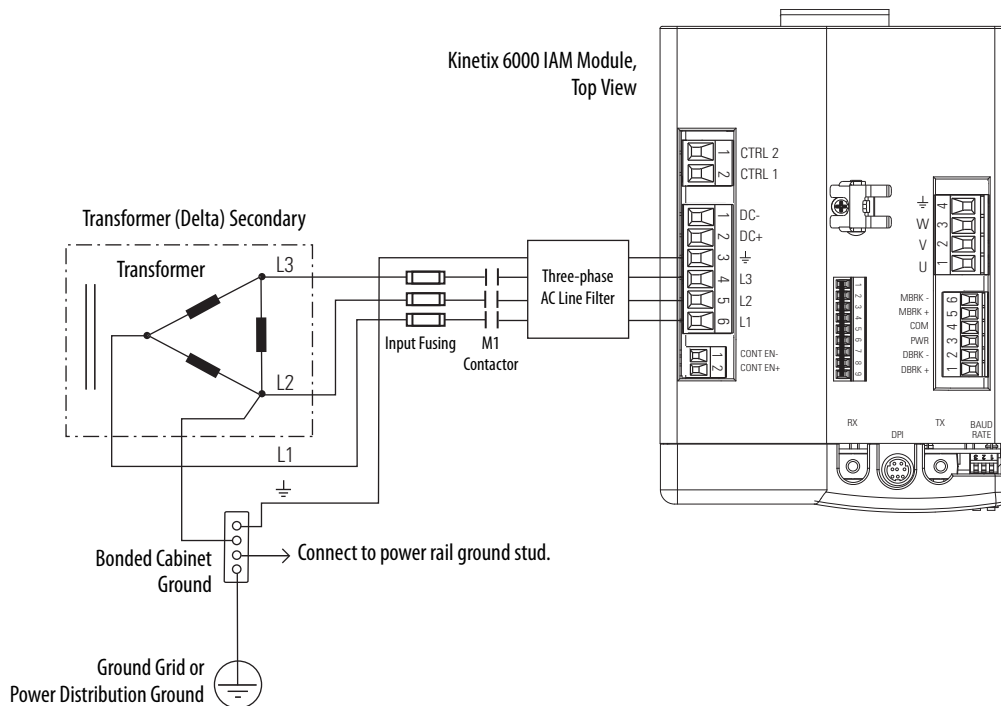

The IAM module has a factory-installed ground jumper configured for grounded power distribution.

IMPORTANT If you determine that you have grounded power distribution in your plant, you do not need to modify your IAM module.

Refer to Appendix A on [page 187](#), for input-power interconnect diagrams with and without the LIM module.

Ungrounded and High-impedance Grounded Power Configurations

Ungrounded and high-impedance grounded power configurations are allowed, but you must jumper across a 120 k Ω resistor (internal to the IAM module). The ungrounded power configuration (shown below) does not provide a neutral ground point. The IAM module has a ground jumper set for grounded power distribution (default configuration).

IMPORTANT If you determine that you have ungrounded or high-impedance grounded power distribution in your facility, you need to move the default jumper (configured for grounded power) to the ungrounded power position inside the IAM module.

Refer to [Setting the Ground Jumper in Ungrounded Power Configurations on page 87](#) for more information.

Figure 41 - Ungrounded Power Configuration

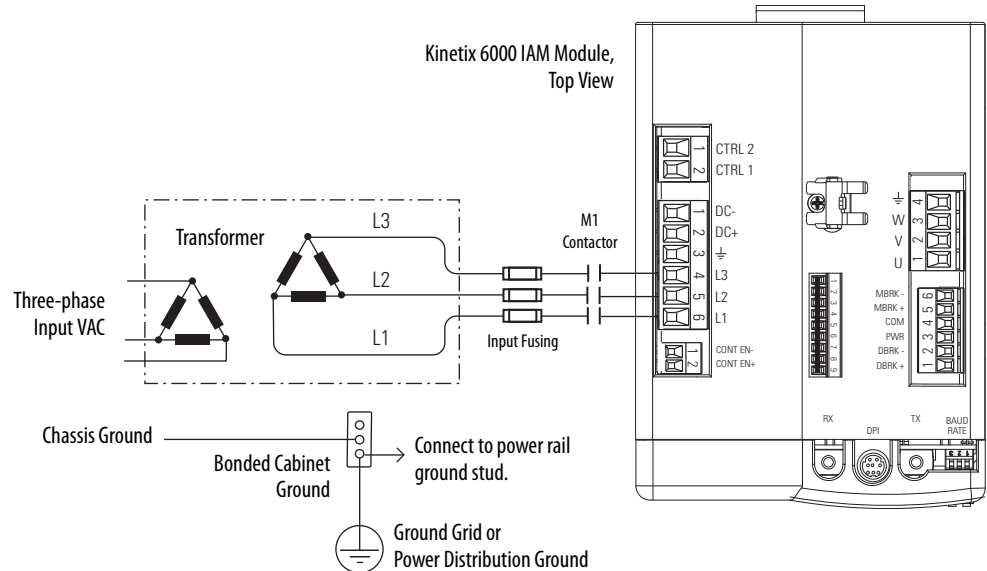

ATTENTION: Ungrounded systems do not reference each phase potential to a power distribution ground. This can result in an unknown potential to earth ground.

Refer to Appendix A on [page 187](#), for input-power interconnect diagrams with and without the LIM module.

DC Common Bus Configurations

When the IAM module is used in a DC common-bus configuration, the IAM module is known as a leader IAM or follower IAM module. The IAM (non-common bus) and leader IAM module have identical three-phase input power connections. The leader IAM module is responsible for discharging the DC bus, and for providing common-bus follower drives with DC bus pre-charge, bus regulation, phase-loss detection, and ground fault detection. Follower IAM modules do not have three-phase input power connections, but have DC bus connections from a leader IAM module.

Table 56 - IAM Module Terminology and Use

This Module	Is Wired	And is
IAM	With three-phase input power.	Not wired in Common-bus mode.
Leader IAM	With three-phase input power, but has DC common-bus connections to a follower IAM module.	Wired in Common-bus mode.
Follower IAM	Without three-phase input power, but has DC common-bus connections from a leader IAM module.	Wired in Common-bus mode and configured by using the Logix Designer application.

IMPORTANT Use Kinetix 6000 drive firmware revision 1.85 and the Logix Designer Application or RSLogix 5000 software, version 15 or later, for common-bus power configurations.

The Kinetix 6000 leader IAM module can operate with non-Kinetix 6000 follower drives, as can the Kinetix 6000 follower IAM module operate with non-Kinetix 6000 common-bus leader drives. However, non-Kinetix 6000 leader and follower drives must meet the same functional requirements as the Kinetix 6000 leader and follower IAM modules.

IMPORTANT Any non-Kinetix 6000 common-bus leader IAM module that does not provide pre-charge is required to add an additional external pre-charge circuit before connecting to any Kinetix 6000 common-bus follower IAM module.

Figure 42 - Typical DC Common-bus Configuration

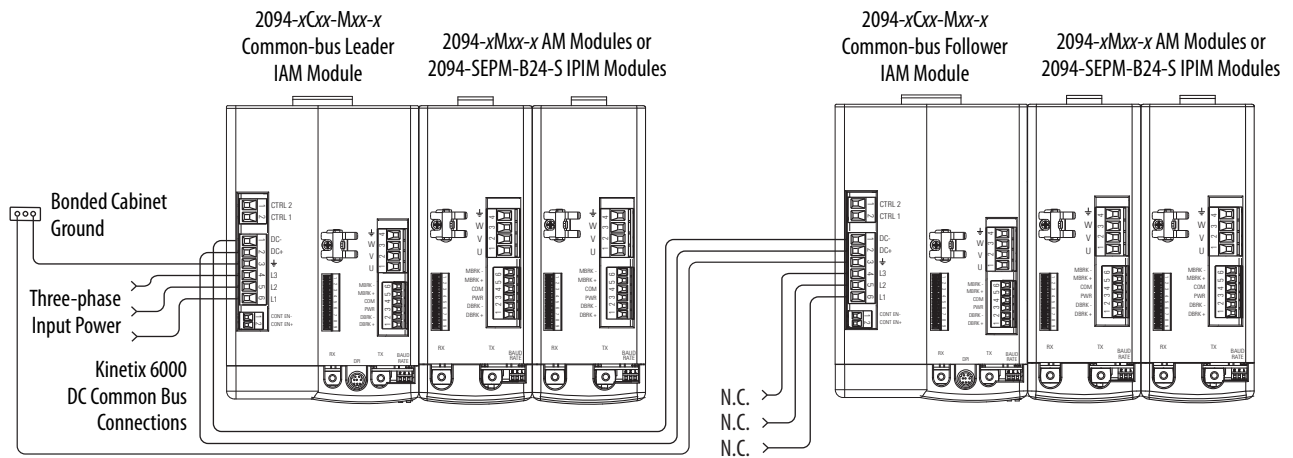

Common Bus Fusing Requirements

When using a Kinetix 6000 leader IAM module, DC-bus fuses are required only when wiring to more than one Kinetix 6000 follower IAM module. When wiring multiple follower IAM modules, terminal blocks are required to extend the DC common-bus power to additional drives. Install fuses in both lines of the DC bus between the DC bus terminal block and each follower IAM module. Base these fuse ratings on the DC input current of each follower IAM module.

When using a non-Kinetix 6000 common-bus leader drive, DC bus fuses are required in both lines of the DC bus, between the common-bus leader drive and follower IAM module. Base these fuse ratings on the common-bus leader drive DC output current. When using more than one follower IAM module, install fuses in both lines of the DC bus between the non-Kinetix 6000 common-bus leader and the terminal block as well as between the DC bus terminal block and each follower IAM module.

Refer to Circuit Breaker/Fuse Options on [page 28](#), for recommended circuit breaker/fuse sizes. Refer to DC Common Bus Wiring Examples on [page 191](#) for interconnect diagrams.

Setting the Ground Jumper in Ungrounded Power Configurations

Setting the ground jumper is necessary only when using an ungrounded or high-impedance grounded power configuration. Setting the jumper involves removing the IAM module from the power rail, opening the IAM module, and moving the jumper.

IMPORTANT If you have grounded power distribution, you do not need to set the ground jumper. Go to Grounding the Kinetix 6000 Drive System on [page 93](#).

Setting the ground jumper is best done when the IAM module is removed from the power rail and placed face-up on a solid surface equipped as a grounded static-safe workstation.



ATTENTION: To avoid personal injury and/or damage to equipment, remove the IAM module from the power rail before setting the ground jumper.

By setting the ground jumper for ungrounded power configurations, you no longer maintain line-to-neutral voltage protection.

To remove the IAM module from the power rail, refer to Remove Kinetix 6000 Drive Modules on [page 180](#).



ATTENTION: This drive contains electrostatic discharge (ESD) sensitive parts and assemblies. You are required to follow static-control precautions when you install, test, service, or repair this assembly. If you do not follow ESD control procedures, components can be damaged. If you are not familiar with static control procedures, refer to Guarding Against Electrostatic Damage, publication [8000-4.5.2](#), or any other applicable ESD awareness handbook.

When using ungrounded input power in common-bus configurations, use this table to determine where to set the ground jumper.

Table 57 - Ground Jumper to Set

Leader Drive	Follower Drive	Set the Jumper in This Drive
Kinetix 6000 IAM module	Kinetix 6000 IAM module	Leader drive
Kinetix 6000 IAM module	Non-Kinetix 6000 drive	Leader drive
Non-Kinetix 6000 drive	Kinetix 6000 IAM module	Follower drive (if no setting exists in the leader drive)

Set the Ground Jumper

Follow these steps to set the ground jumper for ungrounded power.

1. Remove the top and bottom front-panel screws.

Refer to the figures beginning on [page 90](#) (230V IAM module) or [page 91](#) (460V IAM module) for an illustration of your actual hardware.

2. Swing the front panel open to the right, as shown, and locate the ground jumper.

IMPORTANT Do not attempt to remove the front panel from the IAM module. The front panel status indicators and switches are also connected to the IAM module with a ribbon cable. The ribbon cable acts like a hinge and lets you swing the front panel open to access the ground jumper.

3. Move the ground jumper.

IAM Module (series A)	Configuration	
	Grounded (default)	Ungrounded
2094-ACxx-Mxx-x (230V) ⁽¹⁾	P15 and P16	P15 and P17
2094-BC01-MP5-x (460V)	P13 and P14	P13 and P12
2094-BC01-M01-x (460V)		
2094-BC02-M02-x (460V)		
2094-BC04-M03-x (460V)	P14 and P13	P14 and P12
2094-BC07-M05-x (460V)		

(1) Applies to series A and C (230V) drives.

IAM Module (series B and C)	Configuration	
	Grounded (default)	Ungrounded
2094-BC01-MP5-S (460V)	P16 and P17	P18 and P19
2094-BC01-M01-S (460V)		
2094-BC02-M02-S (460V)		
2094-BC04-M03-S (460V)		
2094-BC07-M05-S (460V)		

4. Replace the IAM module front panel and two screws.

Apply 1.6 N•m (14 lb•in) torque.

5. Mount the IAM module back on the power rail.

Refer to Replace Kinetix 6000 Drive Modules on [page 181](#).

Figure 43 - Setting the Ground Jumper (230V Series A and C IAM modules)

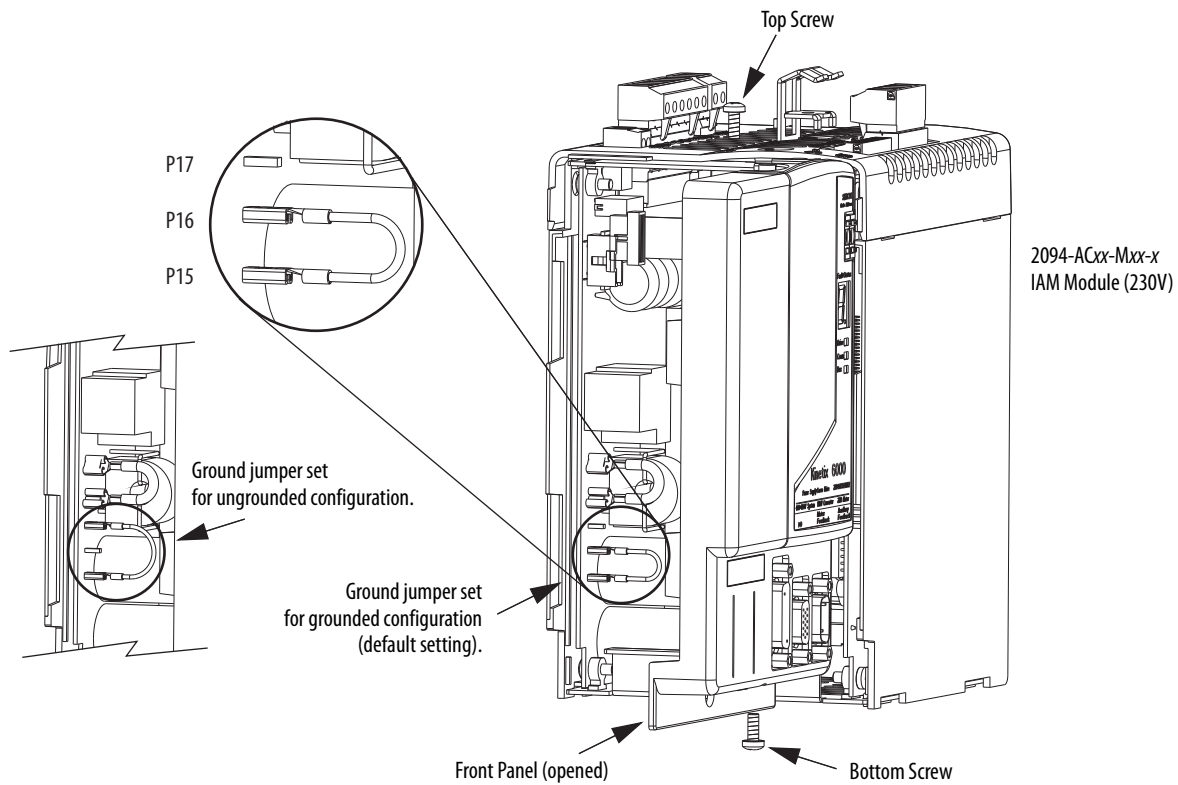

IMPORTANT Use the default jumper setting or remove the jumper entirely for grounded power configurations. Move the jumper, as shown above, for ungrounded power.

Figure 44 - Setting the Ground Jumper (460V Series A IAM modules)

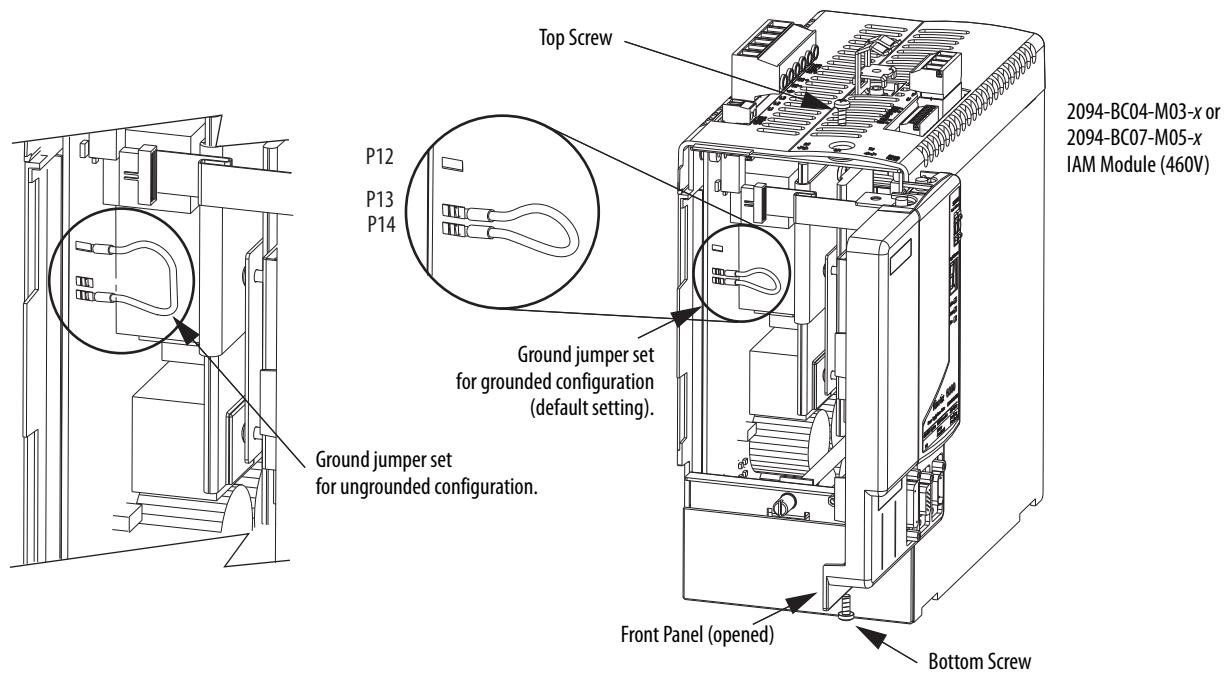
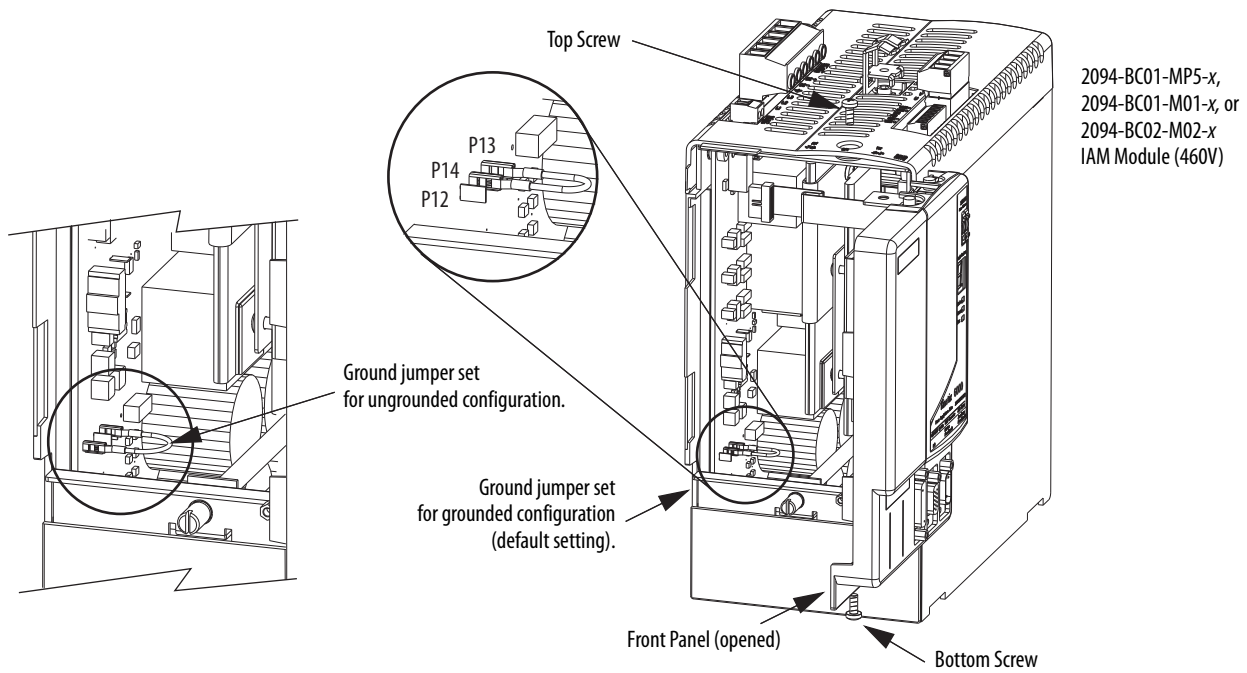

IMPORTANT Use the default jumper setting or remove the jumper entirely for grounded power configurations. Move the jumper, as shown above, for ungrounded power.

Figure 45 - Setting the Ground Jumper (460V Series B and C IAM modules)

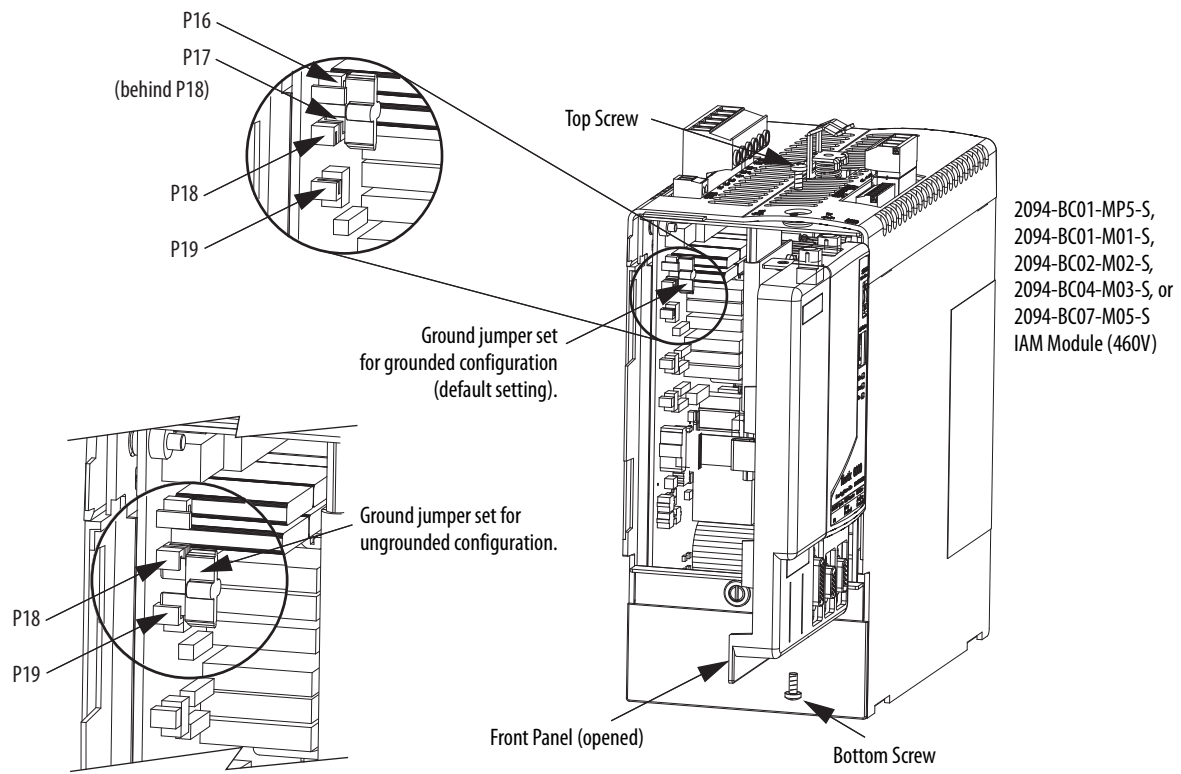

Grounding the Kinetix 6000 Drive System

All equipment and components of a machine or process system must have a common earth ground point connected to chassis. A grounded system provides a ground path for short circuit protection. Grounding your modules and panels minimize shock hazard to personnel and damage to equipment caused by short circuits, transient overvoltages, and accidental connection of energized conductors to the equipment chassis.



ATTENTION: The National Electrical Code contains grounding requirements, conventions, and definitions. Follow all applicable local codes and regulations to safely ground your system.

For CE grounding requirements, refer to Agency Compliance on [page 24](#).

Ground the Power Rail to the System Subpanel

The 2094-PR x and 2094-PRS x power rail ships with a braided ground strap, 100 mm (3.9 in.), that connects to the bonded cabinet ground bus. Connect the other end to either the power rail ground stud or mounting bracket ground stud, if mounting brackets are used.

Figure 46 - Connecting the Braided Ground Strap Examples

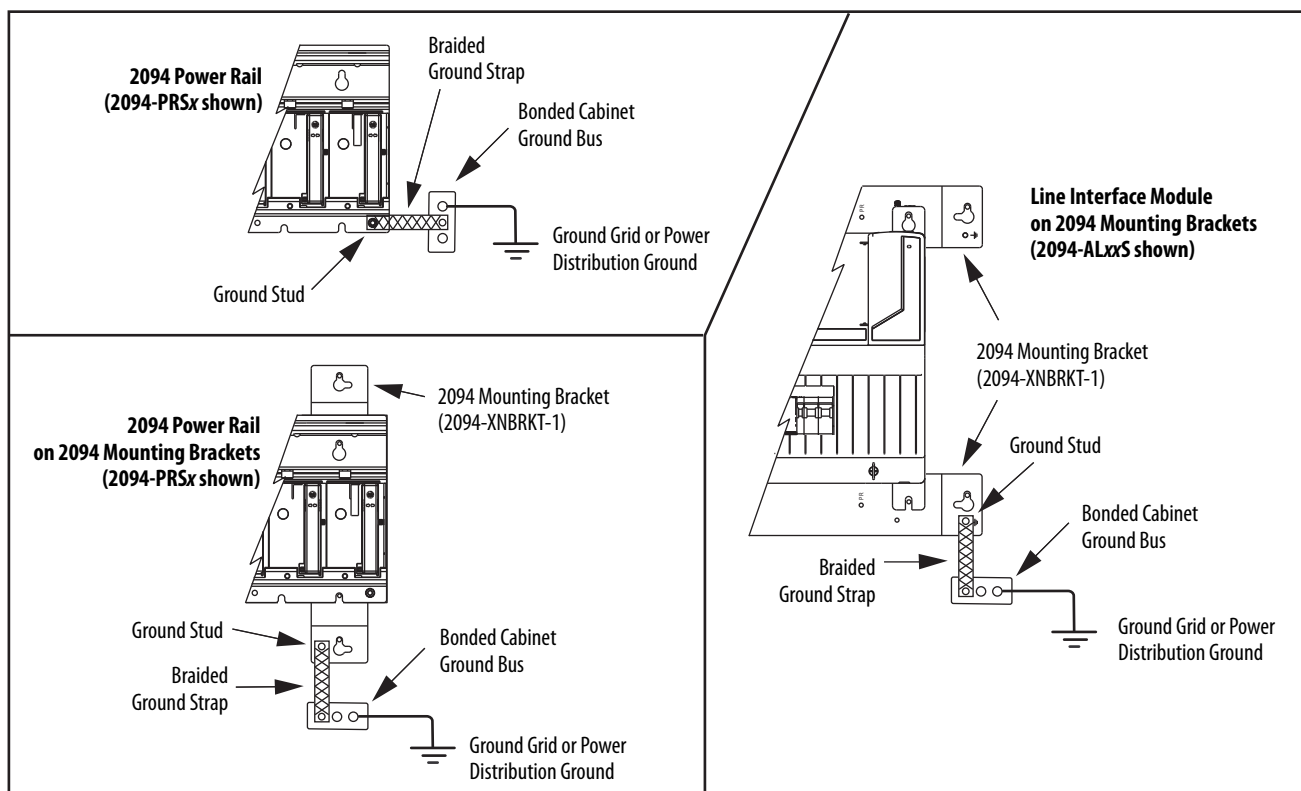

For power rail dimensions, refer to the Kinetix 6000 Power Rail Installation Instructions, publication [2094-IN003](#).

For mounting bracket dimensions, refer to the 2094 Mounting Brackets Installation Instructions, publication [2094-IN008](#).

IMPORTANT When 2094 mounting brackets are used to mount the power rail or LIM module over the AC line filter, the braided ground strap must be removed from the power rail and attached to a mounting bracket ground stud.

Ground Multiple Subpanels

In this figure, the chassis ground is extended to multiple subpanels.

Figure 47 - Subpanels Connected to a Single Ground Point

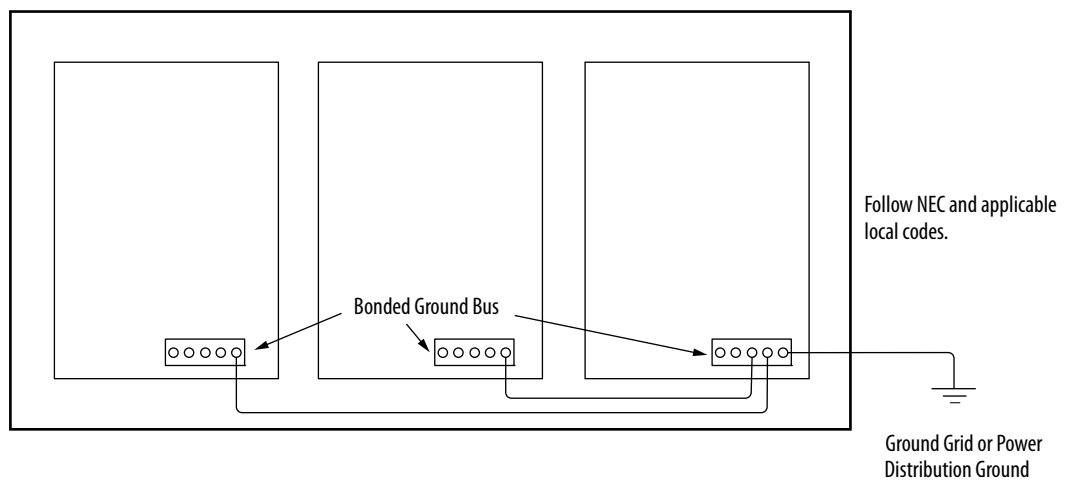

High-frequency (HF) bonding is not illustrated. For HF bonding information, refer to Bonding Multiple Subpanels on [page 36](#).

Power Wiring Requirements

Wire must be copper with 75 °C (167 °F) minimum rating. Phasing of main AC power is arbitrary and earth ground connection is required for safe and proper operation.

For IPIM module power wiring requirements, refer to the Kinetix 6000M Integrated Drive-Motor System User Manual, publication [2094-UM003](#).

Refer to Power Wiring Examples on [page 187](#) for interconnect diagrams.

IMPORTANT The National Electrical Code and local electrical codes take precedence over the values and methods provided.

Table 58 - IAM Power Wiring Requirements

Kinetix 6000 Drive Cat. No.	Description	Connects to Terminals		Recommended Wire Size mm ² (AWG)	Strip Length mm (in.)	Torque Value N·m (lb·in)
		Pin	Signal			
2094-AC05-Mxx-x	DC bus ⁽¹⁾ and VAC input power	IPD-1	DC-	6...2.5 (10...14)	10 (0.38)	0.5...0.6 (4.4...5.3)
2094-AC09-M02-x		IPD-2	DC+	6...4 (10...12)		
2094-AC16-M03-x		IPD-3	$\frac{\perp}{\perp}$	30...10 (3...8)	16 (0.63)	2.4...3.0 (21.6...26.5)
2094-AC32-M05-x		IPD-4	L3			
		IPD-5	L2			
		IPD-6	L1	30 (3)		
2094-BC01-Mxx-x	DC bus ⁽¹⁾ and VAC input power	IPD-1	DC-	10...2.5 (8...14)	10 (0.38)	1.2...1.5 (10.6...13.2)
2094-BC02-M02-x		IPD-2	DC+	10...6 (8...10)		
2094-BC04-M03-x		IPD-3	$\frac{\perp}{\perp}$	30 (3)	16 (0.63)	2.4...3.0 (21.6...26.5)
2094-BC07-M05-x		IPD-4	L3			
		IPD-5	L2			
		IPD-6	L1			
2094-xCxx-Mxx-x	Control input power	CPD-1	CTRL 2	4...2.5 (12...14)	10 (0.38)	0.5...0.6 (4.4...5.3)
		CPD-2	CTRL 1			
	Contactor Enable	CED-1	CONT EN-	4...2.5 (12...14) ⁽²⁾		0.5...0.6 (4.4...5.3)
		CED-2	CONT EN+			

(1) Keep DC common-bus connections (leader IAM to follower IAM module) as short as possible.

(2) The actual gauge of the contactor enable wiring depends on the system configuration. Consult your machine builder, the NEC, and applicable local codes.



ATTENTION: To avoid personal injury and/or equipment damage, make sure installation complies with specifications regarding wire types, conductor sizes, branch circuit protection, and disconnect devices. The National Electrical Code (NEC) and local codes outline provisions for safely installing electrical equipment.

ATTENTION: To avoid personal injury and/or equipment damage, make sure motor power connectors are used for connection purposes only. Do not use them to turn the unit on and off.

ATTENTION: To avoid personal injury and/or equipment damage, make sure shielded power cables are grounded to prevent potentially high voltages on the shield.

Table 59 - IAM/AM Power Wiring Requirements

Kinetix 6000 Drive Cat. No.	Description	Connects to Terminals		Recommended Wire Size mm ² (AWG)	Strip Length mm (in.)	Torque Value N·m (lb·in)
		Pin	Signal			
2094-AC05-Mxx-x, 2094-AC09-M02-x, 2094-BC01-Mxx-x, 2094-BC02-M02-x, 2094-AMP5-x, 2094-AM01-x, 2094-AM02-x, 2094-BMP5-x, 2094-BM01-x, 2094-BM02-x	Motor power	MP-4 MP-3 MP-2 MP-1	 W V U	Motor power cable depends on motor/drive combination. 6...1.5 (10...16)	10 (0.38)	0.5...0.6 (4.4...5.3)
2094-AC16-M03-x, 2094-AC32-M05-x, 2094-BC04-M03-x, 2094-AM03-x, 2094-AM05-x, 2094-BM03-x				10...1.5 (8...16)	10 (0.38)	1.2...1.5 (10.6...13.2)
2094-BC07-M05-x, 2094-BM05-x				30...2.5 (3...14)	16 (0.63)	2.4...3.0 (21.6...26.5)
IAM or AM (230 or 460V) 2094-xCxx-Mxx-x and 2094-xMxx-x	Brake power	BC-6 BC-5 BC-4 BC-3 BC-2 BC-1	MBRK- MBRK+ COM PWR DBRK- DBRK+	0.75 (18)	10 (0.38)	0.22...0.25 (1.9...2.2)
IAM or AM (230 or 460V) 2094-xCxx-Mxx-S and 2094-xMxx-S	Safe torque-off	STO-1 STO-2 STO-3 STO-4 STO-5 STO-6 STO-7 STO-8 STO-9	FDBK2+ FDBK2- FDBK1+ FDBK1- SAFETY ENABLE2+ SAFETY ENABLE- SAFETY ENABLE1+ 24V + 24V_COM	0.75 (18) (stranded wire with ferrule) 1.5 (16) (solid wire)	7.0 (0.275)	0.235 (2.0)

Table 60 - Shunt Module Power Wiring Requirements

Drive Module Cat. No.	Description	Connects to Terminals		Recommended Wire Size mm ² (AWG)	Torque Value N·m (lb·in)
		Pin	Signal		
2094-BSP2 Shunt module (200/400V-class)	1394-SRxxxx External passive shunt module	RC-1	DC+	10 (8) ⁽¹⁾	1.2...1.5 (10.6...13.2)
		RC-2	INT		
		RC-3	COL		
	Thermal switch	TS-1	TS1	0.75 (18)	0.22...0.25 (1.9...2.2)
TS-2		TS2			

(1) 105 °C (221 °F), 600V.

Power Wiring Guidelines

Use these guidelines as a reference when wiring the power connectors on your IAM and AM drive modules.

For IPIM module power wiring guidelines, refer to the Kinetix 6000M Integrated Drive-Motor System User Manual, publication [2094-UM003](#).

IMPORTANT For connector locations of the Kinetix 6000 drive modules, refer to 2094 IAM/AM Module Connector Data on [page 58](#).

When tightening screws to secure the wires, refer to the tables beginning on [page 95](#) for torque values.

When removing insulation from wires, refer to the tables beginning on [page 95](#) for strip lengths.

IMPORTANT To improve system performance, run wires and cables in the wireways as established in Establishing Noise Zones on [page 37](#).

Follow these steps when wiring the connectors on your IAM and AM drive modules.

1. Prepare the wires for attachment to each connector plug by removing insulation equal to the recommended strip length.

IMPORTANT Use caution not to nick, cut, or otherwise damage strands as you remove the insulation.

2. Route the cable/wires to your IAM and AM drive modules.
3. Insert wires into connector plugs.
Refer to connector pinout tables in [Chapter 4](#) or the interconnect diagrams in [Appendix A](#).
4. Tighten the connector screws.
5. Gently pull on each wire to make sure it does not come out of its terminal; reinsert and tighten any loose wires.
6. Insert the connector plug into the module connector.

Wiring the IAM/AM Module Connectors

This section provides examples and wiring tables to assist you in making connections to the IAM and AM modules.

Wire the Control Power (CPD) Connector

This example applies to any IAM, leader IAM, or follower IAM module.

Figure 48 - IAM Module (CPD connector)

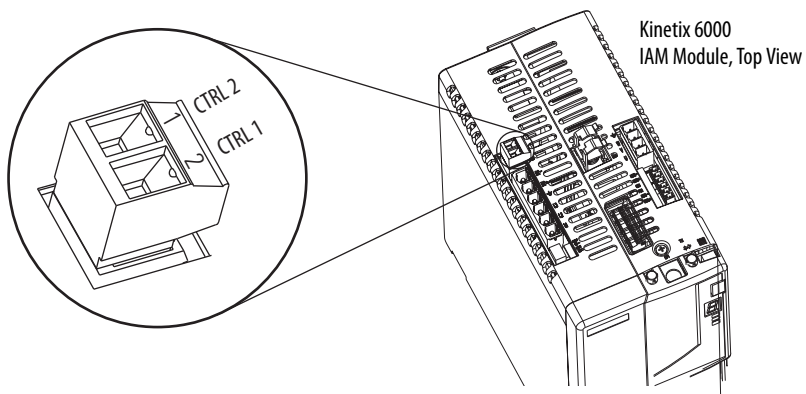

Table 61 - Control Power (CPD) Connector

CPL Connector (LIM module) or Other Single-phase Input				CPD Connector (IAM module)		Recommended Wire Size mm ² (AWG)	Strip Length mm (in.)	Torque Value N·m (lb·in)
2094-ALxxS, 2094-BLxxS, or 2094-XL75S-Cx LIM Module		2094-AL09 and 2094-BL02 LIM Module		CPD Pin	Signal			
CPL Pin	Signal	CPL Pin	Signal	CPD Pin	Signal			
1	CTRL 1	2	L1	1	CTRL 2	2.5 (14)	10 (0.38)	0.5...0.6 (4.4...5.3)
2	CTRL 2	1	L2/N	2	CTRL 1			

Wire the Input Power (IPD) Connector

This example applies to any IAM module or common-bus leader IAM module.



ATTENTION: Make sure the input power connections are correct when wiring the IPD connector plug and that the plug is fully engaged in the module connector. Incorrect wiring/polarity or loose wiring can cause explosion or damage to equipment.

Figure 49 - IAM Module (IPD connector)

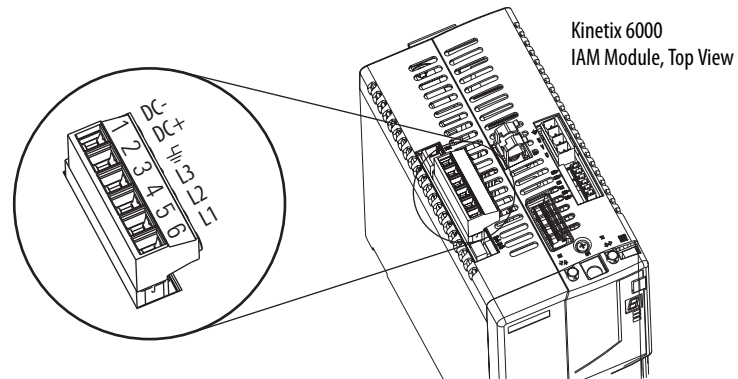

Table 62 - Input Power (IPD) Connections

OPL Connector (LIM module) or Other Three-phase Input				IPD Connector (IAM or leader IAM module)	
2094-AL09 LIM Module		2094-ALxxS, 2094-BLxxS, or 2094-XL75S-Cx LIM Modules			
OPL Pin	Signal	OPL Pin	Signal	IPD Pin	Signal
1	L1'	4	L1'	6	L1
2	L2'	3	L2'	5	L2
3	L3'	2	L3'	4	L3
4	\perp	1	\perp	3	\perp
N/A				2	DC+
				1	DC-

Table 63 - Termination Specifications

IAM Module Cat. No.	Input VAC	Recommended Wire Size mm ² (AWG)	Strip Length mm (in.)	Torque Value N·m (lb·in)
2094-AC05-Mxx-x	230V AC	2.5 (14)	10 (0.38)	0.5...0.6 (4.4...5.3)
2094-AC09-M02-x		4.0 (12)		
2094-AC16-M03-x		10 (8)	16 (0.63)	
2094-AC32-M05-x		30 (3)		
2094-BC01-Mxx-x 2094-BC02-M02-x	460V AC	2.5 (14)	10 (0.38)	1.2...1.5 (10.6...13.2)
2094-BC04-M03-x		6 (10)	16 (0.63)	2.4...3.0 (21.6...26.5)
2094-BC07-M05-x		30 (3)		

This example applies to a common-bus follower IAM module.



ATTENTION: Make sure the common-bus power connections are correct when wiring the IPD connector plug and that the plug is fully engaged in the module connector. Incorrect wiring/polarity or loose wiring can cause explosion or damage to equipment.

Figure 50 - IAM Module (IPD connector)

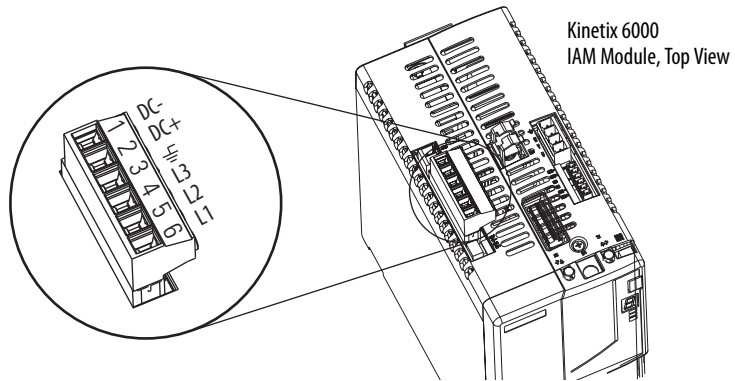

Table 64 - Input Power (IPD) Connections

IPD Connector (IAM or follower IAM module)	
IPD Pin	Signal
6	N.C.
5	N.C.
4	N.C.
3	⏏
2	DC+
1	DC-

IMPORTANT Do not connect three-phase input power to the common-bus follower IAM module.

Table 65 - Termination Specifications

IAM Module Cat. No.	Input VAC	Recommended Wire Size mm ² (AWG)	Strip Length mm (in.)	Torque Value N·m (lb·in)
2094-AC05-Mxx-x	230V AC	2.5 (14)	10 (0.38)	0.5...0.6 (4.4...5.3)
2094-AC09-M02-x		4.0 (12)		
2094-AC16-M03-x		10 (8)	16 (0.63)	2.4...3.0 (21.6...26.5)
2094-AC32-M05-x		30 (3)		
2094-BC01-Mxx-x 2094-BC02-M02-x	460V AC	2.5 (14)	10 (0.38)	1.2...1.5 (10.6...13.2)
2094-BC04-M03-x		6 (10)	16 (0.63)	2.4...3.0 (21.6...26.5)
2094-BC07-M05-x		30 (3)		

Wire the Contactor Enable (CED) Connector

This example applies to any IAM, common-bus leader IAM, or common-bus follower IAM module.

Figure 51 - IAM Module (CED connector)

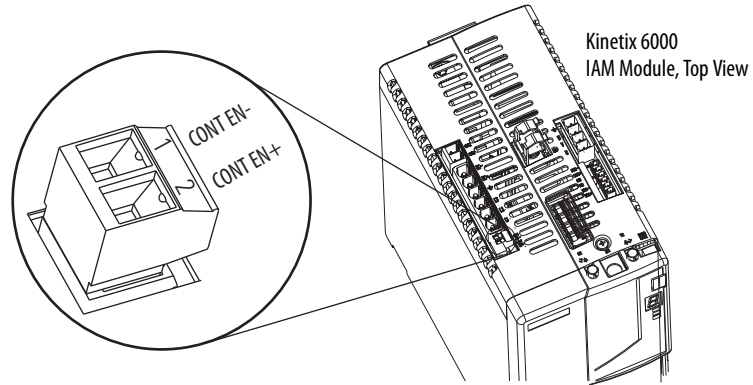

ATTENTION: Wiring the contactor enable relay is required. To avoid personal injury or damage to the drive, wire the contactor enable relay into your safety control string. Refer to Contactor Enable Relay on [page 70](#).

In common-bus configurations, the contactor enable (CED) connections for leader and follower drives must be wired in series to the control string.

For interconnect diagrams, refer to Interconnect Diagram Notes beginning on [page 186](#).

Table 66 - Contactor Enable (CED) Connector

LIM Module I/O (IOL) Connector or Other Control String		CED Pin	Signal	Recommended Wire Size mm ² (AWG)	Strip Length mm (in.)	Torque Value N·m (lb·in)
2094-ALxxS, 2094-BLxxS, or 2094-XL75S-Cx LIM Modules	2094-AL09 and 2094-BL02 LIM Modules					
IO_COM1	IO_COM	1	CONT EN-	2.5 (14) ⁽¹⁾	10 (0.38)	0.5...0.6 (4.4...5.3)
COIL_E2	COIL_A2	2	CONT EN+			

(1) The actual gauge of the contactor enable wiring depends on the system configuration. Consult your machine builder, the NEC, and applicable local codes.

Wiring the Safe Torque-off (STO) Connector

This example applies to any IAM or AM module equipped with the torque-off (STO) connector.

Figure 52 - IAM/AM Module (STO connector)

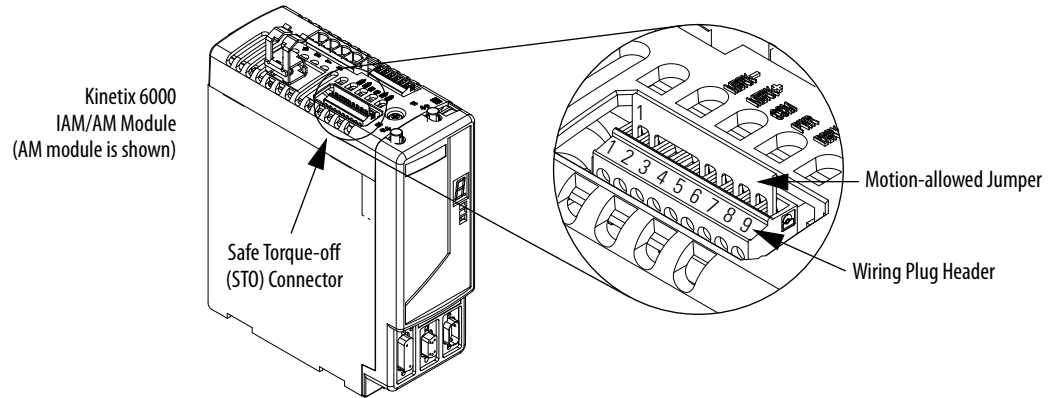

Each IAM and AM module ships with the (9-pin) wiring-plug header and motion-allowed jumper installed in the safe torque-off connector. With the motion-allowed jumper installed, the safe torque-off feature is not used.

Pinouts for the torque-off (STO) connector are shown on [page 60](#).

IMPORTANT Pins STO-8 and STO-9 (24V+) are used by only the motion-allowed jumper. When wiring to the wiring-plug header, the 24V supply must come from an external source.

Table 67 - Safe Torque-off (STO) Connector

STO Pin	Signal	Recommended Wire Size mm ² (AWG)	Strip Length mm (in.)	Torque Value N·m (lb·in)
1	FDBK2+	0.75 (18) (stranded wire with ferrule)	7.0 (0.275)	0.235 (2.0)
2	FDBK2-			
3	FDBK1+			
4	FDBK1-			
5	SAFETY ENABLE2+	1.5 (16) (solid wire)		
6	SAFETY ENABLE-			
7	SAFETY ENABLE1+			
8	24V +			
9	24V_COM			

To wire the safe torque-off connector in single axis or multi-axis configurations, refer to the Kinetix Safe Torque-off Feature Safety Reference Manual, publication [GMC-RM002](#).

Wire the Motor Power (MP) Connector

Connections to the motor power (MP) connector include rotary motors, linear motors, and motor driven actuators.



ATTENTION: Make sure the motor power connections are correct when wiring the MP connector plug and that the plug is fully engaged in the module connector. Incorrect wiring/polarity or loose wiring can cause explosion or damage to equipment.

This example applies to AM modules and the inverter section of IAM modules.

Figure 53 - IAM/AM Module (MP connector)

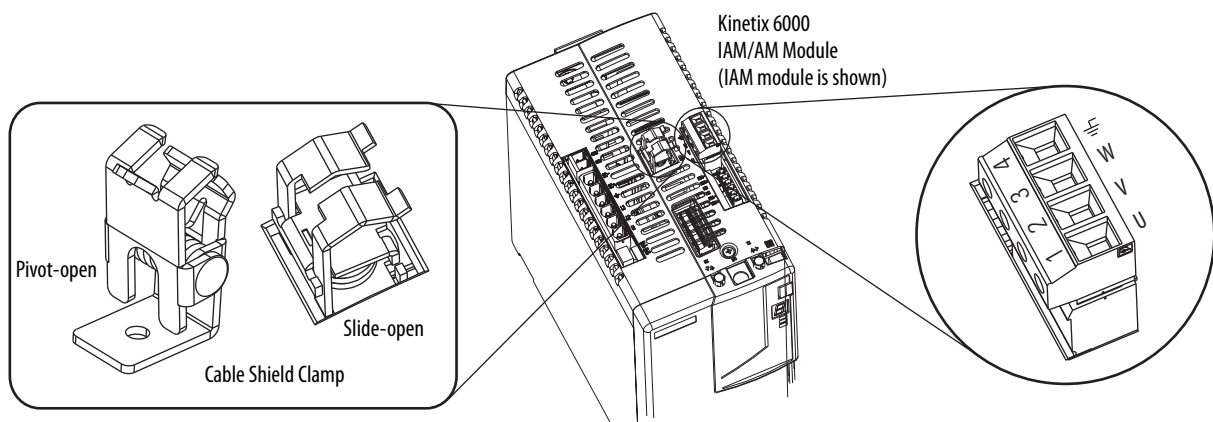

Cable Shield Terminations

Factory-supplied Bulletin 2090 motor power cables for motors and actuators are shielded, and the braided cable shield must terminate at the drive during installation. A small portion of the cable jacket must be removed to expose the shield braid. The exposed area must be clamped (with the clamp provided) on top of the IAM or AM modules and the power wires terminated in the motor power (MP) connector plug.



SHOCK HAZARD: To avoid hazard of electrical shock, make sure shielded power cables are grounded at a minimum of one point for safety.

IMPORTANT For TL-Series motors, also connect the 152 mm (6.0 in.) termination wire to the closest earth ground.
Refer to Pigtail Terminations on [page 104](#) for more information.

Pigtail Terminations

TL-Series motors have a short pigtail cable that connects to the motor, but is not shielded. The preferred method for grounding the TL-Series power cable on the motor side is to expose a section of the cable shield and clamp it directly to the machine frame. The motor power cable also has a 150 mm (6.0 in.) shield termination wire with a ring lug that connects to the closest earth ground. Use this method in addition to the cable clamp. The termination wire can be extended to the full length of the motor pigtail if necessary, but it is best to connect the supplied wire directly to ground without lengthening.

Figure 54 - Pigtail Terminations

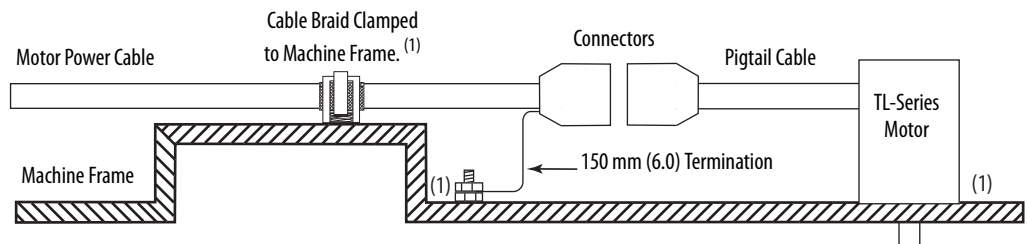

- (1) Remove paint from machine frame to be sure of proper HF-bond between machine frame and motor case, shield clamp, and ground stud.

MP-Series (Bulletin MPL) Motor Connectors

Bulletin MPL motors equipped with circular DIN connectors (specified by 4 or 7 in the catalog number) are not compatible with cables designed for motors equipped with bayonet connectors (specified by 2 in the catalog number). The motors with bayonet connectors are being discontinued.

Table 68 - MP-Series (Bulletin MPL) Motor Catalog Numbers

Motor Cat. No. /SpeedTec DIN Connectors	Motor Cat. No. /Threaded DIN Connectors	Motor Cat. No. /Bayonet Connectors
MPL-A/B15xxx-xx7xAA MPL-A/B2xxx-xx7xAA	MPL-A/B15xxx-xx4xAA MPL-A/B2xxx-xx4xAA	N/A
MPL-A/B3xxx-xx7xAA, MPL-A/B4xxx-xx7xAA, MPL-A/B45xxx-xx7xAA, MPL-A/B5xxx-xx7xAA	N/A	MPL-A/B3xxx-xx2xAA, MPL-A/B4xxx-xx2xAA, MPL-A/B45xxx-xx2xAA, MPL-A/B5xxx-xx2xAA
MPL-B6xxx-xx7xAA, MPL-B8xxx-xx7xAA, MPL-B9xxx-xx7xAA	N/A	MPL-B6xxx-xx2xAA, MPL-B8xxx-xx2xAA, MPL-B9xxx-xx2xAA

Bayonet connectors can be mounted facing the motor shaft or end plate and provide a separate connector for power, feedback, and brake connections. Circular DIN connectors rotate up to 180° and combine power and brake wires in the same connector, eliminating the brake connector.

Figure 55 - Bayonet and Circular DIN Motor Connectors

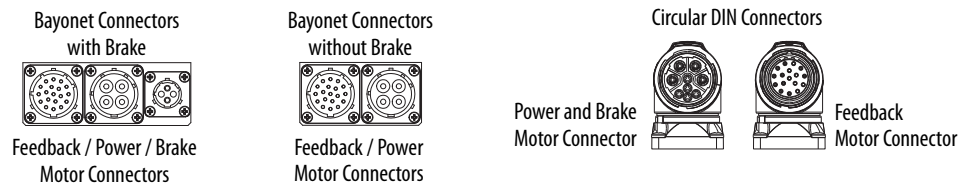

Motor Power Wiring Examples

The procedure for wiring motor power varies slightly, depending on the motor family. The cables compatible with your motor or actuator depend on the connectors installed on the motor or actuator. Refer to MP-Series (Bulletin MPL) Motor Connectors on [page 105](#) for more information on circular DIN and bayonet connectors.

Table 69 - Motor Power Cable Compatibility - Bayonet Connectors

Motor/Actuator	Connector Type	Motor/Actuator Cat. No.	Motor Power Cables (with brake wires)	Motor Power Cables (without brake wires)
MP-Series (Bulletin MPL)	Bayonet	MPL-A/B3xxx-xx2xAA, MPL-A/B4xxx-xx2xAA, MPL-A/B45xxx-xx2xAA, MPL-A/B5xxx-xx2xAA, MPL-B6xxx-xx2xAA, MPL-B8xxx-xx2xAA, MPL-B960B-xx2xAA, MPL-B960C-xx2xAA, MPL-B980B-xx2xAA, and MPL-B980C-xx2xAA	N/A	2090-XXxPMP-xxSxx ⁽¹⁾
1326AB (M2L/S2L)		MPL-B960D-xx2xAA, MPL-B980D-xx2xAA		2090-MCNPMP-6Sxx
F-Series		1326AB-Bxxxx-M2L/S2L		2090-XXxPMP-xxSxx ⁽¹⁾
1326AB (resolver)	P-LOK	F-xxxx	1326-CPx1T-L-xxx (continuous-flex)	2090-XXNPHF-xxSxx
1326AB (resolver)	P-LOK	1326AB-Bxxxx-21	1326-CPx1T-L-xxx (continuous-flex)	N/A

(1) For Bulletin MPL or 1326AB motors equipped with bayonet connectors. These cables are available as standard (catalog number 2090-XXNPMP-xxSxx) and continuous-flex (catalog number 2090-XXTPMP-xxSxx).

Table 70 - Motor Power Cable Compatibility - Threaded DIN and Circular Plastic Connectors

Motor/Actuator	Connector Type	Motor/Actuator Cat. No.	Motor Power Cables (with brake wires)	Motor Power Cables (without brake wires)
MP-Series (Bulletin MPL)	Circular (threaded) DIN	MPL-A/B15xxx-xx4xAA, MPL-A/B2xxx-xx4xAA	2090-XXNPMF-xxSxx (standard) or 2090-CPBM4DF-xxAFxx (continuous-flex)	2090-CPWM4DF-xxAFxx (continuous-flex)
MP-Series (Bulletin MPS)		MPS-A/Bxxxx		
MP-Series (Bulletin MPAS)		MPAS-A/Bxxxx		
MP-Series (Bulletin MPAR)		MPAR-A/B1xxx and MPAR-A/B2xxx (series A)		
TL-Series (Bulletin TLY)	Circular Plastic	TLY-Axxxx-H	2090-CPBM6DF-16AAxx (standard)	2090-CPWM6DF-16AAxx (standard)

Table 71 - Motor Power Cable Compatibility - SpeedTec DIN Connectors

Motor/Actuator	Connector Type	Motor/Actuator Cat. No.	Motor Power Cables ⁽¹⁾ (with brake wires)	Motor Power Cables ⁽¹⁾ (without brake wires)
MP-Series (Bulletin MPL)	Circular (SpeedTec) DIN	MPL-A/B15xxx-xx7xAA, MPL-A/B2xxx-xx7xAA, MPL-A/B3xxx-xx7xAA, MPL-A/B4xxx-xx7xAA, MPL-A/B45xxx-xx7xAA, MPL-A/B5xxx-xx7xAA, MPL-B6xxx-xx7xAA, MPL-B8xxx-xx7xAA, MPL-B9xxx-xx7xAA	2090-CPBM7DF-xxAAxx (standard) or 2090-CPBM7DF-xxAFxx (continuous-flex)	2090-CPWM7DF-xxAAxx (standard) or 2090-CPWM7DF-xxAFxx (continuous-flex)
MP-Series (Bulletin MPM)		MPM-A/Bxxxx		
MP-Series (Bulletin MPF)		MPF-A/Bxxxx		
RDD-Series		RDD-Bxxxx		
LDC-Series		LDC-Cxxxx		
MP-Series (Bulletin MPAL)		MPAL-A/Bxxxx		
MP-Series (Bulletin MPAR)		MPAR-A/B3xxx, MPAR-A/B1xxx and MPAR-A/B2xxx (series B)		
LDL-Series		LDL-xxxxxxx		

(1) You must remove the motor-side o-ring when using 2090-CPxM7DF-xxAAxx cables.

These cables contain only the three-phase power wires. The motors/actuators either have no brake or a separate connector for brake connections. Thermal switch wires are included in the feedback cable.

Refer to Axis Module/Rotary Motor Wiring Examples beginning on [page 196](#) for interconnect diagrams.

Figure 56 - Motor Power Terminations (cables without brake wires)

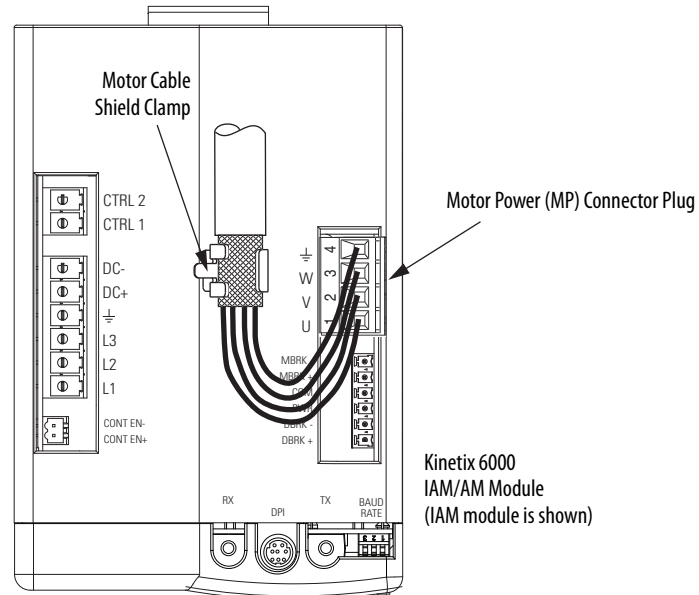

The cable shield clamp shown above is mounted to an IAM module. Cables attach to the clamp on each AM module in the same way.

These cables contain three-phase power wires and brake wires. The brake wires have a shield braid (shown below as gray) that folds back under the cable clamp before the conductors are attached to the motor brake (BC) connector. Thermal switch wires are included in the feedback cable.

Refer to Axis Module/Rotary Motor Wiring Examples beginning on [page 196](#) for interconnect diagrams.

Figure 57 - Motor Power Terminations (cables with brake wires)

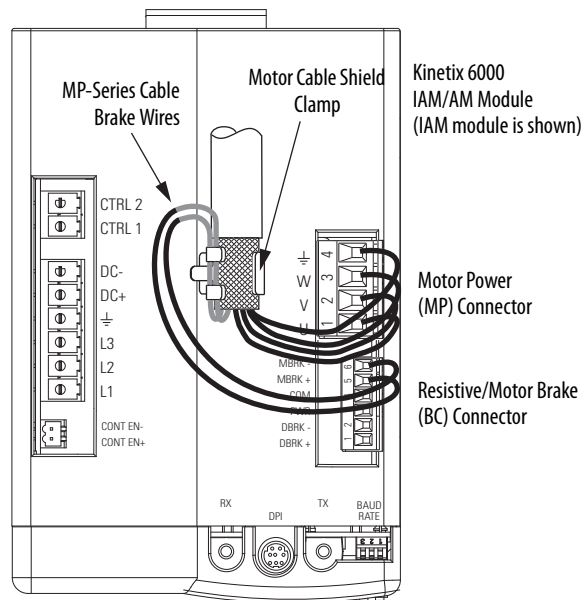

The cable shield clamp shown above is mounted to an IAM module. Cables attach to the clamp on each AM module in the same way.

The 1326AB (resolver) power cables (catalog number 1326-CPx1T-L-xxx) contain the three-phase wires, brake wires, and thermal switch wires. To improve the EMC performance of your system, route the wires as shown.

Refer to Axis Module/Rotary Motor Wiring Examples beginning on [page 196](#) for interconnect diagrams.

Figure 58 - Motor Power Terminations (1326-CPx1T-L-xxx cable)

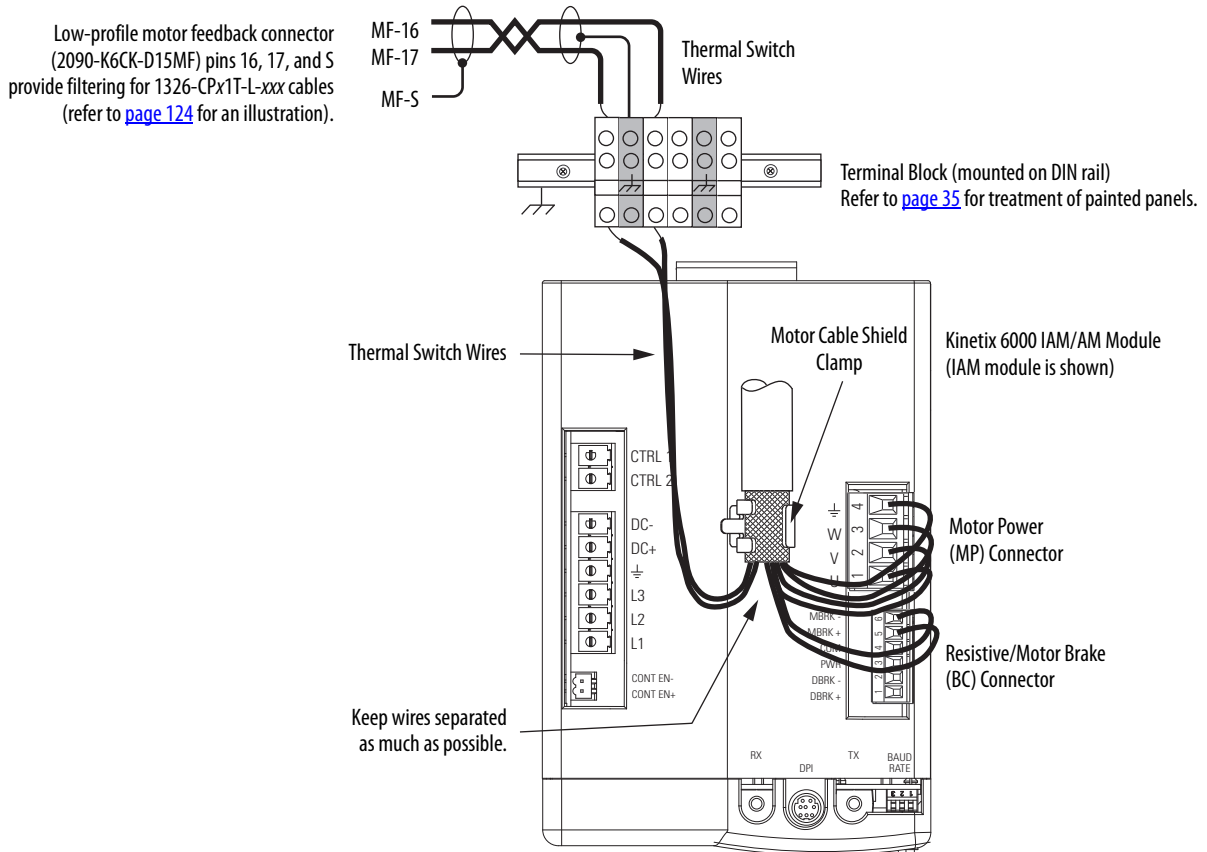

The cable shield clamp shown above is mounted to an IAM module. Cables attach to the clamp on each AM module in the same way.

IMPORTANT We recommend securing the cable shield in the clamp with a tie wrap to improve stress relief.

Cable shield and lead preparation is provided with most Allen-Bradley cable assemblies. Follow these guidelines if your motor power cable shield and wires require preparation.

Figure 59 - Cable Shield and Lead Preparation

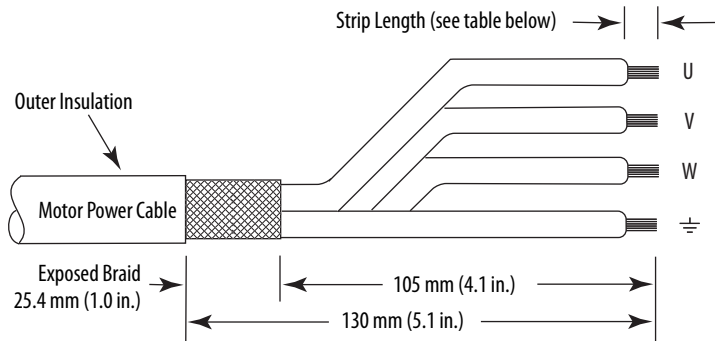

Refer to Axis Module/Rotary Motor Wiring Examples beginning on [page 196](#) for interconnect diagrams.

Table 72 - Motor Power (MP) Connector

Servo Motor		MP Connector (IAM/AM module)	
1326AB (resolver)	All Other Motors	MP Pin	Signal
1 / Black	U / Brown	1	U
2 / Black	V / Black	2	V
3 / Black	W / Blue	3	W
Green/Yellow	⏏ Green/Yellow	4	⏏

Table 73 - Termination Specifications

IAM/AM Module Cat. No.	Recommended Wire Size mm ² (AWG)	Strip Length mm (in.)	Torque Value N·m (lb·in)
2094-AC05-Mxx-x, 2094-AMP5-x, 2094-AM01-x, 2094-AC09-M02-x, 2094-AM02-x, 2094-BC01-Mxx-x, 2094-BMP5-x, 2094-BM01-x, 2094-BC02-M02-x, 2094-BM02-x	Motor power cable depends on motor/drive combination. 6 (10) max	10 (0.38)	0.5...0.6 (4.4...5.3)
2094-AC16-M03-x, 2094-AM03-x, 2094-AC32-M05-x, 2094-AM05-x	10 (8) max	10 (0.38)	1.2...1.5 (10.6...13.2)
2094-BC04-M03-x, 2094-BM03-x	10 (8) max	10 (0.38)	1.2...1.5 (10.6...13.2)
2094-BC07-M05-x, 2094-BM05-x	30 (3) max	16 (0.63)	2.4...3.0 (21.6...26.5)

Wire the Motor/Resistive Brake (BC) Connector

This example applies to AM modules and the inverter section of IAM modules.

Figure 60 - IAM/AM Module (BC connector)

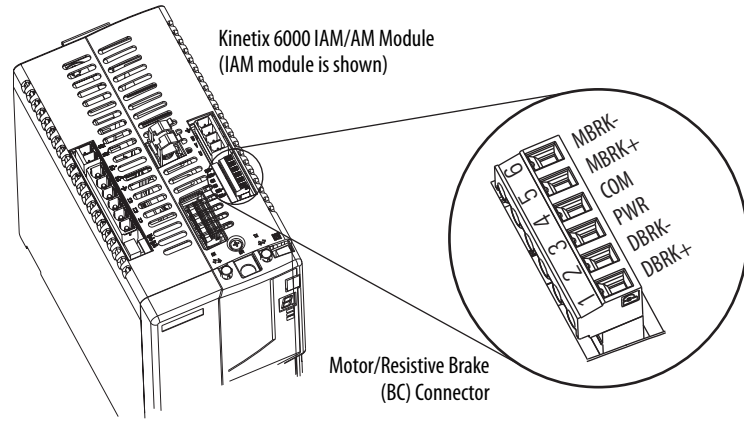

24V DC Brake Input Power Connections

IMPORTANT If your system includes a LIM module, you can source the 24V DC from the LIM module (P1L or PSL connector).

Table 74 - Motor/Resistive Brake (BC) Connector

2094-ALxxS, 2094-BLxxS, 2094-XL75S-Cx LIM Modules		2094-AL09 and 2094-BL02 LIM Modules		BC Connector (IAM/AM modules)	
P1L Pin	Signal	PSL Pin	Signal	BC Pin	Signal
1	IO_PWR2	1	MBRK PWR	3	PWR
2	IO_COM2	2	MBRK COM	4	COM

RBM Module Connections

Table 75 - Motor/Resistive Brake (BC) Connector

RBM Module I/O Connections		BC Connector (IAM/AM modules)	
TB3 Pin	Signal	MP Pin	Signal ⁽¹⁾
6	COIL_A1	1	DBRK+
7	COIL_A2	2	DBRK-

(1) Firmware revision 1.071 or later is required to use the DBRK outputs on the Kinetix 6000 IAM/AM module.

Motor Brake Connections

The procedure for wiring your motor brake varies slightly, depending on the motor family. The cables compatible with your motor or actuator depend on the connectors installed on the motor or actuator. Refer to MP-Series (Bulletin MPL) Motor Connectors on [page 105](#) for more information on circular DIN and bayonet connectors.

Table 76 - Motor Brake Cable Compatibility - Bayonet Connectors

Motor Series	Connector Type	Brake Wires	Cable Cat. No.
MPL-A/B3xxx-xx2xAA, MPL-A/B4xxx-xx2xAA, MPL-A/B45xxx-xx2xAA, MPL-A/B5xxx-xx2xAA, MPL-B6xxx-xx2xAA, MPL-B8xxx-xx2xAA, MPL-B9xxx-xx2xAA	Bayonet	The motor has a brake connector. Brake wires are in the brake cable.	2090-UXxBMP-18Sxx brake cable ⁽¹⁾
1326AB (M2L/S2L)			
F-Series		The motor has a brake connector. Brake wires are in the brake cable.	Straight brake connector kit 9101-0330
1326AB (resolver)	P-LOK		1326-CPx1T-L-xxx power cable

(1) For Bulletin MPL and 1326AB motors equipped with bayonet connectors. These cables are available as standard (catalog number 2090-UXNBMP-18Sxx) and continuous-flex (catalog number 2090-UXTBMP-18Sxx).

Table 77 - Motor Brake Cable Compatibility - Threaded DIN and Circular Plastic Connectors

Motor Series	Connector Type	Brake Wires	Cable Cat. No.
MPL-A/B15xxx-xx4xAA, MPL-A/B2xxx-xx4xAA	Circular (threaded) DIN	The motor/actuator does not have a brake connector. Brake wires are included in the power cable.	2090-XXNPMF-xxSxx (standard) or 2090-CPBM4DF-xxAFxx (continuous-flex)
MPS-A/Bxxx, MPAS-A/Bxxx, MPMA-A/Bxxx, MPAR-A/B1xxx, MPAR-A/B2xxx (series A)			
TLY-Axxxx-H			
	Circular Plastic		2090-CPBM6DF-16AAxx power cable

Table 78 - Motor Brake Cable Compatibility - SpeedTec DIN Connectors

Motor Series	Connector Type	Brake Wires	Cable Cat. No. ⁽¹⁾
MPL-A/B15xxx-xx7xAA, MPL-A/B2xxx-xx7xAA	Circular (SpeedTec) DIN	The motor/actuator does not have a brake connector. Brake wires are included in the power cable.	2090-CPBM7DF-xxAAxx (standard) or 2090-CPBM7DF-xxAFxx (continuous-flex)
MPL-A/B3xxx-xx7xAA, MPL-A/B4xxx-xx7xAA, MPL-A/B45xxx-xx7xAA, MPL-A/B5xxx-xx7xAA, MPL-B6xxx-xx7xAA, MPL-B8xxx-xx7xAA MPL-B9xxx-xx7xAA			
MPM-A/Bxxx, MPF-A/Bxxx			
MPAR-A/B1xxx, MPAR-A/B2xxx (series B), MPAR-A/B3xxx, MPAI-A/Bxxx			

(1) You must remove the motor-side o-ring when using 2090-CFBM7xx-xxAxxx cables.

IMPORTANT Use surge suppression when controlling a brake coil. Refer to Controlling a Brake Example on [page 211](#).

Figure 61 - Brake Cable Preparation

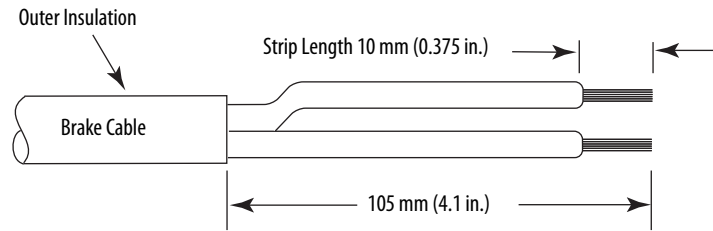

Table 79 - Motor/Resistive Brake (BC) Connector

Motor Brake Wires				BC Connector (IAM/AM module)	
2090-UXxBMP-18Sxx Brake Cable	2090-XXNPMF-xxSxx 2090-CPBMxDF-xxAFxx Power Cable	2090-CPBM6DF-16AAxx Power Cable	1326-CPx1T-L-xxx Power Cable	BC Pin	Signal
A / BR+	F/+ / BR+/MBRK+	7 / MBRK+	6 / B1	5	MBRK+
C / BR-	G/- / BR-/MBRK-	9 / MBRK-	4 / B2	6	MBRK-

Table 80 - Termination Specifications

BC Connector (IAM/AM module)		Recommended Wire Size mm ² (AWG)	Strip Length mm (in.)	Torque Value N·m (lb·in)
BC Pin	Signal			
BC-6	MBRK-	0.75 (18)	10 (0.38)	0.22...0.25 (1.9...2.2)
BC-5	MBRK+			
BC-4	COM			
BC-3	PWR			
BC-2	DBRK-			
BC-1	DBRK+			

Apply the Motor Cable Shield Clamp

This procedure assumes you have completed wiring your motor power (MP) connector and are ready to apply the cable shield clamp.

TIP Your drive can be equipped with either the pivot-open or slide-open cable clamp.

Follow these steps to apply the motor cable shield clamp.

1. Depress the spring loaded clamp.

The pivot-open cable clamp was designed to replace the slide-open cable clamp.

- Pivot-open clamp features include:
- Screwdriver not required for depressing the spring
 - Tie wrap not required or recommended

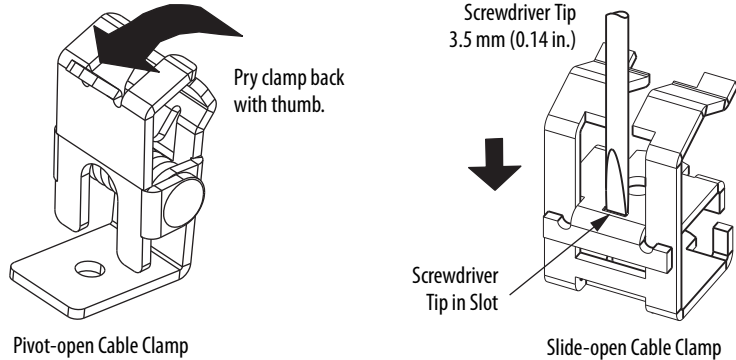

2. Position the exposed portion of the cable braid directly in line with the clamp.
3. Release the spring, making sure the cable and cable braid are held secure by the clamp.
4. Attach tie wrap (slide-open clamp only) around cable and clamp for additional strain relief.

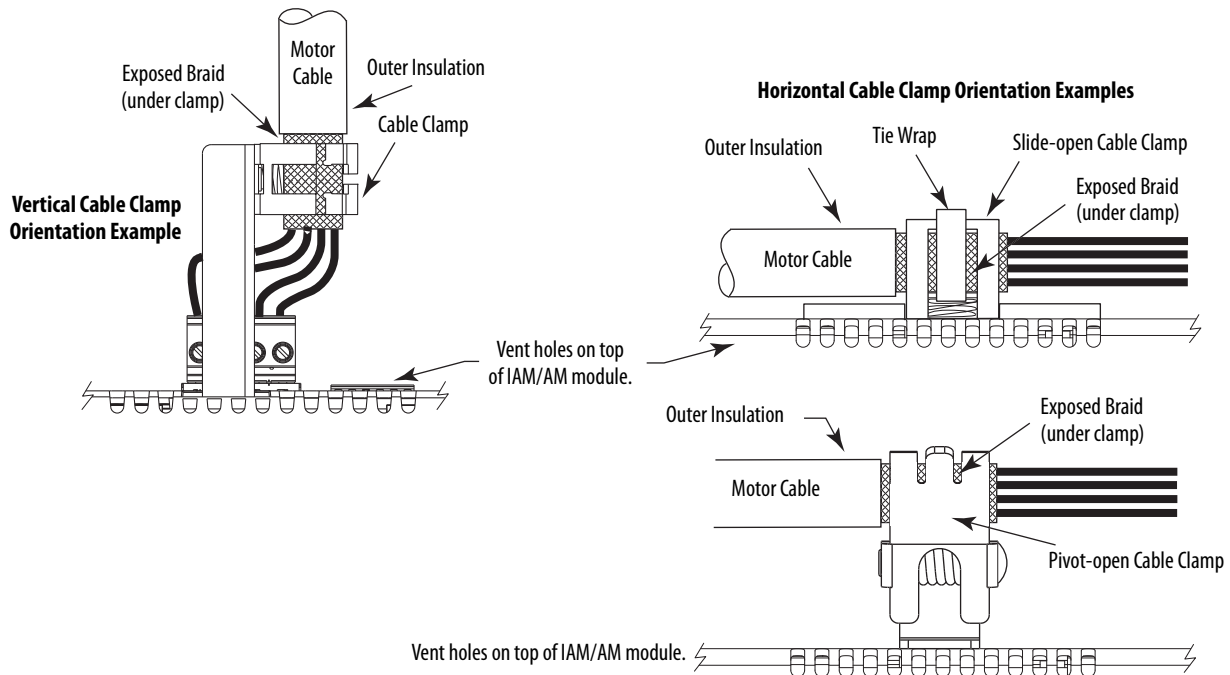

5. Repeat [step 1](#) through [step 4](#) for each IAM, AM, or IPIM module.

Feedback and I/O Cable Connections

Factory made cables with premolded connectors are designed to minimize EMI and are recommended over hand-built cables to improve system performance. However, other options are available for building your own feedback and I/O cables.

Table 81 - Options for Connecting Motor Feedback and I/O

Connection Option	Connector Kit Cat. No.	Cable	Using this Type of Cable
Premolded connector	N/A	Motor feedback	Refer to Table 82 and Table 83 for the flying-lead cable available for your motor.
Low-profile connector kit	2090-K6CK-D15M	Motor feedback	
	2090-K6CK-D26M	I/O interface	User-supplied flying-lead cable.
Low-profile connector kit	2090-K6CK-D15F	Auxiliary feedback	User-supplied flying-lead cable.
	2090-K6CK-D15MF	Motor feedback	1326-CCUT-L-xxx flying-lead feedback cable.
Low-profile feedback module	2090-K6CK-KENDAT		Refer to Table 82 . . . Table 84 for the flying-lead cable available for your motor.
Panel-mounted breakout board kit	2090-UXBK-D15xx ⁽¹⁾	Motor feedback	Refer to Table 82 . . . Table 84 for the flying-lead cable available for your motor.

(1) Not compatible with 1326-CCUT-L-xxx cable.

The procedure for wiring your motor feedback varies slightly, depending on the motor family. The cables compatible with your motor or actuator depend on the connectors installed on the motor or actuator. Refer to MP-Series (Bulletin MPL) Motor Connectors on [page 105](#) for more information on circular DIN and bayonet connectors.

Table 82 - Motor Feedback Cable Compatibility - Bayonet Connectors

Motor/Actuator	Connector Type	Feedback Type	Feedback Cable	
			Premolded	Flying-lead
MPL-A/Bxxxx-S/Mx2xAA	Bayonet	High-resolution encoder	2090-UXNFBMP-Sxx	2090-XXxFMP-Sxx ⁽¹⁾
MPL-A3xxx-Hx2xAA MPL-A4xxx-Hx2xAA MPL-A45xxx-Hx2xAA		Incremental encoder		
MPL-B3xxx-Rx2xAA MPL-B4xxx-Rx2xAA MPL-B45xxx-Rx2xAA		Motor resolver	N/A	2090-CDNFDMP-Sxx
1326AB-Bxxxx-M2L/S2L		High-resolution encoder	2090-UXNFBMP-Sxx	2090-XXxFMP-Sxx ⁽¹⁾
1326AB-Bxxxx-21		Motor resolver	N/A	1326-CCUT-L-xxx
F-Series		Incremental encoder	2090-UXNFBHF-Sxx	2090-XXNFHF-Sxx

(1) For Bulletin MPL and 1326AB (M2L/S2L) motors equipped with bayonet connectors. These cables are available as standard (catalog number 2090-XXNFMP-Sxx) and continuous-flex (catalog number 2090-XXTFMP-Sxx).

Refer to Flying-lead Feedback Cable Pinouts beginning on [page 117](#) for the motor-to-drive feedback cable pinout used in your application.

Refer to MP-Series (Bulletin MPL) Motor Connectors on [page 105](#) for more information on circular DIN and bayonet connectors.

Table 83 - Motor Feedback Cable Compatibility - Threaded DIN/Plastic Connectors

Motor/Actuator	Connector Type	Feedback Type	Feedback Cable ⁽¹⁾	
			Premolded	Flying-lead
MPL-A/B15xxx-V/Ex4xAA MPL-A/B2xxx-V/Ex4xAA	Circular (threaded) DIN	High-resolution encoder	N/A	2090-XXNFMF-Sxx (standard) or 2090-CFBM4DF-CDAFxx (continuous-flex)
MPL-A/B15xxx-Hx4xAA MPL-A/B2xxx-Hx4xAA		Incremental encoder		
MPS-A/Bxxxx-S/M		High-resolution encoder		
MPAS-A/Bxxxx-V/A MPAR-A/B1xxx-V and MPAR-A/B2xxx-V (series A)				
TLY-Axxxx-H	Circular Plastic	Incremental encoder	2090-CFBM6DD-CCAAxx	2090-CFBM6DF-CBAxx

(1) You must remove the motor-side o-ring when using 2090-CFBM7xx-xxAxxx cables.

Table 84 - Motor Feedback Cable Compatibility - SpeedTec DIN Connectors

Motor/Actuator	Connector Type	Feedback Type	Feedback Cable ⁽¹⁾	
			Premolded	Flying-lead
MPL-A/B15xxx-V/Ex7xAA MPL-A/B2xxx-V/Ex7xAA	Circular (SpeedTec) DIN	High-resolution encoder	2090-CFBM7DD-CEAAxx (standard) or 2090-CFBM7DD-CEAFxx (continuous-flex)	2090-CFBM7DF-CEAAxx (standard) or 2090-CFBM7DF-CEAFxx (continuous-flex)
MPL-A/B15xxx-Hx7xAA MPL-A/B2xxx-Hx7xAA		Incremental encoder		
MPL-A/B3xxx-S/Mx7xAA, MPL-A/B4xxx-S/Mx7xAA, MPL-A/B45xxx-S/Mx7xAA, MPL-A/B5xxx-S/Mx7xAA, MPL-B6xxx-S/Mx7xAA, MPL-B8xxx-S/Mx7xAA MPL-B9xxx-S/Mx7xAA		High-resolution encoder		
MPL-A/B3xxx-Hx7xAA ⁽²⁾ MPL-A/B4xxx-Hx7xAA ⁽²⁾ MPL-A/B45xxx-Hx7xAA ⁽²⁾ LDAT-Sxxxxxx-xBx ⁽²⁾		Incremental encoder		
MPL-B3xxx-Rx7xAA MPL-B4xxx-Rx7xAA MPL-B45xxx-Rx7xAA	Circular (SpeedTec) DIN	Motor resolver	N/A	2090-CFBM7DF-CEAAxx (standard) or 2090-CFBM7DF-CEAFxx (continuous-flex)
MPM-A/Bxxxx-2	Circular (SpeedTec) DIN	High-resolution encoder	2090-CFBM7DD-CEAAxx (standard) or 2090-CFBM7DD-CEAFxx (continuous-flex)	2090-CFBM7DF-CEAAxx (standard) or 2090-CFBM7DF-CEAFxx (continuous-flex)
MPF-A/Bxxxx-S/M				
MPM-A/Bxxxx-S/M				
MPAR-A/B1xxx-V and MPAR-A/B2xxx-V (series B) MPAR-A/B3xxx-M			N/A	2090-XXNFMF-Sxx (standard) or 2090-CFBM7DF-CDAFxx (continuous-flex)
MPAI-A/BxxxxM3				
RDB-Bxxxx-7/3				
LDC-Cxxxx or LDL-xxxx ⁽²⁾	Sin/Cos encoder or TTL encoder	N/A	2090-XXNFMF-Sxx (standard) or 2090-CFBM7DF-CDAFxx (continuous-flex)	

(1) You must remove the motor-side o-ring when using 2090-CFBM7xx-xxAxxx cables.

(2) These motors/linear thrusters are equipped with SpeedTec DIN connectors, however, the feedback option requires the additional conductors supplied with the cables listed.

Refer to Flying-lead Feedback Cable Pinouts beginning on [page 117](#) for the motor-to-drive feedback cable pinout used in your application.

Flying-lead Feedback Cable Pinouts

Table 85 - 2090-XXxFMP-Sxx Feedback Cable ⁽¹⁾

Bayonet Connector Pin	High-resolution Feedback		Incremental Feedback	Drive MF Connector Pin
Rotary Motors	MPL-B3xxx...MPL-B9xxx-M/Sx2xAA MPL-A5xxx-M/Sx2xAA 1326AB-Bxxx-M2L/S2L	MPL-A3xxx-M/Sx2xAA MPL-A4xxx-M/Sx2xAA MPL-A45xxx-M/Sx2xAA	MPL-A3xxx-Hx2xAA MPL-A4xxx-Hx2xAA MPL-A45xxx-Hx2xAA	
A	Sin+	Sin+	AM+	1
B	Sin-	Sin-	AM-	2
C	Cos+	Cos+	BM+	3
D	Cos-	Cos-	BM-	4
E	Data+	Data+	IM+	5
F	Data-	Data-	IM-	10
K	Reserved	EPWR_5V	EPWR_5V	14
L	Reserved	ECOM	ECOM	6
N	EPWR_9V	Reserved	Reserved	7
P	ECOM	Reserved	Reserved	6
R	TS+	TS+	TS+	11
S	TS-	TS-	TS-	–
T	Reserved	Reserved	S1	12
U	Reserved	Reserved	S2	13
V	Reserved	Reserved	S3	8

(1) These cables are available as standard (catalog number 2090-XXNFMP-Sxx) and continuous-flex (catalog number 2090-XXTFMP-Sxx).

Table 86 - 2090-CFBM7DF-CEAAxx Feedback Cable

Motor DIN Connector Pin	Resolver Feedback MPL-Bxxxx-Rx7xAA MPM-xxxxxx-2	Drive MF Connector Pin
1	S2	1
2	S4	2
3	S1	3
4	S3	4
5	R1	5
6	R2	10
11	EPWR_9V	7
12	ECOM	6
13	TS+	11
14	TS-	6

Table 87 - 2090-CDNFDMP-Sxx Feedback Cable

Motor Bayonet Connector Pin	Resolver Feedback MPL-Bxxxx-Rx2xAA	Drive MF Connector Pin
A	S2	1
B	S4	2
C	S1	3
D	S3	4
G	R1	5
H	R2	10
N	EPWR_9V	7
P	ECOM	6
R	TS+	11
S	TS-	6

Table 88 - 2090-XXNFMF-Sxx or 2090-CFBMxDF-xxAxxx Feedback Cables

Circular DIN Connector Pin	High-resolution Feedback		Incremental Feedback	Drive MF Connector Pin
Rotary Motors	MPL-B15xxx...MPL-B2xxx-V/Ex4/7xAA MPF/MPS-Bxxx-M/S MPF-A5xxx-M/S	MPL-A15xxx...MPL-A2xxx-V/Ex4/7xAA MPF/MPS-A3xx-M/S MPF/MPS-A4xx-M/S MPF/MPS-A45xx-M/S MPS-A5xxx-M/S RDB-Bxxxxx-3/7 MPL-A3xxx-M/Sx7xAA MPL-A4xxx-M/Sx7xAA MPL-A45xxx-M/Sx7xAA MPM-A115xxx...MPM-A130xxx-M/S	MPL-A15xxx-Hx4/7xAA MPL-A2xxx-Hx4/7xAA MPL-B15xxx-Hx4/7xAA MPL-B2xxx-Hx4/7xAA MPL-A3xxx-Hx7xAA MPL-A4xxx-Hx7xAA MPL-A45xxx-Hx7xAA	
	MPL-B3xxx...MPL-B9xxx-M/Sx7xAA MPL-A5xxx-M/Sx7xAA MPM-A165xxx...MPM-A215xxx MPM-Bxxxxx-M/S			
Linear Motors	N/A	LDC-Cxxx and LDL-xxxx	LDC-Cxxx and LDL-xxxx	
Linear Actuators	MPAS-Bxxxxx-VxxSxA MPAR-Bxxxx, MPAL-Bxxxx	MPAS-Axxxxx-VxxSxA MPAR-Axxxx, MPAL-Axxxx	MPAS-A/Bxxxxx-ALMx2C LDAT-Sxxxxx-xBx	
1	Sin+	Sin+	AM+	1
2	Sin-	Sin-	AM-	2
3	Cos+	Cos+	BM+	3
4	Cos-	Cos-	BM-	4
5	Data+	Data+	IM+	5
6	Data-	Data-	IM-	10
7	Reserved	CLK+ ⁽¹⁾	Reserved	9
8	Reserved	CLK- ⁽¹⁾	Reserved	15
9	Reserved	EPWR_5V	EPWR_5V	14
10	Reserved	ECOM	ECOM	6
11	EPWR_9V	Reserved	Reserved	7
12	ECOM	Reserved	Reserved	6
13	TS+	TS+	TS+	11
14	TS-	TS-	TS-	—
15	Reserved	Reserved	S1	12
16	Reserved	Reserved	S2	13
17	Reserved	Reserved	S3	8

(1) Applies to RDB-Bxxxxx-3/7 direct-drive motors only.

Table 89 - 2090-CFBM6DF-CBAxx Feedback Cable

Rotary Motor Connector Pin	Incremental Feedback	Drive MF Connector Pin	Rotary Motor Connector Pin	Incremental Feedback	Drive MF Connector Pin
	TLY-Axxxx-H			TLY-Axxxx-H	
9	AM+	1	15	S1	12
10	AM-	2	17	S2	13
11	BM+	3	19	S3	8
12	BM-	4	22	EPWR_5V	14
13	IM+	5	23	ECOM	6
14	IM-	10	24	Shield	Connector housing

Table 90 - 2090-XXNFHF-Sxx Feedback Cable

Rotary Motor Connector Pin	Incremental Feedback	Drive MF Connector Pin
	F-Series Motors	
A	AM+	1
B	AM-	2
C	BM+	3
D	BM-	4
E	IM+	5
F	IM-	10
G	Reserved	–
H	Reserved	–
J	EPWR_5VM	14
K	EPWR_5VM	14
L	ECOMM	6
M	ECOMM	6
N	S2	13
P	S3	8
R	TS+	11
S	TS-	6
T	S1	12

Table 91 - 1326-CCUT-L-xxx Feedback Cable

Rotary Motor Connector Pin	Resolver Feedback 1326AB-Bxxxx-21	Drive MF Connector Pin ⁽¹⁾
A	R1	5
B	R2	10
C	–	–
D	S1	3
E	S3	4
F	–	–
G	S2	1
H	S4	2

Table 92 - 1326-CPx1T-L-xxx Power Cable

Rotary Motor Connector Pin	Thermal Switch Connections 1326AB-Bxxxx-21	Drive MF Connector Pin ⁽²⁾
5	TS+	16
9	TS-	17
–	Shield	5

(1) For termination of individual drain wires, use Low Profile connector kit (catalog number 2090-K6CK-D15MF) and reference figure on [page 124](#).

(2) Thermal switch wires (5 and 9) are in the motor power cable (catalog number 1326-CPx1T-L-xxx). Use Low Profile connector kit (catalog number 2090-K6CK-D15MF) and reference figure on [page 124](#).

Wiring the Feedback and I/O Connectors

These procedures assume you have mounted your Kinetix 6000 system, completed all power wiring, and are ready to connect your feedback and I/O cables.

For This Connection	Go to
Premolded cable	Connect Premolded Motor Feedback Cables on page 120 .
Panel-mounted breakout board	Connect Panel-mounted Breakout Board Kits on page 121 .
Low-profile connector	Wire Low-profile Connector Kits on page 122 .

Connect Premolded Motor Feedback Cables

Motor feedback cables with premolded connectors plug directly into 15-pin motor feedback (MF) connectors on either the IAM or AM modules (no wiring is necessary).

IMPORTANT When using Bulletin 2090 cables with premolded connectors, tighten the mounting screws (finger tight) to improve system performance.

Figure 62 - IAM/AM Module (MF connector)

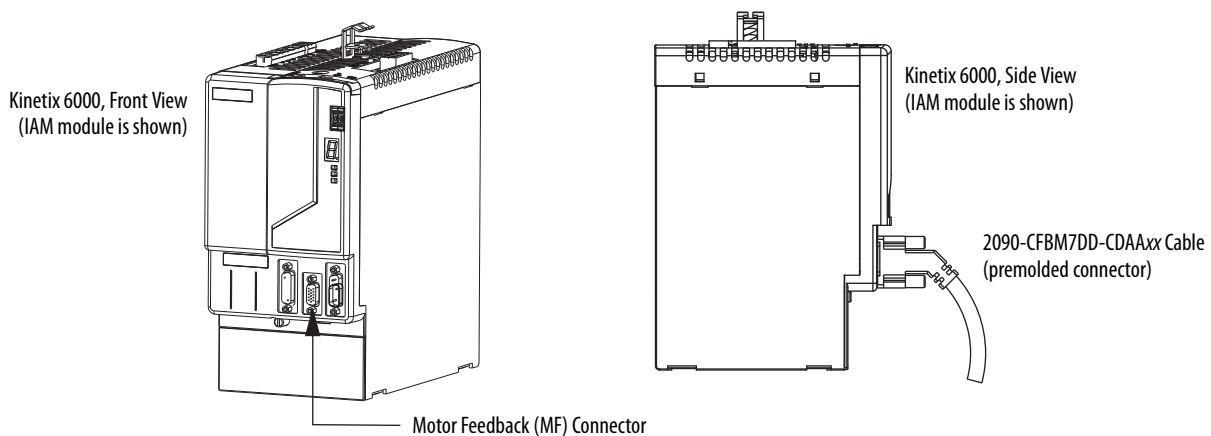

Connect Panel-mounted Breakout Board Kits

The 2090-UXBK-D15xx panel-mounted breakout board kit includes a DIN-rail breakout board and cable. The cable connects between the breakout board and the motor feedback (MF) connector. Wires from your flying-lead motor feedback cable connect to the terminals.

Figure 63 - IAM/AM Module (MF connector)

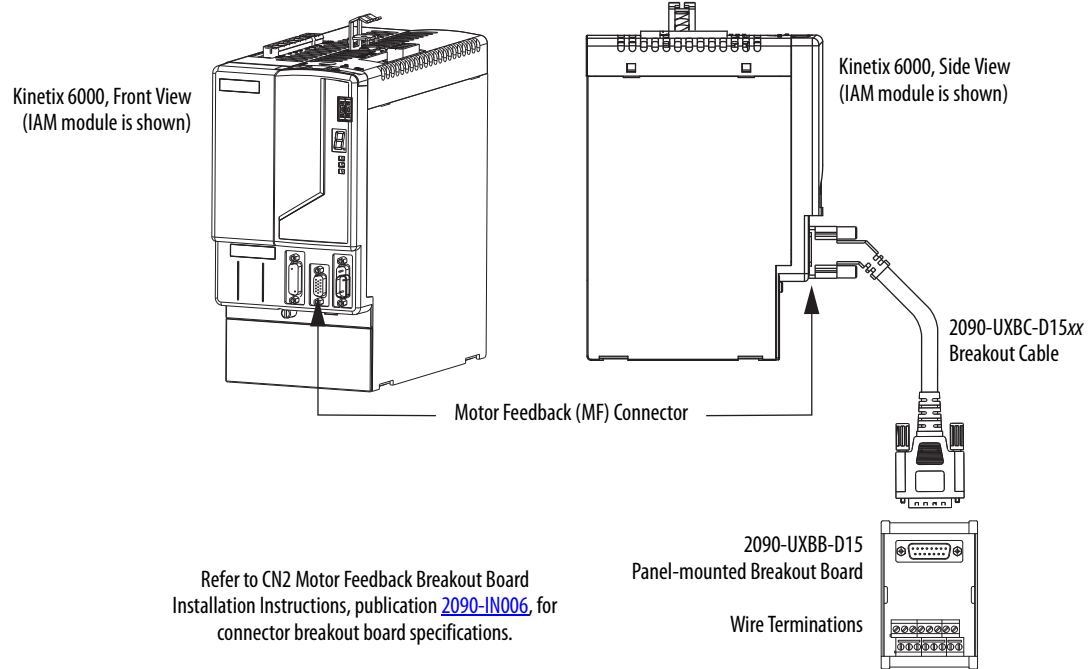

IMPORTANT The panel-mounted breakout board kit (2090-UXBK-D15xx) is not compatible with 1326-CCUT-L-xxx cable.

Wire Low-profile Connector Kits

The 2090-K6CK-xxxx low-profile connector kits are suitable for terminating flying-lead motor feedback, auxiliary feedback, and I/O connections. They also apply to I/O connections on the 2094-AL09 and 2094-BL02 LIM modules.

Table 93 - Low-profile Connector Kits

Connector Kit Cat. No.	Description	Cable Compatibility
2090-K6CK-KENDAT	Low-profile feedback module for EnDat to Hiperface conversion (15-pin, male, D-sub). Use with any Kinetix 6000 IAM/AM module and Bulletin RDB direct-drive motor with EnDat high-resolution feedback.	2090-XXNFMF-Sxx, 2090-CFBM7DF-CEAFxx
2090-K6CK-D15M	Low-profile connector kit for motor feedback (15-pin, male, D-sub). Use with any Kinetix 6000 IAM/AM module and compatible motors with incremental or high-resolution feedback.	2090-XXxFMP-Sxx, 2090-XXNFMF-Sxx, 2090-XXNFHF-Sxx, 2090-CFBMxDF-CxAxxx
2090-K6CK-D15M	Low-profile connector kit for motor feedback (15-pin, male, D-sub). Use with Kinetix 6000 IAM/AM module and MPL-Bxxxx-R (resolver feedback) motors.	2090-CDNFDMP-Sxx 2090-CFBM7DF-CEAAxx 2090-CFBM7DF-CEAFxx
2090-K6CK-D15MF	Low-profile connector kit for motor feedback (15-pin, male, D-sub) with filter. Use with Kinetix 6000 IAM/AM module and 1326ABxxx-21 (resolver feedback) motors.	1326-CCUT-L-xxx
2090-K6CK-D15F	Low-profile connector kit for auxiliary feedback (15-pin, female, D-sub). Use with any Kinetix 6000 IAM/AM module for auxiliary feedback applications.	Customer Supplied
2090-K6CK-D26M	Low-profile connector kit for I/O (26-pin, male, D-sub). Use with any Kinetix 6000 IAM/AM module or 2094-AL09 and 2094-BL02 LIM module for making I/O connections.	Customer supplied

Figure 64 - IAM/AM Module (IOD/MF/AF connectors)

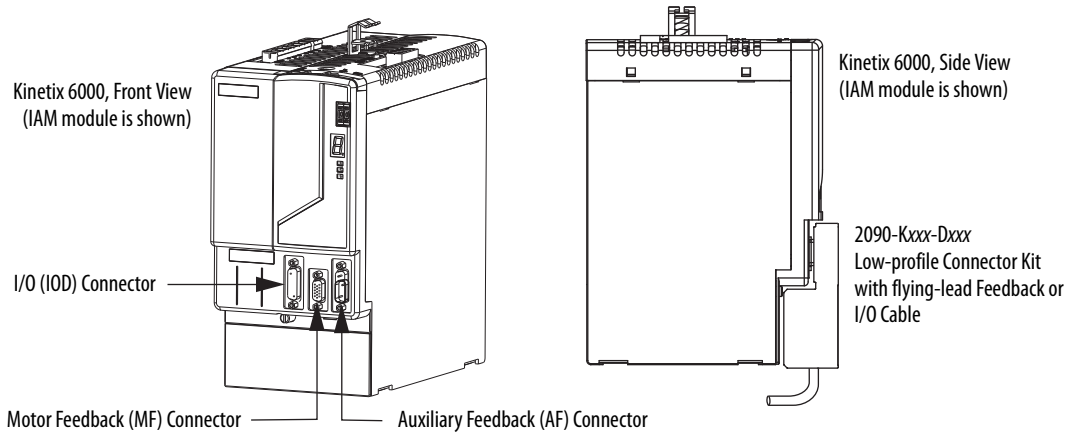

**Figure 65 - Wiring (15-pin) Flying-lead Feedback Cable Connections
2090-K6CK-D15M and 2090-K6CK-D15F Connector Kit**

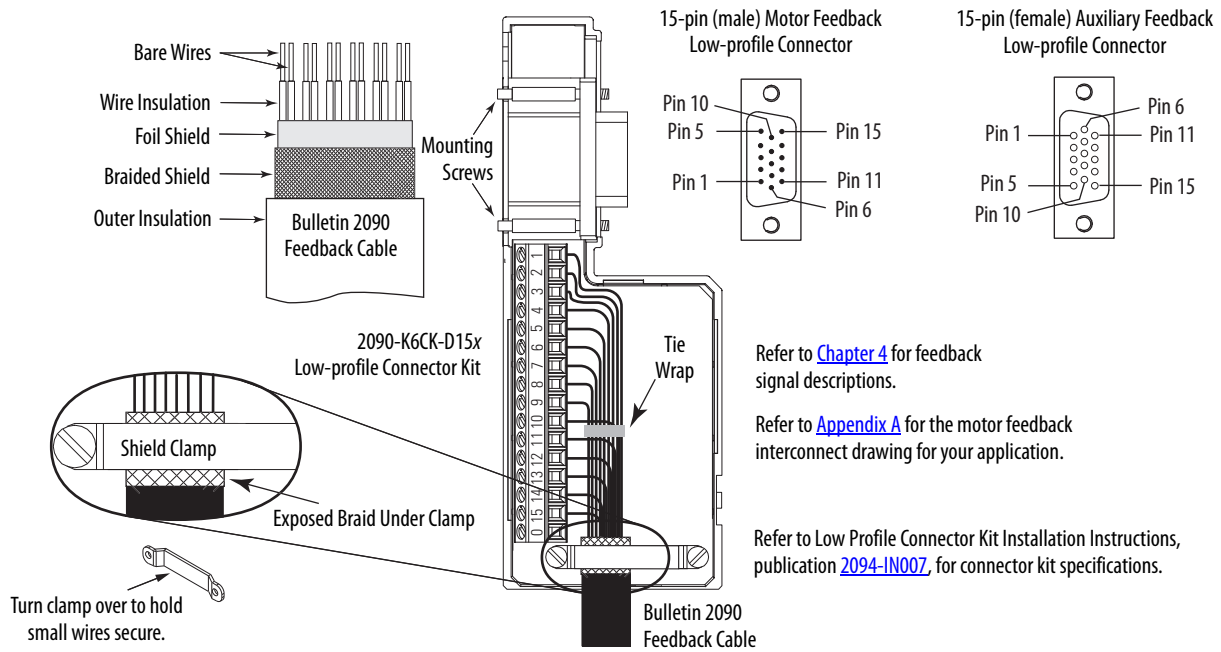

**Figure 66 - Wiring (15-pin) Flying-lead Feedback Cable Connections
2090-K6CK-KENDAT Feedback Module**

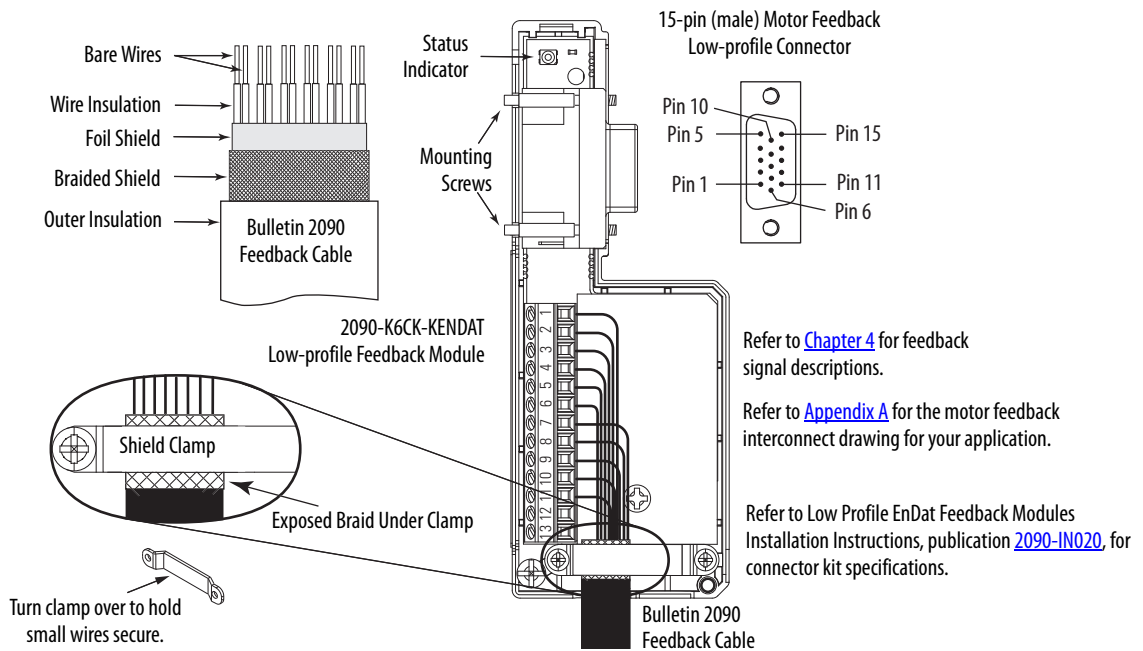

**Figure 67 - Wiring (15-pin) Flying-lead Feedback Cable Connections
2090-K6CK-D15MF Connector Kit**

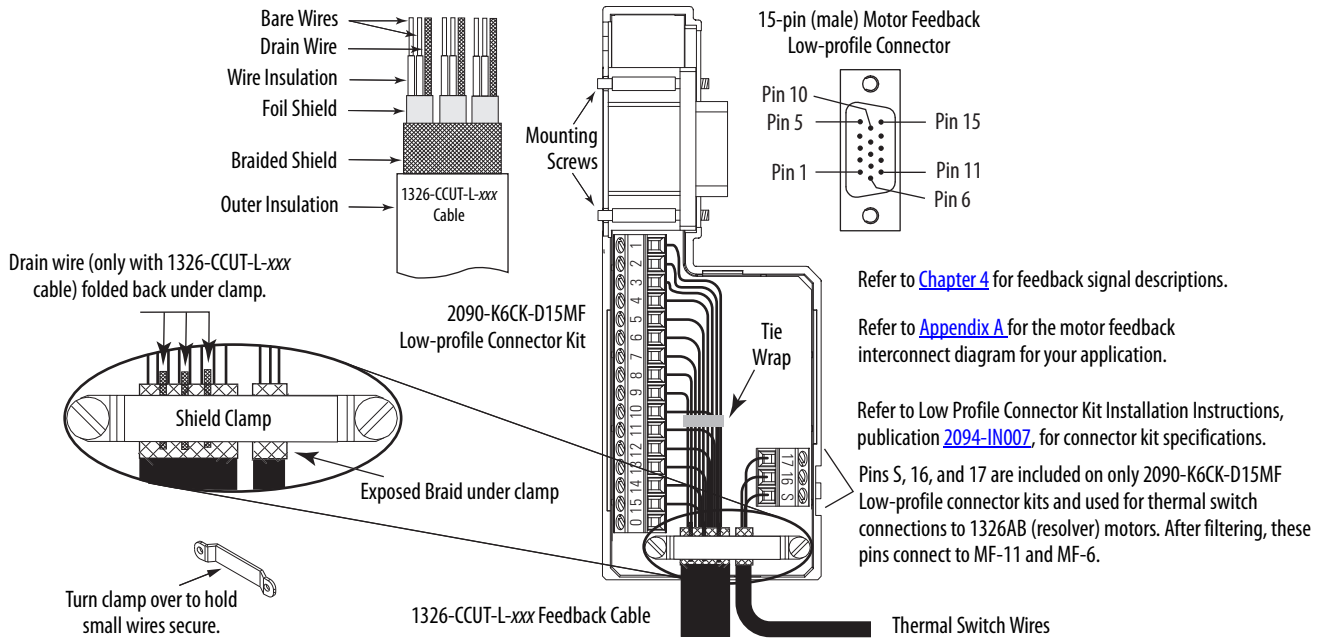

IMPORTANT

The purpose of the cable shield clamp is to provide a proper ground and improve system performance, not stress relief.

Clamping the exposed braid under the shield clamp is critical. Turn clamp over, if necessary, to be sure of a proper ground.

**Figure 68 - Wiring (26-pin) Flying-lead I/O Cable Connections
2090-K6CK-D26M Connector Kit**

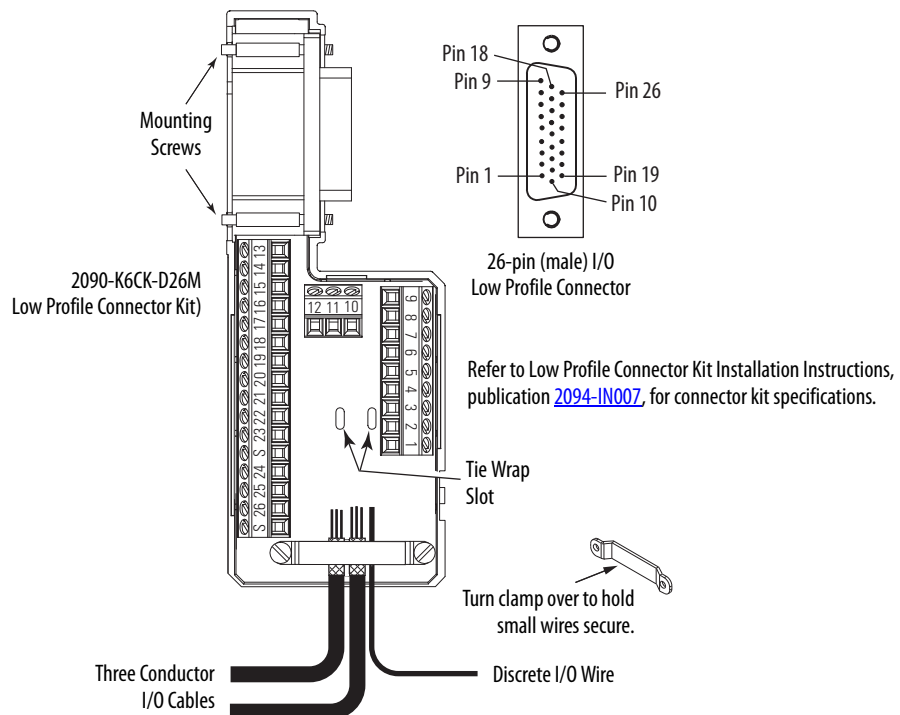

External Shunt Module Connections

Follow these guidelines when wiring your external active or passive shunt module.

IMPORTANT When tightening screws to secure the wires, refer to the tables beginning on [page 95](#) for torque values.

IMPORTANT To improve system performance, run wires and cables in the wireways as established in [Chapter 2](#).

Figure 69 - Shunt Module Wiring

Use This Shunt Module	Cat. No.	With This Drive Module	Do This
Power rail mounted shunt module.	2094-BSP2	N/A	<ul style="list-style-type: none"> Verify the internal shunt jumper is in place between RC-2 and RC-3 (refer to Figure 70). Verify the thermal switch jumper is in place between TS-1 and TS-2 (refer to Figure 70).
External passive shunt module connected to the power rail shunt module.	1394-SRxxxx	2094-BSP2 Shunt module	<ul style="list-style-type: none"> Remove the internal shunt jumper between RC-2 and RC-3. Remove the thermal switch jumper between TS-1 and TS-2 (if your shunt module includes a thermal switch). Refer to External Shunt Modules on page 48 for noise zone considerations. Refer to Shunt Module Wiring Examples on page 195. Refer to the installation instructions provided with your Bulletin 1394 shunt module, publication 2090-IN004.

Figure 70 - Shunt Module Jumper Settings

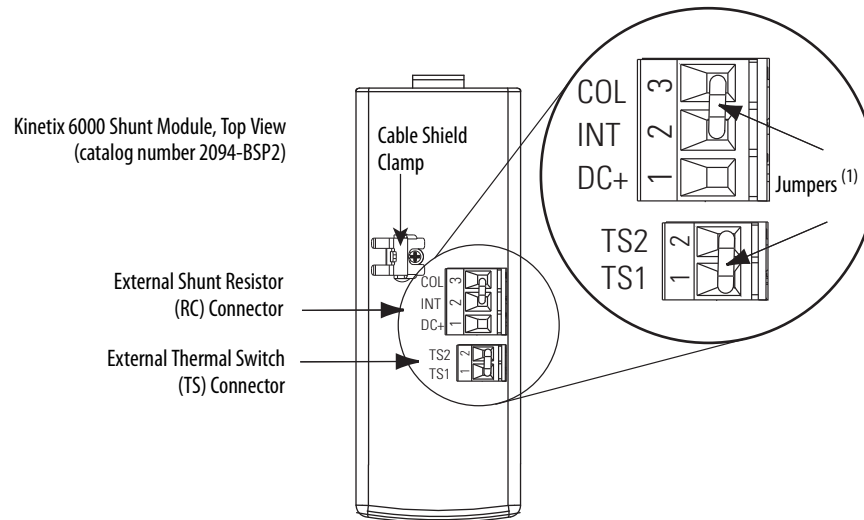

(1) These are the default jumper settings.

IPIM Module Connections

An overview of the Kinetix 6000M integrated drive-motor (IDM) system connections are shown here.

- Refer to Chapter 2 on [page 25](#), for noise zone considerations.
- Refer to Appendix A, on [page 210](#), for an interconnect diagram featuring the Kinetix 6000M integrated drive-motor (IDM) system.
- Refer to the Kinetix 6000M Integrated Drive-Motor System User Manual, publication [2094-UM003](#), for more information when wiring your IPIM module.

IMPORTANT To improve system performance, run wires and cables in the wireways as established in [Chapter 2](#).

Figure 71 - IPIM Module Connections

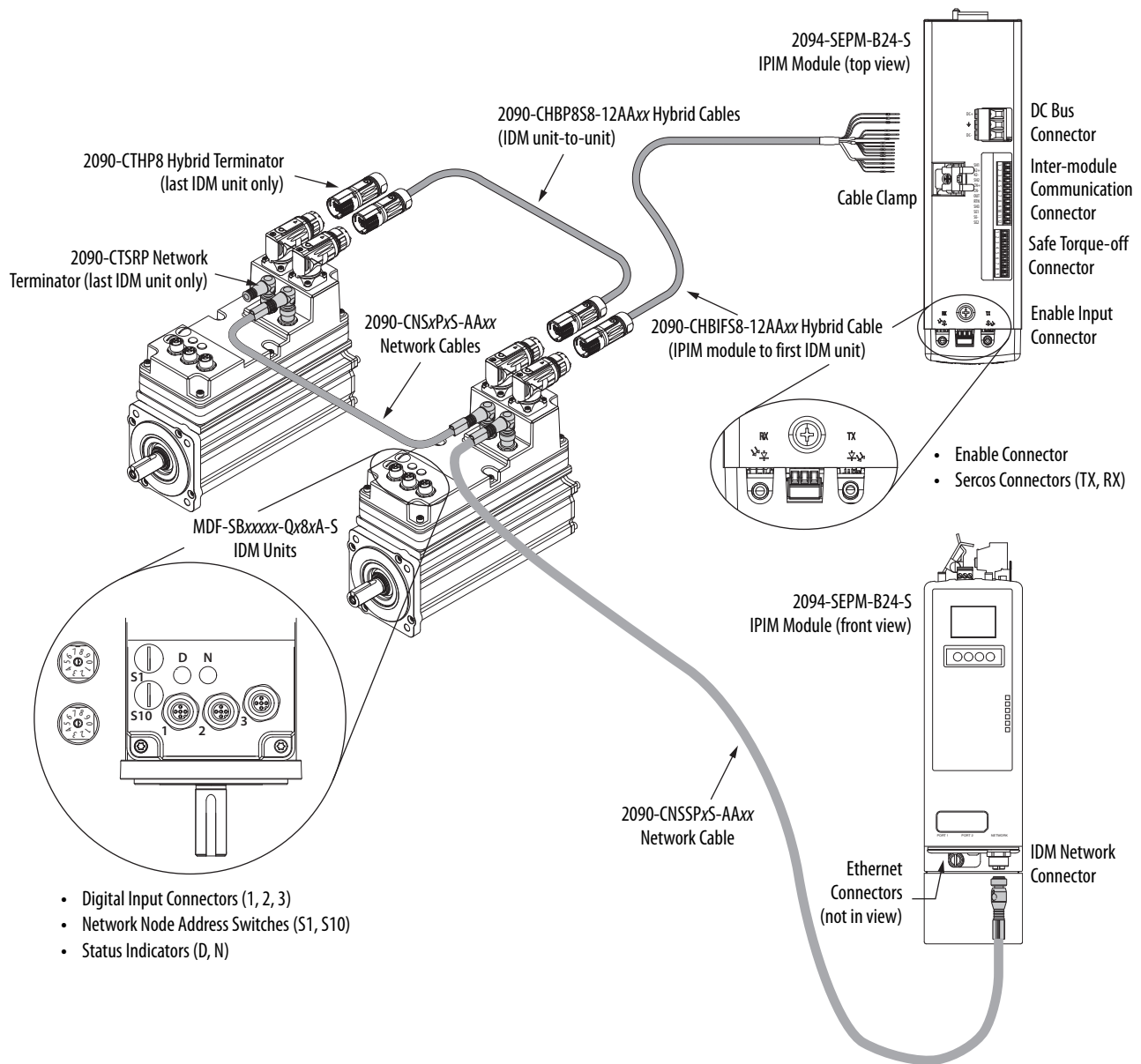

RBM Module Connections

Follow these guidelines when wiring your Bulletin 2090 Resistive Brake Module (RBM).

IMPORTANT To be sure of system performance, run wires and cables in the wireways as established in [Chapter 2](#).

If your application requires an RBM module and you are wiring to a Kinetix 6000 IAM/AM module, then refer to the following:

- Cable Categories for Kinetix 6000 Systems on [page 45](#) to establish noise zones when mounting the RBM module on your panel.
- Resistive brake module to Kinetix 6000 drive interface cable (catalog number 2090-XXNRB-xxFOPx).
- The example diagram below and others in Appendix G, beginning on [page 265](#).
- The installation instructions provided with your RBM module, publication [2090-IN009](#).

Figure 72 - RBM Module Connections

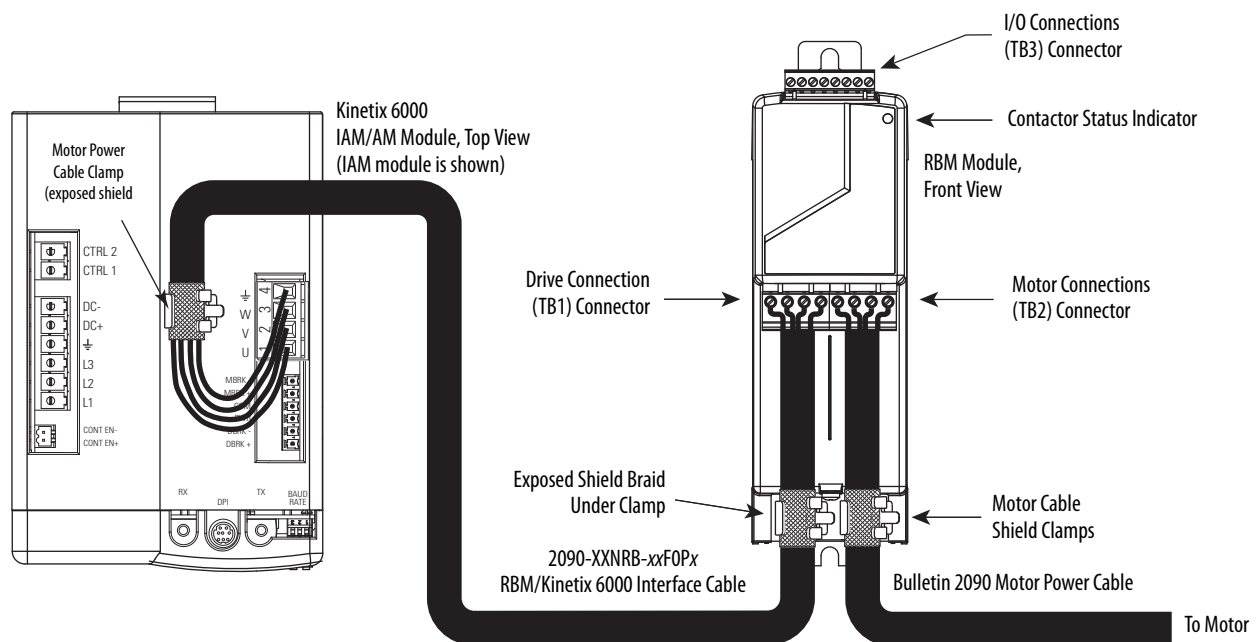

Sercos Fiber-optic Cable Connections

This procedure assumes you have your Logix5000 sercos interface module/PCI card and Kinetix 6000 IAM/AM modules mounted and are ready to connect the fiber-optic cables.

The sercos fiber-optic ring is connected by using the sercos receive (Rx) and transmit (Tx) connectors. Refer to [page 58](#) to locate the sercos connectors on your Kinetix 6000 IAM/AM module and IPIM module. Refer to the figure below to locate the connectors on your Logix5000 sercos interface module or PCI card.

Plastic cable is available in lengths up to 32 m (105.0 ft). Glass cable is available in lengths between 50 m (164.2 ft) and 200 m (656.7 ft).

Figure 73 - CompactLogix, ControlLogix, and SoftLogix Sercos Connectors

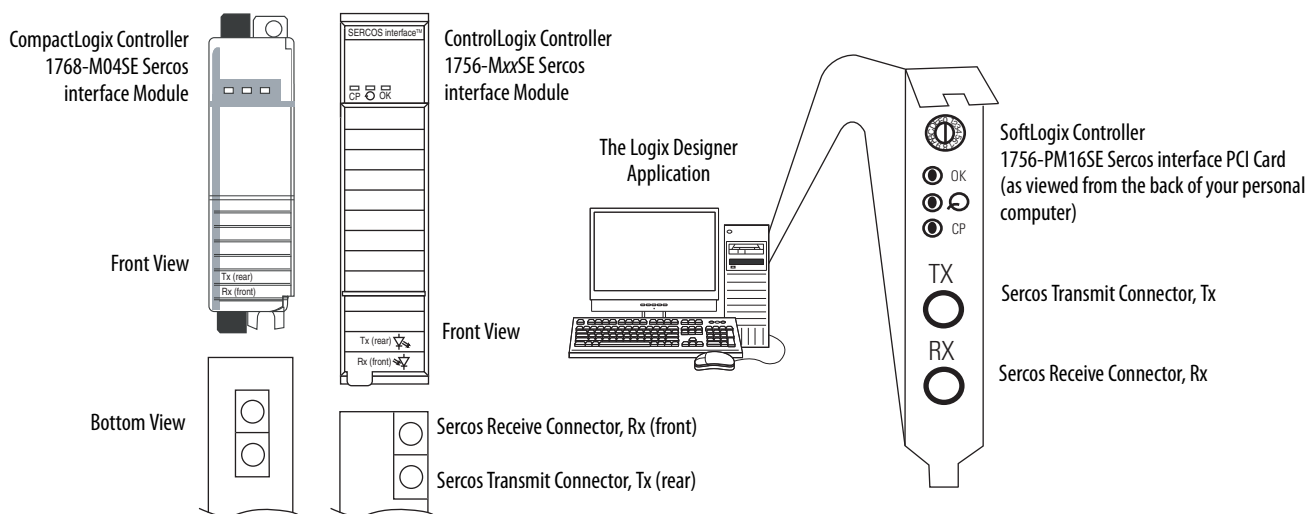

Connect the cable from transmit on the Logix5000 module to receive on the IAM/AM or IPIM module, then transmit to receive (drive to drive), and from transmit on the last drive back to receive on the Logix5000 module.



ATTENTION: To avoid damage to the sercos Rx and Tx connectors, use only finger-tight torque when attaching the fiber-optic cables to the Kinetix 6000 IAM/AM modules and IPIM module. Do not use a wrench or any other mechanical assistance.

For more information, refer to Fiber-optic Cable Installation and Handling Instructions, publication [2090-IN010](#).

SoftLogix and ControlLogix controllers are used in the following examples; however, CompactLogix controllers connect in the same manner.

Figure 74 - Fiber-optic Cable Example - SoftLogix Controller

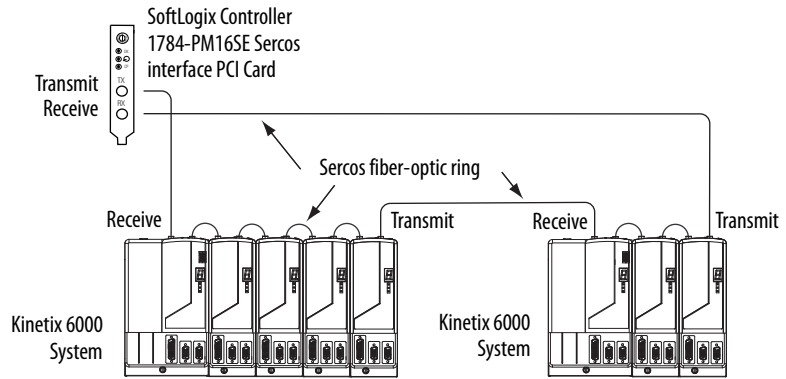

IMPORTANT The CompactLogix controller (catalog number 1768-M04SE) is limited to four axes per module.

In this example, two Logix5000 modules are installed in separate chassis.

Figure 75 - Fiber-optic Cable Example - Two Logix5000 Controllers

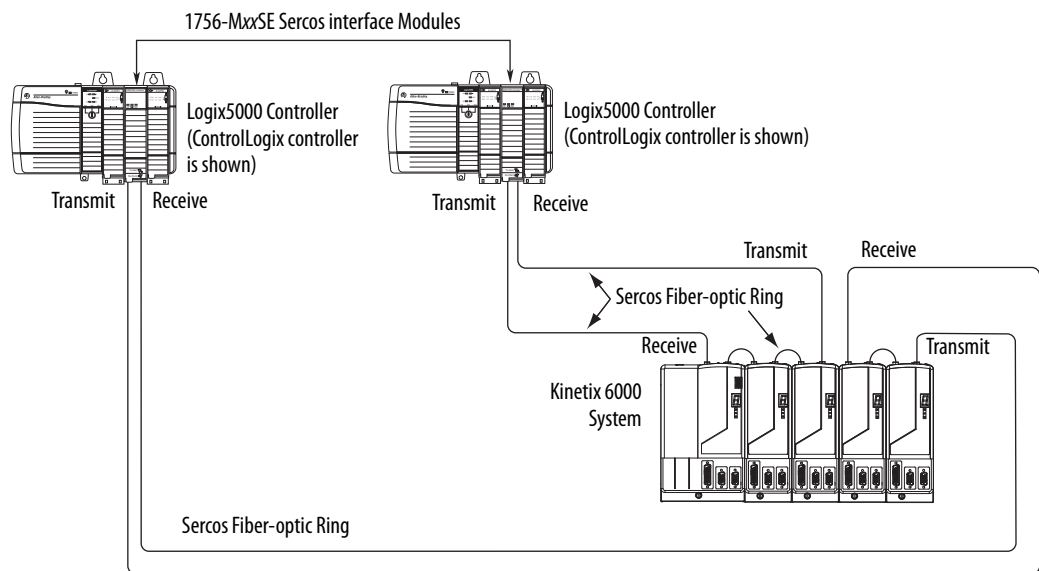

IMPORTANT Clean the fiber-optic cable connectors prior to installation. Dust in the connectors can reduce signal strength. For more information, refer to Fiber-optic Cable Installation and Handling Instructions, publication [2090-IN010](#).

When connecting 2094-BM03-*x* and 2094-BM05-*x* (double-wide) axis modules, use 2090-SCEP0-2, 0.2 m (7.0 in.) cables. When connecting 2094-AM xx -*x*, 2094-BMP5-*x*, 2094-BM01-*x*, and 2094-BM02-*x* (single-wide) axis modules, use 2090-SCEP0-1, 0.1 m (5.1 in.) cables.

Figure 76 - Fiber-optic Cable Example - Logix5000 Controller with Double-wide Drive Modules

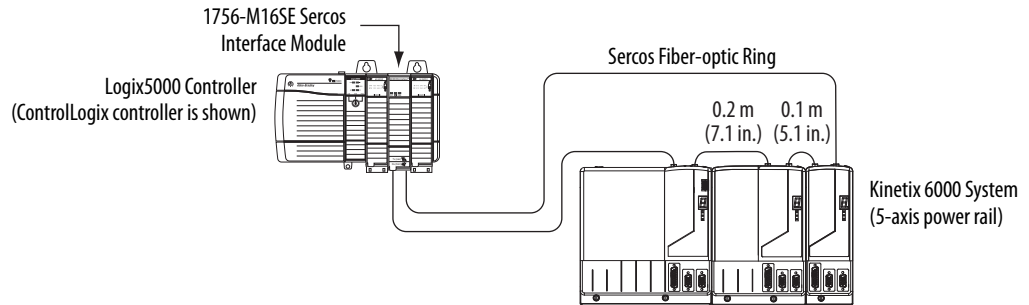

In this example, the second Kinetix 6000 system is mounted in a separate cabinet and connected with bulkhead adapters.

IMPORTANT To avoid signal loss, do not use bulkhead adapters to connect glass cables. Use only bulkhead adapters for making plastic-to-plastic cable connections.

Figure 77 - Fiber-optic Cable Example - Logix5000 Controller with Bulkhead Adapters

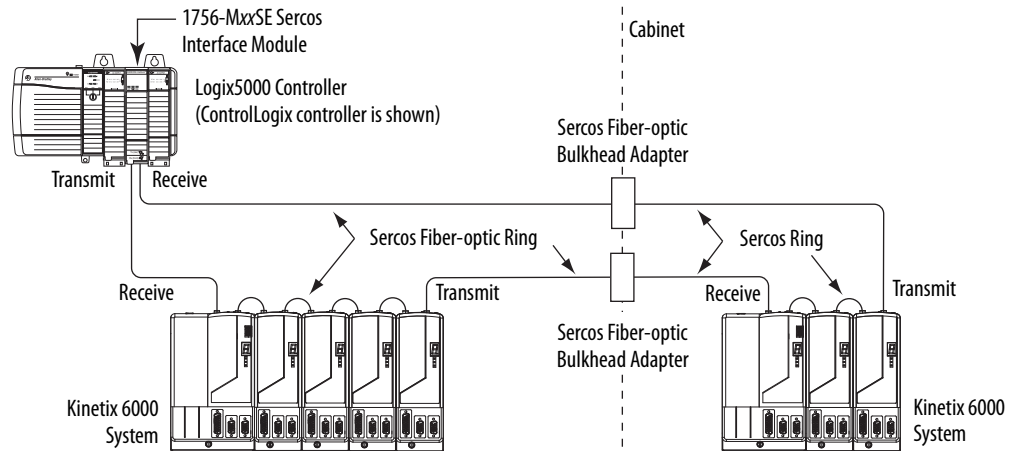

Kinetix 6000M Integrated Drive-Motor Sercos Connections

The Kinetix 6000 sercos ring includes the Kinetix 6000M integrated drive-motor (IDM) units and IDM power interface modules (IPIM). Fiber-optic connections are made from drive-to-drive and drive-to-IPIM module. IDM network connections continue from the IPIM module to the IDM units.

Because the Kinetix 6000M (IPIM) module has fiber-optic cable connectors positioned identical to the Kinetix 6000 (2094-BM xx -S) drives, the IPIM module uses the same fiber-optic cable lengths as the drive modules.

Figure 78 - Fiber-optic Cable Example - Logix5000 Controller with Kinetix 6000M (IPIM) Module

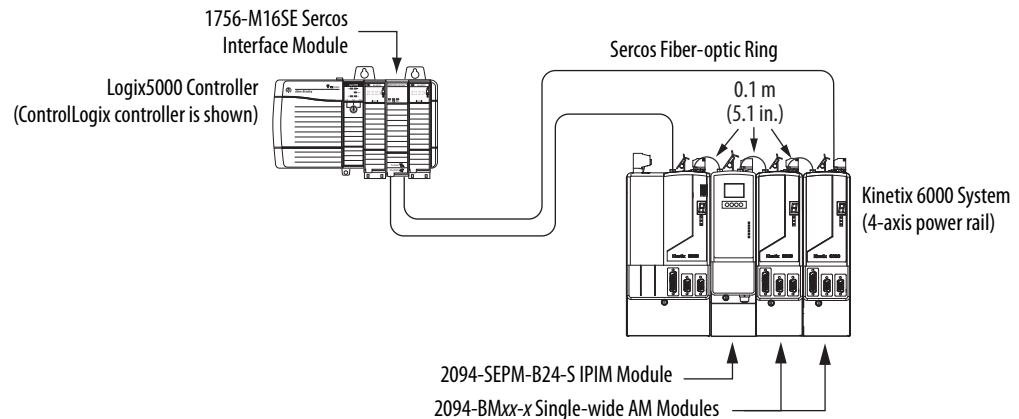

In this example, all the drive modules and the IPIM module are on the same sercos ring. The ring begins and ends at the 1756-M16SE sercos module. IDM units (not shown for simplicity) connected to the IPIM module, are also part of this sercos ring.

For more Kinetix 6000 IDM system examples including the IDM units, refer to the Kinetix 6000M Integrated Drive-Motor System User Manual, publication [2094-UM003](#).

Ethernet Cable Connections

This procedure assumes you have your ControlLogix or CompactLogix EtherNet/IP module and Bulletin 2094 control modules mounted and are ready to connect the Ethernet network cables.

The EtherNet/IP network is connected by using the PORT 1 and/or PORT 2 connectors.

Table 94 - EtherNet/IP Connector Location

Drive Family	Cat. No.	EtherNet/IP Network	Refer to
Kinetix 6000M	2094-SEPM-B24-S	Monitoring, diagnostics, and firmware upgrades	page 59

Figure 79 - ControlLogix and CompactLogix Ethernet Port Locations

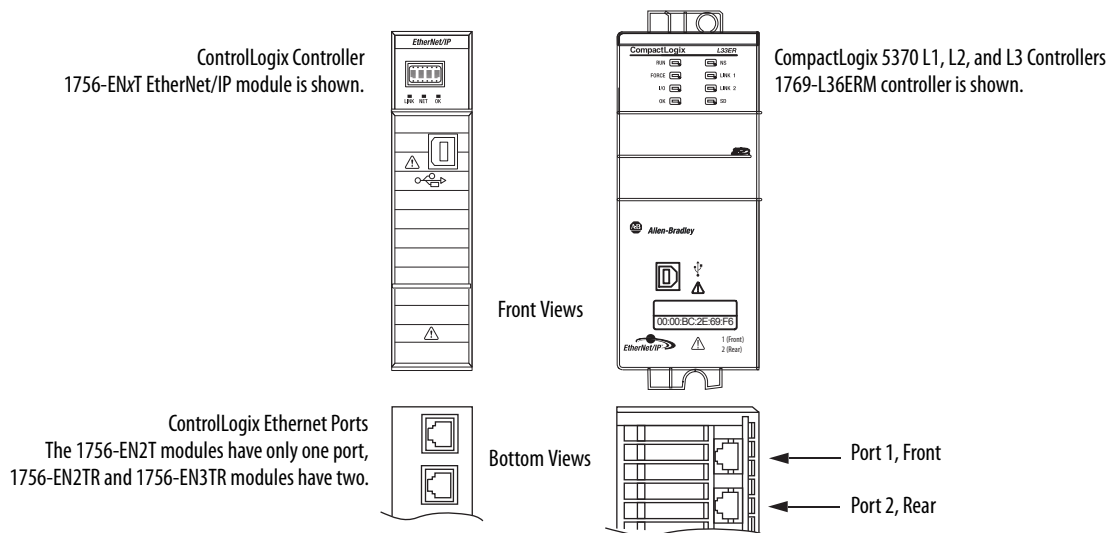

Configure and Start the Kinetix 6000 Drive System

This chapter provides procedures for configuring your Kinetix 6000 system components with your Logix sercos module.

Topic	Page
Configure the Kinetix 6000M Integrated Drive-Motor System	133
Configure the Drive Modules	134
Configure the Logix5000 Sercos interface Module	140
Apply Power to the Kinetix 6000 Drive	153
Test and Tune the Axes	155
Configure Drive Parameters and System Variables	160

TIP Before you begin, make sure you know the catalog number for each drive component, the Logix5000 module, and the servo motor/actuator in your motion control application.

Configure the Kinetix 6000M Integrated Drive-Motor System

Configuration for the Kinetix 6000M integrated drive-motor (IDM) system follows a procedure similar to what is described in this chapter. You'll assign each IDM unit a node address and configure the IDM system in the Logix Designer application.

The IPIM module does not require configuration for your IDM units to be configured in the sercos ring. However, you can include the IPIM module in your project by connecting it to a configured Ethernet module in the Logix5000 chassis and adding it under the Ethernet module in the I/O configuration tree. An Add-On Profile is also needed to use the IPIM module in the project, but as a result you can view IPIM module status information in the configuration software and use it in your application program. The Ethernet connection is also used to upgrade the IPIM module firmware by using ControlFLASH software.

For system configuration and startup procedures specific to the IDM system, refer to the Kinetix 6000M Integrated Drive-Motor System User Manual, publication [2094-UM003](#).

Configure the Drive Modules

Follow these steps to configure the integrated axis module (IAM) and axis modules (AM).

IMPORTANT If you have one or more IDM power interface modules (IPIM) on your power rail, refer to the Kinetix 6000M Integrated Drive-Motor System User Manual, publication [2094-UM003](#), for system configuration information specific to the Kinetix 6000M IDM system.

1. Verify that no power is applied to the IAM and AM modules and that the communication cables are plugged into the appropriate connectors.

To verify communication, refer to Sercos Fiber-optic Cable Connections on [page 128](#).

To Configure	Begin With
The IAM module	step 2
Any AM module	step 4
Kinetix 6000M IDM system ⁽¹⁾	Kinetix 6000M Integrated Drive-Motor User Manual, publication 2094-UM003 .

(1) Sercos fiber-optic cable connections for the Kinetix 6000M integrated drive-motor (IDM) system are on [page 131](#).

2. Set the base node address for the IAM module by setting the Node Address switches.

Valid node addresses for sercos communication are 01...99. The left switch sets the most significant digit (MSD) and the right switch sets the least significant digit (LSD).

To	Press
Increment the (MSD/LSD) node address	The plus (+) switch.
Decrement the (MSD/LSD) node address	The minus (-) switch.

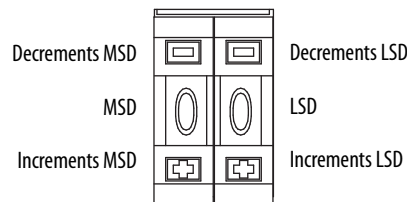

Setting the base node address on the IAM module determines the node address for the IAM (inverter) module. Node addressing for all slot locations on the same power rail increment (from the IAM inverter) left to right.

3. Cycle control power to initialize the IAM module.

IMPORTANT The base node address setting takes effect only after the IAM module is initialized.

IMPORTANT When two or more IAM modules are connected to the same sercos interface module, each node address must be unique.
Refer to the node addressing examples beginning on [page 136](#).

4. Set the sercos communication rate with DIP switches 2 and 3.

For This Communication Rate	Set Switch 2	Set Switch 3
4 Mbps	OFF	ON
8 Mbps ⁽¹⁾	ON	OFF

(1) The Kinetix 6000M IDM system supports only 8 Mbps and is hardwired for this setting.

5. Set the sercos optical power level to High with DIP switch 1.

For This Optical Power Level	Set Switch 1
Low	OFF
High	ON

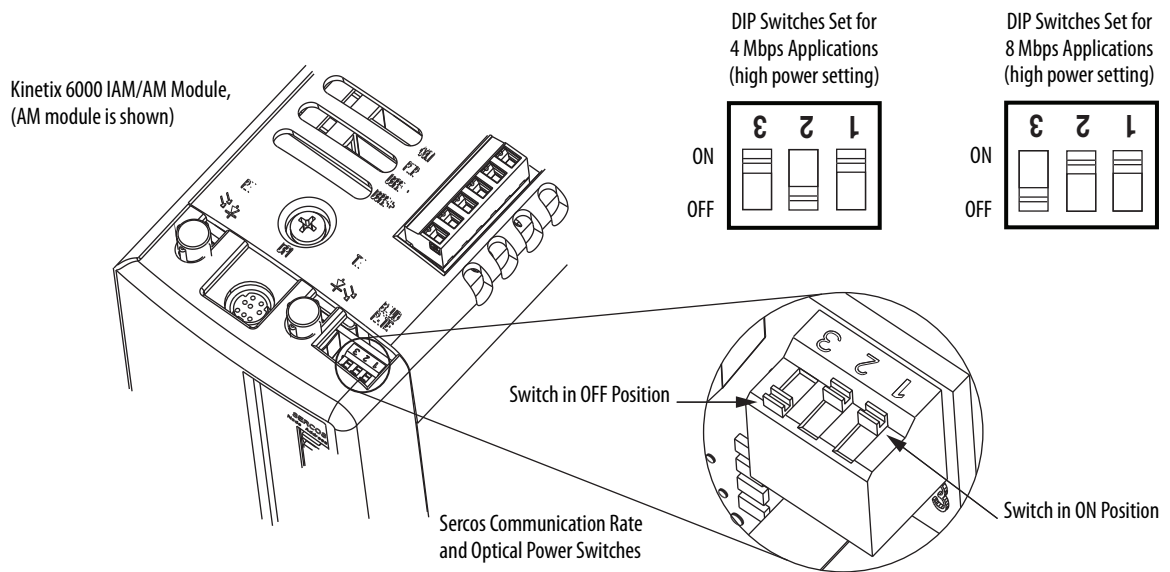

6. Repeat [step 4](#) and [step 5](#) for each 2094-xMxx-x AM module.

Figure 80 - Node Addressing Example 1

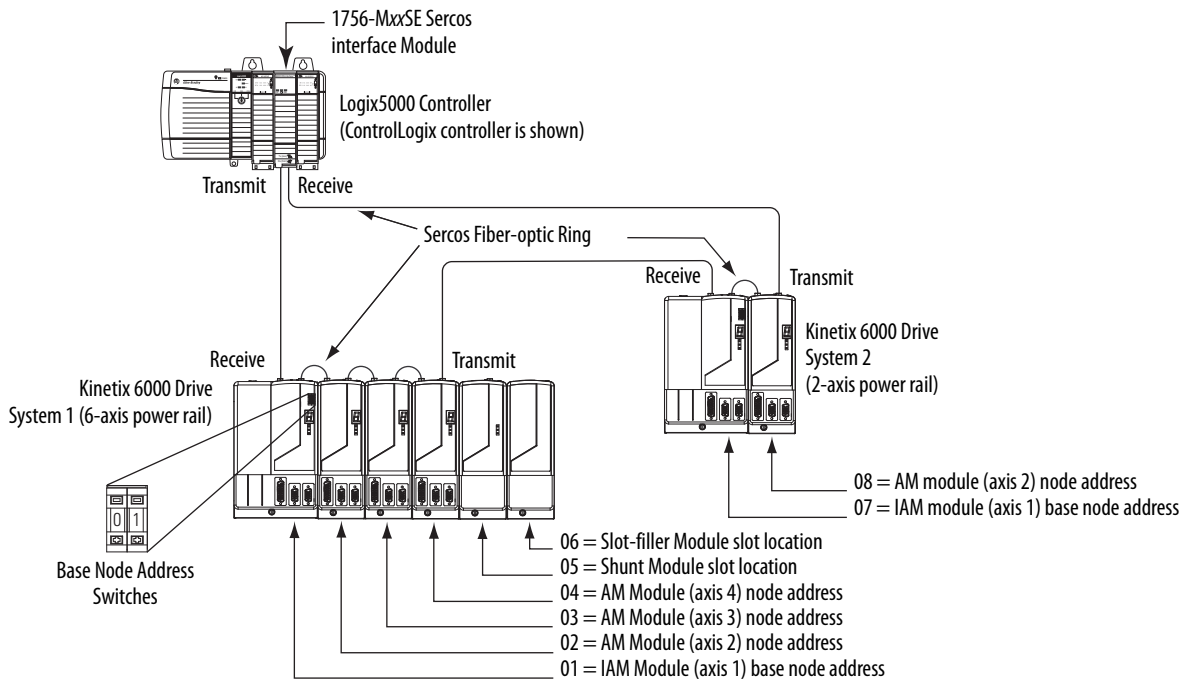

In Example 1, the Kinetix 6000 (6-axis) drive system 1 power rail contains one IAM module, three AM modules, one shunt module, and one slot-filler module. The shunt module and slot-filler modules are not assigned a sercos node address, but the system identifies them with a slot location.

Kinetix 6000 (2-axis) drive system 2 power rail contains one IAM module and one AM module. The base node address of the (system 2) IAM module must be set for an address of ≥ 007 .

IMPORTANT The node address for each axis module is determined by the base node-address switch setting on the IAM module.

Do not position axis modules to the right of shunt or slot-filler modules. The added distance between non-adjacent axes can increase electrical noise and impedance, and requires longer fiber-optic cable lengths.

IMPORTANT Slot-filler modules must be used to fill any unoccupied slot on the power rail. However, you can replace slot-filler modules with AM modules or the 2094-BSP2 shunt module (maximum one 2094-BSP2 shunt module per power rail).

Figure 81 - Node Addressing Example 2

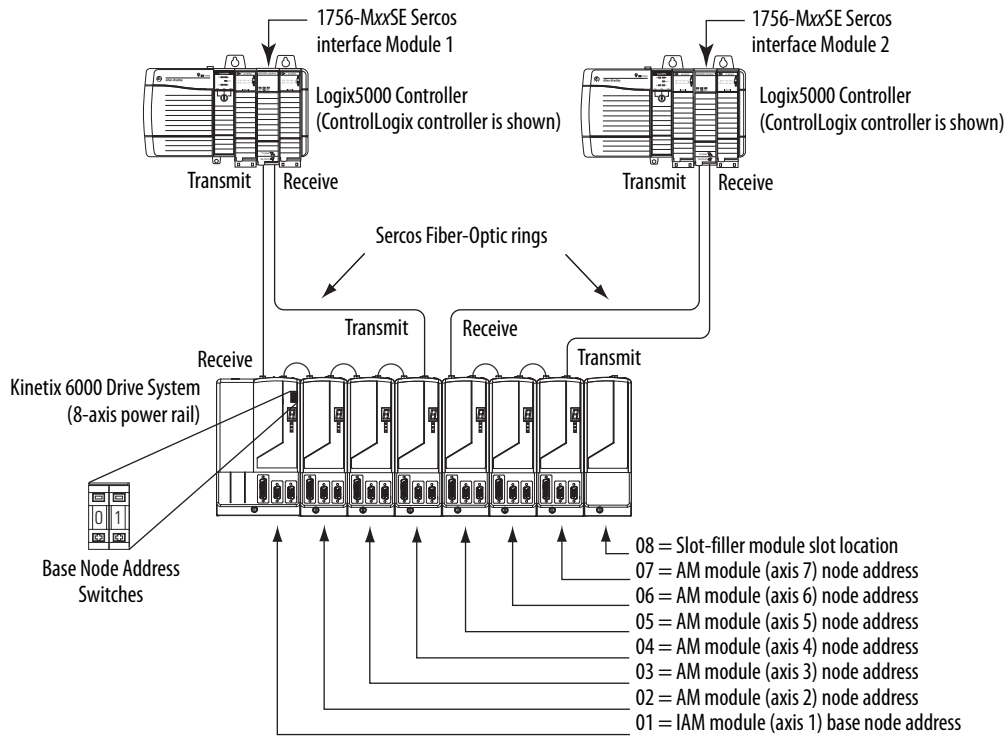

In this example, sercos interface module 1 controls axes 1...4 and module 2 controls axes 5...7. The slot-filler module is not assigned a sercos node address, but the system identifies it with a slot location.

You can mount the two sercos interface modules in two separate ControlLogix chassis (as shown) or you can mount them in the same chassis.

IMPORTANT The node address for each axis module is determined by the base node-address switch setting on the IAM module.

Do not position axis modules to the right of shunt or slot-filler modules. The added distance between non-adjacent axes can increase electrical noise and impedance, and requires longer fiber-optic cable lengths.

IMPORTANT Slot-filler modules must be used to fill any unoccupied slot on the power rail. However, you can replace slot-filler modules with AM modules or the 2094-BSP2 shunt module (maximum one 2094-BSP2 shunt module per power rail).

Figure 82 - Node Addressing Example 3

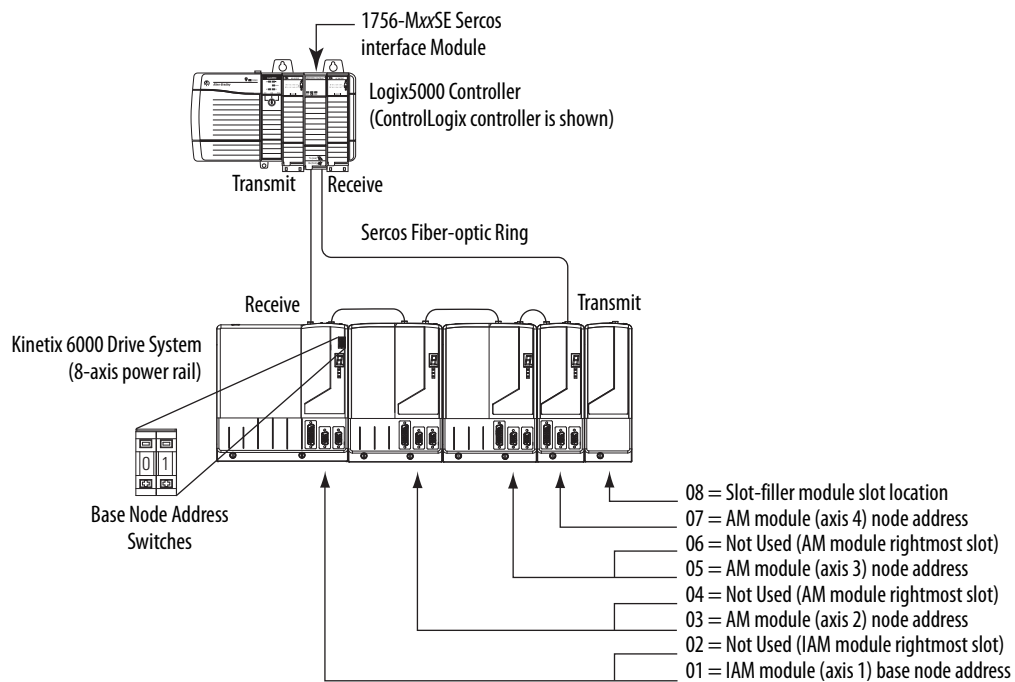

In this example, the Kinetix 6000 (8-axis) power rail contains a double-wide IAM module, two double-wide AM modules, one single-wide AM module, and one slot-filler module. The slot-filler module is not assigned a sercos node address, but the system identifies it with a slot location.

The leftmost slot of a double-wide module determines the node address. So, in the example above, node addresses 02, 04, and 06 (the rightmost slots of the double-wide modules) are not used.

IMPORTANT The node address for each axis module is determined by the base node-address switch setting on the IAM module.

Do not position axis modules to the right of shunt or slot-filler modules. The added distance between non-adjacent axes can increase electrical noise and impedance, and requires longer fiber-optic cable lengths.

IMPORTANT Slot-filler modules must be used to fill any unoccupied slot on the power rail. However, you can replace slot-filler modules with AM modules or the 2094-BSP2 shunt module (maximum one 2094-BSP2 shunt module per power rail).

Figure 83 - Node Addressing Example 4

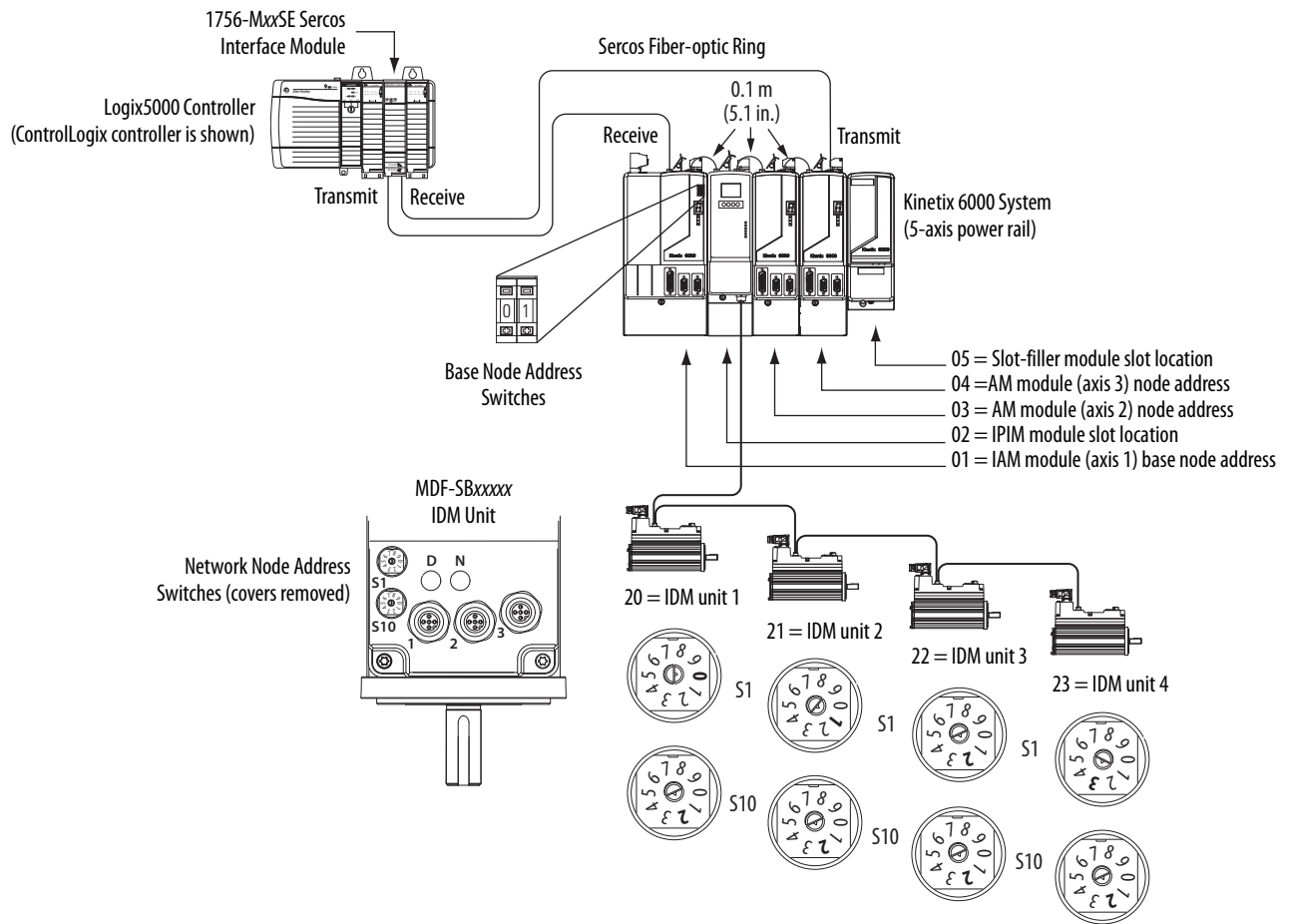

In this example, the Kinetix 6000 (5-axis) power rail contains two single-wide axis modules and one IDM system. Neither the slot-filler or IPIM module is assigned a sercos node address, but the system identifies them with a slot location.

Node addressing on the power rail is no different than the previous examples. Node address 02 and 05 are available for any of the IDM units, but to avoid confusion, the node addressing for the IDM units was started at 20. Unlike the axis modules, each IDM unit has switches that determine its node address. In this example, the IDM unit node addressing is sequential, but it doesn't have to be.

IMPORTANT Creating a duplicate node address between the axis modules mounted on the power rail and the IDM system (in the same sercos ring) generates error code E50. Each node address on the sercos ring must be unique within the range of 01...99. Axes on the same power rail as the IPIM module do not have to be in the same sercos ring as the IDM units.

IMPORTANT Slot-filler modules must be used to fill any unoccupied slot on the power rail. However, you can replace slot-filler modules with AM modules or the 2094-BSP2 shunt module (maximum one 2094-BSP2 shunt module per power rail).

Configure the Logix5000 Sercos interface Module

This procedure assumes that you have wired your Kinetix 6000 system and have configured the communication rate and optical power switches.

For help with using the Logix Designer application as it applies to configuring the ControlLogix, CompactLogix, or SoftLogix sercos modules, refer to Additional Resources on [page 12](#).

Configure the Logix5000 Controller

Follow these steps to configure the Logix5000 controller.

1. Apply power to your Logix5000 chassis containing the sercos interface module/PCI card and open your Logix Designer application.
2. From the File menu, choose New.

The New Controller dialog box opens.

3. Configure the new controller.
 - a. From the Type pull-down menu, choose the controller type.
 - b. From the Revision pull-down menu, choose the revision.
 - c. Type the file Name.
 - d. From the Chassis Type pull-down menu, choose the chassis.
 - e. Enter the Logix5000 processor slot.
4. Click OK.
5. From the Edit menu, choose Controller Properties.

The Controller Properties dialog box opens.

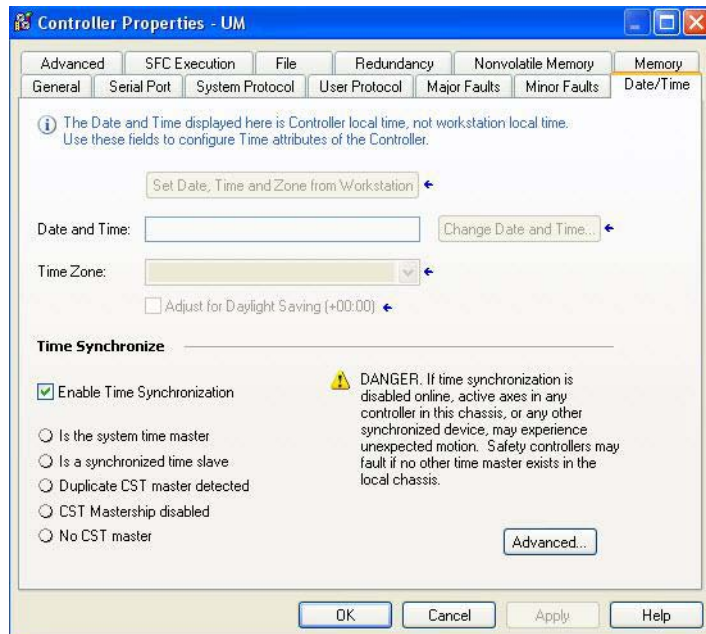

6. Click the Date/Time tab.
7. Check Enable Time Synchronization.

This assigns the controller as the Grandmaster clock. The motion modules set their clocks to the module you assign as the Grandmaster.

IMPORTANT You can assign only one module in the Logix5000 chassis as the Grandmaster clock.

8. Click OK.

Configure the Logix5000 Module

Follow these steps to configure the Logix5000 module.

1. Right-click I/O Configuration in the Controller Organizer and choose New Module.

The Select Module dialog box opens.

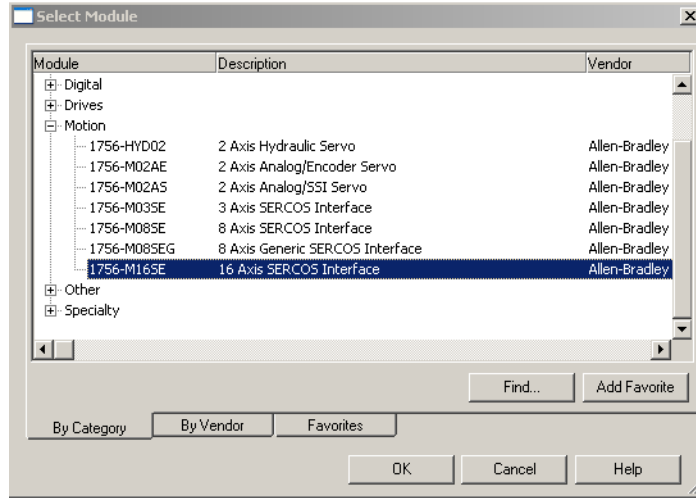

2. Expand the Motion category and select 1756-MxxSE, 1756-L60M03SE, 1768-M04SE, or 1784-PM16SE as appropriate for your actual hardware configuration.

In this example, the 1756-M16SE module is selected.

3. Click OK.

The New Module dialog box opens.

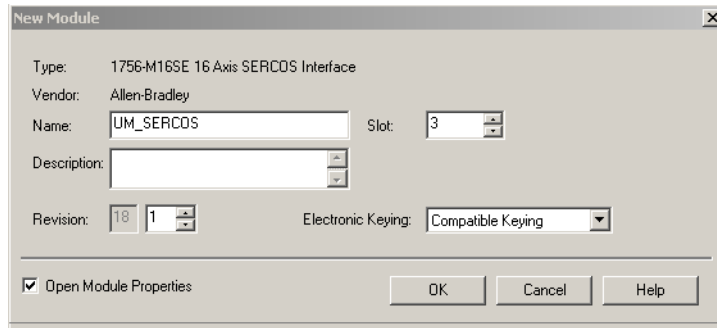

4. Configure the new module.
 - a. Type the module Name.
 - b. Enter the Logix5000 sercos module slot (leftmost slot = 0).
 - c. Check Open Module Properties.
5. Click OK.

Your new module appears under the I/O Configuration folder in the Controller Organizer and the Module Properties dialog box opens.

6. Click the sercos Interface tab and reference the table below.

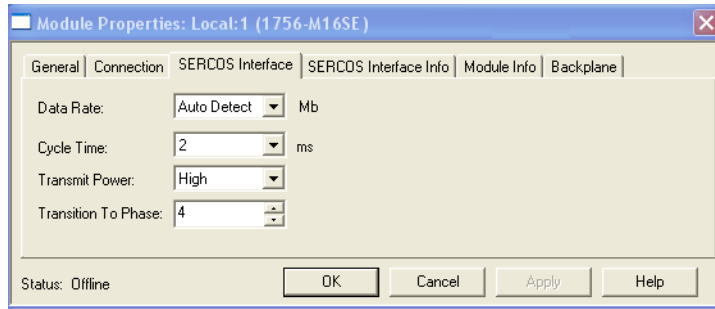

Logix5000 Sercos Module	Number of Axes	Data Rate
1756-M03SE or 1756-L60M03SE	Up to 3	4 or 8 Mbps
1756-M08SE	Up to 8	
1756-M16SE or 1784-PM16SE	Up to 16	
1768-M04SE	Up to 4	

- Verify that the Data Rate setting matches DIP switches 2 and 3 (communication rate), as set on the IAM and AM module, or choose the Auto Detect setting.
- From the Cycle Time pull-down menu, choose the Cycle Time according to the table below.

Data Rate	Number of Axes	Cycle Time
4 Mbps	Up to 2	0.5 ms
	Up to 4	1 ms
	Up to 8	2 ms
	No support for axes 9...16	
8 Mbps ⁽¹⁾	Up to 4	0.5 ms
	Up to 8	1 ms
	Up to 16	2 ms

(1) The Kinetix 6000M IDM system supports only 8 Mbps and is hardwired for this setting.

TIP The number of axes/module is limited to the number of axes as shown in [step 6](#).

- From the Transmit Power pull-down menu, choose High.
The default setting is High, however this setting is dependent on the cable length (distance to next receiver) and cable type (glass or plastic).
- Enter the Transition to Phase setting.
The Transition to Phase default setting is 4 (phase 4). The Transition to Phase setting stops the ring in the phase specified.
- Click OK.
- Repeat [step 1](#) through [step 11](#) for each Logix5000 module.

Configure the Kinetix 6000 Drive Modules

Follow these steps to configure the Kinetix 6000 drive modules.

1. Right-click the Logix5000 module you just created and choose New Module.

The Select Module dialog box opens.

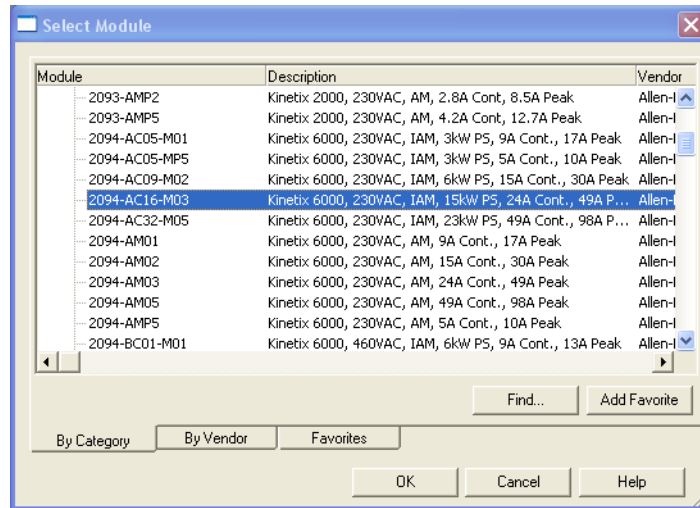

2. Expand the Drives category and select drive components appropriate for your actual hardware configuration.

IMPORTANT In order for the Kinetix 6000 drive to communicate with the sercos interface module (indicated by three solid-green status indicators on the sercos module), you must be using RSLogix 5000 software, version 11.00 or later, or the Logix Designer application.

3. Click OK.

The New Module dialog box opens.

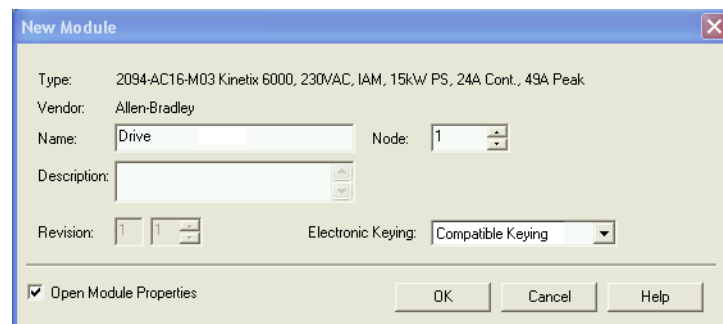

4. Configure the new module.
 - a. Type the module Name.
 - b. Enter the Node address.

Set the node address in the software to match the node setting on the drive. Refer to Configure the Drive Modules, [step 2](#), on [page 134](#).

- c. Check Open Module Properties.
5. Click OK.
6. Click the Associated Axes tab.

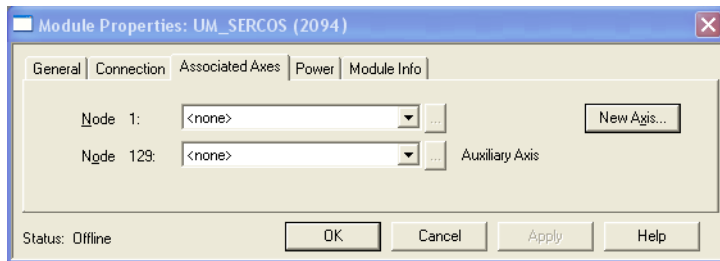

7. Click New Axis.

The New Tag dialog box opens.

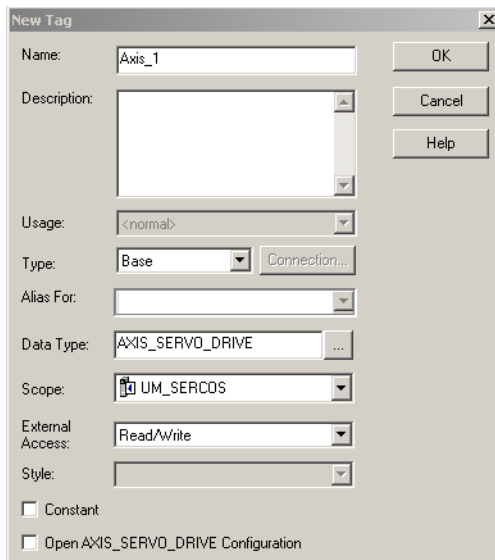

8. Type the axis Name.
 AXIS_SERVO_DRIVE is the default Data Type.
9. Click OK.

The axis appears under the Ungrouped Axes folder in the Controller Organizer.

10. Assign your axis to Node 1.

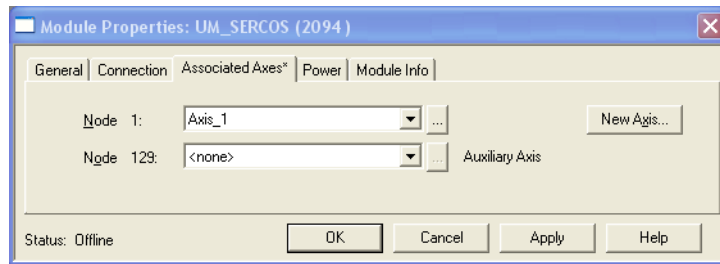

11. Click Apply.

TIP With drive firmware revision 1.80 or later, and the Logix Designer application or RSLogix 5000 software, version 13 or later, it is possible to configure the Auxiliary Axis feedback port as a Feedback Only axis. With this feature, you can configure each IAM inverter or AM module to appear as two axes/nodes on the sercos ring. The base node is the servo axis using the motor feedback, and the base node (plus 128) is a feedback-only axis that uses the auxiliary feedback port.

Auxiliary feedback is not supported by the Kinetix 6000M IDM units.

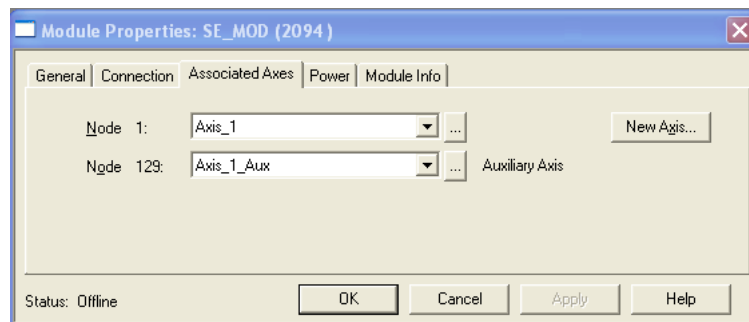

The Auxiliary Axis (Node 129) is configured identical to Node 1 by clicking New Axis and creating a new tag.

12. Click Apply if you made changes.

13. Click the Power tab.

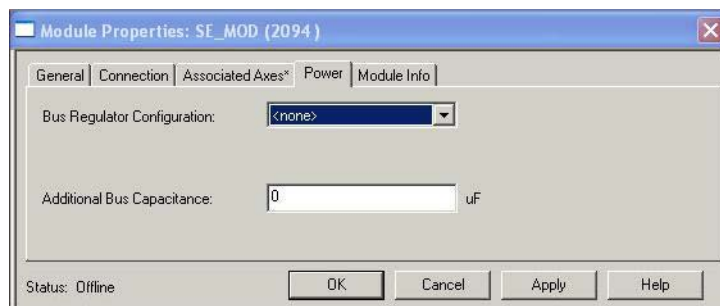

14. From the Bus Regulator Catalog Number pull-down menu, choose the shunt option appropriate for your actual hardware configuration.

If your IAM module is	And your hardware configuration includes this shunt option	Then choose
Configured as an IAM module or common-bus leader IAM module ⁽¹⁾	Internal shunt resistors only	Internal or <none>
	Bulletin 2094 (rail mounted) shunt module	2094-BSP2
	Bulletin 1394 passive shunt module (connected to the 2094-BSP2 shunt module)	1394-SRxxxx
	External active shunt module	Internal or <none>
Configured as a common-bus follower IAM module ⁽²⁾	N/A. Shunts are disabled on follower IAM module	CommonBus Follow

(1) Drive does not accept Internal, <none>, 2094-BSP2, or 1394-SRxxxx selection if DC bus voltage is present without having three-phase power applied.
 (2) Drive does not accept CommonBus Follow selection if three-phase power or DC bus power is applied.



To avoid damage to your Bulletin 1394 external shunt module when wired to the 2094-BSP2 shunt module, verify that the proper 230V or 460V fuse is installed prior to applying power.

Refer to Kinetix Motion Accessories Specifications Technical Data, publication [GMC-TD004](#), for more information.

IMPORTANT When configured to use the Bulletin 1394 or 2094 shunt modules, the IAM bus regulator capacity attribute displays the utilization of total shunt power available (as a percent) based on the power rail configuration.
 Refer to Kinetix Motion Accessories Specifications Technical Data, publication [GMC-TD004](#), for shunt power specification and examples.

15. Calculate additional bus capacitance, if this applies to your application, and enter the value here (version 20.00 or later), or refer to [Appendix E](#) on [page 249](#) to set the Add Bus Cap parameter.

The Additional Bus Capacitance field applies only to the IAM module.

IMPORTANT DC common-bus applications must calculate Total Bus Capacitance and Additional Bus Capacitance and set the Add Bus Cap parameter in the leader IAM module. However, you can set the parameter as shown in [step 15](#) or by using DriveExplorer software or the Logix Designer application, as shown in [Appendix E](#).
 Refer to [Appendix C](#) beginning on [page 225](#), for more information on making the calculations. Refer to [Appendix E](#) beginning on [page 249](#), for more information on setting the Add Bus Cap parameter.

16. Click OK.
 17. Repeat [step 1](#) through [step 10](#) for each Bulletin 2094 AM module and each IDM unit.

Configure the Motion Group

Follow these steps to configure the motion group.

1. Right-click Motion Groups in the Controller Organizer and choose New Motion Group.

The New Tag dialog box opens.

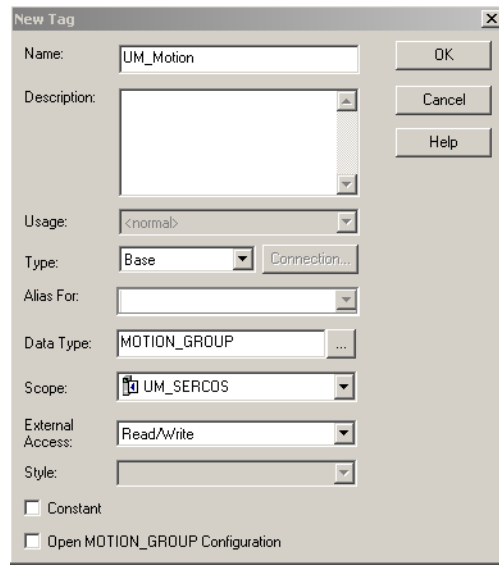

2. Type the new motion group Name.
3. Click OK.

The new motion group appears under the Motion Groups folder.

4. Right-click the new motion group and choose Properties.

The Motion Group Properties dialog box opens.

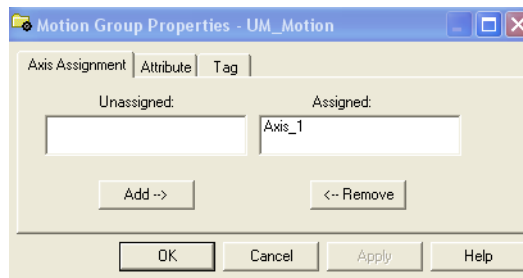

5. Click the Axis Assignment tab and move your axes (created earlier) from Unassigned to Assigned.
6. Click the Attribute tab and edit the default values as appropriate for your application.
7. Click OK.

Configure Axis Properties

The peak current ratings of the Kinetix 6000 AM modules (series A, B, and C) are configured at the factory as 150% of continuous current. You can program 460V (series B and C) AM modules and the equivalent IAM (inverter) modules, for up to 250% of continuous inverter current.

Refer to [Appendix F](#) on [page 255](#) to recalculate torque and acceleration or deceleration limit values, and paste them into the appropriate Axis Properties dialog box in the Logix Designer application.

Follow these steps to configure Axis properties for motor feedback.

1. Right-click an axis in the Controller Organizer and choose Properties.

The Axis Properties dialog box opens.

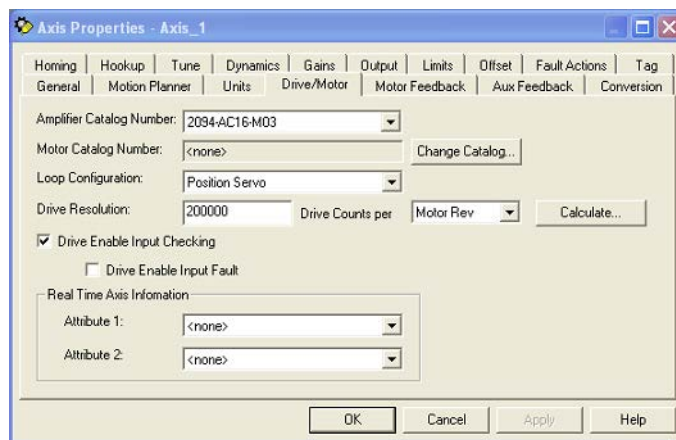

2. Click the Drive/Motor tab.
3. Click Change Catalog.

The Change Catalog Number dialog box opens.

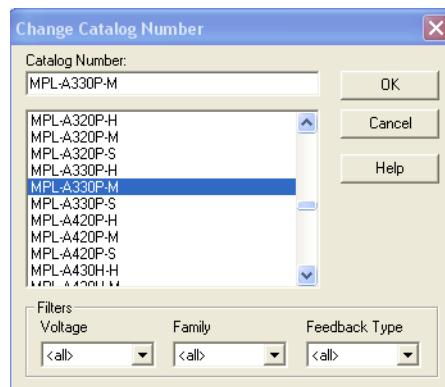

4. Select the motor catalog number appropriate for your application.
To verify the motor catalog number, refer to the motor name plate.
5. Click OK.

6. On the Drive/Motor tab, check Drive Enable Input Checking.
When checked (default), means a hard drive-enable input signal is required. Uncheck to remove that requirement.
7. Click Apply.
8. Click the Motor Feedback tab and verify the Feedback Type shown is appropriate for your actual hardware configuration.
9. Click the Units tab and edit default values as appropriate for your application.
10. Click the Conversion tab and edit default values as appropriate for your application.

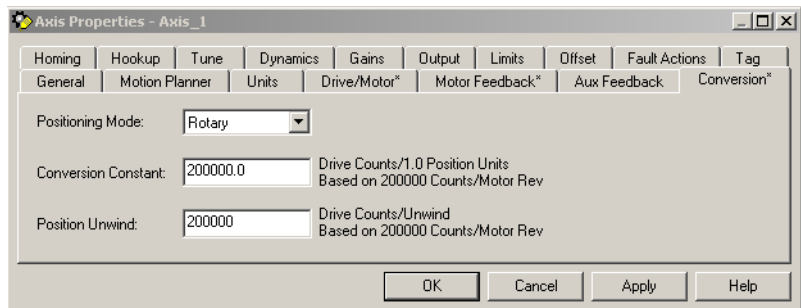

In this example, Rotary is chosen from the Positioning Mode pull-down menu.

11. Click Apply if you made changes.
12. Click the Fault Actions tab.

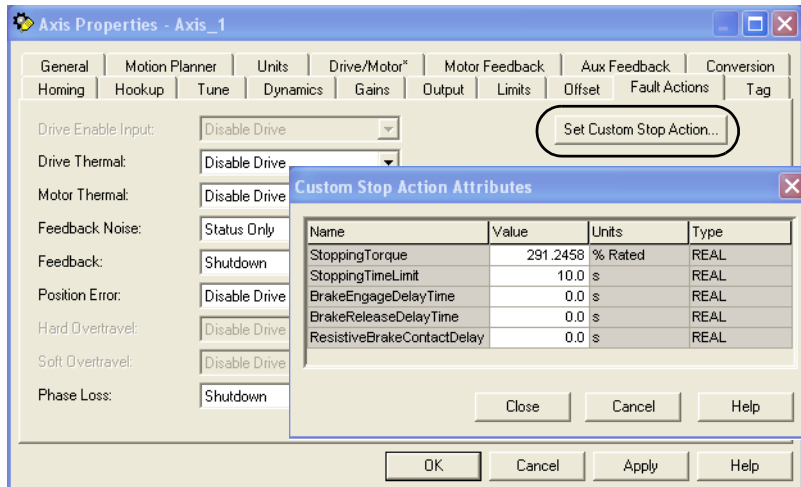

13. Click Set Custom Stop Action.

The Custom Stop Action Attributes dialog box opens and lets you set delay times for servo motors and RBM modules.

14. Configure the delay times.
 - a. Type the Brake Engage Delay Time.
 - b. Type the Brake Release Delay Time.
 - c. Set the Resistive Brake Contact Delay time (0 - 1000 ms range).

TIP For recommended motor brake response times, refer to the Kinetix Rotary Motion Technical Data, publication [GMC-TD001](#).
The recommended delay time for 2090-XB33-xx and 2090-XB120-xx RBM modules is 71 ms.

- d. Click Close to close the Custom Stop Action Attributes dialog box.
15. Click Apply.
16. Repeat [step 1](#) through [step 15](#) for each Bulletin 2094 AM module.

Follow these steps to configure Auxiliary Axis properties.

IMPORTANT Auxiliary feedback is not supported by the Kinetix 6000M IDM units.

1. Right-click an auxiliary axis in the Controller Organizer and choose Properties.

The Axis Properties dialog box opens on the General tab.

If an axis is associated to the auxiliary axis node, set the Axis Configuration on the General tab of the Axis Properties dialog box to Feedback Only.

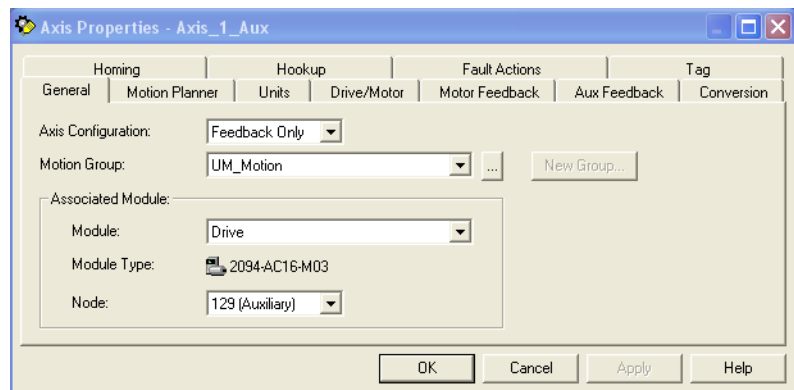

2. Click the Drive/Motor tab.

The Drive/Motor tab displays the amplifier being used and the Loop Configuration is Aux Feedback Only. This is the only choice if the amplifier is using the primary node for Servo (motor) configuration.

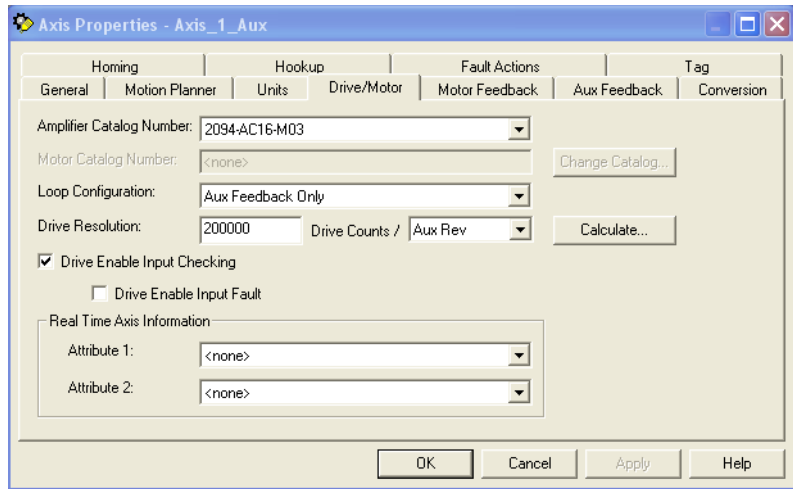

3. Click the Aux Feedback tab.

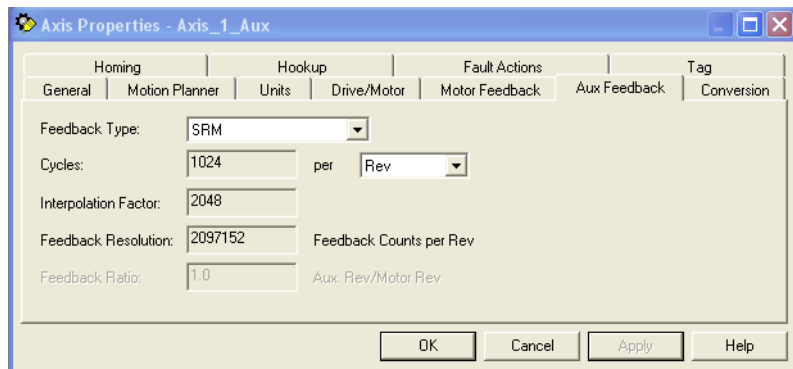

IMPORTANT The Aux Feedback tab must be configured for the auxiliary feedback type being used. In this example, an SRM feedback device is being used.

4. From the Feedback Type pull-down menu, choose the feedback type appropriate for your auxiliary feedback motor.
5. Click OK.
6. Verify your Logix5000 program and save the file.

Download the Program

After completing the Logix5000 configuration you must download your program to the Logix5000 processor.

Apply Power to the Kinetix 6000 Drive

This procedure assumes that you have wired and configured your Kinetix 6000 system (with or without the LIM module) and your sercos interface module.



ATTENTION: Capacitors on the DC bus can retain hazardous voltages after input power has been removed. Before working on the drive, measure the DC bus voltage to verify it has reached a safe level or wait the full time interval as indicated in the warning on the front of the drive. Failure to observe this precaution could result in severe bodily injury or loss of life.

Refer to the Line Interface Module Installation Instructions, publication [2094-IN005](#), when troubleshooting the LIM module status indicators, and for the location of LIM module circuit breakers, connectors, and status indicators.

Refer to the Kinetix 6000M Integrated Drive-Motor System User Manual, publication [2094-UM003](#), for connector locations and when troubleshooting the IPIM module and IDM unit status indicators.

Follow these steps to apply power to the Kinetix 6000 drive system.

1. Disconnect the load to the motor.



ATTENTION: To avoid personal injury or damage to equipment, disconnect the load to the motor. Make sure each motor is free of all linkages when initially applying power to the system.

2. Determine your source of control power.

If Your Control Power	Then
Is sourced from a LIM module	<ol style="list-style-type: none"> 1. Verify that CB1, CB2, and CB3 are in the OFF position. 2. Apply three-phase input power to the LIM module VAC Line connector. 3. Set CB3 to the ON position. 4. Set CB2 to the ON position. 5. Go to main step 3.
Is not sourced from a LIM module	<ol style="list-style-type: none"> 1. Apply (95...264V AC) control power to the IAM module (CPD connector). 2. Go to main step 3.

3. Observe the IAM/AM module logic power status indicator.

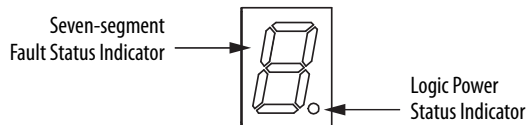

If the Logic Power Indicator is ⁽¹⁾	Then
ON	Go to step 4 .
Not ON	<ol style="list-style-type: none"> 1. Check your control power connections. 2. Go back to main step 2.

(1) If your 2094 drive system includes a Kinetix 6000M IDM system, observe the drive status indicator and verify that it is on.

4. Determine your source of three-phase input power.

If Your Three-phase Power	Then
Is sourced from a LIM module	<ol style="list-style-type: none"> 1. Set CB1 to the ON position. 2. Verify the Hardware Enable Input signal (IOD-2) for each axis is at 0 volts. Remove the connection between IOD-1 and IOD-2 if one exists. ⁽¹⁾ 3. Go to main step 5.
Is not sourced from a LIM module	<ol style="list-style-type: none"> 1. Apply 195...265V AC (230V) or 324...528V AC (460V) input power to the IAM module (IPD connector). 2. Verify the Hardware Enable Input signal (IOD-2) for each axis is at 0 volts. Remove the connection between IOD-1 and IOD-2 if one exists. ⁽¹⁾ 3. Go to main step 5.

(1) The hardware enable input for IDM units is on the IPIM module.

5. Observe the IAM/AM module fault status indicator.

The status indicator first flashes the sercos node address, then cycles through ring phases until final configuration (phase 4) is reached.

IAM/AM Fault Status Indicator	Status	Do This
Actively cycling (phase 0)	The drive is looking for a closed sercos ring. Wait for phase 1 or take corrective action until you reach phase 1.	Check fiber-optic connections.
Displaying a fixed 1 (phase 1)	The drive is looking for active nodes. Wait for phase 2 or take corrective action until you reach phase 2.	Check node addressing.
Displaying a fixed 2 (phase 2)	The drive is configuring nodes for communication. Wait for phase 3 or take corrective action until you reach phase 3.	Check program motor and drive configuration against installed hardware.
Displaying a fixed 3 (phase 3)	The drive is configuring device specific parameters. Wait for phase 4 or take corrective action until you reach phase 4.	Check motor catalog number against selection. ⁽¹⁾
Displaying a fixed 4 (phase 4)	The drive is configured and active.	Go to step 6 .
Flashing an E followed by two numbers	Drive is faulted.	Go to Kinetix 6000 Drive System Error Codes on page 165 .

(1) You can get diagnostic information from the module by highlighting the module name in the Logix Designer application. A Pseudo Key Failure often indicates that the motor selection does not match the motor installed.

6. Observe the status indicators on the front of the IAM/AM module.

Refer to troubleshooting tables for the Drive, Comm, and Bus status indicators in IAM/AM Module Status Indicators on [page 170](#). Refer to the Kinetix 6000M Integrated Drive-Motor System User Manual, publication [2094-UM003](#), for IPIM module and IDM unit status indicator troubleshooting tables.

7. Observe the three sercos indicators on the Logix5000 sercos module.

Three Sercos Indicators	Status	Do This
Flashing green and red	Establishing communication	Wait for steady green on all three indicators.
Steady green	Communication ready	Go to Test and Tune the Axes on page 155 .
Not flashing green and red/ not steady green	Sercos module is faulted	Go to the appropriate Logix5000 manual for specific instructions and troubleshooting.

Test and Tune the Axes

These procedures assume that you have configured your Kinetix 6000 drive, your Logix5000 sercos interface module, and applied power to the system.

For help with using the Logix Designer application, as it applies to testing and tuning your axes with ControlLogix, CompactLogix, or SoftLogix sercos modules, refer to Additional Resources on [page 12](#).

Test the Axes

Follow these steps to test the axes.

1. Verify the load was removed from each axis.
2. Right-click an axis in your Motion Group folder and choose Properties.

The Axis Properties dialog box opens.

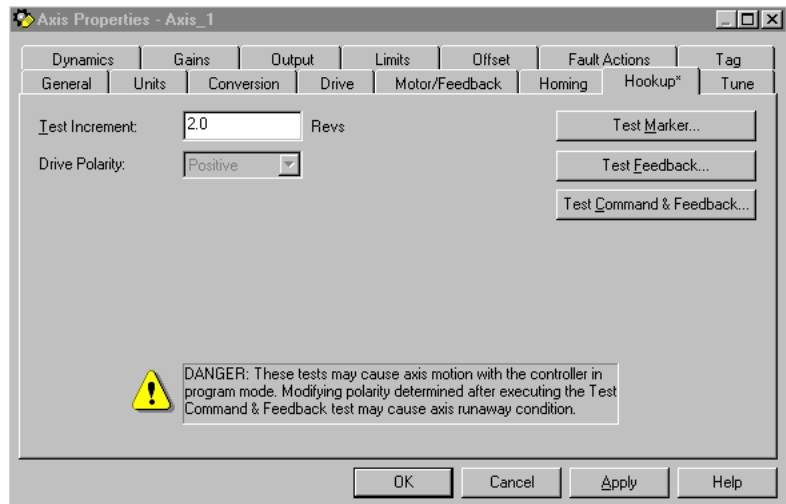

3. Click the Hookup tab.
4. Type 2.0 as the number of revolutions for the test or another number more appropriate for your application.

This Test	Performs this Test
Test Marker ⁽¹⁾	Verifies marker detection capability as you rotate the motor shaft.
Test Feedback ⁽¹⁾	Verifies feedback connections are wired correctly as you rotate the motor shaft. Also, lets you define polarity.
Test Command & Feedback	Verifies motor power and feedback connections are wired correctly as you command the motor to rotate. Also, lets you define polarity.

(1) If testing motor with brake, energize the brake circuit to release the brake prior to test.

5. Apply Hardware Enable Input signal (IOD-2) for the axis you are testing.



ATTENTION: To avoid personal injury or damage to equipment, apply 24V ENABLE signal (IOD-2) only to the axis you are testing.

IMPORTANT Hardware Enable input for IDM units is on the IPIM module.

- Click the desired test (Marker/Feedback/Command & Feedback) to verify connections.

The Online Command dialog box opens. Follow the on-screen test instructions. When the test completes, the Command Status changes from Executing to Command Complete.

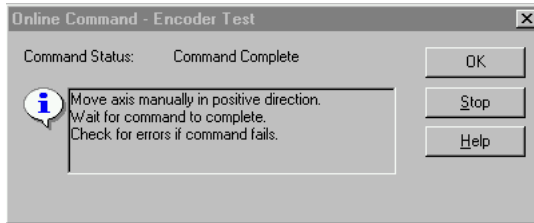

- Click OK.

The Online Command - Apply Test dialog box opens (Feedback and Command & Feedback tests only). When the test completes, the Command Status changes from Executing to Command Complete.

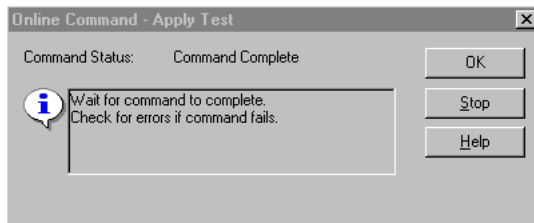

- Click OK.
- Determine if your test completed successfully.

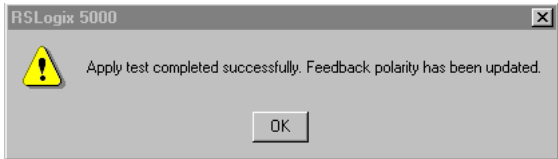
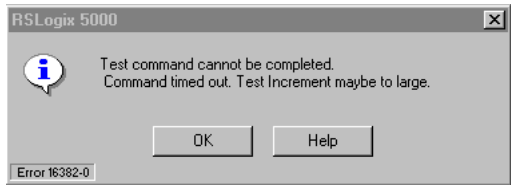
If	Then
<p>Your test completes successfully, this dialog box opens.</p> 	<ol style="list-style-type: none"> Click OK. Remove Hardware Enable Input ⁽¹⁾ signal (IOD-2). Go to Tune the Axes on page 157.
<p>Your test failed, this dialog box opens.</p> 	<ol style="list-style-type: none"> Click OK. Verify the Bus status indicator turned solid green during the test. Verify that the Hardware Enable Input ⁽¹⁾ signal (IOD-2) is applied to the axis you are testing. Verify conversion constant entered in the Conversion tab. Return to main step 6 and run the test again.

(1) The hardware enable input for IDM units is on the IPIM module.

Tune the Axes

The load observer feature (available with drive firmware revision 1.124 or later) can provide good performance without having to tune your axis. Using load observer with auto-tuned gains can maximize system performance. Refer to [Appendix D](#) beginning on [page 235](#) for more load observer information.

Follow these steps to tune the axes.

1. Verify the load is still removed from the axis being tuned.



ATTENTION: To reduce the possibility of unpredictable motor response, tune your motor with the load removed first, then re-attach the load and perform the tuning procedure again to provide an accurate operational response.

2. Click the Tune tab.

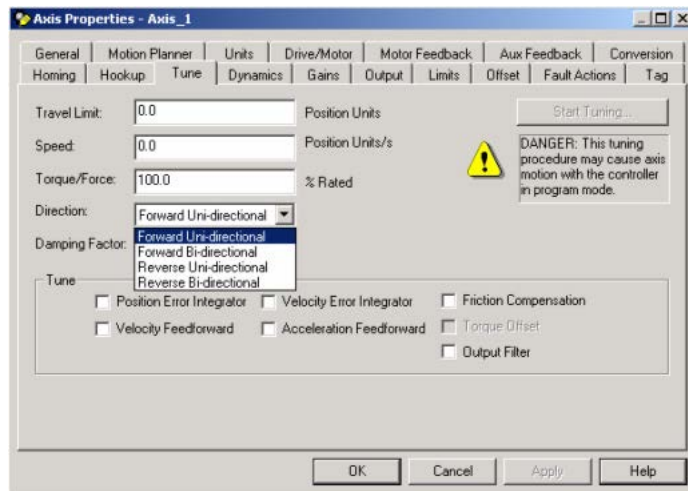

3. Type values for Travel Limit and Speed.

In this example, Travel Limit = 5 and Speed = 10. The actual value of programmed units depend on your application.

4. From the Direction pull-down menu, choose a setting.
Forward Uni-directional is default.
5. Check Tune boxes as appropriate for your application.
6. Apply Hardware Enable Input signal (IOD-2) for the axis you are tuning.



ATTENTION: To avoid personal injury or damage to equipment, apply 24V ENABLE signal (IOD-2) only to the axis you are tuning.

IMPORTANT Hardware Enable input for IDM units is on the IPIM module.

7. Click Start Tuning to auto-tune your axis.

The Online Command - Tune Servo dialog box opens. When the test completes, the Command Status changes from Executing to Command Complete.

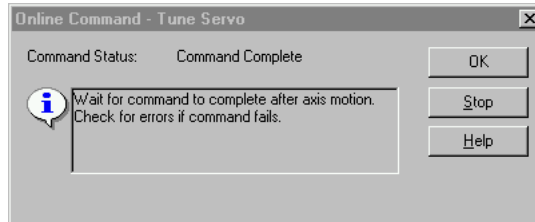

8. Click OK.

The Tune Bandwidth dialog box opens.

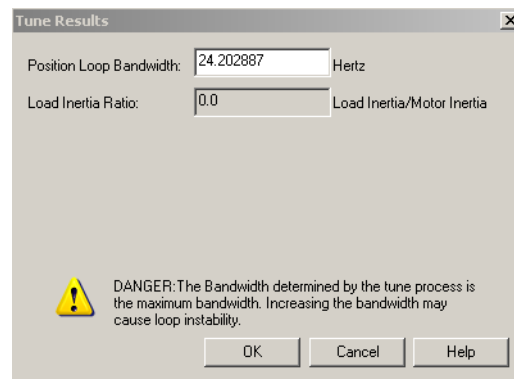

Actual bandwidth values (Hz) depend on your application and can require adjustment once motor and load are connected.

9. Record your bandwidth data for future reference.
10. Click OK.

The Online Command - Apply Tune dialog box opens. When the test completes, the Command Status changes from Executing to Command Complete.

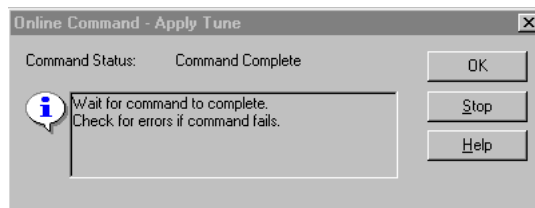

11. Click OK.

12. Determine if your test completed successfully.

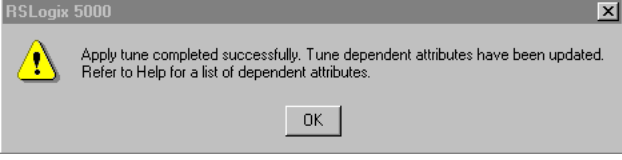
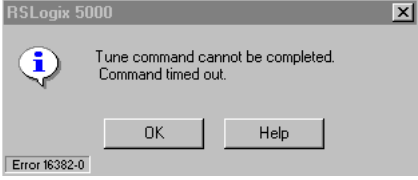
If	Then
<p>Your test completes successfully, this dialog box opens.</p> 	<ol style="list-style-type: none"> 1. Click OK. 2. Remove the Hardware Enable Input ⁽¹⁾ signal (IOD-2) applied earlier. 3. Go to step 13.
<p>Your test failed, this dialog box opens.</p> 	<ol style="list-style-type: none"> 1. Click OK. 2. Make an adjustment to motor velocity. 3. Refer to the appropriate Logix5000 motion module user manual for more information. 4. Return to step 7 and run the test again.

(1) The hardware enable input for IDM units is on the IPIM module.

13. Repeat [Test and Tune the Axes](#) for each axis.

Configure Drive Parameters and System Variables

This section provides information for accessing and changing parameters not accessible through the Logix Designer application.

IMPORTANT Drive parameters for the Kinetix 6000M IDM system are not accessible through the HIM module or DriveExplorer software.

Tools for Changing Parameters

Most parameters are accessible through the Logix Designer application. Alternatives include the DPI compatible Human Interface Module (HIM) and DriveExplorer software.

Table 95 - Software For Changing Parameters

Method	Description	Cat. No.	Firmware Revision
Software ⁽¹⁾	DriveExplorer software ⁽²⁾	9306-4EXP02ENE	2.01 or later
	Serial to SCANport adapter	1203-SSS (Series B)	3.004 or later
HIM module ⁽³⁾	Full numeric LCD HIM	20-HIM-A3	N/A

- (1) Refer to Set the Additional Bus Capacitance Parameter on [page 229](#), for more information on changing parameter values by using DriveExplorer software and 1203-SSS adapter.
- (2) Refer to DriveExplorer Getting Results Manual, publication [9306-GR001](#), for instructions.
- (3) Compatible catalog numbers include all 20-HIM-Ax.

Change Parameters with DriveExplorer Software

To navigate with DriveExplorer software, refer to the example dialog box below. In this example, the IAM I/O group folder is open, the Analog Outputs parameter group is selected, and the parameter elements are displayed in the box to the right.

IMPORTANT Parameters are read-only when the sercos ring is active. You must break the sercos ring to change parameters.
To save changes, perform a nonvolatile save (NVS) prior to cycling power.

Figure 84 - DriveExplorer Software Example

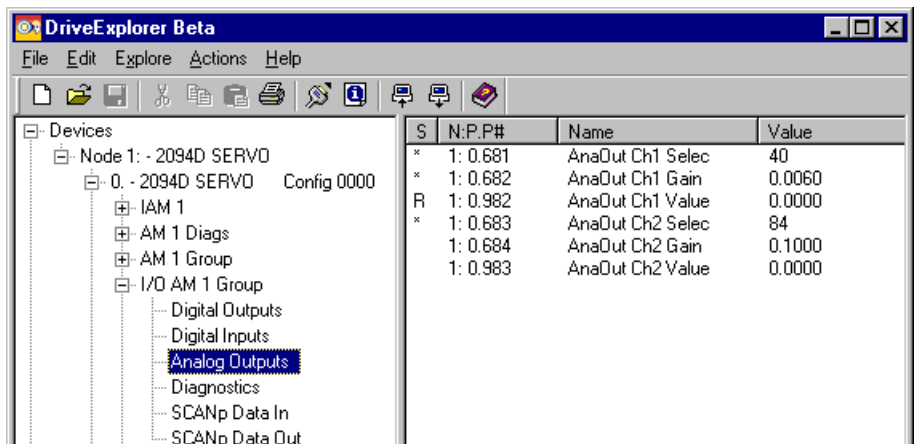

Change Parameters with the HIM Module

When using the HIM module to monitor or change parameters, use the up and down arrows (∧ and ∨) to arrive at selections. Refer to the instructions that came with your HIM module for more information.

Follow these steps to monitor or change parameters with the HIM module.

1. Select parameter, and press ↵.
2. Select I/O AM1 Group (for IAM module), and press ↵.
3. Select Analog Outputs, and press ↵.
 - a. Analog Output 1 is displayed, and press ↵.
 - b. For Analog Output 2 use arrows to select, and press ↵.
4. Press Sel.
5. Enter parameter number, and press ↵.

Monitor System Variables with Analog Test Points

There are two analog output test points accessible from the IOD 26-pin connector on the IAM and AM module.

Table 96 - IAM/AM I/O 26-pin (IOD) Connector

IOD Pin	Description	Signal
23	Analog output 0	DAC0
24	Analog output common	DAC_COM
25	Analog output 1	DAC1
26	Analog output common	DAC_COM

Figure 85 - Pin Orientation for 26-pin I/O (IOD) Connector

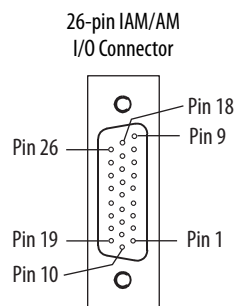

Refer to Analog Outputs on [page 69](#) for signal specifications.

Parameters begin with a variable to identify a specific axis by slot number, as follows:

- IAM module = 0 for parameters 0...999
- 1st AM module = 1 for parameters 1000...1999
- 2nd AM module = 2 for parameters 2000...2999 and so on
- 7th AM module = 7 for parameter 7000...7999

Table 97 - Monitor System Variables

Analog Output	Controlling Parameter		Scale Parameter	
	Parameter Number ⁽¹⁾	Default Value ⁽¹⁾	Parameter Number ⁽¹⁾	Default Value
1	x681	xx40	x682	0.0060
2	x683	xx84	x684	0.1000

(1) x = slot number

The value entered in Scale Parameter scales the analog output so that you can get a full scale reading of the specific parameter for the dynamic range or values you are testing.

For linear scaling specifications, refer to the table on [page 69](#).

Table 98 - Monitor Dynamic System Variables

Attribute	Parameter Number ⁽¹⁾
Velocity feedback	xx40
Velocity commanded	xx36
Torque feedback	xx84
Torque commanded	xx80

(1) x = slot number.

Troubleshooting the Kinetix 6000 Drive System

This chapter provides troubleshooting tables for your Kinetix 6000 system components.

Topic	Page
Safety Precautions	163
Interpret Status Indicators	164
General System Anomalies	173
Logix5000/Drive Fault Behavior	175

Safety Precautions

Observe these safety precautions when troubleshooting your Kinetix 6000 drive.



ATTENTION: Capacitors on the DC bus can retain hazardous voltages after input power has been removed. Before working on the drive, measure the DC bus voltage to verify it has reached a safe level or wait the full time interval as indicated in the warning on the front of the drive. Failure to observe this precaution could result in severe bodily injury or loss of life.



ATTENTION: Do not attempt to defeat or override the drive fault circuits. You must determine the cause of a fault and correct it before you attempt to operate the system. Failure to correct the fault could result in personal injury and/or damage to equipment as a result of uncontrolled machine operation.



ATTENTION: Provide an earth ground for test equipment (oscilloscope) used in troubleshooting. Failure to ground the test equipment could result in personal injury.

Interpret Status Indicators

Refer to these troubleshooting tables to identify faults, potential causes, and the appropriate actions to resolve the fault. If the fault persists after attempting to troubleshoot the system, please contact your Rockwell Automation sales representative for further assistance.

Kinetix 6000M IDM System Error Codes

The IAM module reports a single, generic IPIM Fault whenever a fault occurs on any IPIM in the same backplane as the IAM module. All IPIM faults result in an open contactor. The Logix5000 Axis Tag for this fault is IPIMFault.

The IPIM module is not a sercos device, so the IAM module reports any IPIM faults to the Logix5000 motion subsystem. IPIM faults are reset by performing a fault reset on the IAM module. Issuing a fault reset command to the IAM module also generates a fault reset to all the IPIM modules in the same backplane as the IAM. Detailed information about the IPIM fault status can be obtained by messaging to the IAM module.

Connecting the IPIM module into the Logix5000 environment as an EtherNet/IP device does not disable fault reporting through the IAM module. Only the IAM fault reporting lets the Logix5000 motion sub-system take action based on the IPIM module fault status. IPIM faults are also reported over the Ethernet connection. However, IPIM faults must be reset by applying a fault reset instruction to the IAM module. The integration of the IPIM module into the Logix5000 environment through the EtherNet/IP network provides additional capabilities you can choose to take advantage of in your program.

Refer to the Kinetix 6000M Integrated Drive-Motor System User Manual, publication [2094-UM003](#), for more information on troubleshooting the IDM drive-motor system.

Kinetix 6000 Drive System Error Codes

The following list of problematic symptoms (no error code shown) and faults with assigned error codes is designed to help you resolve anomalies.

When a fault is detected, the seven-segment status indicator displays an E followed by the flashing of the two-digit error code, one digit at a time. This is repeated until the error code is cleared.

Table 99 - Seven-segment Status Indicator Error Codes

Error Code	Fault Message - Logix Designer (HIM)	Anomaly or Symptom	Potential Cause	Possible Resolution
No Error Code Displayed		Power (PWR) indicator not ON	No AC power or auxiliary logic power.	Verify AC control power is applied to the Kinetix 6000 system.
			Internal power supply malfunction.	Call your Rockwell Automation sales representative to return module for repair.
		Motor jumps when first enabled	Motor wiring error.	<ul style="list-style-type: none"> Check motor wiring. Run Hookup test in the Logix Designer application.
			Incorrect motor chosen.	Verify the proper motor is selected.
		Digital I/O not working correctly	I/O power supply disconnected.	Verify connections and I/O power source.
E00	BusUndervoltage Fault (Blown fuse)	A blown fuse was detected on the inverter PCB	Blown fuse.	Call your Rockwell Automation sales representative to return module for repair.
E04	MotorOvertemp Fault (Motor Overtemp)	Motor thermal switch tripped	<ul style="list-style-type: none"> High motor ambient temperature and/or Excessive current 	<ul style="list-style-type: none"> Operate within (not above) the continuous torque rating for the ambient temperature 40 °C (104 °F) maximum. Lower ambient temperature, increase motor cooling.
			Motor wiring error.	Check motor wiring at MF connector on the IAM/AM module.
			Incorrect motor selection.	Verify the proper motor has been selected.
E05	DriveOvercurrent Fault (Power Fault)	Self-protection of the Intelligent Power Module (IPM) is indicating a major power related fault condition.	Motor cables shorted.	Verify continuity of motor power cable and connector.
			Motor winding shorted internally.	Disconnect motor power cables from the motor. If the motor is difficult to turn by hand, consider replacing the motor.
			Kinetix 6000 drive temperature too high.	<ul style="list-style-type: none"> Check for clogged vents or defective fan. Make sure cooling is not restricted by insufficient space around the unit.
			Operation above continuous power rating and/or product environmental ratings.	<ul style="list-style-type: none"> Verify ambient temperature is not too high. Operate within the continuous power rating. Reduce acceleration rates.
			Kinetix 6000 drive has a short circuit, overcurrent, or failed component.	Remove all power and motor connections, and perform a continuity check from the DC bus to the U, V, and W motor outputs. If a continuity exists, check for wire fibers between terminals, or send drive in for repair.
E06	HardOvertravel Fault (+/- Hard Overtravel)	Axis moved beyond the physical travel limits in the positive/negative direction.	Dedicated overtravel input is inactive.	<ul style="list-style-type: none"> Check wiring. Verify motion profile. Verify axis configuration in software.
E07	MotFeedbackFault (Motor Feedback Loss)	The feedback wiring is open, shorted, or missing.		<ul style="list-style-type: none"> Check motor encoder wiring. Run Hookup test in the Logix Designer application.

Table 99 - Seven-segment Status Indicator Error Codes (continued)

Error Code	Fault Message - Logix Designer (HIM)	Anomaly or Symptom	Potential Cause	Possible Resolution
E09	BusUndervoltage Fault (Bus Undervoltage)	With three-phase power present, the DC bus voltage is below limits.	<ul style="list-style-type: none"> DC bus voltage for 460V system is below 275V DC bus voltage for 230V system is below 137V 	<ul style="list-style-type: none"> Verify voltage level of the incoming AC power. Check AC power source for glitches or line drop. Install an uninterruptible power supply (UPS) on your AC input.
		DC bus voltage fell below the undervoltage limit while an axis on the follower power rail was enabled.		
E10	DriveOvervoltage Fault (Bus Overvoltage)	The DC bus voltage is above limits.	Excessive regeneration of power. When the motor is driven by an external mechanical power source, it can regenerate too much peak energy through the drive power supply. The system faults to save itself from an overload.	<ul style="list-style-type: none"> Change the deceleration or motion profile. Use a larger system (motor and Kinetix 6000 drive). Install shunt module.
			<ul style="list-style-type: none"> DC bus voltage for 460V system is over 820V DC bus voltage for 230V system is over 410V 	
E11	MotFeedbackFault (Illegal Hall State)	State of Hall feedback inputs is incorrect.	Improper connections.	<ul style="list-style-type: none"> Verify the Hall wiring at the MF connector on the IAM/AM module. Verify 5V power supply to the encoder.
E16	Softovertravel Fault (+/- Software Overtravel)	Axis position exceeded maximum software setting.		<ul style="list-style-type: none"> Verify motion profile. Verify overtravel settings are appropriate.
E18	OverSpeedFault (Overspeed Fault)	Motor speed has exceeded 150% of maximum rated speed. The 100% trip point is dictated by the lesser of the user velocity limits or the motor rated base speed.		<ul style="list-style-type: none"> Check cables for noise. Check tuning.
E19	PositionErrorFault (Follow Error)	Position error limit was exceeded.		<ul style="list-style-type: none"> Increase the feed forward gain. Increase following error limit or time. Check position loop tuning. Verify sizing of system. Verify mechanical integrity of system within specification limits.
E20	MotFeedbackFault (Mtr Fdbk AQB)	Motor Encoder State Error	The motor encoder encountered an illegal transition.	<ul style="list-style-type: none"> Use shielded cables with twisted pair wires. Route the feedback away from potential noise sources. Check the system grounds. Replace the motor/encoder.
E21	AuxFeedbackFault (Aux Feedback Comm)	Communication was not established with an intelligent encoder.		Verify auxiliary encoder wiring.
E30	MotFeedbackFault (Motor Feedback Comm)	Communication was not established with an intelligent encoder.		<ul style="list-style-type: none"> Verify motor selection. Verify the motor supports automatic identification. Verify motor encoder wiring.

Table 99 - Seven-segment Status Indicator Error Codes (continued)

Error Code	Fault Message - Logix Designer (HIM)	Anomaly or Symptom	Potential Cause	Possible Resolution
E34	GroundShortFault (Ground Fault)	Excessive ground current in the converter was detected.	Wiring error.	<ul style="list-style-type: none"> Check motor power wiring. Check input power wiring.
			Motor internal ground short.	Replace motor.
			Internal malfunction.	Disconnect motor power cable from drive and enable drive with current limit set to 0. If fault clears, then a wiring error or motor internal anomaly exists. If fault remains, call your sales representative.
			Grounded control power terminal (applies to 230V systems only)	<ul style="list-style-type: none"> Remove ground from control power input. Source control power from three-phase input power (refer to page 190). Add isolation transformer for control power.
E35	DriveUndervoltage Fault (Pre-charge Fault)	Converter pre-charge cycle failed.	Low AC input voltage.	Check input AC voltage on all phases.
			Internal malfunction.	Call your sales representative.
E36	DriveOvertemp Fault (System Overtemperature)	Converter thermal switch tripped.	Excessive heat exists in the power circuitry.	<ul style="list-style-type: none"> Reduce acceleration rates. Reduce duty cycle (ON/OFF) of commanded motion. Increase time permitted for motion. Use larger IAM converter module. Check for clogged vents or defective fan. Make sure cooling is not restricted by insufficient space around the unit.
E37	PowerPhaseLoss Fault (Phase Loss Flt)	<ul style="list-style-type: none"> One or more phases of the input AC power is missing. Axis was enabled when main (three-phase) power was removed. common-bus follower axis was enabled when DC bus power was removed. 		<ul style="list-style-type: none"> Check input AC voltage on all phases. Disable axis before removing power.
E38	SercosFault (Sercos Ring Flt)	The sercos ring is not active after being active and operational.	Cable disconnected.	Check that fiber-optic cable is present and connected properly.
E39	DriveHardFault (Self Sense Flt)	Self-sensing Commutation Start-up Error	Motion required for self-sensing start-up commutation was obstructed.	<ul style="list-style-type: none"> Verify that there are no impediments to motion at startup, such as hard limits. Increase self-sensing current if high friction or load conditions exist. Check motor or encoder wiring by using wiring diagnostics.
E43	DriveEnableInput Fault (Drive Enable Flt)	Missing Drive Enable Input Signal	<ul style="list-style-type: none"> An attempt was made to enable the axis through software while the Drive Enable hardware input was inactive. The Drive Enable input transitioned from active to inactive while the axis was enabled. 	<ul style="list-style-type: none"> Disable the Drive Enable Input fault. Verify that Drive Enable hardware input is active whenever the drive is enabled through software.
E49	DriveHardFault (Safe-off HW Flt)	Safe torque-off function mismatch. Drive does not allow motion.	<ul style="list-style-type: none"> Loose wiring at STO connector. Cable/header not seated properly in STO connector. Safe torque-off circuit missing +24V DC. 	<ul style="list-style-type: none"> Verify wire terminations, cable/header connections, and +24V. Reset error and run proof test. If error persists, return the drive to Rockwell Automation.
E50	SercosFault (Sercos Same ADDR)	Duplicate node address detected on sercos ring.		Verify that each sercos drive is assigned a unique node address.
E54	DriveHardFault (Ifbk HW Fault)	Current feedback hardware fault detected.		Replace the module
E60	DriveHardFault (Unknown Axis)	Illegal ID bits detected		Replace the module

Table 99 - Seven-segment Status Indicator Error Codes (continued)

Error Code	Fault Message - Logix Designer (HIM)	Anomaly or Symptom	Potential Cause	Possible Resolution
E61	AuxFeedbackFault (Aux Fdbk AQB)	Auxiliary Encoder State Error	The auxiliary encoder encountered an illegal transition.	<ul style="list-style-type: none"> Use shielded cables with twisted pair wires. Route the feedback away from potential noise sources. Check the system grounds. Replace the motor/encoder.
E62	AuxFeedbackFault (Aux Fdbk Loss)	The feedback wiring is open, shorted, or missing.		Check the motor feedback cable connectors/wiring to the IAM/AM module and servo motor.
E63	AuxFeedbackNoise (Aux Fdbk Noise)	Noise on auxiliary feedback cable.	Recommended grounding, per installation instructions, has not been followed.	<ul style="list-style-type: none"> Verify grounding. Route feedback cable away from noise sources. Refer to System Design for Control of Electrical Noise Reference Manual, publication GMC-RM001.
E64	MotorFeedbackNoise (Mtr Fdbk Noise)	Noise on motor feedback cable.		
E65	No Fault Message (condition indicated by on-screen message) (Hookup Fault)	Hookup procedure failed	Motor or feedback device malfunction.	<ul style="list-style-type: none"> Check motor power/feedback wiring. Refer to on-screen message for resolution.
E66	No Fault Message (condition indicated by on-screen message) (Atune Flt)	Autotune procedure failed	Motor or feedback device malfunction.	<ul style="list-style-type: none"> Check motor power/feedback wiring. Refer to on-screen message for resolution. Perform Hookup in the Logix Designer application. Consult application help screen.
E67	DriveHardFault (Task init)	Operating system failed	Software initialization fault detected due to hardware failure.	<ul style="list-style-type: none"> Cycle power. If fault persists, replace module.
E68	DriveHardFault (SCANport™ Comm)	DPI communication failed	The DPI device or cable is faulty.	Check DPI connections.
E69	DriveHardFault (Objects Init)	Nonvolatile memory is corrupt due to control board hardware failure.		Load default parameters, save to nonvolatile memory, and recycle power or reset the drive.
E70	DriveHardFault (NV Mem Init)	Nonvolatile memory is corrupt due to control board software error.		Load default parameters, save to nonvolatile memory, and recycle power or reset the drive.
E71	DriveHardFault (Memory Init)	RAM or nonvolatile memory validation failure		<ul style="list-style-type: none"> Cycle power. If fault persists, replace module.
E72	DriveOvertemp Fault (Drive Overtemp)	Inverter thermal switch tripped	The IAM or an AM module fan failed.	Replace the failed module.
			The cabinet ambient temperature is above rating.	Check the cabinet temperature.
			The machine duty cycle requires an RMS current exceeding the continuous rating of the controller.	Change the command profile to reduce speed or increase time.
			The airflow access to the Kinetix 6000 system is limited or blocked.	Check airflow and re-route cables away from the Kinetix 6000 system.
E73	Communicate (Backplane Comm)	Power rail CAN communication failed.		Check module for proper mount.
		Power rail connection shorted or open.		Check power rail and module for foreign objects.
E74	DriveOvercurrent Fault (Bus OverCurrent)	DC link current exceeds rating.	Motor or transmission malfunction.	<ul style="list-style-type: none"> Check for proper motor sizing. Check/replace transmission device. Check/replace motor.
			IAM module not sized properly.	<ul style="list-style-type: none"> Check for proper IAM module sizing. Install larger kW rated IAM module.
E75	DriveOvervoltage Fault (Shunt Time Out)	The IAM/AM module, or shunt module has exceeded its shunt resistor continuous rating.		<ul style="list-style-type: none"> Use a properly sized shunt or modify duty cycle of the application. System uses internal shunt and requires external shunt for additional capacity.

Table 99 - Seven-segment Status Indicator Error Codes (continued)

Error Code	Fault Message - Logix Designer (HIM)	Anomaly or Symptom	Potential Cause	Possible Resolution
E76	DriveHardFault (CAN Init)	DPI hardware initialization fault detected.	Control board hardware failure.	<ul style="list-style-type: none"> Reset System. If fault persists, replace system module.
E77	DriveHardFault (Module Mismatch)	Either 230V AM module is installed on power rail with 460V IAM module, or 460V AM module is installed on power rail with 230V IAM module.		Replace mismatched module.
E78	DriveHardFault (Sercos Init)	Control hardware fault detected.		<ul style="list-style-type: none"> Cycle power. If fault persists, replace module.
E79	DriveOvervoltage Fault (Shunt Module Flt)	Over-temperature fault indicator on Bulletin 2094 shunt module is steady red.		Refer to Temperature Fault Status Indicator on page 172 .
		Shunt-fault indicator on Bulletin 2094 shunt module is steady red.		Refer to Shunt Fault Status Indicator on page 172 .
		Bulletin 2094 shunt module is missing from power rail.		<ul style="list-style-type: none"> Install missing module on power rail. Fill empty slot with slot-filler module.
E80	DriveHardFault (CPLD Flt)	Control hardware fault detected.		Replace module.
E81	DriveHardFault (Common Bus Flt)	Follower IAM module detected AC input power being applied.		Remove AC input power connections from follower IAM module.
E90	DriveHardFault (Pre-charge Timeout Flt)	Pre-charge resistor power exceeds the resistor rating.		Wait for resistor to cool.
E95	IPIMFault (IPIM Module Flt)	A fault has occurred in one or more IPIM modules on the power rail.		Refer to the troubleshooting chapter in the Kinetix 6000M Integrated Drive-Motor System User Manual, publication 2094-UM003 .

IAM/AM Module Status Indicators

Table 100 - Drive Status Indicator

Drive Status Indicator	Drive Status	Possible Resolution
Off	Normal, no faults	N/A
Steady red	Drive faulted	Refer to seven-segment error code and Kinetix 6000 Drive System Error Codes troubleshooting on page 165 .

Table 101 - Comm Status Indicator

Comm Status Indicator	Drive Status	Potential Cause	Possible Resolution
Off	No communication ⁽¹⁾	Loose fiber-optic connection.	Verify proper fiber-optic cable connections.
		Broken fiber-optic cable.	Replace fiber-optic cable.
		Receive fiber-optic cable connected to sercos transmit connector and vice versa.	Check proper sercos fiber-optic cable connections.
Flashing green	Establishing communication	System is still in the process of establishing sercos communication.	Wait for steady green indicator.
		Node address setting on the drive module does not match sercos controller configuration.	Verify proper node switch setting.
Steady green	Communication ready	No faults or failures.	N/A

(1) Refer to Fiber-optic Cable Installation and Handling Instructions, publication [2090-IN010](#), for more information.

Table 102 - Bus Status Indicator

Bus Status Indicator	Bus Status	Condition
Off	No power or DC bus is not present.	<ul style="list-style-type: none"> Normal when bus power is not applied. Fault exists, refer to seven-segment error code and Kinetix 6000 Drive System Error Codes troubleshooting on page 165.
	Bus power is present in follower IAM.	<ul style="list-style-type: none"> Follower IAM module is not configured as CommonBus Follow in the Logix Designer application. After DC bus voltage is applied, a 2.5 second delay before the indicator begins flashing green is normal operation to provide the common-bus leader module time to complete pre-charge.
Flashing green	Bus power is present, axis disabled. No faults.	Normal when: <ul style="list-style-type: none"> 24V is not applied to Hardware Enable Input (IOD-2). MSO instruction is not commanded in the Logix Designer application.
Steady green	Bus power is present, axis enabled. No faults.	Normal when: <ul style="list-style-type: none"> 24V is applied to Hardware Enable Input (IOD-2). MSO instruction is commanded in the Logix Designer application.

Shunt Module Status Indicators

Each of the shunt module status indicators provide specific troubleshooting information.

Table 103 - General Shunt Module Troubleshooting

Module	Status	Under These Conditions
Shunt	Fault is latched.	Until fault condition is corrected and cleared.
	Fault is cleared.	<ul style="list-style-type: none"> Using MASR, MAFR, MGSR instructions or the HIM (red stop button). Only after the DC bus is discharged (bus status indicator is flashing). Drive must be configured with 2094-BSP2 shunt module or Bulletin 1394 external shunt module.
IAM/AM	Disabled (for DC bus regulation).	<ul style="list-style-type: none"> When the 2094-BSP2 shunt module is used on a 230V system. When either 230V or 460V system is configured with a Bulletin 1394 external shunt module. When configured in Common-bus Follower mode.
	Enabled to discharge the DC bus.	Drive (IAM or leader IAM module) three-phase power is removed.
	Disabled from discharging the DC bus.	When configured in Common-bus Follower mode.

IMPORTANT Under some fault conditions, two reset commands can be required to clear drive and shunt module faults.

Table 104 - Bus Status Indicator

Bus Status Indicator	Status	Potential Cause	Possible Resolution
Flashing	Normal condition when control power is applied and bus voltage is less than 60V DC.		N/A
Steady Green	Normal condition when control power is applied and bus voltage is greater than 60V DC.		N/A
Off	Control power is not present.	Internal power supply failure.	Replace shunt module.

Table 105 - Temperature Fault Status Indicator

Over-Temp Fault Indicator	Status	Potential Cause	Possible Resolution
Off	Normal condition.		N/A
Steady Red	Shunt module internal temperature exceeds operating temperature specification.	Shunt module fan failed.	Replace shunt module.
		Shunt module temperature exceeds rating.	<ul style="list-style-type: none"> Wait for shunt module to cool. Reset faults. Verify IAM module bus regulator configuration.
	External over temperature condition.	External temperature switch is open.	<ul style="list-style-type: none"> Wait for shunt module to cool. Reset faults. Verify IAM module bus regulator configuration.
		TS jumper is not present.	Install jumper.

Table 106 - Shunt Fault Status Indicator

Shunt Fault Indicator	Status	Potential Cause	Possible Resolution
Off	Normal condition		N/A
Steady Red	Shorted internal or external shunt resistor.	Mis-wired shunt jumper or other short on RC connector.	<ul style="list-style-type: none"> Correct mis-wire (shorted) condition. If anomaly persists, replace shunt module.
		Mis-wired (shorted) external shunt wiring.	

Table 107 - All Shunt Module Status Indicators

Shunt Module Status Indicator	Status	Potential Cause	Possible Resolution
<ul style="list-style-type: none"> Bus Status Over-Temp Fault Shunt Fault 	All three status indicators flash simultaneously.	Shunt module hardware failure.	<ul style="list-style-type: none"> Cycle power. If anomaly persists, replace shunt module.

General System Anomalies

These anomalies do not always result in a fault code, but can require troubleshooting to improve performance.

Table 108 - General System Anomalies

Condition	Potential Cause	Possible Resolution
Axis or system is unstable.	The position feedback device is incorrect or open.	Check wiring.
	Unintentionally in Torque mode.	Check to see what primary operation mode was programmed.
	Motor tuning limits are set too high.	Run Tune in the Logix Designer application.
	Position loop gain or position controller acceleration or deceleration rate is improperly set.	Run Tune in the Logix Designer application.
	Improper grounding or shielding techniques are causing noise to be transmitted into the position feedback or velocity command lines, causing erratic axis movement.	Check wiring and ground.
	Motor Select limit is incorrectly set (servo motor is not matched to axis module).	<ul style="list-style-type: none"> • Check setups. • Run Tune in the Logix Designer application.
	Mechanical resonance.	Notch filter or output filter can be required (refer to Axis Properties dialog box, Output tab in the Logix Designer application).
You cannot obtain the motor acceleration/deceleration that you want.	Torque Limit limits are set too low.	Verify that current limits are set properly.
	Incorrect motor selected in configuration.	Select the correct motor and run Tune in the Logix Designer application again.
	The system inertia is excessive.	<ul style="list-style-type: none"> • Check motor size versus application need. • Review servo system sizing.
	The system friction torque is excessive.	Check motor size versus application need.
	Available current is insufficient to supply the correct acceleration or deceleration rate.	<ul style="list-style-type: none"> • Check motor size versus application need. • Review servo system sizing.
	Acceleration limit is incorrect.	Verify limit settings and correct them, as necessary.
	Velocity Limit limits are incorrect.	Verify limit settings and correct them, as necessary.
Motor does not respond to a velocity command.	The axis cannot be enabled for 1.5 seconds after disabling.	Disable the axis, wait for 1.5 seconds, and enable the axis.
	Enable signal has not been applied or the enable wiring is incorrect.	<ul style="list-style-type: none"> • Check the controller. • Check the wiring.
	The motor wiring is open.	Check the wiring.
	The motor thermal switch has tripped.	<ul style="list-style-type: none"> • Check for a fault. • Check the wiring.
	The motor has malfunctioned.	Repair or replace the motor.
	The coupling between motor and machine has broken (for example, the motor moves, but the load/machine does not).	Check and correct the mechanics.
	Primary operation mode is set incorrectly.	Check and properly set the limit.
	Velocity or current limits are set incorrectly.	Check and properly set the limits.

Table 108 - General System Anomalies (continued)

Condition	Potential Cause	Possible Resolution
Presence of noise on command or motor feedback signal wires.	Recommended grounding per installation instructions have not been followed.	<ul style="list-style-type: none"> Verify grounding. Route wire away from noise sources. Refer to System Design for Control of Electrical Noise, publication GMC-RM001.
	Line frequency present.	<ul style="list-style-type: none"> Verify grounding. Route wire away from noise sources.
	Variable frequency can be velocity feedback ripple or a disturbance caused by gear teeth or ballscrew balls, for example. The frequency can be a multiple of the motor power transmission components or ballscrew speeds resulting in velocity disturbance.	<ul style="list-style-type: none"> Decouple the motor for verification. Check and improve mechanical performance, for example, the gearbox or ballscrew mechanism.
No rotation	The motor connections are loose or open.	Check motor wiring and connections.
	Foreign matter is lodged in the motor.	Remove foreign matter.
	The motor load is excessive.	Verify the servo system sizing.
	The bearings are worn.	Return the motor for repair.
	The motor brake is engaged (if supplied).	<ul style="list-style-type: none"> Check brake wiring and function. Return the motor for repair.
	The motor is not connect to the load.	Check coupling.
Motor overheating	The duty cycle is excessive.	Change the command profile to reduce acceleration or deceleration or increase time.
	The rotor is partially demagnetized causing excessive motor current.	Return the motor for repair.
Abnormal noise	Motor tuning limits are set too high.	Run Tune in the Logix Designer application.
	Loose parts are present in the motor.	<ul style="list-style-type: none"> Remove the loose parts. Return motor for repair. Replace motor.
	Through bolts or coupling is loose.	Tighten bolts.
	The bearings are worn.	Return motor for repair.
	Mechanical resonance.	Notch filter can be required (refer to Axis Properties dialog box, Output tab in the Logix Designer application).
Erratic operation - Motor locks into position, runs without control or with reduced torque.	Motor power phases U and V, U and W, or V and W reversed.	Check and correct motor power wiring.
	Sine, Cosine or Rotor leads are reversed in the feedback cable connector.	Check and correct motor feedback wiring.
	Sine, Cosine, Rotor lead sets of resolver feedback are reversed.	Check and correct motor feedback wiring.

Logix5000/Drive Fault Behavior

These fault actions are configurable from the Axis Properties dialog box, Fault Actions tab in the Logix Designer application.

Table 109 - Drive Fault Action Definitions

Drive Fault Action	Definition
Shutdown	The drive disables the axis as defined in Logix5000/Drive Fault Behavior, Table 110 . In addition, the axis in Logix enters the Shutdown state, which disables any axes that are using this axis as a camming or gearing master. In addition, the AxisHomedStatus tag for the faulted axis is cleared. Shutdown is the most severe action to a fault and it is usually reserved for faults that could endanger the machine or operator if power is not removed as quickly as possible.
Disable Drive	The drive disables the axis as defined in Logix5000/Drive Fault Behavior, Table 110 .
Stop Motion	The axis decelerates at the maximum deceleration rate (set in the Logix Designer application>Axis Properties>Dynamics tab). Once the axis has come to a stop, the servo loops remain enabled but no further motion can be generated until the fault is reset. This is the gentlest stopping mechanism in response to a fault. It is usually used for less severe faults.
Status Only	The drive continues to operate. Status is provided by the seven-segment fault status indicator, drive status indicator, and DPI (if used). The application program must handle any motion faults. In general, use this setting in applications where the standard fault actions are not appropriate.

Only selected faults are programmable. In the Logix5000/Drive Fault Behavior table on [page 176](#), the controlling attribute is given for programmable fault actions. All faults that are not configurable have a fault action of Shutdown.

Figure 86 - Axis Properties - Fault Actions Tab

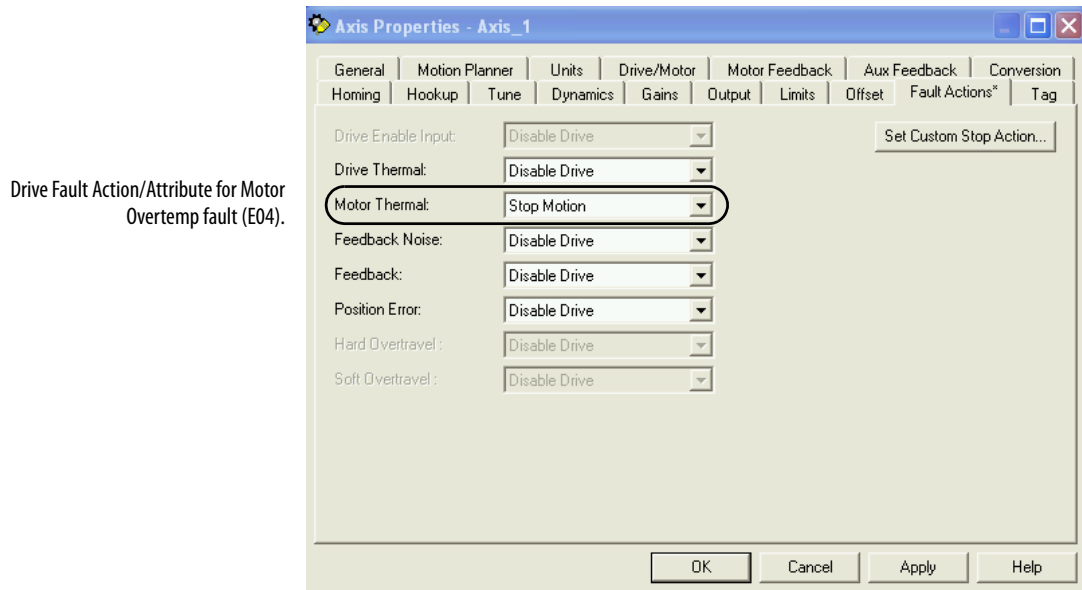

Table 110 - Logix5000/Drive Fault Behavior

Logix5000 Fault Message (HIM Message)	Error Code	Description	Drive Fault Action/ Attribute	Logix Designer Programmable Fault Action?
BusUndervoltageFault (Blown fuse)	E00	A blown fuse was detected in the inverter pcb.	Coast/Disable (open contactor enable relay)	No
MotorOvertempFault (Motor Overtemp)	E04 ⁽¹⁾	The motor thermal switch was tripped. Firmware I ² t protection does not generate a fault, rather it dynamically folds back current when 110% of motor rating is reached. Setting the Motor Thermal fault action to Status Only or Stop Motion bypasses the foldback behavior and allows the fault to occur.	N/A	Yes Motor Thermal
DriveOvercurrentFault (Power Fault)	E05	An instantaneous over-current was detected in the inverter power section.	Coast/Disable (open contactor enable relay)	No
HardOvertravelFault (+/- Hard Overtravel)	E06	Axis moved beyond the physical travel limits in the positive/negative direction. This fault can be configured for status only.	Decel/Disable	Yes Hard Overtravel
MotFeedbackFault (Motor Feedback Loss)	E07	The feedback wiring is open, shorted or missing.	Coast/Disable	No
BusUndervoltageFault (Bus Under Voltage)	E09	With 3-phase present, the DC bus voltage is below limits. The trip point is 275V and 137V DC for 460V/230V drives respectively. DC bus voltage is below limits when any axis on common-bus follower power rail was enabled.	Coast/Disable (open contactor enable relay)	No
DriveOvervoltageFault (Bus Overvoltage)	E10	The DC bus voltage is above limits. The trip point is 820V and 410V DC for 460V/230V drives respectively.	Coast/Disable (open contactor enable relay)	No
MotFeedbackFault (Illegal Hall State)	E11	State of Hall feedback inputs is incorrect.	Coast/Disable	No
SoftovertravelFault (+/- Software Overtravel)	E16	Axis position exceeded maximum software setting in the positive/negative direction. This fault can be configured for status only.	Decel/Disable	Yes Soft Overtravel
OverSpeedFault (Overspeed Fault)	E18	Axis speed has reached 150% of the maximum rated setting. The 100% trip point is dictated by the lesser of the user velocity limits or the motor rated base speed.	Coast/Disable	No
PositionErrorFault (Follow Error)	E19	Axis position error limit has been exceeded. This fault can be configured for status only.	Decel/Disable	Yes Position Error
MotFeedbackFault (Mtr Fdbk AQB)	E20	Motor encoder has encountered an illegal state transition.	Coast/Disable	No
AuxFeedbackFault (Aux Feedback Comm)	E21	Communication was not established with an intelligent (Stegmann) encoder on the Auxiliary feedback port.	Decel/Disable	No
MotFeedbackFault (Motor Feedback Comm)	E30	Communication was not established with an intelligent (Stegmann) encoder on the Motor feedback port.	Decel/Disable	No
GroundShortFault (Ground Fault)	E34	Excessive ground current in the converter was detected.	Coast/Disable (open contactor enable relay)	No
DriveUndervoltageFault (Precharge Fault)	E35	The converter pre-charge cycle has failed.	Coast/Disable (open contactor enable relay)	No
DriveOvertempFault (System Overtemperature)	E36 ⁽²⁾	Converter internal temperature limit exceeded.	Coast/Disable (open contactor enable relay)	No
PowerPhaseLossFault (Phase Loss Flt)	E37	One or two phases of the input AC power are missing. <ul style="list-style-type: none"> • All phases of the input AC power are missing. • Axis was enabled when main (three-phase) power was removed. • Common-bus follower axis was enabled when DC bus power was removed. 	Coast/Disable (open contactor enable relay) Decel/Disable	No

Table 110 - Logix5000/Drive Fault Behavior (continued)

Logix5000 Fault Message (HIM Message)	Error Code	Description	Drive Fault Action/ Attribute	Logix Designer Programmable Fault Action?
SercosFault (Sercos Ring Flt)	E38	The sercos ring is not active after being active and operational.	Decel/Disable	No
DriveHardFault (Self Sense Flt)	E39	Self-sensing commutation fault detected.	Coast/Disable	No
DriveEnableInputFault (Drive Enable Flt)	E43	Generated when Enable input switches off when drive is enabled.	Decel/Disable	Yes Drive Enable Input
DriveHardFault (Safe-Off HW Flt)	E49	Safe torque-off function mismatch. Drive does not allow motion. Refer to the Kinetix Safe Torque-off Feature Safety Reference Manual, publication GMC-RM002 , for more information. Applies to 2094-xCxx-Mxx-S IAM and 2094-xMxx-S AM modules with safe torque-off feature.	Coast/Disable (open contactor enable relay)	No
SercosFault (Sercos Same ADDR)	E50	Duplicate node address detected on sercos ring.	Decel/Disable	No
DriveHardFault (Ifbk HW Fault)	E54	Current feedback hardware fault detected.	Coast/Disable (open contactor enable relay)	No
DriveHardFault (Unknown Axis)	E60	Invalid module type identified by firmware when applying power.	Coast/Disable (open contactor enable relay)	No
AuxFeedbackFault (Aux Fdbk AQB)	E61	Auxiliary encoder has encountered an illegal state transition.	Coast/Disable	No
AuxFeedbackFault (Aux Fdbk Loss)	E62	The feedback wiring is open, shorted or missing.	Coast/Disable	No
AuxFeedbackNoise (Aux Fdbk Noise)	E63	Presence of noise on auxiliary feedback cable.	Coast/Disable	Yes Feedback Noise
MotorFeedbackNoise (Mtr Fdbk Noise)	E64	Presence of noise on motor feedback cable.		
No Fault Message (condition indicated by on-screen message) (Hookup Fault)	E65	Hookup procedure failed.	Coast/Disable	No
No Fault Message (condition indicated by on-screen message) (Atune Flt)	E66	Autotune procedure failed.	Coast/Disable	No
DriveHardFault (Task init)	E67	Operating system failed.	Coast/Disable (open contactor enable relay)	No
DriveHardFault (SCANport Comm)	E68	DPI communication failed.	Decel/Disable	No
DriveHardFault (Objects Init)	E69	Nonvolatile memory attribute out of range.	Coast/Disable (open contactor enable relay)	No
DriveHardFault (NV Mem Init)	E70	Nonvolatile memory corrupted.	Coast/Disable (open contactor enable relay)	No
DriveHardFault (Memory Init)	E71	RAM or nonvolatile memory validation failure.	Coast/Disable (open contactor enable relay)	No

Table 110 - Logix5000/Drive Fault Behavior (continued)

Logix5000 Fault Message (HIM Message)	Error Code	Description	Drive Fault Action/ Attribute	Logix Designer Programmable Fault Action?
DriveOvertempFault (Drive Overtemp)	E72	Inverter temperature limit exceeded. Firmware I ² t protection does not generate a fault, rather it dynamically folds back current when 110% of drive rating is reached. Setting the Drive Thermal fault action to Status Only or Stop Motion bypasses the foldback behavior and allows the fault to occur.	N/A	Yes Drive Thermal
Communicate (Backplane Comm)	E73	Power rail backplane CAN communication failed.	Decel/Disable	No
DriveOvercurrentFault (Bus OverCurrent)	E74	The converter has exceeded its converter rating.	Coast/Disable (open contactor enable relay)	No
DriveOvervoltageFault (Shunt Time Out)	E75	The IAM/AM module or shunt module has exceeded its shunt resistor continuous rating. SHUTDOWN for IAM module, DISABLE for AM module. IAM module provides fault handling for shunt module.	Coast/Disable (open contactor enable relay)	No
DriveHardFault (Can Init)	E76	Either DPI or backplane CAN initialization failure.	Coast/Disable (open contactor enable relay)	No
DriveHardFault (Module Mismatch)	E77	Generated by IAM module if the power rating of an AM module on the same power rail does not match with IAM module input power rating.	Coast/Disable (open contactor enable relay)	No
DriveHardFault Sercos Init	E78	Control hardware fault detected.	Coast/Disable (open contactor enable relay)	No
DriveOvervoltageFault (Shunt Module Flt)	E79	Power rail mounted shunt module fault. Displayed on IAM module seven-segment fault status indicator.	Coast/Disable (open contactor enable relay)	No
HardwareFault (CPLD Flt)	E80	Control hardware fault detected.	Coast/Disable (open contactor enable relay)	No
HardwareFault (Common Bus Flt)	E81	Common-bus follower IAM module detected AC input power being applied.	Coast/Disable (open contactor enable relay)	No
HardwareFault (Pre-charge Timeout Flt)	E90	Pre-charge resistor power exceeds the resistor rating.	Coast/Disable (open contactor enable relay)	No
IPIMFault (IPIM Module Flt)	E95	A fault has occurred in one or more IPIM modules on the power rail.	Coast/Disable (open contactor enable relay)	No

- (1) The Logix5000 Motor Thermal Fault Action is tied to the motor thermostat fault. If this is set to Shutdown or Disable (in controller), the drive folds back the current when the I²T calculation indicates that the motor temperature has exceeded 10% of its rated temperature. If it is set to Stop Motion or Status Only, the drive does not fold back the current. The I²T calculation never generates a fault.
- (2) The Logix5000 Drive Thermal Fault Action is tied to the drive thermostat fault. The drive always folds back the current when the I²T calculation indicates that the drive has exceeded 110% of its rating. The I²T calculation never generates a fault.

Removing and Replacing the Kinetix 6000 Drive Modules

This chapter provides remove and replace procedures for your Kinetix 6000 system components.

Topic	Page
Before You Begin	179
Remove Kinetix 6000 Drive Modules	180
Replace Kinetix 6000 Drive Modules	181
Remove the Power Rail	182
Replace the Power Rail	183



ATTENTION: This drive contains electrostatic discharge (ESD) sensitive parts and assemblies. You are required to follow static-control precautions when you install, test, service, or repair this assembly. If you do not follow ESD control procedures, components can be damaged. If you are not familiar with static control procedures, refer to Guarding Against Electrostatic Damage, publication [8000-4.5.2](#), or any other applicable ESD awareness handbook.

Before You Begin

These tools are required before you begin removal and replacement procedures:

- Flat-blade screwdriver, 3.5 mm (0.14 in.)
- Voltmeter

Remove Kinetix 6000 Drive Modules

Follow these steps to remove the IAM, AM, and IPIM modules from the Bulletin 2094 power rail.

1. Verify that all control and input power has been removed from the system.



ATTENTION: To avoid shock hazard or personal injury, assure that all power has been removed before proceeding. This system can have multiple sources of power. More than one disconnect switch can be required to de-energize the system.

2. Wait five minutes for the DC bus to discharge completely before proceeding.



ATTENTION: This product contains stored energy devices. To avoid hazard of electrical shock, verify that all voltage on capacitors has been discharged before attempting to service, repair, or remove this unit. Do not attempt the procedures in this document unless you are qualified to do so and are familiar with solid-state control equipment and the safety procedures in publication NFPA 70E.

3. Label and remove all connectors from the IAM/AM module you are removing.

To identify each connector, refer to [page 58](#).

4. Remove the motor cable from the cable shield clamp, as shown in these examples.

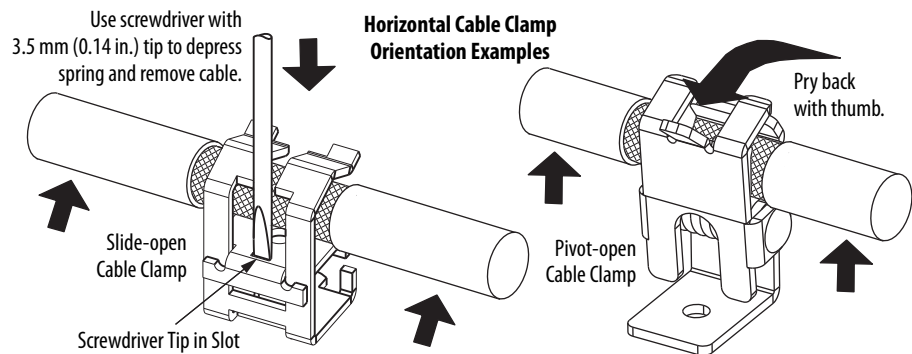
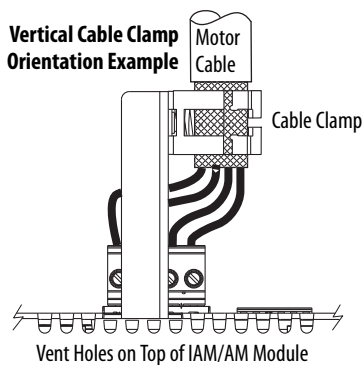

5. Loosen the mounting screw (bottom center of each module).
6. Grasp the top and bottom of the module with both hands and gently pull the module away from the connectors enough to clear the guide pins (module pivots on top bracket).

- Lift the bracket out of the power rail slot and remove the module from the power rail.

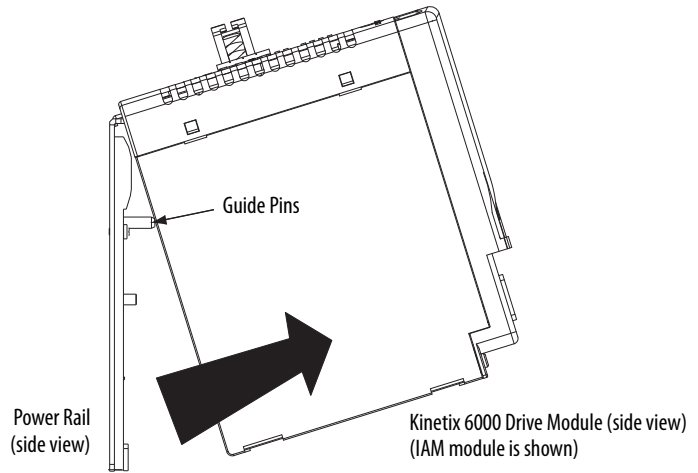

TIP This procedure also applies to Bulletin 2094-BSP2 shunt module, 2094-PRF slot-filler module, and 2094-SEPM-B24-S IPIM module.

Replace Kinetix 6000 Drive Modules

Follow these steps to replace drives from the Bulletin 2094 power rail.

- Determine your drive module replacement.

If you are	Then
Replacing a drive module on an existing power rail	Go to step 3 .
Replacing a drive module on a new power rail	Go to step 2 .

- Prepare to mount your replacement drive module by removing the protective covers from the power rail connectors.
- Hang the mounting bracket from the slot on the power rail.

IMPORTANT Power rails must be in vertical orientation before replacing drive modules for pins to seat properly.

- Align the guide pins on the power rail with the guide pin holes in the back of the drive module (refer to the figure above).

TIP The IAM module can have two or three power rail connectors and guide pins, the AM module can have one or two, all other modules have only one connector and one guide pin.

- Use 2.26 N•m (20 lb•in) torque to tighten the mounting screw.
- Reconnect the module connectors.
- Reapply power to the system.

8. Verify that the system is operating properly.

TIP Because parameter settings reside in the Logix Designer application, you do not need to perform any tuning or set-up procedures.

Remove the Power Rail

This procedure assumes you have removed all modules from the power rail.

Follow these steps to remove the power rail.

1. Disconnect the braided grounding strap from the grounding stud on the right side of the power rail.

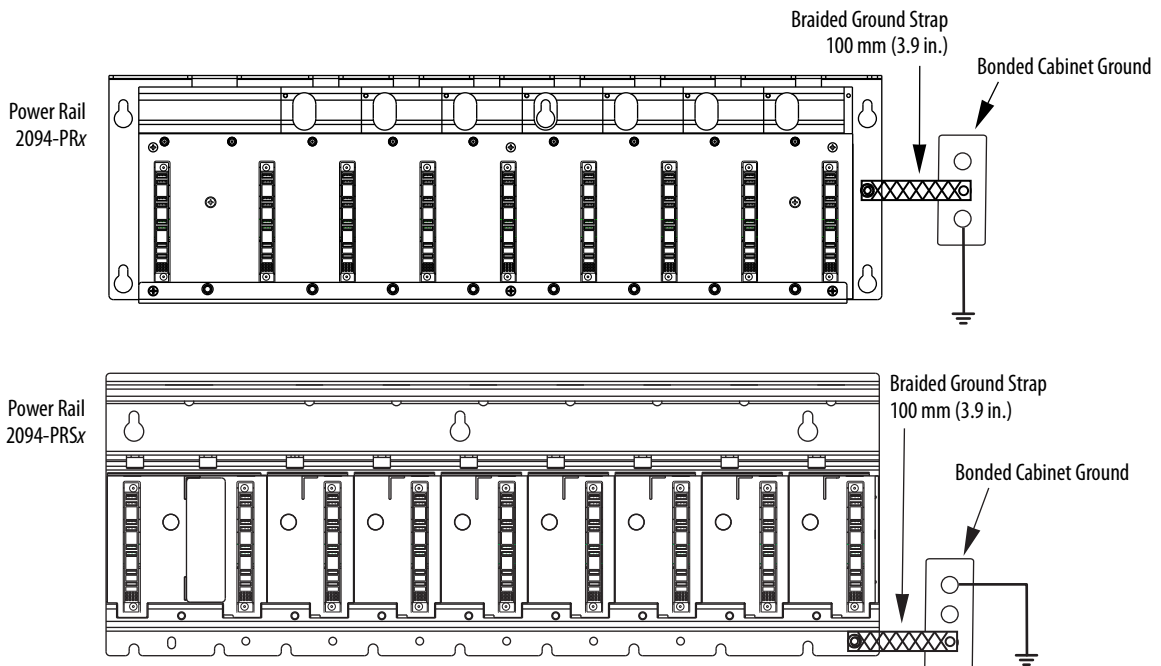

2. Loosen the mounting bolts (removing the bolts is not necessary).

3. Lift the power rail up and off of the mounting bolts.

Replace the Power Rail

This procedure assumes you do not need to change the location of the power rail on the panel and you intend to reuse the mounting bolts of the power rail you just removed.

IMPORTANT If you need to change the location of the power rail, or if you are installing a power rail designed for additional or fewer modules than you removed, refer to Kinetix 6000 Power Rail Installation Instructions, publication [2094-IN003](#).



ATTENTION: To avoid damage to the power rail during installation, do not remove the protective covers until the module for each slot is ready for mounting.

Follow these steps to replace the power rail.

1. Align the replacement power rail over the existing mounting bolts.

IMPORTANT To improve the bond between the power rail and subpanel, construct your subpanel out of zinc plated (paint-free) steel.

2. Tighten the mounting bolts.
3. Reattach the braided grounding strap to the power rail grounding stud (refer to [page 182](#)).

Notes:



Interconnect Diagrams

This appendix provides wiring examples and system block diagrams for your Kinetix 6000 system components.

Topic	Page
Interconnect Diagram Notes	186
Power Wiring Examples	187
DC Common Bus Wiring Examples	191
Shunt Module Wiring Examples	195
Axis Module/Rotary Motor Wiring Examples	196
Axis Module/Linear Motor/Actuator Wiring Examples	205
Kinetix 6000M Integrated Drive-Motor Wiring Example	210
Controlling a Brake Example	211
System Block Diagrams	212

Interconnect Diagram Notes

This appendix provides wiring examples to assist you in wiring the Kinetix 6000 drive system. These notes apply to the wiring examples on the following pages.

Note	Information
1	For power wiring specifications, refer to Power Wiring Requirements on page 95 .
2	For input fuse and circuit breaker sizes, refer to Circuit Breaker/Fuse Options on page 28 .
3	Place AC (EMC) line filters as close to the drive as possible and do not route very dirty wires in wireway. If routing in wireway is unavoidable, use shielded cable with shields grounded to the drive chassis and filter case. For AC line filter specifications, refer to the Kinetix Motion Accessories Technical Data, publication GMC-TD004 .
4	Terminal block is required to make connections.
5	2094-BCxx-Mxx-x (460V) IAM modules require a step down transformer for single-phase control power input. Source the 2094-ACxx-Mxx-x (230V) IAM module control power from the three-phase input power (line-to-line) with neither leg of the transformer secondary bonded to ground or neutral potential. Supplying control power from any other source requires an isolation transformer. The National Electrical Code and local electrical codes take precedence over the values and methods provided. Implementation of these codes is the responsibility of the machine builder.
6	2094-ALxxS and 2094-BLxxS and 2094-XL75S-C2 LIM modules can supply input power for up to eight axes. 2094-XL75S-C1 LIM modules can supply input power for up to sixteen axes. For common-bus systems with more than sixteen axes, multiple LIM modules (or control power transformers) are required. For Kinetix 6000M systems, the control power current needs to be calculated and the LIM module needs to be sized.
7	2094-ALxxS, 2094-BLxxS, and 2094-XL75S-Cx LIM modules are capable of connecting to two IAM modules, providing each IAM module has its own line filter and the maximum current specification is not exceeded.
8	Contacting coil (M1) needs integrated surge suppressors for AC coil operation. Refer to the Kinetix Servo Drives Technical Data, publication GMC-TD003 .
9	Drive Enable input must be opened when main power is removed, or a drive fault occurs. A delay of at least 1.0 second must be observed before attempting to enable the drive after main power is restored.
10	Cable shield clamp must be used to meet CE requirements. No external connection to ground is required.
11	Default configuration for jumper is for grounded power at user site. Ungrounded sites must jumper the bleeder resistor to prevent high electrostatic buildup. Refer to Determine the Input Power Configuration on page 83 for more information.
12	Leave jumper between PR2 and PR3 as shown to use the internal pre-charge resistor. Remove jumper when external pre-charge/circuit is required. For more information, refer to the 8720MC Regenerative Power Supply Installation Manual, publication 8720MC-RM001 .
13	 ATTENTION: Implementation of safety circuits and risk assessment is the responsibility of the machine builder. Please reference international standards EN 1050 and EN 954 estimation and safety performance categories. For more information refer to Understanding the Machinery Directive, publication SHB-900 .
14	 ATTENTION: Wiring the contactor enable relay is required. Refer to Contactor Enable Relay on page 70 , for more information. The recommended minimum wire size for wiring the safety circuit to the contactor enable connector is 1.5 mm ² (16 AWG).
15	The Bulletin 2094 axis module referenced is either an individual axis module (catalog number 2094-xMxx-x) or the same axis module that resides within an integrated axis module (catalog number 2094-xCxx-Mxx-x).
16	For motor cable specifications, refer to the Kinetix Motion Accessories Technical Data, publication GMC-TD004 .
17	Wire colors are for flying-lead cable and can vary from the premolded cable connectors.
18	Motor power cables (2090-XXNPMF-xxSxx and 2090-CPBM6DF-16AAxx) have a drain wire that must be folded back under the cable shield clamp.
19	MPL-A15xx...MPL-A45xx, MPM-A115xx...MPM-A130xx, MPF-A3xx...MPF-A45xx, MPS-Axxx, MPAR-Axxx, and MPAS-Axxx encoders use the +5V DC supply.
20	MPL-Bxx, MPL-A5xx, MPM-Bxx, MPM-A165xx...MPM-A215xx, MPF-Bxx, MPF-A5xx, MPS-Bxxx, MPAR-Bxxx, and MPAS-Bxxx encoders use the +9V DC supply.
21	Brake connector pins are labeled plus (+) and minus (-) or F and G respectively. Power connector pins are labeled U, V, W, and GND or A, B, C, and D respectively.

Power Wiring Examples

These examples apply to power wiring configurations with and without the Bulletin 2094 line interface module (LIM), DC common bus wiring, and shunt module wiring.

Figure 87 - Single IAM Module with 2094-AL09 or 2094-BL02 LIM Module

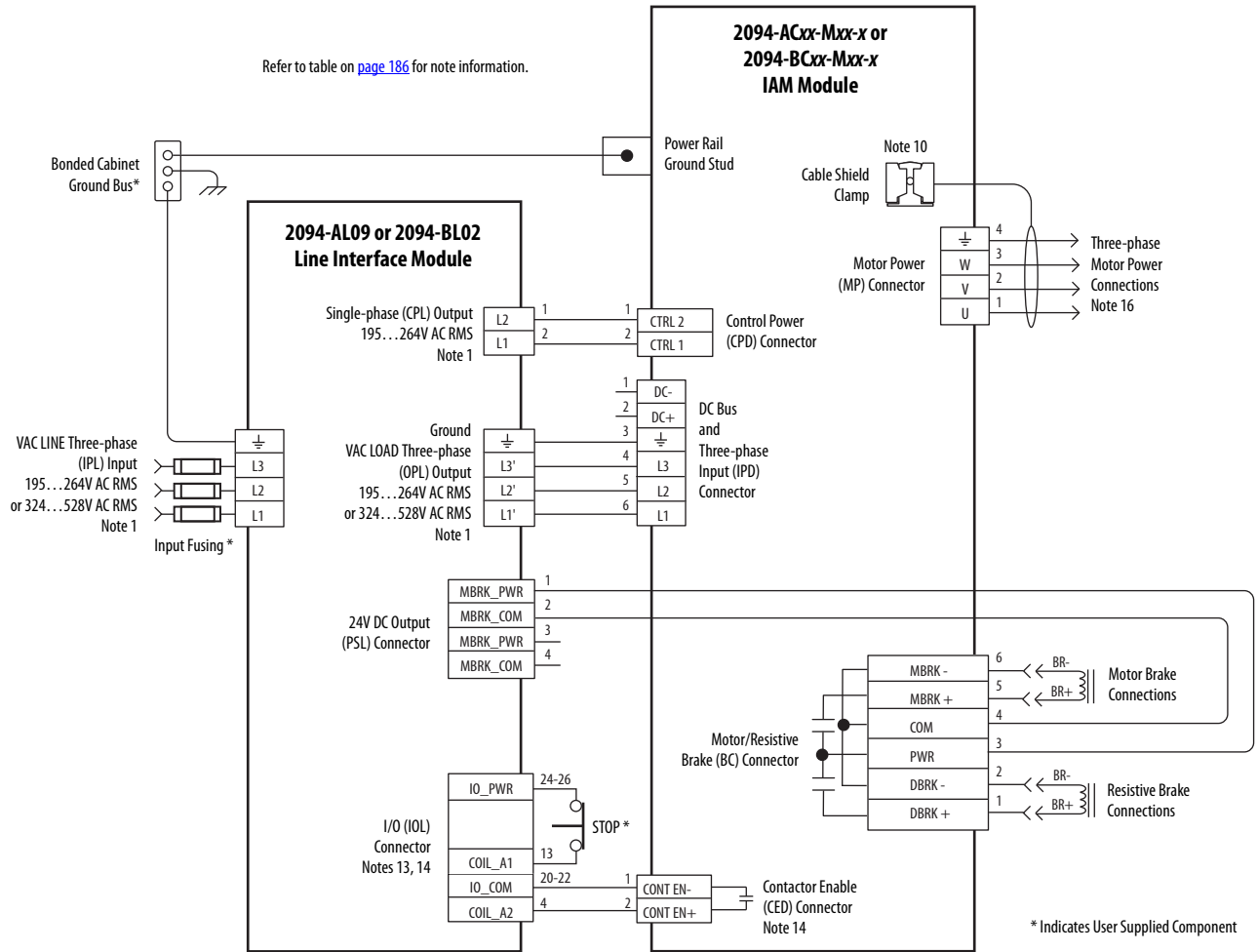

Figure 88 - Multiple IAM Module with LIM Module

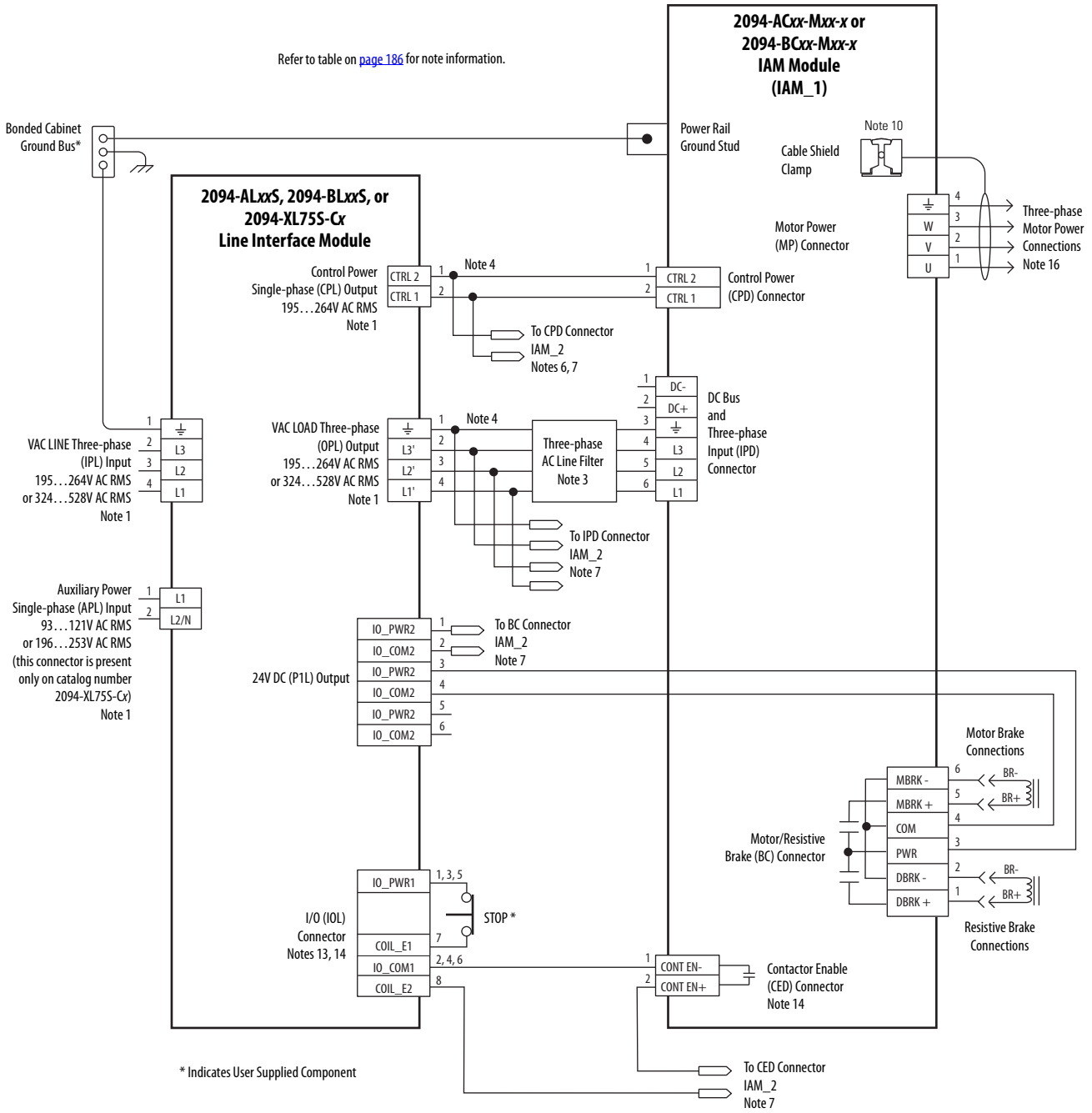
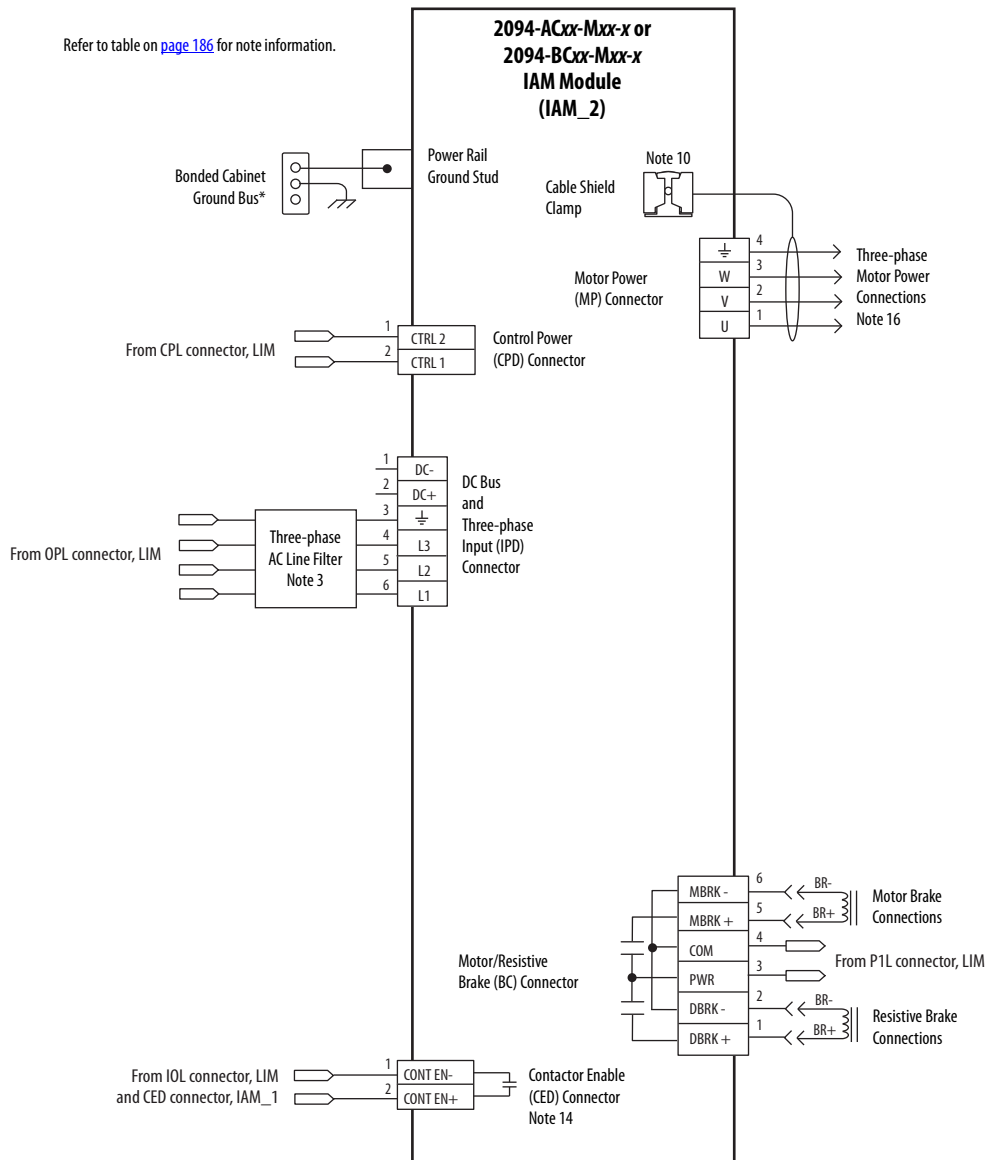

Figure 89 - Multiple IAM Module with LIM Module (continued)



This configuration does not include a LIM module. You must supply input power components. The single-phase and three-phase line filters are wired downstream of fusing and the M1 contactor.



ATTENTION: Wiring the contactor enable (CED) relay is required. To avoid injury or damage to the drive, wire the contactor enable relay into your safety control string.

Refer to Contactor Enable Relay on [page 70](#) for more information.

Figure 90 - IAM Module (without LIM module)

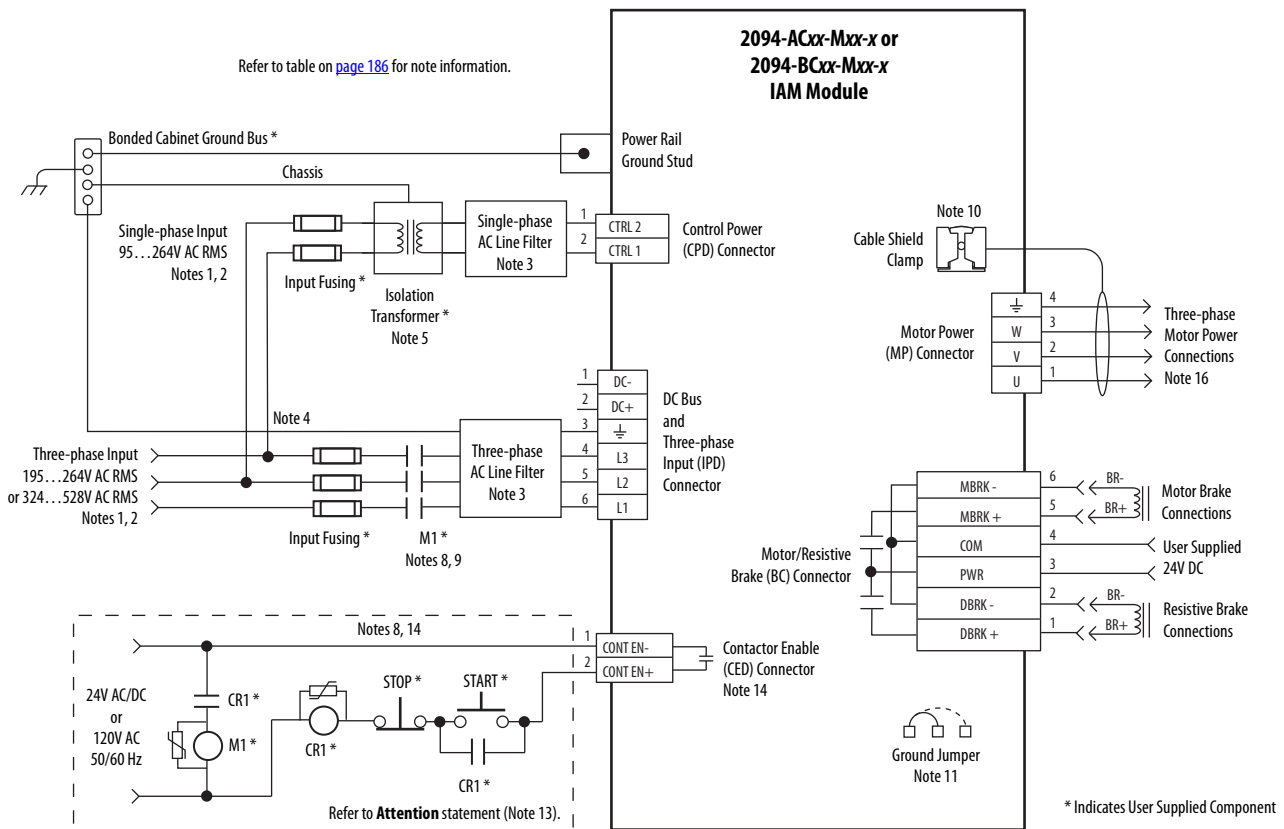

DC Common Bus Wiring Examples

Figure 91 - Leader IAM Module with Single Follower IAM Module

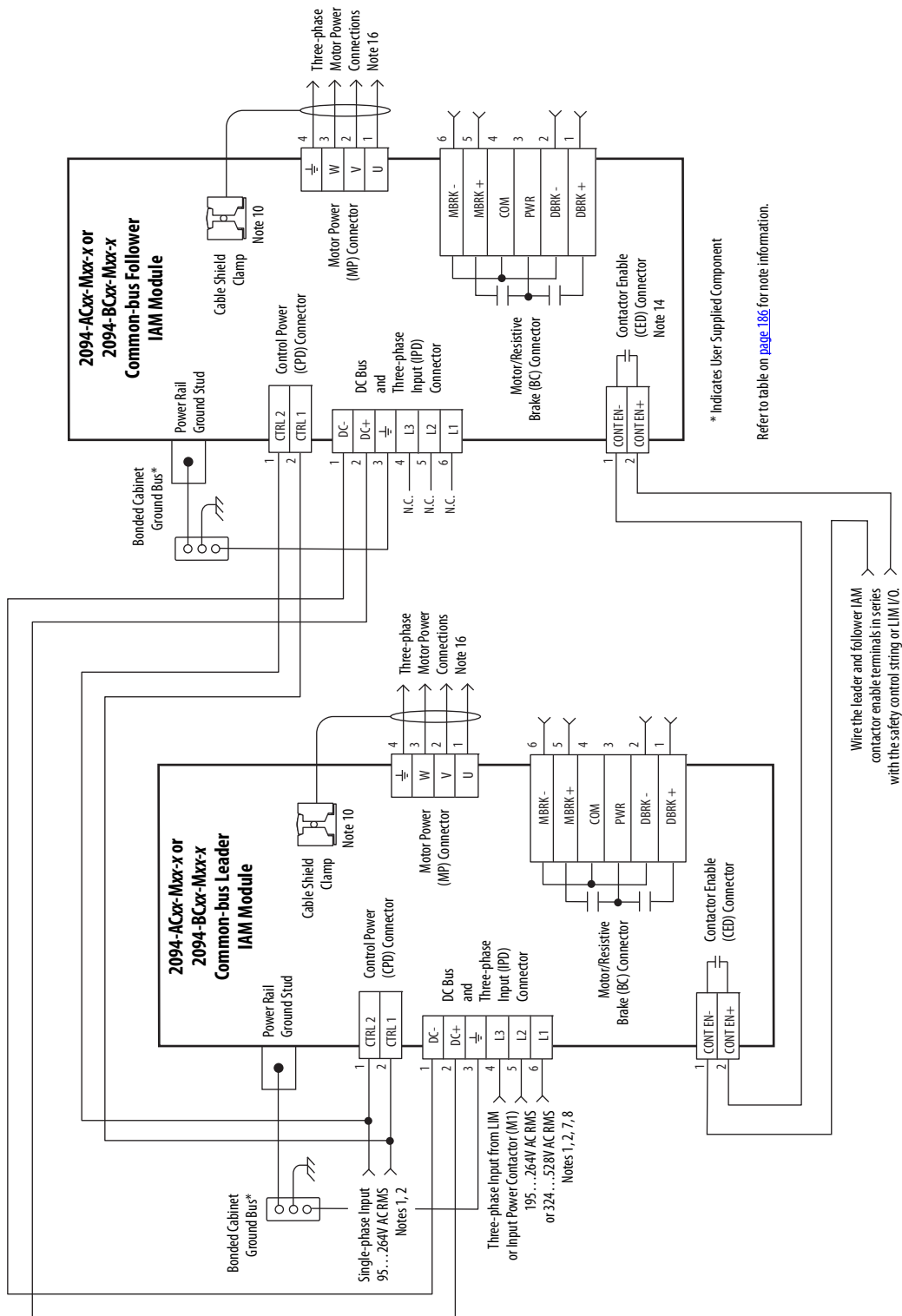

Figure 92 - Leader IAM Module with Multiple Follower IAM Modules

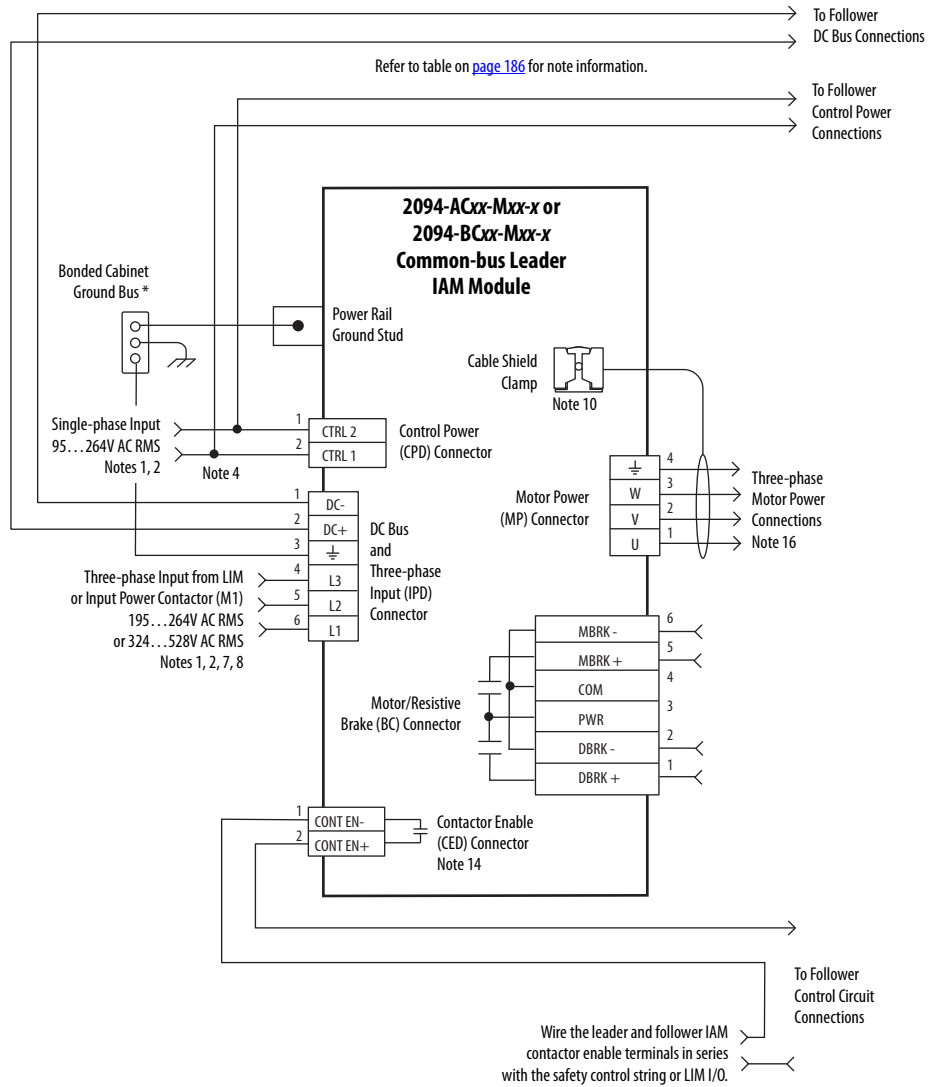

Figure 93 - Leader IAM Module with Multiple Follower IAM Modules (continued)

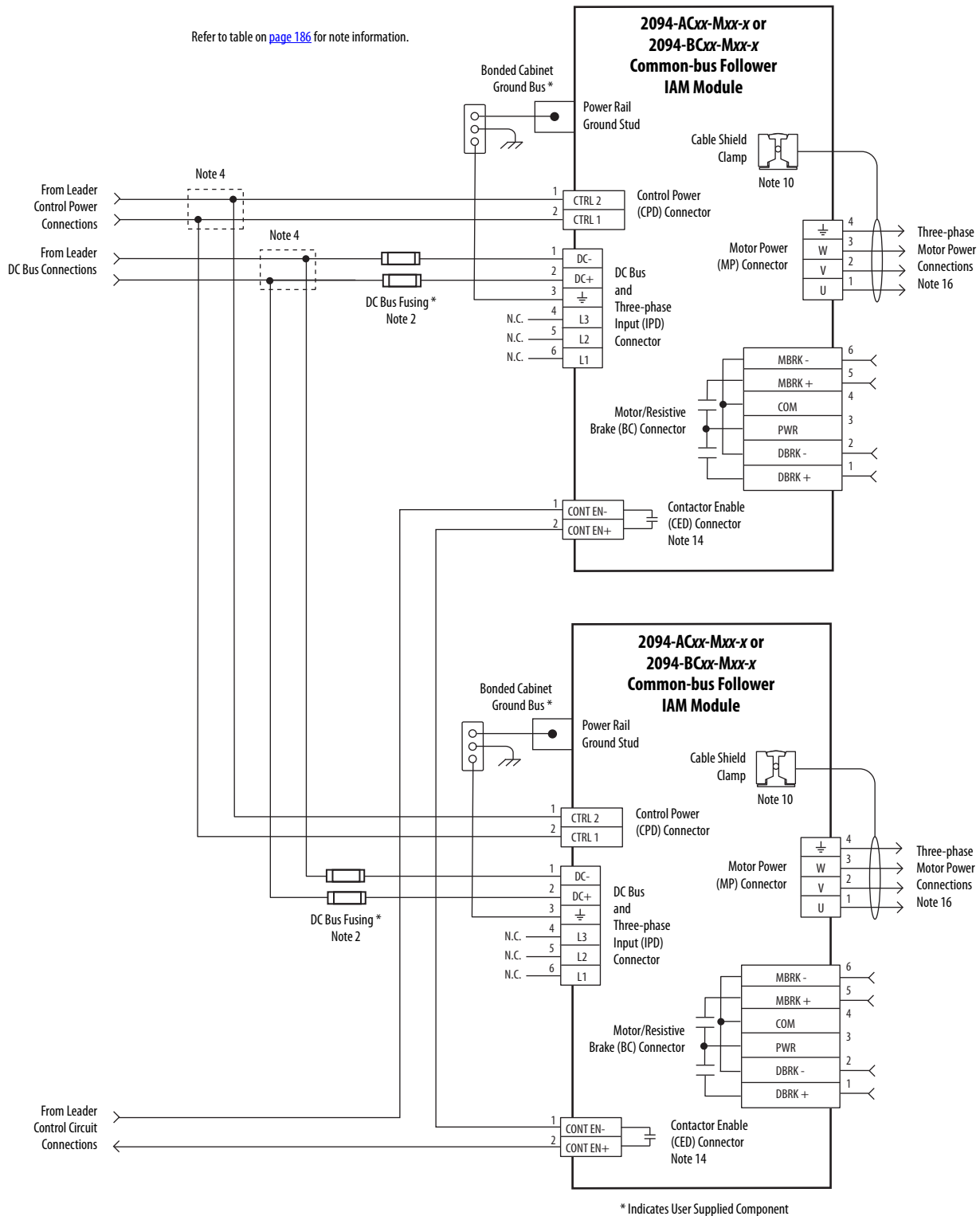
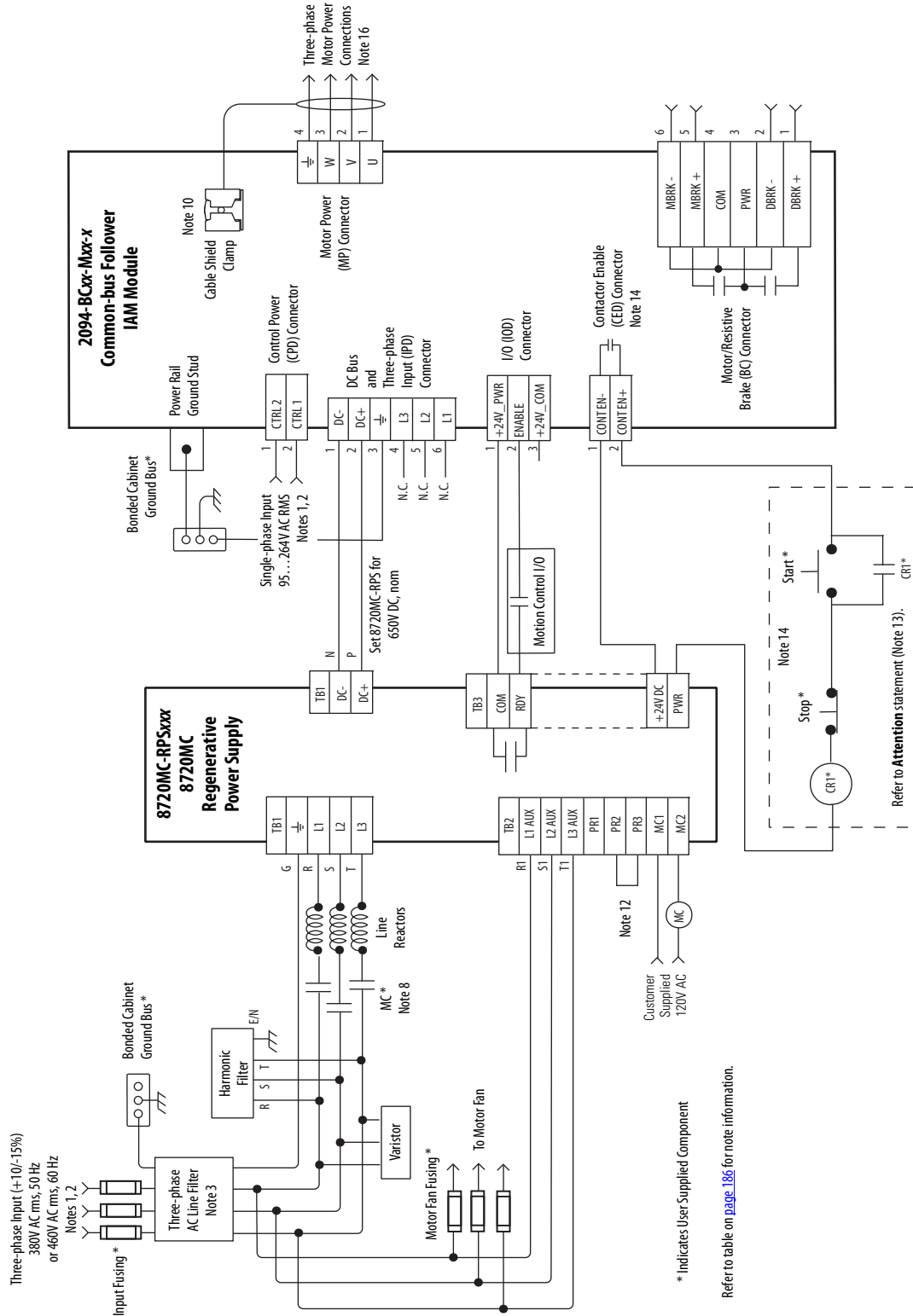

Figure 94 - 8720MC-RPS Leader Drive with Single Follower IAM Module



IMPORTANT Use a push button circuit (instead of an SPST toggle switch) in series with the contactor enable string (between the 8720MC-RPS and Kinetix 6000 drive) to allow a drive fault to remove the DC bus power, and to prevent the drive from applying DC bus power without your input after clearing a drive fault.

Shunt Module Wiring Examples

Refer to Kinetix Motion Accessories Technical Data, publication [GMC-TD004](#) for the Bulletin 1394 external shunt module catalog numbers available for the Kinetix 6000 drive systems.

Figure 95 - Shunt Module Wired for Internal Operation (default configuration)

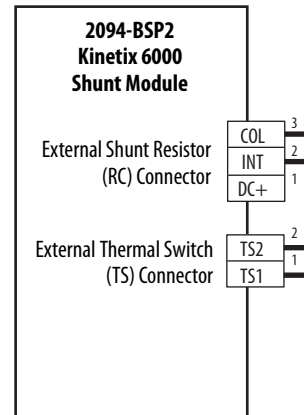

Refer to the Kinetix 6000 Shunt Module Installation Instructions, publication [2094-IN004](#), for additional installation information.

Figure 96 - Shunt Module with External Passive Shunt

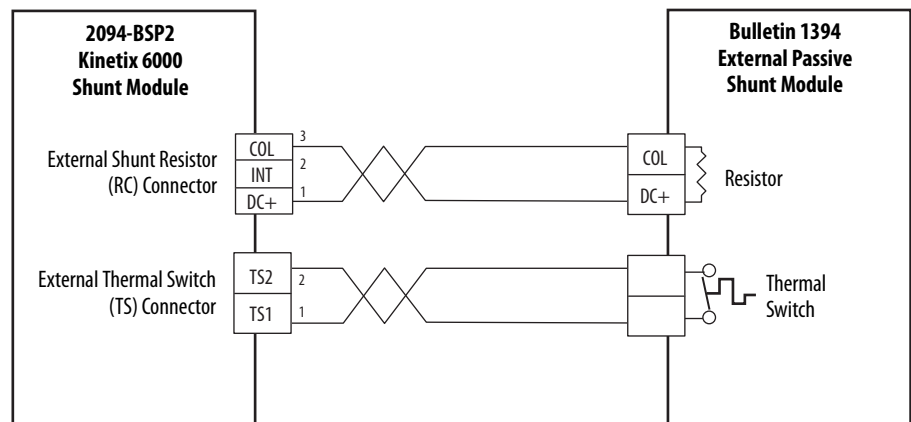

IMPORTANT Only passive shunts with a thermal switch are wired to the TS connector on the Kinetix 6000 shunt module. If your external passive shunt does not have a thermal switch, leave the jumper (default configuration) in place on the TS connector.

Refer to the External Shunt Module Installation Instructions, publication [2090-IN004](#), for additional installation information.

Axis Module/Rotary Motor Wiring Examples

These examples apply to Kinetix 6000 drives with Allen-Bradley rotary motors.

IMPORTANT The Bulletin MPL motor wiring examples on this page apply to motors equipped with bayonet connectors.

Figure 97 - AM Module with MP-Series (Bulletin MPL-B) Rotary Motors

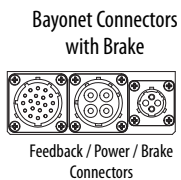
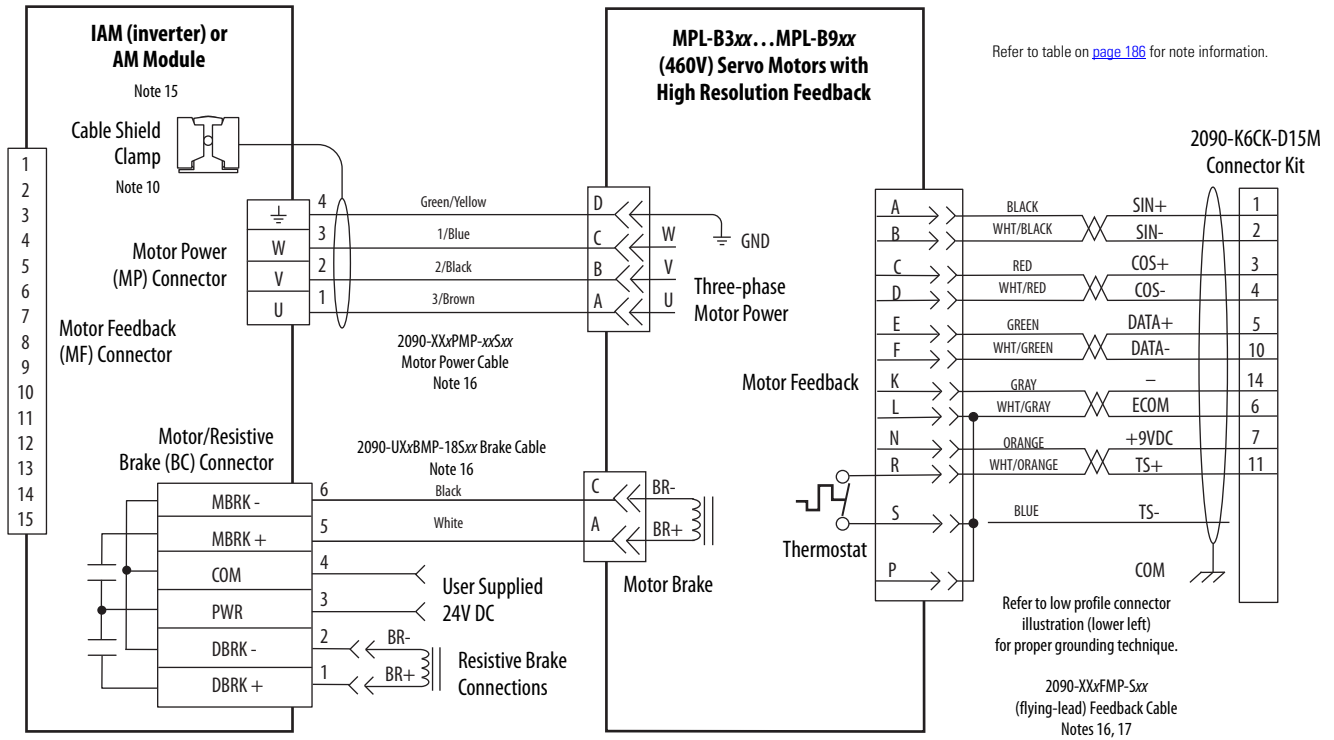

Grounding Technique for Feedback Cable Shield

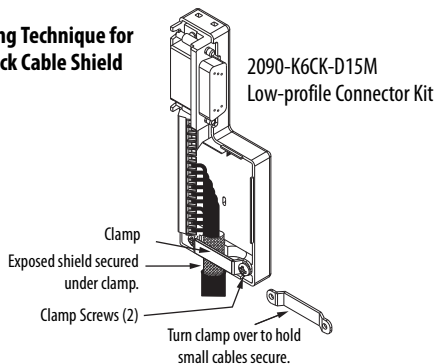

Refer to Low Profile Connector Kit Installation Instructions, publication [2094-IN007](#), for connector kit specifications.

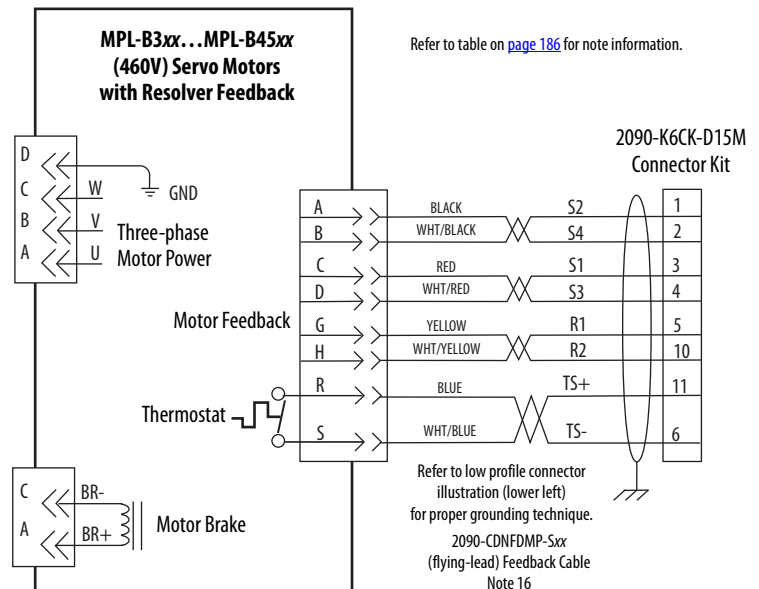

IMPORTANT The Bulletin MPL motor wiring examples on this page apply to motors equipped with bayonet connectors.

Figure 98 - AM Module Wiring Example with MP-Series (Bulletin MPL-A/B) Rotary Motors

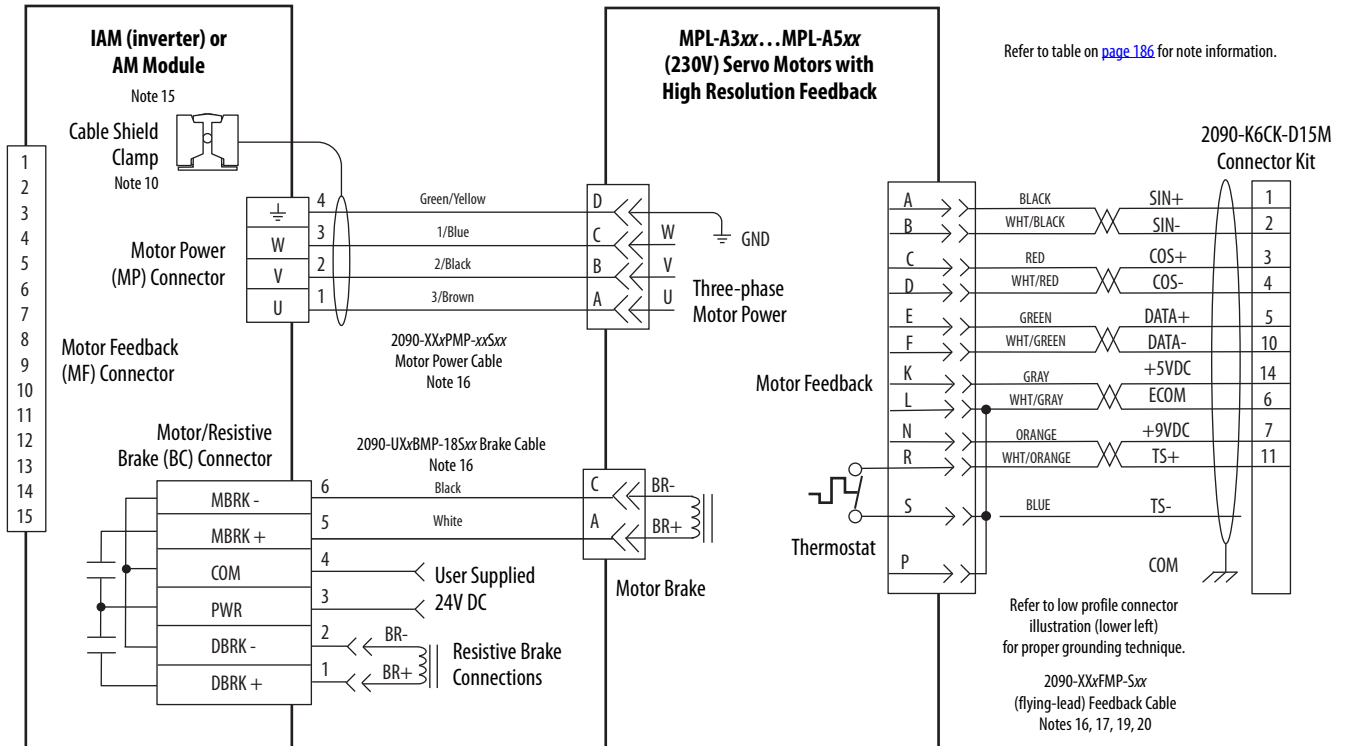

Bayonet Connectors with Brake

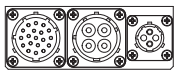

Feedback / Power / Brake Connectors

Bayonet Connectors without Brake

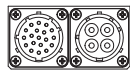

Feedback / Power Connectors

Grounding Technique for Feedback Cable Shield

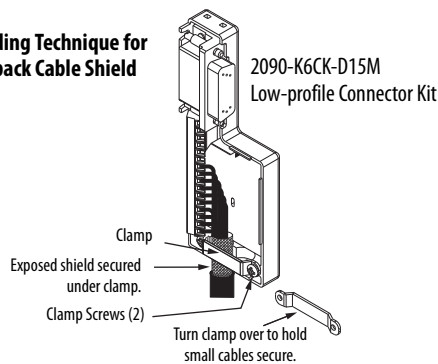

Refer to Low Profile Connector Kit Installation Instructions, publication [2094-IN007](#), for connector kit specifications.

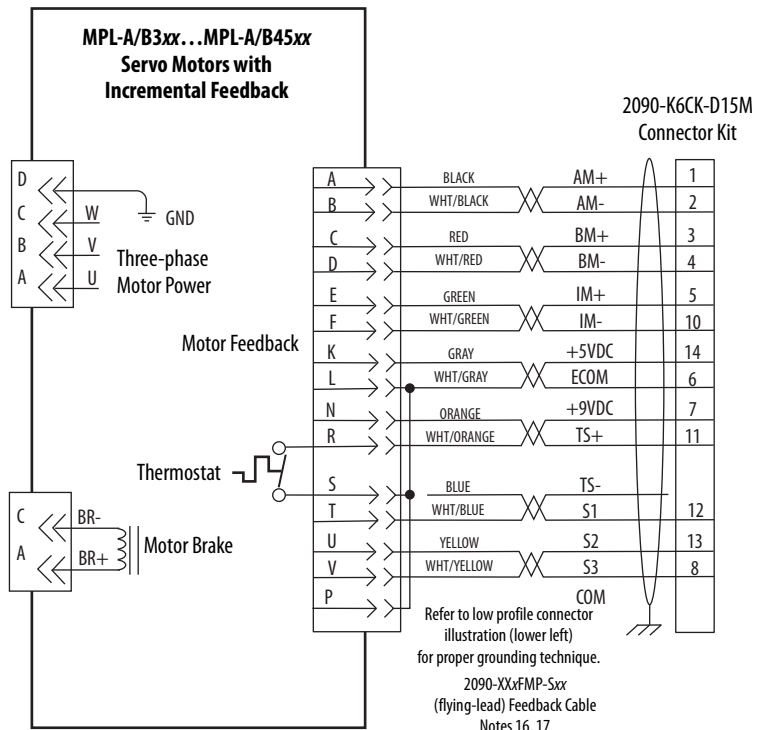

IMPORTANT The Bulletin MPL motor wiring examples on this page apply to motors equipped with circular DIN (threaded) connectors.

Figure 99 - AM Module with MP-Series (Bulletin MPL-A/B and MPS-A/B) Motors

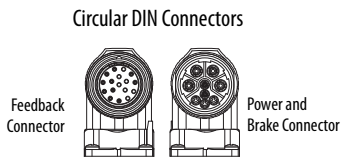
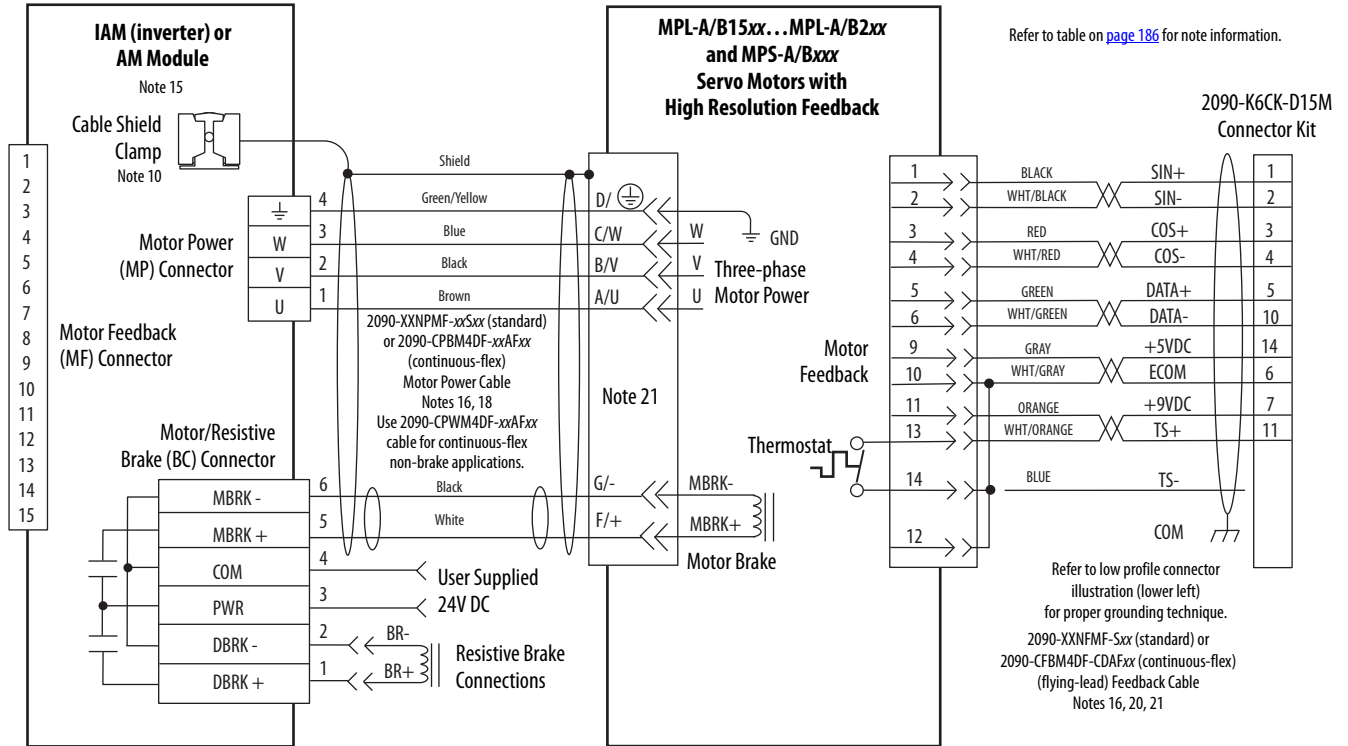

Grounding Technique for Feedback Cable Shield

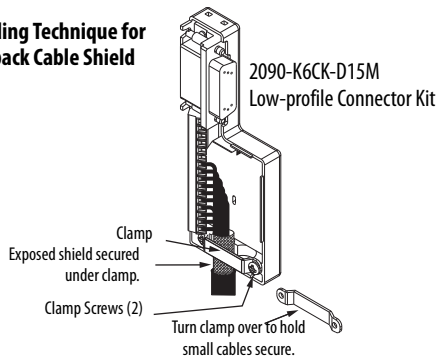

Refer to Low Profile Connector Kit Installation Instructions, publication [2094-IN007](#), for connector kit specifications.

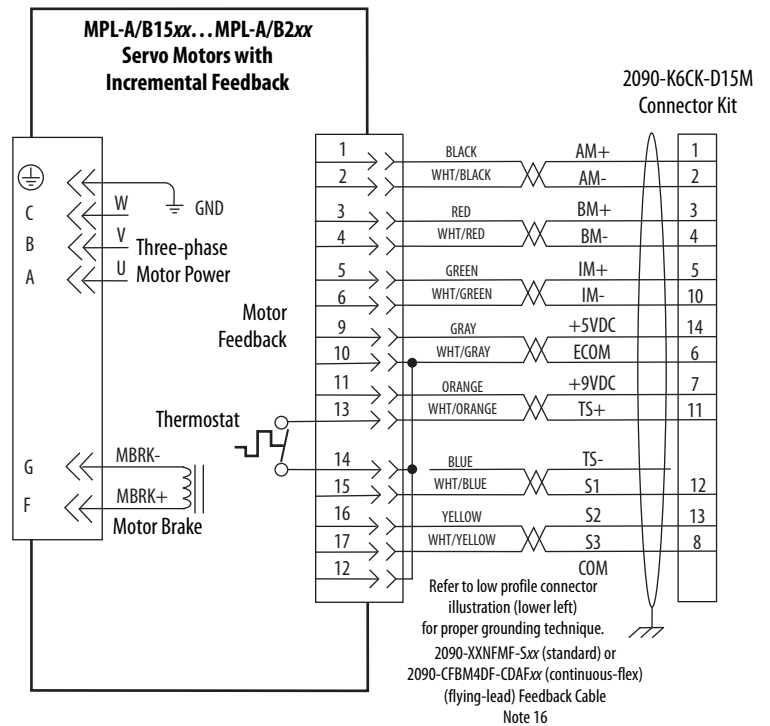

IMPORTANT The Bulletin MPL motor wiring examples on this page apply to motors equipped with circular DIN (SpeedTec) connectors.

Figure 100 - AM Module with MP-Series Motors (Bulletin MPL-A/B, MPM-A/B, and MPF-A/B)

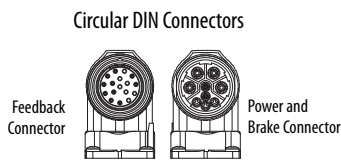
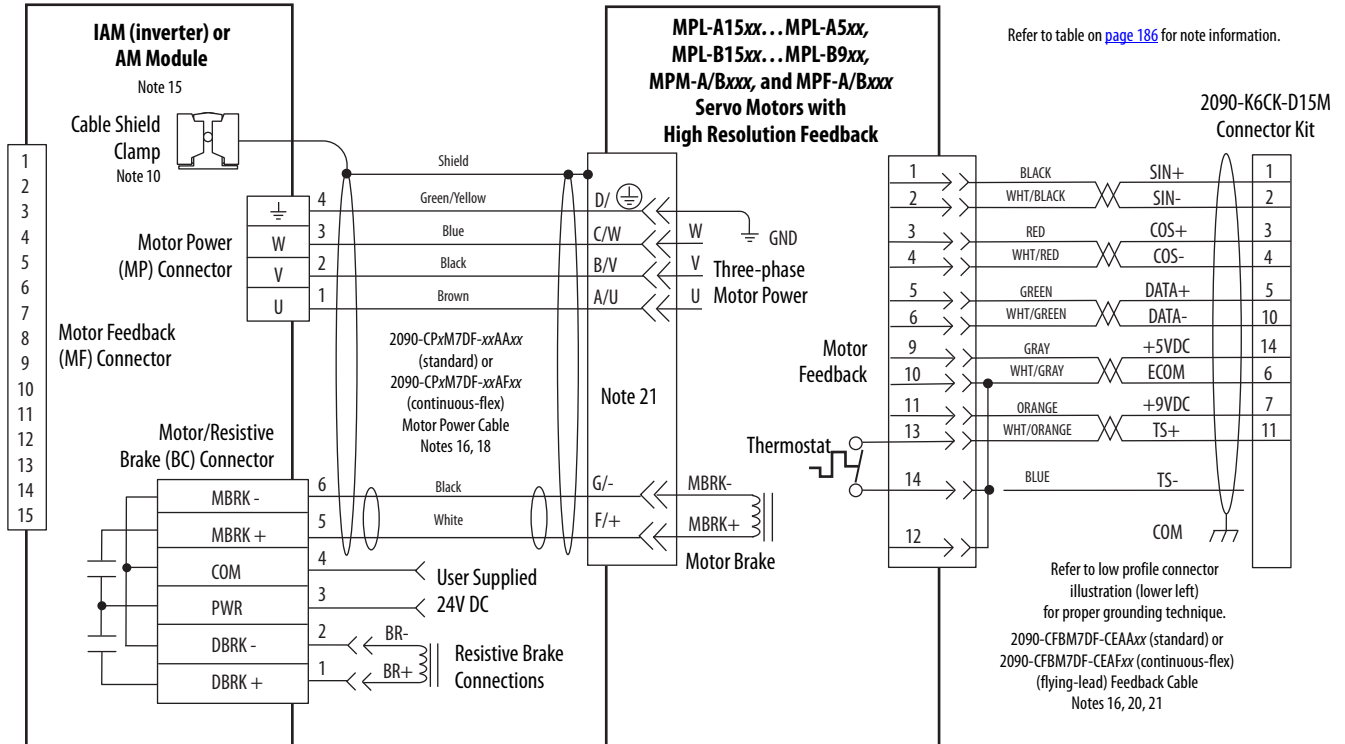

Grounding Technique for Feedback Cable Shield

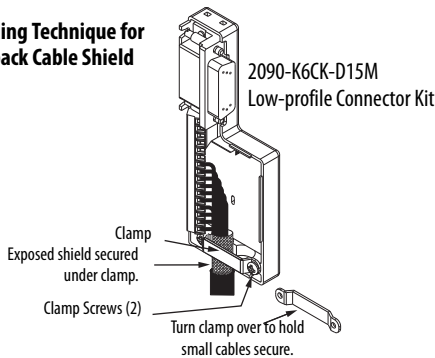

Refer to Low Profile Connector Kit Installation Instructions, publication [2094-IN007](#), for connector kit specifications.

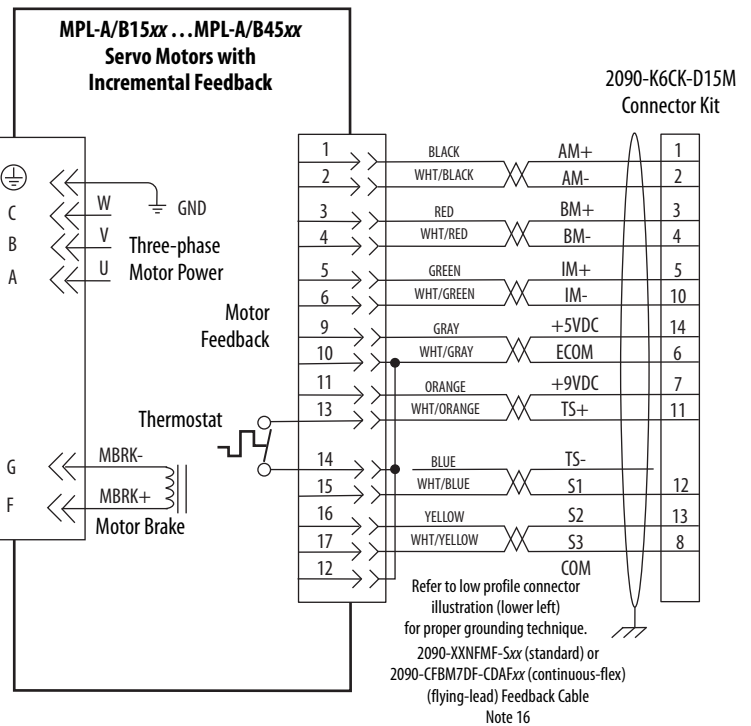

IMPORTANT The Bulletin MPL motor wiring examples on this page apply to motors equipped with circular DIN (SpeedTec) connectors.

Figure 101 - AM Module Wiring Example with MP-Series Resolver Motors (Bulletin MPL-B and MPM-A/B)

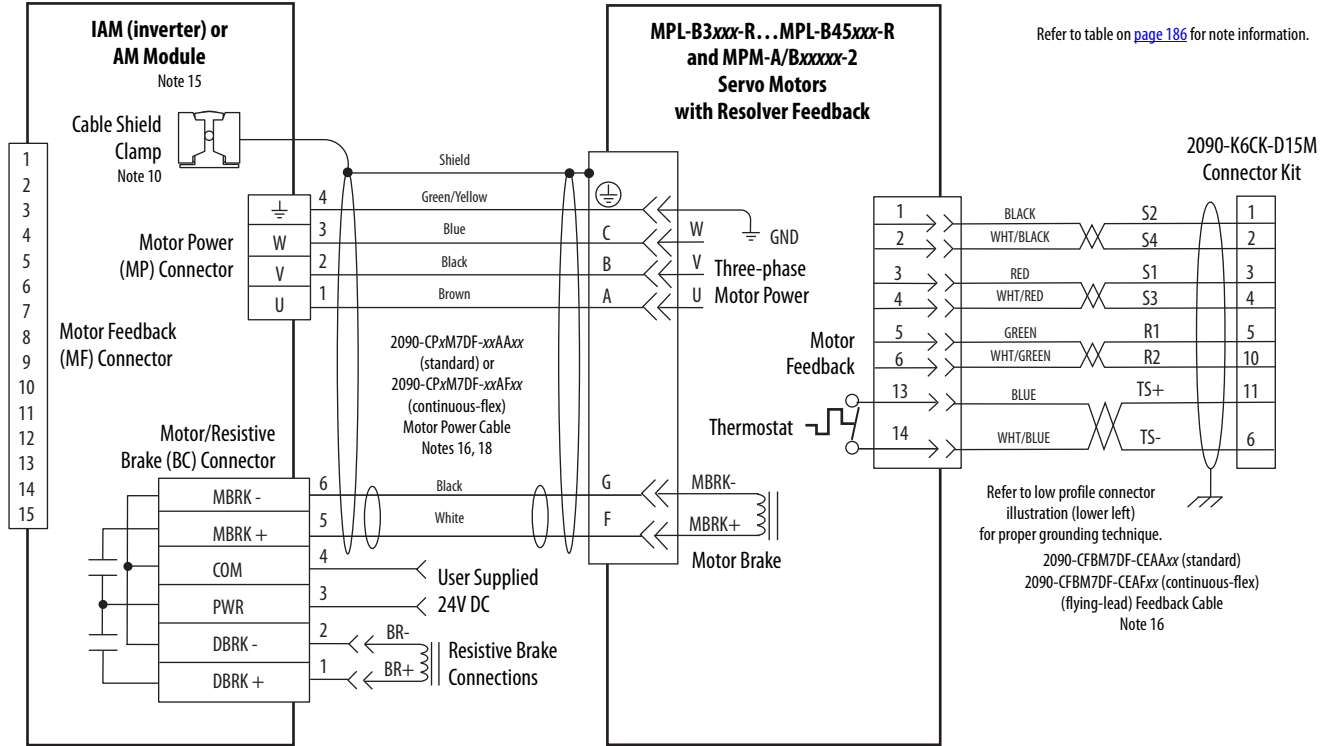

Circular DIN Connectors

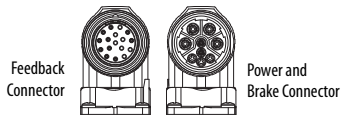

Grounding Technique for Feedback Cable Shield

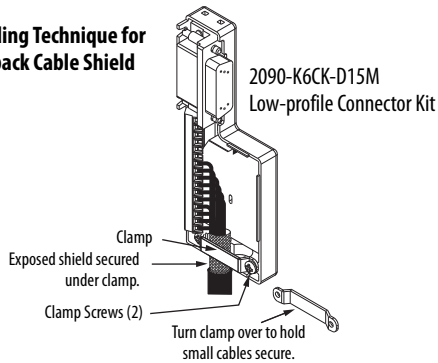

Refer to Low Profile Connector Kit Installation Instructions, publication [2094-IN007](#), for connector kit specifications.

Figure 102 - AM Module with RDD-Series Direct Drive Motors

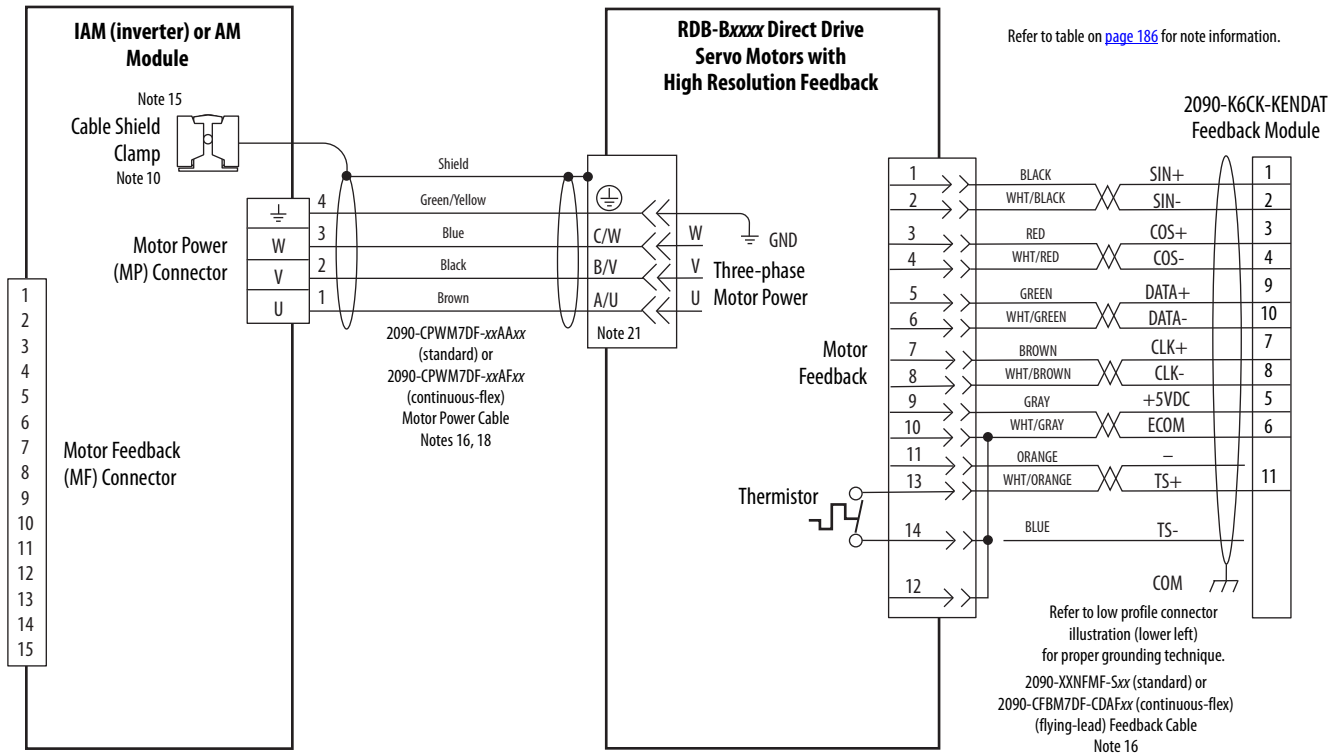

Grounding Technique for Feedback Cable Shield

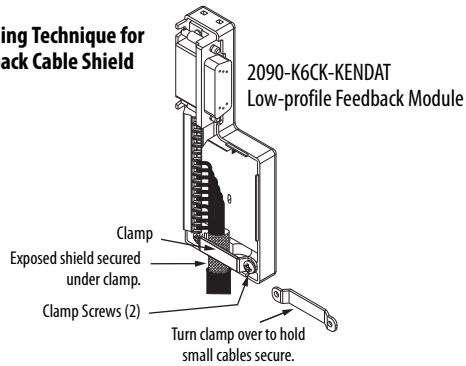

Refer to Low Profile EnDat Feedback Module Installation Instructions, publication [2090-IN020](#), for connector kit specifications.

Figure 103 - AM Module (230V) Wiring Example with TL-Series Motors (Bulletin TLY-A)

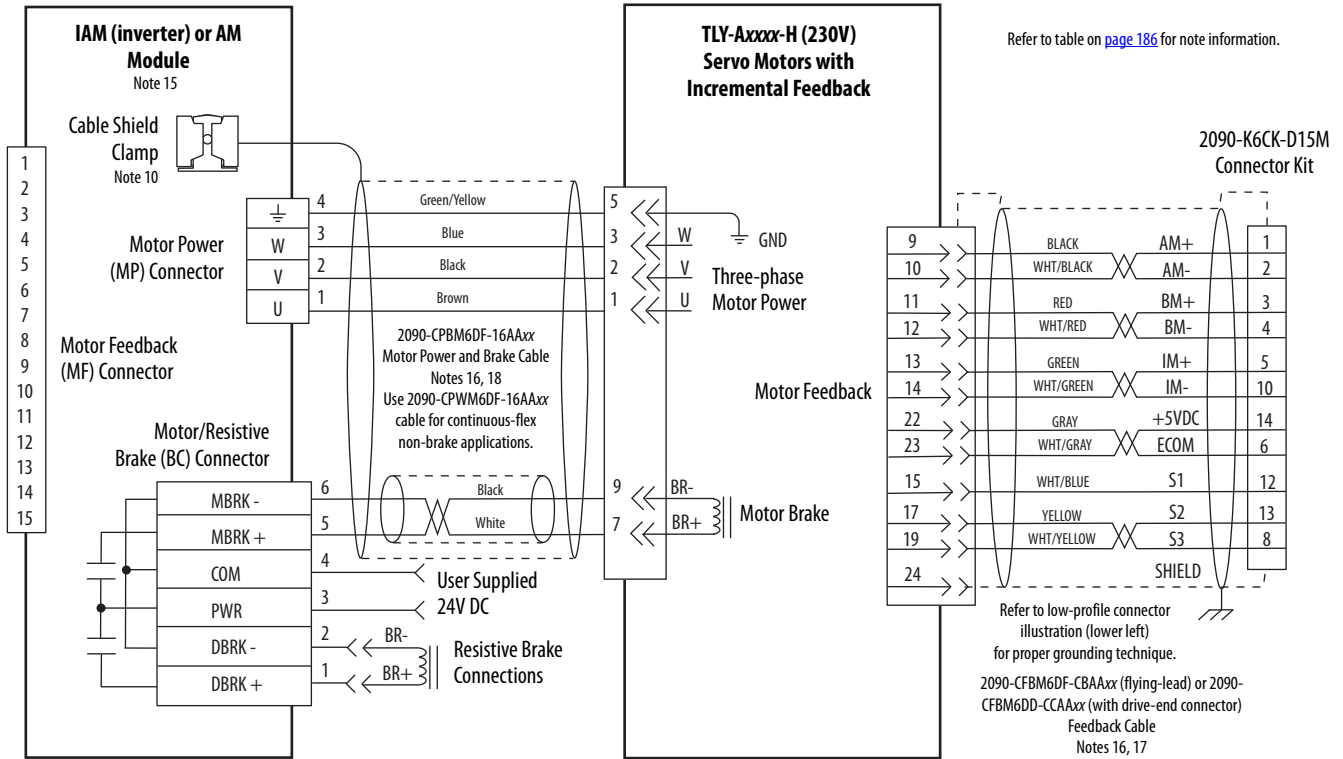

Grounding Technique for Feedback Cable Shield

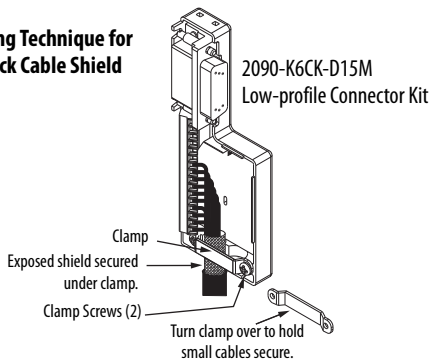

Refer to Low Profile Connector Kit Installation Instructions, publication [2094-IN007](#), for connector kit specifications.

Figure 104 - AM Module (460V) Wiring Examples with 1326AB Motors

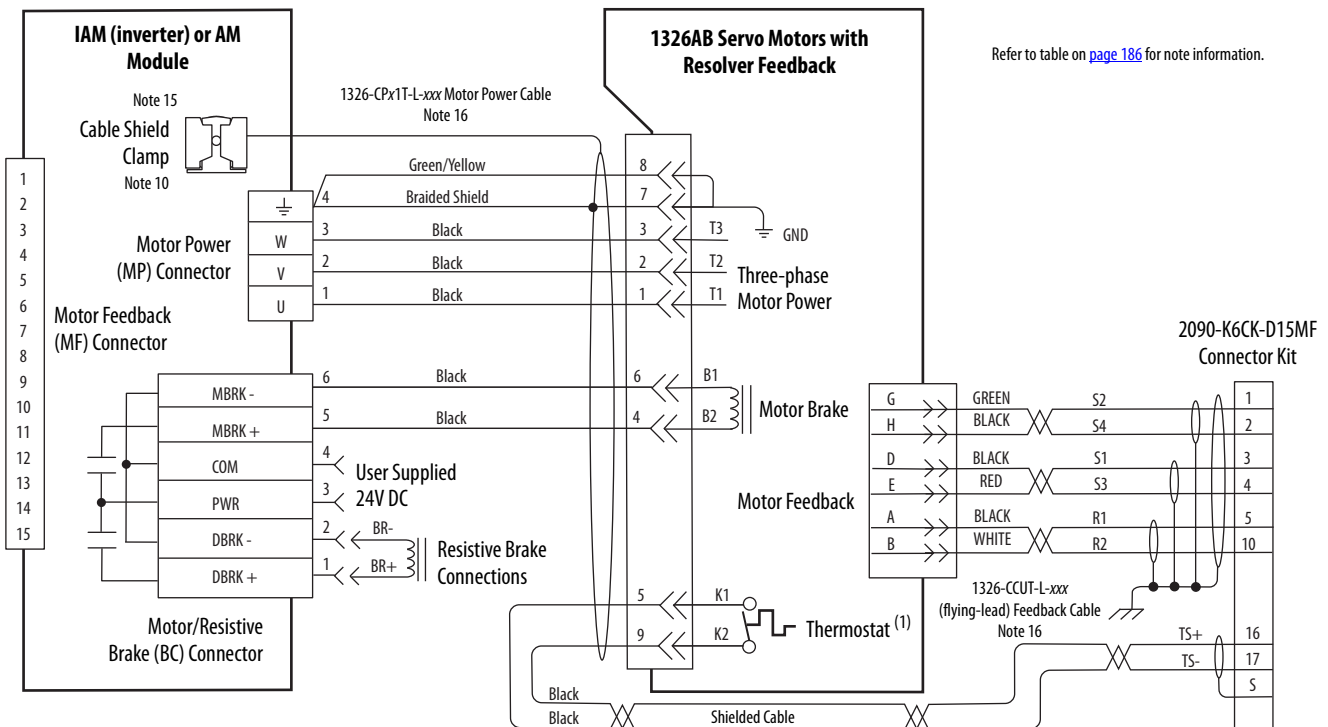
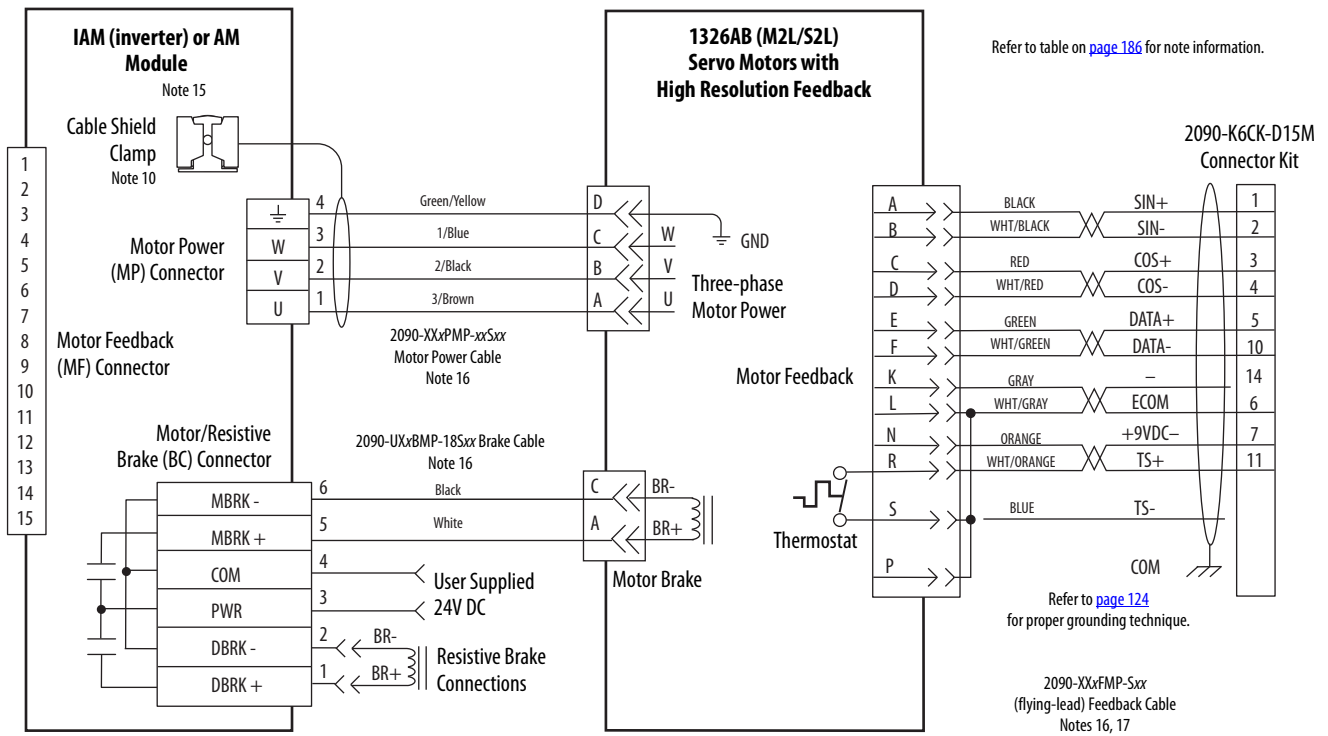

(1) When wiring the thermal switch on 1326AB (resolver-based) motors requires the use of the 2090-K6CK-D15MF Low-profile connector kit and wire extension to the power connector. Pins 16, 17, and 5 are filtered to prevent noise transmission back to the drive. Refer to [page 124](#) for wiring instructions and a diagram.

Figure 105 - AM Module (230V) Wiring Example with F-Series Motors

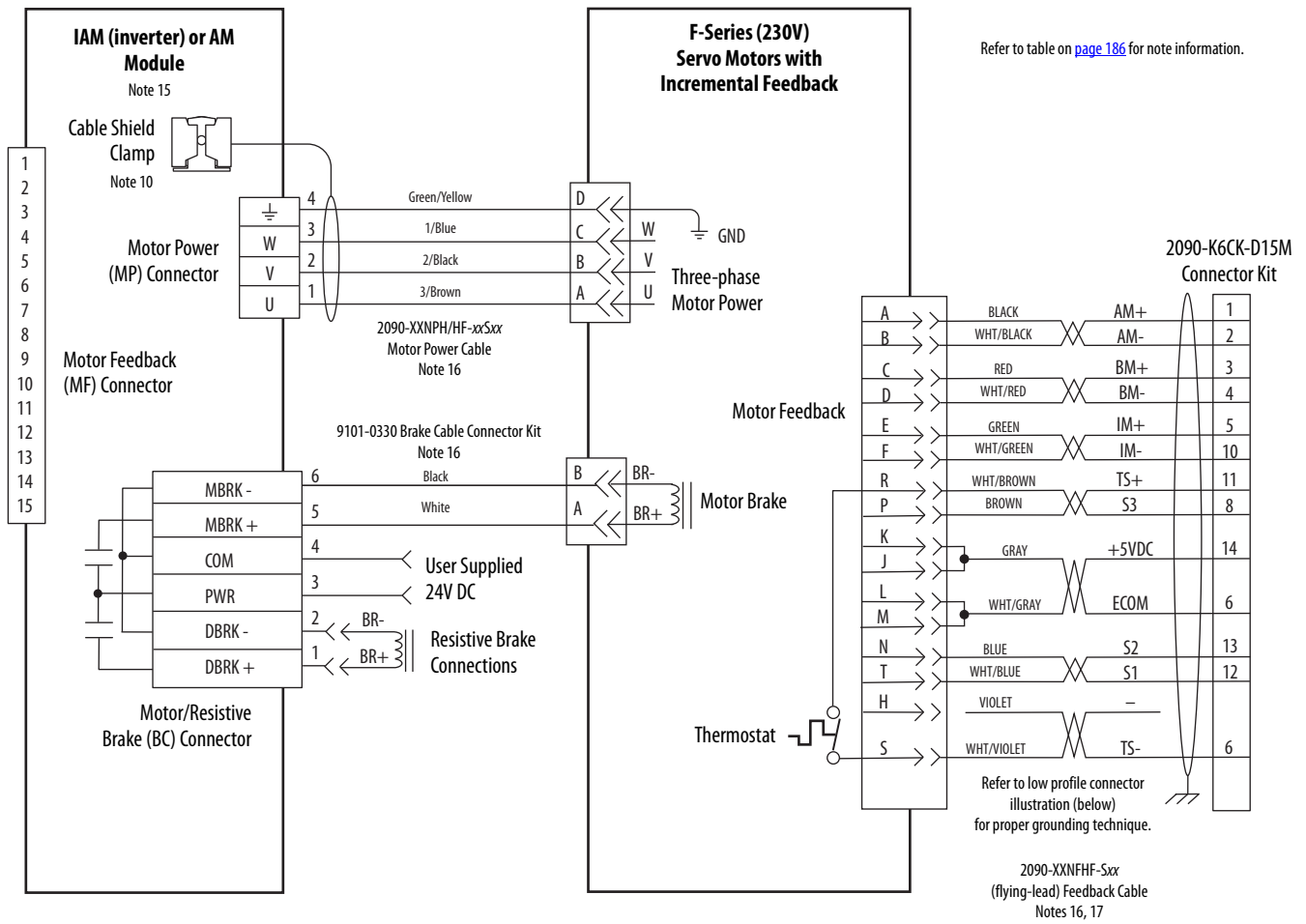

Grounding Technique for Feedback Cable Shield

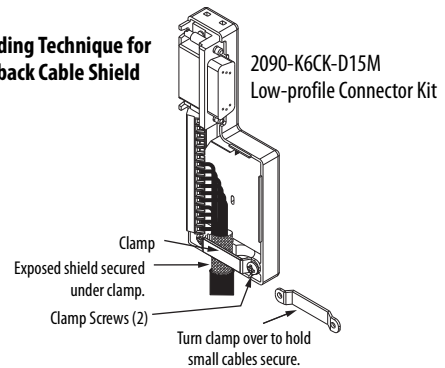

Refer to Low Profile Connector Kit Installation Instructions, publication [2094-IN007](#), for connector kit specifications.

Axis Module/Linear Motor/ Actuator Wiring Examples

These examples apply to Kinetix 6000 drives with Allen-Bradley linear motors and actuators.

Figure 106 - AM Module with MP-Series Integrated Linear Stages

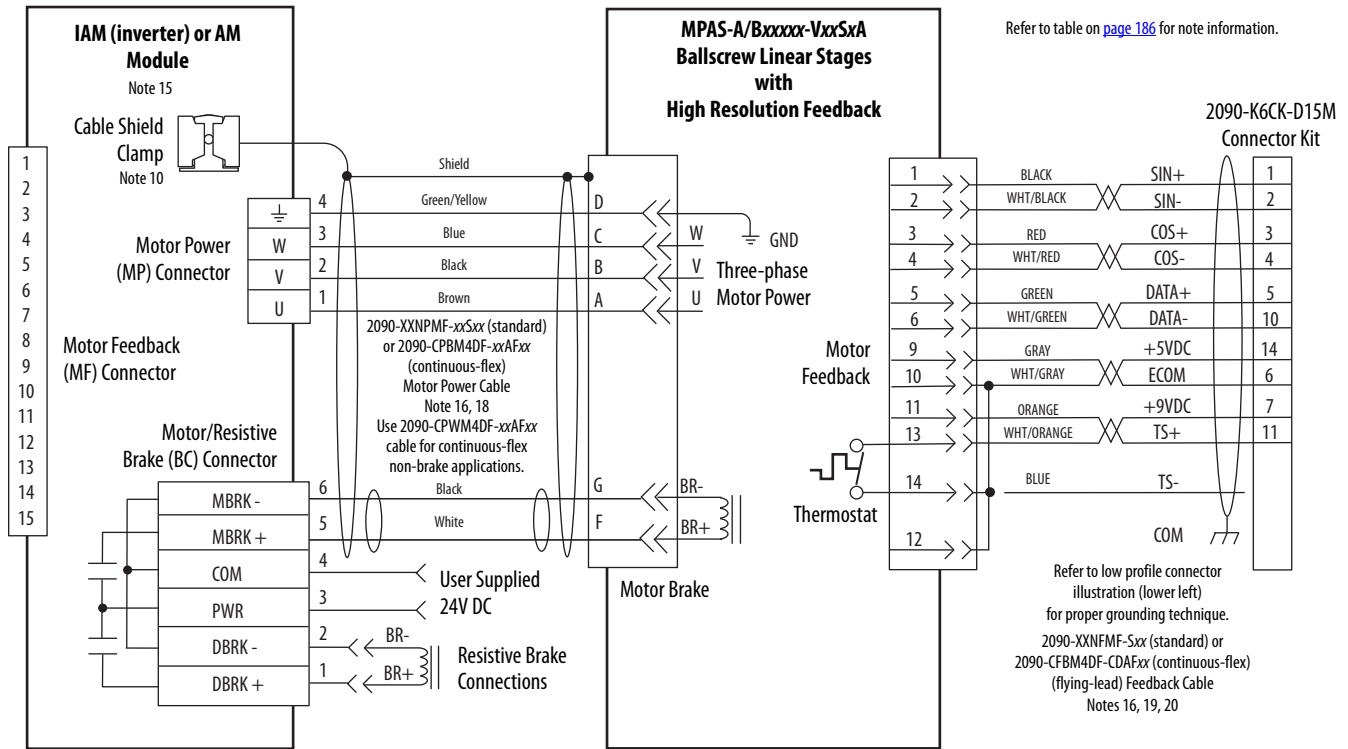

Grounding Technique for Feedback Cable Shield

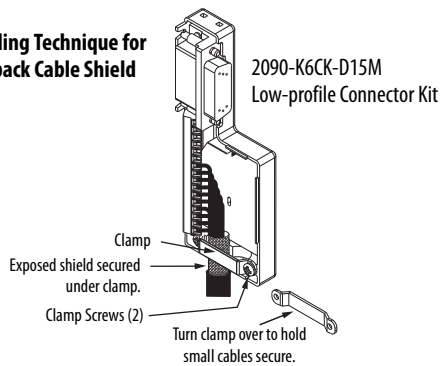

Refer to Low Profile Connector Kit Installation Instructions, publication [2094-IN007](#), for connector kit specifications.

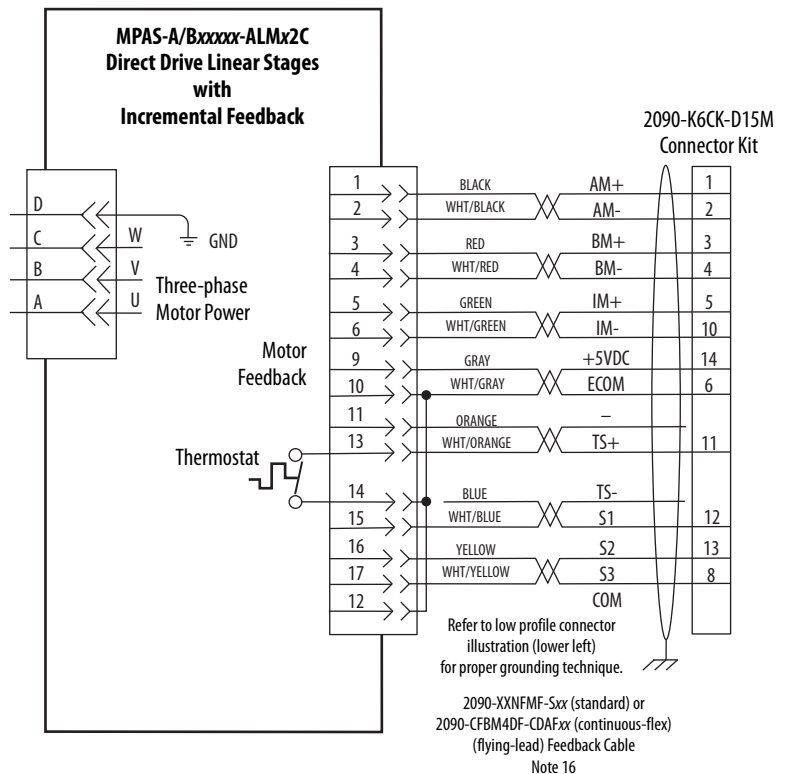
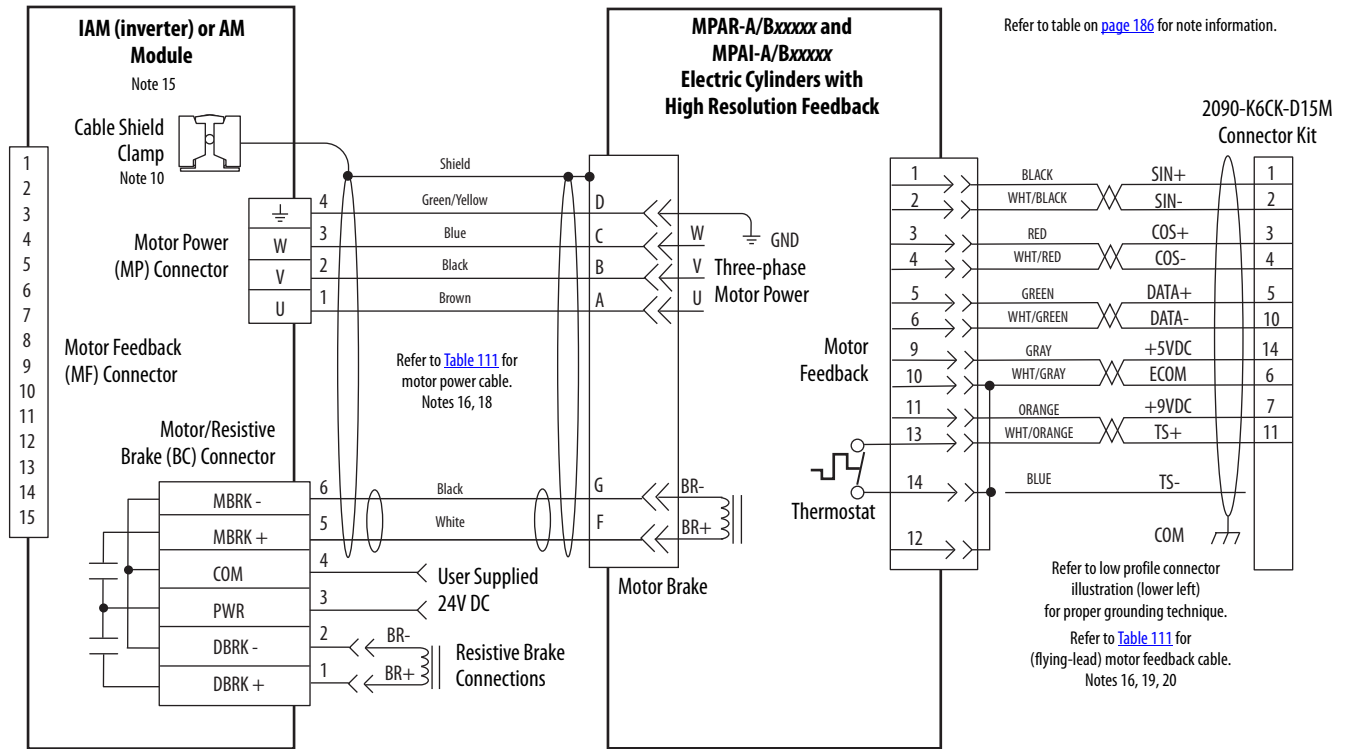

Figure 107 - AM Module with MP-Series Electric Cylinders



Grounding Technique for Feedback Cable Shield

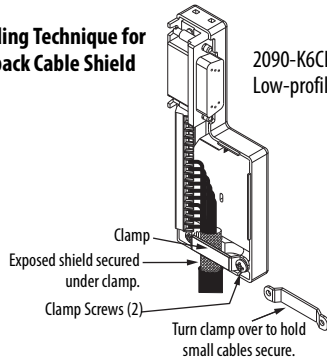
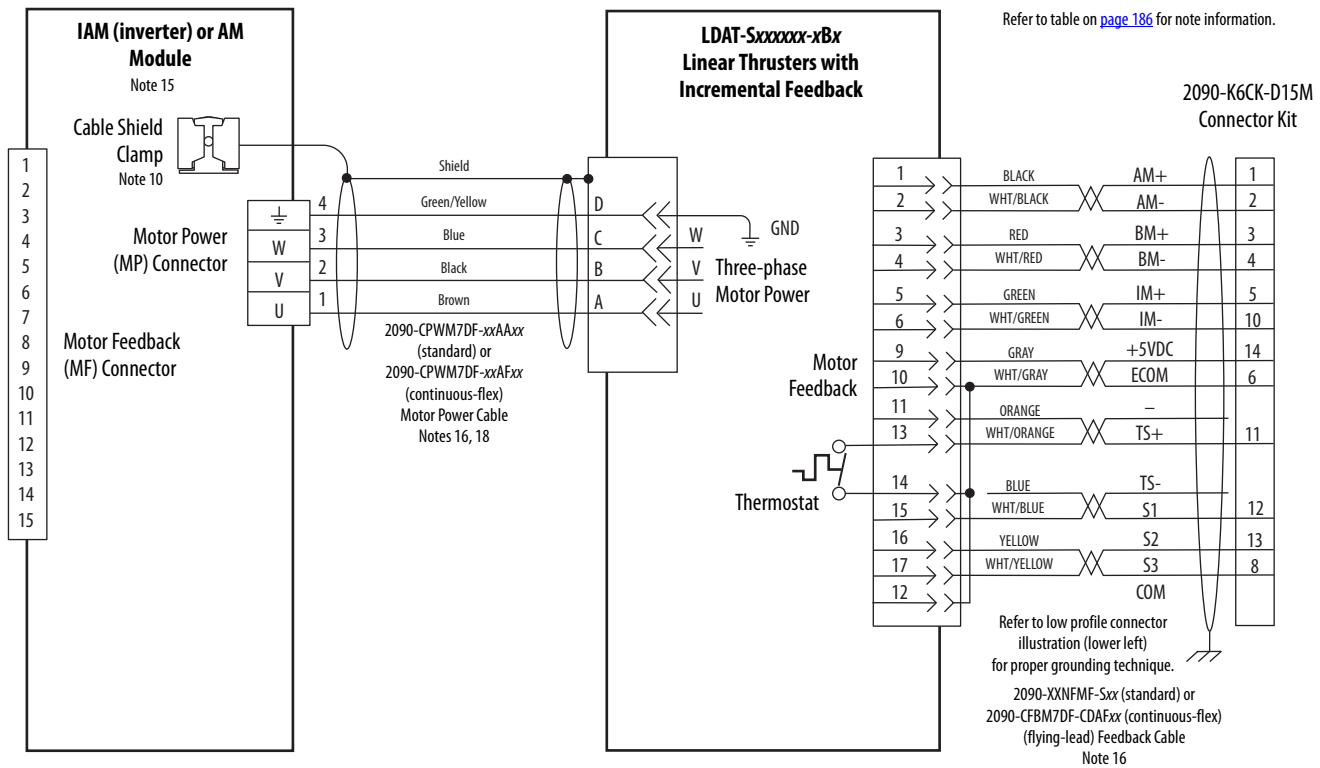

Table 111 - MP-Series Electric Cylinder Power and Feedback Cables

MP-Series Electric Cylinder Cat. No.	Frame	Power Cable Cat. No.	Feedback Cable Cat. No.
MPAR-A/B1xxx (series A)	32	2090-XXNPMF-16Sxx (standard) or 2090-CPxM4DF-16AFxx (continuous-flex)	2090-XXNFMF-Sxx (standard) or 2090-CFBM4DF-CDAFxx (continuous-flex)
MPAR-A/B2xxx (series A)	40		
MPAR-A/B1xxx (series B)	32		
MPAR-A/B2xxx (series B)	40		
MPAR-A/B3xxx	63		
MPAI-A/B2xxxx	64	2090-CPxM7DF-16AAxx (standard) or 2090-CPxM7DF-16AFxx (continuous-flex)	2090-CFBM7DF-CEAAxx (standard) or 2090-CFBM7DF-CEAFxx (continuous-flex)
MPAI-A/B3xxxx	83		
MPAI-A/B4xxxx	110		
MPAI-B5xxxx	144		
MPAI-A5xxxx	144	2090-CPxM7DF-14AAxx (standard) or 2090-CPxM7DF-14AFxx (continuous-flex)	2090-CFBM7DF-CEAAxx (standard) or 2090-CFBM7DF-CEAFxx (continuous-flex)

Figure 108 - AM Module with LDAT-Series Linear Thrusters



Grounding Technique for Feedback Cable Shield

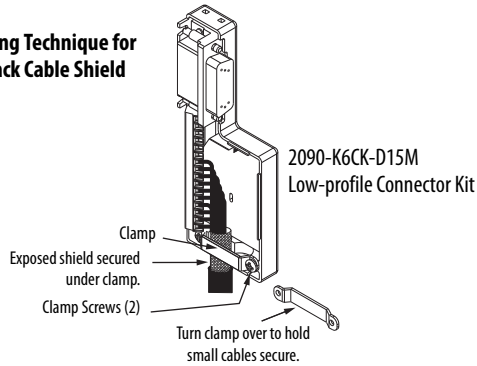

Refer to Low Profile Connector Kit Installation Instructions, publication [2094-IN007](#), for connector kit specifications.

Figure 109 - AM Module with LDC-Series or LDL-Series Linear Motors (cable connectors)

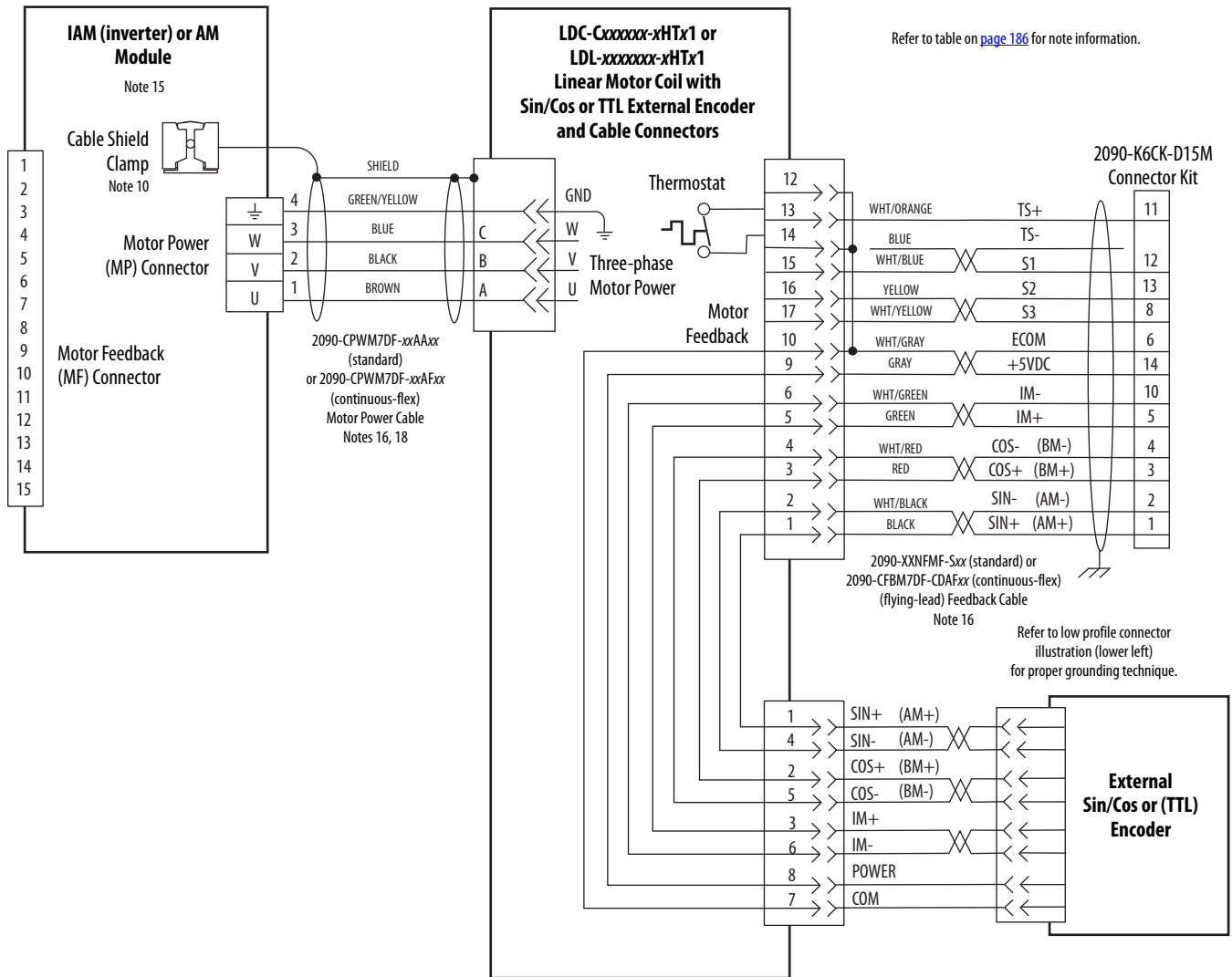

Grounding Technique for Feedback Cable Shield

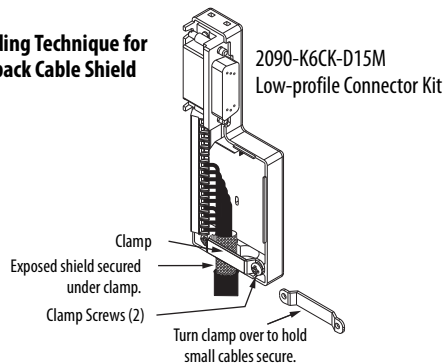

Refer to Low Profile Connector Kit Installation Instructions, publication [2094-IN007](#), for connector kit specifications.

Figure 110 - AM Module with LDC-Series or LDL-Series Linear Motors (flying-lead cables)

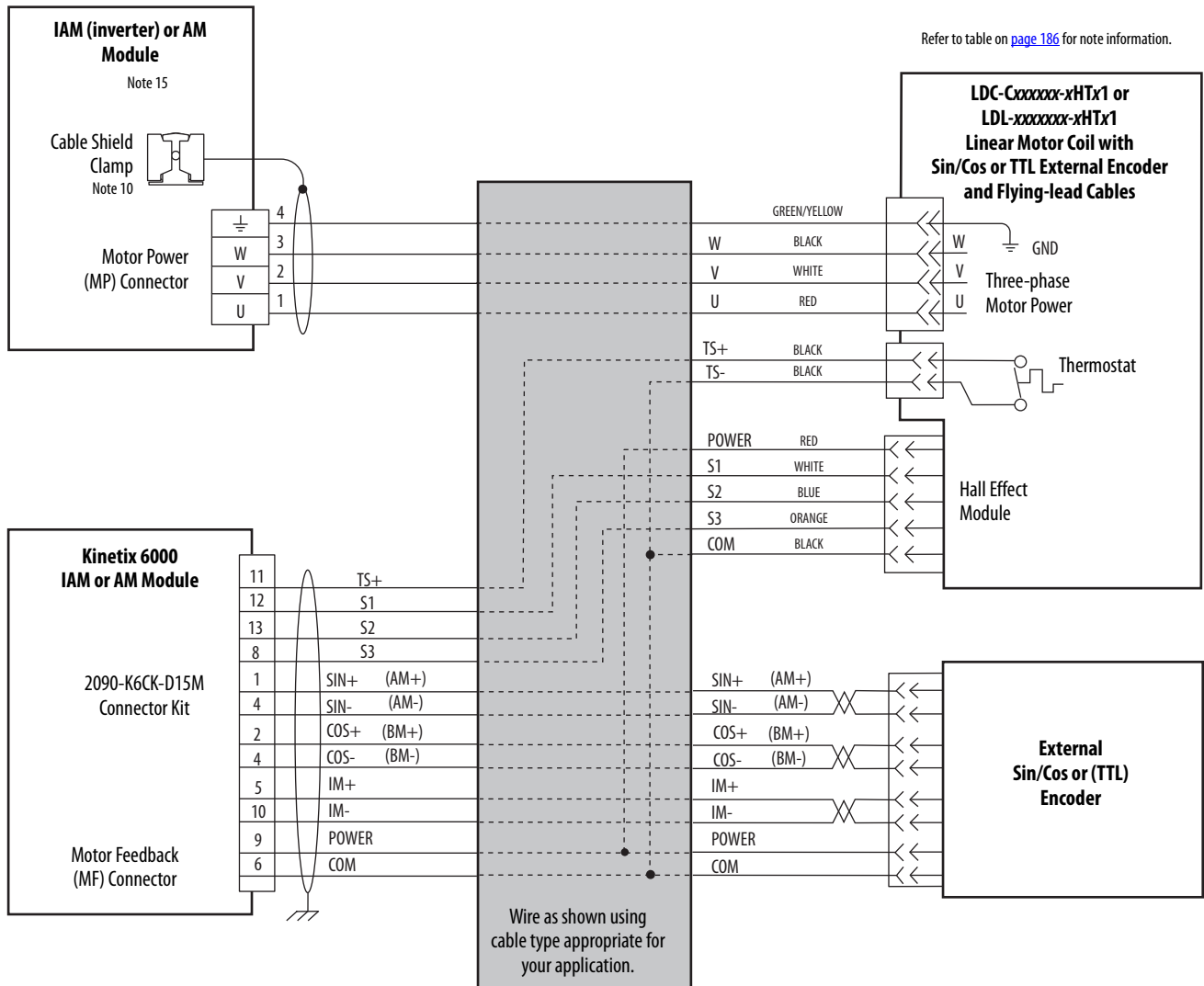

Grounding Technique for Feedback Cable Shield

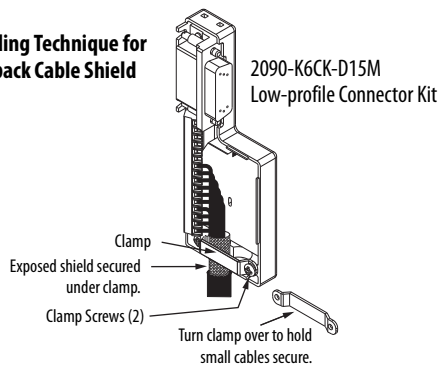

Refer to Low Profile Connector Kit Installation Instructions, publication [2094-IN007](#), for connector kit specifications.

Kinetix 6000M Integrated Drive-Motor Wiring Example

This example applies to Kinetix 6000 drives with Kinetix 6000M IDM systems.

Figure 111 - IPIM Module with IDM Unit

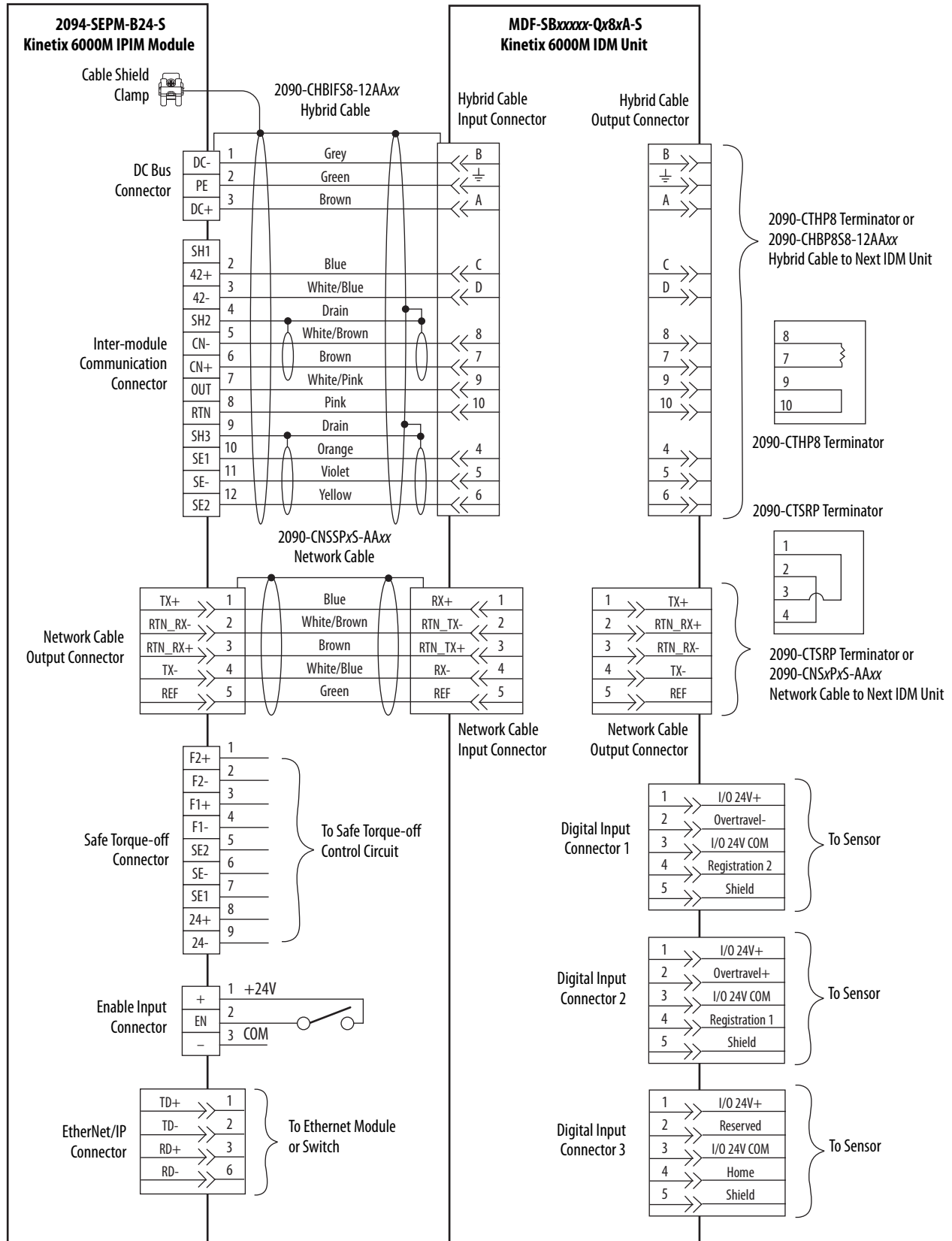

Controlling a Brake Example

The relay output of the Kinetix 6000 (MBRK± BC-5 and BC-6) is suitable for directly controlling a motor brake, subject to the relay voltage limit of 30V DC, and the relay current limit as shown below.

Table 112 - Brake Relay Current Limit

Kinetix 6000 IAM/AM Module	Brake Current Value, max		
	Series A	Series B	Series C
2094-AC05-Mxx-x, 2094-AC09-M02-x, 2094-AMP5-x, 2094-AM01-x, 2094-AM02-x	1.0 A	N/A	3.0 A
2094-BC01-Mxx-x, 2094-BC02-M02-x, 2094-BMP5-x, 2094-BM01-x, 2094-BM02-x		3.0 A	
2094-AC16-M03-x, 2094-AC32-M05-x, 2094-AM03-x, 2094-AM05-x	1.3 A	N/A	
2094-BC04-M03-x, 2094-BC07-M05-x, 2094-BM03-x, 2094-BM05-x	3.0 A	3.0 A	

Table 113 - Coil Currents Rated at <1.0 A

Compatible Brake Motors/Actuators ⁽¹⁾	Coil Current
MPL-x1510, MPL-x1520, MPL-x1530	0.43...0.53 A
MPL-x210, MPL-x220, MPL-x230	0.46...0.56 A
MPL/MPF-x310, MPL/MPF-x320, MPL/MPF-x330	0.45...0.55 A
MPS-x330, MPM-x115, MDF-SB1003	
MPL-x420, MPL-x430, MPL-x4520, MPL-x4530, MPL-x4540, MPL-x4560	0.576...0.704 A
MPF-x430, MPF-x4530, MPF-x4540	
MPS-x4540, MPM-x130, MDF-SB1153, MDF-SB1304	

Compatible Brake Motors	Coil Current
TLY-A110T-H, TLY-A120T-H, and TLY-A130T-H	0.18...0.22 A
TLY-A220T-H and TLY-A230T-H	0.333...0.407 A
TLY-A2530P-H, TLY-A2540P-H, and TLY-A310M-H	0.351...0.429 A
1326AB-B4xxx	0.88 A
F-4030, F-4050, and F-4075	0.69 A

Table 114 - Coil Currents Rated at >1.0 A and ≤ 1.3 A

Compatible Brake Motors ⁽¹⁾	Coil Current
MPL-xB520, MPL-xB540, MPL-x560, MPL-x580	1.05...1.28 A
MPF-x540, MPS-B560, MPM-x165	

Compatible Brake Motors	Coil Current
F-6100, F-6200, and F-6300	1.30 A
1326AB-B5xxx, and 1326AB-B7xxx	1.20 A

(1) Use of the variable *x* indicates this specification applies to 230V and 460V motors.

Table 115 - Coil Currents Rated at >1.3 A and ≤ 3.0 A

Compatible Brake Motors	Coil Current
MPL-B640, MPL-B660, MPL-B680	1.91...2.19 A
MPL-B860, MPL-B880	2.05...2.50 A
MPM-x215	1.84...2.25 A
MPL-B960, MPL-B980	N/A

IMPORTANT Because the coil current for MPL-B960 and MPL-B980 motors is rated 3.85...4.70 A, an external relay must be used.

System Block Diagrams

This section provides block diagrams of the Kinetix 6000 drive modules. For block diagrams of the LIM module and RBM module, refer to Additional Resources on [page 12](#) for the documentation available for those products.

Figure 112 - IAM/AM Module (inverter) Block Diagram

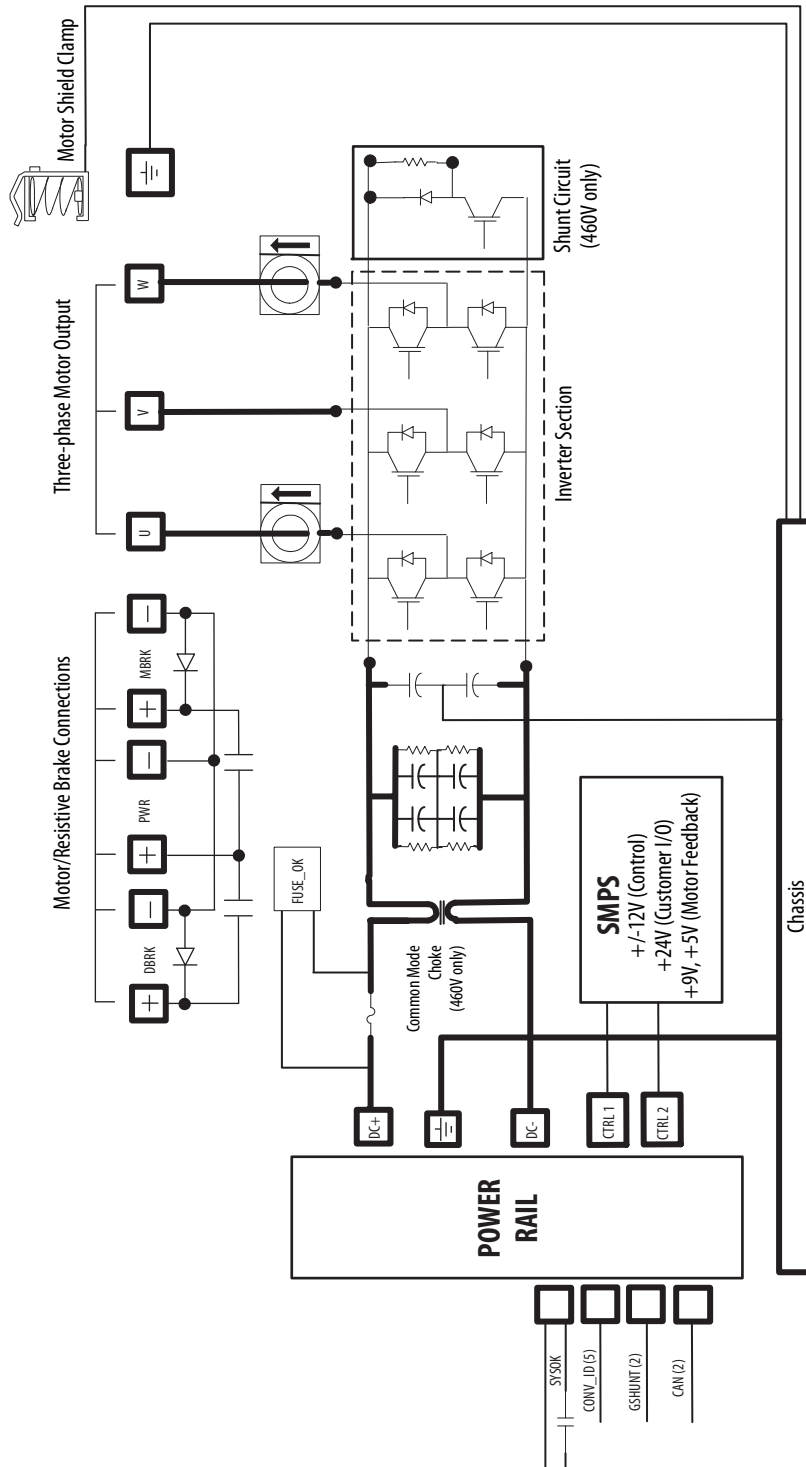
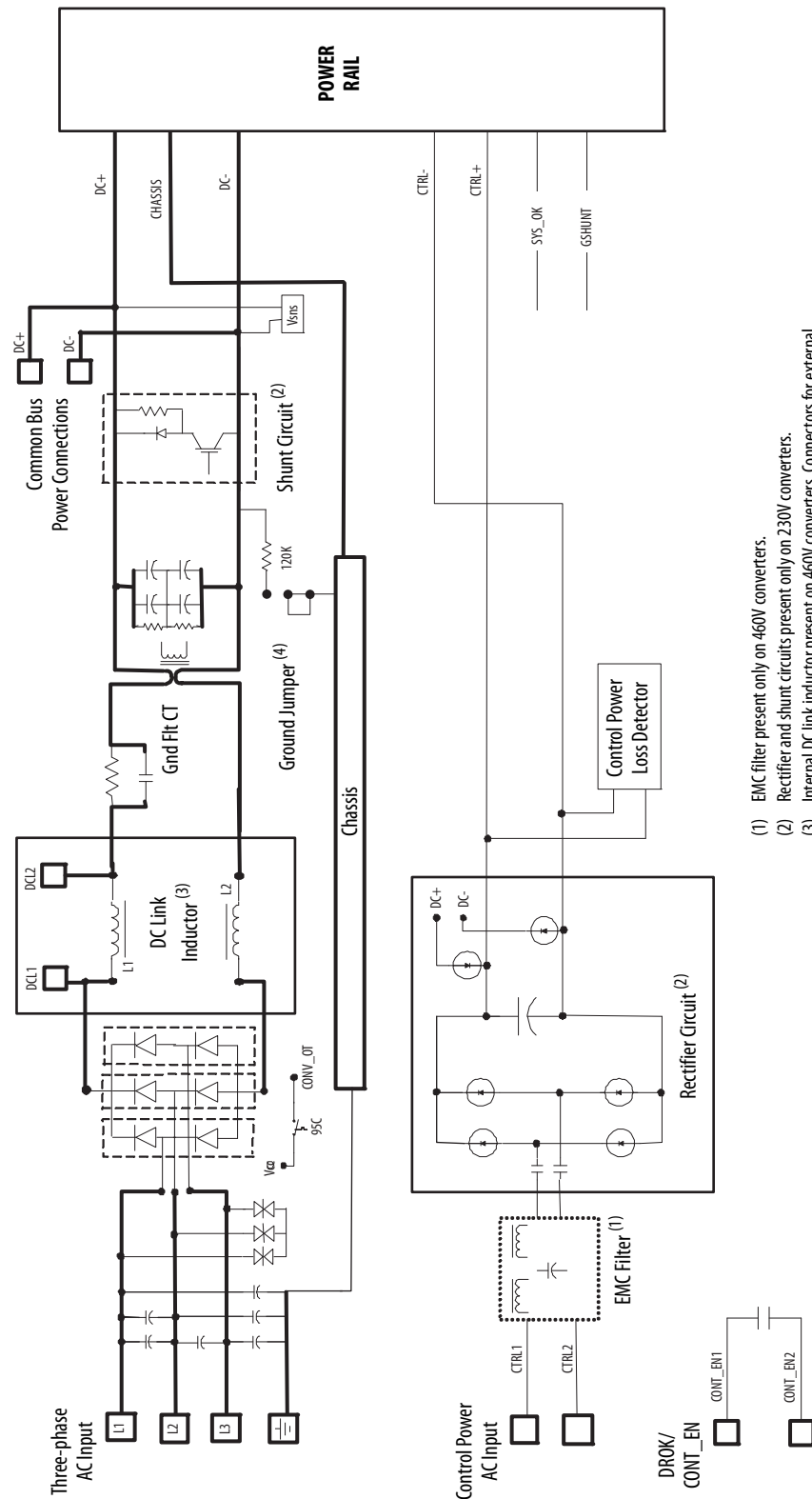
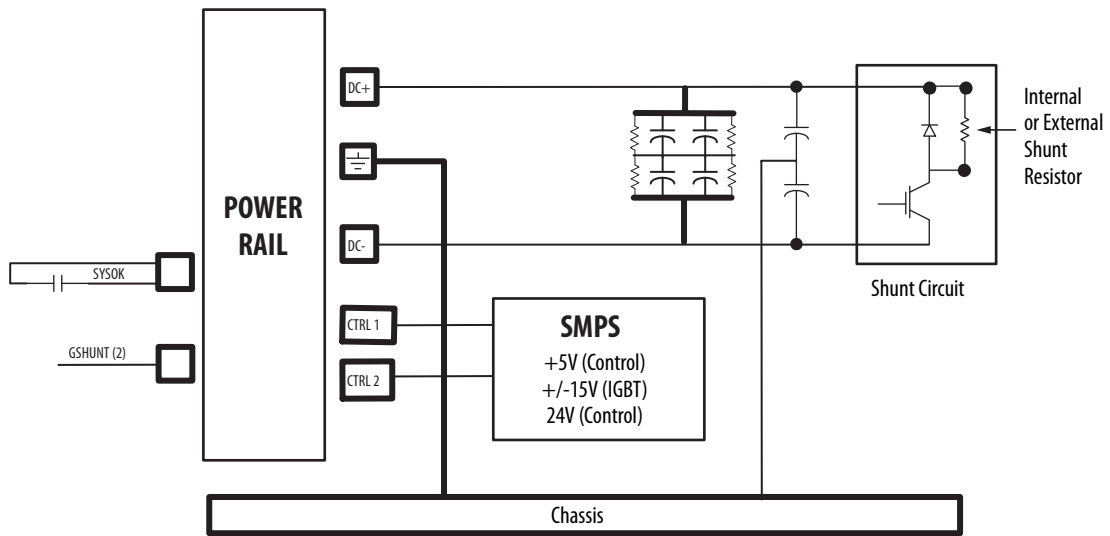

Figure 113 - IAM Module (converter) Block Diagram



- (1) EMC filter present only on 460V converters.
- (2) Rectifier and shunt circuits present only on 230V converters.
- (3) Internal DC link inductor present on 460V converters. Connectors for external DC link inductor present on 230V converters.
- (4) Ground jumper shown in default configuration (grounded facility power).

Figure 114 - Shunt Module Block Diagram



Upgrading the Drive Firmware

This appendix provides procedures for upgrading firmware by using either ControlFLASH software.

Topic	Page
Upgrade Kinetix 6000M System Firmware	215
Upgrade Drive Firmware with ControlFLASH Software	216

Upgrade Kinetix 6000M System Firmware

Upgrading firmware for the Kinetix 6000M integrated drive-motor (IDM) system is done by using ControlFLASH software. The procedure for upgrading the IDM units uses the sercos interface, similar to the axis modules. However, upgrading firmware on the IPIM module is accomplished over the EtherNet/IP network.

IMPORTANT DriveExplorer software does not apply to Kinetix 6000M firmware upgrades.

For the firmware upgrade procedure specific to the IDM system, refer to the Kinetix 6000M Integrated Drive-Motor System User Manual, publication [2094-UM003](#).

Upgrade Drive Firmware with ControlFLASH Software

Upgrading axis module firmware by using ControlFLASH software involves configuring your controller communication, selecting the drive to upgrade, and upgrading the firmware.

Before You Begin

You need the following software and information before you begin.

Description	Cat. No.	Firmware Revision or Software Version
RSLogix 5000 software or the Logix Designer application	RSLogix 5000 software	15.x or later
	Logix Designer application	21.x or later
ControlLogix sercos module	1756-MxxSE	15.32 or later
	1756-L60M03SE	15.4 or later
CompactLogix sercos module	1768-M04SE	15.35 or later
SoftLogix sercos PCI card	1784-PM16SE	15.33 or later
RSLin [®] software		2.50 or later
ControlFLASH software kit ⁽¹⁾		4.00.09 or later

Catalog number of the targeted IAM/AM module you want to upgrade

Network path to the targeted IAM/AM module.

- (1) Download the ControlFLASH kit from <http://support.rockwellautomation.com/controlflash>. Contact Rockwell Automation Technical Support at (440) 646-5800 for assistance. For more ControlFLASH information (not drive specific), refer to the ControlFLASH Firmware Upgrade Kit User Manual, publication [1756-UM105](#).

IMPORTANT

Control power must be present at CPD-1 and CPD-2 prior to upgrading your target drive.

The seven-segment status indicator on the target IAM (inverter) module or AM module must be displaying a fixed 2, 3, or 4 before beginning this procedure.



ATTENTION: To avoid personal injury or damage to equipment during the firmware upgrade due to unpredictable motor activity, do not apply three-phase AC or common-bus DC input power to the drive.

Configure Logix5000 Communication

This procedure assumes that your communication method to the Logix5000 controller is using the Ethernet protocol. It is also assumed that your Logix5000 Ethernet module has already been configured.

For more information, refer to the ControlLogix System User Manual, publication [1756-UM001](#).

Follow these steps to configure Logix5000 communication.

1. Open your RSLinx Classic software.
2. From the Communications pull-down menu, choose Configure Drivers.

The Configure Drivers dialog box opens.

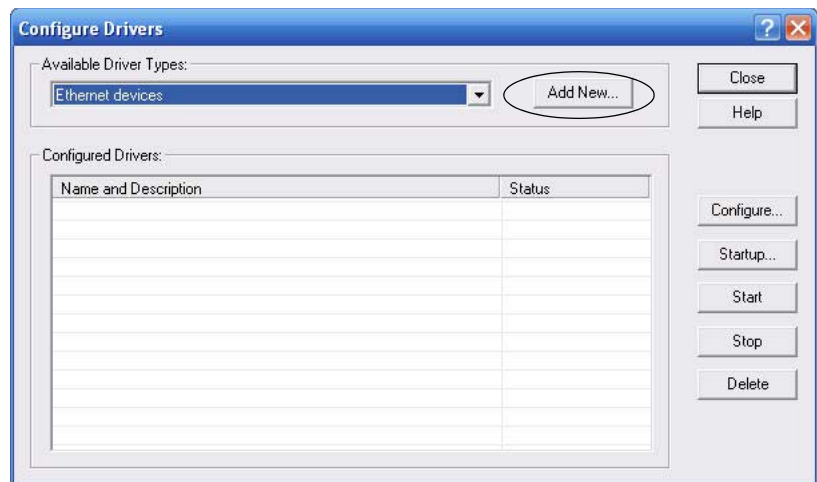

3. From the Available Drive Types pull-down menu, choose Ethernet devices.
4. Click Add New.

The Add New RSLinx Classic Driver dialog box opens.

5. Type the new driver name.



6. Click OK.

The Configure driver dialog box opens.

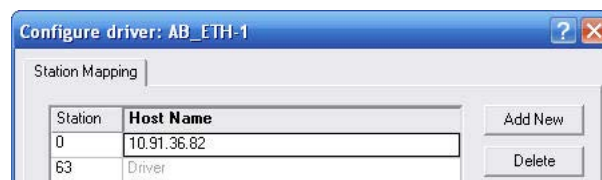

7. Type the IP address of your Logix5000 Ethernet module.
The IP address shown is an example. Yours will be different.
8. Click OK.

The new Ethernet driver appears under Configured Drivers.

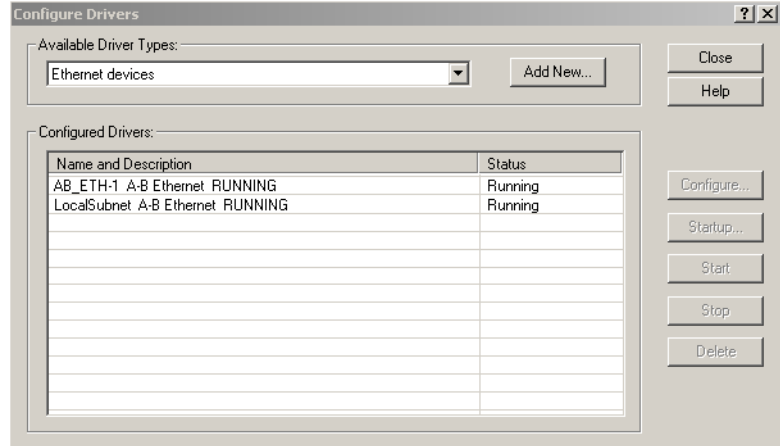

9. Click Close.
10. Minimize the RSLinx application dialog box.

Upgrade Firmware

Follow these steps to select the drive module to upgrade.

1. Open your ControlFLASH software.

You can access the ControlFLASH software by either of these methods:

- From the Tools menu in the Logix Designer application, choose ControlFLASH.
- Choose Start>Programs>FLASH Programming Tools>ControlFLASH.

The Welcome to ControlFLASH dialog box opens.

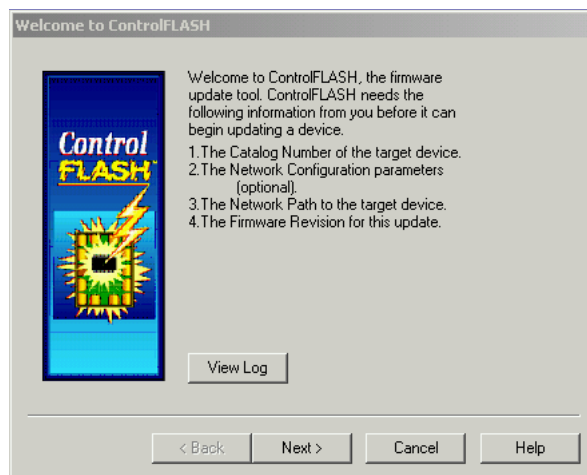

2. Click Next.

The Catalog Number dialog box opens.

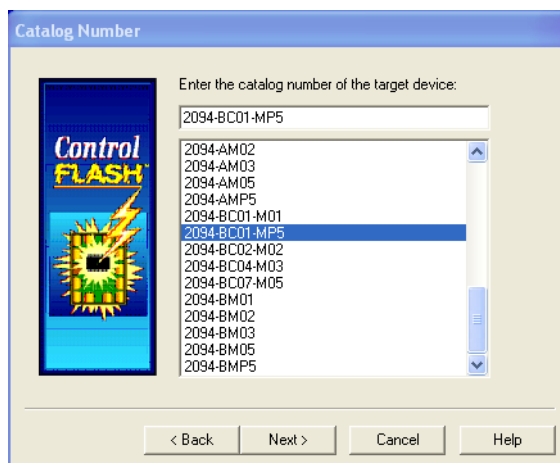

3. Select your drive module.

In this example, the 2094-BC01-MP5 IAM module is selected.

4. Click Next.

The Select Device to Update dialog box opens.

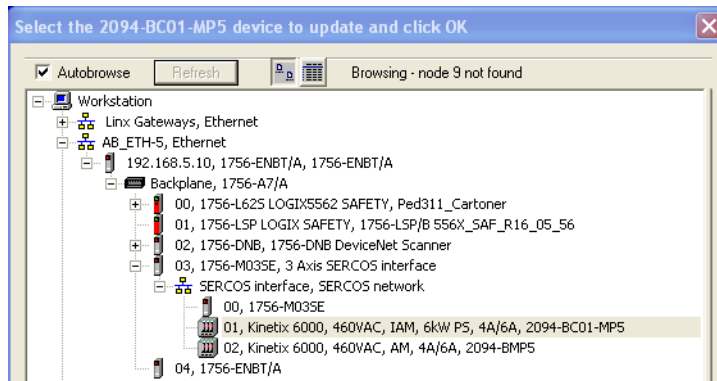

5. Expand your Ethernet node, Logix5000 backplane, and EtherNet/IP network module.
6. Select the servo drive to upgrade.
7. Click OK.

The Firmware Revision dialog box opens.

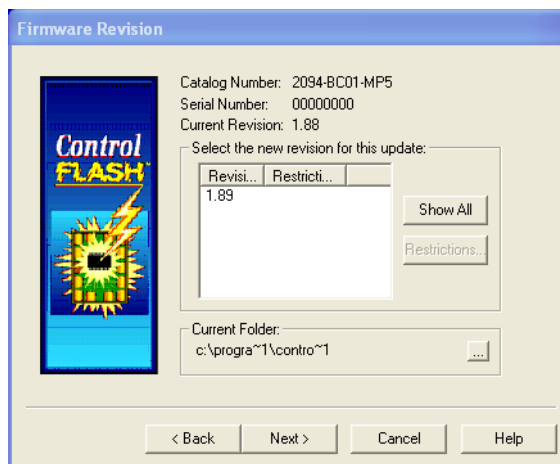

8. Select the firmware revision to upgrade.
9. Click Next.

The Summary dialog box opens.

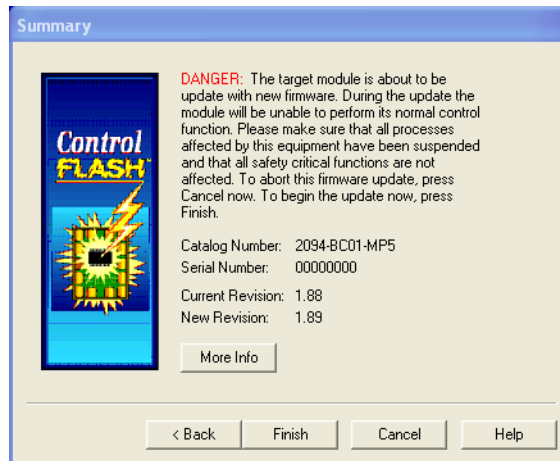

- 10. Confirm the drive catalog number and firmware revision.
- 11. Click Finish.

This ControlFLASH warning dialog box opens.

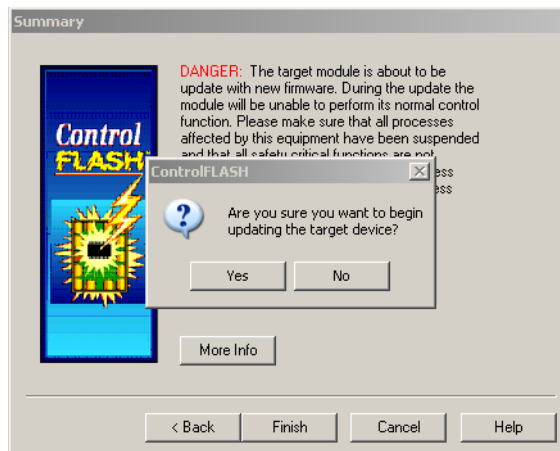

- 12. Click Yes (only if you are ready).

This ControlFLASH warning dialog box opens.

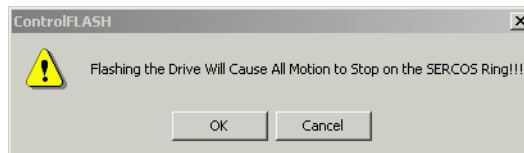

- 13. Acknowledge the warning and click OK.

The Progress dialog box opens and upgrading begins.

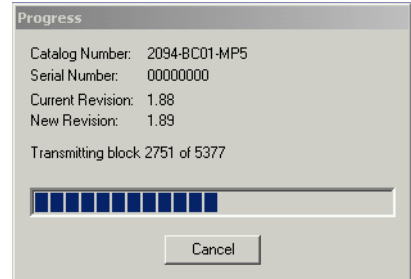

The drive module seven-segment status indicator changes from the fixed 2, 3, or 4 to F, which indicates that upgrading is in progress.

After the upgrade information is sent to the drive, the drive resets and performs diagnostic checking.

14. Wait for the Progress dialog box to time out.

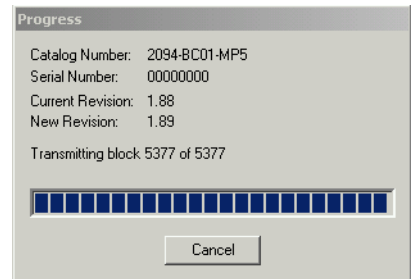

15. The Update Status dialog box opens and indicates success or failure as described below.

Upgrading Status	If
Success	<ol style="list-style-type: none"> 1. Update complete appears in a GREEN Status dialog box. 2. Go to step 16.
Failure	<ol style="list-style-type: none"> 1. Update failure appears in a RED Status dialog box. 2. Refer to ControlFLASH Firmware Upgrade Kit Quick Start, publication 1756-QS105, for troubleshooting information.

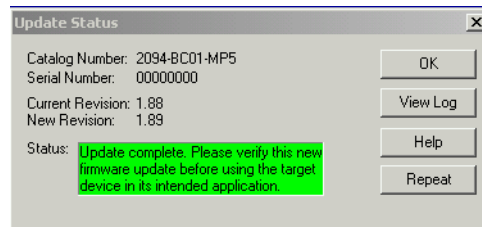

16. Click OK.

Verify the Firmware Upgrade

Follow these steps to verify your firmware upgrade was successful.

TIP Verifying the firmware upgrade is optional.

1. Open your RSLinx software.
2. From the Communications pull-down menu, choose RSWho.

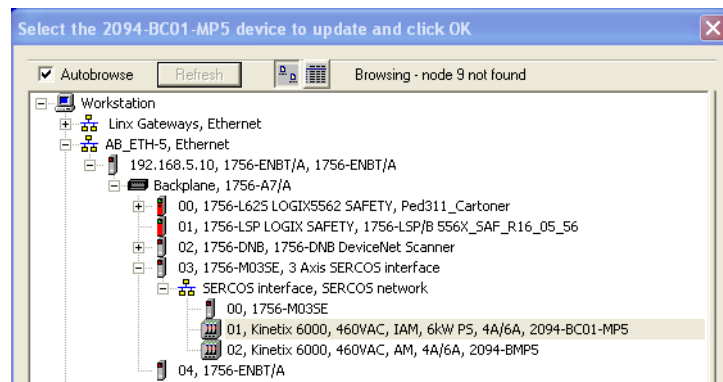

3. Expand your Ethernet node, Logix5000 backplane, and EtherNet/IP network module.
4. Right-click the drive module and choose Device Properties.

The Device Properties dialog box opens.

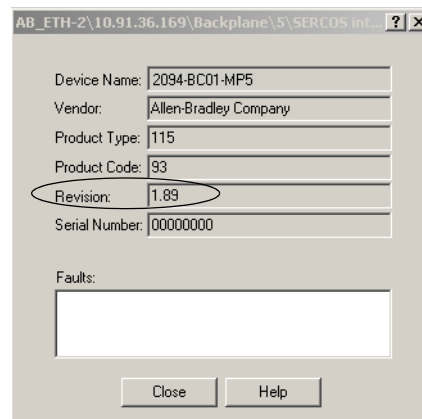

5. Verify the new firmware revision level.
6. Click Close.

Notes:

DC Common Bus Applications

This appendix provides integration procedures specific to Kinetix 6000 multi-axis drive systems configured for DC common bus. The procedure involves calculating capacitance values and setting the Additional Bus Capacitance parameter by using DriveExplorer software.

Topic	Page
Before You Begin	225
Calculate Total Bus Capacitance	226
Calculate Additional Bus Capacitance	227
Bulletin 2094 Drive Capacitance Values	227
Common Bus Capacitance Example	228
Set the Additional Bus Capacitance Parameter	229

To set the Additional Bus Capacitance parameter by using the Logix Designer application, refer to [Appendix E](#) beginning on [page 249](#).

Calculating capacitance, as it applies to the Bulletin 2094 shunt module and Kinetix 6000M IPIM module, is also included in this appendix.

Before You Begin

These procedures assume you have mounted and wired your Kinetix 6000 DC common-bus system.

Before you set the Additional Bus Capacitance (Add Bus Cap) parameter in DriveExplorer software or the Logix Designer application, you need to calculate these values:

- Total bus capacitance
- Additional bus capacitance

Calculate Total Bus Capacitance

Total bus capacitance is the sum of all capacitance values for your Bulletin 2094 common-bus modules. Specifically, this includes the capacitance values for each of these modules:

- Leader IAM (converter and inverter) module
- Each AM and shunt module (if present) on the leader IAM power rail
- Each IPIM module (if present) on the leader IAM power rail
- Each follower IAM (converter and inverter) module
- Each AM module on the follower IAM power rail
- Each IPIM module (if present) on the follower IAM power rail

Refer to Bulletin 2094 Drive Capacitance Values on [page 227](#) for IAM, AM, IPIM, and shunt module capacitance values.

IMPORTANT If total bus capacitance of your system exceeds the leader IAM module pre-charge rating and input power is applied, the IAM module seven-segment status indicator displays error code E90 (pre-charge timeout fault).
To correct this condition, you must replace the leader IAM module with a larger module or decrease the total bus capacitance by removing AM modules or IPIM modules.

Table 116 - Maximum IAM Module Bus Capacitance

Leader IAM (200V-class) Module	Bus Capacitance, max μF	Leader IAM (400V-class) Modules	Bus Capacitance, max μF
2094-AC05-MP5-x	7145	2094-BC01-MP5-x	4585
2094-AC05-M01-x		2094-BC01-M01-x	
2094-AC09-M02-x	15,295	2094-BC02-M02-x	8955
2094-AC16-M03-x	34,400	2094-BC04-M03-x	8955
2094-AC32-M05-x	62,825	2094-BC07-M05-x	17,915

IMPORTANT If your total bus capacitance value exceeds the value in the table above, you must increase the size of the leader IAM module or decrease the total bus capacitance by removing other modules on the power rail.

Calculate Additional Bus Capacitance

Additional bus capacitance is the sum of all follower IAM, AM, and IPIM module capacitance values for your Bulletin 2094 common-bus modules. Specifically, this includes the capacitance values for each of these modules:

- Each follower IAM (converter and inverter) module
- Each AM module on the follower IAM module power rail
- Each IPIM module on the follower IAM module power rail

Enter the additional bus capacitance value in Set the Additional Bus Capacitance Parameter beginning on [page 230](#).

Bulletin 2094 Drive Capacitance Values

Use these tables when calculating total bus capacitance and additional bus capacitance for your Bulletin 2094 common-bus application.

Table 117 - IAM/AM (200V-class) Modules

IAM Converter (200V-class)	Capacitance μF	AM Inverter (200V-class)	Capacitance μF
2094-AC05-MP5-x	270	2094-AMP5-x	390
2094-AC05-M01-x		2094-AM01-x	660
2094-AC09-M02-x	540	2094-AM02-x	780
2094-AC16-M03-x	1320	2094-AM03-x	1320
2094-AC32-M05-x	1980	2094-AM05-x	2640

Table 118 - IAM/AM (400V-class) Modules

IAM Converter (400V-class)	Capacitance μF	AM Inverter (400V-class)	Capacitance μF
2094-BC01-MP5-x	110	2094-BMP5-x	75
2094-BC01-M01-x		2094-BM01-x	150
2094-BC02-M02-x	220	2094-BM02-x	270
2094-BC04-M03-x	940	2094-BM03-x	840
2094-BC07-M05-x	1410	2094-BM05-x	1175

Table 119 - Shunt Module (200/400V-class)

Shunt Module (200/400V-class)	Capacitance μF
2094-BSP2	470

Table 120 - IPIM Module (400V-class)

IPIM Module (400V-class)	Capacitance μF
2094-SEPM-B24-S	840

Common Bus Capacitance Example

In this example, the sum of the leader IAM power rail modules capacitance (6530 μF) and the follower IAM power rail modules capacitance (5280 μF) equals 11,810 μF total bus capacitance.

The sum of the follower IAM module power rail equals 5280 μF additional bus capacitance.

Figure 115 - Calculating Common Bus Capacitance

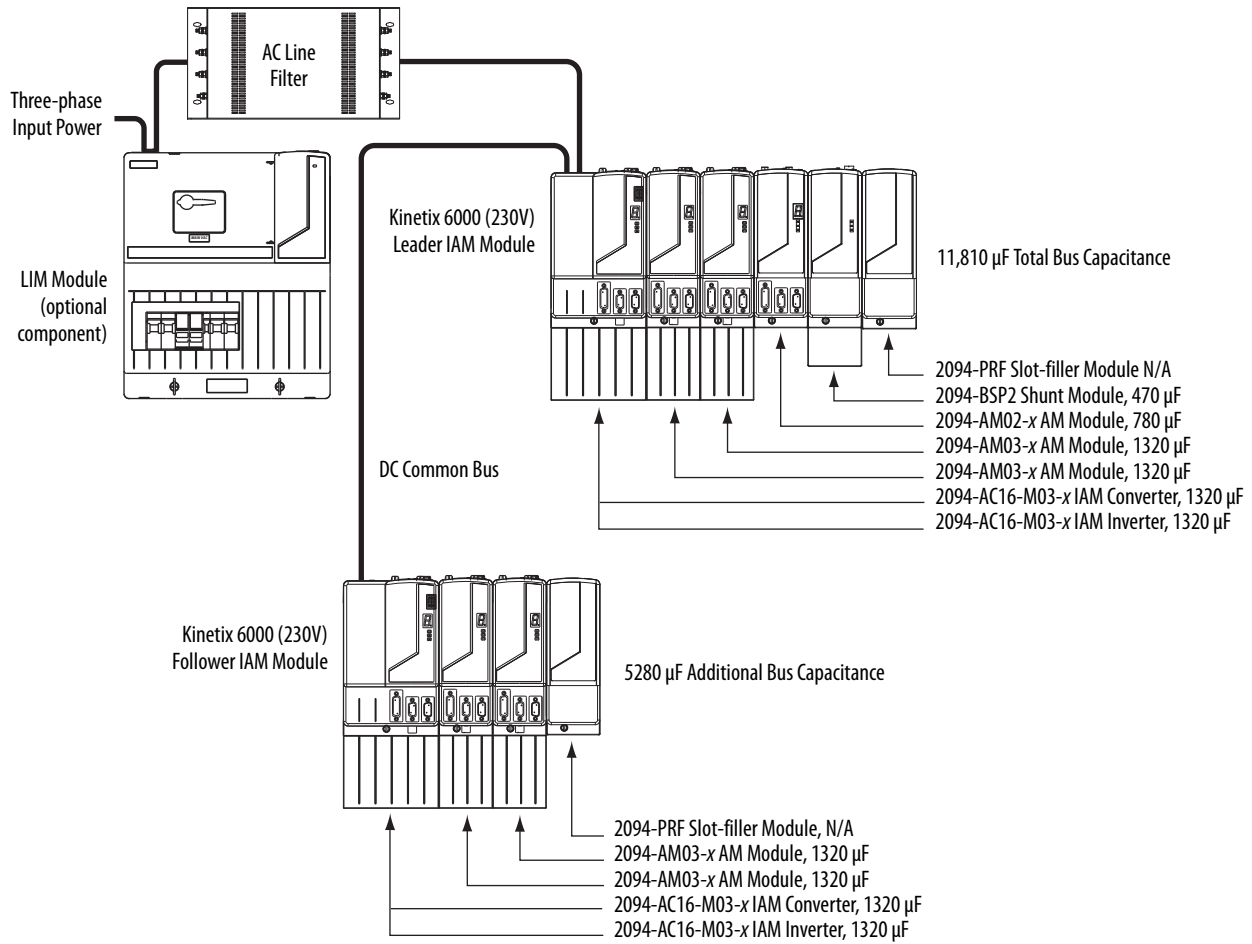

Set the Additional Bus Capacitance Parameter

In this section you set the Add Bus Cap parameter by using DriveExplorer software.

TIP You can also set the Add Bus Cap parameter by changing IDN parameter values. Refer to [Appendix E](#) on [page 249](#) for more information.

TIP You can use this procedure to change other parameters too, the Analog Output parameters, for example.

The following hardware and software tools are required to provide the necessary communication link between your personal computer and the Kinetix 6000 drive system running DriveExplorer software.

Table 121 - Kinetix 6000 System Requirements

Description	Cat. No.	Version
DriveExplorer software ⁽¹⁾ ⁽²⁾	9306-4EXP02ENE	2.01 or later
Serial to SCANport adapter ⁽²⁾ ⁽³⁾	1203-SSS (Series B)	3.004 or later
Studio 5000 Logix Designer application	9324-RLD300xxE	21.0 or later
RSLogix 5000 software		15.0 or later

(1) Refer to DriveExplorer Getting Results Manual, publication [9306-GR001](#), for instructions.

(2) Additional information regarding these communication and software tools is available at <http://www.ab.com/support/abdrives>.

(3) Refer to 1203-SSS (series B) FRN 3.xxx User Manual, publication [20COMM-UM001](#), for instructions.



ATTENTION: To avoid personal injury or equipment damage, at least one end of a sercos fiber-optic cable must be disconnected from the drive. This makes sure that motion does not occur while changes are being made to the Add Bus Cap parameter.

Remove Sercos Communication

Follow these steps to remove (break) sercos communication.

1. Remove three-phase and control power from the Kinetix 6000 drive system.
2. Remove one of the sercos fiber-optic cables.

Fiber-optic cable connections (Tx and Rx) are on the top of each IAM and AM module.

3. Re-apply three-phase and control power.

Set the Additional Bus Capacitance Parameter

Follow these steps to set the Additional Bus Capacitance parameter.

1. Start your DriveExplorer software.
2. From the Explore menu, choose Connect>Local or press CTRL+L.
DriveExplorer software will read your system.
3. Observe the Linear List of parameters as grouped by Node, Port, and Axis hierarchy as shown below.

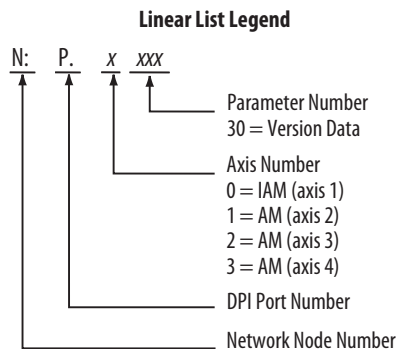

4. Choose Devices>Node>Product and navigate to the parameter *x:x:x599* as shown below.

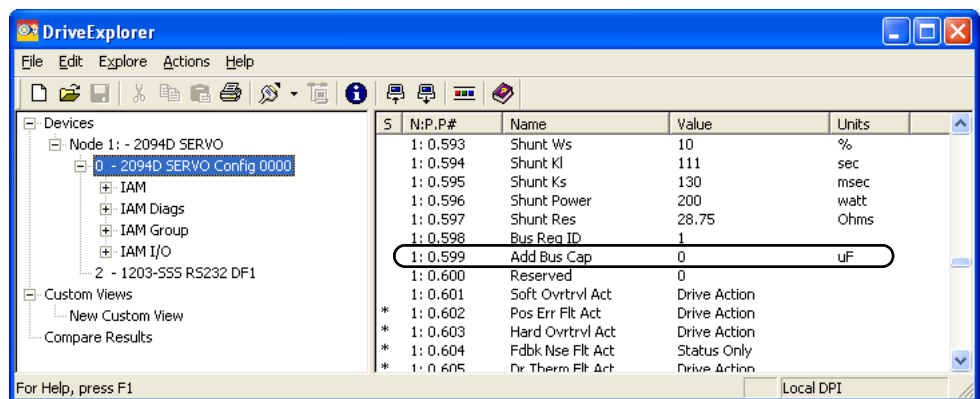

5. Double-click the *x:x:x599* Add Bus Cap parameter.

The command dialog box for parameter $x599$ - Add Bus Cap opens.

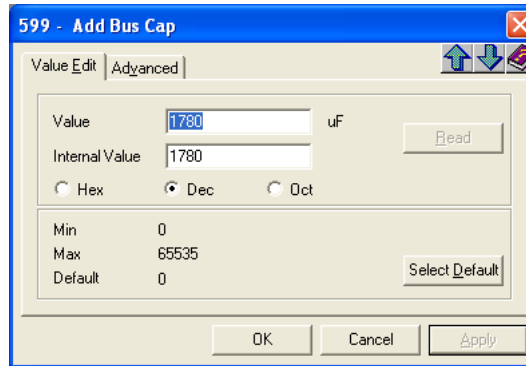

6. Click the Value Edit tab and enter the Add Bus Cap Value (μF).
7. Click OK.

The Add Bus Cap value is changed, but not saved in nonvolatile memory.

Save the Add Bus Cap Parameter to Nonvolatile Memory

Follow these steps to save the Add Bus Cap parameter to nonvolatile memory.

1. From the Actions menu, choose Nonvolatile Memory.

This message dialog box opens.

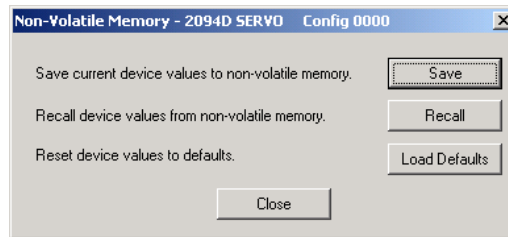

2. Click Save.

The changes are saved to nonvolatile memory and this cautionary message dialog box opens.

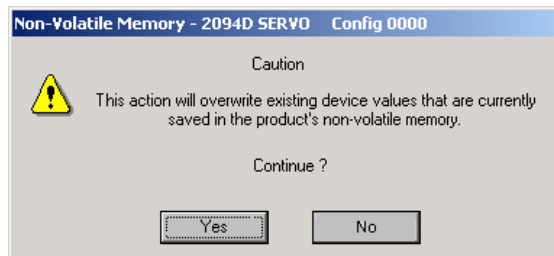

3. Click Yes.

The save to nonvolatile memory is complete and this confirmation message dialog box opens.

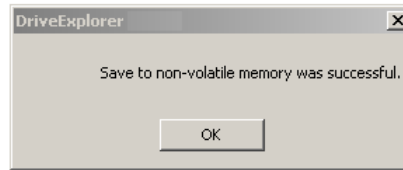

4. Click OK.
5. Close the DriveExplorer software.

Verify the Parameter Changes

Follow these steps to verify your parameter change was successful.

TIP Verifying the parameter change is optional.

1. Open your DriveExplorer software.
2. Cycle the drive control power.
3. Reconnect the drive to your DriveExplorer software and read the Add Bus Cap value just like you did in Set the Additional Bus Capacitance Parameter on [page 230](#).

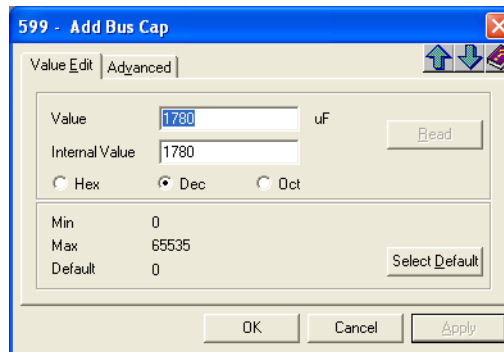

4. Verify the new parameter value.
In this example, the new value is 1780 μ F.
5. Close the DriveExplorer software.

Reconnect Sercos Communication

Follow these steps to reconnect sercos communication.

1. Remove three-phase and control power from the Kinetix 6000 drive system.
2. Replace the sercos fiber-optic cable removed earlier.
Fiber-optic cable connections (Tx and Rx) are on the top of each IAM and AM module.
3. Re-apply three-phase and control power.

Notes:

Configure the Load Observer Feature

The load observer feature is a control loop inside the drive that estimates the mechanical load on the motor and compensates for it, thereby forcing the motor to behave as if it is unloaded and relatively easy to control. As a result, load observer automatically compensates for disturbances and load dynamics, such as sudden inertia/torque changes, compliance, backlash, and resonances.

Topic	Page
Benefits	235
How it Works	235
Configuration	236
Setting Gains with Sercos IDN Write Messages	246
Compensate for High Frequency Resonances	247

Benefits

You can use load observer with out-of-box controller gains, where the load is unknown and thus the Load Inertia Ratio = 0, or with auto-tuned controller gains, where the Load Inertia Ratio is known or calculated by performing an auto-tune procedure.

When used with out-of-box controller gains, load observer does the following.

- Provides relatively high-performance motion control without tuning
- Automatically compensates for load resonances and machine wear over time

When used with auto-tuned controller gains, load observer does the following.

- Increases controller bandwidth
- Reduces tracking errors, so line speeds can be increased
- Provides tighter control of moving parts, reducing wear and saving material costs

How it Works

Load observer acts on the acceleration signal within the control loops and monitors the Acceleration Reference and the Actual Position Feedback. Load observer models an ideal unloaded motor and generates a load Torque Estimate, in torque units, that represents any deviation in response of the actual motor and mechanics from the ideal model. This deviation represents the reaction torque placed on the motor shaft by the load mechanics. It is estimated in real time and compensated by closed loop operation.

Figure 116 - Load Observer and Control Loop Signals Relationship Block Diagram

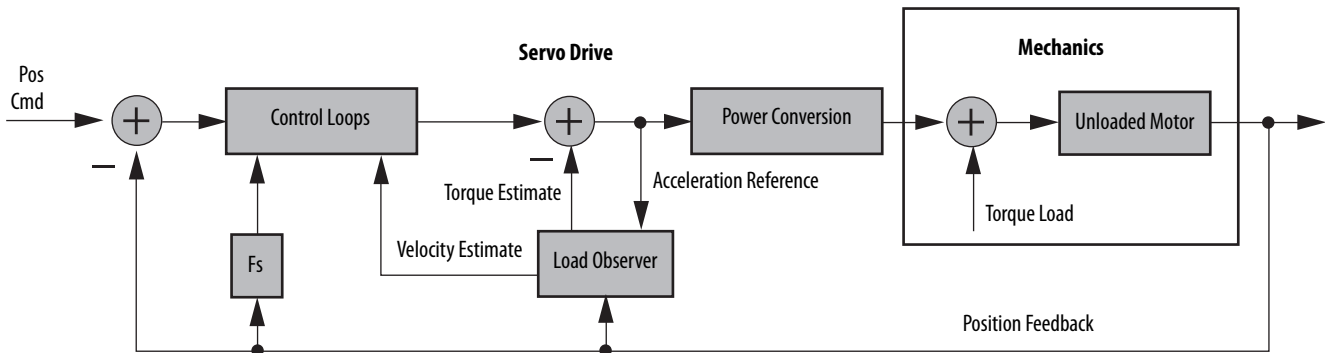

Load observer also generates a Velocity Estimate signal that you can apply to the velocity loop. The Velocity Estimate has less delay than the Velocity Feedback signal derived from the actual feedback device. It also helps to reduce high frequency output noise caused by load observer's aggressive action on the acceleration reference. Together, load observer with the Velocity Estimate setting provides the best overall performance.

Configuration

You can configure the load observer feature in a variety of ways by writing to a set of configuration IDN parameters. The overall behavior of load observer is controlled by Load Observer Configuration (IDN P-431). This parameter is used to select the load observer mode. It can be set to the following values.

Table 122 - Load Observer Modes

Mode	Value	Description
Disabled (default)	0	Load Observer is inactive
Load Observer Only	1	Provides a Torque Estimate only This setting is a filtered acceleration feedback with the addition of integral action below the observer bandwidth that is active in the acceleration forward path. This greatly increases the disturbance rejection properties (stiffness) over the acceleration feedback setting. However, it is also fairly aggressive and the observer bandwidth must be decreased significantly for stable operation.
Load Observer with Velocity Estimate	2	Standard Operation: Provides Torque and Velocity Estimates This setting combines the best of the Load Observer Only and Velocity Estimate Only settings. Separately, load observer removes error, but is too aggressive, and the velocity estimate setting provides a smooth response, but creates error. Together, they remove error and provide a smooth response. Load observer performs well in situations that require adapting to changing inertia and velocity integrator anti-windup.
Velocity Estimate Only	3	Provides a Velocity Estimate only This setting creates a filtered velocity feedback signal that is void of phase lag. Less phase lag (delay around the loop) allows for higher performance. However, the signal is modeled at frequencies above the observer bandwidth, producing error in velocity feedback. This generates a fictitiously lower velocity error since velocity error equals velocity command minus velocity feedback. Nevertheless, the steady state error disappears when used in position mode with either the position integrator or the observer integrator.
Acceleration Feedback	4	Provides acceleration feedback by disconnecting Acceleration Reference to load observer This setting creates a filtered acceleration feedback signal. This setting is fairly aggressive and the observer bandwidth must be decreased significantly for stable operation. The Load Observer Only setting is similar, but without the additional phase lag (delay) created by necessary filtering.

For the remaining IDN parameter descriptions, refer to [Figure 117](#).

Figure 117 - Load Observer Gains

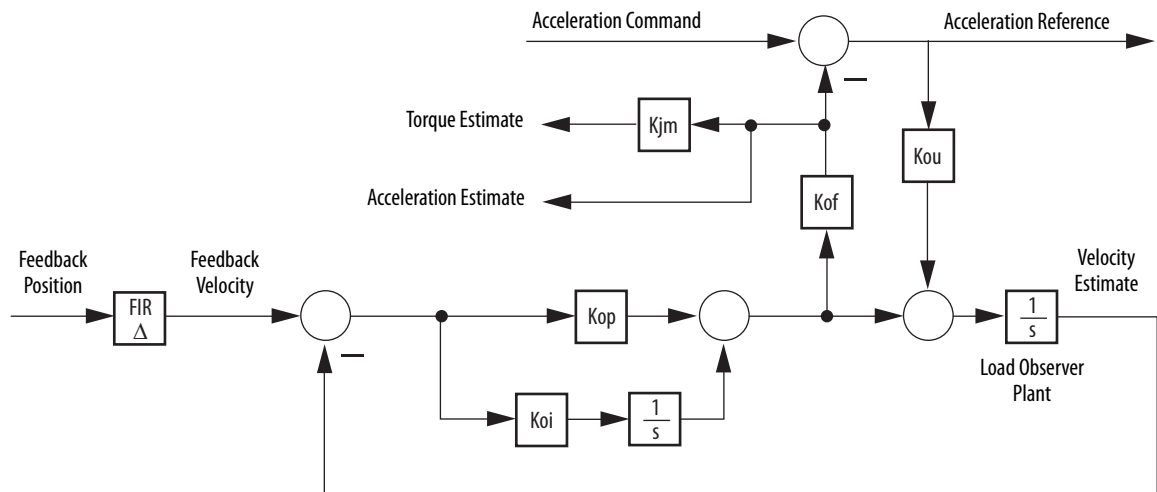

Load observer gains that require user interaction are Load Observer Bandwidth (Kop) and Load Observer Integral Bandwidth (Koi). They are set by IDN P-432 and IDN P-433, respectively. Guidelines for setting these gains are provided in the following sections. In general, Kop acts like a velocity integrator without windup and Koi acts like a position integrator without windup.

Load observer gains that do not require user interaction are Load Observer Feedback Gain (Kof) and the Load Observer Input Gain (Kou). They are automatically set internally based on the Load Observer Configuration. However, when in Acceleration Feedback mode, Kof can also be set manually by IDN P-434 with typical values between zero and one.

Table 123 - Load Observer Gain Parameters

IDN	Name	Units	Format	Value, min	Value, max
P:0:432	Load Observer Bandwidth (Kop)	Rad/s	16 bit unsigned int	0	12,500 ⁽¹⁾
P:0:433	Load Observer Integral Bandwidth (Koi)	Rad/s			65,535 ⁽²⁾
P:0:434	Load Observer Feedback Gain (Kof)	–			200

(1) This value applies to drive firmware revision 1.124.

(2) This value applies to drive firmware revisions later than 1.124.

The Acceleration Estimate and Torque Estimate signals are read by using IDN-435 and P-436, respectively. Definitions for these IDN parameters are given in the following table.

Table 124 - Load Observer Output Signals

IDN	Name	Units	Format	Value, min	Value, max
P:0:435	Load Observer Acceleration Estimate	Acceleration	32bit signed int	-2 ³¹	2 ³¹ -1
P:0:436	Load Observer Torque Estimate	Torque	16 bit signed int	-2 ¹⁵	2 ¹⁵ -1

When load observer and the torque low-pass filter are both enabled, and the low-pass filter bandwidth is less than 5 times the load observer bandwidth, their interaction can interfere with each other, causing instability. The low-pass filter is always limited to a bandwidth under 389 Hz in drive firmware prior to revision 1.116. As a result, an IDN parameter was added in drive firmware revision 1.116 to override the torque low-pass filter bandwidth limiting. The filter is also bypassed if the override IDN is set to one and the torque low-pass filter bandwidth is set to zero.

Table 125 - Torque Low-pass Filter Bandwidth

IDN P:0:065	Bandwidth in the Logix Designer Application	Actual Bandwidth in Drive	Drive Firmware Notes
0	= 0	389 Hz	Operation before revision 1.116
	> 0	Limited to ≤ 389 Hz	
1	= 0	Filter bypassed	Operation with revision 1.116 or later
	> 0	Limited to ≤ 10,430 Hz	

Refer to [Appendix E](#) on [page 249](#) for more information on changing IDN parameter values with read/write messages in the Logix Designer application.

Out-of-Box Gain Settings

This method of setting controller gains works for unknown loads or when an auto-tune is not performed. It produces a relatively high level of performance in 90% of motion applications. Most of the time, there is no need to perform an auto-tune procedure or further optimize gain settings. As a result, it has become the default out-of-box setting for Kinetix drives using integrated motion on the EtherNet/IP network.

Follow these steps to configure the drive for high performance right out of the box.

1. Create a new axis with type `AXIS_SERVO_DRIVE`.

If you need more information to create a new axis, refer to [Configure the Kinetix 6000 Drive Modules on page 144](#).

2. Click the Drive/Motor tab in the Axis Properties dialog box and add a motor.

If you need more information to add a motor, refer to [Configure Axis Properties on page 149](#).

3. Click the Gains tab in the Axis Properties dialog box.

The current Velocity Proportional Gain value is used to recalculate other gain values.

4. Make the following calculations:

- a. Load Observer Bandwidth: $Kop = \text{Velocity Proportional Gain} \times 2.56$
- b. Velocity Loop Bandwidth: $Kvp = Kop/4$
- c. Position Loop Bandwidth: $Kpp = Kvp/4$

5. Configure these settings and values on the Gains tab.
 - a. Position Proportional Gain = K_{pp}
 - b. Velocity Proportional Gain = K_{vp}
 - c. Velocity Feedforward Gain = 100%
 - d. Integrator Hold = Disabled

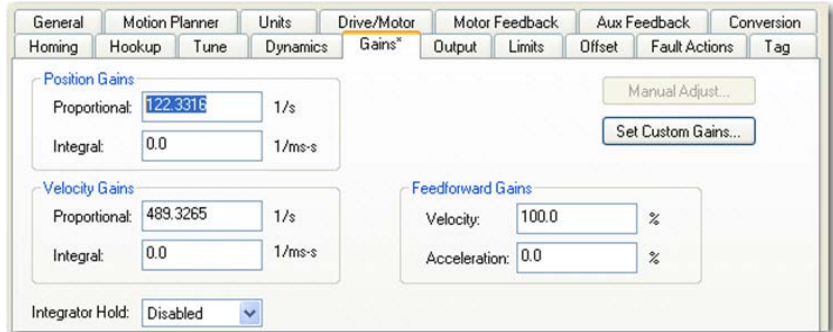

6. Configure these IDN parameter values.
 - a. IDN P-431 = 2 (load observer with velocity estimate)
 - b. IDN P-432 = K_{op}
 - c. IDN P-433 = 0
 - d. IDN P-065 = 1

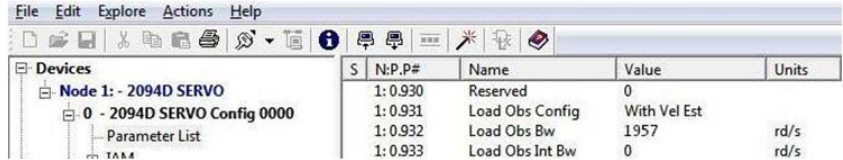

7. Click the Output tab in the Axis Properties dialog box and verify these settings.
 - a. Load Inertia Ratio = 0
 - b. Enable Low-pass Output Filter = Unchecked

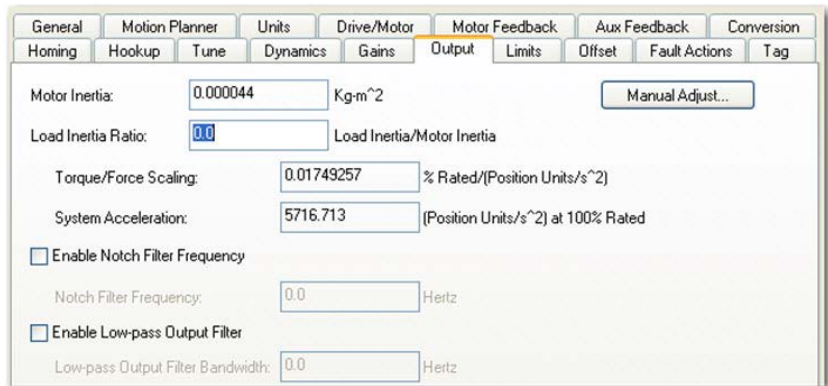

8. Refer to Compensate for High Frequency Resonances on [page 247](#), to tune-out resonant frequencies.

Auto-tune Gain Settings

This procedure explains how to configure the load observer feature after running Auto-tune. This method also works for any existing gain set where the Load Inertia Ratio is known or manually calculated, for example, the Load Inertia Ratio > 0 .

1. Click the Tune tab in the Axis Properties dialog box and perform Auto-tune.

For variable inertia loads, perform Auto-tune at the point of lowest mechanical inertia. If you manually calculate the Load Inertia Ratio, use the minimum load inertia.

2. Click the Output tab in the Axis Properties dialog box and verify that the Load Inertia Ratio > 0 .

Parameter	Value	Units
Motor Inertia	0.000044	Kg-m ²
Load Inertia Ratio	15.155865	Load Inertia/Motor Inertia
Torque/Force Scaling	0.2826076	% Rated/(Position Units/s ²)
System Acceleration	353.84753	(Position Units/s ²) at 100% Rated

3. Click the Gains tab in the Axis Properties dialog box.

The current Position and Velocity gain values are used to recalculate other gain values.

Gain Type	Parameter	Value	Units
Position Gains	Proportional	151.99413	1/s
	Integrat	5.7756	1/ms-s
Velocity Gains	Proportional	389.105	1/s
	Integrat	0.0	1/ms-s
Feedforward Gains	Velocity	100	%
	Acceleration	0.0	%
Integrator Hold		Disabled	

4. Determine if the mechanical load connected to the motor is rigid or compliant.
 - Rigid systems typically involve high-performance load mechanics that are tightly coupled directly to the motor shaft.
Refer to Rigid Mechanical Loads on [page 242](#), for rigid applications.
 - Everything else is compliant, including systems with belts and pulleys, long shafts, short shafts with heavy loads, and couplings and gearboxes with backlash and/or lost motion.
Refer to Compliant Mechanical Loads on [page 242](#), for compliant applications.

Rigid Mechanical Loads

Follow these steps if the load is rigid or the load observer feature is being added to a previously working set of gains with a Load Inertia Ratio > 0.

1. Calculate the Load Observer Bandwidth.
 Load Observer Bandwidth: $Kop = \text{Velocity Proportional Gain}$
2. If the Low-pass Output Filter is enabled, verify that the Low-pass Output Filter Bandwidth is \geq the Velocity Proportional Gain $\times 2/(2\pi)$.
3. Configure these IDN parameter values.
 - a. IDN P-431 = 2 (Load Observer with Velocity Estimate)
 - b. IDN P-432 = Kop
 - c. IDN P-433 = 0
 - d. IDN P-065 = 1

S	N:P,P#	Name	Value	Units
1:	0.930	Reserved	0	
1:	0.931	Load Obs Config	With Vel Est	
1:	0.932	Load Obs Bw	389	rd/s
1:	0.933	Load Obs Int Bw	0	rd/s

4. Refer to Compensate for High Frequency Resonances on [page 247](#), to tune-out resonant frequencies.

Compliant Mechanical Loads

Follow these steps if the load is compliant.

1. Make the following calculations:
 - a. Position Loop Bandwidth:
 $Kpp = \text{Position Proportional Gain}/(\text{Load Inertia Ratio} + 1)$
 - b. Position Integral Bandwidth:
 $Kpi = \text{Position Integral Gain}/(\text{Load Inertia Ratio} + 1)^2$
 - c. Velocity Loop Bandwidth:
 $Kvp = \text{Velocity Proportional Gain}/(\text{Load Inertia Ratio} + 1)$
 - d. Velocity Integral Bandwidth:
 $Kvi = \text{Velocity Integral Gain}/(\text{Load Inertia Ratio} + 1)^2$
 - e. Load Observer Bandwidth: $Kop = Kvp$

2. Configure these settings and values on the Gains tab.

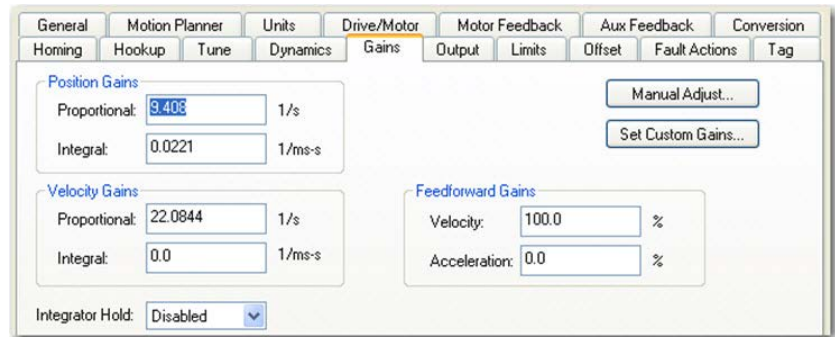

- a. Set the Position Proportional Gain = K_{pp}
 - b. Position Integral gain = K_{pi}
 - c. Velocity Proportional Gain = K_{vp}
 - d. Velocity Integral Gain = K_{vi}
3. If the Low-pass Output Filter is enabled, verify that the Low-pass Output Filter Bandwidth \geq Velocity Proportional Gain $\times 5/(2\pi)$.

The compliant setting reduces all of the gains by a factor of the Load Inertia Ratio +1 and then calculates the Load Observer Bandwidth. Typically, this reduction is too conservative, making the loop response too sluggish and the error too large, however, it does provide stability.

To manually increase the gains by some factor to optimize the response, refer to Manual Tuning for Further Optimization on [page 244](#).

4. Configure these IDN parameter values.
- a. IDN P-431 = 2 (Load Observer with Velocity Estimate)
 - b. IDN P-432 = K_{op}
 - c. IDN P-433 = 0
 - d. IDN P-065 = 1

S	N:P.P#	Name	Value	Units
1:	0.930	Reserved	0	
1:	0.931	Load Obs Config	With Vel Est	
1:	0.932	Load Obs Bw	389	rd/s
1:	0.933	Load Obs Int Bw	0	rd/s

5. Refer to Compensate for High Frequency Resonances on [page 247](#), to tune-out resonant frequencies.

Tuning Mode Summary

This table summarizes the primary difference between the two tuning modes.

Table 126 - Tuning Mode Comparison

Tuning Mode	Description
Out-of-box or unknown load Load Inertia Ratio = 0	Load Observer Bandwidth $Kop = 4$ times the new Velocity Proportional Gain, Kvp
Auto-tuning or known load Load Inertia Ratio > 0	Load Observer Bandwidth = Velocity Proportional Gain

Manual Tuning for Further Optimization

The out-of-box and auto-tune rigid methods achieve relatively high performance. However, the manual tuning method can help to optimize performance for the auto-tune compliant method, or if every ounce of performance is required. It involves incrementally increasing controller gains to the point of marginal stability, then backing them off by a given percentage. Typical ranges for various gains are also given to provide guidelines.

Follow these steps to manually tune your drive.

1. Select a factor (N) that you can incrementally increase the gains by in an iterative process, for example, $1.5 > N > 2$.
2. Create a trend to monitor Torque Reference.
3. Manually tune the velocity loop.
 - a. Make note of the Position and Feedforward Gains.
You must change them temporarily to isolate the velocity loop and later restore them to the original values.
 - b. Isolate the velocity loop.
 - Zero out the Position Proportional Gain, Position Integral Gain, and Acceleration Feedforward Gain
 - Set the Velocity Feedforward = 100
 - c. While Jogging the axis and monitoring the Torque Reference trend, incrementally increase the following gains simultaneously and stop when the Torque Reference begins to become oscillatory or unstable:
 - Low-pass Output Filter Bandwidth = Low-pass Output Filter Bandwidth $\times N$
 - Load Observer Proportional Gain = Load Observer Proportional Gain $\times N$
 - Load Observer Integral Gain = Load Observer Integral Gain $\times N$
 - Velocity Proportional Gain = Velocity Proportional Gain $\times N$
 - Velocity Integral Gain = Velocity Integral Gain $\times N^2$

- d. Decrease the gains by using the previous equations with $N = 0.5$.
A typical range of values for various integral gains are given:
 - $0 \leq \text{Load Observer Integral Gain} \leq \text{Load Observer Proportional Gain}/4$
 - $0 \leq \text{Velocity Integral Gain} \leq \text{Velocity Proportional Gain}^2/4000$
 - e. If the Low-pass Output Filter is enabled, a typical range of values for the Low-pass Output Filter Bandwidth are given:
 - Rigid: $\text{Low-pass Output Filter Bandwidth} \geq \text{Velocity Proportional Gain} \times 2/(2\pi)$
 - Compliant: $\text{Low-pass Output Filter Bandwidth} \geq \text{Velocity Proportional Gain} \times 5/(2\pi)$
4. Manually tune the position loop.
- a. Restore the Position and Feedforward Gains to the original values to re-enable the position loop.
 - b. While Jogging the axis and monitoring the Torque Reference trend, incrementally increase the following gains simultaneously and stop when the Torque Reference begins to become oscillatory or unstable:
 - $\text{Position Proportional Gain} = \text{Position Proportional Gain} \times N$
 - $\text{Position Integral Gain} = \text{Position Integral Gain} \times N^2$
 - c. Decrease the gains by using the previous equations with an $N = 0.5$.
A typical range of values for the Position Integral Gain is given:
 $0 \leq \text{Position Integral Gain} \leq \text{Position Proportional Gain}^2/4000$

Setting Gains with Sercos IDN Write Messages

Write the Load Observer Configuration attribute and the Load Observer gains each time the drive gets initialized after applying power.

The Sercos IDN write instruction is accomplished by using RSLogix 5000 software or the Logix Designer application. Refer to [Appendix E](#) on [page 249](#) for more information on changing IDN parameter values by using this method.

1. Upon initialization of the drive, read the INT value of the configuration of the drive at Sercos IDN P:0:431.

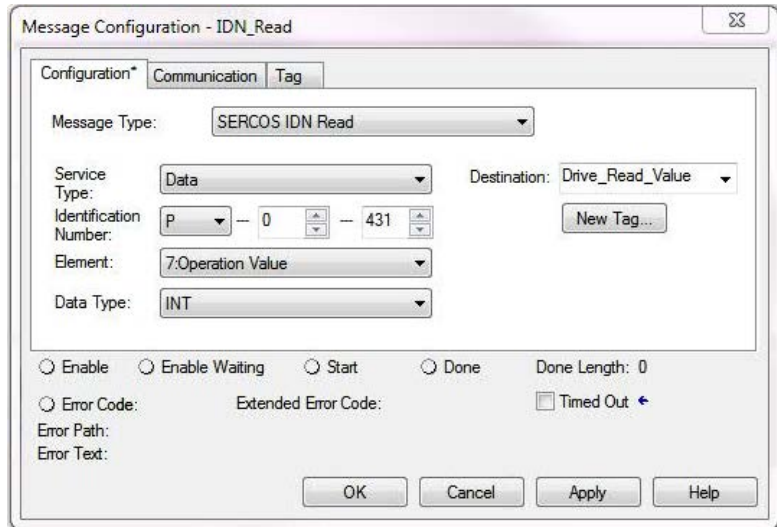

2. If the value is not what you want, latch it and write the new value back to the drive at the same address, again as type INT.

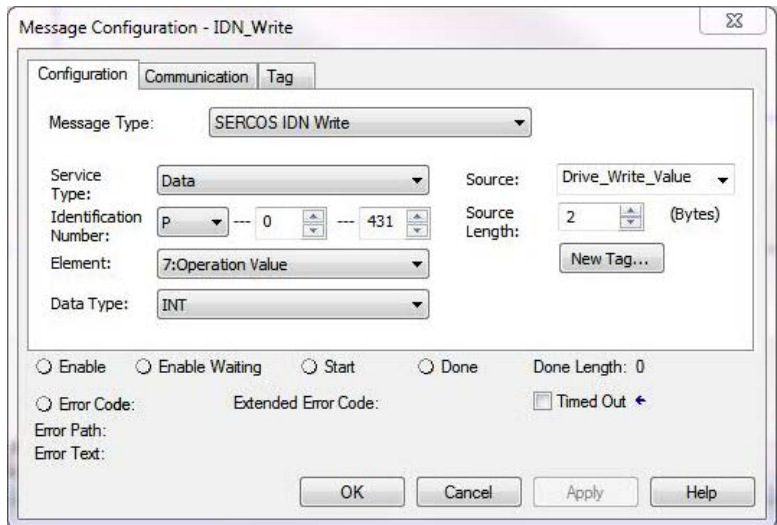

3. Verify the change with another sercos IDN Read Message from IDN P:0:431.

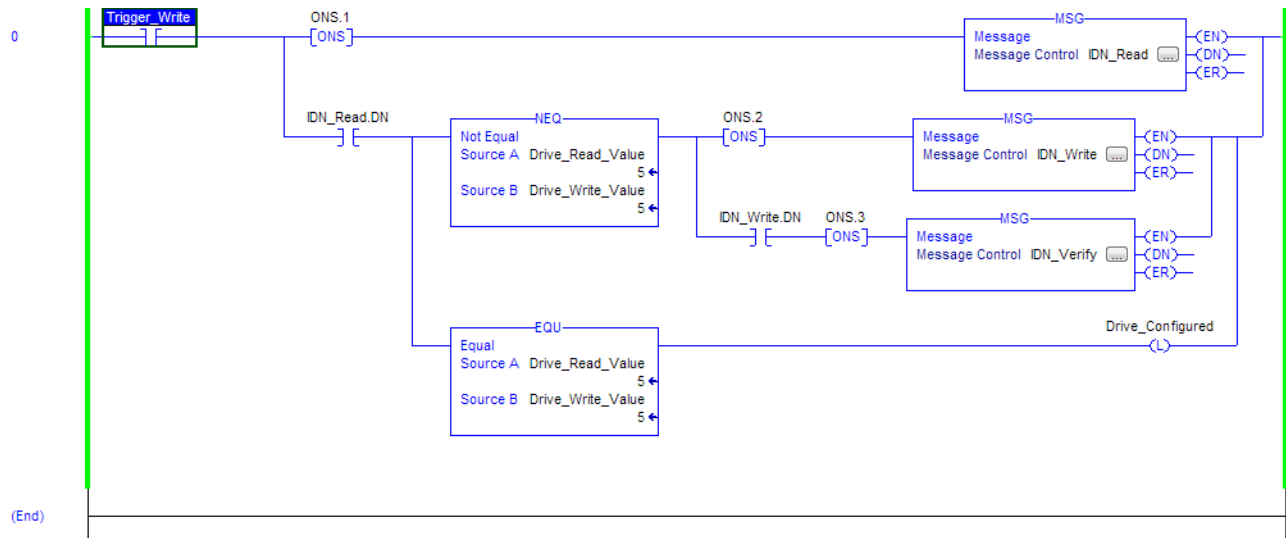

TIP The procedure for setting each of the gains is similar.

Compensate for High Frequency Resonances

Approximately 15% of all motion applications exhibit a high-frequency resonance that is apparent by an audible high-frequency squealing of the load mechanics.

Follow these steps to identify and reduce the presence of high-frequency resonances.

1. Perform the following move sequence by using Motion Direct Commands:
 - a. Enable the axis with an MSO
 - b. Slowly jog the axis with an MAJ
 - c. Stop the axis with an MAS
 - d. Disable the axis with a MSO

IMPORTANT Sometimes an audible resonance is heard before the axis is jogged, making the MAJ and MAS unnecessary.

2. Determine if an audible high-frequency resonance exists in your motion application.
 - If an audible high frequency resonance is not present during the move sequence, skip the remaining steps and tuning is complete.
 - If an audible high frequency resonance is present during the move sequence, use an FFT smart phone or tablet application to identify the dominant resonant frequencies.

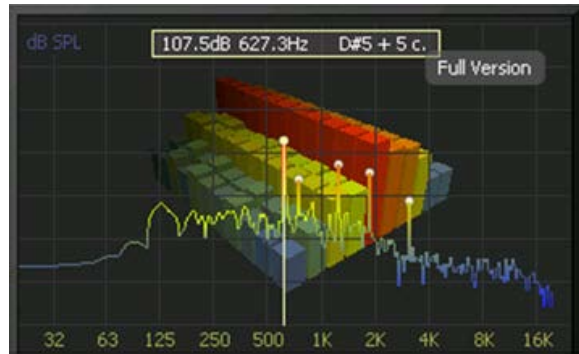

3. Click the Output tab in the Axis Properties dialog box.

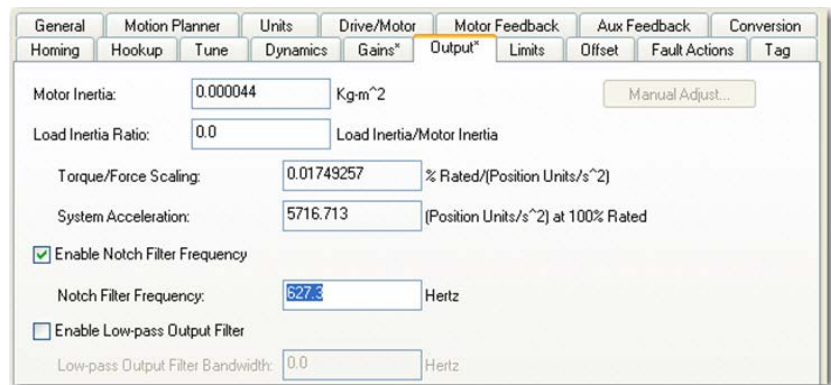

- a. Check Enable Notch Filter Frequency and set the Notch Filter Frequency to the resonant frequency with the largest amplitude.
- b. If multiple resonances have nearly the same amplitude, set the Notch Filter Frequency to the lowest resonant frequency.
- c. If the problem persists, also check Enable Low-pass Output Filter and set the Low-pass Output Filter Frequency to the next largest resonant frequency.
- d. Click OK.

Changing the Default IDN Parameter Values

This appendix provides a procedure, specific to the Kinetix 6000 (sercos) drive systems, for changing IDN parameter values to non-default values when your application does not match the default configuration. The procedure also applies when one or more Kinetix 6000M IDM systems are present.

Topic	Page
Before You Begin	249
Change IDN Parameter Values	250

Before You Begin

The Logix5000 processor contains a motion planner that sends real-time and non real-time data to the drive. This drive communication is performed via a set of sercos interface telegrams. Each telegram has an identification or Ident (IDN) number. All parametric data, such as scaling and loop gains, and real-time loop closure information is configured this way.

Table 127 - IDN Instruction Format in the IEC Standard Document

IDN Number	Name			
	Function/Description			
	Length in bytes	Minimum input value/ Maximum input value	Scaling/resolution	Units

There are default parameters in the Logix5000-to-Kinetix 6000 drive product structure you can reconfigure when the default configuration does not match the Integrated Architecture™ machine configuration.

By using this procedure, you can change the Additional Bus Capacitance value in common-bus configurations.

TIP You can also set the Additional Bus Capacitance parameter by using DriveExplorer software (refer to [Appendix C](#)), the Logix Designer application, or RSLogix 5000 software, version 20.00 or later, from I/O configuration>Sercos module>Drive module properties>Power tab (refer to [Chapter 6](#)).

Use this flowchart to determine if changing your default configuration is required.

Figure 118 - Configuration Flowchart

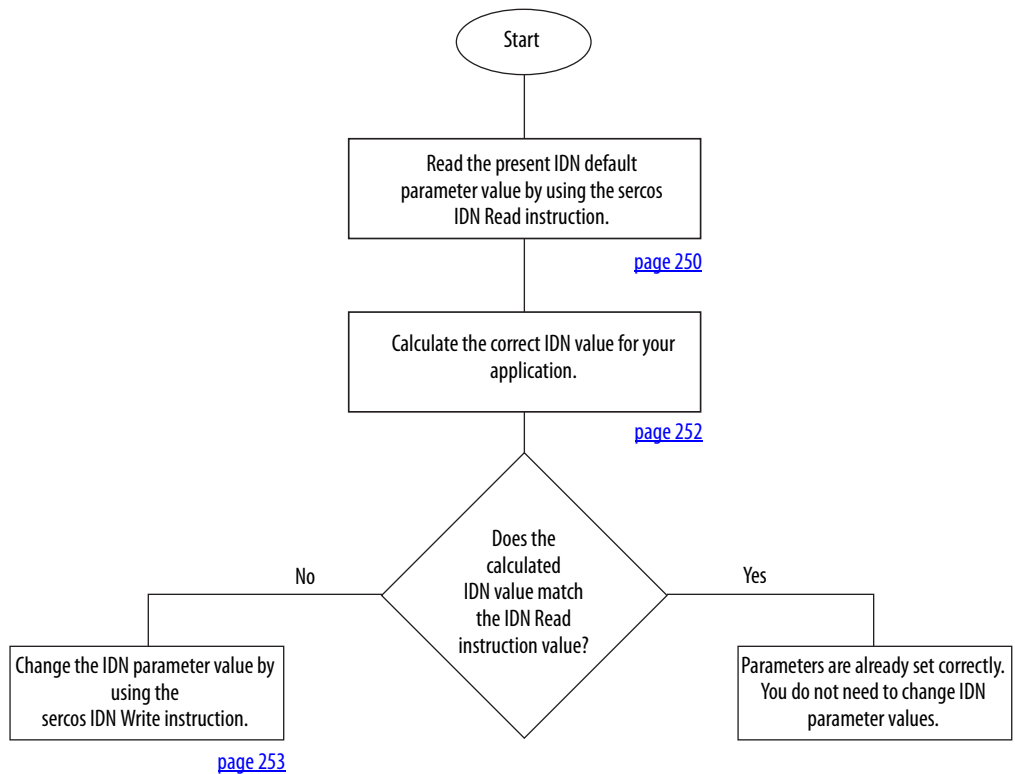

Change IDN Parameter Values

In this section you follow the Configuration Flowchart on [page 250](#) to determine if you need to use the sercos IDN Write instruction in the Logix Designer application to change the IDN parameter values.

Read the Present IDN Parameter Value

Follow these steps to read the present IDN value.

1. Start your Logix Designer application program.
2. Configure a Message Configuration (MSG) instruction to read your present IDN parameter values.

In this example, the Message Configuration (MSG) instruction is set to read the additional bus capacitance of your leader IAM power module.

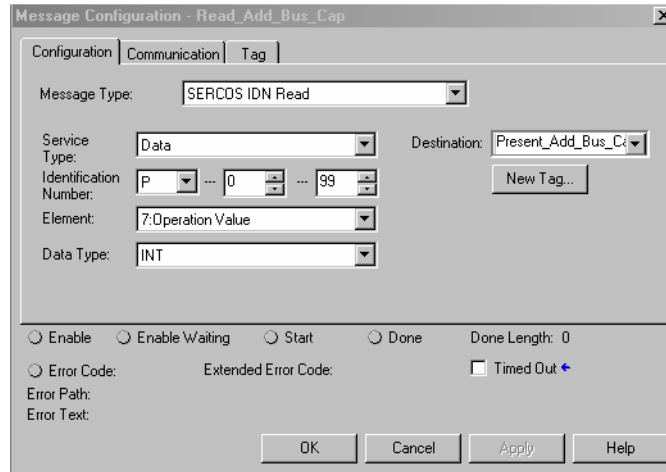

- a. From the Message Type pull-down menu, choose sercos IDN Read.
 - b. From the Identification Number pull-down menus, choose P-0-99.
3. Click New Tag.
 4. The New Tag dialog box opens.



5. Type the name of your Destination tag.
In this example, the tag name is Read_Value.

6. Click OK.

In this example, the MSG instruction reads the P-0-99 IDN value and places it in the destination as specified by the new tag.

7. Click the Communication tab.

8. Click Browse.

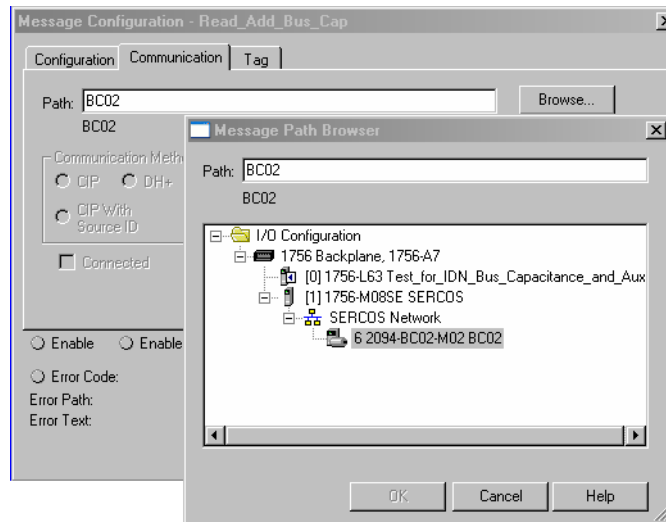

9. Select the Bulletin 2094 module to read the MSG instruction.
10. Click OK.

Calculate the New IDN Value

Changing the additional bus capacitance value requires calculations. Determine the sum of all capacitance values for the follower IAM module, each AM module, and each IPIM module on the follower IAM power rail.

Refer to Calculate Additional Bus Capacitance on [page 227](#) for more information.

Write the New IDN Parameter Value

Follow these steps to write the new IDN parameter value.

1. Configure a Message Configuration (MSG) instruction to write the IDN parameter value required for your application.

In this example, the Message Configuration (MSG) instruction is set to write the additional bus capacitance of your leader IAM power module.

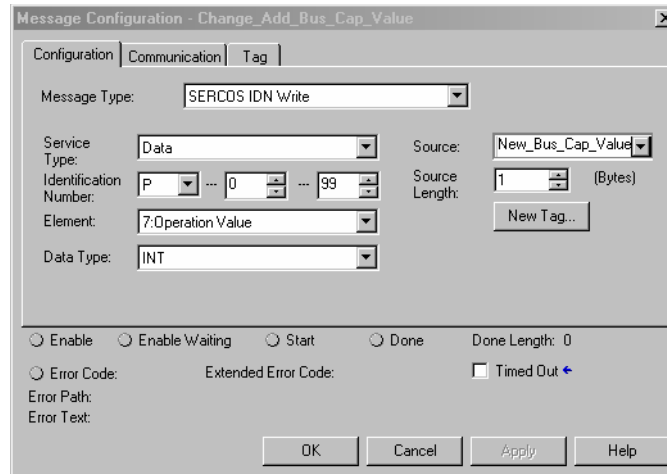

- a. From the Message Type pull-down menu, choose sercos IDN Write.
 - b. From the Identification Number pull-down menus, choose P-0-99.
2. Click New Tag.
 3. The New Tag dialog box opens.

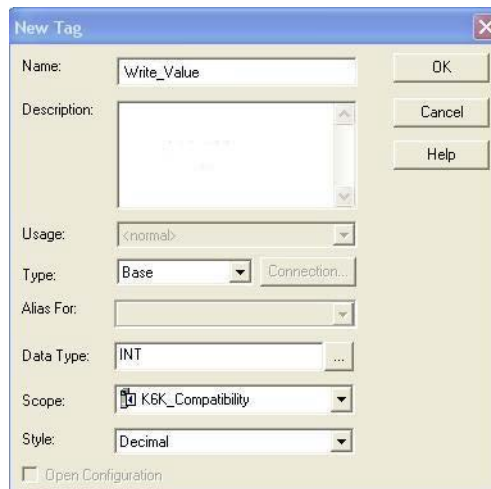

4. Type the name of your Source tag.
In this example, the tag name is Write_Value.
5. Click OK.

In this example, the new tag creates a source value (that you entered) that the MSG instruction uses to overwrite the existing P-0-099 IDN value.

6. Click the Communication tab.

The Communication tab opens.

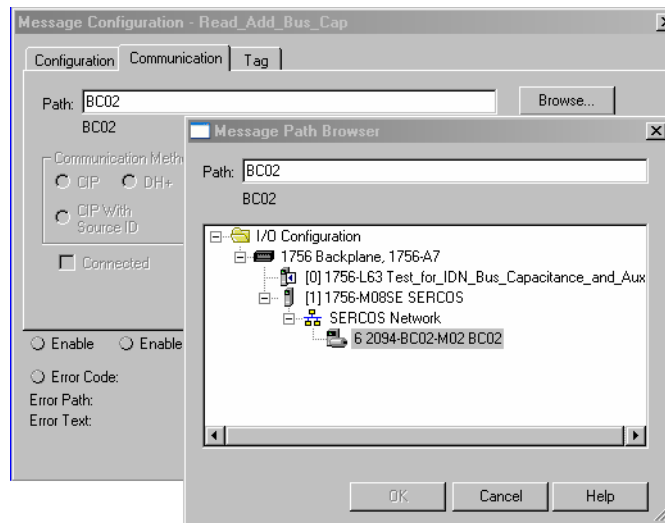

7. Click Browse.
8. Select your Bulletin 2094 module.
9. Click OK.

The MSG instruction writes the new IDN value to your drive.

TIP To verify your sercos IDN Write instruction was successful, you can perform another sercos IDN Read instruction for the IDN in question.

10. Click OK to close the Message Configuration dialog box.

Enhanced Peak Performance

This appendix provides procedures and information, specific to the Kinetix 6000 drive systems, for enabling the peak enhancement feature in each drive.

Topic	Page
Before You Begin	255
Enhanced Peak Example	257
Change the Drive Parameter	262

Before You Begin

The peak current ratings of the Kinetix 6000 460V drives (series A, B, and C) are configured at the factory as 150% of continuous current. However, you can program 460V (series B and C) AM modules and the equivalent IAM (inverter) modules, for up to 250% of continuous inverter current.

To achieve the enhanced peak performance, you must determine the values of maximum acceleration, deceleration, and torque. This feature is present only in the Kinetix 6000 (series B and C) drives listed in [Table 128](#).

Table 128 - Kinetix 6000 Series Change

IAM Module Cat. No.	AM Module Cat. No.	Peak Current Rating	
		Series A (inverter)	Series B and C (inverter)
2094-BC01-MP5-S	2094-BMP5-S	150%	250%
2094-BC01-M01-S	2094-BM01-S	150%	250%
2094-BC02-M02-S	2094-BM02-S	150%	250%
2094-BC04-M03-S	2094-BM03-S	150%	250%
2094-BC07-M05-S	2094-BM05-S	150%	200%

The default values that populate the AXIS_SERVO_DRIVE properties in the Logix Designer application are calculated for each motor and drive, but assume 150% peak torque in those calculations. For the drive to command more current, you must enter new values for some of those parameters, including the following:

- TorqueLimitBipolar
- TorqueLimitPositive
- TorqueLimitNegative
- MaximumAcceleration
- MaximumDeceleration
- AccelerationLimitBipolar
- AccelerationLimitPositive
- AccelerationLimitNegative

You can access these parameters offline in the Logix Designer application Axis Properties tabs or online as sent to the drive in an SSV instruction.

To calculate the new values, you also need to determine these values:

- Drive electrical data (Motion Analyzer solution page, under Drive tab)
- Motor electrical data (Motion Analyzer solution page, under Motor tab)
- TorqueScaling (the Logix Designer application, Axis Properties, Output tab)

Figure 119 - Drive and Motor Data in Motion Analyzer Software

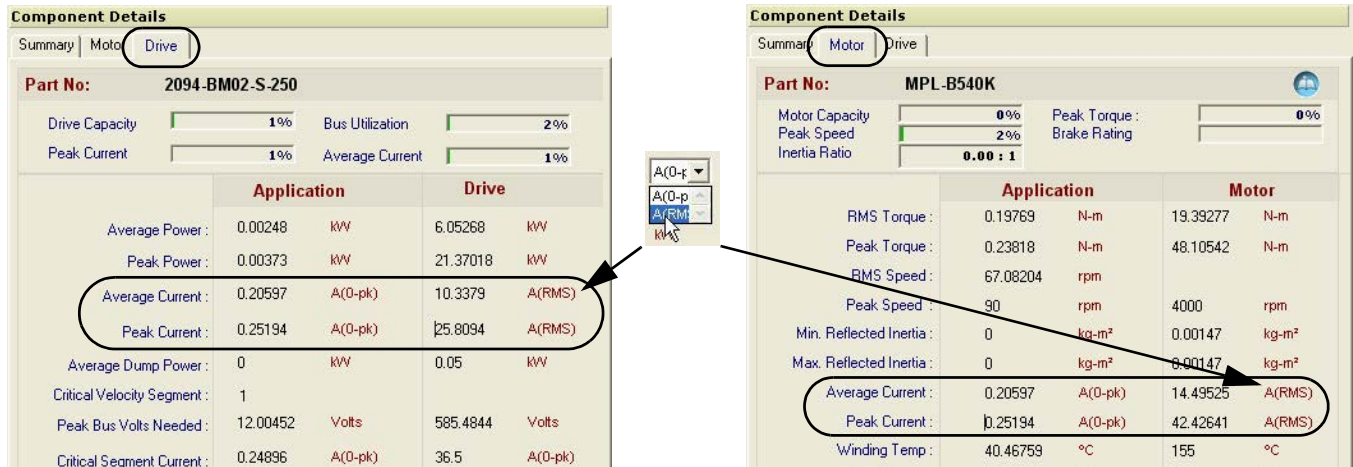

IMPORTANT

The default unit in Motion Analyzer software for drive and motor current is A (0-pk). Because the example formula is in A (RMS), you must change the units in the Drive and Motor tabs to A (RMS).

Pause your mouse over A (0-pk) and use the pull-down menu to change the units to A (RMS). Refer to [Figure 119](#) for an example.

Enhanced Peak Example

In this example, the following motor and drive combination is used:

- Drive = 2094-BC02-M02-S
- Motor = MPL-B540K

Table 129 - Example Definitions

Description	Symbol	IDN	Example
Motor continuous current (A_{rms})	$I_{mtr, cont}$	S:0:0111	14.49525
Motor peak current (A_{rms})	$I_{mtr, pk}$	S:0:0109	42.42641
Drive continuous current (A_{rms})	$I_{dr, cont}$	S:0:0112	10.3379
Drive peak current (A_{rms})	$I_{dr, pk}$	S:0:0110	150%: 15.5069
			250%: 25.8094

Figure 120 - Example Torque Formula

$$\text{Torque}_{max} = \frac{\min(I_{mtr, pk}, I_{dr, pk})}{I_{mtr, cont}} = \frac{\min(42.4 A_{rms}, 25.8 A_{rms})}{14.5 A_{rms}} = 178.1\%$$

1. Navigate to Axis Properties and click the Limits tab.

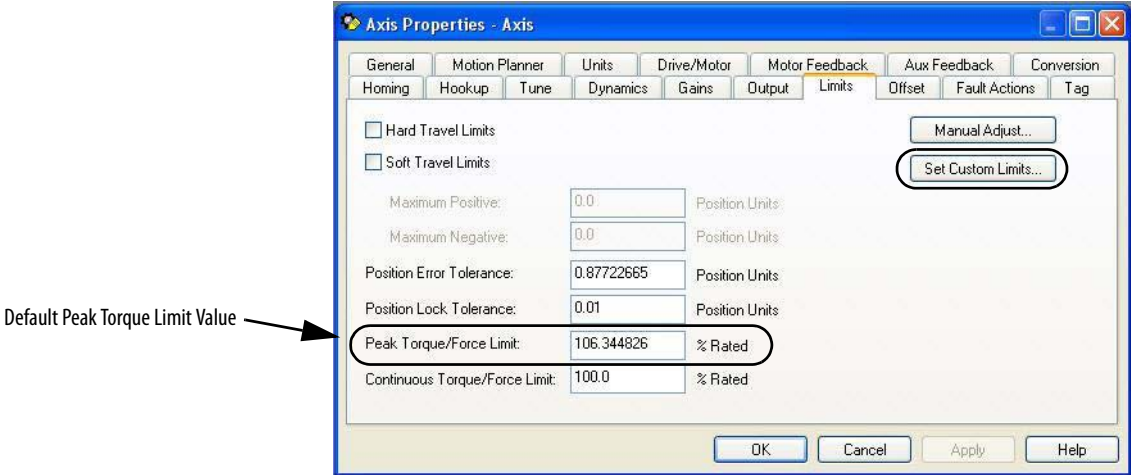

2. Overwrite the existing Peak Torque Limit (TorqueLimitBipolar) value. In this example, the calculated value is 178.1.
3. Click Set Custom Limits.

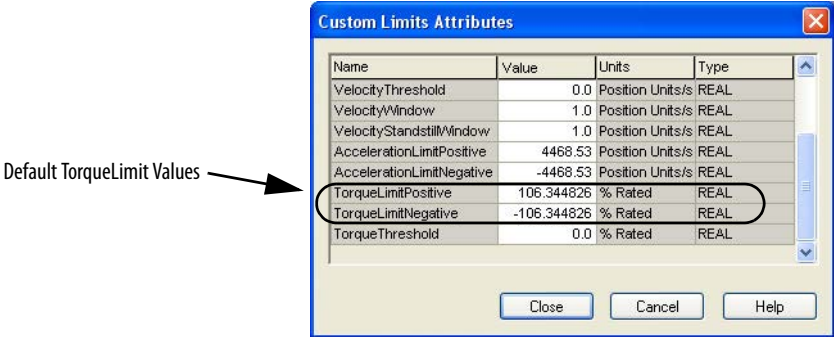

4. Overwrite the existing TorqueLimitPositive and TorqueLimitNegative values.

In this example, the calculated values are 178.1 and -178.1 (respectively).

The calculated value for $Torque_{max}$ is the maximum value for the following:

- TorqueLimitBipolar
- TorqueLimitPositive (+)
- TorqueLimitNegative (-)

If you want to limit the torque, adjust the calculated values to a value closer to zero. The values shown are the default values for 150% peak torque with this motor and drive pair.

TIP For more information on system configuration with your Logix5000 controller and the Logix Designer application, refer to [page 133](#).

5. Click the Output tab.

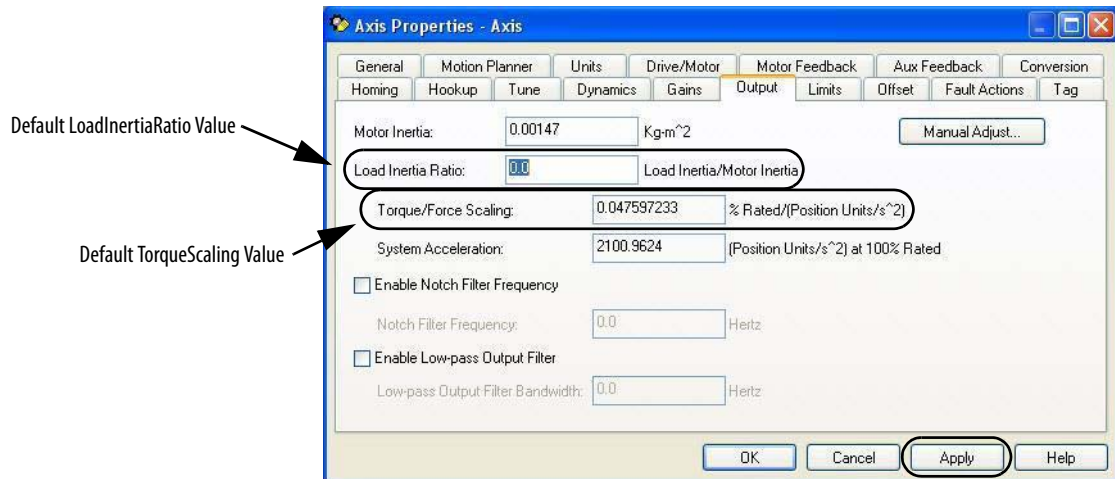

The TorqueScaling and LoadInertiaRatio values are populated after an autotune. If an autotune is not possible, model the system in Motion Analyzer software and enter that value for the LoadInertiaRatio. The default value for the LoadInertiaRatio is 0.0, however for this example, a ratio of 10.20:1 is used (load inertia = 0.015 Kg-m²).

IMPORTANT To obtain more accurate results, performing Autotune in the Logix Designer application is recommended.

To calculate the maximum acceleration and deceleration from $Torque_{max}$, use this equation.

$$Accel_{max} = Torque_{max} \cdot \frac{100}{TorqueScaling}$$

TIP If autotune cannot be performed, enter the data for the LoadInertiaRatio, DriveResolution, and ConversionConstant as shown in [step 5](#) through [step 9](#).

- 6. Change the Load Inertia Ratio value to 10.2.
- 7. Click Apply.

The TorqueScaling values update.

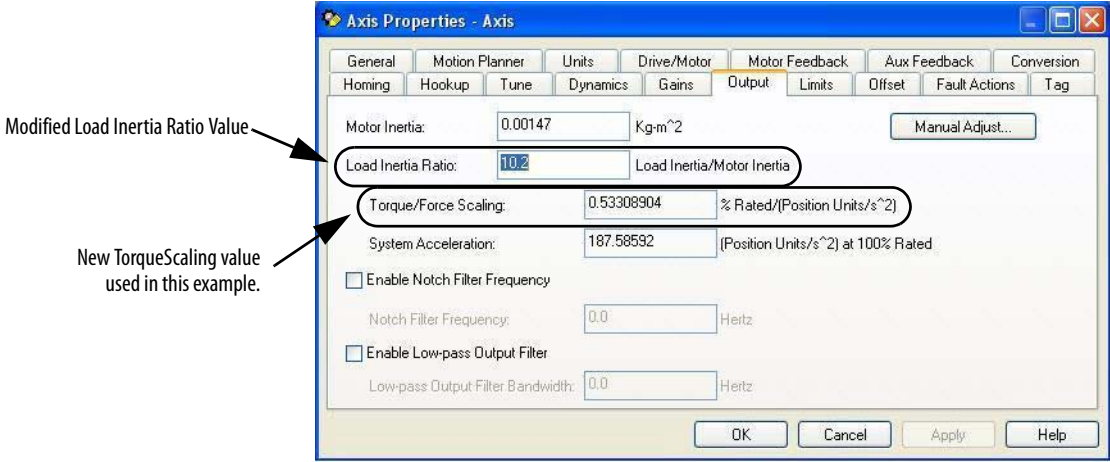

- 8. Click the Drive/Motor tab.

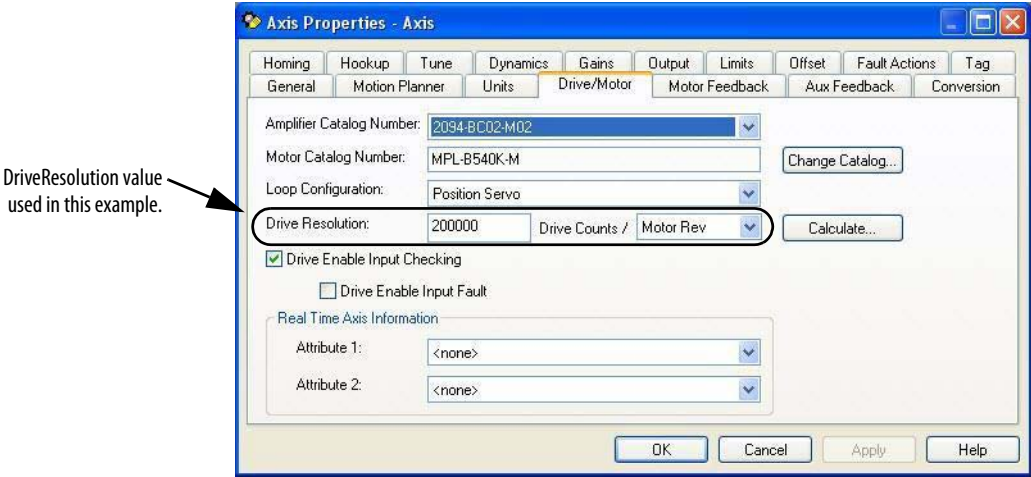

The values for DriveResolution and ConversionConstant start out populated with default values, but can be changed for your specific needs. If you plan to change those values, enter the new values into the dialog boxes. Otherwise, use the defaults.

- 9. Click the Conversion tab.

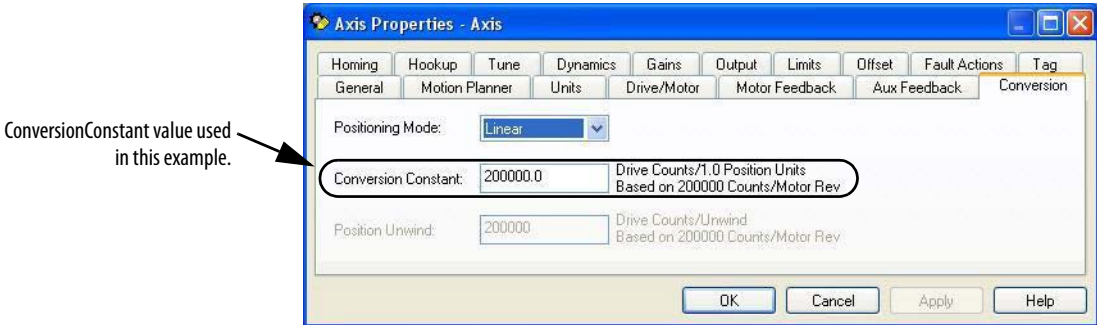

Enhanced Peak Example Calculation

Based on the values shown, this is the sample calculation.

$$\text{Accel}_{\max} = 1.781 \cdot \frac{100}{0.53308904 \frac{\% \text{ rated}}{\text{PU/s}^2}} = 334.09 \text{ PU/s}^2$$

To provide safe headroom, this value needs to be reduced by 15% before being written to the controller. This is the sample calculation.

$$\text{MaximumAcceleration} = \text{MaximumDeceleration} = 0.85 \cdot \text{Accel}_{\max} = 283.98 \text{ PU/s}^2$$

1. Click the Dynamics tab.

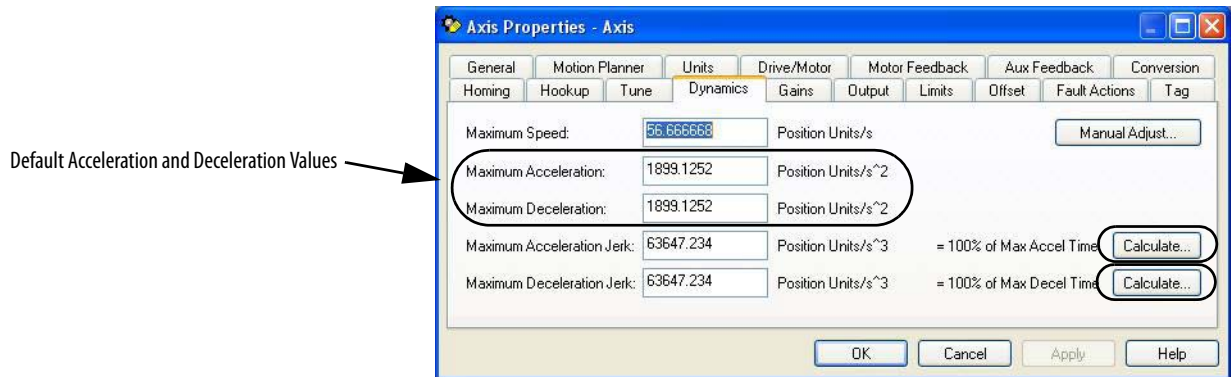

2. Overwrite the existing Maximum Acceleration and Maximum Deceleration values.

In this example, the calculated values are 283.98 for each.

3. Click Calculate for the Maximum Acceleration Jerk and Maximum Deceleration Jerk fields to automatically calculate new values.
4. Adjust the new jerk values for your specific application needs.

Setting the values for AccelerationLimitBipolar, AccelerationLimitPositive, and AccelerationLimitNegative requires one more calculation by using this formula.

$$\begin{aligned} \text{AccelerationLimitBipolar} &= \text{AccelerationLimitPositive} = -\text{AccelerationLimitNegative} \\ \text{AccelerationLimitBipolar} &= \frac{2 \cdot \text{MaximumAcceleration}}{0.85} = 668.18 \text{ PU/s}^2 \end{aligned}$$

5. Click the Limits tab.

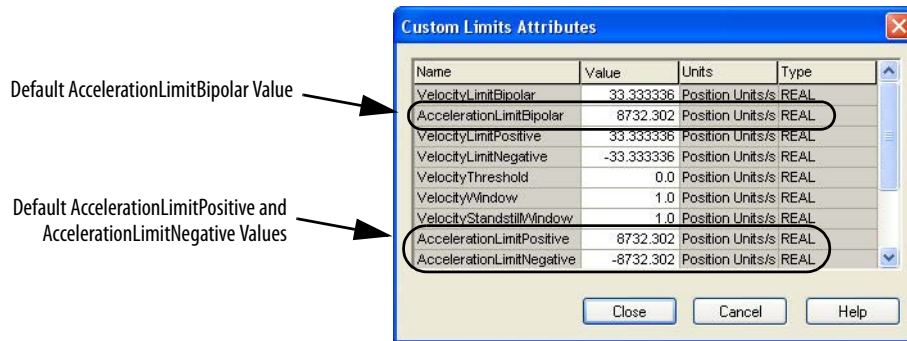
6. Click Set Custom Limits.**7.** Overwrite the existing AccelerationLimitBipolar value.

In this example, the calculated value is 668.18.

8. Overwrite the existing AccelerationLimitPositive and AccelerationLimitNegative values.

In this example, the calculated values are +668.18 and -668.18 (respectively).

9. Repeat this process for each IAM and AM module in your system.

Change the Drive Parameter

Before the drive is capable of accepting a command for the new peak current ratings, you need to change a drive parameter. This needs to be done only once, and there are two methods to perform the task.

IMPORTANT The sercos IDN method that uses the Logix Designer application supports automatic drive replacement (ADR).

Sercos IDN Write Instruction

The sercos IDN write instruction is accomplished by using the Logix Designer application. Refer to [Appendix E](#) on [page 249](#) for more information on changing IDN parameter values by using this method.

1. On initialization of the drive, read the INT value of the configuration of the drive at sercos IDN P:0:7.



2. If the value of bit zero is zero, latch it and write the new value back to the drive at the same address, again as type INT.

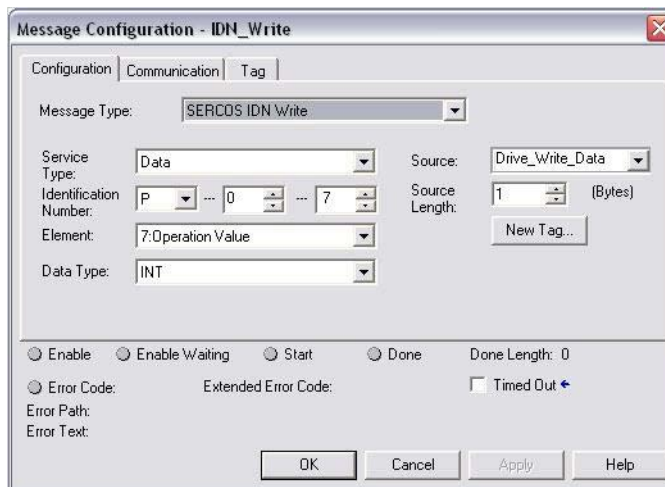

3. Verify change with another sercos IDN Read Message from IDN P:0:7 and examine bit zero.

Refer to this Logix Designer application example.

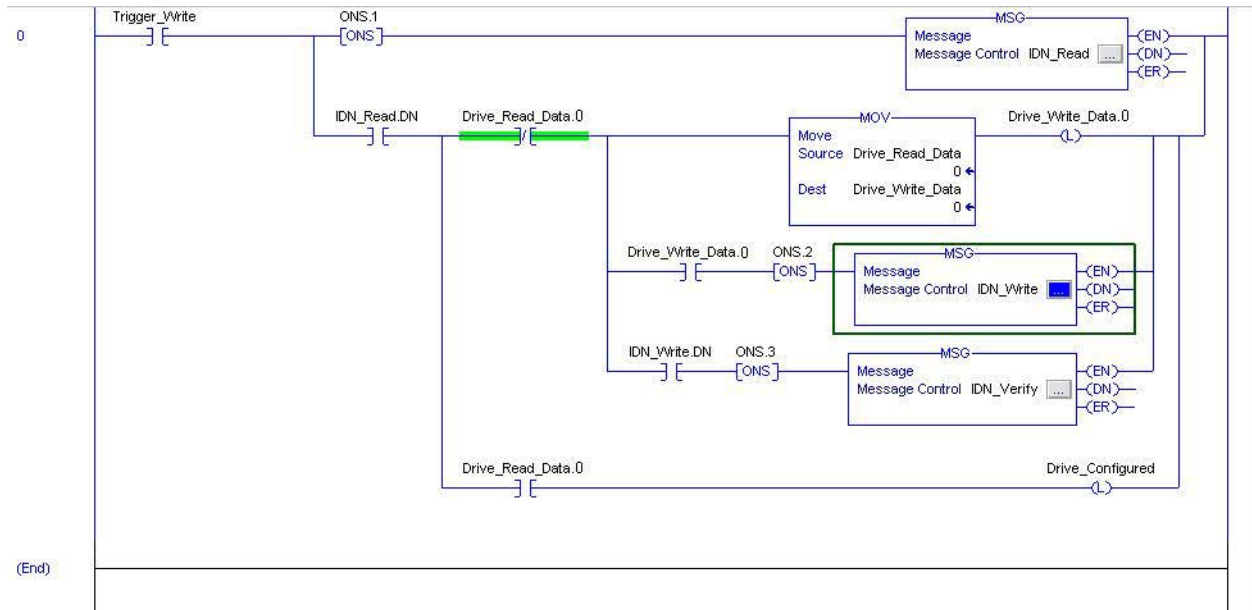

DriveExplorer Software

To use DriveExplorer software to change IDN parameter values, you must also have the 1203-SSS Serial to SCANport adapter. Refer to [Appendix C](#) on [page 225](#) for more information on changing IDN parameter values by using this method.

1. Connect a 1203-SSS Serial to SCANport adaptor to the drive by using DriveExplorer software.
2. Change parameter P507 [Drv Peak Rating] from 150% to 250% (or 200% if applicable).
3. Save device values to nonvolatile memory.

Notes:

RBM Module Interconnect Diagrams

This appendix provides Bulletin 2090 Resistive Brake Module (RBM) interconnect diagrams specific to Kinetix 6000 multi-axis servo-drive systems with and without the safe torque-off feature.

Topic	Page
Before You Begin	265
RBM Module Wiring Examples	266

Kinetix 6000 drives with the safe torque-off feature have the -S designation at the end of the catalog number. For example, the 2094-AM01-S AM module includes safe torque-off and the 2094-AM01 AM module does not.

Before You Begin

These procedures assume you have installed your RBM module with the Kinetix 6000 servo-drive system. For RBM module installation instructions, refer to the Resistive Brake Module Installation Instructions, publication [2090-IN009](#).

IMPORTANT Drive firmware revision 1.071 or later is required to use the RBM module with Kinetix 6000 drives.



ATTENTION: Use the interconnection diagrams as a general recommendation on how the safety control circuit can be implemented. Actual applications can vary due to requirements based on the machine builders risk assessment. The machine builder must perform a risk assessment and determine a category level of safety that must be applied to the machine.

For Kinetix 6000 drive systems, you can set the delay time for your RBM module in the Logix Designer application. Refer to Configure Axis Properties on [page 149](#).

RBM Module Wiring Examples

This example diagram shows 2094-xCxx-Mxx-S and 2094-xMxx-S drives (with safe torque-off) and 2094-ALxxS, 2094-BLxxS, and 2094-XL75S LIM modules wired with the Bulletin 2090 RBM module.

Figure 121 - RBM Wiring Example

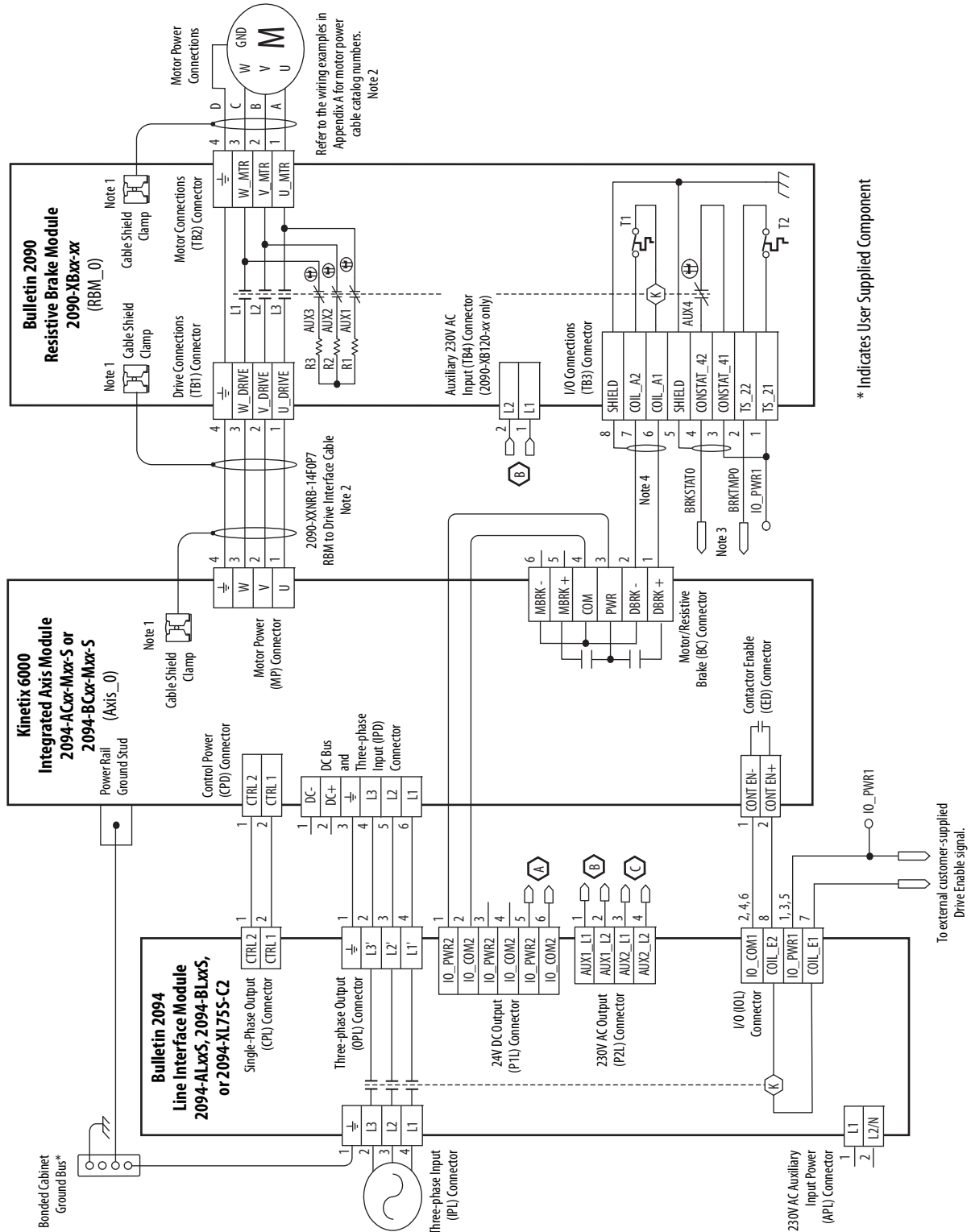

* Indicates User Supplied Component

RBM Wiring Example (continued)

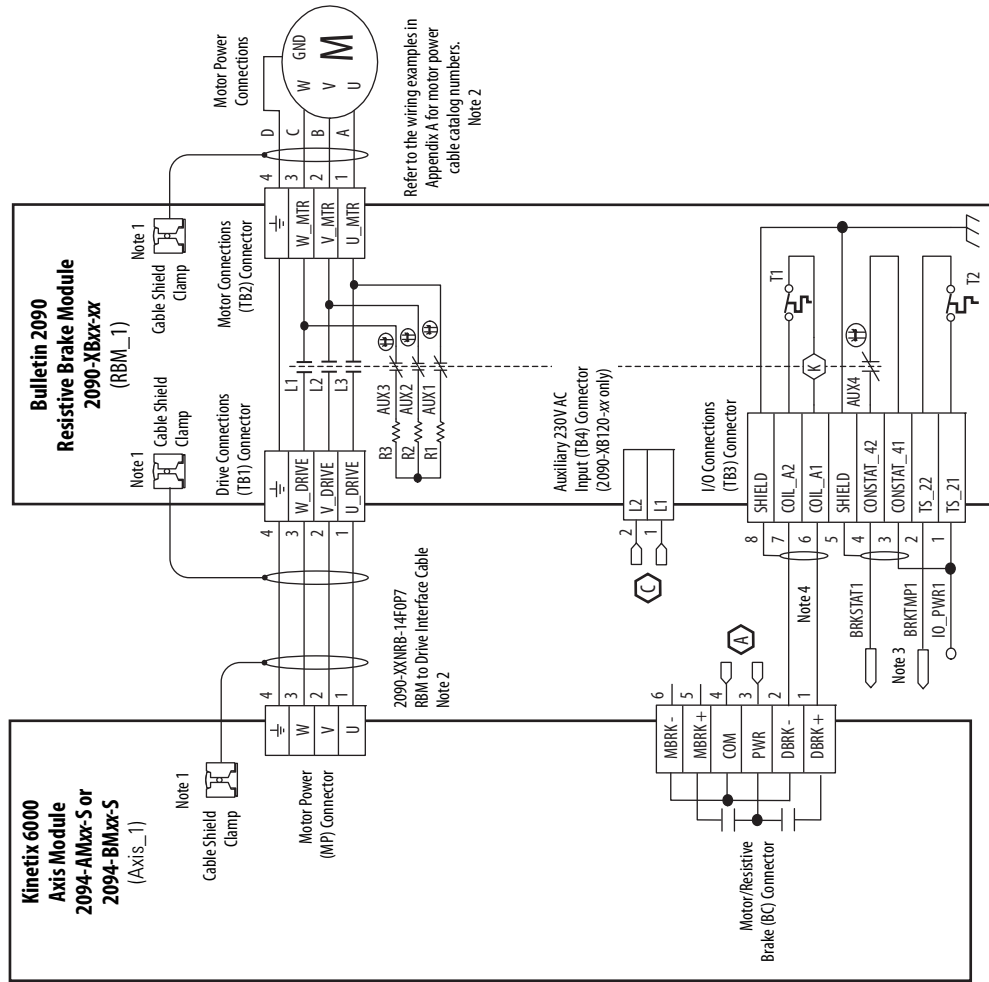

* Indicates User Supplied Component

ATTENTION: The National Electrical Code and local electrical codes take precedence over the values and methods provided. Implementation of these codes is the responsibility of the machine builder.



Note	Information
1	Cable shield clamp must be used to meet CE requirements. No external connection to ground required.
2	For motor cable specifications, refer to the Kinetix Motion Accessories Technical Data, publication GMC-1D004 .
3	The BRKTMPO signal can be wired to a ControllLogix input as overtemp warning in user program.
4	Firmware revision 1.071 or later is required to use the DBRK outputs on the Kinetix 6000 IAM or AM module.
5	Set the safety relay time delay beyond the time required to stop and disable the axis when running at full speed.
6	Drive Enable Input Checking must be selected when configuring Axis Properties in the Logix Designer application.

This example diagram shows 2094-xCxx-Mxx and 2094-xMxx drives (without safe torque-off) and 2094-ALxxS, 2094-BLxxS, and 2094-XL75S LIM modules wired with the Bulletin 2090 RBM module.

Figure 122 - RBM Wiring Example, Category 2 Configuration per ISO 13849-1

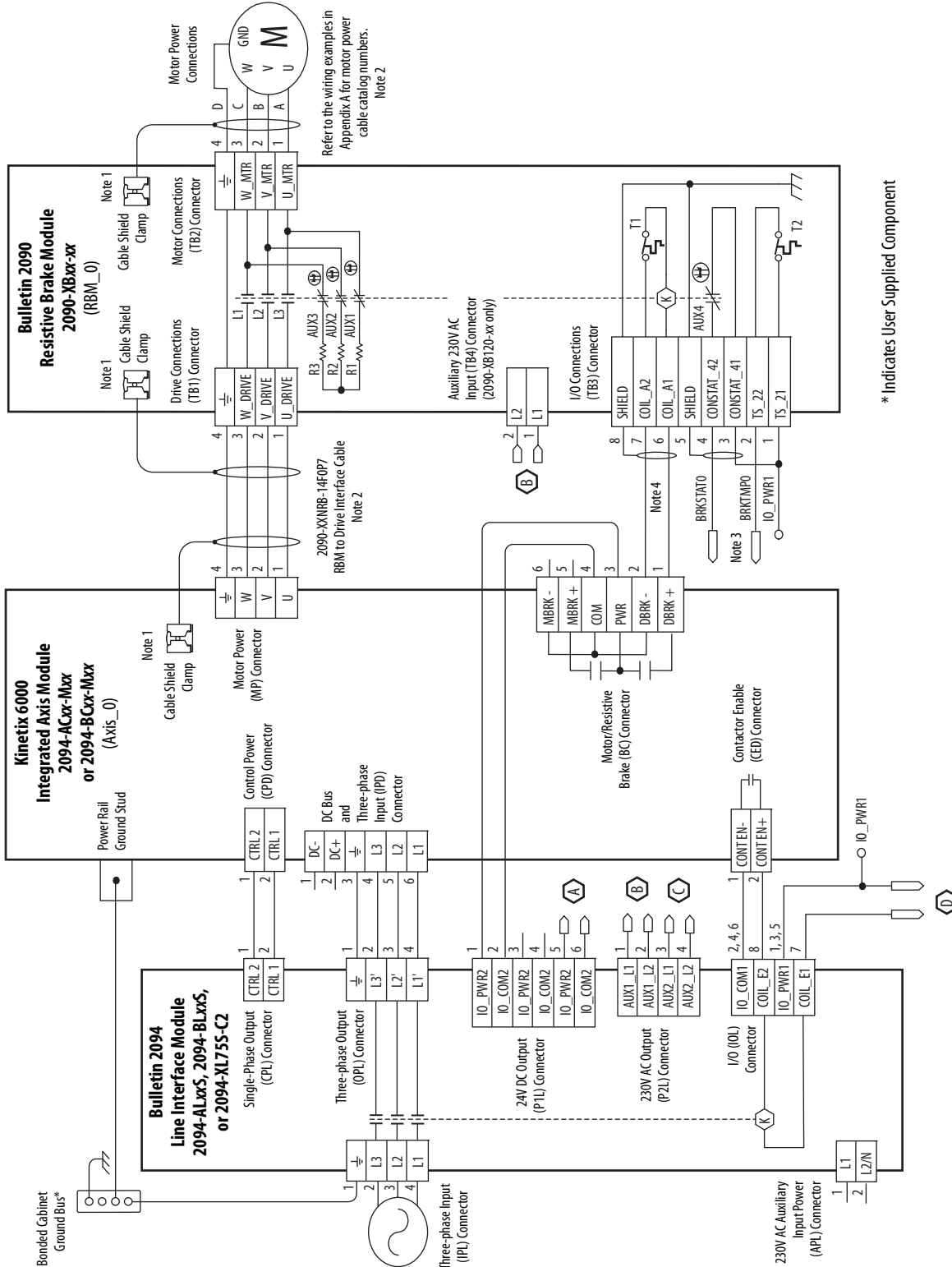

RBM Wiring Example, Category 2 Configuration per ISO 13849-1 (continued)

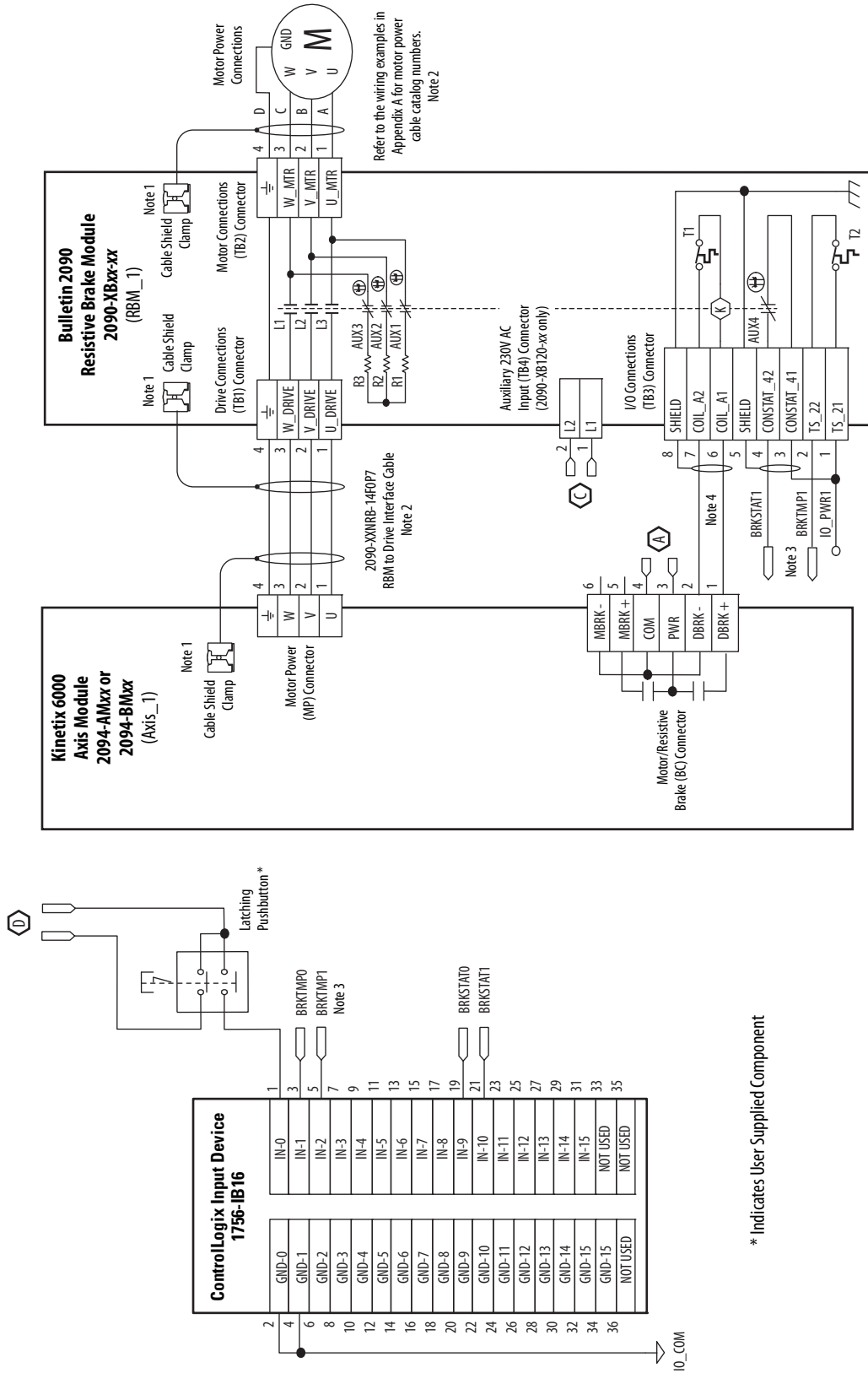

This example diagram shows 2094-xCxx-Mxx and 2094-xMxx drives (without safe torque-off) and 2094-AL09 and 2094-BL02 LIM modules wired with the Bulletin 2090 RBM module.

Figure 123 - RBM Wiring Example, Category 2 Configuration per ISO 13849-1

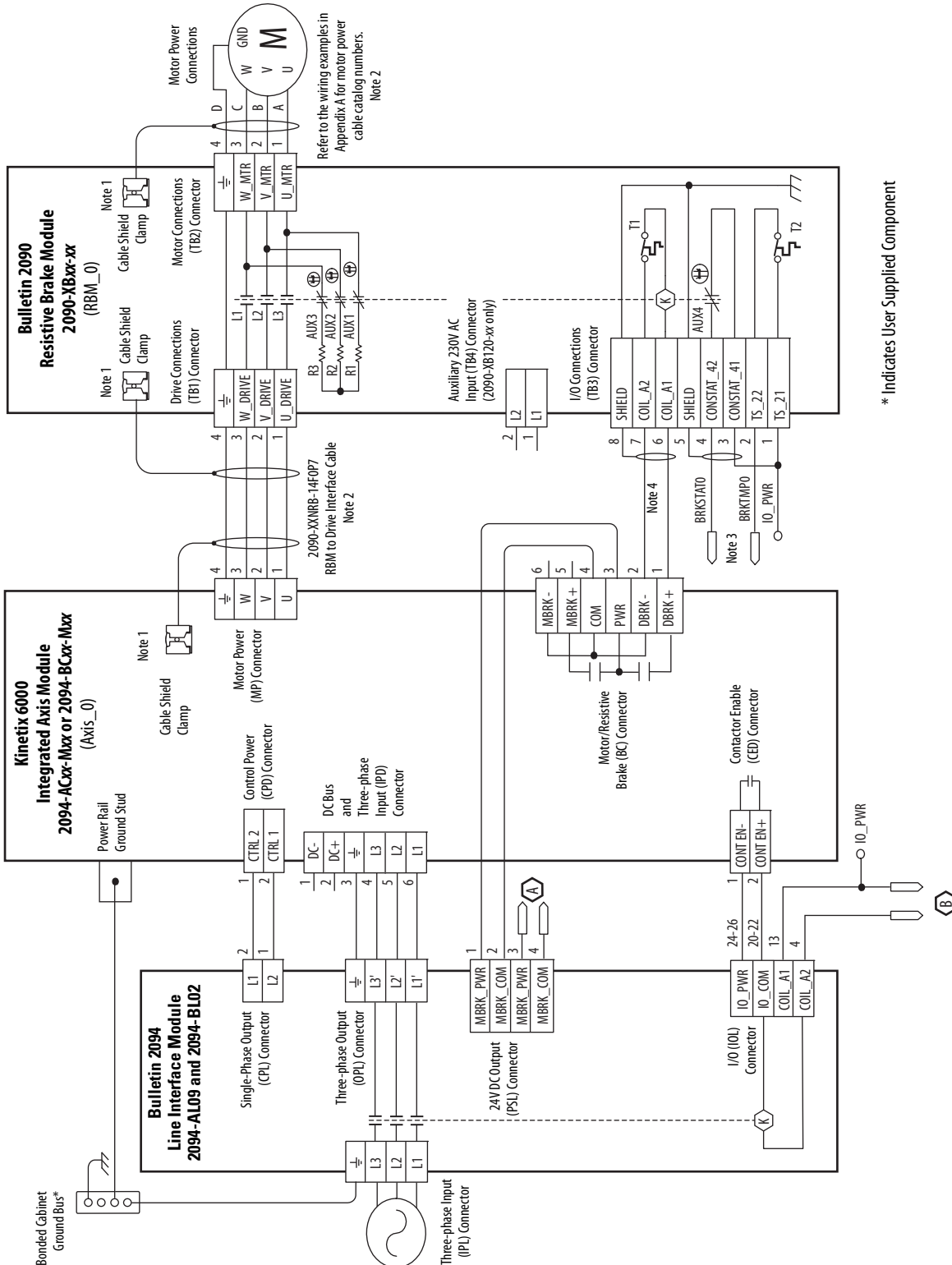

RBM Wiring Example, Category 2 Configuration per ISO 13849-1 (continued)

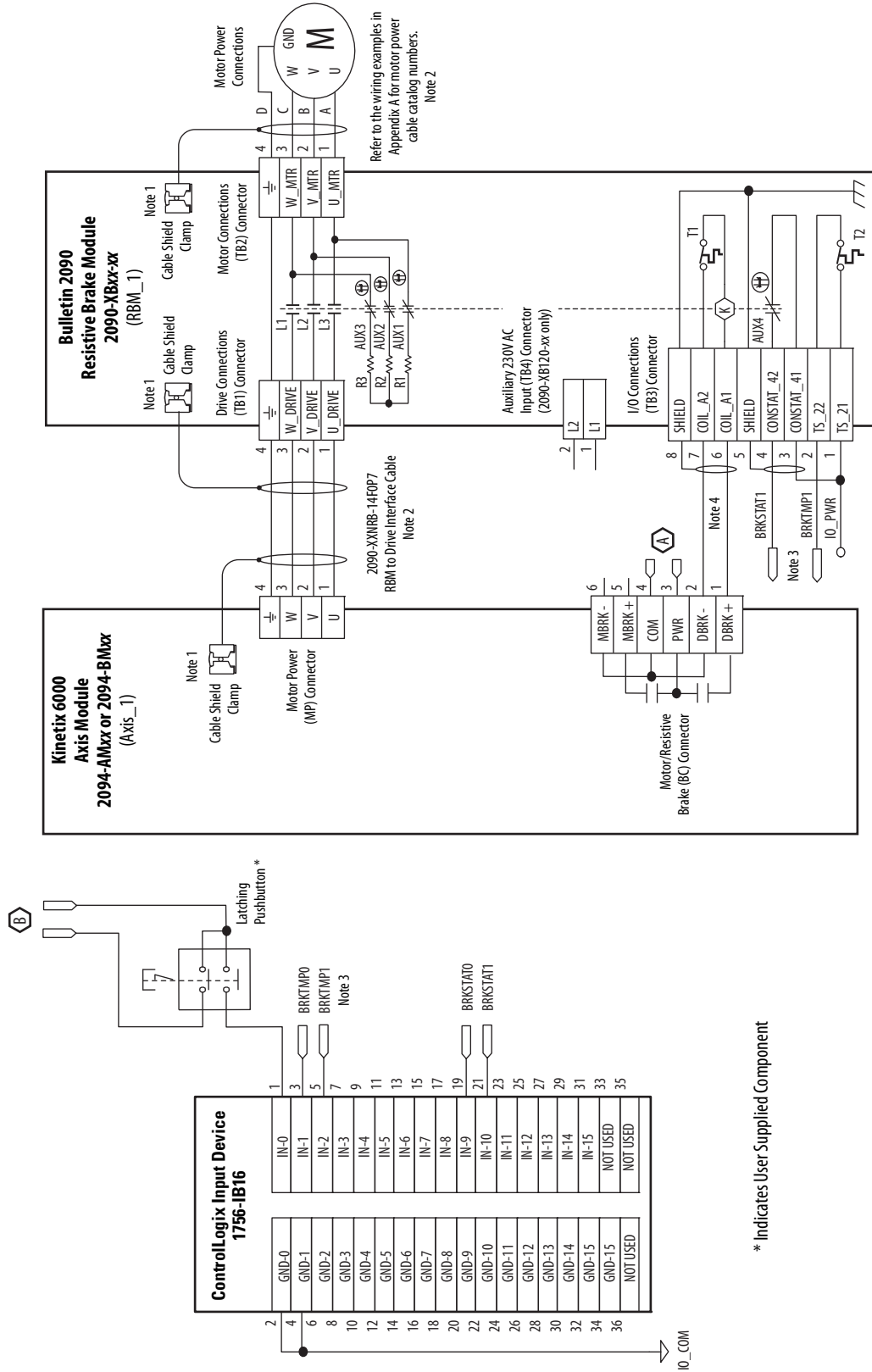

This example diagram shows 2094-xCxx-Mxx drives (without safe torque-off) and 2094-ALxxS, 2094-BLxxS, and 2094-XL75S LIM modules wired with the Bulletin 2090 RBM module. The example continues on [page 273](#).

Figure 124 - RBM Wiring Example, Category 3 Configuration per ISO 13849-1

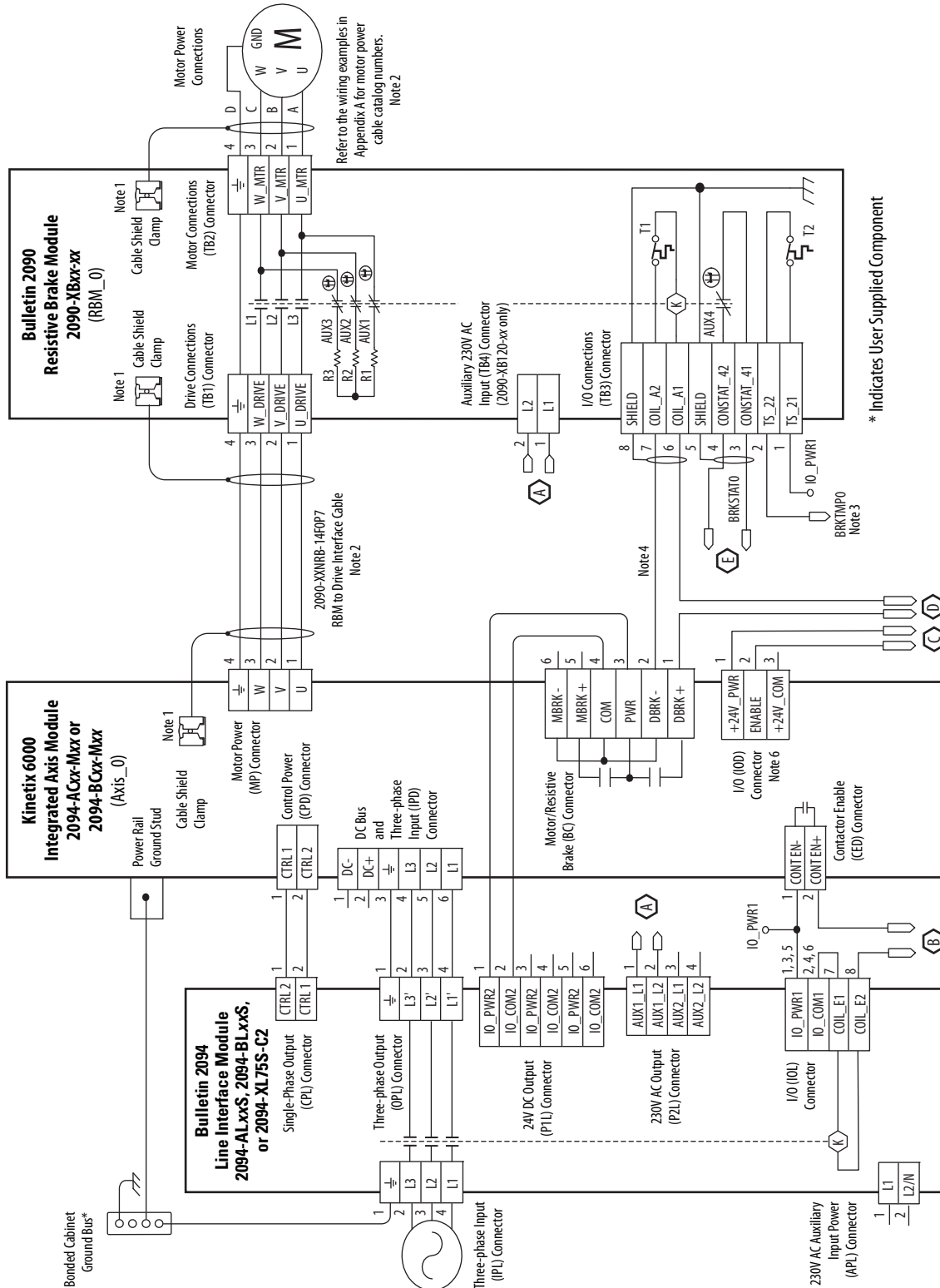

RBM Wiring Example, Category 3 Configuration per ISO 13849-1 (continued)

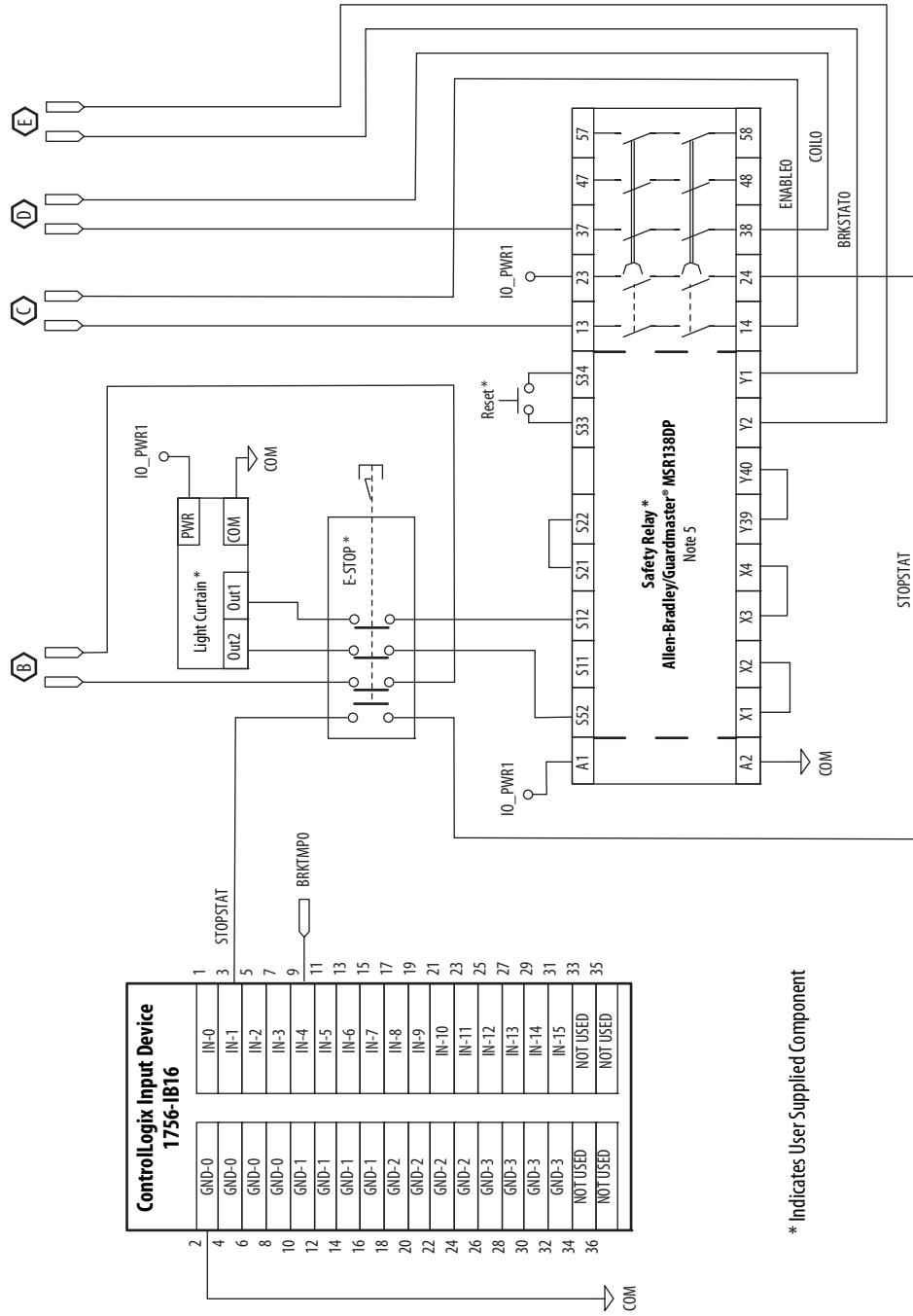

* Indicates User Supplied Component

This example diagram shows 2094-*x*C*xx*-*M**xx* drives (without safe torque-off) and 2094-AL09 and 2094-BL02 LIM modules wired with the Bulletin 2090 RBM module.

Figure 125 - RBM Wiring Example, Category 3 Configuration per ISO 13849-1

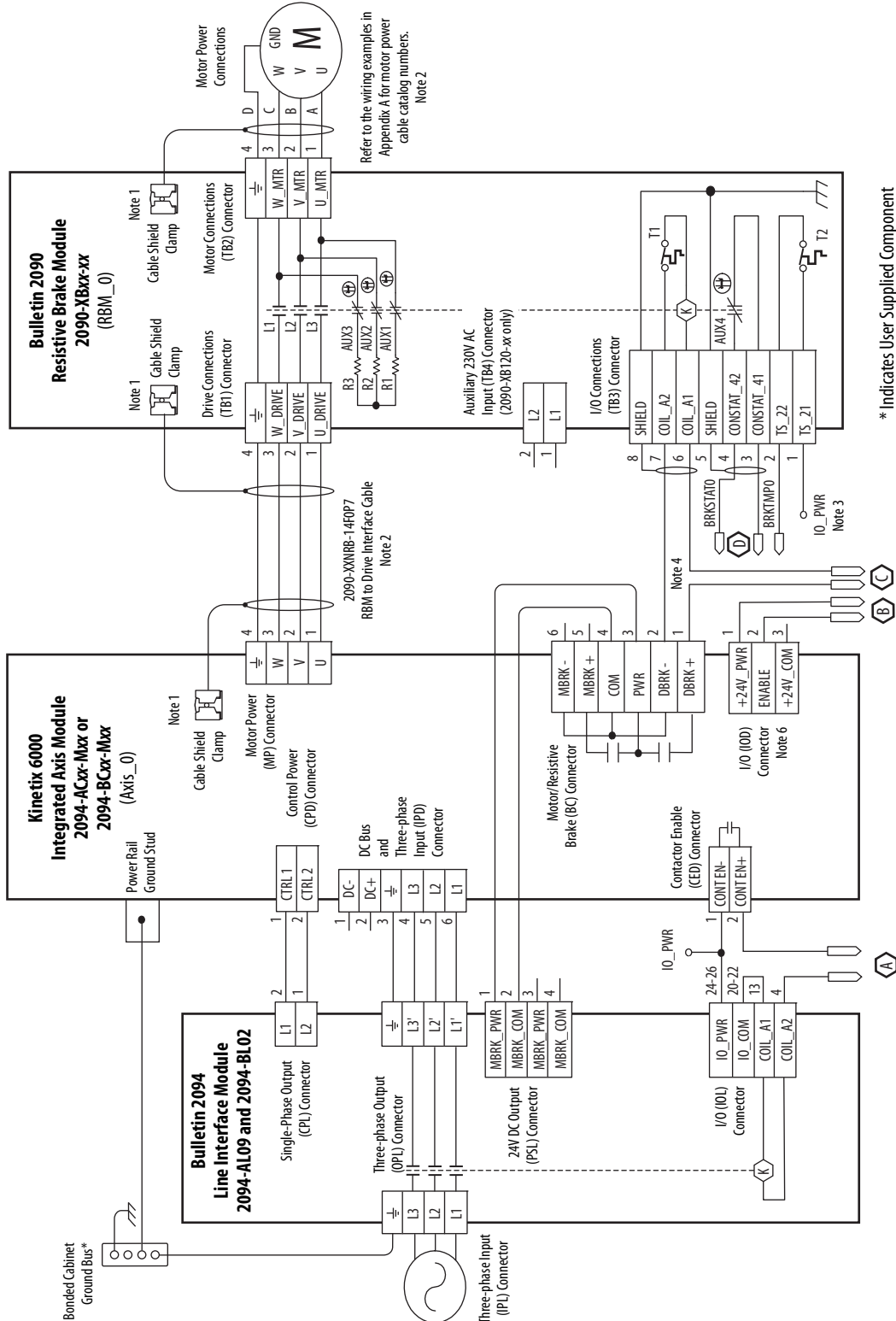

* Indicates User Supplied Component

RBM Wiring Example, Category 3 Configuration per ISO 13849-1 (continued)

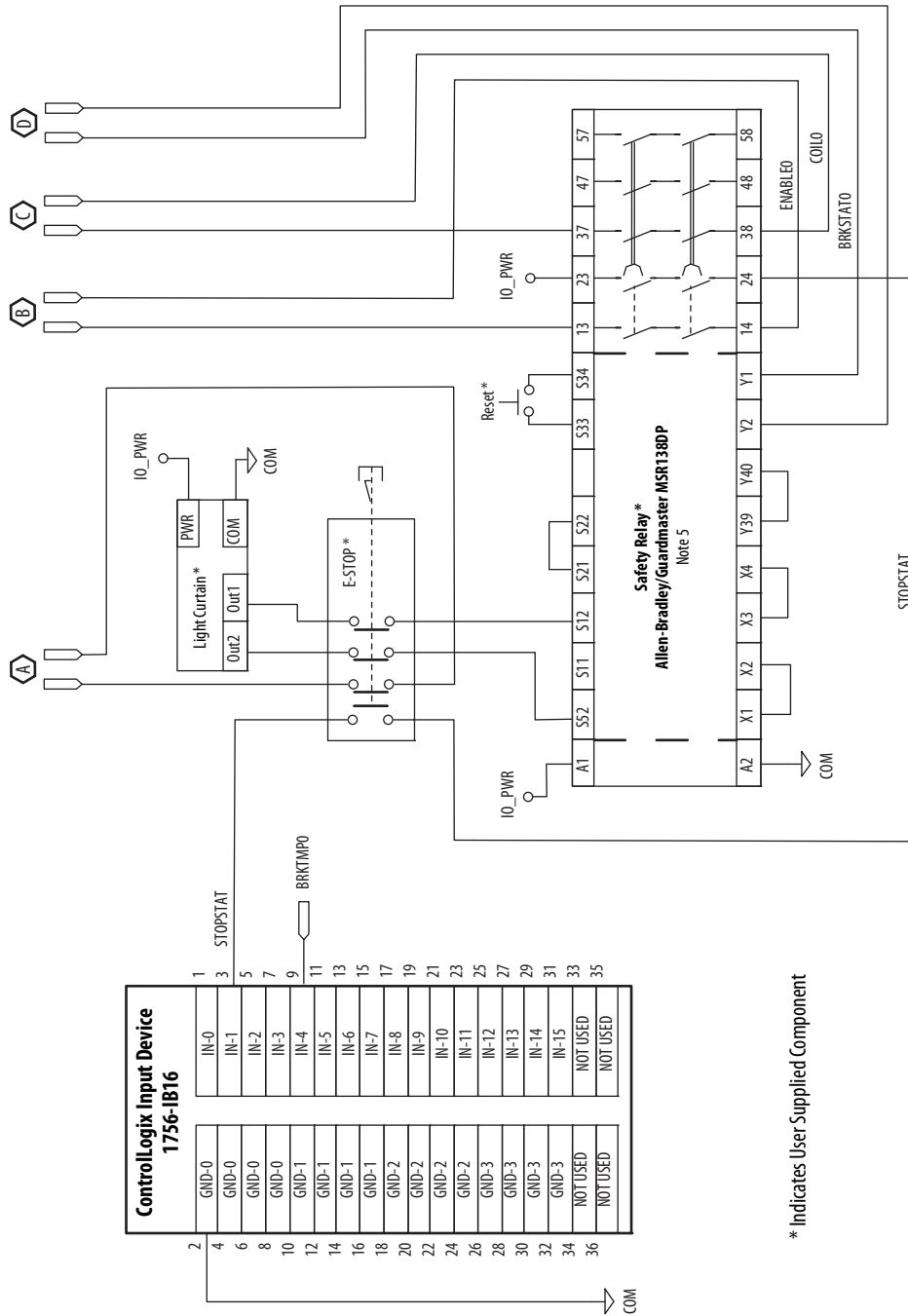

* Indicates User Supplied Component

Notes:

Numerics

1756-MxxSE 140
1768-M04SE 140
1784-PM16SE 140
2090-K6CK-D15F 115, 122, 123
2090-K6CK-D15M 115, 122, 123, 196
2090-K6CK-D15MF 109, 115, 122, 124, 203
2090-K6CK-D26M 115, 122, 124
2090-K6CK-KENDAT 63, 77, 115, 122, 123
2094 power rail 52
26-pin I/O connector 161

A

about this publication 11
AC line filters
 noise reduction 47
 selection 27
acceleration
 feedback 237
 reference 235
acronyms 11
actual position feedback 235
actuators
 LDAT 207
 MPAI 206
 MPAR 206
 MPAS 205
additional bus capacitance
 calculating 227
 example 228
additional resources 12
analog outputs 69
analog test points
 DAC0 161
 DAC1 161
applying power 153
atune fault 168
audience for this manual 11
aux fdbk noise fault 168
aux feedback AQB 168
aux feedback loss 168
auxiliary
 encoder error 166
 feedback
 encoders 80
 pinouts 64
 specifications 78

axis module

axis properties 149, 151
 catalog number 22
 configuring 134
 connector designators 59
 mounting 54
 removing from power rail 180
 replacing on power rail 181
 series change 15
 status indicators 170
 wiring requirements 96

axis unstable

B

backplane comm 168
bandwidth 158
 Kop 237
base node address 134
 example with double-wide modules 138
 example with IDM system 139
 example with two ControlLogix chassis 137
 example with two power rails 136
baud rate 135
bayonet connector 105
block diagrams
 converter 213
 inverter 212
 shunt module 214
blown fuse 165
bonding
 EMI (electromagnetic interference) 34
 examples 35
 high-frequency energy 36
 subpanels 36
braided strap 93
brake relay 71
building your own cables 82
bus
 overcurrent 168
 overvoltage 166
 regulator 147
 status indicator 154, 170
 undervoltage 166

C

cables
 building your own cables 82
 categories 45
 CE requirements 24
 fiber-optic cable length 128
 noise zones 37
 routing 26
 shield clamp 114
 shield, EMC 107, 108, 109
CAN init 169
capacitance values 227

- catalog number**
 - axis module 22
 - integrated axis module 22
 - IPIM module 22
 - shunt module 22
 - slot-filler module 22
 - CB1, CB2, CB3** 153
 - CE compliance** 24
 - changing parameters**
 - DriveExplorer 160
 - HIM 161
 - circuit breaker**
 - LIM 153
 - selection 28
 - clamp** 114
 - comm status indicator** 154, 170
 - common bus (refer to DC common bus)**
 - compatibility**
 - IDM system 23
 - network 23
 - compliant mechanical loads** 242
 - configuration** 236
 - configuring**
 - AM 134
 - axis properties 149
 - baud rate, IAM 135
 - delay times 151
 - drive modules 144
 - feedback only axis 146
 - IAM 134
 - optical power level 135
 - configuring sercos**
 - base node address 134
 - IDM system 133
 - sercos module 140, 142
 - connecting**
 - Ethernet cables 132
 - external shunt resistor 125
 - feedback 115
 - I/O 115
 - IPIM module 126
 - motor shield clamp 114
 - panel-mounted breakout kit 121
 - premolded feedback cables 120
 - resistive brake module 127
 - sercos cables 128
 - connector designators**
 - axis module 59
 - integrated axis module 59
 - connector locations**
 - axis module 59
 - integrated axis module 58
 - contactor enable relay** 70
 - control power**
 - input specifications 76
 - ControlFLASH**
 - firmware upgrade 215
 - software kit 216
 - troubleshooting 222
 - verify upgrade 223, 232
 - controller properties** 140
 - conventions used in this manual** 11
 - conversion tab** 150
 - converter** 213
 - CPLD FLT** 169
 - cycle time** 143
- D**
- DACO** 161
 - DAC1** 161
 - data rate** 143
 - data type** 145
 - date/time tab** 141
 - DC common bus**
 - capacitance values 227
 - common bus fit 169
 - configuring 147
 - follower IAM 20, 86
 - fuse requirements 87
 - interconnect diagram 191, 192, 193, 194
 - leader IAM 20, 86
 - pre-charge 20, 86, 226
 - setting the add bus cap parameter 229
 - total bus capacitance 20
 - typical installation 20
 - delay times** 151
 - digital**
 - I/O not working correctly 165
 - inputs 67
 - DIN-style connector** 105
 - dip switches** 143
 - disable drive** 175
 - download**
 - Motion Analyzer 13
 - program 152
 - drive**
 - compatibility 23
 - enable fault 167
 - overcurrent 165
 - overtemp 167, 168
 - status indicator 154, 170
 - tab 149
 - undervoltage 167
 - DriveExplorer**
 - software 160, 229
- E**
- earth ground** 93
 - EMC**
 - cable shield 107, 108, 109
 - motor ground termination 103
 - EMI (electromagnetic interference)**
 - bonding 34
 - enable time synchronization** 141
 - enclosure**
 - requirements 26
 - selection 30
 - encoder communication fault** 166
 - encoders** 80
 - erratic operation** 174

error codes 165
establishing communication 170
EtherNet/IP
 connecting cables 132
 PORT1 and PORT2 connectors 132
external shunt resistor 48
 wiring 125

F

fault action 176
 programmable 176
 tab 150
fault codes
 IDM system 164
feedback
 cables and pinouts 115
 cables, CE 24
 feedback only axis 146
 gain (Kof) 237
 motor feedback connector 59
 power supply 79
 tab 150
fiber-optic
 Rx and Tx connectors 128
 signals 68
fiber-optic cables
 drive-to-drive 130
 drive-to-IPIM 131
firmware upgrade 215
 verify upgrade 223, 232
follow
 error 166
follower
 IAM 20, 86
fuse selection 28

G

gains 237
ground
 fault 167
 jumper setting 87
grounded power configuration 83
grounding multiple subpanels 94

H

hardware
 enable input 155, 157
 overtravel 165
headers
 motion allowed jumper 60
HF bonding 34
high-frequency
 energy 36
 resonances 247
HIM 160

hookup
 fault 168
 tab 155
human interface module (HIM) 160

I

I/O
 connections 115
 I/O connector 161
 pinouts, AM 61
 pinouts, IAM 61
 specifications 67
IAM module
 mounting 54
IDM fault codes 164
IDM system
 compatibility 23
 configuring sercos 133
 firmware upgrade 215
 interconnect diagram 210
 system overview 19
IDN
 calculate value 252
 change values 249, 262
 load observer 235
 read value 250
 read/write messages 246
 write value 253
ifbk HW fault 167
illegal hall state 166
input
 connector pinouts, IAM 65
 gain (Kou) 237
 power source 154
input power wiring
 3-phase delta 84
 determining input power 83
 ground jumper setting 87
 grounded power configuration 83
 ungrounded power configuration 85
installing drive accessories
 AC line filters 47
 external shunt resistor 48
 low-profile connector kits 122
 motor brake 50
 RBM 50
 thermal switch 50
installing your drive 25
 bonding examples 35
 bonding subpanels 36
 cable categories 45
 circuit breakers 28
 clearance requirements 33
 enclosure selection 30
 fuse selection 28
 HF bonding 34
 line filter 27
 noise zones 37
 system mounting requirements 26
 transformer 27
integral bandwidth (Koi) 237

integrated axis module

- axis properties 149, 151
- catalog number 22
- configuring 134
- connector designators 59
- connector locations 58
- interconnect diagram 187, 188, 190, 191, 192, 193, 194
- removing from power rail 180
- replacing on power rail 181
- series change 15
- status indicators 170
- wiring BC connector 111
- wiring CED connector 101
- wiring CPD connector 98
- wiring IPD connector 99
- wiring MP connector 103
- wiring requirements 95, 96
- wiring STO connector 102

interconnect diagrams

- 2094 with 1326AB 203
- 2094 with F-Series motor 204
- 2094 with LDAT 207
- 2094 with LDC-Series 208, 209
- 2094 with LDL-Series 208, 209
- 2094 with MPAI 206
- 2094 with MPAR 206
- 2094 with MPAS 205
- 2094 with MPL 196
- 2094 with MPL motor 197
- 2094 with MPL/MPM 200
- 2094 with MPL/MPM/MPF 199
- 2094 with MPL/MPS 198
- 2094 with RDD-Series 201
- 2094 with TL-Series motor 202
- IDM system 210
- notes 186, 266
- power, DC common bus 191, 192, 193, 194
- power, IAM with LIM 187, 188
- power, IAM without LIM 190
- RBM 266
- shunt module
 - 2094 195
 - passive 195

interpreting status indicators 164**inverter 212****IPIM module**

- catalog number 22
- compatibility 23
- fault 169
- mounting 54
- removing from power rail 181
- wiring 126

IPM fault 165**ISO 13849-1 268****K****Kinetix 6000M system**

- compatibility 23

L**leader IAM 20, 86****line filter selection 27****line interface module**

- circuit breakers 153
- interconnect diagram 187, 188, 190
- three-phase power 154

linear motors

- LDC-Series 208, 209
- LDL-Series 208, 209

load inertia ratio 235**load observer**

- acceleration
 - feedback 237
 - reference 235
- actual position feedback 235
- auto-tuning 244
- bandwidth (Kop) 237
- configuration 236
- feedback gain (Kof) 237
- gains 237
 - auto-tune 241
 - compliant mechanical loads 242
 - high-frequency resonances 247
 - manual tuning 244
 - out-of-box 239
 - rigid mechanical loads 242
- IDN read/write messages 246
- input gain (Kou) 237
- integral bandwidth (Koi) 237
- load inertia ratio 235
- mechanical load 235
- no auto-tuning 244
- torque estimate 235
- velocity
 - estimate 236
 - feedback 236

logic power status indicator 153**Logix Designer application 12, 140, 160, 216, 229****low profile connector kits**

- wiring 122

M**manual tuning 244****mechanical load 235****memory init 168****module**

- mismatch 169
- mounting order 52
- properties
 - drive modules 144
 - sercos module 142

monitor system variables 161**Motion Analyzer software**

- download 13

motion group properties 148**motion-allowed jumper 60, 102**

motor

- encoder error 166
- feedback loss 165
- jumps when first enabled 165
- motor and feedback tab 150
- overtemp 165

motors

- acceleration or deceleration anomalies 173
- brake 50
- cable length 24, 26
- feedback pinouts 62, 117
- feedback specifications 78
- ground termination 103
- interconnect diagram
 - 1326AB 203
 - F-Series 204
 - MPL 196, 197
 - MPL/MPM 200
 - MPL/MPM/MPF 199
 - MPL/MPS 198
 - RDD-Series 201
 - TL-Series 202
- MPL connectors
 - bayonet 105
 - DIN-style 105
- overheating 174
- power and brake pinouts 66
- power wiring
 - 3-phase and brake 108
 - 3-phase only 107
 - 3-phase, brake, thermal switch 109
 - TL-Series 104
- shield clamp wiring 114
- testing 155
- tuning 155
- velocity 173

mounting brackets 51**mounting your drive 54**

- 2094 power rail 52
- axis module 54
- IAM module 54
- IPIM module 54
- module mounting order 52
- mounting brackets 51
- shunt module 54
- slot-filler module 54

MPL connectors

- bayonet 105
- DIN-style 105

mtr fdbk noise fault 168**N****network compatibility 23****node address 145****noise**

- abnormal 174
- feedback 174
- reduction 47
- zones 37

NV mem init 168**O****objects init 168****optical power level 135****overspeed fault 166****P****panel**

- mounted breakout kit 121
- requirements 26

parameters

- drive
 - IDN 249, 262
 - peak enhancement 262
 - system variables 160
- load observer 235
- peak enhancement 256

peak enhancement

- definition of terms 74
- enable peak enhancement 255
- example 257
- example calculation 260
- inverter overload curve 75
- load duty cycle 74
- peak current ratings 73
- peak overload support 73
- software/firmware 73
- specifications 73

pinouts

- auxiliary feedback connector 64
- I/O connector
 - IAM/AM 61
- input connector, IAM 65
- motor and brake connector 66
- motor feedback connector 62, 117
- safe torque-off connector
 - IAM/AM 60

planning your installation 25**PORT 1 status indicator 154****PORT 2 status indicator 154****power**

- cables, CE 24
- cycling 72
- dissipation 32
- indicator not on 165
- phase loss 167

power rail

- connecting braided strap 93
- removing 182
- replacing 183

power supply, feedback 79**power up 153****pre-charge 20, 86, 226**

- fault 167
- timeout flt 169

premolded feedback cables 120**publications, related 12****R****RBM 50**

related publications 12
relay output 211
removing modules from power rail 180
replacing modules on power rail 181
resistive brake module
 interconnect diagrams 266
 wiring 127
rigid mechanical loads 242
routing power and signal wiring 82
RSLinux software 216
RSLogix 5000 software 216, 229

S

safe torque-off
 HW fault 167
 motion-allowed jumper 60, 102
 pinouts, AM 60
 pinouts, IAM 60
 wiring 102
safety lock status indicator 154
SCANport
 comm 168
SCANport/DPI adapter 160, 229
selection
 AC line filters 27
self sense fault 167
sercos
 connecting cables 128
 connections 68
 init 169
 module 140
 module properties 142
 ring fault 167
 same addr 167
series change 15
 peak enhancement specifications 73
setting the add bus cap parameter 229
seven-segment status indicator 154
shield clamp 114
shunt module 214
 bus status indicator 172
 catalog number 22
 fault 169
 interconnect diagram
 2094 195
 passive 195
 mounting 54
 removing from power rail 181
 shunt fault status indicator 172
 temperature status indicator 172
 time out 168
 troubleshooting 171
 wiring requirements 96
shutdown 175
slot-filler module
 catalog number 22
 mounting 54
 removing from power rail 181

software
 DriveExplorer 160, 229
 overtravel 166
 Studio 5000 Environment 12
specifications
 analog outputs 69
 auxiliary feedback encoders 80
 brake relay 71
 contactor enable relay 70
 control power input 76
 digital inputs 67
 feedback
 motor and auxiliary 78
 power supply 79
 peak enhancement 73
 power
 cycling 72
 dissipation 32
 sercos connections 68
status indicators 154, 164, 170
 bus status 170
 comm status 170
 drive status 170
 logic power 153
 sercos interface module 154
 seven-segment 154
status only 175
stop motion 175
Studio 5000 Environment 12
surge suppression 112
switches
 base node address 134
 baud rate 135
 optical power level 135
system
 components 16
 ground 93
 mounting requirements 26
system block diagrams
 converter 213
 inverter 212
 shunt module 214
system overview
 DC common bus 20
 sercos 21
 with LIM 17
 without LIM 18

T

task init 168
testing axes
 hookup tab 155
thermal switch 50
torque estimate 235
total bus capacitance 20
 calculating 226
 example 228
training 11
transformer
 sizing 27
transmit power level 143

troubleshooting

- bus status indicator 170
- comm status indicator 170
- ControlFLASH 222
- disable drive 175
- drive status indicator 170
- error codes 165
- fault action 176
- general
 - atune fault 168
 - aux fdbk noise fault 168
 - aux feedback AQB 168
 - aux feedback loss 168
 - auxiliary encoder error 166
 - backplane comm 168
 - blown fuse 165
 - bus overcurrent 168
 - bus overvoltage 166
 - bus undervoltage 166
 - CAN init 169
 - common bus flt 169
 - CPLD FLT 169
 - digital I/O not working correctly 165
 - drive enable fault 167
 - drive overcurrent 165
 - drive overtemp 167, 168
 - drive undervoltage 167
 - encoder communication fault 166
 - follow error 166
 - ground fault 167
 - hardware overtravel 165
 - hookup fault 168
 - lfbk HW fault 167
 - illegal hall state 166
 - IPIM module flt 169
 - IPM fault 165
 - memory init 168
 - module mismatch 169
 - motor encoder error 166
 - motor feedback loss 165
 - motor jumps when first enabled 165
 - motor overtemp 165
 - mtr fdbk noise fault 168
 - NV mem init 168
 - objects init 168
 - overspeed fault 166
 - power indicator not on 165
 - power phase loss 167
 - pre-charge fault 167
 - pre-charge timeout flt 169
 - safe torque-off HW fault 167
 - SCANport comm 168
 - self sense fault 167
 - sercos init 169
 - sercos ring fault 167
 - sercos same addr 167
 - shunt module fault 169
 - shunt time out 168
 - software overtravel 166
 - task init 168
 - unknown axis 167
- general system anomalies 173
 - abnormal noise 174
 - axis unstable 173
 - erratic operation 174
 - feedback noise 174

- motor acceleration or deceleration 173
- motor overheating 174
- motor velocity 173
 - no rotation 174
- Logix/drive fault behavior 175
- programmable fault action 176
- safety precautions 163
- shunt module 171
 - bus status indicator 172
 - shunt fault status indicator 172
 - temperature status indicator 172
- shutdown 175
- status only 175
- stop motion 175

tuning axes

- bandwidth 158
- tune tab 157

typical installation

- DC common bus 20
- IDM system 19
- sercos 21
- with LIM 17
- without LIM 18

U**ungrounded power configuration** 85**units tab** 150**unknown axis** 167**using analog test points** 161**V****velocity**

- estimate 236
- feedback 236

W**wiring**

- building your own cables 82
- earth ground 93
- Ethernet cables 132
- external shunt resistor 125
- ground jumper setting 87
- grounded power configuration 83
- I/O connections 115
- IAM
 - BC connector 111
 - CE connector 101
 - CPD connector 98
 - IPD connector 99
 - MP connector 103
 - STO connector 102
- input power type 83
- IPIM module 126
- low profile connectors 122
- motor cable shield clamp 114
- motor power 104, 107, 108, 109
- requirements 81
 - IAM 95
 - IAM/AM 96

shunt module 96
resistive brake module 127
routing power and signal wiring 82
safe torque-off feature 102
sercos fiber optic cables 128
ungrounded power configuration 85
wiring guidelines 97

Rockwell Automation Support

Rockwell Automation provides technical information on the Web to assist you in using its products.

At <http://www.rockwellautomation.com/support>, you can find technical manuals, technical and application notes, sample code and links to software service packs, and a MySupport feature that you can customize to make the best use of these tools. You can also visit our Knowledgebase at <http://www.rockwellautomation.com/knowledgebase> for FAQs, technical information, support chat and forums, software updates, and to sign up for product notification updates.

For an additional level of technical phone support for installation, configuration, and troubleshooting, we offer TechConnectSM support programs. For more information, contact your local distributor or Rockwell Automation representative, or visit <http://www.rockwellautomation.com/support/>.

Installation Assistance

If you experience a problem within the first 24 hours of installation, review the information that is contained in this manual. You can contact Customer Support for initial help in getting your product up and running.

United States or Canada	1.440.646.3434
Outside United States or Canada	Use the Worldwide Locator at http://www.rockwellautomation.com/rockwellautomation/support/overview.page , or contact your local Rockwell Automation representative.

New Product Satisfaction Return

Rockwell Automation tests all of its products to help ensure that they are fully operational when shipped from the manufacturing facility. However, if your product is not functioning and needs to be returned, follow these procedures.

United States	Contact your distributor. You must provide a Customer Support case number (call the phone number above to obtain one) to your distributor to complete the return process.
Outside United States	Please contact your local Rockwell Automation representative for the return procedure.

Documentation Feedback

Your comments will help us serve your documentation needs better. If you have any suggestions on how to improve this document, complete this form, publication [RA-DU002](#), available at <http://www.rockwellautomation.com/literature/>.

www.rockwellautomation.com

Power, Control and Information Solutions Headquarters

Americas: Rockwell Automation, 1201 South Second Street, Milwaukee, WI 53204-2496 USA, Tel: (1) 414.382.2000, Fax: (1) 414.382.4444

Europe/Middle East/Africa: Rockwell Automation NV, Pegasus Park, De Kleetlaan 12a, 1831 Diegem, Belgium, Tel: (32) 2 663 0600, Fax: (32) 2 663 0640

Asia Pacific: Rockwell Automation, Level 14, Core F, Cyberport 3, 100 Cyberport Road, Hong Kong, Tel: (852) 2887 4788, Fax: (852) 2508 1846

Publication 2094-UM001H-EN-P - June 2013

Supersedes Publication 2094-UM001G-EN-P - May 2012

Copyright © 2013 Rockwell Automation, Inc. All rights reserved. Printed in the U.S.A.