

**Why Omron?**

Omron quality is recognized industry-wide. We perform 100% quality inspection and testing procedures at every stage of manufacturing — your assurance of satisfaction.

**Your automation solution 24 hours a day.**

Get Omron's *SmartFactory* advantage by utilizing our application engineering know-how, extensive training, and 24-hour technical support. Through our commitment to flexible manufacturing, Omron has become a leader in the manufacture of Operator Interfaces, Digital Panel Meters, Digital Displays, Counters, Timers, Sensors, PLCs, Process and Temperature Controllers, and other control devices. To obtain up-to-date technical specifications for all Omron products 24 hours a day, 7 days a week from your phone or fax machine, call our *ControlFax* at 847.843.1963.

**Worldwide sales and support network.**

You'll find over 200 stocking distributors and local sales offices throughout North America. With branch offices worldwide, Omron provides replacement components, service and multi-lingual documentation virtually anywhere in the world.

**SECTION PAGE**

Selection Guide 2

Applications 4

Software 7

Operator Interface Terminals



NT11S 11



NT20S 15



NT30/30C 19



NT600S 23



NT620S/620C 27

Communications 30



MODEL	NT11S	NT20S	NT30	NT30C
<b>DISPLAY</b>				
Size	4 line x 20 character	5" diagonal	5.7" diagonal	5.7" diagonal
Type	Backlit LCD	Backlit STN LCD	Bicolor backlit STN LCD	8-color backlit STN LCD
Resolution	160 x 64 pixels	256 x 128 pixels	320 x 240 pixels	320 x 240 pixels
Interface	Alphanumeric	Touch screen	Touch screen	Touch screen
Touch cells	—	72 per screen	192 per screen	192 per screen
<b>FEATURES</b>				
	Large characters	Slim profile	Bicolor display	8-color display
	Contrast control	Easy to configure screens	Full graphic capabilities	Full graphic capabilities
	Password protect screens	Replaceable backlight LCD white mode option for better viewing angle	Replaceable backlight	Replaceable backlight
<b>MEMORY</b>				
Type	Flash EPROM	Flash EPROM	Flash EPROM	Flash EPROM
Size	32 K	96 K	512 K	512 K
Max. # of screens	250 screens	500 screens	2000 screens	2000 screens
<b>GRAPHIC CAPABILITIES</b>				
Freeform drawing		■	■	■
Bitmap			■	■
Tiling			■	■
Bar graph	■	■	■	■
Line trending			■	■
Thumbwheel switch		■	■	■
Text and numeric	■	■	■	■
Real-Time Clock			■	■
Printer Port	■		■	■
Communication	Host Link / NT Link	Host Link / NT Link (1:1/1:N) / C200H Interface	Host Link / NT Link	Host Link / NT Link
Overall Dimensions	218 <sub>W</sub> x 113 <sub>H</sub> x 38.2 <sub>D</sub> mm 8.58 <sub>W</sub> x 4.45 <sub>H</sub> x 1.50 <sub>D</sub> in	190 <sub>W</sub> x 110 <sub>H</sub> x 58 <sub>D</sub> mm 7.48 <sub>W</sub> x 4.33 <sub>H</sub> x 2.28 <sub>D</sub> in	195 <sub>W</sub> x 142 <sub>H</sub> x 55.6 <sub>D</sub> mm 7.68 <sub>W</sub> x 5.59 <sub>H</sub> x 2.19 <sub>D</sub> in	195 <sub>W</sub> x 142 <sub>H</sub> x 55.6 <sub>D</sub> mm 7.68 <sub>W</sub> x 5.59 <sub>H</sub> x 2.19 <sub>D</sub> in
<b>ENVIRONMENTAL</b>				
Ratings	NEMA 4	NEMA 4	NEMA 4	NEMA 4
Approvals	UL / CSA / CE	UL / CSA / CE	UL / CSA / CE	UL / CSA / CE
Accessories	—	Backlight Chemical resistant cover Protective sheet C200H Interface	Backlight Chemical resistant cover Protective sheet B7A Interface	Backlight Chemical resistant cover Protective sheet B7A Interface



MODEL	NT600S (LCD)	NT600S (EL)	NT620S	NT620C
<b>DISPLAY</b>				
Size	9" diagonal	9" diagonal	9" diagonal	9.7" diagonal
Type	Backlit STN LCD	Electroluminescent	Electroluminescent	8-color backlit STN LCD
Resolution	640 x 400 pixels	640 x 400 pixels	640 x 400 pixels	640 x 480 pixels
Interface	Touch screen	Touch screen	Touch screen	Touch screen
Touch cells	128 per screen	128 per screen	512 per screen	768 per screen
<b>FEATURES</b>				
	Large screen	Clear EL display	Clear EL display	8-color display
	Slim profile	Extra-wide viewing angle	Full graphic capabilities	Full graphic capabilities
	Replaceable backlight	Slim profile	Extra-wide viewing angle	Replaceable backlight
<b>MEMORY</b>				
Type	Flash EPROM	Flash EPROM	Flash EPROM	Flash EPROM
Size	128 K	128 K	512 K	1 MB
Max. # of screens	500 screens	500 screens	2000 screens	2000 screens
<b>GRAPHIC CAPABILITIES</b>				
Freeform drawing	■	■	■	■
Bitmap			■	■
Tiling			■	■
Bar graph	■	■	■	■
Line trending			■	■
Thumbwheel switch	■	■	■	■
Text and numeric	■	■	■	■
Real-Time Clock			■	■
Printer Port			■	■
Communication	Host Link / NT Link (1:1/1:N) / C200H Interface	Host Link / NT Link (1:1/1:N) / C200H Interface	Host Link / NT Link (1:1/1:N) / Memory Link	Host Link / NT Link (1:1/1:N) / Memory Link
Overall Dimensions	275 <sub>W</sub> x 192 <sub>H</sub> x 71 <sub>D</sub> mm 10.83 <sub>W</sub> x 7.56 <sub>H</sub> x 2.80 <sub>D</sub> in	275 <sub>W</sub> x 192 <sub>H</sub> x 71 <sub>D</sub> mm 10.83 <sub>W</sub> x 7.56 <sub>H</sub> x 2.80 <sub>D</sub> in	275 <sub>W</sub> x 192 <sub>H</sub> x 71 <sub>D</sub> mm 10.83 <sub>W</sub> x 7.56 <sub>H</sub> x 2.80 <sub>D</sub> in	275 <sub>W</sub> x 196 <sub>H</sub> x 76.8 <sub>D</sub> mm 10.83 <sub>W</sub> x 7.72 <sub>H</sub> x 3.02 <sub>D</sub> in
<b>ENVIRONMENTAL</b>				
Ratings	NEMA 4	NEMA 4	NEMA 4	NEMA 4
Approvals	UL / CSA / CE	UL / CSA / CE	UL / CSA / CE	UL / CSA / CE
<b>Accessories</b>				
	Backlight	Chemical resistant cover	Chemical resistant cover	Backlight
	Chemical resistant cover	Protective sheet	Protective sheet	Chemical resistant cover
	Protective sheet	C200H Interface		Protective sheet
	C200H Interface			

Process Monitoring

The graphic capabilities of the NT Series Terminals make process illustration simple. On this display screen, bar graphs are used to simulate tank levels, and lamps show on/off value or motor status. Combine these graphic images with the variety of touch switches and error messages available and you have a detailed process monitoring application.

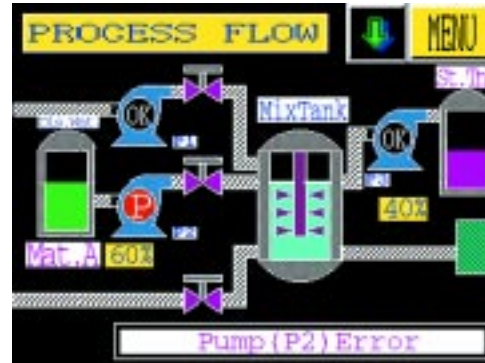

Temperature Monitoring

With the NT Series Terminals, you can easily consolidate many separate gauges, thumbwheels, and panel meters into one convenient control center. Here, temperature values are monitored on the display using graphs and thumbwheel switches. You can set high/low limits on the thumbwheel switches and use them to quickly change temperature set values.



Production Monitoring

Track real production levels against target projections with the NT Series Terminals. Monitor multiple lines from a single point and change target values with a quick touch of the screen.



Production Monitoring



Production or assembly line operations can be monitored with a quick glance using the graphic capabilities of the NT Series Terminals. In this example screen, the graphic representation provides an assembly line overview. Lamps simulate motion and can also be used to show errors, quickly alerting your operators to problems in production. And error messages provide the information necessary to fix these problems fast.

Timers, Counters, Thumbwheels

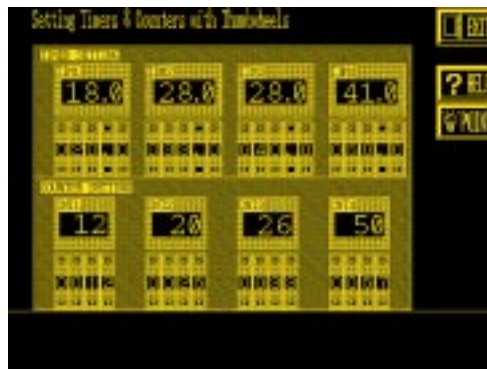

Replacing or adding timers, counters, and thumbwheel switches has never been easier. With the NT Series Terminals you get a complete selection on a single screen. And because there's no costly hard-wire redesign considerations, you have the flexibility to choose from a variety of thumbwheel switches in two, four, or eight digits and you can set high/low limits for each.

Pop-up Window Function



A pop-up window function is available on the NT30/30C and NT620S/620C terminals. Save on valuable screen space while you input numbers or characters to change set points, production targets, lot codes, or product types. Pop-up windows can also be used for error and help messages which means you won't have to switch off your main screen for monitoring.

Pushbuttons, Lamps,  
Switches

These display screens show how the NT Series Terminals replace hard-wired pilot lights and pushbuttons with realistic graphic icons. Saving on valuable panel space and wiring expense, additional pushbuttons and pilot lights can be added easily — just change your program. You won't need to endure the costly redesign of hard-wire devices. A variety of pushbuttons including: standard, momentary, and set/reset are available. And with the NT30/30C and NT620S/620C terminals, you can use bitmap images to create ultra-realistic switches and lamps.

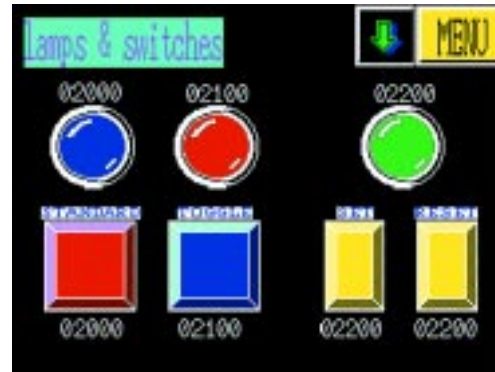

Custom Graphics

With all the graphic possibilities of the NT Series Terminals, you can custom design dynamic application screens for your plant operation. Freeform drawing capabilities allow you to accurately illustrate each stage in the production process. And bitmap images can be used with the NT30/30C and NT620S/NT620C models, allowing you to include realistic graphic representations of anything from lamps and touch switches to company logos. Here, process status is monitored using bar graphs to track actual production values to target projections.

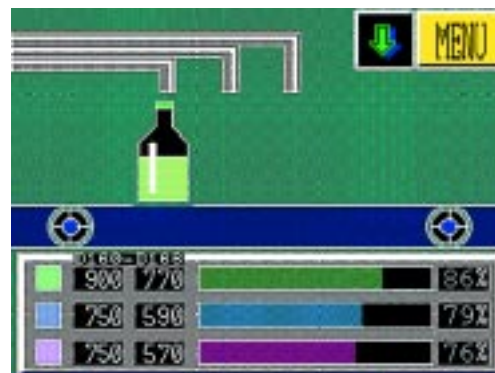

FAST, EASY AND POWERFUL



Design, edit and modify your operator interface screens quickly and easily with

Omron's new NT Series Support Tool display development software. This powerful, Windows®-based package works with all NT-S Series Omron operator interfaces and features user-friendly icons, menus and built-in objects to help you develop dynamic, functional and attractive screens. NT Series Support Tool was designed specifically for use with the Windows 95' operating system to let you take full advantage of its 32-bit architecture, multi-tasking and user-friendly features.

With drawing tools similar to those found on commercial drawing packages, NT Series Support Tool is perfect for the experienced designer as well as beginners. Freehand drawing capabilities and bitmap import, along with powerful graphic tools, let you quickly and accurately illustrate your production process or machine. With NT Series Support Tool, you get the most out of your Omron operator interface investment and increase your production or machine efficiency.

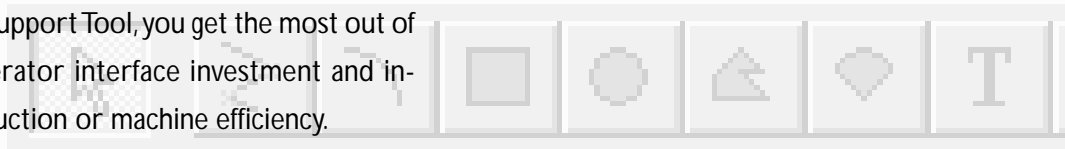

**FEATURES:**

- Cut, copy, paste, group, ungroup
- Batch change of allocated bits and words
- Import bitmaps
- 10 levels of undo/redo
- NT Series Support Tool can be used with the following Omron touchscreen models:  
 NT11S-SF121(B)  
 NT20S-ST12\*(B)-V1 or -EV3  
 NT600S-ST121 or ST211-V1 or -EV3  
 NT30-ST131(B)-E  
 NT30C-ST141(B)-E  
 NT620S-ST211(B)-E  
 NT620C-ST141(B)-E

**SYSTEM REQUIREMENTS**

- IBM PC compatible with 486 or higher processor, running Microsoft Windows 95 (A Pentium processor is recommended for optimal performance)
- At least 8 MB of RAM but 16MB is recommended
- 10MB of available hard disk space
- Microsoft Windows 95  
 Note: Will not work with Windows 3.1 or Windows NT

**ORDERING INFORMATION**

<b>Software</b>	
NT Series Support Tool	NT-ZJ3AT1-EV1
<b>Cables</b>	
Programming Cable 9-9 pin	C200H-CN229-EU
Programming Cable 9-25 pin	C200H-CN220-EU

Some of NT Series Support Tool's powerful features:

**Drawing Tool Bar**

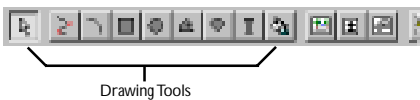

With NT Series Support Tool all your drawing tools are up front.

Now you can quickly and easily create dynamic applications for your operator interface. And because NT Series Support Tool adheres to Windows 95 standards, it comes with bubble "Help" to assist you in creating your screens.

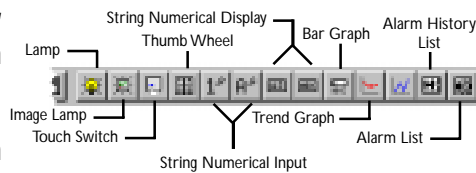

**Multiple Windows**

Work with multiple screens concurrently. Save valuable drawing, editing, and debug time with NT Series Support Tool by working on multiple screens at the same time. Simply copy and paste elements from one screen to another.



**Symbol Manager**

Display components can be created and registered. Over time you can build a library of bitmaps or other objects that can be registered in NT Series Support Tool's Symbol Manager.



Simply open the "Symbol Manager" and drag and drop the object onto your screen.

To get you started, NT Series Support Tool includes a full library of keyboards and keypads.

**File Management**

File Management is made easy with NT Series Support Tool's Application Manager. Program files and screens are displayed in a tree structure so it's easy to find and reuse screen elements.

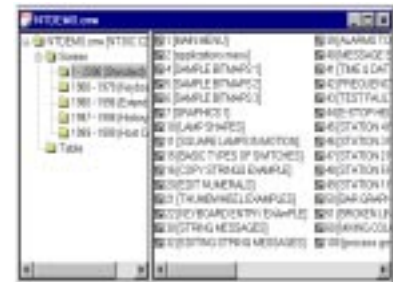

In addition, the Copy & Paste feature lets you quickly insert screens and files.

**Error Detection**

Simplify the process of troubleshooting your program. NT Series Support Tool's error log enables detection of errors such as capacity overload or stacking of touch switches in individual screens. Simply click on the error and automatically jump to its location for correction.

**Re-use screens / Quickly modify**

Save yourself valuable programming time with NT Series Support Tool. Working on multiple projects, changing or upgrading display models, or just upgrading a program in an existing display, NT Series Support Tool lets you quickly copy screens and programs from one application to another. And with its global search and replace, addressing can be changed quickly and easily.









FULL-FEATURED ALPHANUMERIC DISPLAY

FEATURES:

- Large characters
- Contrast control
- 4 line x 20 character backlit LCD
- 32 K memory (up to 250 screens)
- 4 programmable function keys
- Bar graph capability
- Password protect screens
- Printer port
- Host link/NT link communication
- NEMA 4
- Black or ivory front bezel



No space? No time? No problem! Our NT11S text-based 4 line x 20 character operator interface is the answer to your production needs. Compact (with the thinnest profile in the NT Series) and easy to operate, this full-featured operator interface allows accurate monitoring and controlling, and includes slide-in legends for quick customization of function keys. With the extra large keys of the NT11S keypad, you can manage it easily — even with heavy work gloves. And the NT11S uses a backlit LED LCD display providing a clearly visible screen in brightly lit areas.



Extra large numeric and function keys

SPECIFICATIONS

Display	
Type	Backlit LED LCD
Size	4 line x 20 character
Resolution	160 x 64 pixels
Touch cells	-
Viewing Angle	Left/Right ±35°
Electrical	
Power required	24 VDC
Power consumed	10 W max
Environmental	
Operating temp	0-+50°C (+32°-+122°F)
Storage temp	-20°-+70°C (-4°-+158°F)
Humidity	35-85% non-condensing
Ratings	NEMA 4
Approvals	UL / CSA / CE
Dimensions	218 <sub>w</sub> x113 <sub>H</sub> x38.2 <sub>D</sub> mm 8.58 <sub>w</sub> x4.45 <sub>H</sub> x1.50 <sub>D</sub> in
Weight	1 kg (2.20 lbs)
Display Capabilities	
Memory	32 K
Communication	Host Link / NT Link
Graphic Capabilities	
Bar graph	■
Text and Numeric	■
Marks	■

### Display advantage.

You can create easy-to-read message displays with the numeric and programmable function keys of the NT11S keypad. Character inversion, messaging, flash-



*Password security system*

ing, and bar graphs are just a few of the capabilities of this operator interface. Up to 250 screens can be programmed

into memory. And for those concerned about security, a password setting can be set per screen for critical machine operations.

### The key to communication.

Communication between operation site and PLC can unlock production barriers. By connecting the NT11S with a PLC using the Host Link or NT Link communication method, messages, numeric values, and control information can be sent to and received back from the PLC with fast updates and quick response times guaranteed.

### Rugged and adaptable.

Designed to operate in harsh surroundings, the NT11S is water resistant up to NEMA 4 standards.



*Withstands water and oil*

And with the NEMA 4 rating, you can be sure this terminal will readily stand up to water wash down environments. The NT11S also complies with UL/CSA/CE standards.

### Easy-to-use software.

The NT11S uses NT Series Support Tool, a simple programming package for creating screens and messages. It is the same software used for programming Omron Touchscreens. NT Series Support Tool requires a short learning curve and provides an easy transition when developing useful programs for Omron's Operator Interface Terminals.



*Ivory panel also available*

**DIMENSIONS**

mm (in)

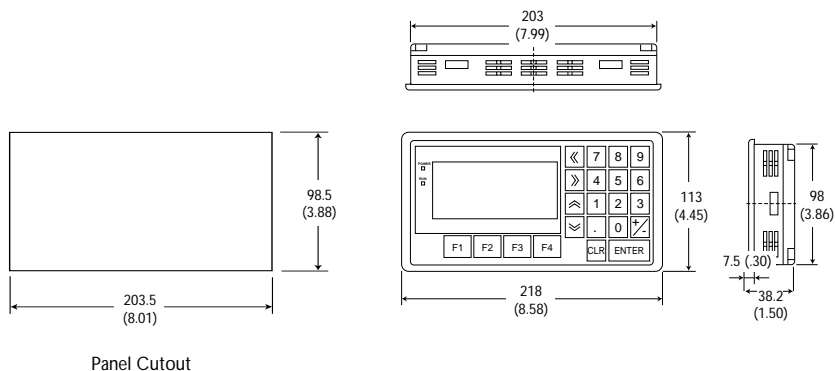

**ORDERING INFORMATION**

**Display**

4 x 20 Alphanumeric Display - Ivory	NT11S-SF121
4 x 20 Alphanumeric Display - Black	NT11S-SF121B

**Software**

NT Series Support Tool for NT11S/NT20/30/600/620	NT-ZJ3AT1-EV1
--	---------------

**Cables**

9-9 pin 50cm (1.6ft) NT-PLC Communication Cable	C200H-CN510-EU
9-9 pin 3m (9.8ft) NT-PLC Communication Cable	C200H-CN320-EU
9-9 pin 5m (16.4ft) NT-PLC Communication Cable	C200H-CN520-EU
9-25 pin 50cm (1.6ft) NT-PLC Communication Cable	C200H-CN519-EU
9-25 pin 3m (9.8ft) NT-PLC Communication Cable	C200H-CN329-EU
9-25 pin 5m (16.4ft) NT-PLC Communication Cable	C200H-CN529-EU

**Manuals**

NT11S Operation Manual	V029-E1-1
------------------------	-----------

**Additional Information**

Related NT11S Info	Page#
Applications	4
Communications	
Host Link	30
NT Link	31

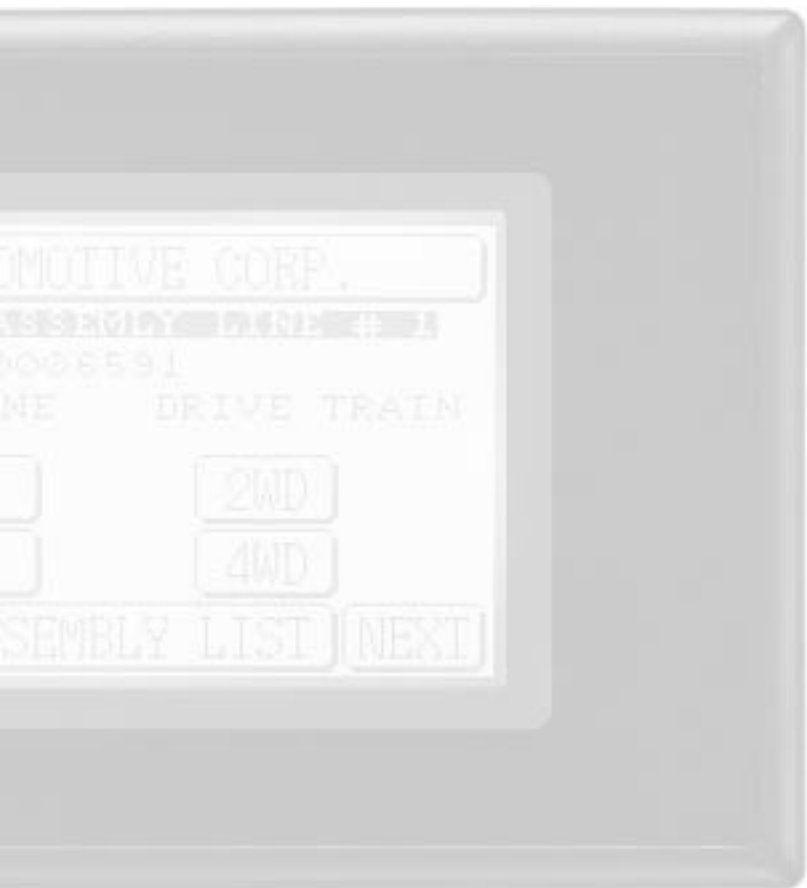

SPACE-SAVING  
SEMI-GRAPHIC  
TOUCH SCREEN PANEL



FEATURES:

- 5" diagonal display
- STN LCD touch screen
- 96 K memory
- Freeform drawing capabilities
- Host link/NT link (1:1/1:N)/C200H backplane communication
- NEMA 4
- Replaceable backlight
- Black or ivory front bezel

The biggest little terminal on the market. Omron's NT20S operator interface terminal offers you the convenience of touch screen control with the advantage of flexible, flat panel design. With a depth of only 54 mm, the NT20S easily builds into equipment and saves on valuable panel space. Choose Black or Blue LCD color to meet your application viewing needs. Blue is easier on the eyes; black offers the widest viewing angle. Maintenance is a breeze with the easily replaceable backlight. Display lifetime is increased while downtime is reduced. Less maintenance on the plant floor saves you time and money.



Slim 54 mm profile



Replaceable backlight

SPECIFICATIONS

Display	
Type	Black or Blue Backlit STN LCD
Size	5" diagonal
Resolution	240 x 128 pixels
Touch cells	72 per screen
Viewing Angle	Left/Right ±35°
Electrical	
Power required	24VDC
Power consumed	10 W max
Environmental	
Operating temp	0-+50°C (+32°-+122°F)
Storage temp	-20°-+70°C (-4°-+158°F)
Humidity	35-85% non-condensing
Ratings	NEMA 4
Approvals	UL / CSA / CE
Dimensions	190 <sub>w</sub> x110 <sub>H</sub> x58 <sub>D</sub> mm 7.48 <sub>w</sub> x4.33 <sub>H</sub> x2.28 <sub>D</sub> in
Weight	.7 kg (1.5 lbs)
Display Capabilities	
Memory	96 K
Communication	Host Link / NT Link (1:1/ 1:N) / C200H Interface
Graphic Capabilities	
Freeform drawing	■
Thumbwheel	■
Numeric keypad	■
History recording	■
Bar graph	■
Text and numeric	■
Custom graphics	■

**Pour it on.**

The NT20S can take it. This operator interface won't let you down when exposed to water or oil. The flat, flush surface construction of the terminal's front cover gives it a water resistance equivalent to NEMA 4, even without a protective cover. And with the NEMA 4 rating, the NT20S is a perfect fit for food processing or water wash down environments. The rugged NT20S also meets worldwide standards, complying with UL/CSA/CE requirements.

**Making a quick connection.**

Communication between operation site and PLC is as simple as the touch of a screen. By connecting the NT20S with a PLC using the Host Link, NT Link, or C200H Interface communication method, touch switch status, messages, numeric values, and control information can be sent to and received back from the PLC with changes immediately registered on the LCD display. Fast updates and quick response times are guaranteed. The NT20S now offers the NT Link 1:N connection which allows links to multiple operator interface units. Depending on the PLC CPU, a maximum of 8 operator interfaces can connect to one port. And with the C200H Interface backplane communication method, the terminal connects directly on the expansion port of the C200H backplane freeing up

the CPU's communication ports and slots. Using this C200H backplane bus provides exceptionally fast response speeds.

**Less is more.**

The NT20S costs you less but gives you more. More input functions, more graphics and more communications possibilities. With thumbwheel switches, you can input numerical values directly into the PLC without the need of a sequence program. You can easily change these values with just one touch and they can be subjected to an upper and lower limit check. This compact touch screen allows push-button control, alarm features, and machine and set-up help, making it easier for you to take control of your plant operation.

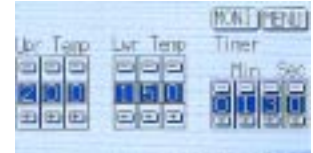

*Thumbwheel switches*

**Save time on design.**

Quickly create graphics, touch switches, and entire programs with Omron's NT Series Support Tool. Our easy-to-use software provides drawing tools similar to those found in commercial drawing packages. This gives seasoned designers all the options they need to create sophisticated graphics yet it's simple enough even for beginners to use in quick screen creation.



*Protective sheet shields display from dirt and scratches*



**DIMENSIONS**

mm (in)

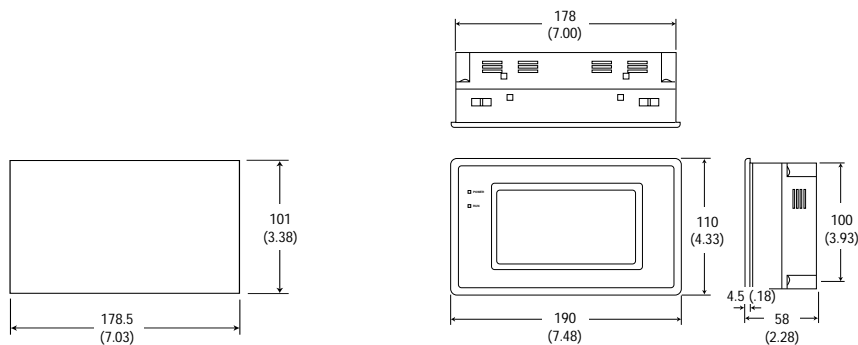

Panel Cutout

**ORDERING INFORMATION**

**Display**

**Blue LCD**

5" Backlit Touch Screen - Ivory	NT20S-ST121-EV3
5" Backlit Touch Screen - Black	NT20S-ST121B-EV3
5" Backlit Touch Screen C200H Connect - Ivory	NT20S-ST122-V1
5" Backlit Touch Screen C200H Connect - Black	NT20S-ST122B-V1

**Black LCD**

5" Backlit Touch Screen - Ivory	NT20S-ST161-EV3
5" Backlit Touch Screen - Black	NT20S-ST161B-EV3

**Software**

NT Series Support Tool for NT11S/NT20/30/600/620	NT-ZJ3AT1-EV1
Programming Cable 9-9 pin	C200H-CN229-EU
Programming Cable 9-25 pin	C200H-CN220-EU

**Accessories**

Backlight	NT20S-CFL01
Chemical Resistant Cover	NT20S-KBA01
Protective Sheet	NT20M-KBA04
RS232/422 Converter	NT-AL001

**Cables**

9-9 pin 50cm (1.6 ft) NT-PLC Communication Cable	C200H-CN510-EU
9-9 pin 3m (9.8 ft) NT-PLC Communication Cable	C200H-CN320-EU
9-9 pin 5m (16.4 ft) NT-PLC Communication Cable	C200H-CN520-EU
9-25 pin 50cm (1.6 ft) NT-PLC Communication Cable	C200H-CN519-EU
9-25 pin 3m (9.8 ft) NT-PLC Communication Cable	C200H-CN329-EU
9-25 pin 5m (16.4 ft) NT-PLC Communication Cable	C200H-CN529-EU
C200H 30cm (11.8 in) I/O Connecting Cable	C200H-CN311
C200H 70cm (2.3 ft) I/O Connecting Cable	C200H-CN711
C200H 2m (6.6 ft) I/O Connecting Cable	C200H-CN221
C200H 5m (16.4 ft) I/O Connecting Cable	C200H-CN521
C200H 10m (32.8 ft) I/O Connecting Cable	C200H-CN131

**Manuals**

NT20S Operation Manual	V020-E3-1
------------------------	-----------

**Additional Information**

Related NT20S Info	Page #
Software	7
Applications	4
Communications	
Host Link	30
NT Link	31
C200H Interface	33

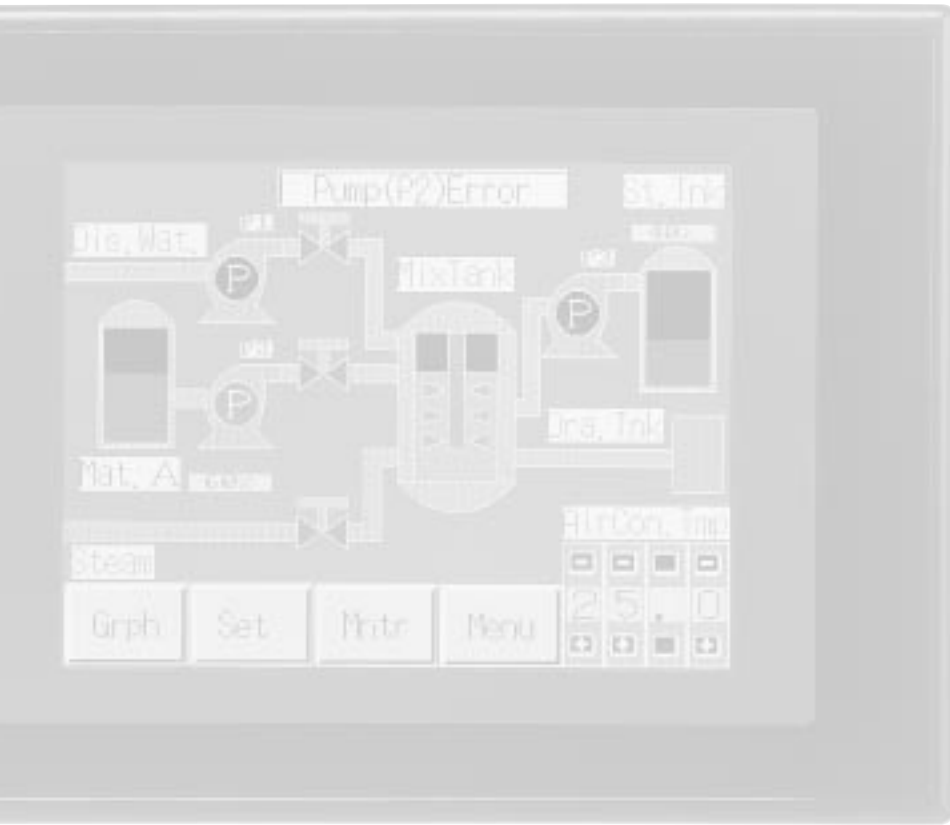

FULLY-GRAPHIC  
8-COLOR/BICOLOR  
TOUCH SCREEN PANEL

FEATURES:

- 5.7" diagonal display
- 8-color or bicolor STN LCD touch screen
- Battery-packed real-time clock
- Printer port
- 512 K memory
- Host link/NT link communication
- NEMA 4
- Replaceable backlight
- Black or ivory front bezel

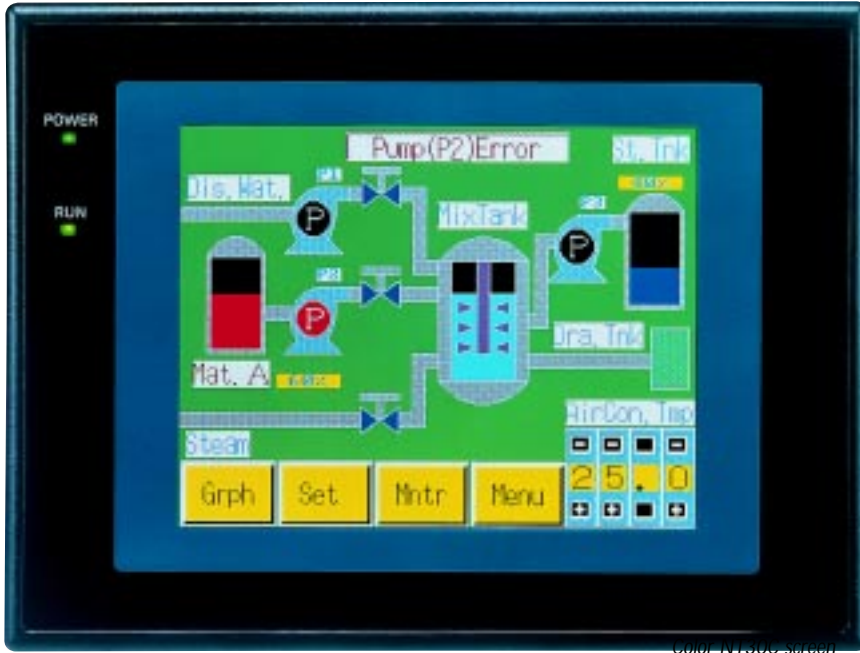

Color NT30C screen

A touch of color. Omron's NT30/30C operator interface terminal gives you the convenience of touch screen control with clear color capabilities. Omron



White NT30 screen



Red NT30 warning screen

offers two terminal options with easy-to-configure screens: the NT30C, a fully graphic eight-color display; and the NT30 bicolor display, which may be programmed to alternate between a white or a red screen. (This red screen is perfect for instantly alerting you to warnings and quickly identifying problem areas.) And with the high resolution 5.7 inch screen,

you're assured of readability even in brightly lit conditions. It's also easy to maintain. The replaceable backlight decreases down-time while increasing display lifetime. Less maintenance on the plant floor saves you time and money.



Replaceable backlight

SPECIFICATIONS

<b>Display</b>	
Type	Backlit STN LCD
Size	5.7" diagonal
Resolution	320 x 240 pixels
Touch cells	192 per screen
Viewing Angle	Left/Right ±35°
<b>Electrical</b>	
Power required	24 VDC
Power consumed	12 W max.
<b>Environmental</b>	
Operating temp	0-+50°C (+32°-+122°F)
Storage temp	-20-+70°C (-4°-+158°F)
Humidity	35-85% non-condensing
Ratings	NEMA 4
Approvals	UL / CSA / CE
Dimensions	195 <sub>w</sub> x142 <sub>H</sub> x55.6 <sub>D</sub> mm 7.68 <sub>w</sub> x5.59 <sub>H</sub> x2.19 <sub>D</sub> in
Weight	.7 kg (1.54 lbs)
<b>Display Capabilities</b>	
Memory	512 K
Communication	Host Link / NT Link
Real-time clock	Yes
<b>Graphic Capabilities</b>	
Freeform drawing	■
Bitmap	■
Tiling	■
Thumbwheel	■
Numeric keypad	■
History recording	■
Bar graph	■
Text and numeric	■
Custom graphics	■

## Right on time.

Omron's high resolution panel with built-in real-time clock and 512 K worth of memory equips you with a powerful control and information resource. The battery-backed real-time clock allows you to maintain a history of errors, alarm messages or production counts — a valuable aid in machine failure analysis. And hard copies of the screen may be printed, even during operation. You can easily display bar charts, broken line graphs and three sizes of thumbwheel switches. The NT30/30C also comes with a unique pop-up window function that makes more efficient use of screen space.



Screen hard copies during operation

Use these space saving pop-up windows to display such items as numeric or character input

keys, and help messages. Create eye-catching screens with bitmap images that you can use to graphically display anything from lamps and touch switches to company logos.

## Communication connection.

Communication between operation site and PLC is as simple as the touch of a screen. By connecting the NT30/30C with a PLC using the Host Link or NT Link communication method, touch switch status, messages, numeric values, and control information can be sent to and received back from the PLC with changes immediately registered on the LCD display. Fast

updates and quick response times are guaranteed. Extend the capabilities of the NT30/30C with our B7A Interface. Connecting



Omron's B7A Interface to the terminal gives you up to 32 external I/O points for use with hard-wired alarms and pushbuttons. The B7A saves on wiring expense and extends distance while providing more control and flexibility.

## Built to take it.

Slim and sturdy, the NT30/30C can withstand exposure to water and mist. Water resistant to NEMA 4 standards, even without a



NEMA 4 rating

protective cover, this terminal can be used with food processing machines and machine tools. The NT30/30C also meets UL/CSA/CE requirements.

## Screen design in less time.

Quickly create graphics, touch switches, and entire programs with Omron's NT Series Support Tool. Our easy-to-use software provides drawing tools similar to those found in commercial drawing packages. This gives seasoned designers all the options they need to create sophisticated graphics yet it's simple enough even for beginners to use in quick screen creation.

**DIMENSIONS**

mm (in)

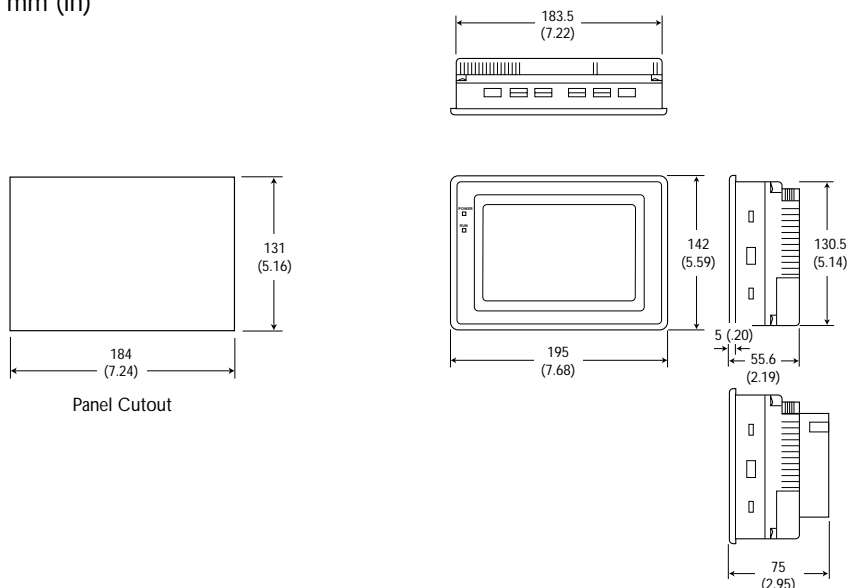

**ORDERING INFORMATION**

**Display**

5.7" Bicolor Backlit LCD Touch Screen - Ivory	NT30-ST131-E
5.7" Bicolor Backlit LCD Touch Screen - Black	NT30-ST131B-E
5.7" 8-color Backlit LCD Touch Screen - Ivory	NT30C-ST141-E
5.7" 8-color Backlit LCD Touch Screen - Black	NT30C-ST141B-E

**Software**

NT Series Support Tool for NT11S/NT20/30/600/620	NT-ZJ3AT1-EV1
Programming Cable 9-9 pin	C200H-CN229-EU
Programming Cable 9-25 pin	C200H-CN220-EU

**Accessories**

Backlight for NT30	NT30-CFL01
Backlight for NT30C	NT30C-CFL01
B7A Interface Unit In 16(8) / Out 16(8)	NT-B7A16
Chemical Resistant Cover for NT30/30C	NT30-KBA01
Protective Sheet for NT30/30C	NT30-KBA04
Battery	3G2A9-BAT08
RS232/422 Converter	NT-AL001
NT to Printer Cable	NT-CNT121

**Cables**

9-9 pin 50cm (1.6 ft) NT-PLC Communication Cable	C200H-CN510-EU
9-9 pin 3m (9.8 ft) NT-PLC Communication Cable	C200H-CN320-EU
9-9 pin 5m (16.4 ft) NT-PLC Communication Cable	C200H-CN520-EU
9-25 pin 50cm (1.6 ft) NT-PLC Communication Cable	C200H-CN519-EU
9-25 pin 3m (9.8 ft) NT-PLC Communication Cable	C200H-CN329-EU
9-25 pin 5m (16.4 ft) NT-PLC Communication Cable	C200H-CN529-EU

**Manuals**

NT30/30C Operation Manual	V034-E1-1
---------------------------	-----------

**Additional Information**

Related NT30/30C Info	Page #
Software	7
Applications	4
Communications	
Host Link	30
NT Link	31



LARGE TOUCH SCREEN SEMI-GRAPHIC PANEL



NT600S LCD screen

Size it up. Compared to other operator interface terminals on the market, Omron's NT600S is the clear choice for value offering a large touch screen display

at a small touch screen price. With its surprisingly slim, flat panel design and spacious 9" display, you can install this operator interface just about anywhere and still easily see the screen.



Electroluminescent screen

You won't strain your eyes, even in brightly lit areas. Choose from the standard STN LCD touch screen or the wide-angle electroluminescent display. Our electroluminescent model gives you an extra-wide viewing angle, making the information you need just a glance away.

FEATURES:

- 9" diagonal display
- STN LCD or EL touch screen
- 128 K memory
- Host link/NT link(1:1/1:N)/C200H backplane communication
- NEMA 4
- Replaceable backlight on LCD
- Black or ivory front bezel

SPECIFICATIONS

Display	
Type	Backlit STN LCD or Electroluminescent (EL)
Size	9" diagonal
Resolution	640 x 400 pixels
Touch cells	128 per screen
Viewing Angle	Left/Right ±50° on LCD Left/Right ±80° on EL

Electrical	
Power required	24 VDC
Power consumed	Less than 15 W on LCD Less than 25 W on EL

Environmental	
Operating temp	0-+50°C (+32°-+122°F)
Storage temp	-20-+70°C (-4°-+158°F)
Humidity	35-85% non-condensing
Ratings	NEMA 4
Approvals	UL / CSA / CE
Dimensions	275wx192hx71D mm 10.83wx7.56hx2.80D in
Weight	1.8 kg (3.97 lbs)

Display Capabilities	
Memory	128 K
Communication	Host Link / NT Link (1:1/1:N) C200H Interface

Graphic Capabilities	
Freeform drawing	■
Thumbwheel	■
Numeric keypad	■
History recording	■
Bar graph	■
Text and Numeric	■
Custom Graphics	■

**Constructed to last.**

The NT600S complies with worldwide environmental standards, withstanding exposure to water or oil.

The flat, flush surface construction of the terminal's



*Protective sheet shields display from dirt and scratches*

front cover gives it a water resistance equivalent to IP65, even without a protective cover. And NEMA 4 ratings ensure it functions in food processing or water wash down environments.

The NT600S also meets UL/CSA/CE requirements.

**Quick to connect.**

Communication between operation site and PLC is as simple as the touch of a screen. By connecting the NT600S with a PLC using the Host Link, NT Link, or C200H Interface communication method, touch switch status, messages, numeric values, and control information can be sent to and received back from the PLC with changes immediately registered on the LCD/EL display. With the new NT Link 1:N method, the NT600S offers more communication options than ever before. Depending on the PLC CPU, up to 8 operator interfaces can be connected to one port. And with the C200H Interface backplane communication method, the terminal connects directly on the expansion port of the C200H backplane freeing up the

CPU's communication ports and slots. Using this C200H back plane bus provides exceptionally fast response speeds.

**Valuable input.**

The large touch screen of the NT600S offers a wide display area for working with input functions and graphics. The many graphic capabilities available give you a realistic representation of pushbuttons, lamps, bar graphs and thumbwheel switches.



*Slim 65mm profile*

Thumbwheel switches allow you to input numeric values directly into the PLC without the need of a sequence program saving valuable program memory. And with the freeform drawing capabilities of the NT600S, you can create a graphic display of machine, assembly, or process status complete with alarm, control, and help messages.

**Save time on design.**

Quickly create graphics, touch switches, and entire programs with Omron's NT Series Support Tool. Our easy-to-use software provides drawing tools similar to those found in commercial drawing packages. This gives seasoned designers all the options they need to create sophisticated graphics yet it's simple enough even for beginners to use in quick screen creation.



*Replaceable backlight on LCD screen*



**DIMENSIONS**

mm (in)

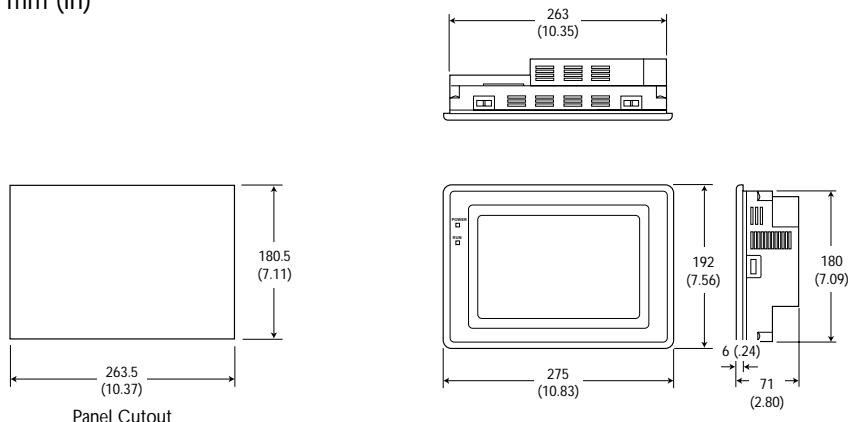

**ORDERING INFORMATION**

**Display**

9" LCD Touch Screen - Ivory	NT600S-ST121-EV3
9" LCD Touch Screen - Black	NT600S-ST121B-EV3
9" Electroluminescent Touch Screen - Ivory	NT600S-ST211-EV3
9" Electroluminescent Touch Screen - Black	NT600S-ST211B-EV3

**Software**

NT Series Support Tool for NT11S/NT20/30/600/620	NT-ZJ3AT1-EV1
Programming Cable 9-9 pin	C200H-CN229-EU
Programming Cable 9-25 pin	C200H-CN220-EU

**Accessories**

Backlight for NT600S	NT600S-CFL01
C200H Direct Connect Interface	NT-LB122
Chemical Resistant Cover for NT600S	NT600S-KBA01
Protective Sheet for NT600S/620S	NT600M-KBA04
Battery	3G2A9-BAT08
RS232/422 Converter	NT-AL001

**Cables**

9-9 pin 50cm (1.6 ft) NT-PLC Communication Cable	C200H-CN510-EU
9-9 pin 3m (9.8 ft) NT-PLC Communication Cable	C200H-CN320-EU
9-9 pin 5m (16.4 ft) NT-PLC Communication Cable	C200H-CN520-EU
9-25 pin 50cm (1.6 ft) NT-PLC Communication Cable	C200H-CN519-EU
9-25 pin 3m (9.8 ft) NT-PLC Communication Cable	C200H-CN329-EU
9-25 pin 5m (16.4 ft) NT-PLC Communication Cable	C200H-CN529-EU
C200H 30cm (11.8 in) I/O Connecting Cable	C200H-CN311
C200H 70cm (2.3 ft) I/O Connecting Cable	C200H-CN711
C200H 2m (6.6 ft) I/O Connecting Cable	C200H-CN221
C200H 5m (16.4 ft) I/O Connecting Cable	C200H-CN521
C200H 10m (32.8 ft) I/O Connecting Cable	C200H-CN131

**Manuals**

NT600S Operation Manual	V022-E3-1
-------------------------	-----------

**Additional Information**

Related NT600S Info	Page#
Software	7
Applications	4
Communications	
Host Link	30
NT Link	31
C200H Interface	33

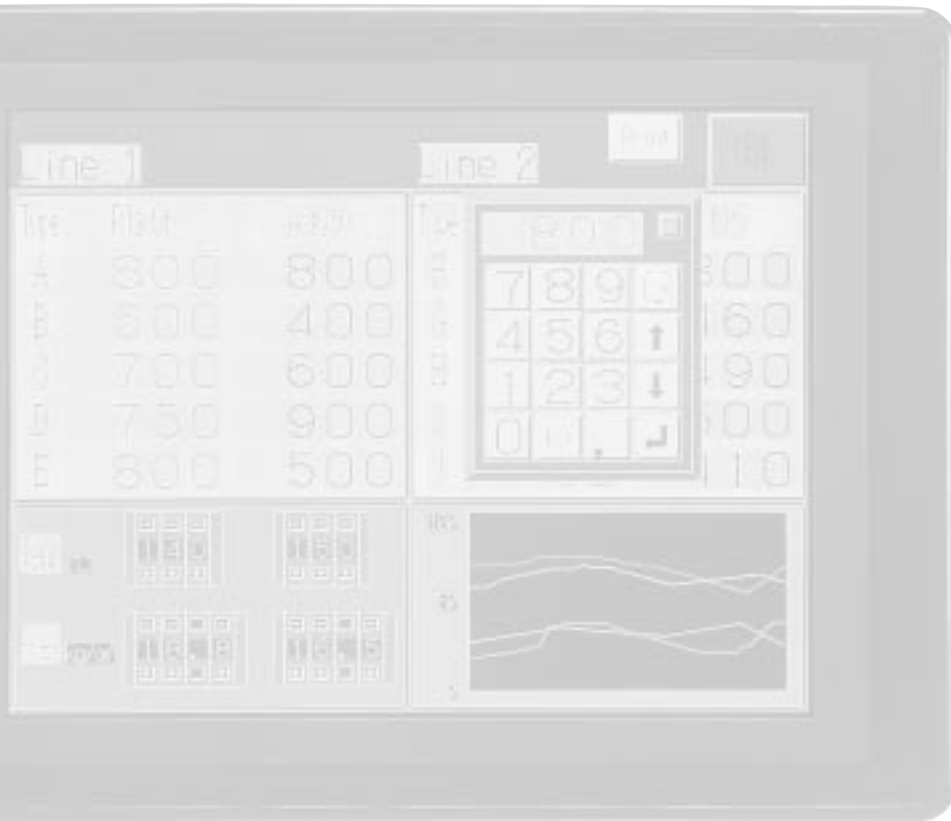

MULTIFUNCTION  
FULLY-GRAPHIC  
TOUCH SCREEN PANEL

FEATURES:

- 9.7" color STN LCD touch screen or 9" electroluminescent display
- Battery-packed real-time clock
- Printer port
- 1 MB memory
- Host link/NT link (1:1/1:N)
- NEMA 4
- Replaceable backlight on LCD
- Black or ivory front bezel

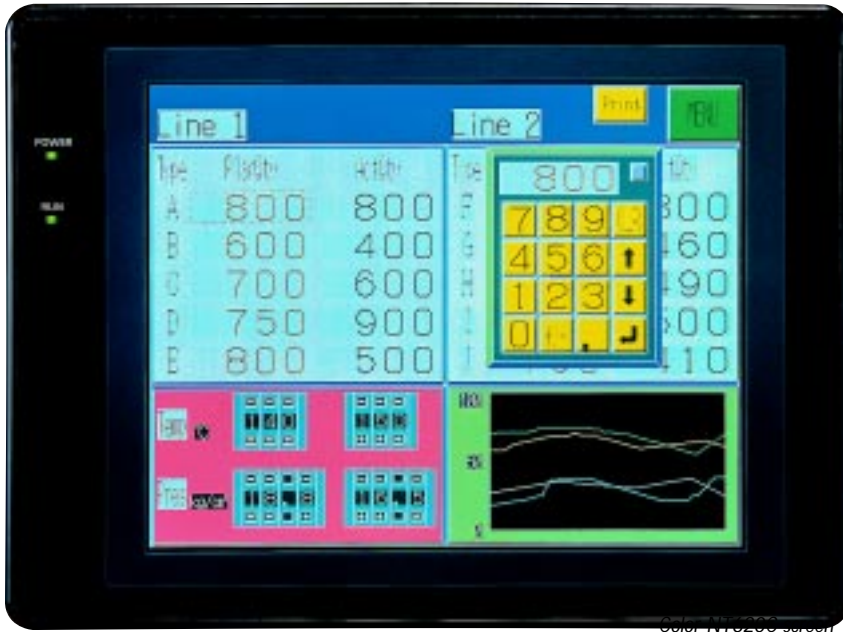

Color NT620C screen

Color, Memory and Size — the big three in operator interface terminals and the NT620C has them all. A fully graphic eight-color STN LCD terminal, 1 MB of memory and a large touch screen allow you easy, on-site access to important information. Screens are clear and colorful, making images easily identifiable. Our top-

of-the-line operator interface terminal also comes in an electroluminescent model. This EL screen has an extra-wide viewing angle that lets you see it from a distance. No need to go all the way to the screen to get

a reading, just a quick glance will give you the information you need — fast.



Electroluminescent screen

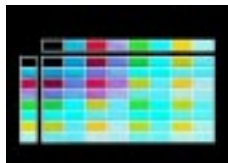

8-color variations displayed on the NT620C screen

SPECIFICATIONS

<b>Display</b>	
Type	Backlit STN LCD or Electroluminescent (EL)
Size	9.7" LCD or 9" EL
Resolution	640 x 480 pixels LCD or 640 x 400 pixels EL
Touch cells	768 LCD or 512 EL
Viewing Angle	Left/Right ±30° LCD or Left/Right ±80° EL
<b>Electrical</b>	
Power required	24 VDC
Power consumed	30 W or less on LCD or 25 W or less on EL
<b>Environmental</b>	
Operating temp	0-+40°C (+32°-+104°F) LCD 0-+45°C (+32°-+113°F) EL
Storage temp	-20-+60°C (-4°-+140°F) LCD -20-+70°C (-4°-+158°F) EL
Humidity	35-85% non-condensing
Ratings	NEMA 4
Approvals	UL / CSA / CE
Dimensions of LCD	275 <sub>w</sub> x196 <sub>H</sub> x76.8 <sub>D</sub> mm 10.83 <sub>w</sub> x7.72 <sub>H</sub> x3.02 <sub>D</sub> in
Dimensions of EL	275 <sub>w</sub> x192 <sub>H</sub> x71 <sub>D</sub> mm 10.83 <sub>w</sub> x7.56 <sub>H</sub> x2.80 <sub>D</sub> in
Weight	2.0 kg (4.41 lbs)
<b>Display Capabilities</b>	
Memory	1 MB LCD or 512 K EL
Communication	Host Link / NT Link(1:1/1:N)
Real-time clock	Yes
<b>Graphic Capabilities</b>	
Freeform drawing	■
Bitmap	■
Tiling	■
Thumbwheel	■
Numeric keypad	■
History recording	■
Bar graph	■
Text and numeric	■
Custom graphics	■

**Time on your hands.**

With this high resolution panel's built-in real-time clock and myriad of communication possibilities, you gain hands-on control of your plant operation. The battery-backed real-time clock allows you to maintain a history of errors, alarm messages or production counts — a valuable aid in machine analysis. And hard copies of the screen may be printed, even during operation. You can easily display bar charts, broken line graphs and thumbwheel switches. With broken line graphs, the interval on the horizontal axis can be set without restriction, and the set values on the vertical axis can be changed even during operation. Thumbwheel switches let you quickly input numerical values directly into the PLC without using a sequence program — a real time saver. Bitmap images can save you time too. Use them for graphically displaying anything from lamps and touch switches to company logos.



Use pop-up windows to display numeric and character input keys and help messages.

interval on the horizontal axis can be set without restriction, and the set values on the vertical axis can be changed even during operation. Thumbwheel switches let you quickly input numerical values directly into the PLC without using

a sequence program — a real time saver. Bitmap images can save you time too. Use them for graphically displaying anything from lamps and touch switches to company logos.

**Low maintenance, high quality.**

Built tough and water resistant, the NT620S/620C stands up to harsh environments. Water and oil are no match for this terminal which meets NEMA 4 standards, even without a protective cover. The NEMA 4 rating ensures it will function in water wash down environments. This gives you more location choices when installing your



Replaceable backlight

terminal. And because the LCD screen comes with a replaceable backlight, maintenance is simple. The NT620S/620C also meets UL/CSA/CE requirements.

**Quick connection capabilities.**

Communication between operation site and PLC is as simple as the touch of a screen. By connecting the NT620S/620C with a PLC using the Host Link or NT Link communication method, touch switch status, messages, numeric values, and control information can be sent to and received back from the PLC with changes immediately registered on the LCD/EL display. Fast updates and quick response times are guaranteed.

The NT620S/C now has NT Link 1:N capabilities for connecting multiple operator interfaces to select PLC CPU ports. With Memory Link, the NT620S/C offers more communications capability than ever before. When using a Memory Link, communication with an NT620S/C is executed using RS-232C/422A communication from the host. Both Memory Link and NT Link are enabled using the appropriate system installer.

**Less time on design.**

Quickly create graphics, touch switches, and entire programs with Omron's NT Series Support Tool. Our easy-to-use software provides drawing tools similar to those found in commercial drawing packages. This gives seasoned designers all the options they need to create sophisticated graphics yet it's simple enough even for beginners to use in quick screen creation.

**DIMENSIONS**

mm (in)

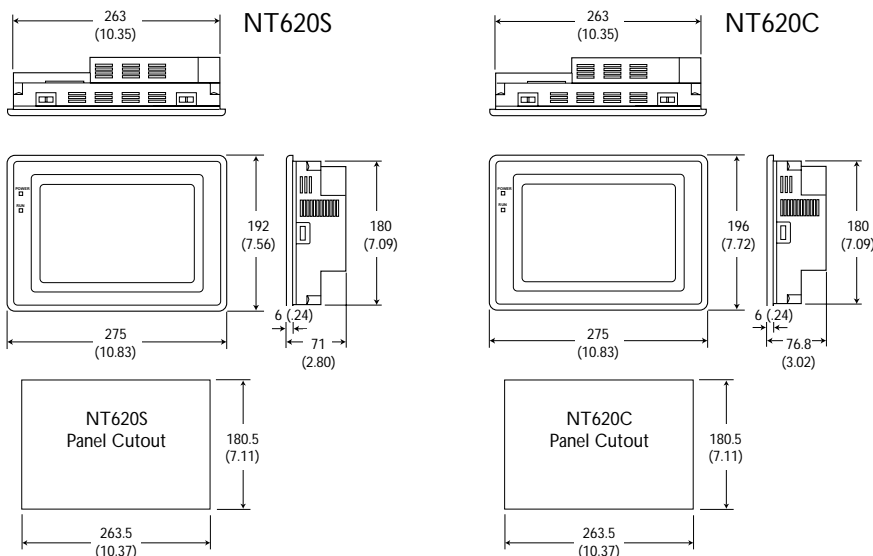

**ORDERING INFORMATION**

**Display**

9.7" 8-color Backlit LCD Touch Screen - Ivory	NT620C-ST141-E
9.7" 8-color Backlit LCD Touch Screen - Black	NT620C-ST141B-E
9" Electroluminescent Touch Screen - Ivory	NT620S-ST211-E
9" Electroluminescent Touch Screen - Black	NT620S-ST211B-E

**Software**

NT Series Support Tool for NT11S/NT20/30/600/620	NT-ZJ3AT1-EV1
System Installer for Host Link, NT Link(1:1/1:N)	NT620-ZS3AT-EV1
System Installer for Memory Link	NT620-ZS3AT-EMV1
Programming Cable 9-9 pin	C200H-CN229-EU
Programming Cable 9-25 pin	C200H-CN220-EU

**Accessories**

Backlight for NT620C	NT620C-CFL01
Chemical Resistant Cover for NT620C	NT620C-KBA01
Chemical Resistant Cover for NT620S	NT600S-KBA01
Protective Sheet for NT620C	NT620C-KBA04
Protective Sheet for NT620S/600S	NT600M-KBA04
Battery	3G2A9-BAT08
RS232/422 Converter	NT-AL 001
NT to Printer Cable	NT-CNT121

**Cables**

9-9 pin 50cm (1.6 ft) NT-PLC Communication Cable	C200H-CN510-EU
9-9 pin 3m (9.8 ft) NT-PLC Communication Cable	C200H-CN320-EU
9-9 pin 5m (16.4 ft) NT-PLC Communication Cable	C200H-CN520-EU
9-25 pin 50cm (1.6 ft) NT-PLC Communication Cable	C200H-CN519-EU
9-25 pin 3m (9.8 ft) NT-PLC Communication Cable	C200H-CN329-EU
9-25 pin 5m (16.4 ft) NT-PLC Communication Cable	C200H-CN529-EU

**Manuals**

NT620S/620C Operation Manual	V033-E3-2
------------------------------	-----------

**Additional Information**

Related NT620S/620C Info	Page #
Software	7
Applications	4
Communications	
Host Link	30
NT Link	31

COMMUNICATION METHOD	NT11S	NT20S	NT30 NT30C	NT600S	NT620S NT620C
HOST LINK	■	■	■	■	■
NT LINK 1:1	■	■	■	■	■
NT LINK 1:N		■		■	■
MEMORY LINK					■
C200H DIRECT CONNECTION		■		■	

HOST LINK

The Host Link communication method is built into our full line of Omron NT Series Terminals. Communication baud rates range from 9,600 to 19,200 bps with a typical response speed of .5 seconds. With Host Link, you can connect multiple terminals to a single PLC (up to six on the C200Hα system) gaining greater accessibility and multiple views of your larger applications.

APPLICABLE PLCS

- SYSMAC-
  - CVM1/CV Series (EV1, 2 versions only)
  - C200HX/HG/HE
  - C200HS / C200H
  - CQM1 (except CPU11)
  - CPM1 with CIF cable
  - CPM1A with CIF cable
  - SRM1
  - C-SERIES Hostlink Unit

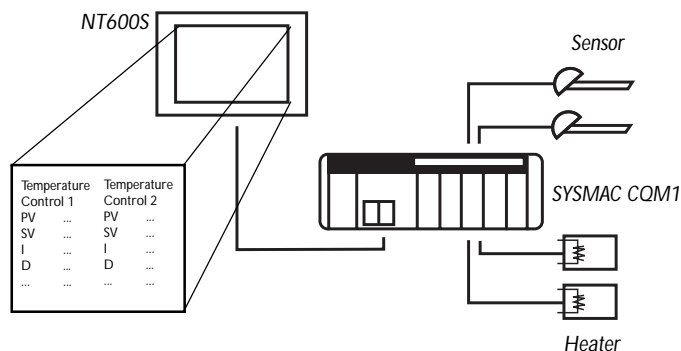
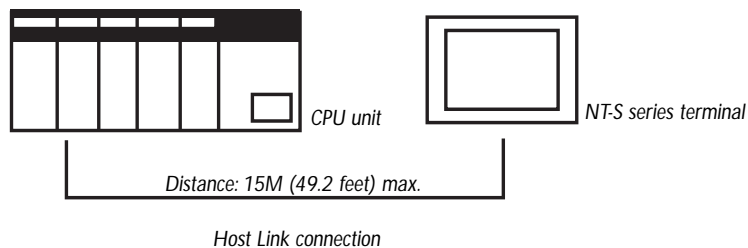

Host Link Application

OPERATOR INTERFACE-PLC HOST LINK 1:N CONNECTION EXAMPLES

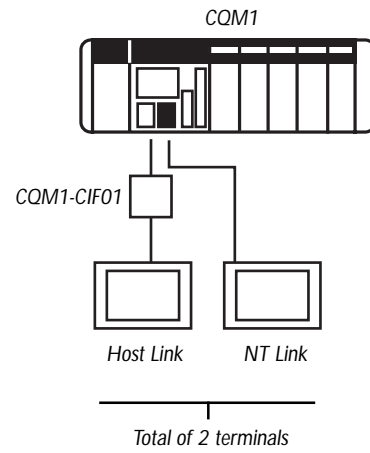
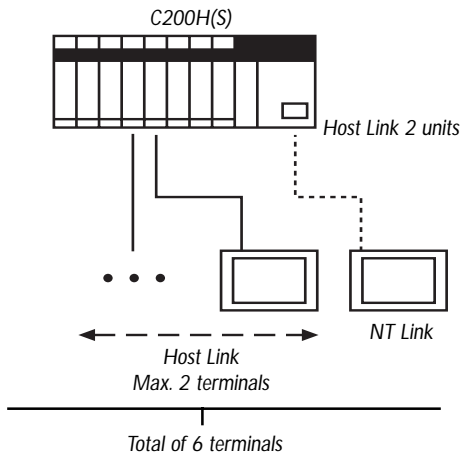
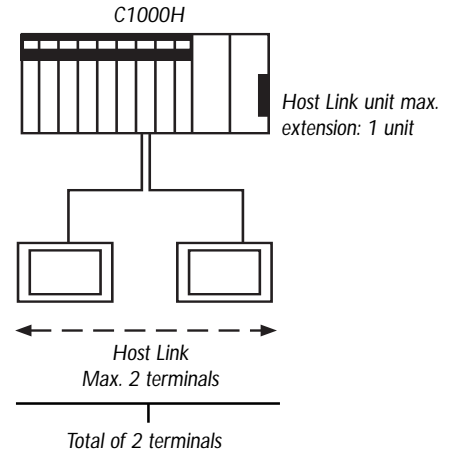
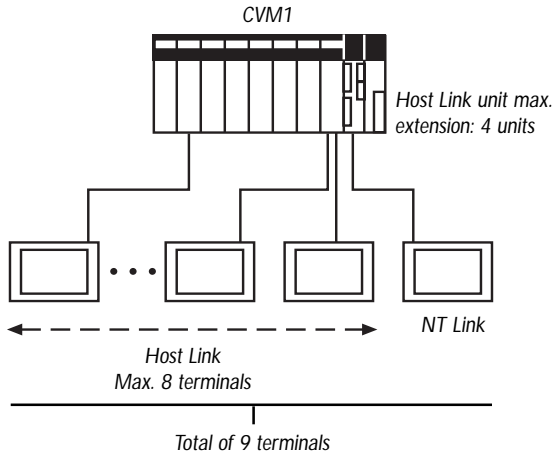

NT LINK 1:1

Omron's NT Link communication method can rapidly transmit large amounts of data. With response speeds of up to .2 seconds, NT Link displays important information fast. When you need a guarantee of high speed data delivery on your time critical applications, use NT Link, Omron's fastest communication method for operator interface terminals.

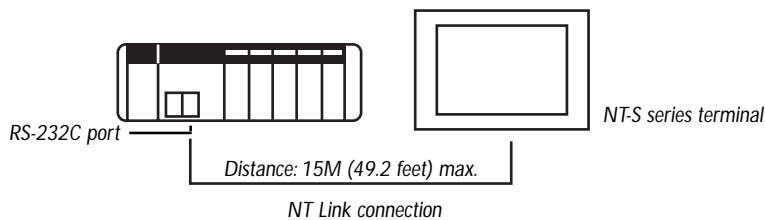

NT Link connection

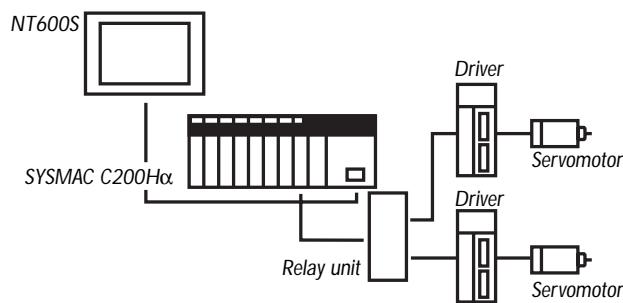

NT Link Application

APPLICABLE PLCS

SYSMAC-

- CVM1/CV Series (EV1, 2 versions only)
- C200HX/HG/HE (excluding C200HE-CPU11)
- C200HS-CPU3\_ / CPU2\_
- CQM1-CPU4\_-E
- CPM1 with CIF cable
- CPM1A with CIF cable
- SRM1

NT LINK 1:N

Omron's NT Link 1:N connection allows links to multiple machines. The number of connections possible varies depending on the SYSMAC α model. By installing a communication board in the option slot of the CPU unit, it is possible to connect up to three NT Link (1:N) systems, comprising a total of 24 operator interface units.

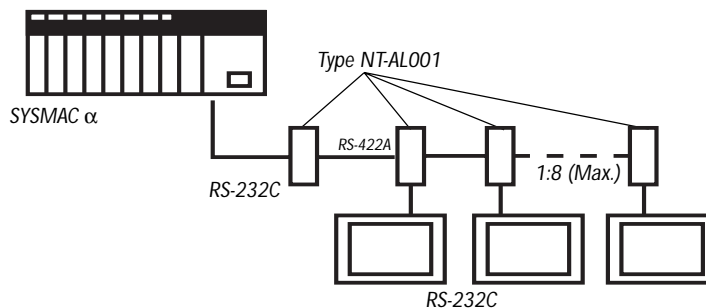

The NT-AL001 RS-232C/422A converter unit is sold separately. When connecting the C200HX/HG/HE and NT-AL001, use a converter unit whose lot number is 15Y5 or higher.

APPLICABLE PLCS

- C200HE (except CPU11) : 4 units per port
- C200HX/HG : 8 units per port



MEMORY LINK (NT620S/C)

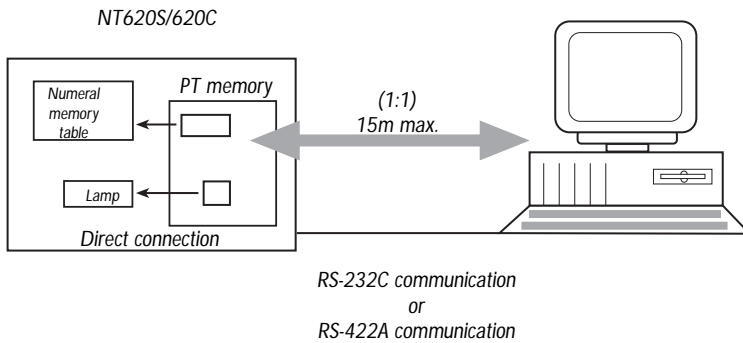

The Memory Link is a new communications method which allows use of the direct connection function from an Omron third party host with RS-232C/422A communications. Memory Link achieves faster data throughput by allocating a virtual memory area in the operator interface. The functions are equivalent to those of other direct connection methods.

APPLICABLE HOSTS

- Single Board Computer
- Personal Computer
- PLC

C200H DIRECT CONNECTION

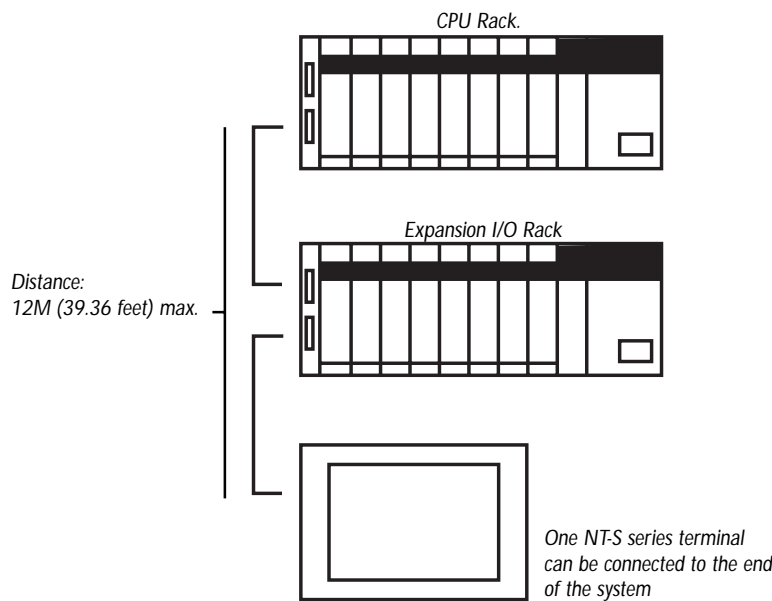

C200H Direct Communication

Available on the NT20S and NT600S terminals, the C200H Interface Backplane direct connection method allows you to communicate directly to the expansion port of the C200H backplane. With this direct connection method freeing up the CPU's communication ports and slots, there's no need to purchase additional host link modules. And because this communication method is compatible with Host Link communication, you can connect multiple terminals to a single PLC.

APPLICABLE PLCS

- C200HX/HG/HE
- C200H(S)
- C20H Series

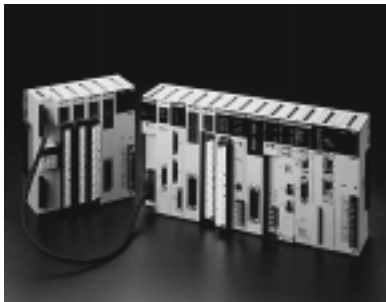

## LARGE RACK PLC SYSTEMS

Omron's CV Series Programmable Controllers combine powerful, high-speed industrial control with the industry's most advanced data communications capability enabling you to manage factory control and production data in a single platform. The CV's extensive selection of more than 80 standard and special application modules and family compatibility with other Omron PLCs make it an ideal solution for long term factory automation expansion.



## MID-SIZED PLC SYSTEMS

The C200H Alpha PLC is the most recent enhancement of Omron's advanced line of powerful and versatile mid-sized PLCs. With its large rack capability in a mid-sized package, the C200H Alpha offers the industry's best value in machine control, networking and data communications. Designed to be closely integrated with other Omron PLCs, the C200H Alpha provides an ideal platform for advanced cell or machine control while minimizing training, peripheral and maintenance costs.



## SMALL AND MICRO PLCS

Omron virtually pioneered the small and micro PLC market and has set the standard in cost/performance value ever since. The remarkably versatile CQM1, and the cost effective CPM1/A let you manage high-speed control and inspection applications in space-conscious packages. Continuing Omron's pioneering spirit, the new SRM1 Micro Network Controller offers the industry's first networkable micro PLC. The compact (about the size of a pack of cigarettes) CPU controls its versatile I/O terminals via high-speed twisted pair wires and provides unmatched flexibility and cost savings for small machine control.



## PROGRAMMING TOOLS AND PERIPHERALS

All Omron PLCs may be programmed using SYSMAC CPT, a single easy-to-use Windows-based package that simplifies program development, documentation, maintenance and troubleshooting. Powerful ON- and OFF-line editing and monitoring tools give you unparalleled access to your program for quick troubleshooting and modification.

## MEASUREMENT/INSPECTION SENSORS AND MACHINE VISION

Omron's measurement/inspection sensors and machine vision systems let you automatically build quality in-line rather than manually inspect it in at the end of the production run. These highly accurate, non-contact sensors offer micron level resolution to detect proper position, displacement, size, hole depth, surface defects and many other parameters. All are designed for easy integration with other Omron products.



## AUTO ID/ELECTRONIC DATA TRACKING

Omron Automatic Identification products let you better manage production by enabling you to electronically track the status of products and assemblies throughout the production process. Radio Frequency Identification (RFID) products act like a portable, updateable database – truly enabling the "Lots of One" or "Mass Customization" potential for manufacturing. For basic identification purposes, Omron's Bar Code Readers offer unmatched flexibility and functionality. All are designed for easy integration with other Omron products.



## SENSORS, LIMIT SWITCHES AND ENCODERS

No other automation company offers a wider range of problem-solving sensing solutions than Omron. Choose from photoelectric, proximity, capacitive, limit switches, incremental and absolute encoders and more. All are available in a wide range of sizes, housing styles, sensing ranges, and mounting options. Advanced versions include built-in diagnostics and alarm outputs that automatically detect failing sensing conditions and send alarm signals.



## TEMPERATURE AND PROCESS CONTROLLERS, TIMERS, COUNTERS AND DIGITAL PANEL METERS

Omron's advanced, yet easy-to-use temperature and process controllers pack extraordinary functionality and high accuracy into standard 1/4-, 1/8- and 1/16-DIN sizes. Timers and counters provide easy, low-cost interface for machine operators and come in a variety of styles, including multifunction and analog types. A family of high visibility digital panel meters provides simple displays to advance multi-output functionality.



## AMERICAS

### USA

Omron Electronics, Inc.  
One East Commerce Drive  
Schaumburg, Illinois 60173  
Phone: (800) 55-OMRON  
Fax: (847) 843-7787

### Atlanta

Omron Electronics  
Technology Park  
655 Engineering Drive, Suite 130  
Norcross, Georgia  
Phone: (770) 798-6780  
Fax: (770) 798-6788

### Boston

Omron Electronics  
65 Boston Post Road  
Marlborough, MA 01752  
Phone: (508) 303-8880  
Fax: (508) 303-8881

### Chicago

Omron Electronics  
1300 Basswood, Suite 300  
Schaumburg, IL 60173  
Phone: (847) 843-7910  
Fax: (847) 882-2192

### Cincinnati

Omron Electronics  
8160 Corporate Park Drive, Suite 100  
Cincinnati, Ohio 45242  
Phone: (513) 469-6766  
Fax: (513) 469-5737

### Dallas

Omron Electronics  
1501 LBJ Freeway, Suite 160, MS109  
Dallas, Texas 75234  
Phone: (972) 241-2597  
Fax: (972) 247-2436

### Los Angeles

Omron Electronics  
750 The City Drive South, Suite 120  
Orange, California 92868  
Phone: (714) 621-3455  
Fax: (714) 937-6366

### Philadelphia

Omron Electronics  
180 Sheree Boulevard, Suite 3800  
Exton, Pennsylvania 19341-1280  
Phone: (610) 524-1897  
Fax: (610) 524-5631

### BRAZIL

Omron Electronica do Brasil, Ltda.  
Rua Palacete Das Aguias  
154 Vila Alexandria CEP 04635-020  
São Paulo-SP, Brazil  
Phone: 55-11-536-0211  
Fax: 55-11-531-1890

### CANADA

Omron Canada, Inc.  
885 Milner Avenue  
Scarborough, Ontario M1B 5V8  
Phone: (416) 286-6465  
Fax: (416) 286-6648

### Ontario

Omron Kitchener  
60 New Dundee Road  
Kitchener, Ontario N2G 3W5  
Phone: (519) 896-1144  
Fax: (519) 896-0333

### British Columbia

Omron Canada  
1600 Derwent Way, Unit 3  
Annacis West Business Centre  
Delta, British Columbia V3M 6M5  
Phone: (604) 522-8855  
Fax: (604) 522-9306

### Alberta

Omron Canada  
3204 74th Street  
Edmonton, Alberta T6K 1J6  
Phone: (403) 440-0818  
Fax: (403) 462-9327

### Quebec

Omron Canada  
1825 32nd Avenue  
Lachine, Quebec H8T 3J1  
Phone: (514) 636-6676  
Fax: (514) 636-2959

Omron Canada  
3107 Des Hotels #10  
Ste-Foy, Quebec G1W 4W5  
Phone: (418) 658-2735  
Fax: (418) 658-9072

## EUROPE

### AUSTRIA

Omron Electronics G.m.b.H.  
Altmannsdorfer Strasse 142  
Vienna, Austria, A-1231  
Phone: 43-1-801-90-0  
Fax: 43-1-804-48-46

### BELGIUM

Omron Electronics N.V./S.A.  
Stationsstraat 24  
Groot-Bijgaarden, Belgium, B-1702  
Phone: 32-2-466-2480  
Fax: 32-2-466-0687

### CZECH REPUBLIC

Omron Electronics Spol. S.R.O.  
Srobarova 6  
CZ-101 00 Prague 10  
Phone: 42-2-67311-254  
Fax: 42-2-740333

### DENMARK

Omron Electronics A/S  
Odinsvej 15  
Glostrup, Denmark, DK-2600  
Phone: 45-43-44-00-11  
Fax: 45-43-44-02-11

### FINLAND

Omron Electronics O.Y.  
Metsanpojankuja 5  
Espoo Finland FIN-02130  
Phone: 358-0-5024-210  
Fax: 358-0-5024-2150

### FRANCE

Omron Electronics S.a.r.l.  
BP 33, 19 Rue Du Bois Galon  
Fontenay-Sous-Bois/Cedex  
Paris, France, F-94121  
Phone: 33-1-4974-7000  
Fax: 33-1-4876-2795

### GERMANY

Omron Electronics G.m.b.H.  
Itterpark 2-4  
Hilden, Düsseldorf, Germany 40724  
Phone: 49-2103-203-3  
Fax: 49-2103-203-400

### GREECE

Kalamarakis & Sapounas, S.A.  
10 Great Kydonion Street  
Athens, Greece, GR-111 44  
Phone: 30-1-2235-511/512/513  
Fax: 30-1-2027-500

### HUNGARY

Omron Electronics Kft.  
Rokolya u. 1-13  
Budapest, Hungary, H-1131  
Phone: 36-1-129-5492  
Fax: 36-1-129-8454

### IRELAND

Omron Electronics Ltd.  
Delaire Building Sallynoggin Road  
Dun Laoghaire Co. Dublin, Ireland  
Phone: 353-1-2897382  
Fax: 353-1-2840267

### ITALY

Omron Electronics S.r.l.  
Viale Certosa 49  
Milano, Italy, 20149  
Phone: 39-2-32-68-1  
Fax: 39-2-32-51-54

### NETHERLANDS

Omron Electronics B.V.  
Wegalaan 61  
JD Hoofddorp, Netherlands, NL-2132  
Phone: 31-2356-81-100  
Fax: 31-2356-81-188

### NORWAY

Omron Electronics Norway A/S  
Ole Deviks Vei 4  
Oslo, Norway, N-0611  
Phone: 47-22-65-75-00  
Fax: 47-22-65-83-00

### POLAND

Omron Electronics  
ulitsa Fortaczna 5  
Warsaw, Poland PL 01 540  
Phone: 48-22-39-2935  
Fax: 48-22-39-2325

### PORTUGAL

Omron Electronics LDA  
Edificio Omron  
Rue de Sao Tome, Lote 131  
Prior Velho, Portugal 2685  
Phone: 351-1-941-7599  
Fax: 351-1-941-7890

### RUSSIA (CIS)

Omron Electronics  
Brigadiersky Pereulok 6  
Moscow, Russia 107 005  
Phone: 7-0-95-265-90-25  
Fax: 7-0-95-261-42-16

### SPAIN

Omron Electronics, S.A.  
Calle Arturo Soria 95  
Madrid, Spain, E-28027  
Phone: 34-1-3-77-9000  
Fax: 34-1-3-77-9037

### SWEDEN

Omron Electronics A.B.  
Norgegatan 1  
Kista, Sweden S-164 28  
Phone: 46-8-632-35-00  
Fax: 46-8-632-35-10

## SWITZERLAND

Omron Electronics A.G.  
Gwerbestrassse 7  
Cham, Switzerland 6330  
Phone: 41-42-431-313  
Fax: 41-42-431-345

## TURKEY

Omron Electronics Ltd.  
Acibadem Caddesi  
Palmiye Sokak 12  
Kadikoy-Istanbul, Turkey, TR 81020  
Phone: 90-216-326-2980/2981/2982  
Fax: 90-216-326-2979

## U.K.

Omron Electronics Ltd.  
1 Apsley Way  
Staples Corner, London NW2 7HF  
England  
Phone: 44-181-450-4646  
Fax: 44-181-450-8087

## MIDDLE EAST & AFRICA

### BAHRAIN

Ebrahim Al-Shakar & Sons  
P.O. Box 5344  
Manama, Bahrain  
Phone: 973-255472/251160  
Fax: 973-277894

### EGYPT

Union  
19 Gezirat Al Arab Str.  
Al Mohandeseen, Giza, Egypt  
Phone: 202-3497808  
Fax: 202-3490864

### IRAN

Control Sazeh Co. Ltd.  
P.O. Box 15855-354  
Karimkhan Zand Ave. No. 191  
3rd Floor No. 33  
Tehran, Iran  
Phone: 9821-8801340  
Fax: 9821-8890436

### ISRAEL

Ateka Ltd.  
23 Hayetzira Street P.O. Box 3120  
Kyriat Aryeh, Petach-Tikva, Israel 49512  
Phone: 9732-939-2333  
Fax: 9723-924-3273

### JORDAN

Gedco  
Fawzi Al-Muliqi 4th Circle  
Beside the Moroccan Embassy  
Amman, Jordan  
Phone: 962-6-641607  
Fax: 962-6-642547

### KENYA

Switchgear & Controls, Ltd.  
P.O. Box 42503  
Nairobi, Kenya 19865  
Phone: 254-2-540381  
Fax: 254-2-544788

### KUWAIT

Ammar & Partners Electrical Co.  
P.O. Box 1871  
Safat, Kuwait 13019  
Phone: 965-48301222  
Fax: 964-4841818

## SAUDI ARABIA

Tayseer Al-Sheikh Corporation  
Prince Majed Street  
P.O. Box 19865  
Jeddah, Saudi Arabia 21445  
Phone: 966-2-6717285  
Fax: 966-2-6731910

## SOUTH AFRICA

Yelland Control  
P.O. Box 10993  
Johannesburg, South Africa  
Phone: 2711-824-3460  
Fax: 2711-827-9861

## SYRIA

Ohaara Data Engineering  
Surian Djadideh, Zuhour P.O. Box 4410  
Aleppo, Syria  
Phone: 963-21-219449  
Fax: 963-21-244733

## TUNISIA

Axafrica  
10 Avenue Habib Bourguiba  
Tunis, Tunisia 1001  
Phone: 216-1-344-103  
Fax: 216-1-343-527

## UNITED ARAB EMIRATES

Deira General Marketing  
P.O. Box 11370,  
Dubai, U.A.E.  
Phone: 9714-624111  
Fax: 9714-213942

## OCEANIA & ASIA

### AUSTRALIA

Omron Electronics Pty. Ltd.  
Omron House  
71 Epping Road  
Locked Bag No. 18  
North Ryde, Sydney  
New South Wales 2113, Australia  
Phone: 61-2-9878-6377  
Fax: 61-2-9878-6981

### CHINA

Omron China Co. Ltd.  
5/F Chang Fu Gong Office Bldg.  
A26 Jian Guo Men Wai Da Jie  
Chao Yang District, Beijing, China  
Phone: 86-10-513-0674  
Fax: 86-10-513-9236

### HONG KONG

Omron Electronics Asia Ltd.  
Unit 601-9 The Gateway, Tower 2  
25 Canton Road  
Tsimshatsui, Kowloon, Hong Kong  
Phone: 852-2375-3827  
Fax: 852-2375-1475

### INDONESIA

Omron Asia Pacific PTE Ltd.  
Indonesia Representative Office  
Danamon Aetna Life Tower, Ste. 1602  
JL Jend. Sudirman Kav 45-46  
Jakarta 12930, Indonesia  
Phone: 62-21-577-0838  
Fax: 62-21-577-0840

## JAPAN

Omron Corporation  
FA Division H.Q.  
14F Nissei Building  
1-6-3 Osaki  
Shinagawa-ku Tokyo  
Phone: 03-3779-9038  
Fax: 03-3779-9041

## KOREA

Omron Korea Co. Ltd.  
3F New Seoul Bldg.#618-3  
Sin Sa-Dong  
Kang Nam-Gu, Seoul, Korea  
Phone: 82-2-511-8071  
Fax: 82-2-512-0874

## MALAYSIA

Omron Electronics Sales & Service  
(M) SDN BHD  
10th Floor Block B Menara PKNS-PJ  
No. 17 Jalan Yong Shook Lin  
46050 Petaling Jaya  
Selangor Darul Ehsan, Malaysia  
Phone: 03-7547323  
Fax: 03-7546618

## NEW ZEALAND

Omron Electronics Ltd.  
65 Boston Road  
Private Bag 92620  
Symonds Street, Auckland, New Zealand  
Phone: 09-3584400  
Fax: 09-3584411

## SINGAPORE

Omron Asia Pacific PTE Ltd.  
139 Joo Seng Road  
#04-01 ATD Centre  
Singapore 368362  
Phone: 65-2830006  
Fax: 65-2850682  
Telex: RS 23403

## TAIWAN

Omron Taiwan Electronics Inc.  
6F, Home Young Bldg., No. 363  
Fu-Shing N. Road  
Taipei, Taiwan, R.O.C.  
Phone: 886-2-7153331  
Fax: 886-2-7126712

## THAILAND

Omron Electronics Co. Ltd.  
Rasa Tower, 20th Floor  
555 Phaholyothin Road  
Chatuchak, Bangkok 10900, Thailand  
Phone: 02-9370500  
Fax: 02-9370501

## VIETNAM

Omron Asia Pacific PTE Ltd.  
Hanoi Representative Office  
104 Tran Hung Dao Street  
RM 2.4.A. Hanoi, Vietnam  
Phone: 04-8221273 \ 8221294  
Fax: 04-8221278

Omron's global sales and technical support network helps you maintain imported equipment with Omron controls, and lets you confidently ship machinery with Omron control systems anywhere in the world.

The organizations listed here do not include the local distributors in each region. Please phone or fax the main office for additional information.