

Supply Module TVM 2.4

Applications Manual

DOK-POWER*-TVM*2.4****-ANW1-EN-P



262877

Title	Supply Module TVM 2.4
Type of documentation	Applications
Document code	DOK-POWER*-TVM*2.4****-ANW1-EN-E1,44
Replaces	First edition
Internal file reference	<ul style="list-style-type: none"> • Mapped 6 • TVM24_AN.pdf • 209-0049-4302-01
Reference	This electronic document is based on the hardcopy document with document design.: DOK-POWER*-TVM*2.4****-ANW1-EN-P
The purpose of this document	<p>In this document you will find:</p> <ul style="list-style-type: none"> • the applications, • the electrical lay-out, • the mechanical lay-out of the control cabinet, • assembly and installation guidelines, • guidelines for selecting optional components and, • fault clearance guidelines.

Document designation of previous editions	Status	Comments
209-0049-4302-00 EN/09.94	Sep./94	1st release
DOK-POWER*-TVM*2.4****-ANW1-EN-P	Aug./96	Revision of doc/intro. of type
DOK-POWER*-TVM*2.4****-ANW1-EN-E1,44	Mai/97	Revision of E-Dok

Copyright © INDRAMAT GmbH, 1994
 Copying of this document, and giving it to others and the use or communication of the contents thereof, are forbidden without express authority. Offenders are liable to the payment of damages.
 All rights are reserved in the event of the grant of a patent or the registration of a utility model or design. (DIN 34-1)

The electronic documentation (E-doc) may be copied as often as needed if such are to be used by the consumer for the purpose intended.

Validity All rights reserved with respect to the content of this documentation and the availability of the products.

Publisher INDRAMAT GmbH • Bgm.-Dr.-Nebel-Straße 2 • D-97816 Lohr
 Telefon 0 93 52 / 40-0 • Tx 689421 • Fax 0 93 52 / 40-48 85

Dept ENA (DE, VS, FS)

Table of Contents

	Page
1. Installing INDRAMAT'S modular AC drive system	7
1.1. The main functions of the TVM 2.4 supply module	8
2. Applications	9
2.1. Power ratings	10
2.2. TVM 2.4 dimensional data	11
2.3. Ambient conditions	12
2.4. Functional power features	13
3. Electrical connections - installation guidelines	14
3.1. Terminal diagram	15
3.2. Mains connection - power section	16
3.3. Fuse protection for the power connection	19
3.4. Selecting the mains contactor	21
3.5. Power supply requirements	22
3.6. D.C. bus	23
3.7. Additional capacitance on the D.C. bus	23
3.8. Additional bleeder	24
3.9. AC Input power for electronics and blowers	25
3.10. Wire ribbon connection for the electronics	26
3.11. Fault current protective device	27
3.12. Checking the control cabinet	27
3.13. Installing the TVM 2.4	28
3.14. Safety clearances	29
3.15. Heat loss within the control enclosure	29
3.16. Front view of the TVM 2.4	30
4. Control circuits (control of input power)	31
4.1. Possible error reactions	31
4.2. Recommended error reactions	32

4.3. DC bus short-circuiting switch.....	34
4.4. Control circuit without soft-start resistor with dynamic braking.....	36
4.5. Control circuits with soft-start resistors, for applications with TDM drive modules	38
4.6. Control circuit with soft-start resistor, for applications with DDS drive controllers	40
5. Interface descriptions	42
5.1. Signal voltages	42
5.2. Ready signal	42
5.3. Additional bleeder control	43
6. Trouble-shooting guides	44
6.1. Troubleshooting	44
6.2. Safety guidelines	44
6.3. Diagnostics displays	46
6.4. List of faults and their remedies	47
6.5. Fuses	48
7. Dimensional data	49
7.1. TVM 2.4 supply module - dimensional data	49
7.2. Dimensions for DST autotransformers.....	50
7.3. Dimensions for DLT isolation transformers	51
7.4. Dimensions additional capacitor CZ 1.02	52
7.5. Dimensions additional capacitor TCM 1.1	52
7.6. Dimensions for bleeder module TBM 1.2	53
7.7. Dynamic brake contactor	54
7.8. Dynamic brake resistor	54
7.9. Soft-start resistor	55
7.10. Single-phase transformer	55

8. Order information	56
8.1. TVM 2.4 type codes	56
8.2. Available configurations of supply module TVM 2.4 and accessories	56
8.3. Available autotransformers	57
8.4. Available isolation transformers	58
8.5. Overview of electrical accessories	60
8.6. Order list for TVM 2.4 power supply module	60
9. Index	61

1. Installing INDRAMAT'S modular AC drive system

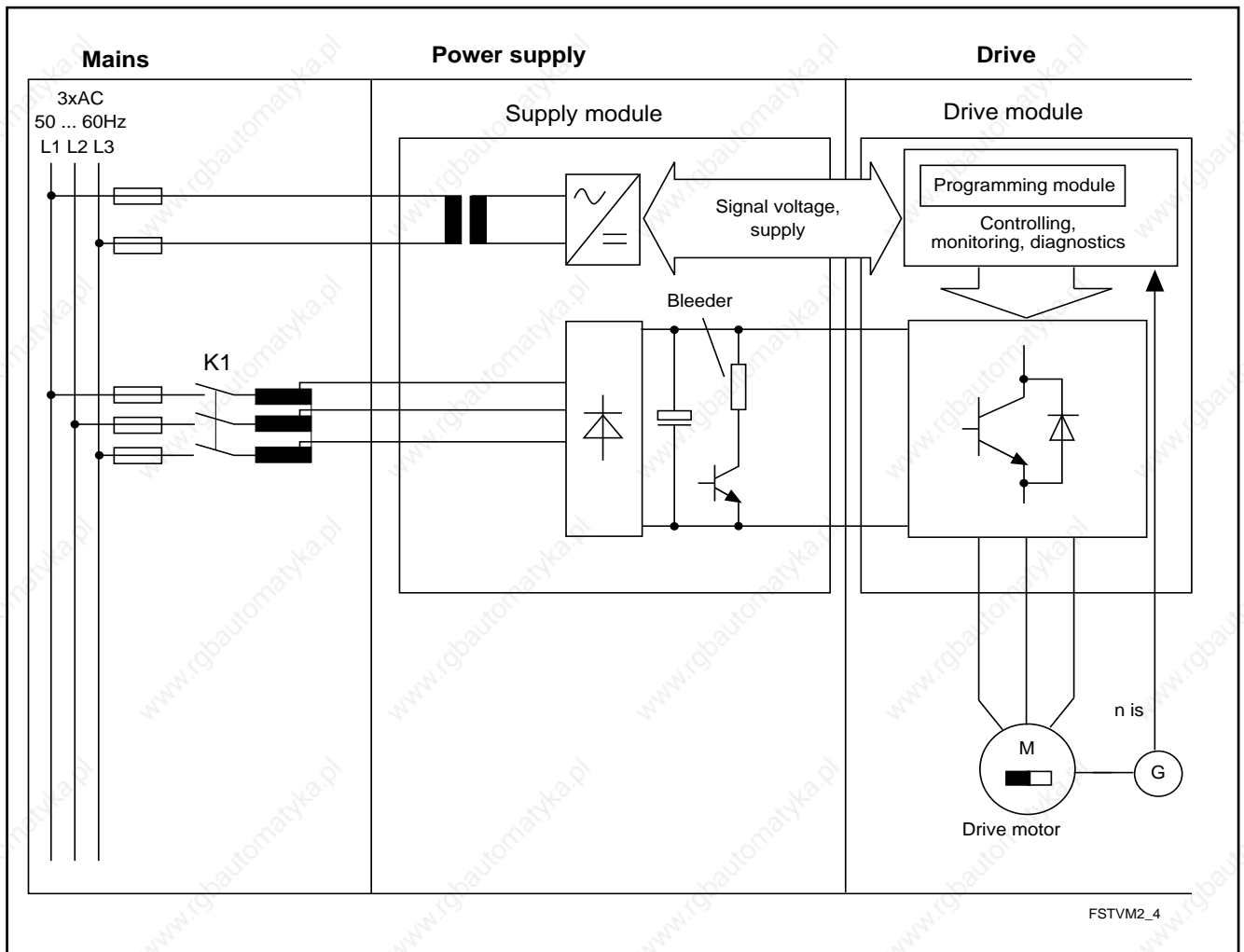

Figure 1.1: The TVM 2.4 supply module as a part of Indramat's A.C. drive system

INDRAMAT's A.C. drive system is made up of one supply module and the drive modules. Several drives can be run from one supply module. The TVM 2.4 supply module is a component part of INDRAMAT's ac modular drive system.

The TVM 2.4 supply module provides the d.c. high voltage for the motor power and the control voltages for all connected INDRAMAT drive.

1.1. The main functions of the TVM 2.4 supply module

Power supply to drives The power rectifier of the TVM 2.4 rectifies the three-phase mains A.C. voltage and provides the D.C. high voltage for the drives.

When the drives are in generator mode, the regenerated power is absorbed by the bleeder resistor in the TVM 2.4.

The buffer capacitance provides sufficient smoothing.

Power supply to the electronics The TVM 2.4 supplies the electronics of the drive module via the wire ribbon cable.

Monitoring the drive system The TVM 2.4 is equipped with extensive monitoring functions. These communicate with the drive modules via the signal bus voltage.

The Bb1 contact of the TVM 2.4 is very important to drive system readiness. Power can only be switched on when this contact is closed.

2. Applications

It is possible to operate INDRAMAT's TVM 2.4 series of supply modules with a continuous mechanical output of 4.1 kW. For this reason, it is the preferred power supply for servo drives.

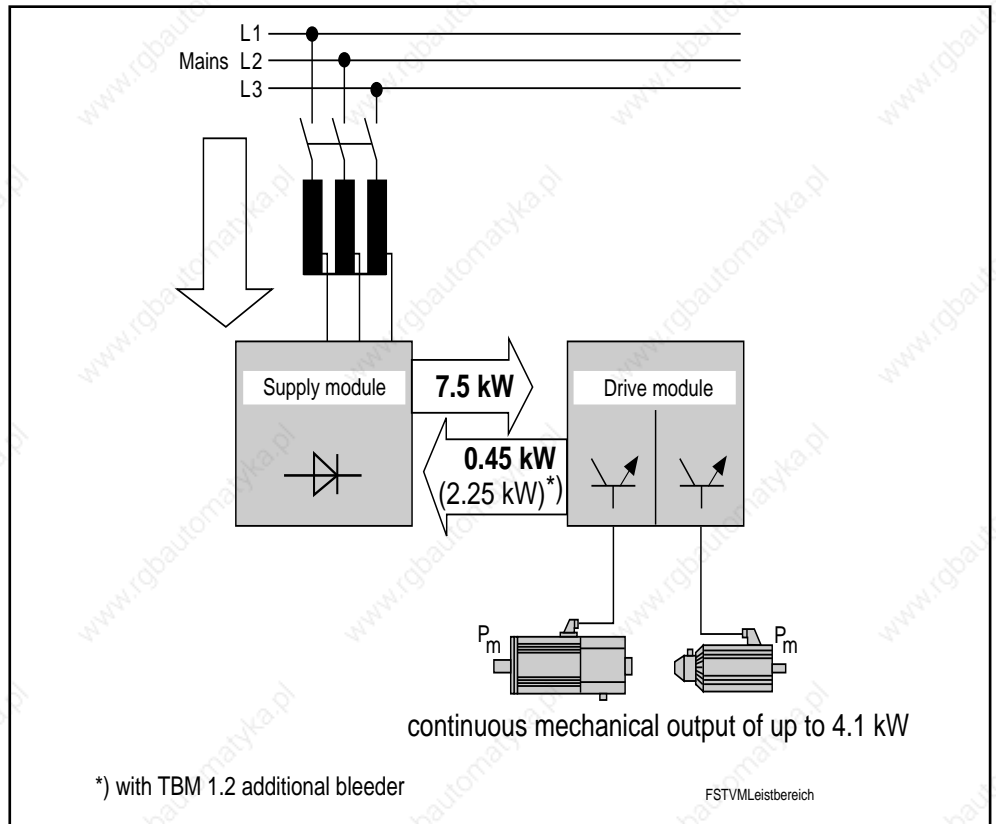

Figure 2.1: The power range of the TVM 2.4 supply module

2.1. Power ratings

With the use of additional components, it is possible to optimize the usable power of the TVM 2.4 to meet the requirements of the respective application.

(1)	(2)	(3)	(4)	(5)	(6)	(7)	(8)	Mains supply module TVM 2.4-050-220/300-W1/.../... + accessories	
$\frac{P_{DC}}{kW}$	$\frac{P_{KB-3}}{kW}$	$\frac{P_{KB-03}}{kW}$	$\frac{P_{BD}}{kW}$	$\frac{P_{BM}}{kW}$	$\frac{W_{max}}{kWs}$	$\frac{P_m}{kW}$	$\frac{P_{mKB-03}}{kW}$	Additional bleeder	Transformer
2.4	5.5	11	0.45	10	14	1.3	6.1		2.5 kVA
			2.25	50	114			TBM 1.2-40-W1-024	
3.8	10	20	0.45	10	14	2.1	11.1		4 kVA
			2.25	50	114			TBM 1.2-40-W1-024	
4.8	14	28	0.45	10	14	2.6	15.6		5 kVA
			2.25	50	114			TBM 1.2-40-W1-024	
7.1	20	42	0.45	10	14	4.0	23.3		7.5 kVA
			2.25	50	114			TBM 1.2-40-W1-024	
7.5	20	60	0.45	10	14	4.1	33.3		10 kVA
			2.25	50	114			TBM1.2-40-W1-024	
(1) P_{DC}		= Continuous D.C. bus power		(5) P_{BM}		= Peak bleeder power			
(2) P_{KB-3}		= D.C. bus short-time power for 3s (accelerating main drives)		(6) W_{max}		= Maximum regenerated energy			
(3) P_{KB-03}		= D.C. bus peak power for 0.3s (accelerating servo drives)		(7) P_m		= Continuous mechanical power			
(4) P_{BD}		= Continuous bleeder power		(8) P_{mKB-03}		= Peak mechanical power for 0.3s (accelerating servo drives)			

Figure 2.2: Selection data

2.2. TVM 2.4 dimensional data

Designation	Symbol	Unit	TVM 2.4-50-220/300-W1/.../...
Power section			
Input voltage	U(ACN)	(V)	3 x 220V (+15/-10%) or 3 x 230 V (+10/-15%)
Frequency	f(N)	(Hz)	50 ...60
D.C. bus d.c. voltage	U(DC)	(V)	300 (± 15%)
D.C. bus continuous power	P(DC)	(kW)	7.5
D.C. bus peak power	P(KB-03)	(kW)	60
Continuous bleeder power	P(BD)	(kW)	0.45
Peak bleeder power	P(BM)	(kW)	10
Maximum regenerated power	W(max)	(kWs)	14
Power loss (at maximum load without bleeder losses)	P(v)	(W)	130
Weights	m	(kg)	15
Supply to electronics			
Input voltage	U(AC)	(V)	230/400 (+10/-15%) or 115/230 (±10%)
Frequency	f(N)	(Hz)	50 ... 60
Power consumption at maximum load	S(el)	(VA)	550
Control voltage output			
+ 24V load voltage	U(L)	(V)	24 ... 30
+ 24VL continous current	I(UL)	(A)	8
+ 24VL ripple		(%)	10
± 15V measuring voltage	U(M)	(V)	14.9 ... 15.1
+ 15VM continuous current	I(+UM)	(A)	1.3
- 15VM continuous current	I(-UM)	(A)	1.0
± 15VM ripple		(%)	0.1
Ambient conditions			
Permissible ambient temperature with rated data	T(um)	(°C)	+5 ... +45
Maximum ambient temperature for derated output	T(umr)	(°C)	55
Storage and transportation temperature	T(L)	(°C)	-30 ... +85
Installation altitude without reduction of rated data			maximum 1000 meters above sea level
Humidity class			F per DIN 40 040
Insulation class			C per DIN VDE 0110
Protection category			IP 10 per DIN 40 050

Figure 2.3: TVM 2.4 supply module - technical data

2.3. Ambient conditions

Increased ambient temperature

The ratings and loads of the control voltages listed in the TVM 2.4 data sheets are valid within an ambient temperature range of +5 to 45° C. Maximum permissible ambient temperature can equal up to +55° C. The reduction in power ratings is depicted in the following diagram.

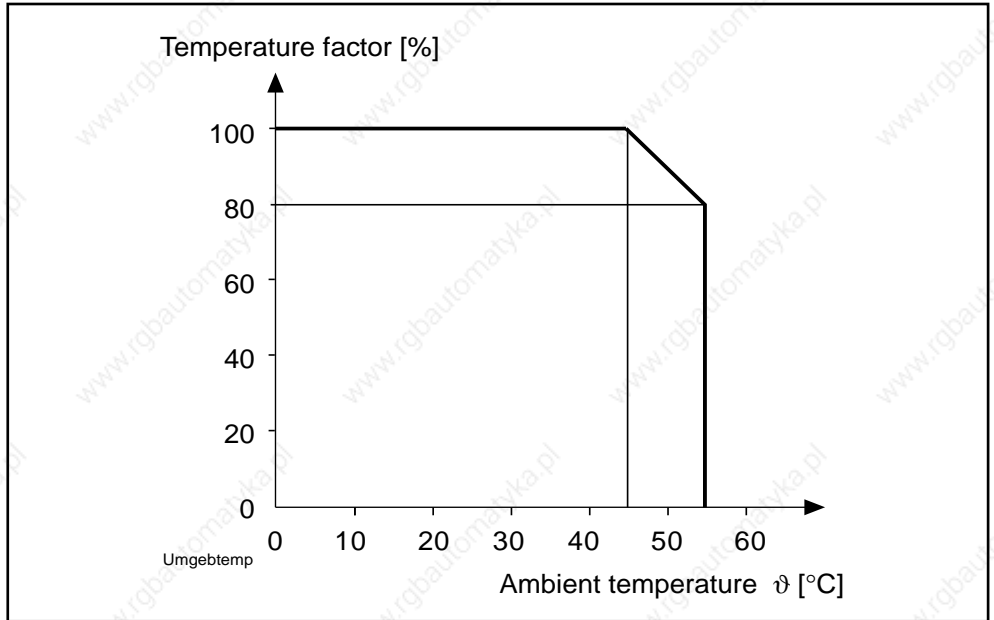

Figure 2.4: Reduction in power ratings with increased ambient temperature

Installation altitude above 1000 m

The TVM's power ratings drop as per the following diagram when installation altitude exceeds 1000 meters above sea level.

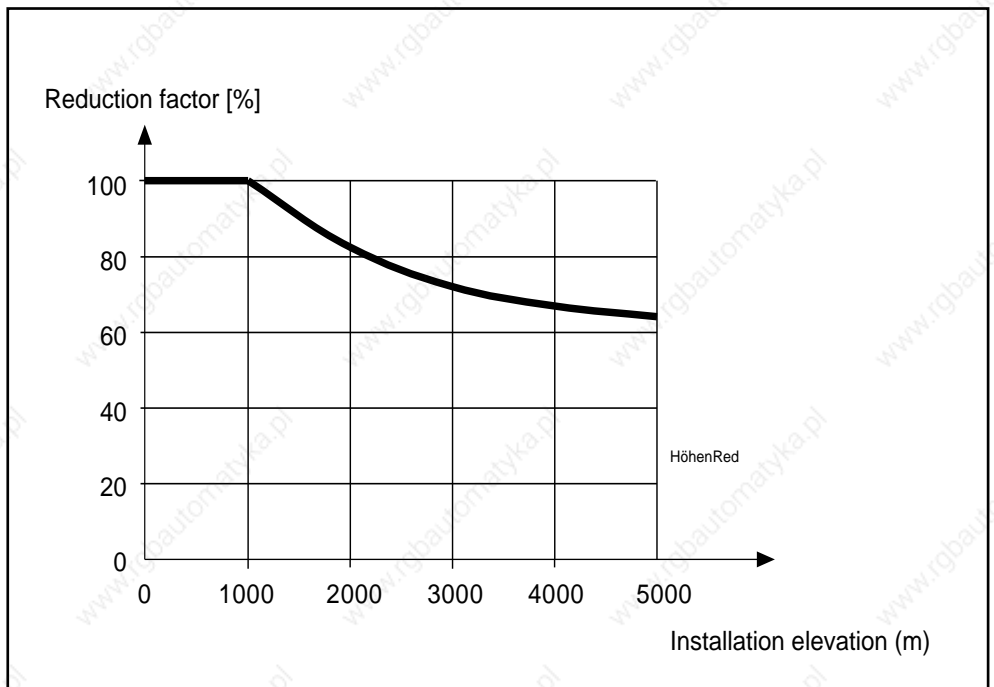

Figure 2.5: Reduction in power ratings for installation altitudes above 1000 meters

2.4. Functional power features

- **Simple and problem-free voltage matching**

In most cases, an autotransformer can be used to adapt the mains voltage to the connection voltage.

- **Fuse protection with the use of circuit breakers**

- expensive semi-conductor fuses are not required,
- and, no special fuses are needed if the unit is exported.

- **Using additional capacitance means drive energy can be stored**

Heat losses and energy consumption are minimized, if the energy created during braking is stored in the additional capacitance.

- **Braking synchronous drives to standstill in the event of mains failure or problems in the drive's electronics**

The drive can be braked to standstill in the event of a malfunction by the dynamic brake.

- **High load capabilities of the control voltage**

The high load capabilities of the control voltage make it possible to connect six or more drives to one supply module.

- **Monitoring all drive components**

The ready contact of the TVM 2.4 immediately switches power off in the event of a malfunction.

- **Ease of servicing**

The TVM 2.4 uses LED displays to make fault finding and clearance easy.

- **UL-Approval**

A more simplified machine inspection, if UL approval is required.

3. Electrical connections - installation guidelines



The TVM's terminal connection diagram as shown in this document is a recommendation of the unit manufacturer. The circuit diagrams of the machine builder must be used for installation.

3.1. Terminal diagram

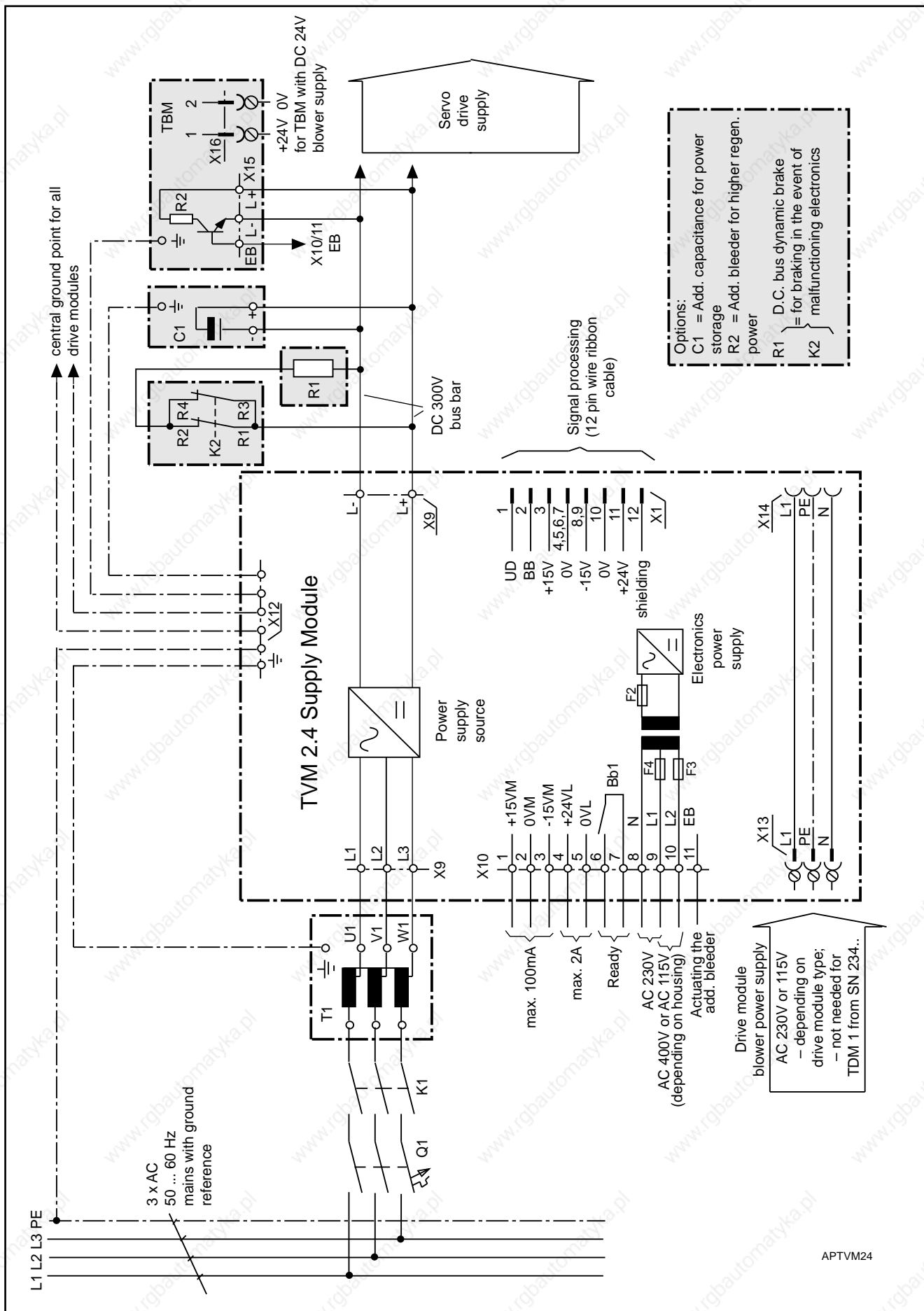

Figure 3.1: TVM 2.4 supply module terminal diagram

Mains connection using a transformer - with soft-start resistor

Soft-start resistors are used to limit the inrush current where the transformer power is greater than 10 kVA or 2.5 kVA, and with additional capacitors.



DANGER

The DC bus short-circuit resistor is not secured against accidental contact. There is the danger of high-voltages (greater than 50 V).

Electrical shock resulting from contact

==> use an appropriate cover, see that it is in place or properly mounted



CAUTION

Thermal damage caused by DC bus short-circuit contactor and resistor in the event of faults in the control or contactor is possible.

Damage or loss due to fire is possible inside the control cabinet.

==> use an appropriate cover, see that it is in place or properly mounted

(See Fig. 4.1, recommended cover for the DC bus short-circuit switch)

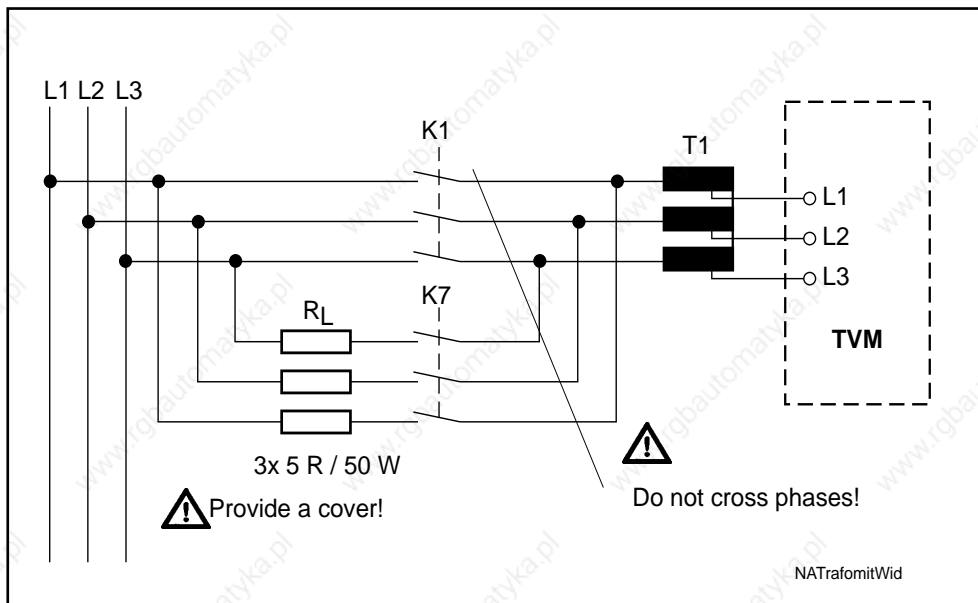

Figure 3.3: Power connections on the primary side of the transformer with soft-start resistors

Direct connection to the mains

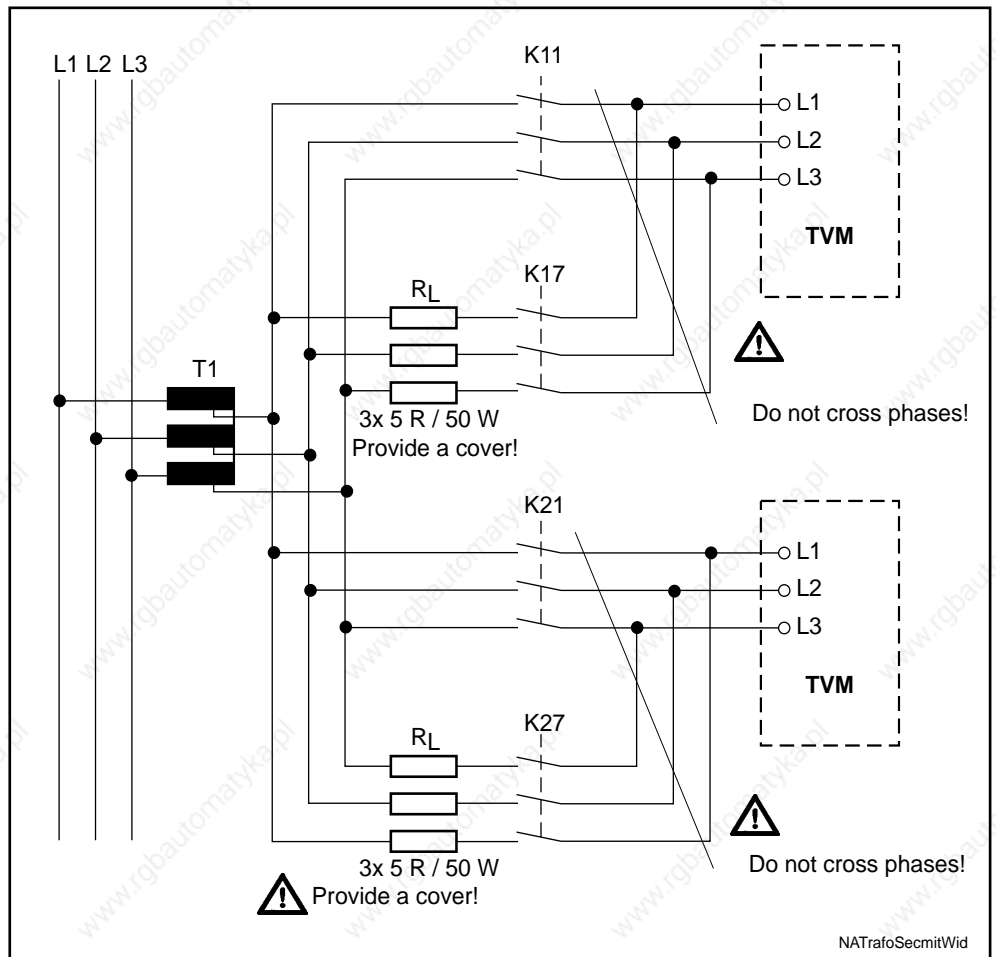

Figure 3.4: Power connections on the transformer secondary side with soft-start resistors

The TVM 2.4 can be directly connected to 3 x AC 220 V. There is no need for a transformer. Soft-start resistors are needed to limit the inrush current.

3.3. Fuse protection for the power connection

The TVM mains connection can be protected with the use of either circuit breakers or gL classification (slow-blow) fuses. The protective device is generally placed on the primary side of the transformer. Do not select conductor cross sections smaller than the recommendations in the following tables, especially for low power isolation transformers. Otherwise, short-circuit protection of the secondary will be compromised.

Maximum permissible fusing

Fuses on the primary side of the transformer

The fuse or circuit breaker rating (gL) must not exceed:

- 3 x AC 460 V, $I_N = 25$ A;
- 3 x AC 525 V, $I_N = 20$ A

Fuses on the secondary side of the transformer or for 3 x A. 220 V mains

- $I_N = 35$ A.

Safety fuses

The safety fuses can be selected per the following recommendations, if INDRAMAT transformers are used, and connections are made as outlined in section 3.1.

Power circuit breakers

Using power circuit breakers has the advantage that faulty operation with two phases is generally not possible. The following recommendations apply when selecting power circuit breakers where INDRAMAT transformers are used and connections are per section 3.1.

Selecting the power circuit breakers and fuses for the following conditions:

- connection voltage 3x AC 400 V
- without additional capacitance on the D.C. bus, or if soft-start resistors are used

Transformer power in kVA	Connection cross sections in mm ² 2)		Rated current in A		Recommended safety fuses (class gL*)	Power circuit breakers Siemens: Series 3VU 1)	Setting range in A	Setting value in A
	primary	secondary	primary	secondary				
2.0	1.5	1.5 (4)	2.9	5	6 A slow-blow	3VU1300-•MK00	4 ... 6	4
2.5	1.5	1.5 (4)	3.6	6.3	10 A slow-blow	3VU1300-•ML00	6 ... 10	6
3.5	1.5	1.5 (6)	5.1	8.8	16 A slow-blow	3VU1300-•MM00	10 ... 16	10
4.0	1.5	1.5 (6)	5.8	10	16 A slow-blow	3VU1300-•MM00	10 ... 16	10
5.0	1.5	1.5 (6)	7.2	12.6	20 A slow-blow	3VU1300-•MN00	14 ... 20	14
7.5	1.5	4	10.8	18.8	20 A slow-blow	3VU1300-•MP00	18 ... 25	18
10	2.5	6	14.5	25.1	20 A slow-blow	3VU1300-•MP00	18 ... 25	18

1) Note maximum backup fuse as per manufacturer recommendations!

2) Cable cross section per EN 60204 - type B1 - without regard for correction factors. Values in brackets apply to the use of DLT type isolation transformers.

* gL = cable and conductor protection

Selecting the power circuit breakers and fuses for the following conditions:

- connection voltage 3x AC 400 V
- with additional capacitance (to 16 mF) and transformer power of ≤ 2.5 kVA

Transformer power in kVA	Connection cross sections in mm ² 2)		Rated current in A		Recommended safety fuses (class. gL)	Power circuit breakers Siemens: Series 3VU 1)	Setting range in A	Setting value in A
	primary	secondary	primary	secondary				
2,0	1.5	1.5 (4)	2.9	5	16 A slow-blow	3VU1300-•ML00	6 ... 10	6
2.5	1.5	1.5 (4)	3.6	6.3	16 A slow-blow	3VU1300-•MM00	10 ... 16	10

- 1) Maximum fuse sizing as per manufacturer recommendations!
- 2) Conductor cross section per EN 60204 - installation type B1 - without taking correction factors into consideration. Values in brackets apply to the use of DLT type isolation transformers.

3.4. Selecting the mains contactor

Do not select the mains contactor smaller than is recommended in the following table because of the inrush current. If smaller mains contactors are used, the contacts may be fused together.

Without soft-start The following recommendations apply to mains 3 x 400 V:

- mains disconnect on the primary side of the matching transformer
- without soft-start resistor

Transformer kVA	Additional capacitance	Peak inrush current in A	Mains contactor Siemens 3TF type
2.0	---	230	3TF 44
2.0	max. 8 mF	270	3TF 44
2.5	---	260	3TF 44
2.5	max. 8 mF	330	3TF 46
3.5	---	320	3TF 46
4.0	---	340	3TF 46
5.0	---	400	3TF 47
7.5	---	470	3TF 47
10	---	500	3TF 47

With soft-start The following recommendations apply to mains 3 x 400 V:

- connecting the mains to the primary side of the matching transformer, and,
- with soft-start resistor.

The mains contactor can be sized according to the rated current of the transformer. Do not select the rated current of the mains contactor, per user category AC 3, smaller than 32 A (typical AC 3 application = switching a squirrel cage motor).

Do not select the rated current of the charging contactor, per user category AC 3, smaller than 16A.

Transformer power in kVA	Remaining peak inrush current in A (peak value)	Mains contactor Siemens: 3TF type	Charging contactor Siemens: 3TF type
2.0 ... 20	200	3TF 44	3TF 42
25	200	3TF 45	3TF 42
35	200	3TF 47	3TF 42

*Connecting voltage is
not 3 x 400 V*

For connection to voltages other than 3 x 400 V, or if the mains contactor is installed on the secondary side of the transformer, the contactor sizing can be determined with the following relation:

$$I_{AC3} = \frac{400V}{U_N} \times \frac{i_{peak}}{6 \times \sqrt{2}}$$

I_{AC3} = rated current per use category AC 3

i_{peak} = peak inrush current in A per above table

U_N = connection voltage in V

3.5. Power supply requirements

Grounded mains

Voltages can be adapted with an autotransformer for grounded mains systems, either star systems with a grounded neutral or system with a grounded phase (TN or TT mains). It is possible to directly connect the TVM 2.4 to 3 x AC 200 V mains .

Ungrounded mains

There is the increased danger in ungrounded mains (IT-mains) that overvoltages can occur between the phases and the housing. The TVM 2.4 can only be operated with such systems if:

- the TVM 2.4 is connected across an isolation transformer, or,
- the installation is protected with an overvoltage conductor.

Connecting the TVM 2.4 via an isolation transformer offers the best protection against overvoltage and the greatest possible operating safety.

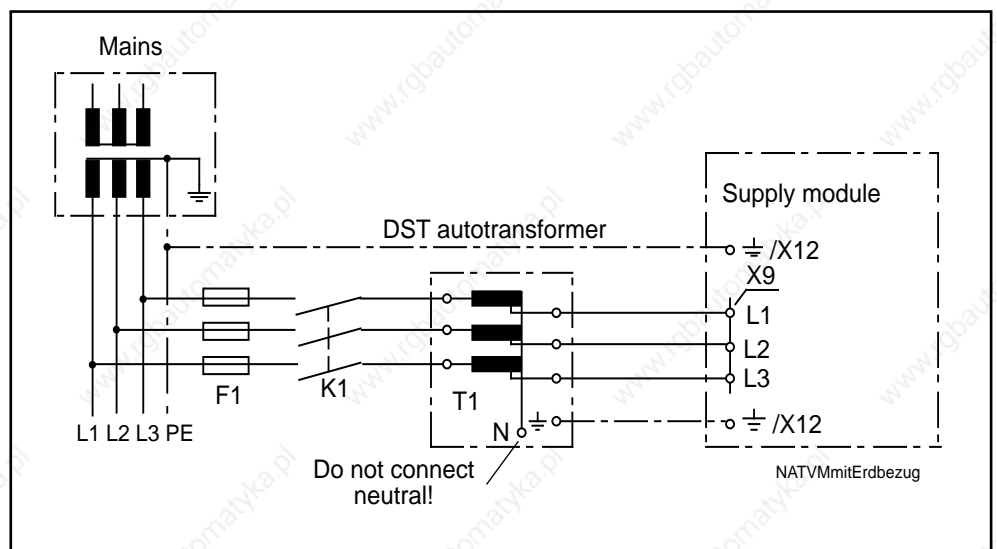

Figure 3.5: Connecting the TVM 2.4 to a grounded power system

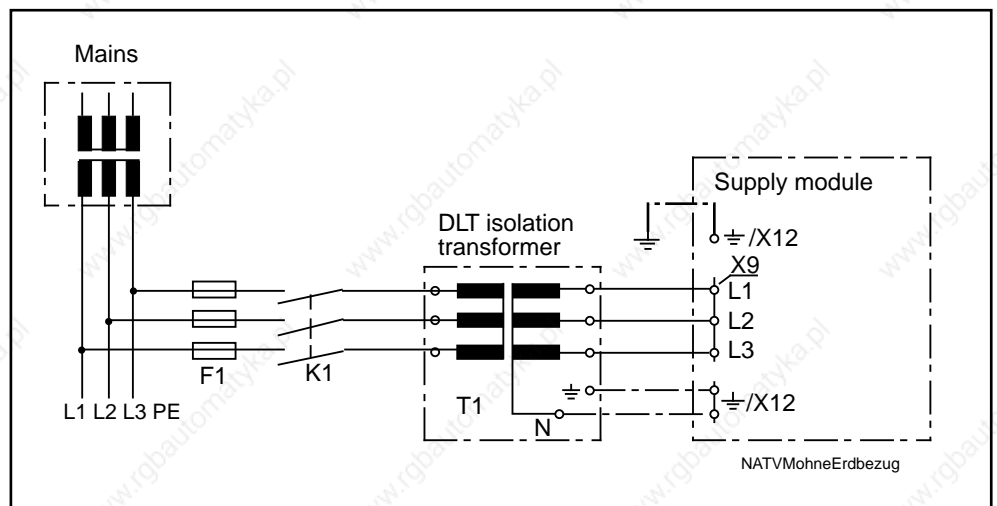

Figure 3.6: Connecting the TVM 2.4 to an ungrounded power system

3.6. D.C. bus

Use the busbars found in the connection accessories of the drive module to connect the drive modules to the d.c. bus.

Use individual cables with stranded wires for longer connections (maximum length of one meter).

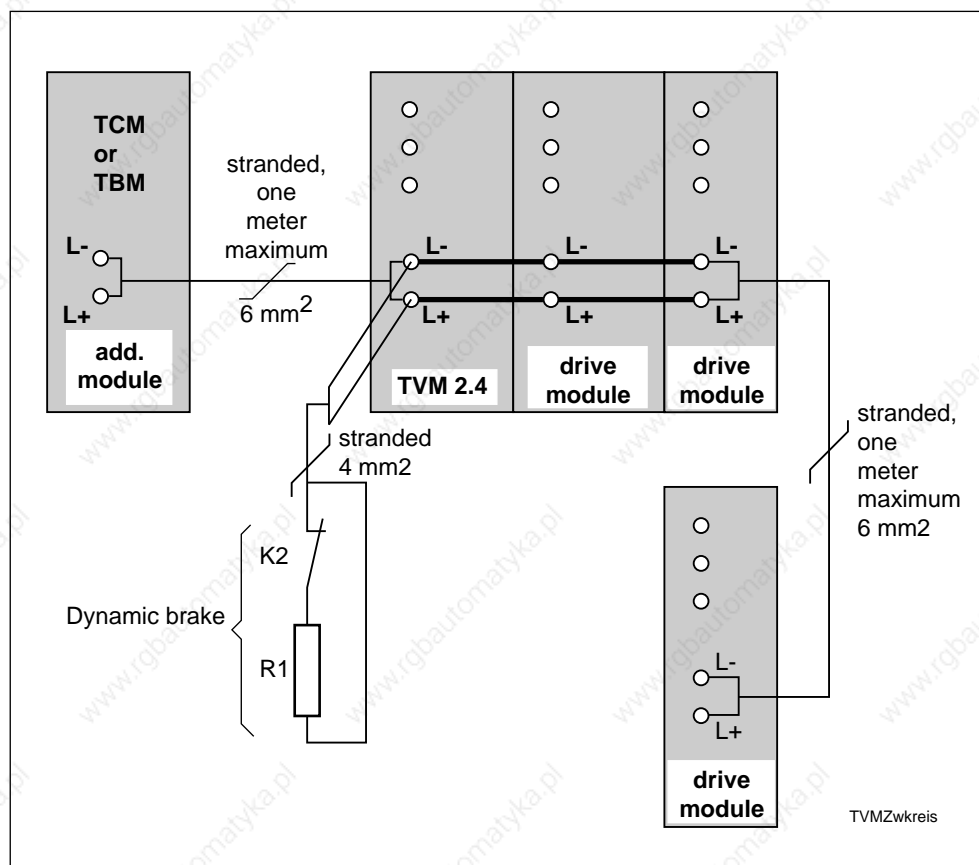

Figure 3.7: Wiring the D.C. bus



During normal operation, the dynamic brake resistor R1 has DC 150 V applied to it with respect to ground. The cabinet builder must provide protection against accidental contact (e.g., with the use of plexiglass).

3.7. Additional capacitance on the D.C. bus

Additional capacitance modules can be connected to the D.C. bus for energy storage. When the drives are decelerated, the drive energy is stored and can be used for acceleration. This means that both the heat lost within the control cabinet and energy consumption are minimized. Approximately 30 watt-sec. can be stored for each mF of additional capacitance.

Soft-start resistors are needed if additional capacitance is used and the transformer for high-voltage power is larger than 2.5 kVA (see section 3.2).

3.8. Additional bleeder

The TBM 1.2 additional bleeder module can be installed to increase continuous and peak regenerated power. The following power ratings can be achieved by combining the TVM 2.4 and the TBM 1.2.

Continuous bleeder power (continuous regenerated power)	Peak bleeder power (peak regenerated power)	Maximum regenerated power
2.25 kW	50 kW	114 kW

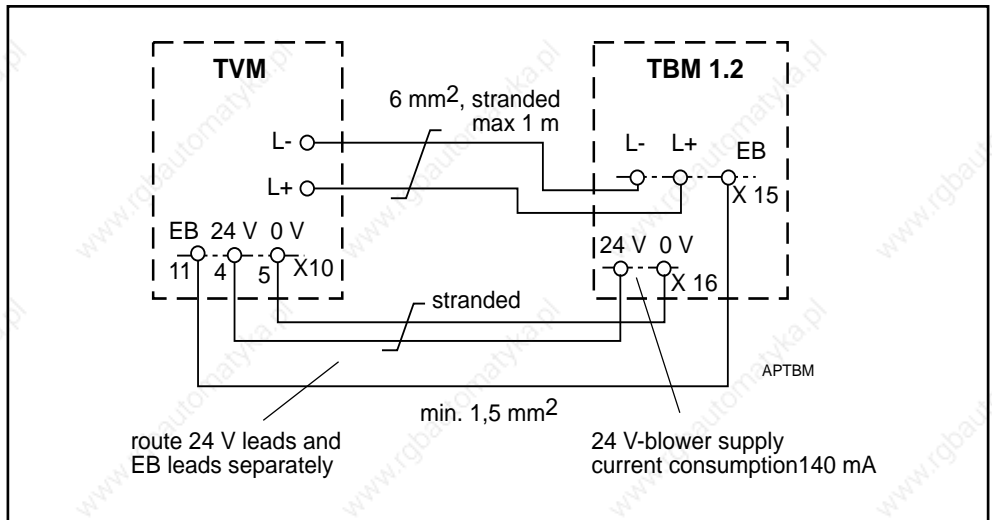

Figure 3.8: Connecting the TBM 1.2 additional bleeder module

3.9. AC Input power for electronics and blowers

Electronic power supply

Connector: X 10 /8/9/10

Maximum connection diameter: 2.5 mm²

Input voltage: depends on unit

AC 115/230 V or AC 230/400 V, 50...60Hz

Power consumption: 550 VA

(when electronic supply is at maximum load)

Back-up fuse:

The disconnect switch can be installed with line fuses or circuit breakers.

Connection voltage	Safety fuses utilization gL	Power circuit breakers (tripping characteristics C)
115/230 V	10 A slow-blow	10 A
230/400 V	10/6 A slow-blow	10/6 A

Blower supply voltage

Connector X 13 is located on the bottom of the TVM. The voltage can be jumpered from there to the drive module with the use of a ready-made cable.

For drive modules of the newer series (TDM 1.2-...-300-W1-**000**, TDA, DDS 2 and the TVM 2.4 itself), the blower is supplied through the wire ribbon cable from the electronic power supply. These drive modules **do not** require an external blower voltage source. X13 remains unused.

Only in those cases where a TDM 1.2-...-300-W1-**220**, TDM 1.2-...-300-W1-**115**, KDA, KDS, KDF, or a TFM are used, connect AC 115 V or 230 V to X13, depending on the type of blower used.

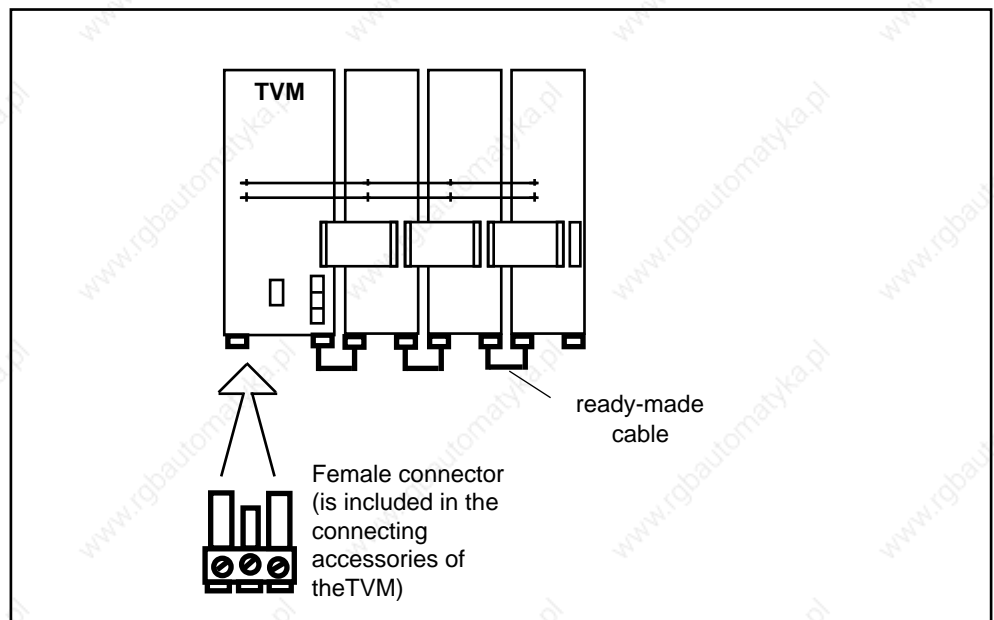

Figure 3.9: Drive module blower supply

3.10. Wire ribbon connection for the electronics

The wire ribbon connection X1 has two functions:

- supplying power to the drive electronics, and,
- signal exchange between the supply and drive modules.

The wire ribbon cable is included in the connecting accessories of the drive module.

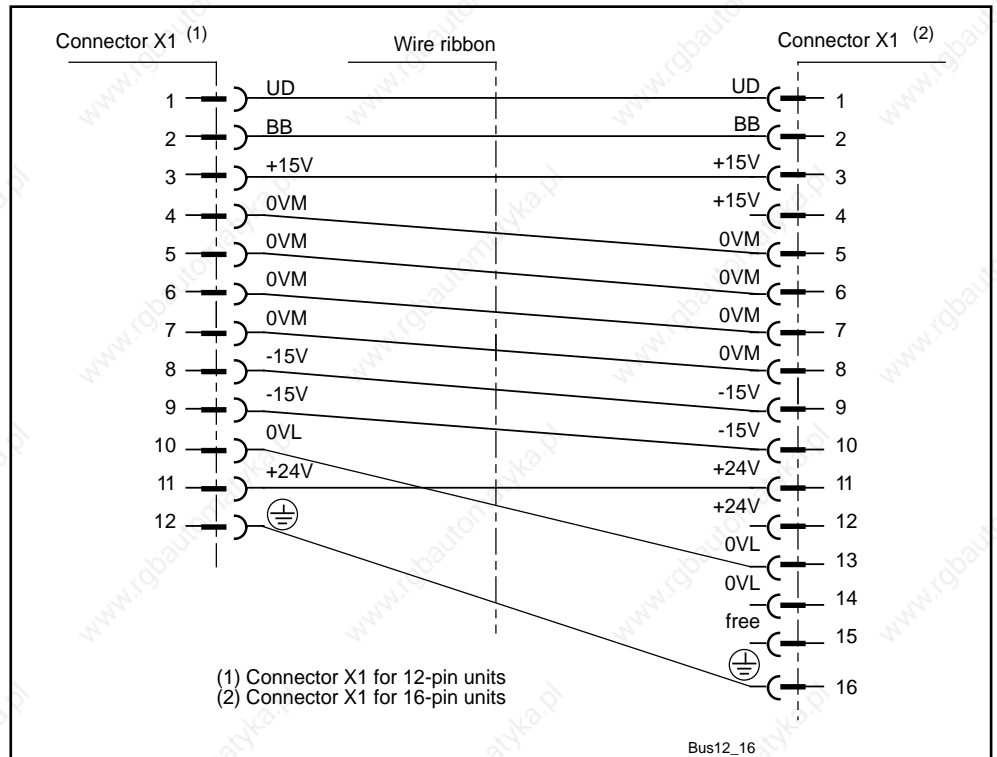

Figure 3.10: Wire-ribbon for transition from 12-pin to 16-pin connector

The wire-ribbon connection receives a termination connector used in verification of the connections. If the termination connector is not installed, the Bb1 contact of the power supply will not close.

The TVM 2.4 can also be installed in the middle of the drive system. In this case, it is sufficient to install the termination connector on one end of the wire-ribbon connection.

The termination connector is a component of the TVM electrical accessory kit.

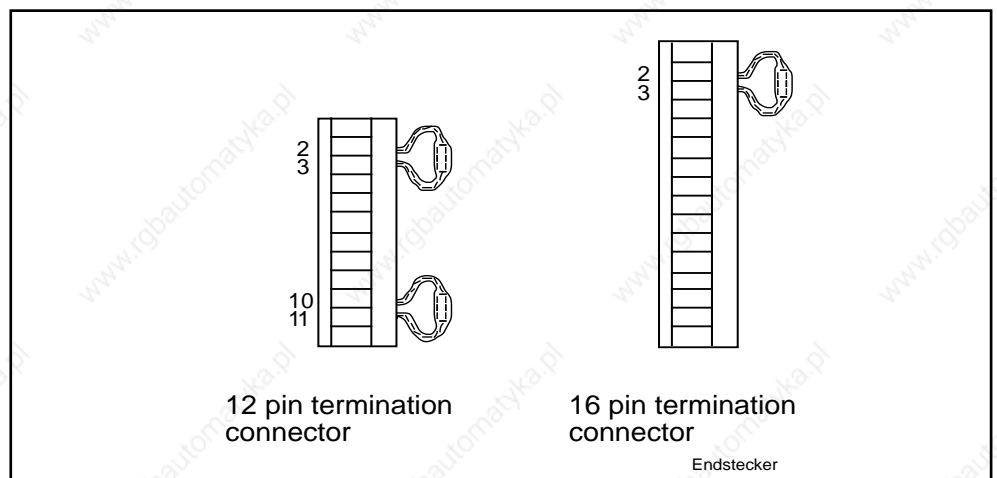

Figure 3.11: Termination connector for the wire-ribbon connection

3.11. Fault current protective device

No FI current limiting type circuit breakers are to be installed in the power lines to the TVM 2.4 (per VDE 0160, section 6.5).

3.12. Checking the control cabinet



There must be no voltages connected outside of those specified in the data sheet or interface description.

Before performing any high voltage test on the enclosure, remove all connections to the TVM 2.4.

3.13. Installing the TVM 2.4

The protection category of the TVM 2.4 is IP 10. It is designed for installation into a control cabinet.

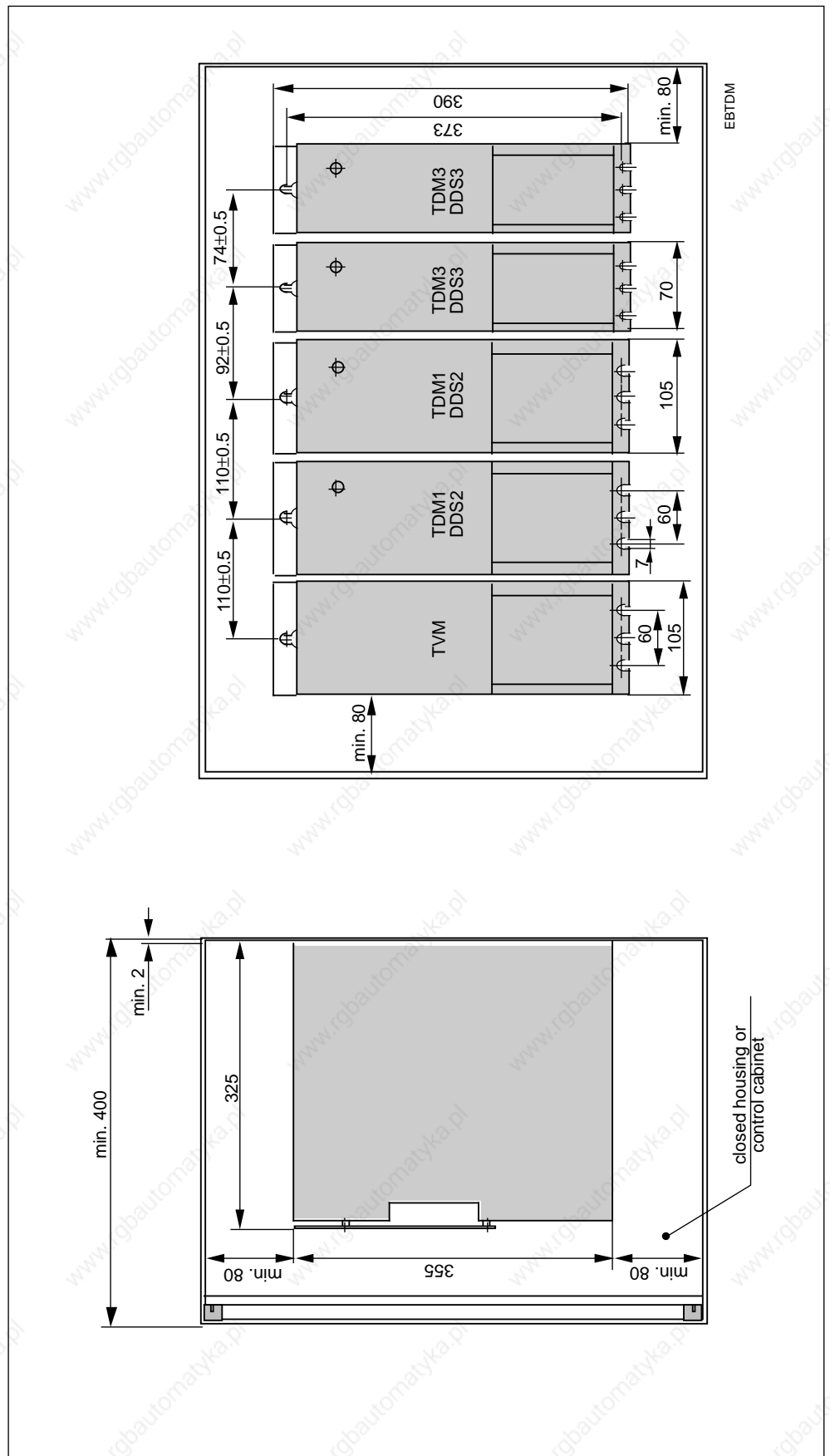

Figure 3.12: Installation dimensions and hole locations

3.14. Safety clearances

The bleeder resistors in the TVM 2.4 and TBM 1.2 modules heat up during operation. The path for heat away from the unit must not be obstructed.

Combustible materials such as wires and cable channels must be positioned at least 200 mm away on top and 40 mm to the side and front of the unit.

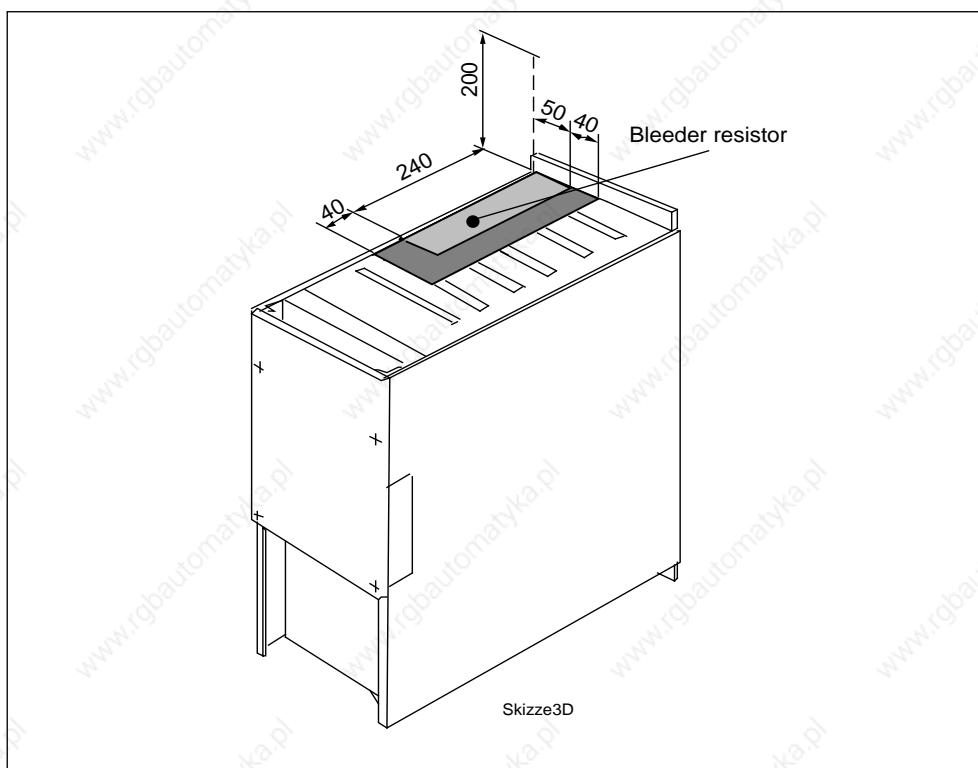

Figure 3.13: Spacing requirements for the TVM bleeder resistor

3.15. Heat loss within the control enclosure

In the TVM 2.4, basic losses due to the generation of signal voltages, power losses and bleeder losses occur.

Basic losses approximately 80 W

Power losses 7 W per kW continuous D.C. bus power.

Bleeder losses The bleeder losses are dependent upon the rotary drive energy, the potential energy of unbalanced masses and the number of machine cycles.

$$P_{RD} = \frac{W_{rotg} + W_{potg}}{t_z}$$

P_{RD} = continuous regenerated power or bleeder losses in kW

t_z = cycle time in seconds

W_{potg} = sum of potential energy in kW

W_{rotg} = sum of rotational energy in kW

For further details see selection and dimensioning guidelines!

3.16. Front view of the TVM 2.4

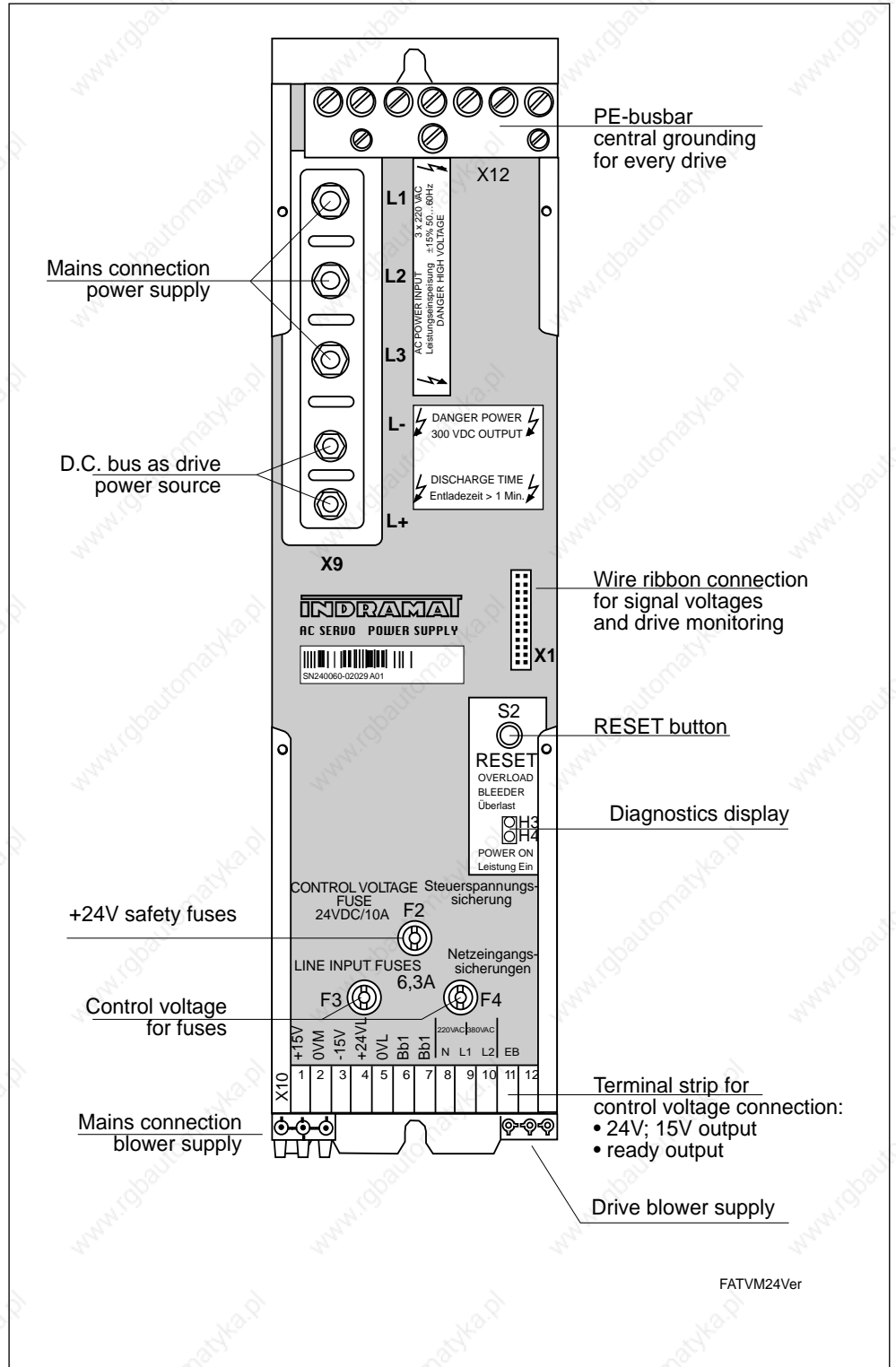

Figure 3.14: Front view of the TVM 2.4

4. Control circuits (control of input power)

The control signals for the mains contactor and the dynamic brake in the TVM 2.4 that are suggested by INDRAMAT illustrate the operating principle. Various control circuit possibilities are shown in this chapter.

The control scheme selected and its effect depends on the features and timing of the entire machine and is the responsibility of the machine builder.

4.1. Possible error reactions

Stopping because of drive faults

Bringing the drives to a standstill **with** or **without** dynamic braking.

With dynamic braking, synchronous motors (MAC or MDD) are always braked to a standstill whether or not the drive electronics are still operational. Asynchronous motors (2AD or 1MB) are not braked when the D.C. bus is short-circuited.

Without dynamic braking, intact drives can be braked at maximum torque. Drives with drive electronics malfunctions or interrupted feedback lines will coast down uncontrolled without electrical braking.

The dynamic brake can only be dispensed with if uncontrolled coasting will not damage the system. Motors with a mechanical holding brake can be used as an alternative.

4.2. Recommended error reactions



The best way to bring the drives to a standstill in a fault situation depends on the drive equipment used, and on the features of the machine. Thus, only the designer of the installation can make this decision. The following recommendations should, therefore, only be viewed as a support for the machine builder.

A few typical machine faults are listed below. The list of faults cannot, for the lack of space, be complete.

Bb1 open

TVM Bb1 contact open, limit switch open or following error signal from the NC

The Bb1 contact of the supply module opens if there is an error in the drive electronics or in the feedback line. Synchronous drives can, in this case, only be braked to a standstill with the use of the dynamic brake. For this reason, the dynamic brake should be applied if the Bb1 contact is open.

Limit switch open

The main purpose of the dynamic brake is the protection of the facility. The limit switches are only activated if there is an error in the control or in the drive. Thus, the dynamic brake should be applied when the limit switch is open. The distance overtravelled beyond the braking distance during a dynamic braking action should be measured.

Following error message from the NC controller

This message means that there is a fault in the drive. Therefore, when a following error signal occurs, have dynamic braking occur.



Dynamic braking can only be dispensed with, with respect to the above errors, if a coasting of the drives cannot damage the facility. Motors with mechanical holding brakes can be used as an alternative.

E-STOP, safety doors, light barriers or step-pad activated

Safety doors, light barriers, step pads or similar monitoring devices serve to protect personnel.

A: Facilities with modular asynchronous drives

Dynamic braking cannot be used in installations equipped with modular asynchronous drives (e.g., main spindle drives) once these monitoring devices are actuated because asynchronous drives cannot be braked. On a machine tool, for example, the danger from moving main drives should generally be estimated higher than the danger from feed drives.

Thus, if the referenced monitoring devices are actuated in installations of this type, then only the mains contactor and the drive enable signal should be switched off and dynamic braking should not be used.

B: Installations with modular synchronous drives, e.g., handling systems

Switching off the mains contactor and the drive enable achieves the shortest possible braking distances with intact drives. Only if the energy stored in the D.C. bus capacitors can cause a dangerous drive motion, must the dynamic braking be used with a fault.

Set-up operations with pendant enable key

Here as well, the shortest possible braking distances are achieved by switching the mains contactor and the drive enable off.



Summary

Dynamic brake contactors and resistors are not suited for jogging operations. If this is ignored, then there will be damage in the control cabinet.

Input signal ("error signal")	Dynamic braking			Drive enable and mains contactor OFF
	Individual components of the drive system			
	modular asynchronous and synchronous drives	only modular synchronous drives	only modular asynchronous drives	
Bb1 contact of the supply module is open	yes	yes	no	yes
Limit switch open	yes	yes		
Following error signal from the NC	yes	yes		
E-STOP button pressed	no	no For exceptions see above "B: facility with modular synchronous drives"		
Light barrier, step-pad or safety doors actuated	no	no For exceptions see above "B: facility with modular synchronous drives"		
Pendant enable button	no Danger of damage!			

4.3. DC bus short-circuiting switch

The DC bus short-circuit switch recommended by INDRAMAT is conceived to protect either machine or plant against damage in the event of a drive failure. This can be used to brake motors with permanent magnetic excitation even in the event of drive control failure. This function cannot, however, be the only safety device used to protect personnel.

Circuit design

This DC bus short-circuit contactor can switch the "short-circuit current" on but not off. The DC bus short-circuit contactor may not be re-applied, once released, until the DC bus has discharged. The following recommended circuits (section 4.4 to 4.6) will make interference-free operations possible. Programming the PLC appropriately does not guarantee the correct switching sequence. The varying contactor actuating times can possibly trigger the mains contactor before the DC bus short-circuit contactor is opened. This means that the mains contactor should additionally be locked by means of an auxiliary contact of the DC bus short-circuit contactor.



DANGER

The DC bus short-circuit resistor is not secured against accidental contact. There is the danger of high-voltages (greater than 50 V).

Electrical shock resulting from contact

==> use an appropriate cover, see that it is in place or properly mounted



CAUTION

Thermal damage caused by DC bus short-circuit contactor and resistor in the event of faults in the control or contactor is possible.

Damage or loss due to fire is possible inside the control cabinet.

==> use an appropriate cover, see that it is in place or properly mounted

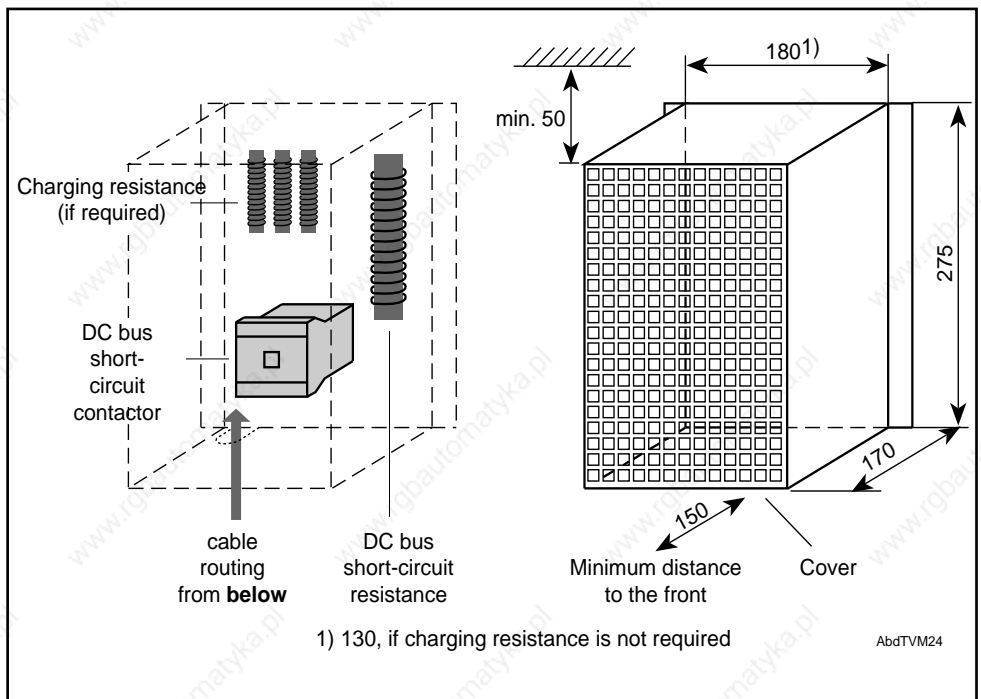

Fig. 4.1: Suitable covers and unit arrangements for the DC bus short-circuit

Switching frequency A maximum of six switching procedures is permitted per minute.

The number of possible switching sequences is reduced if the sum of the rotary drive energy and the energy stored in the additional capacitance is greater than 1500 Ws. Otherwise, the DC bus short-circuit resistor will be overloaded. The number of the permissible DC bus short-circuit actuations can be calculated as follows:

$$S = \frac{150W \cdot 60 \frac{s}{min}}{(W_{rot} + W_{ZK})}$$

- S = number of permissible actuations per minute (max. 6)
- W_{rot} = energy content of the drive given in Ws
- W_{ZK} = energy stored in the additional capacitance given in Ws

Service life The DC bus circuit contactor has a service lifespan of 20,000 actuations.

Maximum drive torque Once the DC bus is short circuited, the drive will be decelerated with the short-circuit torque. This torque may be higher than the maximum torque indicated in the selection list. Particularly, if the relationship maximum torque to short-term operating torque is less than 1.3, then there will probably be increased torque.



Increased torque with short-circuited DC bus is possible.

Damage to mechanical transmission parts, machine damage from dimensional shifting that has gone unnoticed.

==> mechanical transmission elements must be laid out in terms of the torque at with a short-circuited DC bus.

A list of the short-term torque for MDD motors can be requested. The following formula can be used to calculate maximum torque with a short-circuited DC bus.

$$M_{ZK} = \frac{Km^2 \cdot \omega}{\sqrt{(R_A + R_{ZK})^2 + (\omega p L_A)^2}}$$

$$M_{maxZK} = M_{ZK} + M_H$$

- M_{maxZK} = max . drive torque with short-circuited DC bus
- M_{ZK} = short-circuit torque in Nm
- M_H = decel torque of the holding brake in Nm
- Km = current torque or voltage constant in Vs/rad
- ω = angle speed in rad/s
- R_A = winding resistance of the motor in Ω
- R_{ZK} = DC bus short-circuit resistance in Ω (2.2 Ω)
- p = number of pole pairs; for MAC and MDD the following applies:
size \leq 41; $p = 2$
size \geq 63; $p = 3$
- L_A = winding inductance of the motor in H

4.4. Control circuit without soft-start resistor with dynamic braking

Applications A power transformer capacity of up to and including 10 kVA, without added capacitors.

A power transformer capacity of up to and including 2.5 kVA, with added capacitors.

Features Power is switched on directly without soft-start resistors. The inrush current is limited by the power transformer.

Dynamic braking will always stop synchronous motors regardless of whether the drive is still functioning or not. Dynamic braking **is only activated for drive faults**.

For emergency stop or if a monitor of the TVM 2.4 is tripped, drives are stopped **electrically under drive regulation at maximum torque**.

Mode of functioning When the ON-button is pressed, then both mains contactor and dynamic braking contactor pick up immediately and are latched.

The mains contactor drops out immediately when the emergency-stop button is pressed. The drive enable is switched off by an auxiliary contact of the mains contactor. This leads to the velocity command being switched to zero on all drives. There is a controlled braking of all drives.

A drive fault message from the TVM 2.4 (Bb1 contact), a fault signal from the NC controller (servo error), or the tripping of an axis travel limit switch cause the mains contactor to switch off and dynamic braking to be activated (see section 3.6, Installation of dynamic brake).

Control circuit: • with dynamic brake
• without soft-start resistor

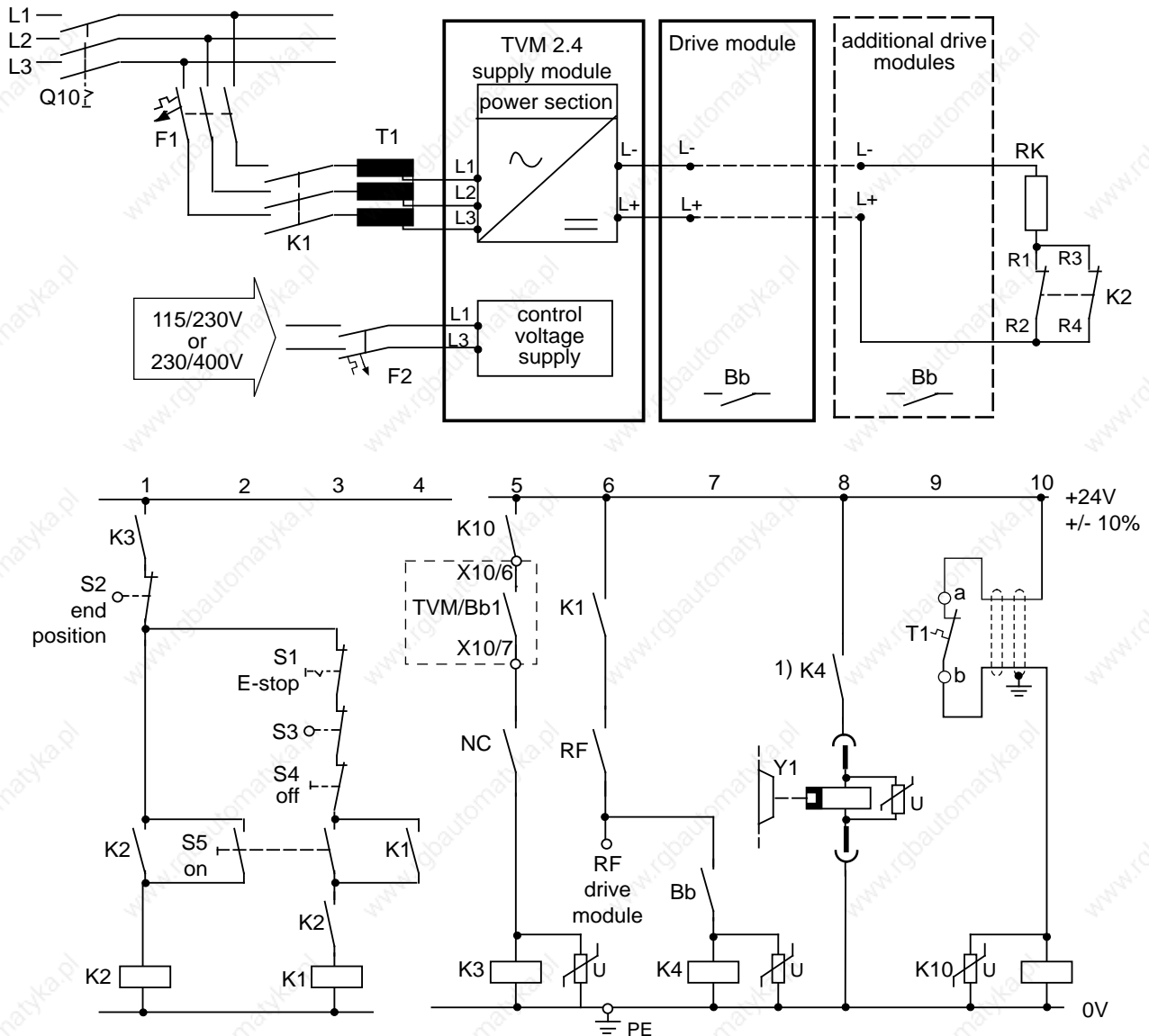

- 1) Only for feed drive holding brakes which are not controlled by the drive module.
- | | |
|--|--|
| Bb1 = supply module ready (drive system) | Q10 = main disconnect |
| Bb = drive ready contact of drive module | RF = drive enable signal from controller |
| F1 = fuse for input power | RK = dynamic brake resistor |
| F2 = electronics and blower fuses | S1 = E-STOP |
| K1 = main contactor | S2 = axis limit switch |
| K2 = dynamic brake contactor | S3 = safety doors |
| K3 = decouple Bb1 | S4 = power off |
| K4 = holding brake control | S5 = power on, cancel dynamic braking |
| K10 = decouple thermal contact for power transformer | T1 = power transformer |
| NC = error signal from the control | Y1 = Take delay time of electrically released holding brake of feed axes into account! Do not apply a velocity command until 100 ms after RF-ON. |
| - open for fault drive (servo error) | |
| - closed for E-STOP | |

NOTE! After K2 drops out, the contact must not be switched on for 0.5 seconds. Opening and closing of K2 due to S2 or K3 being activated intermittently must absolutely be prevented, otherwise K2 may be damaged. After it is switched off, contactor K2 must only be re-energized by a defined command, for example, S5.

SSTVM2.4/1

Figure 4.2: Control circuits without soft-start resistor, with dynamic braking

4.5. Control circuits with soft-start resistors, for applications with TDM drive modules

Applications With the use of drive modules of the TDM, KDS and TDA series and under the following conditions:

- a power transformer capacity greater than 10 kVA, without added capacitors,
- a power transformer capacity greater than 2.5 kVA, with added capacitors, or,
- direct connection to a 3x AC 220 V mains.

Features The soft-start resistors limit the inrush current.

Synchronous motors are always braked to a standstill by dynamic braking regardless of whether the drive electronics are still functioning or not. Dynamic braking **is only applied in the presence of a drive fault.**

There is a **controlled braking of the drives under drive regulation** at maximum torque if either an E-STOP should become necessary or if the TVM's monitors are triggered.

Operation When the ON-button is pressed, then both mains contactor and dynamic brake contactor immediately pull in. Once the DC bus is charged and the Bb contact of the drive module is closed, then the soft-start is by-passed.

The mains contactor drops out immediately when the E-STOP button is pressed. An auxiliary contact on the mains contactor switches the drive enable signal off. Internal to the drive, this leads to the velocity command being switched to zero on all drives. There is a controlled braking of all drives.

A drive fault signal from the TVM 2.4 (Bb1 contact), a fault signal from the NC controller (servo error), or the tripping of an axis travel limit switch results in the main contactor being switched off and activation of dynamic braking (see section 3.6, Installation of dynamic brake).

4. Power circuits

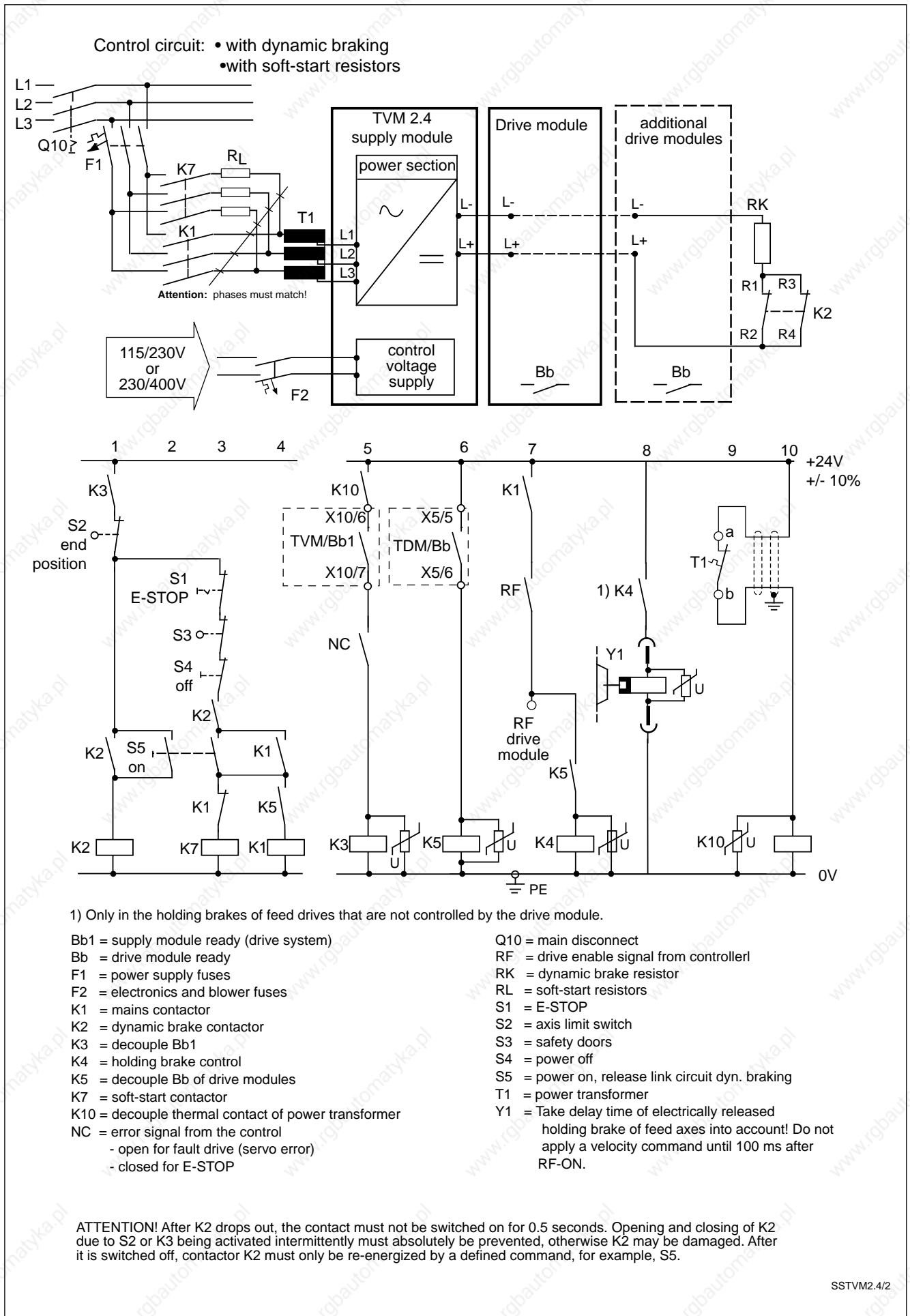

Figure 4.3: Control circuits with soft-start resistor with the use of a TDM drive module

4.6 Control circuit with soft-start resistor, for applications with DDS drive controllers

- Applications* For use with DDS series drives and under the following conditions:
- power transformer greater than 10 kVA, without added capacitors,
 - power transformer greater than 2.5 kVA, with added capacitors, or,
 - direct connection to a 3x AC 220 V mains.

The soft-start resistors limit the inrush current.

- Features* Dynamic braking will always stop synchronous motors regardless of whether the drive is still functioning or not. Dynamic braking **is only activated for drive faults**.

For emergency stop or if a monitor of the TVM 2.4 is tripped, drives are stopped **electrically under drive regulation** at maximum torque.

- Operation* When the ON-button is pressed, then both the soft-start contactor and D.C. bus dynamic brake contactor pull in. After the soft-start charging time has passed, the main contactor pulls in by means of a time relay and by-passes the soft-start contactor.

The mains contactor drops out immediately once the E-STOP button is pressed. An auxiliary contact of the mains contactor switches the drive enable signal off. Internal to the drive, this leads to the velocity command being switched to zero on all drives. All drives are braked under drive control.

A drive fault signal by means of the TVM Bb1 contact, a NC fault signal (servo fault), or the tripping of an axis travel limit switch results in the main contactor being switched off and actiation of dynamic braking (see section 3.6).

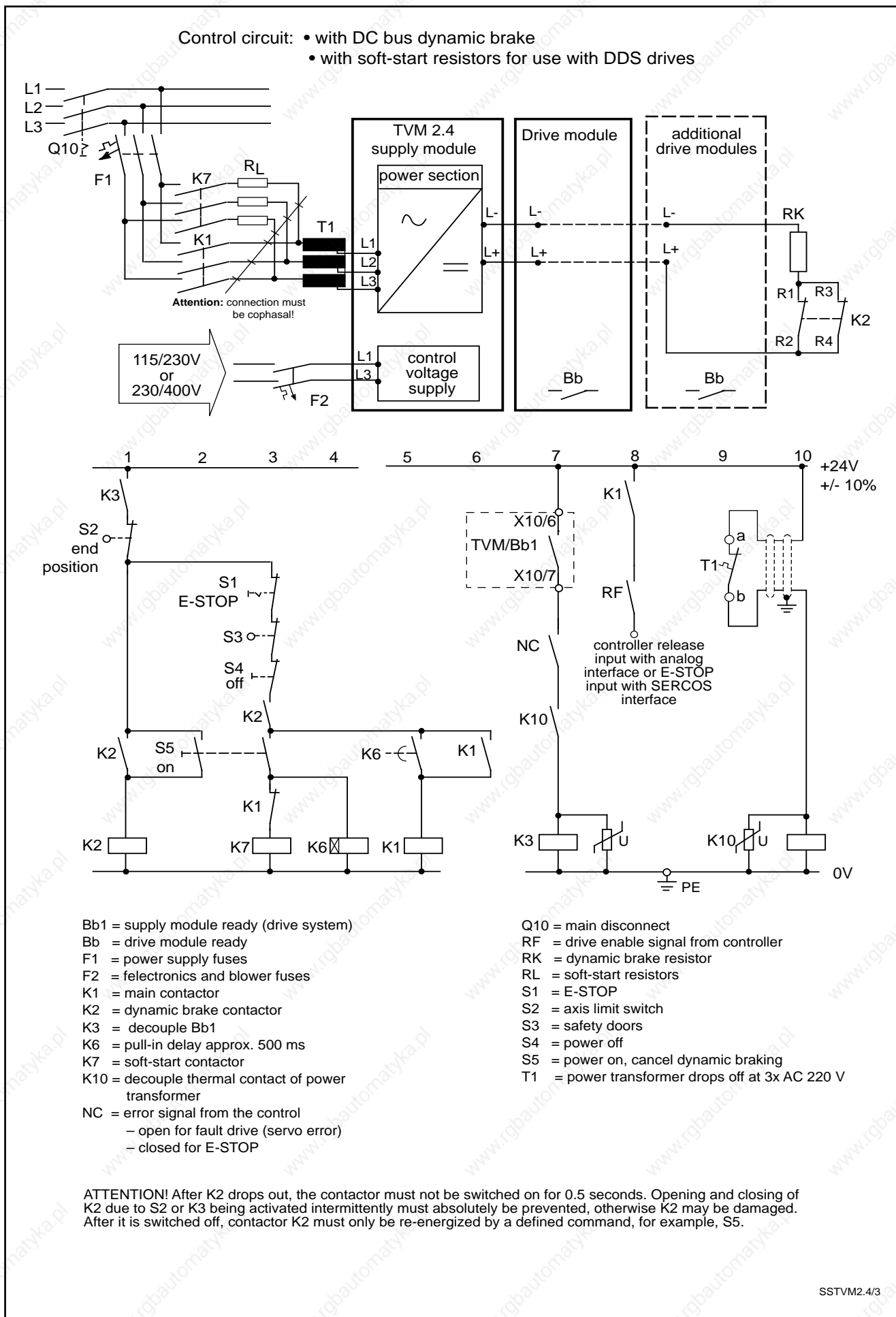

Figure 4.4: Control circuits with soft-start resistors, for use with DDS drive controllers

5. Interface descriptions

5.1. Signal voltages

The signal voltages can be obtained from terminal strip X10. These terminals are intended for measuring and test purposes. If these voltages are used outside of the TVM, then ensure that no interference voltages are coupled in (use short, shielded cables; relay coils should have no voltage suppression).

To ensure proper operation of the drives, do not exceed the load capacity of the signal voltage outputs.

Terminal	Signal voltage	Maximum load capacity
X 10/1	+ 15 V _M	100 mA
X 10/2	0 V _M	—
X 10/3	- 15 V _M	100 mA
X 10/4	+ 24 V _L	2 A
X 10/5	0 V _L	—

5.2. Ready signal

Output Bb1 Potential-free contact - terminal X 10/6 - X 10/7

Maximum load: DC 24V/1A

(Do not connect relay coils with high inrush current directly to this contact.)

Operation	Relay voltage-free	Fault	Ready to operate
Output	open	open	closed

The Bb1 contact of the TVM 2.4 has a high priority significance. The emergency stop chain of the drive system is tied into the Bb1 contact. Only when it is closed may the three-phase AC power supply be applied.

The Bb1 contact closes when power for the electronics supply is applied to X10 /8/9/10, and there is no fault.

The Bb1 contact opens for the following faults:

- tachometer fault
- overtemperature in one of the drives
- overcurrent fault in one of the drives
- a fault in the +/-15VM / +24VL signal voltages
- an open in the wire-ribbon connection or missing termination connector
- bleeder overloaded

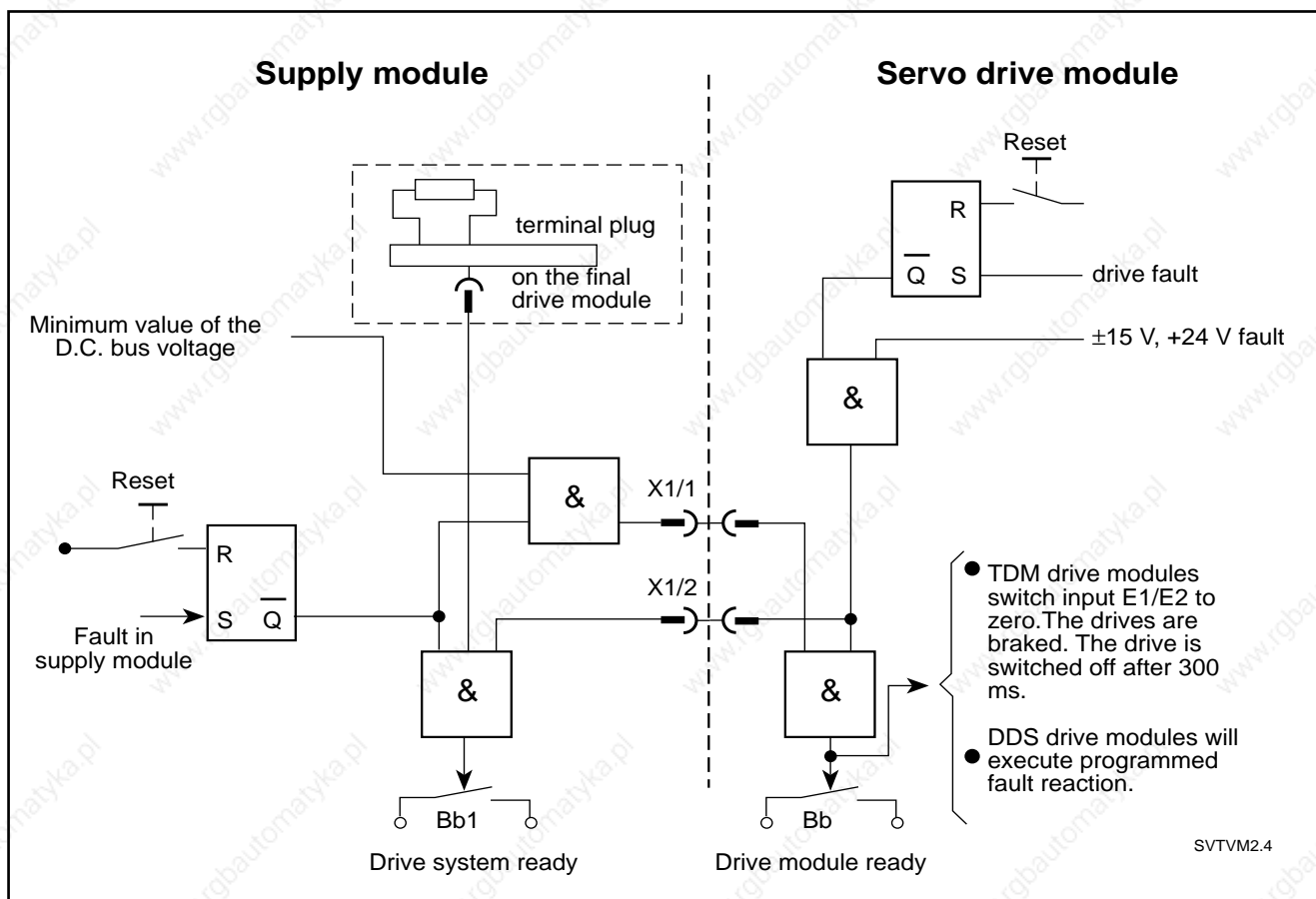

Figure 5.1: Drive monitoring and diagnostics systems

5.3. Additional bleeder control

Output EB Terminal X10 /11

An output voltage of up to 425 V; output current of 500 mA

Additional bleeder module TBM 1.2 can be controlled over output EB.

The cross section of the cable between output EB and input EB of the TVM 2.4 may not be less than 1,5 mm² (maximum connecting cross section equals 2.5 mm²).



The output voltage can equal up to 425 V !

6. Trouble-shooting guides

Because of the resulting production down-time, lengthy fault-finding and repairs to drive components on the machine are unacceptable.

Thanks to their construction, INDRAMAT A.C. drives enable individual functional units to be easily and completely replaced without the need for tuning.

This means that, in the event of a fault, servicing is limited to fault-location either in the motor, the power supply module or the drive, or simply exchanging the faulty component.

6.1. Troubleshooting

Because of the interaction between NC controller, supply and drive modules, motor, mechanical system and position measurement, poor performance of axis movements can be caused either by a fault in the above devices or incorrect interfacing of individual components. The TVM 2.4 is fitted with a comprehensive diagnostic system for rapid fault location.

6.2. Safety guidelines

There is increased risk of an accident in the presence of a fault. Personnel, the machinery and the drives are at risk.



Troubleshooting and equipment repair must only be performed by trained personnel.

Danger due to drive axis motion:
When troubleshooting, undesired axis motion is possible.



There should be no personnel within the danger zone. Safety measures such as safety screens, covers and light barriers must be present.

There must be free and ready access to the E-STOP button.

The following applies when working within the danger zone:



The power to the installation must be switched off and lock-out the system so that it cannot be switched back on when working within the danger zone.

Wait until the DC bus circuit has completely discharged (approximately five minutes).

Verify voltage by measuring at X9 /L+/L-.

*Danger due to voltage
conductive parts*

Dangerous voltages can be present at the following connections:

- at all supply module connections and associated transformers, capacitors and additional bleeders. In particular, at the power connections (terminal X9), control voltage input X10, as well as the blower supply connections X13 and X14.
- At the drive modules, motors and the plug-in connections of the motor connections.

Before working on electrical devices:



Use the main disconnect to cut power to the entire installation and make sure it cannot be switched back on.

Wait for the DC bus to discharge (approximately five minutes). Verify voltage by measuring it at X9 /L+/L.

Do not run motor. The motor connections are energized during any movements of the motor.

Before switching on:



Only turn on the power after installing the touch-cover shipped with each unit.

*Notes on protecting
the machine*

To avoid damage to the machine, note:



The initial start-up should only be performed by trained personnel. Make sure that the E-STOP and the axis limit switches operate properly.

*Notes on protecting
the unit*

Before switching on:



Make sure that the circuitry agrees with the TVM interconnect diagram and the schematic for the machine.

Electrostatic loads

Electrostatic loads are hazardous to electronic components.

Ground all objects prior to contact with the units.

6.3. Diagnostics displays

Attention: The signals are only valid if the "+24V, ±15V"- LED display is lit.

- (1) Signal and unit disabling are latched.
Reset by pressing the reset button or by cycling power to the electronic power supply.

Light-emitting diodes		Off	Constant light
H3	Überlast OVERLOAD BLEEDER red	Continuous bleeder operation is in the permissible range OK	Shutdown due to high bleeder power, mains voltage too high, or defective supply module.
H4	Leistung Ein POWER ON green	Power not switched on or power outage.	High voltage power OK

DiagTVM2.4

Figure 6.1: Diagnostic displays of the TVM 2.4

6.4. List of faults and their remedies

Signal

BLEEDER OVERLOAD Shutdown due to high bleeder power

Possible causes:

- The continuous regenerated power is greater than the permissible continuous bleeder power of the TVM 2.4.
- Energy of the drives is too high.
- Fault in the TVM 2.4

Remedies:

- Check the start-stop frequency of the drive.
- Check the drive energy.

POWER ON No DC bus voltage

Possible causes:

- Mains fuse have blown out.
- No mains voltage applied because the mains contactor is not pulled in.
- Mains voltage too low.
- Missing phase.

Remedies:

- Check the mains fuses.
- Check control circuit for mains contactor.
- Check transformer connections; measure mains voltage.

*Fault***Bb1 contact "open" Drive system not ready for three-phase power.**

Possible causes:

- Fault in one of the drives.
- Termination connector missing.

Remedies:

- Check diagnostics display on the drive.
- Check installation of the wire ribbon cable.
- Check for the termination connector.

+24 V ±15 V "missing" + 24 V ± 15 V control voltages have a fault.

Possible causes:

- Control voltage input to X10 is wrong or not connected.
- Maximum signal voltage load exceeded.
- The fuses F2, F3 or F4 on the TVM 2.4 have been burned out.

Remedies:

- Check the fuses in the enclosure.
- Disconnect the wire-ribbon cable to the drives and recheck the voltages.
- Disconnect the signal voltages tapped off from the TVM for use outside the TVM and drive modules and check these for short-circuits.
- Check fuses F2, F3 and F4.

6.5. Fuses

The signal voltage fuses are easily accessible and located on the front of the TVM 2.4.

Designation of fuse	Type of fuse
F 2	T 10 A / 250 V
F 3 and F 4	with TVM 2.4-050-300-W1/115/220 T 10 A / 250 V with TVM 2.4-050-300-W1/220/380 M 6.3 A / 250 V

7. Dimensional data

7.1. TVM 2.4 supply module - dimensional data

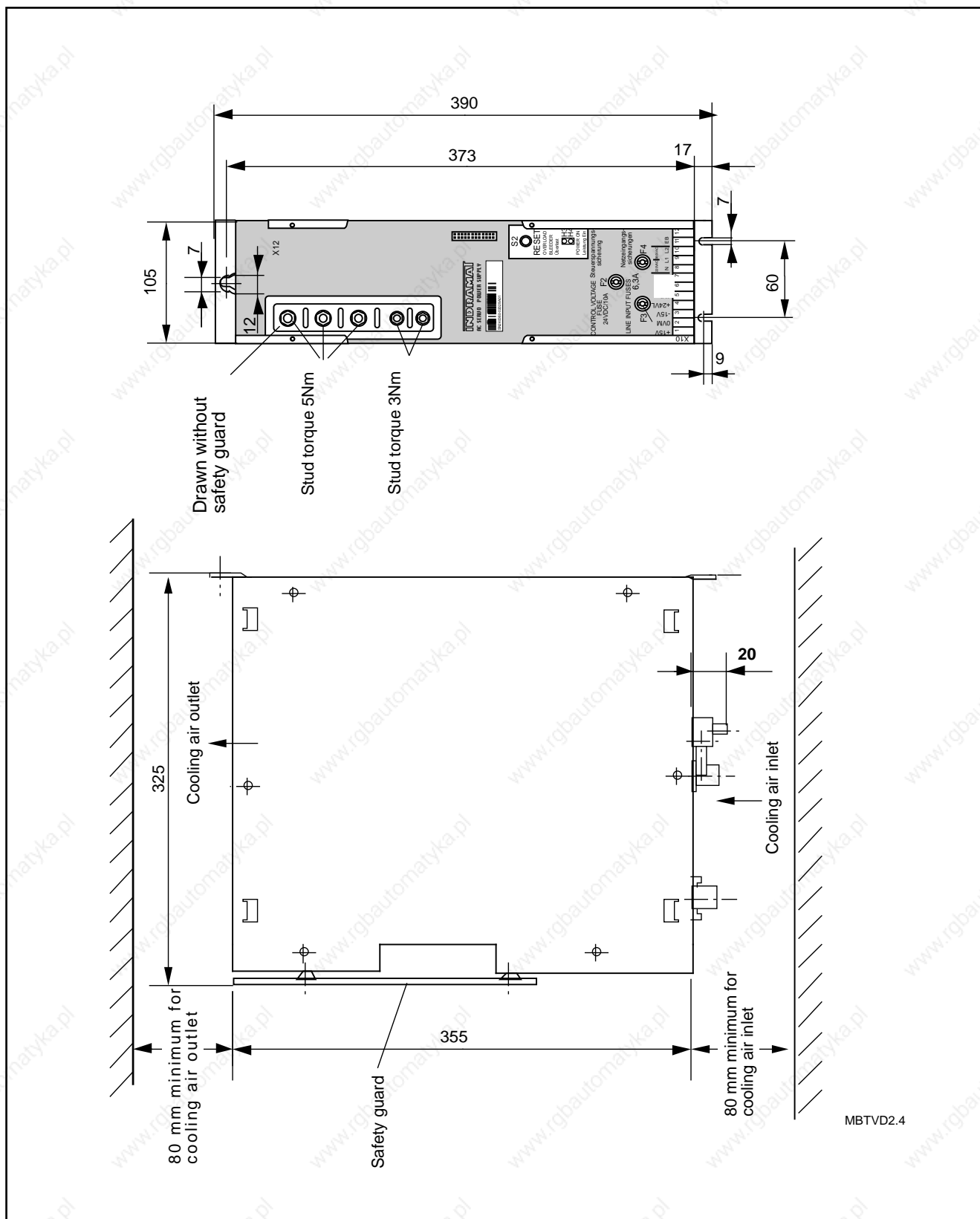

Figure 7.1: TVM 2.4 - dimensional data

7.2. Dimensions for DST autotransformers

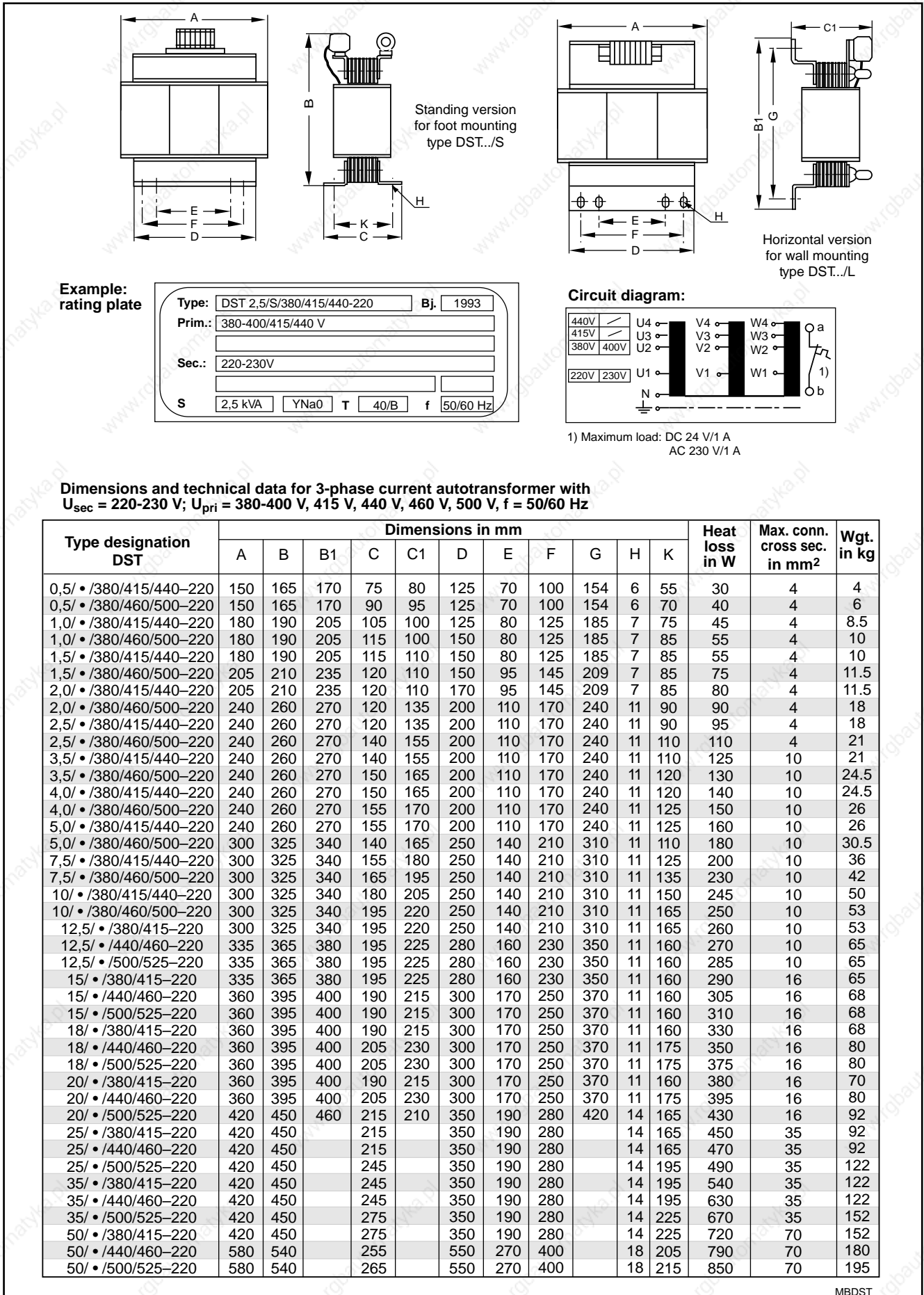

Figure 7.2: 3-phase current DST autotransformer dimensional data

7.3. Dimensions for DLT isolation transformers

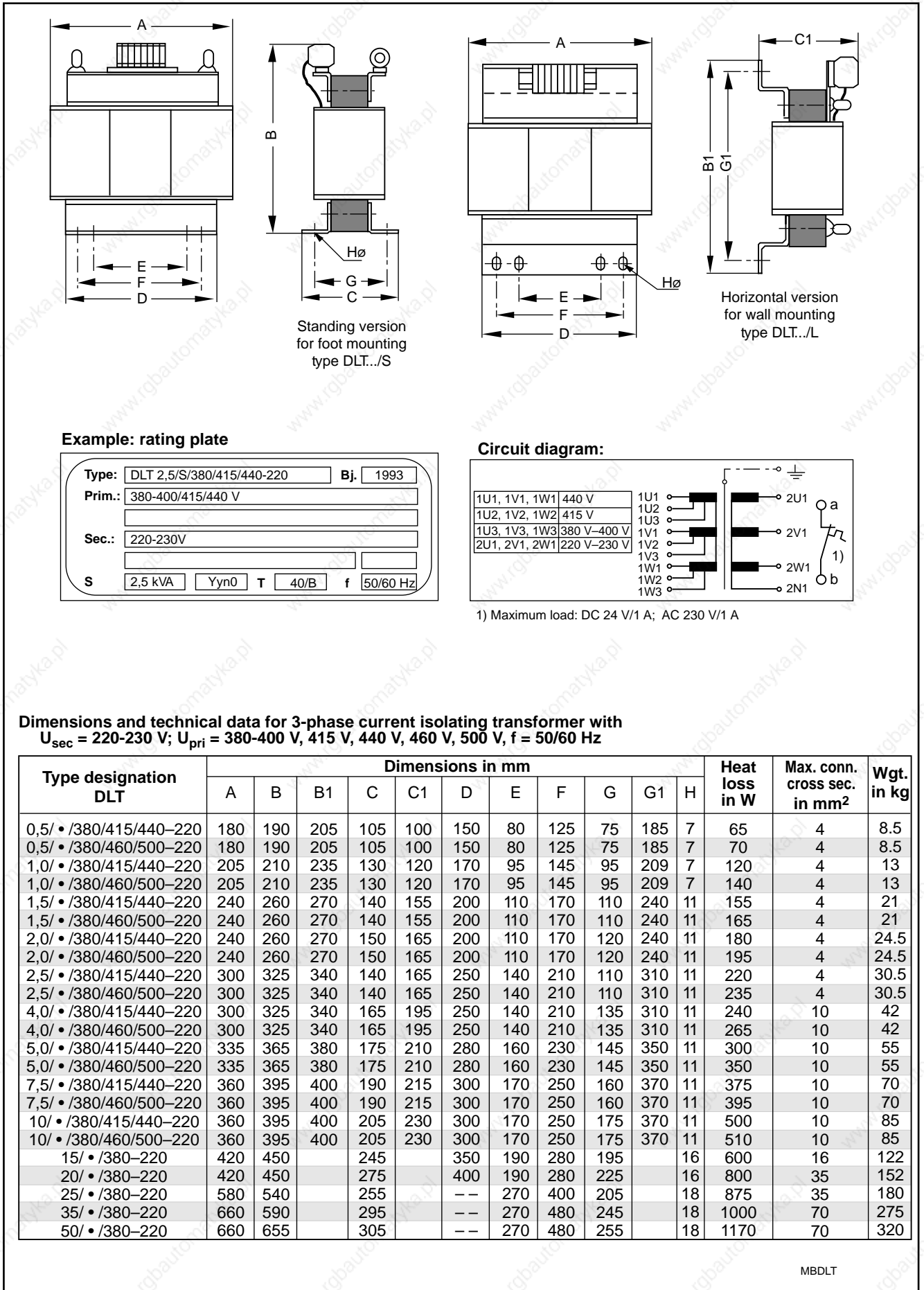

Figure 7.3: 3-phase current DLT isolation transformer dimensional data

7.4. Dimensions additional capacitor CZ 1.02

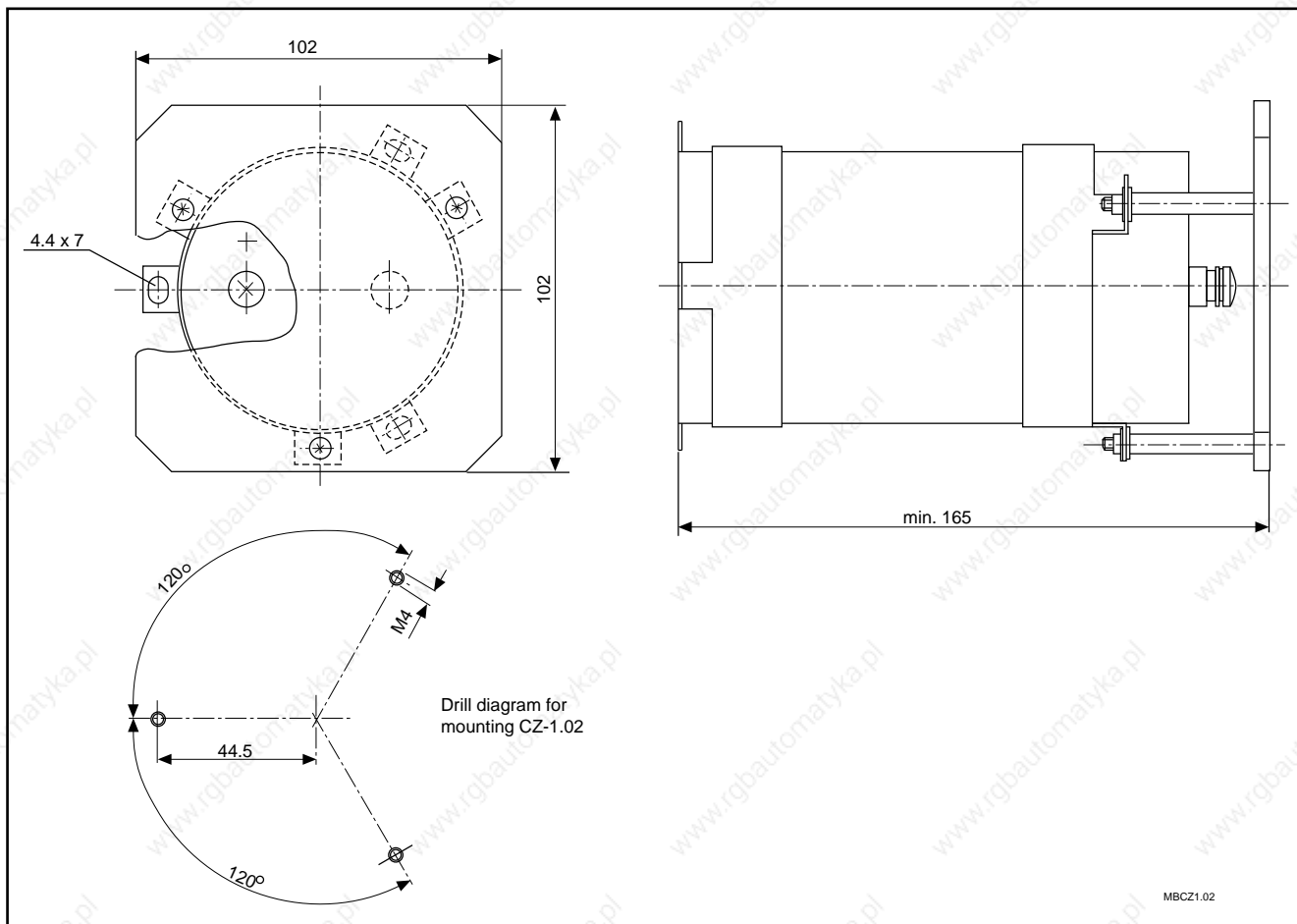

Figure 7.4: CZ 1.02 additional capacitor - dimensional data

7.5. Dimensions additional capacitor TCM 1.1

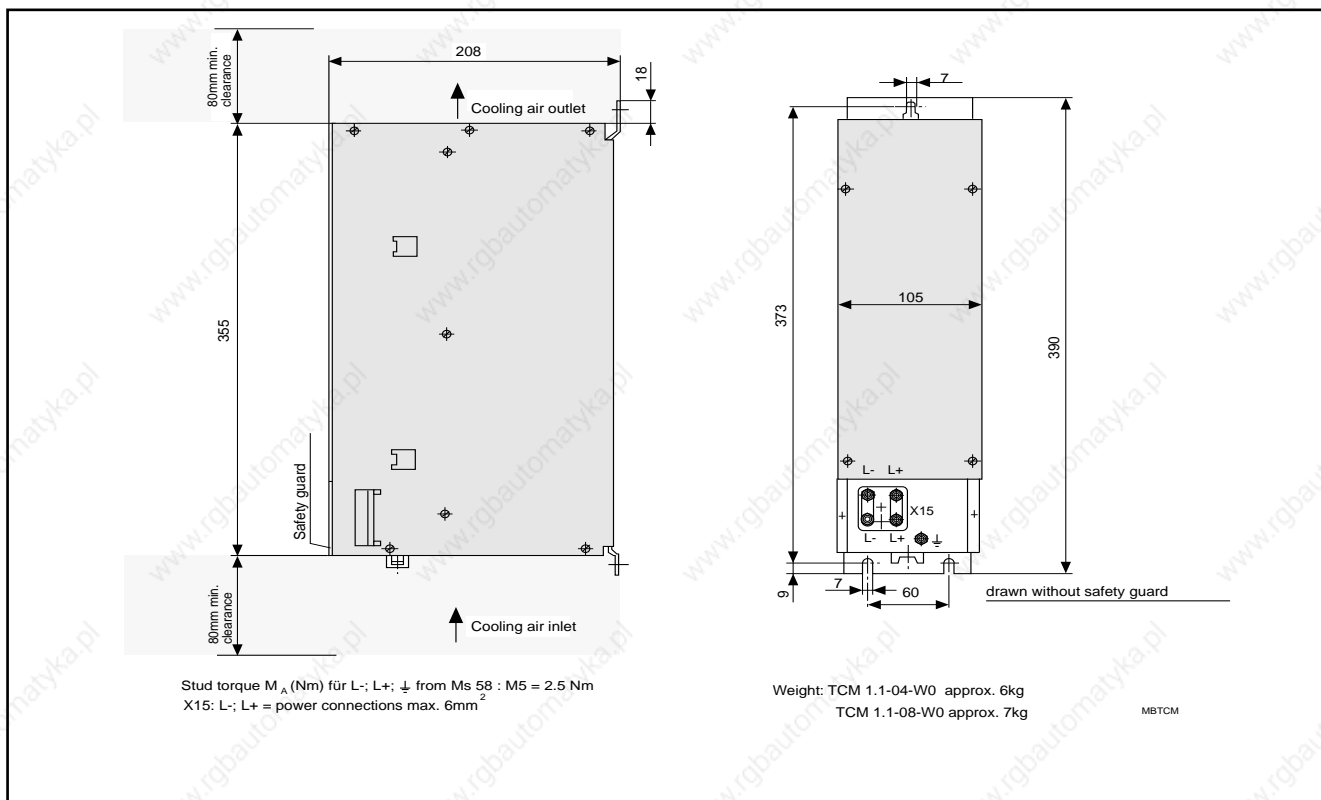

Figure 7.5: TCM 1.1 additional capacitance module - dimensional data

7.6. Dimensions for bleeder module TBM 1.2

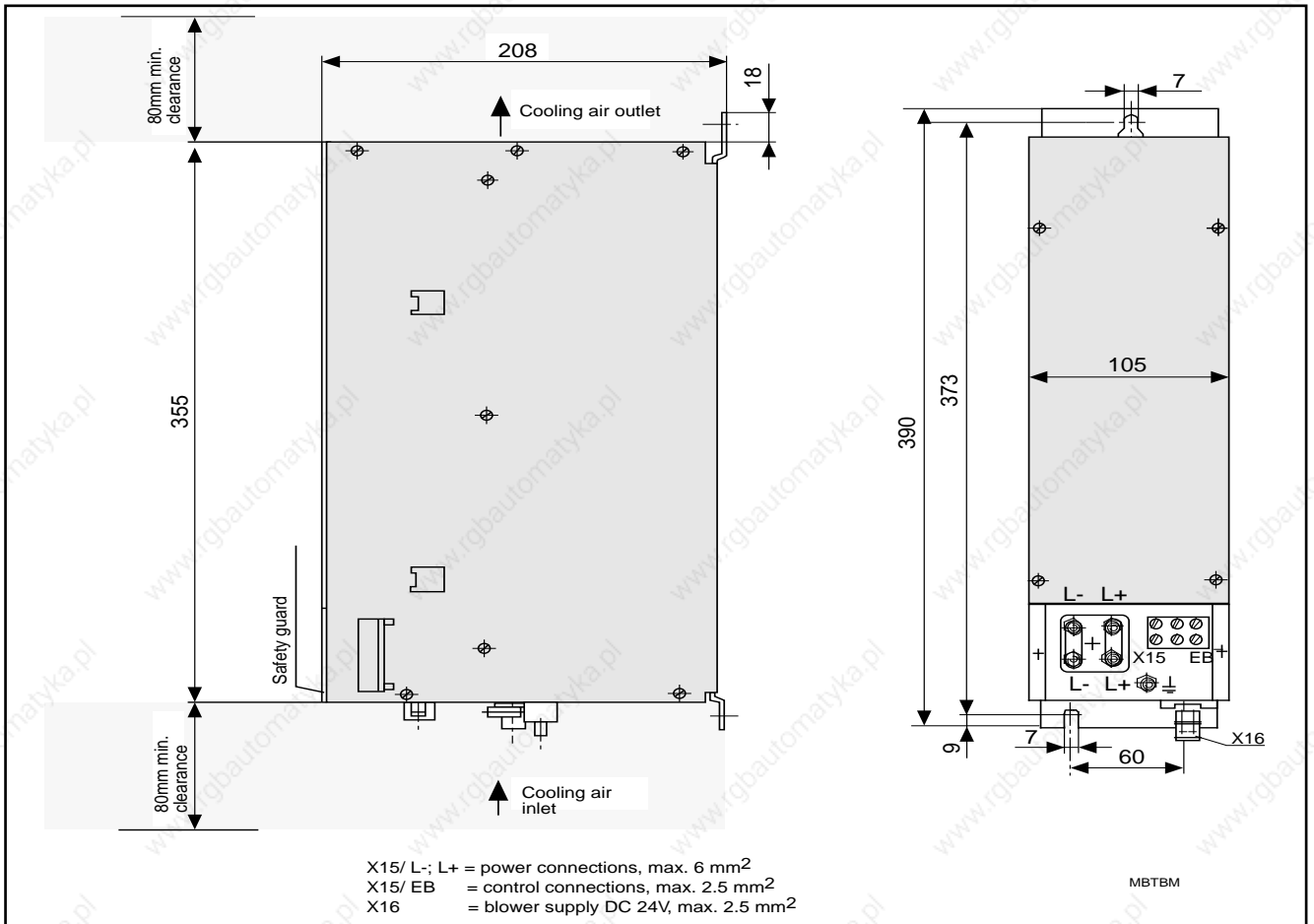

Figure 7.6: TBM 1.2 additional bleeder module - dimensional data

7.7. Dynamic brake contactor

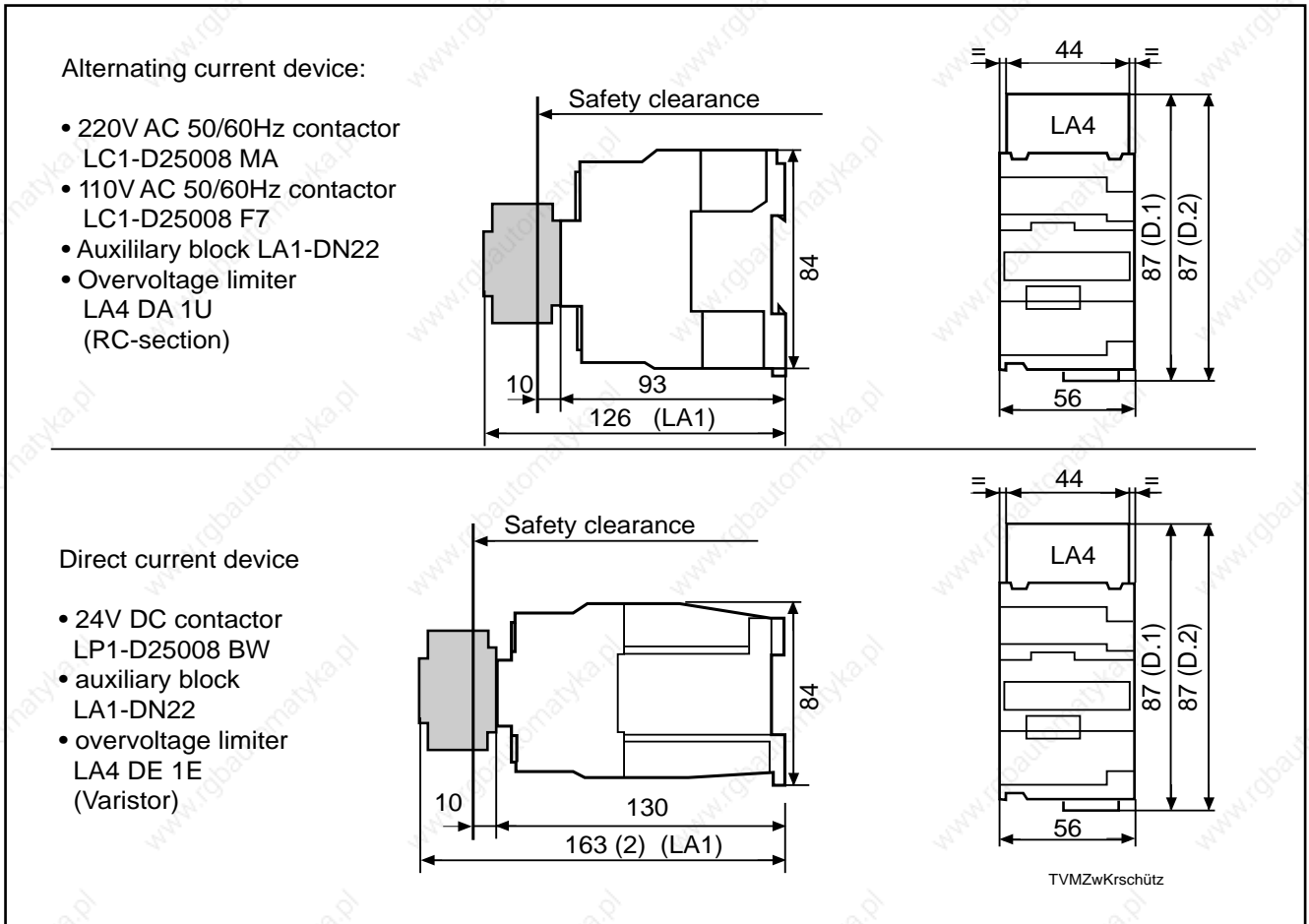

Figure 7.7: Dynamic brake contactor

7.8. Dynamic brake resistor

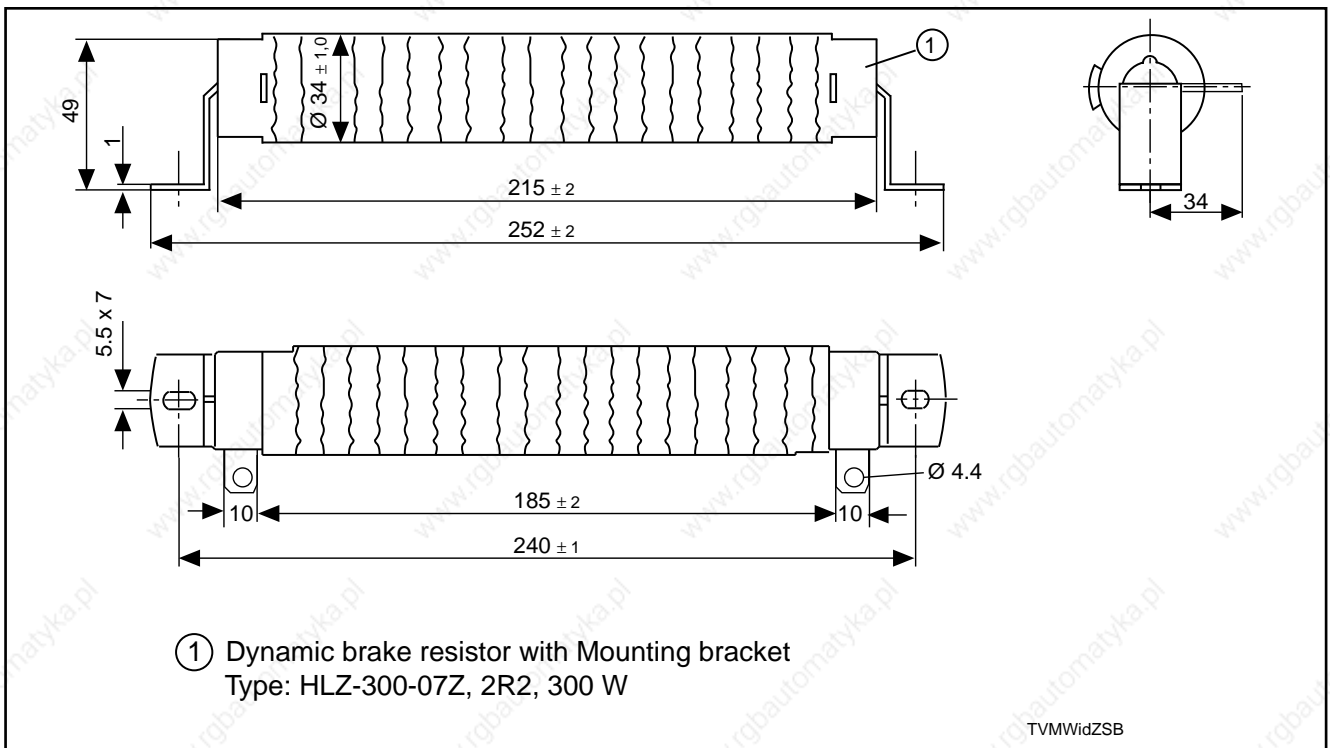

Figure 7.8: Dimensional data for dynamic brake resistor

7.9. Soft-start resistor

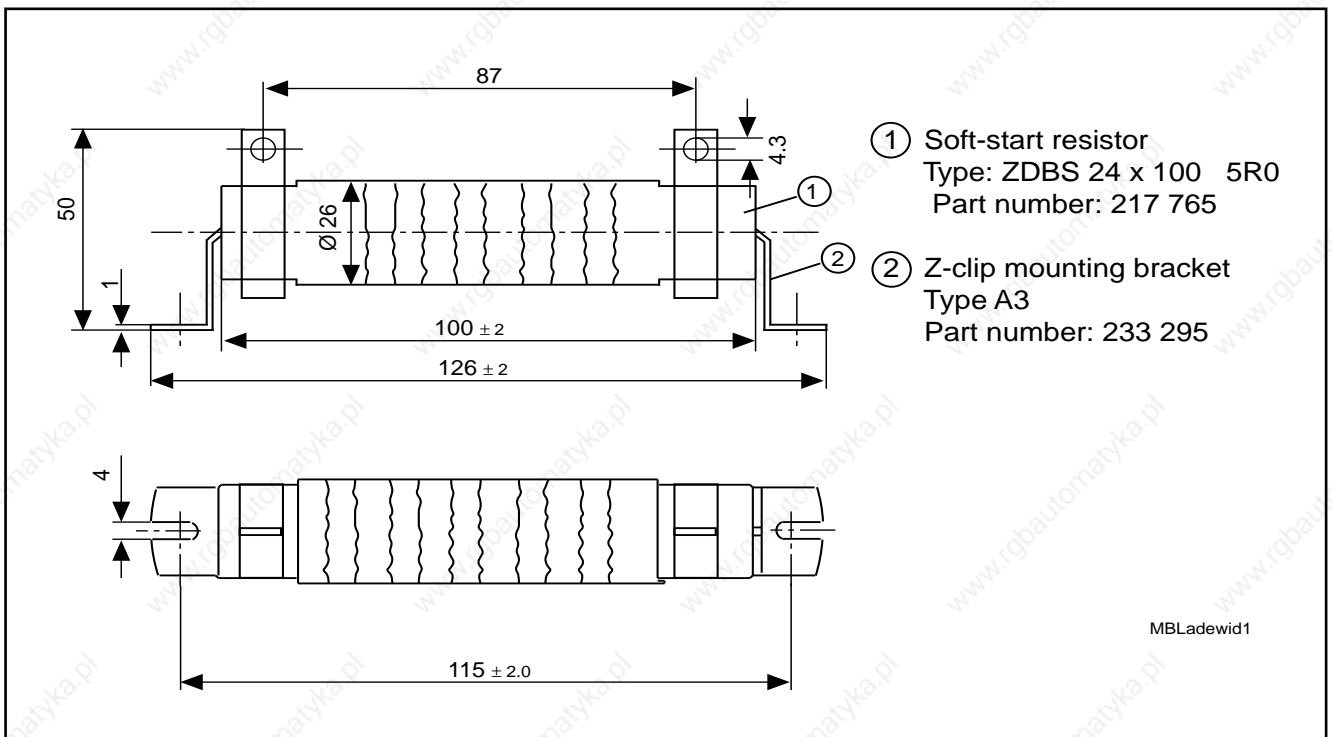

Figure 7.9: Soft-start resistor

7.10. Single-phase transformer

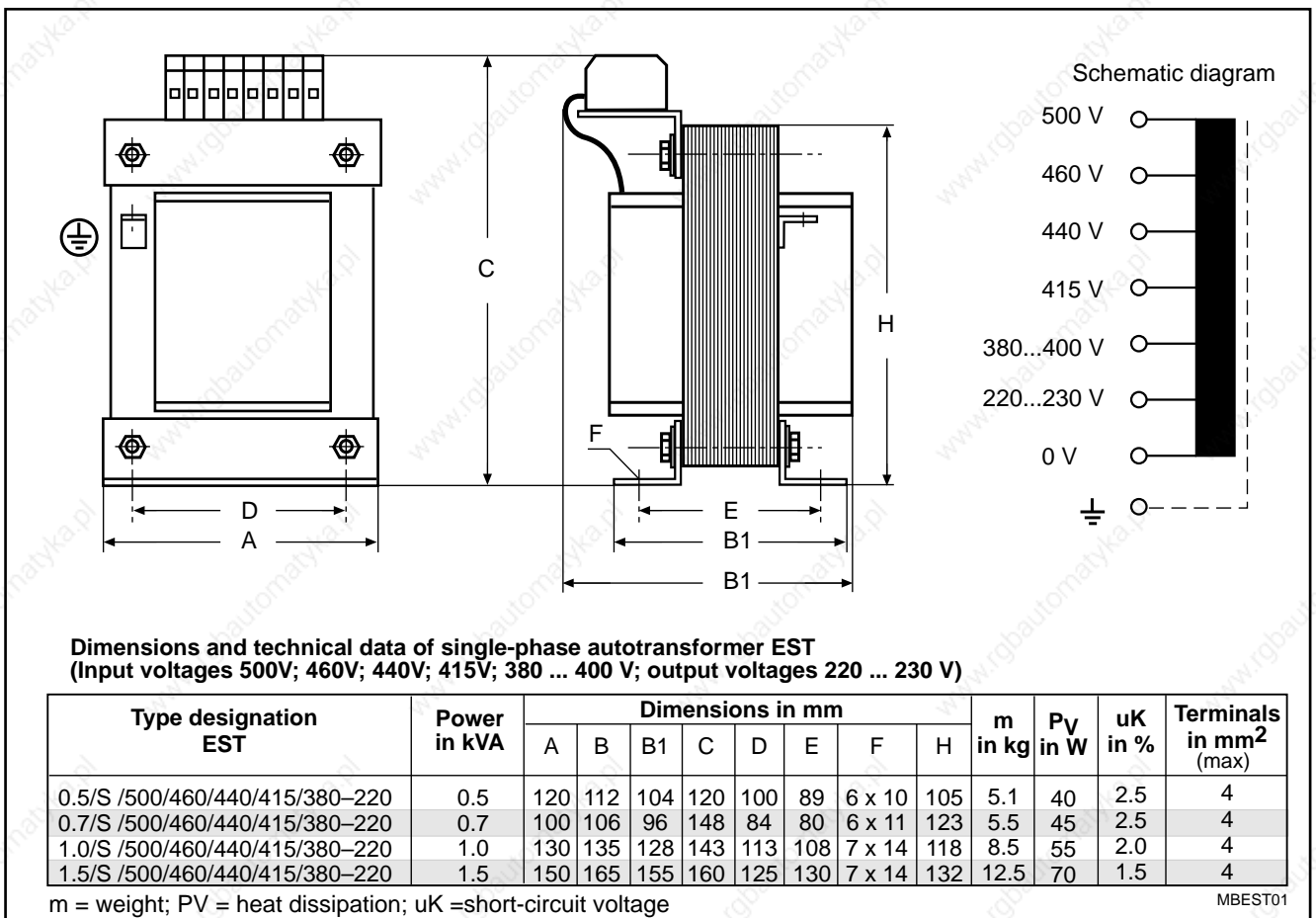

Figure 7.10: Single-phase transformer

8. Order information

8.1. TVM 2.4 type codes

Example: TVM 2 4 - 0 5 0 - 2 2 0 / 3 0 0 - W 1 / 1 1 5 / 2 2 0	
Designation	TVM = TVM
Series	2 = 2
Configuration	4 = 4
Type current	50 A = 050
Three-phase input voltage	AC 220 V, 50...60 Hz = 220
Nominal DC bus voltage	DC 300 V = 300
Cooling method	built-in blower = W1
Single phase input voltage for control electronics	AC 115 or 220 V, 50...60 Hz = 115/220 AC 230 or 400 V, 50...60 Hz = 220/380

Figure 8.1: Type codes for a TVM 2.4

8.2. Available configurations of supply module TVM 2.4 and accessories

Available configurations:

- | | |
|------------------------------------|--|
| 1. Supply module | TVM 2.4-050-220/300-W1/115/220
TVM 2.4-050-220/300-W1/220/380 |
| 1.1 Electrical accessories | E1-TVM
E2-TVM
E3-TVM |
| 2. Add. bleeder module | TBM 1.2-40-W1-024 |
| 3. Add. capacitance | |
| 3.1 Add. capacitor | CZ 1.02 (2mF capacitor) |
| 3.2 Add. capacitor mod. | TCM 1.1-04-W0 (4 mF)
TCM 1.1-08-W0 (8 mF) |
| 4. Dynamic braking | |
| 4.1 Dynamic brake contactor | |
| Coil voltage | DC 24 V LP1 D25 008BW |
| Coil voltage | AC 220 V 50/60 Hz LC1 D25 008M7 |
| Coil voltage | AC 110 V 50/60 Hz LC1 D25 008F7 |
| Auxiliary block | LA1 DN 22 |
| 4.2 Dynamic brake resistor | HLZ-300-07 Z
(includes mounting bracket) |

8.3. Available autotransformers

Standard autotransformers are available in either floor mount or wall mount configurations in the power range up to 20 kVA.

The tap marked „380“ is used for either 3x 380 V (+15% / -10%) or 3x 400V (+10% / -15%)(see dimensional data, section 7).

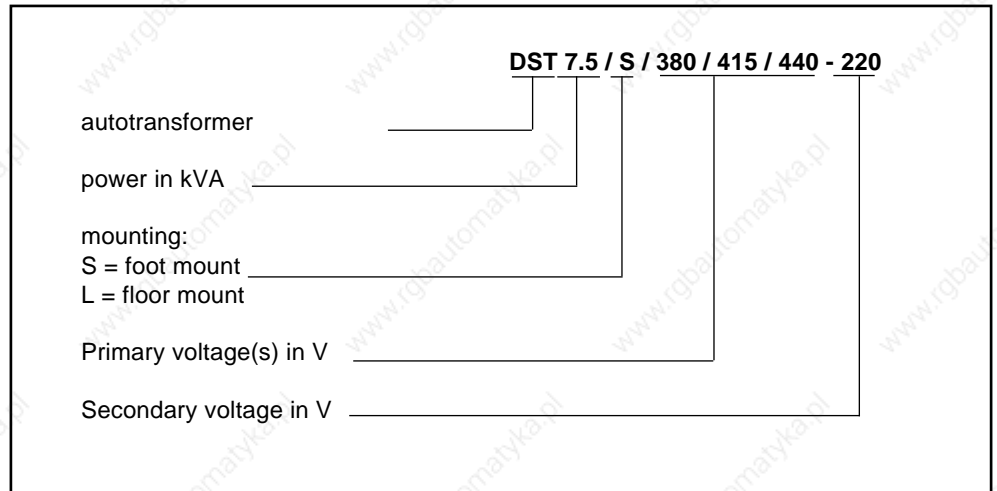

Figure 8.2: Type codes for autotransformers

Available configurations:

DST 0.5./380/415/440-220

DST 0.5./380/460/500-220

DST 1.0./380/415/440-220

DST 1.0./380/460/500-220

DST 1.5./380/415/440-220

DST 1.5./380/460/500-220

DST 2.0./380/415/440-220

DST 2.0./380/460/500-220

DST 2.5./380/415/440-220

DST 2.5./380/460/500-220

DST 3.5./380/415/440-220

DST 3.5./380/460/500-220

DST 4.0./380/415/440-220

DST 4.0./380/460/500-220

DST 5.0./380/415/440-220

DST 5.0./380/460/500-220

DST 7.5./380/415/440-220

DST 7.5./380/460/500-220

DST 10./380/415/440-220

DST 10./380/460/500-220

Autotransformer Available configurations:

DST 12.5/.380/415-220
 DST 12.5/.440/460-220
 DST 12.5/.500/525-220

DST 15/.380/415-220
 DST 15/.440/460-220
 DST 15/.500/525-220

DST 18/.380/415-220
 DST 18/.440/460-220
 DST 18/.500/525-220

DST 20/.380/415-220
 DST 20/.440/460-220
 DST 20/.500/525-220

DST 25/S/380/415-220
 DST 25/S/440/460-220
 DST 25/S/500/525-220

DST 35/S/380/415-220
 DST 35/S/440/460-220
 DST 35/S/500/525-220

DST 50/S/380/415-220
 DST 50/S/440/460-220
 DST 50/S/500/525-220

Other connection voltages available upon request.

8.4. Available isolation transformers

Standard isolation transformers are available in either floor mount or wall mount configurations in the power range up to 10kVA.

The tap marked „380“ is used for either 3x 380 V (+15% / -10%) or 3x 400V (+10% / -15%) (see dimensional data, section 7).

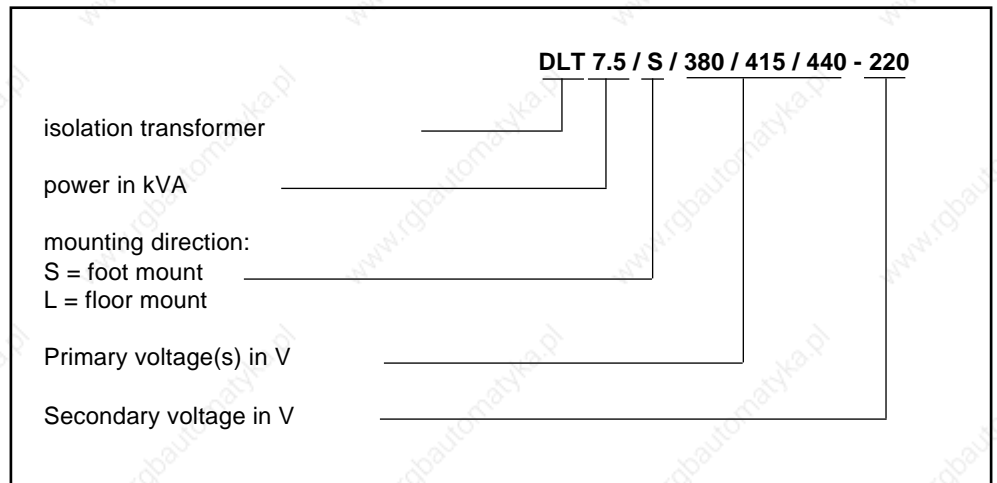

Figure 8.3: Type codes for isolation transformers

Isolation transformer **Available configurations:**

DLT 0.5./380/415/440-220

DLT 0.5./380/460/500-220

DLT 1.0./380/415/440-220

DLT 1.0./380/460/500-220

DLT 1.5./380/415/440-220

DLT 1.5./380/460/500-220

DLT 2.0./380/415/440-220

DLT 2.0./380/460/500-220

DLT 2.5./380/415/440-220

DLT 2.5./380/460/500-220

DLT 4.0./380/415/440-220

DLT 4.0./380/460/500-220

DLT 5.0./380/415/440-220

DLT 5.0./380/460/500-220

DLT 7.5./380/415/440-220

DLT 7.5./380/460/500-220

DLT 10./380/415/440-220

DLT 10./380/460/500-220

DLT 15/S/380-220

DLT 20/S/380-220

DLT 25/S/380-220

DLT 35/S/380-220

DLT 50/S/380-220

Other connection voltages available upon request.

8.5. Overview of electrical accessories

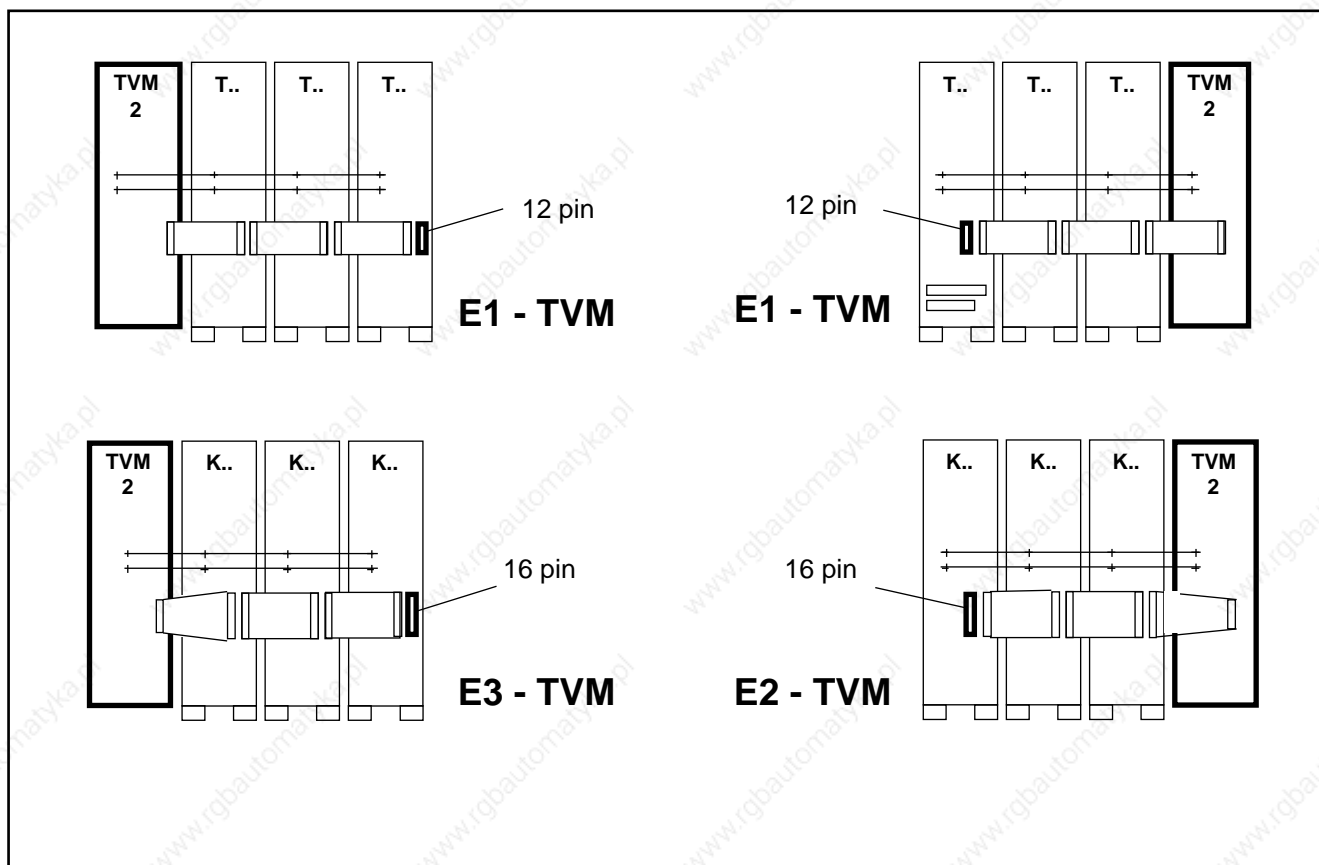

8.6. Order list for TVM 2.4 power supply module

Item	Article	For selection see
1.1	TVM 2.4-050-220/300-W1/.../...	section 8.2
1.2	electrical accessories E.-TVM	section 8.5
2.1	autotransformer DST ../.../...-220	section 2.1 and 8.3
3.1	add. bleeder (option) TBM 1.2-40-W1-024	section 2.1 and 8.2
4.1	add. capacitance (option) CZ 1.02 or TCM 1.1-...-W0	section 3.7 and 8.2
5.1	dynamic brake contactor L.1 D25 008..	section 8.2
5.2	Auxiliary block LA1 DN 22	
5.3	dynamic braking resistor	HLZ-300-07 Z

9. Index

Symbole

3-phase current DLT isolating transformer 51

A

Add. bleeder module 60
Additional bleeder 24, 43
Additional capacitance 13, 23
Additional components 10
Ambient conditions 12
Ambient temperature 12
Asynchronous motors 31
Available versions 56

B

Basic losses 29
Bb contact 38
Bb1 contact 8, 36, 38, 42
Bleeder losses 29
Buffer capacitance 8
Busbars 23

C

Cable cross sections 19
Connecting voltage 16
Connection accessories 23
Connection cross section 19
Continuous bleeder power 24
Continuous regenerated energy 24
Control 31
Control circuit 36
Control voltage 13
CZ 1.02 52

D

Diagnostics displays 46
Dimensional data 11, 49
Drive electronics 36, 38
Drive enable signal 32
Drive fault 36
Drive fault message 36
Drive module 7

E

Electronics power supply 8
Electrostatic loads 45
Energy storage 23
Error reactions 32

F

Fault causes 47
Fault current protective device 27
Fault-finding 44
Fault-location 44
Faults 48
Following error message 32
Foot mat 32
Frequency 16
Frontal view 30
Fuse protection 13
Fuses 48
Fusing 19

G

Ground wire 16
Grounded three-phase mains 22

H

Heat loss 29
Holding brakes 32

I

Installation 28
Installation altitude 12
Interface descriptions 42
Interference voltages 42
IT-mains 22

L

Light barriers 32
Limit switch 32, 38
Link circuit 23
Link circuit d.c. voltage 7
Link circuit dynamic braking 33, 36, 38
Link circuit dynamic braking contactor 54
Link circuit dynamic braking resistor 54
List of faults 47

M

Main switch 45
Mains connection 16
Mains contactor 32, 36
Making current 21, 38
Maximum permissible fusible links 19
Minimum clearance 29
Monitoring 8, 13

O

ON-button 36
Operating safety 22
Order information 56
Overvoltage 22

P

Peak bleeder power 24
Peak regenerated power 24
Power circuit breakers 19
Power losses 29
Power "ON" 47
Power ratings 10
Power rectifier 8
Power supply 8, 42, 47
Power supply requirements 22
Protecting the machine 45
Protecting the unit 45

R

Readiness 8
"Ready" state 42
Reference switch 33
Repairs 44

S

Safety clearances 29
Safety doors 32
Servicing 44
Servo error 36, 38
Signal exchange 26
Signal voltage 48
Signal voltage bus 8
Signal voltages 42
Single-phase autotransformer 55
Soft-start resistor 55
Supply module 7
Supplying the blower 25
Supplying the drive electronics 26
Supplying the electronics 25
Synchronous motors 31

T

TBM 1.2 53
TCM 1.1 52
TDM drive modules 38
Terminal connection diagram 14
Terminal plug 26, 48
Torque 38
Type codes 56

U

UL approbation 13
Ungrounded three-phase mains 22

V
Voltage matching 13

