

PowerXL™

DE1... – Variable speed starter

Variable Speed Starter VSS

DXE-EXT-SET – Configuration module



Powering Business Worldwide

DE1... Variable Speed Starter All proprietary names and product designations are brand names or trademarks registered to the relevant title holders.

Break-Down Service

Please call your local representative:

<http://eaton.com/moeller/aftersales>

or

Hotline After Sales Service:

+49 (0) 180 5 223822 (de, en)

AfterSalesEGBonn@eaton.com

For customers in US/Canada contact:

EatonCare Customer Support Center

Call the EatonCare Support Center if you need assistance with placing an order, stock availability or proof of shipment, expediting an existing order, emergency shipments, product price information, returns other than warranty returns, and information on local distributors or sales offices.

Voice: 877-ETN-CARE (386-2273) (8:00 a.m. – 6:00 p.m. EST)

After-Hours Emergency: 800-543-7038 (6:00 p.m. – 8:00 a.m. EST)

Drives Technical Resource Center

Voice: 877-ETN-CARE (386-2273) option 2, option 6

(8:00 a.m. – 5:00 p.m. Central Time U.S. [UTC-6])

email: TRCDrives@Eaton.com

www.eaton.com/drives

Original operating manual

The German-language edition of this document is the original operating manual.

Translation of the original operating manual

All editions of this document other than those in German language are translations of the original operating manual.

1. Edition 2014, publication date 09/14
2. Edition 2015, publication date 01/15
3. Edition 2015, publication date 05/15
4. Edition 2015, publication date 11/15
5. Edition 2016, publication date 02/16
6. Edition 2016, publication date 11/16
7. Edition 2017, publication date 04/17
8. Edition 2019, publication date 05/19

© 2014 by Eaton Industries GmbH, 53105 Bonn

Authors: Jörg Randermann, Heribert Joachim, Rainer Günzel, J. Berchtold

Redaction: René Wiegand

All rights reserved, also for the translation.

No part of this manual may be reproduced, stored in a retrieval system, or transmitted in any form or by any means, electronic, mechanical, photocopying, micro-filming, recording or otherwise, without the prior written permission of Eaton Industries GmbH, Bonn.

Subject to alteration.



Danger! **Dangerous electrical voltage!**

Before commencing the installation

- Disconnect the power supply of the device.
- Ensure that devices cannot be accidentally retriggered.
- Verify isolation from the supply.
- Ground and short-circuit.
- Cover or enclose neighbouring units that are live.
- Follow the engineering instructions (IL) of the device concerned.
- Only suitably qualified personnel in accordance with EN 50110-1/-2 (VDE 0105 Part 100) may work on this device/system.
- Before installation and before touching the device ensure that you are free of electrostatic charge.
- The functional earth (FE) must be connected to the protective earth (PE) or to the potential equalizing. The system installer is responsible for implementing this connection.
- Connecting cables and signal lines should be installed so that inductive or capacitive interference do not impair the automation functions.
- Install automation devices and related operating elements in such a way that they are well protected against unintentional operation.
- Suitable safety hardware and software measures should be implemented for the I/O connection so that a cable or wire breakage on the signal side does not result in undefined states in the automation device.
- Ensure a reliable electrical isolation of the low voltage for the 24 V supply. Only use power supply units complying with IEC 60364-4-41 or HD 384.4.41 S2 (VDE 0100 part 410).
- Deviations of the mains voltage from the nominal value must not exceed the tolerance limits given in the technical data, otherwise this may cause malfunction and dangerous operation.
- Emergency-Stop devices complying with IEC/EN 60204-1 must be effective in all operating modes of the automation devices. Unlatching the emergency switching off devices must not cause restart.
- Built-in devices for enclosures or cabinets must only be run and operated in an installed state, desk-top devices or portable devices only when the housing is closed.
- Measures should be taken to ensure the proper restart of programs interrupted after a voltage dip or failure. This should not cause dangerous operating states even for a short time. If necessary, emergency switching off devices should be implemented.
- Wherever faults in the automation system may cause damage to persons or property, external measures must be implemented to ensure a safe operating state in the event of a fault or malfunction (for example, by means of separate limit switches, mechanical interlocks, etc.).
- During operation, and depending on their degree of protection, variable frequency drives may have live, uninsulated, moving, and/or rotating parts, as well as hot surfaces.
- The impermissible removal of the required cover, improper installation or incorrect operation of the motor or variable frequency drive can cause the failure of the device and serious injury and/or material damage.
- Comply with all applicable national accident prevention regulations (e.g. BGV A3) when working with energized variable frequency drives.
- The electrical installation must be carried out in accordance with the relevant regulations (e.g. with regard to cable cross sections, fuses, PE).
- All transport, installation, commissioning and maintenance work must only be carried out by trained personnel (observe IEC 60364, HD 384 or DIN VDE 0100 and national accident prevention regulations).
- If applicable, systems in which variable frequency drives are installed must be equipped with additional monitoring and protective devices in accordance with the applicable safety regulations, e.g., the German Equipment and Product Safety Act, accident prevention regulations, etc. Making changes to the variable frequency drives by using the operating software is allowed.
- Keep all covers and doors closed during operation.
- When designing the machine, the user must incorporate mechanisms and measures that limit the consequences of a drive controller malfunction or failure (an increase in motor speed or the motor's sudden stop) so as to prevent hazards to people and property, e.g.:
 - Additional stand-alone devices for monitoring parameters that are relevant to safety (speed, travel, end positions, etc.)
 - Electrical and non-electrical safety devices (interlocks or mechanical locks) for mechanisms that protect the entire system
 - Due to the possibility of there being capacitors that are still holding a charge, do not touch live device parts or terminals immediately after disconnecting the variable frequency drives from the supply voltage. Heed the corresponding labels on the variable frequency drives

Content

0	About this manual	5
0.1	Target group.....	5
0.2	List of revisions	5
0.2.1	Additional documents	6
0.3	Writing conventions	7
0.3.1	Hazard warnings of material damages	7
0.3.2	Hazard warnings of personal injury	7
0.3.3	Tips.....	7
0.4	Abbreviations	8
0.5	Mains supply voltages.....	9
0.6	Units of measurement	9
1	DE1... series	9
1.1	Introduction	9
1.2	System overview	11
1.3	Checking the Delivery	12
1.4	Rated operational data	13
1.4.1	Rating data on the nameplate	14
1.4.2	Designation	15
1.5	Designation	16
1.6	Voltage categories.....	17
1.7	Selection criteria.....	18
1.8	Proper use.....	19
1.9	Maintenance and inspection	20
1.10	Storage.....	20
1.11	Charging the internal DC link capacitors	21
1.12	Service and warranty.....	21
2	Engineering.....	23
2.1	Introduction	24
2.2	Electrical power network	25
2.2.1	Mains connection and configuration	25
2.2.2	Mains voltage and frequency	26
2.2.3	Total Harmonic Distortion (THD)	26
2.2.4	Reactive power compensation.....	27
2.3	Safety and switching.....	28
2.3.1	Disconnecting device	28
2.3.2	Fuses and cable cross-sections	28
2.3.3	Residual current circuit-breaker (RCD)	29
2.3.4	Mains contactors.....	30
2.3.5	Using a bypass connection	30

2.4	EMC measures	31
2.5	Motor Selection	33
2.5.1	Parallel connection of motors	33
2.5.2	Circuit types with three-phase motors.....	34
2.5.3	Connecting EX motors	34
3	Installation.....	35
3.1	Introduction.....	35
3.2	Mounting	35
3.2.1	Mounting position	36
3.2.2	Free space	36
3.2.3	Fixing	38
3.3	Electrical Installation	40
3.3.1	Insulation test	41
3.3.2	Connection to power section.....	42
3.3.3	Earthing.....	45
3.3.4	EMC jumper.....	46
3.3.5	Motor connection.....	48
3.3.6	Installations meeting UL® requirements.....	50
3.3.7	Connection to control section	51
3.4	RJ 45 interface.....	59
3.5	LED indicators.....	61
3.6	Block diagrams.....	63
3.6.1	DE1...-12...FN-.....	63
3.6.2	DE1...-12...NN-.....	63
3.6.3	DE1...-34...FN-.....	64
3.6.4	DE1...-34...NN-.....	64
4	Operation.....	65
4.1	Checklist for commissioning.....	65
4.2	Hazard warnings for operation	66
4.3	Protection against electric shock	68
4.4	Commissioning with default settings	69
5	DXE-EXT-SET configuration module	71
5.1	DXE-EXT-SET designation.....	71
5.2	Plugging the module into / removing it from a DE1... variable speed starter	72
5.3	Description and use	73

6	Parameter	79
6.1	RJ45 interface	80
6.2	DX-KEY-LED2 external keypad.....	81
6.2.1	Key combinations.....	83
6.2.2	Parameter structure	84
6.2.3	Setting parameters.....	85
6.3	drivesConnect	86
6.4	SmartWire-DT	87
6.5	Parameter description	88
6.5.1	Acceleration and deceleration time.....	88
6.5.2	Motor data.....	91
6.5.3	Motor protection	93
6.5.4	V/f characteristic curve.....	96
6.5.5	DC braking.....	99
6.5.6	Control terminal configuration.....	100
6.6	Parameter lock	111
6.7	Default settings.....	112
6.8	Displaying operational data	113
7	Modbus RTU und CANopen bus systems	115
7.1	Modbus RTU.....	115
7.2	CANopen.....	115
8	Technical Data	117
8.1	Features	117
8.2	General rating data	118
8.3	Rating data	119
8.3.1	DE1...-12... (single-phase mains connection)	119
8.3.2	DE1...-34... (three-phase mains connection)	123
8.4	Dimensions	129
9	Accessory devices	131
9.1	DX-KEY-LED2 external keypad and DX-KEY-OLED	131
9.2	DX-COM-STICK3 communications stick	134
9.3	SmartWire-DT DX-NET-SWD3	136
9.4	DX-CBL-PC3M0 computer cable.....	137
9.5	Cable and safety devices	138
9.6	DIL... mains contactors.....	141
9.7	DX-LN... mains chokes	142
9.8	External EMC filter	144
9.9	Motor Choke DX-LM3...	146

10	Fault messages	149
10.1	Acknowledge fault message (Reset)	150
10.2	Fault log	150
10.3	Fault list.....	152
11	List of parameters.....	155
	Index	167

0 About this manual

This manual contains specific information that will enable you to select a DE1... variable speed starter, connect it, and use its parameters to configure it as required for your specific needs if necessary. The manual applies to all DE1... models, and also describes the DXE-EXT-SET optional configuration module. Any differences between and special characteristics of the various models will be noted accordingly.

All specifications refer to firmware version 1.05.

0.1 Target group

This MN040011EN manual is intended for engineers and electricians. Electrical engineering and physics-related knowledge and skills will be required in order to be able to commission the corresponding devices. We assume that you have a good knowledge of engineering basics and that you are familiar with handling electrical systems and machines, as well as with reading technical drawings.

0.2 List of revisions

The following significant amendments have been introduced since previous issues:

Publication date	Page	Keyword	new	modified	deleted
05/19	19	Directives		✓	
	45	Tightening torque		✓	
	–	Three-phase commoning link			✓
	68	Protection against electric shock	✓		
	101	ENA, MOR	✓		
	–	DX-COM-PCKIT			✓
	120, 123, 126	Heat dissipation		✓	
	various	DX-KEY-LED → DX-KEY-LED2		✓	
	various	DX-COM-STICK → DX-COM-STICK3		✓	
04/17	various	Firmware version 1.05		✓	
	–	Splitter DX-SPL-RJ45-2SL1PL			✓
	various	Parameters		✓	
11/16	102, 106, 107	P12 = 12			✓
02/16	157	Parameter P-12		✓	
	163	Parameter P-50	✓		
11/15	various	New DE11 device version	✓		
		Chapter "Modbus RTU"			✓
05/15	various	Section "Sine filter" and corresponding text passages			✓
01/15	144	External EMC filter	✓		
09/14		Initial issue			

0 About this manual

0.2 List of revisions

0.2.1 Additional documents

For further information, see the following documentation:

- MN040018 manual: "Modbus RTU – Communication manual for DA1, DC1, DE1 variable frequency drives"
- MN040019 manual: "CANopen – Communication manual for DA1, DC1, DE11 variable frequency drives"
- Instruction leaflet IL040005ZU:
"DE1-12..., DE1-34..., DE11-12..., DE11-34..."
- Instruction leaflet IL040020ZU: "DXE-EXT-SET"
- Application Note AP040092 Quick-Start-Guide: "DE1"
- Application Note AP040033 Quick-Start-Guide: "DE11"

0.3 Writing conventions

Symbols with the following meaning are used in this manual:

- ▶ Indicates instructions to be followed.

0.3.1 Hazard warnings of material damages

NOTICE

Warns about the possibility of material damage.

0.3.2 Hazard warnings of personal injury



CAUTION

Warns of the possibility of hazardous situations that may possibly cause slight injury.



WARNING

Warns of the possibility of hazardous situations that could result in serious injury or even death.



DANGER

Warns of hazardous situations that result in serious injury or death.

0.3.3 Tips



Indicates useful tips.



The variable speed starter's housing, as well as other safety-relevant parts, has been left out in some of the images in this manual in order to make the images easier to understand. However, it is important to note that the variable speed starter must always be operated with its housing in its proper place, as well as with all required safety-relevant parts.



All the specifications in this manual refer to the hardware and software versions documented in it.



More information on the devices described here can be found on the Internet under:

www.eaton.eu/powerxl

www.eaton.eu/documentation

0.4 Abbreviations

The following abbreviations are used in this manual:

Table 1: Acronyms and abbreviations

Abbreviation	Meaning
DS	Default settings
EMC	Electromagnetic compatibility
FE	Functional earth
FS	Frame Size
FWD	Forward run (clockwise rotating field)
GND	Ground (0-V-potential)
hex	Hexadecimal (base-16 numeral system)
ID	Identifier (unique ID)
IGBT	Insulated gate bipolar transistor
LED	Light Emitting Diode (LED)
PC	Personal Computer
PDS	Power Drive System
PE	Protective earth \oplus
PES	Protective earth shield (PE connection for screened cables)
PNU	Parameter number
REV	Reverse run (anticlockwise rotation field active)
RMS	Root Mean Square
ro	Read Only (read access only)
rw	Read/Write (read/write access)
SCCR	Short Circuit Current Rating
UL®	Underwriters Laboratories
VSS	Variable Speed Starter

0.5 Mains supply voltages

The rated operating voltages stated in the following table are based on the nominal values for networks with an earthed star point.

In ring networks (as found in Europe) the rated operating voltage at the transfer point of the power supply companies is the same as the value in the consumer networks (e.g. 230 V, 400 V).

In star networks (as found in North America), the rated operating voltage at the transfer point of the utility companies is higher than in the consumer network.

For example: 240 V → 230 V, 480 V → 460 V.

Accordingly, the DE1... variable speed starter's wide tolerance range allows for a permissible voltage drop of 10 % (i.e., $U_{LN} - 10\%$) and, in the 400-V category, takes into account a North American mains voltage of $480\text{ V} + 10\%$ (60 Hz).

The permissible power supply for the DE1... series is listed in the technical data section in the annex.

The rated mains voltage operational data is always based on mains frequencies of 50/60 Hz within a range of 48 to 62 Hz.

0.6 Units of measurement

Every physical dimension included in this manual uses international metric system units, otherwise known as SI (Système International d'Unités) units. For the purpose of the equipment's UL certification, some of these dimensions are accompanied by their equivalents in imperial units.

Table 2: Unit conversion examples

Designation	SI value	Imperial unit	Conversion value	US-American designation
Length	25.4 mm	1 in (")	0.0394	inch
Power	0.7457 kW	1 HP = 1.014 PS	1.341	horsepower
Torque	0.113 Nm	1 lbf in	8.851	pound-force inches
Temperature	-17.222 °C (T_C)	1 °F (T_F)	$T_F = T_C \times 9/5 + 32$	Fahrenheit
Rotational speed	1 min ⁻¹	1 rpm	1	Revolutions per minute
Weight	0.4536 kg	1 lb	2.205	pound
Flow rate	1.698 m ³ /min	1 cfm	0.5889	cubic feed per minute

0 About this manual

0.6 Units of measurement

1 DE1... series

1.1 Introduction

Ease of use and high reliability make PowerXL™ DE1... variable speed starters the ideal choice for general applications involving three-phase motors. These variable speed starters close the gap between conventional DOL starters and variable frequency drives. In fact, they combine the advantages of both device types in a single device by providing the ease of use of a DOL starter and the variable motor speed of a variable frequency drive. Among other things, this makes it possible to ensure a soft motor start that uses configured time parameters to take a motor to a defined speed with full torque while avoiding inrush current peaks, enabling users to achieve the energy efficiency required for their applications (in compliance with the ErP Directive). In addition to this, DE1... variable speed starters feature variable speed control (U/f control), reversing duty capabilities (reversing starter), controlled drive stopping based on configured time parameters, and the option of easily switching between functions using control signal terminals.

DE1... variable speed starters are characterized by a compact and heavy-duty design and are available in two sizes and within a performance range of 0.25 kW (with 230 V) to 7.5 kW (with 400 V). They feature an integrated radio interference suppression filter and a serial interface that, when combined with the same fast and cost-effective mounting and commissioning that conventional DOL starters are known for, allows them to meet the vital production and manufacturing process optimization needs of the machine building industry (MOEM).

The extensive accessories available for the DE1 series further enhance the latter's versatility in a wide variety of applications. For example, the simple and easy-to-use DXE-EXT-SET configuration module makes it possible to make custom changes and adjustments using a screwdriver. There is also the PC-based drivesConnect parameter software, which helps prevent data loss, makes it possible to make custom changes and adjustments, and reduces the time it takes to commission and maintain a DE1 device.

1 DE1... series
1.1 Introduction

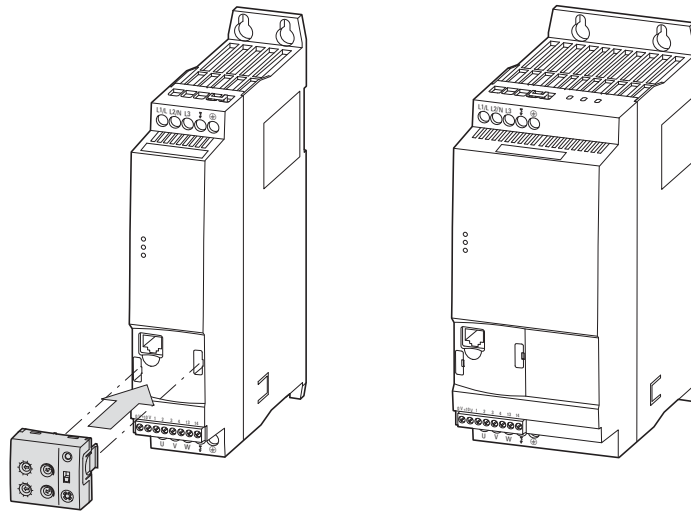


Figure 1: DE1... housing versions (left: 45 mm, right: 90 mm) and optional DXE-EXT-SET configuration module

1.2 System overview

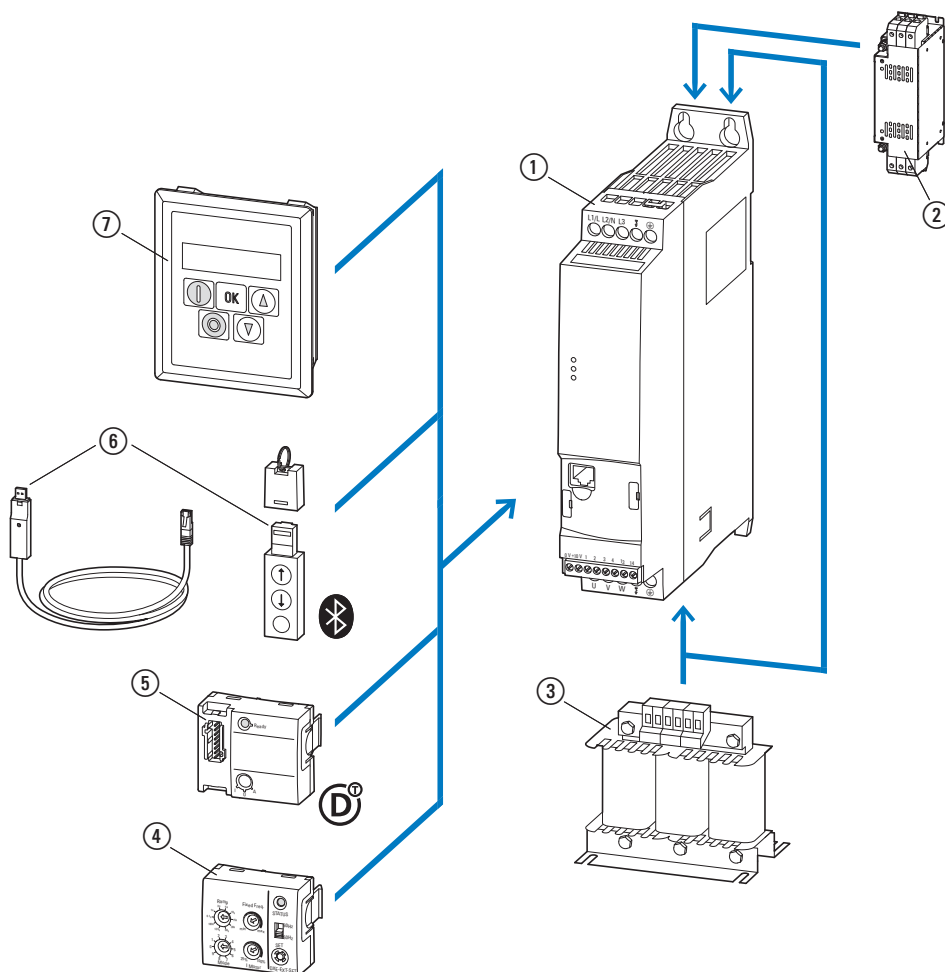


Figure 2: System overview (example)

- ① DE1...-... variable speed starters
- ② External radio interference suppression filter DX-EMC...
- ③ DX-LN... mains choke, DX-LM3-... motor choke
- ④ DXE-EXT-SET configuration module
- ⑤ DX-NET-SWD3 SmartWire-DT interface
- ⑥ DX-COM-STICK3 communication module and accessories (e. g. DX-CBL-... connection cable)
- ⑦ DX-KEY-... keypad (external)

1 DE1... series

1.3 Checking the Delivery

1.3 Checking the Delivery



Before opening the package, please check the nameplate on it to make sure that you received the correct variable speed starter.

The DE1... series variable speed starter are carefully packed and prepared for shipment. The devices should be shipped only in their original packaging with suitable transportation materials. Please take note of the labels and instructions on the packaging, as well as of those meant for the unpacked device.

Open the packaging with adequate tools and inspect the contents immediately after receipt in order to ensure that they are complete and undamaged.

The packaging must contain the following parts:

- A DE1... variable speed starter,
- an instruction leaflet IL040005ZU.

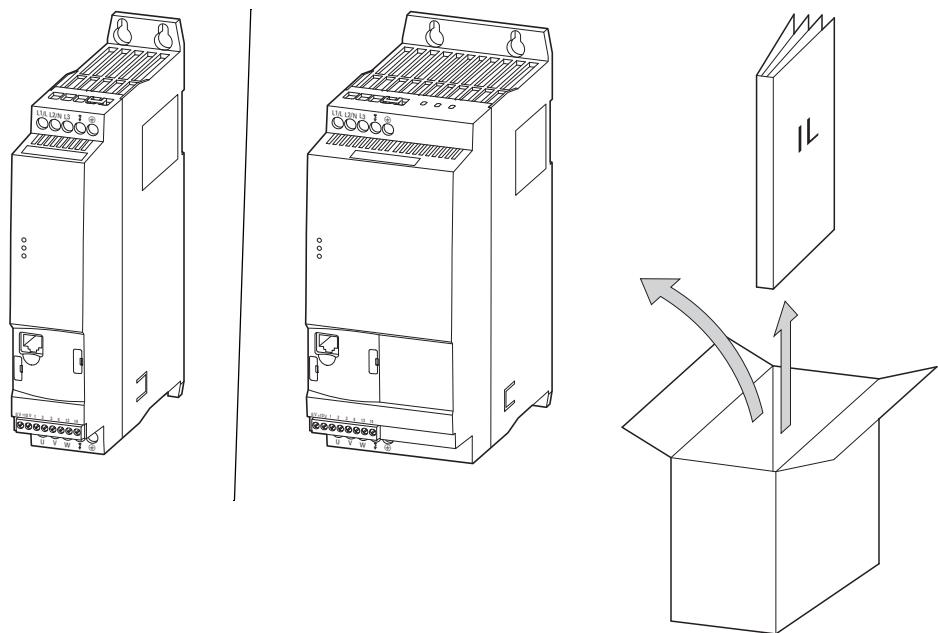


Figure 3: Equipment supplied:
DE1 variable speed starter with a size of 45 mm or 90 mm
and instruction leaflet IL040005ZU

1.4 Rated operational data

The device-specific rated operational data for the DE1... variable speed starter is listed on the nameplate on the right side of the device.

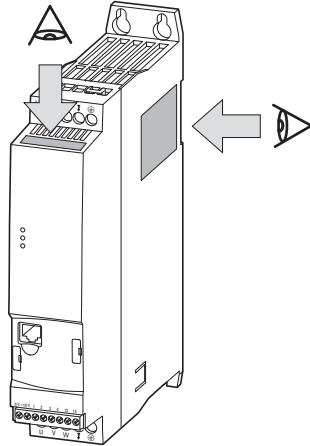


Figure 4: Nameplate location

The nameplate on top (nameplate B) is a simplified version that can be used to clearly identify the device if the main nameplate (nameplate A) is blocked by other devices.

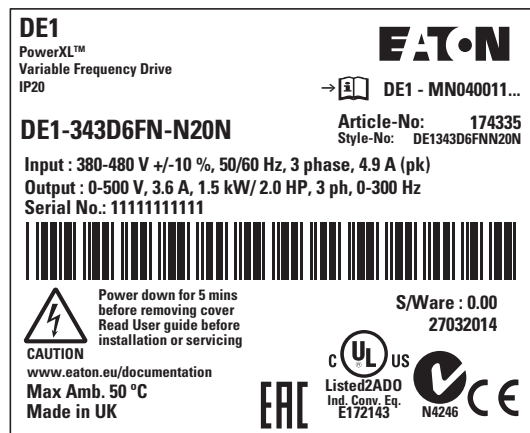


Figure 5: Nameplate A (on the side)

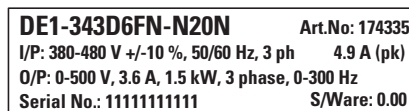



Figure 6: Nameplate B (on the front)

1 DE1... series

1.4 Rated operational data

1.4.1 Rating data on the nameplate

The inscription of the nameplates has the following meaning (example):

Inscription	Meaning
DE1-343D6FN-N20N	Part no.: DE1 = DE1 variable speed starter 3 = Three-phase mains connection / three-phase motor connection 4 = 400 V mains voltage category 3D6 = Rated operational current (3-decimal point-6, output current) F = integrated RFI filter N = No internal brake chopper N = No display (keypad) 20 = IP20 degree of protection N = basic device
Article-No: Style-No:	174335 = Article no. for variable speed starter DE1-343D6FN-N20N DE1343D6FNN20N = Article no./order designation in the USA
I/P (Input):	Rated operational data of mains connection 380 - 480 V ± 10 % (three-phase alternating voltage) 50 - 60 Hz (mains frequency) 3 phase, 4.9 A (Input phase current)
O/P (Output):	Load side (motor) rated operational data: 0 - 500 V (three-phase alternating voltage) 3.6 A (output phase current) 1.5 kW / 2 hp (rated motor output) 3-phase, 0 - 300 Hz
Serial No.:	Serial number
	DE1 variable speed starters are electrical equipment. Read the manual (in this case MN040011EN) before making any electrical connections and commissioning.
Variable Frequency Drive	Variable speed starter with variable output frequency (VSS)
IP20	Degree of protection of the enclosure: IP20
Software:	0.00, software version
Max amb. 50 °C	Maximum permissible ambient air temperature: 50 °C (without derating/output reduction)
27032014	Manufacturing date: 03-27-2014

1.4.2 Designation

The catalog number selection/part no. for DE1 variable speed starters is subdivided into three groups

Series – Power section – Model – (Versions)

The following figure shows it in greater detail:

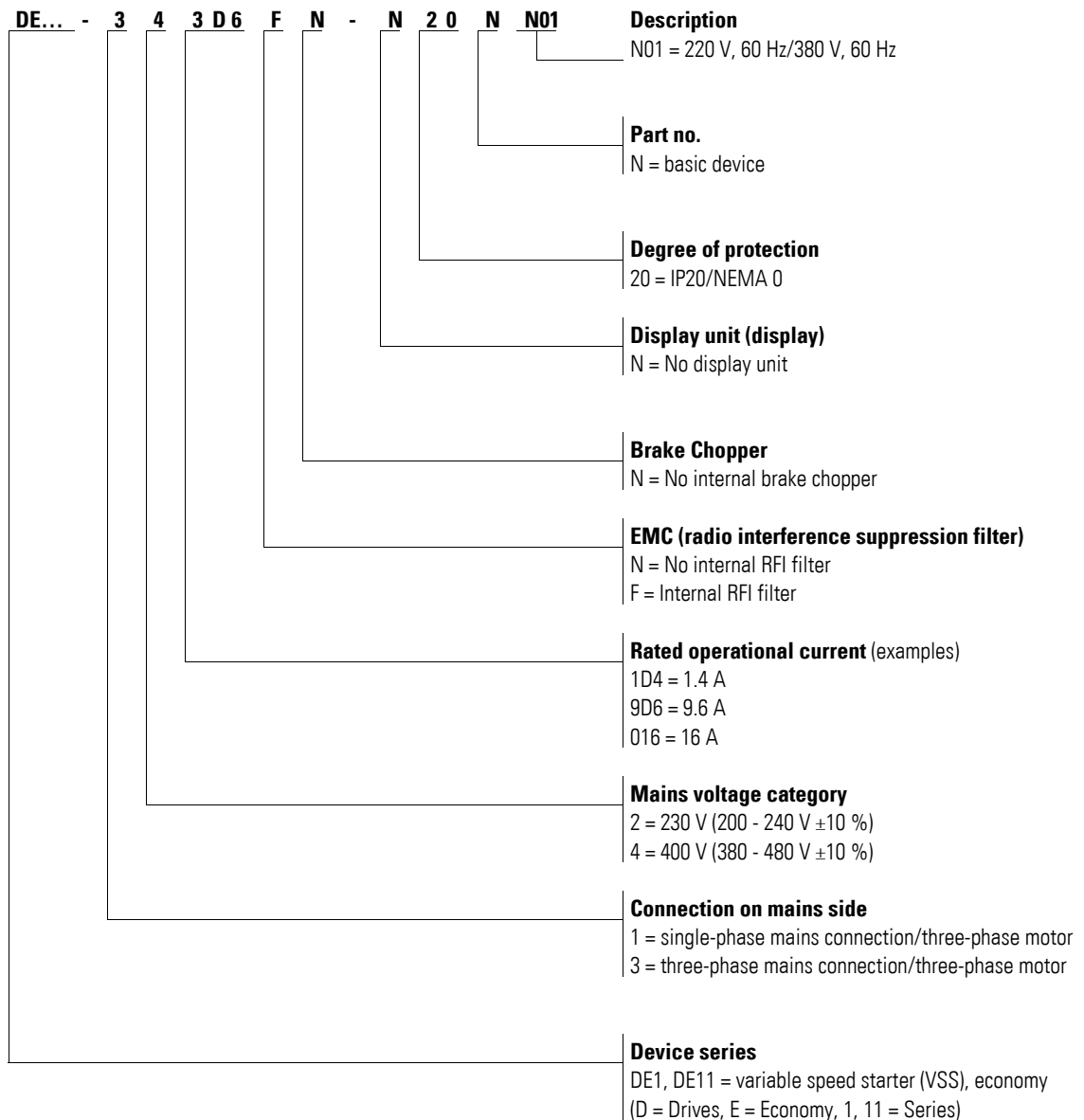


Figure 7: Designation

1.5 Designation

The following drawing shows an example of the physical configuration of a DE1... variable speed starter with a size of 90 mm.

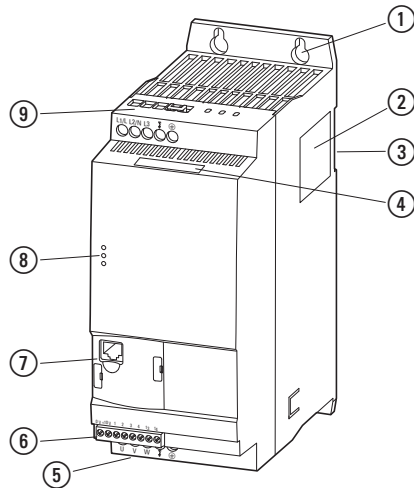


Figure 8: Designation (width: 90 mm)

- ① Fixing holes (screw fastening)
- ② Nameplate
- ③ Cutout for mounting on a mounting rail
- ④ Nameplate (simplified version)
- ⑤ Connection terminals in power section (motor feeder)
- ⑥ Control signal terminals
- ⑦ Communication interface and slot for DXE-EXT-SET or DX-NET-SWD3
- ⑧ LED operating signals
- ⑨ Connection terminals in power section (mains side)

1.6 Voltage categories

DE1... variable speed starters are subdivided into two voltage categories:

- DE1...-12...
 - Single-phase mains connection 230 V
 - $U_{LN} = 1\sim, 200 - 240 \text{ V} \pm 10 \%$, 50/60 Hz
 - I_e : 1.4 - 9.6 A
 - Motor: 0.25 - 2.2 kW (230 V), 1/3 - 3 hp (230 V)

Mains, $U_{LN} = 1 \sim 200 - 240 \text{ V} \pm 10 \%$

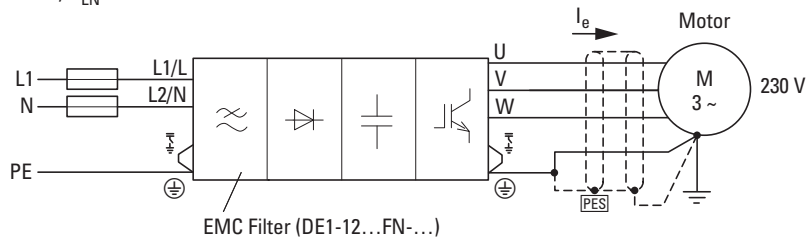


Figure 9: DE1...-12...FN-N20N (with radio interference suppression filter)

Mains, $U_{LN} = 1 \sim 200 - 240 \text{ V} \pm 10 \%$

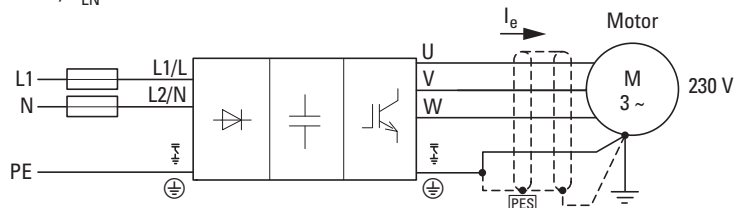


Figure 10: DE1...-12...NN-N20N (without radio interference suppression filter)

- DE1...-34...
 - three-phase mains connection 400 V
 - $U_{LN} = 3\sim, 380 - 480 \text{ V} \pm 10 \%$, 50/60 Hz
 - I_e : 1.3 - 16 A
 - Motor: 0.37 - 7.5 kW (400 V), 1/2 - 10 HP, (460 V)

Mains, $U_{LN} = 3 \sim 380 - 480 \text{ V} \pm 10 \%$

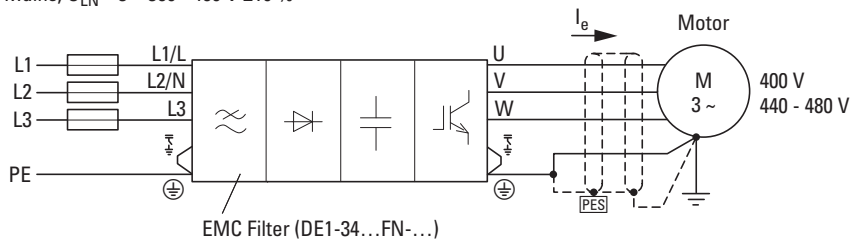


Figure 11: DE1...-34...FN-N20N (with radio interference suppression filter)

Mains, $U_{LN} = 3 \sim 380 - 480 \text{ V} \pm 10 \%$

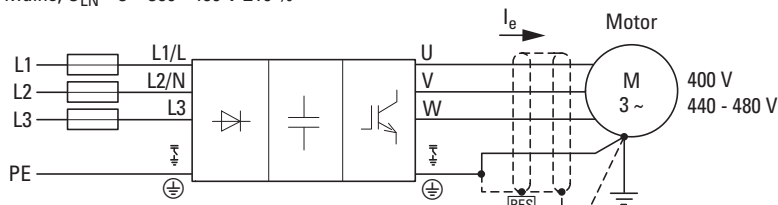


Figure 12: DE1...-34...NN-N20N (without radio interference suppression filter)

1.7 Selection criteria

DE1... variable speed starters should be selected based on the supply voltage provided by the mains (U_{LN}) and the rated operational current of the motor being used. The motor's configuration (Δ / Υ) must match the supply voltage.

The DE1... variable speed starter's rated output current I_e must be greater than or equal to the rated motor current.

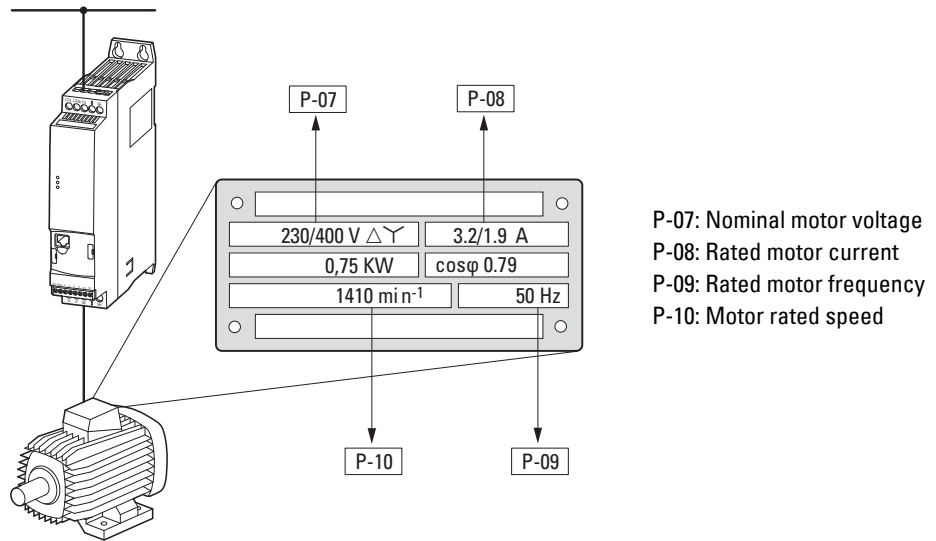


Figure 13: Selection criteria

When selecting a variable speed starter, the following criteria must be known:

- Mains voltage = The motor's rated operating voltage
- Type of motor (e.g., three-phase asynchronous motor)
- The rated motor current (point of reference – depends on the motor's configuration and on the power supply)
- Ambient conditions (ambient temperature for DE1..., required degree of protection)

Example based on figure 13

- Mains voltage: 3~ 400 V, 50 Hz
- Centrifugal pump motor
- Star-connected circuit (400 V)
- Rated operational current: 1.9 A (400 V)
- Enclosure installation
(Max. ambient temperature of 50 °C without output reduction, IP20)

→ Variable speed starter that should be selected: DE1-342D1...

- ...-34: 3-phase, 400 V
- ...2D1: 2.1 A (1.9 A rated motor current)

1.8 Proper use

The DE1... variable speed starters are not domestic appliances. They are designed only for industrial use as system components.

The DE1... variable speed starters are electrical devices for controlling variable speed drives with three-phase motors. They are designed for installation in machines or for use in combination with other components within a machine or system.

If the variable speed starter is installed in a machine, it is prohibited to place it into operation until it has been determined that the corresponding machine meets the safety and protection requirements set forth in Machinery Safety Directive 2006/42/EC (e.g., by complying with EN 60204). The user is responsible for ensuring the machine application's compliance with EC Directives.

The CE marking on DE1 variable speed starters confirms that the devices, when used in a typical drive configuration, comply with the European Union's Low Voltage (Low-Voltage Directive 2014/35/EC) and EMC Directives (EMC 2014/30/EC, and RoHS 2011/65/EU).

When used with the described system configuration, DE1... variable speed starters are suitable for use with public and private electrical power networks.

Connecting a DE1... variable speed starter to an IT network (network without a direct connection to earth potential) is only permissible under certain conditions, as the device's internal filter capacitors will connect the network to earth potential (enclosure).

In unearthed networks, this can result in hazardous situations or damage to the device (insulation monitoring is required!).



Do not do the following at the DE1... variable speed starter's output (terminals U, V, W):

- connect a voltage or capacitive loads (e.g. phase compensation capacitors),
- Connect multiple variable speed starters to each other in parallel
- make a direct connection to the input (bypass).

Always observe the technical data and connection conditions!
The corresponding information can be found on the variable speed starter's rating plate and in the relevant documentation. Any other use will be considered to be an improper use of the device.

1.9 Maintenance and inspection

DE1... variable speed starters are maintenance-free, provided that the general rating data, as well as the technical data for the specific models in use, is observed. However, please note that external influences can affect a variable speed starter's operation and lifespan.

Because of this, we recommend inspecting the devices on a regular basis and carrying out the following maintenance activities at the specified intervals.

Table 3: Recommended maintenance activities for DE1... variable speed starters

Maintenance measures	Maintenance interval
Clean cooling vents (cooling slits)	as needed
Check that the fan is working properly	6 - 24 months (depending on the environment)
Check the filter in the control panel doors (see the manufacturer's specifications)	6 - 24 months (depending on the environment)
Check all ground connections to make sure they are intact	On a regular basis, at periodic intervals
Check the tightening torques of the connections (control signal terminals, power terminals)	On a regular basis, at periodic intervals
Check connection terminals and all metallic surfaces for corrosion	6 - 24 months; when stored, no more than 12 months later (depending on the environment)
Motor cables and shield connection (EMC)	According to manufacturer specifications, no later than 5 years
Charge capacitors	12 months (→ section 1.11, "Charging the internal DC link capacitors")

The DE1... variable speed starter's components are not designed to be individually replaced or repaired. If a DE1... variable speed starter is ruined by external influences, it will not be possible to repair it!

Dispose of the device according to the applicable environmental laws and provisions for the disposal of electrical or electronic devices.

1.10 Storage

If the DE1... variable speed starter is stored before use, suitable ambient conditions must be ensured at the site of storage:

- Storage temperature: -40 - +70 °C,
- Relative average air humidity: < 95 %, non condensing (EN 61800-5-1),
- To prevent damage to the variable speed starter's internal DC link capacitors, it is not recommended to store the variable speed starter for more than 12 months (→ section 1.11, "Charging the internal DC link capacitors").

1.11 Charging the internal DC link capacitors

The DE1-12... variable speed starter's DC link features electrolytic capacitors. After prolonged storage or non-operation periods (> 12 months) without being powered, these DC link capacitors must be charged in a controlled manner in order to prevent damage to them. To do this, the DE1...-12... variable speed starter must be powered with a regulated DC power supply unit using both the L1/L and L2/N mains connection terminals. The variable speed starter must not have an active enable signal during the process (i.e., make sure that there is no active start signal).

The maximum charging voltage should reach the DC link voltage ($U_{DC} \sim 1.41 \times U_e$).

- DE1...-12...: approx. 324 V DC for $U_e = 230$ V AC



DE1...-34... variable speed starters do not require their capacitors to be reformed with the procedure described above ("lean DC link").

1.12 Service and warranty

In the unlikely event that you experience a problem with your DE1... variable speed starter, please contact your local sales office.

When you call, have the following data ready:

- The variable speed starter's exact part no. (→ refer to the nameplate)
- Serial number (→ refer to the nameplate)
- the date of purchase,
- A detailed description of the problem that occurred when running the variable speed starter

If some of the information printed on the nameplate is not legible, please state only the data which are clearly legible.

Information concerning the guarantee can be found in the Terms and Conditions Eaton Industries GmbH.

Break-Down Service

Please contact your local office:

<http://www.eaton.eu/aftersales>

or

Hotline After Sales Service

+49 (0) 180 5 223822 (de, en)

AfterSalesEGBonn@eaton.com

1 DE1... series

1.12 Service and warranty

2 Engineering

This chapter contains instructions that must be followed when determining which device to use with which rated motor output, as well as when selecting protection devices and switchgear, selecting cables, cable entries, and operating the DE1... variable speed starter.

All applicable laws and local standards must be complied with when planning and carrying out the installation. Not following the recommendations provided may result in problems what will not be covered by the warranty.

2.1 Introduction

This section describes the most important characteristics of the power circuit for a Power Drive System (PDS) that need to be taken into account when planning and configuring your application.

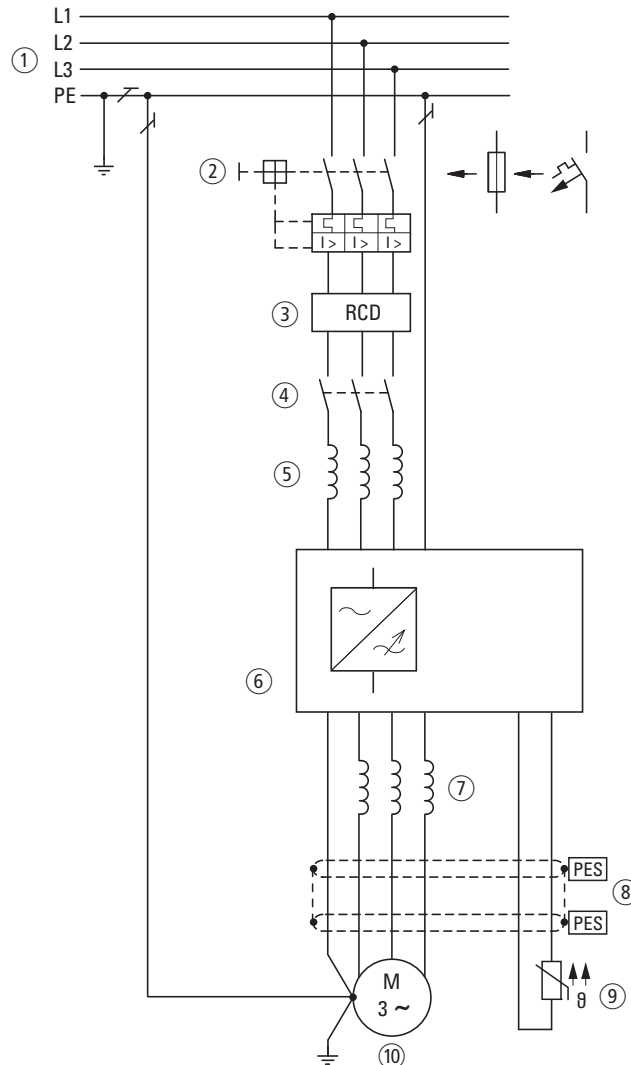


Figure 14: Example of a Power Drive System with a three-phase feeder unit for a three-phase motor

- ① Network configuration, mains voltage, mains frequency, interaction with p.f. correction systems
- ② Fuses and cable cross-sections, cable protection
- ③ RCD, Residual current device
- ④ mains contactor
- ⑤ Mains choke; if applicable, external radio interference suppression filter, line filter
- ⑥ Variable speed starter: mounting, installation; Power connection; EMC measures; Example of circuits
- ⑦ Motor choke, dV/dt filter
- ⑧ Cable lengths, motor cables, shielding (EMC)
- ⑨ Motor protection, thermistor
- ⑩ Motor and application, parallel operation of multiple motors on a variable speed starter, bypass circuit; DC braking

2.2 Electrical power network

2.2.1 Mains connection and configuration

DE1... variable speed starters can be connected to and run on all neutral point-grounded AC supply systems (TN-S, TN-C, TT grounding systems; please refer to IEC 60364) without any limitations.

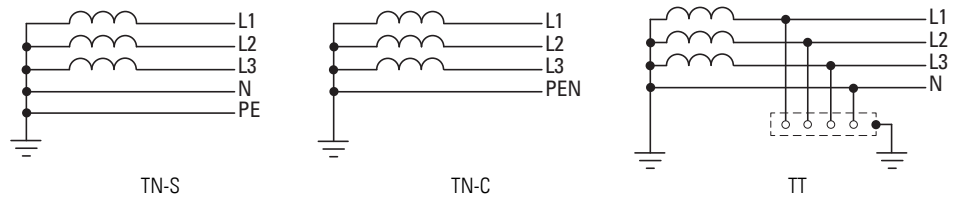


Figure 15: AC supply systems with earthed center point



While planning the project, consider a symmetrical distribution to the three main phase conductors, if multiple variable speed starters with single-phase supplies are to be connected. The total current of all single phase consumers is not to cause an overload of the neutral conductor (N-conductor).

The connection and operation of variable speed starters to asymmetrically grounded TN networks (phase-grounded Delta network "Grounded Delta", USA) or non-grounded or high-resistance grounded (higher than 30 Ω) IT networks is only conditionally permissible.



Operation on non-earthed networks (IT) requires the use of suitable insulation monitors (e.g. pulse-code measurement method).



In networks with an earthed phase conductor, the maximum phase-earth voltage must not exceed 300 V AC.

If DE1 variable speed starters with an internal radio interference suppression filter (DE1...-...FN-...) are connected to a corner-earthed network or an IT network (non-earthed, insulated), the filter must be deactivated (by removing the two EMC jumpers).



For detailed information on how to remove the EMC jumpers, please refer to → section 3.3.4, "EMC jumper", page 46.

2.2.2 Mains voltage and frequency

The DE1... variable speed starter's wide tolerance range makes it possible to use the device with European ($U_{LN} = 230\text{ V}/400\text{ V}$, 50 Hz) and American ($U_{LN} = 240\text{ V}/480\text{ V}$, 60 Hz) standard voltages:

- 230 V, 50 Hz; 240 V, 60 Hz at DE1...-12...
200 V - 10 % - 240 V + 10 %
- 220 V, 60 Hz; 230 V, 60 Hz at DE1...-12...**N01**
200 V - 10 % - 240 V + 10 %
- 400 V, 50 Hz; 480 V, 60 Hz at DE1...-34...
380 V - 10 % - 480 V + 10 %
- 380 V, 60 Hz; 400 V, 60 Hz at DE1...-34...**N01**
380 V - 10 % - 480 V + 10 %

The permissible frequency range for all voltage categories is 50/60 Hz (48 Hz - 0% - 62 Hz + 0%).

When using variable speed starters that work with a three-phase power supply (DE1...-34...), the mains voltage unbalance (phase-phase) must be smaller than 3%. If this condition is not met, or if the unbalance at the point of connection is unknown, it is recommended to use a mains choke with the appropriate rating (see → section 9.7, "DX-LN... mains chokes", page 142) and a u_k value $\leq 4\%$.



Voltage unbalances greater than 3 % will cause the DE1 variable speed starter to shut down with a fault message.
(The **Fault Code** LED will flash cyclically 9 times with a 2-second pause, → table 48, page 152.)

2.2.3 Total Harmonic Distortion (THD)

The THD value (THD = Total Harmonic Distortion) is defined in standard IEC/EN 61800-3 as the ratio of the rms value of all harmonic components to the rms value of the fundamental frequency.



When using DE1...-12... variable speed starters, which work with a single-phase power supply, THD levels can be reduced by about 30 % by placing a mains choke upstream of the device (→ section 9.7, "DX-LN... mains chokes", page 142).

DE1...-34... variable speed starters, which work with a three-phase power supply, are designed as low harmonic drives. This means that it is not necessary to use a mains choke in order to reduce THD levels.

2.2.4 Reactive power compensation



In the AC supply systems with non-choked reactive current compensation devices, current oscillations, antiresonances and undefinable circumstances can occur.

If you are designing systems in which variable speed starters will be connected to AC power supply systems with undefined conditions, make sure to incorporate mains chokes into your design, → section 9.7, "DX-LN... mains chokes", page 142.

2.3 Safety and switching

2.3.1 Disconnecting device



Install a manual disconnecting device between the mains connection and the DE1... variable speed starter. This disconnecting device must be designed in such a way that it can be interlocked in its open position for installation and maintenance work.

In the European Union, this disconnecting device must be one of the following devices in order to comply with European Directives as per standard EN 60204-1, "Safety of machinery":

- An AC-23B utilization category disconnecter (EN 60947-3)
- A disconnecter with an auxiliary contact that in all cases will disconnect the load circuit before the disconnecter's main contacts open (EN 60947-3)
- A circuit-breaker designed to disconnect the circuit as per EN 60947-2

In all other regions, the applicable national and local safety regulations must be complied with.

2.3.2 Fuses and cable cross-sections

The DE1... variable speed starter and the corresponding supply cables must be protected from thermal overload and short-circuits.



The fuse ratings and cable cross-sectional areas (wire gauges) for the connection on the mains side will depend on the DE1... variable speed starter's input current I_{LN} .

The recommended ratings and sizes are listed in → section 9.5, "Cable and safety devices".

The mains cables and motor cables must be sized as required by local standards and by the load currents that will be involved. The rated operational currents are specified in → section 8.3, "Rating data", page 119.

The PE conductor's cross-sectional area must be the same as the phase conductors' cross-sectional area. The connection terminals marked with ⊕ must be connected to the earth-current circuit.

NOTICE

The specified minimum PE conductor cross-sections (EN 61800-5-1) must be maintained.

If there are leakage currents greater than 3.5 mA, a reinforced earthing (PE) must be connected, as required by standard EN 61800-5-1. The cable cross-section must be at least 10 mm², or the earthing system must consist of two separately connected earthing cables; → section 8.3, “Rating data”, page 119 provides the leakage currents for the individual models.

→ section 3.3.5, “Motor connection”, page 48 goes over the EMC requirements for the motor cables. A symmetrical, fully screened (360°), low-impedance motor cable must be used. The motor cable’s length will depend on the EMC category and the environment.

For US installations, UL-listed fuses, fuse bases, and cables (AWG) should be used exclusively. These cables must have a temperature rating of 75 °C (167 °F), and will often require installation inside a metal conduit (please consult the applicable local standards).

2.3.3 Residual current circuit-breaker (RCD)

When using DE1...-34... variable speed starters that work with a three-phase power supply, make sure to use type B AC/DC-sensitive residual current devices (RCD) exclusively. When using DE1...-12... variable speed starters that work with a single-phase power supply (L, N), you may use type A and type B residual current devices (RCD).

NOTICE

Residual current circuit-breakers (RCD = residual current device as defined in IEC/EN 61800-5-1, IEC 755) should only be installed between the power feed system (the AC supply system supplying power) and the DE1... variable speed starter – not at the output to the motor!

The contact and leakage currents’ magnitude will generally depend on:

- length of the motor cable,
- shielding of the motor cable,
- height of the pulse frequency (switching frequency of the inverter),
- design of the radio interference suppression filter,
- grounding measures at the site of the motor.

Other protective measures against direct and indirect contact can be used for DE1... variable speed starters, including isolating them from the supply system with the use of a transformer.



Due to the design used for single-phase devices, a higher leakage current will be produced if L1 and N are swapped.

2.3.4 Mains contactors

Using a mains contactor makes it possible to switch the variable speed starter's supply voltage on and off under normal operating conditions and to disconnect it in the event of a fault. This mains contactor needs to be sized based on the following: the DE1... variable speed starter's input current I_{LN} on the mains side, utilization category AC-1 (IEC 60947), and the ambient air temperature at the location of use. → section 9.6, "DIL...mains contactors", page 141, in the appendix, lists the mains contactor ratings that should be used for the various DE1... variable speed starters.



When designing your system, keep in mind that inching with the mains contactor is not permissible. The maximum permissible switching frequency for the mains voltage when running a DE1... variable speed starter is once every 30 seconds (normal operation).

2.3.5 Using a bypass connection



WARNING

Never connect the DE1... variable speed starter's output terminals U, V, and W to the power feed system (L1, L2, L3)! Connecting the mains voltage to the output terminals can result in the variable speed starter being irreparably damaged.

If a bypass is required, use mechanically joined switches or contactors in order to ensure that the motor terminals will not be simultaneously connected to the mains connection and to the variable speed starter's output terminals.

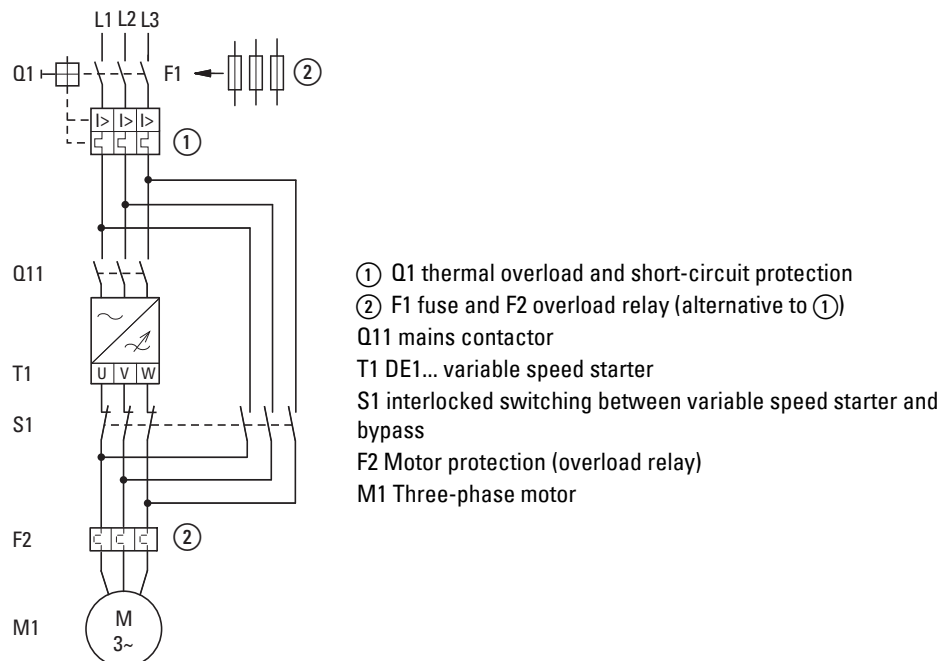


Figure 16: Bypass motor control (example)

2.4 EMC measures

When designing drives systems with variable speed (PDS), the necessary electromagnetic compatibility (EMC) measures should already be taken into account during the planning and configuration stage, as making changes during assembly and installation (or afterwards) at the installation location will likely result in additional, and significantly higher, costs.

Due to the characteristics of the technology and systems involved, high-frequency leakage currents will flow in a frequency controlled drive system during operation. Because of this, all earthing elements must be low-impedance elements connected in such a way as to establish an electrical contact across a large surface area.

The following is required in order to ensure that DE1... variable speed starters are installed in a manner that meets EMC requirements:

- Install the variable speed starter(s) in a conductive metal enclosure with a good connection to earth potential
- Screened cables with the shortest possible length



When working with frequency controlled drive systems, connect all conductive components, as well as the enclosure, to earth using a cable that is as short as possible and that has the largest possible cross-sectional area (copper lacing).

Inside the control panel, all of the device's metal parts should be connected to each other and to the control panel across a large area and in a manner suitable for high frequencies. Mounting plates and control panel doors should be connected to the panel by means of short drain wires with an electrical contact established across a large surface area. Do not make connections to painted surfaces (Eloxal, yellow chromated).



Mount the DE1... variable speed starter as directly as possible (without spacers) on a metal plate (mounting plate).



Route mains and motor cables in the control panel as close to the ground potential as possible. This is because free moving cables act as antennas.



If routed in parallel, cables carrying high frequencies (e.g., screened motor cables) and clean cables (e.g., mains supply cable, control and signal cables) should be installed at a distance of at least 300 mm from each other in order to avoid electromagnetic interference.

You should also route cables separately from each other if there are large differences in voltage. If control cables and power cables need to cross, they should always do so at a right angle (90°).

2 Engineering

2.4 EMC measures

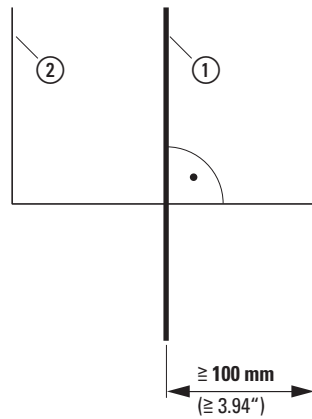


Figure 17: Cable routing



Do not route the control and signal cables ② in the same conduit as the power cables ①.
Analog signal cables (measured values, setpoints, and correction values) must be routed inside screened conduit.

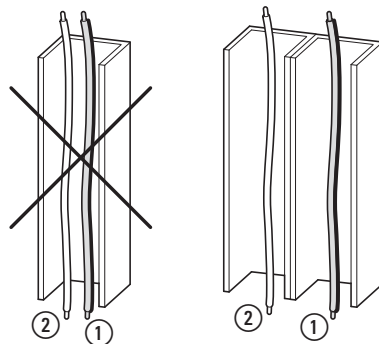


Figure 18: Separate routing

- ① Power cable: mains voltage, motor connection
- ② Control and signal lines, fieldbus connections

2.5 Motor Selection



Check whether your DE1... variable speed starter and the three-phase AC motor you will be using are compatible with each other as per the rating data table in → section 8.3, "Rating data", page 119.

2.5.1 Parallel connection of motors

DE1... variable speed starters can be used to run several motors in parallel.



If several motors are being connected, the total of their motor currents must be lower than the DE1... variable frequency starter's rated operational current.

Connecting several motors in parallel will reduce the resistance at the variable speed starter's output. The total stator inductance will be reduced and the cables' stray capacitance will be increased. The result will be greater harmonic distortion when compared to a single-motor connection.

A motor choke should be used at the variable speed starter's output in order to reduce this harmonic distortion.



When running several motors in parallel, it will not be possible to use the variable speed starter's electronic motor protection. As a result, each individual motor must be protected with thermistors and/or an overload relay.



Within a frequency range of 20 to 120 Hz, a PKE electronic motor-protective circuit-breaker can be used at the variable speed starter's output for motor protection purposes as well.

2.5.2 Circuit types with three-phase motors

The three-phase motor's stator winding can be connected in a star or delta circuit as per the rated operational data on the rating plate.

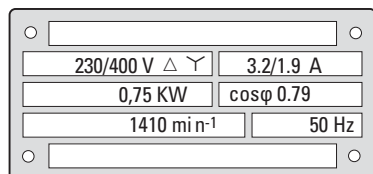


Figure 19: Example of a motor rating plate

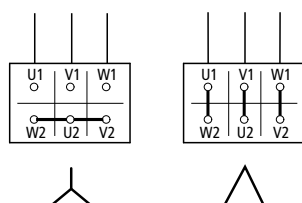


Figure 20: Configuration types:
Star-connected circuit (left), Delta circuit (right)

Examples based on figures 19 and 20

DE1-124D3... or DE11-124D3... ($U_{LN} = 230 \text{ V}$): Motor in delta circuit

DE1-342D1... or DE11-342D1... ($U_{LN} = 400 \text{ V}$): Motor in star connection

2.5.3 Connecting EX motors

The following aspects must be taken into account when connecting explosion-proof motors:

- A DE1... variable speed starter can be installed inside an explosion-proof enclosure within the hazardous location or inside a control panel outside the hazardous location.
- All applicable industry-specific and country-specific regulations for hazardous locations (ATEX 100a) must be complied with.
- The specifications and instructions provided by the motor's manufacturer with regard to operation with a variable speed starter – e.g., whether motor reactors (dV/dt limiting) are required – must be taken into account.
- Temperature monitors in the motor windings (thermistor, thermo-Click) are not to be connected directly to DE1... variable speed starters but must be connected via an approved trigger apparatus for EX areas i.e. EMT6.

3 Installation

3.1 Introduction

This chapter provides a description of the mounting and the electrical connection for the variable speed starter DE1...

- ➔ While installing and/or mounting the DE1... variable speed starter, cover all ventilation slots in order to ensure that no foreign bodies can enter the device.
- ➔ Perform all installation work with the specified tools and without the use of excessive force.
- ➔ For additional information on how to install the DE1... variable speed starter, please consult instruction leaflet IL040005ZU.

3.2 Mounting

The installation instructions described in this section assume that the device is being installed in an enclosure that is suitable for devices and that has a degree of protection of IP20 as defined in EN 60529.

- The enclosures must be made of a material with high thermal conductivity.
- If a control panel with ventilation openings is used, these openings must be located below and above the DE1... variable speed starter in order to ensure proper air circulation. Air should be delivered from the bottom and conveyed outwards through the top.
- If the environment outside the control panel contains dirt particles (e.g., dust), a suitable particulate filter must be placed on the ventilation openings and forced ventilation must be used.
The filters must be maintained and cleaned if necessary.
- An appropriate enclosed control panel (without ventilation openings) must be used in environments containing large percentages or amounts of humidity, salt, or chemicals.

- ➔ Install the DE1... variable speed starter only on a nonflammable mounting base (e.g., on a metal plate).

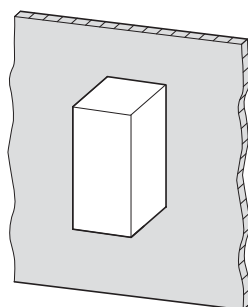


Figure 21: Surface mounting on metal plate

3 Installation
3.2 Mounting

3.2.1 Mounting position

DE1...-121D4..., DE1...-122D3... and DE1...-122D7... variable speed starters (devices without an internal fan) must be installed in a vertical position. The maximum permissible inclination for them is 5°. All other DE1... models can be installed with a maximum inclination of 90°.

Suspended mounting is not permissible!

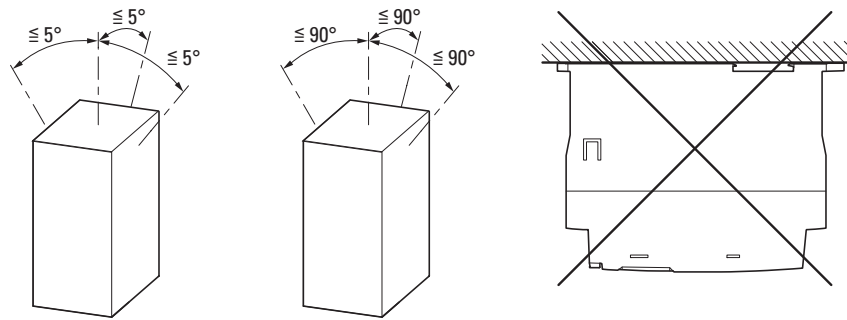


Figure 22: Mounting positions
(left: DE1...-121D4..., DE1...-122D3... and DE1...-122D7... devices)

3.2.2 Free space

In order to ensure that there will be adequate air circulation, large enough thermal clearances, as required by the specific DE1... variable speed starter, must be maintained.

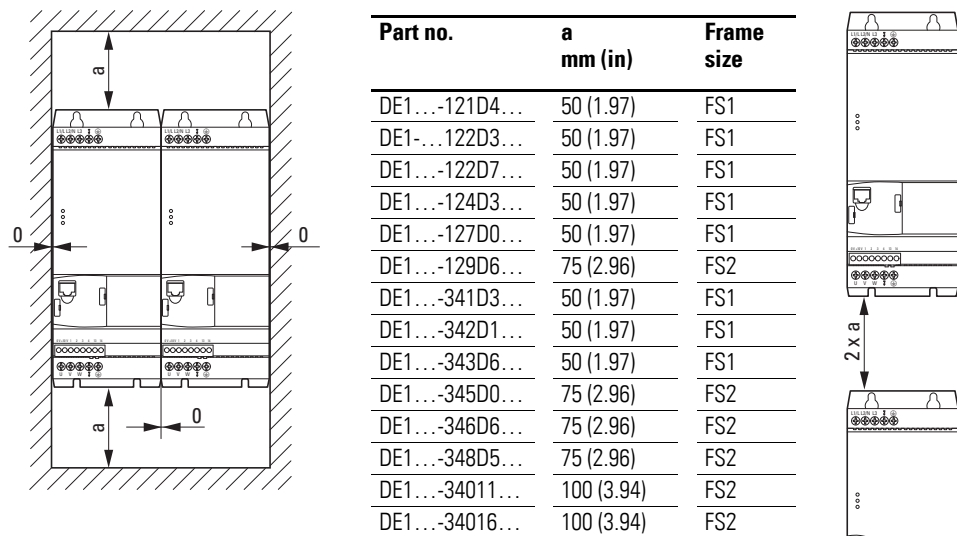


Figure 23: Space for air-cooling



DE1... variable speed starters can be installed next to each other without any clearance in between.

There must be a clearance of at least 15 mm in front of the device.



When using any of the following optional modules:

- DX-NET-SWD3 (SmartWire-DT)
- DXE-EXT-SET (configuration module)
- DX-KEY-LED2 (external keypad)

make sure to take into account the additional clearance that will be required in front of the DE1... variable speed starter.

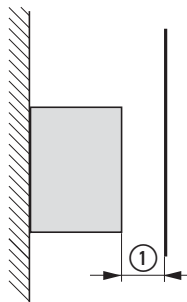


Figure 24: Minimum clearance



The appendix lists the dimensions, weights, and required mounting dimensions for the individual sizes (FS1, FS2).

3 Installation

3.2 Mounting

3.2.3 Fixing

All DE1... variable speed starter sizes can be mounted:

- with screws,
- on a mounting rail,

3.2.3.1 Fixing with screws



The appendix lists the dimensions, weights, and required mounting dimensions for the individual sizes (FS1, FS2).



Use screws with a washer and split washer with the permissible tightening torque of 1 Nm in order to protect the enclosure while safely and reliably mounting the device.

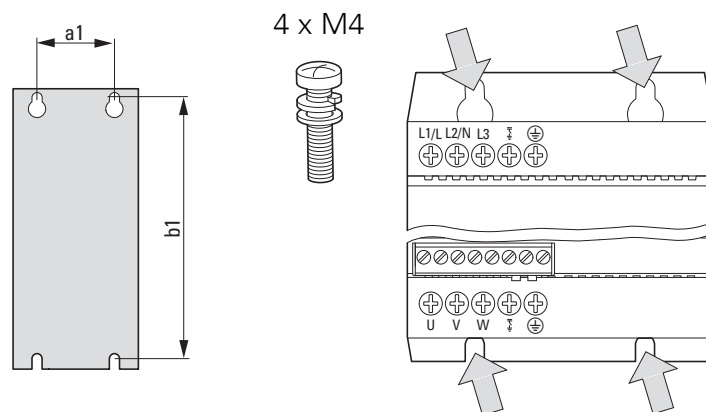


Figure 25: Screw fixing

3.2.3.2 Fixing on a mounting rail

As an alternative to screw fixing, DE1... variable speed starters can also be mounted on an IEC/EN 60715-compliant mounting rail.

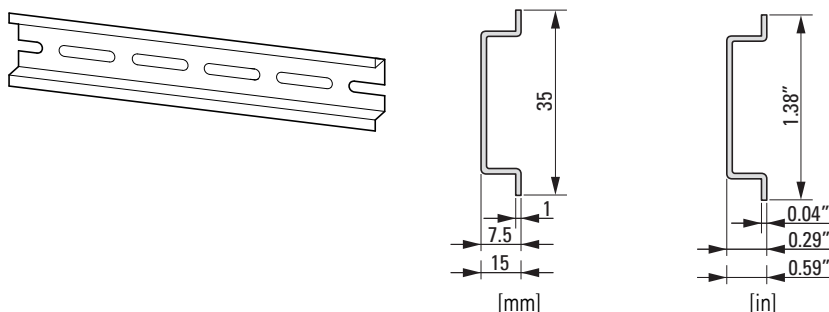


Figure 26: Mounting rail conforming with IEC/EN 60715

- ▶ To do so, place the DE1... variable speed starter on the mounting rail from above and then push it downwards [1]. After this, swing it onto the mounting rail [2] until it locks into place there [3].

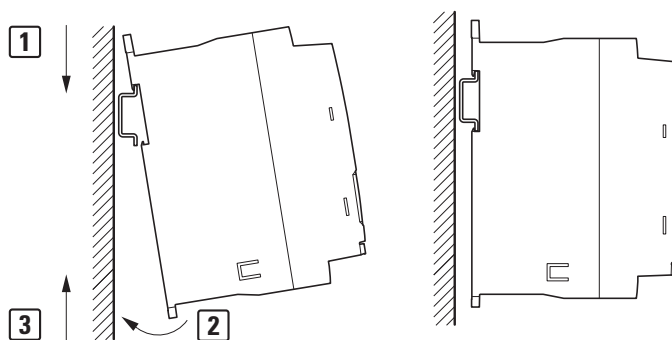


Figure 27: Fixing on a mounting rail

Dismantling from a mounting rail

- ▶ To remove the variable speed starter, first push it downwards [1]. Then grab the DE1... variable speed starter from the bottom edge and pull it forward [2]. Finally, lift it up and away from the mounting rail [3].

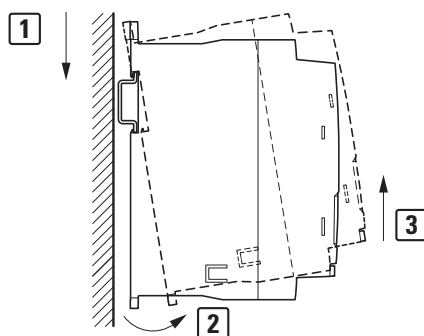


Figure 28: Dismantling from mounting rails

3 Installation

3.3 Electrical Installation

3.3 Electrical Installation



CAUTION

Carry out wiring work only after the variable speed starter has been correctly mounted and secured.



DANGER

Electric shock hazard - risk of injuries!
Before carrying out any wiring work (qualified personnel only), make sure that the system is fully de-energized.
Make sure to follow the safety rules on pages I and II.

NOTICE

Fire hazard!
Only use cables, circuit-breakers, and contactors that feature the indicated permissible nominal current value.



DANGER

The components in the variable speed starter's power section will remain energized for up to 5 minutes after the supply voltage is switched off (due to the DC link capacitors' discharge time).

Pay attention to hazard warnings!



Perform the steps below with the specified insulated tools and without using force.

3.3.1 Insulation test

The variable speed starters of the DE1... series are tested, delivered and require no additional testing.

If insulation testing is required in the power circuit of the PDS, you must consider the following measures.



Conduct the required insulation tests before connecting the cables to the DE1... variable speed starter.



CAUTION

Do not run any insulation resistance tests on the DE1... variable speed starter's control and connection terminals with an insulation tester.

Testing the mains cable insulation

- ▶ The mains cable must be disconnected from the power supply network and from the DE1... variable speed starter's L1/L, L2/N, and L3 connection terminals.
Measure the mains cable's insulation resistance between the individual phase conductors and between each phase conductor and the protective conductor.

The insulation resistance must be greater than 1 MΩ.

Testing the motor cable insulation

- ▶ The motor cable must be disconnected from the DE1... variable speed starter's U, V, and W connection terminals and from the motor (U, V, W).
Measure the motor cable's insulation resistance between the individual phase conductors and between each phase conductor and the protective conductor.

The insulation resistance must be greater than 1 MΩ.

Testing the motor insulation

- ▶ The motor cable must be disconnected from the motor (U, V, W).
Open the jumpers (star or delta) inside the motor terminal box.
Measure the individual motor windings' insulation resistance.

The insulation resistance must be greater than 1 MΩ.



Please refer to the motor manufacturer's manual for the exact insulation resistance values and permissible test voltages.

3 Installation

3.3 Electrical Installation

3.3.2 Connection to power section

The mains-side connection to the power section must be established using the connection terminals:

- L1/L, L2/N, PE for the single-phase supply voltage powering DE1-12... devices
- L1/L, L2/N, L3, PE for the three-phase supply voltage powering DE1-34... devices. The phase sequence does not matter.

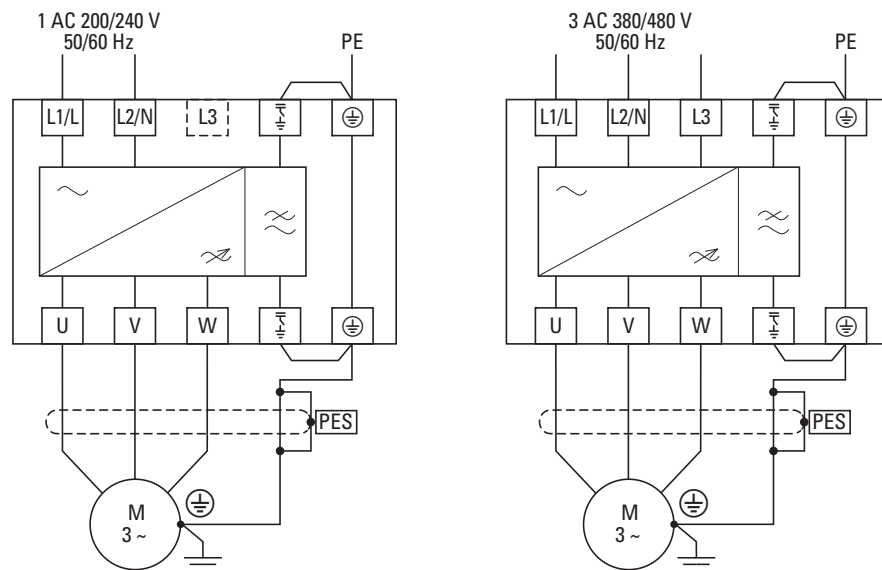


Figure 29: Connection on mains side (schematic)

The connection on the motor side must always be established using connection terminals U, V, and W.

NOTICE

The DE1... variable speed starter must always be connected with ground potential via a grounding conductor (PE).

NOTICE

Do not use any of the sealed-off connection terminals in the power section.

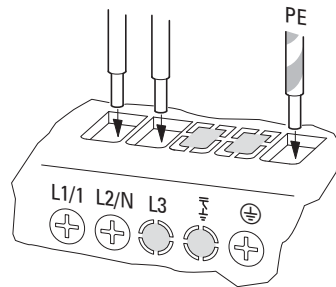


Figure 30: Sealed-off connection terminals (example: DE1-12...NN-...)

The connection terminals sealed off in Figure 30 (L3 and $\overline{\text{PE}}$) do not serve any function.



If you remove the EMC jumper from a DE1...-FN-... variable speed starter in order to use it under normal operating conditions (e.g., in an IT network), we recommend covering the open power terminals that are not being used (with electrical tape, for example) in order to prevent annoyances later on.

3.3.2.1 Power terminal designations

Table 4: Power terminal designations

Designation	Function	Notes
L1/L	Mains connection: <ul style="list-style-type: none"> Phase L1 in DE1...-34... devices Phase L in DE1...-12... devices 	Mains nominal voltages: DE1...-34...: 380 V/480 V (phase-phase) DE1...-12...: 200 V/240 V (phase-neutral conductor)
L2/N	Mains connection: <ul style="list-style-type: none"> Phase L2 in DE1...-34... devices N neutral conductor in DE1...-12... devices 	Mains nominal voltages: DE1...-34...: 400 V/480 V (phase-phase) DE1...-12...: 230 V/240 V (neutral conductor-phase)
L3	Mains connection: <ul style="list-style-type: none"> Phase L3 in DE1...-34... devices 	Mains nominal voltages: DE1...-34...: 400 V/480 V (phase-phase)
$\overline{\text{PE}}$	Ground connection (PE) for the internal RFI filter	Only for devices with an internal radio interference suppression filter (DE1...-FN-...). Link to PE terminal used only in combination with the EMC jumper on the motor side.
\oplus	PE, ground connection on mains side	Internal connection to the motor-side PE connection
U	Motor connection phase 1	Motor rated voltages: DE1...-34...: 400 V/460 V DE1...-12...: 230 V
V	Motor connection phase 2	
W	Motor connection phase 3	
$\overline{\text{PE}}$	Ground connection (PE) for the DC link's internal filter (star capacitor)	Only for devices with an internal radio interference suppression filter (DE1...-FN-...). Link to PE connection used only in combination with the EMC jumper on the mains side
\oplus	PE, ground connection on motor side	Internal connection to the mains-side PE connection

3 Installation

3.3 Electrical Installation

3.3.2 Connection examples

Table 5: Power section connection examples

	Connection terminals	Description
Mains connection		DE1...-12...FN-... with single-phase supply voltage (200 V/240 V) with built-in radio interference suppression filter
		DE1...-12...NN-... with single-phase supply voltage (200 V/240 V) without internal radio interference suppression filter
		DE1...-34...FN-... with three-phase supply voltage (380 V/480 V) with built-in radio interference suppression filter
		DE1...-34...NN-... with three-phase supply voltage (380 V/480 V) without internal radio interference suppression filter
Motor feeder		Three-phase motor connection for three-phase motors: <ul style="list-style-type: none"> • DE1...-12...FN-... (230 V) • DE1...-34...FN-... (400 V/460 V) with built-in radio interference suppression filter
		Three-phase motor connection for three-phase motors: <ul style="list-style-type: none"> • DE1...-12...NN-... (230 V) • DE1...-34...NN-... (400 V/460 V) without built-in radio interference suppression filter

3.3.2.3 Terminal capacities and stripping lengths

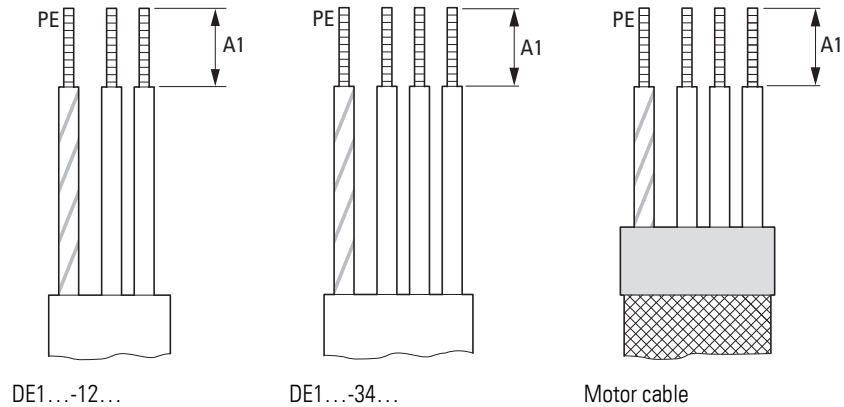


Figure 31: Stripping lengths in the power section

Table 6: Stripping lengths, conductor cross-sections, tightening torque

Stripping length A1		Clampable conductor cross-section		Maximum screw tightening torque	
mm	in	mm ²	AWG	Nm	lb-in
8	0.3	1 - 6	18 - 6	1.2	10.6

3.3.3 Earthing

Every DE1... variable speed starter must be individually connected to the power supply system's protective earth directly at the location of installation (system earthing). This protective earth must not pass through any other devices.

All protective earth conductors must be routed in a star-shaped layout extending from the central earth point, and all of the power drive system's conductive components (DE1... variable speed starter, mains choke, motor choke) must be connected.

The earth-fault loop impedance must comply with all locally applicable industrial safety regulations. In order to meet UL standards, UL-listed ring cable lugs must be used for all earth wiring connections.



Avoid ground loops when installing multiple variable speed starters in one control panel. Make sure that all metallic devices that are to be grounded have a broad area connection with the mounting plate.



In the case of variable speed starters with an internal interference radio interference suppression filter, the PE cable (DE1...-...FN-...) must be inserted behind the EMC jumper.

3 Installation

3.3 Electrical Installation

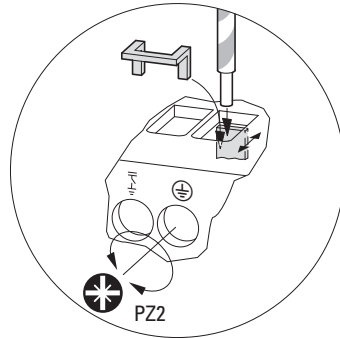


Figure 32: Inserting the PE cable behind the EMC jumper
(clamping action from the back towards the front)

3.3.4 EMC jumper

There are two DE1... variable speed starter versions:

- DE1...-...**FN**-...: **with** an internal radio interference suppression filter, **with** EMC jumpers,
- DE1...-...**NN**-...: **without** internal radio interference suppression filter, **without** EMC jumpers.

The EMC jumpers use the connection terminals to connect the filter on the mains side and the DC link filter (star capacitors) to the PE terminal on the mains and motor connection sides.

If you are planning to connect a DE1...FN-... variable speed starter to an IT (non-earthed) network or to a corner-earthed TN network, the internal EMC filters must be deactivated by removing the EMC jumpers. In the case of devices without an internal filter (DE1...-...NN-...), there will not be any EMC jumpers to begin with, and the filter connection terminals will not serve any function (they will be closed).

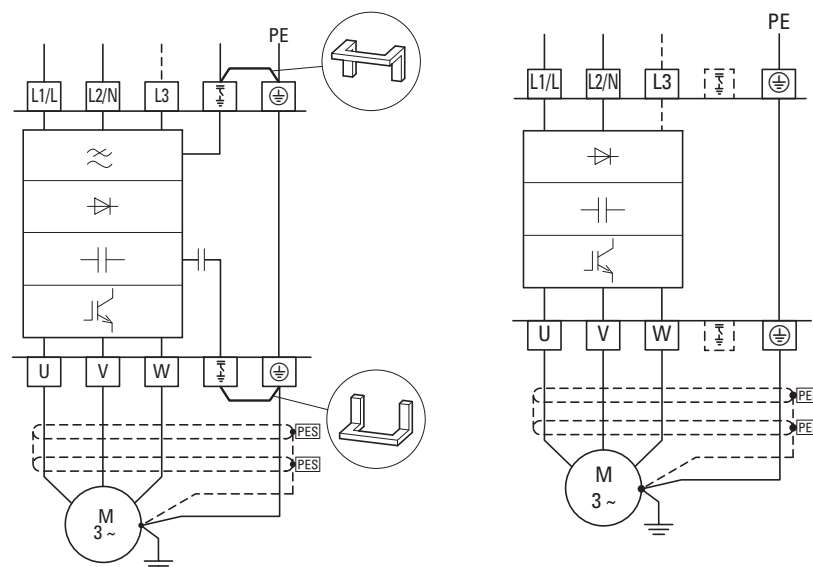


Figure 33: DE1...-...FN-... (**with** filter)

DE1...-...NN-... (**without** filter)

➔ If DX-EMV... external filters are used, the EMC jumper must be removed.

NOTICE

Do not insert or remove the EMC jumpers if the DE1... variable speed starter is connected to the electrical mains.

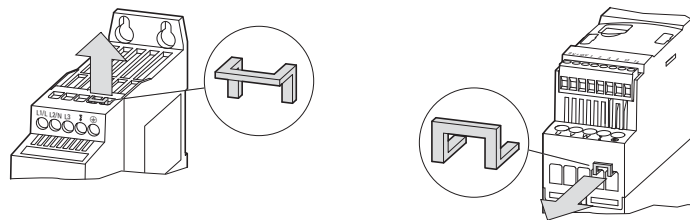


Figure 34: Removing the EMC jumpers on the mains and motor sides

➔ The two EMC jumpers must be removed!
Operating the device with only one EMC jumper is not permissible!

➔ If the EMC jumpers are removed, the filtering function required for electromagnetic compatibility (EMC) will no longer be active.

3 Installation

3.3 Electrical Installation

3.3.5 Motor connection

The connection between the DE1... variable speed starter and the motor should be as short as possible. The motor connection cable should be screened in order for the installation to meet EMC requirements.

- ▶ Connect the screening, on both sides and across a large area (360° overlap), to the protective earth (PE) \oplus . The power screening's protective earth (PES) connection should be in the immediate proximity of the DE1 variable speed starter and directly on the motor terminal box.

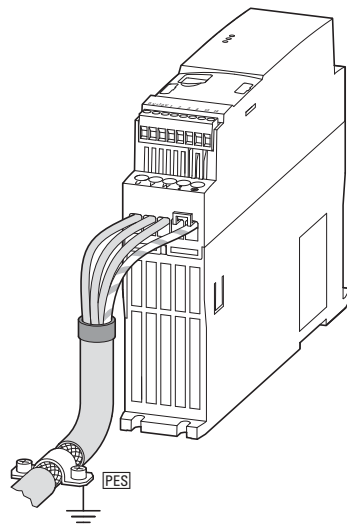


Figure 35: Motor side connection

- ▶ Prevent the screening from becoming unbraided, e.g. by pushing the opened plastic sheath over the end of the screening or with a rubber grommet on the end of the screening. Alternatively, in addition to the large-area gland plate, you can also twist the screen braid at the end and connect it to the protective earth. In order to prevent EMC interference, this twisted screen connection should be as short as possible (recommended value for the twisted cable screen: $b \geq 1/5 a$).

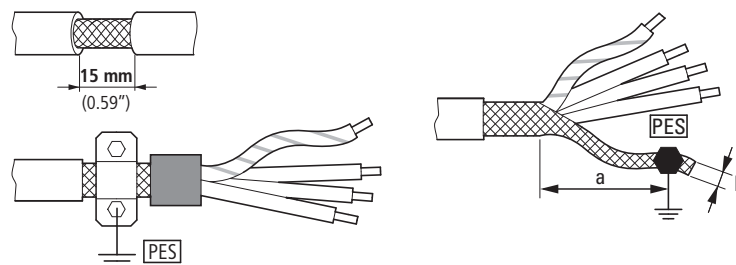


Figure 36: Screened connection cable in motor circuit

Screened, four-wire cable is recommended for the motor cables. The green-yellow line of this cable connects the protective ground connections from the motor and the variable speed starter and therefore minimizes the equalizing current loads on the shielding braid.

The following figure shows an example illustrating the layout for a four-core, screened motor cable (recommended configuration).

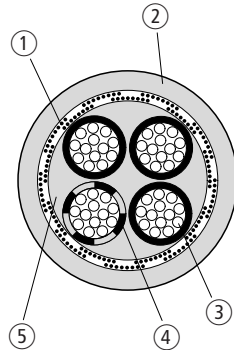


Figure 37: Four-core screened motor supply cable

- ① Cu shield braid
- ② PVC outer casing
- ③ Drain wire (copper strands)
- ④ PVC core insulation, 3 x black, 1 x green–yellow
- ⑤ Textile and PVC fillers

If additional assemblies (e.g., contactors, overload relays, motor chokes, and/or terminals) are found in a motor feeder, the motor cable's screening can be interrupted close to these assemblies and connected to the mounting plate (PES) in such a way that electrical contact is established across a large surface area. Unscreened connection cables should not be longer than approx. 300 mm.

3 Installation

3.3 Electrical Installation

3.3.6 Installations meeting UL® requirements

DE1... variable speed starters fully meet UL requirements, provided that the following conditions are fully met:

- In the case of DE1...-12... devices, the single-phase supply voltage must be connected to L1/L and L2/N. The maximum permissible rms voltage must not exceed 240 V RMS.
- In the case of DE1...-34... devices, the three-phase supply voltage must be connected to L1/L, L2/N, and L3. The phase sequence does not matter. The maximum permissible rms voltage must not exceed 500 V RMS.
- In order to meet CSA requirements, a TVSS is required on the DE1... variable speed starter's mains side. This suppressor must monitor the 600 V (phase to earth) and the 600 V (phase to phase), be suitable for overvoltage category III, and provide protection against and be able to withstand a rated surge voltage with 4 kV peaks or its equivalent.
- The maximum permissible short-circuit current (AC) in the input power supply must be 100 kA if fuses are used (600 V, UL class CC or class J). It must be 14 kA RMS if circuit-breakers are used (480 V, miniature circuit-breaker type B), as well as for DE1...-34... devices; 18 kA RMS if miniature circuit-breaker type E circuit-breakers are used.
- There must be a fixed installation with a suitable disconnecting device between the DE1... variable speed starter and the supply voltage as required by local safety codes and standards.
- Suitable copper wire mains and motor cables with a minimum insulation temperature rating of 75 °C (167 °F) must be used.
- The tightening torques for the power terminals, as defined in the specification for the individual models, must be used.
- Only one single conductor type is permissible for each power terminal. The PE conductor must be connected to metal enclosures using a ring cable lug.
- Motor overload protection options:
 - Overload relay, placed between the DE1... variable speed starter and the motor, that switches off the DE1... device in case of overload OR
 - Motor with thermistor that uses a thermistor overload relay (EMT6) to switch off the DE1... variable speed starter in case of overload OR
 - Motor with thermistor that switches off the DE1... variable speed starter directly with an external fault message (thermistor connected to control terminal 3 and +10 V), EXTFLT with mode 1 (P-15 = 1), mode 3 (P-15 = 3), mode 5 (P-15 = 5), mode 7 (P-15 = 7), and mode 9 (P-15 = 9). Prerequisite: P-19 = 0, OR
 - Motor thermal memory (P-33 = 0). Prerequisite: P-08 = Set to rated motor current.

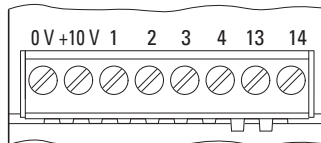


Instruction leaflet IL040005ZU includes a summary titled "Additional Information for UL® Approved Installations".

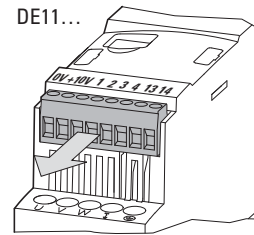
3.3.7 Connection to control section

The following connection terminals are used to make the connection to the control section:

- 0 V, +10 V: Control voltage output
- 1, 2, 3, 4: digital and analog inputs,
- Terminals 13, 14: for a potential-free relay output



DE1, DE11



DE11 only

Figure 38: Connection terminal layout on control section



ESD measures

Discharge yourself on a grounded surface before touching the control terminals and the circuit board to prevent damage through electrostatic discharge.

3.3.7.1 Terminal designation control section

Table 7: Terminal designation control section

Designation	Function	Notes
0 V	Ground GND	<ul style="list-style-type: none"> • For the internal control voltage (10 V) • For external control voltages (10 V/24 V) • For control inputs 1 - 4
+10 V	+10 VDC voltage output, max. 20 mA	Internal control voltage +10 V output for the DE1 device's digital and analog control inputs (terminals 1 to 4)
1	DI1, digital input 1	<ul style="list-style-type: none"> • Level for high signal: +9 - 30 V • Input current: 1.15/3 mA (10/24 V) • Default setting: FWD (enable signal for clockwise rotating field) • parameterizable
2	DI2, digital input 2	<ul style="list-style-type: none"> • Level for high signal: +9 - 30 V • Input current: 1.15/3 mA (10/24 V) • Default setting: REV (enable signal for counterclockwise rotating field) • parameterizable
3	DI3, Digital input 3	<ul style="list-style-type: none"> • Level for high signal: +9 - 30 V • Input current: 1.15/3 mA (10 V/24 V) • Default settings: FF1 (fixed frequency 20 Hz) • parameterizable
4	AI1, analog input 1	<ul style="list-style-type: none"> • Analog signal: 0 - +10 V • Input current: 0.12 mA • Resolution: 12 Bit • Default setting¹⁾ f-REF: 0 - f-max (50/60 Hz)
	DI4, digital input 4	<ul style="list-style-type: none"> • Level for high signal: +9 - 30 V • Input current: 1.15/3 mA (10/24 V) • parameterizable

3 Installation

3.3 Electrical Installation

Designation	Function	Notes
13	Relay contact ²⁾	<ul style="list-style-type: none"> • Potential-free relay contact (N/O), RUN • 230 V AC/30 V DC • Max. load current: 6 A (AC-1) / 5 A (DC-1)
14	Relay contact ²⁾	

1) Can be changed to a digital input with parameter P-15 (Table 22, page 95 and Table 33, page 107)

2) Parameterizable on DE11-... device Types

3.3.7.2 Connecting the control cables

The control cables are connected without screening. In the case of environments with extensive EM interference, as well as in the case of control cables connected outside the control panel (e.g., control panel with long connecting cable), it is recommended to connect a screened cable. In this case, the screening must be connected on one side, close to the DE1... variable speed starter (PES).

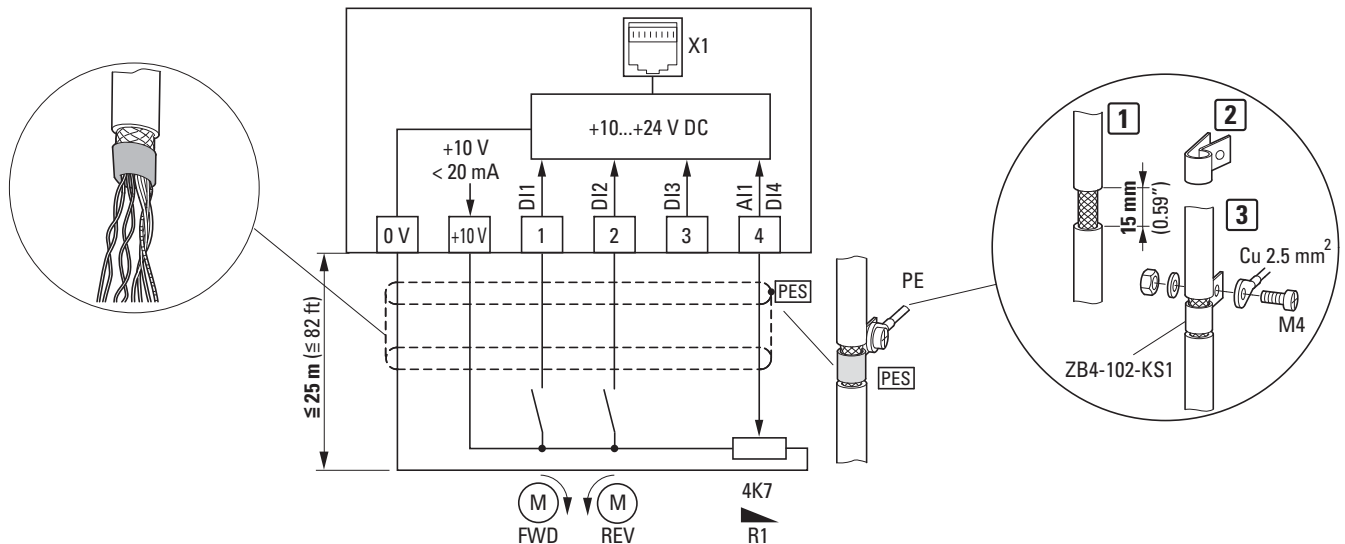


Figure 39: Control terminals connection example

The connecting example above (Figure 39) shows the one-sided PE connection (PES) between the control cable screening and a gland plate. The control cables should be twisted.




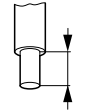




You can prevent the screening from fraying by sliding the cut plastic jacket over the screen's end or by placing a rubber grommet around it, for example.

3.3.7.3 Terminal capacities and stripping lengths

The terminal capacities and stripping lengths are listed in the following table.

Table 8: Connection cables at the control terminals

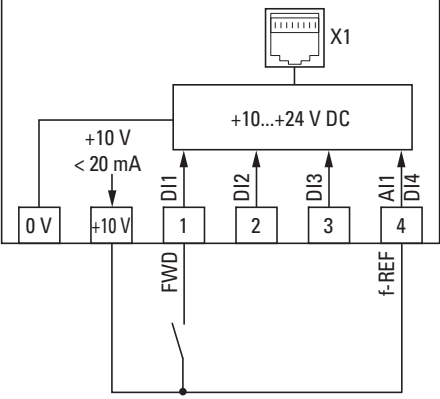
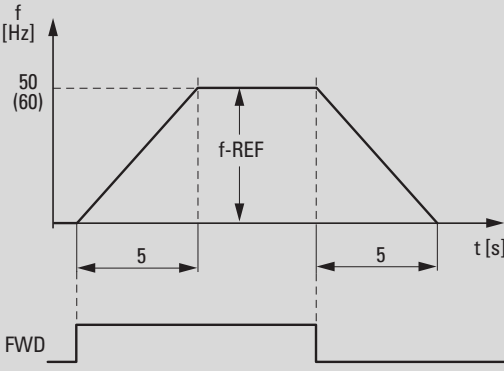
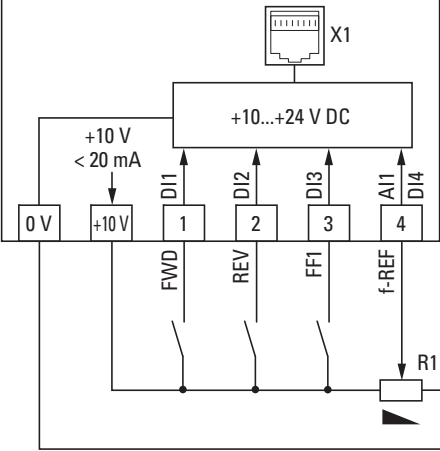
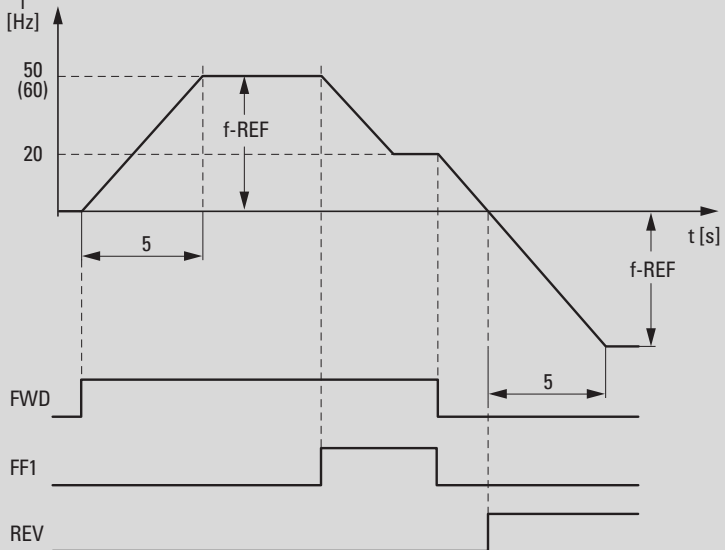
					
mm ²	mm ²	AWG	mm in	Nm lb-in	mm
0.5 - 1.5	0.5 - 1	30 - 16	5 0.2	0.5 6	0.7 x 3

3 Installation

3.3 Electrical Installation

3.3.7.4 Connection examples control section

Table 9: Connection examples with the mode 0 default setting (P-15)

Connection terminals	Description
	<p>Soft start function Motor start carried out with configured time parameters and preselected operating direction. DI1 = Clockwise rotation field enable (FWD) AI1/DI4 = Setpoint value (f-REF), +10 V = Maximum 50/60 Hz frequency (P-09) Acceleration ramp time: 5 seconds (P-03) If DI1 is switched off, the motor will be stopped in a controlled manner with a deceleration time of 5 seconds (P-04)</p> 
	<p>Variable speed starter (standard, default setting) Motor start in both operating directions with variable speed DI1 = Clockwise rotation field enable (FWD) DI2 = Anticlockwise rotation field enable (REV) DI3 = Fixed frequency (FF1 = 20 Hz); overwrites analog variable frequency reference value f-REF (0 - 10 V) AI1/DI4 = Setpoint value (f-REF), 0 - 10 V = 0 to 50/60 Hz max. frequency (P-09) Acceleration ramp time: 5 seconds (P-03) Deceleration ramp time: 5 seconds (P-04) R1: Reference value potentiometer (e.g., fixed value of 4.7 kΩ)</p> 



The connection terminals' function can be changed with:

- The DXE-EXT-SET configuration module's mode selector switch
- The parameters in the "drivesConnect" parameter configuration program
- The parameters accessed with the DX-KEY-LED2 external keypad

3.3.7.5 Analog input

Control terminal 4 (AI1/DI4) can be used either with analog or digital input signals.

If you are using the device's default settings, control terminal 4 will be configured as an analog input (AI1) for 0 - 10 V. The signal common will be control terminal 0 V.

To change the terminal's function, the value in parameter P-15 needs to be changed.

Parameter P-16 can be used to configure other analog input values:

- 0 - 10 V (default settings),
- 0 - 20 mA,
- 4 - 20 mA with open-circuit monitoring (fault message < 3 mA)
- 4 - 20 mA with open-circuit monitoring (< 3 mA: ramp-based change to fixed frequency FF1).

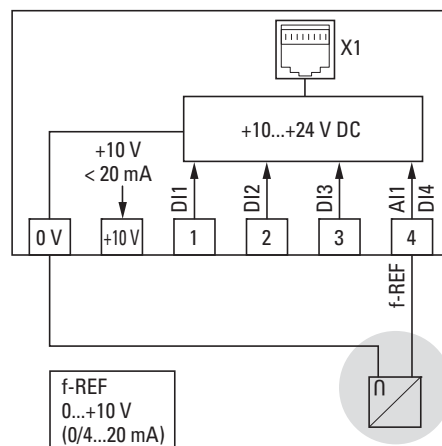


Figure 40: Connection example showing an external analog reference value source

Parameter P-17 can be used to scale the analog input values, while parameter P-18 can be used to invert them.



Table 35, page 110 goes over the parameters' configuration.

3.3.7.6 Digital inputs

As digital inputs (DI1, DI2, DI3), control terminals 1, 2, and 3 are identical in terms of their function and how they work. Control terminal 4 is set up as analog input AI1 in the device's default settings, but can instead be set up as digital input DI4 by using parameter P-15.

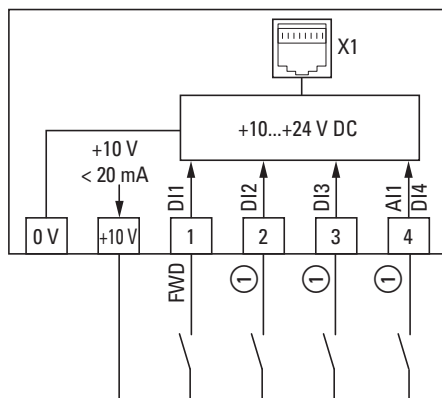


Figure 41: Connection example with four digital inputs

① The digital inputs can be configured with P-15 or with the DXE-EXT-SET configuration module (→ table 10)

Table 10: Digital input configuration using P-15

Mode	P-15	DI2	DI3	DI4
2	2	REV	FF2 ⁰	FF2 ¹
4	4	UP	FF1	DOWN
5	5	UP	EXTFLT	DOWN
6	6	REV	UP	DOWN
7	7	FF2 ⁰	EXTFLT	FF2 ¹

The digital inputs can be driven with the internal control voltage of +10 V (positive logic) from control terminal +10 V or with up to +24 V from an external voltage source:

- 9 - 30 V = High (logic "1")
- 0 - 4 V = Low (logic "0")

The signal common when using an external control voltage will be control terminal = 0 V.



If using an external voltage source, make sure that the external voltage source's 0-V potential and the DE1 variable speed starter's 0-V potential (0 V) are connected to each other. The external control voltage's residual ripple must be smaller than $\pm 5\% \Delta U_a / U_a$.

Table 11: Connection examples for the digital inputs (mode 0)

Connection terminals	Description
	<p>Default settings</p> <p>The digital inputs (DI1 - DI3) and the setpoint value (AI1) are driven with the internal +10 V control voltage through potentiometer R1 (0 - 10 V).</p>
	<p>External control voltage 24 V</p> <p>The digital inputs (DI1 - DI3) are driven with an external control voltage (+24 V).</p> <p>The setpoint value is set with the internal +10 V control voltage through potentiometer R1 (0 - 10 V).</p>
	<p>External control voltage through PLC</p> <p>The digital inputs (DI1 - DI3) are driven with an external control voltage (+24 V).</p> <p>The setpoint value is set with an external signal (0 - 10 V).</p> <p>Note: The signal common for the PLC's analog and digital outputs is 0 V.</p>

3 Installation

3.3 Electrical Installation

3.3.7.7 Relay contact (RUN)

Control terminals 13 and 14 are connected to the DE1... variable speed starter's internal potential-free relay contact (N/O).

- This contact will close when there is an enable signal (FWD, REV, ENA) and there are no fault messages present.
- The contact will open immediately when there is a fault message present.
- The contact will open if the enable signal is switched off (FWD, REV, ENA) and the motor coasts uncontrolled (P-05 default setting = 0).
- The contact will open after a delay, once the deceleration time set in P-04 elapses ($f_2 = 0$ Hz), if the enable signal (FWD, REV, ENA) is switched off.
- The contact will open after a delay if the enable signal (FWD, REV, ENA) is switched off and the motor is brought to a speed of 0 in line with the deceleration ramp (P-04 ramp time).

The supply data for control terminals 13 and 14 are:

- 250 V AC, max. 6 A AC1
- 30 V DC, max. 5 A DC1

In order to ensure smooth operation, we recommend adding suppressor circuits to inductive loads (e.g., coupling relays, contactors) as follows:

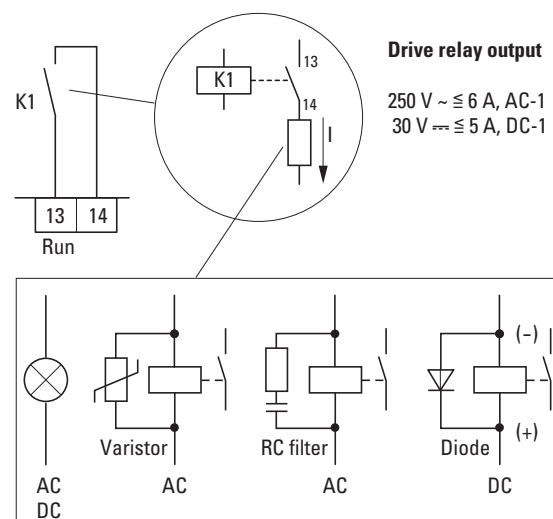


Figure 42: Connection examples with suppressor circuit

3.4 RJ 45 interface

The RJ45 interface in the front can be used to connect the device directly to communication and fieldbus connection modules (→ figure 44, page 60).

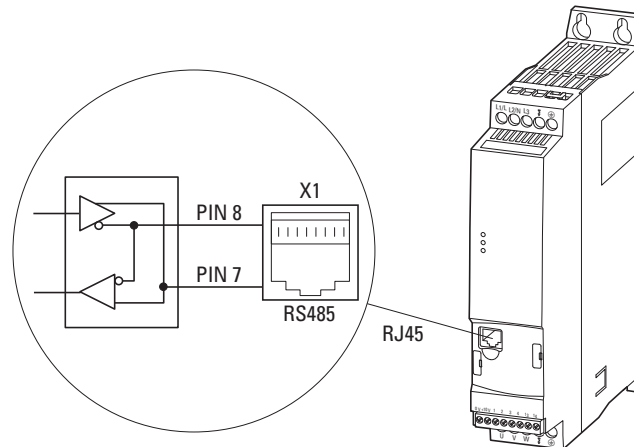


Figure 43: RJ 45 interface

The internal RS485 interface transmits Modbus RTU and for DE11... devices as well CANopen.

- ➔ DE1... variable speed starters do not have an internal bus termination resistor.
- ➔ If necessary, use the EASY-NT-R bus termination resistor.
CANopen: PIN 1 and PIN 2, 124 Ω
Modbus RTU: PIN 7 and PIN 8, 120 Ω
- ➔ For additional information on accessories, please refer to → chapter 9, "Accessory devices", page 131.
- ➔ The DXE-EXT-SET configuration module is described in detail in → chapter 5, "DXE-EXT-SET configuration module", page 71.

3 Installation

3.4 RJ 45 interface

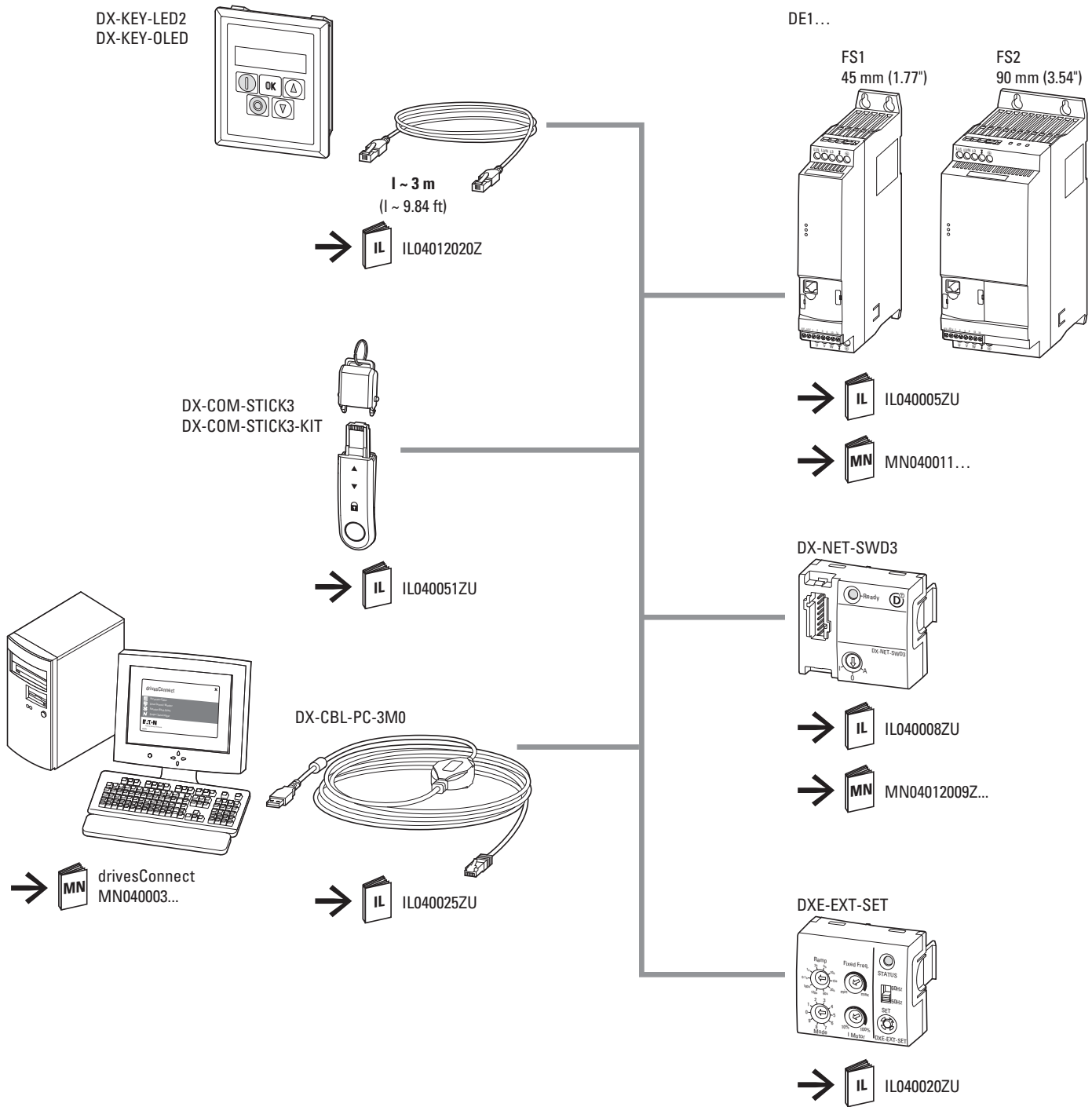


Figure 44: System overview for the DE1 variable speed starter's RJ45 interface

3.5 LED indicators

There are three light-emitting diodes (LEDs) used to show the DE1... variable speed starter's operating states.

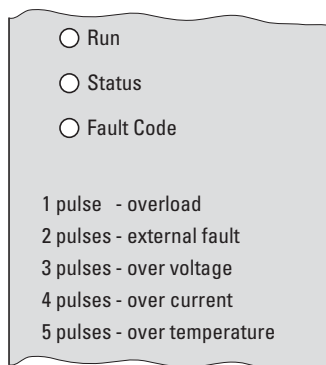


Figure 45: LEDs with fault codes (printed on housing)

The **Run**, **Status**, and **Fault Code** LEDs will behave as follows:

LED **Run**:

- operating signal.
- Flashes (with a green light) two times per second (with a frequency of 4 Hz) if there is a mains voltage present, there is no enable signal present at DI1 or DI2, and there are no active fault messages.
- Lights up with a continuous (green) light when the device is running (there is an active enable signal).
- Does not turn on if the switched-mode power supply (SMPS) is not working (e.g., mains undervoltage) or if there is an internal communication fault (the DE1... variable speed starter is malfunctioning).

LED **Status**:

- Status Message
- Flashes red with a frequency of 2 Hz and in combination with the **Fault Code** LED in the event of mains undervoltage.
- Lights up with a continuous red light in combination with the **Fault Code** LED if there is a fault (the DE1... variable speed starter is malfunctioning).

LED **Fault Code**:

- Used to signal faults
- Flashes red (cyclical flashing sequence with pauses) the appropriate number of times (1 time, 2 times, 3 times, ..., 13 times), followed by a 2-second pause (2 Hz + 2 s) (→ table 12).
- Flashes red with a frequency of 2 Hz and in combination with the **Status** LED in the event of mains undervoltage.
- Lights up with a continuous red light in combination with the **Status** LED in the event of an internal communication fault (DE1... malfunctioning).
- Lights up with a continuous yellow light if the DE1 variable speed starter's DC braking is active.

3 Installation

3.5 LED indicators

Table 12: "Fault Code" LED fault messages

Fault code	Flashing frequency: 2 Hz (followed by a 2-second pause)	Meaning
1 pulse - overload	1 x	Thermal motor overload
2 pulses - external fault	2 x	External fault message
3 pulses - over voltage	3 x	Overvoltage
4 pulses - over current	4 x	Overcurrent
5 pulses - over temperature	5 x	Overtemperature
	6 x	Fault in power section
	7 x	Communication fault
	8 x	Default parameter setting
	9 x	DC residual ripple
	10 x	Live zero error
	11 x	Under-temperature
	12 x	Thermistor fault
	13 x	Data error



For a detailed description of the fault messages, please refer to
 → chapter 10, "Fault messages", page 149.

3.6 Block diagrams

The following block diagrams show all of the DE1 variable speed starter’s connection terminals and their functions when the device is used with its default settings.

3.6.1 DE1...-12...FN-...

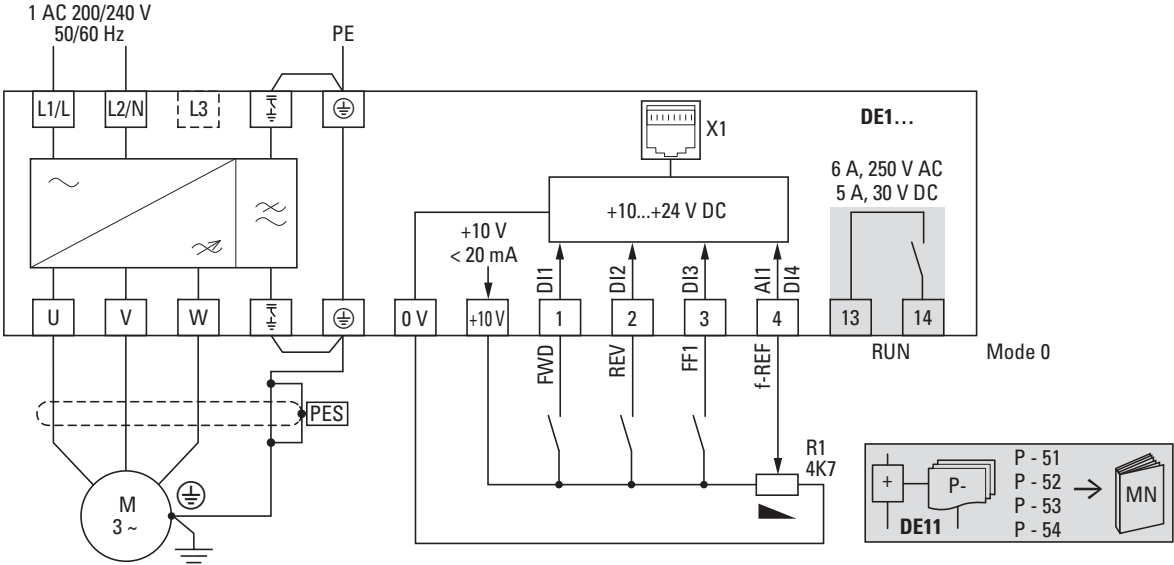


Figure 46: DE1-12...FN-... block diagram
 Variable speed starter with single-phase mains supply voltage and internal radio interference suppression filter

3.6.2 DE1...-12...NN-...

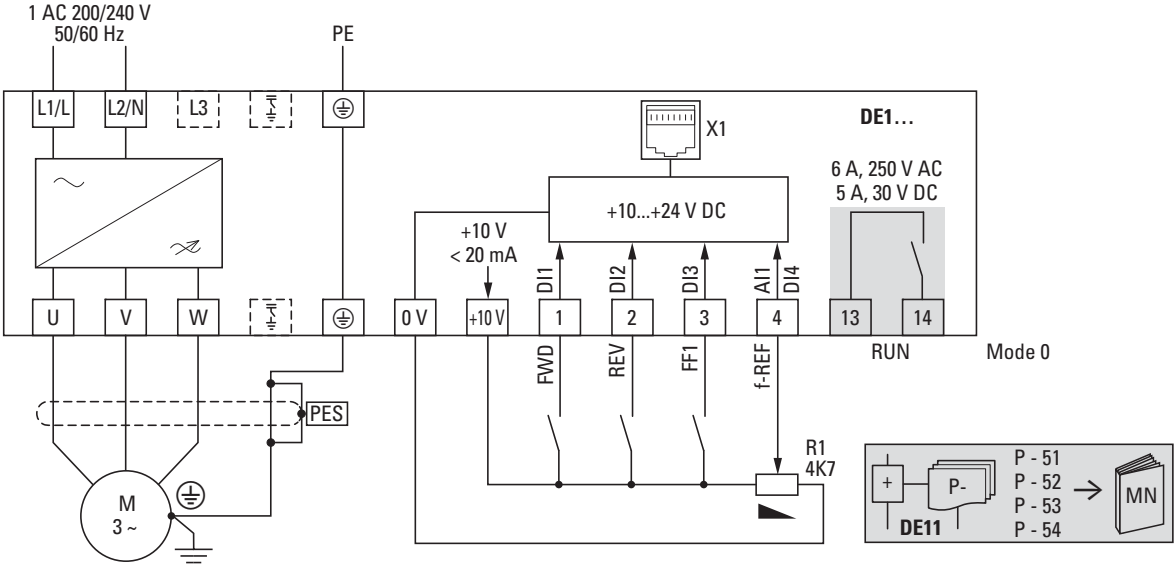


Figure 47: DE1-12...NN-... block diagram
 Variable speed starter with single-phase mains supply voltage
 No internal radio interference suppression filter

3 Installation

3.6 Block diagrams

3.6.3 DE1...-34...FN-...

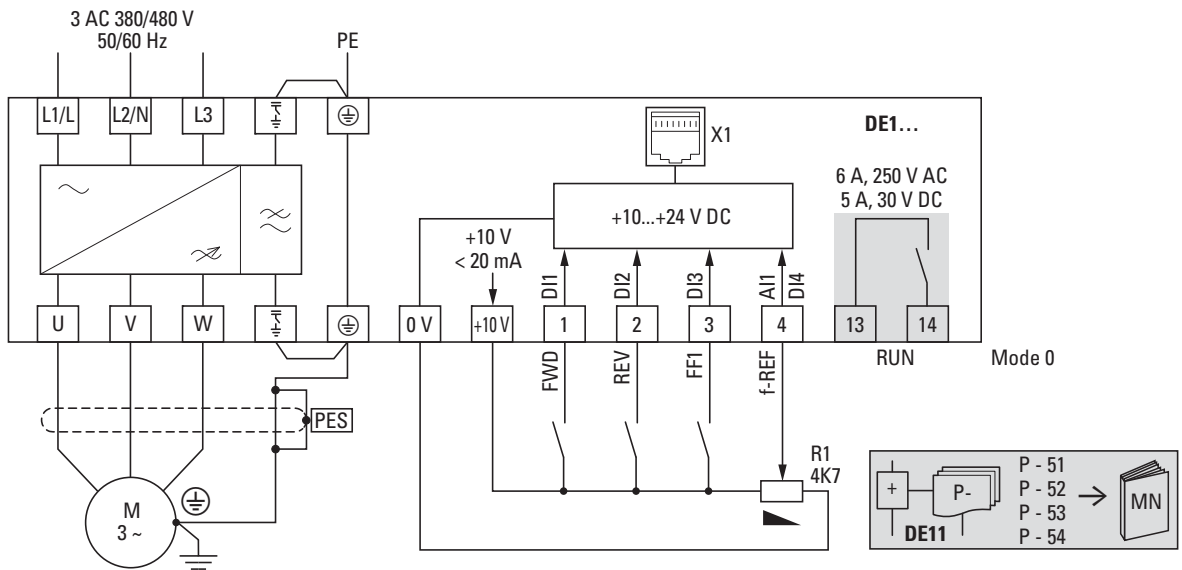


Figure 48: DE1-34...FN-... block diagram
Variable speed starter with three-phase mains supply voltage and internal radio interference suppression filter

3.6.4 DE1...-34...NN-...

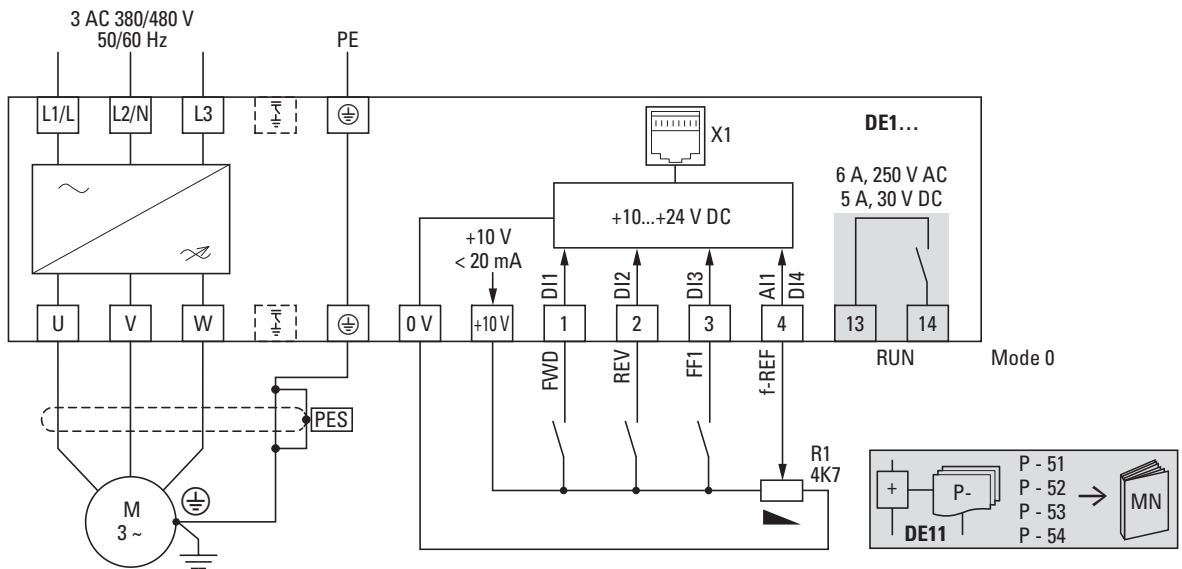


Figure 49: DE1-34...NN-... block diagram
Variable speed starter with three-phase mains supply voltage
No internal radio interference suppression filter

4 Operation

4.1 Checklist for commissioning

Before putting the variable speed starter into operation, make sure to check the following checklist items:

Table 13: Checklist for commissioning

No.	Activity	Space for writing down comments
1	The device has been installed and wired as specified in the instruction leaflet (→ IL040005ZU).	
2	All leftover wiring and cable segments, as well as all the tools that were used, have been removed from the vicinity of the variable speed starter, the motor, and all moving machine parts.	
3	All the connection terminals in the power section and in the control section have been tightened with the required torque.	
4	The cables connected to the variable speed starter's output terminals (U, V, W) are not being short-circuited and are not connected to earth (PE).	
5	The variable speed starter is properly earthed and connected to the PE. The connection terminals are labeled with an earth symbol.	
6	All the electrical connections in the power section have been sized and configured as required and are properly connected. DE1...-12... to L1/L, L2/N and PE DE1...-34... to L1/L, L2/N, L3 and PE Motor to U, V, W, and PE	
7	Every single supply voltage phase (L or L1, L2, L3) is being protected by a fuse or a circuit-breaker.	
8	The DE1... variable speed starter and the motor are configured for the mains voltage being supplied. DE1...-12...: 200 - 240 V ±10 % DE1...-34...: 380 - 480 V ±10 % Motor: configuration (star, delta)	
9	The cooling air's quality and volume will ensure that the required ambient conditions for the DE1... variable speed starter and the motor will be met.	
10	All connected control cables and switchgear will ensure that the required stop conditions will be met when necessary.	
11	The operating direction of a connected machine will make it possible for the motor to be started (→ Check the U, V, W phase sequence or the FWD or REV operating direction).	
12	All emergency switching off functions and safety functions are in an appropriate condition.	

4 Operation

4.2 Hazard warnings for operation

4.2 Hazard warnings for operation

Please observe the following notes.



DANGER

Commissioning is only to be completed by qualified technicians.



DANGER

Hazardous voltage!

The safety instructions on pages I and II must be followed.



DANGER

The components in the DE1 variable speed starter's power section will remain energized as long as the supply voltage (mains voltage) is connected. This includes, for example, power terminals L1/L, L2/N, L3, U, V, and W.

The control signal terminals are isolated from the line power potential.

There might be a dangerous voltage at the relay terminals (13, 14) even if the variable speed starter is not being powered with mains voltage (when the relay contacts are connected to PLCs with voltages > 48 VAC / 60 VDC, for example).



DANGER

The components in the DE1 variable speed starter's power section will remain energized for up to 5 minutes after the supply voltage is switched off (due to the DC link capacitors' discharge time).

Pay attention to hazard warnings!



DANGER

Following a shutdown (fault, mains voltage off), the motor can start automatically (when the supply voltage is switched back on) if the automatic restart function has been enabled (→ parameters P-31).

NOTICE

Inching operation using the mains contactor is not permitted.
Contactors and switchgear (repair and maintenance switches) on the motor side must not be opened while the motor is in operation.
Inching the motor with contactors and switchgear at the DE1... variable speed starter's output is not permissible.

NOTICE

Make sure that starting the motor will not put anyone or anything in danger. Disconnect the driven machine if there is a danger in an incorrect operating state.



If motors are to be operated with frequencies higher than the standard 50 or 60 Hz, then these operating ranges must be approved by the motor manufacturer. The motors could be damaged otherwise.

4 Operation

4.3 Protection against electric shock

4.3 Protection against electric shock

Ensuring protection against electric shock when using the DE1 variable speed starter... as per IEC/EN 61800-5-1

Manufacturer declaration for initial testing per IEC/HD 60364-6 (DIN VDE 0100-600 (VDE 0100-600)) and for periodic testing as per EN 50110-1 (DIN VDE 0105-100 (VDE 0105-100))

Error protection per IEC/HD 60364-4-41 (DIN VDE 0100-410 (VDE 0100-410)) for the circuit on the output side of the aforementioned equipment is ensured based on the following requirements:

The installation instructions in this documentation have been observed.

The applicable standards in the IEC/HD 60364 (DIN VDE 0100 (VDE 0100)) series have been observed.

The continuity of all associated protective conductors and equipotential bonding conductors, including the corresponding connection points, has been ensured.

Provided that the above requirements are met, the aforementioned equipment meets the requirements in IEC/HD 60364-4-41 (DIN VDE 0100-410 (VDE 0100-410): 2007-06, section 411.3.2.5) when the "automatic power supply shutdown" protective measure is applied.

The note is based on the following information:

In the event of a short-circuit with negligible impedance to a protective conductor or to ground, the aforementioned equipment reduces the output voltage within the times as per Table 41.1 or otherwise within 5 seconds – whichever applies – in accordance with IEC/HD 60364-41 (DIN VDE 0100-410; VDE 0100-410):2007-06).

4.4 Commissioning with default settings

Following is a simplified connection example for operating the device with its default settings:

Connection example	Terminal	Designation
	L1/L	Three-phase mains connection (DE1...-12...)
	L2/N	Three-phase mains connection (DE1...-34...)
	L3	–
	⊕	Ground connection (PE)
	⊖	Jumper from internal EMC filter to ground connection – only in DE1...-...FN-... devices
	0 V	Signal common (0 V)
	+10 V	internal control voltage +10 V (output max. 20 mA)
	1	FWD, Start release clockwise rotating field
	4	Frequency reference value (input f-REF 0 - +10 V) from potentiometer R1
	U	Connection for three-phase ac motor (three-phase motor)
	V	
	W	
	⊕	Ground connection (PE), motor cable screening (PES)
	⊖	Jumper from internal EMC filter to ground connection – only in DE1...-...FN-... devices

- ▶ For simple commissioning with the preset default settings, connect the DE1... variable speed starter as shown in the connection example above.

The reference value potentiometer should have a fixed resistor with a resistance of at least 1 kΩ min and at most 10 kΩ max (connect to control terminals +10 V and 0 V). A value of 4.7 kΩ is recommended.



If the reference value potentiometer's terminals cannot be clearly assigned to terminals 0 V, +10 V, and 4, set the potentiometer to about 50 % before activating a start enable signal (FWD) for the first time.



Make sure that the enable contact (FWD) is open before switching on the mains voltage.

When the required supply voltage is applied at the mains connection terminals (L1/L and L2/N in DE1...-12... devices; L1/L, L2/N, and L3 in DE1...-34... devices), the switched-mode power supply (SMPS) in the DC link will be used to generate the control voltage and the **Run** LED will flash with a green light. When this occurs, the DE1... will be ready for operation (normal operating state) and in Stop mode.

To activate the start enable signal, drive control terminal 1 with +10 V: The **Run** LED will light up with a continuous light.

Potentiometer R1 can be used to set the desired speed value for the motor.

4 Operation

4.4 Commissioning with default settings

5 DXE-EXT-SET configuration module

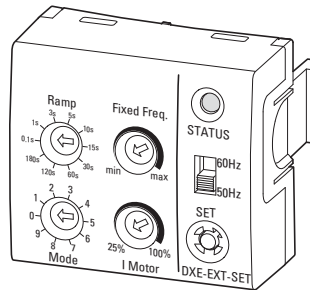


Figure 50: DXE-EXT-SET configuration module

The DXE-EXT-SET configuration module can be used to easily change the default settings for a DE1... variable speed starter without having to use a keypad or a computer. DXE-EXT-SET works like a mechanical parameter storage unit. For example, it can be used to transfer (copy) the values set with it (STATUS LED lit up with a green light) to other DE1... variable speed starters with the same output rating (SET pushbutton).



The DXE-EXT-SET configuration module is an optional accessory and is not included as standard with the DE1... variable speed starter.

5.1 DXE-EXT-SET designation

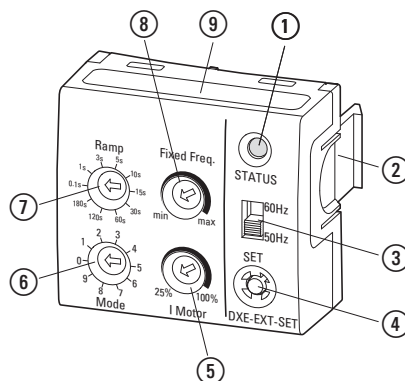


Figure 51: DXE-EXT-SET designation

- ① Status LED
- ② Mounting clips for DE1... variable speed starters
- ③ 50/60 Hz selector switch – used to automatically adjust the default settings as required for the mains frequency being used
- ④ **SET** pushbutton – used to transfer the modified settings to the DE1... variable speed starter
- ⑤ **I Motor** potentiometer – can be used to adjust the motor protection setting ($I \times t$ value)
- ⑥ **Mode** selector switch – used to configure the control terminals' functions
- ⑦ **Ramp** selector switch – used to change the ramp times (acceleration and deceleration)
- ⑧ **Fixed Freq.** potentiometer – used to adjust fixed frequency FF1 within the range defined by the minimum and maximum limits
- ⑨ Mode – overview of control terminal configurations

5 DXE-EXT-SET configuration module

5.2 Plugging the module into / removing it from a DE1... variable speed starter

5.2 Plugging the module into / removing it from a DE1... variable speed starter

The DXE-EXT-SET configuration module is designed to be plugged into the DE1... variable speed starter's RJ45 socket in such a way that the module's two mounting clips will go into the corresponding openings on the starter.



The DXE-EXT-SET configuration module can be connected and removed by hand – no tools are required. Make sure not to use excessive force when plugging in and removing the module or when adjusting its settings.



The DXE-EXT-SET configuration module can be plugged in and removed during operation (while the **Run** LED is on).

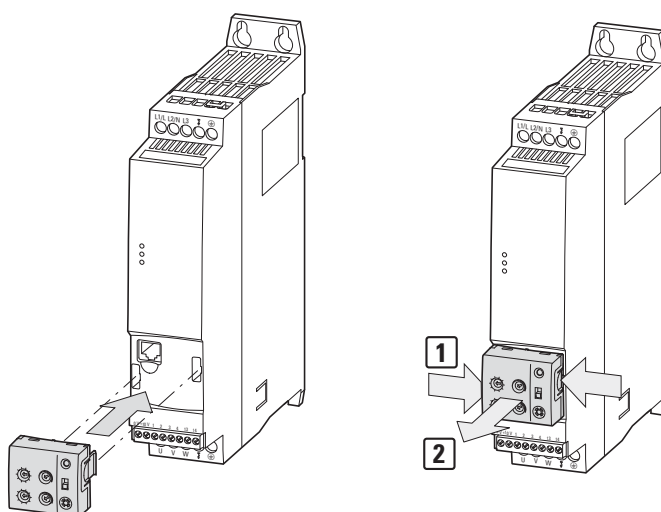


Figure 52: Plugging in and removing the module

Normally, the DXE-EXT-SET configuration module is not intended to remain plugged in during continuous operation. Generally speaking, its switch settings and other settings cannot be changed by accident, as changing them requires a tool and a transfer command (SET), and the command can only be activated in the STOP state.

However, it is important to point out that all mechanically adjustable values can be intentionally changed at any time as long as the configuration module is plugged in.

To remove the module, simply squeeze the two mounting clips [1]. Then pull the configuration module forward while continuing to press on the mounting clips [2].

5.3 Description and use

In order to be able to adjust the potentiometer and rotary switch settings on the DXE-EXT-SET configuration module, you will need a flat-blade screwdriver (0.4 x 2.5 mm).

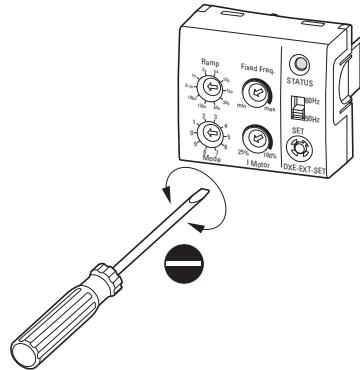


Figure 53: Screwdriver (0.4 x 2.5 mm)

The settings (parameters) can be mechanically adjusted regardless of whether the DXE-EXT-SET configuration module is plugged into a DE1... variable speed starter or not.

NOTICE

Changing drive-specific settings!

If an "undefined" DXE-EXT-SET is plugged into a DE1... variable speed starter that is already configured and the **STATUS** LED (on the DXE-EXT-SET) lights up with a yellow light, this means that the device's specific settings can be changed by pressing the SET button (while the starter is in STOP mode).

For example:

- The control terminals' configuration (mode = P-15)
- Current limitation (I Motor = P-08)
- Acceleration and deceleration times (Ramp = P-03 and P-04)
- Fixed frequency value (FF1 = P-20)
- All parameter values based on the basic frequency (50/60 Hz → P-01)



The DE1... variable speed starter's parameters can be write-protected (so that they cannot be overwritten) with the drivesConnect parameter configuration program or the DX-KEY-LED keypad by setting parameter P-39 to 1 (parameter lock).

Exception:


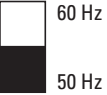

Even if the starter's parameters are locked, it will be possible to change the value of parameter P-20 (FF1) with the Fixed Freq. potentiometer on the DXE-EXT-SET configuration module.

5 DXE-EXT-SET configuration module

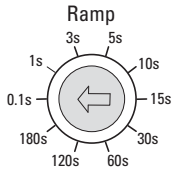
5.3 Description and use

The following table goes over the use and functions of the operator control and indication elements on the DXE-EXT-SET configuration module when it is plugged in and the DE1... variable speed starter is ready for operation (**Run** LED on).

Table 14: Functions of operator control and display elements on DXE-EXT-SET

Element	Behavior	Description
 STATUS	green	LED STATUS The settings on the configuration module are identical to the parameter values on the DE1... variable speed starter.
	yellow	The settings on the DXE-EXT-SET configuration module are not identical to the parameter values on the DE1... variable speed starter. Example: <ul style="list-style-type: none"> • The settings on the plugged-in configuration module have changed. • A configuration module with different settings has been plugged in
	Green – flashing slowly (three times for 2 s), then showing a continuous green light	The SET button has been pressed for about 2 seconds in STOP mode. All the settings in the DXE-EXT-SET module are being transferred to the DE1... variable speed starter's parameters. A green continuous light indicates that the data transfer has been completed successfully.
	fast flashing (4 Hz)	The SET button has been pressed briefly (< 1 s). The Fixed Freq. potentiometer is active and is directly overwriting the value in the DE1... variable speed starter's P-20 (FF1) parameter. Note: The drive's speed can be directly adjusted in RUN mode, provided there is an FF1 enable signal at the appropriate control terminal (see modes 0, 2, 3, 4, 7, 8 = P-15). If the SET button is pressed again, the current Fixed Freq. potentiometer value will be stored in P-20.
		50/60-Hz selector switch The mains frequency selector switch can be used to automatically make all the necessary changes to the calculations in the motor model and the characteristic curve parameters (e.g., max. frequency, V/HZ characteristic curve, speed control, etc.) used to operate motors with the corresponding standard frequencies (50/60 Hz).
 SET		SET button <ul style="list-style-type: none"> • If it is pressed for about 2 seconds in STOP mode, the SET button will start transferring all "mechanically" set values from the DXE-EXT-SET configuration module to the corresponding parameters in the DE1... device. During the transfer, the STATUS LED will flash three times for 2 seconds and will then show a continuous green light if the data transfer is successfully completed. • When in RUN mode, briefly pressing the SET button (< 1 second) will start directly transferring the Fixed Freq. potentiometer setting to the DE1... variable speed starter's P-20 (FF1) parameter. In order for this transfer to stop, the SET button needs to be pressed again. • In an operating mode with the FF1 control command active (modes 0, 2, 3, 4, 7, 8), the Fixed Freq. potentiometer can be used to directly adjust the drive's speed.

Element	Behavior	Description
---------	----------	-------------

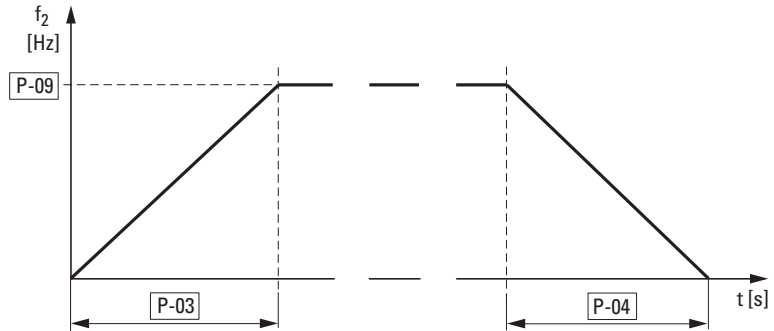


P-09 = Rated motor frequency

Ramp selector switch

0.1 s / 1 s / 3 s / 5 s / 10 s / 15 s / 30 s / 60 s / 120 s / 180 s

The 10-setting Ramp selector switch can be used to select a set acceleration time (P-03) and deceleration time (P-04). The selected ramp time must be activated with the SET button (pressed for 2 seconds) while in STOP mode (the STATUS LED will flash three times for 2 seconds and will then show a continuous green light).



Fixed Freq.



Fixed. Freq. potentiometer

The Fixed Freq. potentiometer can be used to adjust the frequency reference value between the f-min (P-02) and f-max (P-01) limits (the setting is infinitely variable). The potentiometer will become active after the SET button is pressed (< 1 second). The STATUS LED will flash with a frequency of 4 Hz when this happens.

When used this way, the Fixed Freq. potentiometer will directly overwrite the value in the DE1... variable speed starter's P-20 (FF1 fixed frequency) parameter.

Note:

The drive's speed can be adjusted directly in RUN mode when there is an FF1 enable signal at the appropriate control terminal (see modes 0, 2, 3, 4, 7, 8 = P-15). If the SET button is pressed again briefly, the frequency value currently being transferred will be stored in P-20.



Example:

Mains voltage:
 $U_{LN} = 400\text{ V} \rightarrow \text{P-07}$

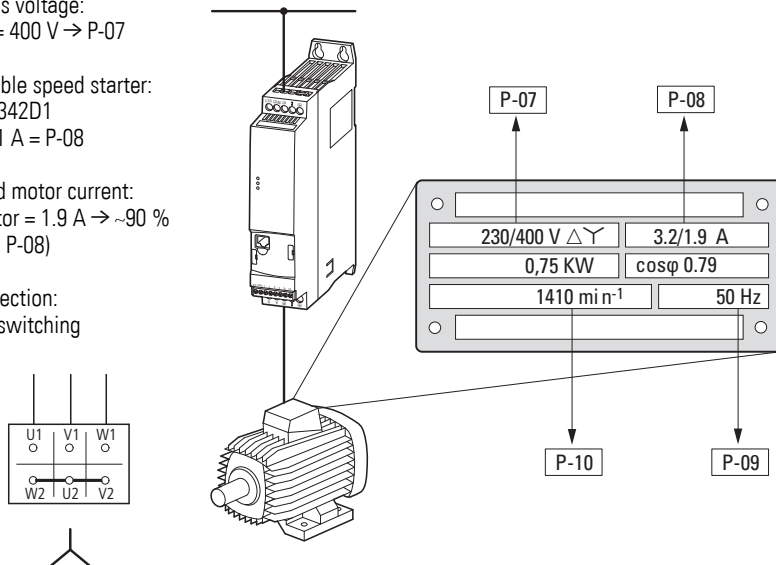
Variable speed starter:
 DE1-342D1
 $\rightarrow 2.1\text{ A} = \text{P-08}$

Rated motor current:
 I Motor = 1.9 A $\rightarrow \sim 90\%$ (from P-08)

Connection:
 Star switching

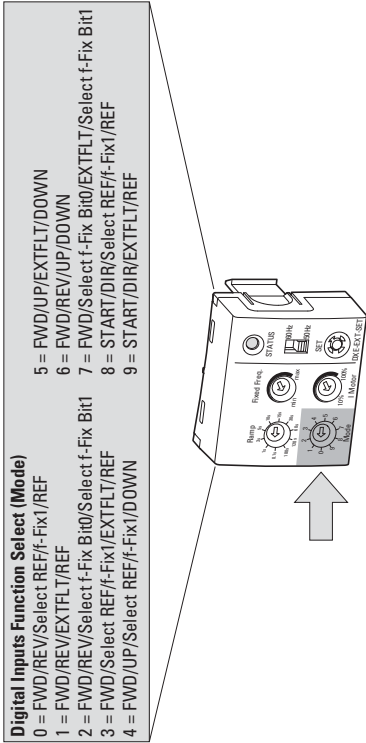
Potentiometer I Motor

The I Motor potentiometer can be used to adjust the value of the motor current (P-08) for the motor protection function (I x t) to a value between 10 % and 100 % of the DE1... variable speed starter's rated operational current. The set percentage value needs to be activated in STOP mode by pressing the SET button (and holding it down for 2 seconds) (the STATUS LED will flash three times for 2 seconds and will then show a continuous green light).



5 DXE-EXT-SET configuration module

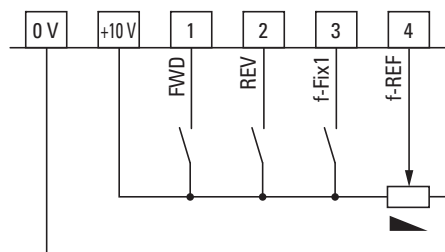
5.3 Description and use

Element	Behavior	Description
 <p>Digital Inputs Function Select (Mode)</p> <ul style="list-style-type: none"> 0 = FWD/REV/Select REF/f-Fix1/REF 1 = FWD/REV/EXTFLT/REF 2 = FWD/REV/Select f-Fix Bit0/Select f-Fix Bit1 3 = FWD/Select REF/f-Fix1/EXTFLT/REF 4 = FWD/UP/Select REF/f-Fix1/DOWN 5 = FWD/UP/EXTFLT/DOWN 6 = FWD/REV/UP/DOWN 7 = FWD/Select f-Fix Bit0/EXTFLT/Select f-Fix Bit1 8 = START/DIR/Select REF/f-Fix1/REF 9 = START/DIR/EXTFLT/REF 		<p>Mode selector switch</p> <p>The 10-setting Mode selector switch can be used to configure the DE1... variable speed starter's control terminals.</p> <p>The Mode selector switch can only be used if P-12 = 0.</p> <p>Acronyms and function designations:</p> <p>FWD = Clockwise rotating field (start command) REV = Counterclockwise rotating field (start command) f-Fix1 = Fixed frequency 1 (20 Hz = P-20) REF = Frequency reference value (0 - +10 V analog input) EXT FLT = External fault message (if the terminal is open) f-Fix Select B0, f-Fix Select B1¹ = Fixed frequencies (binary-coded) UP = Increase frequency reference value DOWN = Lower frequency reference value START = Enable signal in combination with DIR DIR = Operating direction reversal (L = FWD ↔ H = REV)</p> <p>Device parameters:</p> <p>FWD REV f-Fix1 Frequency reference value EXT FLT f-Fix Select B0; f-Fix Select B1 UP DOWN START DIR</p>

Mode 0

Default settings

With two operating directions (FWD, REV);
frequency reference value via potentiometer
(0 - +10 V) or via fixed frequency (FF1 = 20 Hz).



Mode 1

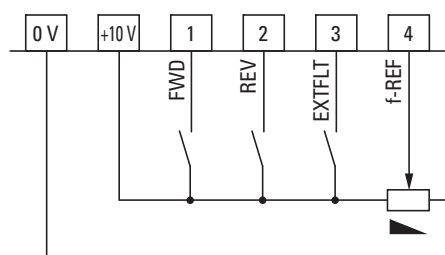
external fault message

With two operating directions (FWD, REV);
frequency reference value via potentiometer
(0 - +10 V).

An external fault message (EXT FLT) can be connected to input DI3. There must be a high signal (= control voltage) at DI3 (fail-safe) in order for the device to be able to run.

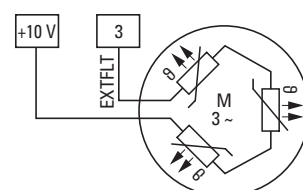
If the contact is opened (low signal), the DE1... variable speed starter will show the following LED fault message:

- Status: The LED will show a continuous red light
- Fault Code: The LED will flash with two pulses (2 pulses – external fault)



Note:

If using directly connected thermistors, take the insulation class into account!



Example showing an external fault message configuration:
Thermistor (PTC) connection.

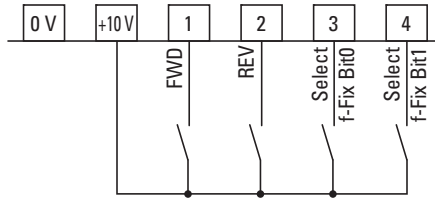
A fault message will be produced at resistances equal to or greater than 3,600 Ω and automatically reset at resistances of less than 1,600 Ω.

Element	Behavior	Description
---------	----------	-------------

Mode 2

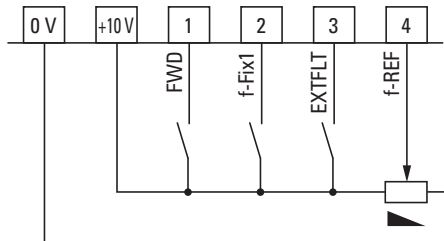
Fixed frequencies (1)
 Frequency reference value via potentiometer (0 - +10 V) or via fixed frequency reference value via binary-coded inputs.

Fixed frequency	Select f-Fix Bit0	Select f-Fix Bit1	f ₂	Parameter
f-Fix1	L	L	20 Hz	P-20
f-Fix2	H	L	30 Hz	P-21
f-Fix3	L	H	40 Hz	P-22
f-Fix4	H	H	50 Hz	P-23



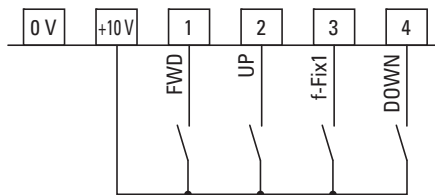
Mode 3

one operating direction (FWD)
 Frequency reference value via potentiometer (0 - +10 V) or via fixed frequency (FF1 = 20 Hz). An external fault message (EXTFLT) can be connected to input DI3 (see mode 1).



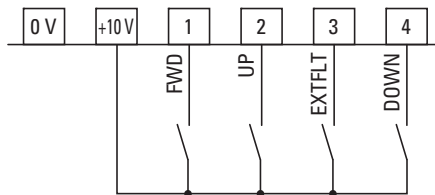
Mode 4

Digital frequency reference value (1), one operating direction (FWD).
 The frequency reference value can be set as a fixed frequency (FF1 = 20 Hz) or as a digital reference value. This digital frequency reference value can be increased with the UP control command and lowered with the DOWN control command. If UP and DOWN are activated at the same time, DOWN will register.



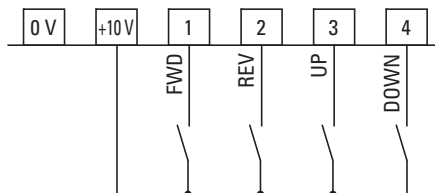
Mode 5

digital frequency reference value (2)
 One operating direction (FWD); digital frequency reference value set with the UP (increase) and DOWN (lower) control commands. If UP and DOWN are activated at the same time, the frequency reference value will be set to zero. An external fault message (EXTFLT) can be connected to input DI3 (see mode 1).



Mode 6

digital frequency reference value (3)
 Two operating directions (FWD, REV); digital frequency reference value set with the UP (increase) and DOWN (lower) control commands. If UP and DOWN are activated at the same time, DOWN will register.



5 DXE-EXT-SET configuration module

5.3 Description and use

Element	Behavior	Description																									
<p>Mode 7 Fixed frequencies (2) One operating direction (FWD); fixed frequency reference value via binary-coded inputs:</p> <table border="1"> <thead> <tr> <th>Fixed frequency</th> <th>Select f-Fix Bit0</th> <th>Select f-Fix Bit1</th> <th>f₂</th> <th>Parameter</th> </tr> </thead> <tbody> <tr> <td>f-Fix1</td> <td>L</td> <td>L</td> <td>20 Hz</td> <td>P-20</td> </tr> <tr> <td>f-Fix2</td> <td>H</td> <td>L</td> <td>30 Hz</td> <td>P-21</td> </tr> <tr> <td>f-Fix3</td> <td>L</td> <td>H</td> <td>40 Hz</td> <td>P-22</td> </tr> <tr> <td>f-Fix4</td> <td>H</td> <td>H</td> <td>50 Hz</td> <td>P-23</td> </tr> </tbody> </table> <p>An external fault message (EXTFLT) can be connected to input DI3 (see mode 1).</p>	Fixed frequency	Select f-Fix Bit0	Select f-Fix Bit1	f ₂	Parameter	f-Fix1	L	L	20 Hz	P-20	f-Fix2	H	L	30 Hz	P-21	f-Fix3	L	H	40 Hz	P-22	f-Fix4	H	H	50 Hz	P-23		<p>The diagram shows a terminal block with six positions: 0V, +10V, 1, 2, 3, and 4. Position 1 is labeled 'FWD', position 2 is 'Select f-Fix Bit0', position 3 is 'EXTFLT', and position 4 is 'Select f-Fix Bit1'. Each of these four positions has a switch connected to a common bus line. The 0V and +10V positions are also connected to this bus line.</p>
Fixed frequency	Select f-Fix Bit0	Select f-Fix Bit1	f ₂	Parameter																							
f-Fix1	L	L	20 Hz	P-20																							
f-Fix2	H	L	30 Hz	P-21																							
f-Fix3	L	H	40 Hz	P-22																							
f-Fix4	H	H	50 Hz	P-23																							
<p>Mode 8 Machine control (1) ENA enable signal The operating direction will be determined based on the DIR (Low = FWD / High = REV) control command. The frequency reference value is set via the potentiometer (0 - +10 V) or via the fixed frequency (FF1 = 20 Hz).</p> <p>Note: If there is a wire breakage at DI2 (DIR = REV), the operating direction will be reversed automatically (FWD)!</p>		<p>The diagram shows a terminal block with six positions: 0V, +10V, 1, 2, 3, and 4. Position 1 is labeled 'ENA', position 2 is 'DIR', position 3 is 'f-FIX1', and position 4 is 'f-REF'. Positions 1, 2, and 3 have switches connected to a common bus line. Position 4 has a potentiometer connected to the bus line. The 0V and +10V positions are also connected to this bus line.</p>																									
<p>Mode 9 Machine control (2), ENA enable signal The operating direction will be determined based on the DIR (Low = FWD / High = REV) control command. The frequency reference value is set via the potentiometer (0 - +10 V). An external fault message (EXTFLT) can be connected to input DI3 (see mode 1).</p> <p>Note: If there is a wire breakage at DI2 (DIR = REV), the operating direction will be reversed automatically (FWD)!</p>		<p>The diagram shows a terminal block with six positions: 0V, +10V, 1, 2, 3, and 4. Position 1 is labeled 'ENA', position 2 is 'DIR', position 3 is 'EXTFLT', and position 4 is 'f-REF'. Positions 1, 2, and 3 have switches connected to a common bus line. Position 4 has a potentiometer connected to the bus line. The 0V and +10V positions are also connected to this bus line.</p>																									

6 Parameter

Following is a description of the DE1... variable speed starter's parameters and functions.

These parameters can be accessed using the device's front RJ45 interface and require optionally available interface converters in order to be displayed and adjusted:

- DX-KEY-LED2 keypad with the corresponding 3 m-long patch cable with RJ45 connectors
- DX-CBL-PC-3M0 interface converter (RJ45 to USB, with 3 m-long cable) for connecting to a computer with the drivesConnect parameter configuration program.
- DX-COM-STICK3 communication stick used for copying and saving parameters to other devices of DE1... series as well as for establishing wireless activation (Bluetooth) on a PC with **drivesConnect** parameter software or a smartphone with the **drivesConnect mobile app**.



The interface converters listed here are not provided as standard with the DE1... variable speed starter.



The **drivesConnect mobile app** can be installed by visiting the following link:

www.eaton.eu/DE/Europe/Electrical/CustomerSupport/MobileApplications/index.htm

6 Parameter

6.1 RJ45 interface

6.1 RJ45 interface

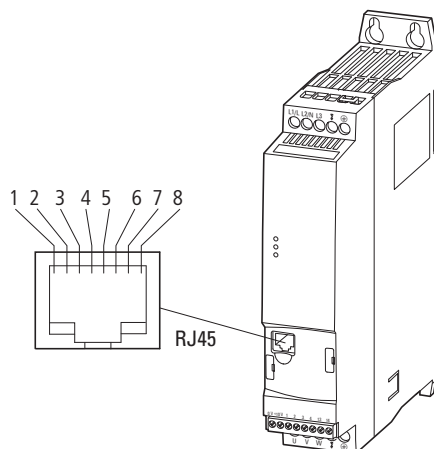


Figure 54: RJ 45 interface

Table 15: Pin assignment of the RJ45 interface

Pin	Description
1	CAN_L (only for DE11...)
2	CAN_H (only for DE11...)
3	0 V
4	OP bus (Operation Bus) / External keypad / -PC connection
5	OP bus (operation bus) / External keypad / +PC connection
6	+24 V, DC power supply
7	RS485- / Modbus RTU (A)
8	RS485+ / Modbus RTU (B)

6.2 DX-KEY-LED2 external keypad

The optional DX-KEY-LED2 keypad for DE1... variable speed starters can be used to easily configure a device's parameters. It comes with a 3 m-long connection cable (patch cable with RJ45 plugs).

The connection can be achieved using the DE1... variable speed starter's RJ45 interface, which is located at the front of the device.



The DX-KEY-LED2 keypad is not included as standard with the DE1... variable speed starter.

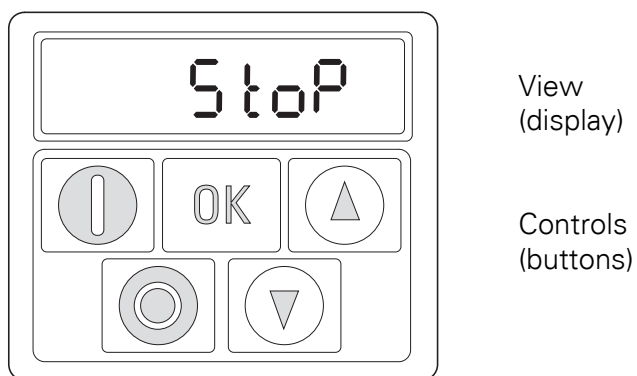
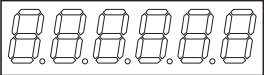

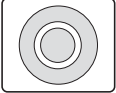





Figure 55: DX-KEY-LED2 operating unit view

6 Parameter

6.2 DX-KEY-LED2 external keypad

Table 16: DX-KEY-LED2 keypad description

Operating unit element	Explanation
	<p>7-segment LED display Six-digit display with decimal points</p>
	<p>Start button Motor start with the pre-selected operating direction (FWD, REV):</p> <ul style="list-style-type: none"> • see parameter P-12 (e.g. P-12 = 1) • Enable signal (+10 - 24 V) to DI1 (FWD) or DI2 (REV) <p>Note: If P-24 = 2 or 3, the START button will be locked.</p>
	<p>Stop button</p> <ul style="list-style-type: none"> • Stops the running motor with the stop mode set in P-05: <ul style="list-style-type: none"> • see parameter P-12 (e.g. P-12 = 1) • Enable signal (+10 - 24 V) at DI1 (FWD) or DI2 (REV) • Example: If P-05 = 1, the drive will stop with the deceleration time set in P-04 • Reset – used to reset fault messages. <p>Note: If P-24 = 2 or 3, the STOP button will be locked.</p>
	<p>OK button</p> <ul style="list-style-type: none"> • Used to switch the display value between Hz / rpm and A • Parameter input – used to activate the parameter input function (editing mode; hold down for 2 s) • Change parameter value – used to start changing a parameter value (the display value will flash) • Save – used to confirm and activate the set parameter value (hold down for 2 s)
	<p>UP button</p> <ul style="list-style-type: none"> • Used to increase the numeric value or parameter number (exponentially) • Used to increase the output frequency (motor speed) (see parameters P-12 and P-24)
	<p>DOWN button</p> <ul style="list-style-type: none"> • Used to lower the numeric value or parameter number (exponentially) • Used to lower the output frequency (motor speed) (see parameters P-12 and P-24)

7-segment LED display

The display unit is a 7-segment LED display with five decimal points. The LED segments are red.

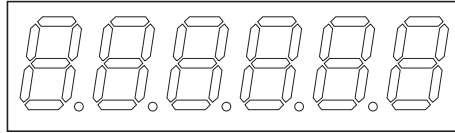


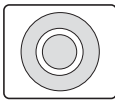

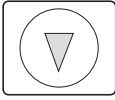
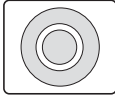
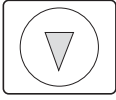





Figure 56: 7-segment LED display

- ➔ In the event of a motor overload (see parameter P-08), the five decimal points will flash.
- ➔ If the device's parameters are locked (see parameter P-39), the left segment will show an *L* ("Lock").

When the required supply voltage is applied (connection terminals L1/L, L2/N, L3), the DE1... variable speed starter will automatically run a self-test. The plugged-in keypad's display will show *ScRn-LdPd* in succession and then, depending on the operating mode, will show *StdP* or the relevant operating values (Hz, rpm, A).

6.2.1 Key combinations

Table 17: Key combinations of keypad

Function	Key combination
Keypad address (keypad port) on an OP bus	 +  + 
DE1... variable speed starter address	 + 
Fan and display test (FS2) 1) Press the button first	 ¹⁾ +  +  +  + 

6 Parameter

6.2 DX-KEY-LED2 external keypad

6.2.2 Parameter structure

When using a DX-KEY-LED2 keypad, the DE1... variable speed starter's parameters will be accessed in a closed ring configuration, figuratively speaking. To start selecting parameters, press the OK button and hold it down for 2 seconds. The P-01 parameter will be displayed. To select a different parameter (up to P-14), use the two arrow keys (UP, DOWN). To access the extended parameter set, enter 101 (= P-38, default setting) in parameter P-14. The corresponding parameters will be added to the "ring". To open an additional "ring" with display parameters (P00-01 to P00-20), press the OK button while on the P-00 parameter in the extended parameter set.

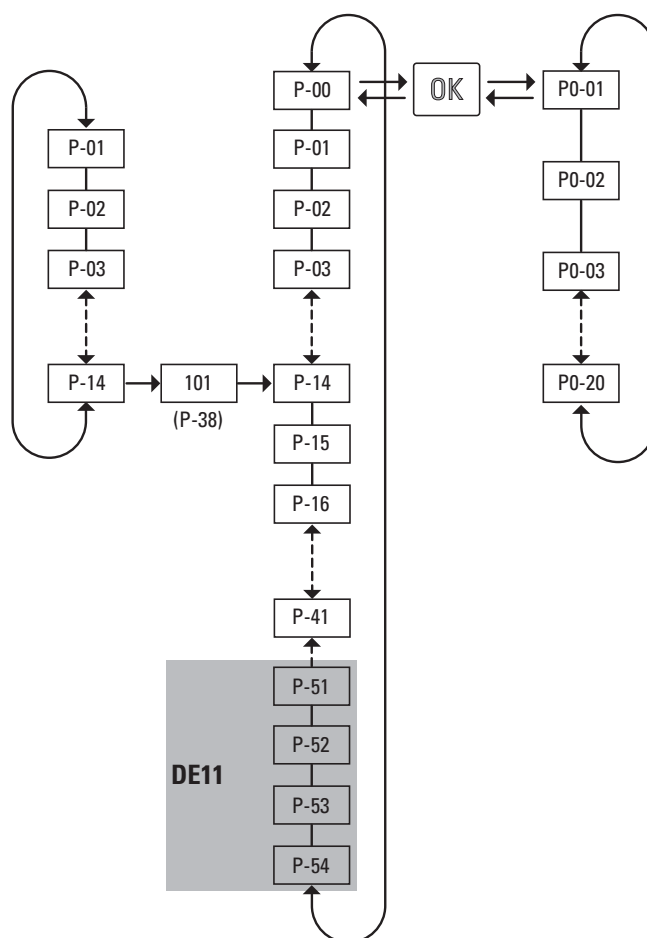


Figure 57: Parameter structure




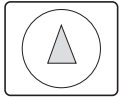




The value for unlocking the advanced parameter set is defined in parameter P-38 (default setting: 101).

6.2.3 Setting parameters

Table 18 below provides an example that illustrates how to operate the external DX-KEY-LED2 keypad in order to select and adjust the P-02 (f-min) parameter when a minimum speed (frequency) needs to be set for a drive.

Table 18: Example showing how to adjust a parameter

Sequence	Commands	View	Description
0		<i>StoP</i>	Stop state: The DE1... variable speed starter is ready for operation.
1		<i>P-01</i>	Hold down the OK button for about two seconds. The display will switch to parameter P-01 (number 1 on the right will flash).
2		<i>P-02</i>	Press the (UP) arrow key. The display will switch to parameter P-02 (number 2 on the right will flash).
3		<i>H 00</i>	Press OK button The display will switch to the input level for parameter P-02 (number 0 on the right will flash) and will show a value of 0.0 Hz if the parameter is still configured with its default setting.
4		<i>H 20.0</i>	The desired value (e.g., 20 Hz) can be set by using the (UP) arrow key: <ul style="list-style-type: none"> • Press briefly → The value will be incremented step by step • Hold down → The value will increase exponentially
5		<i>P-02</i> <i>StoP</i>	<ul style="list-style-type: none"> • Press the OK button. The value set for P-02 (f-min = 20.0 Hz) will be stored. The display will switch to the parameter level and show P-02 (the number on the right will flash). Use the arrow keys (UP, DOWN) to select another parameter. • Press and hold down the OK button for about two seconds. The value set for P-02 (f-min = 20.0 Hz) will be stored and the display will leave the parameter level and show <i>StoP</i> instead.
6		<i>H 20.0</i> <i>StoP</i>	<ul style="list-style-type: none"> • P-02 on display (the number on the right will flash). • Press the OK button. The display will switch back to the input level for P-02. You can then change the value (f-min = 20.0 Hz) if you want (see step 4). • Press and hold down the OK button for about two seconds. The display will leave the parameter level and show <i>StoP</i> instead.



If a setting entered at the parameter level is not confirmed with the OK button and no further buttons are pressed for about 20 seconds, the set value will not be stored and the display will automatically leave the parameter level. The display will then show *StoP* instead.

When the setting in table 18 is used and an enable signal (FWD, REV) is given, the DE1... variable speed starter will start the motor with the configured acceleration ramp (P-03) and get it to 20 Hz (= f-min) if the frequency reference value (f-REF) is zero.

A frequency reference value of 0 to 10 V, for example, can be used to adjust the drive's speed from 20 Hz (= f-min) to f-max (P-09).

6 Parameter

6.3 drivesConnect

6.3 drivesConnect



Figure 58: Main drivesConnect components on start screen

The drivesConnect parameter configuration software can be used with a computer to quickly configure, operate, and diagnose a DE1... variable speed starter, as well as to document its settings (by printing and saving parameter lists) and transfer data. The program can be downloaded from the Internet (www.eaton.eu) and installed. drivesConnect can run on the Windows 10, Windows 8, Windows 7, and Windows XP operating systems. Older Windows operating systems are not supported.

To connect a computer with drivesConnect to the DE1... variable speed starter, you will need to use the starter's front RJ45 interface and either the DX-CBL-PC-3M0 interface converter or the DX-COM-STICK3 Bluetooth connection module.



For more information on the drivesConnect program and the required accessories (DX-CBL-PC-3M0 or DX-COM-STICK3), please refer to the appendix.



The drivesConnect program can be installed by visiting the following link:

www.drive-support-studio.com/OTS/Eaton/downloads/deploy/drivesConnect.htm

6.4 SmartWire-DT

The centrally controlled SmartWire-DT wiring system can be used to cyclically configure the parameters of and control the DE1... variable speed starter.

The SmartWire-DT system requires a special 8-pin connecting cable, as well as the corresponding plugs.

To connect the DE1... variable speed starter to the SmartWire-DT wiring system, you will need the optionally available DX-NET-SWD3 interface module. This module needs to be plugged into the DE1... variable speed starter's front RJ45 port (→ section 9.3, "SmartWire-DT DX-NET-SWD3", page 136).

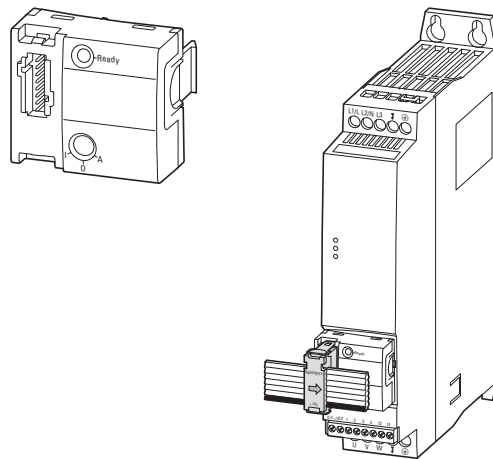


Figure 59: DX-NET-SWD3 SmartWire-DT interface card



For more information, as well as a detailed description of the SmartWire-DT connection, please refer to manual MN04012009Z-EN, "DX-NET-SWD SmartWire-DT Interface Card for PowerXL™ Variable Frequency Drives".

6 Parameter

6.5 Parameter description

6.5.1 Parameter description

The parameter descriptions found below use a series of abbreviations and acronyms. These abbreviations and acronyms are defined in the following table:

Abbreviation	Meaning
Modbus ID	The parameter's identification number in Modbus (IDentification number)
RUN	The parameter can be accessed during operation (Run signal)
STOP	The parameter can only be accessed in STOP mode
ro/rw	Parameter read and write permissions: ro = read only rw = read and write
Name	Short parameter name
Value	Setting value of the parameter value range Display value
DS	Default setting (the parameter's value when using the device's factory settings). The values in parentheses are the default settings when using a frequency of 60 Hz.
Page	The page number in this manual containing a detailed description of the parameter.

6.5.1 Acceleration and deceleration time

Table 19: Ramp time parameters

Panel Code	Modbus ID	Access right		Name	Value	DS	Description
		RUN, STOP	ro/rw				
P-01	129	STOP	rw	f-max	P-02 - 250.0 (300.0) Hz	50 Hz (60 Hz)	Sets the upper limit for the speed of the motor. This can be set to any value between "f-min" and 5x the "motor nom frequency". "Motor Nom Speed" (P-10) = 0, the maximum speed limit will be displayed in Hz. "Motor Nom Speed" (P-10) > 0, the maximum speed limit will be displayed in rpm.
P-02	130	STOP	rw	f-min	0 Hz - P-01	0 Hz	Sets the lower limit for the speed of the motor This can be set to any value between 0 and "f-max" (P-01) "Motor Nom Speed" (P-10) = 0, the minimum speed limit will be displayed in Hz. "Motor Nom Speed" (P-10) > 0, the minimum speed limit will be displayed in rpm.
P-03	131	RUN	rw	t-acc	0.1 - 300 s	5.0 s	Sets the acceleration ramp time in seconds. The time interval set in "t-acc" represents the time taken to accelerate from zero to "Motor Nom Frequency" (P-09).

6 Parameter

6.5 Parameter description

Panel Code	Modbus ID	Access right		Name	Value	DS	Description
		RUN, STOP	ro/rw				
P-04	132	RUN	rw	t-dec	0.1 - 300 s	5.0 s	Sets the deceleration ramp time in seconds. The time interval set in "t-dec" represents the time taken to decelerate from "Motor Nom Frequency" (P-09) to zero.
P-05	133	RUN	rw	Stop mode	0; 1	1	Determines the action taken by the drive in the event of the drive enable signal being removed. 0 : Coasting. When the enable signal is removed, the drive output is immediately disabled, and the motor will coast (freewheel) to stop. 1: Ramping. When the enable signal is removed, the drive will ramp to stop, with the rate controlled by "t-dec" (P-04).
P-31	159	RUN	rw	Overvoltage Control	0; 1	0	The over voltage control prevents the drive from tripping in case of regenerative energy feedback from the motor to the DC link. When disabled, the drive will trip "Over Voltage" instead of automatically increasing the motor ramp times when the drive is decelerating the motor too quickly. 0: ON. Overvoltage Controller enabled 1: OFF. Overvoltage Controller disabled

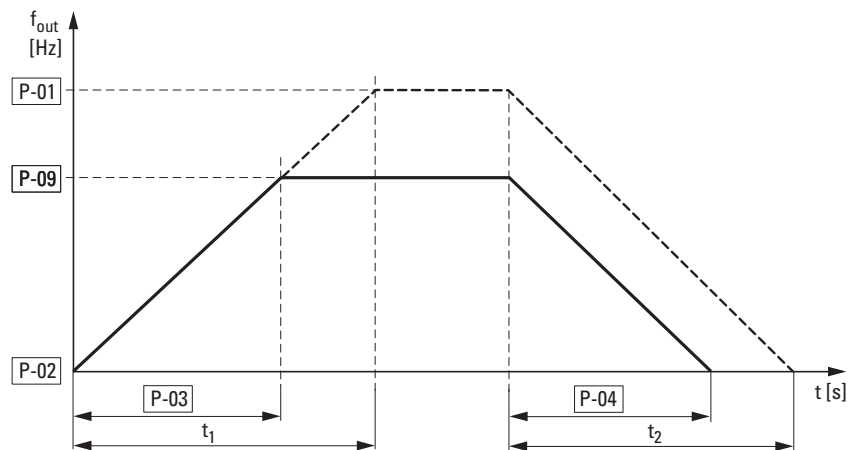


Figure 60: Acceleration and deceleration time



The reference points for the acceleration and deceleration times configured in P-03 and P-04 are always 0 Hz and the motor's rated frequency (P-09).

6 Parameter

6.5 Parameter description

The following formulas can be used to calculate acceleration time t_1 and deceleration time t_2 (relative to the motor's rated frequency (P-09)) for a maximum output frequency P-01:

$$t_1 = \frac{P-01 \times P-03}{P-09}, \quad t_2 = \frac{P-01 \times P-04}{P-09}$$

If there is a given acceleration time t_1 and a given deceleration time t_2 , the set values for P-03 (t-axx) and P-04 (t-dec) can be calculated as follows for a higher output frequency (P-01):

$$P-03 = \frac{t_1 \times P-09}{P-01}, \quad P-04 = \frac{t_2 \times P-09}{P-01}$$



The defined acceleration (P-03) and deceleration times (P-04) apply for all changes to the frequency reference value (f-REF).

If the value set for f-min (P-02) is different from 0 Hz, the drive will accelerate with the acceleration time configured in P-03 to a value of f-min in time t_{f-min} after receiving an enable signal (FWD, REV).

Example

P-02 = 20 Hz (= f-min), P-03 = 5 s, P-09 = 50 Hz

$$t_{f-min} = \frac{P-02 \times P-03}{P-09} = \frac{20 \text{ Hz} \times 5 \text{ s}}{50 \text{ Hz}} = 2 \text{ s}$$

The overvoltage control function (default setting: P-31 = 0) will monitor the DC link voltage's magnitude and prevent the DE1... variable speed starter from being switched off if the motor's energy recovery results in the DC link voltage exceeding its limits. The output frequency will be automatically adjusted (U/f).

The fault message in the event of an excessive DC link voltage when P-31 = 1 will be: **Fault Code** LED: 3 pulses – overvoltage.



During continuous operation, excessive DC link voltage may result in the motor's speed being temporarily increased. If deceleration ramp P-04 is active, this frequency increase will result in the ramp being lengthened.

6.5.2 Motor data

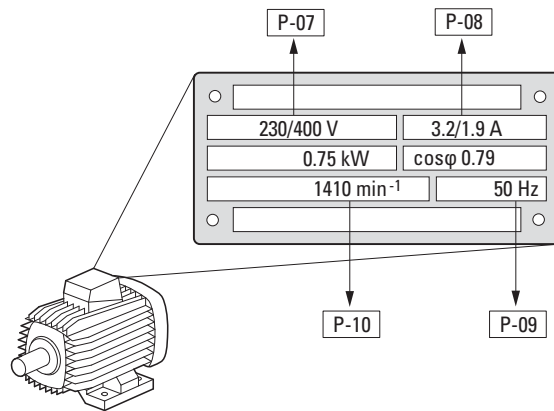


Figure 61: Motor parameters from ratings plate

➔ When the DE1... variable speed starter is used with its default settings, the motor data (P-07, P-08, P-09) will match the starter's rated operational data. This means that the default motor data will depend on the DE1... model being used.

➔ Parameter P-10 will be set to 0 by default, i.e., to the V/f frequency control mode. If the motor speed is set here, slip compensation will be automatically activated and all frequency-based parameters will be shown in rpm, ➔ table 23, page 96.

When selecting the rating data, take the dependency of the circuit types on the mains voltage into account:

- 230 V in P-07 ➔ Delta circuit ➔ P-08 = 3.2 A
- 400 V in P-07 ➔ Star connection ➔ P-08 = 1.9 A

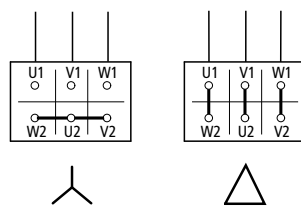


Figure 62: Circuits (delta, star)

6 Parameter

6.5 Parameter description

Table 20: Parameters P-07, P-08, P-09, P-10

Panel Code	Modbus ID	Access right		Name	Value	DS	Description
		RUN, STOP	ro/rw				
P-07	135	STOP	rw	Motor Nom Voltage	50 - 500 V	220 V, 230 V, 380 V, 400 V, 460 V	Defines the Motor rated voltage. When the output frequency is greater than the "Motor Nom Frequency" (P-09), the output voltage is controlled at the level set with "Motor Nom Voltage" (P-07).
P-08 ¹⁾	136	STOP	rw	Motor Nom Current	(10 - 100 %) I _e	I _e	Motor rated current. By setting the "Motor Nom Current" in the speed starter, the motor overload protection is configured to match the motor rating. When the measured motor current exceeds "Motor Nom Current", the decimal points on the display (option) will flash to indicate an overload condition. If this condition persists, the speed starter will eventually trip, displaying <i>I . E - E r P</i> , preventing thermal overload of the motor.
P-09	137	STOP	rw	Motor Nom Frequency	20.0 - 300 Hz	50 Hz (60 Hz)	The rated frequency of the motor. This is the frequency at which "Motor Nom Voltage" is applied to the motor. Below this frequency, the applied motor voltage will be reduced. Above this frequency the voltage remains limited to "Motor Nom Voltage".
P-10	138	STOP	rw	Motor Nom Speed	0/200 - 18000 rpm	0	Motor rated speed P-10: 0: the speed of the motor will be displayed in Hz. P-10 > 0: the speed related parameters (f-max, f-min etc.) will be displayed in rpm. The slip compensation is also activated, where the shaft speed of the motor is maintained under varying load conditions by compensating for the load-dependent slip of the motor. If "Motor Nom Speed": motor synchronous speed (e.g. 3000rpm for a 2-pole 50 Hz motor), the speed can be displayed in rpm without activating the slip compensation.

1) The parameter's values will not be copied if the parameters are copied to a DE1... variable speed starter with a different output rating.

6.5.3 Motor protection

6.5.3.1 Overload protection (I x t)

In order to protect the motor against thermal overload, a thermal motor model with an I x t characteristic will be computed in the DE1... variable speed starter based on the value in parameter P-08. If the rated motor current is lower than the DE1...’s rated operational current, you will need to enter this lower value in parameter P-08 or set it using the I-Motor potentiometer in the DXE-EXT-SET configuration module.



Motor protection can also be implemented by using an overload relay, thermistors, etc.

NOTICE

The thermal model will not protect the motor if there is reduced cooling due to dirt, dust, etc.

The computed thermal motor model will be automatically saved when the supply voltage is switched off and used as a basis for additional calculations when the supply voltage is switched back on. When P-33 = 1, it is automatically set to 0.

If the motor current is higher than the value set in P-08 (I x t) for an extended period of time, the DE1... variable speed starter will be automatically switched off with the following fault message:

- **Fault Code** LED: 1 pulse – overload.
- DX-KEY-LED2: *I.L - t r P*. The overload duration up until the moment the device is switched off will be shown by flashing decimal points.



The fault message must be reset by deactivating the enable signal (FWD, REV), by pressing the STOP button on the keypad, or by switching off the mains voltage.

6 Parameter

6.5 Parameter description

Table 21: Parameter P-33

Panel Code	Modbus ID	Access right		Name	Value	DS	Description
		RUN, STOP	ro/rw				
P-33	161	STOP	rw	T-Memory Enable	0; 1	0	When enabled, the motor thermal memory retention function will save the calculated motor thermal history on drive power down, using this saved value as the starting value on next power up. If this function is disabled, the motor thermal history is reset to zero on every power up. 0: ON. Thermal memory enabled 1: OFF. Thermal memory disabled

6.5.3.2 Thermistor protection

Measuring the temperature in the motor's stator windings is the most effective way to protect the motor against thermal overload. DE1... variable speed starters make it possible to directly connect temperature sensors with a positive temperature coefficient (PTC):

- Thermistor
- Temperature switch (Thermo-Click)

NOTICE

DE1... variable speed starters are built in accordance with IEC/EN 61800-5-1. This requires double insulation between mains supply circuits and low-voltage circuits. Accordingly, thermistors in the motor must have double insulation relative to the motor winding in order not to negatively affect the PDS' entire insulation system.

The thermistor needs to be connected between +10 V and DI3 (control terminals +10 V and 3). In P-15 = 1 / 3 / 5 / 7 / 9 configurations, it will be used as an external fault message source (EXTFLT).

The DE1... variable speed starter will be automatically switched off at a resistance of 3600 Ω with the following fault message:

- **Fault Code** LED: 2 pulses – external fault
- DX-KEY-LED2: $E - t_r \cdot I^2$

Once the motor winding cools down (= the thermistors cool down), the fault message can be reset, provided the resistance has fallen below 1,600 Ω.

6 Parameter

6.5 Parameter description

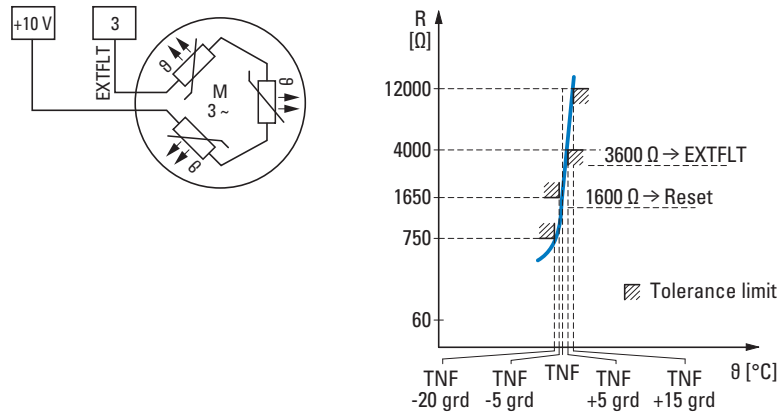


Figure 63: Connection example with thermistor and trip characteristic

Table 22: Parameters P-15, P-19

Panel Code	Modbus ID	Access right		Name	Value	DS	Description																																																							
		RUN, STOP	ro/rw																																																											
P-15	143	STOP	rw	DI Configuration Selection	0, 1, ... ,9	0	<p>Function of the control terminals</p> <p>When P-12 = 0, control signal terminals DI1 to DI4 can be configured with the following functions:</p> <table border="1"> <thead> <tr> <th>Mode</th> <th>DI1</th> <th>DI2</th> <th>DI3</th> <th>AI1/DI4</th> </tr> </thead> <tbody> <tr> <td>0</td> <td>FWD</td> <td>REV</td> <td>Select REF/f-Fix1</td> <td>REF</td> </tr> <tr> <td>1</td> <td>FWD</td> <td>REV</td> <td>EXTFLT</td> <td>REF</td> </tr> <tr> <td>2</td> <td>FWD</td> <td>REV</td> <td>Select f-Fix Bit0</td> <td>Select f-Fix Bit1</td> </tr> <tr> <td>3</td> <td>FWD</td> <td>Select REF/f-Fix1</td> <td>EXTFLT</td> <td>REF</td> </tr> <tr> <td>4</td> <td>FWD</td> <td>UP</td> <td>Select REF/f-Fix1</td> <td>DOWN</td> </tr> <tr> <td>5</td> <td>FWD</td> <td>UP</td> <td>EXTFLT</td> <td>DOWN</td> </tr> <tr> <td>6</td> <td>FWD</td> <td>REV</td> <td>UP</td> <td>DOWN</td> </tr> <tr> <td>7</td> <td>FWD</td> <td>Select f-Fix Bit0</td> <td>EXTFLT</td> <td>Select f-Fix Bit1</td> </tr> <tr> <td>8</td> <td>START</td> <td>DIR</td> <td>Select REF/f-Fix1</td> <td>REF</td> </tr> <tr> <td>9</td> <td>START</td> <td>DIR</td> <td>EXTFLT</td> <td>REF</td> </tr> </tbody> </table> <p>Note: The assigned control signal terminal functions will depend on the value set in P-12.</p>	Mode	DI1	DI2	DI3	AI1/DI4	0	FWD	REV	Select REF/f-Fix1	REF	1	FWD	REV	EXTFLT	REF	2	FWD	REV	Select f-Fix Bit0	Select f-Fix Bit1	3	FWD	Select REF/f-Fix1	EXTFLT	REF	4	FWD	UP	Select REF/f-Fix1	DOWN	5	FWD	UP	EXTFLT	DOWN	6	FWD	REV	UP	DOWN	7	FWD	Select f-Fix Bit0	EXTFLT	Select f-Fix Bit1	8	START	DIR	Select REF/f-Fix1	REF	9	START	DIR	EXTFLT	REF
Mode	DI1	DI2	DI3	AI1/DI4																																																										
0	FWD	REV	Select REF/f-Fix1	REF																																																										
1	FWD	REV	EXTFLT	REF																																																										
2	FWD	REV	Select f-Fix Bit0	Select f-Fix Bit1																																																										
3	FWD	Select REF/f-Fix1	EXTFLT	REF																																																										
4	FWD	UP	Select REF/f-Fix1	DOWN																																																										
5	FWD	UP	EXTFLT	DOWN																																																										
6	FWD	REV	UP	DOWN																																																										
7	FWD	Select f-Fix Bit0	EXTFLT	Select f-Fix Bit1																																																										
8	START	DIR	Select REF/f-Fix1	REF																																																										
9	START	DIR	EXTFLT	REF																																																										
P-19	147	STOP	rw	DI3 Logic	0; 1	0	<p>This parameter defines the logic of the digital input 3.</p> <p>0: High = ok, Low = Fault 1: Low = ok, High = Fault (when P15 is set to 1, 3, 5, 7 or 9 (External Fault))</p>																																																							

6 Parameter

6.5 Parameter description

6.5.4 V/f characteristic curve

The inverter in the DE1... variable speed starter works using sinusoidal pulse width modulation (PWM). With it, the IGBTs are driven with two V/Hz control-based control methods that have the following characteristics:

V/f (P-10 = 0)

- Frequency control (Hz),
- Parallel connection of several motors possible,
- Large power difference between the DE1... variable speed starter and the motor ($P_{DE1} \gg P_{Motor}$).
- Switching in the output.

V/f with slip compensation (P-10 \geq 200)

- Speed control with slip compensation,
- All frequency-based parameters will be shown in revolutions per minute (min^{-1} , rpm).
- Single-motor operation (only one connected motor). The power difference must be, at most, one factor lower than that of the DE1... variable speed starter.

Table 23: Parameter P-06, P-11

Panel Code	Modbus ID	Access right		Name	Value	DS	Description
		RUN, STOP	ro/rw				
P-06	134	STOP	rw	Energy-Optimizer	0; 1	0	When energy optimization is activated, the motor voltage is dynamically varied, dependent on load. This results in reduced voltage being applied to the motor on light load, significantly reduce energy consumption. This mode of operation is less suitable for dynamic applications where the load conditions can suddenly increase significantly. 0: OFF 1: ON
P-11	139	RUN	rw	V-Boost	0.0 - 40.0 %	0.0 %	Voltage is used to increase the applied motor voltage at low output frequency, in order to improve low speed and starting torque. Excessive voltage boost levels may result in increased motor current and temperature, and forced ventilation may be required.

V/f Control mode

Volts per Hertz control (V/Hz characteristic) refers to the DE1... variable speed starter control method in which motor voltage is regulated so that it is maintained at a specific ratio relative to frequency.

If the voltage-to-frequency relationship is constant, this is referred to as a "linear V/Hz characteristic curve".

In a standard application, the characteristic values ① in the V/Hz characteristic curve (e.g., 400 V/50 Hz) will match the connected motor's rated operational data (refer to the motor's rating plate):

- Output voltage = Rated operating motor voltage (P-07)
- Cut-off frequency = motor rated frequency (P-09)

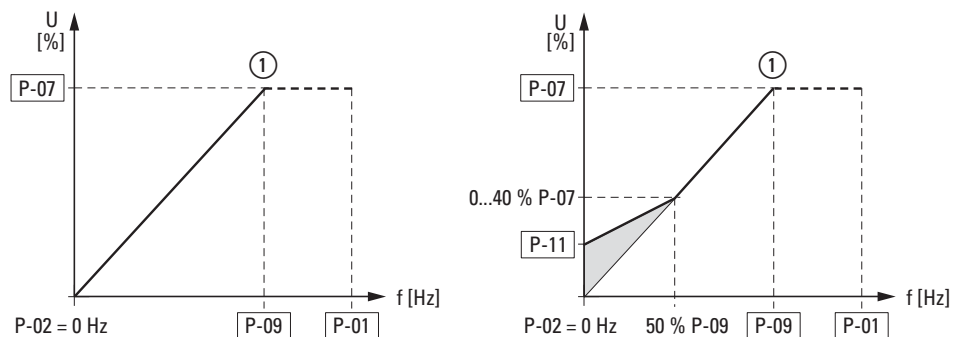


Figure 64: V/Hz Ratio

Voltage increase (Boost)

Below approx. 50 % of the motor's rated operational data, the corresponding efficiency (η) and power factor ($\cos \varphi$) will drop sharply. The runout characteristics will worsen and the current consumption will increase, with the severity of these changes depending on the type of rotor and its characteristics.

Using the voltage boost function (boost, P-11) can mitigate these effects on the starting torque and on the motor's runout characteristics at low frequencies.



The higher start voltage (boost) will result in a higher motor current and, accordingly, in increased motor heating. Increased motor cooling (external fans) may be required.

The voltage boost (P-11) can be set to values of up to 40 % of the motor's rated operating voltage (P-07). The voltage boost configured with P-11 will be effective up to approx. 50 % of the rated motor frequency (P-09).

6 Parameter

6.5 Parameter description

Energy Optimizer

If P-06 = 1, the DE1... variable speed starter's energy optimizer will be enabled, in which case the output voltage will be adjusted automatically based on the load. In partial load scenarios, this function will reduce the output voltage and, as a result, the losses in the motor. Accordingly, energy consumption levels will decrease.



Not suitable for dynamic applications with quickly changing loads!

V/Hz control with slip compensation

When run in V/Hz control mode with slip compensation (P-10 \geq 200), DE1... variable speed starters can compensate for speed fluctuations caused by loads. If the load torque increases ①, the output frequency ② and the output voltage will be automatically increased and the speed change caused by the load will be compensated for (the diagrams below show a simplified version of this concept). The set speed (n_1) will remain virtually constant. In order for the device to be able to perform an accurate calculation, the motor's exact rating plate specifications must be entered into the corresponding parameters (P-07, P-08, P-09, P-10).



When the slip compensation function is activated (P-10 \geq 200), all frequency-based parameter values will be converted and shown in revolutions per minute (min^{-1} , rpm).

In this setting, slip compensation will not be activated if a synchronous speed value is entered (e.g., 3,000 rpm for 50 Hz – this is the synchronous speed of a 2-pole motor).

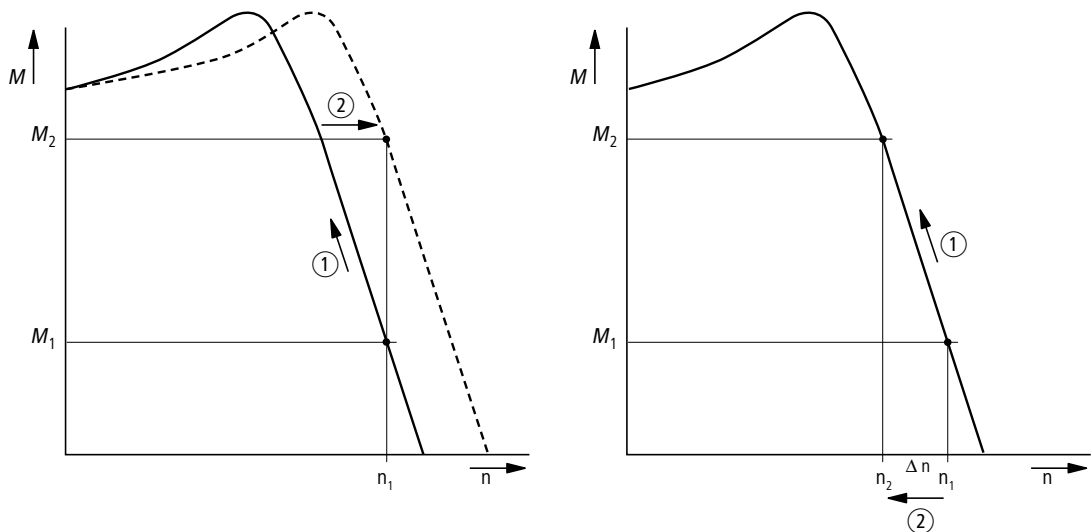


Figure 65: Speed behavior with and without slip compensation

When there is no slip compensation, load changes ① on the motor shaft will result in a greater slip (Δn) and, as a result, a change in rotor speed ②. In this case, the speed behavior of a three-phase asynchronous motor is comparable to operation on a constant AC supply system. Speed changes caused by loads ($n_1 \rightarrow n_2$) will not be compensated for.

6.5.5 DC braking

When using DC braking, DE1... variable speed starters apply a DC voltage to the stator windings of the connected three-phase motor. This makes it possible to brake motors that are already rotating (e.g., pumps and fans) before starting them, as well as to hold braked motors (e.g., handling equipment and winding gear) in a stop position for a specific time.

DC braking can be activated with parameter P-25, while parameter P-26 can be used to define the braking time (maximum: 10 seconds). The braking voltage and the resulting braking torque can be adjusted with P-27 as a percentage of nominal motor voltage P-07. Higher values will produce a higher braking torque, but will also result in increased motor heating.

If a deceleration ramp is active (P-05 = 1), parameter P-28 can be used to define an activation frequency at which the device will automatically switch to DC braking if a stop command has been issued.

If P-05 = 0 ("coasting"), DC braking will be activated as soon as a stop command is given. In this case, P-28 will be ignored.

Table 24: DC braking parameters

Panel Code	Modbus ID	Access right		Name	Value	DS	Description
		RUN, STOP	ro/rw				
P-25	153	STOP	rw	DCBrake	0, 1, 2, 3	0	Sets the instances when DC braking is enabled. 0: OFF 1: On at Stop 2: On before Start 3: On before Start and at Stop
P-26	154	RUN	rw	t-DCBrake@Stop	0 - 10 s	0.0 s	Duration of DC braking at Stop and before Start
P-27	155	RUN	rw	DCBrakeVoltage	(0 - 100 %) P-07	0.0 s	Amount of DC voltage as a percentage of the "Motor Nom Voltage" that is applied to the motor during DC braking.
P-28	156	RUN	rw	f-DCBrake@Stop	0 - P-01	0.0Hz	Output frequency in Hz at which DC braking starts during the deceleration phase. If "Stop Mode" is set to coasting, DC braking starts at stop command immediately.

6 Parameter

6.5 Parameter description

6.5.6 Control terminal configuration

Parameter P-15 can be used to configure the function of control terminals 1 through 4. When parameter P-15 is used, parameter P-12 can be used to configure access to control signals and reference values, including in combination with an external keypad, Modbus RTU, and SmartWire-DT (process data access).



In DE1... variable speed starters, the output frequency's clockwise rotating field direction (FWD) is always used as the basis and is represented with unsigned values in all ranges. Meanwhile, the inverted rotating field direction (counterclockwise rotating field REV) is represented with a minus sign.

For DE1... variable speed starters, the term "reference value" is used as a general term that encompasses analog reference values (f-REF), digital reference values (UP, DOWN), fixed frequencies (FF1 to FF4), and selecting an operating direction (FWD, REV). Meanwhile, the term "control" is used as a general term that encompasses the enable signal (ENA), the operating direction reversing signal (DIR), and the external fault message (EXTFLT).

By default (P-12 = 0, P-15 = 0), the control terminals are used to control the DE1... device and set its setpoints.

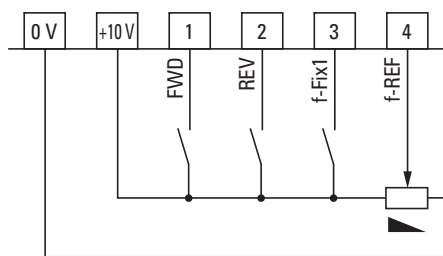


Figure 66: Default settings for control terminals

FWD = clockwise rotating field

REV = anticlockwise rotating field

f-Fix1 = fixed frequency 1 (20 Hz)

f-REF = analog frequency reference value signal (0 - +10 V = 0 - 50/60 Hz)

Digital Inputs Function Select (Mode)	
0 = FWD/REV/Select REF/f-Fix1/REF	5 = FWD/UP/EXTFLT/DOWN
1 = FWD/REV/EXTFLT/REF	6 = FWD/REV/UP/DOWN
2 = FWD/REV/Select f-Fix Bit0/Select f-Fix Bit1	7 = FWD/Select f-Fix Bit0/EXTFLT/Select f-Fix Bit1
3 = FWD/Select REF/f-Fix1/EXTFLT/REF	8 = START/DIR/Select REF/f-Fix1/REF
4 = FWD/UP/Select REF/f-Fix1/DOWN	9 = START/DIR/EXTFLT/REF

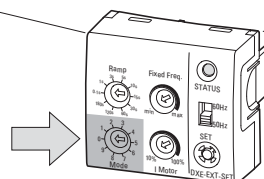


Figure 67: DXE-EXT-SET configuration module



The optional DXE-EXT-SET configuration module can only be used if parameter P-12 is set to 0. If it is, the control terminals' function (P-15) can be configured using the "Mode" selector switch.

The acronyms and abbreviations used for the control terminals' function are defined below:

Table 25: Function of the control terminals

Configuration	Description																									
FWD, REV	<ul style="list-style-type: none"> Operating direction selection (= enable signal and start command): <ul style="list-style-type: none"> FWD = clockwise rotating field at DI1 REV = counterclockwise rotating field at DI2 XOR interlock (exclusive or). If both operating directions are selected (HIGH level), the drive will be switched off. 																									
f-Fix1	<ul style="list-style-type: none"> Fixed frequency FF1 (20 Hz = P-20) If activated (HIGH level), the analog reference value signal (f-REF) will be ignored. 																									
f-Ref	<ul style="list-style-type: none"> Analog 0 - +10 V frequency reference value at AI1/DI4 (reference potential: 0 V) Signal range (P-16) Setting range from f-min (P-02) to f-max (P-01) 																									
EXTFLT	<ul style="list-style-type: none"> External fault message at DI3 Switches off the DE1... variable speed starter if there is no signal (LOW level). Input for a digital signal or thermistor 																									
Select f-Fix Bit0, Select f-Fix Bit1,	<p>Binary-coded selection (HIGH level) of fixed frequencies: f₂ = DE1... variable speed starter output frequency</p> <table border="1"> <thead> <tr> <th>Fixed frequency</th> <th>Select f-Fix Bit0</th> <th>Select f-Fix Bit1</th> <th>f₂</th> <th>Parameter</th> </tr> </thead> <tbody> <tr> <td>f-Fix1</td> <td>L</td> <td>L</td> <td>20 Hz</td> <td>P-20</td> </tr> <tr> <td>f-Fix2</td> <td>H</td> <td>L</td> <td>30 Hz</td> <td>P-21</td> </tr> <tr> <td>f-Fix3</td> <td>L</td> <td>H</td> <td>40 Hz</td> <td>P-22</td> </tr> <tr> <td>f-Fix4</td> <td>H</td> <td>H</td> <td>50 Hz</td> <td>P-23</td> </tr> </tbody> </table>	Fixed frequency	Select f-Fix Bit0	Select f-Fix Bit1	f ₂	Parameter	f-Fix1	L	L	20 Hz	P-20	f-Fix2	H	L	30 Hz	P-21	f-Fix3	L	H	40 Hz	P-22	f-Fix4	H	H	50 Hz	P-23
Fixed frequency	Select f-Fix Bit0	Select f-Fix Bit1	f ₂	Parameter																						
f-Fix1	L	L	20 Hz	P-20																						
f-Fix2	H	L	30 Hz	P-21																						
f-Fix3	L	H	40 Hz	P-22																						
f-Fix4	H	H	50 Hz	P-23																						
UP, DOWN	Digital frequency reference value within a range of f-min (P-02) to f-max (P-01). Controlled (HIGH level) with UP = increase and DOWN = lower.																									
START, DIR	START = Enable signal (HIGH level) at DI1 and start command with the operating direction preselected with DI2 (= DIR): HIGH = counterclockwise rotating field, LOW = clockwise rotating field																									
ENA	Activating the variable speed starter A start signal (START, FWD, REV) is also required for starting. If ENA is removed, the drive will coast.																									
MOR	Manual Activation If the MOR setting is active, the drive ignores field bus control and switches to terminal mode.																									

6 Parameter

6.5 Parameter description

Table 26: Parameters for configuring the control terminals

Panel Code	Modbus ID	Access right		Name	Value	DS	Description																																																							
		RUN, STOP	ro/rw																																																											
P-12	140	RUN	rw	ProcessData-Access	0, 1, ... ,13	0	<p>Process data access Control and reference value channel: 0: Control terminals (see P-15) 1: Keypad (control, setpoint value) for one operating direction. 2: Keypad (control, setpoint value) for two operating directions. 3: Modbus RTU (control, setpoint value) 9: SmartWire-DT (control, setpoint value) 10: SmartWire-DT (control), setpoint value via control terminals. 11: SmartWire-DT (control, setpoint value), enable signal with DI1, external fault message at DI3. 12: not permissible 13: SmartWire-DT (control, setpoint value), reference value set via control terminals. Note: Regardless of the selected control channel, an enable signal is always required at DI1 or DI2.</p> <p>in DE11 only 4: CANopen: internal ramp time 5: CANopen: CANopen ramp time</p>																																																							
Extended parameter range (access code: P-14 = 101 in default settings)																																																														
P-15	143	STOP	rw	DI Configuration Selection	0, 1, ... ,9	0	<p>Function of the control terminals When P-12 = 0, control signal terminals DI1 to DI4 can be configured with the following functions:</p> <table border="1"> <thead> <tr> <th>Mode</th> <th>DI1</th> <th>DI2</th> <th>DI3</th> <th>AI1/DI4</th> </tr> </thead> <tbody> <tr> <td>0</td> <td>FWD</td> <td>REV</td> <td>Select REF/f-Fix1</td> <td>REF</td> </tr> <tr> <td>1</td> <td>FWD</td> <td>REV</td> <td>EXTFLT</td> <td>REF</td> </tr> <tr> <td>2</td> <td>FWD</td> <td>REV</td> <td>Select f-Fix Bit0</td> <td>Select f-Fix Bit1</td> </tr> <tr> <td>3</td> <td>FWD</td> <td>Select REF/f-Fix1</td> <td>EXTFLT</td> <td>REF</td> </tr> <tr> <td>4</td> <td>FWD</td> <td>UP</td> <td>Select REF/f-Fix1</td> <td>DOWN</td> </tr> <tr> <td>5</td> <td>FWD</td> <td>UP</td> <td>EXTFLT</td> <td>DOWN</td> </tr> <tr> <td>6</td> <td>FWD</td> <td>REV</td> <td>UP</td> <td>DOWN</td> </tr> <tr> <td>7</td> <td>FWD</td> <td>Select f-Fix Bit0</td> <td>EXTFLT</td> <td>Select f-Fix Bit1</td> </tr> <tr> <td>8</td> <td>START</td> <td>DIR</td> <td>Select REF/f-Fix1</td> <td>REF</td> </tr> <tr> <td>9</td> <td>START</td> <td>DIR</td> <td>EXTFLT</td> <td>REF</td> </tr> </tbody> </table> <p>Note: The assigned control signal terminal functions will depend on the value set in P-12.</p>	Mode	DI1	DI2	DI3	AI1/DI4	0	FWD	REV	Select REF/f-Fix1	REF	1	FWD	REV	EXTFLT	REF	2	FWD	REV	Select f-Fix Bit0	Select f-Fix Bit1	3	FWD	Select REF/f-Fix1	EXTFLT	REF	4	FWD	UP	Select REF/f-Fix1	DOWN	5	FWD	UP	EXTFLT	DOWN	6	FWD	REV	UP	DOWN	7	FWD	Select f-Fix Bit0	EXTFLT	Select f-Fix Bit1	8	START	DIR	Select REF/f-Fix1	REF	9	START	DIR	EXTFLT	REF
Mode	DI1	DI2	DI3	AI1/DI4																																																										
0	FWD	REV	Select REF/f-Fix1	REF																																																										
1	FWD	REV	EXTFLT	REF																																																										
2	FWD	REV	Select f-Fix Bit0	Select f-Fix Bit1																																																										
3	FWD	Select REF/f-Fix1	EXTFLT	REF																																																										
4	FWD	UP	Select REF/f-Fix1	DOWN																																																										
5	FWD	UP	EXTFLT	DOWN																																																										
6	FWD	REV	UP	DOWN																																																										
7	FWD	Select f-Fix Bit0	EXTFLT	Select f-Fix Bit1																																																										
8	START	DIR	Select REF/f-Fix1	REF																																																										
9	START	DIR	EXTFLT	REF																																																										

6.5.6.1 Control terminal and keypad

When the device is used together with an optional external keypad (DXE-KEY-LED2), the START and STOP buttons can be used to start and stop the drive, and the speed and frequency reference value can be adjusted with the two arrow keys.



By default, the digital frequency reference value set with the keypad will not be stored. It will be automatically reset to zero with every stop command, → section 6.5.6.3, “Digital reference value reset mode”, page 108.

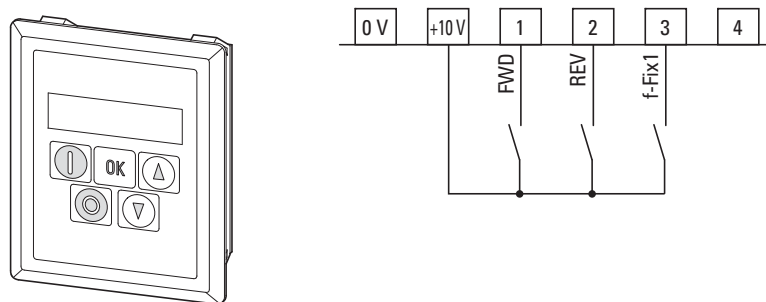


Figure 68: Optional DXE-KEY-LED2 keypad and control terminals with P-15 = 0 (default setting, mode 0)

P-12 = 1 (one operating direction)

Pressing the START button will start the drive in the operating direction specified using control terminals DI1 (FWD) and DI2 (REV).

P-12 = 2 (two operating directions)

Pressing the START button will start the drive in the operating direction specified using control terminals DI1 (FWD) and DI2 (REV). Pressing the START button again will automatically reverse the operating direction.

6 Parameter

6.5 Parameter description

In both settings (P-12 = 1, P-12 = 2), the control terminals can be configured with P-15 as follows:

Table 27: Configuration with external keypad

P-15 (Mode)	DI1	DI2	DI3	AI1/DI4
0	FWD	REV	f-Fix1	n. F. REF – at DE11
1	FWD	REV	EXTFLT	n. F. REF – at DE11
2	FWD	REV	Select f-Fix Bit0	Select f-Fix Bit1
3	FWD	f-Fix1	EXTFLT	n. F. REF – at DE11
4	FWD	UP	f-Fix1	DOWN
5	FWD	UP	EXTFLT	DOWN
6	FWD	REV	UP	DOWN
7	FWD	Select f-Fix Bit0	EXTFLT	Select f-Fix Bit1
8	START	DIR	f-Fix1	n. F. REF – at DE11
9	START	DIR	EXTFLT	n. F. REF – at DE11

n. F. = no function.

When configured this way, the control terminal will have no function!

P-12 = 3 (Modbus RTU)

Table 28: Configuration control terminals

P-15	DI1	DI2	DI3	DI4
0 ¹⁾	ENA	ENADIR	f-Fix1	MOR
1	ENA	ENADIR	EXTFLT	n. F.
2 ²⁾	ENA	ENADIR	Bit0	Select f-Fix Bit1
3 ³⁾	ENA	FF1	EXTFLT	n. F.
4 ²⁾	ENA	UP	f-Fix1	DOWN
5 ²⁾	ENA	UP	EXTFLT	DOWN
6 ²⁾	ENA	ENADIR	UP	DOWN
7 ²⁾	ENA	Bit0	EXTFLT	Bit1
8 ¹⁾	ENA	DIR	f-Fix1	n. F.
9	ENA	DIR	EXTFLT	n. F.

1) Setpoint values sent via Modbus will be ignored if DI3 is active.

2) P-15 = 4, 5 or 6 requires an activation signal (start command) via Modbus and at DI1. The digital setpoint values via Modbus are ignored in this case. It will only be possible to use UP and DOWN to set a setpoint value.

3) Setpoint values sent via Modbus will be ignored if DI2 is active.

n. F. = no function.

When configured this way, the control terminal will have no function!



If Modbus RTU is being used, there must always be an activation signal (ENA) present at DI1 control signal terminal (or DI2 = ENADIR) before the activation signal sent via Modbus RTU will be accepted.

The activated operating direction will depend on the digital input being driven (DI1, DI2) and on the value in command word ID1, bit 1.

Tabelle 29: Operating direction

DI1 (ENA)	DI2 (ENADIR)	Modbus RTU command word (ID1)		Operating direction (motor)
H = FWD	L	Bit0 = 1	Bit1 = 0 (FWD) →	FWD
L	H = REV	Bit0 = 1	Bit1 = 0 (FWD) →	REV
H = FWD	L	Bit0 = 1	Bit1 = 1 (REV) →	REV
L	H = REV	Bit0 = 1	Bit1 = 1 (REV) →	FWD

P-12 = 4: CANopen

Tabelle 30: Configuration control terminals

P-15	DI1	DI2	DI3	DI4
0	ENA	ENADIR	f-Fix1	n. F.
1	ENA	ENADIR	EXTFLT	n. F.
2	ENA	ENADIR	Bit0	Select f-Fix Bit1
3	ENA	f-Fix1	EXTFLT	n. F.
4 ¹⁾	ENA	UP	f-Fix1	DOWN
5 ¹⁾	ENA	UP	EXTFLT	DOWN
6 ¹⁾	ENA	ENADIR	UP	DOWN
7	ENA	Bit0	EXTFLT	Bit1
8	ENA	DIR	f-Fix1	n. F.
9	ENA	DIR	EXTFLT	n. F.

1) P-15 = 4, 5 or 6 requires an activation signal (start command) via CANopen and at DI1. The digital nominal values via CANopen are ignored in this case. It will only be possible to use UP and DOWN to set a setpoint value.

n. F. = no Function.

When configured this way, the control terminal will have no function!



If CANopen is being used, there must always be an activation signal (ENA) present at DI1 control signal terminal (or DI2 = ENADIR) before the activation signal sent via CANopen will be accepted.

6 Parameter

6.5 Parameter description

6.5.6.2 SmartWire-DT

When the device is used together with SmartWire-DT, the control terminals can be configured as shown below by using parameter P-15.



Process data access via SmartWire-DT (P-12 = 9, 10, 11, 13) requires a SmartWire-DT DX-NET-SWD3 module.



For more information and technical data on SmartWire-DT and the DX-NET-SWD3 interface module, please refer to manual MN04012009Z.

P-12 = 9 (SWD control + SWD setpoint value)

P-12 = 11 (local control + SWD setpoint value), enable signal with DI1, external fault message at DI3.

Table 31: Configuration with SmartWire-DT and P-12 (= 9, 11)

P-15 (Mode)	DI1	DI2	DI3	AI1/DI4
0	ENA	n. F.	n. F.	n. F.
1	ENA	n. F.	EXTFLT	n. F.
2	ENA	n. F.	n. F.	n. F.
3	ENA	n. F.	EXTFLT	n. F.
4	ENA	n. F.	n. F.	n. F.
5	ENA	n. F.	EXTFLT	n. F.
6	ENA	n. F.	n. F.	n. F.
7	ENA	n. F.	EXTFLT	n. F.
8	ENA	n. F.	n. F.	n. F.
9	ENA	n. F.	EXTFLT	n. F.

n. F. = no Function

When configured this way, the control terminals "n. F." will have no function whatsoever!

P-12 = 10 (SWD control), setpoint value via control terminals

Table 32: Configuration with SmartWire-DT and P-12 (= 10)

P-15 (Mode)	DI1	DI2	DI3	A11/DI4
0	ENA	n. F.	f-Fix1	f-REF
1	ENA	n. F.	EXTFLT	f-REF
2	ENA	P-01	Select f-Fix Bit0	Select f-Fix Bit1
3	ENA	f-Fix1	EXTFLT	f-REF
4	ENA	UP	f-Fix1	DOWN
5	ENA	UP	EXTFLT	DOWN
6	ENA	n. F.	UP	DOWN
7	ENA	Select f-Fix Bit0	EXTFLT	Select f-Fix Bit1
8	ENA	n. F.	f-Fix1	f-REF
9	ENA	n. F.	EXTFLT	f-REF

n. F. = no Function

When configured this way, the control terminals "n. F." will have no function whatsoever!

P-01 =maximum output frequency

P-12 = 13 (SWD control + SWD setpoint value), reference value enable signal via control terminals.

Table 33: Configuration with SWD and P-12 (= 13)

P-15 (Mode)	DI1	DI2	DI3	A11/DI4
0	FWD	REV	f-Fix1	f-REF
1	FWD	REV	EXTFLT	f-REF
2	FWD	REV	Select f-Fix Bit0	Select f-Fix Bit1
3	FWD	f-Fix1	EXTFLT	f-REF
4	FWD	UP	f-Fix1	DOWN
5	FWD	UP	EXTFLT	DOWN
6	FWD	REV	UP	DOWN
7	FWD	Select f-Fix Bit0	EXTFLT	Select f-Fix Bit1
8	START	DIR	f-Fix1	f-REF
9	START	DIR	EXTFLT	f-REF

6 Parameter

6.5 Parameter description

6.5.6.3 Digital reference value reset mode

Table 34: Parameter P-24

Panel Code	Access right		Name	Value	DS	Description
	RUN, STOP	ro/rw				
P-24	RUN	rw	Digital Reference Reset Mode	0, 1, 2, 3	0	Defines the behavior of the drive on START when used in Keypad control or when controlled with UP/DOWN commands via terminals. 0: Start at min speed 1: Start with latest speed before switching off 2: Start at min speed (Auto-r) 3: Start with latest speed before switching off (Auto-r) Auto r: START and STOP button on the keypad are disabled. DE1 starts with a START command at the terminals.

When P-12 = 0 (control commands via terminals) and P-15 = 4, 5, or 6, the frequency reference value can be set digitally (UP/DOWN). This digital reference will always be automatically reset to 0 Hz (P-24 = 0) whenever the mains voltage is disconnected, as well as every time after a stop command. The device will then restart with the value in parameter P-02 (f-min).

By setting P-24 to 1, this reset function can be disabled. In this case, the last reference value that is set will be stored before the device is switched off and will automatically be used when the device is restarted. The time set in P-03 (t-acc) will be used for the acceleration ramp.

If P-12 = 1 (or = 2), the optional DX-KEY-LED2 keypad can be used to control the device and set its reference values, provided there is an enable signal at a digital input (DI1 or DI2). The digital reference will always be automatically reset to 0 Hz (P-24 = 0) whenever the mains voltage is disconnected, as well as every time after a stop command, in this configuration as well. The device will then restart with the value in parameter P-02 (f-min). Setting P-24 to 1 will disable the reset function in this case as well.

An additional option is to set parameter P-24 to a value of 2 or 3. In this case, the keypad's START and STOP buttons will be disabled. The DE1... variable speed starter will then respond only to commands applied to control terminals' start and stop commands. However, it will still be possible to use the two arrow keys on the keypad in order to digitally set the frequency reference value.

6.5.6.4 Analog input (AI1/DI4)

By default, control terminal 4 will be configured as analog input AI1 (0 - +10 V). The corresponding signal common is terminal 0 V.

The signal range for this analog input can be configured using P-16:

0 = 0 - 10 V (default settings)

1 = 0 - 20 mA

2 = 4 - 20 mA (t 4 - 20 mA); if there is a wire breakage, the drive will be switched off and a fault message will be sent

3 = 4 - 20 mA (r 4 - 20 mA); if there is a wire breakage, the drive will use the set ramp time (P-04) to change the frequency to fixed frequency FF1 (P-20; default setting = 20 Hz).

P-17 can be used to scale analog input AI1's input signal.

Example

P-01 = 50 Hz, f-REF = 0 - 10 V

P-17 = 1.000: (0 - +10 V) × 1 → 0 - 50 Hz

At a reference voltage of 10 V, the output frequency will reach the value in P-01 (100 %).

P-17 = 0.100: (0 - +10 V) × 0.1 → 0 - 5 Hz

At 10 V, the output frequency will reach a value of 10 % of P-01.

Note:

Higher reference voltages (> 10 V) are not permissible!

P-17 = 2.000: (0 - +5 (10) V) × 2 → 0 - 50 (50) Hz

At 5 V, the output frequency will reach the value in P-01, and will then remain constant within a range > 5 - 10 V (gain factor: 200 %).

P-17 = 2.500: (0 - +4 (10) V) × 2.5 → 0 - 50 (50) Hz,

At 4 V, the output frequency will reach the value in P-01, and will then remain constant within a range > 4 - 10 V (gain factor: 250 %).

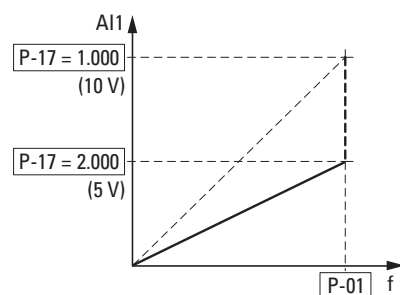


Figure 69: Scaled reference value input

6 Parameter

6.5 Parameter description

Inverting analog input AI1

Parameter P-18 can be used to configure analog input AI1 for applications with an inverted reference voltage (f-max at 0 V, f-min at 10 V):

- 0: 0 V = f-min (P-02)
 10 V = f-max (P-01)
- 1: 0 V = f-max (P-01)
 10 V = f-min (P-02)

Table 35: Parameter P-16, P-17, P-18

Panel Code	Modbus ID	Access right		Name	Value	DS	Description
		RUN, STOP	ro/rw				
P-16	144	STOP	rw	AI1 Signal Range	0, 1, 2, 3	0	Configures the Analog input 1 for the selected signal source type. 0 - 10 V 0 - 20 mA t 4 - 20 mA (Trip in case of wire break) r 4 - 20 mA (Ramps to f-fix1 (P-20) in case of wire break)
P-17	145	RUN	rw	AI1 Gain	0.10 - 2,500	1,000	Scaling of the Analog Input 1 Output value = Input value * Scaling. Example: P-16 = 0 - 10 V, P-17 = 2.000: at 5 V the motor turns with max speed (P-01) (5 V * 2 = 10 V)
P-18	146	STOP	rw	AI1 Invert	0/1	0	Setting this parameter to 1 inverts the logic of the analog input. 0: 0 V / 0(4) mA = min frequency, 10 V / 20 mA = max frequency 1: 0 V / 0(4) mA = max frequency, 10 V / 20 mA = min frequency

6.6 Parameter lock

The DE1... variable speed starter's parameters can be protected from misuse. This function can be used to ensure that only authorized people will be able to make changes to the parameters. To block access to all parameters, set P-39 to 1 (ro = read only).

Exception: Parameter P-14 will always be accessible. The access source for the parameter is defined in P-41.

By default, only the "basic parameters" (P-01 through P-14) will be accessible and editable. To access all parameters, code 101 (default code) needs to be entered in parameter P-14. This access code can be changed in parameter P-38.

The following example shows the steps required in order to lock the device's parameters (provided the corresponding default settings are still being used). It is important to follow the steps in the specified order:

1. P-14 = 101 Default access code used to access all parameters (makes it possible to select P-39).
2. P-38 = 123 New access code (example).
3. P-14 = 123 Test: The new code unlocks access to all parameters.
4. P-39 = 1 Parameter lock. All parameters will be switched to read-only status. It will not be possible to enter values for any parameter (with the exception of P-39). The DX-KEY-LED2 keypad's display will show an L ("Lock") in its left segment.
5. P-14 **Note:**
Parameter P-14 will still be showing the new access code (123).
6. P-14 ≠ 123 A value other than 123 needs to be entered for parameter P-14! After this value is entered, only parameters P-01 through P-14 will continue to be accessible. All other parameters will remain inaccessible until the new access code (123) is entered. After doing so, the parameter lock can be unlocked by setting P-39 to 0.



With the exception of password P-38, locked parameter sets can be read with a computer ("drivesConnect" parameter configuration software) or with a keypad (DX-KEY-...) (read-only).

Locked parameter sets can be copied to a DE1... variable speed starter with a computer ("drivesConnect" parameter configuration software) or a DX-COM-STICK3, provided the parameter set is not locked in the DE1... variable speed starter.

6 Parameter

6.7 Default settings

Table 36: Parameter Lock

Panel Code	Modbus ID	Access right		Name	Value	DS	Description
		RUN, STOP	ro/rw				
P-14	142	RUN	rw	Password	0 - 65535	0	Entry of the password to get access to the extended parameter set. The value to be put in is determined by P-38 (default: 101). Extended parameters are accessible.
P-38	166	RUN	rw	Password Level 2	0 - 9999	101	Defines the password which is used to get access to extended parameter set (Level 2). Access via P-14.
P-39	167	RUN	rw	Parameter Lock	0; 1	0	Determines whether to lock the parameters 0: OFF. All parameters can be accessed and changed 1: ON. Parameter values can be displayed, but cannot be changed. If a remote keypad is connected, parameters cannot be accessed by the remote keypad if they are locked.
P-41	169	RUN	rw	ParameterAccess	0; 1	0	Parameter Access 0: All parameters can be changed by any source. 1: All parameters locked; can only be changed by the SWD Device.

6.7 Default settings



Setting P-37 to 1 (the DX-KEY-LED2 display will show *P-def*) will reset all parameters to their default settings. The fault memory (P-13) and the monitor memory (P00-...) will not be reset!

Table 37: Default settings (P-37)

Panel Code	Modbus ID	Access right		Name	Value	DS	Description
		RUN, STOP	ro/rw				
P-37	165	STOP	rw	Parameter Set	0; 1	0	Restores factory parameter settings. 0: deactivated 1: Restore factory settings

6.8 Displaying operational data

The variable speed starter's operational data can be displayed using the extended parameter set (P-14 = 101, → page 84):

- External DX-KEY-LED2 keypad: Press the OK button while viewing parameter P00.
- drivesConnect parameter configuration software:
Open the "Monitor" directory.

The measured and calculated operational data will be listed as P00-01 to P00-20. When using a DX-KEY-LED2 keypad, the operational data shown can be selected using the ▲ and ▼ and the OK button. Once the OK button is pressed, the current parameter will be shown constantly ("set display value"). In order to access a different indicator value, you will need to press the OK button again.



Operational data values cannot be changed manually (i.e., by entering values by hand).



The display/monitoring parameters are listed on → page 164.

6 Parameter

6.8 Displaying operational data

Example: Status displays

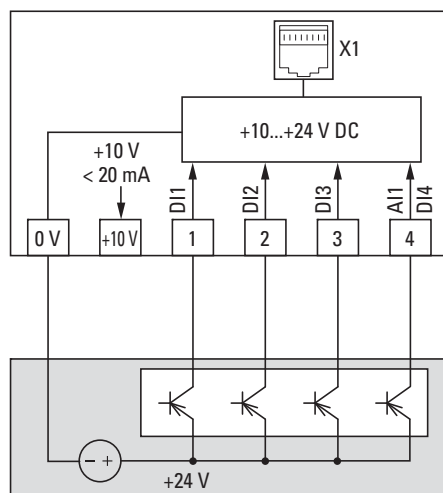


Figure 70: Example with external PLC

The status of the digital inputs will be represented as single bits (0000 = DI1, DI2, DI3, DI4). They can be used to monitor whether a control signal (e.g., from an external PLC) activates the variable speed starter's inputs (DI1 - DI4). This is an easy way to check wiring (wire breakage). Following are a few examples:

Panel Code	ID	Display value	Description
P0-04	11	0000	No digital input (DI1, DI2, DI3, DI4) is actuated
		1000	Control signal on terminal 1 active (DI1)
		0100	Control signal on terminal 2 active (DI2)
		0010	Control signal on terminal 3 active (DI3)
		0001	Control signal on terminal 4 active (DI4)
		0101	Control signal on terminal 2 and terminal 4 active (DI2 + DI4)

Display value: 1 = Activated = High; 0 = Not activated = Low

7 Modbus RTU und CANopen bus systems

7.1 Modbus RTU



For detailed information on Modbus RTU bus system in connection with DE1... variable speed starters, please refer to the separate manual:

MN040018: "Modbus RTU – Communication manual for DA1, DC1, DE1 variable frequency drives"



For more information on Modbus, please visit:
www.modbus.org

7.2 CANopen



CANopen bus system can only be used with DE**11** variable speed starters!

For detailed information, please refer to the separate manual:

MN040019: "CANopen – Communication manual for DA1, DC1, DE11 variable frequency drives"



For more information on CANopen, please visit:
www.can-cia.org

7 Modbus RTU und CANopen bus systems

7.2 CANopen

8 Technical Data

The following tables show the performance characteristics for the various DE1... variable speed starter models together with the motor power that are compatible with them.



The motor power allocation is based on the rated operational current.



The motor power is the mechanical power at the shaft of a normal, four pole, internally or externally ventilated alternating current asynchronous motor with 1.500 rpm at 50 Hz or 1.800 rpm at 60 Hz.

8.1 Features

Part no.	Rated operational current I_e A	Frame size FS	Degree of protection IP	Assigned motor power	
				P (230 V, 50 Hz) kW	P (220 - 240 V, 60 Hz) HP
Mains supply voltage: 1 AC 230 V (200 - 240 V ± 10 %), 50/60 Hz,					
Output voltage: 3 AC 230 V (200 - 240 V ± 10 %), 50/60 Hz					
DE1...-121D4...	1.4	FS1	IP20	0.25	1/3
DE1...-122D3...	2.3	FS1	IP20	0.37	1/2
DE1...-122D7...	2.7	FS1	IP20	0.55	1/2
DE1...-124D3...	4.3	FS1	IP20	0.75	1
DE1...-127D0...	7	FS1	IP20	1.5	2
DE1...-129D6...	9.6	FS2	IP20	2.2	3

1) The rated motor currents apply to normal internally and surface-cooled three-phase motors.

Part no.	Rated operational current I_e A	Frame size FS	Degree of protection IP	Assigned motor power	
				P (400 V, 50 Hz) kW	P (440 - 480 V, 60 Hz) HP
Mains supply voltage: 3 AC 400 V, 50 Hz/480 V, 60 Hz (380 V - 480 V ± 10 %)					
Output voltage: 3 AC 400 V, 50 Hz/480 V, 60 Hz (380 V - 480 V ± 10 %)					
DE1...-341D3...	1.3	FS1	IP20	0.37	1/2
DE1...-342D1...	2.1	FS1	IP20	0.75	1
DE1...-343D6...	3.6	FS1	IP20	1.5	2
DE1...-345D0...	5	FS2	IP20	2.2	3
DE1...-346D6...	6.6	FS2	IP20	3	3
DE1...-348D5...	8.5	FS2	IP20	4	5
DE1-34011...	11.3	FS2	IP20	5.5	7.5
DE1-34016...	16	FS2	IP20	7.5	10

1) The rated motor currents apply to normal internally and surface-cooled three-phase motors

8 Technical Data

8.2 General rating data

8.2 General rating data

	Symbol	Unit	Value
Standards			Specification for general requirements: IEC/EN 61800-2 EMC requirements: IEC/EN 61800-3; Safety requirements: IEC/EN 61800-5-1
Certifications and manufacturer's declarations on conformity			CE, UL, cUL, RCM
Production quality			RoHS, ISO 9001
Climatic proofing	ρ_w	%	< 95%, average relative humidity (RH), non-condensing, non-corrosive, no dripping water (IEC/EN 61800-5-1) < 95%, average relative humidity (RH), non-condensing, non-corrosive, no dripping water (IEC/EN 61800-5-1)
Ambient temperature			
Operation			
IP20 (NEMA 0)	θ	°C	-10 - +60 Exception: The following device types use derating: DE1...-34016NN-N20N DE1...-34016FN-N20N.
Storage	θ	°C	-40 - +70
Impact resistance (EN 60068-2-27)			15 g/11 ms (under operating conditions) <ul style="list-style-type: none"> • Mounted on DIN-rail • Mounted on mounting plate with screws
Vibration as per IEC/EN 61800-5-1			Transportation as per IEC/EN 61800-2 DE1... transported as a single device in a separate package and UPS drop test (15 g/11 ms)
MTBF (mean time between failures)			DE1...-12... (FS1): > 73 years DE1...-12... (FS2): > 17 years DE1...-34... (FS1): > 88 years DE1...-34... (FS2): > 73 years
Electrostatic discharge (ESD, IEC 61800-3)	U	kV	±4, contact discharge / ±6, air discharge
Fast transient Burst (IEC 61800-3)			5 kHz for 5 min. / 100 kHz for 5 min.
Radio interference class (EN 61800-3)			
Maximum motor cable length (screened) with integrated radio interference suppression filter			
C1 (only at DE1...-12..., for conducted emissions only)		m	5
C2	l	m	10
C3	l	m	25
Interference immunity (EN 61800-3)			1st and 2nd environments
Maximum motor cable length			
not screened	l	m	125
screened	l	m	65
Mounting position			Any, not suspended (front not facing downwards); vertical only with DE1...-121D4..., DE1-122D3..., DE1-122D7... devices
Altitude	h	m	0 - 1000 above sea level, > 1,000 with 1 % load current reduction (derating) for every 100 m, Max. 2000
Degree of protection			IP20 (NEMA 0)
Protection against contact			BGV A3 (VBG4, finger- and back-of-hand proof)

8.3 Rating data

8.3.1 DE1...-12... (single-phase mains connection)

	Sym- bol	Unit	DE1...- 121D4...	DE1...- 122D3...	DE1...- 122D7...	DE1...- 124D3...	DE1...- 127D0...	DE1...- 129D6...
Mains connection								
Rated operational voltage	U_e	V	230, single-phase	230, single-phase	230, single-phase	230, single-phase	230, single-phase	230, single-phase
Mains voltage	U_{LN}	V	200 - 240 $\pm 10\%$ (180 - 264)	200 - 240 $\pm 10\%$ (180 - 264)	200 - 240 $\pm 10\%$ (180 - 264)	200 - 240 $\pm 10\%$ (180 - 264)	200 - 240 $\pm 10\%$ (180 - 264)	200 - 240 $\pm 10\%$ (180 - 264)
Mains frequency	f	Hz	50/60 $\pm 10\%$	50/60 $\pm 10\%$	50/60 $\pm 10\%$	50/60 $\pm 10\%$	50/60 $\pm 10\%$	50/60 $\pm 10\%$
Input current (without mains choke)	I_{LN}	A	3.6	6.2	7.3	11.3	17.4	23.2
Power section								
Rated operational current	I_e	A	1.4	2.3	2.7	4.3	7	9.6
Overload current, 1.5 x I_e , cyclically for 60 s every 600 s	I_{2-150}	A	2.1	3.45	4.05	6.45	10.5	14.4
Overload current, max. 2 x I_e every 600 s	I_{2max}	A	2.8	4.6	5.4	8.6	14	19.2
Output voltage at U_e	U_2	V	230, 3-phase	230, 3-phase	230, 3-phase	230, 3-phase	230, 3-phase	230, 3-phase
Output frequency	f_2	Hz	0 - 50/60 (max. 300)	0 - 50/60 (max. 300)	0 - 50/60 (max. 300)	0 - 50/60 (max. 300)	0 - 50/60 (max. 300)	0 - 50/60 (max. 300)
Frequency resolution (reference value)	Δf	%	0.025	0.025	0.025	0.025	0.025	0.025
Pulse frequency (audible)	f_{PWM}	kHz	16 (4/8/12/16/ 24/32)	16 (4/8/12/16/ 24/32)	16 (4/8/12/16/ 24/32)	16 (4/8/12/16/ 24/32)	16 (4/8/12/16/ 24/32)	16 (4/8/12/16/ 24/32)
Output reduction between 50 °C and 60 °C			None	None	None	None	None	None
Contact current ¹⁾	I_{PE}	mA	< 3.5 AC/ < 10 DC	< 3.5 AC/ < 10 DC	< 3.5 AC/ < 10 DC	< 3.5 AC/ < 10 DC	< 3.5 AC/ < 10 DC	< 3.5 AC/ < 10 DC
DC braking			0 - 100 % U_e , 0 - 10 s, parameterizable					

1) With single-phase devices, DE1...-12, depending on the design a higher leakage current will be produced if the lines at L1 and N are swapped.

8 Technical Data

8.3 Rating data

	Sym- bol	Unit	DE1...- 121D4...	DE1...- 122D3...	DE1...- 122D7...	DE1...- 124D3...	DE1...- 127D0...	DE1...- 129D6...
Heat dissipation (idle, standby)	P _V	W	3.44	3.44	3.44	3.44	3.44	4.66
Heat dissipation (speed/torque)								
100/100	P _V	W	16,4	18,3	25	30,9	78,4	91
90/100	P _V	W	16,4	18,3	25	30,9	78,4	91
90/50	P _V	W	12,6	10,4	15,1	15,3	51,6	55
50/100	P _V	W	13,5	16,8	19,8	28,9	68,9	72
50/50	P _V	W	11,6	7,9	12,3	14,7	44,9	46
50/25	P _V	W	10,9	5,6	10	10,3	37	38
0/100	P _V	W	13	–	25,3	31,8	62,4	–
0/50	P _V	W	10,5	10	10,9	15,2	44,6	–
0/25	P _V	W	–	–	–	–	–	30

Motor feeder

Motor power, assigned

at 230 V, 50 Hz	P	kW	0.25	0.37	0.55	0.75	1.5	2.2
at 220 -240 V, 60 Hz	P	HP	1/3	1/2	1/2	1	2	3

Apparent power at rated value

at 230 V	S	kVA	0.56	0.92	1.08	1.71	2.79	3.82
at 240 V	S	kVA	0.58	0.96	1.12	1.79	2.91	3.99

	Sym- bol	Unit	DE1...- 121D4...	DE1...- 122D3...	DE1...- 122D7...	DE1...- 124D3...	DE1...- 127D0...	DE1...- 129D6...
Control section								
Relay								
Contact			S (RUN signal)					
Voltage, maximum	U	V	250 AC/30 DC	250 AC/30 DC	250 AC/30 DC	250 AC/30 DC	250 AC/30 DC	250 AC/30 DC
Load current, maximum	I	A	6 AC-1/5 DC-1	6 AC-1/5 DC-1	6 AC-1/5 DC-1	6 AC-1/5 DC-1	6 AC-1/5 DC-1	6 AC-1/5 DC-1
Reference voltage/Control voltage								
Output voltage	U _c	V	10	10	10	10	10	10
Max. permissible load current	I _c	mA	20	20	20	20	20	20
Analog input								
Resolution			12-bits	12-bits	12-bits	12-bits	12-bits	12-bits
Voltage	U _s	V	0 - +10	0 - +10	0 - +10	0 - +10	0 - +10	0 - +10
Current	I _s	mA	0/4 - 20	0/4 - 20	0/4 - 20	0/4 - 20	0/4 - 20	0/4 - 20
Digital input								
High signal voltage level	U _c	V	9 - +30	9 - +30	9 - +30	9 - +30	9 - +30	9 - +30
Input current	I _s	mA	1.15 (10 V)/ 3 (24 V)	1.15 (10 V)/ 3 (24 V)	1.15 (10 V)/ 3 (24 V)	1.15 (10 V)/ 3 (24 V)	1.15 (10 V)/ 3 (24 V)	1.15 (10 V)/ 3 (24 V)
Enclosure								
Frame size			FS1	FS1	FS1	FS1	FS1	FS2
Dimensions (W x H x D)		mm	45 x 230 x 169	45 x 230 x 169	45 x 230 x 169	45 x 230 x 169	45 x 230 x 169	90 x 230 x 169
Maximum permissible deviation from vertical installation position		Degrees	5	5	5	90	90	90
Internal device fan			No	No	No	Yes	Yes	Yes
Degree of protection			IP20/NEMA 0	IP20/NEMA 0	IP20/NEMA 0	IP20/NEMA 0	IP20/NEMA 0	IP20/NEMA 0
Weight	m	kg	1.04	1.04	1.06	1.06	1.06	1.68

8 Technical Data

8.3 Rating data

	Sym- bol	Unit	DE1...- 121D4...	DE1...- 122D3...	DE1...- 122D7...	DE1...- 124D3...	DE1...- 127D0...	DE1...- 129D6...
Terminal capacities, clampable								
Power section								
Solid or stranded	A	mm ²	1 - 6	1 - 6	1 - 6	1 - 6	1 - 6	1 - 6
flexible with ferrule	A	mm ²	1 - 6	1 - 6	1 - 6	1 - 6	1 - 6	1 - 6
Solid or stranded	A	AWG	18 - 6	18 - 6	18 - 6	18 - 6	18 - 6	18 - 6
Strip length	l	mm	8	8	8	8	8	8
tool			PZ2 (Pozidrive) cross screwdriver					
Tightening torque	M	Nm	1.2	1.2	1.2	1.2	1.2	1.2
Control section								
Solid or stranded	A	mm ²	0.05 - 1.5	0.05 - 1.5	0.05 - 1.5	0.05 - 1.5	0.05 - 1.5	0.05 - 1.5
flexible with ferrule	A	mm ²	0.5 - 1	0.5 - 1	0.5 - 1	0.5 - 1	0.5 - 1	0.5 - 1
Solid or stranded	A	AWG	30 - 16	30 - 16	30 - 16	30 - 16	30 - 16	30 - 16
Strip length	l	mm	5	5	5	5	5	5
tool			0.7 x 3 mm standard screwdriver					
Tightening torque	M	Nm	0.5	0.5	0.5	0.5	0.5	0.5

8.3.2 DE1...-34... (three-phase mains connection)

	Symbol	Unit	DE1...-341D3...	DE1...-342D1...	DE1...-343D6...	DE1...-345D0...	
Mains connection							
Rated operational voltage	U_e	V	380/400/480, 3-phase	380/400/480, 3-phase	380/400/480, 3-phase	380/400/480, 3-phase	
Mains voltage	U_{LN}	V	380 - 480 \pm 10 % (342 - 528)	380 - 480 \pm 10 % (342 - 528)	380 - 480 \pm 10 % (342 - 528)	380 - 480 \pm 10 % (342 - 528)	
Mains frequency	f	Hz	50/60 \pm 10 %	50/60 \pm 10 %	50/60 \pm 10 %	50/60 \pm 10 %	
Input current (without mains choke)	I_{LN}	A	1.7	3.1	4.9	7	
Power section							
Rated operational current	I_e	A	1.3	2.1	3.6	5	
Overload current, 1.5 x I_e , cyclically for 60 s every 600 s	I_{2-150}	A	1.95	3.15	5.4	7.5	
Overload current, max. 2 x I_e every 600 s	I_{2max}	A	2.6	4.2	7.2	10	
Output voltage at U_e	U_2	V	380/400/480, 3-phase	380/400/480, 3-phase	380/400/480, 3-phase	380/400/480, 3-phase	
Output Frequency	f_2	Hz	0 - 50/60 (max. 300)	0 - 50/60 (max. 300)	0 - 50/60 (max. 300)	0 - 50/60 (max. 300)	
Frequency resolution (reference value)	Δf	%	0.025	0.025	0.025	0.025	
Pulse frequency (audible)	f_{PWM}	kHz	16 (10/12/14/16/ 18/20)	16 (10/12/14/16/ 18/20)	16 (10/12/14/16/ 18/20)	16 (10/12/14/16/ 18/20)	
Derating between 50 °C and 60 °C			None	<ul style="list-style-type: none"> None if $f_{PWM} \leq 16$ kHz None if $f_{PWM} \leq 20$ kHz, up to a max. of 57 °C None if $I_e \leq 1.6$ A 	<ul style="list-style-type: none"> None if $f_{PWM} \leq 16$ kHz None if $I_e \leq 3.2$ A None up to a max. of 57 °C 	None	
Contact current	I_{PE}	mA	< 3.5 AC / < 10 DC	< 3.5 AC / < 10 DC	< 3.5 AC / < 10 DC	< 3.5 AC / < 10 DC	
DC braking			0 - 100 % U_e , 0 - 10 s, parameterizable				
Heat dissipation (idle, standby)	P_V	W	5.13	5.13	5.13	5.52	
Heat dissipation (speed/torque)							
	100/100	P_V	W	16,7	26,8	44,9	57
	90/100	P_V	W	16,7	26,8	44,9	57
	90/50	P_V	W	14,2	16,7	30,4	39
	50/100	P_V	W	20,7	27,9	44,7	50
	50/50	P_V	W	11,4	17,2	28,4	37
	50/25	P_V	W	9,9	14,3	24,9	30
	0/100	P_V	W	–	–	41,6	–
	0/50	P_V	W	–	–	22,3	36
	0/25	P_V	W	–	–	–	29

8 Technical Data

8.3 Rating data

	Symbol	Unit	DE1...-341D3...	DE1...-342D1...	DE1...-343D6...	DE1...-345D0...
Motor feeder						
Motor power, assigned						
at 400 V, 50 Hz	P	kW	0.37	0.75	1.5	2.2
at 440 - 480 V, 60 Hz	P	HP	1/2	1	2	3
Apparent power at rated value						
at 400 V	S	kVA	0.90	1.45	2.49	3.46
at 480 V	S	kVA	1.08	1.75	2.99	4.16
Control section						
Relay						
Contact			S (RUN signal)			
Voltage, maximum	U	V	250 AC/30 DC	250 AC/30 DC	250 AC/30 DC	250 AC/30 DC
Load current, maximum	I	A	6 AC-1/5 DC-1	6 AC-1/5 DC-1	6 AC-1/5 DC-1	6 AC-1/5 DC-1
Reference voltage/Control voltage						
Output voltage	U _c	V	10	10	10	10
Maximum permissible load current	I _c	mA	20	20	20	20
Analog input						
Resolution			12 Bit	12 Bit	12 Bit	12 Bit
Voltage	U _s	V	0 - +10	0 - +10	0 - +10	0 - +10
Current	I _s	mA	0/4 - 20	0/4 - 20	0/4 - 20	0/4 - 20
Digital Input						
High signal voltage level	U _c	V	9 - +30	9 - +30	9 - +30	9 - +30
Input current	I _c	mA	1.15 (10 V)/ 3 (24 V)	1.15 (10 V)/ 3 (24 V)	1.15 (10 V)/ 3 (24 V)	1.15 (10 V)/ 3 (24 V)
Enclosure						
Frame size			FS1	FS1	FS1	FS2
Dimensions (W x H x D)		mm	45 x 230 x 169	45 x 230 x 169	45 x 230 x 169	90 x 230 x 169
Maximum permissible deviation from vertical installation position		Degrees	90	90	90	90
Internal device fan			Yes	Yes	Yes	Yes
Degree of protection			IP20/NEMA 0	IP20/NEMA 0	IP20/NEMA 0	IP20/NEMA 0
Weight	m	kg	1	1	1	1.6

	Symbol	Unit	DE1...-341D3...	DE1...-342D1...	DE1...-343D6...	DE1...-345D0...
Terminal capacities, clampable						
Power section						
Solid or stranded	A	mm ²	1 - 6	1 - 6	1 - 6	1 - 6
flexible with ferrule	A	mm ²	1 - 6	1 - 6	1 - 6	1 - 6
Solid or stranded	A	AWG	18 - 6	18 - 6	18 - 6	18 - 6
Strip length	l	mm	8	8	8	8
tool			PZ2 (Pozidrive) cross screwdriver			
Tightening Torque		Nm	1.2	1.2	1.2	1.2
Control section						
Solid or stranded	A	mm ²	0.05 - 1.5	0.05 - 1.5	0.05 - 1.5	0.05 - 1.5
flexible with ferrule	A	mm ²	0.5 - 1	0.5 - 1	0.5 - 1	0.5 - 1
Solid or stranded	A	AWG	30 - 16	30 - 16	30 - 16	30 - 16
Strip length	l	mm	5	5	5	5
tool			0.7 x 3 mm standard screwdriver			
Tightening Torque	M	Nm	0.5	0.5	0.5	0.5

8 Technical Data

8.3 Rating data

	Symbol	Unit	DE1...-346D6...	DE1...-348D5...	DE1...-34011...	DE1...-34016...	
Mains connection							
Rated operational voltage	U_e	V	380/400/480, 3-phase				
Mains voltage	U_{LN}	V	380 - 480 \pm 10 % (342 - 528)				
Mains frequency	f	Hz	50/60 \pm 10 %	50/60 \pm 10 %	50/60 \pm 10 %	50/60 \pm 10 %	
Input current (without mains choke)	I_{LN}	A	8.5	10	12	16.5	
Power section							
Rated operation current	I_e	A	6.6	8.5	11	16	
Overload current, 1.5 x I_e , cyclically for 60 s every 600 s	I_{2-150}	A	9.9	12.75	16.5	24	
Overload current, max. 2 x I_e every 600 s	I_{2max}	A	13.2	17	22	32	
Output voltage at U_e	U_2	V	380/480, 3-phase	380/480, 3-phase	380/480, 3-phase	380/480, 3-phase	
Output Frequency	f_2	Hz	0 - 50/60(max.300)	0 - 50/60(max.300)	0 - 50/60(max.300)	0 - 50/60(max.300)	
Frequency resolution (reference value)	Δf	%	0.025	0.025	0.025	0.025	
Pulse frequency (audible)	f_{PWM}	kHz	16 (10/12/14/16/18/20)	16 (10/12/14/16/18/20)	16 (10/12/14/16/18/20)	16 (10/12/14/16/18/20)	
Derating between 50 °C and 60 °C			None	None	<ul style="list-style-type: none"> None if $f_{PWM} \leq 16$ kHz None if $I_e \leq 10.6$ A and $f_{PWM} \leq 20$ kHz None up to a max. of 57 °C 	<ul style="list-style-type: none"> None if $f_{PWM} \leq 14$ kHz up to a max. of 50 °C None if $f_{PWM} \leq 16$ kHz up to a max. of 46 °C None if $I_e \leq 14.9$ A and $f_{PWM} \leq 10$ kHz None if $I_e \leq 10.6$ A and $f_{PWM} \leq 20$ kHz 	
Contact current	I_{PE}	mA	< 3.5 AC/< 10 DC	< 3.5 AC/< 10 DC	< 3.5 AC/< 10 DC	< 3.5 AC/< 10 DC	
DC braking			0 - 100 % U_e , 0 - 10 s, parameterizable				
Heat dissipation (idle, standby) P_v		W	5.52	5.52	5.52	5.52	
Heat dissipation (speed/torque)							
	100/100	P_v	W	76	101	132	216
	90/100	P_v	W	76	101	132	216
	90/50	P_v	W	55	65	88	126
	50/100	P_v	W	69	93	121	198
	50/50	P_v	W	51	60	85	121
	50/25	P_v	W	48	51	64	86
	0/100	P_v	W	–	76	–	–
	0/50	P_v	W	–	55	72	–
	0/25	P_v	W	–	47	58	78

	Symbol	Unit	DE1...-346D6...	DE1...-348D5...	DE1...-34011...	DE1...-34016...
Motor feeder						
Motor power assigned						
at 400 V, 50 Hz	P	kW	3	4	5.5	7.5
at 440 - 480 V, 60 Hz	P	HP	3	5	7.5	10
Apparent power at rated value						
at 400 V	S	kVA	4.57	5.89	7.62	11.09
at 480 V	S	kVA	5.49	7.07	9.15	13.30
Control section						
Relay						
Contact			S (RUN signal)			
Voltage, maximum	U	V	250 AC/30 DC	250 AC/30 DC	250 AC/30 DC	250 AC/30 DC
Load current, maximum	I	A	6 AC-1/5 DC-1	6 AC-1/5 DC-1	6 AC-1/5 DC-1	6 AC-1/5 DC-1
Reference voltage/Control voltage						
Output voltage	U _c	V	10	10	10	10
Max. permissible load current	I _c	mA	20	20	20	20
Analog input						
Resolution			12-bits	12-bits	12-bits	12-bits
Voltage	U _s	V	0 - +10	0 - +10	0 - +10	0 - +10
Current	I _s	mA	0/4 - 20	0/4 - 20	0/4 - 20	0/4 - 20
Digital Input						
High signal voltage level	U _c	V	9 - +30	9 - +30	9 - +30	9 - +30
Input current	I _c	mA	1.15 (10 V)/3 (24 V)	1.15 (10 V)/3 (24 V)	1.15 (10 V)/3 (24 V)	1.15 (10 V)/3 (24 V)
Enclosure						
Frame size			FS2	FS2	FS2	FS2
Dimensions (W x H x D)		mm	90 x 230 x 169	90 x 230 x 169	90 x 230 x 169	90 x 230 x 169
Maximum permissible deviation from vertical installation position		Degrees	90	90	90	90
Internal device fan			Yes	Yes	yes	yes
Degree of protection			IP20/NEMA 0	IP20/NEMA 0	IP20/NEMA 0	IP20/NEMA 0
Weight	m	kg	1.6	1.6	1.6	1.6

8 Technical Data

8.3 Rating data

	Symbol	Unit	DE1...-346D6...	DE1...-348D5...	DE1...-34011...	DE1...-34016...
Terminal capacities, clampable						
Power section						
Solid or stranded	A	mm ²	1 - 6	1 - 6	1 - 6	1 - 6
flexible with ferrule	A	mm ²	1 - 6	1 - 6	1 - 6	1 - 6
Solid or stranded	A	AWG	18 - 6	18 - 6	18 - 6	18 - 6
Strip length	l	mm	8	8	8	8
tool			PZ2 (Pozidrive) cross screwdriver			
Tightening Torque		Nm	1.2	1.2	1.2	1.2
Control section						
Solid or stranded	A	mm ²	0.05 - 1.5	0.05 - 1.5	0.05 - 1.5	0.05 - 1.5
flexible with ferrule	A	mm ²	0.5 - 1	0.5 - 1	0.5 - 1	0.5 - 1
Solid or stranded	A	AWG	30 - 16	30 - 16	30 - 16	30 - 16
Strip length	l	mm	5	5	5	5
tool			0.7 x 3 mm standard screwdriver			
Tightening Torque	M	Nm	0.5	0.5	0.5	0.5

8.4 Dimensions

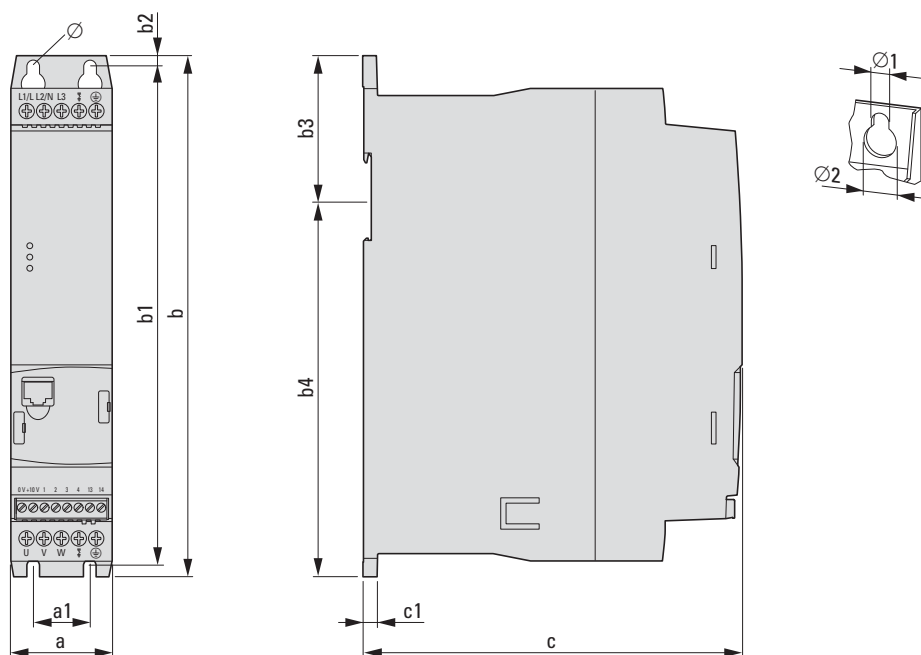


Figure 71: Dimensions

Table 38: Dimensions

Size	a mm (in)	a1 mm (in)	b mm (in)	b1 mm (in)	b2 mm (in)	c mm (in)	c1 mm (in)	Ø1 mm (in)	Ø2 mm (in)
FS1	45 (1.77)	25 (0.98)	230 (9.06)	220 (8.66)	5 (0.2)	168 (6.61)	6.5 (0.26)	5.1 (0.2)	10 (0.39)
FS2	90 (3.54)	50 (1.97)	230 (9.06)	220 (8.66)	5 (0.2)	168 (6.61)	6.5 (0.26)	5.1 (0.2)	10 (0.39)

1 in = 1" = 25.4 mm, 1 mm = 0.0394 in

8 Technical Data

8.4 Dimensions

9 Accessory devices

9.1 DX-KEY-LED2 external keypad and DX-KEY-OLED

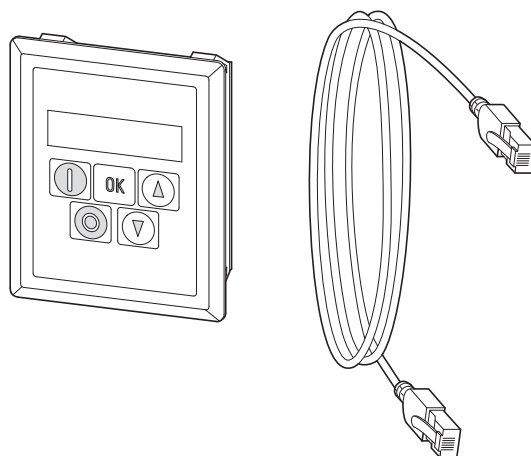


Figure 72: DX-KEY-LED2 with RJ45 cable (3 m)

The DX-KEY-LED2, DX-KEY-OLED keypad can be used to control DE1... variable speed starters externally, configure their parameters, and view their operational data. A 3 m-long connecting cable with RJ45 plugs is included as standard with the DX-KEY-LED2. The maximum permissible cable length is 100 m.

The DX-KEY-LED2 keypad is designed to be installed in a control panel door. The DX-KEY-LED2's degree of protection on the front is IP54.

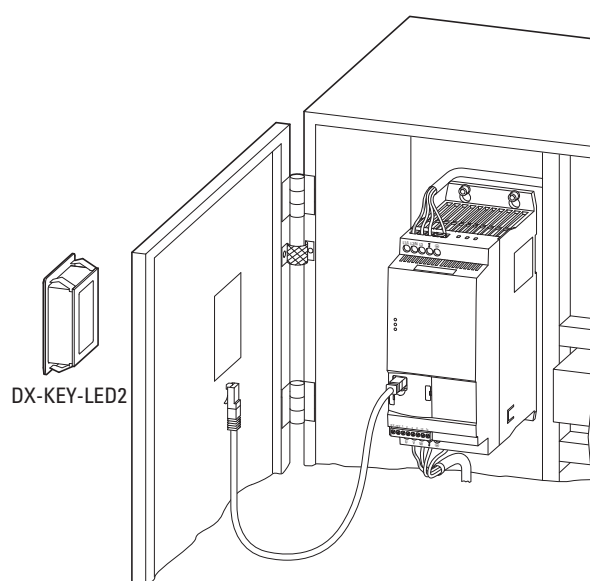


Figure 73: Mounting in a control panel door

9 Accessory devices

9.1 DX-KEY-LED2 external keypad and DX-KEY-OLED



For detailed instructions on how to install the external keypad, please refer to Instruction leaflet IL04012020Z.

A maximum of two keypads can be connected to a PowerXL network (OP bus).

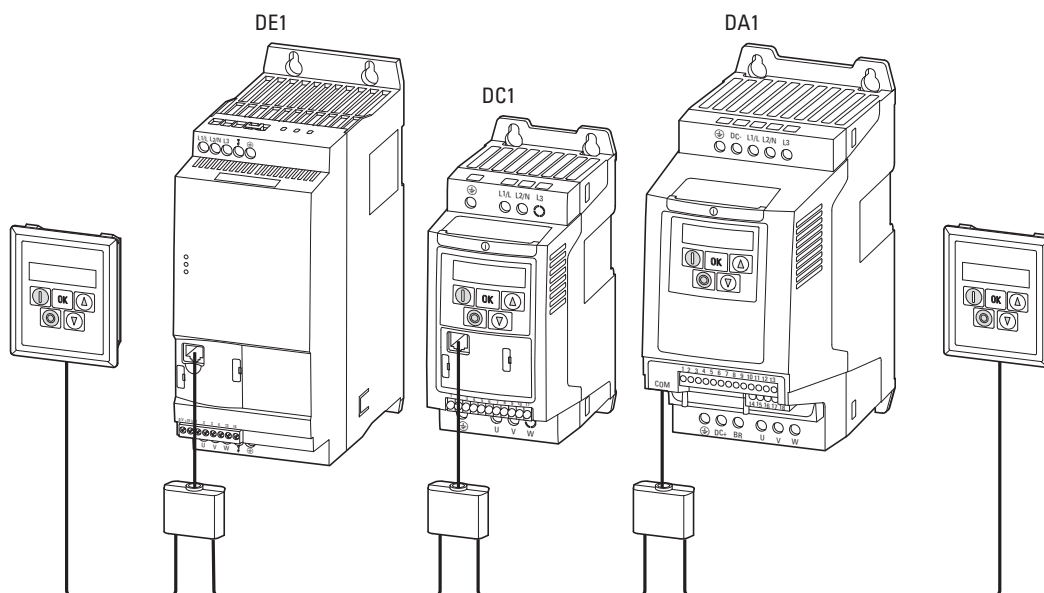


Figure 74: Example: PowerXL network (OP bus) with two keypads

If using two keypads, the second keypad's port address (PDP) must be changed to a value of 2 (default setting = 1). The individual modules are connected and selected using their PDP address, which can be set as follows:

- By using parameter P-36 in DC1 variable frequency drives
- By using parameter P5-01 in DA1 variable frequency drives
- By using parameter P-34 in DE1 variable speed starters

Table 39: Key combinations for port addresses

Function	Key combination
Keypad address	
DE1, DC1, DA1 address	

Setting the port address

The keypad's port address can be set by pressing the **OK + STOP + ▼** key combination at the same time. Display: *Port - 1*

Use the arrow keys to select the port address you want

(*Port - 1* or *Port - 2*). Then press the **OK + STOP + ▼** keys simultaneously again to store the setting in the keypad.

Setting the slave address



Setting module addresses is only possible with a direct (point-to-point) connection.

The addresses for the individual users can be set by pressing the **STOP + ▼** key combination at the same time. With the default setting, the display will show *Adr - 01*.

Use the arrow keys to assign the user address (*Adr - 01*, *Adr - 02* to

Adr - 63) you want. Then press the **STOP + ▼** keys simultaneously again to save the address in the corresponding device (DE1, DC1, DA1), after which the device's data will be loaded onto the keypad.

9.2 DX-COM-STICK3 communications stick

The DX-COM-STICK3 communication stick can be used to easily transfer parameters by:

- Copying all parameters to devices belonging to the same series (DE1, DC1, DA1), provided all the devices belong to the same rating category
- Copying all parameters – except for rating-related parameters – to devices belonging to the same series (DE1, DC1, DA1), regardless of the device model
- Transferring all parameters with a computer and an active Bluetooth connection.

This last option will require the use of the drivesConnect software. drivesConnect makes it possible to configure, use, diagnose, and display DE1 parameters in an intuitive and easy-to-use manner.

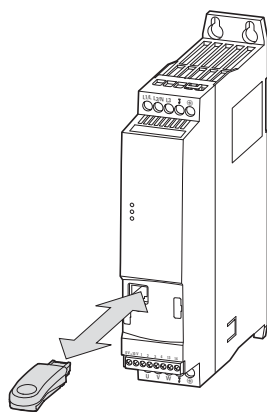


Abbildung 75: DE1... und DX-COM-STICK3

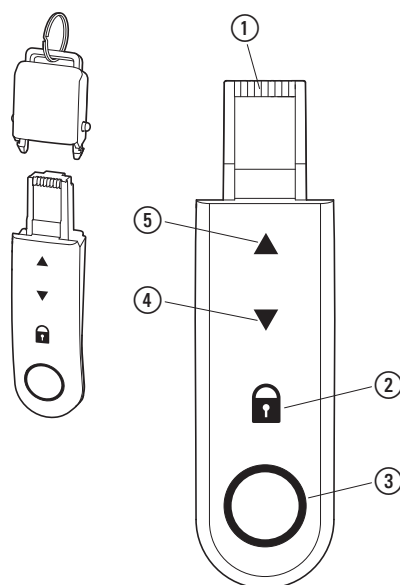


Figure 76: DX-COM-STICK3

- ① RJ45 plug-in connection
- ② Parameter write protection
- ③ LED – blue light
- ④ Button – Read data from connected device and store it
- ⑤ Button – Transfer data from DX-COM-STICK3 communication stick to connected device

The arrow buttons on the DX-COM-STICK3 communication stick can be used to control the direction in which parameters will be transferred:



The parameters will be copied from the DX-COM-STICK3 communications stick to the connected device (5).



The parameters will be copied from the connected device to the DX-COM-STICK3 communication stick (4).



For more information on the DX-COM-STICK3 Bluetooth communication stick, please refer to manual MN040003EN, "drivesConnect · Parameter Configuration Program for PowerXL™ Variable Speed Starters" and to Instruction leaflet IL04012021Z.



When transferring parameters between devices belonging to the DE1... series, it is important to note that it will only be possible to copy rating-related parameters (e.g., current values) to devices belonging to the same rating category.

In order to be able to establish a connection to a computer (with the drivesConnect parameter configuration program), the DX-COM-STICK3 Bluetooth communication stick needs to be activated with the "Add a Bluetooth Device" Windows function and code 0000.

When the DX-COM-STICK3 unit is being used, the three LEDs on the front of the DE1... variable speed starter will provide additional information.

LED	View	Description
Run	Flash for 2 s (4 Hz), green	Parameters successfully transferred
Status	off	
Fault Code	off	
Run	Flash for 2 s (4 Hz), green	Parameter transfer failed
Status	Flash for 2 s (4 Hz), red	
Fault Code	Flash for 2 s (4 Hz), red	
Run	Flash for 2 s (4 Hz), green	Reading/writing not possible because the DX-COM-STICK is locked, the DE1... is in RUN mode, or the DE1... part no. is not compatible.
Status	Flash for 2 s (4 Hz), yellow	
Fault Code	Flash for 2 s (4 Hz), yellow	

9 Accessory devices

9.3 SmartWire-DT DX-NET-SWD3

9.3 SmartWire-DT DX-NET-SWD3

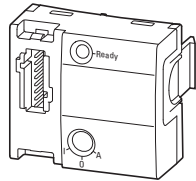


Figure 77: DX-NET-SWD3

The DX-NET-SWD3 option module can be used to connect a DE1... variable speed starter to SmartWire-DT. Together with a SmartWire-DT gateway, this makes it possible to communicate directly via, for example, PROFIBUS DP or PROFINET with the corresponding ProfiDrive profile.

The SmartWire-DT module needs to be plugged into the front of the DE1... variable speed starter and then connected to an SWD4-...LF8-... ribbon cable using an SWD4-8F2-5 external device plug.

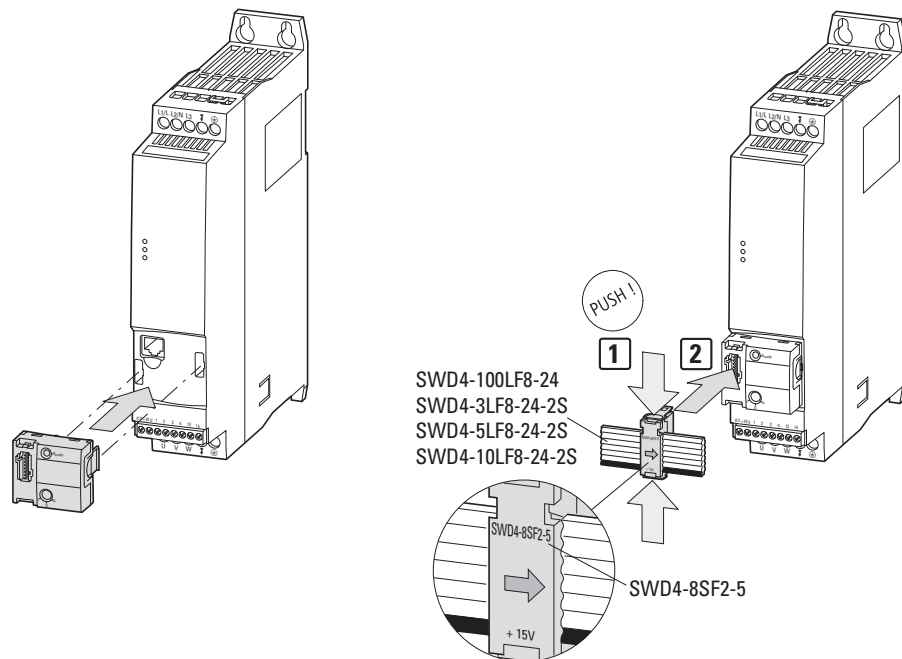


Figure 78: SmartWire-DT Connection



For detailed instructions on how to install the module, please refer to Instruction leaflet IL040009ZU.



For detailed instructions on how to use the DX-NET-SWD3 module, please refer to manual MN04012009Z-DE, "DX-NET-SWD... SmartWire-DT interface module for PowerXL™ variable frequency drive/variable speed starter".

9.4 DX-CBL-PC3M0 computer cable

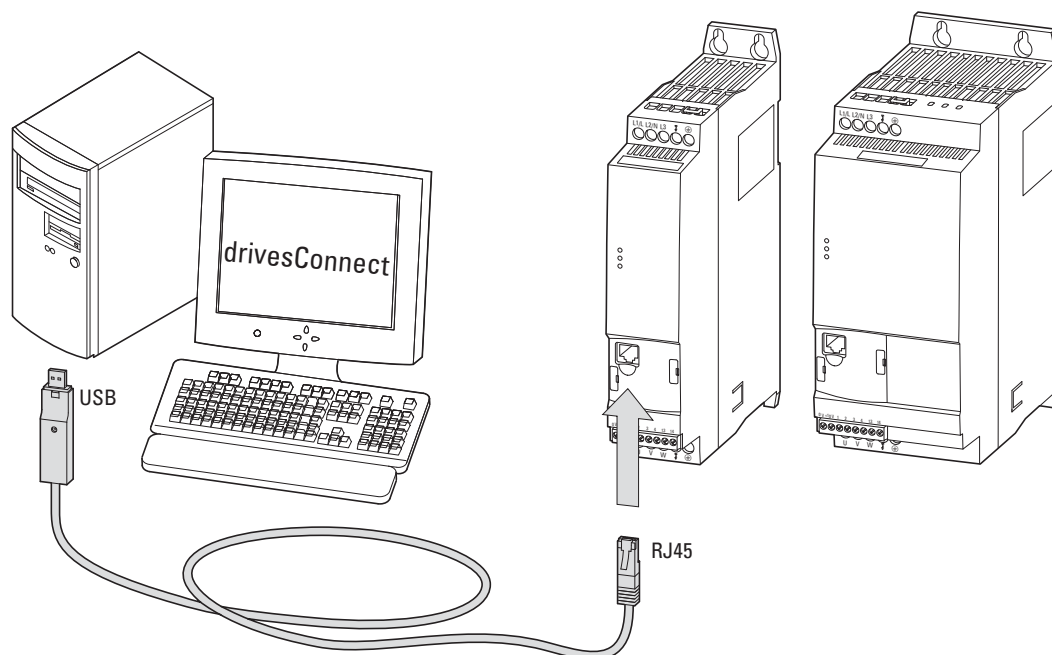


Figure 79: DX-CBL-PC-3M0

The DX-CBL-PC-3M0 computer connection cable can be used to establish wired, galvanically isolated communications between a DE1... variable speed starter and a computer with a Windows operating system (point-to-point connection) and the drivesConnect parameter software.

The connection cable is 3 m-long and has an RJ45 plug and a converter with a USB interface at the end (computer connection).



For more information on the DX-CBL-PC3M0 connection cable, please refer to manual MN040003EN, "drivesConnect Parameter Software for PowerXL™ Variable Frequency Drives", and to Instruction leaflet IL040002ZU.

9 Accessory devices

9.5 Cable and safety devices

9.5 Cable and safety devices

The mains cables and motor cables must be sized as required by local standards and by the load currents that will be involved. The rated operational currents are specified in Page 119 sqq.. Electric cables with adequate insulation for the specified mains voltages must be used. The PE conductor's conductivity must be the same as the phase conductors' conductivity (same cross-sectional area).

In order to meet CE and RCM requirements, a symmetrical, fully screened (360°) motor cable must be used. It is recommended to use a four-core cable in order to reduce the screening load resulting from leakage currents. A screened cable is not required on the mains side.

If the device is being installed as per UL standards, UL-listed fuses and copper cables with a temperature rating of +75 °C (167 °F) must be used. The motor cable must be an MC cable with a continuously corrugated aluminum armor and symmetrical protective earth conductors or – if armor is not used – a screened power cable. The motor cable's length will depend on the EMC category.

NOTICE

When selecting fuses and cables, make sure to always comply with all the regulations that apply at the installation site.

Table 40: Fusing and assigned cross-sectional areas

Device Type	Rated opera- tional current	Input current ¹⁾	Type of fuse	Conductor cross- section (L1/L, L2/N, L3, PE)		Motor cable (U, V, W, PE)	
	I_e A	I_{LN} A	A	mm ²	AWG ²⁾	mm ²	AWG ²⁾
DE1...-121D4...	1.4	3.6	10	1.5	14	1.5	14
DE1...-122D3...	2.3	6.2	10	1.5	14	1.5	14
DE1...-122D7...	2.7	7.3	10	1.5	14	1.5	14
DE1...-124D3...	4.3	11.3	15 ³⁾ /16	1.5	14	1.5	14
DE1...-127D0...	7	17.4	20	2.5	12	1.5	14
DE1...-129D6...	9.6	23.2	32/30 ³⁾	6	8	1.5	14
DE1...-341D3...	1.3	1.7	6	1.5	14	1.5	14
DE1...-342D1...	2.1	3.1	6	1.5	14	1.5	14
DE1...-343D6...	3.6	4.9	6	1.5	14	1.5	14
DE1...-345D0...	5	7	10	1.5	14	1.5	14
DE1...-346D6...	6.6	8.5	15 ³⁾ /16	1.5	14	1.5	14
DE1...-348D5...	8.5	10	15 ³⁾ /16	1.5	14	1.5	14
DE1...-34011...	11	12	15 ³⁾ /16	1.5	12	1.5	14
DE1...-34016...	16	16.5	25	4	10	2.5	12

- 1) Phase current on mains side (without mains choke)
- 2) AWG = American Wire Gauge
- 3) Fuse as per UL if using AWG wiring

The cable cross-sectional areas that can be properly clamped in place, as well as the stripping lengths, are provided in the technical data section (→ page 117ff.).

9 Accessory devices

9.5 Cable and safety devices

Table 41: Protective devices that should be used for DE1...-12... devices

Device Type	Input current ¹⁾ I_{LN}	Fuses (IEC)			Fuses (UL), Branch-Protection, AWG wiring required				
		A	Single-phase 230 V AC	Two-phase 230 V AC	A	SCCR 14 kA 1 pole: 277 V AC	2 pole: 480 Y/277 V AC	SCCR 100 kA Type J: 100 kA	PO no. Bussmann
DE1...-121D4...	3,6	10	FAZ-B10/1N	FAZ-B10/2	15	FAZ-B15/1-NA	FAZ-B15/2-NA	10 A	10NZ01
DE1...-122D3...	6,2	10	FAZ-B10/1N	FAZ-B10/2	15	FAZ-B15/1-NA	FAZ-B15/2-NA	10 A	10NZ01
DE1...-122D7...	7,3	10	FAZ-B10/1N	FAZ-B10/2	15	FAZ-B15/1-NA	FAZ-B15/2-NA	10 A	10NZ01
DE1...-124D3...	11,3	16	FAZ-B16/1N	FAZ-B16/2	15	FAZ-B15/1-NA	FAZ-B15/2-NA	15 A	16NZ01
DE1...-127D0...	17,4	20	FAZ-B20/1N	FAZ-B20/2	20	FAZ-B20/1-NA	FAZ-B20/2-NA	20 A	20NZ01
DE1...-129D6...	23,2	32	FAZ-B32/1N	FAZ-B32/2	30	FAZ-B30/1-NA	FAZ-B30/2-NA	30 A	32NZ02

1) Phase current on mains side (without mains choke)

Table 42: Protective devices that should be used for DE1...-34... devices

Device Type	Input current ¹⁾ I_{LN}	Fuses (IEC)		Fuses (UL), Branch-Protection, AWG wiring required					
		A	Three-phase 400/480 V AC	A	SCCR 14 kA 3 pole 480 Y/277 V AC	SCCR 18 kA 3 pole 480 Y/277 V AC	SCCR 100 kA Type J, CC or T	PO no. Bussmann	
DE1...-341D3...	1,7	6	FAZ-B6/3	PKM0-6,3 ²⁾ PKE12/XTU-12	15	FAZ-B15/3-NA ³⁾	PKZM0-32+BK25/ 3-PKZ0-E+AK-PKZ0	6	6NZ01
DE1...-342D1...	3,1	6	FAZ-B6/3	PKM0-6,3 ²⁾ PKE12/XTU-12	15	FAZ-B15/3-NA ³⁾	PKZM0-32+BK25/ 3-PKZ0-E+AK-PKZ0	6	6NZ01
DE1...-343D6...	4,9	6	FAZ-B6/3	PKM0-6,3 ²⁾ PKE12/XTU-12	15	FAZ-B15/3-NA ³⁾	PKZM0-32+BK25/ 3-PKZ0-E+AK-PKZ0	6	6NZ01
DE1...-345D0...	7	10	FAZ-B10/3	PKM0-10 ²⁾ PKE12/XTU-12	15	FAZ-B15/3-NA ³⁾	PKZM0-32+BK25/ 3-PKZ0-E+AK-PKZ0	10	10NZ01
DE1...-346D6...	8,5	16	FAZ-B16/3	PKM0-16 ²⁾ PKE32/XTU-32	15	FAZ-B15/3-NA ³⁾	PKZM0-32+BK25/ 3-PKZ0-E+AK-PKZ0	15	16NZ01
DE1...-348D5...	10	16	FAZ-B16/3	PKM0-16 ²⁾ PKE32/XTU-32	15	FAZ-B15/3-NA ³⁾	PKZM0-32+BK25/ 3-PKZ0-E+AK-PKZ0	15	16NZ01
DE1...-34011...	12	16	FAZ-B16/3	PKM0-16 ²⁾ PKE32/XTU-32	15	FAZ-B15/3-NA ³⁾	PKZM0-32+BK25/ 3-PKZ0-E+AK-PKZ0	15	16NZ01
DE1...-34016...	16,5	25	FAZ-B25/3	PKM0-25 ²⁾ PKE32/XTU-32	25	FAZ-B25/3-NA ³⁾	PKZM0-32+BK25/ 3-PKZ0-E+AK-PKZ0	20	25NZ02

1) Phase current on mains side (without mains choke)

2) Equivalent PKZM part nos. are permissible. However, please note that the overload release will not provide any direct protection for the motor.

3) Group protection, SCCR: 14 kA, 3 pole: 480 V/277 V AC

FAZ-B307/3-NA for all DE1...-34... combinations up to a total input current (I_{LN}) < 30 A

9.6 DIL...mains contactors



The mains contactors listed here are based on the DE1... variable speed starter's rated input-side mains current I_{LN} without a mains choke. They need to be selected based on the thermal current $\rightarrow I_{th} = I_e$ (AC-1) at the specified ambient temperature.

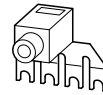
NOTICE

The inching operation is not permissible via the mains contactor (Pause time ≥ 30 s between switching off and on).

Figure 80: Mains contactor at single-phase connection

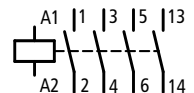
DILM12-XP1

P1DILEM



DILM

DILEM



DILM12-XP1

P1DILEM

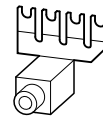


Table 43: Assigned mains contactors

Device Type	Rated operational current	Input current ¹⁾	Mains contactor	
	I_e A	I_{LN} A	AC-1 to 55 °C Part no.	AC-1 to 60 °C Part no.
DE1...-121D4...	1.4	3.6	DILEM-...+P1DILEM	DILM7-...+DILM12-XP1
DE1...-122D3...	2.3	6.2	DILEM-...+P1DILEM	DILM7-...+DILM12-XP1
DE1...-122D7...	2.7	7.3	DILEM-...+P1DILEM	DILM7-...+DILM12-XP1
DE1...-124D3...	4.3	11.3	DILEM-...+P1DILEM	DILM7-...+DILM12-XP1
DE1...-127D0...	7	17.4	DILEM-...+P1DILEM	DILM7-...+DILM12-XP1
DE1...-129D6...	9.6	23.2	DILM7-...+DILM12-XP1	DILM7-...+DILM12-XP1
DE1...-341D3...	1.3	1.7	DILEM-...	DILM7-...
DE1...-342D1...	2.1	3.1	DILEM-...	DILM7-...
DE1...-343D6...	3.6	4.9	DILEM-...	DILM7-...
DE1...-345D0...	5	7	DILEM-...	DILM7-...
DE1...-346D6...	6.6	8.5	DILEM-...	DILM7-...
DE1...-348D5...	8.5	10	DILEM-...	DILM7-...
DE1...-34011...	11	12	DILEM-...	DILM7-...
DE1...-34016...	16	16.5	DILEM-...	DILM7-...

1) Phase current on mains side (without mains choke)

Technical data on the mains contactors can be found in the main catalog HPL, Contactors DILEM and DILM 7.

9.7 DX-LN... mains chokes

The DE1... variable speed starter's rated input currents serve as the basis used to determine which mains chokes should be used.

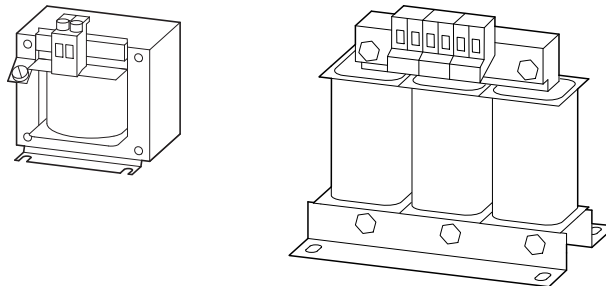


Figure 81: main chokes DEX-LN...


- ➔ If the DE1... variable speed starter is being run at its rated operational current limit, the variable speed starter's maximum possible output voltage (U_2) will be reduced to about 96 % of the mains voltage (U_{LN}) due to the mains choke at a u_k value of approximately 4 %.
- ➔ If using DE1...-34... variable speed starters, the mains choke's u_k value must not exceed 4 %, as these devices feature a "lean DC link".
- ➔ Mains chokes reduce the magnitude of the current harmonics up to about 30 % and increase the lifespan of variable speed starters and upstream-connected switchgear.
- ➔  Further information and technical data on the mains chokes of the DX-LN... series is provided in instruction leaflet IL00906003Z.

Table 44: Assigned mains chokes

Device Type	Rated current	Input current ¹⁾	Mains voltage (50/60 Hz)	Main choke	
	I_e A	I_{LN} A	U_{LNmax} V	Part no.	I_e A
DE1...-121D4...	1.4	3.6	240 +10 %	DX-LN1-006	6
DE1...-122D3...	2.3	6.2	240 +10 %	DX-LN1-006	6
DE1...-122D7...	2.7	7.3	240 +10 %	DX-LN1-009	9
DE1...-124D3...	4.3	11.3	240 +10 %	DX-LN1-013	13
DE1...-127D0...	7	17.4	240 +10 %	DX-LN1-018	18
DE1...-129D6...	9.6	23.2	240 +10 %	DX-LN1-024	24
DE1...-341D3...	1.3	1.7	480 +10 %	DX-LN3-004	4
DE1...-342D1...	2.1	3.1	480 +10 %	DX-LN3-004	4
DE1...-343D6...	3.6	4.9	480 +10 %	DX-LN3-006	6
DE1...-345D0...	5	7	480 +10 %	DX-LN3-010	10
DE1...-346D6...	6.6	8.5	480 +10 %	DX-LN3-010	10
DE1...-348D5...	8.5	10	480 +10 %	DX-LN3-010	10
DE1...-34011...	11	12	480 +10 %	DX-LN3-016	16
DE1...-34016...	16	16.5	480 +10 %	DX-LN3-016	16

1) Phase current on mains side (without mains choke)

9.8 External EMC filter

DX-EMC... radio interference suppression filters make it possible to use DE1... variable speed starters with longer motor cables, as well as with other EMC interference categories in the 1st and 2nd environments (IEC/EN 61800-3).

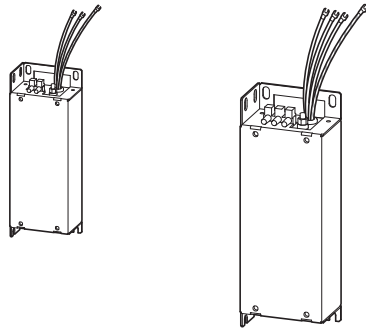


Figure 82: Radio interference suppression filter DX-EMC12... and DX-EMC34...

DX-EMC... external radio interference suppression filters should be installed in an upright vertical position to the left side of the DE1... variable speed starter.

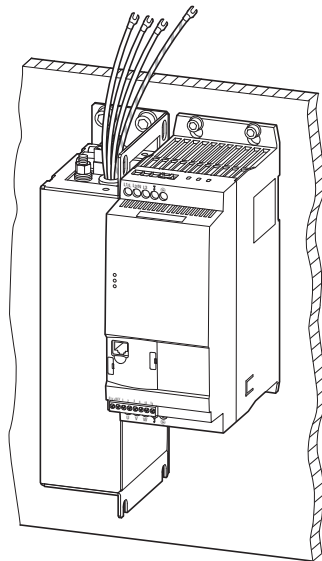


Figure 83: Installation position (example showing DX-EMC34-019... and DE1...-340... with FS2 frame size)



The prefabricated connection cables for DX-EMC... external EMC filters feature spade lug terminals. These spade lug terminals need to be removed in order to be able to connect the cables to a DE1 variable speed starter. The connection to the DE1... should be made as instructed in → page 45 (→ figure 31 and → table 6) and in compliance with local regulations.

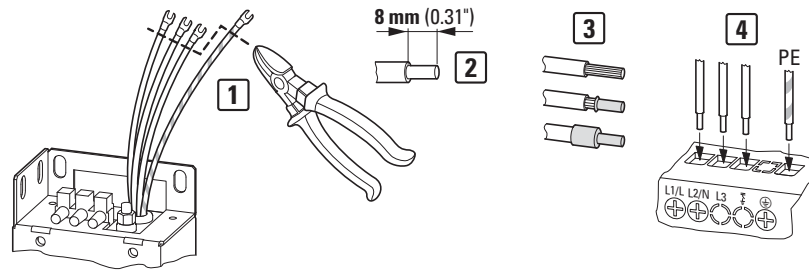


Figure 84: Modifying the prefabricated connection cables

The spade lug terminals must be removed directly at the point where they are connected [1]. The connection cables should not be shortened when doing so. In order to directly connect the cables to the DE1...’s power terminals (L/1, L2/N, L3, PE) [4], the cut cable ends must be stripped to a length of 8 mm [2]. If necessary, and in compliance with all applicable local regulations, ferrules or pin terminals can be installed at the stripped cable ends [3].



For more information and technical data on the DX-EMC... external radio interference suppression filters, please refer to the instruction leaflet IL04012017Z.

Table 45: Calibrated and assigned radio interference suppression filter

Variable speed starters	Associated external EMC filter Part no.	Motor cable length		
		EMC category		
		C1 ²⁾ m	C2 m	C3 m
Voltage class 220/240 V				
DE1...-121D4...	DX-EMC12-019-FS1	50	100	100
DE1...-122D3...				
DE1...-122D7...				
DE1...-124D3...				
DE1...-127D0...				
DE1...-129D6...				
DE1...-129D6...	DX-EMC12-025-FS2	50	100	100
Voltage class 380/400 V				
DE1...-341D3...	DX-EMC34-008-FS1 DX-EMC34-008-FS1-L ¹⁾ DX-EMC34-008 DX-EMC34-006-L	50 (25) ¹⁾	100	100
DE1...-342D1...				
DE1...-343D6...				
DE1...-345D0...				
DE1...-346D6...	DX-EMC34-016-FS3 DX-EMC34-016-FS3-L DX-EMC34-016 DX-EMC34-016-L	50	100	100
DE1...-348D5...				
DE1...-34011...				
DE1...-34016...				

1) Reduced motor cable length in category C1 when combining DE1...-34...NN... and reduced leakage current filter DX-EMC34-008-FS1-L

2) for conducted emissions only

9.9 Motor Choke DX-LM3...

It is recommended to use a motor choke if using long cable lengths and/or connecting several motors in parallel. The motor choke needs to be placed at the DE1... variable speed starter's output. Its rated operational current must always be equal to or greater than the variable speed starter's rated operational current.

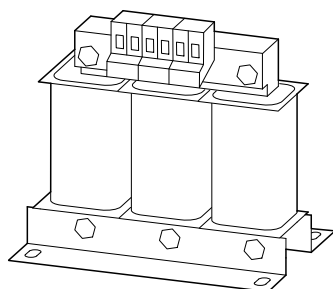


Figure 85: Motor Choke DX-LM3...

Advantages of using a motor choke

- Limits the dV/dt value
- Reduces voltage peaks
- Reduces bearing currents
- Motor life improvement (insulation, bearings)

Motor cable lengths if no motor chokes are used

- unscreened: 125 m
- screened: 65 m (+ approx. 50 % with motor choke, max. 150 m)



Take into account the maximum permissible motor cable lengths specified in IEC/EN 61800-3 for the relevant EMC interference category (C1, C2, C3 in first and second environments).

It is also recommended to use a motor choke at the DE1... variable speed starter's output if several motors with identical or different rated operational data are being run in parallel. In this case, the motor choke will compensate for the total resistance and total inductance decreases caused by the parallel-link and will attenuate the cables' higher stray capacitance.



Further information and technical data on the motor chokes of the DX-LM3... series is provided in instruction leaflet IL00906003Z.

Table 46: Motor chokes that should be used

Device Type		Motor choke that should be used	
Voltage class		Part no.	Rated operational current
200 - 240 V	380 - 480 V		I_e A
DE1...-121D4...	DE1...-341D3...	DX-LM3-005	5
DE1...-122D3...	DE1...-342D1...	DX-LM3-005	5
DE1...-122D7...	DE1...-343D6...	DX-LM3-005	5
DE1...-124D3...	DE1...-345D0...	DX-LM3-005	5
DE1...-127D0...	DE1...-346D6...	DX-LM3-008	8
DE1...-129D6...	DE1...-348D5...	DX-LM3-011	11
–	DE1...-34011...	DX-LM3-011	11
–	DE1...-34016...	DX-LM3-016	16

Notes:

- Maximum motor choke power supply (U_{max}): 750 V \pm 0%
- Maximum permissible output frequency f_2 : 200 Hz
- Maximum permissible pulse frequency (f_{PWM}) for DE1 device: 24 kHz (= P-29)

9 Accessory devices
9.9 Motor Choke DX-LM3...

10 Fault messages

DE1... variable speed starters feature several internal monitoring functions. If they detect a state deviating from a normal operating state, they will show a fault message:

- Operation will stop
- The **Status** LED will light up with a continuous red light
- The **Fault Code** LED will flash red (see list of faults)
- The relay contact (control terminal 13/14) will be opened

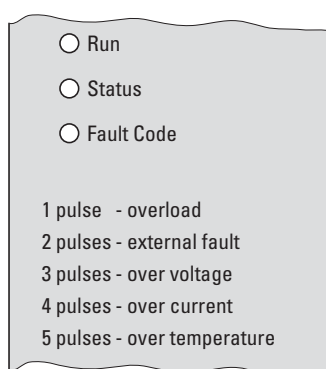


Figure 86: LED with fault message

If there is a fault message present, the **Status** LED will light up with a continuous red light. Meanwhile, the **Fault Code** will flash a number of times (pulses) corresponding to the fault. After a pause of two seconds, the series of pulses will be repeated again (flashing frequency: 2 Hz). The faults that occur most frequently in real-life applications are documented on the DE1... variable speed starter's housing:

Table 47: Fault messages on the DE1... variable speed starter's housing

Fault code (label on housing)	Cyclical flashing frequency of 2 Hz with 2-second pause	Meaning
1 pulse - overload	1 x	Thermal motor overload
2 pulses - external fault	2 x	External fault message
3 pulses - over voltage	3 x	Overvoltage
4 pulses - over current	4 x	Overcurrent
5 pulses - over temperature	5 x	Overtemperature

In the event of mains undervoltage, the green **Run** LED will turn off and the two red **Status** and **Fault Code** LEDs will flash synchronously with a frequency of 2 Hz.

When the mains voltage is switched on or returns, the two synchronously flashing **Status** and **Fault Code** LEDs will signal that the switched-mode power supply is working and the DE1... variable speed starter's operating state will be checked before the **Run** LED starts flashing.

10 Fault messages

10.1 Acknowledge fault message (Reset)

If the DE1... variable speed starter has an internal communication fault (CPU fault), the green **Run** LED will turn off and the **Status** and **Fault Code** LEDs will both show a continuous red light. → If this occurs, this means that the DE1 variable speed starter is faulty and must be replaced.

10.1 Acknowledge fault message (Reset)



The default setting for the DE1... variable speed starter is Auto-0 (P-30).

This means that, once a fault is fixed, the device will not be restarted automatically, but must be reset instead.

In this case, a rising edge is not required for the enable signal.

The enable signal (DI1 or DI2) can be linked to 10 V.

Fault messages can be reset as follows:

- By switching off the supply voltage and switching it back on
- By switching off the enable signal and switching it back on (FWD, REV, ENA)
- By pressing the STOP button if using an external keypad (DX-KEY-...)
- Via connections such as Modbus RTU, SmartWire-DT, PC (drivesConnect)

10.2 Fault log

The most recent fault messages will be saved in the order in which they occur (with the most recent one appearing first) and in parameter P-13.

The fault memory (P-13) can be read with:

- The optional external keypad (DX-KEY-...)
- The drivesConnect parameter software
- Modbus RTU,
- SmartWire-DT,
- CANopen – with DE11-...



The fault memory cannot be cleared. It will retain its information even if the device's default settings are restored.



When using the DX-KEY-LED2 keypad, it will only be possible to view the most recent fault and the three faults that preceded it.

The following example shows how to access the fault memory with the DX-KEY-LED2 keypad:

View	Description
	Operating state Stop
	Press the OK button and hold it down for two seconds.
	The most recently accessed parameter will be shown (e.g., P-00) The last digit on the display will flash.
	Use the ▲ (UP) and ▼ (DOWN) arrow keys to select the fault memory parameter (P-13) and confirm by pressing the OK button.
	Last fault message; Example: <i>P-dEF</i> (default parameters): The device was restored to its default settings.
	Press the ▲ (UP) arrow key to go to the next fault message.
	Second most recent fault message: Example: <i>U-UoL.t</i> (undervoltage signal). The decimal point on the right will flash (= second most recent fault message).
	If you press the ▲ (UP) arrow key, the third most recent fault message will be shown.
	Third most recent fault message: Example: <i>E-tr. iP</i> (external fault message). The two decimal points on the right will flash (= third most recent fault message).
	If you press the ▲ (UP) arrow key again, the fourth most recent fault message will be shown.
	Fourth most recent fault message; Example: <i>U-U.o.L.t</i> (undervoltage signal) The three decimal points on the right will flash (= fourth most recent fault message).

10 Fault messages

10.3 Fault list

10.3 Fault list

The following table lists the DE1... variable speed starter's fault messages, as well as possible causes and fixes:

- **Fault Code** LED (2 Hz + 2 s) = Number of flashing pulses plus a 2-second pause
- Modbus RTU [hex] = Hexadecimal fault code via Modbus
- DX-KEY-LED2 display = Fault code on the optional DX-KEY-LED2 keypad's 7-digital display assembly

Table 48: Fault messages

Fault Code LED (2 Hz + 2s) ¹⁾	Modbus RTU [hex]	Display DX-KEY-LED2 ²⁾	Designation	Possible cause/fixes
1 x	04	<i>l t - t r P</i>	Thermal motor overload	<ul style="list-style-type: none"> • If the decimal points are flashing or <i>DL</i> is displayed on an external keypad, this means that the motor current set in P-08 has been exceeded. The device will be switched off after a time of more than 100 % (l x t value). → Reduce the motor load or increase the acceleration time (P-03). → Check the current specifications on the motor's rating plate and the value in P-08, as well as the motor's configuration (star, delta).
2 x	0B	<i>E - t r i P</i>	External fault message	<ul style="list-style-type: none"> • The control voltage (HIGH level) at terminal 3 (DI3) has been switched off and the terminal is configured with the EXTFLT (P-15 = 1, 3, 5, 7, 9) function. → Check the motor's temperature or the external sensors if a thermistor is connected with this configuration.
3 x	06	<i>U u o l t</i>	Overvoltage	<ul style="list-style-type: none"> • Overvoltage in DC link → Check the mains-side supply voltage's magnitude. → If the fault message occurs during braking, this means that the regenerative energy is too high. In this case, increase the deceleration time (P-04).
4 x	03	<i>I - I</i>	Overcurrent	<ul style="list-style-type: none"> • Fault message immediately after enable signal or start command → Check the motor connection for line-to-line or earth faults. • Fault message during start phase: → Check whether the motor can rotate freely (blocked, mechanical brake). → Check the motor's configuration (star, delta). → Increase acceleration time P-03. → Lower start voltage P-11. • Fault message during constant speed → Check the drive for overload (shock load) or malfunction. • Fault message during speed change → Check the drive for oscillating loads (e.g., in the case of pumps and fans).
5 x	08	<i>T - t</i>	Overtemperature	<ul style="list-style-type: none"> • Overtemperature at internal heat sink Please check the following: → Does the ambient temperature meet specifications? → Is there enough air circulation around the DE1... variable speed starter (clearances above and underneath)? → Are the vents clear? → In the case of devices with an internal fan: Is the fan running?

Fault Code LED (2 Hz + 2s) ¹⁾	Modbus RTU [hex]	Display DX-KEY-LED²⁾	Designation	Possible cause/fixes
6 x	05	<i>P5-ErrF</i>	Power section fault	<ul style="list-style-type: none"> • Fault message from the power section's output. → Check the connection to the motor (short-circuit, earth fault). → Disconnect the cable from terminals U, V, W. → If the fault message cannot be reset, please contact your closest Eaton office.
7 x	0C	<i>5C-ErrF</i>	Communication fault	<ul style="list-style-type: none"> → Check the connection between the RJ45 interface and external devices. → Make sure that every device on the network has a unique address.
8 x	0A	<i>P-defF</i>	Default parameter settings	<ul style="list-style-type: none"> • The parameter's default setting has been loaded. → Press the STOP button on the external keypad.
9 x	–	<i>FLt-dc</i>	DC residual ripple	<ul style="list-style-type: none"> • The DC link voltage's residual ripple is too high. → Check whether all three mains voltage phases are present and whether the voltage difference between the mains phases is smaller than 3%. → Reduce the motor load. → If the fault message cannot be reset, please contact your closest Eaton office.
10 x	12	<i>4-ZOF</i>	Live zero error	<ul style="list-style-type: none"> • The current signal at analog input AI1 has fallen below 3 mA. → Check the current source and the wiring to control terminals 4 and 0 V.
11 x	09	<i>U-t</i>	Under-temperature	<ul style="list-style-type: none"> • The ambient temperature is lower than -10 °C (frost). → Raise the ambient temperature to a temperature above -10 °C.
12 x	10	<i>th-FLt</i>	Thermistor fault	<ul style="list-style-type: none"> • Faulty thermistor on internal heat sink. → Please contact your closest Eaton representative.
13 x	11	<i>DATA-F</i>	Data error	<ul style="list-style-type: none"> • The modified parameters were not saved (flash memory) and the default settings have been loaded instead. → If the problem occurs again, please contact your closest Eaton representative.

1) 2 Hz "Fault Code" LED flashing frequency with 2-second pause

2) Optional external keypad

10 Fault messages

10.3 Fault list

11 List of parameters

Following is an overview of all the parameters in DE1... variable speed starters, including a brief description.

The abbreviations and acronyms used in the overview are defined below:

Abbreviation	Meaning
Panel Code	Panel Code – parameter designation used by the drivesConnect parameter software and the external DX-KEY-LED2 keypad's display.
Panel Code ¹⁾	The parameter's values will not be copied if the parameters are copied to a DE1... variable speed starter with a different output rating.
RUN	Access rights to the parameters during operation (RUN)
STOP	The parameter can only be accessed in STOP mode
ro/rw	Parameter read and write permissions: ro = read only rw = read and write
Name	Short parameter name
Value	<ul style="list-style-type: none"> Setting value of the parameter value range Display value
DS	Default setting (the parameter's value when using the device's factory settings) The values in parentheses are the default settings when using a frequency of 60 Hz.
Page	The page number in this manual containing a detailed description of the parameter.

Table 49: Parameter list

Page Code	Modbus ID	Access right		Name	Value	DS	Description	Page
		RUN, STOP	ro/rw					
P-01	129	STOP	rw	f-max	P-02 - 300.0 Hz	50 Hz (60 Hz)	Sets the upper limit for the speed of the motor. This can be set to any value between "f-min" and 5x the "motor nom frequency". "Motor Nom Speed" (P-10) = 0, the maximum speed limit will be displayed in Hz. "Motor Nom Speed" (P-10) > 0, the maximum speed limit will be displayed in rpm.	88
P-02	130	STOP	rw	f-min	0 Hz - P-01	0Hz	Sets the lower limit for the speed of the motor This can be set to any value between 0 and "f-max" (P-01). "Motor Nom Speed" (P-10) = 0, the minimum speed limit will be displayed in Hz. "Motor Nom Speed" (P-10) > 0, the minimum speed limit will be displayed in rpm.	88
P-03	131	RUN	rw	t-acc	0.1 - 300 s	5.0 s	Sets the acceleration ramp time in seconds. The time interval set in "t-acc" represents the time taken to accelerate from zero to "Motor Nom Frequency" (P-09).	88

11 List of parameters

Page Code	Modbus ID	Access right		Name	Value	DS	Description	Page
		RUN, STOP	ro/rw					
P-04	132	RUN	rw	t-dec	0.1 - 300 s	5.0 s	<p>Sets the deceleration ramp time in seconds.</p> <p>The time interval set in "t-dec" represents the time taken to decelerate from "Motor Nom Frequency" (P-09) to zero.</p>	88
P-05	133	RUN	rw	Stop Mode	0; 1	1	<p>Determines the action taken by the drive in the event of the drive enable signal being removed.</p> <p>0 : Coasting. When the enable signal is removed, the drive output is immediately disabled, and the motor will coast (freewheel) to stop.</p> <p>1: Ramping. When the enable signal is removed, the drive will ramp to stop, with the rate controlled by "t-dec" (P-04).</p>	89
P-06	134	STOP	rw	EnergyOptimizer	0; 1	0	<p>When energy optimization is activated, the motor voltage is dynamically varied, dependent on load. This results in reduced voltage being applied to the motor on light load, significantly reduce energy consumption. This mode of operation is less suitable for dynamic applications where the load conditions can suddenly increase significantly.</p>	96
P-07 ¹⁾	135	STOP	rw	Motor Nom Voltage	50 - 500 V	220 V, 230 V, 380V, 400 V, 460 V	<p>Defines the Motor rated voltage.</p> <p>When the output frequency is greater than the "Motor Nom Frequency" (P-09), the output voltage is controlled at the level set with "Motor Nom Voltage" (P-07).</p>	92
P-08 ¹⁾	136	STOP	rw	Motor Nom Current	$(10 - 100\%) \times I_e$	I_e	<p>Motor rated current.</p> <p>By setting the "Motor Nom Current" in the speed starter, the motor overload protection is configured to match the motor rating.</p> <p>When the measured motor current exceeds "Motor Nom Current", the decimal points on the display (option) will flash to indicate an overload condition.</p> <p>If this condition persists, the speed starter will eventually trip, displaying $I\bar{L} - \bar{L} - P$, preventing thermal overload of the motor.</p>	92
P-09	137	STOP	rw	Motor Nom Frequency	20.0 - 300 Hz	50 Hz (60Hz)	<p>The rated frequency of the motor.</p> <p>This is the frequency at which "Motor Nom Voltage" is applied to the motor. Below this frequency, the applied motor voltage will be reduced. Above this frequency the voltage remains limited to "Motor Nom Voltage".</p>	92
P-10	138	STOP	rw	Motor Nom Speed	0/200 - 15000 rpm (18000 rpm)	0	<p>Motor rated speed</p> <p>P-10: 0: the speed of the motor will be displayed in Hz. P-10 > 0: the speed related parameters (f-max, f-min etc.) will be displayed in rpm.</p> <p>The slip compensation is also activated, where the shaft speed of the motor is maintained under varying load conditions by compensating for the load-dependent slip of the motor.</p> <p>If "Motor Nom Speed": motor synchronous speed (e.g. 3000rpm for a 2-pole 50Hz motor), the speed can be displayed in rpm without activating the slip compensation.</p>	92

11 List of parameters

Page Code	Modbus ID	Access right		Name	Value	DS	Description	Page
		RUN, STOP	ro/rw					
P-11	139	RUN	rw	V-Boost	0.0 - 40.0 %	–	Voltage is used to increase the applied motor voltage at low output frequency, in order to improve low speed and starting torque. Excessive voltage boost levels may result in increased motor current and temperature, and forced ventilation may be required.	96
P-12	140	RUN	rw	Local ProcessData Source	0 - 13	0	Local Configuration of Command and Reference Sources 0: Terminal Control. The drive responds directly to signals applied to the control terminals. 1: Uni-directional Keypad Control. The drive can be controlled in the forward direction only using an external or remote Keypad 2: Bi-directional Keypad Control. The drive can be controlled in the forward and reverse directions using an external or remote Keypad. Pressing the keypad START button toggles between forward and reverse. 3: Modbus Control. Control via Modbus RTU communication. 9: SmartWire-DT Device Control and speed ref. 10: SmartWire-DT Device Control and terminal speed ref. 11: Terminal Control and SmartWire-DT Device speed ref. 12: Not allowed 13: SmartWire-DT Device Control and speed ref. Digital input sets enable.	102 ff.
P-13 ¹⁾	141	STOP	ro	Last Fault1 PDP – Last Fault4 PDP	Most recent fault – fourth-last fault	–	last fault - last but seven fault	112
P-14	142	RUN	rw	Password	0 - 65535	0	Entry of the password to get access to the extended parameter set. The value to be put in is determined by P-38 (default: 101). Extended parameters are accessible.	111

11 List of parameters

Page Code	Modbus ID	Access right		Name	Value	DS	Description	Page																																																							
		RUN, STOP	ro/rw																																																												
Extended parameter range (default access code: P-14 = 101)																																																															
P-15	143	STOP	rw	DI Config Select	0 - 9	0	<p>Function of the control terminals When P-12 = 0, control signal terminals DI1 to DI4 can be configured with the following functions:</p> <table border="1"> <thead> <tr> <th>Mode</th> <th>DI1</th> <th>DI2</th> <th>DI3</th> <th>AI1/DI4</th> </tr> </thead> <tbody> <tr> <td>0</td> <td>FWD</td> <td>REV</td> <td>Select REF/f-Fix1</td> <td>REF</td> </tr> <tr> <td>1</td> <td>FWD</td> <td>REV</td> <td>EXTFLT</td> <td>REF</td> </tr> <tr> <td>2</td> <td>FWD</td> <td>REV</td> <td>Select f-Fix Bit0</td> <td>Select f-Fix Bit1</td> </tr> <tr> <td>3</td> <td>FWD</td> <td>Select REF/f-Fix1</td> <td>EXTFLT</td> <td>REF</td> </tr> <tr> <td>4</td> <td>FWD</td> <td>UP</td> <td>Select REF/f-Fix1</td> <td>DOWN</td> </tr> <tr> <td>5</td> <td>FWD</td> <td>UP</td> <td>EXTFLT</td> <td>DOWN</td> </tr> <tr> <td>6</td> <td>FWD</td> <td>REV</td> <td>UP</td> <td>DOWN</td> </tr> <tr> <td>7</td> <td>FWD</td> <td>Select f-Fix Bit0</td> <td>EXTFLT</td> <td>Select f-Fix Bit1</td> </tr> <tr> <td>8</td> <td>START</td> <td>DIR</td> <td>Select REF/f-Fix1</td> <td>REF</td> </tr> <tr> <td>9</td> <td>START</td> <td>DIR</td> <td>EXTFLT</td> <td>REF</td> </tr> </tbody> </table> <p>Note: The assigned control signal terminal functions will depend on the value set in P-12.</p>	Mode	DI1	DI2	DI3	AI1/DI4	0	FWD	REV	Select REF/f-Fix1	REF	1	FWD	REV	EXTFLT	REF	2	FWD	REV	Select f-Fix Bit0	Select f-Fix Bit1	3	FWD	Select REF/f-Fix1	EXTFLT	REF	4	FWD	UP	Select REF/f-Fix1	DOWN	5	FWD	UP	EXTFLT	DOWN	6	FWD	REV	UP	DOWN	7	FWD	Select f-Fix Bit0	EXTFLT	Select f-Fix Bit1	8	START	DIR	Select REF/f-Fix1	REF	9	START	DIR	EXTFLT	REF	95, 102
Mode	DI1	DI2	DI3	AI1/DI4																																																											
0	FWD	REV	Select REF/f-Fix1	REF																																																											
1	FWD	REV	EXTFLT	REF																																																											
2	FWD	REV	Select f-Fix Bit0	Select f-Fix Bit1																																																											
3	FWD	Select REF/f-Fix1	EXTFLT	REF																																																											
4	FWD	UP	Select REF/f-Fix1	DOWN																																																											
5	FWD	UP	EXTFLT	DOWN																																																											
6	FWD	REV	UP	DOWN																																																											
7	FWD	Select f-Fix Bit0	EXTFLT	Select f-Fix Bit1																																																											
8	START	DIR	Select REF/f-Fix1	REF																																																											
9	START	DIR	EXTFLT	REF																																																											
P-16	144	STOP	rw	AI1 Signal Range	0 - 3	0	<p>Configures the Analog input 1 for the selected signal source type.</p> <p>0 - 10 V 0 - 20 mA t 4 - 20 mA (Trip in case of wire break) r 4 - 20 mA (Ramps to f-fix1 (P-20) in case of wire break)</p>	110																																																							
P-17	145	RUN	rw	AI1 Gain	0.10 - 2,500	1,000	<p>Scaling of the Analog Input 1</p> <p>Output value = Input value * Scaling. Example: P-16 = 0 - 10 V, P-17 = 2,000: at 5 V the motor turns with max speed (P-01) (5 V * 2 = 10 V)</p>	110																																																							
P-18	146	STOP	rw	AI1 Invert	0; 1	0	<p>Setting this parameter to 1 inverts the logic of the analog input.</p> <p>0: 0 V / 0(4) mA = min frequency, 10 V / 20 mA = max frequency 1: 0 V / 0(4) mA = max frequency, 10 V / 20 mA = min frequency</p>	110																																																							
P-19	147	STOP	rw	DI3 Logic	0; 1	0	<p>This parameter defines the logic of the digital input 3.</p> <p>0: High = ok, Low = Fault 1: Low = ok, High = Fault (when P-15 is set to 1,3,5, 7 or 9 (External Fault))</p>	95																																																							
P-20	148	STOP	rw	f-Fix1	P-02 – P-01	20Hz	<p>Preset Fixed Frequency 1 Value can be adjusted between f-min and f-max. Selection via a digital control signal.</p>	101																																																							
P-21	149	STOP	rw	f-Fix2	P-02 – P-01	30Hz	<p>Preset Fixed Frequency 2 Value can be adjusted between f-min and f-max. Selection via a digital control signal.</p>	101																																																							

11 List of parameters

Page Code	Modbus ID	Access right		Name	Value	DS	Description	Page
		RUN, STOP	ro/rw					
P-22	150	STOP	rw	f-Fix3	P-02 – P-01	40Hz	Preset Fixed Frequency 3 Value can be adjusted between f-min and f-max. Selection via a digital control signal.	101
P-23	151	STOP	rw	f-Fix4	P-02 – P-01	50 Hz	Preset Fixed Frequency 4 Value can be adjusted between f-min and f-max. Selection via a digital control signal.	101
P-24	152	RUN	rw	Digital Reference Reset Mode	0, 1, 2, 3	0	Defines the behavior of the drive on START when used in Keypad control or when controlled with UP/DOWN commands via terminals. 0: Start at min speed 1: Start with latest speed before switching off 2: Start at min speed (Auto-r) 3: Start with latest speed before switching off (Auto-r) Auto r: START and STOP button on the keypad are disabled. DE1 starts with a START command at the terminals.	108
P-25	153	STOP	rw	DCBrake	0, 1, 2, 3	0	Sets the instances when DC braking is enabled. 0: OFF 1: On at Stop 2: On before Start 3: On before Start and at Stop	99
P-26	154	RUN	rw	t-DCBrake@Stop	0 - 10 s	0.0 s	Duration of DC braking at Stop and before Start	99
P-27	155	RUN	rw	DCBrakeVoltage	(0 - 100%) of P-07	0.0 s	Amount of DC voltage as a percentage of the "Motor Nom Voltage" that is applied to the motor during DC braking.	99
P-28	156	RUN	rw	f-DCBrake@Stop	0 - P-01	0.0Hz	Output frequency in Hz at which DC braking starts during the deceleration phase. If "Stop Mode" is set to coasting, DC braking starts at stop command immediately.	99
P-29 ¹⁾	157	STOP	rw	Switching Frequency	4 - 32 kHz 10 - 20 kHz	16 kHz	Power stage switching frequency. Higher frequency reduces the audible "ringing" noise from the motor, and improves the output current waveform, at the expense of increased heat losses within the drive. ATTENTION: In case a sine wave filter is used, the switching frequency has to be in the range which is permissible for the filter. In this case P-29 has to be set to twice the switching frequency mentioned on the filter. Example: Sine wave filter for 6 kHz --> Setting of P-29: 12 kHz!	–

11 List of parameters

Page Code	Modbus ID	Access right		Name	Value	DS	Description	Page
		RUN, STOP	ro/rw					
P-30	158	STOP	rw	Start Mode	EdgE-r, Auto-0 - Auto-9	Auto-0	<p>Defines the behaviour of the drive relating to the enable digital input and also configures the automatic restart function.</p> <p>Edge-r : Following power on or reset, the drive will not start if a start signal (FWD/REV) is still present. To start DE1 a rising edge is necessary.</p> <p>Auto-0 : Following a power on or reset, the drive will automatically start if digital input 1 is closed.</p> <p>Auto-1 to 9 : Following a trip, the drive will make up to 9 attempts to restart at 20 second intervals. The drive must be powered down to reset the counter. The number of restart attempts are counted, and if the drive fails to start on the final attempt, the drive will trip, and will require the user to manually reset the fault.</p> <p>ATTENTION: An automatic restart is only possible when the control commands are given via terminals (P-12 = 0 and P-12 = 11).</p>	–
P-31	159	RUN	rw	Overvoltage Control	0; 1	0	<p>The over voltage control prevents the drive from tripping in case of regenerative energy feedback from the motor to the DC link. When disabled, the drive will trip “Over Voltage” instead of automatically increasing the motor ramp times when the drive is decelerating the motor too quickly.</p> <p>0: ON. Overvoltage Controller enabled 1: OFF. Overvoltage Controller disabled</p>	89
P-32	160	STOP	rw	Auto Thermal Management	0; 1	0	<p>AutoThermalManagement</p> <p>When disabled, the drive will trip “Over Temperature” instead of automatically reducing the power stage switching frequency when the drive gets hot.</p> <p>0: ON. Thermal management enabled 1: OFF. Thermal management disabled</p>	147
P-33	161	STOP	rw	T-Memory Enable	0; 1	0	<p>When enabled, the motor thermal memory retention function will save the calculated motor thermal history on drive power down, using this saved value as the starting value on next power up. If this function is disabled, the motor thermal history is reset to zero on every power up.</p> <p>0: ON. Thermal memory enabled 1: OFF. Thermal memory disabled</p>	94
P-34	162	RUN	rw	PDP-Address	1, 2, ... ,63	1	<p>Unique drive address in a communication network. for OP bus and CANopen</p>	–
P-35	163	RUN	rw	RS485-0 Baudrate	0, 1, 2, 3, 4	4	<p>RS485 Baudrate</p> <p>0: 960 Bit/s 1: 19.2 kBit/s 2: 38.4 kBit/s 3: 57.6 kBit/s 4: 115.2 kBit/s</p>	–

11 List of parameters

Page Code	Modbus ID	Access right		Name	Value	DS	Description	Page
		RUN, STOP	ro/rw					
P-36	164	RUN	rw	Modbus RTU0 COM Timeout	0, 1, ... ,8	0	<p>Modbus RTU0 COM Timeout</p> <p>Time between a communication loss and the resulting action. Setting "0" disables the action after communications trip. t: indicates the drive will trip if time exceeded. r: indicates the drive will ramp to stop if time exceeded.</p> <p>0: no action 1: t 30 ms 2: t 100 ms 3: t 1000 ms 4: t 3000 ms 5: r 30 ms 6: r 100 ms 7: r 1000 ms 8: r 3000 ms</p>	–
P-37	165	STOP	rw	Parameter Set	0; 1	0	Restores factory parameter settings.	112
P-38	166	RUN	rw	Password Level2	0 - 9999	101	<p>Defines the password which is used to get access to extended parameter set (Level 2). Access via P-14.</p>	111
P-39	167	RUN	rw	Parameter Lock	0; 1	0	<p>Determines whether to lock the parameters</p> <p>0: OFF. All parameters can be accessed and changed 1: ON. Parameter values can be displayed, but cannot be changed. If a remote keypad is connected, parameters cannot be accessed by the remote keypad if they are locked.</p>	111
P-40	168	RUN	rw	Action@Communication Loss	0, 1, 2, 3, 4	0	<p>Device reaction after occurring of "Communication Loss". Possibilities device dependent</p> <p>Drive reaction after SWD master communication loss. Master communication loss delay time is set by "Modbus RTU0 COM Timeout" (P-36) 0: No reaction, continue work 1: Set warning, continue work 2: stop (if ramp enabled) 3: coast stop 4: Trip</p>	–
P-41	169	RUN	rw	ParameterAccess	0; 1	0	<p>Parameter Access</p> <p>0: All parameters can be changed by any source. 1: All parameters locked; can only be changed by the SWD Device.</p>	112
P-42	170	RUN	rw	f-SkipBand1	0 Hz - P-01	0 Hz	<p>Skip frequency band width Defines the frequency range around f-Skip1 in which the drive doesn't work in steady-state to avoid mechanical resonances in the application.</p>	
P-43	171	RUN	rw	f-Skip1	0 Hz - P-01		Centre point of the frequency band defined by f-Skip-Band1 in which the drive doesn't work in steady-state.	
P-44	172	RUN	rw	A11 Offset	-2.500 - 2.500	0.000	Offset Analog Input 1	

11 List of parameters

Page Code	Modbus ID	Access right		Name	Value	DS	Description	Page
		RUN, STOP	ro/rw					
P-45	173	RUN	rw	FireMode Function	0, 1, 2, 3, 4	0	<p>Defines the device function in applications that use Fire Mode.</p> <p>The only settings allowed for P-15 are those in which terminal 3 is assigned the function EXTFLT (i.e. P-15 = 1, 3, 5, 7, 9).</p> <p>The LED status indicates operation in Fire Mode (3 blinks, pause for 2 seconds).</p> <p>During Fire Mode the activation signals (START, FWD, REV) have no function.</p> <p>0: Fire Mode disabled 1: Fire Mode 1 <ul style="list-style-type: none"> Eliminating the signal to terminal 3 activates the Fire Mode and the motor operates clockwise (FWD). The setpoint value in Fire Mode corresponds to the analog value at terminal 4 (AI1). If this setpoint value is omitted or is zero when the switch occurs, the motor operates at fixed frequency 4 (f-Fix4 = P-23). 2: Fire Mode 2 <ul style="list-style-type: none"> Eliminating the signal to terminal 3 activates the Fire Mode and the motor operates counter-clockwise (REV). The setpoint value in Fire Mode corresponds to the analog value at terminal 4 (AI1). If this setpoint value is omitted or is zero when the switch occurs, the motor operates at fixed frequency 4 (f-Fix4 = P-23). 3: Fire Mode 3 <ul style="list-style-type: none"> Eliminating the signal to terminal 3 activates the Fire Mode and the motor operates clockwise (FWD). The setpoint value in Fire Mode is equal to fixed frequency 4 (f-Fix4 = P-23). 4: Fire Mode 4 <ul style="list-style-type: none"> Eliminating the signal to terminal 3 activates the Fire Mode and the motor operates counter-clockwise (REV). The setpoint value in Fire Mode is equal to fixed frequency 4 (f-Fix4 = P-23). </p>	
P-46	174	RUN	rw	Motor Stator Resistance R1	0.00 - 655.35	–	Stator resistance of the motor	
P-47	175	RUN	rw	RS485-0 Address	0 - 255	1	Unique Modbus RTU address, regardless of the address set in P-34	
P-48	176	RUN	rw	RS485-0 ParityType	0, 1, 2, 3	0	RS485-0 parity 0: 1 stop bit, no parity 1: 2 stop bit, no parity 2: 1 stop bit, odd parity 3: 1 stop bit, even parity	

Page Code	Modbus ID	Access right		Name	Value	DS	Description	Page
		RUN, STOP	ro/rw					
DE11-... variable speed starters only								
P-50	179	RUN	rw	AI1 Offset	0, 1, 2, 3	2	CANopen Baudrate	
P-51	180	RUN	rw	FireMode Function	0, 1, ... ,9	0	Selection of the function of output relay RO1	
P-52	181	RUN	rw	Motor Stator Resistance R1	0.0 - 200.0 %	100 %	Switching ON threshold of relay RO1	
P-53	182	RUN	rw	RS485-0 Address	0.0 - 100.0 %	0.0 %	Hysteresis for relay output 1	
P-54	183	RUN	rw	RS485-0 ParityType	0.0 - 250.0 s	0.0 s	Delay time before the Relay switches from logic 0 to logic 1.	

Display parameters, monitor

Extended parameter range (default access code: P-14 = 101)

Table 50: Display parameters, monitor

Page Code	Name	Value	Description
P0-01	Analog Input1	0,0 - 100 %	Analog Input 1 Level of the signal applied to analog input 1 after scaling and offsets have
P0-02	–	–	–
P0-03	Frequency Reference	0,0 - 300 Hz	Frequency Reference in Hz. Will be calculated into rpm when motor data are available Value of the drive internal digital reference (used for keypad)
P0-04	DI1 Status	0000 - 1111	Status of the Digital Inputs Status of the digital inputs starting on the left hand side with digital input 1 etc.
	DI2 Status		
	DI3 Status		
	DI4 Status		
P0-05	Motor Current	0 - 150 % I_e	Instantaneous output current
P0-06	Output Frequency	0,0 - 300,0 Hz	Instantaneous output frequency
P0-07	Motor Voltage	0 - 480 V RMS	Instantaneous output voltage
P0-08	DC-Link Voltage	V	Instantaneous DC Link Voltage
P0-09	Heatsink Temperature	°C	Instantaneous Heatsink Temperature
P0-10	t-Run	h (min, s)	Total operating time of the drive since the date of manufacture Displayed in hours, minutes and seconds. Pressing the UP key on the drive keypad will change the display from "hours" to "minutes and seconds".
P0-11	t-Run since Restart	h (min, s)	Run time since power on or last Reset Total operating time of the drive since the last trip occurred or the last power ON in hours, minutes and seconds. Pressing the UP key on the drive keypad will change the display from "hours" to "minutes and seconds".
P0-12	t-Run since Trip	h (min, s)	Total operating time of the drive since the last trip occurred Displayed in hours, minutes and seconds. Pressing the UP key on the drive keypad will change the display from "hours" to "minutes and seconds".
P0-13	t-HoursRun Enable	h (min, s)	Total operating time of the drive since the last drive ENABLE signal was applied. Displayed in hours, minutes and seconds. Pressing the UP key on the drive keypad will change the display from "hours" to "minutes and seconds".

11 List of parameters

Page Code	Name	Value	Description
P0-14	Actual Switching Frequency	16 kHz	Actual switching frequency. The value may be less than the one set with P-29 when the thermal management of the heatsink is active.
P0-15	DC-Link0 Log	000	DC link voltage log Recording of the most recent 8 samples of the DC bus voltage prior to a drive trip condition occurring. The sample interval is 256 ms.
	DC-Link1 Log		
	DC-Link2 Log		
	DC-Link3 Log		
	DC-Link4 Log		
	DC-Link5 Log		
	DC-Link6 Log		
	DC-Link7 Log		
P0-16	Heatsink0 Log	00	Heatsink temperature log Recording of the most recent 8 samples of the heatsink temperature prior to a drive trip condition occurring. The sample interval is 30 s.
	Heatsink1 Log		
	Heatsink2 Log		
	Heatsink3 Log		
	Heatsink4 Log		
	Heatsink5 Log		
	Heatsink6 Log		
	Heatsink7 Log		
P0-17	MotorCurrent0 Log	0,0	Motor current log Recording of the most recent 8 samples of the Motor current prior to a drive trip condition occurring. The sample interval is 256 ms.
	MotorCurrent1 Log		
	MotorCurrent2 Log		
	MotorCurrent3 Log		
	MotorCurrent4 Log		
	MotorCurrent5 Log		
	MotorCurrent6 Log		
	MotorCurrent7 Log		
P0-18	Application Version	0,00 (00C0)	Application Version
	System Version		System Version
P0-19	Serial Number	123456 (78-000)	Serial Number of the device (don't use for new devices, see 4400.0 ff.)
P0-20	FrameSize		Frame Size
	NoOfInputPhases		Number of input phases
	kW/HP	0,37 - 7,50	Motor Power
	Power@Ue		Device Power at Device Voltage Rating
	Device Voltage		Device Voltage Rating
	DeviceType		Device Type
P0-21	FaultCounter Fire detected		Counts, how often "Fire detected" occurred
P0-22	t-FireMode Active		Run time in Fire Mode

11 List of parameters

Index

A

Abbreviations	8
AC supply systems	25
Accessories	131
Air circulation	36
Ambient conditions	18, 20
Ambient temperature	18
Analog input	55
Analog input, scaling	109
Antiresonances	27

B

Block diagrams	63
Boost	97
Brake chopper	14, 15
Bus termination resistor	59
Bypass connection	30

C

Cable	138
Cable cross-sections	28
CE marking	19
Checklist	65
Commissioning	65
Configuration module	71
Connecting EX motors	34
Connecting the power section	42
Connection cables	48
Connection examples	44, 54
Connection of control signal terminals (example)	69
Connection on mains side	42
Connection to corner-earthed networks	25
Connection to IT networks	19
Contact current	119, 123
Control cables	52
Control section	51
Control signal terminals	100
Control terminals	51, 94

D

DC braking	99
DC link	21
DE1 series	9
Default settings	112, 153
Degree of protection	14, 117
Delay time	88

Delta circuit	34
Designation	15
Designation, on DE1 variable speed starter	16
Dimensions	129
Disconnecting device	28
Disconnecter	28
Display parameter	164
Display unit	15
Displaying operational data	113
drivesConnect	86
DX-CBL-PC3M0	137
DX-COM-STICK3	134
DX-KEY-LED2	79, 81
DX-LM3...	146
DX-LN...	142
DX-NET-SWD3	136
DXE-EXT-SET	71

E

Earth-fault loop impedance	45
Electrical power network	25
EMC filter	144
EMC jumper	43, 46
EMC measures	31
ENA	101
Engineering	23, 24
Equipment supplied	12
Ex motors	34

F

Fault list	152
Fault messages	149
Features	117
Fixing, on mounting rails	39
Fixing, with screws	38
Fuses	28

H

Harmonics	27
Hazard warnings, operational	66
Heat dissipation	120, 123, 126
Hotline (Eaton Industries GmbH)	21

I					
I x t characteristic	93				
Inching operation	67				
Inspection	20				
Installation	35				
Instruction leaflet, IL040005ZU	12				
Insulation resistance	41				
Insulation test	41				
Internal DC link capacitors	21				
IT network, connection	25				
L					
Leakage currents	29				
LED indicators	61				
M					
Magnet system	24				
Main choke	28, 142				
Mains cable insulation	41				
Mains connection	25				
Mains contactor	30, 141				
Mains supply voltages	9				
Mains voltage	18, 26				
Mains voltage, North American	9				
Maintenance (maintenance activities)	20				
Maintenance intervals	20				
Manufacturing date	14				
Monitor	164				
MOR	101				
Motor cable, screened	49				
Motor choke	146				
Motor connection	48				
Motor data	91				
Motor, explosion-proof	34				
Motor-protective circuit-breaker (PKE)	33				
Mounting	35				
Mounting positions	36				
Mounting rail	39				
N					
Nameplate	13				
Network configuration	25				
O					
Operating unit	79, 81				
Overload protection	93				
P					
Parallel connection of motors	33				
Parameter list	155				
Parameter lock	111				
Parameters, setting	85				
Parameters, Upload/Download	135				
Part no.	14				
Password	111				
Power Drive System -> (magnet system)	24				
Power networks,					
phase-earthed delta networks	25				
Power networks, ring	9				
Power networks, star	9				
Power networks, starpoint-earthed	9				
Power section	42				
Power terminals	43				
Proper use	19				
R					
Radio interference suppression filter					
DX-EMC...	144				
DX-EMC34...	144				
Rated motor current	18				
Rated operational data	13, 118				
Rated operational data, on nameplate	14				
Rating data	119				
Rating plate	34				
RCD	29				
Regulations	118				
Relay contact	58				
Reset	108, 150				
Residual Current Circuit Breakers	29				
RJ 45 interface	59, 80				
S					
Safety features	138				
Selection criteria	18				
Serial number	14				
Service	21				
Slip compensation	91, 96				
SmartWire-DT	87, 106				
Standards	19, 25, 26, 28, 30, 35, 39				
IEC 60364	I				
IEC 60364-4-41	I				
IEC/EN 60204-1	I				
Star connection	34				
Storage	20				
Strip length	45, 53				
Supply voltage	18, 40				
System earthing	45				

System overview 11

T

Technical Data 117

Terminal capacity 53

Testing the motor cable insulation 41

Thermistor protection 94

Three-phase motor 34

U

UL installation 50

Units of measurement 9

US installation 29

V

V/Hz Ratio 96

Voltage categories 17

Voltage drop, permissible 9

Voltage source, external 56

W

Warranty 21

Wiring system 18, 34