



BAUMÜLLER

POWER CONVERTER

BKD 6 / ... 6000

BKF12 / ... 6000

Technical description and
operation manual

Edition 11. January 1996

E	5.95001.02
----------	------------

BAUMÜLLER

POWER CONVERTER

BKD 6/ ... 6000, BKF 12/ ... 6000

Technical description and operation manual

Edition January 1996

5.95001.02

**PLEASE READ AND PAY ATTENTION TO SAFETY INSTRUCTIONS
AND OPERATING GUIDE PRIOR TO COMMISSIONING**

This manual contains the necessary information for normal operation of the products described therein. The drives may only be used, maintained and repaired by personnel familiar with the operation manual and the applicable regulations on working safety and accident prevention. The devices are manufactured to a high technical specification and are operationally safe. Provided that all safety instructions have been adhered to, there will be no personal danger during the installation and commissioning stages.

The commissioning is prohibited until it has been positively determined that the machine, into which these components are to be incorporated, complies with EC machine regulations.

This technical description replaces and nullifies all previous description. In order to provide the best possible service, we reserve the right to alter information without notice.

Manufacturer and Baumüller Nürnberg GmbH

Supplier's address: Ostendstr. 80
90482 Nürnberg
Germany

Tel. (++49-911) 5432 - 0

Fax (++49-911) 5432 - 130

Copyright: The technical description and the operation manual may not be copied or duplicated without our permission.

Country of origin: Made in Germany

Date of manufacture: Determined from the serial number on the machine/motor.

TABLE OF CONTENTS

1 Safety Information..... 1

2 Technical Data..... 5

 2.1 General..... 5

 2.2 Type Code 9

 2.3 Technical Data of Power Converter Units..... 10

 2.4 Technical Data of Field Power Converter 12

 2.5 Technical Data of Mains Unit 13

 2.5.1 Standard Version with Conventional Mains Unit..... 13

 2.5.2 Special Version with Switching Mains Unit and External 24-V Supply 14

 2.6 Technical Data of Power stage..... 15

 2.7 Technical Data of Processor Board 3.8934 16

 2.8 Technical Data of Supplementary Modules 20

 2.8.1 "Dual DAC 12", Daughterboard 3.9201 20

 2.8.2 "Input/Output Expansion", Daughterboard 3.9217 20

 2.8.3 InterBus-S Interface Board, 3.9208 22

 2.8.4 RS232, RS485 Interface Card, 3.8947 23

 2.8.5 RS485 with USS Protocol or as a CS31 System Bus Interface, 3.9493 24

 2.9 Power Loss of Power Converter, Line Converter and Fuses..... 25

 2.10 Construction Drawings 26

 2.10.1 CPU Board 3.8934..... 26

 2.10.2 Field Supply 3.8942 30

 2.11 Adapting Power Converters to Different Connection Voltages 38

3 Transportation And Unpacking..... 39

4 Assembly 41

 4.1 Dimensions 42

 4.1.1 BKD 6 and BKF12 .../6000, Size I (30 A to 200 A) 43

 4.1.2 BKD 6 and BKF12 .../6000, Size II (300 A to 600 A) 45

 4.1.3 BKD 6 and BKF 12 .../6000 Sizes III and IV 47

 4.2 Weights 53

 4.3 Assembly Information 54

5 Installation 57

 5.1 Danger and Warning Information 57

 5.2 Standardization Information 58

 5.3 Connection Plans..... 59

 5.3.1 Connecting Controller Module Sizes I ... IV 60

 5.3.2 Connecting Power Stage BKF 12/6000 Sizes I ... IV 67

 5.3.3 Connecting Power Stage BKD 6/6000 Sizes I ... IV 74

Table of Contents

5.4 Connecting Daughterboards.....	84
5.4.1 "Dual DAC 12", 3.9201 Daughterboard	84
5.4.2 "Input/Output Expansion", 3.9217 Daughterboard	85
5.4.3 InterBus-S Interface Board	90
5.4.4 RS 232, RS 485 Interface Board.....	91
5.4.5 RS485 with USS Protocol or as a CS31 System Bus Interface, 3.9493.....	92
5.5 Position of the Electrical Connections and Modules	94
5.5.1 BKD 6 and BKF 12 .../6000, Size I (30 A to 200 A)	94
5.5.2 BKD 6 and BKF 12 .../6000, Size II (300 A to 600 A)	94
5.5.3 Controller and Field Supply for Sizes III and IV (750 A to 2050 A)	95
5.6 Semiconductor Fuses	96
5.6.1 Unit Size I.....	96
5.6.2 Unit Size II.....	98
5.6.3 Unit Size III.....	98
5.6.4 Unit Size IV	99
5.6.5 Fuse Sizes.....	99
5.6.6 Field Semiconductor Fuses	99
5.7 Line Commutators	100
5.8 Accessories	103
6 Functions	105
6.1 Function Plans.....	105
6.2 Specifying the Controller Structure.....	111
6.3 Nominal Value Assignment.....	114
6.4 Current Limits	119
6.4.1 Current Limits for the Armature.....	119
6.4.2 Current Limitation at the Field Current Converter.....	121
6.5 Monitoring.....	122
6.5.1 Ready for Use Relay K1	122
6.5.2 Relay K2.....	123
6.5.3 Relay K3.....	124
6.5.4 Linking the Armature Current Monitoring Relays of K2 and K3.....	126
6.5.5 Relay K4.....	127
6.5.6 Displaying and Checking the Relay Functions.....	129
6.6 Analog Output on Measuring Channels 1 ... 4	130

6.7 Controlling the Power Converter, Sequence of Switching On and Off	134
6.7.1 Enables on the Power Converter and Main Contactor Control	134
6.7.2 Additional Switching and Control Inputs	140
6.7.3 Sequence of Switching On and Off	145
6.8 Automatic Restarting after Brief Mains Disturbances	149
6.8.1 Standard Unit	149
6.8.2 Automatic Restart for Special Versions with a Switching Mains Unit	151
6.9 Load Measurement with Cranes (S04.12 and above)	153
7 Commissioning	157
7.1 Danger and Warning Information	157
7.2 Operating the Power Converter	160
7.2.1 Overview	160
7.2.2 Keypad and Display on the Power Converter	161
7.2.3 Operation Using a PC	165
7.3 Commissioning Guidelines	182
7.3.1 Stock-Taking	182
7.3.2 Parameterization	184
7.3.3 Equipment Set-Up	190
7.4 Configuration and Commissioning Record	196
7.5 Parameter Documentation	197
8 Parameters	207
9 Maintenance	251
9.1 Maintenance Information	252
9.2 Error Messages	253
9.3 Error List	255
9.4 Spares	261
9.4.1 Modules and Complete Units	261
9.4.2 Replacement boards, Daughterboards and Individual Parts	262
9.5 Disposal	263
10 Appendix	265
10.1 Complementary Documentation	265
10.2 Manufacturer Declaration	266
10.3 Declaration of Conformity	267
10.4 Conditions of Business and Delivery	268
10.5 Index	268

Abbreviations

ABBREVIATIONS

BSA	Reference voltage, analog	M24	24-V reference potential
BSE	External reference for 24-V control inputs	MM	Torque signalling
DAC	Digital/analog converter	MTL	Medium time-lag (fuse)
EXT, ext	External	n = 0	RPM = 0
HE	Main contactor ON	n _{act}	Speed actual value
I _{Aact}	Armature voltage actual value	n _{nom}	Speed nominal value
+ I _{Aact}	Amount of armature voltage actual value (pos. signal)	R _A	Armature resistance
IF	Pulse enable	RF	Controller enable
I _{Fmax}	Maximum field current (nominal current)	SH	Fast brake
I _{Fmin}	Minimum field current	TD1	Torque direction 1
I _{Fnom}	Field current nominal value	TD2	Torque direction 2
INC.	Incremental	X	Terminal strip
I _{nom}	Armature voltage nominal value	\$	Prefix for hexadecimal number
LED	Light-emitting diode		

1 SAFETY INFORMATION

Preliminary Remarks

During operation, the principles on which the power converter and the motor work lead to leakage currents to earth occur that may be dissipated via the specified protective earths and may result in a current-operated e.l.c.b. on the input side blowing prematurely.

In the case of a short-circuit to frame or to ground, a direct proportion may arise in the leakage current that makes triggering a higher-level current-operated e.l.c.b. either more difficult or totally impossible.

This means that connecting the power converter to the mains using only the current-operated e.l.c.b. is prohibited (preliminary standard EN 50178/VDE 0160/11.94, Sections 5.2.11 and 5.3.2.1)

The units are protected from direct contact by being installed in commercially available switching cabinets that meet the minimum protection requirements of preliminary standard EN 50178/VDE 0160/ 11.94, Section 5.2.4.

Sheets of plastic covering the control electronics, the power stage and the equipment connection act as additional guards preventing accidental contact at commissioning and in the case of casual use of control elements located close to the equipment (DIN VDE 0106 Part 100, Accident Prevention Regulation VBG4 "Electrical Systems and Equipment").

At routine testing of this equipment, a high-voltage test is carried out that conforms with preliminary standard EN 50178/VDE 0160/11.94, Section. 9.4.5.

The protective measures and safety regulations according to DIN/VDE are binding for personal security. Neglecting to fit PE connections on the equipment or the motor will result in serious personal injury and/or considerable damage to property.

General Information

These operating instructions contain all the information necessary for correct operation of the products described. The document is intended for specially trained, technically qualified personnel who are well-versed in all warnings and commissioning activities. The equipment is manufactured using state-of-the-art technology and is safe in operation. It can safely be installed and commissioned and functions without problems if the safety information in these operating instructions is followed.



WARNING

When operating electrical equipment, some parts of the equipment always carry dangerous voltages. Ignoring these safety instructions and warnings may result in serious personal injury and/or damage to property.

Only qualified personnel who are familiar with the safety information, assembly, operation and maintenance instructions may carry out work on this equipment.

Safety Information

Danger Information

On the one hand, the information below is for your own personal safety and on the other to prevent damage to the described products or to other connected equipment.

In the context of the operating instructions and the information on the products themselves, the terms used have the following meanings:

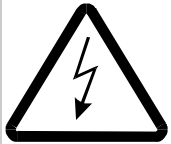

DANGER

This means that death, severe personal injury, or damage to property **will** occur unless appropriate safety measures are taken.



WARNING

This means that death, severe personal injury, or damage to property **may** occur unless appropriate safety measures are taken.

NOTE

This draws your attention to important information about the product, handling of the product or to a particular section of the documentation.

Qualified Personnel

In the context of the safety-specific information in this document or on the products themselves, qualified personnel are considered to be persons who are familiar with setting up, assembling, commissioning and operating the product and who have qualifications appropriate to their activities:

Trained or instructed or authorized to commission, ground and mark circuits and equipment in accordance with recognized safety standards.

Trained or instructed in accordance with recognized safety standards in the care and use of appropriate safety equipment.

Appropriate Use



WARNING

You may only use the equipment/system for the purposes specified in the operating instructions and in conjunction with the third-party equipment and components recommended or authorized by BAUMÜLLER NÜRNBERG GmbH.

For safety reasons, you must not change or add components on/to the equipment/system.

The machine minder must report immediately any changes that occur which adversely affect the safety of the equipment/system.

2 TECHNICAL DATA

2.1 General

BAUMOTRONIC Series 6000 power converters are line-commutated units for speed-controlled DC drives with microprocessor closed-loop control.

Single- and four-quadrant versions are available, which differ only in the version of the power unit used for armature control:

In the case of the BKD 6/.../...-6000 single-quadrant version, the power stage is a fully controlled three-phase current bridge circuit (B6C); with the BKF12/.../...-6000 four-quadrant version by contrast, the power stage is a circular current-free counter-parallel circuit (B6C)2I.

In general, a B2HKF semi-controlled two-phase bridge, which is controlled by the microprocessor, is used as the field supply.

Single-quadrant power converters have rated currents of between 30 A and 2050 A; rated currents of between 30 A and 1650 A are available for four-quadrant versions.

This means that it is possible to run on a 500-V 3~ industrial supply DC drives with power ranges of approximately 5 kW to 800 kW in the case of four-quadrant power converters (armature voltage 520 V) and up to approximately 1100 kW with single-quadrant versions (armature voltage 600 V).

The equipment series is divided into four performance levels that are designated in general as unit size I to IV. They differ from one another by virtue of the construction and size of the power stages and the arrangement of the open-loop and closed-loop control module.

Size I and size II units have the tried and tested compact structure. The power stage is in the lower part of the device and comprises electrically insulated thyristor modules on a potential-free heat sink. The control electronics, including the microprocessor PCB, are mounted above the power stage and separated from it by a metal panel to ensure interference immunity.

Size III and size IV units consist of two modules, i.e. the control unit and the power stage; these components must be mounted separately next to one another in the control cabinet. Amongst other things, the closed-loop control module contains the microprocessor PCB, the mains unit and the field controller and it is contained in its own housing. The two units are electrically connected via a plug-in bus cable. The thyristor block is fitted with disk-type thyristors.

In the case of size I and size II units, the necessary phase and armature fuses must be arranged externally, whereas with size III and size IV units, the units already contain semiconductor fuses.

With this series, a powerful 16-bit microprocessor system, which is located on the microprocessor PCB, carries out open- and closed loop control, communications and general signal processing. The PCB and the rest of the electronic components, such as the mains unit and the field unit are the same with all unit sizes. The microprocessor PCB is a lid board: this means that you can easily reach all the relevant components and they are accessible from the front. The power converter's operating software is stored in two plug-in EPROMs that you can easily replace if necessary.

Parameters and data sets are stored on the lid board in a plug-in EEPROM. If required, you can pre-program it. You can also carry out parameterization via an external controller.

This versatile series of equipment can be used in a wide variety of applications:

First of all, this series is intended to replace existing analog equipment such as BKF 12../2000, BKF 12../3000 or BKD 6../2000. The appropriate analog nominal value and additional inputs and digital control inputs are already available.

The equipment achieves optimum efficiency when linked with PCs, PLCs, NCs or CNCs. Adaptation to various bus systems is possible, for example, by means of supplementary modules (interface boards) that you can optionally fit on the lid board. It is possible to fit a maximum of two supplementary modules.

Features

- Signal processing
 - By means of a 16-bit 68000 microprocessor
- Operation
 - By means of an integrated keyboard, display via LEDs and seven-segment displays
 - Optionally menu-driven via PC (standard RS232, 9600 bps) for rapid commissioning and documentation
- Controller structures
 - Speed control via tachometer generator with/without field weakening
 - Speed control via incremental encoder (option) with/without field weakening
 - Armature voltage control with constant field
 - Torque control with constant field
- Four data sets
 - Freely programmable for adaptation to different applications
 - If technically sensible, switchable online via the serial interface or terminals even during operation:

from tachometer control to e.m.f. control
(in the case of a tachometer breakdown)

from constant field to field weakening
(to extend the speed range)

from one drive stage to another

different nominal value sources (inching, ext. nominal value,
motor potentiometer)

- 16 nominal value sources including, amongst others, analog or digital nominal value source, nominal value generator, inching function and motor potentiometer function
- Ramp function generator and S-ramp generator
- Microprocessor-controlled field supply, with or without field weakening as well as zero-speed field
- Mains monitoring and connection monitoring on the AC and DC sides (also applies to tachometer connection)
- Control via decoupled partially programmable switching inputs
- Analog input, e.g. for external current limits or reversing direction of rotation
- Up to four 0 – ± 10 V analog outputs for continuous checking of 47 test points within the unit
- One non-digitized 0 – ± 10 V analog output for display of armature voltage
- Indication of the operating status by means of four partially programmable relay outputs
- Power converters BKD and BKF completely identical except for the power stages

2.2 Type Code

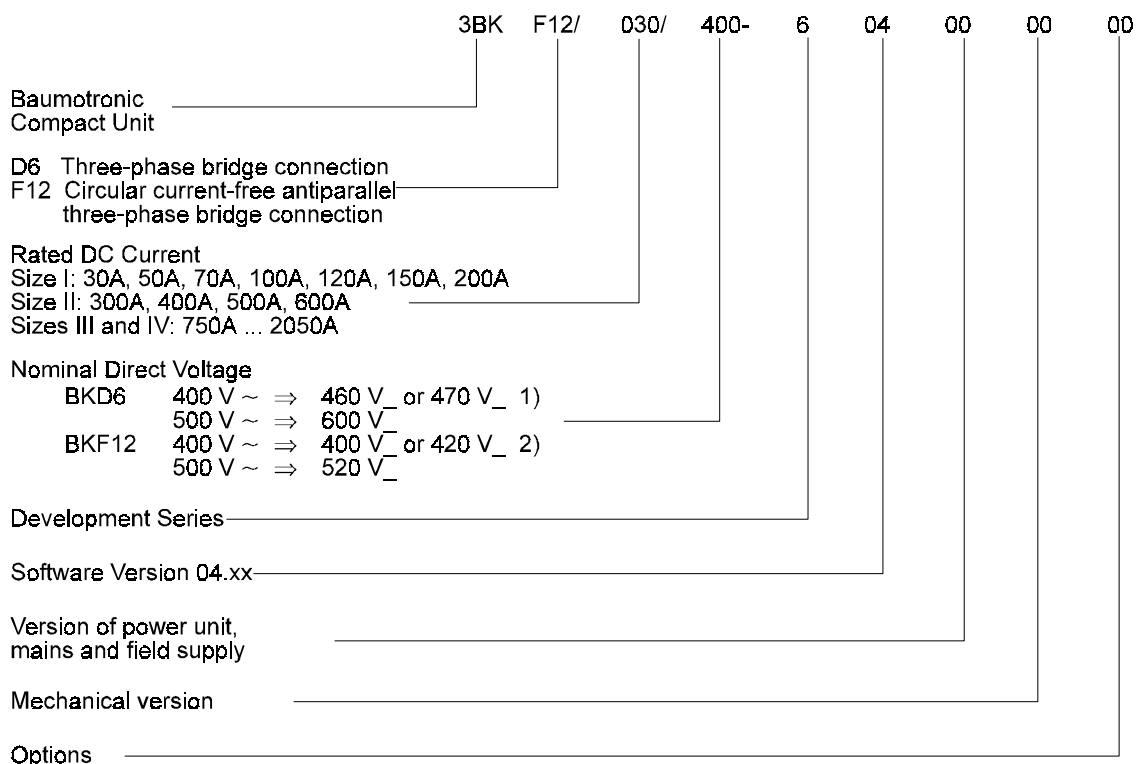

1) 460 V at the original mains voltage of 380 V ±10% or at a mains voltage of 400 V +6%, -15%.
470 V according to DIN 40030/09.93 since the raising of the mains voltage in accordance with DIN IEC 38/05.87 to 400 V +6%, -10%.
The 460-V voltage specification in the type code is retained, even after the raising of the mains voltage, in the interests of uniform type designations.

2) 400 V at the original mains voltage of 380 V ±10% or at a mains voltage of 400 V +6%, -15%.

420 V according to DIN 40030/09.93 since the raising of the mains voltage in accordance with DIN IEC 38/05.87 to 400 V +6%, -10%.
The 400-V voltage specification in the type code is retained, even after the raising of the mains voltage, in the interests of uniform type designations.

2.3 Technical Data of Power Converter Units

	BKD 6/.../460-6000 BKF12/.../400-6000	BKD 6/.../600-6000 BKF12/.../520-6000	
Connection Voltage ²⁾	3 x 400 V	3 x 460 V	3 x 500 V
Permiss. mains voltage tolerance ²⁾	±10%		
Mains Frequency	47 ... 63 Hz		
Nominal DC current acc. to DIN 40030/09.93 ²⁾ BKF ³⁾ BKD	420 V 470 V	480 V 550 V	520 V 600 V
In unit sizes I and II, the graduation of the nominal DC current of BKD6 and BKF12 is the same ¹⁾			
Size I	30 A 50 A 70 A 100 A 120 A 150 A 200 A	Correcting range (P025) 15 A ... 30 A 25 A ... 50 A 35 A ... 70 A 50 A ... 100 A 60 A ... 120 A 75 A ... 150 A 100 A ... 200 A	
Size II	300 A 400 A 500 A 600 A	150 A ... 300 A 200 A ... 400 A 250 A ... 500 A 300 A ... 600 A	
In unit sizes III and IV, the nominal DC currents of BKD6 and BKF12 are different ¹⁾			
Size III (BKD6/.../...-6000)	750 A 920 A 1100 A	375 A ... 750 A 460 A ... 920 A 550 A ... 1100 A	
Size III (BKF12/.../...-6000)	850 A	425 A ... 850 A	
Size IV (BKD6/.../...-6000)	1550 A 1750 A 2050 A	775 A ... 1550 A 875 A ... 1750 A 1025 A ... 2050 A	
Size IV (BKF12/.../...-6000)	1250 A 1400 A 1650 A	625 A ... 1250 A 700 A ... 1400 A 825 A ... 1650 A	
Operating temperature range	Self-ventilated: 30-A unit Force-ventilated: 50-A and above unit		0 ... 45°C 0 ... 35°C
At temperatures up to 55°C	Reduction of the nominal DC current by		1% per °C
At H > 1000 m above sea level	Reduction of the nominal DC current by		10% per 1000 m
Storage & transportation temperature	-30 ... +70 °C		
(Humidity rating acc. to DIN 40440)	(F; power stages of unit sizes III and IV: E)		
Climatic category acc. to EN 60721	3K3		
Type of protection acc. to EN 60529 or DIN VDE 0470-1	IP 00		
Dimensions	Refer to 4.1, Assembly		
Weight	Refer to 4.1, Assembly		
Speed range	> 1:100		

- 1) The nominal DC voltage applies to the stated temperature range up to an altitude of 1000 m above sea level (the permanently permissible nominal DC voltage)
- 2) Refer to 2.11 for the adaptation of power converters to different connection voltages
- 3) Output voltage of the power converters in dependence on delay angle α :

$$U_{di\alpha} = \frac{3 \cdot \sqrt{2}}{\pi} \cdot U_{mains} \cdot \cos \alpha$$

The correcting range of the delay angle α depends on the unit type (BKD or BKF) and on parameters P105: "Nominal mains voltage" and P110: "Armature/Mains voltage".

You can request the limits set in the power converter at any one time using display parameters P111: "Final rectifier position α_G " and P112: "Final inverter position α_W ". You can only change the limits indirectly using parameters P105 and P110 mentioned above.

Example of P105 = 400 V

Unit	BKF + BKD						BKD		
P105 [V]	400 V								
P110	0.8	0.85	0.90	0.95	1.00	1.05	1.10	1.15	1.21
P111 [°]	49	46	42	39	35	30	25	19	10
P112 [°]	150								

2.4 Technical Data of Field Power Converter

	BKD 6/.../460-6000 BKF12/.../400-6000	BKD 6/.../600-6000 BKF12/.../520-6000	
Connection voltage	400 V	460 V	500 V
Perm. mains voltage tolerance	±10%		
Mains frequency	47 ... 63 Hz		
Nominal DC voltage, field ¹⁾	310 V	360 V	390 V
Nominal DC voltages, field	0.5 A 1 A 3 A 4 A 6 A 8 A 10 A 15 A 25 A	Setting range (P049)	0.1 A ... 0.5 A 0.2 A ... 1.0 A 0.6 A ... 2.0 A 0.8 A ... 4.0 A 1.2 A ... 6.0 A 1.6 A ... 8.0 A 2.0 A ... 10.0 A 3.0 A ... 15.0 A 5.0 A ... 25.0 A
With sizes II, III and IV only			
Operating temperature range	0 ... 45 °C		
At temperatures up to 55°C	Reduction of the nominal DC voltage by	1% per °C	
At H > 1000 m above sea level	Reduction of the nominal DC voltage by	10% per 1000 m	
Connection	Up to 15 A nominal DC current inclusive Terminals X2:6-9 on PCB 3.8942 Input voltage at X2:6, 7 in-phase with mains unit X2:1,2 and power stage AK1, AK5 25 A nominal DC current Terminals X3:1-4 (separate terminal strip) Input voltage at X3: 1, 2 in-phase with mains unit X2:1,2 and power stage AK1, AK5		
"Main contactor ON" relay Relay contact can be loaded with	Changeover contact 250 V/1 A or 24 V/1 A, Min. switching capacity: 12 V, 400 mA, 4.8 W Terminals X2:3, 4, 5 (on field and mains unit supply 3.8942)		
Field weakness control	With controller structure P083=1, 3		
Release point	50% to 100% of the nominal armature voltage		
Zero speed field	20% to 100% above parameters P075 and P077		
Timeout for zero speed field	0 to 180 s above parameter P076		
Field failure protection	50% of field current nominal value value		
Field connection monitoring	At switch-on, see parameter P122		
Line reactors	2 x DR1-23-3-003 3 A or 2 x DR1-23-3-008 8 A or 2 x DR1-23-3-015 15 A or 2 x DR1-23-3-025 25 A		
Semiconductor fuses	2 x 5 SD 420, Silized 16 A/500 V, size E27 or 2 x 5 SD 430, Silized 20 A/500 V, size E27 or 2 x 5 SD 440, Silized 25 A/500 V, size E27 or 2 x 5 SD 480, Silized 30 A/500 V, size E27 Mount externally		

¹⁾ Output voltage of the field power converter in dependence on delay angle α:

$$U_{d\alpha} = \frac{2 \cdot \sqrt{2}}{\pi} \cdot U_{mains} \cdot \frac{1 + \cos \alpha}{2}; \quad \alpha = 20 \dots 165^\circ$$

2.5 Technical Data of Mains Unit

2.5.1 Standard Version with Conventional Mains Unit

Type designation of units: BKF 12/ ... - 60400...

BKD 06/ ... - 60400...

	BKD 6/.../460-6000 BKF12/.../400-6000	BKD 6/.../600-6000 BKF12/.../520-6000
Connection voltage ¹⁾	400 V/460 V/500 V, settable using wire bridges (W3, W4 on PCB 3.8942)	
Connection	Terminals X2:1, 2 In-phase with power stage and field (L1/L3)	
Permiss. mains voltage tolerance ¹⁾	-15%/+10%	
Mains frequency	47 ... 63 Hz	
Power demand	50 W	
Fuse	0.4 A medium time lag 500 V external	
Direct voltages For switching inputs Range Reference potential	Terminal X1:20, +24 V/100 mA, non-stabilized 20 V ... 28 V BSE, terminal X1:21 on PCB 3.8934	
Direct voltages Internal for controller Internal for fan	±15 V +5 V 24 V (unit size I 50 A nominal current and above)	

¹⁾ Refer to 2.11 Adapting Power Converters to Different Connection Voltages

2.5.2 Special Version with Switching Mains Unit and External 24-V Supply

Type Designation of the Units: BKF 12/ ... - 60401 ...
 BKD 06/ ... - 60401 ...

	BKD 6/.../460-6000 BKF12/.../400-6000	BKD 6/.../600-6000 BKF12/.../520-6000	
Mains connection voltage ¹⁾	400 V/460 V/500 V, settable using wire bridges (W3, W4 on PCB 3.8942)		
Connection	Terminals X2:1, 2 In-phase with power stage and field (L1/L3)		
Permiss. mains voltage tolerance ¹⁾	200 V ... 440 V	230 V ... 510 V	250 V ... 550 V
Mains frequency	47 ... 63 Hz		
Power demand	10 W ... 50 W, depending on the mains connection voltage level		
Fuse	0.4 A medium time lag 500 V external on X2:1,2		
Direct voltage Range	+24 V 21 V ... 30 V		
Connection	Terminals X34: 1, 2; 1: GND; 2: +24 V isolated, max. potential to electronic ground: 50 V		
Nominal current	With unit fully equipped: maximum of 1.7 A		
Permiss. starting current inrush	50 A		
Limiting	External action necessary, e.g. – Using an external power supply with current limiting – Current limiting by means of a series resistor		
Fuse	Depending on the limiting of the starting current inrush; at $\hat{I} = 50 \text{ A}$: at least 5 A slow-blow acc. to DIN 41571		
Uses	– With automatic restarting after brief mains disturbances – Applications in which the tolerance of the connection voltage exceeds the permissible values of 2.4.1		
Direct voltages For switching inputs Range Reference potential	Terminal X1:20, +24 V/100 mA, non-stabilized 20 V ... 28 V BSE, terminal X1:21 on PCB 3.8934		
Direct voltages Internal for controller	±15 V +5 V		
Internal for fan	24 V (unit size I 50 A nominal current and above)		

¹⁾ Refer to 2.11 Adapting Power Converters to Different Connection Voltages

2.6 Technical Data of Power stage

	BKD 6/.../460-6000 BKF12/.../400-6000	BKD 6/.../600-6000 BKF12/.../520-6000	
Connection voltage ¹⁾	3 x 400 V	3 x 460 V	3 x 500 V
Connection	Phases L1 and L3 identical with mains unit and field AK1, AK3 and AK5, clockwise-rotating field		
Power stage Sizes I, II: Modular thyristor Sizes III, IV: Disk-type thyristor	SKKT .. /12 SKT .. /12	SKKT .. /16 SKT .. /16	SKKT .. /16 SKT .. /16
Permiss. mains voltage tolerance ¹⁾	±10%		
Mains frequency	47 ... 63 Hz		
Fan Size I From 50 A ... 200 A Size II 300 A ... 600 A Size III BKD 6/.../...-6000, 750 A .. 1100 A BKF 12/ / -6000, 850 A Size IV BKD 6/.../...-6000, 1550 A .. 2050 A BKF 12/ / -6000, 1250 A .. 1650 A	24 V/4.5 W/3000 RPM Range: 12 V ₋ ... 28 V ₋ , Internal connection Order No. 19007542 400 V/3 ~/50 Hz/0.23 A/120 W/2680 RPM 400 V/3 ~/60 Hz/0.3 A/180 W/2680 RPM Connection via plug-in contact X100 on fan Order No. 19007543 230 V/1 ~/0.94 A at 50 Hz 400 V/3 ~/1.2 A at 50 Hz		
Current transformer Size I Size II Size III Size IV	50 A/70 mA Order No. 19007313 120 A/70 mA Order No. 19007314 250 A/70 mA Order No. 19007304 400 A/70 mA Order No. 19007300 720 A/70 mA Order No. 19007338 1200 A/70 mA Order No. 19007339 1500 A/70 mA Order No. 19007340		
With unit sizes III and IV only: Fuse monitoring	Terminals X100:1, 2 Contact loading: max. of 250 V~/2 A or 30 V~/2 A, min. of 24 V~/100 mA		

¹⁾ Refer to 2.11 Adapting Power Converters to Different Connection Voltages

2.7 Technical Data of Processor Board 3.8934

Processor	MC 68000
Display	4-digit 7-segment display including sign
Input	Keyboard (PC, controller)
Operating status	10 LEDs
CPU board connections controller PC (RS232)	Terminal block X1, 42-pin Sub-D socket X2, 25-pin
Relay K1 K2 optionally programmable K3 optionally programmable K4 optionally programmable Relay contact can be loaded with max. potential	<ul style="list-style-type: none"> – Ready for operation – Speed $n > n_x$ – Current monitoring – Operating speed reached (n_{nom} at ramp function generator input) – Current monitoring – Speed monitoring – Drive ready to start – Field current monitoring – Operating speed reached (n_{nom} at speed controller input) – Temperature monitoring of power stage and motor or – Drive ON message and temperature monitoring of power stage and motor <p>Max. of 24 V/1 A; min. of 1 V/1 mA 50 V to electronic ground</p>
Switching inputs Low level High level Max. potential Voltage supply Reference potential BSE Main contactor on Controller enable Emergency stop Pulse enable Motor potentiometer RPM ↑ Motor potentiometer RPM ↓ Programmable switching input Programmable switching input	<p>Input open or 0 V, range 0 V ... +5 V +24 V, range +15 V ... +30 V, $R_i = 3 \text{ k}\Omega$ 50 V to electronic ground +24 V/100 mA, terminal X1:20</p> <p>X1:21 X1:22 X1:23 X1:24 X1:25 X1:26 X1:27 X1:28 X1:29</p>

<p>Programmable input Input resistance</p> <p>As an analog input</p> <ul style="list-style-type: none"> - various current limits for both torque directions - Analog specification of the field current nominal value value <p>As a switching input</p> <ul style="list-style-type: none"> - Low level - High level - Hysteresis - Polarity reversal of nominal value value - Nominal value multiplication - Nominal value zeroing before/after nominal value integrator - Ramp function generator stop - On/stop simulation - Quick starting 	<p>X1:9 to X1:10 (BSA); Parameter P084= 0 ... 13 55 kΩ</p> <p>-10 V ... 0 V ... +10 V</p> <p>P084=1, 2, 3, 10, 11</p> <p>P084=8</p> <p>Input open or 0 V, range 0 V ... +5 V +24 V, range +7.5 V ... +30 V Approximately 5 V</p> <p>P084=5 P084=4</p> <p>P084=6, 7 P084=9 P084=12 P084=13</p>
<p>Speed nominal value source</p> <p>Analog nominal value 1 (P080=1) Adaptation Limiting Input</p> <p>Analog nominal value 2 (P080=2) Adaptation Limiting Input</p> <p>Nominal value 3 (P080=3) Limiting</p> <p>Nominal value 4 (P080=4) Connection Specification</p> <p>Nominal value 5 (P080=5) Value Time</p> <p>Nominal value 6 (P080=6) Inching function</p> <p>Nominal value 7 (P080=7) Inching function</p> <p>Nominal value 8 (P080=8)</p> <p>Nominal value 9 (P080=9)</p> <p>Nominal value 10 (P080=10) Lower value Upper value Ramp-up time Ramp-down time Memory value Display of function</p>	<p>Parameter P080 = 1 ... 16</p> <p>0 ... ±10 V, + for clockwise rotation Potentiometer R100 ±100% Difference amplifier, terminals X1:7 and 8, R_i=55kΩ</p> <p>0 ... ±10 V, + for clockwise rotation Parameter P113, P114 ±100% Summing amplifier, terminals X1:3 and 5, R_i=55kΩ Reference potential BSA X1:4 and X1:6</p> <p>Σ from nominal value 1 and nominal value 2 ±100%</p> <p>0 ... ±100%, serial, parameter P050 Sub-D socket X2 or daughterboard PC or controller</p> <p>Square-wave generator, internal -100.0 ... +100.0; parameters P090 and P091 0.1 ... 100 s, parameters P092 and P093</p> <p>-100.0% ... +100.0%, parameter P051 X1:28, parameter P099=1</p> <p>-100.0% ... +100.0%, parameter P052 X1:29, parameter P099=1</p> <p>-100.0% ... +100.0%, parameter P053</p> <p>-100.0% ... +100.0%, parameter P054</p> <p>Motor potentiometer function, internal -100.0% ... +99.9%, parameter P056 -99.9% ... +100.0%, parameter P055 0.1 s ... 100.0 s, parameter P057 (850 s from S04.27 onwards) 0.1 s ... 100.0 s, parameter P058 (850 s from S04.27 onwards) Any Via parameter P108</p>

<p>Nominal value 11 (P080=11)</p> <p>Nominal value 12 (P080=12)</p> <p>Nominal value 13 (P080=13)</p> <p>Nominal value 14 (P080=14)</p> <p>Nominal value 15 (P080=15)</p> <p>Nominal value 16 (P080=16)</p> <p>Nominal value voltage stable</p> <p>Internal resistance</p>	<p>Nominal value setting via dual-port RAM without protocol (with InterBus-S daughterboard 3.9208 only)</p> <p>15-bit twos complement parallel nominal value setting (with daughterboard 3.9217 only)</p> <p>14-bit and sign parallel nominal value setting (with daughterboard 3.9217 only)</p> <p>14-bit with sign parallel nominal value setting, decimal nominal value setting (with daughterboard 3.9217 only)</p> <p>Additive linking of nominal value sources 2 and 4</p> <p>As with nominal value 3; nominal value 1 is routed directly to the speed governor; nominal value 2 is routed via the ramp function generator</p> <p>-10 V/10 mA, terminal X1:19 +10 V/10 mA, terminal X1:17 BSA, terminal X1:18</p> <p>100 Ω</p>																					
<p>Speed actual value</p> <p>With tachometer control</p> <p>Input</p> <p>Adaptation</p> <p>Value</p> <p>Component fitted ex-works</p> <p>With e.m.f. control</p> <p>Adaptation</p> <p>With speed control with incremental encoder input</p>	<p>Terminals X1:1 and X1:2</p> <p>Potentiometer R103 and tachometer series resistor R102, 2 W, 2%, TK25</p> <table border="1" data-bbox="608 1010 1358 1128"> <thead> <tr> <th>R102</th> <th>6.8k</th> <th>10k</th> <th>15k</th> <th>22k</th> <th>27k</th> <th>33k</th> </tr> </thead> <tbody> <tr> <td>Tachom. voltage</td> <td>25 V..</td> <td>40 V..</td> <td>60 V..</td> <td>80 V..</td> <td>100 V..</td> <td>120 V..</td> </tr> <tr> <td>U_T at n_{max}</td> <td>.. 50 V</td> <td>.. 80 V</td> <td>..110 V</td> <td>..150 V</td> <td>..200 V</td> <td>..230 V</td> </tr> </tbody> </table> <p>10 kΩ if the power converter cannot be preset due to missing motor and tachometer data.</p> <p>P082, P110</p> <p>Alternatively, daughterboard from</p> <ul style="list-style-type: none"> - InterBus-S 3.9208 - Input/output expansion card 3.9217 - CS31/USS 3.9493 <p>Adaptation via P142, P143, P144</p>	R102	6.8k	10k	15k	22k	27k	33k	Tachom. voltage	25 V..	40 V..	60 V..	80 V..	100 V..	120 V..	U_T at n_{max}	.. 50 V	.. 80 V	..110 V	..150 V	..200 V	..230 V
R102	6.8k	10k	15k	22k	27k	33k																
Tachom. voltage	25 V..	40 V..	60 V..	80 V..	100 V..	120 V..																
U_T at n_{max}	.. 50 V	.. 80 V	..110 V	..150 V	..200 V	..230 V																
<p>Analog outputs</p> <p>Armature current actual value</p> <p>Standardization</p> <p>Output</p> <p>Measuring channel 1</p> <p>Test point</p> <p>Resolution</p> <p>Connection</p> <p>Measuring channel 2</p> <p>Test point</p> <p>Resolution</p> <p>Scaling</p> <p>Connection</p>	<p>0 ... +10 V/4 mA, $R_i = 100 \Omega$; decoupled compliance voltage 10 V corresponds to unit's rated current (at P025 = 1.00)</p> <p>Terminals X1:15 and X1:16 (BSA)</p> <p>0 ... ±10 V/4 mA, $R_i = 100 \Omega$</p> <p>Refer to parameter P088</p> <p>7-bit (approx. 150 mV)</p> <p>Terminals X1:11 and X1:12 (BSA)</p> <p>0 ... ±10 V/4 mA, $R_i = 100 \Omega$</p> <p>Refer to parameter P089</p> <p>7-bit (approx. 150 mV)</p> <p>0.20 ... 1.00 (P125), 0.20 ... 2.00 from S04.30 onwards</p> <p>Terminals X1:13 and X1:14 (BSA)</p>																					

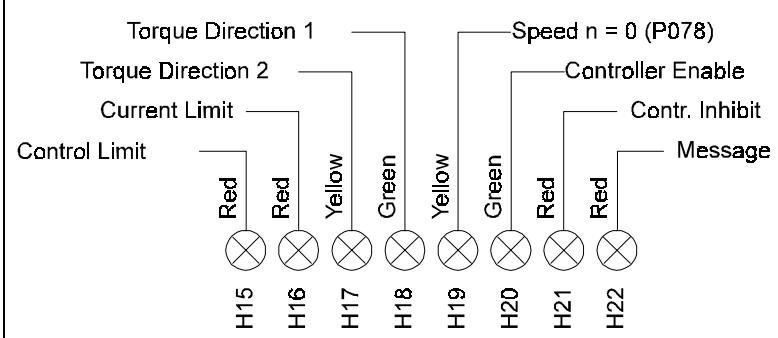
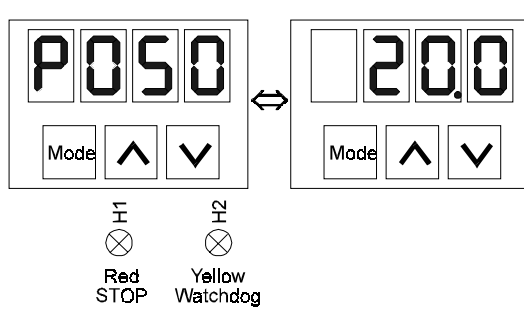
<p>Analog outputs</p> <p>Measuring channel 3 Test point Resolution Connection</p> <p>Measuring channel 4 Test point Resolution Scaling Connection</p>	<p>Measuring channels 3 and 4 with daughterboard only, choice from – Dual DAC 12, 3.9201 – Input/output expansion card 3.9217</p> <p>0 ... ±10 V/4 mA, $R_i = 100 \Omega$ Refer to parameter P130 11-bit (approx. 10 mV) Depending on the daughterboard used</p> <p>0 ... ±10 V/4 mA, $R_i = 100 \Omega$ Refer to parameter P131 11-bit (approx. 10 mV) 0.20 ... 1.00 (P132), 0.20 ... 2.00 from S04.30 onwards Depending on the daughterboard used</p>
<p>Display of operating status conditions/error messages</p>	<p>LED displays</p>  <p>Control Limit Current Limit Torque Direction 2 Torque Direction 1 Speed n = 0 (P078) Controller Enable Contr. Inhibit Message</p> <p>H15 H16 H17 H18 H19 H20 H21 H22</p> <p>Display and Keypad</p>  <p>H1 H2 Red STOP Yellow Watchdog</p>

2.8 Technical Data of Supplementary Modules

As an option, you can fit several different daughterboards on the CPU board, which have the following functions:

2.8.1 "Dual DAC 12", Daughterboard 3.9201

Additional measuring channels 3 and 4

Measuring channel 3 Test point Resolution Connection	0 ... ±10 V/4 mA, R _i = 100 Ω Refer to parameter P130 11-bit (approx. 10 mV) Terminals X4:1 and X4:2 (BSA)
Measuring channel 4 Test point Resolution Scaling Connection	0 ... ±10 V/4 mA, R _i = 100 Ω Refer to parameter P131 11-bit (approx. 10 mV) 0.20 ... 1.00 (P132), 0.20 ... 2.00 from S04.30 Terminals X4:3 and X4:4 (BSA)
Assembly	By means of a 22-mm spacer bolt on CPU card 3.8934 and 64-pin ribbon cable X15

2.8.2 "Input/Output Expansion", Daughterboard 3.9217

Incremental encoder input for speed measurement Alternatively Incremental encoder with +5-V supply for two 90° phase-shifted differential impulses Signal level Connection	– Differential input – Power supply of encoder possible from daughterboard LOW signal: 0 ... +0.45 V HIGH signal: +2.4 V ... +5.25 V Sub-D socket 15-pin X7A
Incremental encoder with +24-V supply for two 90° phase-shifted differential impulses Signal level Connection	– Isolated via optocoupler – Power must be supplied to encoder externally LOW signal: 0 ... +4 V HIGH signal: +15 V ... +30 V R _i = 3 kΩ Terminal block X7B:15-17
Encoder selection via jumpers Speed range No. of incr. encoder graduations Maximum frequency Polarity reversal Achievable maximum speed	W1 and W2 P142: 100 ... 6000 min ⁻¹ P143: 250 ... 4096 300 kHz P144: on, off $n_{\text{nom}}[\text{RPM}] = \frac{60 \cdot 300}{\text{Pulse number}} \cdot 1000$

Two additional measuring channels	
Measuring channel 3 Test point Resolution Connection	0 ... ±10 V/4 mA, $R_i = 100 \Omega$ Refer to parameter P130 11-bit (approx. 10 mV) Terminals X7B:2 and X7B:1 (BSA)
Measuring channel 4 Test point Resolution Scaling Connection	0 ... ±10 V/4 mA, $R_i = 100 \Omega$ Refer to parameter P131 11-bit (approx. 10 mV) 0.20 ... 1.00 (P132), 0.20 ... 2.00 from S04.30 Terminals X7B:4 and X7B:3 (BSA)
Digital parallel nominal value setting Signal level Connection Nominal value source	– Isolated via optocoupler – Max. potential to electronic ground: 50 V LOW signal: 0 ... +4 V HIGH signal: +15 V ... +30 V $R_i = 3 \text{ k}\Omega$ Terminal block X7B:21-38 Parallel nominal value setting P080=12: 15-bit twos complement P080=13: 14-bit and sign P080=14: 12-bit and sign, decimal nominal value settings
Digital outputs Connection Signals	– Isolated via optocoupler – Loadable with 35 V/100 mA – Max. potential to electronic ground: 50 V Terminal block X7B:5-14 DA0: Loaded data set DA1: Loaded data set DA2: Loaded data set DA3: Not assigned DA4: Not assigned DA5: Not assigned DA6: Not assigned DA7: Frequency message
Assembly	By means of a 22-mm spacer bolt on CPU card 3.8934 and 64-pin ribbon cable X15

2.8.3 InterBus-S Interface Board, 3.9208

With incremental encoder acquisition for speed actual value formation

InterBus-S interface

Processor	80C32
ASIC	SμPI
Isolation INTERBUS-S/controller Within the local bus	500 V AC/VDE 0160 None
Power supply External Internal	Bus terminal Power converter unit
Transfer rate	300 kbps
Length of remote bus from node to node maximum	100 m/400 m* 12.8 km
Length of local bus from drive to drive maximum	1.5 m 6 m/10 m*
Number of drives or I/O modules	4/8 on one bus terminal (node)
Operation indicators	5 LEDs: H1 Yellow Message H2 Red PCP error H3 Green Online H4 Red Reset H5 Green 5-V supply
Connection	Local bus input: Sub-D plug X8B, 15-pin Local bus output: Sub-D socket X8C, 15-pin

You can obtain detailed documentation about the InterBus-S bus system** from the Phoenix Contact company in D-32819 Blomberg, Germany.

* The data applies to bus terminals IBS 220 BK or IBS 24 BK.

** InterBus-S is a registered trademark of Phoenix Contact.

Incremental encoder input for speed measurement

Incremental encoder with +5-V supply for two 90° phase-shifted differential impulses	– Differential input – Power supply of encoder possible from daughterboard
Signal level	LOW signal: 0 ... +0.45 V HIGH signal +2.4 V ... +5.25 V
Connection	Sub-D socket, 15-pin. X8D
Speed range	P142: 100 ... 6000 RPM
No. of incr. encoder graduations	P143: 250 ... 4096
Maximum frequency	300 kHz
Polarity reversal	P144: on, off
Achievable maximum speed	$n_{nom}[RPM] = \frac{60 \cdot 300}{\text{Pulse number}} \cdot 1000$
Assembly	By means of a 22-mm spacer bolt on CPU card 3.8934 and 64-pin ribbon cable X15

For further details, refer to the additional description.

2.8.4 RS232, RS485 Interface Card, 3.8947

Task	RS232, RS485 interface card \Leftrightarrow power converter BKF/BKD		
CPU	μ P 68008		
Clock frequency	8 MHz		
Memory	64 kB ROM 32 kB RAM		
Software version interface card	01.12		
Transfer rate	1200 ... 38400 bps		
Bus system	RS485	RS232	TTY
Line length	400 m	20 m	5 m
Potential, between bus and card	150 V _{eff} (max.)		
Voltage supply on bus side at X1:1, 2 voltage	Typically 300 mA 24 V ₋		
Voltage supply of interface card	Via X15 from power converter		
Maximum current loading of connections X3 and X4	Total of 50 mA		
Connections X1: 24-V supply X2: RS232 X3: RS485 X4: RS485 X5: Test plug X15: Ribbon cable to the power converter	Via terminals Via 15-pin Sub-D socket Via 9-pin Sub-D socket Via 9-pin Sub-D plug For functional testing in the factory only		
Assembly	By means of a 22-mm spacer bolt on CPU card 3.8934 and 64-pin ribbon cable X15		

For further details, refer to the additional description.

2.8.5 RS485 with USS Protocol or as a CS31 System Bus Interface, 3.9493

With incremental encoder acquisition for speed actual value formation

Bus interface

	USS	CS31
Processor	80C32	
Isolation	Via optocoupler, 50 V to electronic ground	
Power supply Processor side Bus side	Power converter Power converter via DC/DC converter	
Interface standard	RS485	
Transfer rate	9600, 19200 bps	
Line length	Maximum of 400 m	
Operation indicators	H101 Yellow: No message frame received for more than 1 s H102 Red: Bus interrupted H103 Green: Communication with power converter ongoing	H101 Yellow: Monitoring time-out for bus communication has expired H102 Red: Disturbance H103 Green: Communication with power converter ongoing H401 Red: Remote Unit Error H402 Green: CS31 system running
Connections	RS485: X601, X602 X601: 9-pin SUB-D plug X602: 9-pin SUB-D socket	

Incremental encoder input for speed measurement

Incremental encoder with +5-V supply for two 90° phase-shifted differential impulses Signal level Connections Speed range No. of incr. encoder graduations Maximum frequency Polarity reversal Achievable maximum speed	– Differential input – Power supply of encoder possible from daughterboard LOW signal: 0 ... +0.45 V HIGH signal +2.4 V ... +5.25 V X8: 15-pin SUB-D socket X9: 15-pin SUB-D plug P142: 100 ... 6000 RPM P143: 250 ... 4096 300 kHz P144: on, off $n_{nom}[RPM] = \frac{60 \cdot 300}{\text{Pulse number}} \cdot 1000$
Assembly	By means of a 22-mm spacer bolt on CPU card 3.8934 and 64-pin ribbon cable X15

For further details, refer to the additional description.

2.9 Power Loss of Power Converter, Line Converter and Fuses

When using the additional components (line converter, semiconductor fuses) listed in chapter 4, the power losses shown below result at the equipment's nominal working point:

Power Converter BKD or BKF	Nominal Current	Power Losses					
		Unit *	Line Converter	Fuses **		Total	
				BKD	BKF	BKD	BKF
Size I:							
BK ../30	30 A	120 W	40 W	15 W	35 W	175 W	195W
BK ../50	50 A	195 W	55 W	30 W	50 W	280 W	300 W
BK ../70	70 A	290 W	60 W	50 W	85 W	400 W	435 W
BK ../100	100 A	340 W	90 W	45 W	80 W	475 W	510 W
BK ../120	120 A	380 W	100 W	50 W	85 W	530 W	565 W
BK ../150	150 A	420 W	105 W	55 W	125 W	580 W	650 W
BK ../200	200 A	590 W	120 W	90 W	190 W	800 W	900 W
Size II							
BK ../300	300 A	850 W	170 W	85 W	185 W	1100 W	1200 W
BK ../400	400 A	1170 W	180 W	185 W	310 W	1530 W	1660 W
BK ../500	500 A	1250 W	200 W	145 W	280 W	1590 W	1730 W
BK ../600	600 A	1550 W	300 W	195 W	350 W	2050 W	2200 W
Size III							
BKD 6/750	750 A	2700 W	350 W	380 W		3430 W	
BKD 6/920	920 A	2900 W	370 W	410 W		3680 W	
BKD 6/1100	1100 A	3600 W	400 W	550 W		4550 W	
BKF 12/850	850 A	2550 W	360 W		310 W		3220 W
Size IV							
BKD 6/1550	1550 A	4450 W	***	730 W			
BKD 6/1750	1750 A	5700 W	***	750 W			
BKD 6/2050	2050 A	5750 W	***	920 W			
BKF 12/1250	1250 A	3550 W	***		510 W		
BKF 12/1400	1400 A	4500 W	***		640 W		
BKF 12/1250	1650 A	4400 W	***		710 W		

* The power loss of the power converter includes the losses of the power stage for armature and field supply as well as electronics supply.

** In the case of unit sizes I and II, you must arrange the mains semiconductor protective fuses (phase fuses) outside the power converter in the control cabinet. In addition, with the BKF you must also take into account the armature circuit fuses. Unit sizes III and IV have arm-circuit fuses that are already integrated in the equipment.

The chapter entitled Installation contains, to some extent, a choice of two types of fuses. The stated power loss refers to the type with the higher losses, i.e. if you use the other fuse, the power loss is more favourable.

*** On request

2.10 Construction Drawings

2.10.1 CPU Board 3.8934

- PCB Version 3.8934 C

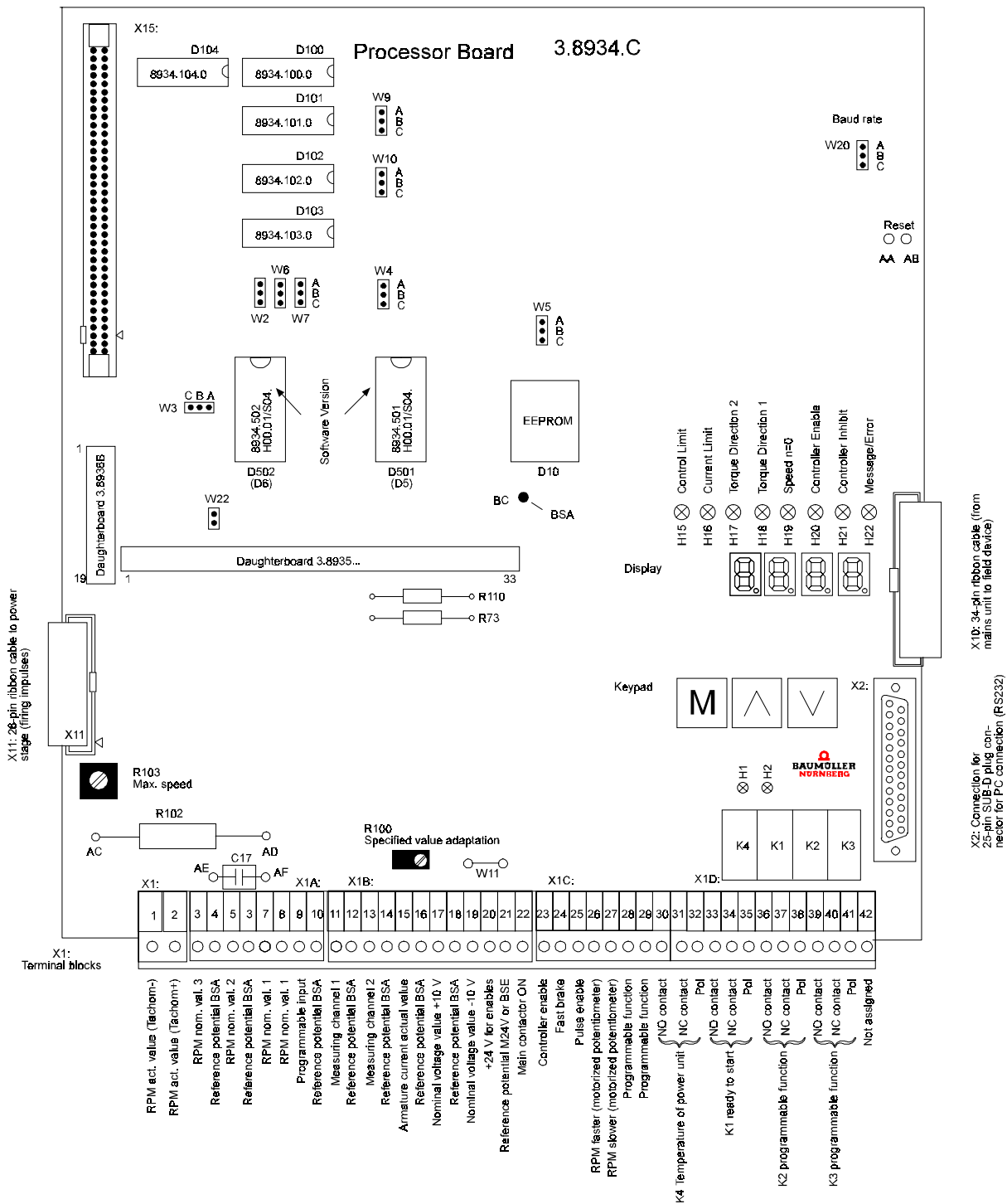

Internal Functions:

Plug-in jumpers: W2: A-B
 W3: A-B
 W4: B-C
 W5: B-C
 W6: A-B
 W7: A-B
 W9: A-B
 W10: A-B
 W20: B-C (baud rate 9600 bps)
 W22: Fitted

Resistors on solder tags: R73: R_V for power stage identification
 R110: R_V for power stage temperature

Soldering jumper W11: Reference point for control inputs X1:22 ... 29
 –fitted if the unit's +24 V is used for controlling the power converter
 – not fitted if the external controller carries out direct control.
 In this case, terminal X1:21 (BSE) is the reference potential.
 – The jumper is fitted in the factory

Condenser C17: 0.47 μ F
 Low pass filter in n_{act} measurement with speed control via tachometer generator.

Resistor R102: Series resistor for adapting the tachometer voltage of the electronics (controller structure P083 = 0 or 1).

R102	6.8k	10k	15k	22k	27k	33k
Tachom. voltage U_T at n_{max}	25 V.. .. 50 V	40 V.. .. 80 V	60 V.. .. 110 V	80 V.. .. 150 V	100 V.. .. 200 V	120 V.. .. 230 V

Potentiometer R103: Fine-tuning the maximum speed

Potentiometer R100: Nominal value adaptation with nominal value source P080 = 1, 3, 16. Only affects the differential gain input (gain: 0.9 ... 2.0)

Solder tags AA-AB: Jumpering results in a hardware reset.

NOTE

You must only specify a reset for the power converter when the controller is disabled **and** the motor is idle.

Solder tag BC Device-internal reference point BSA, e.g. for measurements.

• PCB Version 3.8934 E

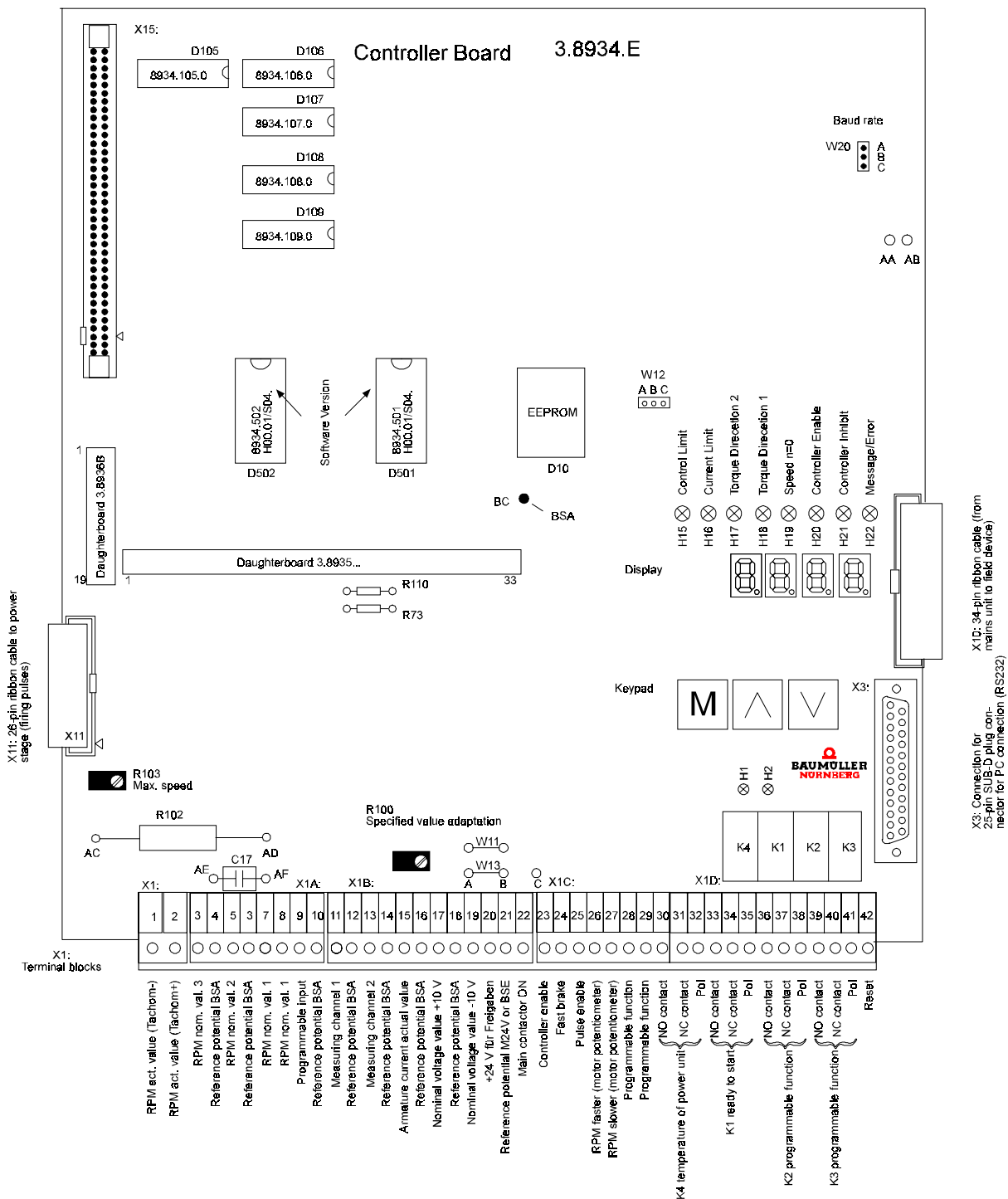

Resistors on solder tags: R73: R_v for power stage identification
 R110: R_v for temperature determination

Solder tags AA-AB: Open, do not connect!

NOTE

With PCB 3.8934.C you could trigger a hardware reset via solder tags AA-AB without switching off the unit. This is not allowed with PCB version 3.8934.E. In this case, a hardware reset is activated by applying +24 V at terminal X1:42 (this terminal was not assigned in PCB version 3.8934.C). You must only specify a reset for the power converter when the controller is disabled **and** the motor is idle.

Soldering jumper W11: Reference point for control inputs X1:22 ... 29
 – fitted if the unit's +24 V is used for controlling the power converter
 – not fitted if the external controller carries out direct control.
 In this case, terminal X1:21 (BSE) is the reference potential
 – The jumper is fitted in the factory

Soldering jumper W13: Specification of the reference point for control input X1:25 (pulse enable)

- Tag A-B selects the reference point that is to be specified with W11 for the other control inputs (fitted in the factory)
- Tag B-C connects the reference point permanently to the device-internal reference ground (M24V). If there is a break in the signal/a voltage failure, this prevents the deletion of the firing pulses in the higher-level controller

Resistor R102: Series resistor for adapting the tachometer voltage of the electronics (controller structure P083 = 0 or 1).

R102	6.8k	10k	15k	22k	27k	33k
Tachom. voltage U _T at n _{max}	25 V.. .. 50 V	40 V.. .. 80 V	60 V.. .. 110 V	80 V.. .. 150 V	100 V.. .. 200 V	120 V.. .. 230 V

Condenser C17: 0.47 µF
 Low pass filter in n_{act} measurement with speed control via tachometer generator.

Potentiometer R103: Fine-tuning the maximum speed

Potentiometer R100: Nominal value adaptation with nominal value source P080 = 1, 3, 16. Only affects the differential gain input (gain: 0.9 ... 2.0)

Solder tag BC Device-internal reference point BSA, e.g. for measurements.

2.10.2 Field Supply 3.8942

- PCB Version up to 3.8942 C inclusive

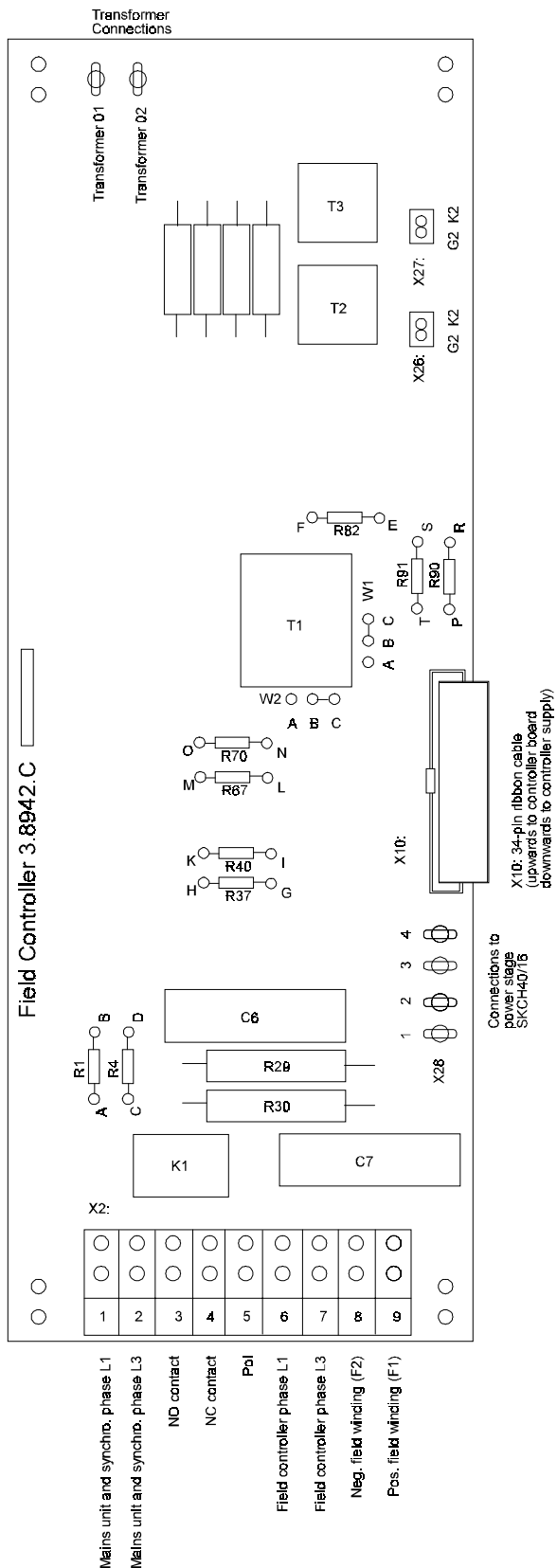

Transformer conns.:	Transformer 01, transformer 02 400 V connection voltage: Transformer Order No. 19007175 500 V connection voltage: Transformer Order No. 19007178
R1, R2:	Input resistors for acquiring the connection voltage for the mains unit
R37, R40:	Input resistors for acquiring the field voltage (AC side)
R67, R70:	Input resistors for acquiring the field voltage (DC side)
R82:	Load impedance for matching the field unit rated current
W1, W2:	Specification of the field current range [0.5 .. 4 A, 5 ... 10 A]

• PCB Version 3.8942 E

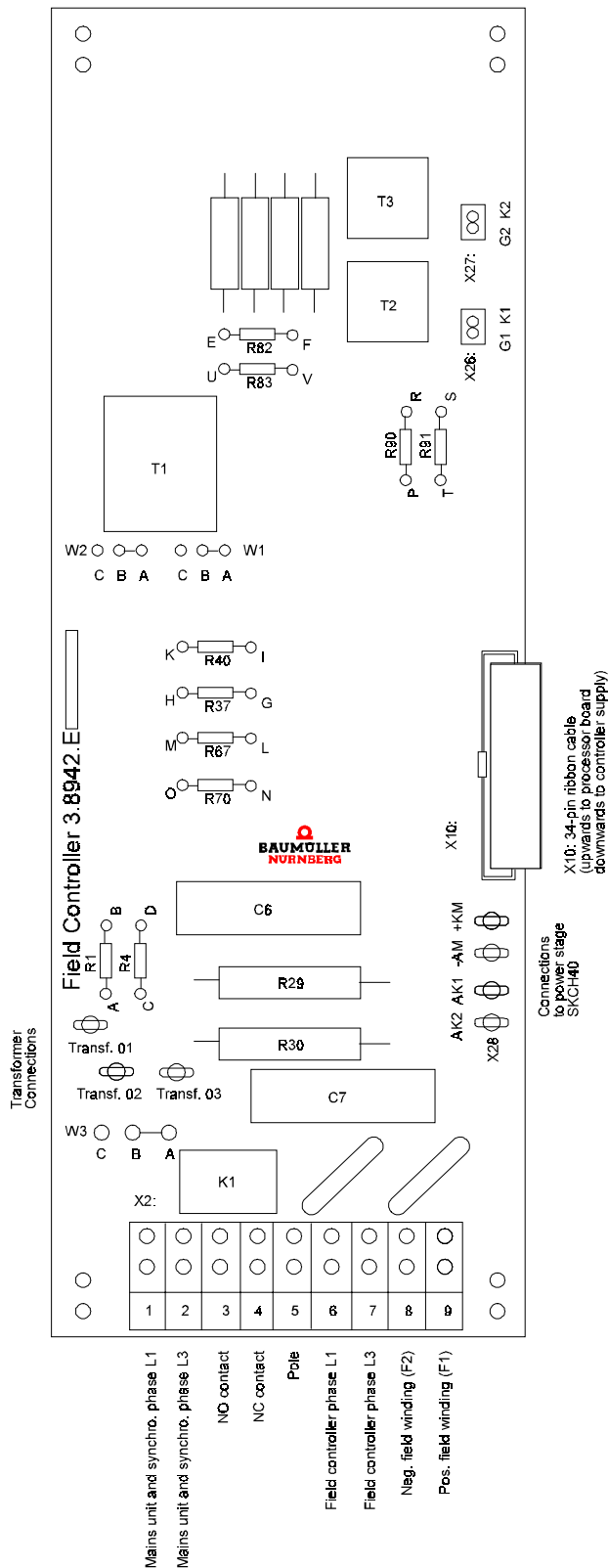

W3:	Mains voltage adaptation
A-B:	500 V mains
C-B:	400 V mains
Transformer conns.:	Transformer 01: 0 V black
	Transformer 02: 400 V blue
	Transformer 03: 500 V brown
	Transformer Order No. 19007178
R1, R2:	Input resistors for acquiring the connection voltage for the mains unit
R37, R40:	Input resistors for acquiring the field voltage (AC side)
R67, R70:	Input resistors for acquiring the field voltage (DC side)
R82, R83:	Load impedance for matching the field unit rated current
W1, W2:	Specification of the field current range [0.5 .. 4 A, 5 ... 10 A]

- PCB Version 3.8942 F

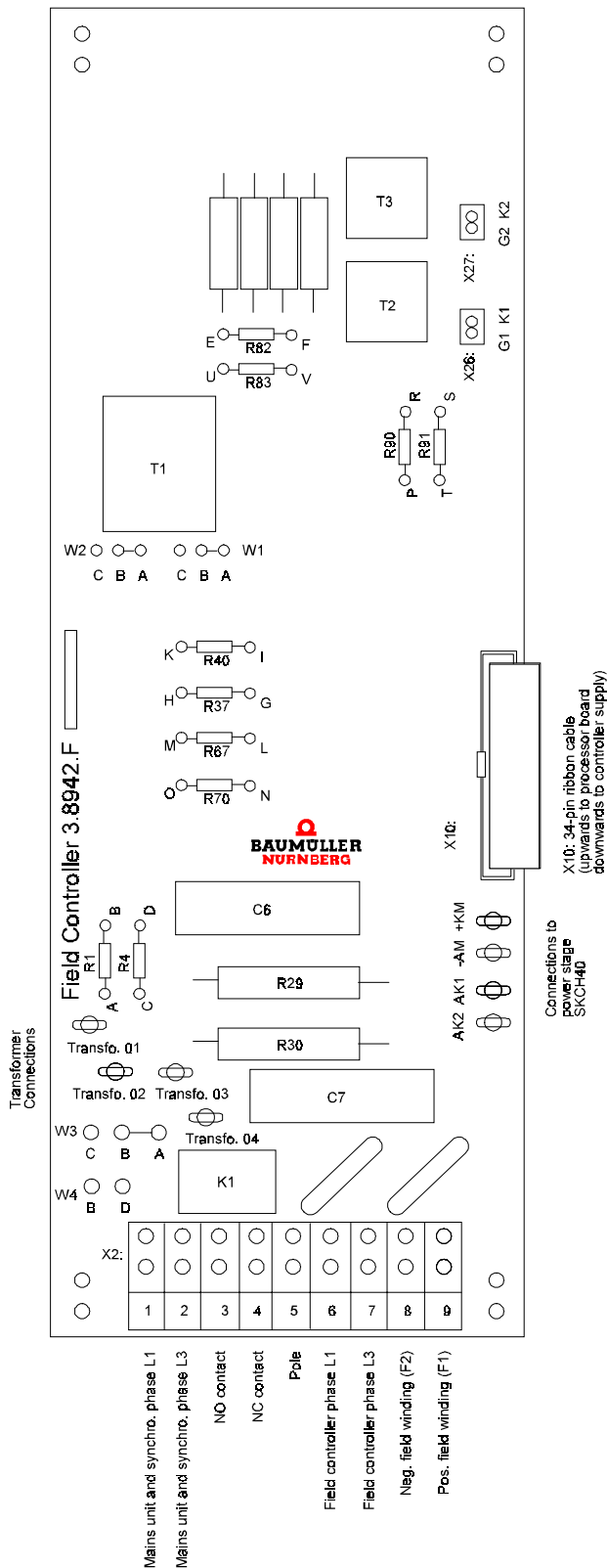

W3, W4:	Mains voltage adaptation		
	W3:	B-C:	400 V mains
	W3:	A-B:	500 V mains
	W4:	B-D:	460 V mains
Transformer conns.:	Transformer 01:	0 V	black
	Transformer 02:	400 V	blue
	Transformer 03:	500 V	brown
	Transformer 04:	460 V	green
	Transformer Order No. 19007183		
R1, R2:	Input resistors for acquiring the connection voltage for the mains unit		
R37, R40:	Input resistors for acquiring the field voltage (AC side)		
R67, R70:	Input resistors for acquiring the field voltage (DC side)		
R82, R83:	Load impedance for matching the field unit rated current		
W1, W2:	Specification of the field current range [0.5 .. 4 A, 5 ... 10 A]		

- PCB Version 3.8942 K

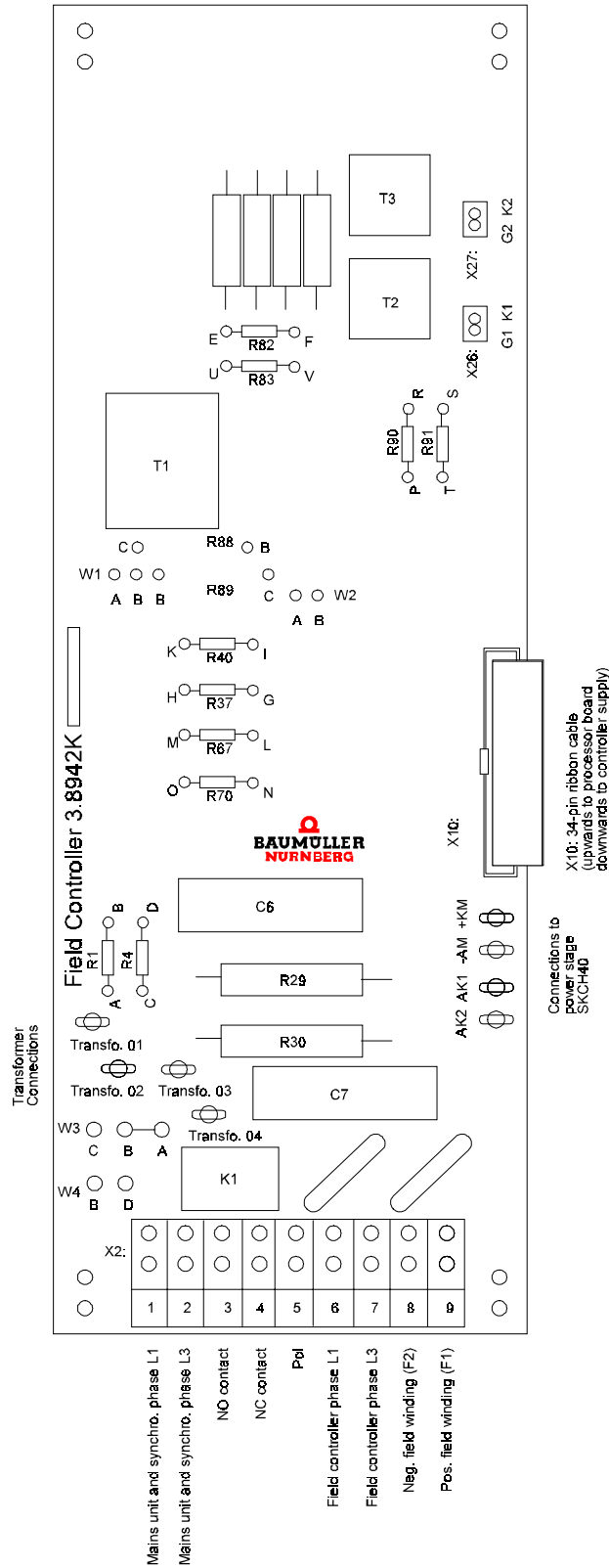

W3, W4:	Mains voltage adaptation		
	W3:	B-C:	400 V mains
	W3:	A-B:	500 V mains
	W4:	B-D:	460 V mains
Transformer conns.:	Transformer 01:	0 V	black
	Transformer 02:	400 V	blue
	Transformer 03:	500 V	brown
	Transformer 04:	460 V	green
	Transformer Order No. 19007183		
R1, R2:	Input resistors for acquiring the connection voltage for the mains unit		
R37, R40:	Input resistors for acquiring the field voltage (AC side)		
R67, R70:	Input resistors for acquiring the field voltage (DC side)		
R82, R83:	Load impedance for matching the field unit rated current		
W1, W2, R88, R89:	Components for specification of the field current range [0.5 .. 4 A, 5 ... 10 A, 15 A, 25 A]		

2.11 Adapting Power Converters to Different Connection Voltages

	Power Demand	220 V ±10%	230 V +6% -15%	230 V ±10%	220 V ±10%	230 V +6% -15%	230 V ±10%
Nominal direct voltage * BKD 6 /... 6000		260 V	260 V	275 V	460 V	460 V	460 V
Nominal direct voltage * BKF 12 /... 6000		230 V	230 V	240 V	400 V	400 V	400 V
Field weakening control unit ** 3.8942		400-V version Bridge W3: B-C					
Power stage ***		400-V version					
Mains unit ***	≈ 50 VA	No adaptation necessary					
Fan: Size I: 30 A 50 A ... 200 A	Unventilated 24 V/4.5 W supplied internally	No adaptation necessary					
Size II: 300 A ... 600 A	400 V/3 -/50 Hz/0.23 A/120 W	By means of an autotransformer					
Size III: BKD: 750 A ... 1100 A BKF: 850 A	230 V/1 -/50 Hz/0.94 A	No adaptation necessary					
Size IV: BKD: 1550 A ... 2050 A BKF: 1250 A ... 1650 A	400 V/3 -/50 Hz/1.2 A	By means of an autotransformer					
Parameters: P105: Rated mains voltage P110: Rated armature/mains volt. * BKD BKF		220 V 1.21 1.05	220 V 1.21 1.05	230 V 1.21 1.05	400 V 1.21 1.05	400 V 1.21 1.05	400 V 1.21 1.05
Miscellaneous		Possible only with special version of unit with switch- ing power supply and ex- ternal 24-V supply			Possible only with a trans- former for the power and mains units (220 V to 400 V and 230 V to 400 V respec- tively)		

* Maximum permissible values relative to the lower tolerance level

** The field supply may be connected to another mains supply with a different voltage if it can be guaranteed that the phase relation to the other mains connections is correct on the power converter (refer to the connection suggestion). Observe the field voltage of the motor!

*** The power stage and the mains unit must be connected to the same mains supply taking into account the phase relation.

	380 V ±10%	400 V +6% -15%	400 V ±10%	415 V +6% -15%	415 V ±10%	440 V ±10%	460 V ±10%	500 V ±10%
Nominal direct voltage * BKD 6 /... 6000	460 V	460 V	485 V	485 V	500 V	530 V	550 V	600 V
Nominal direct voltage * BKF 12 /... 6000	400 V	400 V	420 V	420 V	435 V	460 V	480 V	520 V
Field weakening control unit ** 3.8942	400-V version Bridge W3: B-C				500-V version Bridge W4: B-D			Bridge W3: A-B
Power stage ***	400-V version				500-V version			
Mains unit ***	No adaptation necessary							
Fan: Size I: 30 A 50 A ... 200 A	No adaptation necessary							
Size II: 300 A ... 600 A	No adaptation				By means of an autotransformer			
Size III: BKD: 750 A ... 1100 A BKF: 850 A	By means of an autotransformer							
Size IV: BKD: 1550 A ... 2050 A BKF: 1250 A ... 1650 A	No adaptation				By means of an autotransformer			
Parameters: P105: Rated mains voltage P110: Rated armature/mains volt. * BKD BKF	380 V 1.21 1.05	380 V 1.21 1.05	400 V 1.21 1.05	400 V 1.21 1.05	415 V 1.21 1.05	440 V 1.21 1.05	460 V 1.21 1.05	500 V 1.21 1.05
Miscellaneous					****			

* Maximum permissible values relative to the lower tolerance level

** The field supply may be connected to another mains supply with a different voltage if it can be guaranteed that the phase relation to the other mains connections is correct on the power converter (refer to the connection suggestion). Observe the field voltage of the motor!

*** The power stage and the mains unit must be connected to the same mains supply taking into account the phase relation.

**** Possible only with the special version of the unit with switching power supply and external 24-V supply

3 TRANSPORTATION AND UNPACKING

The equipment is packed at the factory in accordance with the order.

You should avoid jolting or dropping the package during transportation.

You can start assembly after unpacking the equipment and checking that it is complete and undamaged.

The equipment is packed in cardboard, corrugated sheeting and or wooden packaging material that you should dispose of in accordance with local regulations.

Report any damage in transit immediately.

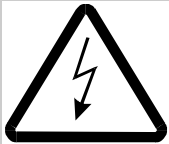

DANGER

If the equipment was damaged in transit, a qualified person must check, repair and test it before it may be connected.

Ignoring this information can result in death, serious injury or considerable damage to property.

4 ASSEMBLY



WARNING

You are responsible for mounting the described equipment, the motor, the commutating reactor and the other equipment in accordance with appropriate safety regulations (e.g. DIN, VDE); equally, you must ensure that all other relevant national or local regulations are met with regard to cable ratings and protection, grounding, disconnectors, overcurrent protection, etc.

During operation, the equipment is protected from direct contact such that it is suitable for use in enclosed electrical premises (DIN VDE 0558 Part 1/07.87, Section 5.4.3.2, preliminary standard EN 50178/VDE 0160/11.94, Section 5.2.6, 5.2.7).

4.1.2 BKD 6 and BKF12 .../6000, Size II (300 A to 600 A)

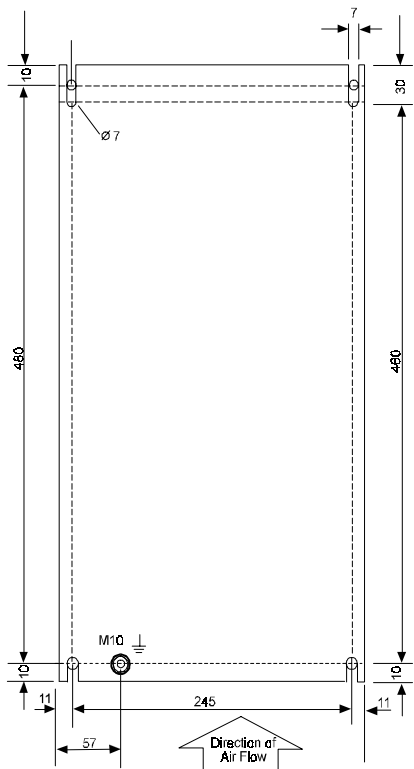
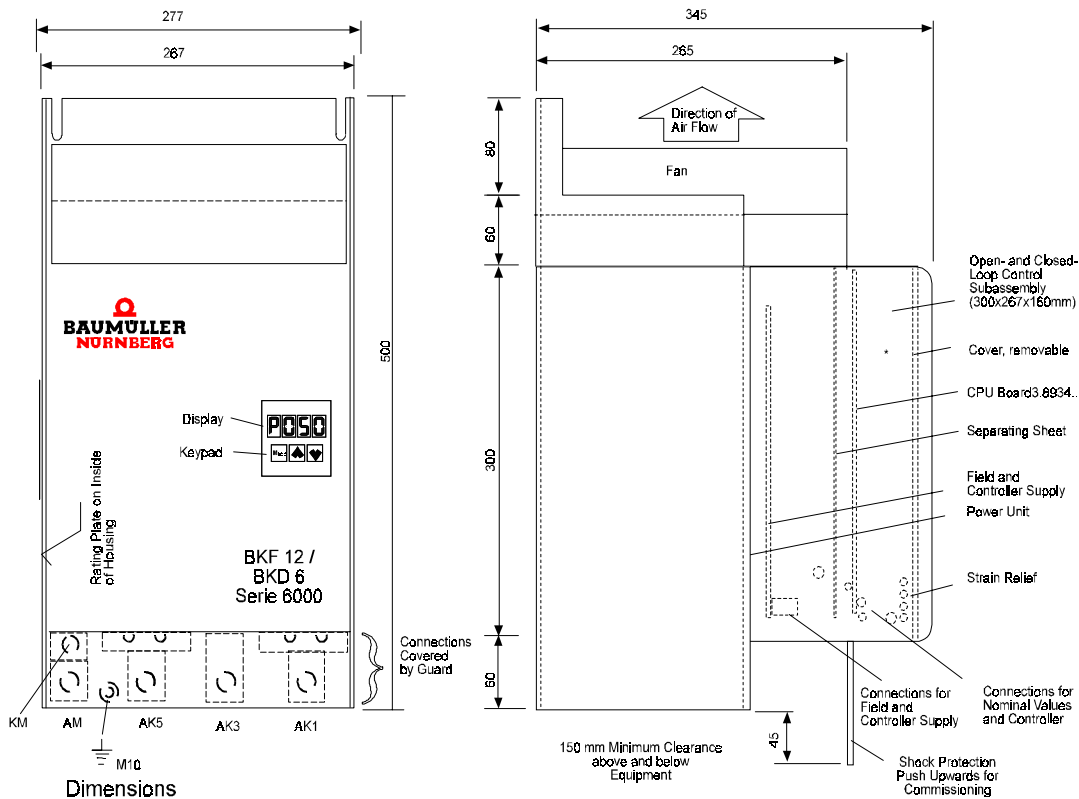

Fastening Holes

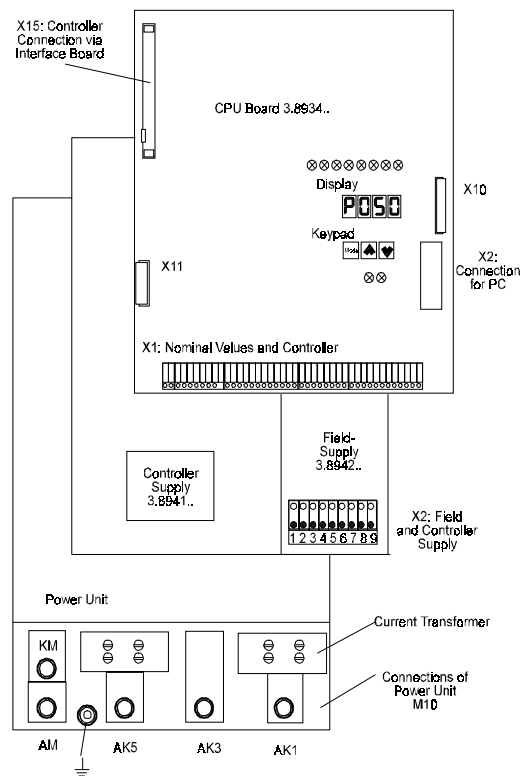

Arrangement of the Modules

⊕ Terminal Stud M10x25,
Power Terminals AK1, AK3, AK5, AM, KM : M10

4.1.3 BKD 6 and BKF 12 .../6000 Sizes III and IV

Size III and IV power converters comprise two modules:

1. Module for closed-loop control (containing amongst other things the controller, the mains unit and the field unit)
2. Power stage module (BKD 6: fully controlled three-phase current bridge circuit B6C; BKF12: two antiparallel switched circular current-free three-phase current bridge circuits (B6C)2I).

The two modules are mounted next to one another; by preference, you should set-up the controller on the left. The modules are electrically connected by an X11 bus cable that is approximately one metre long.

Apart from the depth of the housing, this controller module is electrically and mechanically identical with size I and II controller modules.

• Controller and Field Supply for Sizes III and IV (750 A ... 2050A)

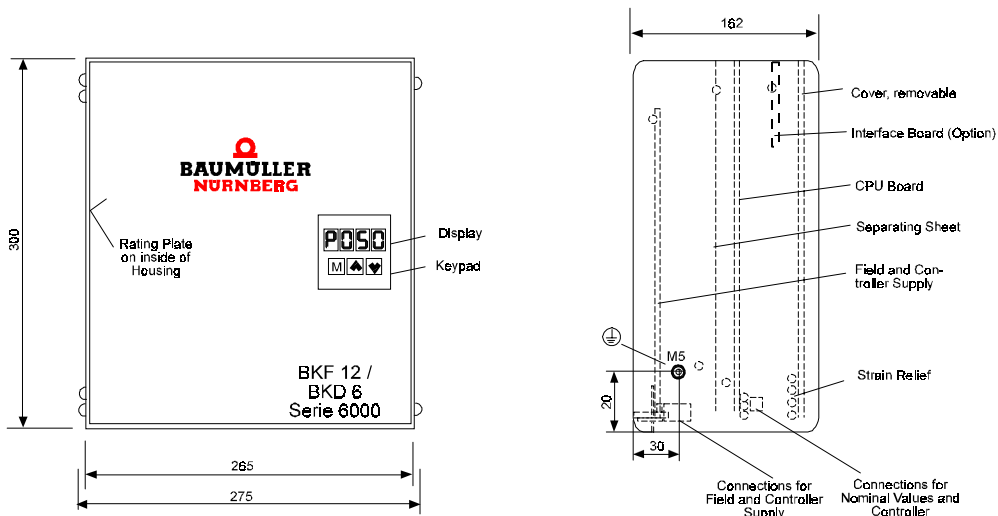

Dimensions

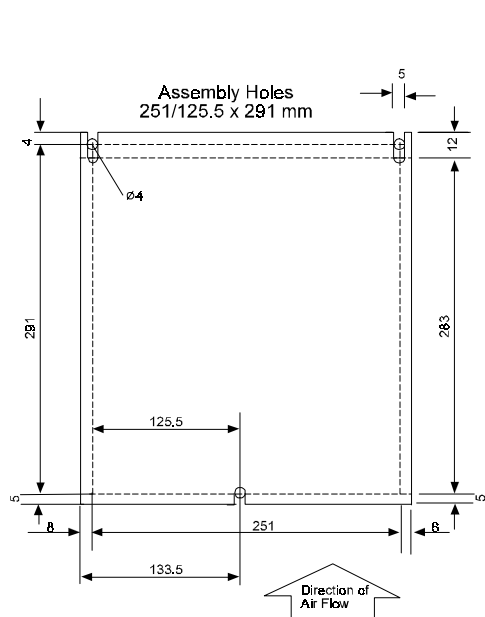

Fastening

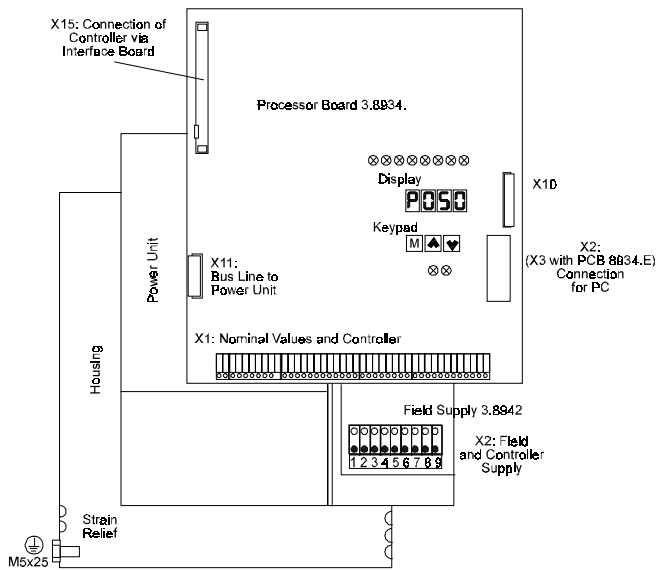

Arrangement of the Modules

 Terminal Stud M5x25

• Power stages for Unit Sizes III and IV

Power stage BKD 6../6000 Size III (750A, 920A)

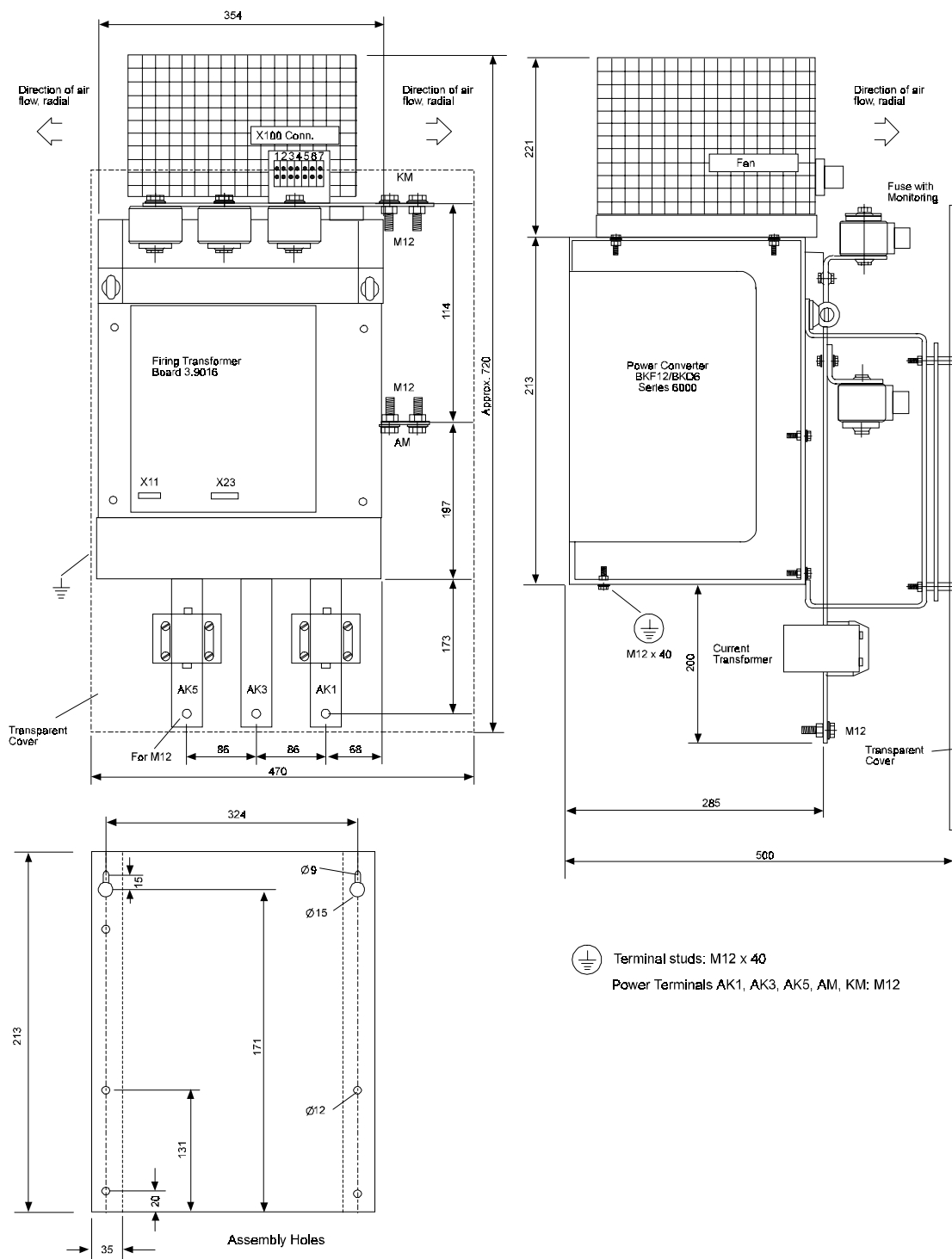

Power stage BKD 6../6000 Size III (1100 A)

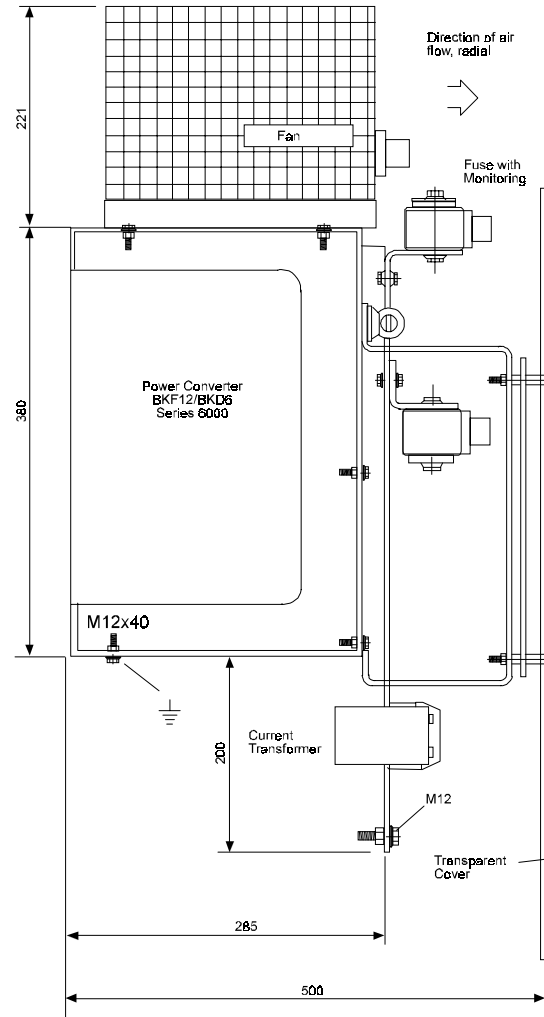
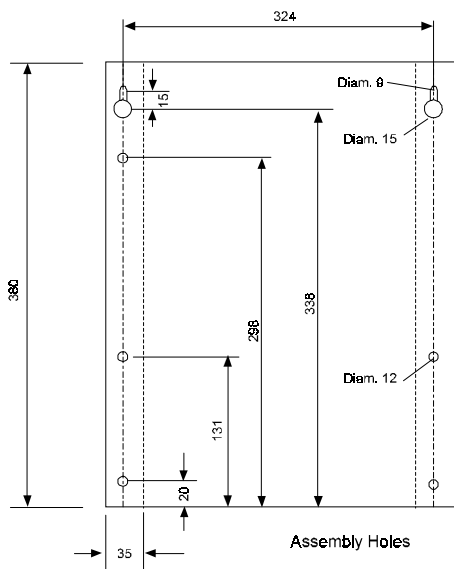
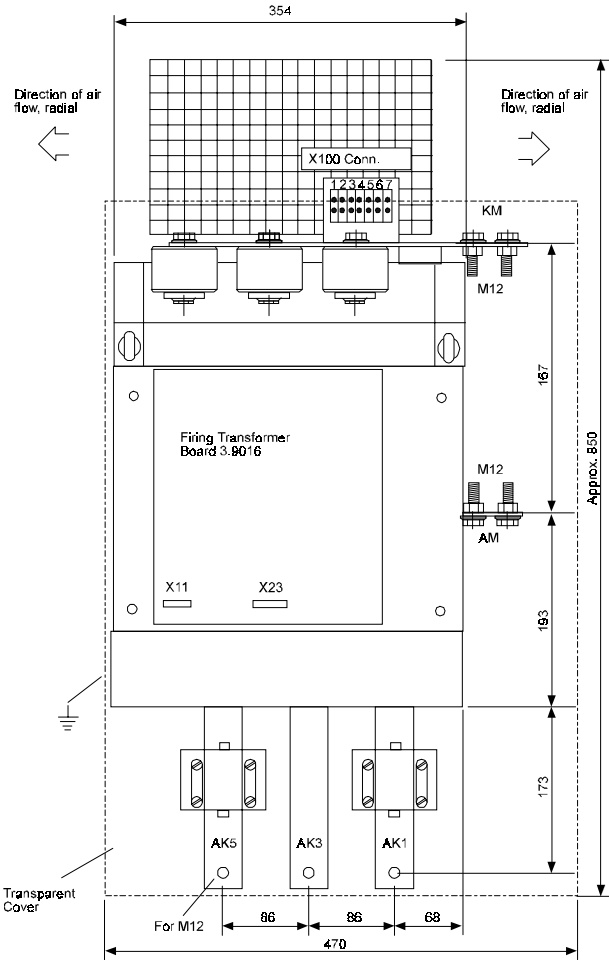

Terminal Stud: M12 x 40
 Power Terminals AK1, AK3, AK5, AM, KM: M12

Power stage BKF 12../6000 Size III (850A)

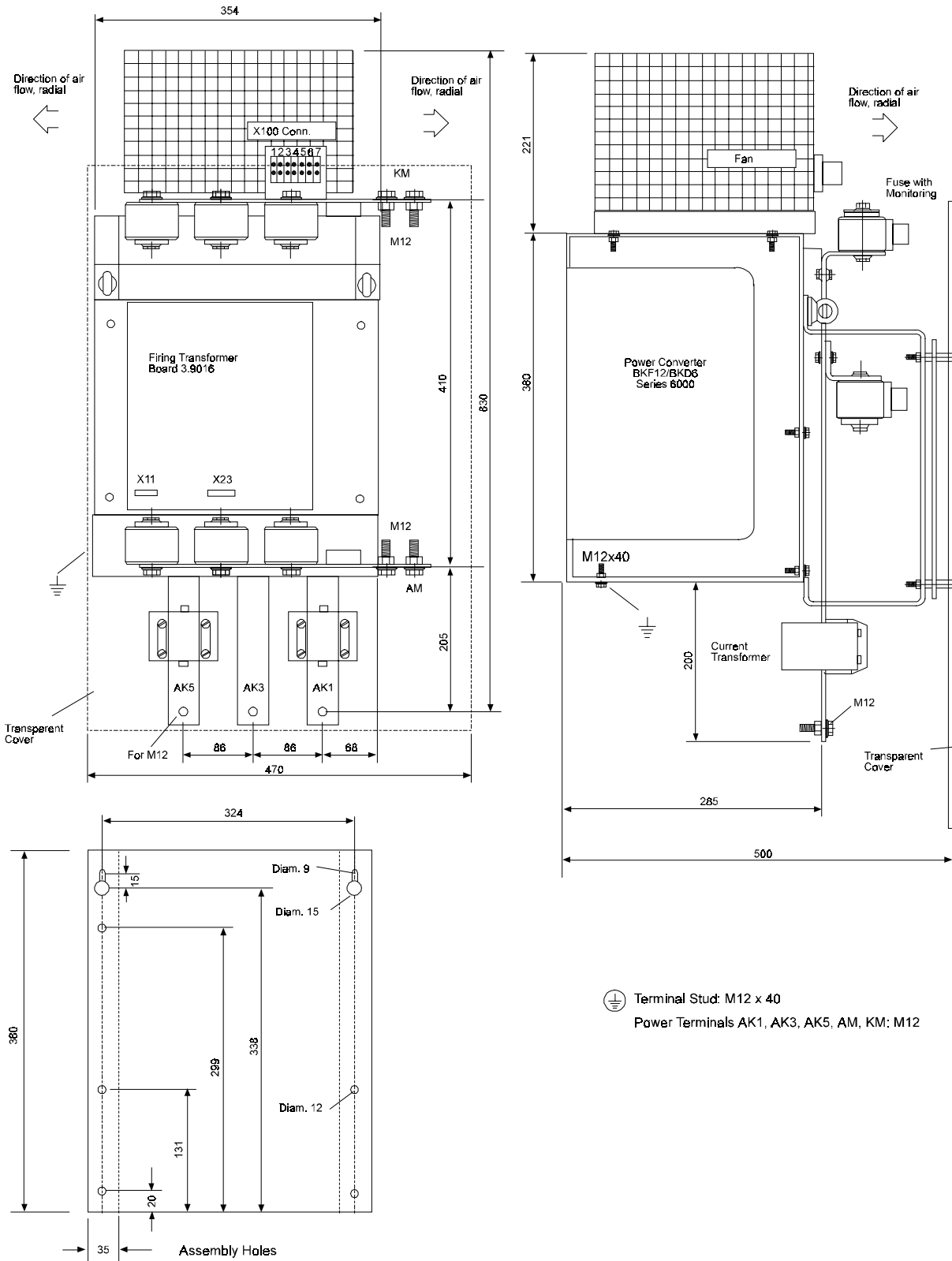

Power stage to Size IV

BKD 6 .../6000: 1550 A, 1750 A, 2050 A
 BKF 12 .../6000: 1250 A, 1400 A, 1650 A

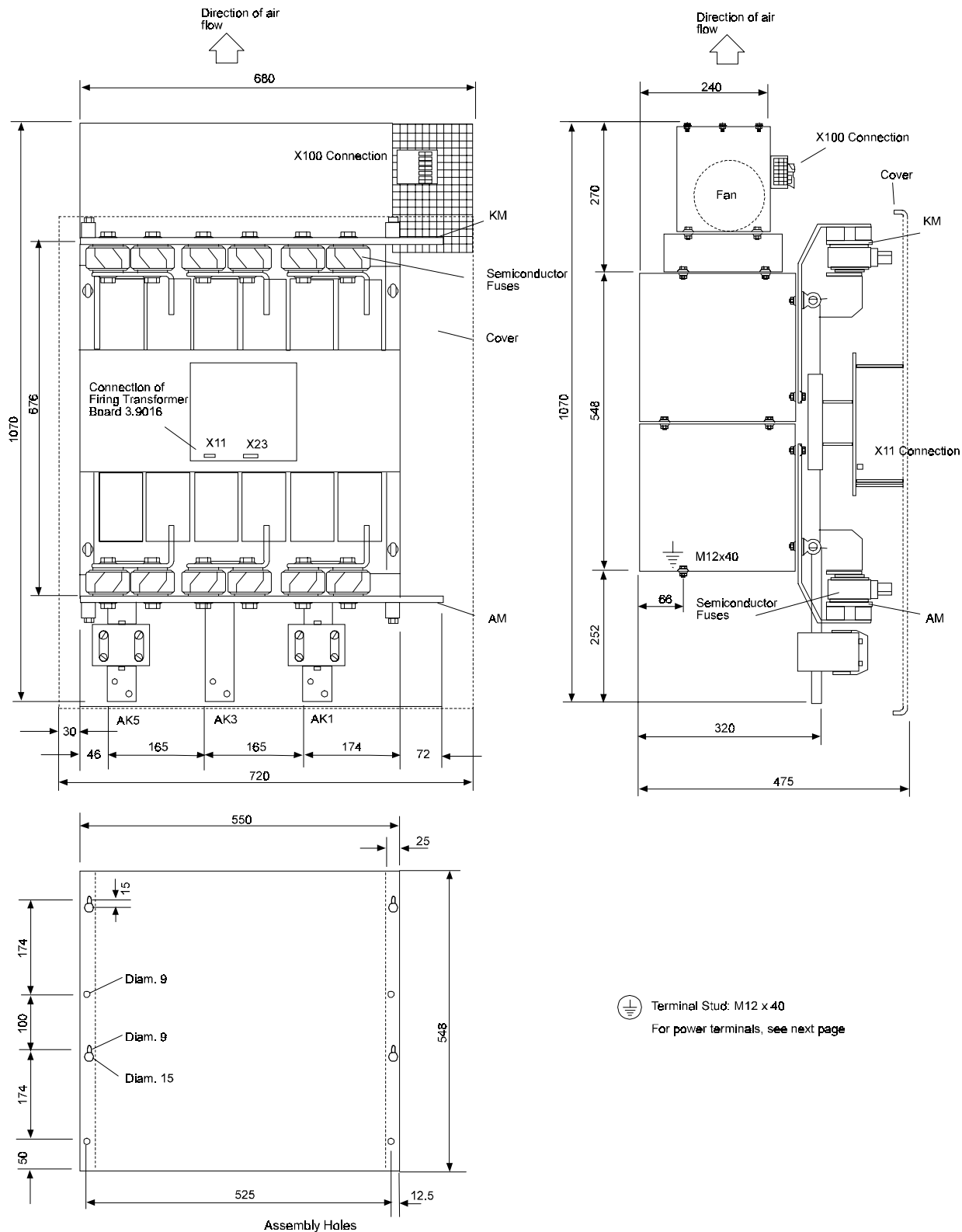

Power connections:

Busbars AK1, AK3 and AK5

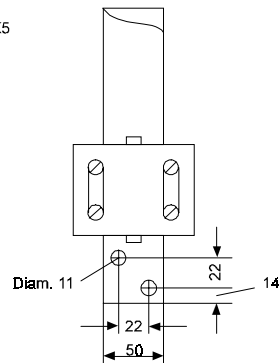

Busbars KM and AM

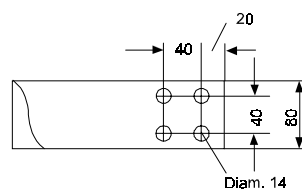

The brackets below are available as an option for connection to DC bars KM and AM:

Order No. 1231965

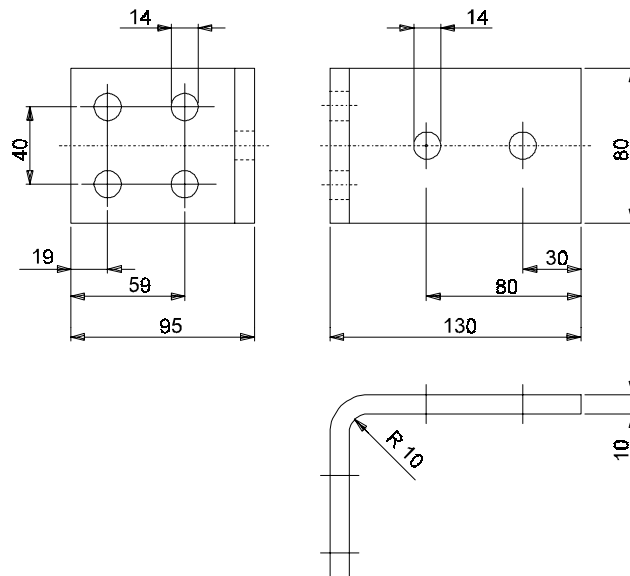

The use of these brackets depends on the type of electrical connection to the DC bars:

If you use crimping cable lugs, the distance between the mounting holes on bars AM and KM may in some circumstances be too small for you to carry out assembly correctly.

4.2 Weights

- Compact units of sizes I and II:

Size I:	30 A nominal current:	15 kg
	50 A ... 200 A nominal current	16 kg
Size II:		30 kg

- Power stages of sizes III and IV:

Size III:	BKD	43 kg ... 54 kg
	BKF	55 kg
Size IV:	BKD	124 kg ... 128 kg
	BKF	124 kg ... 130 kg

- Open-loop control sections of sizes III and IV: 8 kg

4.3 Assembly Information



WARNING

Personal injury or damage to property can be caused by lifting the equipment incorrectly. The unit may only be lifted by qualified personnel using appropriate equipment.

- You must install the units in a closed control cabinet.



WARNING

It is vital to carry out the ventilation measures listed below. Ignoring these measures may lead to the equipment overheating.

- Power converters are designed to be mounted vertically. If you want to mount the unit in another position ask for more information at the factory
- The equipment must be ventilated from the bottom to the top.
- Ensure that the flow of air is not obstructed.
- The clearance above and below the equipment must be at least
 - 150 mm with size I units
 - 200 mm with size II units
 - 250 mm (beside the fan too) with size III units
 - 300 mm with size IV units

Ignoring these measures may lead to the equipment overheating.

- Temperature of coolant 50 mm below the equipment:
 - Power stage

30-A power converter (self-ventilated):	up to 45°C
All other units (force-ventilated):	up to 35°C

At relatively high temperatures (up to a maximum of 55°C) the unit's nominal current must be reduced by 1% per degree Centigrade.

- Field current converter
 - referred to the rated-load field currents
 - 10 A, 15 A and 25 A up to 45°C

At relatively high temperatures (up to a maximum of 55°C), the unit's nominal current must be reduced by 1% per degree Centigrade.

- Do not mount any additional sources of heat above or below the equipment.
- Avoid soiling grades 3 and 4 according to provisional standard EN 50178/VDE 0160/11.94, Section 5.2.15.2.
- Make the PE connection to the central grounding point as short as possible.
- Size III and IV power converters comprise two modules. By preference, you should place the smaller module – the controller with the mains unit and field supply – on the left hand side at a distance of about 100 mm from the power stage.

5 INSTALLATION

5.1 Danger and Warning Information



WARNING

This equipment carries a dangerously high voltage and has dangerous rotating parts (fans). Ignoring the safety and warning information may result in death, severe personal injury or damage to property.

The machine operator is responsible for mounting the power converter, the motor, the commutating reactor and any other equipment in accordance with appropriate safety regulations (e.g. DIN, VDE); equally, you must ensure that all other relevant national and local regulations are met with regard to cable ratings and protection, grounding, disconnectors, overcurrent protection, etc.

The most important factors for protecting people are the DIN/VDE protective measures and safety regulations. If there are no protective earth connections on the equipment, the commutating reactor or the motor, personal injuries are inevitable, since the surfaces can carry dangerously high voltages.

The power converter's terminal connections are energized!

Even when the main contactor has tripped, parts of the power converter (the mains unit, the field power converter) still carry a dangerous voltage.

During operation, the principles on which the power converter and the motor work lead to leakage currents to earth that are dissipated via the specified protective earths and may result in a current-operated e.l.c.b. on the input side blowing prematurely.

In the case of a short-circuit to frame or to ground, a direct proportion may arise in the leakage current that makes triggering of a higher-level current-operated e.l.c.b. either more difficult or totally impossible.

You must make the protective earth connection in accordance with DIN EN 60204 Part 1/VDE 0113 Part 1/06.93/Section 8.2.2 taking into account provisional standard EN 50178/VDE 0160/11.94, Sections 5.3.2.1 and 8.3.4.4.

You may only use variable speed drives in applications corresponding to applicable VDE regulations.

Speed monitoring systems in the equipment must not just be complemented by a stand-alone monitoring system on the motor. You can implement this control of the RPM speed, which is independent of the controller, by means of inductive, optical or torque-dependent encoders. Refer to the appropriate motor's operating and maintenance instructions.

Be particularly careful before touching the drive shaft directly or indirectly with your hands. This is only allowed when the system is deenergized and the drive is stationary.

Safety devices must never be deactivated.

According to applicable regulations (DIN EN 60204 Part 1/VDE 0113 Part 1/06.93/Section 8.2.2), stopping the drive by means of the four enabling inputs at terminals X1:22 ... 25, does not, on its own, represent a safe stop condition. A disturbance in the control electronics can lead to accidental starting of the motor.

5.2 Standardization Information

Series BKD 6/...- and BKF 12/...6000 are built-in units in the sense of provisional standard EN 50178/VDE 0160/11.94, Section 5.2.6 and DIN VDE 0558 Part 1/07.87, Section 5.4.3.2.1. They are intended for installation in commercially available control cabinets whose degrees of protection meet the minimum requirements of provisional standard EN 50178/VDE 0160/11.94, Section 5.2.4 (IP 2x, possibly IP4x according to EN 60529/5.1).

Plastic covers on the equipment provide additional protection against accidental contact in the case of casual use of control elements located close to the equipment (DIN VDE 0106 Part 100, Accident Prevention Regulation VBG4 "Electrical Systems and Equipment").

If you intend to set up the equipment in closed electrical workshops according to provisional standard EN 50178/VDE 0160/11.94, Section 5.2.7 and DIN VDE 0558 Part 1/07.87, Section 5.4.3.2.2, you must implement additional measures to ensure compliance with the requirements of provisional standard EN 50178/VDE 0160/11.94, Section 5.2.4.

Power converters are intended for permanent mains connection to conventional TN and TT systems according to DIN VDE 0100 Part 410/11.83 with a diametric voltage of up to $3 \times 500 V_{\text{eff}}$.

Connecting to a system with an insulated neutral point (IT system) is only possible under special circumstances. If necessary, enquire at the factory.

With regard to climatic conditions, the equipment conforms to category 3K3 for sheltered locations according to provisional standard EN 50178/VDE 0160/11.94, Section 6.1, Table 7, Line 3 or Table 1 of EN 60721-3-1,2,3,4 respectively, taking into account Remarks 1 and 3 of provisional standard EN 50178/VDE 0160/11.94, Section 6.1. The actual operating temperature range is higher and is in the range $0 \dots +55^{\circ}\text{C}$. The information in Table 7 (lines 5 and 6) of provisional standard EN 50178/VDE 0160/11.94, Section 6.1 also applies to storage and transportation.

The storage and transportation temperature of the equipment varies from this information in as much as it may be between $-30 \dots +70^{\circ}\text{C}$ (refer to Chapter 2.3 of the Power Converter's Technical Data).

The units are in protection class IP 00 according to EN 60529 (DIN VDE 0470-1)

The units are equipment in protection class I corresponding to IEC 536/3 and DIN VDE 0106 Part 1 (provisional standard EN 50178/VDE 0160/11.94, Section 5.2.9).

Equipment of protection class I is equipment whose protection against dangerous shock currents is not limited to basic insulation but which also has additional safety devices. This additional protection is provided by connecting the housing and other parts to the protective earth such that if the basic insulation fails no voltage can remain. With these power converters, the entire insulation is carried out according to provisional standard EN 50178/VDE 0160/11.94, Section 5.2.9.1, at least to basic insulation standard. This also applies to the insulation between the individual circuits.

The power converters' control terminals are designed for connection of FELV circuits that must be protected from direct and indirect contact. The rated insulation voltage is $300 V_{\text{eff}}$, i.e. you can use normal plastic-insulated control lines.

You may not connect SELV and PELV circuits without taking special measures.

At measurement of the creepage distances and clearances, the following criteria were taken into account:

- Soiling grade 2 according to provisional standard EN 50178/VDE 0160/11.94, Section 5.2.15.2, Table 2, Line 3:
Normally, only non-conducting pollutants are produced. When the equipment is out of service, brief conductivity can occur due to condensation.
- Overvoltage category III according to IEC 664-1, Table 1 for the air clearances of mains circuits to their environment according to provisional standard EN 50178/VDE 0160/11.94, Section 5.2.16.1.
- The rated insulation voltage of the mains circuits for TN and TT systems according to DIN VDE 0100 Part 410/11.83 with a diametric voltage of $3 \times 500 \text{ V}$.
- Insulation material IIIa for creepage distances according to provisional standard EN 50178/VDE 0160/11.94, Section 5.2.17.

Series 6000 line-commutated power converters are short-circuit-proof in the sense of provisional standard EN 50178/VDE 0160/11.94, Section 6.3.4, assuming that you use the protective semiconductor fuses specified in Section 5.4 of this technical description to protect the thyristors.

5.3 Connection Plans

The open- and closed-loop control module is the same with all the power converters, regardless of the size of the unit, or whether it is used as a single-quadrant power converter or as a four-quadrant one.

The only differences are in the type and version of the power stage fitted.

For this reason, the terminal diagrams shown below are subdivided as follows

- terminal diagram for the controller module
- terminal diagrams for the individual power stages
- terminal diagrams for various daughterboards

NOTE

You must wire the equipment according to the connection suggestion or the terminal connection diagram.

The nominal value and actual value cables must be screened and run separate from the power lines (the motor armature, the field and the mains connection). You must also run the control lines separate from the power lines in their own cable ducts.

Ensure that the contactors in the vicinity of the unit are protected by appropriate fuses. A faulty equipment connection can result in the power converter being damaged or completely destroyed.

5.3.1 Connecting Controller Module Sizes I ... IV

Screening of the electrical signal lines:

You must screen the signal lines on the cable clamps mounted on the side of the power converter (next to terminal strip X1).

- Standard Unit (Type Code BKF 12/.../... -60400... and BKD 6/.../... -60400...)

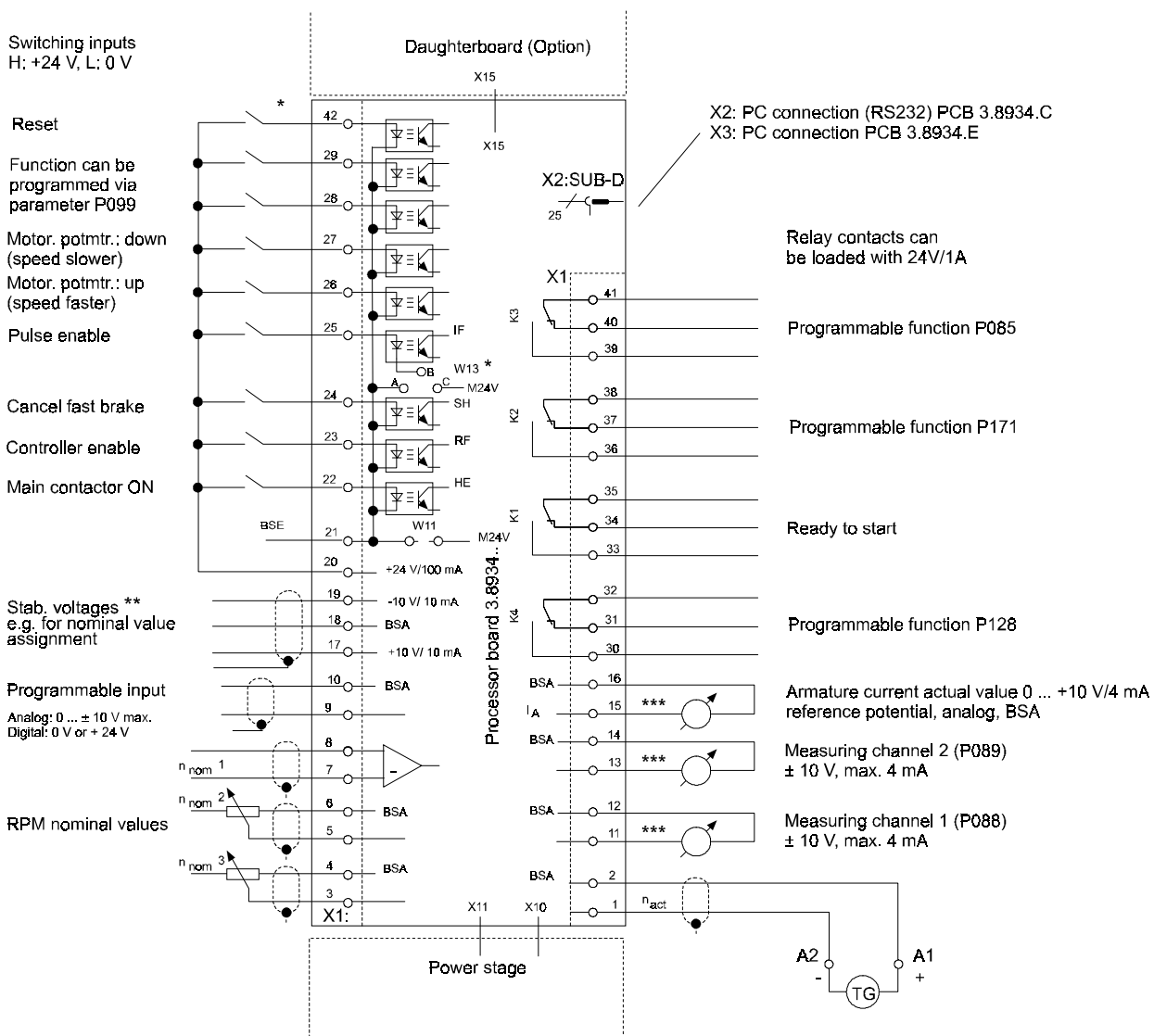

* PCB version 3.8934.E and above

** R_i = 100 Ω

*** R_i = 100 Ω

- Special Design with Switching Mains Unit
(Type Code BKF 12/.../... -60401... and BKD 6/.../... -60401...)

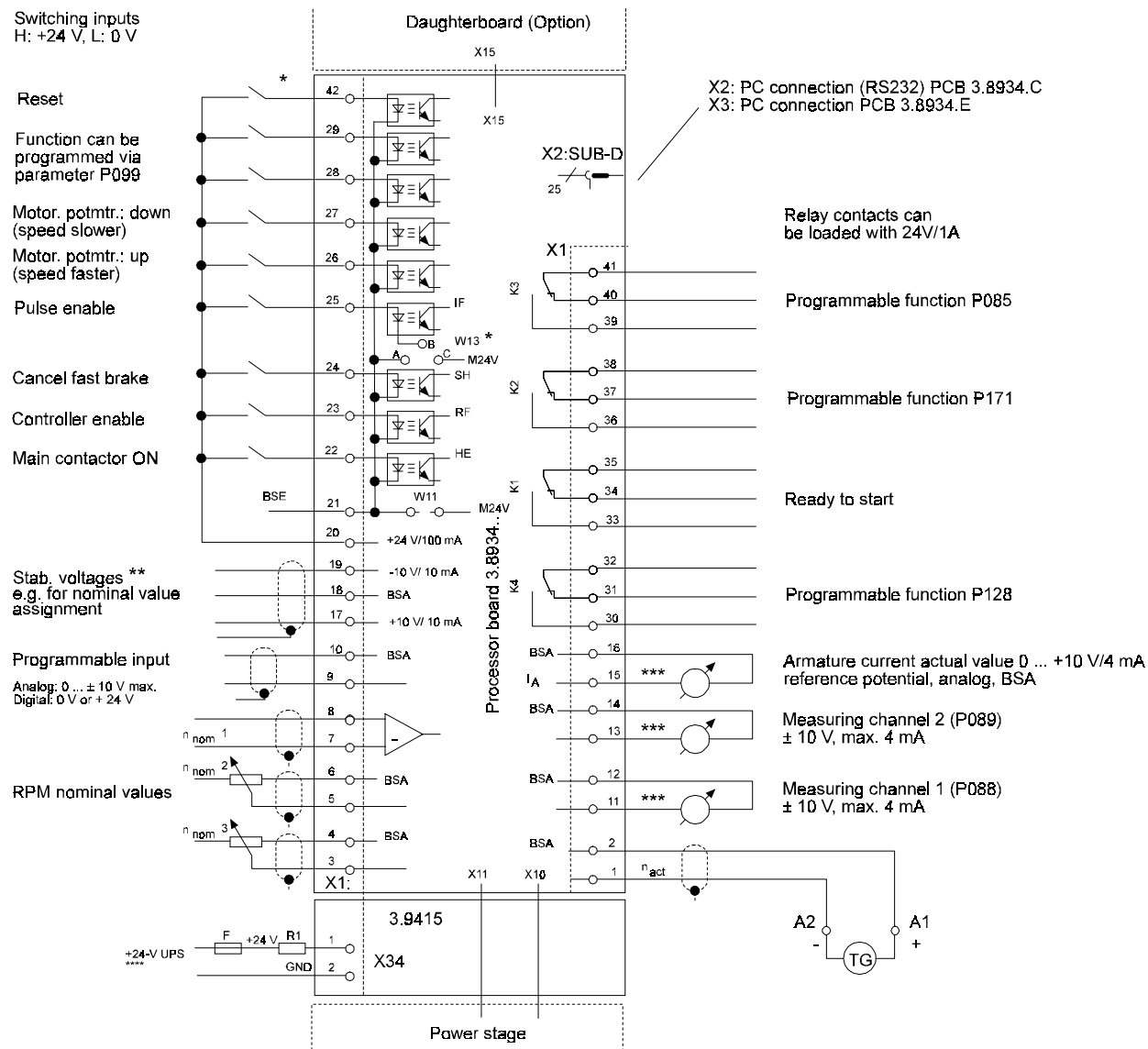

* PCB version 3.8934.E and above

** $R_i = 100 \Omega$

*** $R_i = 100 \Omega$

**** Automatic restart with the special version with a switching power supply and a stored energy time of up to six seconds (see 6.8.2). See also chapter 2.11, Adapting Power Converters to Different Connection Voltages.

Connection for the uninterruptible power supply (UPS) X34:1/2

Range: 21 V. ... 30 V., Nom. current: 1.7 A with unit completely fitted

Perm. starting current inrush: max. of 50 A, limiting by external measures (e.g. R1)

Connection Information

Soldering jumpers:

W11: Reference point for control inputs X1:22 ... 29
 is fitted if the +24 V is to be taken at the unit for power converter enables; do not fit it if the enables come directly from the PLC or the controller!
 In this case, the reference potential is terminal X1:21 (BSE); the jumper is fitted at the factory.

W13: Specifying the reference point for control input X1:25 (pulse enable).
 Jumper A-B selects the reference point that was specified with W11 for the other control inputs.

You use jumper B-C to permanently connect the reference point to the device-internal ground reference (M24V). This makes possible connection of pulse enable to the power converter's 24V even when the higher-level controller supplies the other enables.
 With this control variant, voltage failures in the external controller, which would otherwise result in pulse inhibit do not negatively affect the power converter:
 Uncontrolled removal of pulse enable at the power converter can damage the unit:
 Pulse enable is a completely hardware function that intervenes directly in the output stage (pulse generation). If the firing pulses are suppressed during braking, this can lead to the fuse in the mains line dropping. In a worst case situation, the thyristors can be damaged (inverter tilting)!

Terminal strip X1:	Terminal blocks
	Terminal cross-section 0.2 ... 2.5 mm ²
X1: 1	RPM actual value Polarity negative with clockwise rotation of motor (A-side)
X1: 2	Reference potential For RPM actual value BSA
X1: 3	RPM spec. value 3 0 ... ±10 V, summing amplifier input. The sum of RPM nominal values 2 and 3 together should not exceed 10 V. Values above 10 V are limited. Input resistance R _E = 55 kΩ.
X1: 4	Reference potential For RPM actual value 3 BSA
X1: 5	RPM nom. value 2 0 ... ±10 V, summing amplifier input. The sum of RPM nominal values 2 and 3 together should not exceed 10 V. Values above 10 V are limited. Input resistance R _E = 55 kΩ.

X1: 6	Reference potential BSA	For RPM nominal value 2
X1: 7,8	RPM spec. value 1	0 ... ± 10 V, differential amplifier input. Nominal value adaptation to 10 V by means of potentiometer R 100. Input resistance $R_E = 55$ k Ω .
X1: 9,10	Programmable input	Can be programmed via P084 Analog input: 0 ... ± 10 V Switching input: 0 V or +24 V
X1: 11,12	Meas. channel 1	0 ... ± 10 V, maximum of 4 mA, selection of test point using P088; Resolution 150 mV; highest resolution with daughterboard 3.9201: Dual DAC 12, for example. For interference immunity, use screened cables.
X1: 13,14	Meas. channel 2	0 ... ± 10 V, maximum of 4 mA, selection of test point using P089; Resolution 150 mV; highest resolution with daughterboard 3.9201: Dual DAC 12, for example. For interference immunity, use screened cables.
X1: 15	Armature current actual value	0 ... ± 10 V, 4 mA, corresponds to nominal current with P025=1; with P025 < 1, the value reduces proportionally. The system takes the value directly from the load resistor so that it is not digitized; the signal is not decoupled. For interference immunity, use screened cables.
X1: 16	Reference potential BSA	BSA for armature current actual value
X1: 17	Nom. value supply	RPM specified voltage value stabilized, +10 V/10 mA, $R_i = 100$ Ω
X1: 18	BSA	Reference potential for RPM nominal values ± 10 V
X1: 19	Nom. value supply	RPM specified voltage value stabilized, -10 V/10 mA, $R_i = 100$ Ω
X1: 20	+ 24 V/100 mA	For enables only, voltage not stabilized, short-circuit-protected (PTC)
X1: 21	Reference potential BSE	For enables; when using the device-internal 24 V from X1 :20, jumper W11 must be fitted. When using the 24 V from the controller, W11 must not be fitted. This electrically isolates the controller from the electronic ground (optocoupler inputs). In the case of electrical isolation, a difference in potential to the electronic ground of 50 V is permissible.
X1: 22	Main contactor ON	
X1: 23	Controller enable	
X1: 24	Cancel fast brake	
X1: 25	Pulse enable	

X1: 26	Motor pot. function	Increase speed; on applying +24 V, the motor accelerates, you can set the ramp and the maximum nominal value. The switching input is decoupled via an optocoupler, input resistance $R_E = 3 \text{ k}\Omega$.
X1: 27	Motor pot. function	Decrease speed; on applying +24 V, the motor decelerates, you can set the ramp and the maximum nominal value. The switching input is decoupled via an optocoupler, input resistance $R_E = 3 \text{ k}\Omega$.
X1: 28,29	Switching inputs	Function can be programmed by means of parameter P099, switching inputs via optocoupler, input resistance $R_E = 3 \text{ k}\Omega$.
X1: 30	Temperature	Option of:
31	monitoring,	Relay K4 picks up at P128=0 if the temperature of the power stage or the motor (I^2t) is too high,
32	Drive ON	Relay K4 picks up at P128=1 if the temperature of the power stage and the motor (I^2t) are OK and the controller is enabled. Relay contacts can be loaded with 24 V/1 A.
X1: 33		Ready relay K1 picks up if the equipment is ready for operation.
34		In the case of an error, the relay releases for at least one second.
35		Relay contacts can be loaded with 24 V/1 A.
X1: 36	Programmable	Option of:
37	monitoring	Relay K2 picks up if RPM speed n_x is exceeded (P171=0).
38		Relay K2 picks up if armature current I_x is exceeded (P171=1). Relay contacts can be loaded with 24 V/1 A.
X1: 39	Programmable	Option of:
40	monitoring	Relay K3 picks up when the operating speed is reached (P085=0) Speed nominal value at ramp function generator input;
41		Relay K3 picks up if armature current I_x is exceeded; (P085=1) Relay K3 picks up if RPM speed n_x is exceeded; (P085=2) Relay K3 picks up if the drive is ready-to-start; (P085=3) Relay K3 picks up if the field current is OK; (P085=4) Relay K3 picks up on reaching operating RPM speed; (P085=5) RPM nominal value at speed controller input; Relay contacts can be loaded with 24 V/1 A
X1: 42	Reset	Processor board 3.8934.E and above (+24 V: Reset active)

NOTE

You must only specify a reset for the power converter when the controller is disabled **and** the motor is idle.

X2: RS232 25-pin SUB-D socket for PC connection (terminal strip)

NOTE

Do not confuse with terminal X2 on field controller 3.8942 (power terminals).

Pin No.	Assignment
1	5-V ground
2	RxD RS232
3	TxD RS232
4	Not assigned
5	+15 V
6	+15 V
7	5-V ground
8	+15 V
9 ... 25	Not assigned

X10: 34-pin ribbon cable to mains unit 3.8941 and to field controller 3.8942; only disconnect internally when the unit is deenergized!

X11: 26-pin ribbon cable to power stage 3.8938, 3.8939 or 3.9016; only disconnect internally when the unit is deenergized!

X15: 64-pin ribbon cable to interface card; only disconnect internally when the unit is deenergized!

Terminal strip X34: Terminal block terminal cross-section 0.2 ... 2.5 mm²

X34:1,2 Connection for uninterruptible power supply (UPS) 24 V (21 V ... 30 V), 50 W

X34:1 +24 V connection

X34:2 Reference point is electrically isolated from the electronic ground BSA

F Line protection Observe the starting current inrush!
The rating and characteristic of the fuse depend on the level of the inrush current. AT $\hat{I} = 50$ A: it must be at least 6 A slow-blow according to DIN 41571

R1 Limiting of the starting current inrush to a maximum of 50 A!

The following measures are allowed for current limitation at terminal X34:1:

- Using an external current supply with integrated current limitation
- Current limitation by means of a series resistor ($\geq 0.5 \Omega$, 4 W). The resistor may be permanently switched on if it can be guaranteed that the permissible input voltage range is not fallen below ($U_{\text{inp}} = 21 \text{ V} \dots 30 \text{ V}$, current consumption 1.7 A max.). Otherwise, bridging of the resistor after an ON period of 100 ms at the earliest (this applies to $R = 0.5 \Omega$, higher resistance values need a correspondingly long ON period).
- Switching-in the external 24-V supply is possible even without current limiting if it can be guaranteed that
 - a) the 24 V is applied at least 100 ms after application of the mains voltage (at X2:1,2)
and
 - b) the mains voltage is within the tolerance band of 400 V/460 V/500 V -15 % + 10 %.

With applications in which you intend to connect the switching power supply to mains voltages that differ from the power converter's rated values, switching-in may not be carried out under any circumstances without additional current-limiting measures being taken!

5.3.2 Connecting Power Stage BKF 12/6000 Sizes I ... IV

- Connecting Power Stage BKF 12/6000 Size I

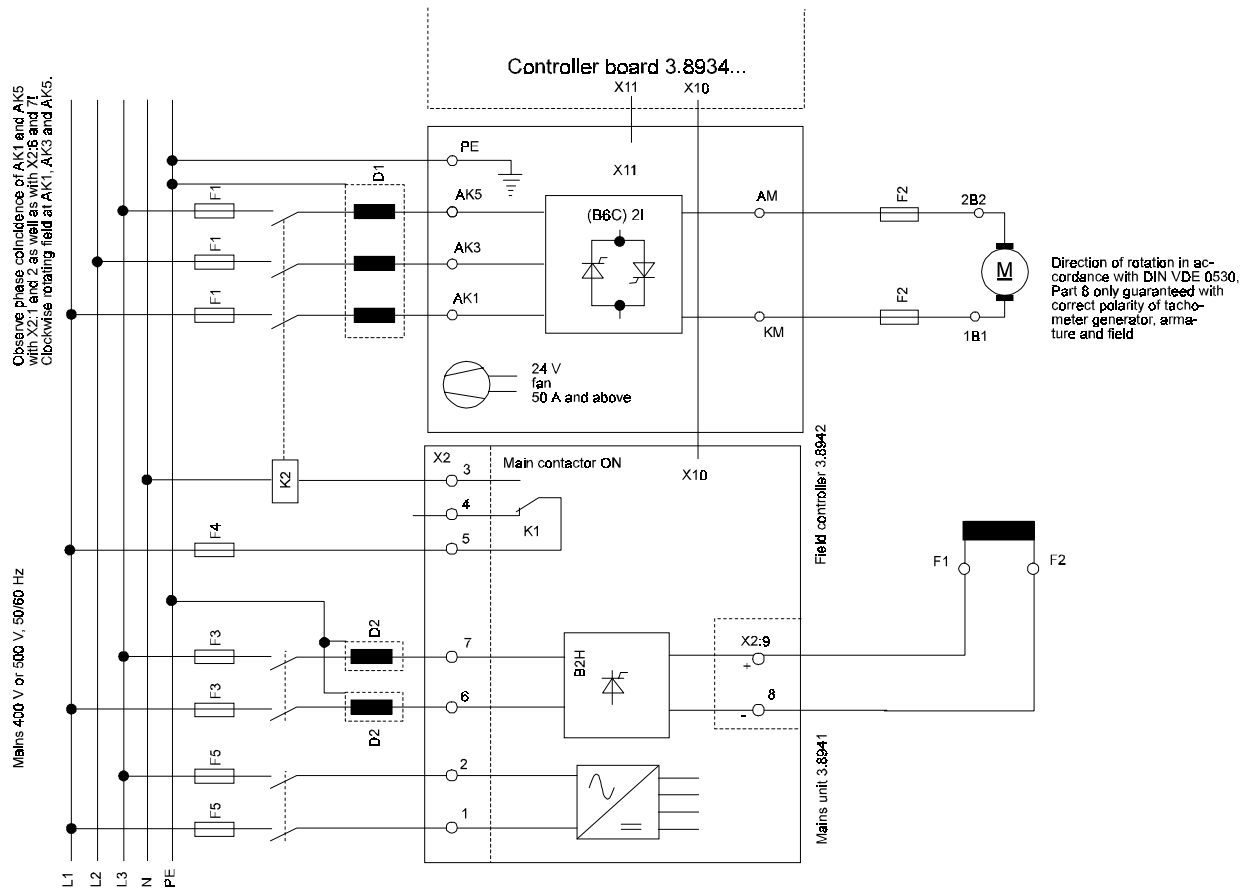

- **Connecting Power Stage BKF 12/6000 Size II with Field Supply for 15 A max.**

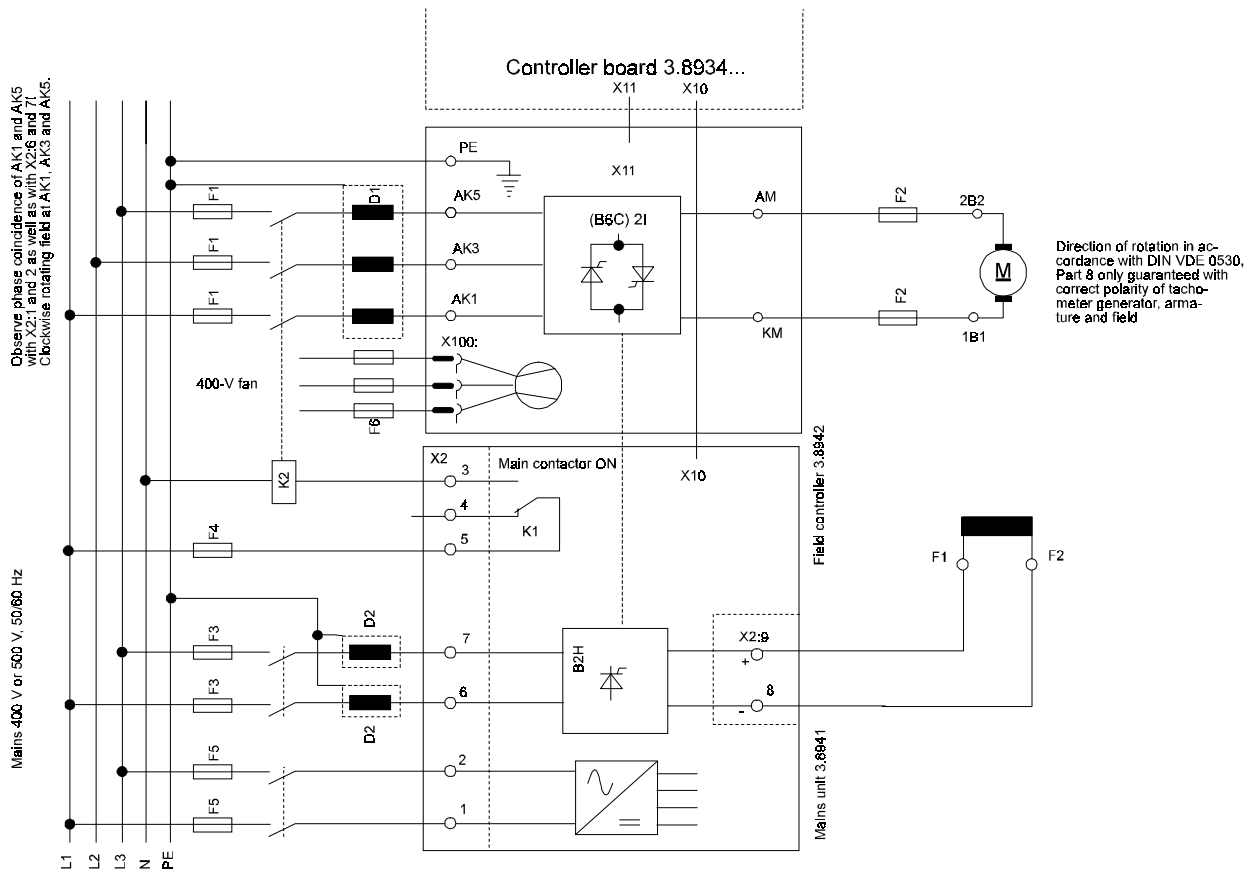

with 25-A Field Supply

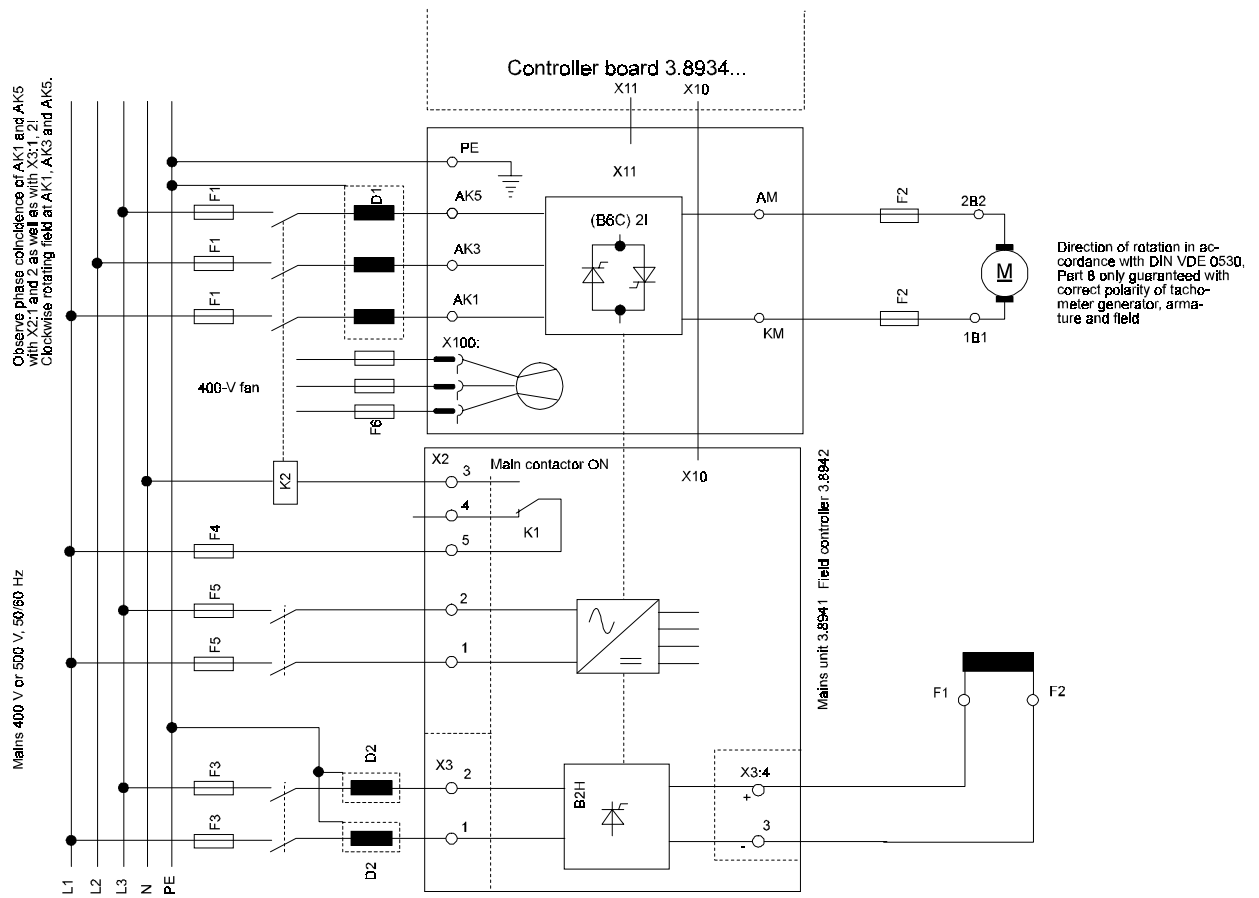

- **Connecting Power Stage BKF 12/6000 Size III with Field Supply for 15 A max.**

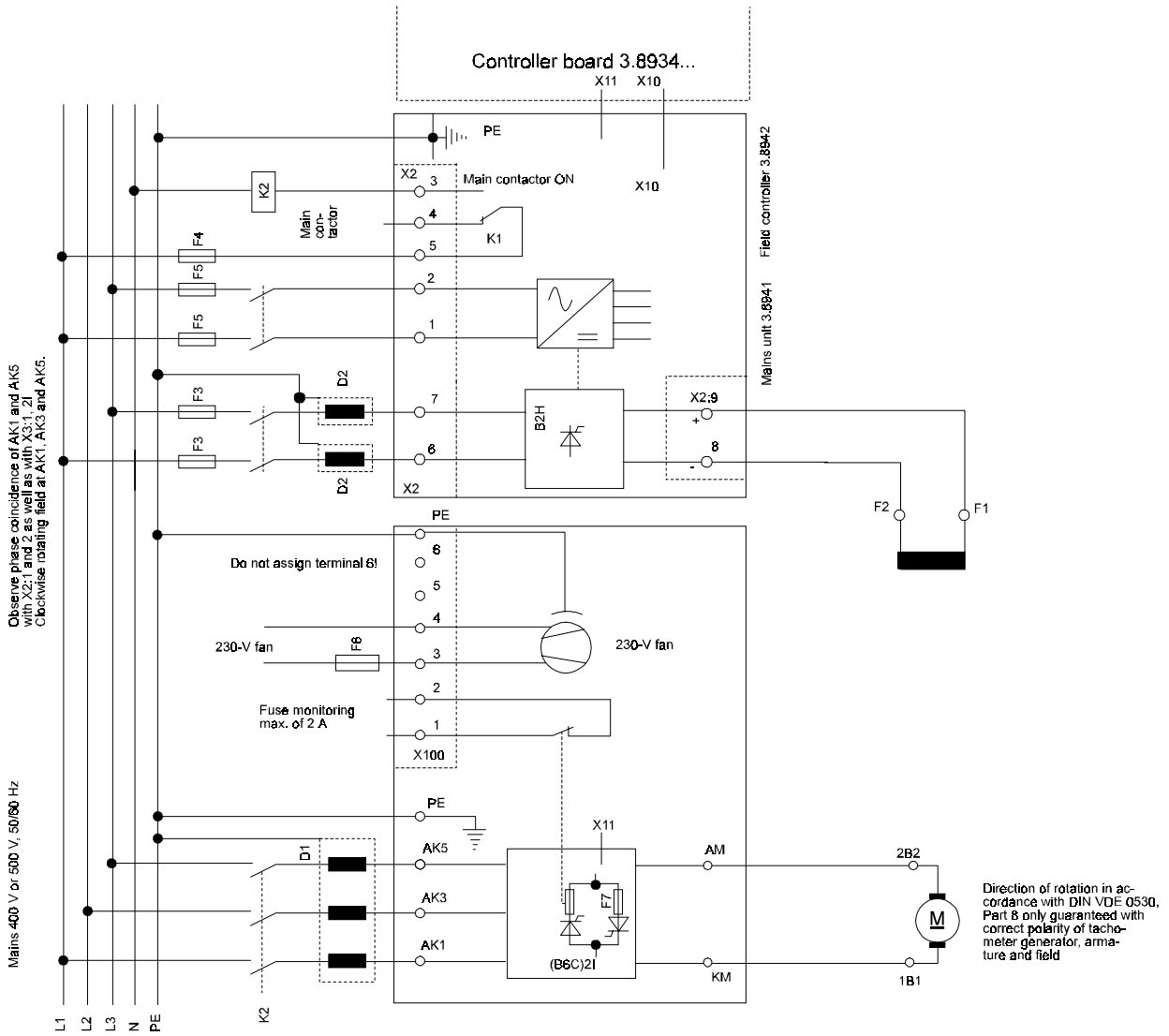

- **Connecting Power Stage BKF 12/6000 Size IV with Field Supply for 15 A max.**

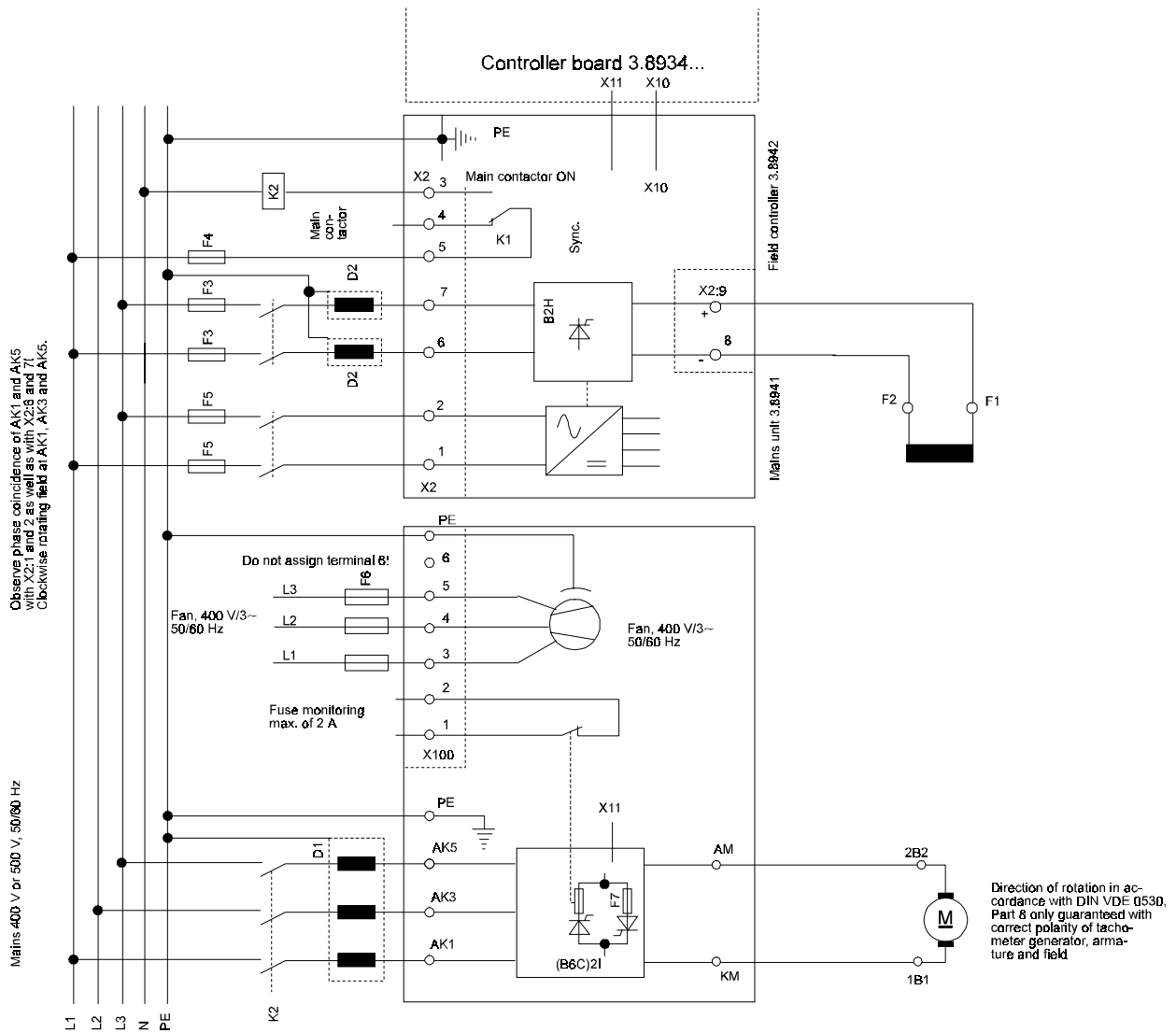

with 25-A Field Supply

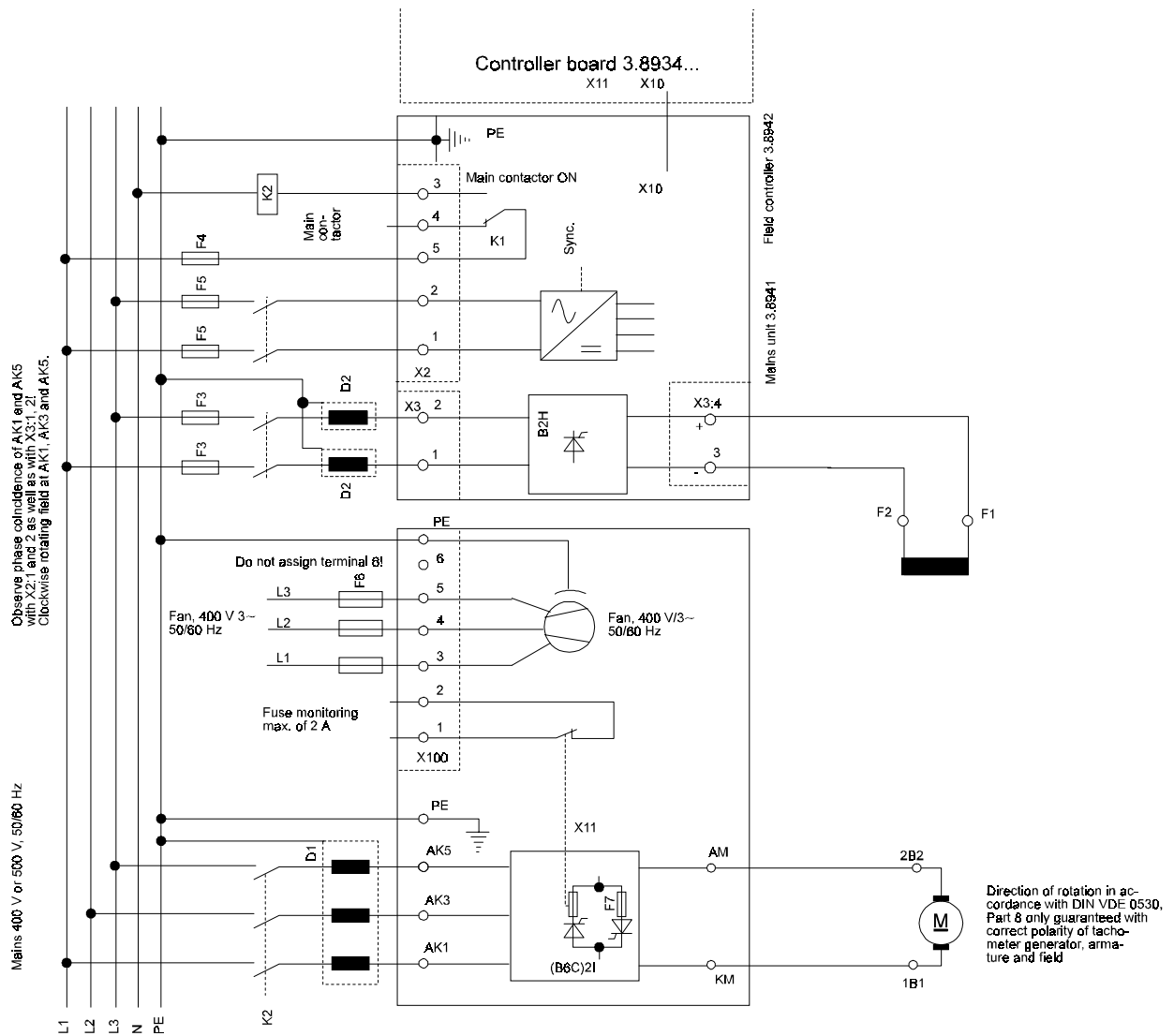

5.3.3 Connecting Power Stage BKD 6/6000 Sizes I ... IV

- Connecting Power Stage BKD 6/6000 Size I

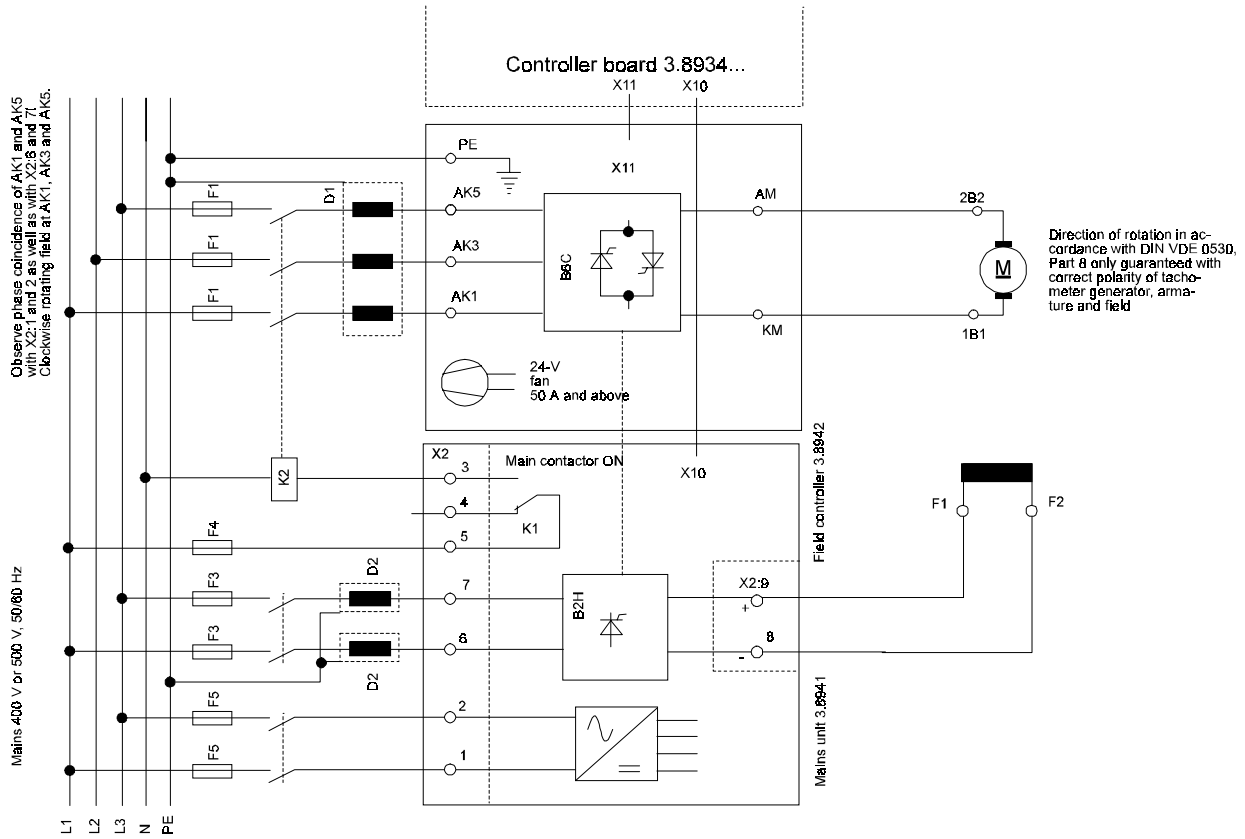

- Connecting Power Stage BKD 6/6000 Size II**
with Field Supply for 15 A max.

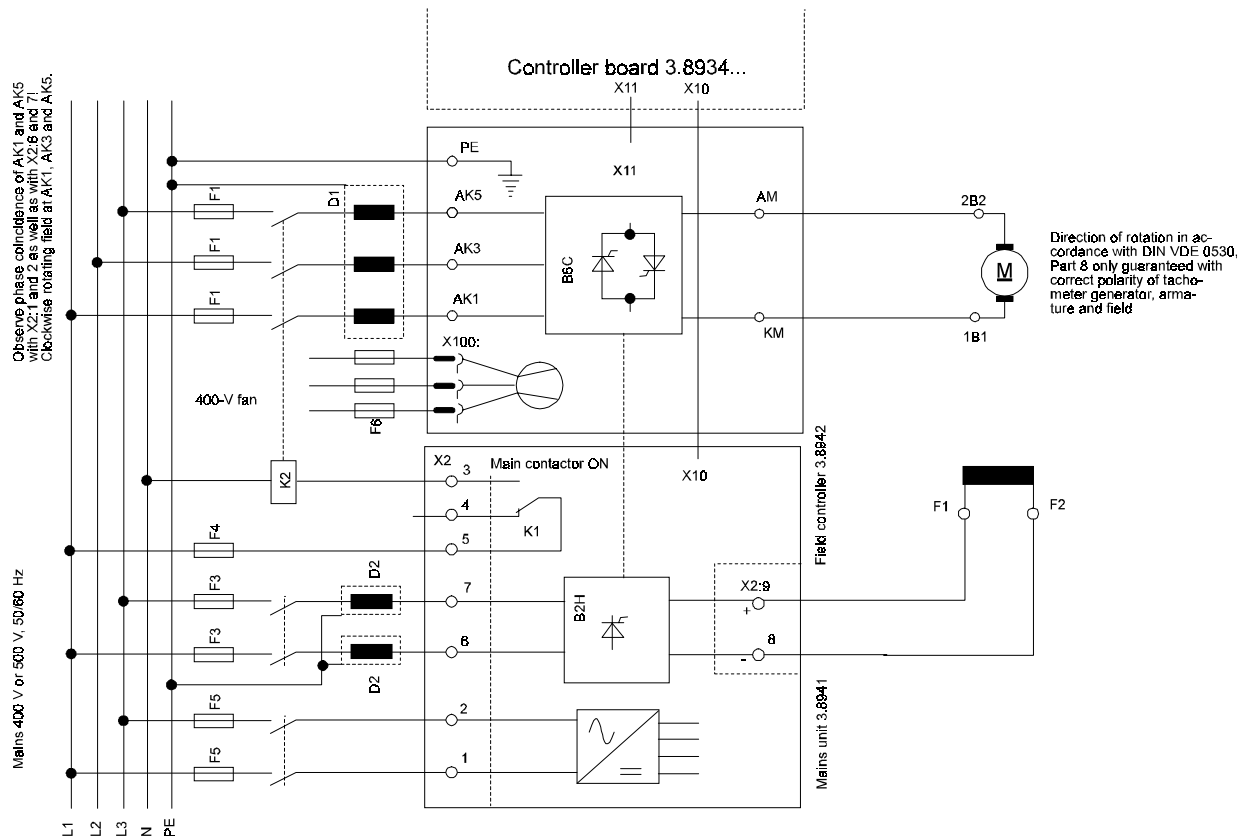

with 25-A Field Supply

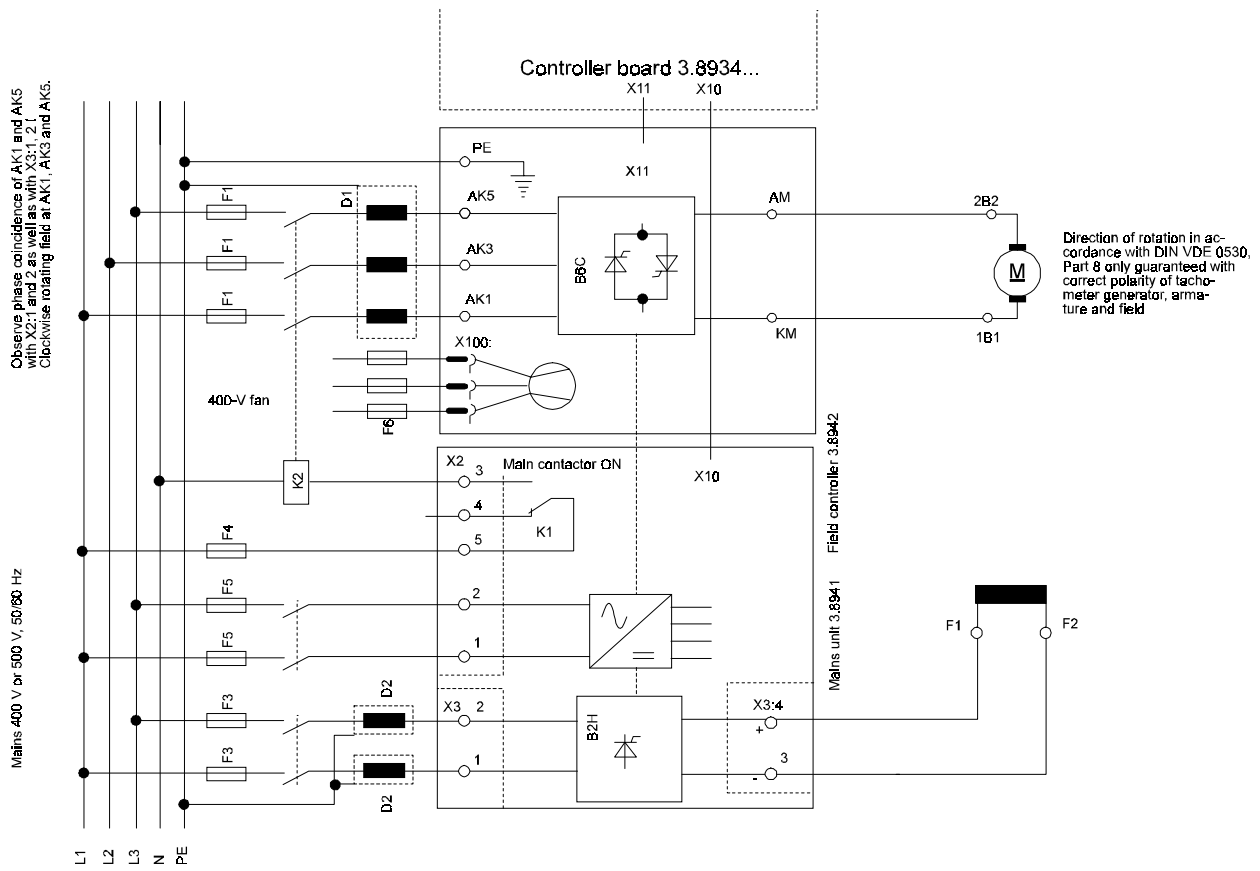

- **Connecting Power Stage BKD 6/6000 Size III**
with Field Supply for 15 A max.

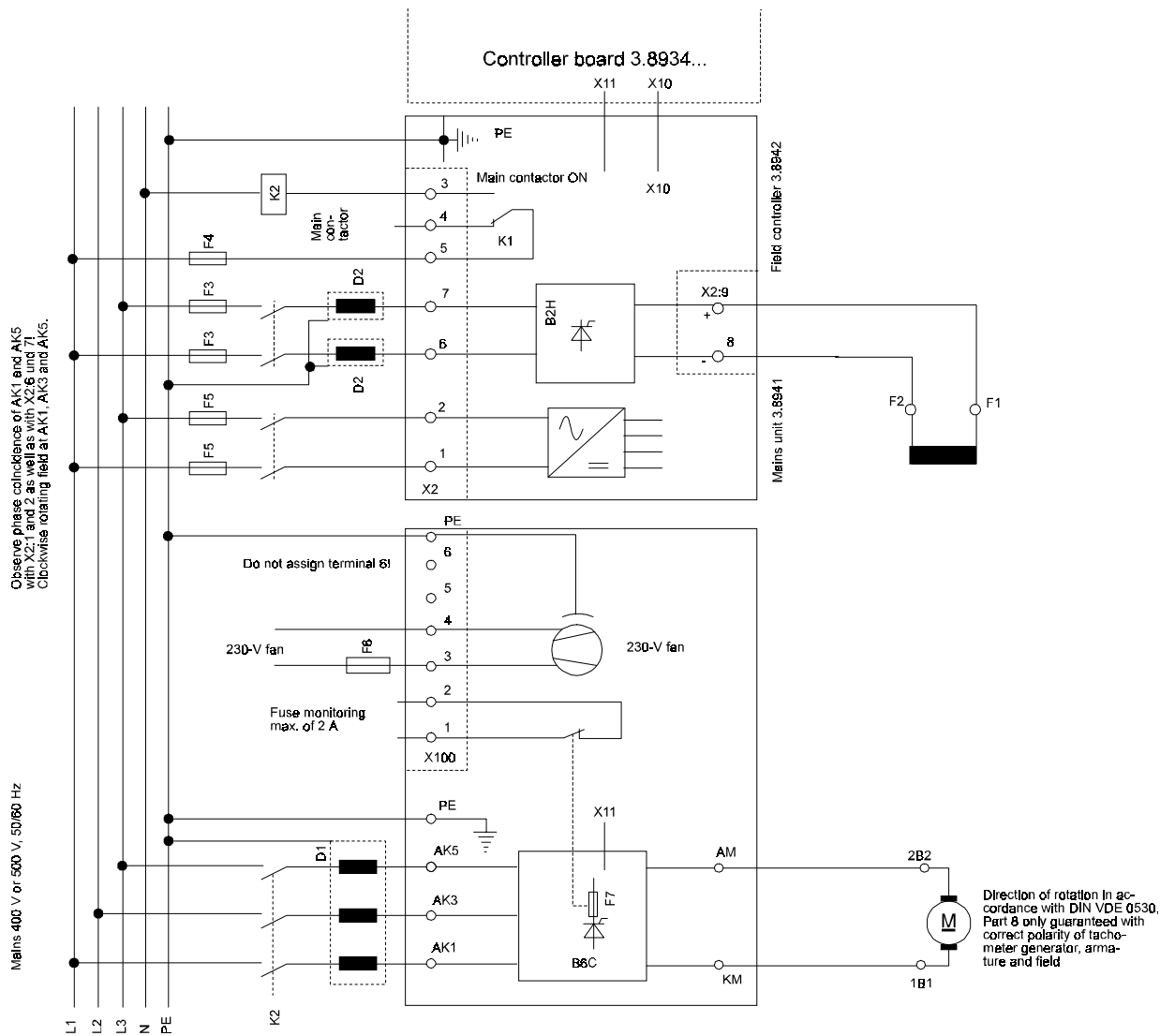

- **Connecting Power Stage BKD 6/6000 Size IV**
with Field Supply for 15 A max.

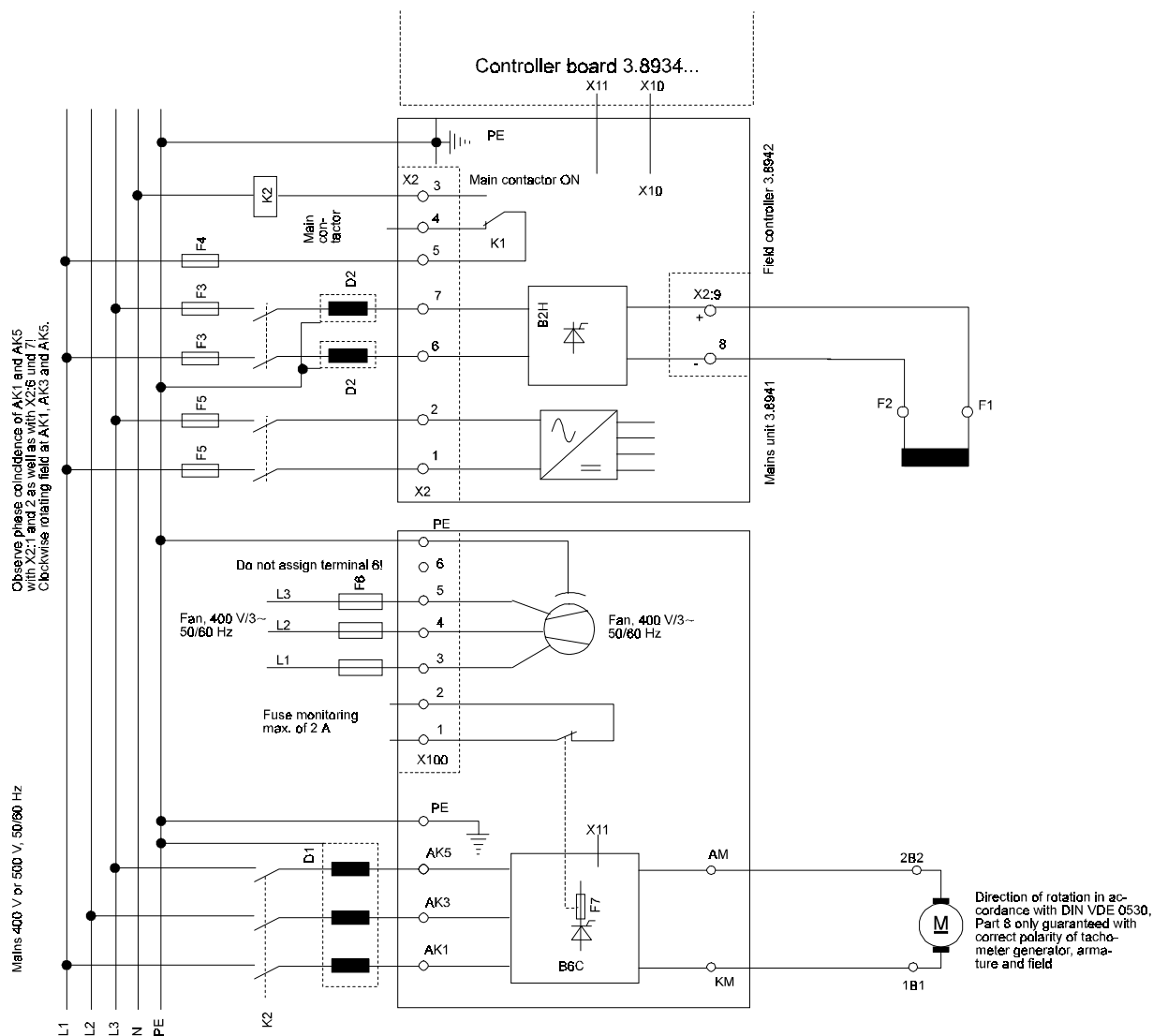

with 25-A Field Supply

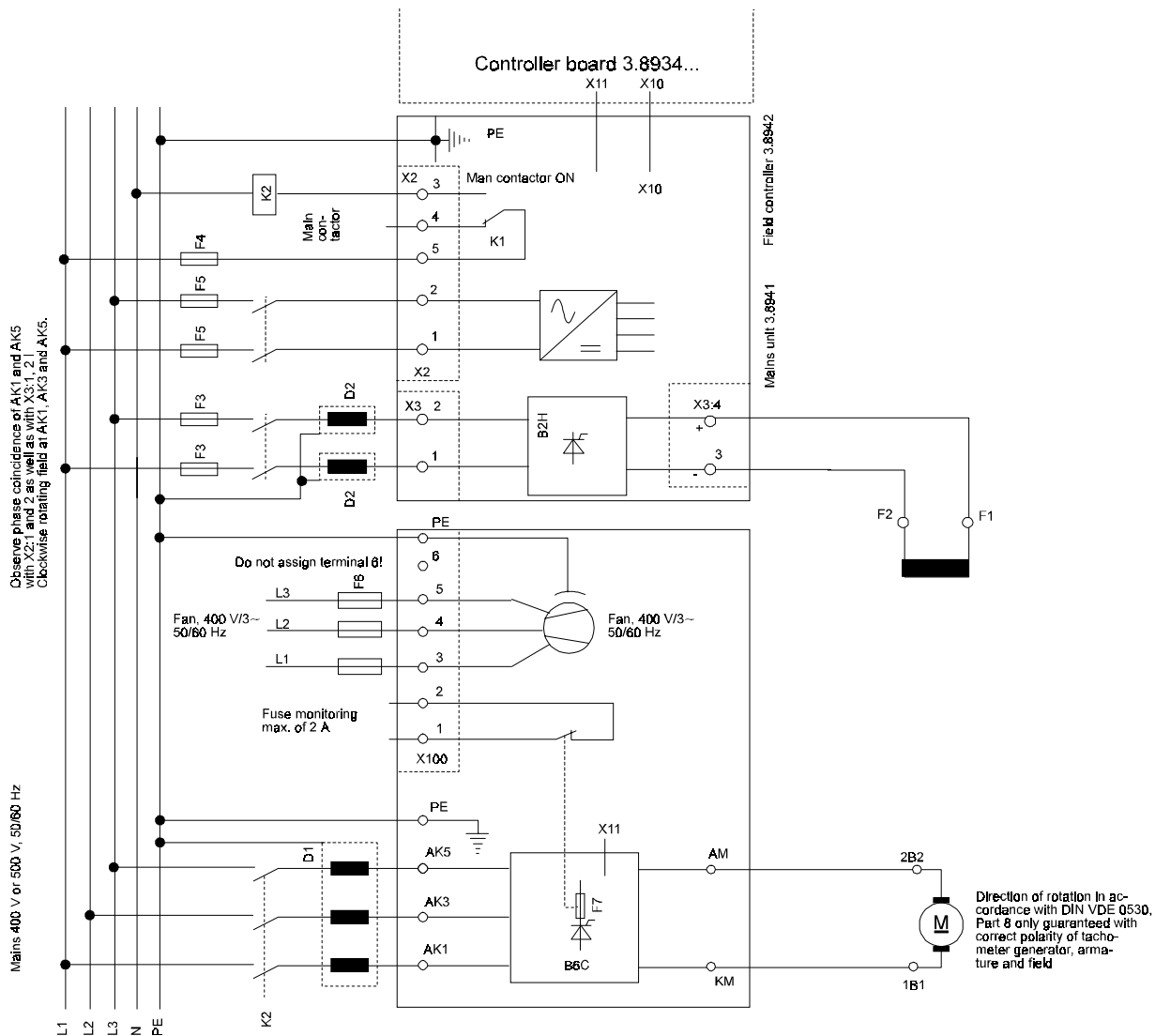

Connection Information

X2	Terminal strip	Terminal cross-section 0.2 ... 2.5 mm ²
X3	Terminal strip	Terminal cross-section 0.5 ... 4.0 mm ²
F1	Sizes 1 and 2: Size 3:	Phase fuses, refer to 5.6 Arm-circuit fuses integrated in the thyristor set, use original-manufacturer semiconductor fuses only, due to this, there are no fuses in the phase and armature circuits, see section 5.4.
F2	Armature circuit fuses	For recommendations, refer to 5.6 With BKD power converters, armature circuit fuses F2 are eliminated.
K2	Main contactor	If operated in the deenergized condition, deenergizes the power stage (armature).
D1	Three-phase current line commutator	For recommendations, refer to line commutators, reduces the power converter's feedback effect on the feed mains and protects the thyristors from impermissible rates of current rise (VDE 0160). The stated rated currents are referred to the direct current side, see Section 5.5.
L1, L2, L3	Connection lines	Cross-section acc. to DIN EN 60204 Part 1/VDE 0113 Part 1/06.93, Sections 14 and 15, Appendix C, or VDE 0298/Part 4
1B1, 2B2	Motor connections	Cross-section acc. to DIN EN 60204 Part 1/VDE 0113 Part 1/06.93, Sections 14 and 15, Appendix C, or VDE 0298/Part 4, connection 1B1 is positive with a clockwise-rotating shaft
PE	Protective earth connection	Cross-section acc. to DIN EN 60204 Part 1/VDE 0113 Part 1/06.93, Section 8.2.2, taking into account provisional standard EN 50178/VDE 0160/11.94, Sections 5.3.2.1 and 8.3.4.4 For the connection screw, refer to the dimensional drawing
AK1, AK3, AK5	Connections of the thyristor set	By means of choke D1, mains contactor K2 (and with sizes I and II by means of the phase fuses) connect L1, L2, L3 to the three-phase mains. Observe the clockwise-rotating field and phase coincidence with mains units X2:1 and X2:2! For the connection screws, refer to the dimensional drawings.
AM, KM	Motor connections	KM is positive with a clockwise-rotating motor
F3	Semiconductor fuse in the field connection	Two 5SD4.. 16 A ... 30 A/500 V~ screwed-type fuses, depending on the field current converter's rated current, refer to 5.6 Semiconductor Fuses
F4	Power protection	Rating depends on main contactor K1
F5	Power protection	0.4 A MTL/500 V fuse or 0.4 ... 0.63 A motor protection switch

Fan Connection		
	Size I	30 A unventilated 50 A and above: no external connection, since the fan is supplied internally
X100	Size II	400 V, 3~, 50/60 Hz, 0.23/0.30 A AMP plug-in connector for 0.5 ... 2.1 mm ² (contained in the included accessories); observe the direction of rotation. Ignoring the direction of rotation may lead to the equipment overheating.
X100:3,4	Size III	230 V, 1~, 0.94 A at 50/60 Hz Terminal strip for 0.5 ... 2.5 mm ²
X100:3,4,5	Size IV	400 V, 3~, 1.2 A at 50 Hz, 1.5 A at 60 Hz Terminal strip for 0.5 ... 2.5 mm ² Observe the direction of rotation. Ignoring the direction of rotation may lead to the equipment overheating.
X100:PE	Sizes III and IV Size II	Protective earth connection for the fan. The protective earth is wired inside the unit.
X100:6		Do not assign this terminal
X100:1,2	Fuse monitoring	With power stages of sizes III and IV only, Contacts can be loaded with a maximum of 250 V~, 2 A or 30 V ₋ , 2 A, and a minimum of 24 V ₋ /100 mA
F6	Back-up fuse for fan	Size II: 3 x 400 mA MTL or 0.24 ... 0.4 A motor protection switch Size III: 1 x 1.6 A MTL or 1.00 ... 1.6 A motor protection switch Size IV: 3 x 1.6 A MTL or 1.00 ... 1.6 A motor protection switch
F7	Arm-circuit fuses	With power stages of sizes III and IV only: Protection of the disk-type thyristors the fuses are integrated in the thyristor set.
X2:8,9 or X3:3,4	Field connection	Connection of F1 to X2:9 or X3:4 (+), connection of F2 to X2:8 or X3:3 (-) of the field and controller supply
F1, F2	Connection of field winding	Cross-section acc. to DIN EN 60204 Part 1/VDE 0113 Part 1/06.93, Sections 14 and 15, Appendix C, or VDE 0298/Part 4, connection F1 is positive with a clockwise-rotating shaft.
D2	Field line commutator	One line commutator in each feed line, rating in accordance with the field device's rated current, refer to Section 5.5
X2:1,2	Connection of mains unit	Observe phase coincidence with AK1 and AK5, avoid phase shifts between L1 and X2:1, since the firing pulses for the power stages of the field and the armature are synchronized from the mains unit.

X2:3,4,5	Control of main contactor K1	Relay contacts that can be loaded with 230 V/1 A~ or 24V/1 A _L (non-inductive load); the "main contactor ON" relay is activated by the control command at terminal X1:22.
X2:6,7 or X3:1,2	Connections of the field power stage	Connect in-phase to the mains unit at L1 and L3, cross-section according to DIN EN 60204 Part 1/VDE 0113 Part 1/06.93/Sections 14 and 15, Appendix C or VDE 0298/Part 4.

5.4 Connecting Daughterboards

5.4.1 "Dual DAC 12", 3.9201 Daughterboard

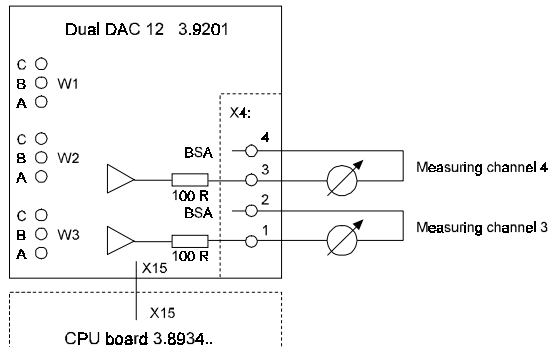

Terminal strip X4:

Terminal block

Terminal cross-section 0.2 ... 2.5 mm²

X4: 1,2 Measuring channel 3 0 .. ± 10 V, max. of 4 mA, selection of test point using P130; resolution approx. 10 mV, use screened cables.

X4: 3,4 Measuring channel 4 0 .. ± 10 V, max. of 4 mA, selection of test point using P131; resolution approx. 10 mV, scaling using P132 possible, use screened cables.

Jumper assignment:

You can fit up to two daughterboards on the power converter.

The way jumpers W2 and W3 are fitted specifies the address of the PCB on the unit:

- W2:A-B and W3:A-B
3.9201 is the only supplementary module
- W2:B-C and W3:B-C
3.9201 is the second supplementary module

Up to motherboard 3.8934 C, W1 must be jumpered to B-C, with 3.8934 D and above, W1 must be jumpered to A-B.

Resistance networks RN1 to RN4 function as bus terminators.

If there are two supplementary modules, and PCB 3.9201 is mounted as the bottom card, you must remove resistance networks RN1 to RN4 (fitted on skirting ducts).

5.4.2 "Input/Output Expansion", 3.9217 Daughterboard

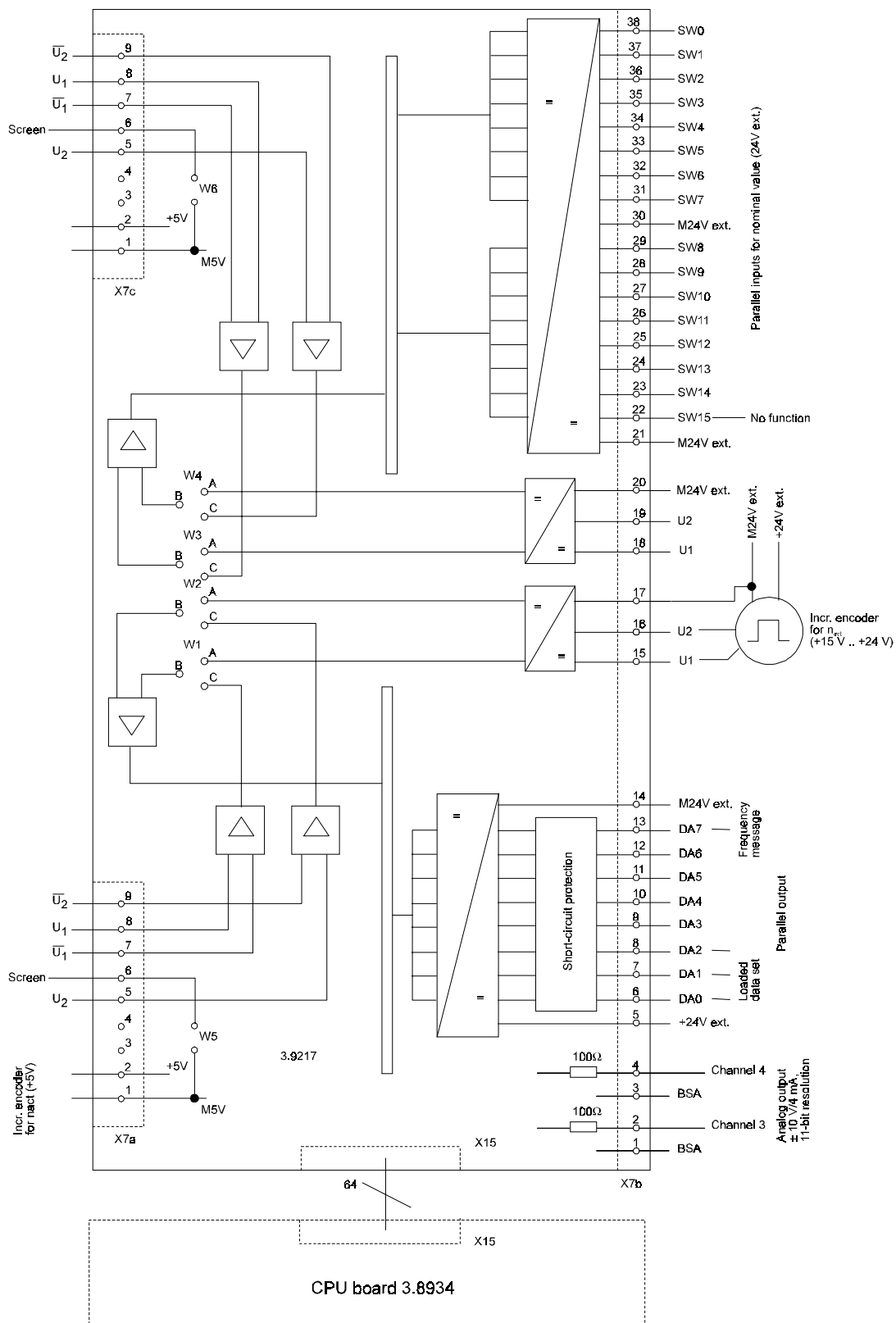

NOTE

Terminals M24V ext. (X7b: 14, 17, 20, 21, 30) have no electrical connection on the PCB!

Pin assignment

X7a: 15-pin SUB-D socket connector
 Incremental encoder input for speed measurement with +5-V supply for two 90° phase-shifted differential impulses
 Signal level: LOW signal = 0 ... 0.45 V, HIGH signal = 2.4 V ... 5.25 V

Pin No.	Assignment
1	Ground
2	+5V (internal power supply)
3	Not assigned
4	Not assigned
5	Incremental encoder +U2
6	Screen
7	Incremental encoder -U1
8	Incremental encoder +U1
9	Incremental encoder -U2
10 ... 15	Not assigned

X7b: Terminal blocks
 Terminal cross-section 0.2 mm² ... 2.5 mm²

X7b:1, 2 Measuring channel 3
 0 ... ±10 V, max. of 4 mA, selection of test point using P130; resolution approx. 10 mV, use screened cables.

X7b:3, 4 Measuring channel 4
 0 ... ±10 V, max. of 4 mA, selection of test point using P131; resolution approx. 10 mV, scaling using P132 possible, use screened cables.

X7b:5-14 8 digital outputs
 isolated; each can be loaded with 35 V/100 mA

X7b:15-17 Incremental encoder input for speed measurement
 with +24-V supply for two 90° phase-shifted differential impulses
 Signal level: LOW signal = 0 ... 4 V, HIGH signal = +15 V ... +30 V
 $R_i = 3 \text{ k}\Omega$. The power supply must be external.

X7b:18-20 Incremental encoder input for speed nominal value setting (in preparation)
 with +24-V supply for two 90° phase-shifted differential impulses
 Signal level: LOW signal = 0 ... 4 V, HIGH signal = +15 V ... +30 V
 $R_i = 3 \text{ k}\Omega$. The power supply must be external.
 The software does not support this.

X7b:21-38 16 digital inputs for digital nominal value assignment; isolated via optocoupler
 Signal level: LOW signal = 0 ... 4 V, HIGH signal = +15 V ... +30 V
 $R_i = 3 \text{ k}\Omega$. The power supply must be external.

X7b:

	Pin No.	Assignment
Analog Outputs	1	BSA (internal reference voltage)
	2	Analog channel 3
	3	BSA (internal reference voltage)
	4	Analog channel 4
Digital Outputs	5	+24 V ext.
	6	DA0
	7	DA1
	8	DA2
	9	DA3
	10	DA4
	11	DA5
	12	DA6
	13	DA7
	14	M24 V ext.
Incremental encoder input for speed measurement	15	U1 actual value incr. with ext. +24-V supply.
	16	U2 actual value incr. with ext. +24-V supply
	17	Ext. reference voltage for actual value incr. with ext. +24-V supply.
Incremental encoder input for speed nominal value setting (the software does not support this)	18	U1 nominal value incr. with ext. +24-V supply
	19	U2 nominal value incr. with ext. +24-V supply
	20	Ext. reference voltage for nominal value incr. with ext. +24-V supply.
Digital nominal value setting	21	Ext. reference voltage for SW8-SW15
	22	No function
	23	SW14 (sign bit)
	24	SW13
	25	SW12
	26	SW11
	27	SW10
	28	SW9
	29	SW8
	30	(Ext. reference voltage for SW0-SW7
	31	SW7
	32	SW6
	33	SW5
	34	SW4
	35	SW3
	36	SW2
	37	SW1
	38	SW0

X7c: 15-pin SUB-D socket connector
 Incremental encoder input for speed nominal value assignment with +24-V supply for two 90° phase-shifted differential impulses (in preparation)
 Signal level: LOW signal = 0 ... 0.45 V, HIGH signal = 2.4 V ... 5.25 V

Pin No.	Assignment
1	Ground
2	+5V (internal power supply)
3	Not assigned
4	Not assigned
5	Incremental encoder +U2
6	Screen
7	Incremental encoder -U1
8	Incremental encoder +U1
9	Incremental encoder -U2
10 ... 15	Not assigned

Not supported by the software!

Plug-in jumpers

Using jumpers W1 and W2, you choose between actual value incremental encoders with an internal +5-V supply (X7a) and actual value incremental encoders with an external +24-V supply (X7b:15-17):

- W1 and W2: A-B Actual value incremental encoder with an external +24-V supply
- W1 and W2: B-C Actual value incremental encoder with an internal +5-V supply

Using jumpers W3 and W4 you choose between nominal value incremental encoders with an internal +5-V supply (X7c) and nominal value incremental encoders with an external +24-V supply (X7b:18-20):

- W3 and W4: A-B Nominal value incremental encoder with an external +24-V supply
 - W3 and W4: B-C Nominal value incremental encoder with an internal +5-V supply
- Not supported by the software!

Jumper W5 connects the screen of X7a (pin 6) to the electronic potential (M5V) with jumper W6 connecting the screen of X7c (Pin 6) to the electronic potential (M5V).

The way jumpers W7 and W8 are fitted specifies the address of the PCB on the unit:

- W7 and W8:A-B 3.9217 is the only supplementary module
- W7 and W8:B-C 3.9201 is the second supplementary module

Up to motherboard 3.8934 C, W9 must be jumpered to B-C, with 3.8934 D and above, W9 must be jumpered to A-B.

Resistance networks RN3 to RN8 function as bus terminators.

If there are two supplementary modules, and PCB 3.9217 is mounted as the bottom card, you must remove resistance networks RN3 to RN8.

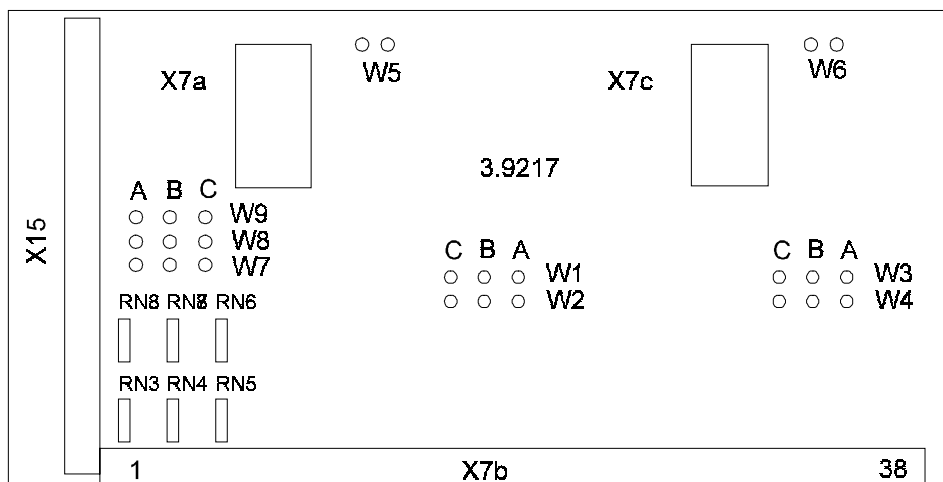

5.4.3 InterBus-S Interface Board

For PCB 3.9208, refer to supplementary description.

Pin assignment:

InterBus-S IN X8b: 15-pin SUB-D plug connector

Pin No.	Assignment
1	UVO + 9 V
2	UVO + 9 V
3	Not assigned
4	Not assigned
5	SLI1 Select Line IN1
6	CKI1 Clock Line IN1
7	CRI1 Control Line IN1
8	DI1 Data Line IN1
9	Ground
10	Ground
11	ResIn Reset IN
12	SLO1 Select Line OUT1
13	CKO1 Clock Line OUT1
14	CRO1 Control Line OUT1
15	DO1 Data Line OUT1

InterBus-S OUT X8c: 15- pin SUB-D socket connector

Pin No.	Assignment
1	UVO + 9 V
2	UVO + 9 V
3	+ 5 V Connector identification
4	+ 5 V Connector identification
5	SLI2 Select Line IN2
6	CKI2 Clock Line IN2
7	CRI2 Control Line IN2
8	DI2 Data Line IN2
9	Ground
10	Ground
11	LBRes Reset OUT
12	SLO2 Select Line OUT2
13	CKO2 Clock Line OUT2
14	CRO2 Control Line OUT2
15	DO2 Data Line OUT2

RS485 X3: 9-pin SUB-D socket connector

Pin No.	Assignment
1	-TxD
2	+5V
3	Ground
4	Ground
5	-RxD
6	+RxD
7	Ground
8	Ground
9	+TxD

X4: 9-pin SUB-D plug connector
 identical with X3
 X3 and X4 are connected in-parallel!

5.4.5 RS485 with USS Protocol or as a CS31 System Bus Interface, 3.9493

For PCB 3.9493, refer to supplementary description.

Pin assignment:

CS31 (PCB versions 3.9493.01 and 3.9493.02)

X601: 9-pin SUB-D plug connector
 X602: 9-pin SUB-D socket connector
 X601 and X602 are electrically connected in-parallel

Pin No.	Assignment
1	Screen
2 ... 4	Not assigned
5	BUS2
6	BUS1
7 ... 9	Not assigned
Housing	Screen

USS protocol (PCB versions 3.9493.03 and 3.9493.04)

X601: 9-pin SUB-D plug connector

X602: 9-pin SUB-D socket connector

X601 and X602 are electrically connected in-parallel

Pin No.	Assignment
1	-TxD
2	+5V
3	Ground
4	Ground
5	-RxD
6	+RxD
7	Ground
8	Ground
9	+TxD

X603: 2-pin print terminal for 1-mm² terminal cross-section:
PE terminal

Incremental encoder (PCB versions 3.9493.02 and 3.9493.04)

X8: 15-pin SUB-D plug connector

X9: 15-pin SUB-D socket connector

X8 and X9 are electrically connected in-parallel

Incremental encoder input for speed measurement with +5-V supply for two 90° phase-shifted differential impulses

Signal level: LOW signal: 0 ... 0.45 V, HIGH signal: 2.4 ... 5.25 V

Pin No.	Assignment
1	Ground
2	+5V (internal power supply)
3	Not assigned
4	Not assigned
5	Incremental encoder +U2
6	Screen
7	Incremental encoder -U1
8	Incremental encoder +U1
9	Incremental encoder -U2
10 ... 15	Not assigned

5.5 Position of the Electrical Connections and Modules

5.5.1 BKD 6 and BKF 12 .../6000, Size I (30 A to 200 A)

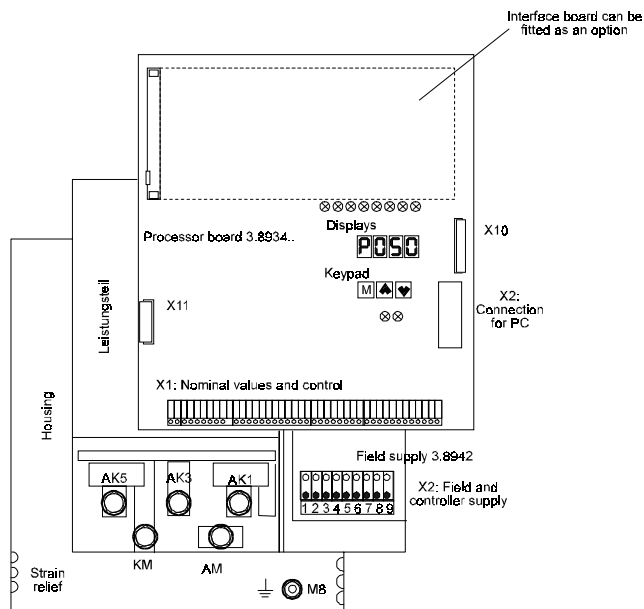

5.5.2 BKD 6 and BKF 12 .../6000, Size II (300 A to 600 A)

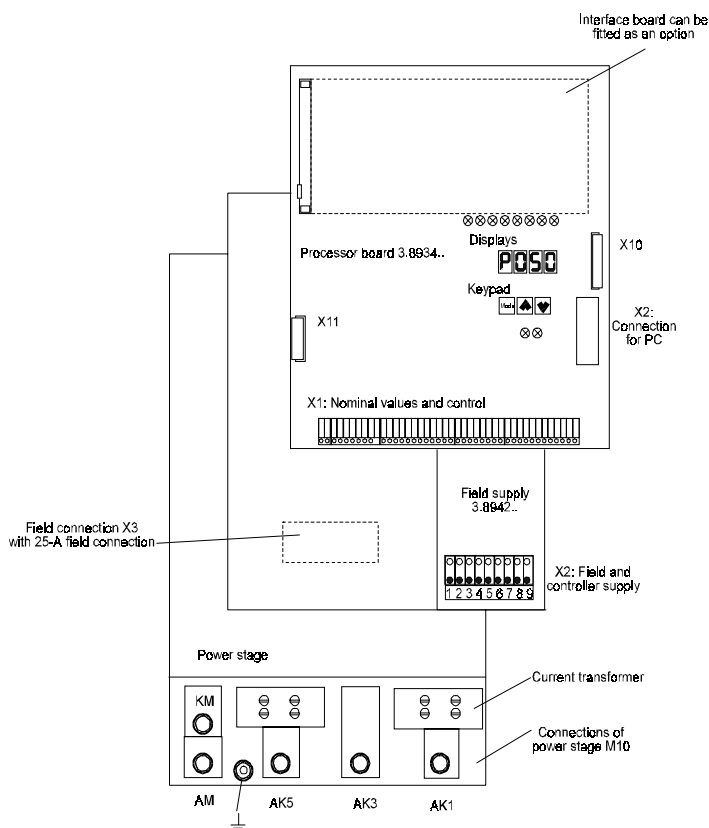

5.5.3 Controller and Field Supply for Sizes III and IV (750 A to 2050 A)

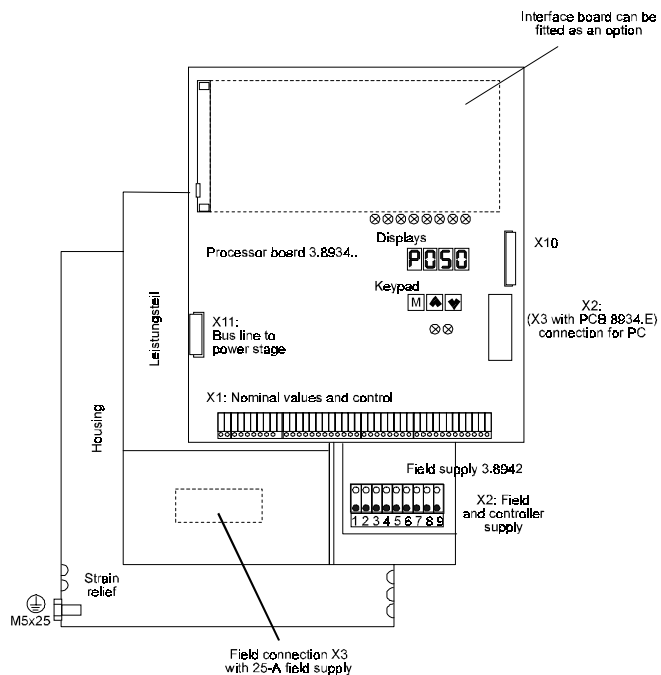

5.6 Semiconductor Fuses

NOTE

Safe protection of the power stage cannot be guaranteed if you use fuses that are not listed!

To protect the thyristors, you must connect super-high speed semiconductor fuses in the three-phase current supply line.

With sizes I and II, the semiconductor fuses on the mains side (phase fuses) must be arranged outside the power converter in the control cabinet. In the case of the BKF, you must additionally consider the armature circuit fuses.

Unit sizes III and IV have arm-circuit fuses that are integrated in the equipment.

5.6.1 Unit Size I

- a) Connection voltage 3 x 400 V
Manufacturer: SIEMENS

Power Converter Type BKD or BKF	Phase Current (eff)	Rated DC Current	Phase Fuse	Nominal Current/Nominal Voltage	Order No. 1900...	Armature Circuit Fuse (with BKF power converters only)	Nominal Current/Nominal Voltage	Order No. 1900...
BK.../30/400-6...	24.6 A	30 A	3NE8 003 3NE4 101	35 A/660 V 32 A/1000 V	8566 8528	3NE8 003 3NE4 101	35 A/660 V 32 A/1000 V	8566 8528
BK.../50/400-6...	41.0 A	50 A	3NE8 017 3NE4 117	50 A/660 V 50 A/1000 V	8567 8529	3NE8 018 3NE4 118	63 A/660 V 63 A/1000 V	8575 8530
BK.../70/400-6...	57.4 A	70 A	3NE4 118	63 A/1000 V	8530	3NE4 120	80 A/1000 V	8531
BK.../100/400-6...	82.0 A	100 A	3NE8 021 3NE4 121	100 A/660 V 100 A/1000 V	8573 8526	3NE8 022 3NE4 122	125 A/660 V 125 A/1000 V	8576 8532
BK.../120/400-6...	98.4 A	120 A	3NE8 022 3NE4 122	125 A/660 V 125 A/1000 V	8576 8532	3NE8 024 3NE4 124	160 A/660 V 160 A/1000 V	8700 8545
BK.../150/400-6...	123.0 A	150 A	3NE8 024 3NE4 124	160 A/660 V 160 A/1000 V	8700 8545	3NE8 024 3NE4 124	160 A/660 V 160 A/1000 V	8700 8545
BK.../200/400-6...	164.0 A	200 A	3NE4 327-0B	250 A/800 V	8619	3NE4 327-0B	250 A/800 V	8619

Manufacturer: SIBA

Power Converter Type BKD or BKF	Phase Current (eff)	Rated DC Current	Phase Fuse	Nominal Current/Nominal Voltage	Order No. 1900...	Armature Circuit Fuse (with BKF power converters only)	Nominal Current/Nominal Voltage	Order No. 1900...
BK.../30/400-6...	24.6 A	30 A	2038404/32	32 A/1000 V	8528	2038404/50	50 A/1000 V	8529
BK.../50/400-6...	41.0 A	50 A	2038404/50	50 A/1000 V	8529	2038404/63	63 A/1000 V	8530
BK.../70/400-6...	57.4 A	70 A	2038404/63	63 A/1000 V	8530	2038404/80	80 A/1000 V	-
BK.../100/400-6...	82.0 A	100 A	2038404/100	100 A/1000 V	8526	2038404/125	125 A/1000 V	8532
BK.../120/400-6...	98.4 A	120 A	2038404/125	125 A/1000 V	8532	2038404/160	160 A/1000 V	8545
BK.../150/400-6...	123.0 A	150 A	2038404/160	160 A/1000 V	8545	-	-	-
BK.../200/400-6...	164.0 A	200 A	-	-	-	-	-	-

b) Connection voltage 3 x 500 V

Manufacturer: SIEMENS

Power Converter Type BKD or BKF	Phase Current (eff)	Rated DC Current	Phase Fuse	Nominal Current/Nominal Voltage	Order No. 1900...	Armature Circuit Fuse (with BKF power converters only)	Nominal Current/Nominal Voltage	Order No. 1900...
BK.../30/520-6...	24.6 A	30 A	3NE4 101	32 A/1000 V	8528	3NE4 101	32 A/1000 V	8528
BK.../50/520-6...	41.0 A	50 A	3NE4 117	50 A/1000 V	8529	3NE4 118	63 A/1000 V	8530
BK.../70/520-6...	57.4 A	70 A	3NE4 120	80 A/1000 V	8531	3NE4 120	80 A/1000 V	8531
BK.../100/520-6...	82.0 A	100 A	3NE4 121	100 A/1000 V	8526	3NE4 122	125 A/1000 V	8532
BK.../120/520-6...	98.4 A	120 A	3NE4 122	125 A/1000 V	8532	3NE4 124	160 A/1000 V	8545
BK.../150/520-6...	123.0 A	150 A	3NE4 122	125 A/1000 V	8532	3NE4 124	160 A/1000 V	8545
BK.../200/520-6...	164.0 A	200 A	3NE4 327-0B	250 A/800 V	8619	3NE4 327-0B	250 A/800 V	8619

Manufacturer: SIBA

Power Converter Type BKD or BKF	Phase Current (eff)	Rated DC Current	Phase Fuse	Nominal Current/Nominal Voltage	Order No. 1900...	Armature Circuit Fuse (with BKF power converters only)	Nominal Current/Nominal Voltage	Order No. 1900...
BK.../30/520-6...	24.6 A	30 A	2038404/32	32 A/1000 V	8528	2038404/50	50 A/1000 V	8529
BK.../50/520-6...	41.0 A	50 A	2038404/50	50 A/1000 V	8529	2038404/63	63 A/1000 V	8530
BK.../70/520-6...	57.4 A	70 A	2038404/63	63 A/1000 V	8530	2038404/80	80 A/1000 V	-
BK.../100/520-6...	82.0 A	100 A	2038404/100	100 A/1000 V	8526	2038404/125	125 A/1000 V	8532
BK.../120/520-6...	98.4 A	120 A	2038404/125	125 A/1000 V	8532	2038404/160	160 A/1000 V	8545
BK.../150/520-6...	123.0 A	150 A	2038404/160	160 A/1000 V	8545	-	-	-
BK.../200/520-6...	164.0 A	200 A	-	-	-	-	-	-

5.6.2 Unit Size II

Connection Voltage 3 x 400 V
3 x 500 V

Manufacturer: SIEMENS

Power Converter Type BKD or BKF	Phase Current (eff)	Rated DC Current	Phase Fuse	Nominal Current/Nominal Voltage	Order No. 1900...	Armature Circuit Fuse (with BKF power converters only)	Nominal Current/Nominal Voltage	Order No. 1900...
BK.../300/...-6...	246.0 A	300 A	3NE3 230-0B	315 A/1000 V	8620	3NE3 230-0B	315 A/1000 V	8620
BK.../400/...-6...	328.0 A	400 A	3NE3 231	350 A/1000 V	8621	3NE3 233	450 A/1000 V	8622
BK.../500/...-6...	410.0 A	500 A	3NE3 334-0B	500 A/1000 V	8623	3NE3 335	560 A/1000 V	8624
BK.../600/...-6...	492.0 A	600 A	3NE3 335	560 A/1000 V	8624	3NE3 336	630 A/1000 V	8625

5.6.3 Unit Size III

With unit size III, arm circuit fuses are used that are integrated in the power converter's power stage.

Connection voltage 3 x 400 V
3 x 500 V

Manufacturer: Ferraz

Power converter type	Current of an Arm (eff)	Rated DC Current	Arm-Circuit Fuse	Nominal Current/Nominal Voltage	Order No. 1900...
BKD6/750/...-6...	433 A	750 A	6.6 URD 32 TTF 0500	500 A	-
BKD6/920/...-6...	531 A	920 A	6.6 URD 32 TTF 0630	630 A	-
BKD6/1100/...-6...	635 A	1100 A	6.6 URD 32 TTF 0700	700 A	-
BKF6/850/...-6...	491 A	850 A	6.6 URD 32 TTF 0630	630 A	-

5.6.4 Unit Size IV

With unit size IV, arm circuit fuses are used that are integrated in the power converter's power stage.

Connection voltage 3 x 400 V
 3 x 500 V

Manufacturer: Ferraz

Power converter type	Current of an Arm (eff)	Rated DC Current	Arm-Circuit Fuse	Nominal Current/Nominal Voltage	Order No. 1900...
BKD6/1550/...-6...	895 A	1550 A	6,6 URD 33 TTF 1000	1000 A	-
BKD6/1750/...-6...	1010 A	1750 A	6,6 URD 33 TTF 1250	1250 A	-
BKD6/2050/...-6...	1184 A	2050 A	6,6 URD 32 TTF 0700 2 parallel	700 A	-
BKF12/1250/...-6...	722 A	1250 A	6,6 URD 33 TTF 1000	1000 A	-
BKF12/1400/...-6...	808 A	1400 A	6,6 URD 33 TTF 1000	1000 A	-
BKF12/1650/...-6...	953 A	1650 A	6,6 URD 33 TTF 1100	1100 A	-

5.6.5 Fuse Sizes

Manufacturer: SIEMENS

3NE8.. Size 00, DIN 43620
 3NE4 1.. Size 0, DIN 43620
 3NE4 3..-0B Size 2, inside dimension 110 mm
 3NE3 2.. Size 1, inside dimension 110 mm
 3NE3 3.. Size 2, inside dimension 110 mm

Manufacturer: SIBA

2038404 Size 0 DIN 43620

5.6.6 Field Semiconductor Fuses

Connection voltage: 2 x 400 V
 2 x 500 V

5 SD 420 16 A/500 V Size E27
 5 SD 430 20 A/500 V Size E27
 5 SD 440 25 A/500 V Size E27
 5 SD 480 30 A/500 V Size E27

5.7 Line Commutators

In accordance with VDE 0160, you must install a line commutator between the power converter and the mains.

The line commutator protects the thyristors from impermissible rates of current rise and reduces the power converter's feedback effect on the feed mains.

- Three-phase current line commutators for 400 V connection voltage; $U_N = 400 \text{ V } 50/60 \text{ Hz}$, $T_A = 55^\circ\text{C}$, $U_K = 4\%/4.8\%$ with flat terminal, IP00

Commutator DR3-40-4	Rated DC Current A	a mm	b mm	c mm	d mm	e mm	f x g mm	Flat Terminal Diameter mm x mm	Dim. Drwg.	Weight kg	Losses W	Internal Identifier 1900 ..
- 0035	35	150	105	130	113	65	5.8 x 11	Diameter 7	A1	6.0	45	- 7466
- 0040	40	150	105	130	113	65	5.8 x 11	Diameter 7	A1	6.0	50	- 7467
- 0050	50	150	105	130	113	65	5.8 x 11	Diameter 7	A1	6.0	55	- 7468
- 0080	80	180	130	158	136	75	7 x 14	Terminals 35 mm ²	A2	9.8	65	- 7822
- 0100	100	225	125	200	176	73	7 x 13	Diameter 9	A1	12.7	90	- 7471
- 0120	120	225	125	200	176	71	7 x 13	Diameter 9	A1	13.0	100	- 7472
- 0160	160	240	165	210	220	120	9 x 14	25 x 4/Diam. 11	A1	19.0	105	- 7473
- 0200	200	310	170	255	280	106	11 x 18	25 x 4/Diam. 11	A1	28.0	120	- 7474
- 0300	300	310	220	260	280	131	11 x 18	40 x 4/Diam. 14	A1	50.0	170	- 7475
- 0400	400	310	220	260	280	131	11 x 18	40 x 4/Diam. 14	A1	50.0	180	- 7476
- 0500	500	420	260	260	380	161	11 x 18	40 x 8/Diam. 14	A1	70.0	185	- 7477
- 0600	600	420	260	260	380	161	11 x 18	40 x 8/Diam. 14	A1	70.0	300	- 7478
- 0750	750	520	230	400	470	120	11 x 18	50 x 10/2x Diam. 14	A3	110.0	350	- 7479
- 1050	1050	520	240	405	470	150	11 x 18	50 x 10/2x Diam. 14	A3	130.0	400	- 7480

- Three-phase current line commutators for 500 V connection voltage; $U_N = 420 \text{ V ... } 500 \text{ V}$, 50/60 Hz, $T_A = 55^\circ\text{C max.}$, $U_K = 4\%/4.8\%$ with flat terminal, IP00

Commutator DR3-50-4	Rated DC Current A	a mm	b mm	c mm	d mm	e mm	f x g mm	Flat Terminal Diameter mm x mm	Dim. Drwg.	Weight kg	Losses W	Internal Identifier 1900 ..
- 0030	30	150	105	130	113	65	5.8 x 11	Diameter 7	A1	6.1	30	- 7481
- 0050	50	180	130	155	136	75	7 x 14	Diameter 7	A1	9.8	50	- 7482
- 0070	70	230	125	200	176	70	7 x 14	Diameter 9	A1	13.0	65	- 7483
- 0100	100	230	125	200	176	70	7 x 13	Diameter 9	A1	13.5	85	- 7484
- 0120	120	240	140	210	200	80	8.5	25 x 3/Diam. 9	A1	16.8	95	- 7485
- 0150	150	240	160	210	200	100	8.5	25 x 3/Diam. 11	A1	20.5	95	- 7486
- 0200	200	270	170	230	200	102	10 x 18	30 x 4/Diam. 11	A1	27.5	135	- 7487
- 0300	300	300	210	265	240	125	9 x 14	30 x 5/Diam. 14	A1	47.5	170	- 7488
- 0400	400	360	230	315	300	150	9 x 14	40 x 5/Diam. 14	A1	73.0	225	- 7489
- 0600	600	470	240	370	320	155	9 x 14	40 x 8/Diam. 14	A1	95.0	315	- 7490
- 0800	800	520	240	410	470	150	9 x 14	50 x 10/2x Diam. 14	A3	110.0	365	- 7491
- 1000	1000	480	300	420	360	170	14 x 19	50 x 10/2x Diam. 14	A3	140.0	445	- 7492

Dimensional Drawings and Diagrams of Connections

Dimensional drawing and diagram of connections A1

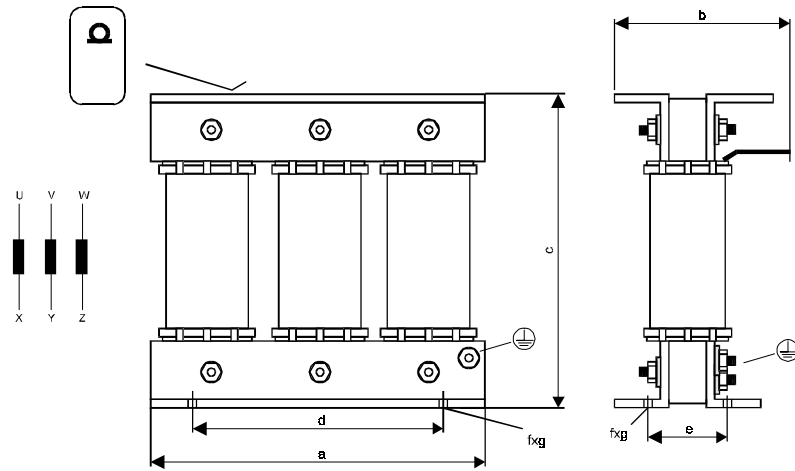

Dimensional drawing and diagram of connections A2

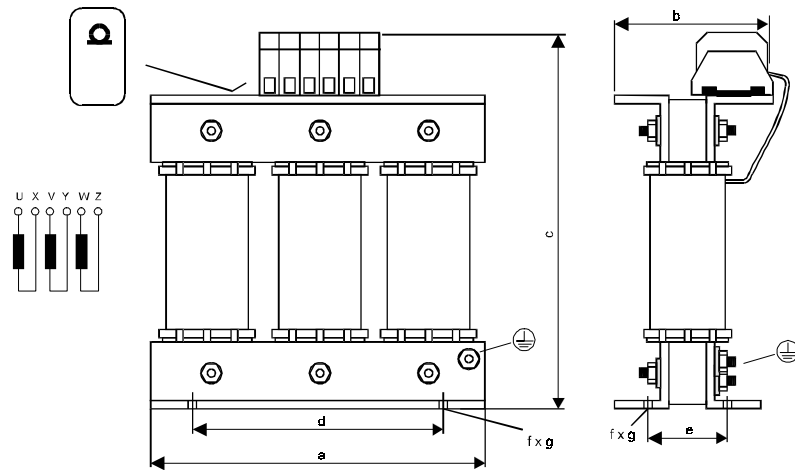

Dimensional drawing and diagram of connections A3

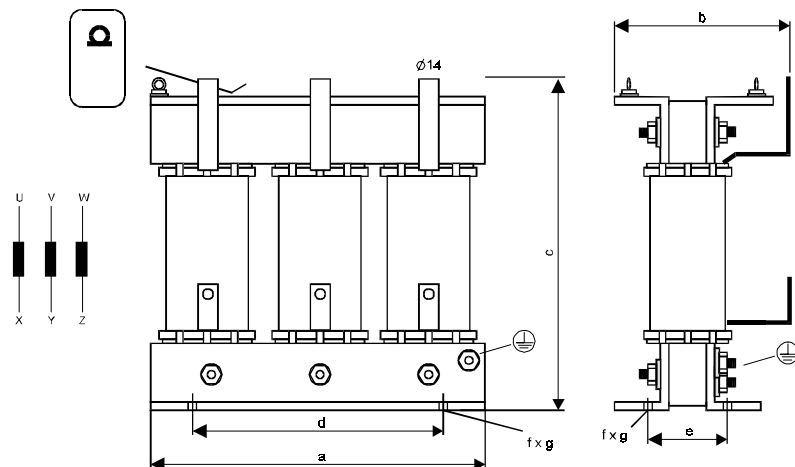

- Single-phase line commutator for 400 V or 500 V connection voltage
 $U_N = 230 \text{ V } 50/60 \text{ Hz}$, $U_K = 3 \%$, $T_A = 55 \text{ }^\circ\text{C}$, IP00, one commutator per incoming line

Commutator DR1-23-3	Rated DC Current A	a	b	c	d	e	f x g	Weight kg	Losses W	Internal Identifier 1900 ..
		mm	mm	mm	mm	mm	mm			
0003	3	56	47	72	44	34.5	7 x 3.5	0.4	6	- 7460
0008	8	67	55	81	55	41	6 x 4.5	0.75	8	- 7461
0015	15	85	64	97	64	49	9 x 4.8	1.65		- 7462
0025	25	96	80	112	84	64	11 x 5.8	2.3		- 7463

Dimensional Drawing for Field Line Commutators

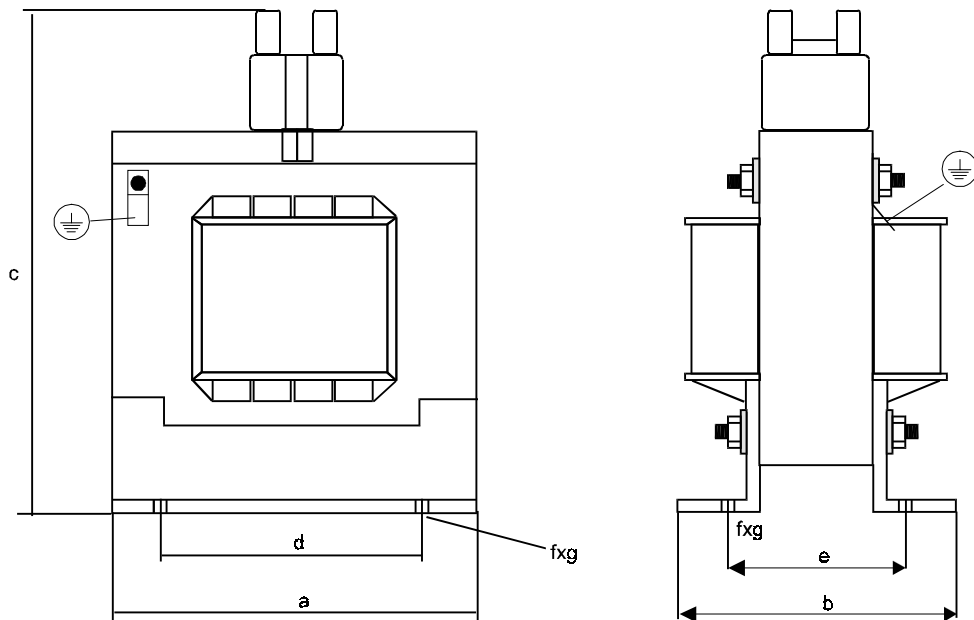

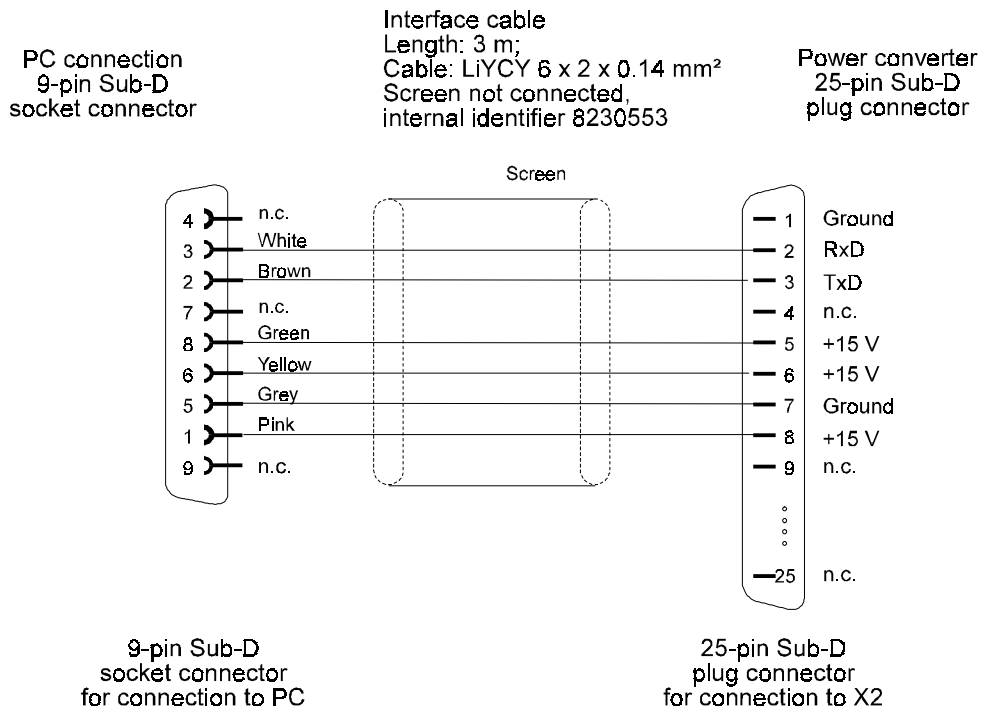

2) Operation Software

A floppy disk is available containing the software necessary for operating the equipment using a PC. On your order, please state the power converter's software version, which is shown on the two EPROMs at ports D501 and D502 on microprocessor PCB 3.8942 (state S04.xx).

6 FUNCTIONS

6.1 Function Plans

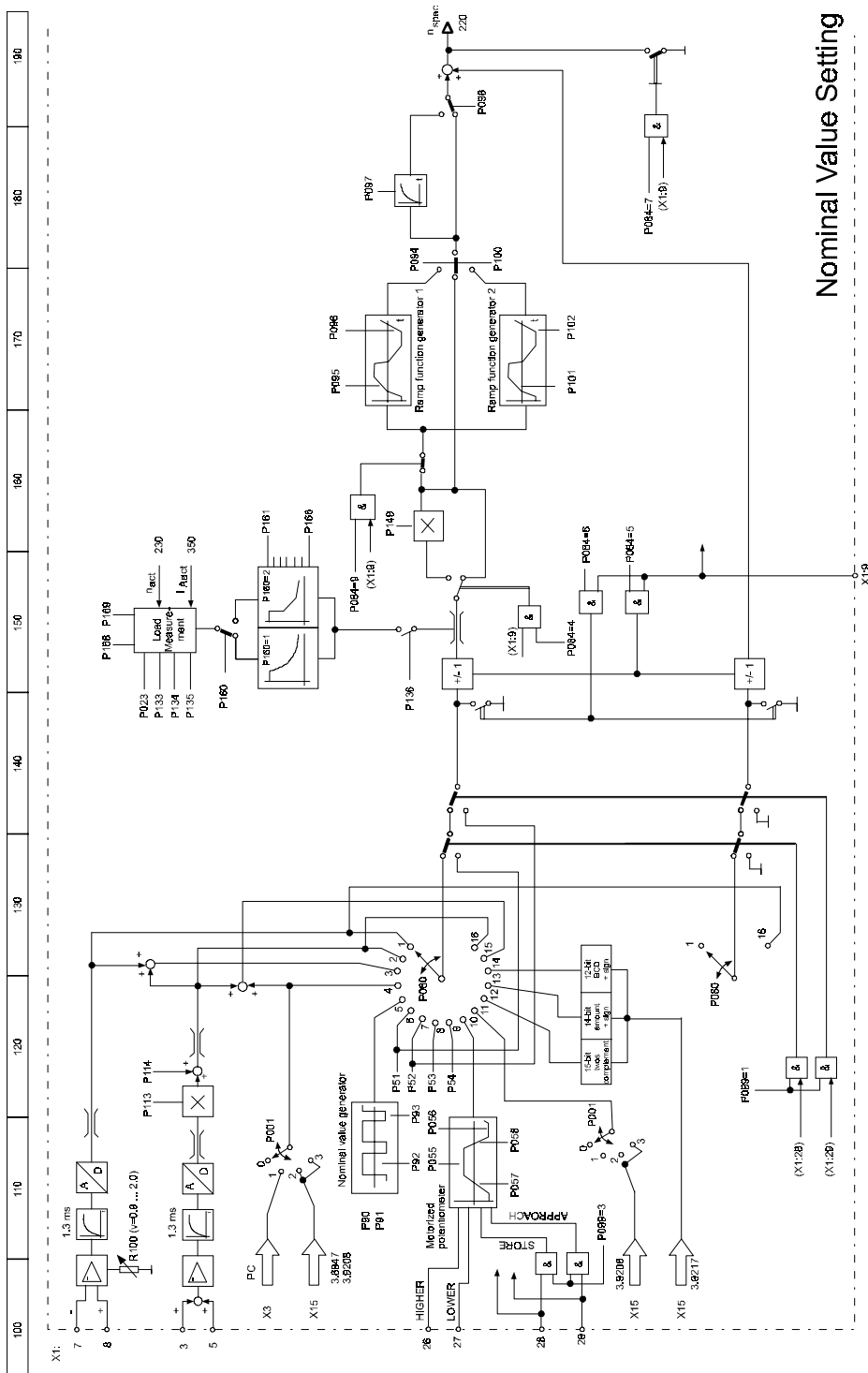

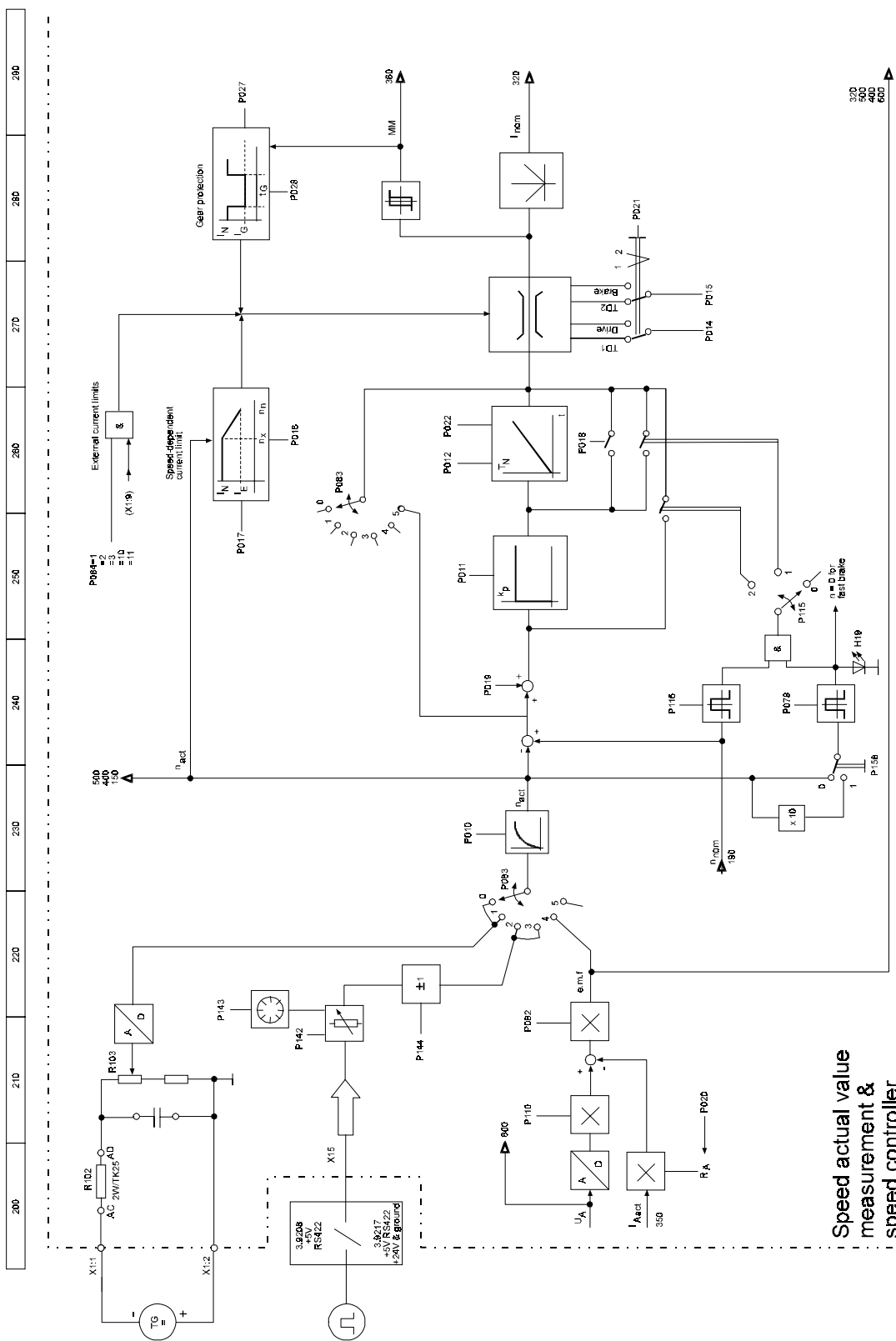

Speed actual value measurement & speed controller

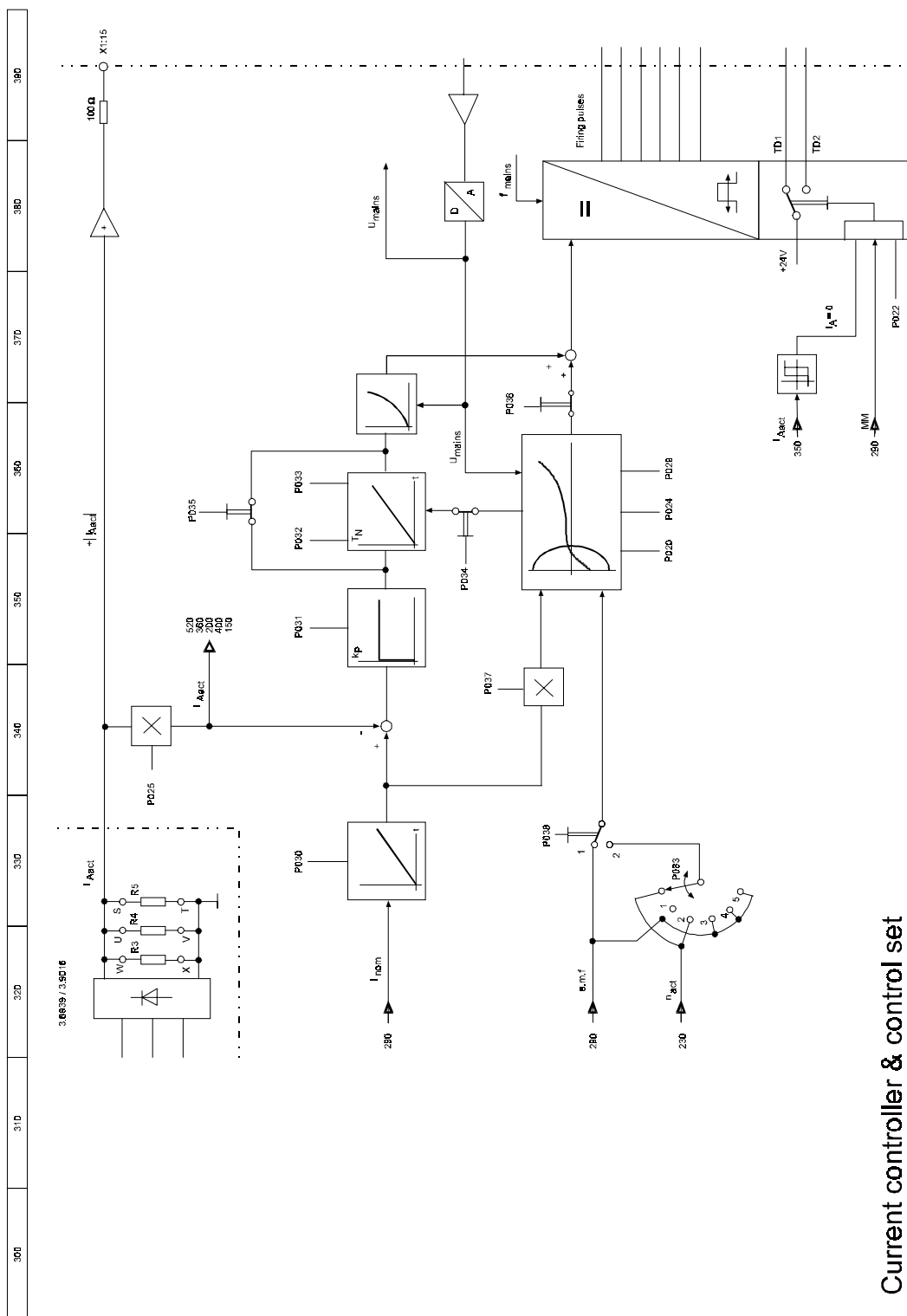

Current controller & control set

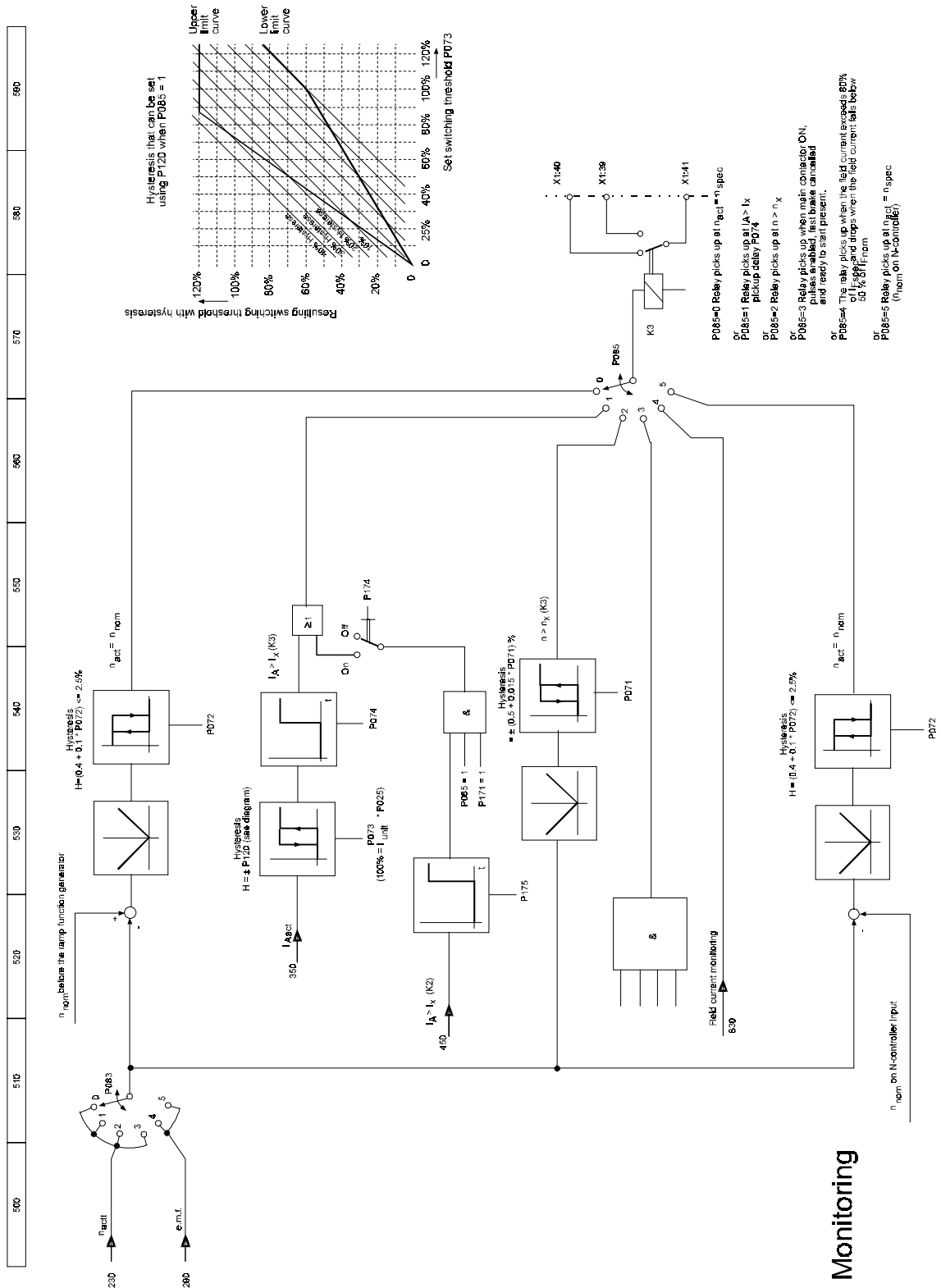

6.2 Specifying the Controller Structure

Parameter: P083=0 ... 5

Value	Meaning
0	Speed control using analog tachometer and constant field Speed matching using R103
1	Speed control using analog tachometer and field weakening Speed matching using R103
2 (S04.09 and above)	Speed control using actual value incremental encoder and constant field (see also P142 to P144)
3 (S04.09 and above)	Speed control using actual value incremental encoder and field weakening (see also P142 to P144)
4	e.m.f. control using constant field
5	Current control using constant field

- **Speed control using analog tachometer**

P083 = 0, 1

Tachometer adaptation is carried out in two places:

- Coarse adaptation using R102
Calculate the maximum tachometer voltage, U_{TG} and select a resistance value from the table below.
- If there are several options, always use the lower value:

R102	6.8k	10k	15k	22k	27k	33k
Tachometer voltage	25 V..	40 V..	60 V..	80 V..	100 V..	120 V..
U_T at n_{max}	.. 50 V	.. 80 V	.. 110 V	.. 150 V	.. 200 V	.. 230 V

- Carry out fine adaptation at commissioning using potentiometer R103

Actual value smoothing:

- Hardware: C17 (on LSP [solder bridge] AE - AF)
Default value: 0.47 μ F
- Software: P010
Default value: 10 ms

Positions of R102, R103 and C17 on PCB 3.8934:

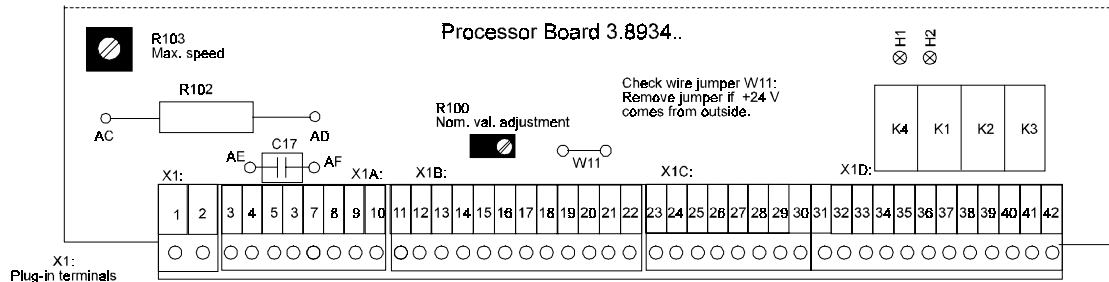

With P083 = 1 additionally

P042: Set release/armature nominal voltage

P047: Specify minimum field current

$$I_{Fmin}/I_{Fmax} \times 0.80$$

P145: Field weakening mode

0: Armature voltage

1: e.m.f.

When operating the motor in the field weakening range, the power converter carries out closed-loop control to the constant armature voltage if P145 is set to 0.

This means that the controller corresponds to the familiar conditions of analog controllers BKF 12../2000 and BKF 12../3000.

If P145 = 1, the controller carries out closed-loop control to the constant motor e.m.f. (e.m.f. = $U_{armature} \pm I_A \times R_A$; negative when driving, positive when braking).

We recommend: P145 = 1

• **Speed control using actual value incremental encoder**

P083 = 2, 3

Conditions:

- InterBus-S interface board, 3.9208 version 02 with encoder evaluation, suitable for encoders with two 90° phase-shifted differential impulses and 5-V supply from the power converter
- or
- Input/output expansion daughterboard, 3.9217
- Suitable for encoders with two 90° phase-shifted differential impulses and 5-V supply from the power converter as well as for encoders with two 90° phase-shifted differential impulses with separate 24-V supplies
- or
- Daughterboard RS484 with USS protocol or as a CS31 system bus interface, 3.9493, versions 02 and 04 with encoder evaluation.
- Power converter software version S04.09 and higher

Parameters

- P142: Nominal speed with incremental encoder
 Range: 500 RPM ... 6000 RPM S04.09 and above
 100 RPM ... 6000 RPM S04.11 and above

- P143: Number of graduations of incremental encoder

Range: 250 ... 4096

Achievable maximum speed in dependence on number of encoder graduations:

$$n_{\max} = \frac{60 \cdot 100}{P143} \text{ [RPM]} \quad \text{S04.09 and above}$$

$$n_{\max} = \frac{60 \cdot 300}{P143} \text{ [RPM]} \quad \text{S04.25 and above}$$

- P144: Polarity reversal of incremental encoder

This is needed if the directions of rotation of the motor and the encoder are different, due to the way in which the incremental encoder is mounted.

Actual value smoothing P010
 Default value: 10 ms

With P083 = 3 additionally

- P042: Set release armature nominal voltage
- P047: Minimum field current
 Specify $I_{Fmin}/I_{Fmax} \times 0.80$
- P145: See previous page

- **e.m.f. control with constant field**

P083 = 4 (default setting)

Speed adaptation using

- P082: Armature voltage matching
 Range: 0.90 ... 1.10
- P110: Armature/mains voltage
 Range: 0.50 ... 1.21

Actual value smoothing P010
 Default value: 10 ms

- **Current control with constant field**

P083 = 5

6.3 Nominal Value Assignment

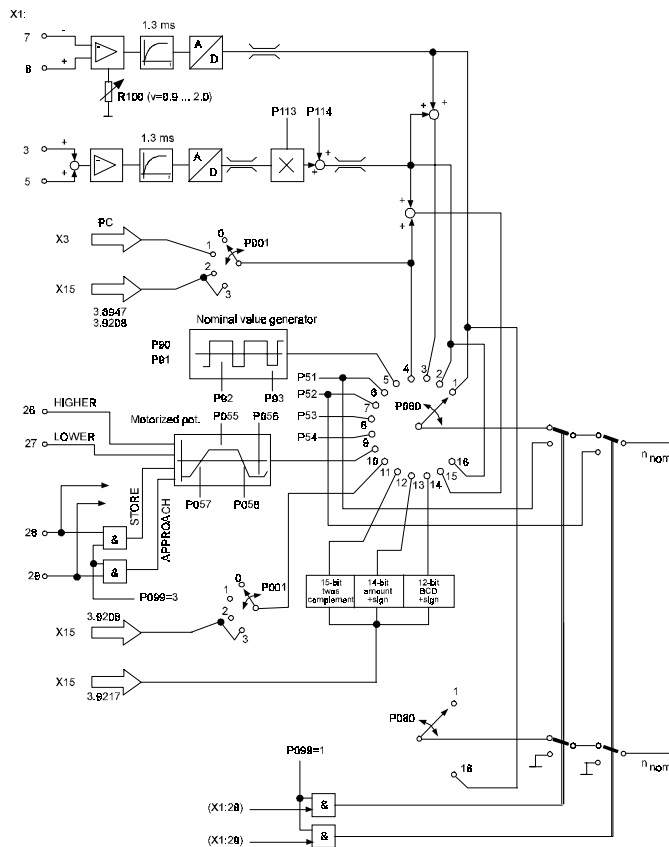

- Nominal value source

Parameter: P080 = 0...16

You can assign the speed in an analog or digital fashion (serial or parallel) as well as in the form of the total of the analog and serial digital values.

If you use nominal value sources 12, 13 and 14, note that the system does not accept a new value until it has been pending in a stable fashion at the input for at least four controller cycles (approximately 15 ms).

Internally, the maximum nominal values are limited to the specified format.

You can use parameter P050 to show the current speed nominal value on the power converter's display. With values greater than 100%, the display flashes and indicates that the software limit at the nominal value input is active.

- P080 = 1 Analog nominal value
Differential amplifier input with nominal value adaptation by means of potentiometer R100 in the range 0.9 ... 2.0 of the set specified voltage value. Terminal X1:7 has an inverting effect, terminal X1:8 has a non-inverting one. Nominal value adaptation is set at the factory to a gain of 1. With different specified voltage values, you must adjust R100 such that when setting the maximum specified voltage value (with the drive disabled!), display parameter P050 = 100% is indicated.
- P080 = 2 Analog nominal value
Non-inverting summing amplifier with nominal value adaptation by means of potentiometer P113 in the range 0.00 ... 2.00 and offset setting (P114) in the range -100%...+100%. Terminal for nominal value 1 at X1:3 and nominal value 2 at X1:5; reference voltage BSA at X1:4,6.
- P080 = 3 Analog nominal value
Formed from the nominal values at the differential amplifier (nominal value source 1) and at the summing amplifier (nominal value source 2), the software limits the resulting nominal value to +100% or -100%, the scaling and the offset are the same as before (R100, P113, P114).
- P080 = 4 Serial nominal value setting
Setting the nominal value using a PC or a controller (an interface board, such as the 3.8947 or 3.9208, is necessary). Using parameter P050, you can set serial nominal values in the range -100%...+100%. With PC setting, the resolution is 0.1%. After a controller inhibit and a subsequent controller enable, you must reenter the serial nominal value.
- P080 = 5 Nominal value generator

P090: Int. nominal value generator for nominal value 1	range -100%...+100%
P091: Int. nominal value generator for nominal value 2	range -100%...+100%
P092: Time for nominal value 1	range 0.1 s ...100.0 s
P093: Time for nominal value 2	range 0.1 s ...100.0 s
- P080 = 6 Internal nominal value 1
Can be set via P051 in the range -100%...+100%; the set value of P051 can be used for inching (print machine option) by programming switching input X1:28 (P099=1). The inching function means that the system switches to internal nominal value 1, regardless of the programmed nominal value source. At switchover, the system automatically switches in ramp function generator 1 to prevent nominal value step-changes. On cancelling the inching function, the original nominal value comes into effect again.

- P080 = 7 Internal nominal value 2
Can be set via P052 in the range -100%...+100%; the set value of P052 can be used for inching by programming switching input X1:29 (P099=1). The inching function means that the system switches to internal nominal value 2, regardless of the programmed nominal value source. At switchover, the system automatically switches in ramp function generator 2 to prevent nominal value step-changes. On cancelling the inching function, the original nominal value comes into effect again.
- P080 = 8 Internal nominal value 3
Can be set via parameter P053 in the range -100%...+100%
- P080 = 9 Internal nominal value 4
Can be set via parameter P054 in the range -100%...+100%
- P080 = 10 Motorized potentiometer function
Refer to 6.7.2 Additional Switching and Control Inputs, motorized potentiometer function
- P080 = 11 Nominal value setting using dual-port RAM, 16-bit no protocol.
Can be used in conjunction with InterBus-S daughterboard, 3.9208 only.
- P080 = 12 Parallel nominal value setting
Can be used with daughterboard 3.9217 only.
Value: 15-bit twos complement
Permissible value range: \$ 3FF0 to \$ 4010 (where \$ is the prefix for hexadecimal numbers)
- P080 = 13 Parallel nominal value setting
Can be used with daughterboard 3.9217 only.
Value: 14-bit and sign
Permissible value range: \$ 0 to \$ 3FF0 (where \$ is the prefix for hexadecimal numbers)
If bit no. 15 = 1, the system interprets the value as a negative number (amount + sign)
- P080 = 14 Parallel nominal value setting
Can be used with daughterboard 3.9137 only.
Value: 12-bit and sign. Decimal nominal value setting (amount + sign)
Permissible value range: 0 to 999 (percentual setting, 0.0 ... 99.9%).
If bit no. 15 = 1, the system interprets the value as a negative number.
If you set a code in one of the three places that is not a decimal number, the system does not accept the nominal value.
- P080 = 15 Total of nominal value sources 2 and 4
- P080 = 16 Analog nominal value
Formed from the nominal values at the differential amplifier (nominal value source 1) and at the summing amplifier (nominal value source 2), the scaling and the offset are the same as before.
Difference from nominal value source 3: The system feeds the nominal value from the differential amplifier directly to the speed controller and the nominal value from the summing amplifier is applied via the ramp function generator to the speed encoder.
Parameter P149 has no effect on this nominal value source!

- Inching see above under P080 = 6,7

See P051, P052: Internal nominal values 1, 2

See 6.7.2.: Additional switching and control inputs: programmable switching inputs X1:28 and X1:29, parameter P099 = 1

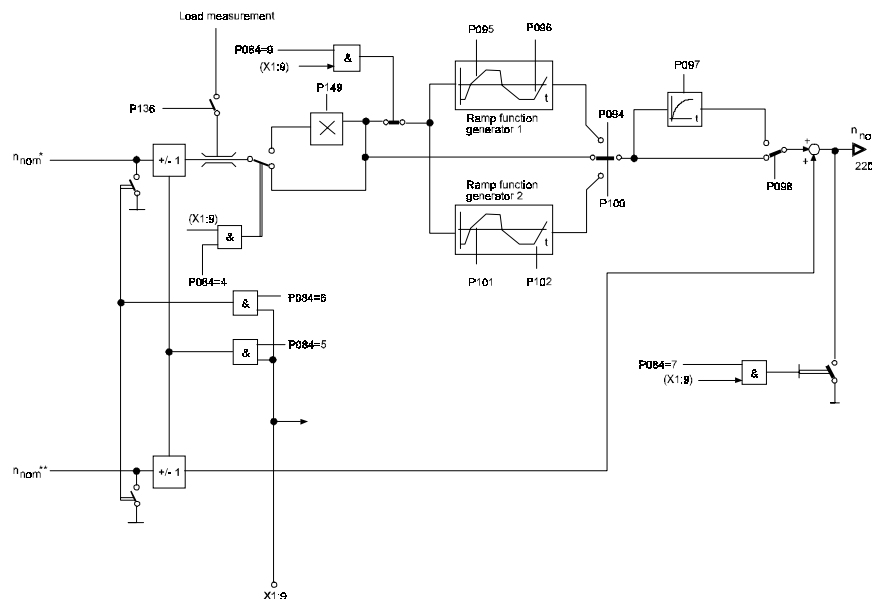

- Nominal value multiplication

There are two options:

- Multiplication of the analog nominal values at the non-inverting amplifier input (terminal X1:3,5) with nominal value source P080 = 2, 3 and 15, 16 by the value of parameter P113: 0.00 ... 2.00
- Multiplication of the nominal value pending at the ramp function generator input by the parameter value of P149 if P084 (programmable input) = 4 and a low signal is applied to terminal X1:9 (see the diagram above).

This function works with nominal value sources P080 = 1...15, but not with P080 = 16!

Parameter P149 "nominal value multiplier" has a value range of 0.00 ... 1.00, see 6.7.2:

Additional switching and control inputs, Programmable input X1:9: P084 = 4

- Reverse direction of rotation

With P084 = 5, the system inverts the polarity of the nominal value at the ramp function generator input if a low signal is applied to terminal X1:9. See 6.7.2: Additional switching and control inputs, Programmable input X1:9: P084 = 5

- Nominal value zeroing

With P084 = 6 or 7, the system sets the speed nominal value to $n = 0$ if a high signal is applied to terminal X1:9.

Two variants are available:

- P084 = 6 sets the nominal value at the ramp function generator input to 0. As a result, the ramp function generator's shutdown ramp remains active and the drive is synchronously decelerated.
- With P084 = 7, the ramp function generator output is set to 0. In this case, the drive is shut-down at the unit current limit.

In both cases, when the nominal value zeroing command is cancelled, the system approaches the original nominal value via the acceleration ramp set on the ramp function generator. See 6.7.2: Additional switching and control inputs, Programmable input X1:9 : P084 =6, 7

- Ramp function generator

Two ramp function generators are available:

- Ramp function generator 1:

P094: "Ramp function generator 1":	Range: On/Off
P095: "Ramp function generator 1" Acceleration time:	Range: 0.0 ... 850.0 s
P096: "Ramp function generator 1" Deceleration time:	Range: 0.0 ... 850.0 s
- Ramp function generator 2

P100: "Ramp function generator 2":	Range: On/Off
P101: "Ramp function generator 2" Acceleration time:	Range: 0.0 ... 850.0 s
P102: "Ramp function generator 2" Deceleration time:	Range: 0.0 ... 850.0 s

NOTE:

When you select the Inching function, the system automatically switches to ramp function generator 2.

- Ramp function generator stop

With P084 = 9 and a high signal at X1:9, the ramp function generator's output is kept at the current value.

- S-ramp generator

With the S-ramp generator activated, the system additionally routes the nominal value via a first-order time-delay element that is located before the speed controller. This first-order time-delay element ensures a smooth speed curve at the drive.

The S-ramp generator makes it possible to smooth the hook in the characteristic curve at the end of the ramp function generator's acceleration and deceleration ramp, thus preventing any torque surges and oscillations that may occur.

- | | |
|---|----------------------------|
| P098: "S-ramp generator" | Range: On/Off |
| P097: "Time constant of S-ramp generator" | Range: 0.01 sec...6.50 sec |

Setting note: Time constant P097 is usually set to a maximum of 20% of the acceleration and deceleration time at the ramp function generator (P095/P096 or P101/P102).

6.4 Current Limits

6.4.1 Current Limits for the Armature

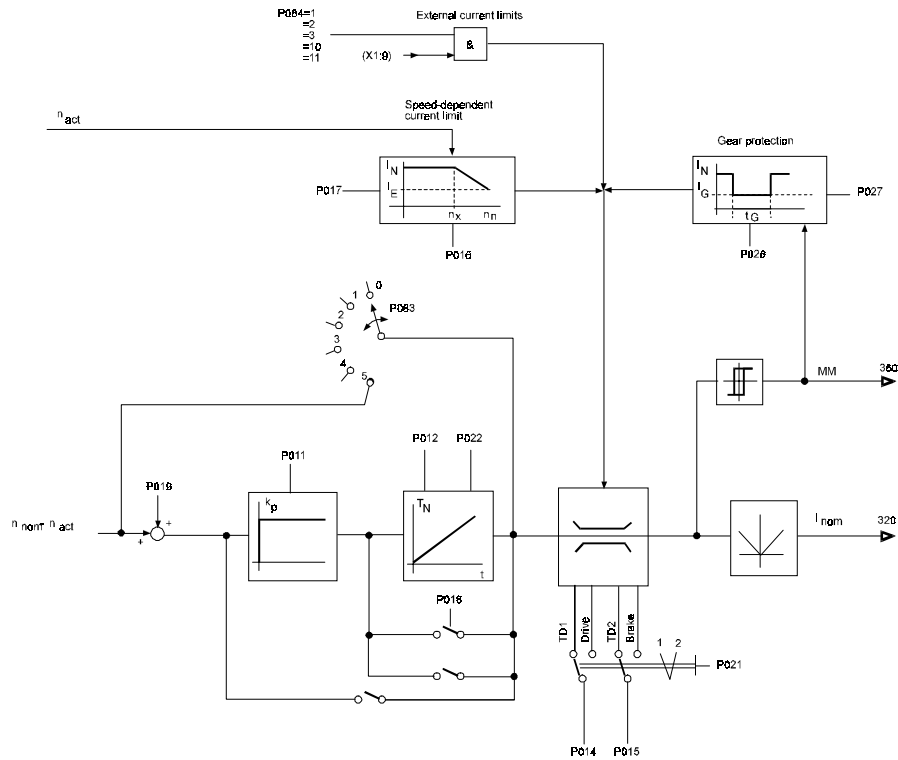

Internal current limits

- Armature current adaptation P025
Setting the maximum unit output current

$$P025 = \frac{\text{Max. permissible armature current of motor}^1}{\text{Unit's rated current}^2}$$

1. Maximum permissible armature current or rated motor current (S1, S3, S6 operation) according to motor rating plate
2. Rated current according to unit rating plate or display parameter P000

The armature current set with P025 is shown in display parameter P062, "actual value of armature current" as 100%.

- Additional current limits for both torque directions and driving and braking

P014: Current limit for torque direction 1 Range: 0%...100%
 P015: Current limit for torque direction 2 Range: 0%...100%
 P021: Current limit switchover Range: 1...2

Value	Meaning
1	P014 = Current limit for torque direction 1 P015 = Current limit for torque direction 2
2	P014 = Current limit for driving P015 = Current limit for braking

- Speed-dependent current limiting

This limit is needed with motors that are run in the overload range at the black band. Refer to the motor's rating plate for the power converter setting values.

P016: n_x , start of speed-dependent current limit Range: 0%...100% of n_{nom}
 P017: I_{end} , end of speed-dependent current limit Range: 0%...100% of I_{Anom}

- Gear protection

Limiting the armature voltage on changing the torque direction for a selectable time period. May be needed to protect some of the drive's mechanical components, e.g. the gears.

P027: Gear protection current Range: 0% ... 100% of I_{Anom}
 P028: Gear protection time Range: 0 ms ... 500 ms

The time for which the current limit set using P027 is to be in effect following a change of torque direction.

External Current Limitation

Parameterization: P084 = 1, 2, 3, 10, 11
 Programmable input X1:9 as an analog input

P084: possible current limitation modes:

- a) 0 ... +10 V corresponds to 0 ... 100% current limit
 < 0 V corresponds to 0% current limit

Value	Meaning
0	No function, input deactivated
1	Current limit for torque direction 1 0 V to +10 V corresponds to 0 to 100% current limit < 0 V corresponds to 0% current limit
2	Current limit for torque direction 2 (same setting as 1)
3	Current limits for torque directions 1 and 2 (variable)

- b)

10 (S04.21 and above)	0 V to + 10 V corresponds to 0 to 100% external current limit for torque direction 1 and to 0% for torque direction 2 0 V to -10 V corresponds to 0 to 100% external current limit for torque direction 2 and to 0% for torque direction 1
11 (S04.21 and above)	0 V to + 10 V corresponds to 0 to 100% external current limit for torque direction 2 and to 0% for torque direction 1 0 V to -10 V corresponds to 0 to 100% external current limit for torque direction 1 and to 0% for torque direction 2

6.4.2 Current Limitation at the Field Current Converter

- Field current adaptation P049

$$P049 = \frac{\text{Motor field current}}{\text{Field unit rated current}}$$

The field current that you set using P049 is shown in parameter P064, "Actual value of field current" as 100%.

- Minimum field current P047

This is only needed in the case of controller structures with field weakening control: P083 = 1, 3

$$P047 = 80\% \times \frac{\text{Min. motor field current}}{\text{Max. motor rated current}}$$

The factor 80% is needed so that at the maximum speed there is still enough controller reserve available. Ignoring this may lead to the armature voltage assuming impermissibly high values.

6.5 Monitoring

The relay contacts can be loaded with a maximum of 24 V/1 A, and a minimum of 1 V/1 mA. The maximum potential to electronic ground that is allowed is 50 V.

6.5.1 Ready for Use Relay K1

Relay K1 picks up in the ready for use condition. If there is an operational disturbance, the relay drops for at least one second. In the case of an operational disturbance, relay K1 "Main contactor ON" on PCB 3.8942 also drops and, with this, deenergizes the power unit.

NOTE

In this unit, two relays are designated as K1!

Relay K1 "Main contactor ON" is on field controller board 3.8942, (X2:3,4,5).

Relay K1 "Ready for use" is on CPU board 3.8934 (X1:33,34,35).

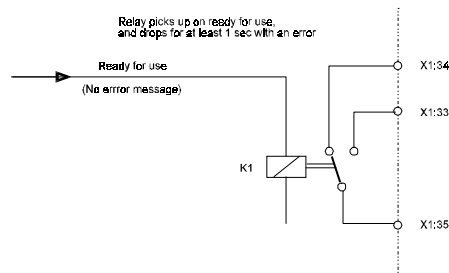

Relay K1 on the CPU board drops in the case of all error messages numbered 01 to 99. In addition, activation of the relay leads to an internal controller inhibit (the drive is instantaneously torque-free). Error numbers above 100 are messages that do not interrupt ongoing operation. The system merely displays them and they do not lead to a controller inhibit or to operational disturbance K1. For a description of errors, refer to chapter 9.3, List of Errors.

6.5.2 Relay K2

Parameterize using P171: "Relay output K2"

Value	Meaning
0	$n > n_x$ message. The switching threshold is specified using P070.
1	$I_A \geq I_x$ message. The switching threshold is specified using parameter P172 and refers to the maximum equipment output current (P025).

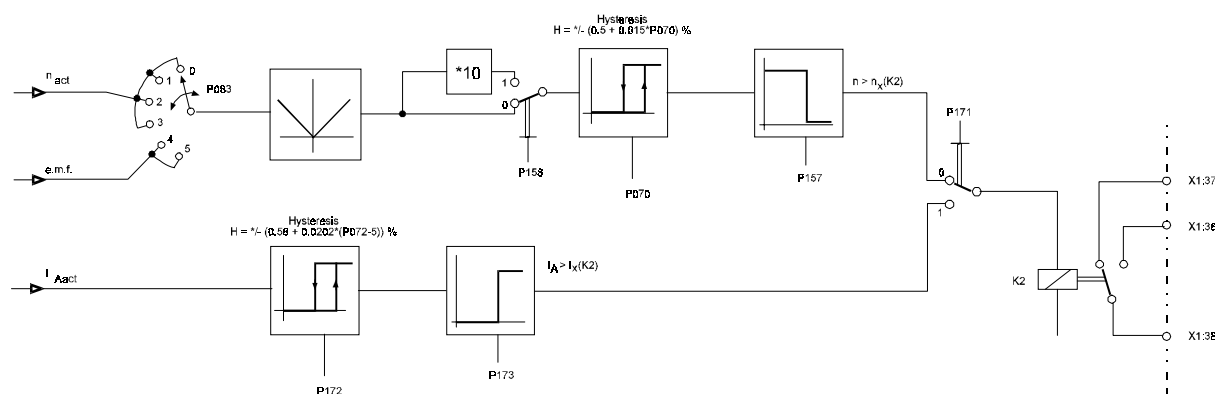

- Speed monitoring via relay K2

Programming of relay K2
 Switching threshold $n > n_x$
 Multiplier for P070

Shutdown delay of K2/0
 Hysteresis

P171 = 0
 P070 = ... % of the maximum speed
 P158 = 0: P070 = 1 ... 105% of n_{nom}
 P158 = 1: P070 = 0.1 ... 10.5% of n_{nom}
 P157 = 0.00 ... 30.00 s
 $H = \pm (0.5 + 0.015 * P070)$ in % of n_{nom}
 Contact X1:36 - 38 is closed at $n > n_x$

- Armature current monitoring via relay K2

Programming of relay K2
 Switching threshold $I_A > I_x$
 Response time $I_A > I_x$
 Release time
 Hysteresis

P171 = 1
 P172 = 5 ... 120% of P025
 P173 = 0.0 ... 30.0 s
 100 ms constant
 $H = \pm (0.58 + 0.0202 * (P072-5))$ in % of I_{Anom}
 Contact X1:36 - 38 is closed at $I_A > I_x$

- Operating speed reached Message ($n_{set} = n_{act}$) using relay K3, optionally:

- n_{set} before the ramp function generator P085 = 0
- n_{set} after the ramp function generator P085 = 5

Switching threshold $n_{set} = n_{act}$

P072 = 1 ... 60% of n_{nom}

Hysteresis

$H = \pm (0.4 + 0.1 * P072) \leq 2.5\%$ of n_{nom}

Contact X1:39 - 41 is closed (relay picked up) at $n_{nom} = n_{act}$

- Armature current monitoring via relay K3

Programming of relay K3

P085 = 1

Switching threshold $I_A > I_x$

P073 = 5 ... 120% of P025

Response time $I_A > I_x$

P074 = 0.0 ... 30.0 s

Release time

100 ms constant

Hysteresis

P120 = ± 1 ... 40% of P025

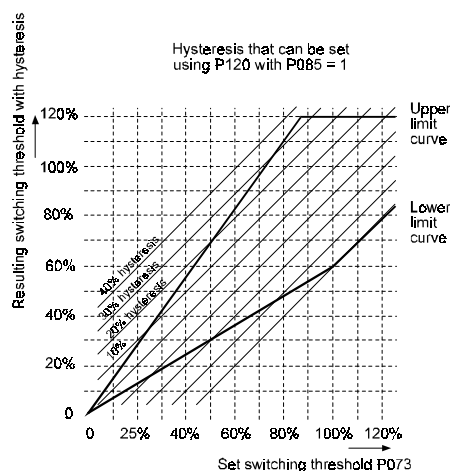

$I_A > I_x$.

- Speed monitoring via relay K3

Programming of relay K3

P085 = 2

Switching threshold $n > n_x$

P071 = 1 ... 105% of n_{nom}

Hysteresis

$H = \pm (0.5 + 0.015 * P071)$ in % of n_{nom}

Contact X1:39 - 41 is closed (relay picked up) at $n > n_x$

- Drive ready to start message via relay K3

Programming of relay K3

P085 = 3

Drive ready to start means that

main contactor is ON
pulse enable, cancellation of fast brake and unit ready to start have been given

Contact X1:39 - 41 is closed, i.e. relay picks up as soon as the following enables are pending:

on the PC
and then on the unit:

F8 and F9 to ON (P001 = 1, 2 or 3)
pulse enable: X1:25
fast brake: X1:24
main contactor ON X1:22

Relay drops (contact X1:40 - 41 is closed) when:

on the PC
or:

F8 or F9 are OFF
in the case of fast braking or main contactor OFF

or:

in the case of an operational disturbance

The relay does not drop when the controller enable is removed.

- Field current monitoring using relay K3

Programming of relay K3

P085 = 4

Contact X1:39 - 41 is closed (relay K3 picked-up) if the field current is $> 80\% I_{Fset}$. K3 drops at a field current of $< 50\% I_{Fset}$.

You cannot change the switching threshold. The function is independent of all the enables.

6.5.4 Linking the Armature Current Monitoring Relays of K2 and K3

Parameter P174:

Value	Meaning
ON	This is only effective if relays K2 and K3 are assigned with the function $I_A \geq I_x$ (P085 = 1 and P171 = 1).
OFF	K2 and K3 switch independently of one another. This means that two separate current monitoring relays are available.

Relay K2 picks up if the armature current exceeds the threshold you set with P172 and the timeout set with P173 is exceeded. If the armature current now no longer exceeds the threshold you set with P172, relay K3 also picks up after the timeout you set with P175 even if the armature voltage does not reach the threshold set for K3 (P073).

Condition: You must set the switching threshold for K2 (P172) lower than that for K3 (P073).

Setting:

Linking relay K2/1 to K3/1

P174 = ON

Linking the functions

P175 = 0 ... 900 s

Switching threshold $I_A > I_x$ for K2

P172 = 5 ... 120% of P025

Switching threshold $I_A > I_x$ for K3

P073 = 5 ... 120% of P025

6.5.5 Relay K4

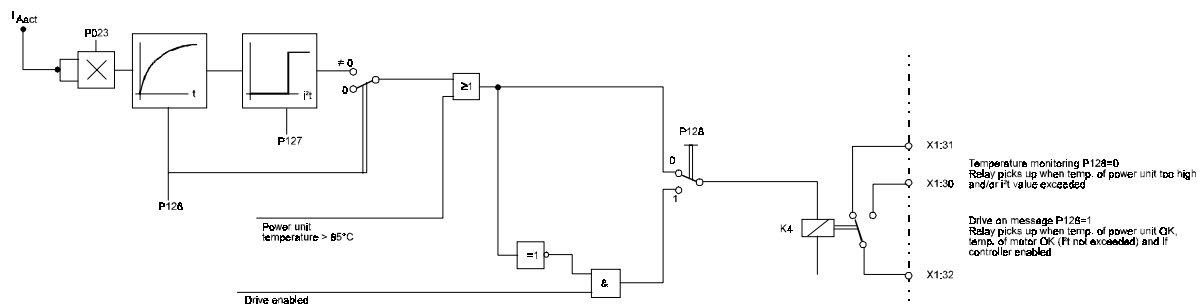

Parameterize using parameter P128: "Relay output K4"

Value	Meaning
0	Temperature monitoring
1	Drive ON

- Temperature monitoring using relay K4 P128 = 0

Contact X1:30 - 32 is closed (K4 picked-up) if the temperature of the power unit is too high or the motor's I^2t value is exceeded.

The temperature of the power unit is shown by parameter P063, with parameter P069 showing the motor's I^2t value. This value allows you to draw conclusions about the temperature of the motor.

Contact X1:31 - 32 is closed (K4 has dropped) if the temperature of the power unit is below the release threshold of 85 °C and the motor's I^2t is fallen below.
- Drive ON message with relay K4

Contact X1:30 - 32 is closed (K4 picked-up) if the temperature of the power unit is OK, the I^2t value has not been reached and the controller is enabled.

Contact X1:31 - 32 is closed if either the temperature of the power unit is too high, the motor's I^2t value is exceeded, or the controller is not enabled.
- Setting the I^2t monitoring relay (P126 and P127)

The I^2t value is calculated from the armature current and the time, starting from the time of switch-on. The system displays the value via P069 and reports via relay K4 the instant when the preset value of P127 is exceeded.

As an alternative, it is also possible to externally analyze the I^2t by means of one of the measuring channels (P088 or P089 = 37).

The parameters below must be determined from the motor and operating data:

- Armature current, controlled $P025 = 0.5 \dots 1.0$
- $P025 = \frac{\text{Max. motor current in A}}{\text{Rated unit current in A}}$
- Motor's therm. time constant τ $P126 = 0 \dots 180 \text{ min}$
- Motor's overload factor $P023 = 0.5 \dots 1.0$
- $P023 = \frac{\text{Rated motor current (S1)}}{\text{Motor overload current (Sx mode)}}$
- I²t release threshold $P127 = 50 \dots 110\%$
usually set to 100%, since the temperature of the winding rises too much at 110%

Example:

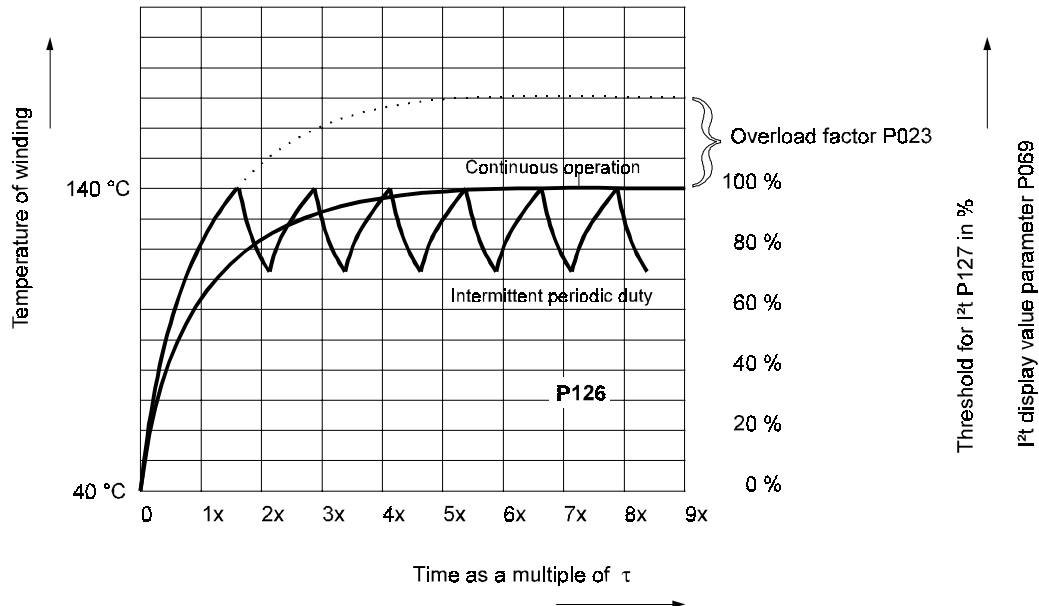

Motor temperature in continuous operation (S1) and intermittent periodic duty.

τ: Motor's thermic time constant

Determining the release time t_{rel}

- The release time t_{rel} is dependent on the motor's thermic time constant, τ_M , on the overload factor, P023, and on the release threshold P127.
- You can calculate the release time or the time constant as follows:

$$\frac{t_{rel}}{\tau_M} = -\ln \left\{ 1 - \frac{P127}{100\%} \cdot (P023)^2 \right\}$$

- Motor's overload factor: $P023 = 0.5 \dots 1.0$
- I²t release threshold $P127 = 50 \dots 110\%$

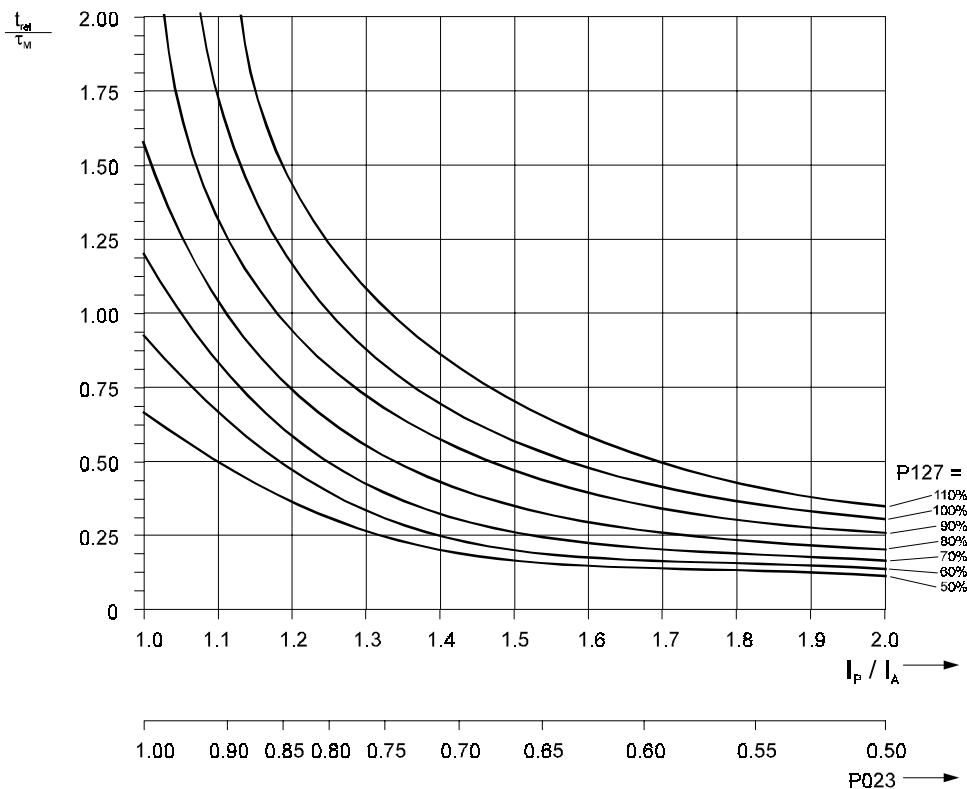

Factor t_{rel}/τ_M in dependence on the overload factor P023 and the release threshold P127

If you reset the system or switch the power supply to the electronics on or off, the calculated value is lost. The system then assumes that the motor is not under load.

6.5.6 Displaying and Checking the Relay Functions

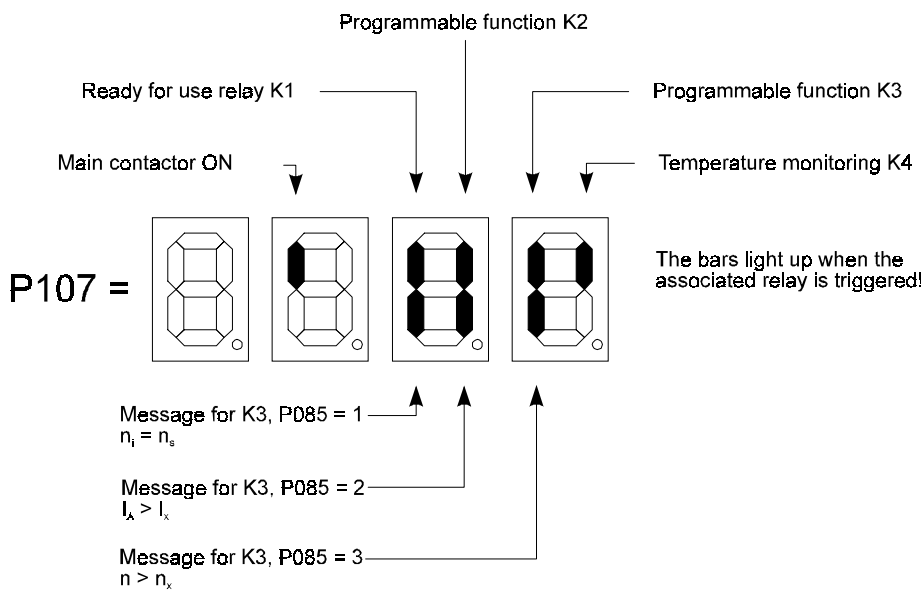

6.6 Analog Output on Measuring Channels 1 ... 4

P088: Analog output channel 1
 PCB 3.8934: X1:11, reference potential at X1:12

P089: Analog output channel 2
 PCB 3.8934: X1:13, reference potential at X1:14

Output standardized to 0 ... ± 10 V, refresh rate 3.3 ms, resolution 150 mV
 scaling of channel 2 via P125

P130: Analog output channel 3
 Option of: PCB 3.9201: X4:1, reference potential at X4:2
 or: PCB 3.9217: X7B:2, reference potential at X7B:1

P131: Analog output channel 4
 Option of: PCB 3.9201: X4:3, reference potential at X4:4
 or: PCB 3.9217: X7B:4, reference potential at X7B:3

Output standardized to 0 ... ± 10 V, refresh rate 3.3 ms, resolution 150 mV
 scaling of channel 4 via P132

Value	Meaning	Polarity	
		Pos.	Neg.
1	Speed nominal value	Pos.	Neg.
2	Ramp function generator output	Pos.	Neg.
3	Nominal value at speed controller	Pos.	Neg.
4	Speed actual value	Neg.	Pos.
5	Armature voltage	Pos.	Neg.
6	e.m.f.	Pos.	Neg.
7	Speed controller output	Pos. with torque dir. 1, neg. with torque dir. 2	
8	Amount of speed controller output	Pos.	
9	Amount of I_{act} ($ +I_{Aact} $)	Pos.	
10	Current controller output		
11	Power	Pos. with driving, neg. with braking	
12	Field current nominal value	Pos.	
13	Field current actual value	Pos.	
14	Field current controller output	Pos.	
15	Converter input		
16	Converter output		
17	Speed controller for P component		
18	Speed controller for I component		
19	Torque indicator	0 V with torque dir. 1, +5 V with torque dir. 2	

Value	Meaning	Polarity
20	ZIL (second pulse suppr.)	0 V with ZIL, otherwise +5 V
21	Pulsating limit	
22	Pulsating curve	
23	e.m.f. correction	
24	$I \times R$	Pos.
25	U_{α}	
26	Queue	
27	Current controller for P component	
28	Current controller for I component	
29	Field current controller for P component	
30	Field current controller for I component	
31	Field voltage controller for P component	
32	Field voltage controller for I component	
33	Controller inhibit/enable	0 V with inhibit, +5 V with enable
34	Current limit	Pos./neg.
35	Amount of speed actual value	Pos.
36	Armature current actual value (+/-)	Pos. with TD1, neg. with TD2
37	I^2t value	Pos.
38	Driving/Braking	Driving: +5 V, braking: 0 V
39	Polarity of n_{act}	0 V with $n_{nom} = pos$
40 (S04.05 and above)	Load torque	
41 (S04.05 and above)	Permissible n_{nom} with load measurement	
42 (S04.05 and above)	Threshold of field monitoring	
43 (S04.22 and above)	Torque indicator, inverted to 19	+5 V with torque direction 1, 0 V with torque direction 2
44 (S04.27 and above)	Current reserve $(-1) \times (I_{act} - 10 V)$ With a current actual value of 0 V (test point 9), this test point has an output voltage of +10 V; with a current actual value of +10 V, its output value is 0 V.	
45 (S04.28 and above)	$- I_{aact} $ inverted to test point 9	Neg.
46 (S04.28 and above)	Inverted to test point 36	Neg. with TD1, pos. with TD2
47 (S04.29 and above)	Mains voltage, e.g. +4.00 V corresponds to a mains voltage of 400 V _{eff}	

TD1: Torque direction 1, indicated by LED H18/green

TD2: Torque direction 2, indicated by LED H17/yellow

Definition of Four-Quadrant Operation:

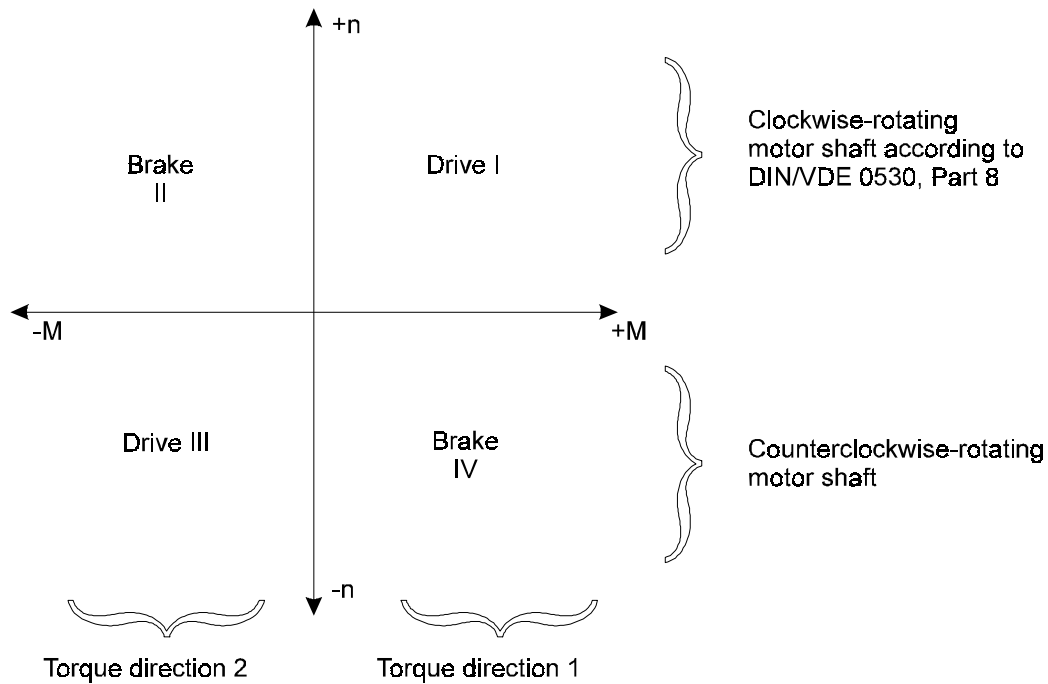

With positive speed values, LED H18/green (TD1) is lit-up, when the motor is being driven (driving torque direction 1 = operation in quadrant I). If you wire the motor and the power converter with the polarity of the armature, field and tachometer connections in accordance with the connection suggestion, the motor shaft rotates clockwise.

6.7 Controlling the Power Converter, Sequence of Switching On and Off

On terminal strip X1 on the microprocessor board, there are four switching inputs available (X1:22 ... 25) for controlling the unit.

By means of these terminals, you can enable or inhibit the controller, and bring the drive to a defined stop and switch it off.

When operating the power converter with a service PC (e.g. at commissioning) or via one of the possible interfaces, these functions are also available as software commands.

A total of five additional switching inputs are available for advanced control tasks; three of these inputs have parameterizable functions:

6.7.1 Enables on the Power Converter and Main Contactor Control

Four enable signals:

- | | | | |
|--------------------------|---|--------------------|-------|
| • Main contactor ON (HE) | / | Main contactor OFF | X1:22 |
| • Controller enable (RF) | / | Controller inhibit | X1:23 |
| • Cancel fast brake | / | Fast brake (SH) | X1:24 |
| • Pulse enable (IF) | / | Pulse inhibit | X1:25 |

The enable commands are logically ANDed:

The power converter is enabled if X1:23, 24, 25 are connected to +24 V and, in addition, a switching operation from 0 V \Rightarrow +24 V takes place at X1:22. Normally, input X1:22 is edge-triggered; during operation with a service PC or via an interface board, it can be parameterized as a static signal input.

The power converter is disabled as soon as a terminal is connected to 0 V or is open.

Signal level:	ON	+24 V (+15 V ... +30 V)
	OFF	0 V (0 V ... +5 V)

Input resistance: $R_i = 3 \text{ k}\Omega$

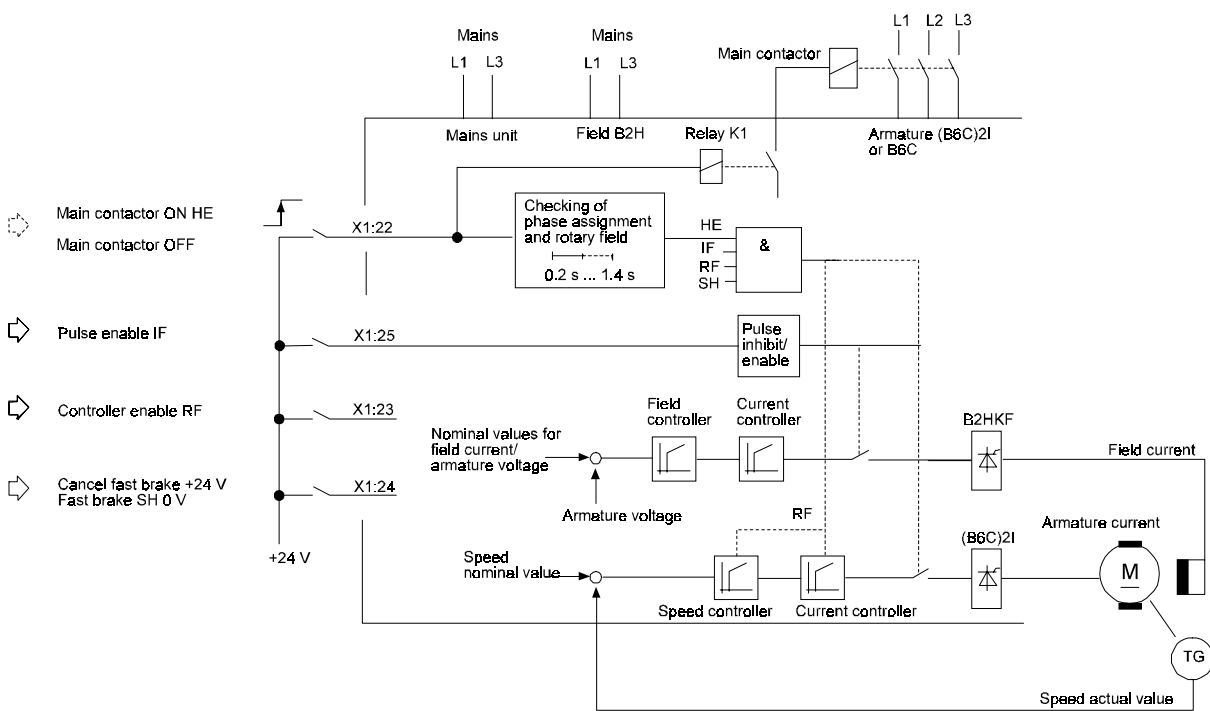

• **Controlling the Unit with Communication Source P001=0: Keypad on Power Converter**

The power converter is run in this mode if no service PC is connected and no interface boards are present to link to an external bus system.

Main contactor ON

Switching input X1:22
 Enable: Edge control 0 V ⇒ +24 V
 Disable: 0 V or open contact

Function:

Enable: Relay K1 on the PCB for field and mains unit supply 3.8942 picks up and connects the power unit to the mains via the main contactor, unless there is an error condition.
 This always takes place with P124=1, even if other enables are still missing.
 To enable the unit with P124 = 2, you must specify "Cancel fast brake" before "Main contactor ON".

P124 Main Contactor/Controller Inhibit Function

Value	Meaning
1	Fast brake Main contactor stays on, Controller inhibit at $n < n_x$ (P078) switched-off
2	Fast brake In addition, the main contactor is switched-off at $n < n_x$ (P078), at enabling, Cancel fast brake must be applied before Main contactor ON.

After Main contactor ON, the system waits approximately 70 ms at a mains frequency of 50 Hz (approximately 55 ms at 60 Hz) before checking the phase assignment of the power unit connection, the field connection and the mains unit (electronics supply). Additionally, phase failure and rotary field monitoring are active. Measuring takes approximately 130 ms at 50 Hz. Due to the different pick-up times of the contactors used for mains supply (caused by the switching capacity, etc.), the system repeats the measuring procedure (waiting and measuring times) up to seven times until an error message is generated, with the maximum delay amounting to approximately 1.4 seconds at 50 Hz. You must consider these times (minimum of 0.2 s and maximum of 1.4 s) assuming that the Main contactor ON contact was the last one to be applied in the enable sequence.

Input " Main contactor ON" is edge-triggered: this means you cannot permanently connect it to +24 V. At this input, a switching operation must **always** take place to enable the power converter.

NOTE

Unit sizes III and IV:

In the case of units up to and including software version 04.16, if you are not going to use the function of relay K1, "Main contactor ON" on the power converter on PCB 3.8942 (terminals X2: 3 ... 5), you must wait at least five seconds after switching in mains unit (X2:1, 2) before you may connect the power unit to the mains.

Disable:

The drive is switched torque-free and, once the armature current has dropped to zero, the power unit is disconnected from the mains via the mains contactor. The drive coasts to a standstill without being braked.

In this case, contacts X1:23 and X1:24 do not affect the power converter.

NOTE

After opening the Main contactor ON contact, you may not close it again until the time set with P146 plus 150 ms has elapsed so that a controller enable can be carried out. If you ignore this safety period, the power converter remains disabled!

You must also take this time into account with an armature circuit switchover (two motors alternately on one power converter).

Ignoring this results in the error message "Tachometer breakage"

Controller enable

Switching input: X1:23
 Enable: +24 V
 Inhibit: 0 V or open contact

Function:
 Enable: Undelayed enabling of the firing pulses and of the controller if the other enables are pending.
 Inhibit: Unbraked off; the drive is switched torque-free. During deceleration, the power converter can be enabled again.
 If, after opening the contact, you additionally cancel "Main contactor ON", the power converter's power unit is disconnected from the mains.

Fast brake

Switching input: X1:24
 Enable: +24 V
 Inhibit: 0 V or open contact

Function:

P123 Emergency Stop: Ramp/Max. Torque

Value	Meaning
1	Fast brake at maximum torque
2	Fast brake on the ramp (only if a ramp function generator is switched on: P094 or P100)

P124 Main Contactor/Controller Inhibit Function

Value	Meaning
1	Fast brake Main contactor stays on, controller inhibit switched-off at $n < n_x$ (P078)
2	Fast brake In addition, the main contactor is switched off at $n < n_x$ (P078), at enabling, Cancel fast brake must be applied before Main contactor ON.

a) P123=1, P124=1

Enable: "Cancel fast brake"
 Undelayed enabling of the controller if the other enables are pending.

Inhibit: "Fast brake"
 Fast brake at maximum torque up to $RPM = 0$ (P078); at $n = 0$ the controller is disabled; the main contactor stays on. The fast brake function can be interrupted: On reenabling, the system accelerates to the previous speed on the ramp function generator's ramp, assuming that the generator is switched on.

b) P123=2, P124=1

Enable: Undelayed enabling of the controller if the other enables are pending.

Inhibit: Fast brake via the ramp function generator's ramp up to RPM = 0 (P078); at n = 0 the controller is disabled, the main contactor stays on.
The fast brake function can be interrupted.

c) P124=2

Enable: For starting, "Cancel fast brake" must be applied first, then Main contactor ON by means of an L ⇒ H edge change.

Inhibit: Option of fast brake at maximum torque or via the nominal value integrator's ramp (P123=1 or 2) up to RPM = 0, at n = 0 there is an internal controller inhibit and the main contactor drops via K1 on PCB 3.8942. This procedure cannot be interrupted.

Reclosure: Cancel fast brake, switch main contactor OFF and then ON again by means of an L ⇒ H edge change.

Pulse inhibit – For emergency use only –

Switching input: X1:25

Enable: +24 V

Inhibit: 0 V or open contact

Enable: Undelayed enabling of the firing pulses and of the controller if the other enables are pending.

Inhibit: Regardless of the operating status, the system switches off the pulses for triggering the power units of the armature and the field after 3 ms. Pulse enable/inhibit are completely hardware functions that intervene directly in the output stage (pulse generation). Pulse enable can lead to the fuse dropping. In a worst case situation, the thyristors can be damaged (inverter tilting)! You should therefore use this function as a high-level switch-off facility only.

• **Controlling the Unit Using Communication Source P001 = 1, 2 or 3:**

- Service PC
- Control via interface board
- Control via interface board and keyboard

The hardware enables at control inputs X1:22 ... 24 are logically ANDed with the serial enables via PC or controller.

Pulse disable is routed directly to the control block and cannot be serially influenced.

While PC enables are pending, you can only operate the power converter by means of the hardware contacts.

- * **Controller enable**
Contact X1:23 and F7 key on the PC
In the case of an operational disturbance, the serial enable on the power converter is set to "OFF", but only if parameter P079 (main contactor edge) is "OFF".
- * **Fast brake**
Contact X1:24 and F8 key on the PC
- * **Main contactor ON**
Contact X1:22 and F9 key on the PC

Main contactor ON

Function: Refer to Main contactor ON with communication source P001 = 0

Enable: Optionally by means of an edge change or a static signal (P079).
In the case of P079 = ON, an L ⇒ H switching operation must be carried out at input X1:22 for starting up and following an error and its removal. You must first press F9 on the PC and then apply the switching edge at X1:22.
In the case of P079 = OFF, the main contactor stays on. After removing the error, you can switch on the drive again by means of the serial enable (F7).
Switching off the main contactor edge is an option at commissioning, since you can completely operate the drive (enables and nominal values) from the PC if all the hardware enables are switched HIGH.

Inhibit: The drive is switched torque-free. After the armature current has dropped to zero, the power unit is disconnected from the mains via the mains connector. The drive coasts to a standstill without being braked.

In this case, contacts X1:23 and X1:24 do not affect the power converter.

Controller enable Refer to controller enable with communication source P001 = 0

Fast brake Refer to fast brake with communication source P001 = 0

Pulse inhibit Refer to pulse inhibit with communication source P001 = 0

• **Showing Controller Enables on the Power Converter's Display Using Parameter P106**

The upper bars show the status at input terminals X1:22 ... 24. The bars light up with a HIGH level

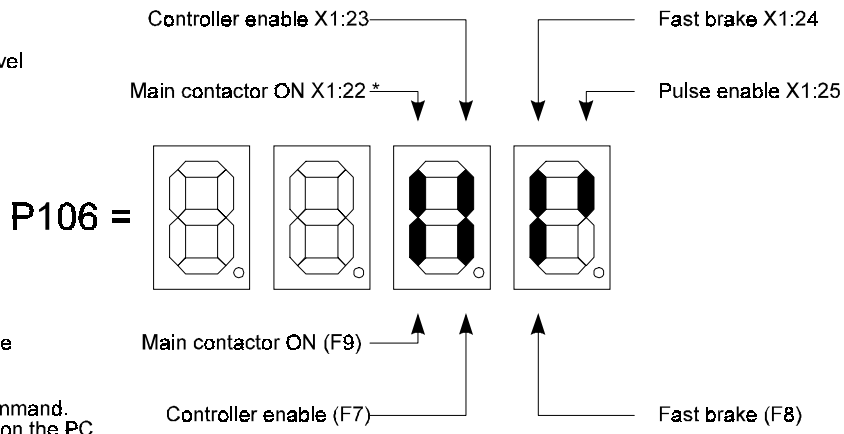

Lower bars show the status of the serial commands from the PC or the controller. The bars light up with an ON command. F7, F8 and F9 are function keys on the PC

* Display of the static status. The switching edge at X1:22 may still be missing for controller enable

6.7.2 Additional Switching and Control Inputs

Terminals X1:9, 26, 27, 28, 29

• **Programmable Input X1:9**

Parameter: P084=0 ... 13 (0 = no function)

As an analog input Possible current limiting modes:

- a) 0 ... +10 V corresponds to 0 ... 100% current limit
< 0 V corresponds to 0% current limit

Value	Meaning
1	Current limit of torque direction 1 variable Current limit of torque direction 2 = not influenced
2	Current limit of torque direction 2 variable Current limit of torque direction 1 = not influenced
3	Current limit of torque directions 1 and 2 variable, symmetrical

b)

10 (S04.21 and above)	0 V to +10 V corresponds to 0 to 100% external current limit for TD1 and 0% for TD2 0 V to -10 V corresponds to 0 to 100% external current limit for TD2 and 0% for TD1
11 (S04.21 and above)	0 V to +10 V corresponds to 0 to 100% external current limit for TD2 and 0% for TD1 0 V to -10 V corresponds to 0 to 100% external current limit for TD1 and 0% for TD2

Analog specification of the field current nominal value

8 (S04.05 and above)	Analog specification of the field current nominal value +10 V corresponds to 100% field current nominal value (referred to P049), -10 V to +1 V and terminal open corresponds to 10% field current nominal value. The field current nominal value is accepted with controller structures without field weakening only. (see also parameters P046, P049, P083)
-------------------------	--

As a switching input :

LOW level: 0 V or input open (approx. 0 ... 5 V)

HIGH level: 24 V (approx. 7.5 ... 30 V)

Switch-on hysteresis: approx. 5 V

Input resistance: 55 kΩ

With a HIGH level, the described action is carried out (except with P084 = 4)!

Nominal value multiplication:

Value	Meaning
4 (S04.15 and above)	The current nominal value is multiplied by the value of P149 once/while a LOW level is pending at terminal X1:9. This has no effect with P080 = 16

Polarity reversal of the nominal value

5	Nominal value polarity reversal switch (on the ramp function generator input)
---	---

Nominal value zeroing

6	Nominal value zeroing On the ramp function generator input without resetting the ramp function generator ⇒ ramp-down time effective
7	Nominal value zeroing On the speed controller input with resetting of the ramp function generator

Ramp function generator stop

9 (S04.17 and above)	Ramp function generator stop with a HIGH level at terminal X1:9
-------------------------	---

Automatic restart after brief mains power failures/power failure buffering/"Quick start"

Can only be used with communication source P001 = 0!

13 (S04.27 and above)	<p>Quick start (after a brief mains power failure) If there is a voltage of > +12.5 V on X1:9 when the electronics supply is connected, the system is initialized more quickly (approximately 800 to 900 ms) and the drive starts automatically, assuming that all the enables (X1:22 to X1:25) are available. In the case of an interruption of phase L2, for example, the restart takes approximately 500 to 600 ms.</p> <p>IMPORTANT!</p> <p>Terminal X1:9 may not be hard-wired; instead, you must control it by means of a contact, taking into account the machine's safety regulations.</p>
--------------------------	--

ON/STOP simulation

12 (S04.22 and above)	<p>ON/STOP simulation A special function that is only active with communication source P001 = 3</p>
--------------------------	--

• **Motorized potentiometer function**

Activation by means of P080: nominal value source = 10

Motorized potentiometer RPM higher/faster: X1:26 HIGH level

Motorized potentiometer RPM lower/slower: X1:27 HIGH level

If X1:26 and X1:27 are set HIGH at the same time, the motorized potentiometer stays at the current value.

Setting parameters:

P055: motorized potentiometer upper limit -99.9 ... +100.0%

P056: motorized potentiometer lower limit -100.0 ... +99.9%

P057: motorized potentiometer ramp-up time 0.1 ... 100.0 s (850 s S04.27 and above)

P058: motorized potentiometer ramp-down time 0.1 ... 100.0 s (850 s S04.27 and above)

The motorized potentiometer mode can be supplemented by the memory function:

P099: Inputs X1:28, 29 = 3 (refer to the next point entitled Programmable switching inputs)

Storing the current motorized potentiometer nominal value in the EEPROM: X1:28 LOW ⇒ HIGH switching operation

Approaching the stored motorized potentiometer nominal value: X1:29 HIGH

P059: Display of the motorized potentiometer nominal value

Display of the switching status conditions at terminals X1:26 ... 29 using parameter P108

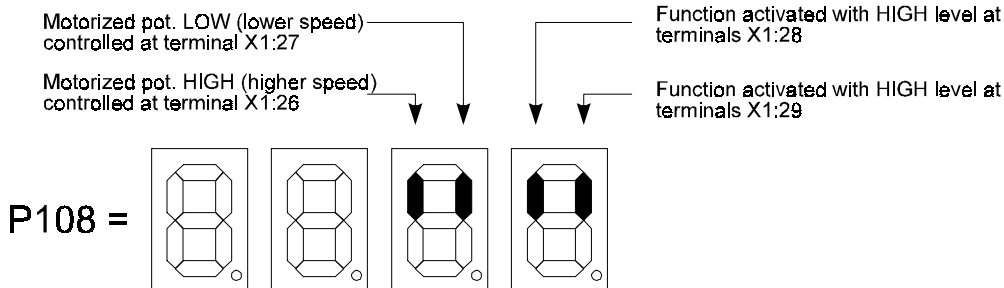

The segments are only lit up while there is a HIGH level on the respective terminal.

Example: RPM actual value in dependence on the individual motorized potentiometer functions

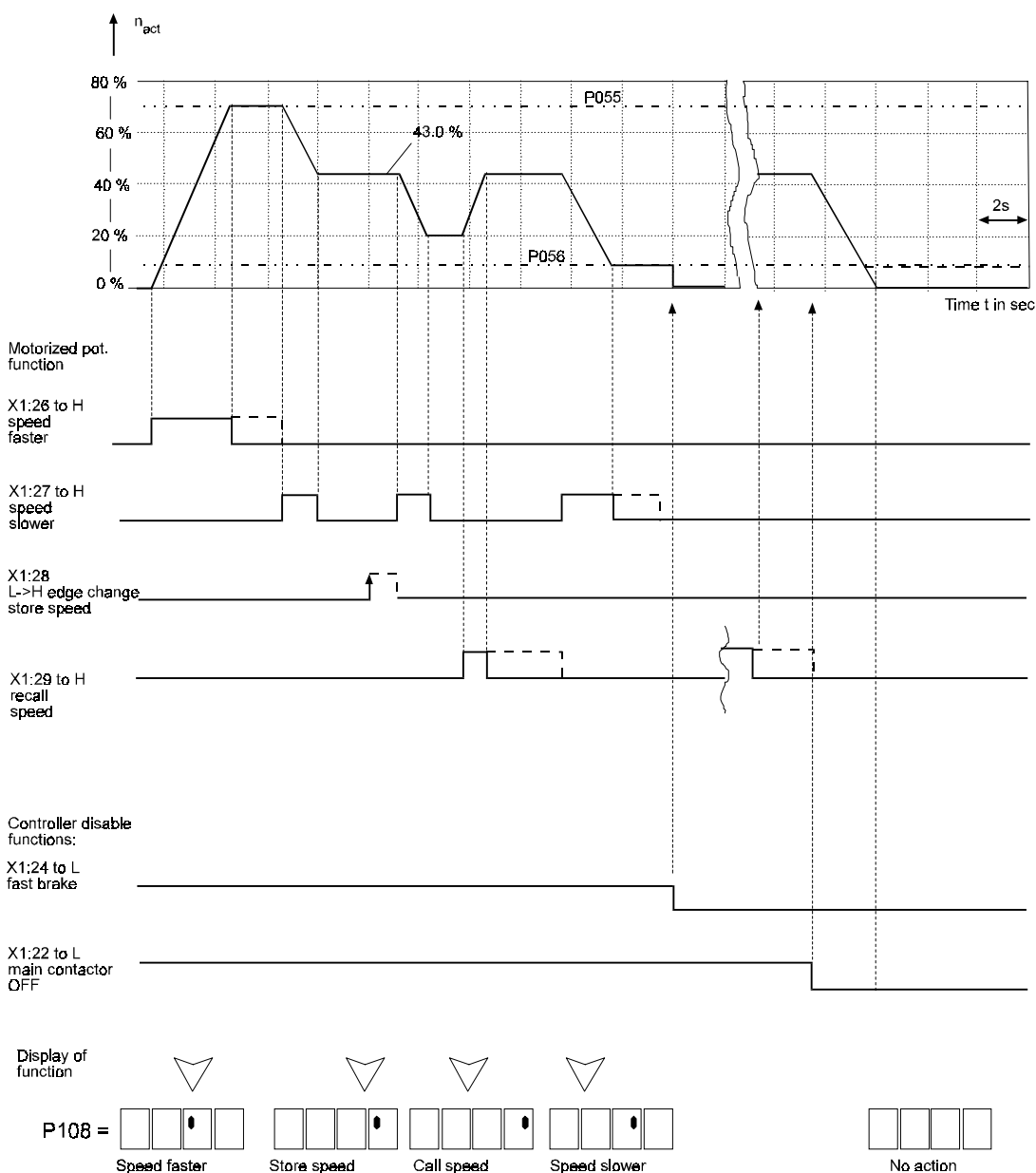

• Programmable switching inputs X1:28 and X1:29

Parameter: P099=0 ... 4

Value	Meaning
0	Switching inputs inactive
1	Inching mode Ramp function generator 2 is switched on automatically for the duration of inching mode. Once inching mode is finished, the original nominal value and ramp function generator apply. X1:28 HIGH level activates internal nominal value 1 (P051) X1:29 HIGH level activates internal nominal value 2 (P052)
2	No function
3	Motorized potentiometer memory function X1:28 LOW ⇒ HIGH edge change saves the current motorized potentiometer nominal value in the EEPROM (display with P059) X1:29 HIGH level: the system approaches the saved motorized potentiometer nominal value as soon as all the enables are active
4	Reloading and activating data sets The power converter gives you the option of programming various data sets. You can then call these blocks via the switching inputs on the microprocessor CPU as well as by means of the serial interface. When you do this, the system loads the selected data set from the EEPROM into RAM. X1:28 X1:29 LOW LOW No function, RAM data is unchanged HIGH LOW data set 1 LOW HIGH data set 2 HIGH HIGH data set 3 Parameter P099 = 4 must be set in all the data sets that are to be reloaded. Since it is not possible to secure switching over of data sets from impermissible or dangerous conditions, you must ensure with controller structure switchovers during operation, for example, that the system does not switch from field weakening to constant field. Refer to: Load data set mode (P148) If controller enable is applied during loading of a data set, controller enable is delayed until the data set has been loaded, regardless of the setting of P148. In addition, relay K4 "Drive ON" (P128 = 1) does not pick up until the drive has actually been enabled. Assuming that the controller is enabled and P148 = 2, and P099 = 4 and you then choose a new data set by means of terminals X1:28 and X1:29 on PCB 3.8934 and if the signals at these terminals are retained, the new data set is loaded immediately when the controller is inhibited! The setting of parameter P148 does not affect P118 "Gear stage". You can therefore change the protective circuit of the speed controller at all times, i.e. even when the controller is enabled. See also parameter P008. P148 = 1: Data set can always be loaded, i.e. even when the controller is enabled P148 = 2: Data set can only be loaded with the controller inhibited. If the system tries to load a data set with the controller enabled, message 113 is issued.

6.7.3 Sequence of Switching On and Off

You must apply and remove the mains voltage to the mains unit (X2:1, 2), the field supply (X2:6, 7 or X3:1, 2) and the power unit (AK1, AK3, AK5) according to the guidelines below and take into account the enable criteria described in Chapter 6.7.1:

In this context, see also the connection suggestions and connection information in Chapter 5, Installation.

Check the phase coincidence of the three connection voltages, otherwise error messages of P159 will be issued: e.g. 02 (anti-clockwise rotating field on power unit connection), 45 (field connection not correct), 46 (power unit connection not correct).

- **Switch-on sequence**

We recommend that you proceed as follows:

- Connect the mains unit and the field supply to the mains at the same time, here, at the latest, apply pulse enable.

NOTE

By means of "Pulse enable", the hardware enables the firing pulses for the armature and the field. In the standard unit configuration, the system tests the field connection at switch-on (mains unit connected to the mains) or after a reset at initialization.

A delayed pulse enable triggers error message 24 (min. field current out of lower range). If the field current is switched-in too late, the system additionally displays error message 45 (field connection not correct).

With motors that have a very high field time constant, the system may issue error message 24 (min. field current out of lower range) despite the procedure being correct.

Remedy: Increase P117 (response time of I_F monitoring) or use one of the variants listed below.

- Trigger the line connector for the power unit by means of "Main contactor ON" via relay K1 (terminals X2:3..5) on the power converter (with P124 "main contactor/controller inhibit function" = 1).

NOTE

With P124 "main contactor/controller inhibit function" = 2, the system additionally switches off the main contactor with "Fast brake" and $n < n_x$.

P124 Drive inhibit function

Value	Meaning
1	Fast brake Controller inhibit at $n < n_x$ (P078) Main contactor stays on,
2	Fast brake In addition, the main contactor is switched-off at $n < n_x$ (P078), at enabling. Cancel fast brake must be applied before Main contactor ON..

To reenale the power converter, you must apply Cancel fast brake before Main contactor ON.

Depending on the setting values of P001 and P079, the following enable procedure results:

P001 Communication source (can only be changed with keypad)

Input Value	Meaning
0	Keyboard on power converter
1	Service PC
2	Control via interface board
3	Control via interface board and keyboard input

P079 Main contactor edge (can only be switched off when P001 = 1, 2 or 3)

Value	Meaning
ON	At switch on or after an error and its removal, an L ⇒ H switching operation must take place at input X1:22.
OFF	The main contactor stays on; after the error has been removed, you must switch on the drive via the serial enable of the drive.

P001 = 0, P124 = 2

or

P001 = 1, 2, or 3, P079 = ON, P124 = 2:

Initial position: The drive was shut down by means of "fast brake" at terminal X1:24 and the main contactor dropped.

- "Main contactor OFF" at terminal X1:22, "Controller inhibit" at terminal X1:23 *
- "Cancel fast brake" at terminal X1:23
- "Main contactor ON" at terminal X1:22
- Apply "Controller enable" at terminal X1:23 with a delay of at least 1.4 s: this results in delay-free starting. *

* See next page

P001 = 1, P079 = OFF, P124 = 2

See above for the initial position, software enable F9 for "Main contactor ON" was cancelled internally

- Apply "Controller enable" at terminal X1:23 or cancel software enable F7 (controller enable). *
- "Cancel fast brake" at terminal X1:24
- Apply software enable F9 for "Main contactor ON"
- Apply "Controller enable" for delay-free start-up (X1:23/F7) *

* "Controller enable" may also be permanently pending; in this case, however, you must take into account the delay of a maximum of 1.4 s between applying "Main contactor ON" and start-up of the drive.

- As the final step in defined and delay-free start-up, apply "Controller enable" or "Cancel fast brake" (or both of them at the same time).
Take into account parameter P124!

As an alternative, the following variants are possible:

- Field supply
 - This may be connected to the mains before the mains unit without any additional measures being needed.
 - With P122 (Field feed in monitoring) = OFF, it is also possible to connect the field to the mains after the mains unit.
At the latest, you must connect the unit to the mains on applying the "Main contactor ON" enable command, since the system checks the field connection and activates the field monitoring relay.
- Line contactor for the power unit
 - Connection to the mains is possible without using relay K1 on the power converter.
The power unit may be connected to the mains before the mains unit.

NOTE

Unit sizes III and IV

In the case of units up to and including software version 04.16, if you are not going to use the function of relay K1, "Main contactor ON" on the power converter on PCB 3.8942 (terminals X2: 3 ... 5), you must wait at least five seconds after switching in mains unit (X2:1, 2) before you are allowed to connect the power unit to the mains.

The power contactor must switch in on the "Main contactor ON" command at the latest, otherwise the system issues an error message.

- **Switch-off sequence-**

NOTE

Never disconnect the power unit from the mains until the firing pulses are in the inverter limit and the armature current has dropped to zero.

Ignoring this procedure can lead to the fuse dropping. In a worst case situation, the thyristors can be damaged.

For this reason, you should always cancel one of the enable conditions (except for pulse enable!) first.

You decide how you want to shut-down the drive :

- Cancel the "Main contactor ON" command:
This immediately resets the pulses into the inverter limit and sets $I_A = 0$, the mains contactor is then switched off via K1 (X2: 3 ... 5).
- Cancel the controller enable which has the same effect as "Main contactor OFF" but without switching the main contactor.
- Fast brake “
Braking to $n = 0$ either at the current limit or at the ramp of the ramp function generator; then the system carries out an internal controller inhibit ($I_A = 0$) with or without switching off the main contactor contact (P124).

After this, first disconnect the power unit from the mains (if this has not already been done by one of the controller inhibit commands), then disconnect the mains unit and the field power converter. Switching off the field power converter before the mains unit triggers error message 24 (min. field current out of lower range).

6.8 Automatic Restarting after Brief Mains Disturbances

This function is intended to prevent the power converter being disturbed in the case of short mains failures or brown outs, and then having to be enabled again by the controller when power is returned.

A total of three variants are available that are activated depending on the unit version, i.e. standard version with conventional mains unit in the power supply, special version with switching power supply.

NOTE

Only when the power converter is rectifying is it possible to guarantee safe operation in the case of a power failure.

6.8.1 Standard Unit

Type codes of the units:

BKF12/... .. - 6 04 00 ..

BKD06/... .. - 6 04 00 ..

For this, programmable input X1:9 is needed; parameterize P084 = 13!

NOTE

This function can only be used with communication source P001 = 0.
Parameter P147 must be set to "OFF" and P156 must be set to 0.0 s.

The function is available with software version S04.27 and above!

With the standard unit, even very short power failures can lead to the failure of its power supply; this means that when power is returned, the power converter must be reinitialized. Since the unit was operating properly before the power failure, the system knows the connection conditions on the mains side (rotary field on the power unit, phase relation of the connections on the mains unit, the field supply and the power unit). As a result, shortened initialization is needed at the restart. This is always carried out if input X1:9 is HIGH and all the enables (X1:22 ... 25) are pending.

Circuit diagram and principle of operation:

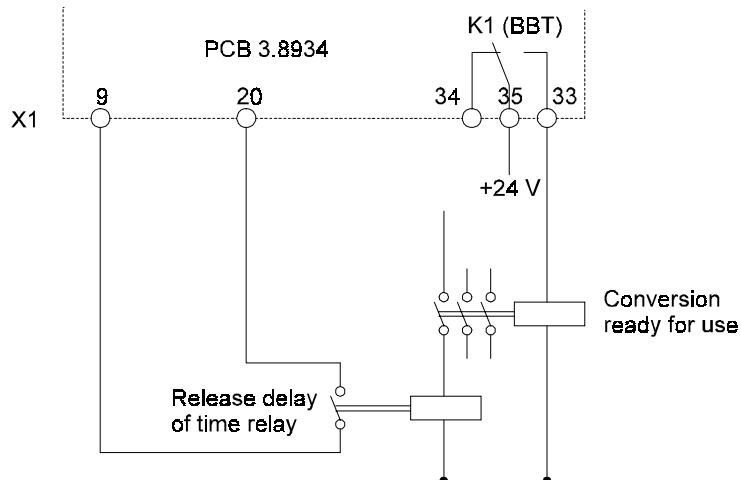

After applying the supply voltage to the power converter's mains unit, relay K1 (BBT) on PCB 3.8934 stays dropped until booting is completed. Only then is programmable input X1:9 switched HIGH via the externally fitted relay. This means that the normal initialization sequence takes a maximum of 3 to 4 seconds.

With a brief mains failure, by contrast, the dropout-delay relay stays picked-up and applies +24 V to input X1:9 immediately on restoration of power. As early as the start of the initialization stage, the system interrogates the input with regard to the automatic restart; because of this, a shortened initialization period of 500 to 900 ms will result.

The time needed for initialization depends on the type of mains disturbance (one or several phases disturbed, the affected phases, etc.).

The user specifies the length of the buffering period on the time relay.



WARNING

Terminal X1:9 may not be hard-wired; instead, you must control it by means of a contact, taking into account the machine's safety regulations. It is vital to prevent shortened initialization on switching on for the first time!

6.8.2 Automatic Restart for Special Versions with a Switching Mains Unit

Type codes of the units:

BKF12/.../... - 6 04 01 ..

BKD06/.../... - 6 04 01 ..

With this version, you can use the function in two ways:

- buffering mains disturbances lasting up to 400 ms
- buffering relatively long mains disturbances lasting up to 6 s

Both variants have the following in common:

During the mains disturbance, all the controller enables on the unit must stay active.

As soon as the power converter has detected a mains disturbance, internal measures inhibit the drive which is then torque-free. This can lead to a serious drop in the speed or even to a machine standstill.

If relay K4 is assigned the function "Drive on" (P128 = 1), it reports "Drive inactive" for the duration of the internal controller inhibit.

To suppress error message 24 (min. field current out of lower range) during the mains failure, you must, if necessary, adapt the field current monitoring relay's using parameter P117. The initializing period at restarting lasts 400 ... 500 ms.

You may not program parameter P084 with the value 13.

- Special features in the case of mains failure buffering for a maximum of 400 ms
You must program parameter P147 ("Phase failure < 400 ms") to ON; set parameter P156 ("Mains failure timeout") to 0.0 s.
With mains failures that last longer than 400 ms, the drive stays disabled.
This variant for buffering mains failures with the help of the integrated switching mains unit is available with S04.17 A and above.
- Special features in the case of mains failure buffering for up to 6 s
This function can only be carried out with an external 24 V., 50 W UPS. You must connect the supply voltage to terminals X34:1, 2 (+24 V to X34:2, GND to X34:1) on PCB 3.9415. Reverse voltage protection is contained in the unit (see also 5.2.1, Connection Plan).

NOTE

The user must enforce external measures to ensure that the starting current inrush on connection of the 24-V UPS does not exceed 50 A!

This starting current inrush is caused by the buffer condensers in the unit.

Options for limiting the starting current inrush

- Use an external power supply with current limitation
- Limit the current by means of a series resistor (rated at $\geq 0.5 \Omega$, 4 W). The resistor may be permanently switched-in if it can be guaranteed that the permissible input voltage range will not be fallen short of ($U_{inp} = 21 \text{ V} \dots 30 \text{ V}$, current consumption 1.7 A max.)
Otherwise: the resistor is shunted-out after 100 ms at the earliest (this applies to $R = 0.5 \Omega$, higher resistances require an on period that is appropriately longer).
- Switching-in the external 24 V is possible without additional current limiting, assuming that it can be guaranteed that:
 - a) the external 24 V is applied at least 100 ms after the mains voltage (at terminals X2:1,2)
 - b) the mains voltage is within the tolerance band of 400 V/460 V/500 V +10% -15%.
Under no circumstances is switching through without additional current-limiting measures allowed in applications in which the switching power supply is used for adaptation to different mains conditions!

Using P156, "Mains failure Timeout", set the bridging period in the range 0.0 ... 6.0 s. Set parameter P147 ("Phase failure < 400 ms) to OFF!

This function is available with S04.29 and above.

6.9 Load Measurement with Cranes (S04.12 and above)

Load measurement is needed with the hoisting mechanisms on cranes if the drives are run with field weakening control.

Field weakening characteristic:

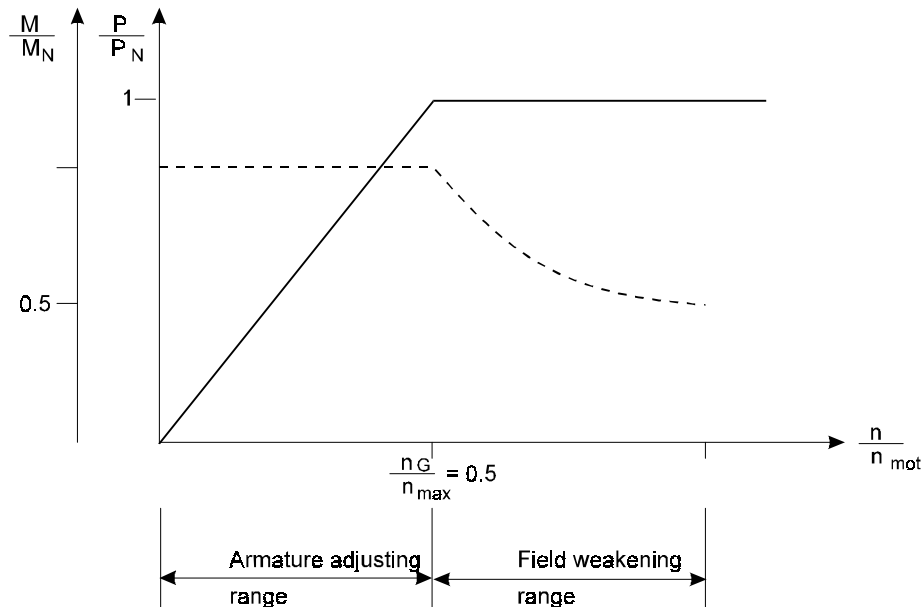

In the field weakening range, the system is run at constant power from the basic speed, n_G , onwards. As a result, the available driving torque ($P = \text{const.} = M \cdot \omega$) reduces as the speed increases. As the diagram above shows, with a field weakening range of $\frac{n_G}{n_{max}} = 0.5$ only half the rated torque is available at maximum speed. You can determine intermediate values by means of the relationship $n = \frac{M_N}{M} \cdot n_G$.

The drive torque M_a that the motor requests is composed of the sum of the load torque M_L and the accelerating torque M_b : $M_a = M_L + M_b$.

The speed specified is routed via the unit's start-up integrator, which ensures that drive start-up is load-independent. As a result, you can determine as early as the commissioning stage the dynamic component, M_b , of the drive torque (P133: acceleration factor) by means of an optimization run (P086 = 6 and no load).

At the start of commissioning, you should also determine the system losses by means of tests (of the motor, the transmission, other friction losses). You can enter these in the form of a P135, "Transmission efficiency". The value is set correctly when the same load value is determined when lifting and lowering the same load.

If you measure the motor current while traversing the armature adjusting range ($n = 0$ to n_G), you can directly derive the load torque M_L taking into account the acceleration and friction torques.

In practice, measurement is carried out between 20% and 80% of the motor's basic RPM speed. To activate load measurement, the system must run from a speed that is less than 20% of the basic RPM speed to a speed in the range 20% to 80% of the basic RPM speed. After exceeding the 80% value, load measurement is switched off and the system stores the value which was previously determined. Load measurement is not activated if the system runs from a higher speed into the measuring range.

By means of the load torque, M_L , derived in this way, it is possible to draw a direct conclusion about the moved load. This load can be measured on one of the analog output channels if the channel is parameterized with the value 40. In this connection, +10 V represents a load of 100%.

You can determine the measuring results with an adequate level of precision if the ramp-up time of the integrator's nominal value is set to at least $\frac{4}{3} \cdot \frac{n_{\max}}{n_G}$ approximately. With a field weakening range of $\frac{n_{\max}}{n_G} = 2$, this is a ramp-up time of around 3 seconds.

The value for the load is used to calculate the maximum possible speed nominal value to which the ramp function generator input is limited. (See Function Plans: Nominal Value Setting).

You need the following parameters for load measurement:

- P023** **$I_{A_{\text{mot}}}/I_{A_{\text{max}}}$**
Here, you enter the motor's overload factor.
- P081** **Optimization run**
P081 = 6: Determining the acceleration factor
- P088** **Analog output channels 1 ... 4**
- P089** 40: Load torque
- P130** 41: Permissible speed nominal value

- P125**
- P132** **Scaling analog output channel 2/4**
- P094**
- P100** **Ramp generator 1/2**
- P095**
- P101** **RG 1/2 acceleration time**
- P096**
- P102** **RG 1/2 deceleration time**

P133 Acceleration factor

This value can be determined by optimization run P081 = 6 no load(!). After setting the optimization run, you must set a nominal value that is higher than the basic RPM speed. As soon as the speed is higher than 80% of the basic RPM speed, the system finishes the optimization run and determines the acceleration value. See also parameter P167.

P134 Field weakening range

You must enter the field weakening range of the motor being used. The system then uses this value to calculate the basic RPM speed and the limit values for the RPM window to determine the load.

P135 Gear efficiency factor

You must enter the efficiency of the transmission being used. If you do not know what it is, you must carry out tests to determine it. Even if you do know the efficiency, tests under load are necessary. The value is set correctly when the same load value is determined when lifting and lowering the same load.

P136 Load measurement ON/OFF

This parameter must be ON to allow load measurement to be carried out in the specified speed window. This parameter must also be ON to determine the acceleration factor, otherwise the setting of P081 = 6 is not accepted.

P160 n_nom limit mode

Value	Meaning
1	Calculation of the maximum permissible speed at load measurement with constant power (hyperbola; $Load \cdot n_{per} = constant$)
2	Calculation of the maximum permissible speed at load measurement on three straight sections (4 interpolation points). Effective parameters P161 ... P167

P161 to

P166 n-interpolation points

Speed and rotary torque values for the characteristic curve in the field weakening range at P160 = 2.

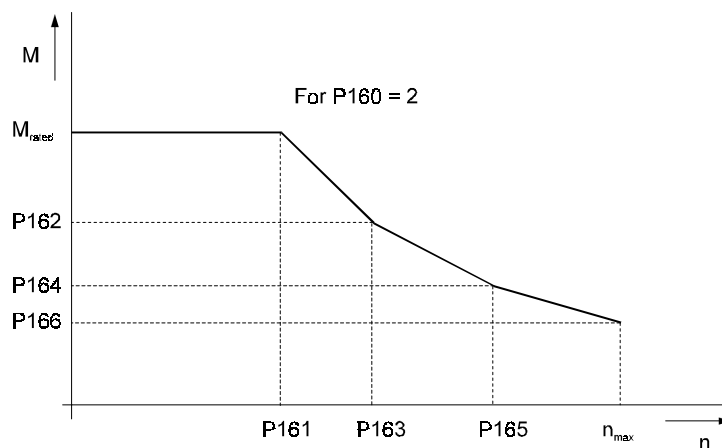

P167 Base load

This is needed to determine the acceleration factor, P133. Optimization run P081 = 6 must be carried out with no load (spreader empty). Before carrying out the optimization run, you must enter the basic load (weight of spreader/rated load). The value is not stored in the data set and is of no consequence during load measurement!

Example:

Weight of spreader	of 10 tonnes
Max. loading	40 tonnes
Rated load	50 tonnes
Basic load	10 t/50 t = 0.20
P167	20%

P168 Lower measuring limit

Lower limit of the load measuring range. The default value is 20% of the basic RPM speed.

P169 Upper measuring limit

Upper limit of the load measuring range. The default value is 80% of the basic RPM speed.

7 COMMISSIONING

7.1 Danger and Warning Information



WARNING

This equipment carries a dangerous voltage and contains dangerous rotating parts (fans). Ignoring the safety and warning information may result in death, severe personal injury or damage to property.

You are responsible for mounting the power converter, the motor, the commutating reactor and any other equipment in accordance with appropriate safety regulations (e.g. DIN, VDE); equally, you must ensure that all other relevant national and local regulations are met with regard to cable ratings and protection, grounding, disconnectors, overcurrent protection, etc.

The most important factors for protecting people are the DIN/VDE protective measures and safety regulations. If there are no protective earth connections on the equipment, commutating reactor or the motor, personal injuries are inevitable, since the surfaces may carry dangerously high voltages.

The power converter's power cables are energized!
The DC side is not galvanically isolated from the mains!

The mains unit and the field connector of the power converter carry a dangerous voltage even when the main contactor has dropped.

During operation, the principles on which the power converter and the motor work lead to leakage currents to earth that are dissipated via the specified protective earths and may result in a current-operated e.l.c.b on the input side blowing prematurely.

In the case of a short-circuit to frame or to ground, a direct proportion may arise in the leakage current that makes triggering a higher level current-operated e.l.c.b either more difficult or totally impossible. Make the PE connection in accordance with DIN EN 60204/VDE 0113 Part 1/06.93; Section 8.2.2 taking into account provisional standard EN 50178/ VDE 0160/11.94, Sections 5.3.2.1 and 8.3.4.4.

Before carrying out commissioning, check whether the plastic covers over the power stage connections are in place.

You may only reset the power converter with the controller disabled **and** the motor idle.

If an error occurs, the drive is deenergized and then coasts unbraked to a standstill. You should consider this situation particularly with motion and lifting drives.



WARNING

Faulty drive response

During initial commissioning, faulty or uncontrolled motion of the driven machine elements is always possible. At this stage, you should therefore proceed with particular care.

Before switching on the drive, you must carefully check the functions of all the higher level safety equipment to prevent injury to people.

Take particular care when directly or indirectly touching the drive shaft with your hand. This is only allowed when the shaft is stationary and the power converter is deenergized. Any exposed parts of the machine, such as the shafts, fans, etc., must be covered during operation.

Contact Protection In Accordance with Paragraph 4 Section 4 VBG 4

Protection against direct contact comprises all the measures against danger that can result from touching the active parts of electrical equipment.

You must therefore protect the active parts from being touched by means of insulation, the construction and arrangement of the equipment or directly mounted guards. The guards in question are standard covers, barriers and procedures that guarantee that people cannot touch active parts that are carrying power.

Switching cabinets must have an emergency off facility to switch off any voltages that could be dangerous. This does not include equipment which, if switched off, would cause an even more dangerous situation. The emergency off releasing element must be arranged in such a way that it can be reached quickly in case of danger. In the case of work that is considerably more dangerous than usual, another person **must** be present.

The machine minder must ensure that unauthorized people do not work at the machine.

The machine minder must report immediately any changes that occur at the machine which adversely affect safety.

When dismantling safety equipment during commissioning, repair and maintenance work, you must ensure that the machine is taken out of commission in accordance with applicable regulations. You must remount and check safety equipment immediately after completing commissioning, repair and maintenance work.

NOTE

When commissioning using a PC, you must connect the interface cable to the power converter's RS 232 service interface.

For safety reasons, you are advised to only handle this plug with the motor idle and the controller disabled.

Observe electrostatic discharge protection: Before touching the plug, discharge electrostatic energy from your body by touching a grounded conductive object, for example.



WARNING

Follow the safety information on the motor and tachometer in the appropriate operating and maintenance instructions.

Avoid any working practices that jeopardize safety at the machine.

After carrying out any work involving intervention in the drive – regardless of whether this involves the motor, actual value acquisition or the power converter – the owner must carry out acceptance testing of the machine and document it chronologically in the machine log (maintenance manual or similar). Failure to do this may result in the owner being faced with consequences relating to liability legislation.

This is not a complete list of all the procedures necessary for safe operation of the unit. If you need further information or have particular problems, contact BAUMÜLLER NÜRNBERG or one of our distributors.

Observe the warning information in chapter 1 of these operating instructions.

NOTE

- Before touching the modules, you must discharge electrostatic energy from your body to protect electronic components from high voltages resulting from electrostatic charging. The easiest way to do this is to touch a grounded conductive object before handling components.

Units containing components or modules at risk from electrostatic energy are clearly marked as such by the sticker below.

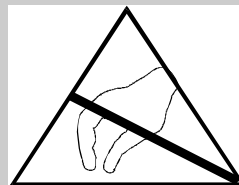

- **Electromagnetic Compatibility (EMC) Measures**
Due to the principle of operation, power converters produce conducted and radiated high-frequency energy. Eliminating interference in power converter-controlled drives is technically very complicated. It is made even more difficult, since the assembly of individual components means that impedance and interference conditions are not consistent. For this reason, German law demands that the manufacturer or owner of the complete unit, rather than the manufacturer of the individual components eliminates interference in accordance with applicable regulations.

7.2 Operating the Power Converter

7.2.1 Overview

Series 6000 power converters are set by means of parameters and parameter values. The following procedures are possible:

- **Setting using the keypad and display on the power converter**

No additional aids are needed

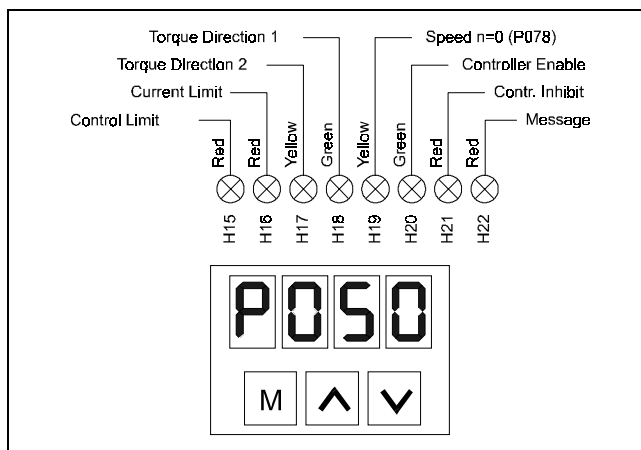

- **Setting using a PC with operating software, online operation**

Advantages:

- easy handling by means of menus
- direct comparison possible between the specification and the drive's response
- actual values and enables are constantly shown at the bottom of the menu
- complete documentation on a printer is possible after work is completed

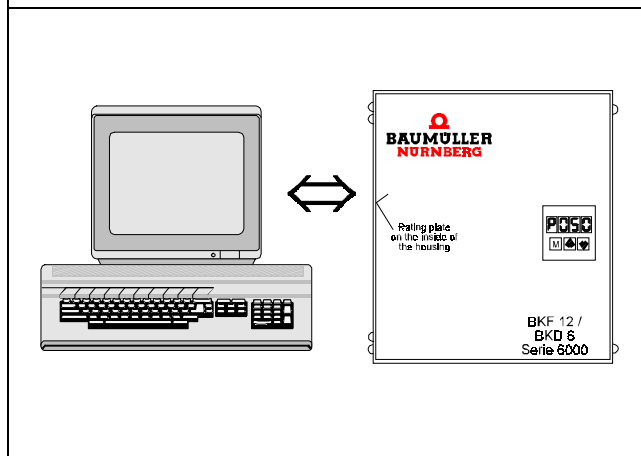

- **Setting using a PC with operating software, offline operation**

Advantages:

- calculation of setting values in advance
- easy offline handling
- actual values/enables are not displayed, since the unit is not connected
- fast transfer of data at the machine from the PC to the drive by means of floppy disks
- short commissioning times
- absolutely identical setting values and, with this, identical properties with the same applications

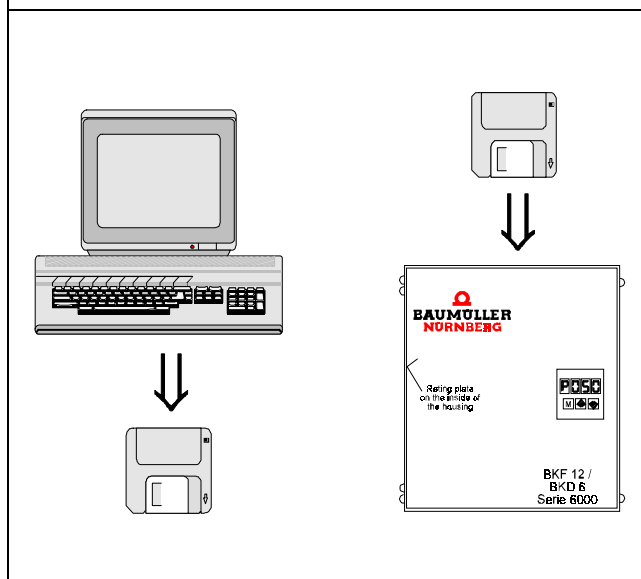

- **Parameterizing by means of the controller and the optional interface boards**

Advantages:

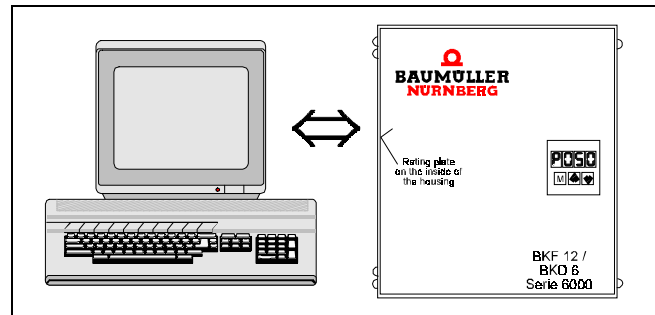

- flexible adaptation of parameters when operating conditions change by directly accessing RAM



7.2.2 Keypad and Display on the Power Converter

The keypad for manual parameterization is at the bottom right of the power converter's microprocessor PCB 3.8934.



It has three keys:

- Mode 
- Higher 
- Lower 

Directly above it is the four-character seven-segment display for showing parameters, parameter values and any errors that may have occurred.



Functions of the keys:

- Mode key 
 - Changing between Choose parameter mode and Set parameter value mode
 - In Choose parameter mode, the system cyclically ($f = 0.33$ Hz) displays the parameter number and its associated value one after the other. The parameter number is shown for 1 s; the parameter value is displayed for 2 s.
 - Transfer of the displayed parameter value to RAM on changing from Set parameter value mode to Choose parameter mode
 - Programming a data block in the EEPROM with P004 = 1, 2, 3 or 4
 - Acknowledging error messages with parameter P005



- Higher key 
 - Choosing higher parameter numbers in Choose parameter mode
 - Increasing the set parameter value in Set parameter value mode
- Lower key :
 - Choosing lower parameter numbers in Choose parameter mode
 - Decreasing the set parameter value in Set parameter value mode

Handling the keypad

NOTE



On pressing either the  or  key to choose another parameter number or another parameter value, the system first counts up or counts down the displayed number/value in a 250-ms cycle. If you keep the key pressed for more than 20 counting operations, the counting frequency increases five-fold.

- **Switching on the display :**

Press  or  once for at least one second.

When you release the key, the display lights up. The operating unit is now in Choose parameter mode (the system cyclically displays the parameter number and the parameter value one after the other)





- **Switching off the display:**

In Choose parameter mode, press  or  to select parameter P103 and then press the  key twice.

NOTE

The display is switched on manually (see above) or by a power converter error message (S04.08 and above). In the event of an error, the system cyclically displays one after the other parameter P159 and the number(s) of the pending error(s).

- **Enabling the keypad: P104 = 17**

- In Choose parameter mode, use the  or  key to select parameter P104
- Press the  key once
- Use  to set the value 17
- Press the  key again

NOTE

After transfer, the value 17 is not displayed!

With P104 = 17, the keypad has input rights on the unit, assuming that P001 = 0 or 3. During counting up of the parameter value, you should briefly release the  key once to keep to the low counting frequency. Otherwise the frequency would increase five-fold at the value 14 (see above).

- **Disabling the keypad**

See Enabling the keypad. All values for P104 that are not 17 disable the keypad for manual inputs. Display of parameter values is still possible. Changing P001 automatically disables keypad input.

- **Changing and activating parameter values**

- Use \uparrow or \downarrow to set the desired parameter
- Press the M key to change from Choose parameter mode to Set parameter mode
- Press \uparrow or \downarrow to choose the desired value
- Press the M key once: The value is stored in RAM and the keypad is in Choose parameter mode again

- **Storing parameter values**

Program the EEPROM with a data block (1 ... 4).

NOTE

During commissioning, it is advisable to save (i.e. transfer to the EEPROM) changed data frequently. You can only program a data block when the controller is disabled!

- Use \uparrow or \downarrow to set parameter P004
- Press the M key once
- Press \uparrow or \downarrow to choose the desired data block (1 ... 4)
- Press the M key once: Changing to Choose parameter mode transfers the data block to the EEPROM.

- **Changing the communication source: P001 = 0 ... 3**

- 0: Keypad on the power converter
- 1: Service PC
- 2: Control via optional interface board
- 3: Control via interface board and keypad

Changing of the communication source is possible **manually** on the keypad only.

The factory default parameterization of the unit is P001 = 0 (keypad).

Every time you change the communication source, the main contactor drops and the keypad is locked. With the change to P001 = 0, you may have to enable the keypad again.

This is not necessary with the change to P001 = 1, since the PC is accepted as the communication source without the keyboard needing to be reenabled.

The system displays parameter P001 to one decimal place. In this connection, the place before the decimal point indicates the communication source stored in the EEPROM. (Exception: With EEPROM programming, a 9 is shown). The place after the decimal point shows the communication source that is currently stored in RAM.

Two examples of changing the communication source:

a) From keypad to PC operation

Starting point: The keypad is enabled and in Choose parameter mode

- Use \uparrow or \downarrow to choose parameter P001: The display alternately shows P001 and then 0.0.
- Press the M key once: Value 0.0 is now shown permanently (Set parameter value)
- Keep pressing \uparrow or \downarrow until 0.1 appears
- Press the M key once: Operation on the Service PC is now set and the value 1 has been stored in the EEPROM. The system shows 1.1 in the display to confirm this fact.

NOTE

This change of setting is always necessary if the power converter was commissioned with the PC and you want to run it later without communications. If you do not reparameterize, on disconnection of the PC the system issues error 18 (data traffic interrupted for longer than 1200 ms) and inhibits the controller.

b) Reparameterizing from PC operation to keypad

- First unlock the keypad (P104 = 17). You can use the keypad or the user program to choose parameter P104.
- Choose parameter P001: The display cyclically shows P001 and the value 1.1 one after the other
- Press the M key once: 1.1 is shown (Set parameter value mode)
- Keep pressing \uparrow or \downarrow until 1.0 is shown on the display.
- Press the M key once: Changing operating modes (from Set parameter value to Choose parameter) stores the value 0 in the EEPROM. This parameterizes the communication source to keypad operation and the display alternately shows P001 and 0.0.

7.2.3 Operation Using a PC

An IBM-compatible PC with at least one serial port (COM1) is adequate for parameterization and commissioning

The plug for connecting to the power converter's RS232 service interface is at the bottom right of microprocessor PCB 3.8934 (X2 with PCB version 3.8934C and X3 with version 3.8934E).

NOTE

For safety reasons, you are advised to only handle this plug with the motor idle and the controller disabled.

Observe electrostatic discharge protection: Before touching the plug, discharge electrostatic energy from your body by touching a grounded conductive object, for example.

Two cables are available that match the most common types of PC serial ports. On the PC side, cable 8230383 has a 25-pin SUB-D female connector whereas cable 8230553 is fitted with a 9-pin SUB-D female connector (see also 5.8 Accessories).

In addition, you need the user software which is supplied on a 3.5" system floppy disk (the disk must not be write-protected!)

The floppy disk contains the following files:

S04xx.EXE

S04xx_D.EXE (software version S04.20 and above)

S04xx_E.EXE (software version S04.20 and above)

D04xx.68k

Up to version S04.19, the user program is available in German only; from version S04.20 onwards, both German- and English-language versions are obtainable. The language is shown by the addition of _D (for German) or _E (for English) to the filenames.

Series S04xx.EXE user programs – like the equipment user software S04.xx – are upward-compatible. This means that, although it is advantageous to use the two matching software packages with the same system designation, it is not absolutely necessary.

If you utilize user software with a lower version number, it may not be possible to control some parameters at all or control may only be within limited operating ranges (refer to the chapter entitled Parameters). Before the release of the most current software, it is therefore advisable to initially commission the equipment using the existing program. After this, you can change the communication source and manually set the parameters on the keypad that cannot be operated.

In the opposite case, i.e. if you utilize user software with a higher version number, the system displays the problem parameters while UPLOADING or DOWNLOADING during online operation (described in the next point). If you do not need this list of parameters, you can continue commissioning without problems. Otherwise, you need current EPROMs for the user software.

Calling the user programUp to and including software version S0419.EXE:

S04xx [BW] [COM2]

with the switches:

[BW] if your system has a black and white screen

[COM2] if you are using the second serial port

There must be a space between each of the switches [...].

– Software version S0420.EXE and above:

S04xx_D [BW] [COM2] if you are using the German version

S04xx_E [BW] [COM2] if you are using the English version

with the switches:

[BW] if your system has a black and white screen

[COM2] if you are using the second serial port

There must be a space between each of the switches [...].

The user program is menu-driven and is easy to handle.

To choose the individual menu items, you can either use the arrow keys to move to the item and then press the Return key or simply press the initial letter of the menu item.

After the program has started, the system menu below is displayed:

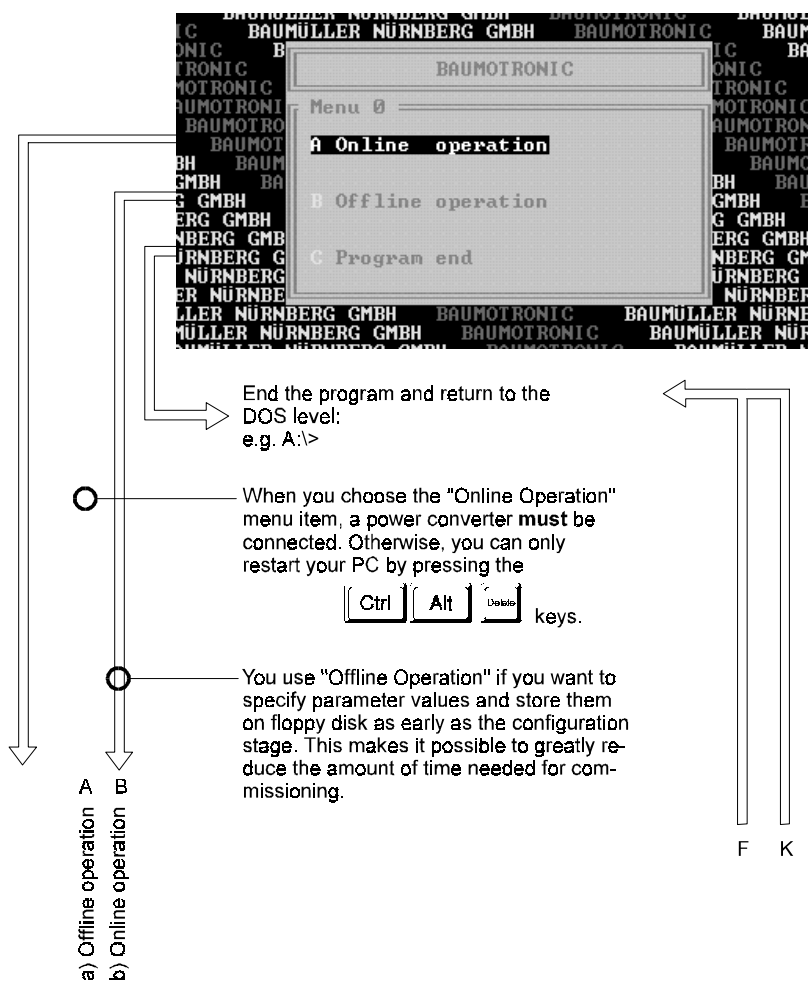

a) Offline operation

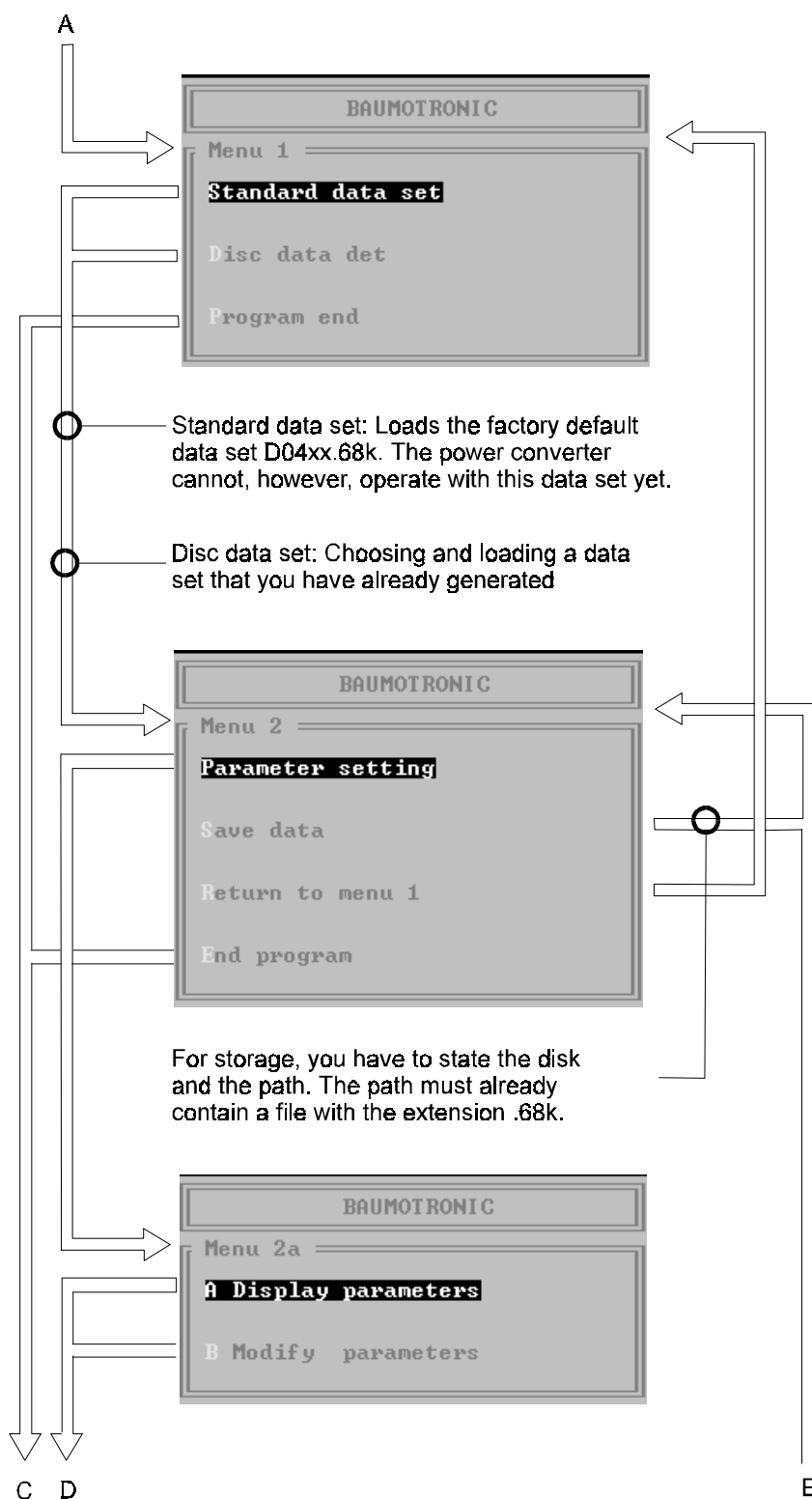

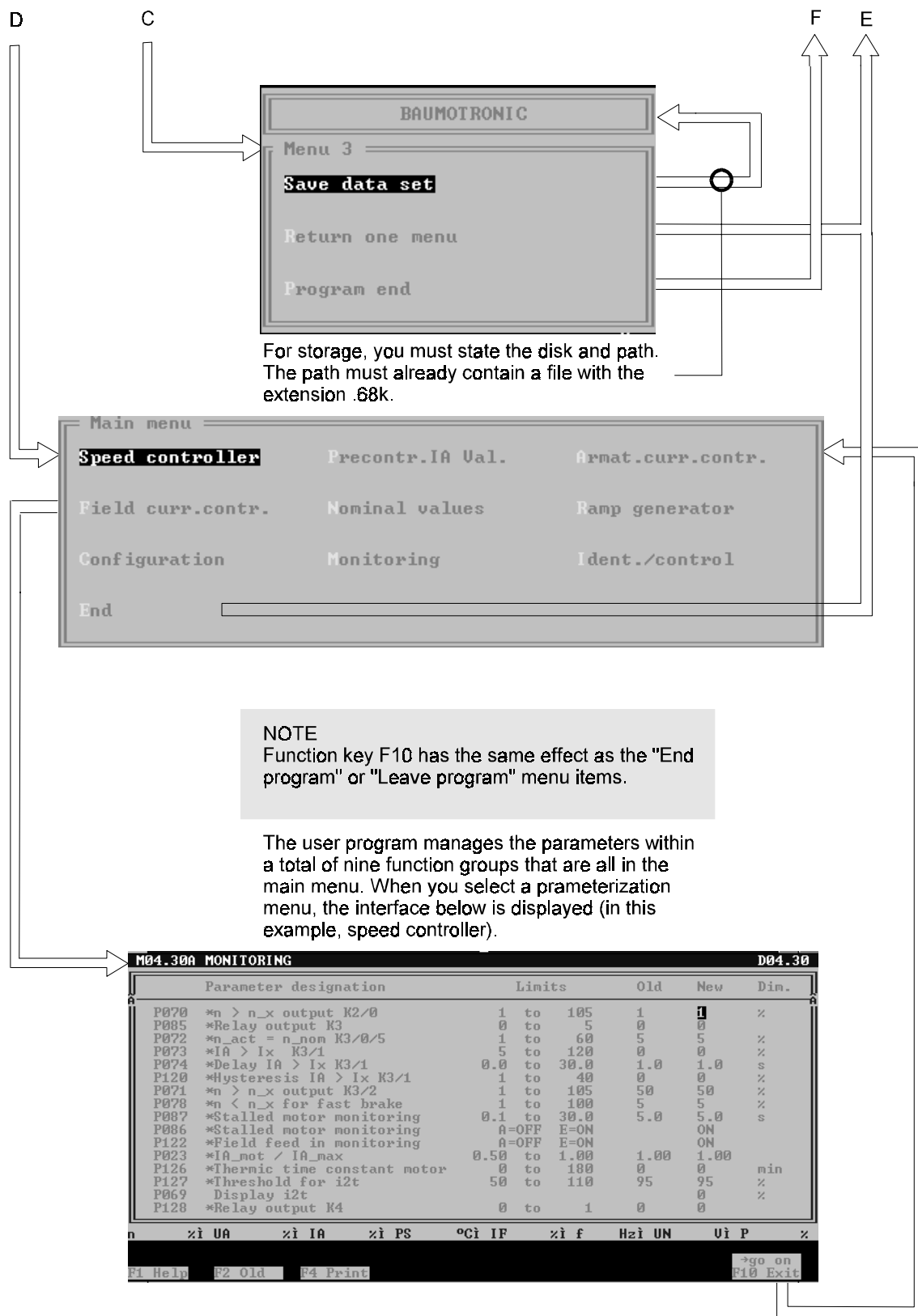

The parameter menus are divided into a header, a parameter area with an actual value bar and a footer:

• Header

M04.30A SPEED CONTROLLER **D04.30**

- M04.30: Software version of the user program
- Speed controller: Name of the menu
- D04.30 Software version of the standard data file on the floppy disk

• Parameter area

Parameter designation	Limits	Old	New	Dim.
P011 *P-amplification	1 to 100	10	10	
P012 *Integral-action time	20 to 9990	500	500	ms
P014 *Current limit TD1/Drive	0 to 100	100	100	%
P015 *Current limit TD2/Brake	0 to 100	100	100	%
P010 *n_act - smoothing	5 to 100	10	10	ms
P018 *Integral-action time	A=OFF E=ON		ON	
P019 *speed controller offset	-400 to +400	0	0	
P002 *Armature voltage adjustment	0.90 to 1.10	1.00	1.00	
P016 *Curr. limit reduction at n_x	0 to 100	100	100	%
P017 *Current limit at n_max	0 to 100	100	100	%
P022 *speed controller preset	-100 to +100	0	0	%
P021 *Current limit switching	1 to 2	1	1	
P118 Gear ratio	1 to 4			
P142 *Maximum speed value	100 to 6000	1000	1000	rpm
P143 *Rotary encoder resolution	250 to 4096	1024	1024	
P144 *Rot. enc. polarity change	A=OFF E=ON		OFF	

n %i UA %i IA %i PS °C i IF %i f Hz i UN U i P %

Parameter list: e.g. speed controller

Parameter: In the menu, parameters are sorted by their functions. Most of the parameters for which limits are not stated are displays that you cannot set.

Parameter designation: * These parameters are components of the data set
 + These are basic parameters that apply to all the data sets (P001, P006, P007, P009). The undesignated parameters' functions and displays can only be used in conjunction with the power converter.

Limits The value or range that can be set is stated. With many of the parameters, you can press the **F1** key to call a submenu which lists possible alternatives.

Column "old": Every time a parameter value is changed, the system writes the previous value to the Old column. Press the **F2** key to switch between the old value and the new one.

Column "new" Display of the current value.

Example:

You should prepare parameterization of a power converter in advance on paper such that you have available a functioning data set that can be transferred.

The user program (including the file D04xx.68k) is installed on the hard disk in the path C:\BKF12\.

Software version S04.30 is used with standard data set D04.30 serving as the basis of parameterization. The newly generated data set is to be stored on the hard disk and on floppy drive A: as data set XYZ.68k. In addition, we want to generate a listing of the data set.

The parameter values to be changed have already been established:

P021 (current limit switching in the speed controller menu) = 2, P171 (relay output K2 on page 2 of the monitoring menu) = 1.

- 1 Prepare a floppy disk:
Since this is a blank disk, you must first copy programs S0430_D.exe and S0430_E.exe and data file D0430.68k to it. To do this, you can use normal DOS commands.

Operator action

Response on the screen

- 2 Call the program:
C:\BKF12>S0430_D

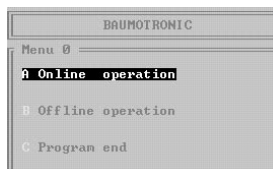

OFFLINE operation

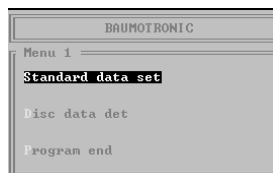

- 3 Choose a data set:
Default data set

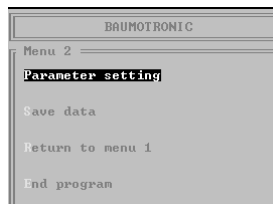

- 4 Parameterization



- 5 Change Parameter

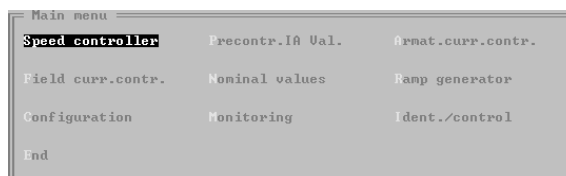

- 6 Choose speed controller with cursor P021

There are two options:

MB4.300 MONITORING		D04.30			
Parameter designation	Limits	Old	New	Dim.	
P070 *n > n_x output K2/0	1 to 105	1	1	%	
P085 *Relay output K3	0 to 5	0	0	%	
P072 *n_act = n_nom K3/0/5	1 to 60	5	5	%	
P073 *IA > Ix K3/1	5 to 120	0	0	%	
P074 *Delay IA > Ix K3/1	0.0 to 30.0	1.0	1.0	s	
P120 *Hysteresis IA > Ix K3/1	1 to 40	0	0	%	
P071 *n > n_x output K3/2	1 to 105	50	50	%	
P078 *n < n_x For fast brake	1 to 100	5	5	%	
P087 *Stalled motor monitoring	0.1 to 30.0	5.0	5.0	s	
P086 *Stalled motor monitoring	a=OFF E=ON	ON	ON		
P122 *Field feed in monitoring	a=OFF E=ON	ON	ON		
P023 *IA_not / IA_max	0.50 to 1.00	1.00	1.00		
P126 *Thermic time constant motor	0 to 100	0	0	min	
P127 *Threshold for i2t	50 to 110	95	95	%	
P069 Display i2t		0	0	%	
P120 *Relay output K4	0 to 1	0	0	%	

n xi UA xi IA xi PS °Ci IF xi f Hz UN Ui P x
 F1 Help F2 Old F4 Print F8 on F10 Exit

Operator action

Response on the screen

- 6.1 Press F1 for help
- Choose 2 with cursor
- Press Return

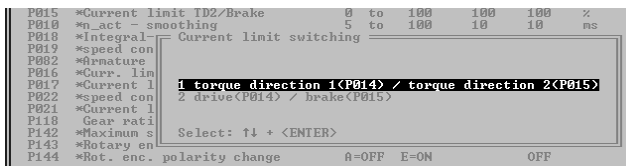

or

- 6.2 Enter 2
- Press Return

P021 Current limit switchover = 2

- 7 Go back to main menu:
- Press F10

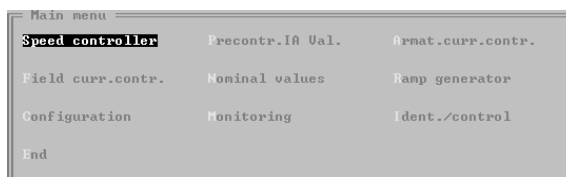

- 8 Monitoring

M04.30A MONITORING		D04.30		
Parameter designation	Limits	Old	New	Dim.
P070 *n > n_x output K2/0	1 to 105	1	1	%
P085 *Relay output K3	0 to 5	0	0	%
P072 *n_act = n_non K3/0/5	1 to 60	5	5	%
P073 *IA > Ix K3/1	5 to 120	0	0	%
P074 *Delay IA > Ix K3/1	0.0 to 30.0	1.0	1.0	s
P120 *Hysteresis IA > Ix K3/1	1 to 40	0	0	%
P071 *n > n_x output K3/2	1 to 105	50	50	%
P078 *n < n_x for fast brake	1 to 100	5	5	%
P087 *Stalled motor monitoring	0.1 to 30.0	5.0	5.0	s
P086 *Stalled motor monitoring	0=OFF E=ON	ON	ON	
P122 *Field feed in monitoring	0=OFF E=ON	ON	ON	
P023 *IA_mot / IA_max	0.50 to 1.00	1.00	1.00	
P126 *Thermic time constant motor	0 to 180	0	0	min
P127 *Threshold for I2t	50 to 110	95	95	%
P069 Display I2t		0	0	%
P128 *Relay output K4	0 to 1	0	0	%

- Choose 2nd page:
- Press right arrow key
- Choose P171
- Enter 1
- Press Return

M04.30A MONITORING		D04.30		
Parameter designation	Limits	Old	New	Dim.
P138 *Threshold tacho polarity	10 to 62	10	10	%
P140 *Threshold tacho wire break	5 to 65	20	20	%
P141 *Delay time armature open	1.0 to 10.0	1.0	1.0	s
P171 *Relay output K2	0 to 1	0	0	%
P172 *IA > Ix K2/1	5 to 120	95	95	%
P173 *Response time IA>Ix K2/1	0.0 to 30.0	0.0	0.0	s
P174 *Linking relay K2/1-K3/1	0=OFF E=ON	OFF	OFF	
P175 *Linking time K2/1-K3/1	0 to 900	60	60	s
P146 *Timeout firing pulses disable	0.1 to 2.0	0.2	0.2	s
P158 *Multiplier P070/P078	0 to 1	0	0	%
P157 *Release delay K2/0	0.0 to 30.0	0.0	0.0	s
P156 *mains failure timeout	0.0 to 6.0	0.0	0.0	s

- 9 Go back to main menu:
- Press left arrow key or F10

M04.30A MONITORING		D04.30		
Parameter designation	Limits	Old	New	Dim.
P070 *n > n_x output K2/0	1 to 105	1	1	%
P085 *Relay output K3	0 to 5	0	0	%
P072 *n_act = n_non K3/0/5	1 to 60	5	5	%
P073 *IA > Ix K3/1	5 to 120	0	0	%
P074 *Delay IA > Ix K3/1	0.0 to 30.0	1.0	1.0	s
P120 *Hysteresis IA > Ix K3/1	1 to 40	0	0	%
P071 *n > n_x output K3/2	1 to 105	50	50	%
P078 *n < n_x for fast brake	1 to 100	5	5	%
P087 *Stalled motor monitoring	0.1 to 30.0	5.0	5.0	s
P086 *Stalled motor monitoring	0=OFF E=ON	ON	ON	
P122 *Field feed in monitoring	0=OFF E=ON	ON	ON	
P023 *IA_mot / IA_max	0.50 to 1.00	1.00	1.00	
P126 *Thermic time constant motor	0 to 180	0	0	min
P127 *Threshold for I2t	50 to 110	95	95	%
P069 Display I2t		0	0	%
P128 *Relay output K4	0 to 1	0	0	%

Operator action

Response on the screen

Press F10 again

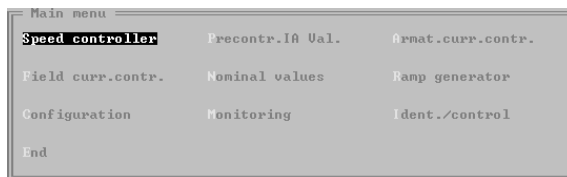

10

Preparing a listing

Choose any menu except "End" (e.g. speed controller)

Press F4

Comment: max. of 72 characters min. of 1 character otherwise program terminates!

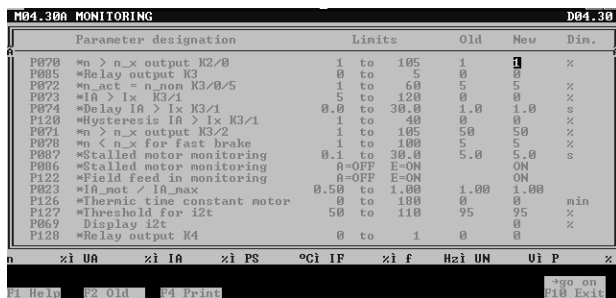

Press Return

NOTE

You can only issue the print command within the nine parameterization menus.

11

Save data

Keep pressing F10 until menu 2 is displayed

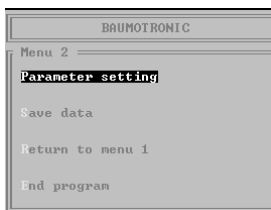

Save your data

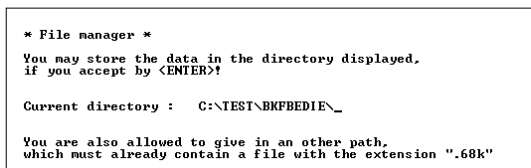

To save to hard disk

Press Return

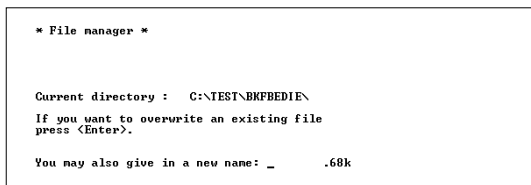

Enter XYZ

Press Return



Save your data
 Save on floppy disk
 Drive A:

```
* File manager *
You may store the data in the directory displayed,
if you accept by <ENTER>!

Current directory : C:\TEST\BKFBEDIE\_

You are also allowed to give in an other path,
which must already contain a file with the extension ".68k"
```

Enter A:
 Press Return

```
* File manager *
You may store the data in the directory displayed,
if you accept by <ENTER>!

Current directory : a:\_

You are also allowed to give in an other path,
which must already contain a file with the extension ".68k"
```

Press Return

```
* File manager *

Current directory : a:\
If you want to overwrite an existing file
press <Enter>.

You may also give in a new name: _ .68k
```

Enter XYZ
 Press Return

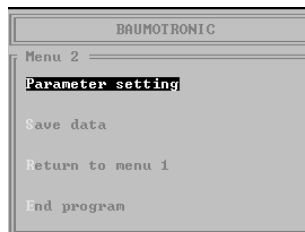

12 Exit the program:
 End program

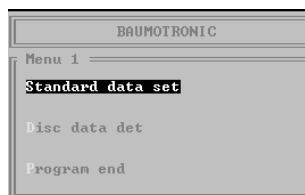

Exit the program

b) Online Operation

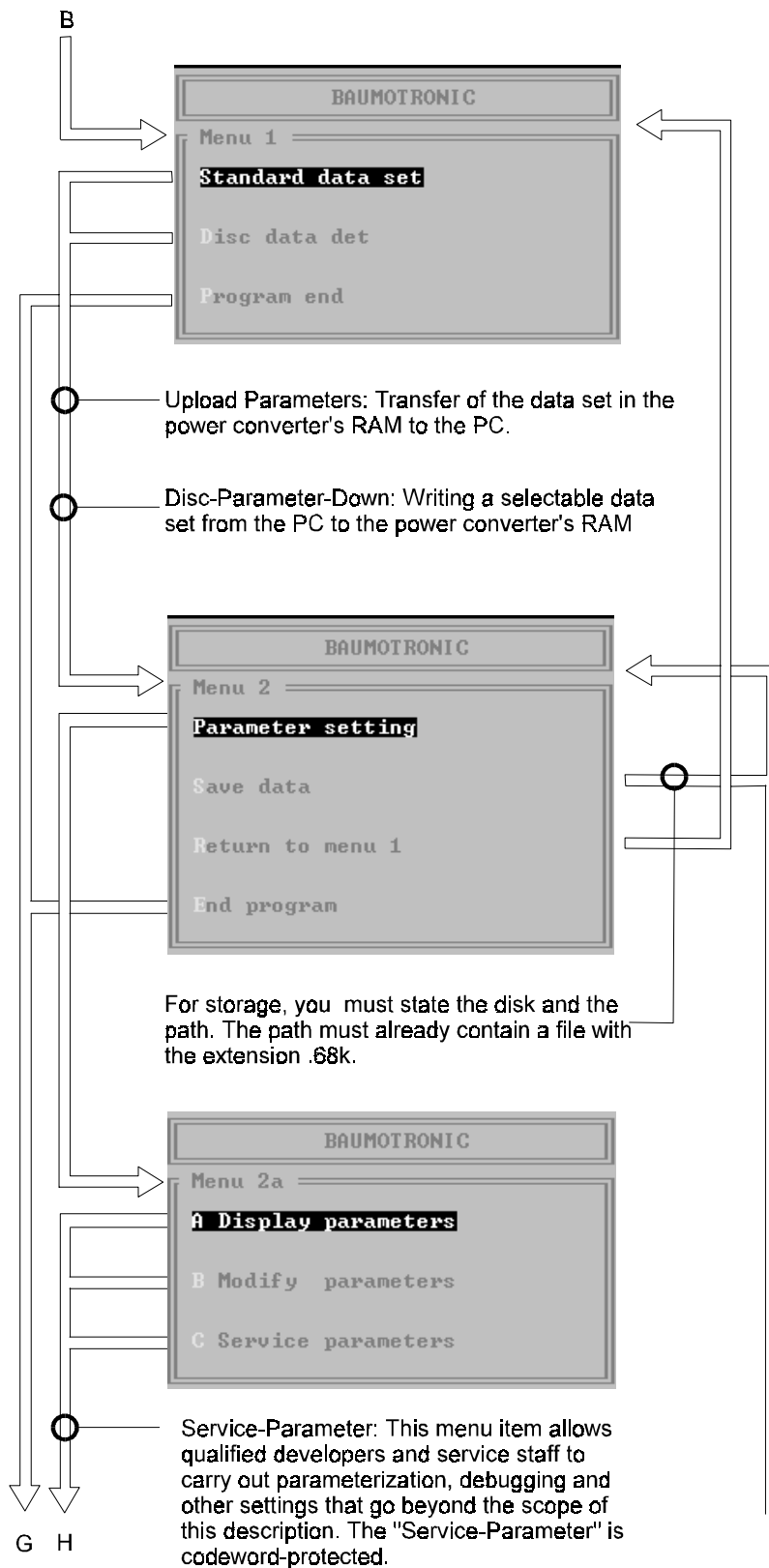

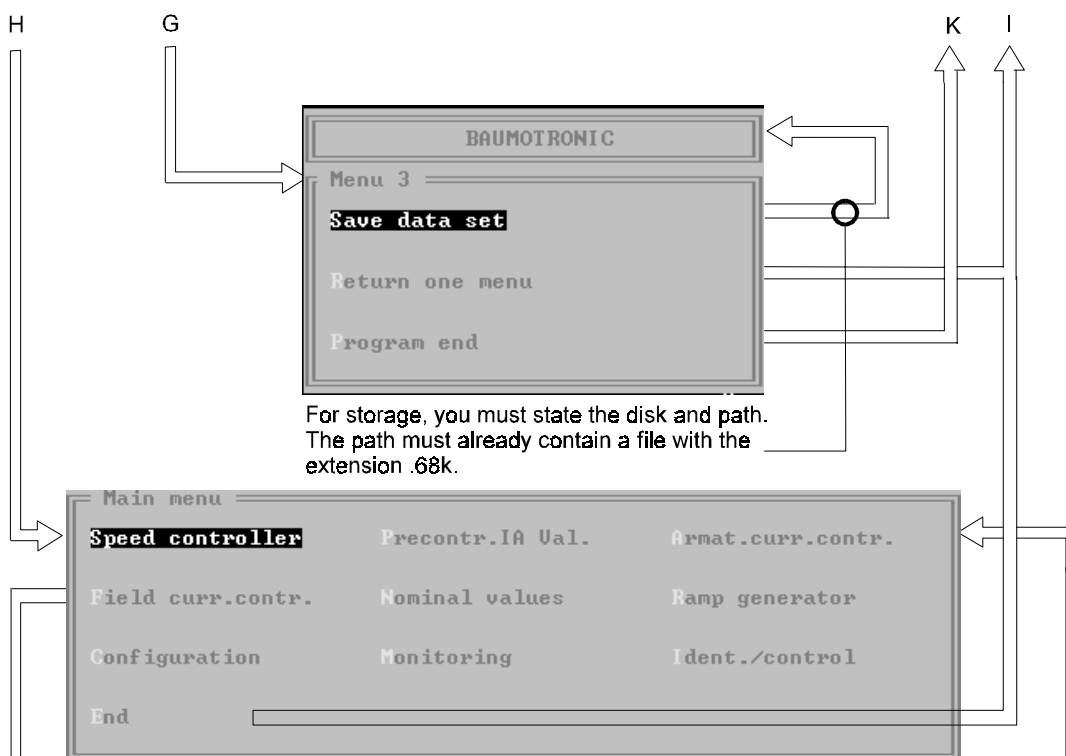

For storage, you must state the disk and path.
The path must already contain a file with the extension .68k.

In ONLINE operation, the system displays in the footer function keys F7 for controller enable, F8 for fast brake and F9 for main contactor OFF.
In ONLINE operation, you use the function keys to issue the power converter software enables. These are logically ANDed with the hardware enables at the unit's control inputs X1:22 ... 24.

M04.30A SPEED CONTROLLER		BKF12-6000		U04.30		150A/4.0A		D04.30	
Parameter designation	Limits	Old	New	Din.					
P011	*P-amplification	1 to 100	10	10					
P012	*Integral-action time	20 to 9990	500	500	ms				
P014	*Current limit ID1/Drive	0 to 100	100	100	%				
P015	*Current limit ID2/Brake	0 to 100	100	100	%				
P010	*n_act - smoothing	5 to 100	10	12	ms				
P018	*Integral-action time	A=OFF	E=ON	0N					
P019	*speed controller offset	-400 to +400	0	0					
P002	*armature voltage adjustment	0.90 to 1.10	1.00	1.00					
P016	*Curr. limit reduction at n_x	0 to 100	100	100	%				
P017	*Current limit at n_max	0 to 100	100	100	%				
P022	*speed controller preset	-100 to +100	0	0	%				
P021	*Current limit switching	1 to 2	1	1					
P118	Gear ratio	1 to 4	0	1					
P142	*Maximum speed value	100 to 6000	1000	1000	rpm				
P143	*Rotary encoder resolution	250 to 4096	1024	1024					
P144	*Rot. enc. polarity change	A=OFF	E=ON	OFF					

n 0 xi UA 0 xi IA 0 xi PS 23 °Ci IF --- xi f 50 Hzi UN 405 Ui P 0 x
 Drive Off Get message via F3
 F1 Help F2 Old F4 Print OFF OFF OFF
 F7 Enable F8 F_B F9 M_O M10 Exit

The parameter menus are divided into a header, a parameter area with an actual value bar and a footer:

- Header

M04.30A SPEED CONTROLLER BKF12-6000 U04.30 150A/4.0A D04.30

- M04.30: Software version of the user program
- Speed controller: Name of the parameterization menu
- BKF12 - 6000 Type of power converter
- V04.30 Software version of the power converter's user program
- 30 A/2.0 A Rated DC currents of the connected unit for the armature and field
- D04.30 Software version of the standard data file on the floppy disk

- Parameter range with actual value bar

Parameterliste: e.g. speed controller

Parameter designation	Limits	Old	New	Dim.
P011 *P-amplification	1 to 100	10	10	
P012 *Integral-action time	20 to 9990	500	500	ms
P014 *Current limit ID1/Drive	0 to 100	100	100	%
P015 *Current limit ID2/Brake	0 to 100	100	100	%
P010 *n_act - smoothing	5 to 100	10	10	ms
P018 *Integral-action time	A=OFF E=ON		ON	
P019 *speed controller offset	-400 to +400	0	0	
P002 *Armature voltage adjustment	0.90 to 1.10	1.00	1.00	
P016 *Curr. limit reduction at n_x	0 to 100	100	100	%
P017 *Current limit at n_max	0 to 100	100	100	%
P022 *speed controller preset	-100 to +100	0	0	%
P021 *Current limit switching	1 to 2	1	1	
P118 Gear ratio	1 to 4		0	
P142 *Maximum speed value	100 to 6000	1000	1000	rpm
P143 *Rotary encoder resolution	250 to 4096	1024	1024	
P144 *Rot. enc. polarity change	A=OFF E=ON		OFF	

- Parameterbezeichnung See offline operation
- Grenzen See offline operation
- Spalte "alt": See offline operation
- Spalte "neu": See offline operation
- Dimension: See offline operation

• Actual value bar:

n 0 % | U_A 0 % | I_A 0 % | L_T 29 °C | I_F 0 % | f 50 Hz | U_N 395 V | P 0 %

P060 Speed actual value	n	[% of n _{max}]
P061 Armature voltage actual value	U _A	[% of U _{anom}]
P062 Armature current actual value	I _A	[% of max. armature current]
P063 Temperature of power stage	L _T	[°C]
P064 Field current actual value	I _F	[% of rated field current]
P066 Mains frequency	f	[Hz]
P067 Mains voltage	U _n	[V _{eff}]
P068 Power consumption	P	[% of the max. power U _A *I _A]













• Footer:

Drive Off Get message via F3

F1 Help F2 Old F4 Print OFF OFF OFF

F7 Enable F8 F_B F9 M_O F10 Exit

Function keys:

-  Help: Makes parameterization easier and makes it unnecessary to keep looking in the manual. With many of the parameters, you can press the  key to call a submenu which lists possible alternative settings.
-  Old: Changes between the old parameter value and the new one
-  Error: As soon as an error occurs, the system displays "Fetch message F3". When you press , the error is displayed in plain text. Pressing  closes the error display.
-  Print: See offline operation
-  Enable: Logically ANDed with switching input X1:23 (controller enable)
-  F_B: Logically ANDed with switching input X1:24 (emergency stop)
-  M_O: Logically ANDed with switching input X1:22
-  Exit: This closes the menu and brings you back to the main menu!
-  next page:
-  previous page: With menus that have more than one page, e.g. the Precontr. IA Val menu, you press the appropriate arrow key to go to the next page or the previous page respectively.

Messages:

Drive OFF: Drive is disabled

Drive ON: Drive is enabled

Get message  Displayed in the event of an error

Example in 7.2.3 a) (continued)

You use the floppy disk, which now contains data sets D0430.68k and xyz.68k and program S0430_D.EXE and possibly S0430_E.EXE, to parameterize the drive on another PC that has a black and white monitor. Serial port COM2 is used.

Starting point: The power converter's mains unit is connected to a voltage and the communication source has already been set to P001 = 1 (PC operation).

Operator action

Response on the screen

1

Call the program:
A:\>S0430_D_bw_com2

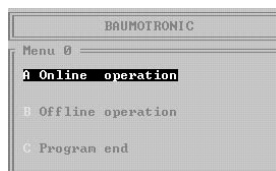

ONLINE operation

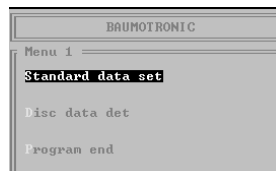

2

Disk-Parameter-Down

:

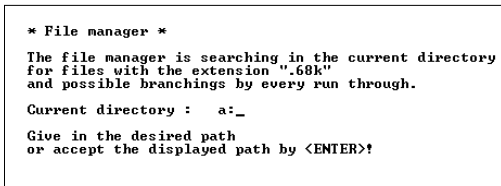

Press Return

Use the cursor keys to choose XYZ.68k

Press Return

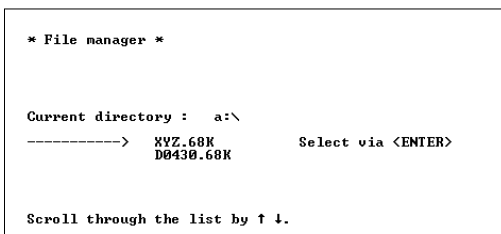

During the transfer, "Download" is displayed in the middle of the screen. At the bottom right, the message "Transfer active" flashes.

3 Two possibilities

3.1 Transfer functions with no problems

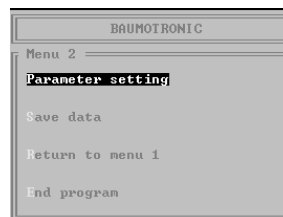

3.2 Problem parameters occur

If errors occur during downloading, the system displays them after transfer is completed:

Example:
User software S04.30 is being used with a unit with operation software S04.24.

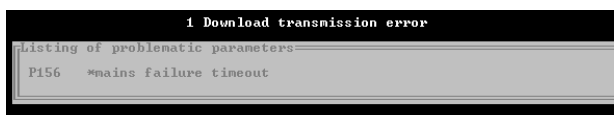

Cause:
P157 and P158 are not yet available in power converter software S04.24 so the system issues negative confirmation at downloading.

Acknowledge:

Press Return

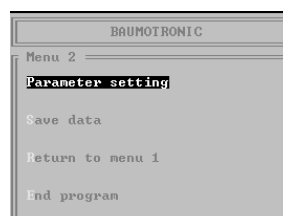

4 Parameterization:

For an explanation of further procedure, refer to "Commissioning Guidelines".

7.3 Commissioning Guidelines

7.3.1 Stock-Taking

Record the data of machines, the motor, the power converter and additional components and enter it in the configuration and commissioning log.

Note: A .. T: These values are needed at parameterization to calculate drive-specific values.

- Machine: Type, serial number, customer
- Mains connected load, frequency, type of mains (TN or TT system)
 - e.g.: voltage: 3 x 400 V A
 - rotating field: Clockwise rotating field B
- Power converter The rating plate is on the left-hand side inside the casing.
 - acc. to rating plate e.g.

Built in power converter for conversion and inversion

Type: BKF 12/050/400-60400000

Input: 3 AC 400 V 50 ... 60 Hz C

Output: DC 0 ... 400 V 50 A D, E

Mode: DB mains: TN or TT No. 90316556J

- Field supply acc. to rating plate The rating plate is below terminal strip X2 on PCB 3.8942.
 - e.g.: type: BKFN 400F 400R
 - E-No.: 90316556J
 - rated unit field current: 4A F
- Software version of processor board Printed on both EPROMs
 - e.g.: 8934.501 8934.502
 - H00.01 H00.02 ⇔ Version S04.30
 - S04.30 S04.30
- Daughterboard fitted for connection to a controller?
 - e.g.: type 3.8947.01A: RS232, RS 485
 - software version: 8947.002
 - H02.00 ⇔ Version S01.12
 - S01.12
- Tachometer resistance: R102: kΩ / 2W / TK 25 G
 - Position on processor board 3.8934
 - refer to: 6.2 Speed Control with Analog Tachometer
- Supply of switching inputs

	X1/22...29,42:	+24 V from unit	W11: fitted
			W13: A-B
	X1/22...29,42:	+24 V external	W11: not fitted
			W13: A-B
	X1/22...24,26...29,42:	+24 V external	W11: not fitted
	X1/25	+24 V from unit	W13: B-C
	See 5.2 Connection of Controller Modules BKD and BKF		

- Motor data e.g.:
according to rating plate:

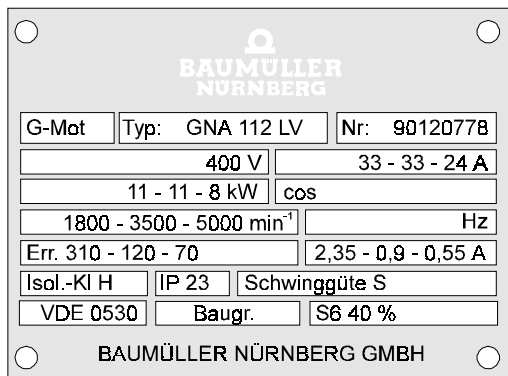

Meaning:

DC Motor		Type	GNA	112 LV	Serial No. 90120778	
Armature Voltage	U_A	0	400 V	400 V	400 V	
Armature Current	I_A	33 A	33 A	33 A	24 A	
Power	P	0	11 kW	11 kW	8 kW	
Speed	n	0	1800 RPM	3500 RPM	5000 RPM	
Field Voltage	U_F	310 V	310 V	120 V	70 V	
Field Current	I_F	2.35 A	2.35 A	0.9 A	0.55 A	
			Armature Adjusting Range		Field Adjusting Range	
			Constant Torque		At constant power	At the commutation limit

H

K

I

L

N

M

O

P

Rated values at basic speed
Operating mode S6 40% according to VDE 0530

- Tachometer generator e.g.: Type: GHTS42
No.: 003319
Current: max. of 10 mA
Voltage: 20 V/1000 RPM
- Incremental encoder e.g.: Type
No. of pulses: 1024 pulses/rev.
Max. speed: RPM
Supply voltage: V
- Three-phase line reactor for the armature power converter
- Single-phase line reactor for the field power converter
- Semiconductor fuses

Q

R

S

T

7.3.2 Parameterization

At commissioning of the power converter using the unit's keypad, it is advisable to first enter in the parameter documentation (sections 7.4 and 7.5) the parameters below that have to be established. You can then input the values when you actually program the unit.

NOTE

The customer must carry out documentation and administration of user-specific parameter sets.

- Specification of motor-specific parameter values

P105 Nominal mains voltage	e.g.: 400 V	
P110 Armature/mains voltage		
$P110 = \frac{\text{Armature voltage}}{\text{Nominal mains voltage}}$	e.g.: $\frac{400 \text{ V}}{400 \text{ V}} = 1$,
P025 $I_{A_{max}}$ /device nom. current	(see chapter 6.4.1)	
$P025 = \frac{\text{Max. armature current of motor}}{\text{Unit's nominal current}}$	e.g.: $\frac{33 \text{ A}}{50 \text{ A}} = 0.66$,
P016 Current limit reduction at n_x	(see chapter 6.4.1)	
P017 Only with motors that are run in the high speed range at the commutation limit curve		
$P016 = \frac{\text{Application speed}}{\text{Max. motor speed}}$	e.g.: $\frac{3500 \text{ RPM}}{5000 \text{ RPM}} * 100\% = 70 \%$,
$P017 = \frac{\text{Motor current at } n_{max}}{\text{Max. armature current of motor}}$	e.g.: $\frac{24 \text{ A}}{33 \text{ A}} * 100\% = 72 \%$,
P049 $I_{F_{max}}$ /device nom. current	(see chapter 6.4.2)	
$P049 = \frac{\text{Nominal motor field current}}{\text{Nominal field device current}}$	e.g.: $\frac{2.35 \text{ A}}{4.0 \text{ A}} = 0.59$,

P083: Controller structure
(see chapter 6.2)

Control by means of tachometer generator or incremental encoder (constant field ⇔ field weakening), e.m.f. control or current control?

Value	Meaning
0	Tachometer generator, constant field Tachometer adaptation R102, fine matching R103
1	Tachometer generator, field weakening additional parameters to be set P047: Minimal field current $P047 = \frac{\text{Min. field current}}{\text{Max. field current}} \cdot 80\% \quad \text{e.g.: } \frac{0.55 \text{ A}}{2.35 \text{ A}} \cdot 80 \% = 20 \%$ P042: Cross-over/arma. voltage Default value: 0.95· rated armature voltage P145: Field weakening mode
2	Rotary encoder, constant field additional parameters to be set P142: Rated speed of motor e.g.: 5000 RPM P143: Rotary encoder resolution e.g.: 1024 incr./rev. P144: Rotary encoder polarity change
3	Rotary encoder, field weakening see P083 = 1, 2
4	e.m.f. control with constant field speed adaptation using P082 and P110
5	Current control with constant field

O, P

H

L

R

– Specifying the drive-specific parameter values

- Specified value source (see chapter 6.3)
P080 = 0 ... 16

List of the parameters that are assigned to individual specified value sources

Value	Meaning
1	Analog 1 (differential amplifier) Analog adaptation: potentiometer R100 ($v = 0.9 \dots 2.0$)
2	Analog 2 (summing amplifier) Digital adaptation: P113, P114
3	Analog 1 + 2; P113, P114
4	Digital (serial) Setting via P050 when P001 = 1, 2, 3
5	Internal specified value generator For value, see P090 ... P093
6	Internal specified value 1 For value, see P051
7	Internal specified value 2 For value, see P052
8	Internal specified value 3 For value, see P053
9	Internal specified value 4 For value, see P054
10	Motorized potentiometer For value, see P055 ... P058
11 (S04.11 and above)	Specified value setting via DPRAM no protocol 16-bit. Can only be used in conjunction with InterBus-S daughterboard PCB 3.9208.
12 (S04.11 and above)	Parallel specified value setting 15-bit twos complement. Permissible value range.: \$3FF0 to \$4010. PCB 3.9217 needed.
13 (S04.11 and above)	Parallel specified value setting 14-bit and sign. Permissible value range: \$0 to \$3FF0. If bit no. 15 = 1, the value is interpreted as a negative number (amount + sign). PCB 3.9217 needed.
14 (S04.11 and above)	Parallel specified value setting 12-bit and sign. Decimal specified value setting (amount + sign). Permissible value range: 0 to 999 (percentual setting). If bit no. 15 = 1, the value is interpreted as a negative number. If a code is entered in on of the three places that is not a decimal number, the system does not accept the specified value. PCB 3.9217 needed.
15 (S04.28 and above)	Sum of specified value sources 2 and 4 P113, P114, P001
16 (S04.15 and above)	Analog specified value via differential amplifier and analog additional specified value via summing amplifier. Has a similar effect to P080 = 3, however the specified value from the differential amplifier is routed directly to the speed controller and the specified value from the summing amplifier is transferred to the speed controller via the ramp function generator. P149 does not affect P080 = 16, P113, P114, P094, P095, P096 or P100, P101, P102

- Ramp function generator (see chapter 6.3)
 - Ramp function generator 1: P094: ON/OFF
 - P095: RG1 Acceleration time
 - P096: RG1 Deceleration time
 - Ramp function generator 2: P100: ON/OFF
 - P101: RG2 Acceleration time
 - P102: RG2 Deceleration time
- S-ramp generator (see chapter 6.3)
 - P097: time constant
 - P098: ON/OFF
- Enabling the power converter and main contactor control (see chapters 6.7.1, 6.7.3)

Affected parameters:

 - P001: Communication source
 - P124: Drive inhibit function
 - P146: Timeout firing pulses disable
(leave at default setting)
 - P123: Fast brake
 - P079: Main contactor edge
 - P078: $n < n_x$ for fast brake

When commissioning using a PC (P001 = 1), it is advisable to initially set P124 = 1 and P079 = OFF and to leave the hardware enables permanently pending. In this way, the drive can be controlled by means of the three software enables that are activated using the function keys.
- Current limitation (see chapter 6.4)
 - P014: Current limit TD1/Drive
 - P015: Current limit TD2/Brake
 - P021: Current limit switching

It is advisable to leave P014 and P015 at the default value of 100% until optimization run P081 = 1 has been carried out at equipment setting.

If you set the current limit too low, it may not be possible to specify the characteristic curve parameters. At the optimization run, this results in error message F102 or F103.

 - Gear protection P027: current
P028: time
- Programmable input X1:9 (see chapter 6.7.2)
 - P084: 0 ... 13
- Inputs X1:28 and X1:29 (see chapter 6.7.2)
 - P099: 0 ... 4
- Analog output to measuring channels 1 ... 4 (see chapter 6.6)

Measuring channels 3 and 4 are only available with daughterboards 3.9201/3.9217.

 - P088, P089, P125
 - P130, P131, P132

- Monitoring

(see chapter 6.5)

- P171: Relay output K2
affected parameters:
P070, P158, P157, P172, P173, P174, P175
- P085: Relay output K3
affected parameters:
P072, P073, P074, P120, P071, P174, P175
- P128: Relay output K4
affected parameters:
P126, P023, P127
- P122: Field feed in monitoring
P086,
- P087: Stalled motor monitoring
- P138: Threshold tacho polarity
- P140: Threshold tacho wire break
- P141: Delay time armature open
- P117: Pull-in time I_F monitoring

- Other special parameters

- P147: Phase failure < 400 msec
- P156: Mains failure timeout
- P007: Counterclockwise rotating field inhibit
Set to ON! Operation with counterclockwise rotating field in exceptional cases only
- P148: Load data set
- P075: Reduced field
P076: Time for reduced field
P077: I_{F_nom} for reduced field
- P039: Field unit ON/OFF
- P118: Gear stage
The system transfers the values for the speed controller protective circuit (P011 and P012) to the active data set from the data set specified by means of P118. All the other setting values stay the same. Switchover is only possible by means of the available interface boards or the PC.
- P149: Nominal value multiplier see P084 = 4
- P115, See parameter list
- P116: $n_{nom} = 0$ lock/threshold

- Controller parameters

Field current controller (I_F controller)

- P043: P-amplification
 P044: Integr. act. time (I_F contr.)

Armature voltage controller (U_A controller)

Is only in effect with controller structures (P083) with field weakening control

- P040: P-amplification
 P041: Integr. act. time (U_A controller)

Armature current controller (I_A controller)

- P030: I_{anom} integrator
 P031: P-amplification
 P032: Integral-action time
 P033: Integ. act. time (I_A gapping)
 P034: Gapping current adaption ON
 P035: Integral-action time ON
 P038: Source I_A precontrolling

Speed controller

- P011: P-amplification
 P012: Integral-action time
 P010: n_{act} - smoothing
 P018: Integral-action time ON/OFF

Setting controller parameters:

Experience has shown that, with most applications, you can use the default values for the field current, armature voltage and current controllers regardless of the motor size.

With special applications or third-party motors, it may be necessary to carry out reoptimization (refer to Equipment Set-up below).

You must adapt the speed controller to the drive- and system-specific conditions (e.g. the motor moment of inertia, the drive torque, special requirements).

Empirical values:

- Controller structure P083 = 0 ... 3 (n-controller with analog tachometer or rotary encoder)

- Motors with rated speeds ≥ 2000 RPM

- P011: ≥ 10
 P012: 200 ... 500 ms
 P010: 10 ms

- Slow-running motors (rated speed approx. 1000 RPM)

- P011: 5 ... 10
 P012: 200 ... 500 ms
 P010: 10 ms

- Controller structure P083 = 4 (e.m.f. control)

- P011: 8
 P012: 500 ms
 P010: 20 ms

7.3.3 Equipment Set-Up

Before switching on

1. General checks

- Check the cabling and cable cross-sections
- Check the equipment connections and protective measures



WARNING

During operation, the power stage and the mains and motor connections are live!

- Check higher-level safety equipment (e.g. Emergency Stop on the machine).

2. Adapting speed measurement (option of 2.1 or 2.2)

2.1 Speed control with analog tachometer

- Fit the correct tachometer series resistor R102 (see 6.2 Specifying the Controller Structure).
- Set potentiometer R103 (fine-tuning the maximum speed) all the way anticlockwise to the lowest value.

2.2 Speed control with actual value rotary encoder

- Check the encoder connection on the supplementary module (see 2.8 Technical Data of Supplementary Modules as well as 5.3 Connection Plans and the detailed descriptions of supplementary modules)

a) Input/Output Expansion, 3.9217

Version 3.9217.01

Rotary encoder input with 5-V supply for two 90° phase-shifted differential pulses:

Plug: X7A

Jumpers W1, W2 B-C

Rotary encoder input with +24-V supply for two 90° phase-shifted differential pulses:

Plug: X7B: 15 - 17

Jumpers W1, W2 A-B

b) InterBus-S Interface Board, 3.9208

Version 3.9208.02

Rotary encoder input with 5-V supply for two 90° phase-shifted differential pulses:

Plug: X8D

c) RS485 Interface Board for CS31 System Bus or with USS protocol, 3.9493

Version 3.9493.02, 3.9493.04

Rotary encoder input with 5-V supply for two 90° phase-shifted differential pulses:

Plug: X8, X9

3. Adaptation of the voltage supply for inputs X1:22-29, 42:
See 5.3.1 Connecting Controller Module Sizes I ... IV
 - Jumpers W11, W13 fitted according to requirements

4. Triggering:
 - Controller and main contactor not yet enabled:

Main contactor ON	= OFF	⇔	X1:22	= 0 V
Controller enable	= OFF	⇔	X1:23	= 0 V
Cancel fast brake	= OFF	⇔	X1:24	= 0 V
 - Pulse enable = OFF ⇔ X1:25 = 0 V

As a result, the field current = 0 A while no data set is applied and the motor's rated field current has not yet been specified with P049. This is to protect the field winding

 - If several data sets are to be programmed only (P099 = 4):
interrupt X1:28,29.
This prevents uncontrolled switchover of data sets during parameterization and provides protection from parameterization errors.

Working with the unit switched-on

5. Mains connection:
 - Switch on the power converter: connect to the mains at the same time the mains unit, the field supply, the fan (with unit sizes II and above) and the motor fan
The following are carried out:
 - a lamp test
 - initialization
 - booting, i.e. transferring a data set (1 ... 4) from the EEPROM to RAM. At initial commissioning, data set 0 (the default data set) is booted from the EPROM.
 - Check the directions of rotation of the fans of the equipment and the motor
 - Operating displays:

LED messages: - H18/green (torque direction 1) or
H17/yellow (torque direction 2)

- H19/yellow (speed = 0)

- H21/red (controller disable)

- H22/red (message)

Messages on the display:

P159	= 24	⇔	Field current out of lower range
P159	= 61	⇔	No data set programmed
Possibly P159	= 45	⇔	Field connection not correct (field unit was switched on too late).

6. Default settings for operation at commissioning:
 - Keypad enabled
Use the keypad to set P104 = 17 (see 7.2.2)
After transfer, the value 17 is not displayed!
 - When carrying out commissioning with a PC: change the communication source to P001 = 1
(The factory default setting is P001 = 0 ⇔ keypad on power converter)

7. Basic settings at initial commissioning

- Generate a data set:
Program the EEPROM data set P004 = 1 ... 4
- Specify the boot source
Setting to the data set stored with P004 = 1 ... 4
⇒ Error message P159 = 61 ⇔ "No data set programmed" goes out.

8. Parameterization (choice of 8.1 or 8.2)

8.1 Parameterization manually or on the power converter's keypad

- See 7.2.2, Keypad and Display on the Power Converter
- Transfer of parameter values according to the parameter list in numerical order



8.2 Parameterization on a PC with user software

- See 7.2.3, Operation using a PC
Choice of:
 - Downloading preset parameter values
 - Parameterizing online directly at the drive

9. After completing parameterization

- Program the EEPROM: P004: 1 .. 4
Store the changed values in the EEPROM

10. Clear error P159 = 24

- Pulse enable = ON ⇔ X1:25 = 24 V
- Choice of:
 - With keypad operation (P001 = 0):
Choose P005: (read single error), after this press the mode key and then one of the counter keys
LED H22/red (message) goes out.
 - With PC operation (P001 = 1):
Press the F3 key: The error is displayed on the screen.
Press F10 to acknowledge the error.
LED H22/red (message) goes out.
 - Trigger a reset on the power converter.
Switch on the display by keeping the  or  key pressed for at least 1 second.
(In the case of parameterization by means of the keypad, you must then reenble the keypad with P104 = 17.)
 - Switch the mains unit briefly off and then on again (motor protective switch in the mains lead)

11. Characteristic curve optimization

- Block the motor
- Enter P081 = 1
- Enable the controller:

– Main contactor ON	= ON	↔	X1:22 = +24 V
– Controller enable	= ON	↔	X1:23 = +24 V
– Cancel fast brake	= ON	↔	X1:24 = +24 V

NOTE

With P081 = 1, 2 or 4 and drive ON, the system switches off the field internally and tests the armature circuit with current pulses. After optimization, the unit switches automatically to drive OFF.

If P014 and P015 are set too low, it may not be possible to determine some characteristic curve parameters. In this case, error message P159 = 102, 103 is issued. In this instance, you must set P014 and P015 to 100% for the duration of the optimization run.

Program the EEPROM: P004 = 1 ... 4

Store the changed values in the EEPROM

12. Check the nominal value setting

- Disable the controller
- Specify 100% nominal value
- On the power converter's display, set parameter P050 and check the specified value, see 6.3 Nominal Value Setting.

13. Speed setting, see 6.2 Specifying the Controller Structure

Procedure:

- Specify 10% nominal value (percentual display via P050)
- Enable the controller
- Using LED H17 for torque direction 1, check that the motor is running true and that the speed controller is optimized; use LED H18 to do the same for torque direction 2:
If both LEDs flicker, this may indicate controller oscillation; if necessary, reduce the P-amplification (P011) and increase the integral-action time (P012).
- Use a hand tachometer to measure and match the motor speed (see 13.1, 13.2, 13.3).
- Increase the speed step-by-step to the maximum level and adjust it if necessary
- At maximum speed, check the armature voltage (P061). This is particularly important for drives with field weakening.

In the case of drives with controller structure P083 = 0 and 2, reduce P049, "I_F max./device nom. current" if necessary; with drives with controller structure P083 = 1 and 3 reduce P047 "Minimal field current".

13.1 Speed setting with tachometer control

Potentiometer R103

13.2 Speed setting with rotary encoder control

Parameter P142 "Maximum speed value"

13.3 Speed setting with e.m.f. control

Parameter P082: "Armature voltage adjustment"

Parameter P110 "Armature/mains voltage"

14. Offset compensation
Set nominal value = 0 and compensate the offset with P019. You can also use P019 to balance the speeds with counterclockwise/clockwise running.
 15. Speed controller optimization
 - Set empirical values or carry out optimization according to generally applicable optimization criteria
 - Preset n-controller P022
This leads to jerk-free starting at controller enable on motors that carry torque when idling (e.g. lifting equipment). Positive values of P022 result, at controller enable, in clockwise counter-torque, with negative values having the opposite result.
You must determine the size of the counter-torques by trial and error.
 16. Check the ramp function generator and the S-ramp generator
see 6.3 Nominal Value Setting
 - Program the EEPROM: P004 = 1 .. 4
Store the changed values in the EEPROM
 17. Check the monitoring
 - Check relay functions K1 .. K4
For display parameter P107: Display of relay controls, refer to list of parameters
 18. Postoptimization of the current controller and the field current controller; only carry out postoptimization of the armature voltage controller at P083 = 1, 3
 - Set empirical values or carry out optimization according to generally applicable optimization criteria
 - Program the EEPROM: P004 = 1 .. 4
Store the changed values in the EEPROM
 19. Programming further data sets
If necessary
 - Repeat points 7. to 18.
- NOTE:**

Point 7: The boot source that was initially saved does not need to be changed!

Point 10: Not applicable

Point 11: You only need to carry out characteristic curve optimization again if parameter value P025 "I_F max./device nom. current" has changed in the newly created data set.
20. Set correctly any parameters that you assigned with different values during commissioning to make handling of the power converter easier.
If necessary
Possible parameters: P014, P015, P079, P080, P124, etc.

21. If several data sets were programmed only (P099 = 4)
 - Reconnect X1: 28 , 29
 - Check data set switchover by the external controller using display parameter P129 "Display loaded/programmed data set" on the power converter's display.

22. Change the communication source
If necessary

NOTE

Before changing from P001 = 1 (PC operation) to P001 = 0 (keypad operation), you must first unlock the keypad on the unit (P104 = 17)!

7.4 Configuration and Commissioning Record

		Changes:	By/Date
Machine	Type:
	Factory number:
	Client:
Mains	Voltage/Tolerance:
	Rotating field:
Power converter	Type:
	Serial number:
	Input: voltage:
	Output: voltage: current:
	Field: current:
	Software version:
	Interface board:
	R102:kΩ/2 W/TK25 W11: W13: A B C
DC motor	Type:
	No.:
	Armature voltage:
	Armature current:
	Power:
	RPM speed:
	Field voltage:
	Field current:
Speed measurement	Tachom. gen. Type:
	Voltage:
	Rotary encoder Type:
	Number of pulses:
3-phase current reactor	Type:
Single-phase line reactor	Type:
Semiconductor fuse	Phase fuses:
	Armature circuit fuses:
	Field fuses:

7.5 Parameter Documentation

No.	Name	Range	Value in Data set 0 (SV 04.30)	Value in Data set 1	Value in Data set 2	Value in Data set 3	Value in Data set 4
P000	Power stage	30 A ... > 600 A	Display				
P001 +	Communication source	0.0 ... 3.3	0				
P002	Rotating field	u: not specified rdf: clockwise ldf: counterclockwise	Display				
P003	Software version	04.xx	Display				
P004	Program EEPROM data set X	1 ... 4	0				
P005	Read single error	000 ... 115	See error list				
P006 +	Boot source	0 ... 4	0				
P007 +	Left rotary field lock	ON or OFF	ON				
P008	Load data set X	0 = EPROM Standard 1 = EEPROM data set 1 1 = EEPROM data set 2 1 = EEPROM data set 3 1 = EEPROM data set 4	0				
P009 +	Start parameter	0 ... 175	1				
P010 *	n_act smoothing	5 ... 100 ms	10				
P011 *	P-amplification	1 ... 100	10				
P012 *	Integral-action time	20 ms ... 9.99 s	500				
P013	Reserved						
P014 *	Current limit TD1	0 ... 100%	100				
P015 *	Current limit TD2	0 ... 100%	100				
P016 *	Curr. limit reduction at n _x	0 ... 100%	100				
P017 *	Current limit at n _{max}	0 ... 100%	100				
P018 *	Integral-action time	ON/OFF	ON				
P019 *	Speed controller offset	-400 ... +400 (-2.4 ... +2.4 %)	0				
P020 *	I x R	0.0 ... 50%	4.5				
P021 *	Current limit switching	1, 2	1				
P022 *	Speed controller preset	-100.0 ... 100.0%	0.0				

No.	Name	Range	Value in Data set 0 (SV 04.30)	Value in Data set 1	Value in Data set 2	Value in Data set 3	Value in Data set 4
P023 *	IA _{mot} /IA _{max}	Motor I _t monitoring in operation at overstress Setting range 0.50 ... 1.00	1.00				
P024 *	Gapping current limit	1 ... 100%	30				
P025 *	IA _{max} /device nom. current	0.50 ... 1.00	1.00				
P026 *	IA _{nom} idle time	0, 1, 2	1				
P027 *	Gear protection current	0 ... 100%	100				
P028 *	Gear protection time	0 ... 500 ms	0				
P029 *	Armature inductivity	0.0 ... 150.0	10.0				
P030 *	IA _{nom} integrator	0 ... 100 ms	6				
P031 *	P-amplification	0.05 ... 0.80	0.12				
P032 *	Integral-action time	5 ... 100 ms	32				
P033 *	Integral-action time (IA-gapping)	0.2 ... 100ms	8				
P034 *	Gapping current adaption	ON/OFF	ON				
P035 *	Integral-action time	ON/OFF	ON				
P036 *	Current precontrolling	ON/OFF	ON				
P037 *	Scaling IA precontrol	0.00 ... 1.00	1.00				
P038 *	Source IA precontrolling	1 or 2	1				
P039 *	Field device	ON/OFF	ON				
P040 *	P-amplific. UA controller	0.1 .. 20.0	1.5				
P041 *	Integ.-act. time UA controller	20 ... 999 ms	180				
P042 *	Cross-over/nom. arma. voltage	0.50 ... 1.00	0.95				
P043 *	P-amplific. IF controller	0.1 ... 20 .0	1.0				
P044 *	Integ.-act. time IF controller	20 ... 999 ms	180				
P045	Reserved						

No.	Name	Range	Value in Data set 0 (SV 04.30)	Value in Data set 1	Value in Data set 2	Value in Data set 3	Value in Data set 4
P046	Field current nominal value	... 100%	Display				
P047 *	Minimal field current	20 ... 99 %	90				
P048 *	Field current monitoring	... %	Display				
P049 *	IF _{max} /device nom. current	0.20 ... 1.00	1.00				
P050	Speed nominal value	-100.0 ... +100.0%	Display				
P051 *	Internal nominal value 1	-100.0 ... +100.0%	10.0				
P052 *	Internal nominal value 2	-100.0 ... +100.0%	-10.0				
P053 *	Internal nominal value 3	-100.0 ... +100.0%	5.0				
P054 *	Internal nominal value 4	-100.0 ... +100.0%	-5.0				
P055 *	Motorized pot. upper limit	-99.9 ... +100.0	100.0				
P056 *	Motorized pot. lower limit	-100.0 ... +99.9	0.0				
P057 *	Motorized pot. accel. time	0.1 ... 100.0 s	5				
P058 *	Motorized pot. decel. time	0.1 ... 100.0 s	5				
P059 +	Motor pot. memory value	0 ... ± 100%					
P060	Speed actual value	... %	Display				
P061	Armature voltage actual value	... %	Display				
P062	Armature current actual value	... %	Display				
P063	Temperature of power stage	... °C	Display				
P064	Field current actual value	... %	Display				
P065	Reserved						
P066	Mains frequency	... Hz	Display				
P067	Mains voltage	... V _{eff}	Display				
P068	Consumed power	... %	Display				
P069	I ² t value	... %	Display				
P070 *	n > n _x output K2/0	1 ... 105 %	1				
P071 *	n > n _x output K3/2	1 ... 105 %	50				
P072 *	n _{act} = n _{nom} for K3/0/5	1 ... 60%	5				

No.	Name	Range	Value in Data set 0 (SV 04.30)	Value in Data set 1	Value in Data set 2	Value in Data set 3	Value in Data set 4
P073 *	$I_A > I_x$ K3/1	5 ... 120%	95				
P074 *	Delay $I_A > I_x$ K3/1	0.0 ... 30.0 s	1.0				
P075 *	Reduced field	ON/OFF	OFF				
P076 *	Time for reduced field	0 ... 180 s	30				
P077 *	$I_{F_{nom}}$ reduced field	20 ... 100%	30				
P078 *	$n < n_x$ for fast brake	1 ... 100%	5				
P079 *	Main contactor edge	ON/OFF	ON				
P080 *	Nominal value source	1 ... 16	1				
P081	Optimization run	0, 1, 2, 4 or 6					
P082 *	Armature voltage adjustment	0.90 ... 1.10	1.0				
P083 *	Controller structure	0 ... 5	4				
P084 *	Programmable input X1:9	0 ... 11	0				
P085 *	Relay output K3	0 ... 5	0				
P086 *	Stalled motor monitoring	ON/OFF	ON				
P087 *	Stalled motor monitoring	0.1 ... 30 s	5.0 s				
P088 *	Analog output channel 1	0 ... ± 10 V	2				
P089 *	Analog output channel 2	0 ... ± 10 V	3				

1 Speed nominal value
 2 Ramp function generator output
 3 Nominal value on n-controller
 4 Speed actual value
 5 Armature voltage
 6 EMF
 7 n-controller output
 8 Amount n-controller output
 9 Amount I_{act}
 10 I-controller output
 11 Power
 12 Field current nominal value
 13 Field current nominal value
 14 I_f controller output
 15 Inverter input
 16 Inverter output
 17 n-controller P component
 18 n-controller I component
 19 Torque signalling

No.	Name	Range	Value in Data set 0 (SV 04.30)	Value in Data set 1	Value in Data set 2	Value in Data set 3	Value in Data set 4
P088 *	Continued	20 ZIL (second pulse suppr.)					
P089		21 Ripple limit					
		22 Ripple characteristic					
		23 e.m.f. compensation					
		24 IxR					
		25 U-α					
		26 Queue					
		27 I controller P component					
		28 I controller I component					
		29 I _r controller P component					
		30 I _r controller I component					
		31 Field U _A controller P comp.					
		32 Field U _A controller I comp.					
		33 Controller enable/disable					
		34 Current limit					
		35 Amount n _{act}					
		36 I _{Aact}					
		37 I ² t value					
		38 Drive/brake					
		39 Polarity n _{act}					
		40 Load torque					
		41 Permissible nominal value					
		42 Field curr. monit. thresh.					
		43 Inverted to 19					
		44 Current reserve					
		45 Inverted to 199					
		46 Inverted to 1936					
		47 Mains voltage					
P090 *	Generator nominal value 1	-100.0 ... +100.0%	10.0				
P091 *	Generator nominal value 2	-100.0 ... +100.0%	-10.0				
P092 *	Generator time 1	0.1 ... 100 s	1.0				
P093 *	Generator time 2	0.1 ... 100 s	1.0				
P094 *	Ramp generator 1	ON/OFF	OFF				
P095 *	RG1 acceleration time	0.0 ... 850 s	0.0				
P096 *	RG1 deceleration time	0.0 ... 850 s	0.0				
P097 *	S-ramp generator	0.01 ... 6.50 s	0.01				
P098 *	S-ramp generator	ON/OFF	OFF				
P099 *	Inputs X1:28/X1:29	0, 1, 2, 3 or 4	0				
P100 *	Ramp generator 2	ON/OFF	OFF				
P101 *	RG2 acceleration time	0.0 ... 850 s	0.0				
P102 *	RG2 deceleration time	0.0 ... 850 s	0.0				

No.	Name	Range	Value in Data set 0 (SV 04.30)	Value in Data set 1	Value in Data set 2	Value in Data set 3	Value in Data set 4
P103 *	Display off Display on	0	Press mode key twice, display is off, keyboard disabled Keep counter key pressed for at least 1 s				
P104 *	Keypad enable	17					
P105	Nominal mains voltage	200 ... 500 V _{eff}	400 V				
P106	Display of all controller enables (see section 8, Parameters)	ON/OFF					
P107	Display of the relay functions (see section 8, Parameters)	ON/OFF					
P108	Display of the status of terminals X1:26,27,28,29 (see section 8, Parameters)	ON/OFF					
P109	Clear EEPROM	6					
P110 *	Armature/mains voltage	0.50 ... 1.21	1.00				
P111	Final rectifier position	35°	Display				
P112	Final inverter position	150°	Display				
P113 *	Scaling nominal value source 2	0.00 ... 2.00	1.00				
P114 *	Offset nominal value source 2	-100 ... +100%	0				
P115 *	n _{nom} = 0 lock	0, 1 or 2	0				
P116 *	n _{nom} = 0 threshold	0.1 % ... 5.0%	0.5				
P117 *	Pull-in time I _F monitoring	0.5 ... 30.0 s	0.8				
P118	Gear stage	1 ... 4					
P119	Nominal current of field device	0.5 ... 25 A	Display				
P120 *	Hysteresis I _A > I _x K3/1	1 ... 40%	2				
P121 *	Delay I _A = 0 message	0 ... 30 (sampling intervals)	0				
P122 *	Field feed in monitoring	ON/OFF	ON				
P123 *	Fast brake	1 or 2	1				
P124 *	Drive inhibit function	1 or 2	1				
P125 *	Scaling analog output 2	0.20 ... 1.00	1.00				
P126 *	Thermic time constant motor	0 ... 180 min	0				
P127 *	Threshold for I ² t	50 ... 110%	95				

No.	Name	Range	Value in Data set 0 (SV 04.30)	Value in Data set 1	Value in Data set 2	Value in Data set 3	Value in Data set 4	
P128 *	Relay output K4	0 or 1	0					
P129	Display loaded/programmed data set (see chapter 8, Parameters)							
P130 *	Analog output channel 3	0 ... 47 (see P088)	1					
P131 *	Analog output channel 4	0 ... 47 (see P088)	4					
P132 *	Scaling analog output channel 4	0.20 ... 1.00	1					
P133 *	Acceleration factor (lifting equipment)	0.5 ... 50.0	1.0					
P134 *	Field weakening range (lifting equipment)	1.0 ... 4.0	1.0					
P135 *	Gear efficiency factor (lifting equipment)	0.58 ... 1.00	1.0					
P136 *	Load measurement (lifting equipment)	ON/OFF	OFF					
P137 *	Scaling max. nom. value (lifting equipment)	0.50 ... 1.00	1.00					
P138 *	Threshold tacho polarity (error 39)	10 ... 62%	10					
P139	Device type	d = BKD6/F = BKF12	Display					
P140 *	Threshold tacho wire break (error 38)	20 ... 65%	10					
P141 *	Delay time armature open	1.0 ... 10.0 s	1.0					
P142 *	Maximum speed value	100 ... 6000 RPM	1000					
P143 *	Rotary encoder resolution	250 ... 4096	1024					
P144 *	Rot. enc. polarity change	ON/OFF	OFF					
P145 *	Field weakening mode	0 or 1	0					
P146 *	Timeout firing pulses disable	0.2 ... 2.0 s	0.2					
P147 *	Phase failure < 400 msec	ON/OFF	OFF					
P148 *	Load data set mode	1 or 2	1					
P149 *	Nominal value multiplier	0.00 ... 1.00	1.00					

No.	Name	Range	Value in Data set 0 (SV 04.30)	Value in Data set 1	Value in Data set 2	Value in Data set 3	Value in Data set 4
P150 *	Reserved						
P151 *	Reserved						
P152 *	Reserved						
P153 *	Reserved						
P154 *	Reserved						
P155 *	Reserved						
P156 *	Mains failure timeout	0.0 to 6.0	0.0				
P157 *	Release delay K2/0	0.0 ... 30.0	0.0				
P158 *	Multiplier P070/P078	0 or 1	0				
P159 *	Cyclical error display (see error list)	1 ... 115					
P160 *	n_{nom} limit mode (lifting equipment)	1 or 2	1				
P161 *	n-interpolation point 1 (lifting equipment)	25 ... 100%	100				
P162	M-interpolation point 2 (lifting equipment)	10 ... 100%	100				
P163 *	n-interpolation point 2 (lifting equipment)	25 .. 100%	100				
P164 *	M-interpolation point 3 (lifting equipment)	10 ... 100%	100				
P165 *	n-interpolation point 3 (lifting equipment)	25 .. 100%	100				
P166 *	M-interpolation point 4 (lifting equipment)	10 ... 100%	100				
P167	Base load (lifting equipment)	0 ... 100%	0				
P168 *	Lower measuring limit (lifting equipment)	5 ... 50%	20				
P169 *	Upper measuring limit (lifting equipment)	50 ... 95 %	80				
P170 *	Frequency limit	45.0 ... 65.0 Hz	65				
P171 *	Relay output K2	0 or 1	0				
P172 *	$I_A > I_x$ K2/1	5 .. 120%	95				
P173 *	Response time $I_A > I_x$ K2/1	0.0 ... 30.0 s	1.0				

No.	Name	Range	Value in Data set 0 (SV 04.30)	Value in Data set 1	Value in Data set 2	Value in Data set 3	Value in Data set 4
P174 *	Linking relay K2/1 - K3/1	ON/OFF	OFF				
P175 *	Linking time relay K2/1 - K3/1	0 ... 900 s	60				
P01F	Check sum BDS		Display via PC				
P07F	Display parameters (Setting on PC display)	0 ... 175	1				

8 PARAMETERS

Parameter List Software Version S04.03 and Above

NOTES

- * These parameters are components of a data set.
Use command P004 = 1, 2, 3 or 4 (corresponding to data set 1, 2, 3 or 4) to store changed parameters in the EEPROM. This overwrites existing values.
- + These are parameters with basic functions that apply to all data sets of the unit (P001, P006, P007, P009).
With no designation: functions or displays that can only be used in conjunction with the power converter.
- The specified times apply at $f = 50 \text{ Hz}$! At different mains frequencies, the following applies
- $$t' = t \cdot \frac{50 \text{ Hz}}{f_{\text{mains}}}$$

P000 **Power stage** Ident./control menu
Display of the device's nominal current in amps to calculate parameter P025.
Range: 30 A ... 600 A and > 600 A

P001 + **Communication source** (can only be changed with the keypad) Ident./control menu
When you change the communication source, the main contactor is switched off and the keypad is locked! The display is to one decimal place. The place before the decimal point indicates the communication source stored in the EEPROM. (Exception: During EEPROM programming, a 9 is displayed). The place after the decimal point indicates the current communication source that is stored in RAM.

Range: 0 ... 3

Input Values	Meaning
0	Keypad on power converter
1	Service PC
2	Control via interface board
3	Control via interface board and parameterization via keypad input

Default value: 0

Parameters

P002 **Rotating field** Ident./control menu

Before switching on the main contactor for the first time, "u" is displayed.

Range:

Displayed Value	Meaning
u	Not specified
Rdf	Clockwise
Ldf	Counterclockwise

P003 **Software version**

Under this parameter, the system displays the current software version of the power converter.

P004 **Program EEPROM data set** Ident./control menu

The parameters that are marked with an asterisk (*) are stored in the EEPROM by means of command P004. The existing values are overwritten.

Range: 1 ... 4

Input Values	Meaning
1	Program data set 1
2	Program data set 2
3	Program data set 3
4	Program data set 4

Default value: 0

P005 **Read single error**

For error list, see the chapter entitled Maintenance.

Range: 0 ... 113

P006 + Boot source Ident./control menu

Sets the boot source on the stored data set (P004 = 1, 2, 3 or 4). When you switch on again, this allows you to start working with the correct data set straight away.

Range: 1 ... 4

Value	Meaning
1	Boot source is EEPROM data set 1
2	Boot source is EEPROM data set 2
3	Boot source is EEPROM data set 3
4	Boot source is EEPROM data set 4

Default value: 0

P007 + Left rotary field lock Ident./control menu, S04.07 and above

Range: ON ... OFF

Value	Meaning
ON	Operation with left rotary field is not possible
OFF	Operation with left rotary field is possible

With OFF set, you must switch on components in the order below:

Power unit	Electronic feed	Field feed
AK1 to L3 AK3 to L2 AK5 to L1	X2:1 to L3 X2:2 to L1	X2:6 to L3 X2:7 to L1 or X3:1 to L3 at 25 A X3:2 to L1 Field device

Connection monitoring of the power unit and the field feed are still active.

Default value: ON

Parameters

P008 **Load data set** Ident./control menu
Data set can be changed during operation, see P148.

NOTE

During operation, do not change from field weakening to constant field!

Range: 0 ... 4

Value	Meaning
0	EPROM default data set
1	EEPROM data set 1 is loaded
2	EEPROM data set 2 is loaded
3	EEPROM data set 3 is loaded
4	EEPROM data set 4 is loaded

Default value: 0

P009 + **Start parameter** Ident./control menu
Sets the parameter that is shown after switching on the display.

Range: 0 ... 175

Default value: 1

P010 * **n_{act} smoothing** Speed controller menu
Range: 5 ms ... 100 ms
Default value: 5 ms
 10 ms S04.25 and above

P011 * **P–amplification** Speed controller menu
Range: 1 ... 100
Default value: 10

P012 * **Integral–action time** Speed controller menu
Range: 20 ms ... 9.99 s
Default value: 200 ms
 500 ms S04.08 and above

P013 **Reserved**

P014 * **Current limit TD1** Speed controller menu

For current limit switching, refer to P021.

Range: 0% ... 100%

Default value: 100%

P015 * **Current limit TD2** Speed controller menu

For current limit switching, refer to P021.

Range: 0% ... 100%

Default value: 100%

P016 * **Current limit reduction at n_x** Speed controller menu

Range: 0% ... 100% of n_{nom}

Default value: 100%

P017 * **Current limit at n_{max}** Speed controller menu

Range: 0% ... 100% of I_{Anom}

Default value: 100%

P018 * **Integral-action time** Speed controller menu

Range: ON ... OFF

Value	Meaning
ON	n-controller with PI action
OFF	n-controller with P action

Default value: ON

P019 * **Speed controller offset** Speed controller menu

Range: -400 ... +400

Corresponds to: -2.4% ... +2.4% of n_{nom}

Default value: 0

Parameters

P020 * **I x R** Precontr. IA Val. menu

Measured at P081 = 1 or P081 = 4

Range: 0.0% ... 30.0%
0.0% ... 50.0%

S04.15 and above

Default value: 4.5%

P021 * **Current limit switching** Speed controller menu

Range: 1 ... 2

Value	Meaning
1	P014 = Current limit for torque direction 1 P015 = Current limit for torque direction 2
2	P014 = Current limit for driving P015 = Current limit for braking

Default value: 1

P022 * **Speed controller preset** Speed controller menu

This improves the starting response of hoist drives. With BKF's, a preferred torque direction is set at the same time, which corresponds to the polarity of the preset value. With the controller disabled, the system immediately takes the value into the speed controller's I component; with an enabled controller, this does not take place until the next time the drive is disabled.

Range: -100.0% ... +100.0% of I_{Anom}

Default value: 0.0%

P023 * **$I_{A_{mot}}/I_{A_{max}}$** Monitoring menu

This sets the motor I_t monitoring in operation at overstress.

Example: The motor is to be operated at 1.6-fold overstress. $P023 = 1 \div 1.6 = 0.63$

(see also parameters P025, P069, P126, P127)

In addition, parameter P023 has an effect on load measurement (S04.12 and above)

Range: 0.50 ... 1.00

Default value: 1.00

P024 * **Gapping current limit** Precontr. IA Val. menu

This is set with P081 = 1 or P081 = 4

Range: 1% ... 100% of I_{Anom}

Default value: 30%

- P025** * **IA_{max}/device nom. current** Precontr. IA Val. menu
 P025 = Motor nominal current/device nominal current in S1 operation or
 P025 = Max. armature current/ device nominal current in intermittent operation
 In P062, the armature current set with P025 (i.e. the device output current/device nominal current) is displayed as 100%!
Range: 0.50 ... 1.00 of the device nominal current
Default value: 1.00
- P026** * **IA_{nom}-idle time** Precontr. IA Val. menu
 This parameter is set to 1 and you may not change it.
Range: 0 ... 2
Default value: 1
- P027** * **Gear protection current** Precontr. IA Val. menu
 Brief current limitation to protect the gears when the torque changes.
Range: 0% ... 100% of I_{Anom}
Default value: 100%
- P028** * **Gear protection time** Precontr. IA Val. menu
 Brief current limitation to protect the gears when the torque changes.
Range: 0 ms ... 100 ms
 0 ms ... 500 ms S04.05 and above
Default value: 0 ms
- P029** * **Armature inductivity** Precontr. IA Val. menu
 This is measured with P081 = 1 or P081 = 4.
Range: 0.0 ... 150.0
Default value: 10.0
- P030** * **IA_{nom}-integrator** Armat. curr. contr. menu
 Specifying the current rise in the armature circuit.
Range: 0 ms ... 100 ms
Default value: 6 ms

Parameters

P031 * P–amplification Armat. curr. contr. menu

This is optimized with P081 = 2 or P081 = 4

Range: 0.05 ... 0.80

Default value: 0.12

P032 * Integral–action time Armat. curr. contr. menu

This is optimized with P081 = 2 or P081 = 4.

Range: 5 ms ... 100 ms

Default value: 32 ms

P033 * Integral–action time (IA–gapping) Armat. curr. contr. menu

Range: 0.2 ms ... 10.0 ms

Default value: 8 ms

P034 * Gapping current adaption Armat. curr. contr. menu

Range: ON ... OFF

Value	Meaning
ON	P033 effective, adaptive armature current controller
OFF	P033 not effective

Default value: ON

P035 * Integral–action time Armat. curr. contr. menu

If P035 is OFF, gapping current adaption is also switched off.

Range: ON ... OFF

Value	Meaning
ON	PI armature current controller
OFF	P armature current controller

Default value: ON

P036 * Current precontrolling Precontr. IA Val. menu

Range: ON ... OFF

Value	Meaning
ON	Current precontrolling active
OFF	No current precontrolling

Default value: ON

P037 * Scaling IA precontrol Precontr. IA Val. menu
S04.08 and above

Influencing current precontrolling. With a value of 1.00, current precontrolling is completely effective; at 0.00, current precontrolling is not effective. If the value is set to 0.00, it is not possible to determine the armature inductivity with optimization run P081 = 1! The system cancels the optimization run with a controller disable.

Range: 0.00 ... 1.00

Default value: 1.00

P038 * Source IA precontrolling Armat. curr. contr. menu
S04.13 and above

Range: 1 ... 2

Value	Meaning
1	e.m.f. is used for current precontrolling
2	Analog tachometer or rotary encoder is used for current precontrolling. This is only effective with controller structures "0" and "2" (P083). With all other controller structures, you can, it is true, set P038 to "2" but the system still uses e.m.f. for current precontrolling

Default value: 1

Parameters

P039 * **Field unit ON/OFF** Field current controller menu
S04.05 and above

Range: ON ... OFF

Value	Meaning
ON	Internal field unit in operation
OFF	The field power converter's firing pulses are disabled; the field current monitoring is switched off and error message "24" (min. field current out of lower range) is no longer active, the field unit is switched off

Default value: ON

P040 * **P–amplific. UA controller (P083 = 1, 3)** , ,
Field current controller menu
S04.08 and above

Range: 0.1 ... 20.0

Default value: 3.0
1.5

P041 * **Integ.-act. time UA controller- (P083 = 1, 3)** Field current controller menu

Range: 20 ms ... 999 ms

Default value: 180 ms

P042 * **Cross-over/Arma. voltage** Field current controller menu

Effective with field weakening P083 = 1, 3.
Setting of the armature voltage/e.m.f. from which onwards field weakening starts to become effective (see also P145).

Range: 0.50 ... 1.00

Default value: 0.95

P043 * **P–amplific. IF controller** Field current controller menu

Range: 0.1 ... 20.0

Default value: 1.0

P044 * **Integ.–act. time IF controller** Field current controller menu
S04.08 and above

Range: 20 ms ... 999 ms

Default value: 120 ms
180 ms

P045	Reserved	
P046	Field current nominal value	Field current controller menu
	For display only!	
	Range: 0% ... 100% of I_{Fnom}	
P047	* Minimal field current	Field current controller menu
	Only effective with field weakening P083 = 1, 3.	
	$P047 = 80\% \cdot \frac{\text{Min. field current}}{\text{Max. field current}}$	
	Range: 20% ... 99%	
	Default value: 90%	
P048	Field current monitoring	Field current controller menu
	For display only, 50% of P047 or P049.	
P049	* I_{Fmax}/device nom. current	Field current controller menu
	$P049 = \frac{\text{Motor field current}}{\text{Field device nominal current}}$	
	If the calculated value is outside the setting range, you must use a larger or a smaller field device.	
	The field current that you set with P049 is shown in P064 as 100%!	
	Range: 0.40 ... 1.00	
	0.20 ... 1.00	S04.15 and above
	Default value: 1.00	
P050	Speed nominal value	Nominal values menu
	P080 \neq 4: Display only	
	P080 = 4: Nominal value with serial setting using a PC or controller (P001 = 1, 2, 3)	
	Range: -100% ... +100%	
	-100.0% ... +100.0% (displayed)	S04.09 and above
P051	* Internal nominal value 1	Nominal values menu
	See also P099 = 1.	
	Range: -100.0% ... +100.0%	
	Default value: 10.0%	

Parameters

P052	*	Internal nominal value 2	Nominal values menu
		See also P099 = 1.	
		Range: -100.0% ... +100.0%	
		Default value: -10.0%	
P053	*	Internal nominal value 3	Nominal values menu
		Range: -100.0% ... +100.0%	
		Default value: 5.0%	
P054	*	Internal nominal value 4	Nominal values menu
		Range: -100.0% ... +100.0%	
		Default value: -5.0%	
P055	*	Motorized pot. upper limit	Nominal values menu
		Only effective with P080 = 10.	
		Range: -99.9% ... +100.0%	
		Default value: 100.0%	
P056	*	Motorized pot. lower limit	Nominal values menu
		Only effective with P080 = 10; P056 must be lower than P055.	
		Range: -100.0% ... +99.9%	
		Default value: 0.0%	
P057	*	Motorized pot. accel. time	Nominal values menu
		The time applies to a 100% change of speed. P057 applies to positive nominal values and to deceleration with negative nominal values and is only effective with P080 = 10.	
		Range: 0.1 s ... 100.0 s	
		0.1 s ... 850.0 s	S04.27 and above
		Default value: 5.0 s	

P058 * Motorized pot. decel. time Nominal values menu

The time applies to a 100% change of speed. P058 applies to negative nominal values and to deceleration with positive nominal values and is only effective with P080 = 10.

Range: 0.1 s ... 100.0 s
 0.1 s ... 850.0 s S04.27 and above

Default value: 5.0 s

P059 + Motor pot. memory value Nominal values menu

This is activated via P099 = 3 and X1:28. For display purposes only.

Range: 0% ... ±100%

P060 Speed actual value

This is for display purposes only. The system shows the current speed in percent. 100% corresponds to the set nominal value of the motor.

P061 Armature voltage actual value

This is for display purposes only. The system shows the current armature voltage in percent. 100% corresponds to the set nominal armature voltage of the motor.

P062 Armature current actual value

This is for display purposes only. The system shows the current armature current in percent. This corresponds to the armature current you set using P025.

P063 Temperature of power stage

This is for display purposes only.

Range: 0 ... +100 °C

P064 Field current actual value

This is for display purposes only. The system shows the current field current in percent. This corresponds to the field current you set using P049.

P065 Reserved

Parameters

P066	Mains frequency	
	This is for display purposes only. The system shows the current mains frequency in Hertz.	
P067	Mains voltage	
	This is for display purposes only. The system shows the current mains voltage in V_{eff} .	
P068	Consumed power	
	This is for displaying $U_A \cdot I_A$ only. The system shows the power supplied to the motor in percent. 100% corresponds to the motor's rated power.	
P069	I²t value	Monitoring menu
	This is for display purposes only. 100% corresponds to the motor's rated temperature (calculated from the armature current).	
P070	* n > n_x output K2/0	Monitoring menu
	100% corresponds to the set rated motor speed, with P158 = 0.	
	Range:	1% ... 105% with P158 = 0 0.1% ... 10.5% with P158 = 1
	Default value:	1%
P071	* n > n_x K3/2	Monitoring menu
	100% corresponds to the set rated motor speed.	
	Range:	1% ... 105%
	Default value:	50%
P072	* n_{act} > n_{nom} K3/0/5	Monitoring menu
	Hysteresis: $\pm (0.1 \cdot \text{setting value} + 0.4\%)$, above a setting value of 21% constant $\pm 2.5\%$	
	Range:	1% ... 15% 1% ... 60% S04.15 and above
	Default value:	5%

P073 * **$I_A > I_x$ K3/1** Monitoring menu

Hysteresis refer to the diagram in chapter 6.5.
100% corresponds to the device output current you set using P025.

Range: 5% ... 120%

Default value: 95%

P074 * **Delay $I_a > I_x$ K3/1** Monitoring menu

Release delay constant 100 ms.

Range: 0.0 s ... 30.0 s

Default value: 1.0 s

P075 * **Reduced field** Field current controller menu

This is for reducing the temperature of the motor in breaks in operation; it is only effective with main contactor OFF (X1:22 open).

Range: ON ... OFF

Value	Meaning
ON	Field current is reduced with main contactor OFF
OFF	Field current is not reduced with main contactor OFF

Default value: OFF

P076 * **Time for reduced field P075** Field current controller menu

Delay for P075. Is only effective with P075 = ON.

Range: 0 s ... 180 s

Default value: 30 s

P077 * **$I_{F_{nom}}$ reduced field** Field current controller menu

Referred to the field current you set using P049. Is only effective with P075 = ON.

Range: 20% ... 100%

Default value: 30%

Parameters

P078 * **n < n_x for fast brake** Monitoring menu

Brakes the drive on $n < P078$ and then switches off the drive on fast braking; this also affects LED H19.

Range: 1% ... 20%
 1% ... 100% with P158 = 0 S04.15 and above
 0.1% ... 10.0% with P158 = 1

Default value: 5%

P079 * **Main contactor edge** Ident./Control menu

Can only be switched off in the case of P001 = 1, 2 or 3.

Range: ON ... OFF

Value	Meaning
ON	On switch-on or following an error which you removed, the system must carry out an L⇒H switching operation at input X1:22.
OFF	The main contactor stays on, after you remove the error, the drive must be switched on by means of a serial enable.

Default value: ON

P080 * Nominal value source

Configuration menu

To use nominal value sources 12 to 14, you need supplementary module 3.9217 (Digital Input/Output Expansion). The system transfers a new nominal value if it has been pending and stable at the input for four controller cycles (approx. 15 ms). The system limits the nominal values internally to the specified format.

Range: 1 ... 16

Value	Meaning
1	Analog 1 (differential amplifier) Analog adaptation: potentiometer R100 (v = 0.9 ... 2.0)
2	Analog 2 (summing amplifier) Digital adaptation: P113, P114
3	Analog 1 + 2; P113, P114
4	Digital (serial) Setting via P050 when P001 = 1, 2, 3
5	Internal specified value generator For value, see P090 ... P093
6	Internal specified value 1 For value, see P051
7	Internal specified value 2 For value, see P052
8	Internal specified value 3 For value, see P053
9	Internal specified value 4 For value, see P054
10	Motorized potentiometer For value, see P055 ... P058
11 (S04.11 and above)	Specified value setting via dual-port RAM no protocol 16-bit. Can only be used in conjunction with InterBus-S daughterboard PCB 3.9208.
12 (S04.11 and above)	Parallel specified value setting 15-bit twos complement. Permissible value range: \$3FF0 to \$4010. PCB 3.9217 needed.
13 (S04.11 and above)	Parallel specified value setting 14-bit and sign. Permissible value range: \$0 to \$3FF0. If bit no. 15 = 1, the value is interpreted as a negative number (amount + sign). PCB 3.9217 needed.
14 (S04.11 and above)	Parallel specified value setting 12-bit and sign. Decimal specified value setting (amount + sign). Permissible value range: 0 to 999 (percentual setting). If bit no. 15 = 1, the value is interpreted as a negative number. If a code is entered in one of the three places that is not a decimal number, the system does not accept the specified value. PCB 3.9217 needed.
15 (S04.28 and above)	Sum of specified value sources 2 and 4 P113, P114, P001
16 (S04.15 and above)	Analog specified value via differential amplifier and analog additional specified value via summing amplifier. Has a similar effect to P080 = 3, however the specified value from the differential amplifier is routed directly to the speed controller and the specified value from the summing amplifier is transferred to the speed controller via the ramp function generator. P149 does not affect P080 = 16, P113, P114, P094, P095, P096 or P100, P101, P102

Default value: 1

P081 * Optimization run Configuration menu

Specify the value with the controller disabled, enable the controller, block the motor. The field is switched off while optimization run P081 = 1, 2 and 4.

If there is a controller disable in the optimization run and with S04.20 and above, P081 is set to 0.

Range: 0 ... 6

Value	Meaning
0	No optimization run selected
1	Characteristic curve optimization
2	Current controller optimization
3	Reserved
4	Characteristic curve and current controller
5	Reserved
6 (S04.05 and above)	Determination of the acceleration factor. This is only important in the context of parameters P134 to P137. The system determines the value of parameter P133. See also P133, P167 and P136.

Default value: 0

P082 * Armature voltage adjustment Speed controller menu

Speed adjustment in the case of e.m.f. control

Range: 0.90 ... 1.10

Default value: 1.00

P083 * Controller structure Configuration menu

NOTE!

Switch from field weakening to constant field with controller disable and n = 0 only!

Range: 0 ... 5

Value	Meaning
0	Speed control with analog tachometer and constant field Speed adjustment with R 103
1	Speed control with analog tachometer and field weakening Speed adjustment with R103
2 (S04.09 and above)	Speed control with actual value rotary encoder and constant field (see also P142 to P144)
3 (S04.09 and above)	Speed control with actual value rotary encoder and field weakening (see also P142 to P144)
4	e.m.f. control with constant field
5	Current control with constant field

Default value: 4

P084 * Programmable analog input X1:9

Configuration menu

Range: 0 ... 13

Value	Meaning
0	No function, input deactivated
1	Current limit for torque direction 1, torque direction 2 is unaffected 0 V to +10 V corresponds to 0 to 100% current limit < 0 V corresponds to 0% current limit, torque direction 2 is unaffected
2	Current limit for torque direction 2 (setting same as 1), TD1 is unaffected
3	Current limit for torque directions 1 and 2 symmetrical (setting same as 1)
4 (S04.15 and above)	The current nominal value is multiplied by the value of P149 once/while a LOW level is pending at terminal X1:9. This has no effect with P080 = 16
5	Nominal value polarity reversal switch (on the ramp function generator input) LOW level: 0 V or input open (approx. 0 V ... 5 V) HIGH level: 24 V (approx. 7.5 V ... 30 V) = polarity reversal active
6	Nominal value zeroing On the ramp function generator input without resetting the ramp function generator \Rightarrow ramp-down time effective LOW level: 0 V or input open (approx. 0 V ... 5 V) HIGH level: 24 V (approx. 7.5 V ... 30 V) = nominal value zeroing active
7	Nominal value zeroing on the ramp function generator input with resetting of the ramp function generator, active with HIGH level at X1:9
8 (S04.05 and above)	Analog setting of the field current nominal value +10 V corresponds to 100% of the field current value (referred to P049), -10 V to +1 V and open terminal corresponds to 10% of the field current value. The field current nominal value is accepted with controller structures without field weakening only. (See also parameters P046, P049, P083)
9 (S04.17 and above)	Ramp function generator stop with a HIGH level at terminal X1:9
10 (S04.21 and above)	0 V to +10 V corresponds to 0 to 100% external current limit for TD1 and 0% for TD2 0 V to -10 V corresponds to 0 to 100% external current limit for TD2 and 0% for TD1
11 (S04.21 and above)	0 V to +10 V corresponds to 0 to 100% external current limit for TD2 and 0% for TD1 0 V to -10 V corresponds to 0 to 100% external current limit for TD1 and 0% for TD2
12 (S04.22 and above)	ON/STOP simulation A special function that is only active with communications source P001 = 3
13 (S04.27 and above)	Quick start (after a brief mains power outage) If there is a voltage of > +12.5 V on X1:9 when the electronics supply is connected, the system is initialized more quickly (approximately 800 to 900 ms) and the drive starts automatically, assuming that all the enables (X1:22 to X1:25) are available. In the case of an interruption of phase L2, for example, the restart takes approximately 500 to 600 ms.
DANGER Terminal X1:9 may not be hard-wired; instead, you must control it by means of a contact, taking into account the machine's safety regulations.	

Default value: 0

Parameters

P085 * Relay output K3

Monitoring menu

Range: 0 ... 5

Value	Meaning
0	$n_{nom} = n_{act}$ at ramp function generator input Picks up: if the deviation is less than the threshold set with P072 Drops: if the threshold set with P072 is exceeded
1	$I_A > I_X$ Armature current monitoring Picks up: if the armature current exceeds the switching threshold (P073) for longer than the specified response time (P074). Hysteresis can be set via P120.
2	$n > n_X$ Picks up: if the speed exceeds threshold $n > n_X$ (P071)
3 (S04.04 and above)	Drive ready to start Picks up: if cancellation has been carried out of pulse enable, main contactor ON, fast brake and ready for use. In this context, controller enable X1:23 and serial controller enable are ignored. Drops: If one of the conditions is missing
4	Field monitoring Picks up: if the field current is $> 80\%$ of I_{fnom} Drops: if the field current is $< 50\%$ of I_{fnom}
5	$n_{act} = n_{nom}$ at speed controller input Picks up: if the deviation is less than the threshold set with P072 Drops: if the threshold is exceeded

Default value: 0

P086 * Stalled motor monitoring

Monitoring menu

Range: ON ... OFF

Value	Meaning
ON	Monitoring is switched-on
OFF	Monitoring is switched-off

Default value: ON

P087 * Stalled motor monitoring

Monitoring menu

Range: 0.1 s ... 30.0 s

Default value: 5.0 s

- P088** * **Analog output channel 1 (X1:11, reference potential to 12)** Configuration menu
- P089** * **Analog output channel 2 (X1:13, reference potential to 14)** Configuration menu

Output standardized to 0 ... ± 10 V. Refresh rate 3.3 ms, resolution 150 mV.

Scaling of channel 2 via P125, higher 10–mV resolution possible using supplementary module "2 x DAC 12" (PCB 3.9201 or PCB 3.9217).

Range: 1 ... 47

Value	Meaning
1	Speed nominal value
2	Ramp function generator output
3	Nominal value on n–controller
4	Speed actual value
5	Armature voltage
6	EMF
7	n–controller output
8	Amount n–controller output
9	Amount I_{act} ($+I_{Aact}$)
10	I–controller output
11	Power
12	Field current nominal value
13	Field current actual value
14	Field current controller output
15	Inverter input
16	Inverter output
17	n–controller P component
18	n–controller I component
19	Torque signalling
20	ZIL (second pulse suppr.)
21	Ripple limit
22	Ripple characteristic
23	e.m.f. compensation
24	I x R
25	U–α
26	Queue
27	I controller P component
28	I controller I component
29	I _f controller P component
30	I _f controller I component
31	Field U _A controller P component
32	Field U _A controller I component
33	Controller enable/disable

Parameters

P088 * **Analog output channel 1 (X1:11, reference potential to 12)** Configuration menu

P089 * **Analog output channel 2 (X1:13, reference potential to 14)** Configuration menu

Value	Meaning
34	Current limit
35	Amount n_{act}
36	I_{act} (+/-)
37	I^2t value
38	Drive/Brake
39	Polarity n_{act}
40 (S04.05 and above)	Load, 0 ... 10 V corresponds to a load torque of 0 ... 100%.
41 (S04.05 and above)	Permissible nominal value
42 (S04.05 and above)	Field curr. monitoring threshold
43 (S04.22 and above)	Torque signalling inverted to 19
44 (S04.27 and above)	Current reserve $(-1) \cdot (I_{act} - 10 \text{ V})$ With a current actual value of 0 V (test point 9), this test point has an output voltage of +10 V; with a current actual value of +10 V, it has an output voltage of 0 V.
45 (S04.28 and above)	$- I_{act} $ inverted to 9
46 (S04.28 and above)	Inverted to 36
47 (S04.29 and above)	Mains voltage, e.g. +4.00 V corresponds to a mains voltage of 400 V _{eff}

Default value: 2 (measuring channel 1) = P088
3 (measuring channel 2) = P089

P090 * **Generator nominal value 1** Nominal values menu

Effective at P080 = 5.

Range: -100.0% ... +100.0%

Default value: 10.0%

P091 * **Generator nominal value 2** Nominal values menu

Effective at P080 = 5.

Range: -100.0% ... +100.0%

Default value: -10.0%

P092 * Generator time 1 Nominal values menu

Effective at P080 = 5.

Range: 0.1 s ... 100.0 s

Default value: 1.0 s

P093 * Generator time 2 Nominal values menu

Effective at P080 = 5.

Range: 0.1 s ... 100.0 s

Default value: 1.0 s

P094 * Ramp generator 1 Ramp generator menu

Only one ramp function generator at a time can ever be switched on, see P100!

Range: ON ... OFF

Value	Meaning
ON	Ramp function generator 1 switched-on
OFF	Ramp function generator 1 switched-off

Default value: OFF

P095 * RG1 acceleration time Ramp generator menu

The time applies to a 100% nominal value change.

Range: 0.0 s ... 850.0 s

Default value: 0.0 s

P096 * RG1 deceleration time Ramp generator menu

The time applies to a 100% nominal value change.

Range: 0.0 s ... 850.0 s

Default value: 0.0 s

P097 * S-ramp generator Ramp generator menu

Set the time to about 20% of P095/P096 or P101/P102.

Range: 0.01 s ... 6.50 s

Default value: 0.01 s

Parameters

P098 * S-ramp generator

Ramp generator menu

Range: ON ... OFF

Value	Meaning
ON	S-ramp generator switched-on
OFF	S-ramp generator switched-off

Default value: OFF

P099 * Inputs X1:28/X1:29

Ident./Control menu

LOW level: 0 V or input open (0 V ... + 5 V)

HIGH level: +24 V at input (+15 V ... + 30 V)

Range: 0 ... 4

Value	Meaning
0	Switching inputs inactive
1	Inching For the duration of inching, ramp function generator 2 is switched-on automatically. After inching is completed, the original nominal value and ramp function generator apply. X1:28 HIGH level activates internal nominal value 1 (P051) X1:29 HIGH level activates internal nominal value 2 (P052)
2	No function
3	Motorized potentiometer memory function X1:28 A LOW \Rightarrow HIGH edge change stores the current motorized potentiometer value in the EEPROM (display with P059) X1:29 The HIGH level of the stored motorized potentiometer value is approached once all enables are active.
4	Reload and activate data set X1:28 X21:9 Data set is loaded to RAM LOW LOW No function, RAM data is not changed HIGH LOW Data set 1 LOW HIGH Data set 2 HIGH HIGH Data set 3 Parameter P099 = 4 must be set in all the data sets that are to be reloaded. It is not possible to secure switchover of data sets against impermissible or dangerous conditions, i.e. you must ensure that in the case of controller structure switchovers, the system cannot change over during operation from field weakening to constant field. For display, see P129. For locking, use P148.

Default value: 0

P 100 * Ramp generator 2 Ramp generator menu

Only one ramp function generator at a time can ever be switched on, see P094.

Range: ON ... OFF

Value	Meaning
ON	Ramp function generator 2 switched-on
OFF	Ramp function generator 2 switched-off

Default value: OFF

P 101 * RG2 acceleration time Ramp generator menu

The time applies to a 100% nominal value change.

Range: 0.0 s ... 850.0 s

Default value: 0.0 s

P 102 * RG2 deceleration time Ramp generator menu

The time applies to a 100% nominal value change.

Range: 0.0 s ... 850.0 s

Default value: 0.0 s

P 103 Display OFF, Display ON

Press the Mode key twice ⇒ display is off, keypad is locked

Press the ^ or v counter key for a relatively long period of time ⇒ display is switched on.

Default value: 0

P 104 Keypad enable

If P001 = 0, the value 17 gives the keypad access rights on the unit.

NOTE!

The value 17 is not shown after transfer! All other values block the keypad for manual inputs; reading out of parameter values is still possible.
You can only change parameter P001 (communication source) using the keypad!

P 105 * Nominal mains voltage

Ident./Control menu

Set this parameter to the nominal mains voltage.

NOTE!

400-V devices must not be run on a 500-V mains supply! Amongst other things, the setting is crucial for mains monitoring.

Range: 200 V_{eff} ... 500 V_{eff}

Default value: 400 V_{eff}

P 106 Display of all controller enables

The top bars show the status at input terminals X1:22 ... 24. The bars are lit-up with a HIGH level.

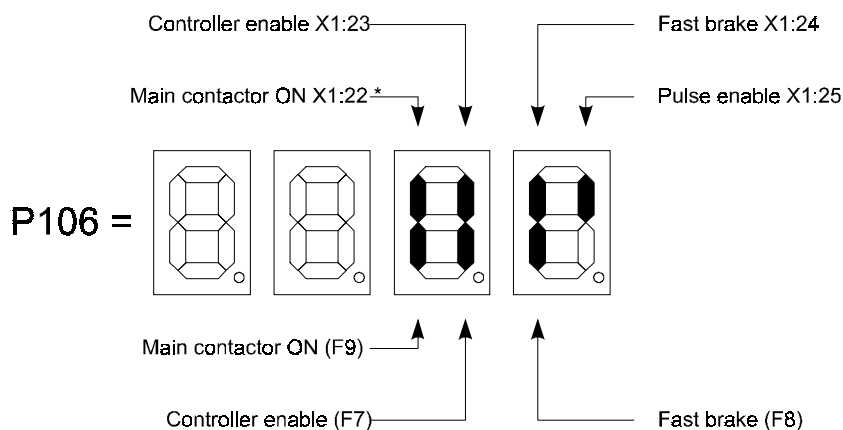

The bottom bars show the status of the serial command from the PC or the controller. The bars light up with an ON command. F7, F8 and F9 are function keys on the PC.

* Display of the static status. The switching edge at X1:22 may still be missing for controller enable.

P 107 Display of the relay functions

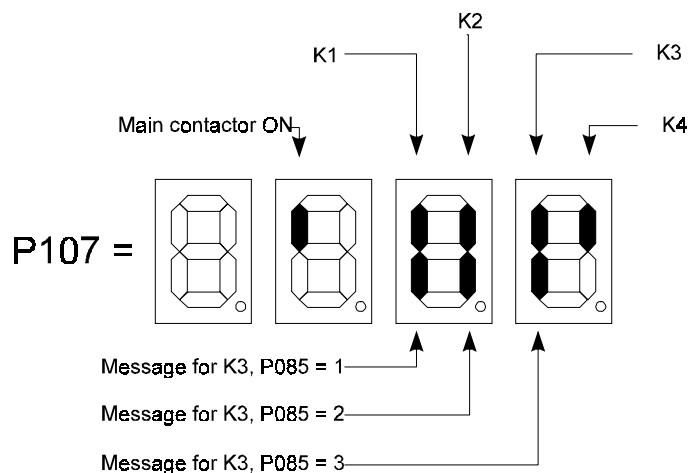

The bar lights up when the associated relay is triggered.

P 108 Display of the status of terminals X1:26, 27, 28, 29

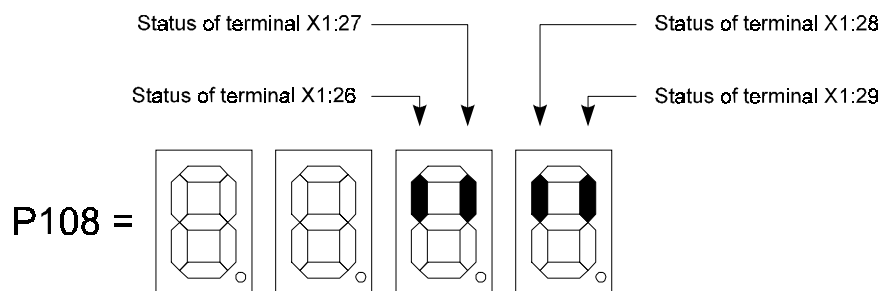

The bar lights up when a HIGH level is pending at the corresponding terminal.

P 109 Clear EEPROM

This is only possible with data collisions or memory errors in the EEPROM. During clearing, the system displays CLr in parameter P109 and then error 61 in P159.

Input value: 6

Parameters

P 110 * **Armature/mains voltage** Ident./Control menu

You must set this parameter correctly, since it affects the final rectifier position!

Range: 0.50 ... 1.21

Input values above 1.05 are possible with devices of series BKD only (see parameter P139)

Default value: 1.00

P 111 **Final rectifier position** Armat. curr. contr. menu

The setting is conditional on P110 and cannot be changed directly.

P 112 **Final inverter position** Armat. curr. contr. menu

Cannot be changed, 150° constant.

P 113 * **Scaling nominal value source 2** Configuration menu

Range: 0.00 ... 1.00

0.00 ... 2.00

S04.14 and above

Default value: 1.00

If you want to form a nominal value of -10 V ... +10 V from a nominal voltage of 0 V ... +10 V, for example, you must set P113 = 2.00 and P114 = -100%.

P 114 * **Offset nominal value source 2** Configuration menu

Range: -100% ... +100%

Default value: 0%

P 115 * **$n_{nom} = 0$ lock** Configuration menu

If the nominal value falls below the threshold (P116) you set using P116 and the speed actual value falls below the threshold set with P078, the system triggers the action set with P115.

Range: 0 ... 2

Value	Meaning
0	Not active
1	Speed controller's I component is short-circuited
2	Speed controller feedback is short-circuited. Enabling is carried out if the threshold set with P116 is exceeded. The lock is activated if the nominal value set with P116 and the actual value threshold set with P078 are fallen short of (drift lock).

Default value: 0

- P 116** * **$n_{\text{nom}} = 0$ threshold** Configuration menu
- Range:** 0.1% ... 5.0%
- Default value:** 0.5%
-
- P 117** * **Pull-in time I_F monitoring** Field current controller menu
- Triggering time for monitoring the minimum field current (threshold is 50% of the field current nominal value).
- Range:** 0.5 s ... 30.0 s
- Default value:** 0.8 s
-
- P 118** **Gear stage** Speed controller menu
S04.04 and above
- The system takes the values of the speed controller protective circuits (P011 and P012) from the data set specified with P118. All the other setting values are unchanged.
- Condition: The data set selected using P118 must have been programmed.
- If a complete data set is loaded, the system also changes the display value of parameter P118. Changing parameter P118 does not affect display of parameter P008. See also P008, P011, P012, P129.
- Range:** 1 ... 4
- Default value:** Same as boot source P006
-
- P 119** * **Nominal current of field device**
- Display only, is used for calculation of parameter P049.
-
- P 120** * **Hysteresis $I_A > I_x$ K3/1** Monitoring menu
- For the upper and lower limits, refer to the function plans.
- Range:** 1% ... 40%
- Default value:** 2%

Parameters

P 121 * Delay I_A = 0 message Precontr. IA Val. menu

The value is set internally in dependence on the armature inductivity P029, without this value being changed; however, the system uses the higher value in each case.

Range: 0 ... 30 (sampling interval is 3.3 ms at 50 Hz)

Default value: 0

P 122 * Field feed in monitoring Monitoring menu

Range: ON ... OFF

Value	Meaning
ON	After a reset, the system checks the field connection at initialization, field current monitoring is active!
OFF	The system does not check the field connection until the Main contactor ON command has been issued and field current monitoring has been activated.

Default value: ON

P 123 * Fast brake Configuration menu

Range: 1 ... 2

Value	Meaning
1	Fast braking at maximum torque
2	Fast braking at the ramp (P094 or P100 only if a ramp function generator is switched on)

Default value: 1

P 124 * Drive inhibit function Configuration menu

Range: 1 ... 2

Value	Meaning
1	Fast brake Controller disable at $n < n_x$ (P078) Main contactor stays on
2	Fast brake Additionally, main contactor is switched off at $n < n_x$ (P078) with enable, you must specify "Cancel fast brake" before "Main contactor ON".

Default value: 1

P 125 * Scaling analog output 2 Configuration menu

This parameter is for adaptation to a display instrument.
 $U = 10V \times P125$ for the nominal value of the selected test point.

Range: 0.20 ... 1.00
 0.20 ... 2.00 S04.30 and above

Default value: 1.00

P 126 * Thermic time constant motor Monitoring menu

Consult the motor manufacturer for the time constant.
 0 corresponds to monitoring inactive. With software version S04.23 and above, monitoring is not active during an optimization run.

Range: 0 min ... 180 min

Default value: 0 min

P 127 * Threshold for I²t Monitoring menu

Threshold for triggering I²t monitoring.

Range: 50% ... 110%

Default value: 95%

P 128 * Relay output K4 Monitoring menu

Range: 0 ... 1

Value	Meaning
0	Temperature monitoring This drops if the temperature of the power stage is OK and the motor's I ² t value (P127) has been fallen short of. It picks up if the temperature of the power stage is too high or the motor's I ² t value has been exceeded. Temperature LT is accessible via P063, motor's I ² t value (P069). Using this value, you can draw conclusions about the motor temperature.
1	Drive ON This drops if the temperature of the power stage is too high, the motor's I ² t value has been exceeded or the controller has not been enabled. It picks up if the temperature of the power stage is OK, the motor's I ² t value (P127) has been fallen short of and the controller has been enabled.

Default value: 0

P 129 Display loaded/programmed data set

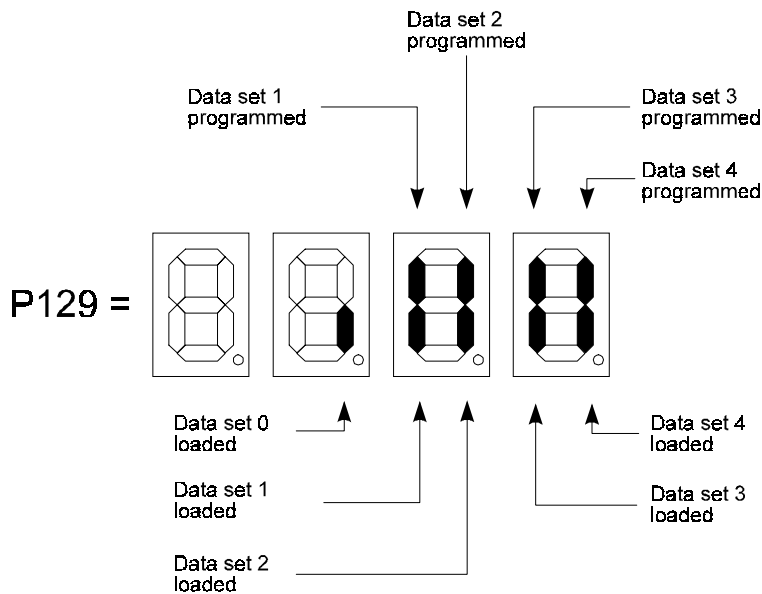

P 130 * Analog output channel 3

Configuration menu
S04.05 and above

P 131 * Analog output channel 4

Configuration menu
S04.05 and above

For function and description, refer to P088/P089, output standardized to $0 \dots \pm 10 \text{ V}$.
scaling of channel 4 via P132, 11-bit resolution (10 mV),

You need a supplementary module with the corresponding DACs.

PCB 3.9201:	Terminal X4:1	Signal of measuring channel 3
	Terminal X4:3	Signal of measuring channel 4
	Terminal X4:2/4	Reference potential
PCB 3.9217:	Terminal X7b:2	Signal of measuring channel 3
	Terminal X7b: 4	Signal of measuring channel 4
	Terminal X7b:1/3	Reference potential

Range: 1 ... 47

Default value: 1 (measuring channel 3) = P130
4 (measuring channel 4) = P131

P 132 * Scaling analog output channel 4

Configuration menu
S04.05 and above

This parameter is for adaptation to a display instrument.

$U = 10 \text{ V} \times P132$ for the nominal value of the selected test point.

Range: 0.20 ... 1.00
0.20 ... 2.00

S04.30 and above

Default value: 1.00

P 133 * Acceleration factor Precontr. IA Val. menu
S04.05 and above

In the case of load measurement with lifting drives or cranes with field weakening, this is needed for correct load calculation. See also P081, P134... P137 and P167.

Range: 0.5 ... 50.0

Default value: 1.0

P 134 * Field weakening range Precontr. IA Val. menu
S04.05 and above

This is needed for load measurement with lifting drives or cranes with field weakening. The setting value is the field weakening range of the motor being used. See also parameters P133, P135, P136, P137.

Range: 1.0 ... 3.0

1.0 ... 4.0

S04.12 and above

Default value: 1.0

P 135 * Gear efficiency factor Precontr. IA Val. menu
S04.05 and above

This is needed for load measurement with lifting drives or cranes with field weakening. The value is set correctly when the same load value is determined when lifting and lowering the same load. See also P133, P134, P136, P137 and P160 ... P166.

Range: 0.58 ... 1.00

Default value: 1.00

P 136 * Load measurement ON/OFF Precontr. IA Val. menu
S04.05 and above

This is needed for load measurement with lifting drives or cranes with field weakening. It is used to activate load measurement (P133 ... P135, P137 and P160 ... P167 effective/not effective). See also parameters P133 ... P135, P137 and P160 ... P167.

Range: ON ... OFF

Value	Meaning
ON	Load measurement switched-on
OFF	Load measurement switched-off

Default value: OFF

Parameters

P 137 * **Scaling max. nom. value** Precontr. IA Val. menu
S04.05 and above

This is needed for load measurement with lifting drives or cranes with field weakening. It is used to weaken the maximum permissible nominal value at load measurement, which the power converter calculated. See also P133, P134, P135, P136.

Range:	0.50 ... 1.00	
	0.50 ... 0.95	S04.09 and above
	0.50 ... 1.00	S04.12 and above
Default value:	1.00	
	0.80	S04.09 and above
	1.00	S04.12 and above

P 138 * **Threshold tacho polarity (error 39)** Monitoring menu
S04.04 and above

This is for setting the threshold from which onwards monitoring of the tachometer polarity is to become effective. The setting value is referred to the tachometer signal. A setting value of 50% means that the tachometer polarity is not monitored until $\pm 50\%$ of the speed has been reached. With setting values of 61% and 62%, monitoring is **switched off**. The power converter's display shows the message **OFF**.

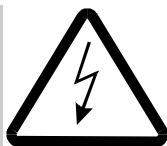

DANGER

If you set P138 to 61% or 62%, monitoring of the tachometer/encoder polarity is switched-off. In this case, the system does not detect polarity reversal of the tachometer/encoder. In the event of an error, this can lead to uncontrolled running!

Range:	10% ... 62%
Default value:	10%

NOTE

If the input value is increased and there is a tachometer/encoder failure, the drive is not switched off until a higher speed is reached!

P 139 **Device type**

Range:	d = BKD6 f = BKF12
---------------	-----------------------

P 140 * **Threshold tacho wire break (error 38)** Monitoring menu
S04.05 and above

Setting the threshold from which onwards monitoring of the tachometer wire break is to become effective. The setting value is referred to the armature voltage measured by the drive. A setting value of 30% means that tachometer wire break is not monitored until an armature voltage of 30% of the nominal armature voltage (P110) is reached. You cannot switch off monitoring.

Since the speed actual value determined by the power converter indicates the status of the actual value encoder, this does not represent a redundant safety system. Observe the regulations for the protection of people!

Range: 20% ... 65%
5% ... 65% S04.23 and above

Default value: 10%

NOTE

If the input value is increased and there is a tachometer/encoder failure, the drive is not switched off until a higher speed is reached!

Since the speed actual value determined by the power converter indicates the status of the actual value encoder, this does not represent a redundant safety system. Observe the regulations for the protection of people!

P 141 * **Delay time armature open (error 17)** Monitoring menu
S04.05 and above

Range: 1.0 ... 10.0 s

Default value: 1.0 s

P 142 * **Maximum speed value** Speed controller menu
S04.09 and above

See also parameters P083, P143 and P144.

Range: 500 RPM ... 6000 RPM
100 RPM ... 6000 RPM S04.11 and above

Default value: 1000 RPM

P 143 * Rotary encoder resolution Speed controller menu
S04.09 and above

The maximum speed that can be achieved with a rotary encoder is calculated as follows:

$$n_{\max} = \frac{(60 \cdot 100 \text{ kHz})}{P143} \quad [\text{RPM}]$$

With a 1024-increment encoder, parameter P142 can be set to a maximum of 5859 RPM. If you assign a higher value, the system sets P142 to 5859 RPM and error message 115 is issued. See also parameters P083, P142 and P144).

$$n_{\max} = \frac{(60 \cdot 300 \text{ kHz})}{P143} \quad [\text{RPM}] \quad \text{S04.25 and above}$$

Range: 250 ... 4096

Default value: 1024

P 144 * Rot. enc. polarity change Speed controller menu
S04.09 and above

This is needed if the directions of rotation of the motor and the encoder are different, due to the way in which the incremental encoder is mounted. See also parameters P083, P142 and P143.

Range: ON ... OFF

Value	Meaning
ON	Polarity reversal switched-on
OFF	Polarity reversal switched-off

Default value: OFF

P 145 * Field weakening mode Field current controller menu
S04.15 and above

Range: 0 ... 1

Value	Meaning
0	The armature voltage is used for field weakening control.
1	The e.m.f. is used for field weakening control.

Default value: 0

P 146 * Timeout firing pulses disable Monitoring menu
S04.15 and above

A settable watchdog timeout for the switchover logic. You add the 40–ms watchdog timeout to the entered value.

This also affects controller enable or main contactor OFF. With controller disable, the firing pulses stay in the inverter limit for this time until pulse clearance is issued. The main contactor is not switched off until this time +50 ms has elapsed.

Range: 0.2 s ... 2.0 s
 0.1 s ... 2.0 s S04.27 and above

Default value: 0.2 s

P 147 * Phase failure < 400 ms Ident./Control menu
S04.17 and above

Range: ON ... OFF

Value	Meaning
ON	With an appropriate switching mains unit, it is possible to buffer power failures lasting up to 400 ms.
OFF	In the case of a power failure, the drive issues an error and locks itself.

Default value: OFF

P 148 * Load data set mode Ident./Control menu
S04.10 and above

If a controller enable is issued during loading of a data set, the system delays the controller enable until the data set has been loaded, regardless of the setting of P148. Relay K4 "Drive ON" (P128 = 1) does not pick up either until the drive has really been enabled.

If the controller is enabled and P148 = 2, P099 = 4 and you choose a new data set by means of terminals X1:28 and X1:29 on PCB 3.8934 and the signals remain, the new data set is loaded immediately on inhibiting of the controller!

The setting of parameter P148 has no effect on P118 "Gear stage". You can always change the speed controller's protective circuit, i.e. even when the controller is enabled. See also parameters P008, P099, P118 and P128.

Range: 1 ... 2

Value	Meaning
1	It is always possible to load a data set, even if the controller is enabled
2	A data set can only be loaded when the controller is disabled. If the system tries to load a data set with the controller enabled, message 113 is issued.

Default value: 1

Parameters

P 149 * **Nominal value multiplier** Configuration menu
S04.15 and above

For function, see parameter P084. Has no effect with nominal value source 16 (P080 = 16).

Range: 0.00 ... 1.00

Default value: 1.00

P 150 *
to **P 155** Reserved

P 156 * **Mains failure timeout** Monitoring menu
S04.29 and above

You can only use this parameter with an external 24-V_{dc} UPS and an appropriate switching power supply in the power converter. P156 can only be set to values not equal to 0.0 s if P084 ≠ 13 and P147 = OFF.

In the case of mains failures that are shorter than the period set using P156, the drive starts automatically on restoration of power, assuming that all the enables on the unit are still present. With longer mains failures, the power converter takes on the disturbed state.



WARNING

Due to the fact that the machine starts automatically on restoration of power, you must observe applicable safety regulations of the machine when setting the time!

Range: 0.0 ... 6.0 s

Default value: 0.0 s

P 157 * **Release delay K2/0** Monitoring menu
S04.25 and above

This parameter is only effective if relay K2 with parameter P171 = 0 is assigned the function $n > n_x$.

Range: 0.00 s ... 30.00 s

Default value: 0.00 s

P 158 * Multiplier P070/P078Monitoring menu
S04.15 and above

For parameters P070 ($n < n_{\min}$ for K2) and P078 ($n < n_{\min}$ for fast brake), the speed actual value is multiplied by 1 or "10" before the system polls the threshold. This results in a minimum monitoring threshold of 0.1% of n_{nom} .

Range: 0 ... 1

Value	Meaning
0	P070 = 1 ... 105% of n_{nom} P078 = 1 ... 100% of n_{nom}
1	P070 = 0.1 ... 10.5% of n_{nom} P078 = 0.1 ... 10.0% of n_{nom} The decimal point is not shown on the display!

Default value: 0**P 159****Cyclical error display**

S04.05 and above

If there is an error, the system automatically switches on the display and shows parameter P159 (S04.08 and above).

The stored errors are shown completely one after another.

The MODE key on the power converter is **not** effective.

The errors are retained and are not acknowledged by the display. Use parameter P005 (applies where P001 = 0 only) to acknowledge errors.

Parameters

P 160 * **n_{nom} limit mode**

Precontr. IA Val. menu, S04.12 and above

Range: 1 ... 2

Value	Meaning
1	Calculation of the maximum permissible speed at load measurement with constant power (hyperbola; $\text{load} \cdot n_{\text{per}} = \text{constant}$) Effective parameters: P133 ... P137 and P167
2	Calculation of the maximum permissible speed at load measurement on three straight sections (4 interpolation points). Effective parameters P133, P135 ... P137 and P161 ... P167

Default value: 1

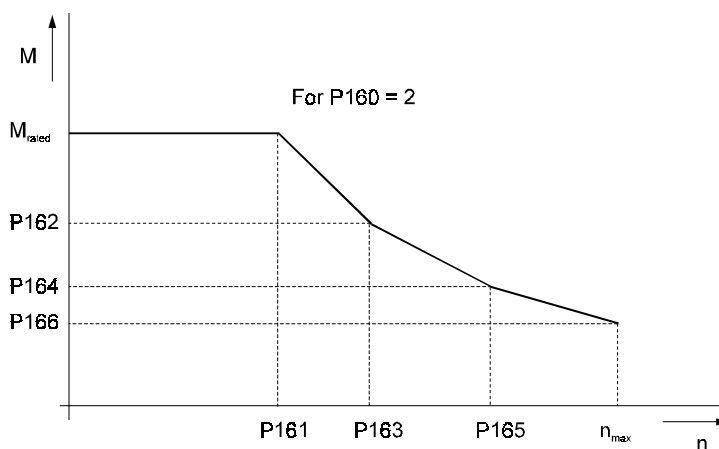

P 161 * **n-interpolation point 1**

Precontr. IA Val. menu
S04.12 and above

Speed interpolation point 1 up to which the system can run at maximum torque (maximum load). Is effective only when parameter P160 = 2.

Range: 25% ... 100%

Default value: 100%

P 162 * **M-interpolation point 2**

Precontr. IA Val. menu
S04.12 and above

The system runs at up to this torque on straight section 1. Is effective when parameter P160 = 2.

Range: 10% ... 100%

Default value: 100%

P 163 * **n–interpolation point 2** Precontr. IA Val. menu
S04.12 and above

Speed interpolation point 2 at up to which the system runs on straight section 1. Is effective when parameter P160 = 2.

Range: 25% ... 100%

Default value: 100%

P 164 * **M–interpolation point 3** Precontr. IA Val. menu
S04.12 and above

The system runs at up to this torque on straight section 2. Is effective when parameter P160 = 2.

Range: 10% ... 100%

Default value: 100%

P 165 * **n–interpolation point 3** Precontr. IA Val. menu
S04.12 and above

Speed interpolation point 3 at up to which the system runs on straight section 2. Is effective when parameter P160 = 2.

Range: 25% ... 100%

Default value: 100%

P 166 * **M–interpolation point 4** Precontr. IA Val. menu
S04.12 and above

Permissible torque at maximum speed. Is effective when parameter P160 = 2.

Range: 10% ... 100%

Default value: 100%

P 167

Base load

Precontr. IA Val. menu
S04.12 and above

This is needed to determine the acceleration factor, P133. If optimization run "6" (P081) is to be carried out with load (e.g. spreader), you must enter the appropriate value of the basic load (weight of spreader/rated load) before executing the optimization run. The value is not stored in the data set and is of no consequence during load measurement!

Example:

Weight of spreader	10 tonnes
Max. loading	40 tonnes
Rated load	50 tonnes
Basic load	10 t/50 t = 0.20
P167	20%

Range: 0% ... 100%

Default value: 0%

P 168

* Lower measuring limit

Precontr. IA Val. menu
S04.14 and above

This parameter is only effective if P136 = ON (load measurement ON).
The speed threshold from which onwards load measurement is active.

P160 = 1:

The **basic speed** results from the value of parameter P134 (field weakening range).
If you set P134 = 2.0, for example, the basic speed is 50% of the drive's maximum speed.

P160 = 2:

The **basic speed** is identical with the set value of parameter P161.

Range: 5% ... 50% of the basic speed

Default value: 20%

P 169

* Upper measuring limit

Precontr. IA Val. menu
S04.14 and above

This parameter is only effective if P136 = ON (load measurement ON).
The speed threshold up to which load measurement is active.
For the **basic speed**, see parameter P168.

Range: 50% ... 95% of the basic speed

Default value: 80%

P 170 * Frequency limit Precontr. IA Val. menu
S04.14 and above

Hardware output via supplementary module 3.9217 (Input/Output Expansion). If the mains frequency reaches the set value or exceeds it, output DA7 is set (X7b:13 on 3.9217). If the mains frequency falls below the set value, DA7 is reset. Typical pickup and release delays are around 60 ms. Can be used with operation of the power converter on a mains supply with a diesel generator.

Range: 45.0 Hz ... 65.0 Hz

Default value: 65.0 Hz

P 171 * Relay output K2 Monitoring menu
S04.14 and above

Range: 0 ... 1

Value	Meaning
0	n>n _x message. The switching threshold is specified with P070.
1	I _A ≥ I _x message. The switching threshold is specified with parameter P172 and refers to the maximum device output current (P025).

Default value: 0

P 172 * I_A ≥ I_x K2/1 Monitoring menu
S04.14 and above

The switching threshold refers to the maximum device output current (P025).

Range: 5% ... 120%

Default value: 95%

P 173 * Response time I_A ≥ I_x K2/1 Monitoring menu
S04.14 and above

The release delay is always 100 ms.

Range: 0.0 s ... 30.0 s

Default value: 1.0 s

Parameters

P 174 * **Linking relay K2/1 – K3/1**

Monitoring menu
S04.14 and above

Range: ON ... OFF

Value	Meaning
ON	Is only effective if relay K2 and relay K3 are assigned with function $I_A \geq I_x$ (P085 = 1 and P171 = 1). If the armature current exceeds the threshold set with P172 and the time set with P173 has expired, relay K3 also picks up after the time set with P175 has expired, even if the armature current does not reach the threshold set for K3 (P073). Condition: The threshold set for K2 (P172) must be less than the threshold for K3 (P073).
OFF	K2 and K3 switch independently of one another. This means that two separate current monitoring facilities are available.

Default value: OFF

P 175 * **Linking time relay K2/1 – K3/1**

Monitoring menu
S04.14 and above

For function, see parameter P174.

Range: 0 s ... 900 s

Default value: 60 s

P 00C **Software reset**

Ident./Control menu

If the PC or the controller writes (any value) to this parameter, the system **decelerates** the drive to speed = 0 and then triggers a reset.

P 01F * **Check sum BDS**

Ident./Control menu

Interrogation of the boot data set's checksum; the checksum is modulo 256. If no boot data set is present or it is faulty, a value greater than or equal to 256 is transferred as the checksum (for serial communication only).

P 07F * **Display parameters**

Ident./Control menu

Must be entered on the PC/controller.

Range: 0 ... 175

Default value: 1

9 MAINTENANCE



WARNING

This equipment carries a dangerously high voltage and has dangerous rotating parts (fans). Ignoring the safety and warning information may result in death, severe personal injury or damage to property.

You may only carry out maintenance and corrective maintenance work when the equipment is deenergized.

Do not begin work on the power stage and the connections until you have made sure that the system has been deenergized.

When dismantling safety equipment during commissioning, repair and maintenance work, you must ensure that the machine is taken out of commission in accordance with applicable regulations. You must remount and check safety equipment immediately after completing commissioning, repair and maintenance work.

After carrying out any work involving intervention in the machine – regardless of whether this involves the motor, the actual value acquisition or the power converter – the owner must carry out acceptance testing of the machine and document it chronologically in the machine log. Failure to do this may result in the owner being faced with consequences relating to liability legislation.

In addition, you should observe the warning information in the previous chapter.

When mounting and dismantling, you must never use force on the bus bars.

Use the provided lifting eyes when raising the power stages of size III and IV units.

If you have to change the fuses in size III and IV units, tighten the screws to the torque values shown below to ensure perfect contact:

M8 screw:	10 ... 13 Nm
M10 screw:	20 ... 26 Nm
M12 screw:	35 ... 46 Nm

Due to technical requirements, devices or motors may include individual components that contain dangerous substances.

You may only use manufacturer-approved spares.

We cannot guarantee that the product documentation is completely error-free unless this is expressly indicated in our General Conditions of Business and Supply.

9.1 Maintenance Information

The supplied units are maintenance-free.

Prohibition of Unauthorized Modifications

For safety reasons, unauthorized additions or modifications to the drive are not allowed.

NOTE

- Before touching the modules, you must discharge electrostatic energy from your body to protect electronic components from high voltages resulting from electrostatic charging. The easiest way to do this is to touch a grounded conductive object before handling components. Units containing components or modules at risk from electrostatic energy are clearly marked as such by the sticker below.

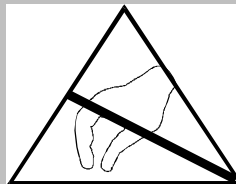

- Electronic components may not be touched by highly insulating materials such as man-made fibres from clothing, insulating mats or plastic sheeting/film. Always rest components on a conductive base.

9.2 Error Messages

LED H22 lights up red with a message or an error

All errors and messages are shown in numerical order in the error list. Errors numbered up to 99 result in a controller disable and main contactor off. Errors numbered 100 and above are messages that do not affect ongoing operation. In the case of a message or an error, the display shows the number via parameter P159.

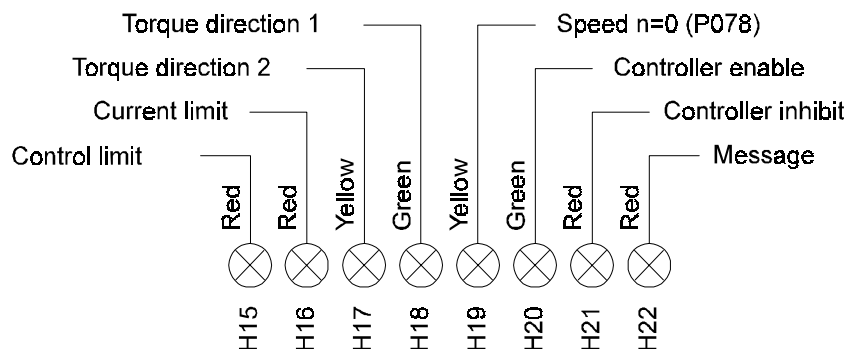

Meanings of operational and error displays

- H15 Control lights up red if the current controller is overloaded. In this case, the firing angle, α , is in the final position (α_G or α_W). H15 may only briefly light up when the speed changes and must never light up during operation!
- H16 The current limit lights up red if the speed controller is overloaded and the armature current I_A is
 $> 93\%$ of I_N
- H17 Torque direction 2 yellow
- H18 Torque direction 1 green
- H19 Lights up yellow with speed $n = 0$; parameter P078 determines the threshold
- H20 Lights up green with controller enable
- H21 Lights up red with controller inhibit
- H22 Message or error; apart from at the initialization stage, this only lights up red in the case of an operational disturbance; the display on the power converter shows via parameter P159 all the errors that have occurred, for error assignments, refer to the error list. Read off the individual error and clear it if necessary using parameter P005. On the PC, press function key F3 to display errors.
- H1 Red with STOP
- H2 Yellow with watchdog

- **Display of errors on the power converter's display**

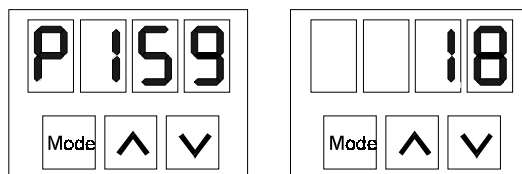

- **Display of all errors via parameter P159**

Cyclical display of all the errors that have occurred; they can be evaluated using the comments in the error list; if there is an error, the display switches on automatically (S04.08 and above) and shows parameter P159. Parameter 159 then shows all the errors one after the other. By contrast with parameter P005, it is not possible with P159 to clear errors by mistake (assuming that the error can be cleared at all).

The MODE key on the power converter is not effective! While the unit is switched-on, the errors are retained and are not acknowledged with the display. Use parameter P005 to acknowledge errors (applies when P001 = 0 only).

- **Reading an individual error via parameter P005**

Display of an error; using the keys, you can read, acknowledge and delete individual errors. To acknowledge the displayed error and display the next one: press the mode key and then one of the counter keys. The keypad must first have been enabled using P104 = 17.

Display of errors on the PC

Press F3: The error is displayed;

the system shows the status of the error on the bottom line of the menu and by means of LED H22 on the device, which lights up red if there is a message. You press F3 to acknowledge the message and return to the menu by pressing F10.

9.3 Error List

Error numbers 01 to 99 lead to a controller inhibit and an operational disturbance. As a result of the controller inhibit, the power converter is deenergized and the main contactor drops. This leads to the motor coasting to a standstill without being braked. You must take this into account with motion and lifting drives especially. After removing the error, a switching operation from 0 V \Rightarrow +24 V must take place at X1:22 to switch on the main contactor again.

This prevents the drive from automatically starting!

As a result of the operational disturbance signal, relay K1 "ready for use" drops for at least 1 second.

Error No.	Con- troller Inhibit	Opera- tional Dis- turbance	Description of Error	Effect/Action
00	No	No	Not an error	Normal operation
01	Yes	Yes	± 15 V disturbed or missing	Controller inhibit
02	Yes	Yes	Counterclockwise rotating field on power stage connection or power stage not connected (see also P007)	Controller enable not possible, deenergize the device, correct the power stage connection observe phase coincidence for feeding the control electronics
03	Yes	Yes	Synchronization with mains missing, possible loose contact in electronics supply	Control block is no longer synchronized with the mains, controller is disabled, controller enable no longer possible
04	Yes	Yes	Program watchdog has triggered	The system has not processed the controller program properly for the last 40 ms. Controller inhibit, H2 on PCB 3.8439 lit up (yellow LED) during a change of torque, the release time is 200 ms \Rightarrow RESET
05	Yes	Yes	Actual value of armature current negative several times; armature current acquisition faulty	Controller inhibit Controller reenable possible
06	Yes	Yes	Firing pulse interval different from specified value	Controller inhibit \Rightarrow RESET
07	Yes	Yes	Mains voltage out of range (rated mains connection voltage $\pm 20\%$)	Controller inhibit \Rightarrow RESET
08	–	–	Reserved	None
09	Yes	Yes	"End of Conversion" ADC signal missing (analog data acquisition faulty)	Controller inhibit Controller reenable possible
10	–	–	Reserved	None
11	–	–	Reserved	None
12	Yes	Yes	Armature voltage value wrong at $U_A = 0$ V (measured during booting)	No controller enable possible \Rightarrow RESET
13	–	–	Reserved	
14	Yes	Yes	Phase failure, mains or power unit not connected (measured at Main contactor ON)	Controller inhibit \Rightarrow RESET
15	–	–	Not assigned	None

RESET: Hardware reset or switch unit off and back on again

Error No.	Con- troller Inhibit	Opera- tional Dis- turbance	Description of Error	Effect/Action
16	Yes	Yes	The drive blocks if 1) P086 is set to ON 2) the drive runs at the current limit for longer than the time set using P087 and, during this time, 3) the speed set with P078 is continually fallen short of	Controller inhibit Controller reenable possible
17	Yes	Yes	Armature circuit open, armature not connected, armature circuit fuse has tripped, wrong speed standardization with tachometer control (P083 = 0/1)	Controller inhibit ⇒ RESET
18	Yes	Yes	Data traffic interrupted for longer than 1200 ms (in the case of serial communication, no data was exchanged during the last 1.2 s). It is assumed that there is an interruption in the connection between the computer/controller and the power converter; with P001 = 1/2/3	Controller inhibit Controller reenable possible, assuming that the connection is available again and all enables are at ON.
19	–	–	Not assigned	None
20	Yes	Yes	Mains frequency out of upper or lower measuring range $f < 44 \text{ Hz}$ or $f > 66 \text{ Hz}$	Controller inhibit ⇒ RESET
21	–	–	Reserved	None
22	–	–	Reserved	None
23	–	–	Reserved	None
24	Yes	Yes	Min. field current out of lower range (Field current $< 50\%$ of rated field current if no field weakening is set and field current $< 50\%$ of the minimum field current with field weakening)	Controller inhibit Controller reenable possible
25	–	–	Not assigned	None
26	–	–	Not assigned	None
27	Yes	Yes	Program execution disturbed	Controller inhibit ⇒ RESET
28	Yes	Yes	Hardware defect in digital section	Controller inhibit ⇒ RESET
29	Yes	Yes	Armature current 0 message disturbed/ defective (is acquired during booting; without a message, the system does not switch in torque direction TD1)	No controller enable ⇒ RESET
30	Yes	Yes	Armature current measurement offset error (is determined during booting, armature current measurement is disturbed or defective)	No controller enable ⇒ RESET
31	–	–	Reserved	None
32	–	–	Reserved	None
33	Yes	Yes	Overcurrent bridge 1 (TD1) Armature current actual value $> 2 \cdot$ rated value	Controller inhibit Controller enable possible
34	Yes	Yes	Overcurrent bridge 2 (TD2) Armature current actual value $> 2 \cdot$ rated value	Controller inhibit Controller enable possible

RESET: Hardware reset or switch unit off and back on again

Error No.	Con- troller Inhibit	Opera- tional Dis- turbance	Description of Error	Effect/Action
35	–	–	Not assigned	None
36	Yes	Yes	Signal for mains synchronization missing (e.g. plug X10 loose)	No controller enable ⇒ RESET
37	Yes	Yes	Interface X11 defective Ribbon cable missing or defective	No controller enable ⇒ RESET
38	Yes	Yes	Tachometer/encoder wire break No speed actual value signal with P083 = 0/1/2/3 or wrong I*R value (P020) or armature circuit open	Controller inhibit ⇒ RESET
39	Yes	Yes	Actual value polarity wrong; tachometer/encoder, field or armature connected wrongly with P083 = 0/1/2/3 or wrong I*R value	Controller inhibit ⇒ RESET
40	Yes	Yes	Tachometer offset error (is determined during booting, speed actual value measurement is disturbed or defective); e.g. RESET with rotating machine), with P083 = 0/1 only	No controller enable possible ⇒ RESET
41 S04.09 and above	Yes	Yes	Incremental encoder evaluation not available. Monitoring with controller structure P083 = 2/3 (at initialization of the power converter or data set loading only)	No controller enable possible ⇒ Fit daughterboard ⇒ RESET
42	Yes	Yes	EEPROM data set X is not from the same software group	Data set is unusable and is not loaded Generate a new data set and store it (P004)
43	–	–	Not assigned	
44	Yes	Yes	$n > 1.15 \cdot n_{rated}$, only with tachometer/encoder control P083 = 0/1/2/3 and error-free tachometer generator/encoder	Controller inhibit Controller reenable possible
45	Yes	Yes	Field connection not correct Field connection not available or not connected in-phase	No controller enable possible, deenergize the field device connection, correct the field device connection ⇒ RESET
46	Yes	Yes	Power stage connection not correct (phase sequence incorrect)	No controller enable possible, deenergize the device, correct the power stage connection
47 S04.11 and above	Yes	Yes	Daughterboard (3.9217) for parallel nominal value setting is not available. The system checks at initialization of the power converter or data set loading (P008) only.	No controller enable possible ⇒ Fit daughterboard ⇒ RESET
48	–	–	Not assigned	
49	Yes	Yes	EEPROM formatting faulty	No controller enable possible, data set is loaded from EPROM. EEPROM is unusable! Can be cleared with P109 (max. time for clearing = 10 s). After this, AUTO-RESET and formatting of the EEPROM. Communication source = 0. Generate new data sets
50	Yes	Yes	EEPROM not fitted or EEPROM storage area too small, error during EEPROM formatting	No controller enable possible, data set is loaded from EPROM (P109 possible, see error number 49)

RESET: Hardware reset or switch unit off and back on again

Error No.	Con- troller Inhibit	Opera- tional Dis- turbance	Description of Error	Effect/Action
51	Yes	Yes	Checksum or boot data set termination faulty	No controller enable possible, data set loaded from EPROM. (Generate new data set and store with P004)
52	Yes	Yes	EEPROM is not software-compatible EEPROM and program EEPROMs are not from the same software group	No controller enable possible data set loaded from EPROM (P109 possible, see error number 49)
53	Yes	Yes	Boot data set is not from the same software group	No controller enable possible, data set loaded from EPROM. Generate new data set and store with P004 ⇒ RESET
54	Yes	Yes	EEPROM boot data set is too long	No controller enable possible, data set loaded from EPROM (see error number 53) ⇒ RESET
55	Yes	Yes	EEPROM can not be cleared (after carrying out P109)	EEPROM is defective, fit a new EEPROM 2816 ⇒ RESET Generate data sets, specify the boot source
56	Yes	Yes	Boot source entry in EEPROM is outside range or not available	No controller enable possible, data set loaded from EPROM, possibly generate a new data set Enter boot source again with P006 ⇒ RESET
57	Yes	Yes	EEPROM data set X is too long (with P008 or when using P099/4)	Data set X is unusable and is not loaded, generate a new data set X and store it with P004
58	Yes	Yes	EEPROM data set X, checksum or data set termination not correct (with P008 or when using P099/4)	Data set X is unusable and is not loaded, generate a new data set X and store it with P004
59	Yes	Yes	EEPROM data set X is not available (with P008 or when using P099/4)	Selected data set X is not available controller inhibit, create a data set or load an existing one
60	–	–	Not assigned	None
61	Yes	Yes	No data set programmed	No controller enable possible, the system booted from the EPROM, generate a data set, enter the boot source
62	Yes	Yes	Device type is not software-compatible	EPROM "D5xx" is not suitable for the power converter type! Deenergize the device and fit new EPROMs
63	Yes	Yes	Individual EEPROM datum defective, P001, P006, P007, P009 have values that are outside the limits	Check the values of parameters P001/P006/P007/P009 and correct them if necessary ⇒ RESET
64	–	–	Not assigned	
65	–	–	Reserved	None
66	–	–	Reserved	None
67	–	–	Reserved	None
68	–	–	Not assigned	None
69	–	–	Not assigned	None

RESET: Hardware reset or switch unit off and back on again

Error No.	Con- troller Inhibit	Opera- tional Dis- turbance	Description of Error	Effect/Action
70	–	–	Not assigned	None
71	Yes	Yes	Phase difference 90° synchronous filter	Hardware defect on V31 PCB 3.8934 or mains disturbance Enable not possible
72	Yes	Yes	PC software and power converter software not compatible	Use PC software from the same software group. No enable possible
73	Yes	Yes	PC data file and power converter software not compatible	Use PC software from the same software group (data file *.68K), no enable possible
74	Yes	Yes	Communication source outside range	Reprogram communication source (P001) no enable possible ⇒ RESET
75	–	–	Not assigned	None
76	Yes	Yes	Timeout exceeded programming individual datum	Reprogram parameters P001 or P006 or P007 or P009, no enable possible
78 S04.23 and above	Yes	Yes	RAM defective	
100	–	–	Power stage detection not possible	None, display cannot be used with P000, check device type P139
101	–	–	Power stage detection of field device not possible	None, display cannot be used with P119
102	–	–	Ripple limit cannot be determined (with optimization run 1 or 4.1) device current or current limit too low	Default value = 30% Current precontrolling not working correctly
103	–	–	Armature circuit inductivity cannot be determined with optimization run 1 or 4.1 Possibly P037 = 0.00	Suboptimal current precontrolling, probable armature current overshoot, default value = 0
104	–	–	Motorized potentiometer memory value unusable (with P099/3)	Motorized potentiometer value is set to 0! Enable possible, store value again
105	–	–	Temperature of motor has exceeded the set threshold (I ² t monitoring)	Operation can continue for another five minutes at the most, the equipment must then be turned off. For relay K4, see function P128. The operator must respond
106	–	–	Mains frequency is outside the range of 47 Hz < f < 63 Hz, the power converter can still function	None
107	–	–	Temperature of heat sink in the power stage > 85° C	Temperature of power stage too high; operation can continue for another five minutes at the most, the equipment must then be turned off. For relay K4, see function P128. The operator must respond
108	–	–	Temperature measurement of the heat sink in the power stage not possible	Relay K4 picks up, The operator must respond
109	–	–	Verify error on data set programming with P004 = 1/2/3/4	Data set programming was cancelled The system marks the data set as not available
110	–	–	Data set programming cancelled due to timeout being exceeded (max. of 5 s with P004 = 1/2/3/4)	Data set is not transferred and is marked as not available

RESET: Hardware reset or switch unit off and back on again

Error No.	Con- troller Inhibit	Opera- tional Dis- turbance	Description of Error	Effect/Action
111	–	–	Boot source entry is invalid	Selected data set is not available (with P006)
112	–	–	EEPROM data set was not programmed (data set not saved)	Programming not carried out because – drive is not inhibited or – optimization run is selected or – data set is being loaded or – data set is still being programmed
113	–	–	EEPROM data set was not loaded (P008 or P099/4)	Data set was not loaded because optimization run is selected, or EEPROM is just being programmed or a previous "Load data set" has not yet been completed
114	–	–	Acceleration factor cannot be determined (P081 = 6/P136 = ON)	Speed change = 0 or acceleration current is less than 1% of the rated current. Set a shorter ramp-up time on the integrator or set the nominal value lower than the basic speed.
115	–	–	Entered maximum speed (P142) for selected rotary encoder (P143) is too high.	Power converter limited the input value of parameter P142.

9.4 Spares

9.4.1 Modules and Complete Units

Power converters BKF12 or BKD6 comprise the following modules:

Open- and closed-loop control unit PCB 3.8934..	
Field supply and mains unit	BKF N 400F 400R for 400-V connection voltage Field XX.A or BKF N 500F 500R for 500-V connection voltage Field XX.A
Power stage	No. 933 14 765 J (example)
Housing and assembly parts	

Simply stating the module is not enough to ensure that the correct spares are delivered!

You must therefore state in addition:

the machine manufacturer

the type designation and the serial number of the power converter

You can find this information on the rating plate on the inside of the housing

Example of a rating plate:

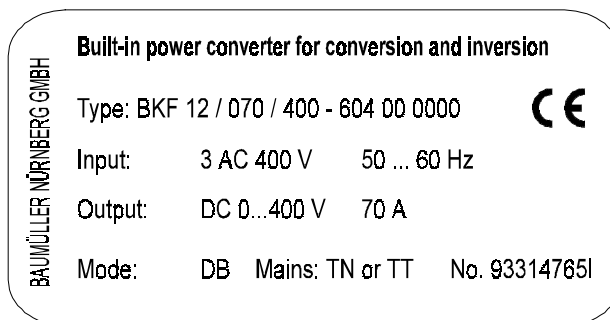

For delivery of a complete replacement unit, you only need to state type BKF... or BKD..., the serial number, the desired software version and the amperage of the field device.

9.4.2 Replacement boards, Daughterboards and Individual Parts

NOTE

In principle, the use of replacement boards is possible but is not without problems if you do not observe the handling regulations for components at risk from electrostatic charges (EGB)!

Boards for power converters BKF or BKD:

Open- and closed-loop control unit	PCB 3.8934
Field supply XX.A	PCB 3.8942

the latest version of the board is always supplied

Individual parts for power converters BKF or BKD:

Current converter	See technical data of power stage
Fan	See technical data of power stage
Fuses	See semiconductor fuses
Cover plate for closed-loop control subassembly	Order no. 319009335
Cover plate for power stage	Order no. 319009336
2-pin sub-unit terminal	Order no. 319012811
8-pin sub-unit terminal	Order no. 319012809
12-pin sub-unit terminal	Order no. 319009064

Add-on boards for power converters BKF or BKD:

Input/output expansion	PCB 3.9217
Dual DAC 12	PCB 3.9201
InterBus-S	PCB 3.9208
RS232 and RS485 interfaces	PCB 3.8947
RS485 interface for CS31 system bus or with USS protocol	PCB 3.9493

Accessories for add-on boards:

Spacer bolt	Order no. 19009808
Cover plate for open- and closed-loop control unit	Order no. 19009339
64-pin ribbon cable	Order no. 19017794

Simply stating the module is not enough to ensure that the correct spares are delivered!

You must therefore state in addition:

the machine manufacturer

the type designation and the serial number of the power converter

You can find this information on the rating plate on the inside of the housing

9.5 Disposal

For the most part, the equipment consists of the following components and materials:

Component	Material
Housing, various intermediate panels, fan impeller, mounting panels	Sheet steel
Heat sink in the power stage	Aluminium
Various spacer bolts	Steel
Various spacers, housing of current converter and unit fan, etc.	Plastic
Bus bars in the power stage	Copper
Cable harnesses	PVC-insulated copper wire
Power electronics: Module thyristors mounted on a heat sink	Metal base plate, semiconductor chip, plastic housing, various insulation materials
PCBs on which all the open- and closed-loop electronics are mounted	Base material: Epoxy-resin fibreglass woven material, copper-coated on both sides and plated-through, various electronic components such as condensers, resistors, relays, semiconductors, etc.

For technical reasons, electronic components might need to contain dangerous materials, so you should not open them.

If the components are used correctly, there is no danger to human beings or to the environment.

In case of fire, dangerous compounds may result or hazardous materials may be released.

You must dispose of or recycle equipment or components according to national regulations as well as any applicable local or regional ordinances.

10 APPENDIX

10.1 Complementary Documentation

As of 09/95

Title	Document No.	Edition Dated
Regelbare Antriebssysteme, Steuerungen, Dienstleistungen 1995	2.095	01/95
EMV-Applikation für Umrichterantriebe	5.95098.01	03/95
Technische Beschreibung InterBus-S für BKF/BKD Serie 6000	5.93011.01	05/93
Technische Beschreibung Schnittstellenkarte RS232 / RS485 zum BKF/BKD Serie 6000	5.93013.01	08/93
Technische Beschreibung Schnittstellenkarte RS485 als CS31-Systembusanschaltung für BKF/BKD Serie 6000	5.95078.01	09/95
Technische Beschreibung Schnittstellenkarte RS485 mit USS-Protokoll für BKF/BKD Serie 6000	5.95223.01	09/95
Technische Beschreibung Netzfilter für Baumüller Leistungselektronik BFN	5.95237.01	10/95

10.2 Manufacturer Declaration

Manufacturer Declaration in Accordance with the EC–Machine Guidelines 89/392/EEC, Appendix II B

We herewith declare that this delivery includes the following specified machine component and that its putting into operation is prohibited until the declaration is made that the machine, in which this component is built in, complies with the regulations of the EC–machine guideline 89/392/EEG, appendix II B.

Specification of the machine component:

Type:

Built-in Power Converter for Conversion and Inversion

BKF 12/.../...–6.....

BKD 6/.../...–6.....

Date/Signature of the Manufacturer:



Information regarding the Undersigned:

Head Division Electronics

10.3 Declaration of Conformity

**EG Declaration of conformity
of equipment regarding
low voltage directive 73/23/EWG**

Specification of the machine component:

Type:

Built-in Power Converter for Conversion and Inversion

BKF 12/.../...-6.....

BKD 6/.../...-6.....

Conformity of the signficated product with the guidelines will be proved by following rules:

pr EN 50178: 1994 (VDE 0160/11.94)

"Equipment of power installation concerned electronic operating materials"

Nürnberg, 10. January 1996

Signature of the Manufacturer



Dr.-Ing. P. Kreisfeld

Head Division Electronics



Dipl.-Ing. (FH) R.-A. Geller

CE-Agent Electronic

10.4 Conditions of Business and Delivery

1. Scope
 - 1.1 Deliveries and performance provided by Baumüller and offers made by Baumüller are exclusively and completely subject to these general terms and conditions (from now on referred to as "these terms"). Unless a mutual agreement has been made which differs from this statement, these terms also apply to future business relationships. 1.2 If a customer places an order with Baumüller, this implies that these terms are accepted. Any counterofferations made by persons or legal persons placing an order with Baumüller with reference to their own general terms and conditions or their terms and conditions of purchase are hereby objected to.
 - 1.3 Supplements or modifications to these terms require written consent from Baumüller in order to take effect.
 2. Offer and Copyright
 - 2.1 Offers made by Baumüller are subject to confirmation and not binding. Supplements, modifications or ancillary agreements require written consent from Baumüller in order to take effect.
 - 2.2 Any pictures, drawings, measures, weights or other performance specifications are only binding if this is explicitly stipulated in writing. Drawings, dimensional drawings and descriptions of projects are subject to the copyright of Baumüller and must neither be copied nor revealed to third parties without prior written consent from Baumüller. Baumüller reserves the right to demand that these objects are immediately returned to Baumüller if they are not used for orders to Baumüller.
 - 2.3 The purchaser must not use any process engineering knowledge revealed to him in his business relationship with Baumüller for his own purposes and must not reveal that knowledge to third parties. Any violation of this condition makes the purchaser (violation) liable for damages of an amount of DM 70,000.-
 3. Scope and Term of Delivery
 - 3.1 The deadlines and terms specified by Baumüller are not binding unless explicitly specified otherwise in a written agreement.
 - 3.2 The delivery term begins at one of the points in time listed below:
 - Date of confirmation of order
 - Date on which the purchaser meets all of the technical, commercial or other prerequisites he is obliged to meet
 - Date on which a down-payment or security required prior to delivery of the merchandise is furnished by the purchaser
 If the stipulated down-payments to Baumüller are made delayed, the delivery term is extended proportionally.
 - 3.3 Baumüller has the right to make partial deliveries and provide partial performance and to issue partial invoices for these deliveries or performance at any time of their choice. Excess volume or short deliveries up to 5% of the delivery quantity are permitted. The amount charged is calculated according to the delivery quantity.
 - 3.4 Baumüller is not responsible for delayed delivery or performance or the inability to deliver or perform due to acts of god or force majeure or other events which make it impossible or more difficult for Baumüller to deliver - e.g. war, problems in the provision of materials which arise after the time the offer has been made, malfunctions, strike, lockout, personnel shortage, shortages of means of transportations, instructions issued by the authorities etc. which occur at suppliers of Baumüller or their sub-suppliers. Therefore, Baumüller has the right to postpone deliveries or performance by the duration of the problem plus an appropriate start-up time and Baumüller also has the right to withdraw from the contract partially or completely. If the problems persist for more than 3 months the purchaser has the right to withdraw from that part of the contract which has not yet been fulfilled after having fixed an appropriate extension of the time limit.
 - 3.5 The deadline is considered to have been met if the object to be delivered leaves the storage facility on the fixed date or if the purchaser is informed of its availability for shipment on the fixed date.
 - 3.6 Baumüller or subcontractors of Baumüller will install and assemble the delivered objects exclusively subject to conditions and terms separately agreed upon not later than 4 weeks before delivery.
 4. Passage of risk, acceptance, packing
 - 4.1 Delivery is made free carrier (FRC, INCOTERM 1980). The goods are packed at the discretion of Baumüller at the costs of the customer. The risk is passed to the customer as soon as the consignment has been handed over to the person carrying out the transport or has left the store.
 - 4.2 If the shipment is delayed or becomes impossible due to reasons for which Baumüller is not responsible, the risk is passed to the customer with the notification of readiness for shipment if the delivery is stipulated to be carried out upon call-forward notice, the goods are regarded as called off at the latest one year after the date of order.
 - 4.3 Special acceptance conditions must be defined at conclusion of the contract at the latest. The acceptance test has to take place in the works of Baumüller. The costs for the acceptance test will be charged to the customer. If the customer omits the acceptance test, the goods are regarded as delivered as stipulated when they leave our works.
 5. Prices and terms of payment
 - 5.1 The prices stipulated by Baumüller in the order confirmation plus the respective legal value added tax apply. Additional deliveries and services will be separately invoiced. The prices are valid ex works or store excluding packing.
 - 5.2 If not otherwise agreed upon, the prices stipulated in the order confirmation are binding for 30 days only.
 - 5.3 Payments shall be made in cash without any deductions free paying office of the vendor in the currency agreed upon. Bills of exchange and checks are only accepted on account of payment. The customer has to bear any costs and bank charges arising therefor. A payment is regarded as made only, if the amount is available to Baumüller. In case of payment by check, the payment is regarded as made, when the check has been irrevocably cashed.
 - 5.4 Invoices are to be paid without deductions within 30 days from the date of issue. Baumüller is entitled to enter payments of the customer on older open invoices in spite of deviating instructions by the customer. If costs and interests have already arisen, Baumüller is entitled to enter the payment first on the costs, then on the interests and last on the main service.
 - 5.5 The customer is entitled to offset, to retain or reduce the payment - independent of notices of complaint or possible counterclaims - only, if Baumüller has explicitly agreed or if the counterclaims have been legally verified.
 - 5.6 If payments are delayed, Baumüller is entitled to charge interest on arrears at a rate corresponding to the interest rate for open credits in current account, however, at least corresponding to the current discount rate of the Deutsche Bundesbank. This does not affect the assertion of another damage caused by delayed payment.
 - 5.7 If the customer fails to meet his payment obligations, especially if he does not cash a check or stops his payment or if Baumüller is informed of other circumstances making the credit worthiness of the customer uncertain, Baumüller is entitled to demand advance payments or securities before delivery or to invoice the total remaining amount in the case that instalments had been previously agreed upon.
 6. Retention of ownership
 - 6.1 Until all claims for present or future relations have been satisfied, Baumüller can at any time demand securities from the customer. Baumüller will arbitrarily release provided securities, if the value of the securities lastingly exceeds the claims by more than 20 %.
 - 6.2 Any goods delivered remain property of Baumüller until payment has been made in full (=delivery under proviso). Goods delivered under proviso are processed or reconfigured at the purchaser's for Baumüller as the manufacturer but without additional obligations. If Baumüller ownership rights are nullified because the goods are integrated into or assembled to other objects, a portion of the ownership rights of the purchaser to that object covering the amount in question is transferred to Baumüller. The purchaser keeps the property of Baumüller in custody for no charges.
 - 6.3 The purchaser has - unless he is in delay of payment - the right to process and sell the goods delivered under proviso in normal business. However, he must not distress or transfer ownership of the goods delivered under proviso by way of security. The purchaser transfers any receivables arising from the selling of the goods or from another legal reason completely to Baumüller when the goods are received. Baumüller revokably entitles the purchaser to collect the receivables transferred to Baumüller on the account of Baumüller under his own name. Upon request by Baumüller, the purchaser will reveal the transfer.
 - 6.4 If third parties access the goods delivered under proviso, the purchaser will inform them about the ownership rights of Baumüller and will immediately inform Baumüller. Any expenses and damages are paid for by the purchaser.
 - 6.5 If the purchaser violates any of the terms of the contract - in particular if he is in delay of payment - Baumüller has the right to repossess the goods delivered under proviso at the cost of the purchaser or Baumüller has the right to require transfer of the restitution title the purchaser has against third parties. If Baumüller repossesses or distresses the goods delivered under proviso, this does not mean that Baumüller withdraws from the contract. The right to receive payment for damages remains unaffected by this.
 7. Warranty
 - 7.1 If the delivered products are faulty or fail to have properties guaranteed by Baumüller or if the products become defective during the warranty period because of faults which occurred or were caused during the process of manufacturing or in case of material defects Baumüller supplies - excluding any other warranty claims by the purchaser, in particular excluding any direct or indirect secondary claims for damages from the purchaser - replacement parts of their own choice or rectifies defects. Multiple rectification is permitted. For essential products and parts not manufactured by Baumüller - in particular if the purchaser has made specifications - the liability of Baumüller is limited to the transfer of the claims for damages Baumüller has against the supplier of these products or parts.
 - 7.2 The warranty period is 12 months and starts the day the goods are shipped to the purchaser or - if the delivery scope is installed and assembled by Baumüller - the warranty period starts on the day the installation is complete.
 - 7.3 The purchaser is obliged to inspect the delivered goods for damages or defects immediately or at least within two weeks after receiving the goods or - if the product is installed - within two weeks after completion of the installation process. In addition, he is obliged to inform Baumüller of any damages, defects or losses immediately by sending an report created by the carrier or a corresponding report in the form of a statement in lieu of an oath which must have been signed by two witnesses and by the purchaser. In addition, Baumüller must be informed in writing of obvious defects or shortcomings immediately or at least within two weeks after delivery. If shortcomings and defects cannot be detected in thorough tests within two weeks and are found at a later time, Baumüller must be informed of these problems immediately after they are detected. Defective products must be submitted to Baumüller for testing on request in the condition in which the defect was detected. Defective products must not be returned to Baumüller unless Baumüller requests in writing that the products are returned. Failure to observe any of the regulations specified above nullifies all warranty claims against Baumüller.
 - 7.4 If rectification or replacements is not successful within an appropriate period of time, the purchaser may either request reduction of the purchase price or cancellation of the delivery contract.
 - 7.5 If Baumüller manufactures a product based on design specifications, drawings, models or other specifications provided by the purchaser, Baumüller is responsible only for the fact that the manufactured product meets the specifications. Baumüller is not responsible for the usability of the product for the purposes the purchaser intends to use it for.
 - 7.6 Excluded from warranty are shortcomings or defects caused by instructions and/or assembly not effected by Baumüller, insufficient equipment of the customer, overload of the components exceeding the capacity specified by Baumüller, negligent and improper treatment and utilization of unsuitable operating materials at the customer. This also applies to shortcomings or defects arising due to material provided by the customer. The warranty does not apply to damages caused by third parties, atmospheric discharges, overvoltages and chemical influences or to the replacement of parts which are exposed to natural wear.
- The warranty is void if the customer or a third party changes or repairs the units delivered without written permit by Baumüller.
- 7.7 In case of guarantee and/or warranty claims, the motor, the spare part or the unit shall be shipped free of duty and with free packing after prior agreement with Baumüller. Baumüller is freed of any warranty, if the customer returns the defective products without prior agreement or without observing the arrangements.
 - 7.8 Baumüller is entitled to install spare parts and units into the plants of the customer for warranties to be fulfilled within the warranty period, in order to replace the defective products so that the efficiency of the customer's parts is affected as little as possible. The warranty period for installed spare parts and units is 6 months from the date of replacement at the customer. Taking into account the service time for the delivered products, the warranty period of 12 months from date of delivery, acc. to item 7.2, remains unchanged.
 8. Liability
 - 8.1 Baumüller is liable for information and consulting activities on the utilization of the ordered and delivered products only with written confirmation in accordance with the below regulations. Verbal statements and information are not binding.
 - 8.2 Claims for damages due to impossibility of performance, nondelivery, positive breach of obligations, culpa in contrahendo and unlawful act to Baumüller as well as to the persons employed in performing an obligation are excluded, if the damage has not been caused deliberately or grossly negligent or Baumüller is liable according to the product liability law.
 9. Lump-sum damages in case of withdrawal
 - 9.1 If the customer withdraws from the written order due to reasons for which Baumüller is not responsible, Baumüller is entitled to charge lump-sum damages of 50 % of the net order amount. This applies also, if Baumüller withdraws from the contract due to reasons for which the customer is responsible.
 10. Miscellaneous
 - 10.1 Place of fulfillment and jurisdiction is Nuremberg. However, Baumüller is entitled to advance claims at the legal place of jurisdiction of the customer.
 - 10.2 The legal regulations applicable in the Federal Republic of Germany are applicable to these conditions and terms of sales and delivery. The regulations or the UN law of sales are excluded.
 - 10.3 If one or several regulations of these conditions and terms of sales and delivery are or become ineffective or if any arising situation and circumstances are not covered by this contract text, jurisdiction will replace or supplement the ineffective or incomplete stipulations by appropriate regulations corresponding to the economic purpose of the intended regulation to the largest possible extent. The validity of the other regulations remains unchanged.

10.5 Index

A

Acceleration Factor • 239
 Accessories • 103
 Actual value bar • 179
 Analog output • 19, 227
 Armature Current Monitoring • 123; 125
 Automatic Restart • 148

B

Base Load • 248
 Boot Data Set • 250
 Bus Bars • 251

C

C17 • 28; 30
 Checksum • 250
 Commissioning • 157
 Commissioning Guidelines • 182
 Conditions of Business and Delivery • 268
 Configuration Record • 196
 Connection Voltage • 10; 13; 14; 16
 Consumed Power • 220
 Control unit • 107
 Controller Enable • 136; 138
 Controlling • 133
 CS31 System Bus Interface • 25
 Current Control • 113
 Current controller • 107
 Current limiting, speed-dependent • 120
 Current Limits • 119
 Current Precontrol • 215
 Current Transformer • 16

D

Delay • 236
 Device Type • 240
 Dimensions • 10; 44
 Disabling • 133
 Display • 161, 231
 Display data set • 238
 Displaying Relay Functions • 129
 Disposal • 263
 Drive inhibit function • 236
 Drive Ready to Start • 126
 Dual DAC 12 • 21, 84

E

Enabling the keypad • 162
 Equipment Set-Up • 190
 Error Messages • 253

F

Fan • 16; 39; 40
 Fast Brake • 136; 138; 147, 236
 Field Current Monitoring • 126
 Field Failure Protection • 13
 Field Power Converter • 13
 Field Weakening Control Unit • 39; 40
 Field Weakness Control • 13
 Functions • 105

G

Gapping current limit • 212

H

Handling • 162
 Header • 169; 178
 Higher Key • 162
 Humidity Rating • 10
 Hysteresis • 235

I

$I \times R$ • 212
 I_{A} Monitoring • 127
 $I_{\text{A}} > I_{\text{X}}$ • 221
 Inching • 117
 Initial Commissioning • 158
 Installation • 57
 Integ.-act. time UA controller • 216
 InterBus-S • 23, 90

K

Keypad • 161
 Keypad enable • 231

L

Line Commutators • 100
 Line Reactors • 13
 Linking Relays • 126
 Lower Key • 162

M

Main Contactor Edge • 222
 Main Contactor ON • 138; 147
 Mains Connection Voltage • 15
 Mains Frequency • 10; 13; 14; 15; 16
 Mains Unit • 39; 40
 Mains Voltage Tolerance • 10; 13; 14; 15; 16
 Maintenance • 251
 Maintenance Information • 252
 Manufacturer Declaration • 266
 Measuring channel • 227
 Mode key • 161
 Multiplier • 245

N

n-Interpolation Point • 246
n < n_x for Fast Brake • 222
Nominal DC Current • 10
Nominal DC Voltage, Field • 13
Nominal Direct Voltage • 39; 40
Nominal Value Setting • 105
Nominal Value Source • 114

O

Online Operation • 176
Operating Status Conditions • 20
Operating temperature range • 10; 13
Operation • 160; 165

P

P106 • 139
P106 • 232
P107 • 233
P108 • 142
P108 • 233
P129 • 238
Parameter Documentation • 197
Parameter List • 207
Parameters • 207
PC Interfaces • 165
Power Losses • 26
Power Stage • 207, 39
Programmable Analog Input • 225
Programmable Input • 18
Pulse Inhibit • 138

R

R100 • 28; 30
R102 • 28; 30
R103 • 28; 30
Rating Plate • 182
Read single error • 208
Reading an individual error • 254
Reduced Field • 221
Relay • 17
Relay K2 • 123
Relay K4 • 127
Relay output K2, programming • 249
Release Point • 13
Replacement boards • 262
Rotating field • 208
RS 232, RS 485 • 91
RS232, RS485 • 24
RS485 with USS protocol • 25

S

Safety Facilities • 158
Scaling • 240
Semiconductor Fuses • 13
Software Version • 208
Speed Actual Value • 19, 219
Speed controller • 106
Speed Monitoring • 123; 125
Speed Nominal value Source • 18
Speed range • 11
Starting Current Inrush • 151
Stock-Taking • 182
Storage and Transportation Temperature • 10
Switch-Off Sequence • 147
Switching inputs • 17

T

Technical Data
Timeout • 243
Trafoanschlüsse • 34
Transformer Connections • 36

U

User Programs • 165

W

W11 • 28; 30
W13 • 30
W20 • 28
Weight • 10

Z

Zero Speed Field • 13