

2127661

Revision 9

LOGIQ™ 400
Service Manual

Copyright © 1995, 1996, 1997, 1998, 1999, 2000 by General Electric Company

LIST OF EFFECTIVE PAGES

REV	DATE	PRIMARY REASON FOR CHANGE
0	July 27, 1995	Initial release
1	October 6, 1995	Software version 2.10 release, error correction
2	July 10, 1996	Software version 3.00 release, error correction
3	March 10, 1997	Software version 3.10 release, error correction
4	December 17, 1997	LOGIQ™ 400CL release, error correction
5	June 19, 1998	Software version 3.40 and 3.41 for LOGIQ™ 400CL release and error correction
6	April 21, 1999	Software version 4.01y and 4.02y release and error correction
7	September 17, 1999	Additional information for SGMS Manufacturing
8	October 15, 1999	Software version 4.31y and 4.32y release and error correction
9	March 17, 2000	Software version 5.01 release and error correction

PAGE	REV	PAGE	REV	PAGE	REV	PAGE	REV	PAGE	REV
Title page	9	2-2 to 2-4	0	4-8 to 4-10	1	5-8 to 5-9	9	Chapter 8	
GE Logo page	-	2-5	5	4-11 to 4-13	0	5-10 to 5-11	6	8-1 to 8-3	5
P9030CB	2	2-6 to 2-9	0	4-14	1	5-12 to 5-13	0	8-4	0
P9030CC	4	2-10	9	4-15	0	5-14 to 5-15	2	8-5 to 8-7	5
P9030CD	0	2-11 to 2-16	0	4-16	6	5-16 to 5-17	6	8-8 to 8-15	0
A	9			4-17	0	5-18	9	8-16	5
i	8	Chapter 3		4-18	5	5-19	8	8-17	0
ii to x	9	3-1	9	4-19	1	5-20	9	8-18	5
Chapter 1		3-2	0	4-20 to 4-24	5			8-19 to 8-20	4
1-1	8	3-3 to 3-16	9	4-25 to 4-26	9	Chapter 6		8-21	5
1-2 to 1-3	0			4-27 to 4-32	5	6-1 to 6-288	9	8-22	0
1-4	2	Chapter 4		4-33 to 4-46	6			8-23	5
1-5 to 1-8	8	4-1	6	Chapter 5		Chapter 7		8-24	0
1-9	7	4-2	0	5-1	6	7-1	5	8-25 to 8-26	5
1-10 to 20	8	4-3	2	5-2	0	7-2	0	8-27	0
Chapter 2		4-4	1	5-3 to 5-4	1	7-3	4	8-28	5
2-1	5	4-5	0	5-5	9	7-4 to 7-6	2	8-29	0
		4-6	1	5-6 to 5-7	6	7-7 to 7-20	5	8-30 to 8-88	5
		4-7	0						

TABLE OF CONTENTS

SECTION	TITLE	PAGE
	TABLE OF CONTENTS	i
CHAPTER 1 – INTRODUCTION		
1-1	SERVICE MANUAL CONTENTS	1-3
1-2	SAFETY	1-4
	1-2-1 Warnings	1-4
	1-2-2 Specifications	1-17
1-3	EMC (Electromagnetic Compatibility)	1-18
	1-3-1 EMC Performance	1-18
	1-3-2 Notice upon Installation of Product	1-18
	1-3-3 General Notice	1-19
	1-3-4 Countermeasures against EMC-related Issues	1-19
	1-3-5 Notice on Service	1-19
1-4	ADDRESS	1-20
CHAPTER 2 – INSTALLATION		
2-1	PREINSTALLATION	2-3
	2-1-1 Introduction	2-3
	2-1-2 Power Line Requirements	2-3
	2-1-3 Physical Specifications	2-4
	2-1-4 Recommended Ultrasound Room Layout	2-5
2-2	INSTALLATION	2-8
	2-2-1 Introduction	2-8
	2-2-2 Average Installation Time	2-8
	2-2-3 Installation Warnings	2-8
	2-2-4 Checking the Components	2-8
	2-2-5 Unpacking LOGIQ™ 400	2-9
	2-2-6 Probe Cable Arm Installation	2-12
	2-2-7 MTZ Probe Holder Installation	2-13
	2-2-8 Transducer Connection	2-13
	2-2-9 Powering-Up Procedure	2-14
	2-2-10 Moving into Position	2-15
	2-2-11 Adjusting System Clock	2-15
	2-2-12 Product Locator Installation Card	2-16

SECTION	TITLE	PAGE
---------	-------	------

CHAPTER 3 – SYSTEM CONFIGURATION

3-1	INTRODUCTION	3-3
3-2	DIMENSIONS	3-3
3-3	ELECTRICAL SPECIFICATIONS	3-6
3-3-1	Power Supply	3-6
3-3-2	Facility Power Receptacle	3-6
3-4	STORAGE AND OPERATION REQUIREMENTS	3-6
3-5	OPTIONAL PERIPHERALS	3-7
3-5-1	Peripherals/Accessories Connector Panel	3-7
3-5-2	List of Optional Peripherals	3-11
3-5-3	Power Consumption of Optional Peripherals	3-15
3-6	VIDEO SPECIFICATIONS	3-16

CHAPTER 4 – FUNCTIONAL CHECKS

4-1	INTRODUCTION	4-3
4-1-1	Required Equipment	4-3
4-2	FUNCTIONAL CHECK PROCEDURES	4-4
4-2-1	Basic Controls	4-4
4-3	DIAGNOSTICS	4-10
4-3-1	Service Software Menu	4-10
4-3-2	Diagnosis Test Menu	4-11
4-3-3	Utility Menu	4-16
4-4	POWER SUPPLY ADJUSTMENTS	4-37
4-4-1	Power Supply Access	4-38
4-4-2	Power Supply Adjustment Procedure	4-40

CHAPTER 5 – DIAGRAMS

5-1	INTRODUCTION	5-3
5-2	LOGIQ™ 400 SYSTEM	5-3
5-3	BLOCK DIAGRAM	5-4
5-4	WIRING DIAGRAM	5-8
5-5	POWER SUPPLY BLOCK DIAGRAM	5-12
5-6	POWER SUPPLY2 BLOCK DIAGRAM	5-14
5-7	POWER SUPPLY2 BLOCK DIAGRAM	5-16
5-8	CIRCUIT BOARD DESCRIPTION	5-18

SECTION	TITLE	PAGE
---------	-------	------

CHAPTER 6 – RENEWAL PARTS

6-1	RENEWAL PARTS	6-7
6-2	DISASSEMBLY/RE-ASSEMBLY	6-69
6-2-1	Monitor Assy (FRU No. 100)	6-70
6-2-2	Monitor Cover Set (FRU No. 101)	6-72
6-2-3	Escutcheon Latch (FRU No. 103)	6-76
6-2-4	Escutcheon Front Door (FRU No. 107)	6-77
6-2-5	CRT Cap Set (FRU No. 108)	6-78
6-2-6	CRT Filter (FRU No. 109), CRT Filter Clamp Set (FRU No. 110)	6-79
6-2-7	Accessory Assy (FRU No. 111)	6-80
6-2-8	Speaker Assy (FRU No. 112)	6-82
6-2-9	CRT Lamp Assy (FRU No. 113), CRT Lamp (FRU No. 114)	6-84
6-2-10	CRT Assy (FRU No. 115)	6-86
6-2-11	CRT Cable Set (FRU No. 116)	6-88
6-2-12	Monitor Assy NTSC (FRU No. 150), Monitor Assy PAL (FRU No. 151)	6-90
6-2-13	Monitor Cover (FRU No. 152)	6-92
6-2-14	Escutcheon Assy (FRU No. 153)	6-93
6-2-15	Fixing Metal Plate (FRU No. 154)	6-96
6-2-16	CRT Filter (FRU No. 155), CRT Filter Clamp Set (FRU No. 156)	6-97
6-2-17	Monitor Bottom Assy (FRU No. 157)	6-98
6-2-18	CRT Assy NTSC (FRU No. 158), CRT Assy PAL (FRU No. 159)	6-100
6-2-19	CRT Cable Set (FRU No. 160)	6-102
6-2-20	CRT Lamp (FRU No. 161)	6-103
6-2-21	Monitor15 Assy (FRU No. 170)	6-104
6-2-22	Monitor15 Cover Set (FRU No. 171)	6-106
6-2-23	Speaker Assy (FRU No. 178)	6-109
6-2-24	Task Lamp (FRU No. 180)	6-110
6-2-25	CRT Cable Set (FRU No. 182)	6-111
6-2-26	Neck Assy (FRU No. 201 for Color Monitor, No. 202 for B/W Monitor)	6-114
6-2-27	Neck Grip (FRU No. 203)	6-117
6-2-28	Neck Space Plate (FRU No. 204)	6-120
6-2-29	Neck Space Plate 2 (FRU No. 205)	6-122
6-2-30	Rotation Spacer (FRU No. 206)	6-124
6-2-31	Side Cover Left (FRU No. 301)	6-127
6-2-32	Side Cover Right (FRU No. 302)	6-128
6-2-33	Rear Cover (FRU No. 303)	6-129
6-2-34	Rear Door Assy (FRU No. 304)	6-130
6-2-35	Front Base Cover (FRU No. 305)	6-131
6-2-36	Front Cover (FRU No. 306)	6-132
6-2-37	Keyboard Bottom Cover (FRU No. 307)	6-134
6-2-38	Top Cover (FRU No. 308)	6-135
6-2-39	Front Bumper Set (FRU No. 310)	6-136
6-2-40	Corner Guard (FRU No. 311)	6-137
6-2-41	Probe Holder (FRU No. 312)	6-138

SECTION	TITLE	PAGE
---------	-------	------

CHAPTER 6 – RENEWAL PARTS (continued)

6-2-42	Gel Holder (FRU No. 313), Gel Holder Bottom (FRU No. 314)	6-139
6-2-43	Handle (FRU No. 315)	6-140
6-2-44	Air Filter (FRU No. 316)	6-141
6-2-45	Cable Arm Assy (FRU No. 317)	6-142
6-2-46	Front Caster Assy (FRU No. 318)	6-143
6-2-47	Rear Caster Assy (FRU No. 319)	6-144
6-2-48	Caster Cover Assy (FRU No. 320)	6-145
6-2-49	Keyboard Panel Assy (FRU No. 400)	6-147
6-2-50	Keyboard Assy (FRU No. 401), Keyboard Cover (FRU No. 402), Key Sheet (FRU No. 403)	6-148
6-2-51	Keyboard Knob Set (FRU No. 404)	6-151
6-2-52	Trackball (FRU No. 405)	6-152
6-2-53	Gain Encoder (FRU No. 410)	6-153
6-2-54	Keyboard Panel Assy (FRU No. 450)	6-155
6-2-55	Keyboard Cover Assy (FRU No. 451), SW PWB (FRU No. 462), Rubber Key (FRU No. 452, 453, 454, and 455)	6-156
6-2-56	Keyboard Knob Set (FRU No. 464)	6-159
6-2-57	Trackball (FRU No. 457)	6-160
6-2-58	TGC Assy (FRU No. 458)	6-161
6-2-59	Freeze Key Assy (FRU No. 459)	6-162
6-2-60	Rotary Encoder (FRU No. 460)	6-163
6-2-61	Rear CONN Panel Assy (FRU No. 501)	6-166
6-2-62	CNTIF Assy (FRU No. 502)	6-168
6-2-63	AVIF Assy or BVIF Assy (FRU No. 503)	6-169
6-2-64	Circuit Protector (FRU No. 504: 15A, FRU No. 505: 7.5A)	6-170
6-2-65	ECG Board Assy (FRU No. 506)	6-171
6-2-66	ECG Panel Assy (FRU No. 507)	6-172
6-2-67	Nest Fan Assy (FRU No. 511)	6-174
6-2-68	Probe CONN Set Assy (FRU No. 512 for 3 slots model, FRU No. 513 for 2 slots model)	6-176
6-2-69	Connector Cover (FRU No. 514)	6-178
6-2-70	Shield Finger Long (FRU No. 515), Shield Finger Short (FRU No. 516)	6-179
6-2-71	Probe CONN 1 Assy (FRU No. 517) or DCON Assy (FRU No. 518)	6-180
6-2-72	PRAG Assy (FRU No. 519)	6-182
6-2-73	MODD (FRU No. 520), MODD Fan (FRU No. 521), MODD Holder Assy (FRU No. 522)	6-184
6-2-74	HDD Assy (FRU No. 523), HDD Holder Assy (FRU No. 524)	6-189
6-2-75	HDDB Assy (FRU No. 525)	6-195
6-2-76	HDD LED Assy (FRU No. 526)	6-196
6-2-77	Power Switch Assy (FRU No. 527)	6-197
6-2-78	P.C. Board(s) (FRU No. 601 through 612)	6-198
6-2-79	Time Keeper RAM (FRU No. 613)	6-200
6-2-80	Time Keeper Battery (FRU No. 613B)	6-202
6-2-81	Time Keeper Battery (for MVME167-002B) (FRU No. 613C)	6-204
6-2-82	OMEM Assy (FRU No. 614)	6-206

SECTION	TITLE	PAGE
---------	-------	------

CHAPTER 6 – RENEWAL PARTS (continued)

6-2-83	Nest Mother Assy (FRU No. 615)	6-208
6-2-84	Mother IC (FRU No. 616)	6-210
6-2-85	High Voltage Assy (FRU No. 701)	6-214
6-2-86	HV Fan (FRU No. 702)	6-216
6-2-87	Low Voltage Unit (FRU No. 703)	6-218
6-2-88	Power Control Unit (FRU No. 704)	6-220
6-2-89	SSR Unit (FRU No. 705)	6-222
6-2-90	Power Inlet Unit (FRU No. 706 for 115V, FRU No. 707 for 220V)	6-224
6-2-91	PW Air Filter (FRU No. 708)	6-226
6-2-92	Filter Cover Set (FRU No. 709)	6-227
6-2-93	HV Unit (FRU No. 750)	6-230
6-2-94	Cooling Fan (FRU No. 751)	6-232
6-2-95	LV2 Unit (FRU No. 752)	6-234
6-2-96	TRIAC Unit (FRU No. 753)	6-236
6-2-97	Power Inlet Unit2 (FRU No. 754 for 115V, FRU No. 755 for 220V)	6-238
6-2-98	LV3 Unit (FRU No. 770)	6-240
6-3	FUSE REPLACEMENT	6-243
6-3-1	Introduction	6-243
6-3-2	Replacement Procedures	6-244
6-4	SYSTEM SOFTWARE INSTALLATION	6-251
6-4-1	Introduction	6-251
6-4-2	Preparing before Installation	6-252
6-4-3	Initializing Hard Disk	6-253
6-4-4	Installing Software	6-254
6-4-5	Final Procedures	6-255
6-5	POWER SUPPLY REPLACEMENT	6-257
6-5-1	Introduction	6-257
6-5-2	Replacement Procedures	6-257
6-6	REPLACING 2.5-INCH HDD ASSY WITH 3.5-INCH HDD ASSY	6-263
6-6-1	Introduction	6-263
6-6-2	Time Required	6-263
6-6-3	Parts Required	6-263
6-6-4	Procedures	6-263
6-7	REPLACING LV2 UNIT WITH LV3 UNIT	6-276
6-7-1	Introduction	6-276
6-7-2	Time Required	6-276
6-7-3	Parts Required	6-276
6-7-4	Procedures	6-276

SECTION	TITLE	PAGE
---------	-------	------

CHAPTER 7 – PERIODIC MAINTENANCE

7-1	INTRODUCTION	7-3
	7-1-1 Periodic Maintenance	7-3
7-2	PERIODIC MAINTENANCE PROCEDURE	7-3
	7-2-1 Visual Inspection	7-3
	7-2-2 Cleaning	7-4
	7-2-3 Measurement	7-6
	7-2-4 User Data Backup	7-6
	7-2-5 Note	7-6
7-3	ELECTRICAL SAFETY TEST	7-7
	7-3-1 Outlet Test Wiring Arrangement	7-7
	7-3-2 Ground Continuity	7-8
	7-3-3 Chassis Leakage Current Test	7-9
	7-3-4 Probe Leakage Current Test	7-12
	7-3-5 ECG Leakage Current Test	7-16
	7-3-6 When There's Too Much Leakage Current	7-20

CHAPTER 8 – OPTIONS

8-1	INTRODUCTION	8-5
8-2	VIDEO CASSETTE RECORDER INSTALLATION	8-6
	8-2-1 Foreword	8-6
	8-2-2 Tools Required	8-6
	8-2-3 Time Required	8-6
	8-2-4 Parts Required	8-6
	8-2-5 Functional Check-out	8-7
	8-2-6 Installing VCR on Console	8-8
	8-2-7 Installing VCR on Color Monitor	8-13
	8-2-8 Connecting Cables	8-19
	8-2-9 Setting DIP Switches	8-20
	8-2-10 Operational Check-out	8-20
	8-2-11 Final Procedures	8-23
	8-2-12 Renewal Parts	8-24

SECTION	TITLE	PAGE
---------	-------	------

CHAPTER 8 – OPTIONS (continued)

8-3	COLOR VIDEO PRINTER INSTALLATION	8-25
8-3-1	Foreword	8-25
8-3-2	Tools Required	8-25
8-3-3	Time Required	8-25
8-3-4	Parts Required	8-25
8-3-5	Functional Check-out	8-26
8-3-6	Installing Color Video Printer on Console	8-26
8-3-7	Connecting Cables	8-31
8-3-8	Setting DIP Switches	8-33
8-3-9	Setting Parameters of UP-2950 Series Printers	8-33
8-3-10	Operational Check-out	8-36
8-3-11	Final Procedures	8-40
8-3-12	Renewal Parts	8-41
8-4	B/W PRINTER INSTALLATION	8-42
8-4-1	Foreword	8-42
8-4-2	Tools Required	8-42
8-4-3	Time Required	8-42
8-4-4	Parts Required	8-42
8-4-5	Functional Check-out	8-42
8-4-6	Setting DIP Switches	8-43
8-4-7	Installing B/W Video Printer on Console	8-43
8-4-8	Connecting Cables	8-47
8-4-9	Operational Check-out	8-48
8-4-10	Final Procedures	8-51
8-4-11	Renewal Parts	8-51
8-5	ECG OPTION INSTALLATION	8-52
8-5-1	Foreword	8-52
8-5-2	Tools Required	8-52
8-5-3	Time Required	8-52
8-5-4	Parts Required	8-52
8-5-5	Functional Check-out	8-52
8-5-6	Installing ECG Board Assy	8-53
8-5-7	Installing ECG Panel Assy	8-55
8-5-8	Operational Check-out	8-57
8-5-9	Attaching Caution Label	8-66
8-5-10	Final Procedures	8-67
8-5-11	Renewal Parts	8-69

SECTION	TITLE	PAGE
---------	-------	------

CHAPTER 8 – OPTIONS (continued)

8-6	EXPANDED CINE MEMORY INSTALLATION	8-70
	8-6-1 Foreword	8-70
	8-6-2 Tools Required	8-70
	8-6-3 Time Required	8-70
	8-6-4 Parts Required	8-70
	8-6-5 Functional Check-out	8-70
	8-6-6 Accessing Board Assy	8-71
	8-6-7 Installing OMEM Assy	8-72
	8-6-8 Operational Check-out	8-74
	8-6-9 Final Procedures	8-75
	8-6-10 Renewal Parts	8-77
8-7	FOOT SWITCH INSTALLATION	8-78
	8-7-1 Foreword	8-78
	8-7-2 Tools Required	8-78
	8-7-3 Time Required	8-78
	8-7-4 Parts Required	8-78
	8-7-5 Functional Check-out	8-78
	8-7-6 Connecting Foot Switch	8-79
	8-7-7 Operational Check-out	8-80
	8-7-8 Final Procedures	8-80
8-8	SWIVEL LOCK INSTALLATION	8-81
	8-8-1 Foreword	8-81
	8-8-2 Tools Required	8-81
	8-8-3 Time Required	8-81
	8-8-4 Parts Required	8-81
	8-8-5 Functional Check-out	8-81
	8-8-6 Installing Swivel Lock	8-82
	8-8-7 Operational Check-out	8-84
	8-8-8 Final Procedures	8-84

SECTION	TITLE	PAGE
---------	-------	------

CHAPTER 8 – OPTIONS (continued)

8-9	LEFT SIDE PROBE HOLDER INSTALLATION	8-85
	8-9-1 Foreword	8-85
	8-9-2 Tools Required	8-85
	8-9-3 Time Required	8-85
	8-9-4 Parts Required	8-85
	8-9-5 Installing Left Side Probe Holder	8-85
	8-9-6 Operational Check-out	8-86
	8-9-7 Final Procedures	8-86
8-10	MTZ PROBE HOLDER INSTALLATION	8-87
	8-10-1 Foreword	8-87
	8-10-2 Tools Required	8-87
	8-10-3 Time Required	8-87
	8-10-4 Parts Required	8-87
	8-10-5 Installing MTZ Probe Holder	8-88
	8-10-6 Final Procedures	8-88

1-1 SERVICE MANUAL CONTENTS

This manual provides service information on the LOGIQ™ 400 Ultrasound Scanning System. It contains the following chapters:

1. **Chapter 1, Introduction:** Contains a content summary and warnings;
2. **Chapter 2, Installation:** Contains physical and electrical requirements that must be considered prior to installation and a complete LOGIQ™ 400 installation procedure with installation checklist;
3. **Chapter 3, System Configuration:** Contains system configuration and specifications;
4. **Chapter 4, Functional Checks:** Contains functional checks that must be performed as part of the installation, or as required during servicing and periodic maintenance;
5. **Chapter 5, Diagrams:** Contains block diagrams and functional explanations of the LOGIQ™ 400 electronics;
6. **Chapter 6, Renewal Parts:** Contains a complete list of replacement parts for the LOGIQ™ 400 and disassembly procedures for all changeable FRU;
7. **Chapter 7, Periodic Maintenance:** Provides periodic maintenance procedures for the LOGIQ™ 400.
8. **Chapter 8, Options:** Provides installation procedures and changeable FRU for the optional devices.

1-2 SAFETY

1-2-1 Warnings



CAREFULLY READ ALL THE WARNINGS LISTED BELOW!

1. The operator manual should be fully read and understood before operating the LOGIQ™ 400 and kept nearby for quick reference.
2. Although the ultrasound energy transmitted from the LOGIQ™ 400 transducer is within AIUM/NEMA standards, unnecessary exposure should be avoided. Only trained personnel should operate the LOGIQ™ 400.
3. To prevent electrical shock, the LOGIQ™ 400 should be connected to a properly grounded power receptacle. Do not use a three prong to two prong adapter. This defeats safety grounding.
4. Do not use with Defibrillator when LOGIQ™ 400 is being operated .
5. Probes are fragile, please handle with care.
6. Concerning Outside Markings, refer to Illustration 1-1, 1-2, 1-3, 1-4, 1-5, 1-6, and 1-7.
7. For the cleaning, disinfection, and sterilization, refer to Probe section in LOGIQ™ 400 User Manual and Caution Sheet supplied with each probe.

NOTICE

This medical equipment is approved, in terms of the prevention of radio wave interference, to be used in hospitals, clinics and other institutions which are environmentally qualified. The use of this equipment in an inappropriate environment may cause some electronic interference to radios and televisions around the equipment. Proper handling of this equipment is required in order to avoid such trouble according to the operator and service manuals.

This equipment can be used in residential areas only under the supervision of physicians or qualified technicians.



Improper performance possibility. Do not use the following devices near this equipment. Cellular phone, radio transceiver, mobile radio transmitter, radio-controlled toy, etc. Use of these devices near this equipment could cause this equipment to perform outside the published specifications. Keep power to these devices turned off when near this equipment.

1-2-1 Warnings (continued)

CAUTION 注意 ACHTUNG ATTENTION
ATTENZIONE ATENÇÃO ATENCION

To avoid injury by tipping over, SET THE MONITOR TO THE LOWEST POSITION BEFORE MOVING.

危険を避けるため転倒に注意。移動の前にはモニターアームを最下位置まで下げてください。

Da ein Umkippen zu Verletzungen führen kann, DEN MONITOR DES GERÄTES AUF VORSTELLUNGSWECHSEL AUF DIE NIERIGSTE POSITION EINSTELLEN.

Pour éviter le basculement accidentel de la machine, BAISSER LE MONITEUR AVANT LE DÉPLACEMENT.

PREDISPORRE IL MONITOR NELLA POSIZIONE PIÙ BASSA PRIMA DI MUOVERE la macchina, per evitare rischi di ferite causate dal ribaltamento.

Para evitar danos por deslizamientos, POSICIONE O MONITOR NO SEU NÍVEL MAIS BAIXO.

Para evitar daños por deslizamientos, POSICIONE EL MONITOR A SU NIVEL MÁS BAJO ANTES DE MOVERLO.

CAUTION 注意 ACHTUNG ATTENTION
ATTENZIONE ATENÇÃO ATENCION

To avoid injury by tipping over, DO NOT PUSH THIS UNIT FROM THE SIDES.

危険を避けるため転倒に注意。側面から押さないこと。

Da ein Umkippen zu Verletzungen führen kann, DIE EINHEIT NICHT VON DER SEITE SCHIEBEN.

Pour éviter le basculement accidentel de la machine, NE PAS LA POUSSER PAR LE CÔTÉ.

NON SPRINGERE LA MACCHINA DI LATO Per evitare rischi di ferite causate dal ribaltamento.

Para evitar danos por deslizamientos, NÃO MOVA A UNIDADE PELAS LATERAIS.

Para evitar daños por deslizamientos, NO EMPUJE LA UNIDAD POR LOS LADOS.

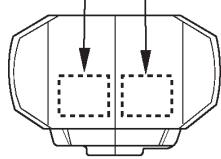

CAUTION 注意 ACHTUNG ATTENTION
ATTENZIONE ATENÇÃO ATENCION

To avoid injury by tipping over, SET THE MONITOR TO THE LOWEST POSITION BEFORE MOVING.

Во избежание травм вследствие переворачивания монитора ПЕРЕД ПЕРЕМЕЩЕНИЕМ МОНИТОРА УСТАНОВИТЕ ЕГО В САМОЕ НИЖНЕЕ ПОЛОЖЕНИЕ.

För att undvika skada genom tippning, STÄLL MONITORN I SITT LÅGSTA LÄGE FÖRE FÖRFLYTTNING.

Fare for overtipping, for at undgå uheld, SÆT MONITOREN I DEN LAVESTE POSITION FØR FLYTNING.

Πο να αποφεύγετε τον τραυματισμό από τυχόν πτώση, ΘΕΣΤΕ ΤΗΝ ΘΘΝΗ ΣΤΗ ΧΑΜΗΛΟΤΕΡΗ ΘΕΣΗ ΠΡΟΤΥΤΗ ΜΕΤΑΚΙΝΗΣΕΤΕ.

Devlrime nedeñlye yaranlanmanñ dñenmeñ iññ HAREKET ETTİRMEĐEN ÖNCE MONİTORÜ EN ALÇAK KONUMA GETİRİN

CAUTION 注意 ACHTUNG ATTENTION
ATTENZIONE ATENÇÃO ATENCION

To avoid injury by tipping over, DO NOT PUSH THIS UNIT FROM THE SIDES.

Во избежание травм вследствие переворачивания монитора НЕ ДОПУСКАЙТЕ БОКОВЫХ ТОЛЧКОВ МОНИТОРА.

För att undvika skada genom tippning, SKJUT INTE DENNA ENHET SIDLEDES.

Fare for overtipping, for at undgå uheld, SKUB IKKE PÅ DENNE ENHED FRA SIDEN.

Πο να αποφεύγετε τον τραυματισμό από τυχόν πτώση, ΜΗΝ ΘΘΒΕΤΕ ΤΗ ΜΟΝΑΔΑ ΑΥΤΗ ΑΠΟ ΤΟ ΠΛΑΙ.

Devlrime nedeñlye yaranlanmanñ dñenmeñ iññ BU ÜNİTEYİ YANLARDAN İTMEYİN.

Labels including English, Russian, Swedish, Danish, Greek, and Turkish [supplied with European Console]

WARNING 警告 WARNING AVERTISSEMENT AVVERTENZE ADVERTENCIA ADVERTENCIA

Hazardous movement can cause serious injury. Keep your head and body away from above video monitor support arm. Video monitor support arm is spring loaded. Releasing arm when monitor is not attached will cause sudden upward movement.

危険を避けるため落下しに注意。頭や手をモニターアームのそばに近づけないこと。ビデオモニターが解放されていない状態でモニターアームのロックを解除すると、モニターアームが飛び出します。

Gefährliche Bewegungen können zu schweren Verletzungen führen. Bringen Sie nicht Gesicht oder Hände in die Nähe des Videomonitorsupportarms. Der Videomonitorsupportarm ist federbelastet. Entriegelung des Arms ohne aufgesetzten Monitor läßt den Arm nach oben federn.

Tout mouvement dangereux peut provoquer des blessures sérieuses. Se tenir à bonne distance du bras de support à ressorts du moniteur vidéo. Quand le moniteur n'est pas monté, la libération du bras provoquera son soulèvement brutal.

Bruschi movimenti possono provocare ferite. Tenete la testa ed il corpo lontano dal supporto del monitor quando il monitor non è montato. Lo sganciamento accidentale del supporto può causare un improvviso movimento di quest'ultimo verso l'alto.

Movimentos perigosos podem causar sérios danos. Mantenha sua cabeça e corpo afastados da parte superior da alavanca de suporte do monitor de vídeo. Alavanca de suporte do monitor de vídeo é equipada de mola. Liberando a alavanca, quando o monitor não estiver fixado, causará repentino movimento dirigido para cima.

El movimiento peligroso puede ocasionar daños serios. Mantenga la cabeza y el cuerpo apartados de la parte superior del brazo de soporte del monitor de vídeo. El brazo de soporte del monitor de vídeo tiene carga de resorte. Si se suelta el brazo cuando no está montado el monitor, se ocasionará el movimiento súbito hacia arriba.

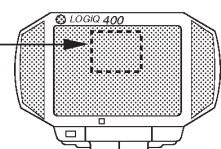

OUTSIDE MARKINGS OF LOGIQ™ 400 (For Color Monitor Models) ILLUSTRATION 1-1

Note

For further details regarding the cautions above, refer to 2-2-10 MOVING INTO POSITION in Chapter 2.

1-2-1 Warnings (continued)

CAUTION 注意 注意 注意 注意 注意 注意

To avoid injury by tipping over, SET THE MONITOR TO THE LOWEST POSITION BEFORE MOVING.

怪傷を避けるため転倒に注意。機器の移動時にはモニターアームを最下位置まで下げたから移動のこと。

Da ein Umkippen zu Verletzungen führen kann, DEN MONITOR DES GERÄTES VOR STELLUNGSWECHSEL AUF DIE NIEDRIGSTE POSITION EINSTELLEN.

Pour éviter tout risque de blessure dû au basculement accidentel de la machine, RÉGLER LE MONITEUR À SA POSITION LA PLUS BASSE AVANT SON DÉPLACEMENT.

PREDISPORRE IL MONITOR NELLA POSIZIONE PIÙ BASSA PRIMA DI MUOVERE la macchina, per evitare rischi di ferite causate dal ribaltamento.

Para evitar danos por deslizamento, POSICIONE O MONITOR NO SEU NÍVEL MAIS BAIXO ANTES DE MOVER O EQUIPAMENTO.

Para evitar daños por deslizamientos, POSICIONE EL MONITOR A SU NIVEL MÁS BAJO ANTES DE MOVERLO.



CAUTION 注意 注意 注意 注意 注意 注意

To avoid injury by tipping over, DO NOT PUSH THIS UNIT FROM THE SIDES.

怪傷を避けるため転倒に注意。機器の側面から押さないこと。

Da ein Umkippen zu Verletzungen führen kann, DIE EINHEIT NICHT VON DER SEITE SCHIEBEN.

Pour éviter tout risque de blessure dû au basculement accidentel de la machine, NE PAS LA POUSSER PAR LE CÔTÉ.

Per evitare rischi di ferite causate dal ribaltamento, NON SPINGERE LA MACCHINA DI LATO.

Para evitar danos por deslizamento, NÃO MOVA A UNIDADE PELA LATERAIS.

Para evitar daños por deslizamientos, NO EMPUJE LA UNIDAD POR LOS LADOS.

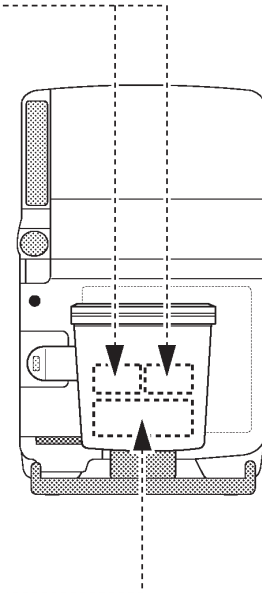
CAUTION 注意 注意 注意 注意 注意 注意

Possible injury. Placing objects on top of the monitor may cause the monitor to tilt with the falling objects resulting in injury to the operator. Do not place any objects on the monitor

怪傷の可能性あり。モニタ上に物を載せるとモニタが傾き、物が落下して怪傷をすることがあります。モニタの上に物を載せないこと。

Eventuelle Verletzungsgefahr. Auf den Monitor gelegte Gegenstände können ihn neigen und herunterfallende Gegenstände evtl. Verletzungen verursachen. Keinerlei Gegenstände auf den Monitor legen.

Risque de blessure possible : le poids d'objets posés sur le moniteur peut le faire s'incliner. Afin d'éviter tout risque de blessure occasionné par la chute de ces objets, ne rien poser sur le moniteur.

Rischio di lesione. Eventuali oggetti riposti sul monitor, ne possono provocare l'inclinamento. Per evitare il rischio di caduta di tali oggetti con conseguenti ferite, non riporre alcun oggetto sul monitor.

Existe a possibilidade de ocorrer acidentes. Caso algum objeto seja colocado sobre o monitor, este poderá inclinar-se e o objeto poderá cair, provocando algum acidente. Não coloque nenhum objeto sobre o monitor.

Existen posibilidades de lesiones. Al colocar objetos sobre el monitor, puede inclinarse el monitor, caerse los objetos y causar lesiones. No colocar objetos sobre el monitor.

WARNING 注意 注意 注意 注意 注意 注意

Hazardous movement can cause serious injury. Keep your head and body away from above video monitor support arm. Video monitor support arm is spring loaded. Releasing arm when monitor is not attached will cause sudden upward movement.

怪傷を避けるため飛び出しに注意。頭や手をモニターアームの上に乗ってはいけません。ビデオモニターが固定されていない状態でモニターアームのロックを解除すると、モニターアームが飛び出します。

Risikante Aktionen können zu schweren Verletzungen führen. Bringen Sie nicht Gesicht oder Hände in die Nähe des Videomonitortragesarms. Der Videomonitortragesarm ist federelastisch. Eine Entriegelung des Arms ohne aufgesetzten Monitor läßt den Arm nach oben federn.

Tout mouvement aléatoire peut provoquer des blessures sérieuses. Se tenir à bonne distance du bras de support du moniteur vidéo. Quand le moniteur n'est pas fixé, la libération du bras provoque son soulèvement brutal.

Qualsiasi movimento brusco può causare ferite gravi. Tenere la testa e il corpo a debita distanza dal braccio del monitor, in quanto è montato su molla. Lo sgancimento accidentale del supporto può causare un improvviso movimento di quest'ultimo verso l'alto.

Movimentos perigosos podem causar danos sérios. Mantenha sua cabeça e corpo afastados da parte superior do elevaçoes de suporte do monitor de vídeo. A liberação de suporte do monitor de vídeo é equipada de mola. Liberando a elevaçoes, quando o monitor não estiver fixado, causará movimento repentino dirigido para cima.

Un movimiento brusco puede ocasionar daños serios. Mantenga la cabeza y el cuerpo apartados de la parte superior del brazo de soporte del monitor de vídeo. El brazo de soporte del monitor de vídeo tiene carga de resorte. Si se suelta el brazo cuando no está montado el monitor, se ocasionará el movimiento súbito hacia arriba.

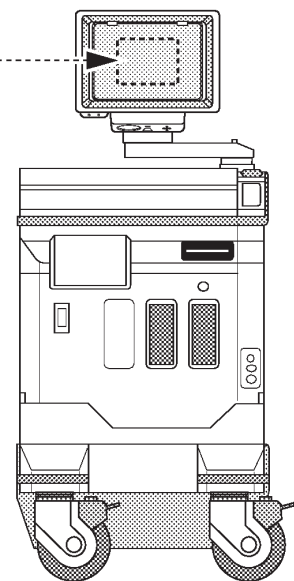
OUTSIDE MARKINGS OF LOGIQ™ 400 (For B/W Monitor Models with S/W V3.40 or earlier)
ILLUSTRATION 1-2

Note

For further details regarding the cautions above, refer to 2-2-10 MOVING INTO POSITION in Chapter 2.

Note

B/W system is applied the color monitor from software version 4.01y.

1-2-1 Warnings (continued)

CAUTION

Possible Injury. Placing objects on top of the monitor may cause the monitor to tilt with the falling objects resulting in injury to the operator. Do not place any objects on the monitor.

<p>CAUTION 注意 ACHTUNG ATTENTION ATTENZIONE ATENÇÃO ATENCIÓN</p>	
<p>Possible injury. Placing objects on top of the monitor may cause the monitor to tilt with the falling objects resulting in injury to the operator. Do not place any objects on the monitor.</p> <p>怪我の可能性あり。モニタ上に物を置けるとモニタが傾き、物が落下して怪我をすることがあります。モニタの上に物を載せないこと。</p> <p>Eventuelle Verletzungsgefahr. Auf den Monitor gelegte Gegenstände können ihn neigen und herunterfallende Gegenstände evtl. Verletzungen verursachen. Keinerlei Gegenstände auf den Monitor legen.</p> <p>Risque de blessure possible : le poids d'objets posés sur le moniteur peut le faire s'incliner. Afin d'éviter tout risque de blessure occasionné par la chute de ces objets, ne rien poser sur le moniteur.</p>	<p>Rischio di lesione. Eventuali oggetti riposti sul monitor, ne possono provocare l'inclinamento. Per evitare il rischio di caduta di tali oggetti con conseguenti ferite, non riporre alcun oggetto sul monitor.</p> <p>Existe a possibilidade de ocorrer acidentes. Caso algum objeto seja colocado sobre o monitor, este poderá inclinar-se e o objeto poderá cair, provocando algum acidente. Não coloque nenhum objeto sobre o monitor.</p> <p>Existen posibilidades de lesiones. Al colocar objetos sobre el monitor, puede inclinarse el monitor, caerse los objetos y causar lesiones. No colocar objetos sobre el monitor.</p>

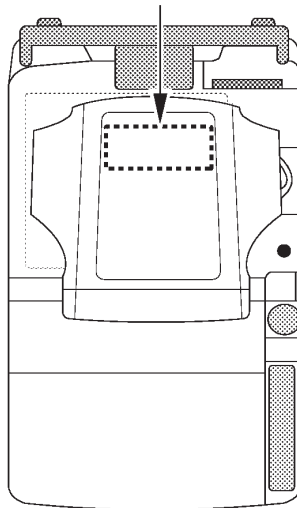

<p>CAUTION ВНИМАНИЕ! FÖRSIKTIG FÖRSIGTIG ΠΡΟΣΟΧΗ ΔΙΚΚΑΤ</p>	
<p>Possible injury. Placing objects on top of the monitor may cause the monitor to tilt with the falling objects resulting in injury to the operator. Do not place any objects on the monitor.</p> <p>Возможные травмы. Размещение каких-либо предметов на верхней поверхности монитора может привести к наклону монитора, в результате чего падающие с него предметы могут нанести травму оператору. Не допускайте размещения на мониторе посторонних предметов.</p> <p>Skaderisk. Om föremål placeras ovanpå monitorn kan den tippa varvid föremålen kan falla på operatören och orsaka skada. Placera inga föremål på monitorn.</p>	<p>Fare for uheld. Genstande, der placeres ovenpå monitoren, kan få bordet til at vælte, og den faldende genstand kan forårsage skade på operatøren. Undlad at placere genstande oven på monitoren.</p> <p>Πιθανός τραυματισμός. Η τοποθέτηση αντικειμένων επάνω στην οθόνη μπορεί να προκαλέσει την κλίση της, με αποτέλεσμα τα αντικείμενα να πέσουν και να τραυματίσουν το χειριστή. Μην τοποθετείτε αντικείμενα στην οθόνη.</p> <p>Muhtemel yaralanma. Monitörün üzerine eşya konulması, monitörün yana yatmasına ve düştün eşyaların operatörün yaralanmasına yolaçabilir. Monitörün üzerine herhangi bir eşya koymayın.</p>

Labels including English, Russian, Swedish, Danish, Greek, and Turkish [supplied with European Console]

OUTSIDE MARKINGS OF LOGIQ™ 400 (For Color Monitor Models)
ILLUSTRATION 1-3

1-2-1 Warnings (continued)

CAUTION 注意 注意 注意 注意 注意 注意 注意 注意

Do not use the following devices near this equipment. Cellular phone, radio transceiver, mobile radio transmitter, radio controlled toy, etc. Use of these devices near this equipment could cause this equipment to perform outside the published specifications. Keep power to these devices turned off when near this equipment.

本機付近では以下の機器を使用しないでください。本機が仕壊から外れた動作をすることがあります。携帯電話、トランシーバー、携帯無線機、ラジオコンのおもちゃなど。本機の近くではこれらの機器の電源スイッチを切ってください。

In der Nähe dieses Systems folgende Geräte nicht benutzen: Funktelefone, Radioempfänger, mobile Radiosender, ferngesteuertes Spielzeug, usw. Der Gebrauch dieser Geräte könnte während des Betriebes Fehlfunktionen verursachen. Schalten Sie die Stromversorgung dieser Geräte in der Nähe der Ausrüstung ab.

Près de ne pas utiliser les appareils suivants à proximité de cet équipement: téléphones portables, émetteurs-récepteurs, appareils radio-commandés, etc. Ce type d'appareil peut faire dévier les performances du système en dehors des spécifications annoncées. Mettre ces appareils hors tension lorsqu'ils se trouvent à proximité de cet équipement.

Non utilizzare mai i seguenti dispositivi nelle vicinanze di questa apparecchiatura: telefoni cellulari, ricevatrasmettitori radio, trasmettitori radiomobili, giocattoli telecomandati, ecc. L'utilizzo di tali dispositivi potrebbe provocare il disfunzionamento di questa apparecchiatura. Tenere spenti tali dispositivi nelle vicinanze di questa apparecchiatura.

Favor não utilizar os seguintes aparelhos perto deste equipamento. Telefone móvel, rádio trans-receptor, rádio transmissor móvel, brinquedos de controle remoto, etc. A utilização desses aparelhos perto deste equipamento pode fazer com que não funcione segundo as especificações publicadas. Favor manter esses aparelhos desligados quando estiverem perto deste equipamento.

No utilice los siguientes aparatos cerca de este equipo. Teléfono móvil, transmisor-receptor, transmisor de radio móvil, juguete radio controlado, etc. La utilización de estos aparatos cerca de este equipo puede hacer que el equipo no funcione según las especificaciones publicadas. Mantenga estos aparatos apagados cuando esté cerca de este equipo.

WARNING 警告 警告 警告 警告 警告 警告 警告 警告

Possible shock hazard. Do not remove Covers or Panels. Refer servicing to qualified personnel.

感電の危険あり。カバー(または背板)を取り除かないこと。修理点検はサービスセンターに依頼すること。

Gefahr eines elektrischen Schlags! Abdeckungen oder Verkleidungen nicht entfernen. Wartungsarbeiten nur durch qualifiziertes Fachpersonal durchführen lassen.

Risque de décharge électrique. Les capots et panneaux ne doivent être retirés que par un personnel qualifié.

Rischio di scosse elettriche. I pannelli di chiusura devono essere rimossi solo da personale qualificato.

Possível choque. Não remova tampas ou painéis. Solicite assistência técnica por pessoal qualificado.

Peligro de descargas eléctricas. No saque las cubiertas ni los paneles. El servicio debe realizarlo el personal cualificado.

For continued protection against fire or shock hazard. Replace only with same type and rating of Fuse.

火災の危険あり。表示されたヒューズと交換のこと。

Zum dauerhaften Geräteschutz und zur Vermeidung elektrischer Schläge nur Sicherungen des gleichen Typs und Nennwertes verwenden.

Pour éviter tout risque de décharge électrique ou d'incendie, les fusibles de remplacement doivent respecter le type et le calibre spécifiés pour la tension réseau choisie.

Sostituire i fusibili utilizzando soltanto fusibili dello stesso tipo, dimensione e amperaggio.

Para proteção contínua contra fogo ou choque. Substitua somente com fusível do mesmo tipo e capacidade.

Como protección continua contra descargas eléctricas e incendios, reemplaza el fusible sólo por otro que sea del mismo tipo y del mismo amperaje.

Grounding reliability can only be achieved when this equipment is connected to a receptacle marked "Hospital Only" or "Hospital Grade".

この機器は「医用コンセント(Ⓜマーク)」に接続したときのみ保護接地の信頼性が保証されません。

United States law restricts this device to sale or use by or on the order of a physician.

▲ DANGER 危険 危険 危険 危険 危険 危険 危険 危険

Possible explosion hazard if used in the presence of flammable anesthetics.

爆発の危険あり。引火性麻酔剤のある場所では使用しないこと。

Risque d'explosion. Ne pas utiliser en présence d'anesthésiques inflammables.

Explosionsgefahr! Nicht in Gegenwart brennbarer Narkosegase verwenden.

Rischio di esplosione se il sistema è usato in presenza di gas anestetici infiammabili.

Riesgo de explosión. No emplear en presencia de anestésicos inflamables.

Possível explosão se usado na presença de anestésicos inflamáveis.

MADE FOR GE MEDICAL SYSTEMS
MILWAUKEE, WISCONSIN BY
GE YOKOGAWA MEDICAL SYSTEMS LTD.
TOKYO, JAPAN

CLASS I

MODEL LOGIQ 400
SERIAL
MANUFACTURED
VOLTS 120Vac 1PHASE
POWER 1000VA
FREQUENCY 60Hz



ETL LISTED
CONFORMS TO
UL STD. 2601-1
4507

CERTIFIED TO
CAN/CSA C22.2 NO. 601.1
ETL TESTING LABORATORIES INC.
CORTLAND, NEW YORK 13842

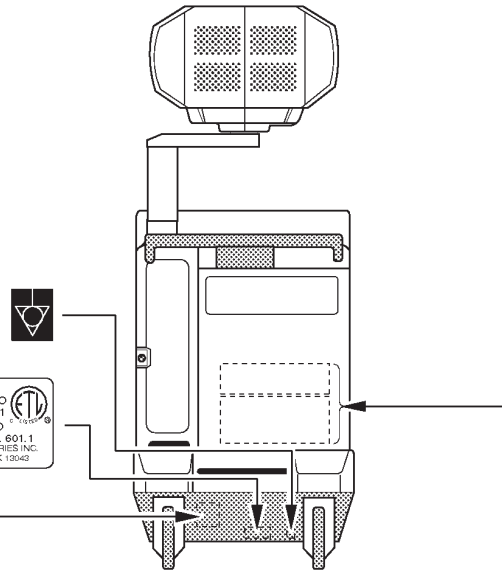

OUTSIDE MARKINGS OF LOGIQ™ 400 (For USA)
ILLUSTRATION 1-4

Note

For the symbols shown in the illustration above, refer to latter pages in this chapter. The CAUTION label for the radio influence is attached on the console from April, 1996.

1-2-1 Warnings (continued)

<p>CAUTION 注意 ACHTUNG ATTENTION ATTENZIONE ATENÇÃO ATENCIÓN</p>	
<p>Do not use the following devices near this equipment. Cellular phone, radio transceiver, mobile radio transmitter, radio controlled toy, etc. Use of these devices near this equipment could cause this equipment to perform outside the published specifications. Keep power to these devices turned off when near this equipment.</p> <p>本機の近くでは以下の機器を使用しないでください。本機が仕様から外れた動作をすることがあります。携帯電話、トランシーバー、携帯無線機、ラジオコンのおもちゃなど。本機の近くではこれらの機器の電源スイッチを切ってください。</p> <p>In der Nähe dieser Ausrüstung folgende Geräte nicht benutzen: Funktelefone, Radioempfänger, mobile Radiosender, ferngesteuertes Spielzeug, usw. Der Gebrauch dieser Geräte könnte während des Betriebes Fehlfunktionen verursachen. Schalten Sie die Stromversorgung dieser Geräte in der Nähe der Ausrüstung ab.</p> <p>Prière de ne pas utiliser les appareils suivant à côté de cet équipement. Les Téléphones portables, les transmetteurs radioles, les radios mobiles, les commandes à distance, etc. L'utilisation de ces appareils à proximité de cet équipement peut amener l'équipement à fonctionner en dehors des spécifications publiées.</p> <p>Prière d'éteindre ces appareils lorsqu'ils sont à proximité de cet équipement.</p>	<p>Non utilizzare mai i dispositivi menzionati di seguito vicino a questo apparecchio. Telefono cellulare, ricetrasmittitore di radio, trasmettitore di radio mobile, giocattoli con controllo di radio, ecc. La utilizzazione dei dispositivi potrebbe causare il funzionamento anormale di questo apparecchio. Tenere spenti tali dispositivi quando vicini a questo apparecchio.</p> <p>Favor não utilizar os seguintes aparelhos perto deste equipamento. Telefone móvel, rádio trans-receptor, rádio transmissor móvel, brinquedos à controle remoto, etc. A utilização desses aparelhos perto deste equipamento pode fazê-lo com que não funcione segundo as especificações publicadas. Favor manter esses aparelhos desligados quando estiverem perto deste equipamento.</p> <p>No utilice los siguientes aparatos cerca de este equipo. Teléfono móvil, transmisor-receptor, transmisor de radio móvil, juguete radio controlado, etc. La utilización de estos aparatos cerca de este equipo puede hacer con que el equipo no funcione según las especificaciones publicadas. Mantenga estos aparatos apagados cuando cerca de este equipo.</p>

<p>WARNING 警告 WARNUNG AVERTISSEMENT AVVERTENZE ADVERTENCIA ADVERTENCIA</p>				
<p>Possible shock hazard. Do not remove Covers or Panels. Refer servicing to qualified personnel.</p> <p>感電の危険あり。カバー（または背板）を取り除かないこと。修理点検はサービスセンターに依頼すること。</p> <p>Schlaggefahr! Abdeckung en oder Verkleidungen nicht entfernen. Wartungsarbeiten nur durch qualifiziertes Fachpersonal durchführen lassen.</p> <p>Risque de chocs électriques. La capot ne doit être ouvert que par un personnel qualifié.</p>	<p>Rischio di scosse elettriche, i pannelli di chiusura dello strumento devono essere tolti solo dal personale qualificato.</p> <p>Possível choque. Não remova tampas ou painéis. Solicite à assistência técnica por pessoal qualificado.</p> <p>Peligro de descargas eléctricas. No saque las cubiertas ni los paneles. El servicio debe realizarlo el personal cualificado.</p>	<p>For continued protection against fire or shock hazard. Replace only with same type and rating of Fuse.</p> <p>火災の危険あり。表示されたヒューズと交換のこと。</p> <p>Zum dauerhaften Geräteschutz und zur Vermeidung elektrischer Schläge nur Sicherungen des gleichen Typs und Nennwertes verwenden.</p> <p>Les fusibles de remplacement doivent respecter le type et le calibre spécifiés pour la tension réseau choisie.</p>	<p>Sostituire i fusibili utilizzando soltanto fusibili dello stesso tipo, dimensione e valori di corrente.</p> <p>Para proteção continua contra fogo ou choque. Substitua somente com fusível do mesmo tipo e capacidade.</p> <p>Como protección continua contra descargas eléctricas e Incendios, reemplace el fusible sólo por otro que sea del mismo tipo y del mismo amperaje.</p>	<p>Grounding reliability can only be achieved when this equipment is connected to a receptacle marked "Hospital Only" or "Hospital Grade".</p> <p>この機種は「医用コンセント（Hマーク）」に接続したときのみ保護接地の信頼性が保証されます。</p>

<p>DANGER 危険 VORSICHT DANGER PERICOLO PERIGO PELIGRO</p>			
<p>Possible explosion hazard if used in the presence of flammable anesthetics.</p> <p>爆発の危険あり。引火性麻酔剤のある場所では使用しないこと。</p>	<p>Explosionsgefahr! Nicht in Gegenwart brennbarer Narkosegase verwenden.</p> <p>Risque d'explosion. Ne pas employer en présence d'anesthésiques inflammables.</p>	<p>Possibilità di esplosione se il sistema è usato in presenza di gas anestetici infiammabili.</p> <p>Possível explosão se usado na presença de anestésicos inflamáveis.</p>	<p>Riesgo de explosión. No emplear en presencia de anestésicos inflamables.</p>

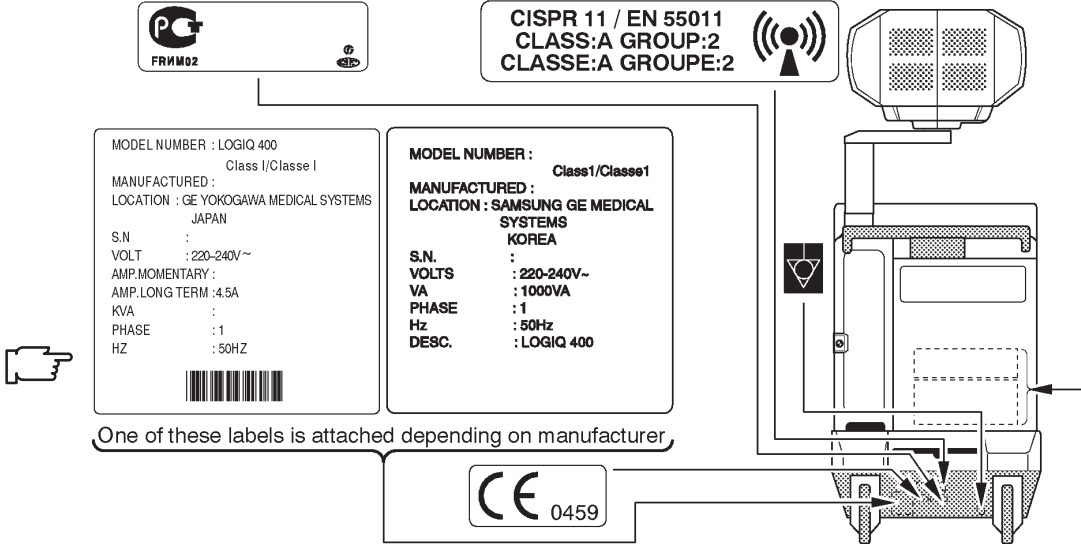

One of these labels is attached depending on manufacturer

OUTSIDE MARKINGS OF LOGIQ™ 400 (For Europe) ILLUSTRATION 1-5

Note

For the symbols shown in the illustration above, refer to latter pages in this chapter. The CAUTION label for the radio influence is attached on the console from April, 1996. The GOST label is attached on the console from June, 1998.

1-2-1 Warnings (continued)

<p>CAUTION 注意</p>	<p>WARNING 警告</p>	<p>AVVERTIMENTO 警告</p>	<p>AVVERTENZE 警告</p>	<p>AVVERTÊNCIA 警告</p>	<p>AVVERTENCIA 警告</p>
<p>Do not use the following devices near this equipment. Cellular phone, radio transceiver, mobile radio transmitter, radio controlled toy, etc. Use of these devices near this equipment could cause this equipment to perform outside the published specifications. Keep power to these devices turned off when near this equipment.</p> <p>本機の近くでは以下の機器を使用しないでください。本機が仕掛けられた動作をすることがあります。携帯電話、トランシーバー、携帯無線機、ラジオコンのおもちゃなど。本機の近くではこれらの機器の電源スイッチを切ってください。</p> <p>In der Nähe dieses Systems folgende Geräte nicht benutzen: Funktelefone, Radioempfänger, mobile Radiosender, ferngesteuertes Spielzeug, usw. Der Gebrauch dieser Geräte könnte während des Betriebes Fehlfunktionen verursachen. Schalten Sie die Stromversorgung dieser Geräte in der Nähe der Ausrüstung ab.</p> <p>Prêre de ne pas utiliser les appareils suivants à proximité de cet équipement: téléphones portables, émetteurs-récepteurs, appareils radio-commandés, etc. Ce type d'appareil peut faire dévler les performances du système en dehors des spécifications annoncées. Mettre ces appareils hors tension lorsqu'ils se trouvent à proximité de cet équipement.</p>	<p>Possibile shock hazard. Do not remove Covers or Panels. Refer servicing to qualified personnel.</p> <p>感電の危険あり。カバー(または背板)を取り除かないこと。修理点検はサービスマンに依頼すること。</p> <p>Gefahr eines elektrischen Schlags! Abdeckungen oder Verkleidungen nicht entfernen. Wartungsarbeiten nur durch qualifiziertes Fachpersonal durchführen lassen.</p> <p>Risque de décharge électrique. Les capots et panneaux ne doivent être retirés que par un personnel qualifié.</p>	<p>Rischio di scosse elettriche. I pannelli di chiusura devono essere rimossi solo da personale qualificato.</p> <p>Possível choque. Não remova tampas ou painéis. Solicite assistência técnica por pessoal qualificado.</p> <p>Peligro de descargas eléctricas. No saque las cubiertas ni los paneles. El servicio debe realizarlo el personal cualificado.</p>	<p>For continued protection against fire or shock hazard. Replace only with same type and rating of Fuse.</p> <p>火災の危険あり。表示されたヒューズと交換のこと。</p> <p>Zum dauerhaften Geräteschutz und zur Vermeidung elektrischer Schläge nur Sicherungen des gleichen Typs und Nennwertes verwenden.</p> <p>Pour éviter tout risque de décharge électrique ou d'incendie, les fusibles de remplacement doivent respecter le type et le calibre spécifiés pour la tension réseau choisie.</p>	<p>Sostituire i fusibili utilizzando soltanto fusibili dello stesso tipo, dimensione e amperaggio.</p> <p>Para proteção contínua contra fogo ou choque. Substitua somente com fusível do mesmo tipo e capacidade.</p> <p>Como protección continua contra descargas eléctricas e incendios, reemplace el fusible sólo por otro que sea del mismo tipo y del mismo amperaje.</p>	<p>Grounding reliability can only be achieved when this equipment is connected to a receptacle marked "Hospital Only" or "Hospital Grade".</p> <p>この機器は「医用コンセント (Hマーク)」に接続したときのみ保護接地の信頼性が保証されます。</p> <p>Warning</p> <p>United States law restricts this device to sale or use by or on the order of a physician.</p>

<p>WARNING 警告</p>	<p>AVVERTIMENTO 警告</p>	<p>AVVERTENZE 警告</p>	<p>AVVERTENCIA 警告</p>	<p>AVVERTENCIA 警告</p>
<p>Possibile shock hazard. Do not remove Covers or Panels. Refer servicing to qualified personnel.</p> <p>感電の危険あり。カバー(または背板)を取り除かないこと。修理点検はサービスマンに依頼すること。</p> <p>Gefahr eines elektrischen Schlags! Abdeckungen oder Verkleidungen nicht entfernen. Wartungsarbeiten nur durch qualifiziertes Fachpersonal durchführen lassen.</p> <p>Risque de décharge électrique. Les capots et panneaux ne doivent être retirés que par un personnel qualifié.</p>	<p>Rischio di scosse elettriche. I pannelli di chiusura devono essere rimossi solo da personale qualificato.</p> <p>Possível choque. Não remova tampas ou painéis. Solicite assistência técnica por pessoal qualificado.</p> <p>Peligro de descargas eléctricas. No saque las cubiertas ni los paneles. El servicio debe realizarlo el personal cualificado.</p>	<p>For continued protection against fire or shock hazard. Replace only with same type and rating of Fuse.</p> <p>火災の危険あり。表示されたヒューズと交換のこと。</p> <p>Zum dauerhaften Geräteschutz und zur Vermeidung elektrischer Schläge nur Sicherungen des gleichen Typs und Nennwertes verwenden.</p> <p>Pour éviter tout risque de décharge électrique ou d'incendie, les fusibles de remplacement doivent respecter le type et le calibre spécifiés pour la tension réseau choisie.</p>	<p>Sostituire i fusibili utilizzando soltanto fusibili dello stesso tipo, dimensione e amperaggio.</p> <p>Para proteção contínua contra fogo ou choque. Substitua somente com fusível do mesmo tipo e capacidade.</p> <p>Como protección continua contra descargas eléctricas e incendios, reemplace el fusible sólo por otro que sea del mismo tipo y del mismo amperaje.</p>	<p>Grounding reliability can only be achieved when this equipment is connected to a receptacle marked "Hospital Only" or "Hospital Grade".</p> <p>この機器は「医用コンセント (Hマーク)」に接続したときのみ保護接地の信頼性が保証されます。</p> <p>Warning</p> <p>United States law restricts this device to sale or use by or on the order of a physician.</p>

<p>DANGER 危険</p>	<p>GEFAHR 危険</p>	<p>DANGER 危険</p>	<p>PERICOLO 危険</p>	<p>PERIGO 危険</p>	<p>PELIGRO 危険</p>
<p>Possible explosion hazard if used in the presence of flammable anesthetics.</p> <p>爆発の危険あり。引火性麻酔剤のある場所では使用しないこと。</p>	<p>Explosionsgefahr! Nicht in Gegenwart brennbarer Narkosegase verwenden.</p> <p>Risque d'explosion. Ne pas utiliser en présence d'anesthésiques inflammables.</p>	<p>Rischio di esplosione se il sistema è usato in presenza di gas anestetici infiammabili.</p> <p>Possível explosão se usado na presença de anestésicos inflamáveis.</p>	<p>Riesgo de explosión. No emplear en presencia de anestésicos inflamables.</p>		

EMC
IEC 601-1-2 :1993

この装置は、病院、診療所、研究機関等で使用される医療電子機器です。それ以外の環境で使用するとラジオ、テレビジョン受信機等に受信障害を与えることがあります。VCIM-グループ 2・クラス A

名称 : 汎用超音波画像診断装置
 形名 : LOGIQ 400
 電源 : 単相 100V~, 50/60Hz
 消費電力 : 1000VA
 保護形式 : クラス I
 製造番号 :
 承認番号 :

製造元 : ジーイー横河メディカルシステム株式会社
 東京都日野市旭が丘4-7-127
 GE Yokogawa Medical Systems



OLD

名称 : 汎用超音波画像診断装置 LOGIQ 400
 形名 :
 定格電源 : 単相 100V~, 50/60Hz
 消費電力 : 1000VA
 保護形式 : クラス I
 製造番号 :
 承認番号 :
 製造年月 :

製造元 : ジーイー横河メディカルシステム株式会社
 東京都日野市旭が丘4-7-127
 GE Yokogawa Medical Systems



NEW

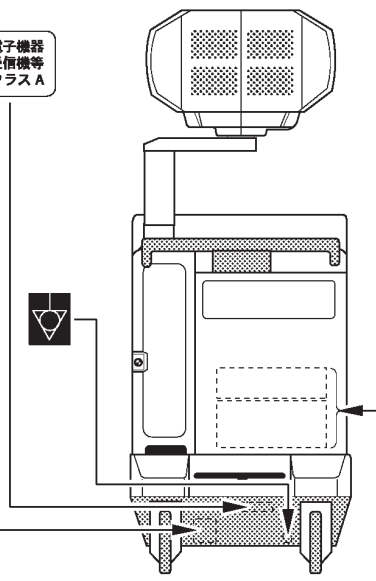

OUTSIDE MARKINGS OF LOGIQ™ 400 (For Japan)
ILLUSTRATION 1-7

Note

For the symbols shown in the illustration above, refer to latter pages in this chapter.
 The CAUTION label for the radio influence is attached on the console from April, 1996.
 The Japanese EMC label is attached on the console with the software version 4.10 or later instead of the VCIM label.

1-2-1 Warnings (continued)

⚠ CAUTION	注意	ACHTUNG	ATTENTION	ATTENZIONE	ATENÇÃO	ATENCIÓN
<p>Do not use the following devices near this equipment. Cellular phone, radio transceiver, mobile radio transmitter, radio controlled toy, etc. Use of these devices near this equipment could cause this equipment to perform outside the published specifications. Keep power to these devices turned off when near this equipment.</p> <p>本機の近くでは以下の機器を使用しないでください。本機が仕様から外れた動作をすることがあります。携帯電話、トランシーバー、携帯無線機、ラジコンのおもちゃなど。本機の近くではこれらの機器の電源スイッチを切ってください。</p> <p>In der Nähe dieser Ausrüstung folgende Geräte nicht benutzen: Funktelefone, Radioempfänger, mobile Radiosender, ferngesteuertes Spielzeug, usw. Der Gebrauch dieser Geräte könnte während des Betriebes Fehlfunktionen verursachen. Schalten Sie die Stromversorgung dieser Geräte in der Nähe der Ausrüstung ab.</p> <p>Prière de ne pas utiliser les appareils suivant à côté de cet équipement. Les Téléphones portables, les transmetteurs radios, les radios mobiles, les commandes à distance, etc. L'utilisation de ces appareils à proximité de cet équipement peut amener l'équipement à fonctionner en dehors des spécifications publiées.</p> <p>Prière d'éteindre ces appareils lorsqu'ils sont à proximité de cet équipement.</p>						
<p>Non utilizzare mai i dispositivi menzionati di seguito vicino a questo apparecchio. Telefono cellulare, ricetrasmittitore di radio, trasmettore di radio mobile, giocattoli con controllo di radio, ecc. La utilizzazione dei dispositivi potrebbe causare il funzionamento anormale di questo apparecchio. Tenere spenti tali dispositivi quando vicini a questo apparecchio.</p> <p>Favor não utilizar os seguintes aparelhos perto deste equipamento. Telefone móvel, rádio trans-receptor, rádio transmissor móvel, brinquedos à controle remoto, etc. A utilização desses aparelhos perto deste equipamento pode fazê-lo com que não funcione segundo as especificações publicadas. Favor manter esses aparelhos desligados quando estiverem perto deste equipamento.</p> <p>No utilice los siguientes aparatos cerca de este equipo. Teléfono móvil, transmisor-receptor, transmisor de radio móvil, juguete radio controlado, etc. La utilización de estos aparatos cerca de este equipo puede hacer con que el equipo no funcione según las especificaciones publicadas.</p> <p>Mantenga estos aparatos apagados cuando cerca de este equipo.</p>						

⚠ WARNING	警告	WARNING	AVERTISSEMENT	AVVERTENZE	ADVERTENCIA	ADVERTENCIA
<p>Possible shock hazard. Do not remove Covers or Panels. Refer servicing to qualified personnel.</p> <p>電撃の危険あり。カバー（または背板）を取り除かないこと。修理点検はサービスセンターに依頼すること。</p> <p>Schlaggefahr! Abdeckung en oder Verkleidungen nicht entfernen. Wartungsarbeiten nur durch qualifiziertes Fachpersonal durchführen lassen.</p> <p>Risque de chocs électriques. La capot ne doit être ouvert que par un personnel qualifié.</p>	<p>Rischio di scosse elettriche, i pannelli di chiusura dello strumento devono essere tolti solo dal personale qualificato.</p> <p>Possível choque. Não remova tampas ou painéis. Solicite à assistência técnica por pessoal qualificado.</p> <p>Peligro de descargas eléctricas. No saque las cubiertas ni los paneles. El servicio debe realizarlo el personal cualificado.</p>	<p>For continued protection against fire or shock hazard. Replace only with same type and rating of Fuse.</p> <p>火災の危険あり。表示されたヒューズと交換のこと。</p> <p>Zum dauerhaften Geräteschutz und zur Vermeidung elektrischer Schläge nur Sicherungen des gleichen Typs und Nennwertes verwenden.</p> <p>Les fusibles de remplacement doivent respecter le type et le calibre spécifiés pour la tension réseau choisie.</p>	<p>Sostituire i fusibili utilizzando soltanto fusibili dello stesso tipo, dimensione e valori di corrente.</p> <p>Para proteção continua contra fogo ou choque. Substitua somente com fusível do mesmo tipo e capacidade.</p> <p>Como protección continua contra descargas eléctricas e incendios, reemplace el fusible sólo por otro que sea del mismo tipo y del mismo amperaje.</p>	<p>Grounding reliability can only be achieved when this equipment is connected to a receptacle marked "Hospital Only" or "Hospital Grade".</p> <p>この機器は「医用コンセント（Hマーク）」に接続したときにのみ保護接地の信頼性が保証されます。</p>		
						<p>⚠ CAUTION</p> <p>United States law restricts this device to sale or use by or on the order of a physician.</p>

⚠ DANGER	危険	VORSICHT	DANGER	PERICOLO	PERIGO	PELIGRO
<p>Possible explosion hazard if used in the presence of flammable anesthetics.</p> <p>爆発の危険あり。引火性麻醉剤のある場所では使用しないこと。</p>	<p>Explosionsgefahr! Nicht in Gegenwart brennbarer Narkosegase verwenden.</p> <p>Risque d'explosion. Ne pas employer en présence d'anesthésiques inflammables.</p>		<p>Possibilità di esplosione se il sistema é usato in presenza di gas anestetici infiammabili.</p> <p>Possível explosão se usado na presença de anestésicos inflamáveis.</p>		<p>Riesgo de explosión. No emplear en presencia de anestésicos inflamables.</p>	

품목허가번호 : 제 12호
명 칭 : 초음파 진단기
형 명 : LOGIQ 400
정격전압 : 220V 사용주파수 : 60Hz
소비전력 : 1000VA
보호형식 : CLASS 1
제조번호 :
제조사상호 : 삼성 GE 의료기기 주식회사
제조사주소 : 경기도 성남시 중원구
상대원동 65-1

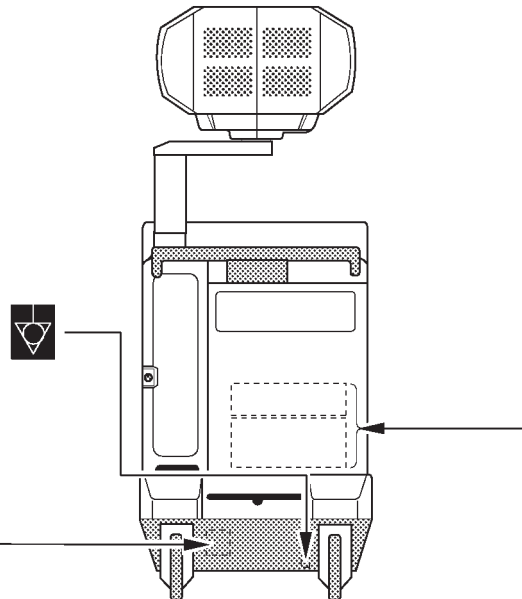

OUTSIDE MARKINGS OF LOGIQ™ 400 (For Korea)

ILLUSTRATION 1-8

Note

ILLUSTRATION 1-8 shows the labels attached on the console for Korea.

1-2-1 Warnings (Continued)

CAUTION

Do not use a Defibrillator simultaneously with the ECG, as its excessive voltage will damage the signal input block of the ECG unit.

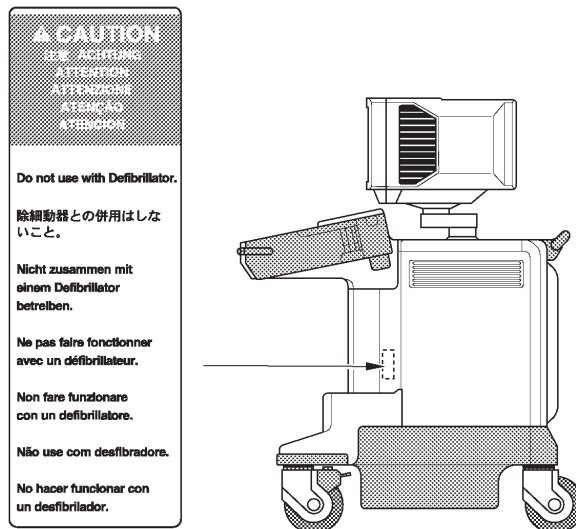

OUTSIDE MARKINGS OF LOGIQ™ 400 (For Units with ECG)
ILLUSTRATION 1-9

Note

This label is attached only on the LOGIQ™ 400 console with the optional ECG unit.

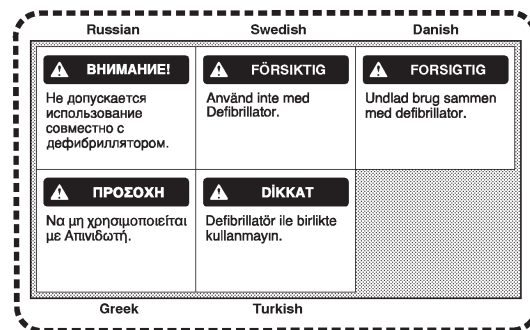

Labels including English, Russian, Swedish, Danish, Greek, and Turkish
[supplied with European Console]

EUROPEAN LANGUAGE LABEL ON ECG LABEL
ILLUSTRATION 1-10

Note

The labels shown in ILLUSTRATION 1-10 are supplied with the consoles for Europe. They shall be attached on the console over the existing labels as necessary. Refer to the installation instructions supplied with the labels.

1-2-1 Warnings (Continued)

WARNING!

HAZARDOUS VOLTAGE. 140VDC CAN CAUSE A SEVERE INJURY OR DEATH, OR THE POWER SUPPLY TO BE DAMAGED. TURN OFF THE POWER AND CHECK THE RESIDUAL VOLTAGE OF CAPACITORS BEFORE ACCESSING THE POWER SUPPLY UNIT. CAREFULLY WORK WHILE ACCESSING THE POWER SUPPLY UNIT.

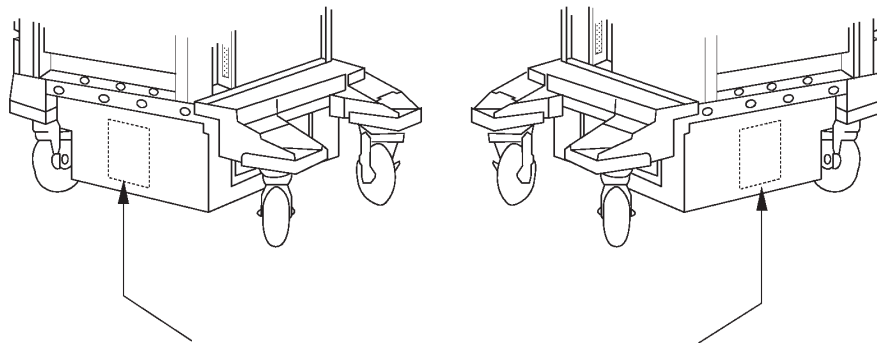

⚠ WARNING

⚡

**Hazardous Voltage
140Vdc
Can Cause
severe injury, death
or damage
power supply.**

Turn off power and check residual voltage of capacitor before access in the power box.





OUTSIDE MARKINGS OF LOGIQ™ 400 (ON POWER SUPPLY BOX)
ILLUSTRATION 1-11

Note







Same labels are attached on both left and right outside of the power supply unit.

1-2-1 Warnings (Continued)

The following table describes the purpose and location of safety labels and other important information provided on the equipment.

Label/Symbol	Purpose/Meaning	Location
Identification and Rating Plate	<ul style="list-style-type: none"> • Manufacturer's name and address • Date of manufacture • Model and serial numbers • Electrical ratings 	Rear of console near power inlet
Type/Class Label	Used to indicate the degree of safety or protection.	
	Equipment Type BF (man in the box symbol) IEC 878-02-03 indicates B Type equipment having a floating applied part.	Probe connectors and PCG connector
	Equipment Type CF (heart in the box symbol) IEC 878-02-05 indicates equipment having a floating applied part having a degree of protection suitable for direct cardiac contact.	ECG connector and surgical probes
Device Listing/ Certification Labels	Laboratory logo or labels denoting conformance with industry safety standards such as UL or IEC.	Rear of console
"DANGER – Risk of explosion used in..."	The system is not designed for use with flammable anesthetic gases.	Rear of console
	<ul style="list-style-type: none"> • "CAUTION" The equilateral triangle is usually used in combination with other symbols to advise or warn the user. 	Various
	<ul style="list-style-type: none"> • "ATTENTION – Consult accompanying documents" is intended to alert the user to refer to the operator manual or other instructions when complete information cannot be provided on the label. 	Various
	<ul style="list-style-type: none"> • "WARNING – Dangerous voltage" (the lightning flash with arrowhead) is used to indicate electric shock hazards. 	Left and right side of power supply unit

1-2-1 Warnings (Continued)

Label/Symbol	Purpose/Meaning	Location
	<ul style="list-style-type: none"> • "Mains OFF" Indicates the power off position of the mains power switch. 	Rear of system Adjacent to mains switch
	<ul style="list-style-type: none"> • "OFF/Standby" Indicates the power off/standby position of the power switch. <p>CAUTION This Power Switch DOES NOT ISOLATE Mains Supply</p>	Adjacent to On-Off/Standby Switch
	<ul style="list-style-type: none"> • "Mains ON" Indicates the power on position of the mains power switch. 	Rear of system Adjacent to mains switch
	<ul style="list-style-type: none"> • "ON" Indicates the power on position of the power switch. <p>CAUTION This Power Switch DOES NOT ISOLATE Mains Supply</p>	Adjacent to On-Off/Standby Switch
	<ul style="list-style-type: none"> • "Protective Earth" Indicates the protective earth (grounding) terminal. 	Not used
	<ul style="list-style-type: none"> • "Equipotentiality" Indicates the terminal to be used for connecting equipotential conductors when interconnecting (grounding) with other equipment. 	Rear of console
	<ul style="list-style-type: none"> • "Non-ionizing Radiation" indicates that the system applies RF energy. 	Rear of console near power inlet

1-2-2 Specifications

- Type of protection against electric shock: Class I EQUIPMENT (*1)
- Degree of protection against electric shock: Type BF EQUIPMENT (*2) (Except ECG)
Type CF EQUIPMENT (*3) (ECG Only)

Ordinary Equipment
Continuous Operation

***1. Class I EQUIPMENT**

EQUIPMENT in which protection against electric shock does not rely on BASIC INSULATION only, but which includes an additional safety precaution in that means are provided for the connection of the EQUIPMENT to the protective earth conductor in the fixed wiring of the installation in such a way that ACCESSIBLE METAL PARTS cannot become LIVE in the event of a failure of the BASIC INSULATION.

***2. Type BF EQUIPMENT**

TYPE B EQUIPMENT with an F-TYPE APPLIED PART

TYPE B EQUIPMENT: EQUIPMENT providing a particular degree of protection against electric shock, particularly regarding:

- allowable LEAKAGE CURRENT;

	Normal mode	Single failure mode
Patient leakage current	Less than 100µA	Less than 500µA

***3. Type CF EQUIPMENT**

EQUIPMENT providing a particular degree of protection higher than that for TYPE OF BF EQUIPMENT against electric shock particularly regarding allowable LEAKAGE CURRENT, and having an F-TYPE APPLIED PART.

- allowable LEAKAGE CURRENT;

	Normal mode	Single failure mode
Patient leakage current	Less than 10µA	Less than 50µA

1-3 EMC (Electromagnetic Compatibility)

1-3-1 EMC Performance

All types of electronic equipment may characteristically cause electromagnetic interference with other equipment, either through air or connecting cables. The term EMC (Electromagnetic Compatibility) indicates capability of the equipment, which curbs electromagnetic influence from other equipment and at the same time does not affect other equipment with similar electromagnetic radiation from itself.

This product is designed to fully comply with the EN60601-1-2 (IEC601-1-2), in Medical electrical equipment EMC regulations.

Proper installation following this service manual is required in order to achieve the full EMC performance of the product.

The product must be installed as stipulated in 1-3-2, Notice upon Installation of Product.

In case of issues related to EMC, please follow procedures stated in 1-3-4, Countermeasures against EMC-related Issues.

1-3-2 Notice upon Installation of Product

- 1) Use either power supply cords provided by GEMS or ones designated by GEMS. Products equipped with power source plug should be plugged into the fixed power socket which has the protective grounding conductor.

Connect a three-pole plug to a three-pole socket without using a three-pole-to-two-pole converter.

- 2) Locate the equipment as far as possible from other electronic equipment.
- 3) Be sure to use either any cables provided by GEMS or ones designated by GEYMS. Wire these cables following these installation procedures.

(Example) Wire power cables separately from signal cables.

- 4) Lay out the main equipment and other peripherals following the installation procedures described in Chapter2, INSTALLATION.

1-3-3 General Notice

1) Designation of Peripheral Equipment Connectable to This Product

The equipment which conforms to EN60601-1-2 (IEC601-1-2), can be hooked up to the product without compromising its EMC performance.

Avoid using non-standardized equipment. Failure to comply with this instruction may result in poor EMC performance of the product.

2) Notice against User Modification

Never modify this product. Unilateral user modification may cause degradation in EMC performance. Modification of the product includes:

- a) Changes in cables (length, material, wiring etc.)
- b) Changes in system installation/layout
- c) Changes in system configuration/components
- d) Changes in means of fixing system/parts (cover open/close, cover screwing)

3) Operate the system with all covers closed. If you open any cover for some reason, be sure to shut it before starting/resuming operation.

Operating the system with any cover open may affect EMC performance.

1-3-4 Countermeasures against EMC-related Issues

Generally it is very difficult to grapple with issues related to EMC. It may take much time and cost.

General countermeasures

Electromagnetic interference with other equipment

- 1) Electromagnetic interference may be alleviated by positioning other equipment far from the system.
- 2) Electromagnetic interference may be mitigated by changing the relative location (installation angle) between the system and other equipment.
- 3) Electromagnetic interference may be eased by changing wiring locations of power/signal cables of other equipment.
- 4) Electromagnetic influence may be reduced by altering the path of power supply for other equipment.

1-3-5 Notice on Service

- 1) Ensure all screws are tight after servicing. Loose screws may cause degradation in EMC performance.
- 2) In case the high frequency gasket of this system is broken, replace it with a new one immediately.

1-4 ADDRESS

This system is not repairable by the customer. If this equipment does not work as indicated in the Operator Manual, please contact your service support center. If the service engineer needs additional information to repair this equipment, please contact the following address (The necessary information will be provided to the Service Engineer as needed):

GE Medical Systems

Ultrasound Business Group
4855 W. Electric Ave., Milwaukee, WI 53219
USA
TEL: (1) 800-437-1171
FAX: (1) 414-647-4090

CANADA

TEL: (1) 800-668-0732

LATIN & SOUTH AMERICA

TEL: (1) 305-735-2304

GE Ultrasound Europe

GE Ultraschall Deutschland GmbH & Co. KG
Beethovenstr. 239
42655 Solingen, GERMANY
TEL: OLC-Europe Toll Free Numbers
or
English/German Hotline (49) (212) 2802 207
English/German/French Hotline (49) (212) 2802 208
FAX: (49) (212) 2802 28

GE YOKOGAWA MEDICAL SYSTEMS

On-Line Center (OLC), Asia
Ultrasound Group
67-4 Takakura-cho, Hachioji-shi, Tokyo, 192-0033
JAPAN
TEL: (81) 426-48-2940
FAX: (81) 426-48-2905

2-1 PREINSTALLATION

2-1-1 Introduction

This section describes various general electrical, operational, and environmental considerations that must be considered before installing the LOGIQ™ 400 Ultrasound unit.

2-1-2 Power Line Requirements

The following power line parameters should be monitored for one week before installation. We recommend that you use an analyzer Dranetz Model 606-3 or Dranetz Model 626:

PARAMETER	:	LIMITS
Voltage Range	: Japan.	: 100 VAC ±10% (90–110 VAC)
	: Europe	: 220–240 VAC ±10% (198–264 VAC)
	USA	: 120 VAC ±10% (108–132 VAC)
Power	: Japan	: MAX. 1000 VA
	: Europe	: MAX. 1000 VA
	: USA	: MAX. 1000VA
Line Frequency	: All applications	: 50/60Hz (±2Hz)
Power Transients	:	Less than 25 % of nominal peak voltage for less than 1 millisecond for any type of transient, including line frequency, synchronous, asynchronous, or aperiodic transients.
Decaying Oscillation	:	Less than 15 % of peak voltage for less than 1 millisecond.

2-1-3 Physical Specifications

The LOGIQ™ 400 (excluding accessories) weighs 145 kg (320 lbs). See Chapter 3, ILLUSTRATION 3-1 for dimensions.

Operating Conditions

The LOGIQ™ 400 is designed to operate within a temperature range of 10 degrees C to 40 degrees C (50 degrees F to 104 degrees F), and a relative humidity range of 30 % to 85 % (Non-condensing).

Patient Comfort

Concerning permissible operating temperature and humidity tolerances, we recommend that ambient room temperature should be maintained between 20 to 26 degrees C (68 to 79 degrees F), Humidity should be maintained between 50 % and 70 % for patient comfort during ultrasound scanning.

Electromagnetic Interference (EMI)

Ultrasound machines are susceptible to interference from the radio frequencies, magnetic fields, and transients in the air or power leads. Possible EMI sources should be identified. Electrical and electronic equipment may produce EMI unintentionally as the result of a malfunction. These sources include medical lasers, cauterizing guns, computers, monitors, fans, gel warmers, microwave ovens, and cellular phones. The presence of broadcast station or van may also cause interference.

Carefully read the following precautions before installing the unit.

1. Connect the power plug for any other equipment into the fixed outlet with ground wire.
2. Securely connect any equipment with permanent ground connection to the earth ground furnished in the building.
3. Install the unit as far from any electrical or electronic equipment as possible.

If any EMI troubles are known or suspected to be present, try to deal with the equipment suspected to have influence on the Ultrasound machine as follows:

1. Move the ultrasound machine as far from the equipment as possible.
2. Change the arrangement of the equipment in the room.
3. Plug the equipment into other outlet.
4. Move the power cable or signal cable connected with the equipment.

Securely re-tighten drive any screws for the Ultrasound machine after re-assembling for service operation.

2-1-4 Recommended Ultrasound Room Layout

Table 2-1 provides the requirements for an ultrasound room:

TABLE 2-1
ULTRASOUND ROOM REQUIREMENTS



POWER SOURCE	220-240VAC, 50Hz, SINGLE PHASE For Europe Version 115VAC, 60Hz, SINGLE PHASE For USA Version
CURRENT RATING	15A (115V, 100V) ; 7.5A (220-240V) CIRCUIT BREAKER
RADIATION SHIELDING	NONE REQUIRED for ULTRASOUND ENERGY
TEMPERATURE	20-26 DEG. C (68-79 DEG F) for PATIENT COMFORT
HUMIDITY	50% to 70% for PATIENT COMFORT
HEAT DISSIPATION	2000 BTU/Hr for LOGIQ™ 400 ;
FLOOR LOADING	Approximately 680 – 800 kg/m ² without Accessories
FLOOR CONDITION	Gradient : WITHIN 5 degrees
LOGIQ™ 400 Weight	145 kg (320lbs) without Accessories

2-1-4 Recommended Ultrasound Room Layout (Continued)

Optional Desirable Ultrasound Room Facilities

These facilities are:

1. Lab sink with hot and cold water;
2. Emergency oxygen supply;
3. Dimmer control for overhead lights;
4. Film viewer;
5. Film and linen storage;
6. Medical equipment storage;
7. Hospital grade equipment electrical outlet;
8. Analog telephone line for connection to InSite;
9. Document storage area for operating and service manuals;
10. Nearby waiting room, dressing room, lavatory
11. Trash bin.

Recommended and Alternate Ultrasound Console Floor Plans

ILLUSTRATION 2-1 provides a recommended standard floor plan and a minimal floor plan for ultrasound equipment

2-1-4 Recommended Ultrasound Room Layout (Continued)

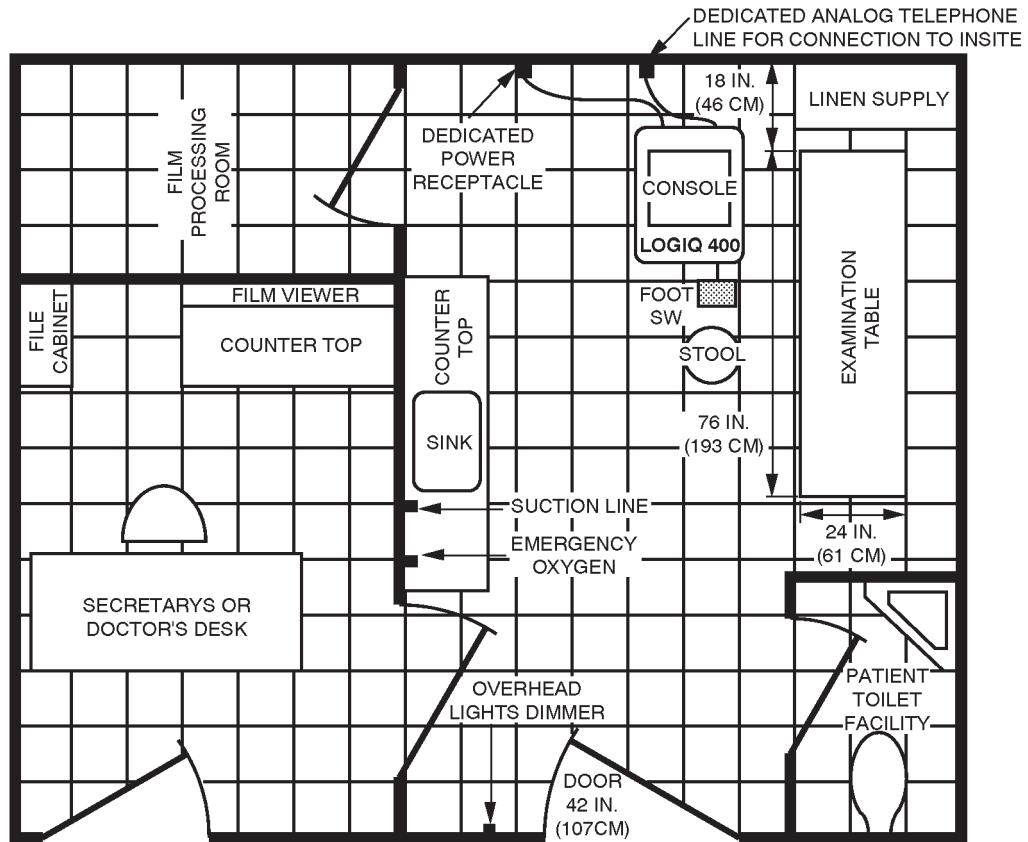

A 14 by 17 foot Recommended Floor Plan

Scale: Each square equals one square foot

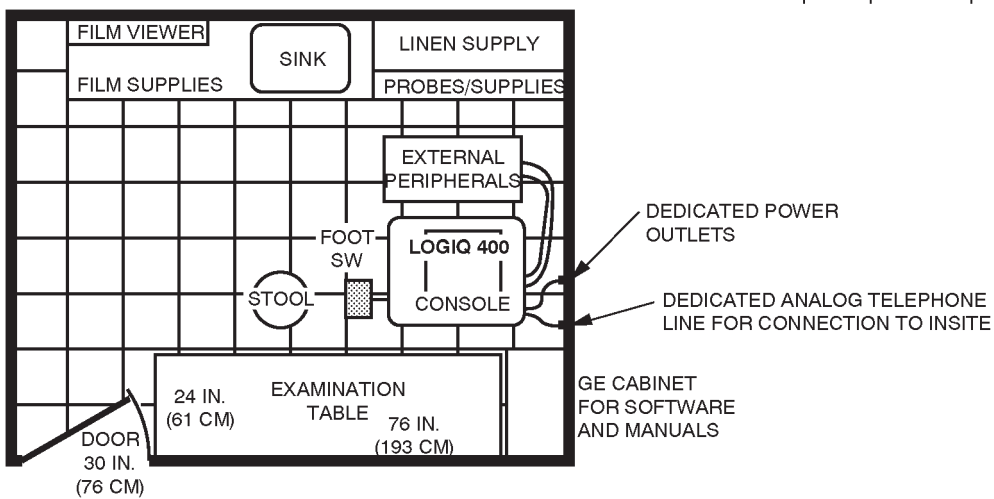

An 8 by 10 foot Minimal Floor Plan

RECOMMENDED ULTRASOUND FLOOR PLAN

ILLUSTRATION 2-1

2-2 INSTALLATION

2-2-1 Introduction

This section contains many of the procedures required to install the LOGIQ™ 400 console.

2-2-2 Average Installation Time

The LOGIQ™ 400 has been designed to be installed and checked out by an experienced service technician in approximately four hours. LOGIQ™ 400 consoles with optional equipment may take slightly longer.

2-2-3 Installation Warnings

1. Since the LOGIQ™ 400 weighs approximately 320 lbs (145 kg) without options, preferably two people should unpack it. Two people are also preferable for installing any additional bulky items.
2. There are no operator serviceable components. To prevent shock, do not remove any covers or panels. Should problems or malfunctions occur, unplug the power cord. Only qualified service personnel should carry out servicing and troubleshooting.

Note

For information regarding packing labels, refer to ILLUSTRATION 2-3, LABELS ON PACKAGE.

2-2-4 Checking the Components

When a new system arrives, check that any components are not damaged and are not in short supply. If shipping damage or shortage occurs, contact the address shown in Chapter 1.

2-2-5 Unpacking LOGIQ™ 400

Do not lift the unit by the Keyboard. Equipment damage may result.



The unit weighs approximately 145kg (320 lbs). Be prepared for a sudden shift of weight as the unit is removed from its base (pallet).

Refer to ILLUSTRATION 2-2 while performing the following procedure.

1. Cut the two PLASTIC BANDS.
2. Lift the TOP COVER up and off.
3. Lift the MONITOR CAP up and off.
4. Remove the three PLASTIC JOINTs from the OUTER SLEEVE.
5. Remove the OUTER SLEEVE.
6. Remove the INNER SLEEVE.
7. Remove the PLASTIC BAG.
8. Lift the Monitor up by pressing the <UP/DOWN Release> button located on the Monitor Arm.
9. Remove the MONITOR SUPPORTER.
10. Remove the adhesive tapes attached at the four corners of the TOP COVER.
11. Put the TOP COVER on floor and prepare the slope to put the console down as shown in ILLUSTRATION 2-2.
12. Unlock the brakes by stepping down on the brake pads in front, then carefully put the LOGIQ™ 400 console off the PALETTE.
13. Remove the Caution Label attached in front of the CRT (or CRT Filter) and clean the CRT (or CRT Filter).

Note

Check the shipping container for special instructions. Verify that the container is intact. In some cases a secondary container may be used. If so, ask the carrier for unpacking instructions.

2-2-5 Unpacking LOGIQ™ 400 (Continued)

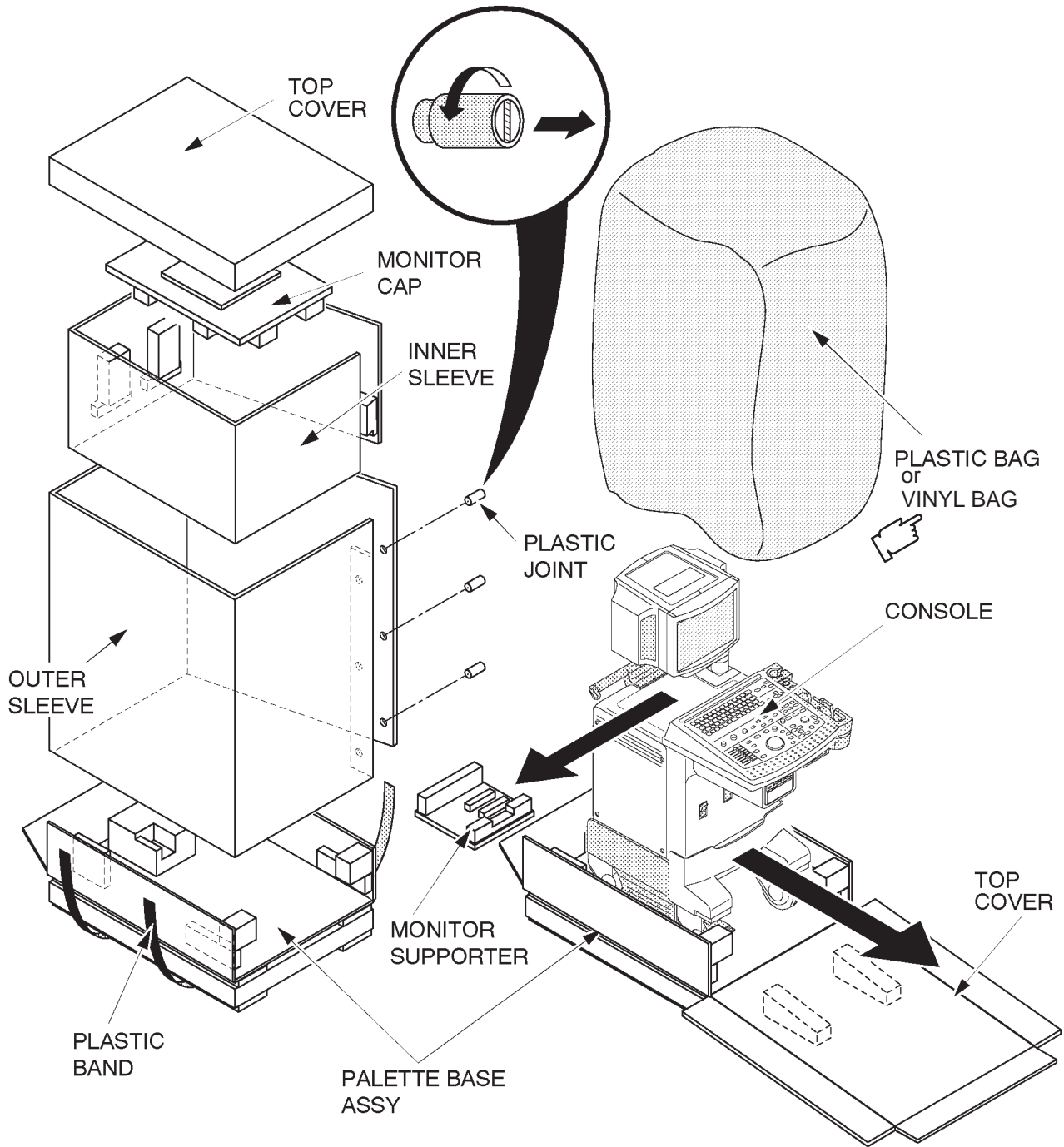

UNPACKING LOGIQ™ 400
ILLUSTRATION 2-2

2-2-5 Unpacking LOGIQ™ 400 (Continued)

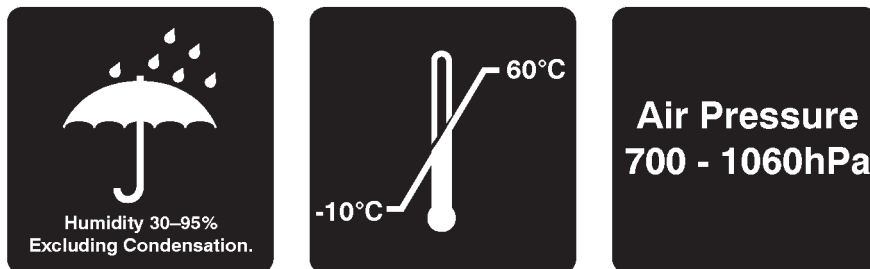

LABELS ON PACKAGE
ILLUSTRATION 2-3

2-2-6 Probe Cable Arm Installation

Probe Cable Arm is supplied with the LOGIQ™ 400 console (except to Japanese console). This provides the procedures for installing the probe cable arm onto console.

1. Set the arm spacer to the axis of the probe cable arm. Refer to ILLUSTRATION 2-4.
2. Insert the probe cable arm into the hole onto console as shown in ILLUSTRATION 2-4.

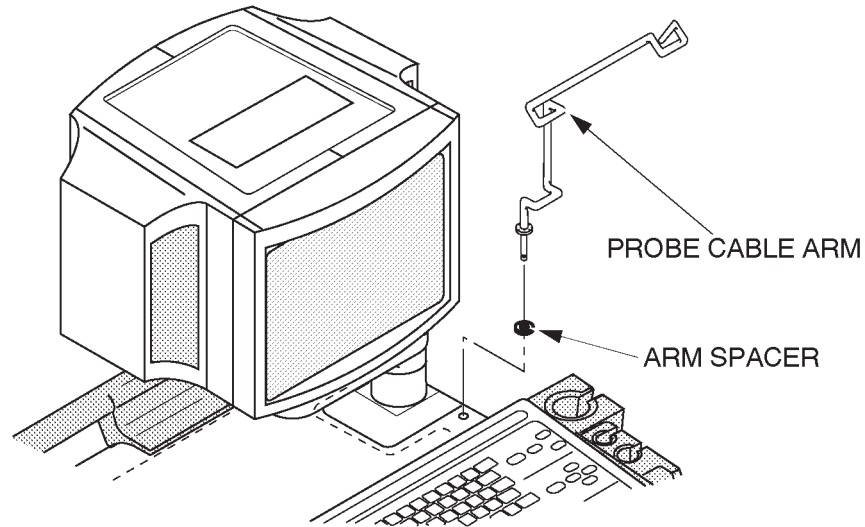

PROBE CABLE ARM INSTALLATION
ILLUSTRATION 2-4

2-2-7 MTZ Probe Holder Installation

One MTZ probe holder is supplied with the LOGIQ™ 400 console. Assemble the MTZ probe holder at the bottom of standard probe holder by screwing two screws (① and ②: supplied with the starter kit) as shown in ILLUSTRATION 2-5.

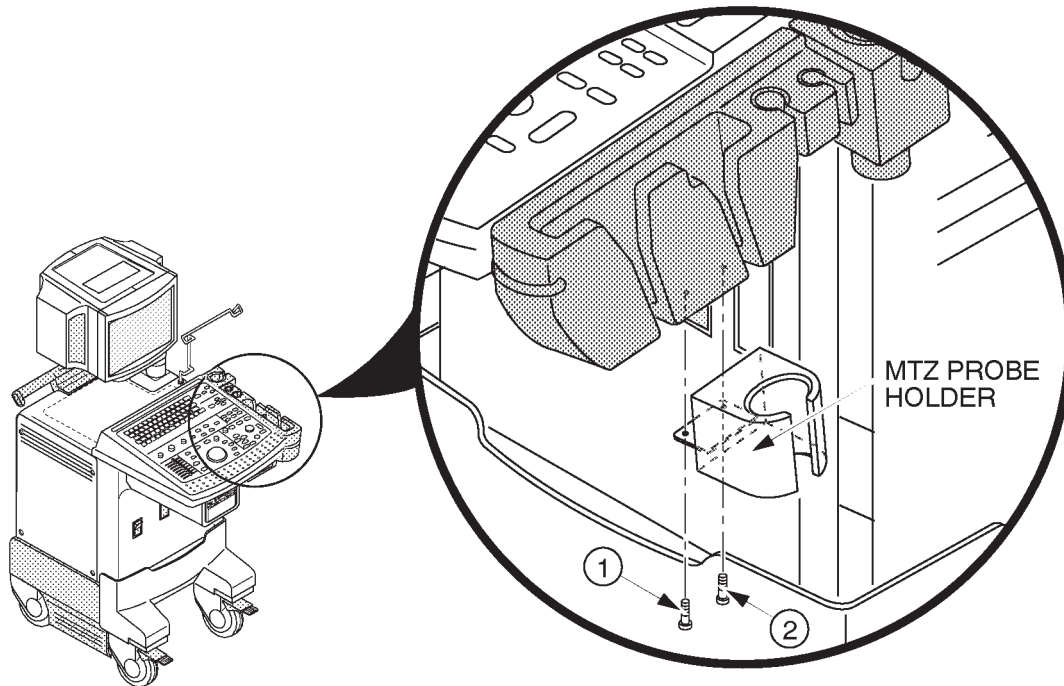

MTZ PROBE HOLDER INSTALLATION
ILLUSTRATION 2-5

2-2-8 Transducer Connection

Connect a transducer to the upper transducer receptacle as follows:

1. Ensure that the transducer twist lock lever points towards the 3 o'clock position.
2. Insert the transducer connector on the receptacle guide pin until it touches the receptacle mating surface.
3. Twist the transducer twist lock lever to the 7 o'clock position to lock it in place. Twist the lever to the 3 o'clock position to disconnect the transducer.

Note

It is not necessary to turn the system power OFF to connect or disconnect a transducer.

2-2-9 Powering-Up Procedure

1. Make sure that the circuit breaker located at the rear side of the PS Unit is set to OFF position (lower side). Refer to ILLUSTRATION 2-6.
2. Make sure that the main power switch located at the front side of console is set to OFF position. Refer to ILLUSTRATION 2-6.

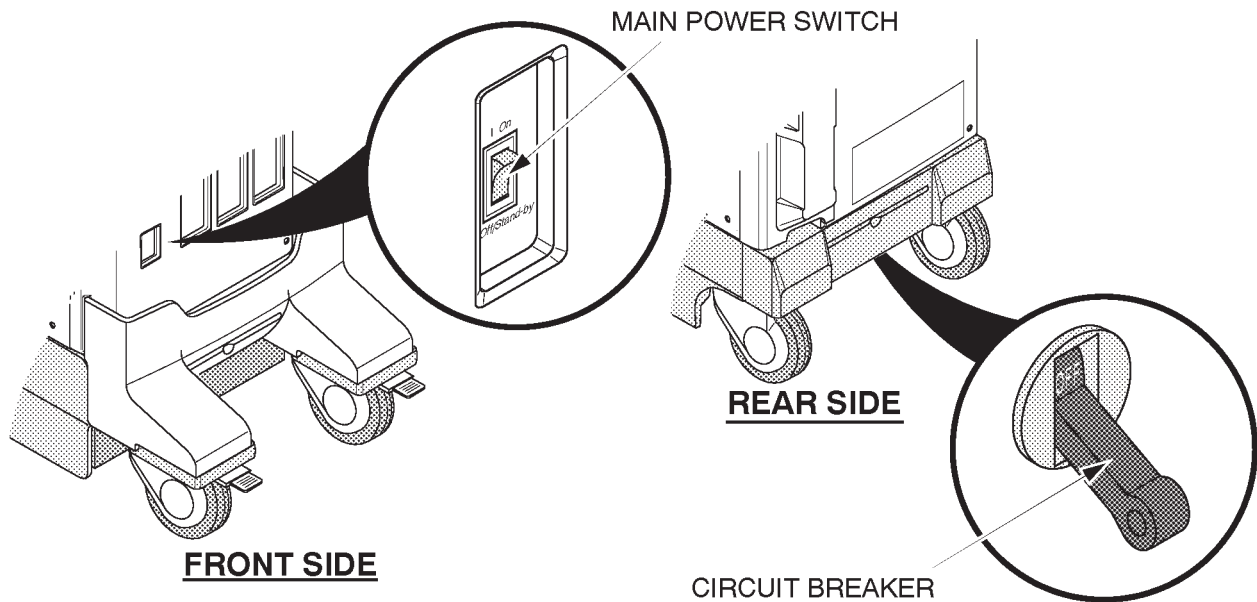

CIRCUIT BREAKER AND MAIN POWER SWITCH
ILLUSTRATION 2-6

3. Plug the main power cable to a hospital grade power receptacle with the proper rated voltage checked during preinstallation.

Note

Never use a three-to-two prong adapter; this defeats the safety ground.

4. Set the circuit breaker to ON position (upper side).
5. Turn the main power switch ON. LOGIQ™ 400 will start the power-up sequence.

Note

Follow the procedures below when unplugging the system.

1. Turn the main power switch OFF.
2. Wait a while until the power off process is completed.
3. Set the circuit breaker to OFF position (lower side).
4. Unplug the main power cable.

2-2-10 Moving into Position



Do not lift the unit by the Keyboard.

Do not tilt the unit more than 5 degrees to avoid tipping it over.

To avoid injury by tipping over. Set the monitor to the lowest position before moving.

In general, a single adult can move the LOGIQ™ 400 along an even surface with no steep grades. At least two people should move the machine when large humps, grooves, or grades will be encountered. (It is better to pull from the rear rather than push from the front of the unit). Before moving, store all loose parts in the unit. Wrap transducers in soft cloth or foam to prevent damage.

Although LOGIQ™ 400 is a compact and mobile machine, two people should move it over rough surfaces or up and down grades.

2-2-11 Adjusting System Clock

Set the system clock for the LOGIQ™ 400 to the local time. For procedure of adjusting the system clock, refer to 4-3-3 Utility Menu, (A) TIME ADJUSTMENT, in Chapter 4, FUNCTIONAL CHECKS.

2-2-12 Product Locator Installation Card

Fill out proper customer information on the Product Locator Installation Card. Refer to ILLUSTRATION 2-7. Mail this Installation Card "Product Locator" to the address corresponding to your pole.

Note

The Product Locator Installation Card shown in ILLUSTRATION 2-7 may not be same as the provided Product Locator card.

	Mailing Address GE Medical Systems Product Locator File P.O. Box 414 Milwaukee, WI 53201-0414					
	DESCRIPTION	FDA	MODEL	REV	SERIAL	
PREPARE FOR ORDERS THAT DO NOT HAVE A LOCATOR INSTALLATION REPORT			OCP	BS	ORD	DATE (MO-DA-YR)
			DIST.-COUNTRY	ROOM		EMPLOYEE NO.
SYSTEM ID NUMBER <div style="border: 1px solid black; height: 20px; width: 100%;"></div>			CUSTOMER NO.			
INSTALLATION			DESTINATION - NAME AND ADDRESS			
PRINTED IN USA INSTALLATION			_____			

			ZIP CODE			

PRODUCT LOCATOR INSTALLATION CARD
ILLUSTRATION 2-7

3-1 INTRODUCTION

This chapter describes system configuration and specifications.

3-2 DIMENSIONS

Regarding LOGIQ™ 400 dimensions, Refer to ILLUSTRATION 3-1 and 3-2, for planning the position of your LOGIQ™ 400.

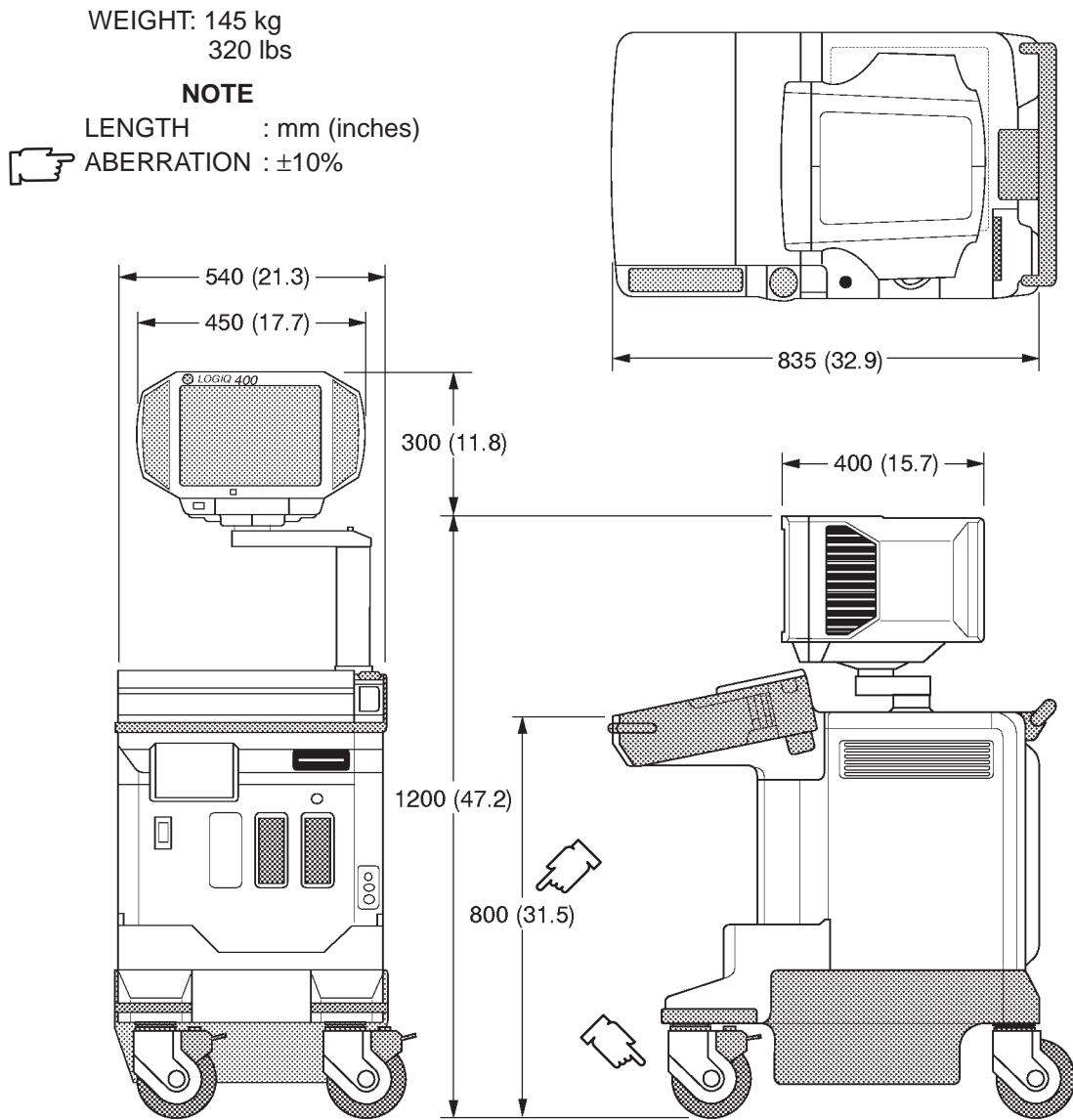

OVERALL DIMENSIONS (Color Monitor Models and B/W Monitor Models with S/W V4.01 or later)

ILLUSTRATION 3-1

3-2 DIMENSIONS (continued)

WEIGHT: 136 kg
300 lbs

NOTE

LENGTH : mm (inches)

ABERRATION : ±10%

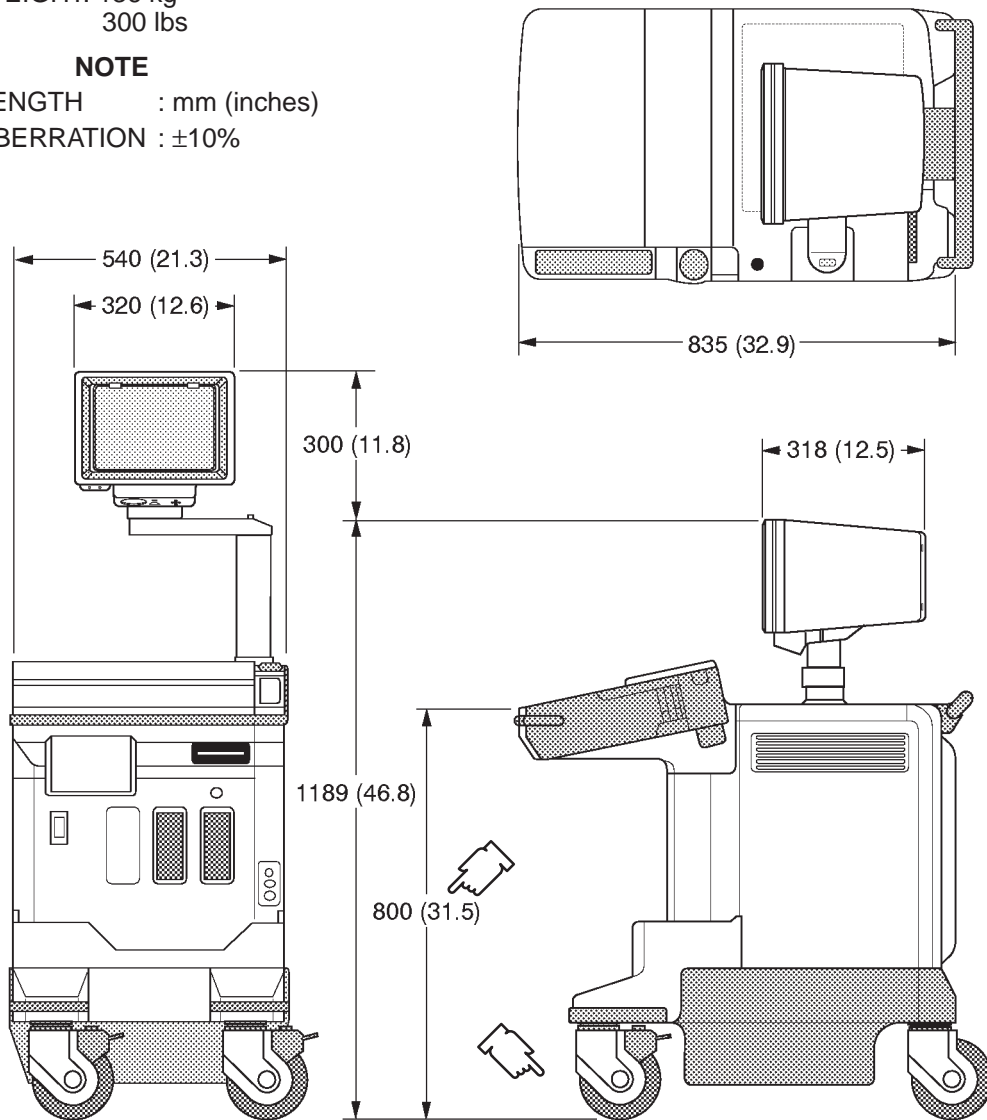

OVERALL DIMENSIONS (B/W Monitor Models with S/W V3.40 or earlier)

ILLUSTRATION 3-2

Note

The ILLUSTRATION 3-2 shows the dimensions for the B/W console with the software version 3.40 or earlier. For the dimensions of the B/W console with the software version 4.01 or later, refer to ILLUSTRATION 3-1.

3-2 DIMENSIONS (continued)

ILLUSTRATION 3-3 shows the dimensions for the LOGIQ™ 400 console with the software version 5.01y or later.

Note

The tall type console is 75mm taller than the normal height console.

WEIGHT: 145 kg
320 lbs

NOTE

LENGTH : mm (inches)
ABERRATION : ±10%

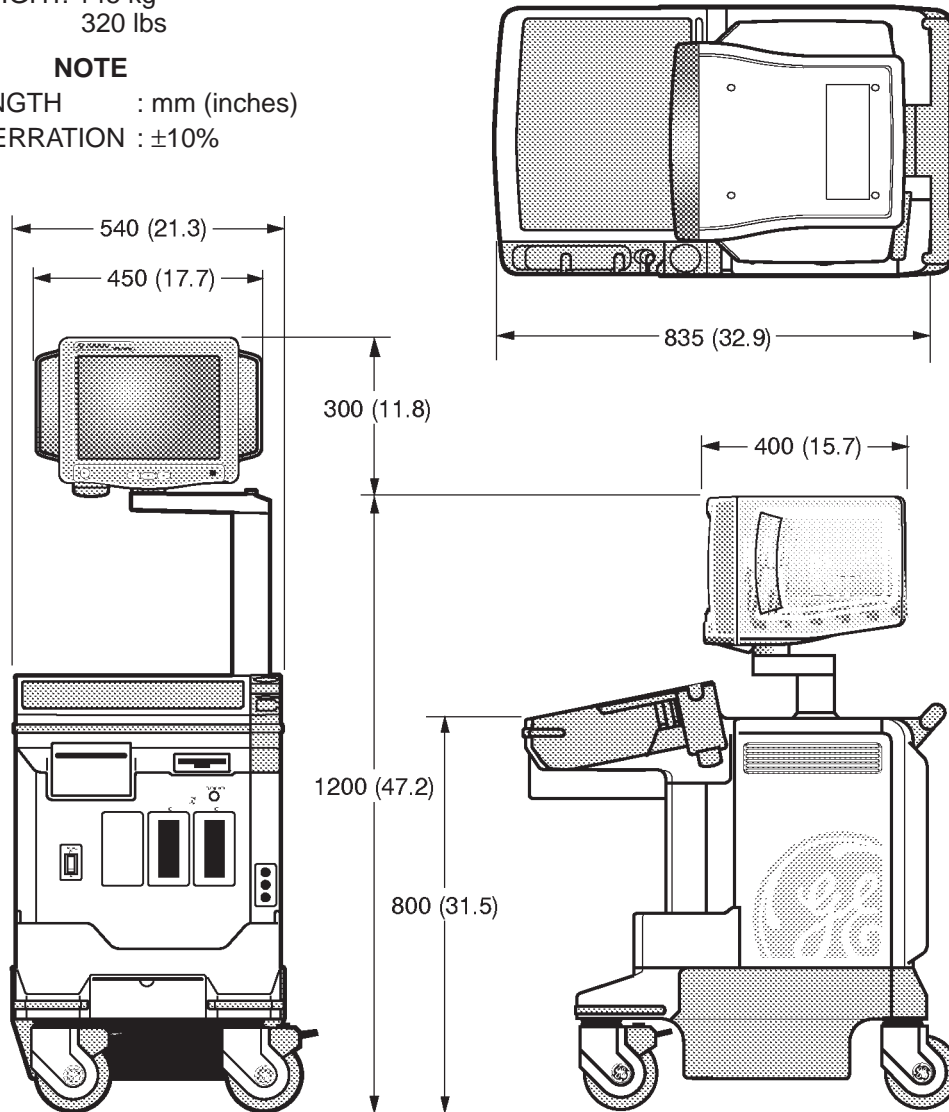

OVERALL DIMENSIONS (15-INCH Monitor Models with S/W V5.01 or later)

ILLUSTRATION 3-3

3-3 ELECTRICAL SPECIFICATIONS

Electrical conduit, junction boxes, outlets, circuit breakers, and switches should be in place before installing the LOGIQ™ 400 console.

3-3-1 Power Supply

Voltage setup is performed in the factory, since different rear panels which contain different power cables and circuit breakers are used for the 100 VAC and 220 VAC versions.

3-3-2 Facility Power Receptacle

A separate power outlet with a 15 amp circuit breaker for 115 VAC units, or a 7.5 amp circuit breaker for 220 VAC units, is recommended. The specific power receptacle used depends on your country's power line standards.

The receptacle should have International Electrotechnical Commission (IEC) approval, or equivalent.

3-4 STORAGE AND OPERATION REQUIREMENTS

The LOGIQ™ 400 is shipped in a single container excluding PROBES. Shipping weight is approximately 395 lbs (179kg) [B/W monitor console: 375lbs (170kg)]. The size of the container is D1100 mm x W660 mm x H1390 mm. (43 in. x 26 in. x 55 in). TABLE 3-1 provides a summary of temperature, atmospheric pressure, and humidity tolerances for shipping, installation, and operation:

TABLE 3-1
STORAGE AND OPERATION REQUIREMENTS

PARAMETER	STORAGE	OPERATION
TEMPERATURE (DEG.C) (DEG.F)	-10 to 60 14 to 140	10 to 40 50 to 104
ATMOSPHERIC PRESSURE (hPa)	700 to 1060	700 to 1060
HUMIDITY (%) (Non-condensing)	30 to 95	30 to 85

3-5 OPTIONAL PERIPHERALS

3-5-1 Peripherals/Accessories Connector Panel

LOGIQ™ 400 peripherals and accessories can be properly connected using the rear connector panel located behind the rear door.

The serial ports for controlling recording devices, video input/output connectors, audio input/output connectors, camera expose connectors, foot switch connector, and power outlet connectors for peripherals are located on the rear panel.

This section indicates the pin assignment for each connector (1-6) in ILLUSTRATION 3-4 at pages 3-7 through 3-8.

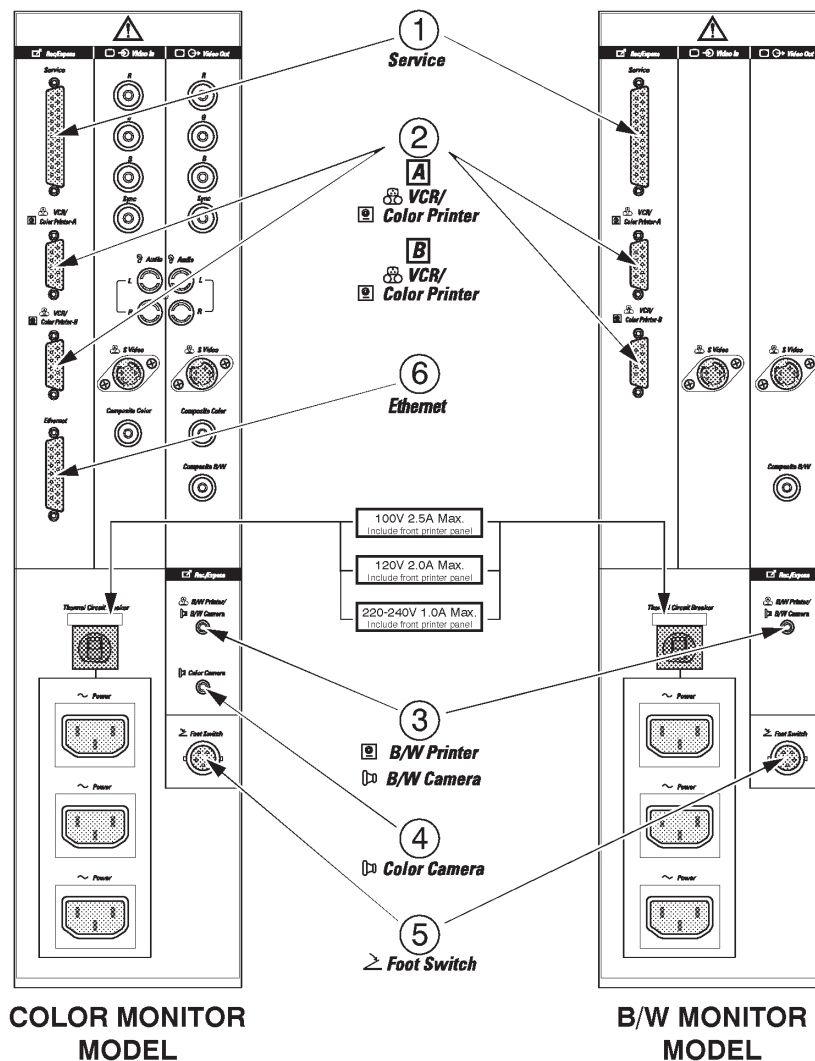

REAR CONNECTOR PANEL
ILLUSTRATION 3-4

Note

The B/W console with the software version 4.01 or later has the same Rear Connector Panel,

3-5-1 Peripherals/Accessories Connector Panel (Continued)

Note

The Ethernet Port (⑥ in ILLUSTRATION 3-4) for the DICOM connection is available on the console with the software version 3.40 or later and the optional DICOM Upgrade Set.

Note

Each outer (case) ground line of peripheral/accessory connectors are protectively grounded. Signal ground lines are Not Isolated, except the Service port (①). All of signal lines (include signal GND) of the Service port are isolated.

① Pin Assignment of RS232C for Service

Connector: Female, D-SUB, 25-pin

Pin No.	Signal	Pin No.	Signal
1		14	
2	TXD	15	
3	RXD	16	
4	RTS	17	
5	CTS	18	
6		19	
7	Signal GND	20	DTR
8	DCD	21	
9		22	
10		23	
11		24	
12		25	
13			

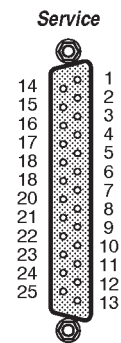

② Pin Assignment of RS232C for VCR/Color Printer (A, B)

Connector: Female, D-SUB, 9-pin

Pin No.	Signal	Pin No.	Signal
1	DCD (+12V)	6	DSR (+12V)
2	RXD	7	RTS
3	TXD	8	CTS
4	DTR (+12V)	9	NC
5	Signal GND		

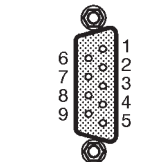

Note

Output level of RS232C signals:

High	+3V to +15V
Low	-15V to 0V

3-5-1 Peripherals/Accessories Connector Panel (Continued)

③ Pin Assignment of Mini Jack for Controlling B/W Printer

Connector: Stereo Mini Jack



Pin No.	Output Signal
1	PRINT *1
2	Signal GND

*1: Printer starts printing by receiving the LOW pulse more than 100ms.

④ Pin Assignment of Mini Jack for Controlling Color Poraloid Camera

Connector: Stereo Mini Jack



Pin No.	Output Signal
1	SHUTTER *2
2	Signal GND

*2: Camera starts printing by receiving the LOW pulse more than 2ms.

⑤ Pin Assignment of Connector for Foot Switch

Connector: Round 5-pin connector

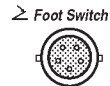

Pin No.	Output Signal
1	FSW1+
2	FSW1-
3	FSW2+
4	FSW2-
5	Frame GND

Note

Output level of control signals indicated in the above tables are TTL level.

3-5-1 Peripherals/Accessories Connector Panel (continued)

⑥ Pin Assignment of Ethernet 

Connector: Male, D-SUB, 15-pin

Pin No.	Signal	Pin No.	Signal
1		9	CN
2	CP	10	TN
3	TP	11	
4		12	RN
5	RP	13	+12V
6	Signal GND	14	
7		15	
8			

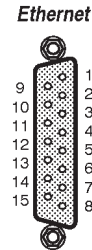

Note

Output level of RS232C signals:

High	+3V to +15V
Low	-15V to 0V

3-5-2 List of Optional Peripherals

The tables below show the optional connectable peripherals for LOGIQ™ 400. Proper remote control and image recording when connecting these peripherals to LOGIQ™ 400, are verified.

1. RECORDING DEVICES

TABLE 3-2
LIST OF RECORDING DEVICES

DEVICE	MANUFACTURER	MODEL	VIDEO SIGNAL
Video Cassette Recorder	SONY	SVO-9500MD	NTSC
	SONY	SVO-9500MDP	PAL
Color Video Printer	SONY	UP-1850MD	NTSC
	SONY	UP-1850EPM	PAL
	SONY	UP-2950MD	NTSC
	SONY	UP-2850P	PAL
	SONY	UP-2900MD	NTSC
	SONY	UP-2800P	PAL
Video Graphic Printer	SONY	UP890MD	NTSC
	SONY	UP890CE	PAL
	SONY	UP890MDG	NTSC/PAL

Note

If the customer need to connect the other peripherals with LOGIQ™ 400 console, please contact the address shown in Chapter 1 of this manual.

Note

The “Quaf-Frm” format is available only for the following color printers:

UP-1850MD, UP-1850EPM, UP-2950MD, and UP-2850P

The “Quaf-Frmls” selection for the Color Printer Memory in the SYSTEM PARAMETER SETUP, is not available for those printers. This function is valid only for the UP-3030MD printer.

3-5-2 List of Optional Peripherals (Continued)

2. CONNECTING CABLES



Equipment damage possibility. Be sure to use the following recommended connecting cables to connect recording devices with LOGIQ™ 400 console.

TABLE 3-3
LIST OF CONNECTING CABLES

NAME	PART NO.	FIGURE	NOTE
POWER CABLE	P9509EE		For recording device
	P9509LH		Used only for installing B/W Video Printer on front of console
RS232C CABLE	P9509MN		For control signals
	2150410		For Insite connection
MINI PLUG CABLE	P9509BE		For control signals (used only for B/W Video Printer)
Ethernet Cable	2195662		For DICOM capability Included in the DICOM Support option with Tranceivers

3-5-2 List of Optional Peripherals (Continued)

3. PROBES

TABLE 3-4
LIST OF TRANSDUCERS

PROBE NAME	MATERIAL OF HEADSHELL	AREA OF USING	TYPE	CATALOG NO.	REQUIRED ADAPTER	FAMILY PROBES	PART No.	
C364	PES	ABDOMINAL	CONVEX	H45202CF	No need	HEAD SHELL IS SAME AS CBF	P9607AB P9607AA	
C551	PES	ABDOMINAL	CONVEX	H45202CE		HEAD SHELL IS SAME AS CAE	P9607AD P9607AC	
E721	PES	INTRACAVITY	CONVEX	H45202MT		HEAD SHELL IS SAME AS MTZ	P9607AF P9607AE	
C721	NORYL	NEONATAL	CONVEX	H45202MN			2121267-2 2121267	
739L	NORYL	SUPERFICIAL	LINEAR	H45202AG			2107460-2 2107460	
L764	PES	SUPERFICIAL	LINEAR	H45202HP		HEAD SHELL IS SAME AS LH	2121377-2 2121377	
S220	PES	CARDIAC	SECTOR	H45202WG		HEAD SHELL IS SAME AS W	2121793-2 2121793	
CBF	PES	ABDOMINAL	CONVEX	H46022CB		PA51		P9603AD P9603AA
CAE	PES	ABDOMINAL	CONVEX	H46022CA				P9603AE P9603AB
MTZ	PES	INTRACAVITY	CONVEX	H46022MT				P9603AU P9603AL
LH	PES	SUPERFICIAL	LINEAR	H46022LH			P9601AS P9601AC	
W	PES	CARDIAC	SECTOR	H4162C	5S			P9600BH P9600BD
546L	NORYL	ABDOMINAL/ SUPERFICIAL	LINEAR	H45202LE	No need		2144266-2 2144266	
S317	NORYL	CARDIAC/ABDOMINAL	SECTOR	H45202SD			2144268-2 2144268	
S611	NORYL	CARDIAC/NEONATAL/ PEDIATRICS	SECTOR	H45202SF			2144267-2 2144267	
C386	NORYL	ABDOMINAL/ OB/GYN	CONVEX	H45202CC			2154186-2 2154186	
I739	NORYL	INTRAOPERATIVE/ INTRACAVITY	LINEAR	H45202JG			2147189-2 2147189	
T739	NORYL	INTRAOPERATIVE	LINEAR	H45202TG			2147188-2 2147188	
LA39	NORYL	SUPERFICIAL	LINEAR	H45202LA			HEAD SHELL IS SAME AS 739L	2155078-2 2155078
B510	PU	CARDIAC	BI-PLANE SECTOR	H45202BT		PA51		2123593 2133115
S222	NORYL	TRANSCRANIAL	SECTOR	H45202TC		No need		2159263 2156263
CWD2	NORYL	CARDIAC	CWD	H45202DB				2123594 2133116
CWD5	NORYL	CARDIAC	CWD	H45202DE			2123595 2133117	

3-5-2 List of Optional Peripherals (continued)

3. PROBES (Continued)

TABLE 3-5
LIST OF TRANSDUCERS (continued)

PROBE NAME	MATERIAL OF HEADSHELL	AREA OF USING	TYPE	CATALOG NO.	REQUIRED ADAPTER	FAMILY PROBES	PART No.
LD	PES	BIOPSY	LINEAR	—	PA 51		— P9601AD
C358	PES	ABDOMINAL	CONVEX	H45202CD			2193617 2172443
ERB7	NORYL	ENDOCAVITY	LINEAR/ CONVEX	H40392LC			2239590 2204232 2252157
 3S	NORYL	CARDIOLOGY	SECTOR	H4550SZ	No Needed		—

Note

PES : Polyethersulfone NORYL : Modified Polyphenylene Oxide PU : Polyurethane

Note

Some probes listed on the table above have two different part numbers. The number of upper row indicates the part number of probes for the region other than Japan. The number of lower row indicates the part number of probes for Japan.

Probes which have only one part number are not available in Japan.

Note

546L, S317, S611, C386, I739, T739 and LA39 probes are available on LOGIQ™ 400 console from software version 3.00.

Note

B510, S222, CWD2 and CWD5 probes are available on LOGIQ™ 400 console from software version 3.10.

Note

The following probes are not available on LOGIQ™ 400CL:

S220, B510, CWD2, CWD5, S317, S611, and S222

Note

The LD probe is available only for the Japanese console with the software version 3.40 or later.

Note

The C358 and ERB7 probes are available on LOGIQ™ 400 console with the software version 4.01 or later.

Note

The 3S probe is available on LOGIQ™ 400 console with the software version 5.01 or later.

3-5-3 Power Consumption of Optional Peripherals

The table below shows the power consumption of each optional peripheral for LOGIQ™ 400.

TABLE 3-6
POWER CONSUMPTION OF OPTIONAL RECORDING DEVICES

DEVICE	MODEL	POWER CONSUMPTION
Video Cassette Recorder	SVO-9500MD	64W
	SVO-9500MDP	
Color Video Printer	UP-1850MD	140W
	UP-1850EPM	
	UP-2950MD	220W
	UP-2850P	(at printing)
	UP-2900MD	180W
	UP-2800P	(at printing)
B/W Video Printer	UP890MD	110W
	UP890CE	
	UP890MDG	120W (at printing)

3-6 VIDEO SPECIFICATIONS

TABLE 3-7
VIDEO SPECIFICATIONS

		12-inch monitor		15-inch monitor	
		NTSC	PAL	NTSC	PAL
Total Line per Frame	[Line]	525	625	525	625
Vertical Frame Frequency	[Hz]	30	25	60	50
Horizontal Scanning Frequency	[kHz]	15.734	15.625	31.469	31.250
Displayed Image Pixels	[mm]	207.0 by 157.3	207.0 by 157.3	239.5 by 180	239.5 by 180
Total Horizontal Line Time	[μs]	63.56	64.00	31.78	32.00
Horizontal Display	[μs]	49.54	48.81	24.77	24.41
Front Porch Width	[μs]	2.76	3.09	1.39	1.54
Sync Pulse Width	[μs]	4.73	4.68	2.36	2.34
Back Porch Width	[μs]	6.53	7.42	3.26	3.71
Total Horizontal Blanking	[μs]	14.02	15.19	7.01	7.59
Vertical Blanking Interval	[H]	31.50	38.50	31.50	38.50
Vertical Front Porch Width	[H]	6.5	9.0	6.5	9.0
Vertical Sync Width	[H]	3	2.5	3	2.5
Vertical Back Porch Width	[H]	22	27	22	27
Pixel Clock	[MHZ]	12.2727	14.7500	24.5454	29.5000
H	[μs]	63.56	64	31.78	32

4-1 INTRODUCTION

This chapter provides procedures for quickly checking major functions of the LOGIQ™ 400 console, diagnostics by using the built-in service software, and power supply adjustments.

4-1-1 Required Equipment



To perform these tests, you'll need any of a sector, linear, or a convex transducer.

Note

The soft menu displayed on the CRT monitor screen disappears automatically by the time set with the CRT Menu Auto Erase Interval of the System Parameter (page 1/6). When the "Inf" is selected, the soft menu does not disappear automatically.

4-2 FUNCTIONAL CHECK PROCEDURES

4-2-1 Basic Controls

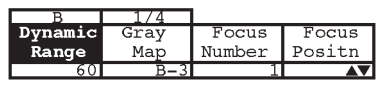



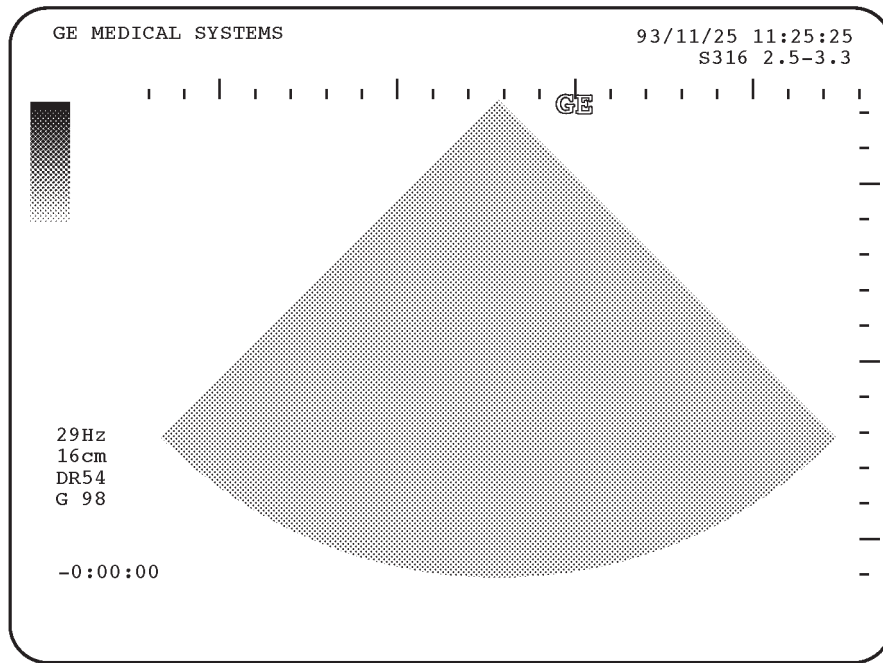





Step	Check	Expected result
1.	Connect a sector or convex transducer to "Probe 2" connector beneath keyboard.	
2.	Turn ON Power toggle switch.	
3.	Type USER ID and then press return key as necessary.	PATIENT ENTRY MENU should appear.
4.	Press New Patient key.	After a few seconds, the B mode screen should appear as shown in ILLUSTRATION 4-1.
5.	Press Top Menu Select key twice. 	The top menu should appear on the CRT monitor screen as follows:  Note  The items displayed on the Top Menu are different depending on the component options.
6.	Select B section using ◀ or ▶ key.	The B selection is displayed in reverse video.
7.	Press ▼ key.	The B mode sub-menu should appear on CRT monitor screen as follows: 
8.	Select Dynamic Range section using ◀ or ▶ key.	The Dynamic Range selection is displayed in reverse video.
9.	Change Dynamic Range up/down using ▲ or ▼ key.	Image grows softer and harder depending on position.
10.	Press Top Menu Select key twice.	The menus on CRT monitor screen should disappear.
11.	Rotate B/M Gain knob.	Image grows lighter and darker with rotation.
12.	Slide TGC potentiometers (pots).	Image grows darker or brighter at depth equivalent to pot's location.
13.	Rotate Depth knob.	The depth of image should be magnified/reduced.
14.	Press Reverse key.	The image reverses the left/right orientation.
15.	Press Reverse key again.	The image reverses the left/right orientation.

4-2-1 Basic Controls (Continued)



B-MODE DISPLAY SCREEN
ILLUSTRATION 4-1

4-2-1 Basic Controls (Continued)

Step	Check	Expected result												
16.	Press M key.	The M mode timeline should appear below the B image as shown in ILLUSTRATION 4-2. Whether it takes half the screen or two-thirds depends on the preset.												
17.	Roll trackball.	The M mode cursor should follow trackball movement and the timeline should update for new location of focus.												
18.	Press Scan Area key.	The indicator LED located at the left side of the Scan Area key should be ON and the color of the M mode cursor should change.												
19.	Roll trackball.	The width of B mode image should change wider or narrower.												
20.	Press M/D Cursor key.	The indicator LED located at the left side of the M Cursor key should be ON and the M mode cursor should become active again.												
21.	Press Top Menu Select key twice. 	The top menu should appear on the CRT monitor screen as follows:  Note  The items displayed on the Top Menu are different depending on the component options.												
22.	Select M section using  or  key.	The M selection is displayed in reverse video.												
23.	Press  key.	The M mode sub-menu should appear on CRT monitor screen as follows: <table border="1" data-bbox="738 1270 1104 1354"> <tr> <td>M</td> <td>1/2</td> <td>Rejectn</td> <td>Edge</td> </tr> <tr> <td>Dynamic Range</td> <td>Gray Map</td> <td></td> <td>Enhance</td> </tr> <tr> <td>60</td> <td>M-1</td> <td>OFF</td> <td>MID</td> </tr> </table>	M	1/2	Rejectn	Edge	Dynamic Range	Gray Map		Enhance	60	M-1	OFF	MID
M	1/2	Rejectn	Edge											
Dynamic Range	Gray Map		Enhance											
60	M-1	OFF	MID											
24.	Select Edge Enhance section using  or  key.	The Edge Enhance selection is displayed in reverse video												
25.	Change M Edge Enhance up/down using  or  key.	Changes the M-Mode image.												
26.	Press Top Menu Select key twice.	The menus on CRT monitor screen should disappear.												

4-2-1 Basic Controls (Continued)

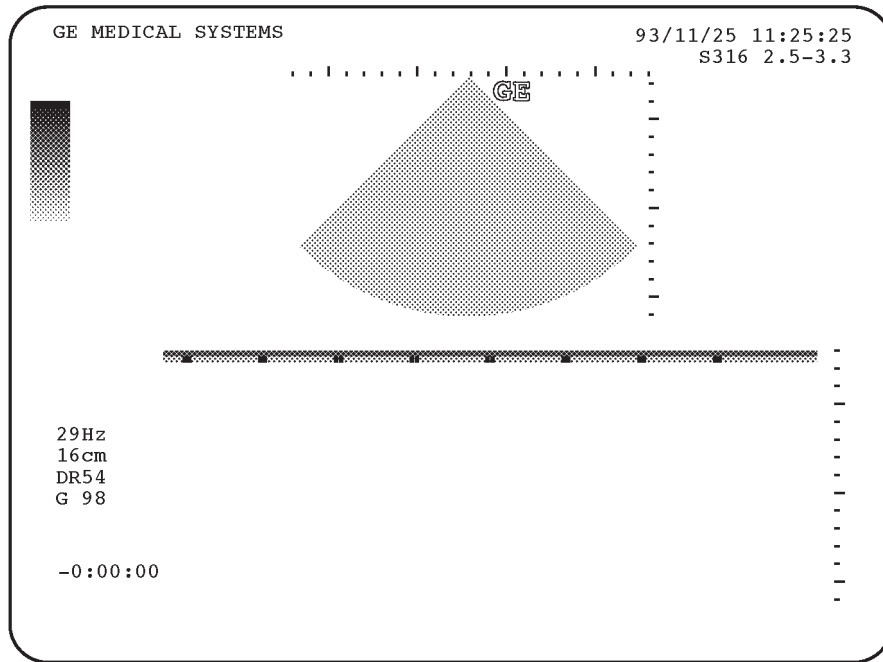

M-MODE DISPLAY SCREEN
ILLUSTRATION 4-2

Note

You can select the two types of display format: Side by Side (with the 2-D display to the left of the M-mode display) and Top/Bottom (with the 2-D display on top of the M-mode display) by using the Preset Menu. For the Preset Menu, refer to Customizing Your System in the LOGIQ™ 400 User Manual.

4-2-1 Basic Controls (Continued)

Step	Check	Expected result
27.	Press B key.	The B mode screen should appear as shown in ILLUSTRATION 4-1.
28.	Press CFM key.	The CFM mode screen should appear as shown in ILLUSTRATION 4-3.
29.	Rotate Gain knob	Color image noise should appear.
30.	Press Freeze key.	The image should freeze.
31.	Rotate Cine Scroll knob.	The Cine gauge should appear under the B mode image.
32.	Press Freeze key again.	The image revives acquisition and the Cine gauge should disappear.
33.	Press CFM key again.	The B mode screen should appear as shown in ILLUSTRATION 4-1.

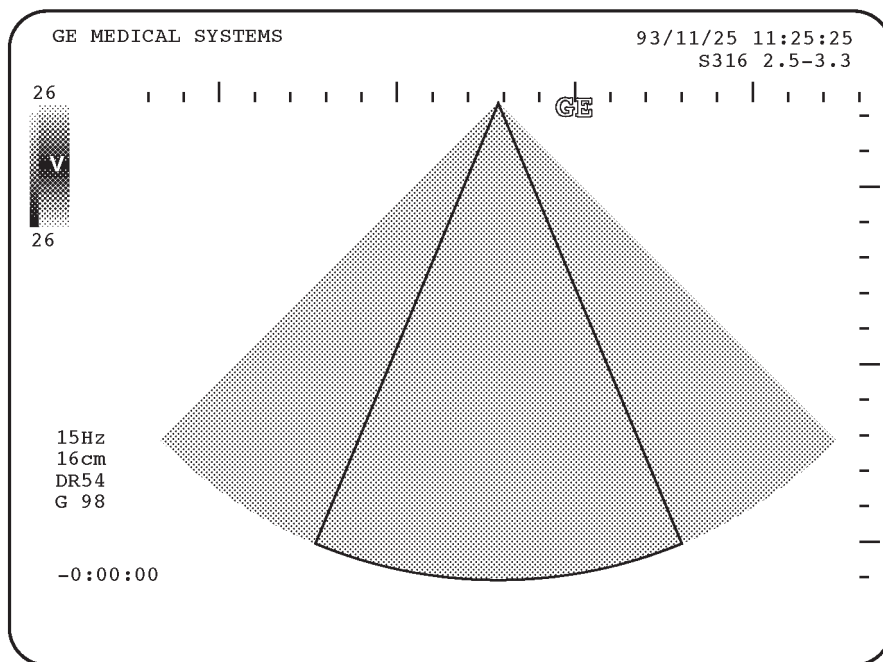

CFM MODE DISPLAY SCREEN
ILLUSTRATION 4-3

Note

You can select the four types of CFM window: Survey, Survey Detail, Map, and Map Detail by using the CUSTOM DISPLAY Preset Menu. For the CUSTOM DISPLAY Preset Menu, refer to Customizing Your System in the LOGIQ™ 400 User Manual.

4-2-1 Basic Controls (Continued)

Step	Check	Expected result
34.	Press PD key.	The Pulse Doppler mode screen should appear as shown in ILLUSTRATION 4-4.
35.	Rotate θ Angle knob.	A line should appear in the circle on the B mode image and that line displayed with circle should rotate.
36.	Rotate Gain knob.	The Doppler noise should increase/decrease.
37.	Rotate Audio Volume knob.	The Doppler audio volume should increase/decrease.
38.	Press B key.	The B mode screen should appear as shown in ILLUSTRATION 4-1.

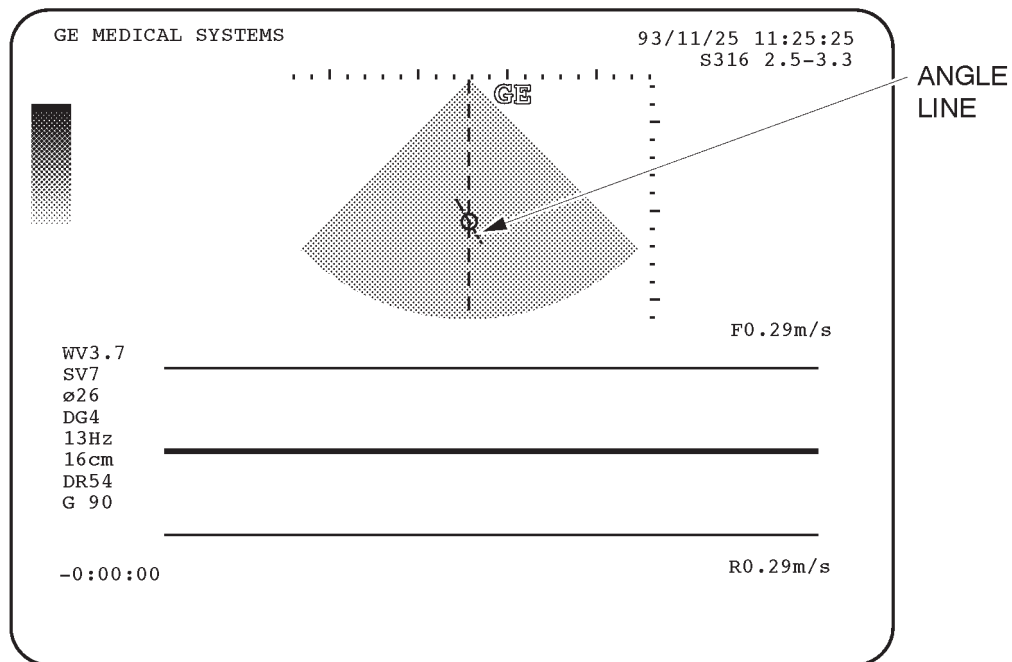

PULSE DOPPLER MODE DISPLAY SCREEN
ILLUSTRATION 4-4

Note

You can select the two types of display format: Side by Side (with the 2-D display to the left of the PD-mode display) and Top/Bottom (with the 2-D display on top of the PD-mode display) by using the Preset Menu. For the Preset Menu, refer to Customizing Your System in the LOGIQ™ 400 User Manual.

4-3 DIAGNOSTICS

4-3-1 Service Software Menu

1. Press the Top Menu Select key located on the keyboard twice.

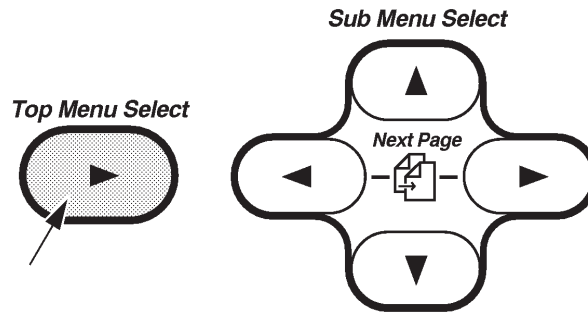

SOFTWARE MENU CONTROL KEYS
ILLUSTRATION 4-5

The top menu is displayed on CRT monitor screen as shown in ILLUSTRATION 4-6.



TOP MENU
ILLUSTRATION 4-6

Note

The items displayed on the Top Menu are different depending on the component options.

2. Select the Set Up Menu using the ◀ or ▶ key of Sub Menu Select keys on the keyboard. The Set Up selection is displayed in reverse video as shown in ILLUSTRATION 4-6.
3. Press ▼ key to select the Set Up Menu. The Set Up Menu is displayed on the CRT monitor screen as shown in ILLUSTRATION 4-7.

Set Up	1/1					
Custom Display	System Paramtr	Preset Program	Save Values	Utility	User Define	Diag.
▼▲	▼▲	▼▲	▼▲	▼▲	▼▲	▼▲

SET UP MENU
ILLUSTRATION 4-7

4. Select the Diag. section using the ◀ or ▶ key and press ▼ key to use the User Diagnostics function. The Diagnosis Menu is displayed on the CRT monitor screen. Refer to ILLUSTRATION 4-8. Select the Utility section using the ◀ or ▶ key and press ▼ key to use User Utility function. The Utility Menu is displayed on the CRT monitor screen. Refer to ILLUSTRATION 4-13.

4-3-2 Diagnosis Test Menu

Select the Diag. section using the ◀ or ▶ key and press ▼ key to use the User Diagnostics function. The Diagnosis Menu is displayed on the CRT monitor screen as shown in ILLUSTRATION 4-8.

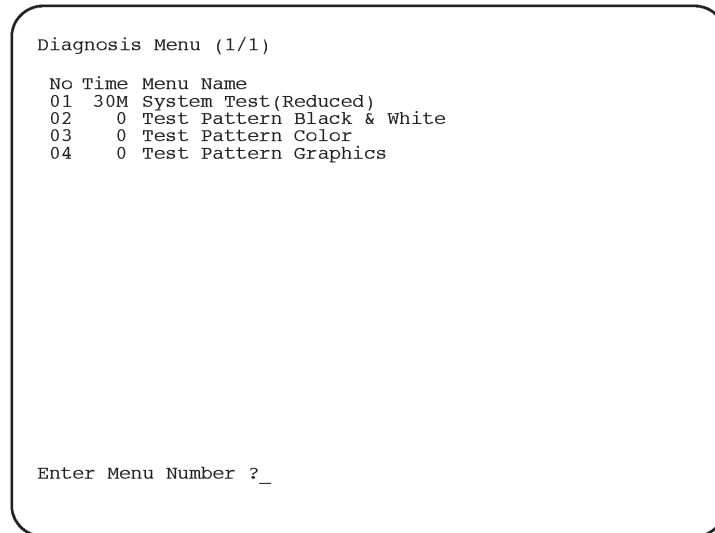

DIAGNOSIS TEST MENU

ILLUSTRATION 4-8

Note

Press and hold the **Control** key and press **R** to display the previous menu in the User Diagnostics mode.

4-3-2 Diagnosis Test Menu (Continued)

(A) SYSTEM TEST 1

Make sure that one or more probes are connected with console before executing the following system test.

Type 1 and then press the Return key when the Diagnosis Test Menu is displayed. The system test will start automatically. After checking each test item, "Passed" or "Failed" is displayed depending on the actual test result.

```

System Test (Reduced) (1/1)

No Test Name
03 Beam Former Test1                Not Tested
04 Beam Former Test2                Not Tested
05 Log Test                          Passed
06 Frequency Characteristics Test    Passed
08 Doppler Test1                    Passed
09 Doppler Test2                    Passed
11 Color Flow Test1                 Passed
12 Color Flow Test2                 Passed
13 Time Line Memory Test (Reduced)   TLMC Passed
14 Scan Convertor Memory Test (Reduced) DSCC Passed
15 CINE Memory Test (Reduced)       TLMC Passed
16 Video Memory Test (Reduced)      VIDO Passed
17 VCR Playback Memory Test (Reduced) Passed
18 Graphic Memory Test (Reduced)    Passed
19 BMRC Memory Test (Reduced)       Passed
20 PIOP Test                         Passed
21 Keyboard RAM Test (Reduced)       Passed
27 Power Supply & Thermal Test      Running
29 B Mode Noise Floor Test
30 D Mode Noise Floor Test
31 CFM Mode Noise Floor Test
    
```

SYSTEM TEST 1
ILLUSTRATION 4-9

The system beeps three times after checking all the tests.

If system does not pass the diagnostic test, please contact the qualified service engineer in your area. Please refer to Chapter 1 of this manual for the appropriate address/phone number to contact service.

4-3-2 Diagnosis Test Menu (Continued)**(B) TEST PATTERN BLACK & WHITE**

The black & white pattern permits the serviceman to accurately adjust the contrast of an optional equipment (such as a camera) to see the details in the lightest and darkest areas of the image.

Type **2** and then press Enter key when the Diagnosis Menu is displayed. The Test Pattern Black & White is displayed as shown in ILLUSTRATION 4-10.

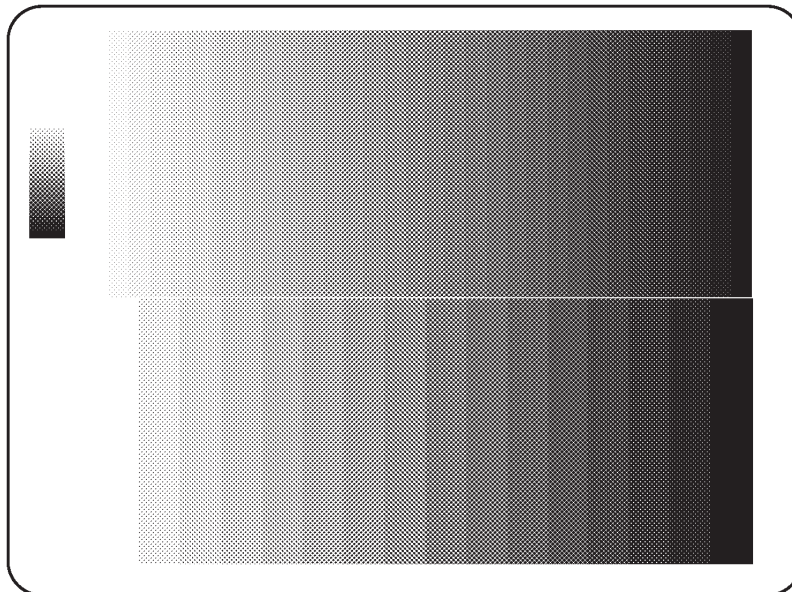

TEST PATTERN BLACK & WHITE
ILLUSTRATION 4-10

4-3-2 Diagnosis Test Menu (Continued)

(C) TEST PATTERN COLOR

The color scale permits the serviceman to adjust the color contrast of an optional equipment (such as a color video printer).

Type **3** and then press Enter key when the Diagnosis Menu is displayed. The Test Pattern Color is displayed as shown in ILLUSTRATION 4-11.

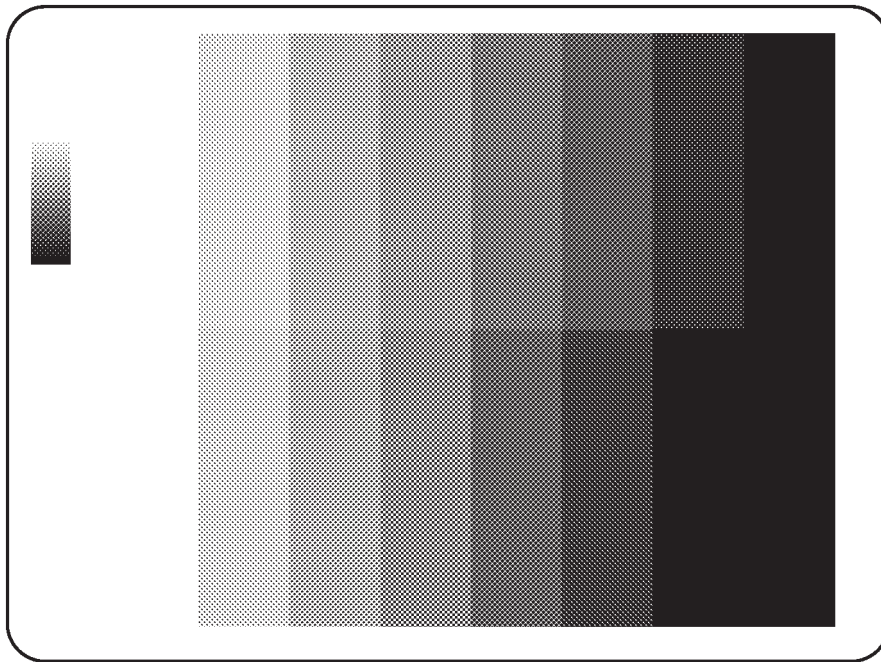

TEST PATTERN COLOR
ILLUSTRATION 4-11

Note

In case of B/W monitor system, this function is invalid. The message "Not tested" is displayed on the CRT monitor screen when the option number 3, Test Pattern Color is selected.

4-3-2 Diagnosis Test Menu (Continued)

(D) TEST PATTERN GRAPHICS

The vertical linearity and graphics perimeter pattern should be centered on the optional equipment display. This ensures all whitescale graphics overlays will be visible.

Type **4** and then press Enter key when the Diagnosis Menu is displayed. The Test Pattern Graphics is displayed as shown in ILLUSTRATION 4-12.

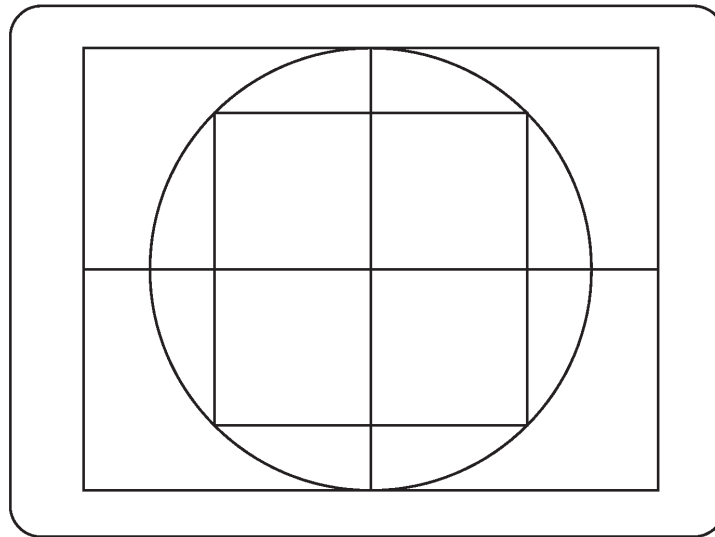

TEST PATTERN GRAPHICS
ILLUSTRATION 4-12

4-3-3 Utility Menu

Select the Utility section using the ◀ or ▶ key and press ▼ key to use the User Utility function. The Utility Menu is displayed on the CRT monitor screen as shown in ILLUSTRATION 4-13.

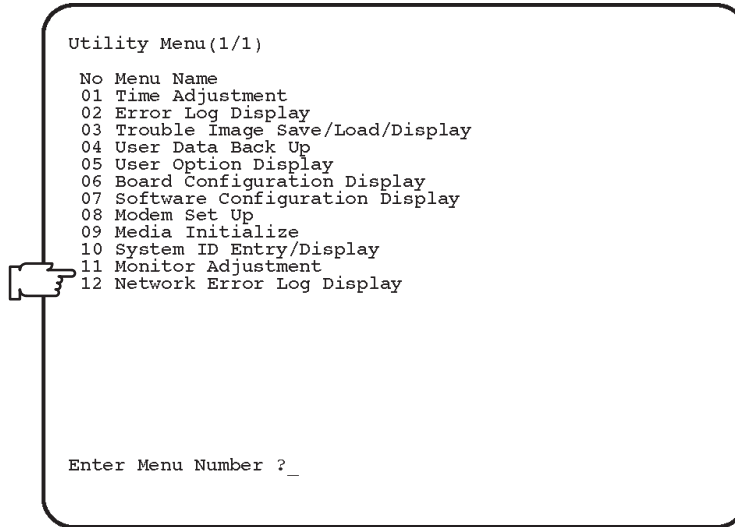

UTILITY MENU
ILLUSTRATION 4-13

Note

Press and hold the **Control** key and press **R** to display the previous screen in the User Utility mode.

Note

Item 12 (for V4.01, V4.02 or later) and item 11 (for V3.40 or V3.41), Network Error Log Display is the additional function for the console with the software version 3.40 or later. This menu is displayed and available only when the Storage/Print DICOM option is enabled.

Note

Item 11, Monitor Adjustment is available on the console with the software version 4.01 or later.

4-3-3 Utility Menu (Continued)

(A) TIME ADJUSTMENT

This changes the current time in the system.

Type 1 and then press Enter key when the Utility Menu is displayed. The system date and time previously set is displayed as shown in ILLUSTRATION 4-14.

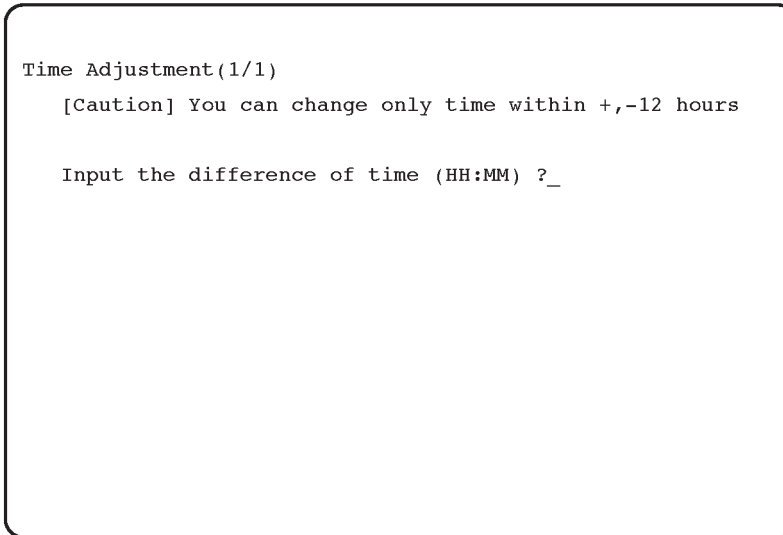

TIME ADJUSTMENT SCREEN
ILLUSTRATION 4-14

Procedure

1. Input the time difference using the numeric keys on keyboard and then press <Enter>. The input format for the time is "HH:MM". You can change the current time within ± 12 hours

Note

Put a "-" character in front of the time difference to decrease the current time.

After changing the current time, the Utility Menu reappears on the CRT monitor.

4-3-3 Utility Menu (Continued)

(B) ERROR LOG DISPLAY

This loads and displays an error log file, or saves it into the MO (Magneto Optical) disk.

Type **2** and then press **Return** key when the Utility Menu is displayed. The Error Log Display is displayed as shown in ILLUSTRATION 4-15.

```

Error Log Display(1/1)
001 1995/06/27 18:27
    SYS ERROR: BUS ERROR.      PC:      0 AD:      0
002 1995/06/27 19:03
    SYS ERROR: BUS ERROR.      PC:      0 AD:      0
003 1995/06/28 09:51
    SYS ERROR: BUS ERROR.      PC:      0 AD:      0
004 1995/06/30 12:15
    SYS ERROR: BUS ERROR.      PC:      0 AD:      0
005 1995/07/03 20:13
    SYS ERROR: BUS ERROR.      PC:      0 AD:      0
006 1995/07/08 15:20
    SYS ERROR: BUS ERROR.      PC:      0 AD:      0
007 1995/07/08 18:26
    SYS ERROR: BUS ERROR.      PC:      0 AD:      0
008 1995/07/08 21:11
    SYS ERROR: BUS ERROR.      PC:      0 AD:      0
009 1995/07/09 10:44
    SYS ERROR: BUS ERROR.      PC:      0 AD:      0

Do you copy this file ? (Y/N)

```

ERROR LOG FILE DISPLAY
ILLUSTRATION 4-15

Procedure for Saving File

1. Type **Y** and then press **Return** key.
2. Insert an 128MB MO (Magneto Optical) disk (or 230MB disk for the console with software version 3.10 or later) into the MOD drive of console and press any key.

Note

Use new initialized MO disk. It is impossible to save the error log file into the disk which another file is already stored.

Note

The 230MB MO disk is available on the console with software version 3.10 or later.

During the time that the system is saving the error log file, "Copying now" is displayed on the CRT monitor.

4-3-3 Utility Menu (Continued)

(C) TROUBLE IMAGE SAVE/LOAD/DISPLAY

This saves the trouble image recorded in the Hard Disk into the MO (Magneto Optical) Disk. This also loads the image data saved in the MO Disk into the Hard Disk and displays the trouble image selected on the CRT monitor by using the image recall function.

Note

Press and hold the **Control** key and press **W** to save the trouble image into the hard disk. You can save the maximum 8 images into the hard disk.

Note

To save the trouble image into the hard disk, the optional VIPB Assy must be installed on the console instead of VIDO Assy. Otherwise, the message "This function is not available." will be displayed on the CRT monitor screen.

Type **3** and then press Return key when the Utility Menu is displayed. The following screen is displayed.

```

Trouble Image Save/Load/Display
  1:Save  2:Load  3:Display
Enter Menu Number ?
Set a media to drive and then press any key.
    
```



```

Trouble Image Save/Load/Display
  1:Save  2:Load  3:Display
Enter Menu Number ?
Set a media to drive and then press any key.

No  Data Name   Date           Time           Mode           (1/2)
01  DIAGIG00.VC  1995/06/20    12:12          No Image
02  DIAGIG01.VC  1995/06/20    12:13          B
03  DIAGIG02.VC  1995/06/20    12:14          C,B
04  DIAGIG03.VC  1995/06/20    12:15          B/B

Enter Menu Number ?_
    
```

TROUBLE IMAGE SAVE/LOAD/DISPLAY (a)
ILLUSTRATION 4-16

4-3-3 Utility Menu (Continued)

(C) TROUBLE IMAGE RECORD & DISPLAY (Continued)

Procedure for Saving Trouble Images

1. Type **1** and then press **Return** key. The message "Set a media to drive and then press any key." is displayed.
2. Set an 128MB MO (Magneto Optical) disk (or 230MB disk for the console with software version 3.10 or later) into the MOD drive and press any key. The Trouble Image File Menu will be displayed on the CRT monitor screen. Refer to ILLUSTRATION 4-16.

Note

Use new initialized MO disk. It is impossible to save any trouble image files into the disk which another file is already stored.

Note

The 230MB MO disk is available on the console with software version 3.10 or later.

3. Input the file number you desire to save into the MO disk.
4. Press Return key.

During the system is saving the file, "Saving now" is displayed on the CRT monitor. After saving the file, "Succeeded" or "Failed" is displayed on the CRT monitor. Then, the message "Press Y to continue, Control + R to quit" is displayed. Type **Y** and press **Return** to continue to use this function. Press and hold the **Control** key, and press **R** to quit this function.

Procedure for Loading Trouble Images

1. Type **2** and then press **Return** key. The message "Set a media to drive and then press any key." is displayed.
2. Set an 128MB MO (Magneto Optical) disk (or 230MB disk for the console with software version 3.10 or later) into the MOD drive and press any key. The Trouble Image File Menu will be displayed on the CRT monitor screen. Refer to ILLUSTRATION 4-16.

Note

The 230MB MO disk is available on the console with software version 3.10 or later.

3. Input the file number you desire to load from the MO disk.
4. Press **Return** key.

During the system is loading the file, "Loading now" is displayed on the CRT monitor. After saving the file, "Succeeded" or "Failed" is displayed on the CRT monitor. Then, the message "Press Y to continue, Control + R to quit" is displayed. Type **Y** and press **Return** to continue to use this function. Press and hold the **Control** key, and press **R** to quit this function.

4-3-3 Utility Menu (Continued)

(C) TROUBLE IMAGE RECORD & DISPLAY (Continued)

Procedure for Displaying Trouble Images

1. Type **3** and then press **Return** key. The Trouble Image File Menu will be displayed on the CRT monitor screen. Refer to ILLUSTRATION 4-16.
2. Input the file number you desire to display on the CRT monitor screen.
3. Press **Return** key.

Press and hold the **Control** key and press **Q** to display the Trouble Image Menu on the CRT monitor screen.

4-3-3 Utility Menu (Continued)

(D) USER DATA BACK UP

This saves the user preset data into the MO disk. This also loads the user preset data stored in the MO disk. System Parameter, Probe Parameter, and the User Table into the external recording media.

Note

The user preset data is different depending on each category.
You can select the user preset data from among the following menu.

1. System Data
2. Application (Rad/Abdomen) Data
3. Application (Obstetrics) Data
4. Application (Gynecology) Data
5. Application (Cardiology) Data
6. Application (Vascular) Data
7. Application (Ulorogy) Data
8. Application (Small Parts) Data
9. All System & Application Data

System data includes:

System Preset Data File, User Define Data File*, VCR Registration Information Data File*, VCR Patient Information Data File*, and Image Archive Search Data File*

Each application data includes:

Application Preset Data File, Probe Preset Data File, Report Format Data File, OB Table Data File, Fetal Trend Patient Data File*, and Cardiac Calc. Auto Sequence Data File*

The files with the symbol "*" listed above are saved only when the software options are installed and any files are stored in the hard disk.

Note

The 230MB MO disk is available on the console with software version 3.10 or later.

4-3-3 Utility Menu (Continued)

(D) USER DATA BACK UP (Continued)

Type **4** and then press **Return** key when the Utility Menu is displayed. The User Data Back Up Menu is displayed as shown in ILLUSTRATION 4-17.

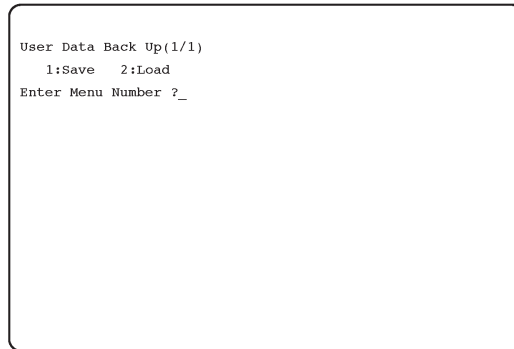

USER DATA BACK UP MENU
ILLUSTRATION 4-17

Note

You cannot save two or more items into one MO disk. If you want to save two or more items of the User Data Menu into one MO disk, Choose the item 09, All System & Application Data.

Procedure for Saving User Data

1. Type **1** and then press the **Return** key. The message “Set a media to drive and then press any key” is displayed.
2. Insert an initialized 128MB MO (Magneto Optical) disk (or 230MB disk for the console with software version 3.10 or later) into the MOD drive of console and press the Return key. The User Data Menu is displayed on the CRT monitor screen as shown in ILLUSTRATION 4-18.

Note

Use new initialized MO disk. It is impossible to save any user data files into the disk which another file is already stored.

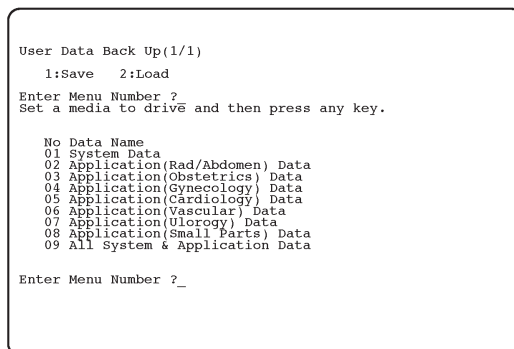

USER DATA MENU
ILLUSTRATION 4-18

4-3-3 Utility Menu (Continued)

(D) USER DATA BACK UP (Continued)

3. Input the file number you desire to save into the MO disk.
4. Press **Return** key. The system starts saving.

During the system is saving data, "Saving now" is displayed on the CRT monitor. After saving data, "Succeeded" or "Failed" is displayed on the CRT monitor. Then, the message "Press Y to continue, Control + R to quit" is displayed. Type **Y** and press **Return** key to continue to use this function. Press and hold **Control**, and press **R** to quit this function.

Procedure for Loading User Data

1. Type **2** and then press the **Return** key. The message "Set a media to drive and then press any key" is displayed.
2. Insert an initialized 128MB MO (Magneto Optical) disk (or 230MB disk for the console with software version 3.10 or later) into the MOD drive of console and press the **Return** key. The User Data Menu is displayed on the CRT monitor screen. Refer to ILLUSTRATION 4-18.
3. Input the file number you desire to load from the MO disk.
4. Press **Return** key. The system starts loading.

During the system is loading data, "Loading now" is displayed on the CRT monitor. After loading data, "Succeeded" or "Failed" is displayed on the CRT monitor. Then, the message "Press Y to continue, Control + R to quit" is displayed. Type **Y** and press **Return** key to continue to use this function. Press and hold **Control**, and press **R** to quit this function.

Note

After loading User Data, turn the system power OFF. Then, turn the system power ON again after completing the power off process.

4-3-3 Utility Menu (continued)

(E) USER OPTION DISPLAY

This displays the option names and the current status for each option.

Type **5** and then press **Return** key when the Utility Menu is displayed. The User Option Display is displayed as shown in ILLUSTRATION 4-19.



USER OPTION DISPLAY
ILLUSTRATION 4-19

Note

The status of options indicated on the user option display is different depending on the system configuration.

Note

This function can only display the option names. It is not possible for the user to change the option settings.

Note

The following three options are not available on the LOGIQ™ 400CL systems.

- Item 09: Phased Array Sector Probe
- Item 17: Heading VCR Playback
- Item 21: Advanced Cardiac Calculation

4-3-3 Utility Menu (continued)**(E) USER OPTION DISPLAY** (continued)**Note**

The following four (4) options are available only for the console with the software version 3.00 or later:

- Item 25: Multigestation calculation
- Item 26: Advanced Vascular Calculation
- Item 27: CFM/PDI Enhancement
- Item 28: MD Startup Display

The item 28, "MD Startup Display" is changed to "CL Startup Display" for the LOGIQ™ 400CL systems.

Note

The following four (4) options are available only for the console with the software version 3.40 or later:

- Item 29: 3DvieW-1
- Item 30: 3DvieW-2
- Item 31: Storage/Print (DICOM)
- Item 32: Worklist (DICOM)

Note

The following three (3) options are available only for the console with the software version 4.01 or later:

- Item 33: ACE-2
- Item 34: Realtime Doppler Calculation
- Item 35: MR3 Startup Display

Note

The ATO option (Item# 36) is not available on the console with the software version 4.01 and 4.02.

Note

The following four (4) options are available only for the console with the software version 5.01 or later:

- Item 36: ACE-2
- Item 37: Realtime Doppler Calculation
- Item 38: MR3 Startup Display
- Item 39: CL Startup Display

4-3-3 Utility Menu (Continued)

(F) BOARD CONFIGURATION DISPLAY

This displays the configurations of all P. C. boards installed in the console. This also displays the version and capacity of memory (only operator usable memory) for each installed board.

Type **6** and then press **Return** key when the Utility Menu is displayed. The Board Configuration Display is displayed as shown in ILLUSTRATION 4-20.

```
Board Configuration Display (1/1)
No  Board Name  Version  Status  Memory (kb)
01  MOTHER      -----  Not Checked  -----
02  PRAG        -----  Not Checked  -----
03  CONN(1)     -----  Not Installed -----
04  DCON        -----  Not Checked  -----
05  MASC        0         Installed    -----
06  VIDO        4         Installed    -----
07  VIPB        0         Not Installed -----
08  VIDM        0         Not Installed -----
09  CINE        1         Installed    40960
10  DSCC        4         Installed    -----
11  TLMC        1         Installed    -----
12  TDCB        0         Not Installed -----
13  DOPC        1         Installed    -----
14  BMRC        0         Installed    -----
15  ASPR        4         Installed    -----
16  PIOP        0         Not Installed -----
17  TRDR        80        Installed    -----
18  HBFR(1)     0         Installed    -----
19  HBFR(2)     0         Installed    -----
```

Sample Display for Console with
Software Version 2.11

```
Board Configuration Display (1/1)
No  Board Name  Version  Status  Memory (kb)
01  MOTHER      -----  Not Checked  -----
02  PRAG        -----  Not Checked  -----
03  CONN(1)     -----  Not Installed -----
04  DCON        -----  Not Checked  -----
05  MASC        0         Installed    -----
06  VIDO        4         Installed    -----
07  VIPB        0         Not Installed -----
08  VIDM        0         Not Installed -----
09  CINE        1         Installed    40960
10  DSCC        4         Installed    -----
11  TLMC        1         Installed    -----
12  TDCB        0         Not Installed -----
13  DOPC        4         Installed    -----
14  BMRC        0         Installed    -----
15  ASPR        4         Installed    -----
16  PIOP        0         Not Installed -----
17  TRDR        4         Installed    -----
18  HBFR(1)     0         Installed    -----
19  HBFR(2)     0         Installed    -----
20  STCG        -----  Not Installed -----
```

Sample Display for Console with
Software Version 3.00

```
Board Configuration Display (1/1)
No  Board Name  Version  Status  Memory (kb)
01  MOTHER      -----  Not Checked  -----
02  PRAG        -----  Not Checked  -----
03  CONN(1)     -----  Installed     -----
04  DCON        -----  Not Installed -----
05  MASC        0         Installed    -----
06  VIDO        9         Not Installed -----
07  VIPB        5         Installed    -----
08  VIDM        6         Not Installed -----
09  CINE        0         Installed    8192
10  DSCC        9         Installed    -----
11  TLMC        5         Installed    -----
12  TDCB        5         Not Installed -----
13  DOPC        4         Installed    -----
14  BMRC        0         Installed    -----
15  ASPR        8         Installed    -----
16  PIOP        2         Installed    -----
17  TRDR        4         Installed    -----
18  HBFR(1)     0         Installed    -----
19  HBFR(2)     0         Installed    -----
20  STCG        -----  Installed    -----
21  DCWD        -----  Installed    -----
```

Sample Display for Console with
Software Version 3.10 or Later

BOARD CONFIGURATION DISPLAY
ILLUSTRATION 4-20

Note

The board configuration and version of each board indicated on the board configuration display is different depending on the style of console.

4-3-3 Utility Menu (Continued)

(G) SOFTWARE CONFIGURATION DISPLAY

This displays the configurations of all system software installed in the console.

Type **7** and then press **Return** key when the Utility Menu is displayed. The Software Configuration Display is displayed as shown in ILLUSTRATION 4-21.

Software Configuration Display(1/3)

No	Software	Date	V/R=03.10
01	BOOT.LO	1996/10/31 13:49	
02	RTLIB.LO	1996/12/12 21:35	
03	VTSH.LO	1996/12/16 16:19	
04	KRNL03.LO	1995/02/27 22:34	
05	KRNL02.LO	1994/12/21 18:46	
06	KRNL01.LO	1994/12/21 17:05	
07	KRNL00.LO	1994/12/21 16:56	
08	BEND.LO	1996/12/19 18:29	
09	DSPI.LO	1996/12/10 16:28	
10	CMNC.LO	1996/08/08 10:33	
11	PIFC.LO	1996/12/19 15:42	
12	MESC.LO	1996/12/27 16:42	
13	IIPC.LO	1996/12/27 18:17	
14	IMDC.LO	1996/12/19 11:56	
15	STRC.LO	1996/12/26 13:18	
16	SCNI.LO	1997/01/06 11:20	
17	PRTM.LO	1996/04/10 02:05	
18	RTSH.LO	1996/12/16 16:40	

Software Configuration Display(2/3)

No	Software	Date	V/R=03.10
19	VCRD.LO	1996/05/15 16:53	
20	PLCD.LO	1996/04/10 02:08	
21	MICD.LO	1996/04/10 02:08	
22	PWRD.LO	1996/07/08 14:47	
23	CLPD.LO	1996/04/10 02:08	
24	BWPD.LO	1996/04/10 02:08	
25	RCDI.LO	1996/10/14 18:51	
26	RCDC.LO	1996/12/27 13:33	
27	PRSC.LO	1996/12/24 03:41	
28	VPBD.LO	1996/12/06 11:49	
29	ISTI.LO	1996/06/06 20:32	
30	KRMT.LO	1996/05/13 21:35	
31	SVSC.LO	1996/12/13 21:56	
32	TPFT.LO	1996/12/27 14:02	
33	OBCC.LO	1996/12/24 14:00	
34	ACCC.LO	1996/12/20 09:54	
35	BCCC.LO	1996/12/13 22:15	
36	AVCC.LO	1996/12/07 01:15	

Software Configuration Display(3/3)

No	Software	Date	V/R=03.10
37	CSMD.LO	1996/12/18 16:41	
38	PCID.LO	1996/05/29 13:13	
39	IMAD.LO	1996/12/27 15:25	
40	GVCC.LO	1996/12/13 22:11	
41	XMDM.LO	1996/06/21 12:24	
42	DDIC.LO	1996/12/26 21:45	
43	DDOC.LO	1996/12/19 18:00	
44	AKSV.LO	1997/01/02 15:48	
45	DFEL.LO	1997/01/02 15:15	
46	NBOT.LO	1996/12/24 18:06	
47	NETT.LO	1996/10/30 19:16	
48	STRP.LO	1997/01/02 15:36	
49	VFYP.LO	1997/01/02 15:33	
50	VFYU.LO	1997/01/02 15:17	

SOFTWARE CONFIGURATION DISPLAY
ILLUSTRATION 4-21

Note

The configuration indicated on the software configuration display is different depending on the software version of console.

4-3-3 Utility Menu (Continued)

(H) MODEM SET UP

This displays and changes the current settings for the modem.

Type **8** and then press **Return** key when the Utility Menu is displayed. The Modem Set Up is displayed as shown in ILLUSTRATION 4-22.

```
Modem Set Up(1/1)
No Menu Name           Status
01 Telephone Jack Interface (RJ11/RJ41S/RJ145S)
02 Private Line Operation  Invalid
03 Modulation Mode at 300bps Bell 103

Enter Menu Name ?_
```

SOFTWARE CONFIGURATION DISPLAY

ILLUSTRATION 4-22

Procedure for Changing Each Settings

1. Input the item number you desire to change the settings. The choices for the selected item are displayed.
2. Type the appropriate number and press **Return**.

Note

This function is valid only when the USrobotics modem is selected by the option setting function of the service software. If the Motorola modem is selected, the message "This function is not available." is displayed on the CRT monitor screen.

4-3-3 Utility Menu (Continued)

(I) MEDIA INITIALIZE

This initialize the floppy disk.

Type **9** and then press **Return** key when the Utility Menu is displayed. The Media Initialize screen is displayed as shown in ILLUSTRATION 4-23.

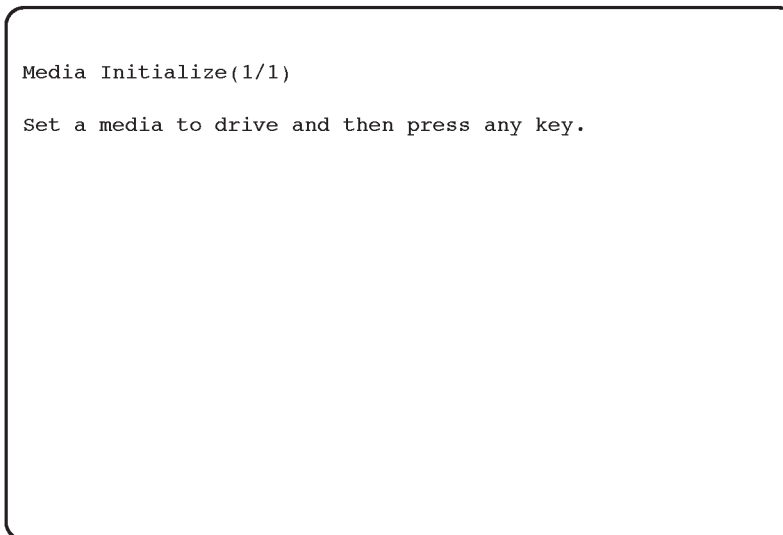

MEDIA INITIALIZATION
ILLUSTRATION 4-23

Procedure for Changing Each Settings

Insert an 128MB MO (Magneto Optical) disk (or 230MB disk for the console with software version 3.10 or later) and press the Return key. The system automatically starts initializing the MO disk. It takes approximately 15 minutes to complete initializing a disk.

Note

The 230MB MO disk is available on the console with software version 3.10 or later.

During the system is initializing MO disk, "Initializing" is displayed on the CRT monitor. After initializing, "Succeeded" or "Failed" is displayed on the CRT monitor. Then, the message "Press Y to continue, Control + R to quit" is displayed. Type **Y** and press **Return** to continue to use this function. Press and hold **Control**, and press **R** to quit this function.

4-3-3 Utility Menu (Continued)

(J) SYSTEM ID ENTRY/DISPLAY

This displays the current system ID number and sets the new one.

Type **10** and then press the **Return** key when the Utility Menu is displayed. The System ID Entry/Display menu is displayed as shown in ILLUSTRATION 4-24.

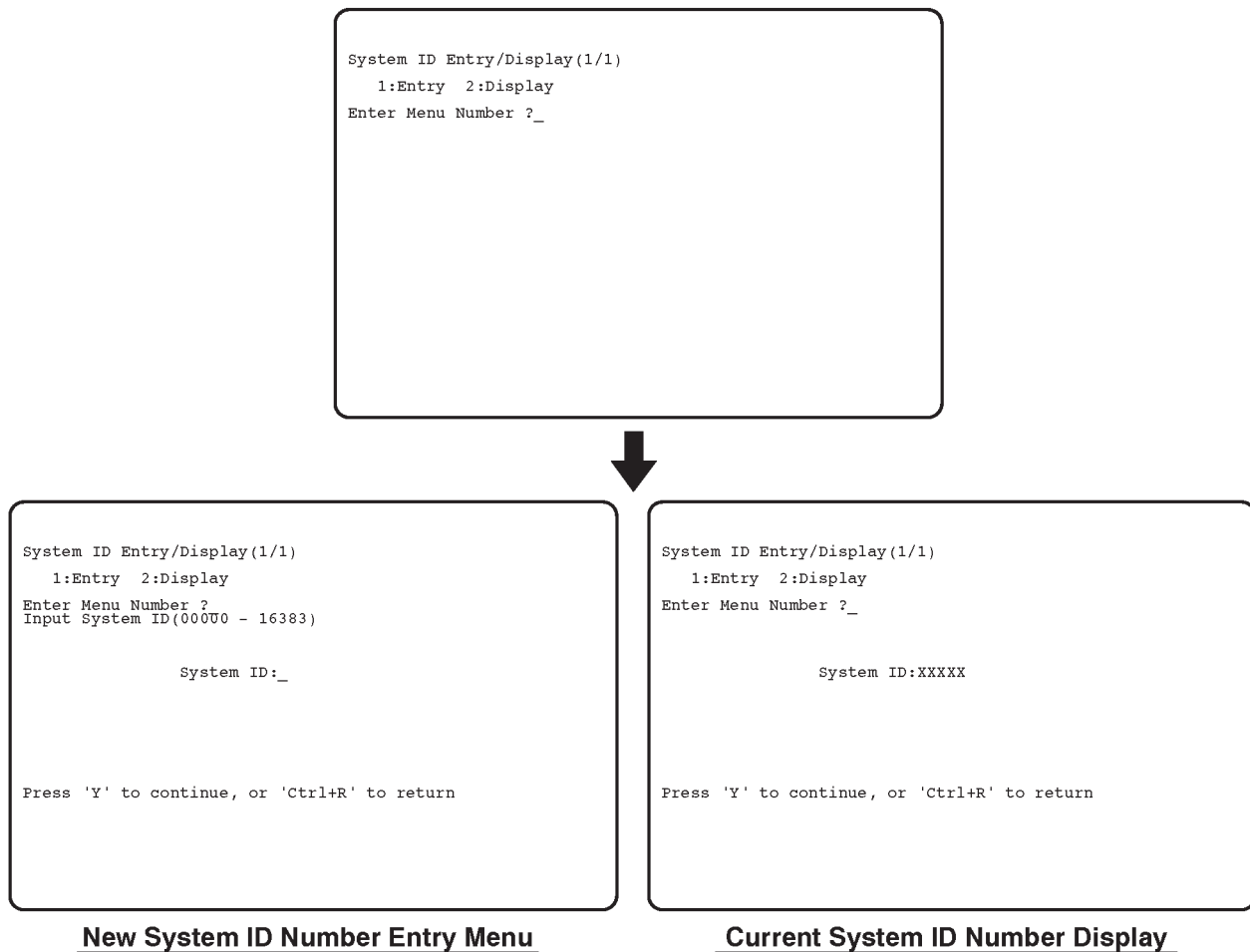

SYSTEM ID ENTRY/DISPLAY
ILLUSTRATION 4-24

4-3-3 Utility Menu (Continued)

(J) SYSTEM ID ENTRY/DISPLAY (Continued)

Procedure for Setting New System ID

1. Type **1** and then press the **Return** key. The system ID number entry menu is displayed on the CRT monitor screen as shown in ILLUSTRATION 4-24.
2. Type any 5-digit number within the limits of 00000 to 16383 and press the **Return** key. The new system ID number is set.

Procedure for Displaying Current System ID

1. Type **2** and then press the **Return** key. The current system ID number is displayed on the CRT monitor screen as shown in ILLUSTRATION 4-24.
2. Type **Y** and then press the **Return** key to continue this function. Press and hold the **Control** key and press **R** to exit this function.

4-3-3 Utility Menu (continued)**(K) MONITOR ADJUSTMENT**

This helps to adjust the settings of the Contrast and the Brightness on the CRT Monitor suitably.

Note

This function is available only for the console with the system software version 4.01 or later.

Type **11** and then press **Return** key when the Utility Menu is displayed. The Monitor Adjustment menu is displayed as shown in ILLUSTRATION 4-25.

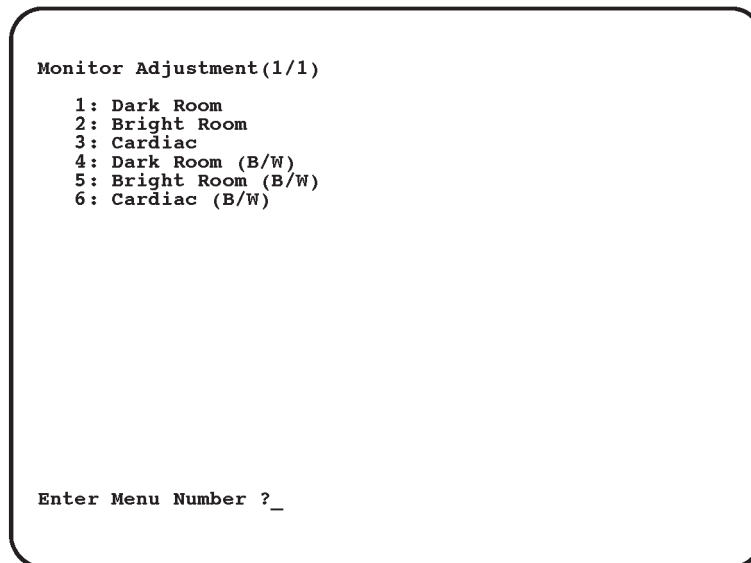

```
Monitor Adjustment(1/1)

1: Dark Room
2: Bright Room
3: Cardiac
4: Dark Room (B/W)
5: Bright Room (B/W)
6: Cardiac (B/W)

Enter Menu Number ?_
```

MONITOR ADJUSTMENT
ILLUSTRATION 4-25

4-3-3 Utility Menu (continued)

(K) MONITOR ADJUSTMENT (continued)

Procedure for Adjusting Monitor

1. Input the item number according to the brightness of Exam room.
The Gray Scale Bar for adjustment will be displayed on the CRT monitor screen as shown in ILLUSTRATION 4-26.

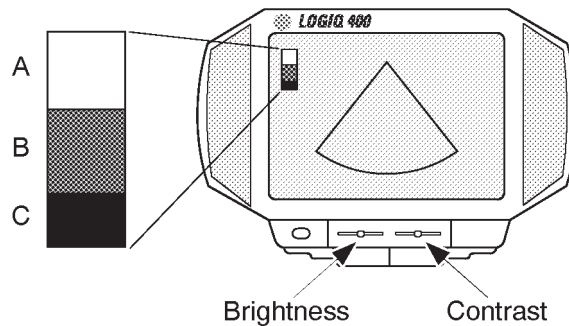

GRAY SCALE BAR
ILLUSTRATION 4-26

2. Open the front door at the lower center of the Monitor Assy by pushing the top center of the door.
3. Move **Contrast** and **Brightness** slide potentiometers rightwards to the maximum to increase both settings.
4. Decrease brightness by moving **Brightness** slide potentiometer leftwards by degrees until "**B**" in the gray scale bar is not visible.
5. Decrease contrast by moving **Contrast** slide potentiometer leftwards by degrees until "**A**" in the gray scale bar is not visible.
6. Move **Brightness** slide potentiometer rightwards to the maximum again.
7. Decrease brightness by moving **Brightness** slide potentiometer leftwards by degrees until "**C**" in the gray scale bar is not visible.

4-3-3 Utility Menu (continued)**(L) NETWORK ERROR LOG DISPLAY**

This displays and copies an error log file into a MO disk.

Note

This function is available only when the optional Storage/Print DICOM is enabled on the console with the system software version 3.40 or later.

Type **11** (**12** on the console with the software V4.01 or later) and then press **Return** key when the Utility Menu is displayed. The Network Error Log Display menu is displayed as shown in ILLUSTRATION 4-27.

```
Network Error Log Display (1/1)
001 1998/06/23 14:23
    Error in Binding the application. [104]

Do you copy this file ? (Y/N)_
```

NETWORK ERROR LOG DISPLAY
ILLUSTRATION 4-27

Procedure for Saving File

1. Type **Y** and then press **Return** key.
2. Insert a MO disk into the MOD drive and press any key.

During the time that the system is copying the error log file, "Copying now" is displayed on the CRT monitor screen.

This page is left blank intentionally.

4-4 POWER SUPPLY ADJUSTMENTS

This section provides power supply adjustment procedures for the LOGIQ™ 400. Adjustments should be only made when necessary. Power supply adjustments should be made in accordance with the schedule for periodic maintenance in Chapter 7 of this manual.

LOGIQ™ 400 has two types of Power Supply Unit, Power Supply Unit (2126982 for 115V and 2126981 for 220V) and Power Supply Unit 2 (2144481 for 115V and 2144480 for 220V). The Power Supply Unit is installed on the console which is shipped before May, 1996. The Power Supply Unit 2 is installed on the console which is shipped after June, 1996. The part number, components, and adjustment procedures are different between both types of Power Supply Unit. The section 4-4 provides the adjustment procedures for both types of Power Supply Unit.

Before beginning the power supply adjustments procedure, make sure the power outlet should provide the power line standards. Refer to Chapter 2, Installation.

Note

If the adjustment pot is over-turned clockwise, the power supply output is down to protect the circuits against the over-voltage. In that case, power the LOGIQ™ 400 OFF and turn the pot counterclockwise all the way. Then power it ON and try to adjust the power supply again.

There are five adjustable DC power supplies on the LV Unit, Low Voltage Unit of Power Supply Unit. The LV Unit is located at the bottom of the console as shown in ILLUSTRATION 4-30 on page 4-39.

There are seven adjustable DC power supplies on the LV2 Unit, Low Voltage 2 Unit of Power Supply Unit2. The LV2 Unit is located at the bottom of the console as shown in ILLUSTRATION 4-30 on page 4-39.

There are five adjustable DC power supplies on the LV3 Unit, Low Voltage 3 Unit of Power Supply Unit3. The LV3 Unit is located at the bottom of the console as shown in ILLUSTRATION 4-30 on page 4-39.

4-4-1 Power Supply Access

- 1. Unscrew four screws and remove the Side Cover Left as shown in the ILLUSTRATION 4-28.

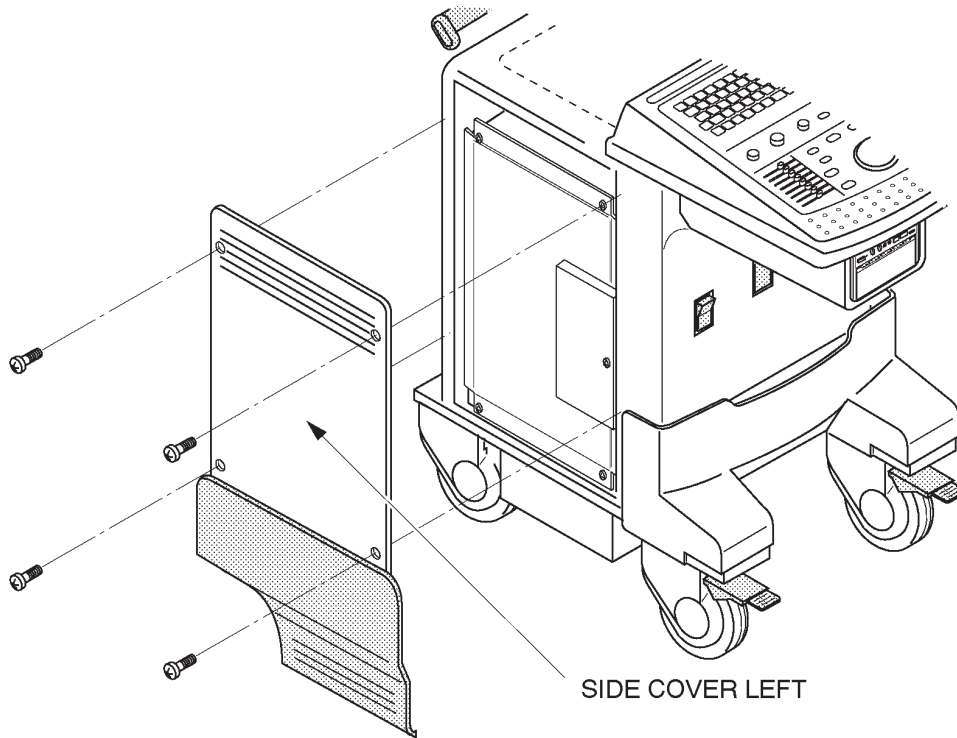

SIDE COVER LEFT REMOVAL
ILLUSTRATION 4-28

4-4-1 Power Supply Access (continued)

2. Unscrew four screws to remove the PS Cover Left. Refer to the ILLUSTRATION 4-29.

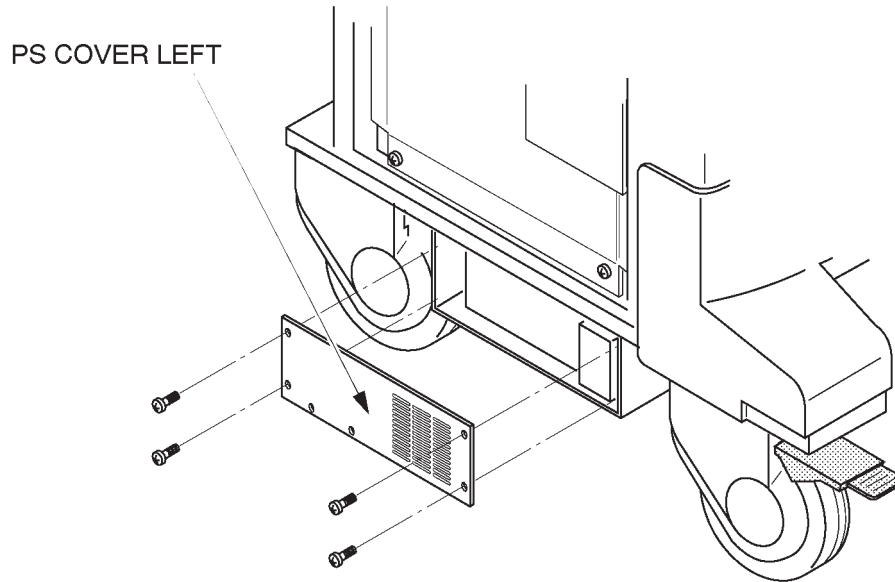

PS COVER LEFT REMOVAL
ILLUSTRATION 4-29

3. Unscrew two screws and pull the LV Unit out. Refer to the ILLUSTRATION 4-30.

Note

For the LV2 Unit and the LV3 Unit, the points for measuring and adjusting are located at the front of the unit. It is not necessary to pull the LV unit out of the Power Supply Unit2 and Power Supply Unit3.

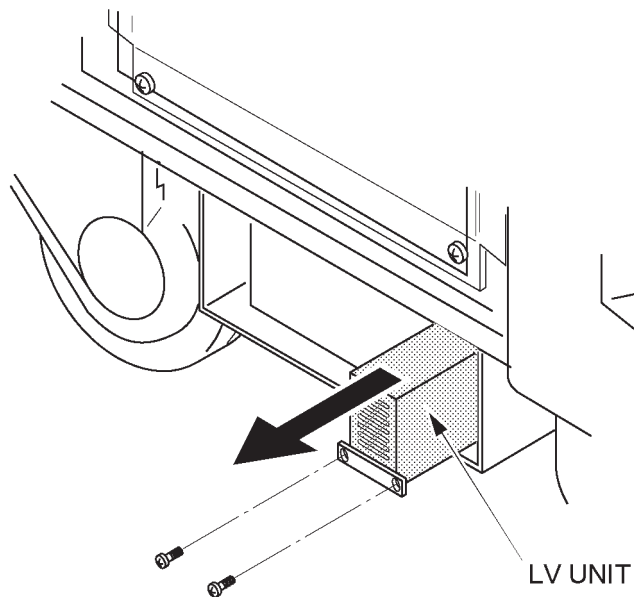

LV UNIT
ILLUSTRATION 4-30

4-4-2 Power Supply Adjustment Procedure

1. Power LOGIQ™ 400 ON. Wait for about 30 seconds to warm up the console.
2. For each of the power supplies which are located on the LV Unit, connect a DVM to the appropriate place shown in TABLE 4-1 for the Power Supply Unit, TABLE 4-3 on page 4-42 for the Power Supply Unit 2 or TABLE 4-5 on page 4-44 for the Power Supply Unit 3.
3. Verify that the voltages are as shown in TABLE 4-2 for the Power Supply Unit, TABLE 4-4 on page 4-42 for the Power Supply Unit 2 or TABLE 4-6 on page 4-44 for the Power Supply Unit 3, respectively.

TABLE 4-1
POWER SUPPLY MEASUREMENT LOCATION

POWER SUPPLY	MEASURE AT	RETURN AT
+5V for Digital	+5V Terminal on Power Supply See ILLUSTRATION 4-31	GND Terminal on Power Supply See ILLUSTRATION 4-31
+5V for Analog	+5V Terminal on Power Supply See ILLUSTRATION 4-31	GND Terminal on Power Supply See ILLUSTRATION 4-31
-5V	-5V Terminal on Power Supply See ILLUSTRATION 4-31	GND Terminal on Power Supply See ILLUSTRATION 4-31
+12V	+12V Terminal on Power Supply See ILLUSTRATION 4-31	GND Terminal on Power Supply See ILLUSTRATION 4-31
-12V	-12V Terminal on Power Supply See ILLUSTRATION 4-31	GND Terminal on Power Supply See ILLUSTRATION 4-31

TABLE 4-2
POWER SUPPLY MEASUREMENT TOLERANCES

POWER SUPPLY	MIN.	MAX
+5V for Digital	+5.10 V	+5.20 V
+5V for Analog	+5.10 V	+5.20 V
-5V	-5.10 V	-5.20 V
+12V	+12.10 V	+12.20 V
-12V	-12.10 V	-12.20 V

4-4-2 Power Supply Adjustment Procedure (continued)

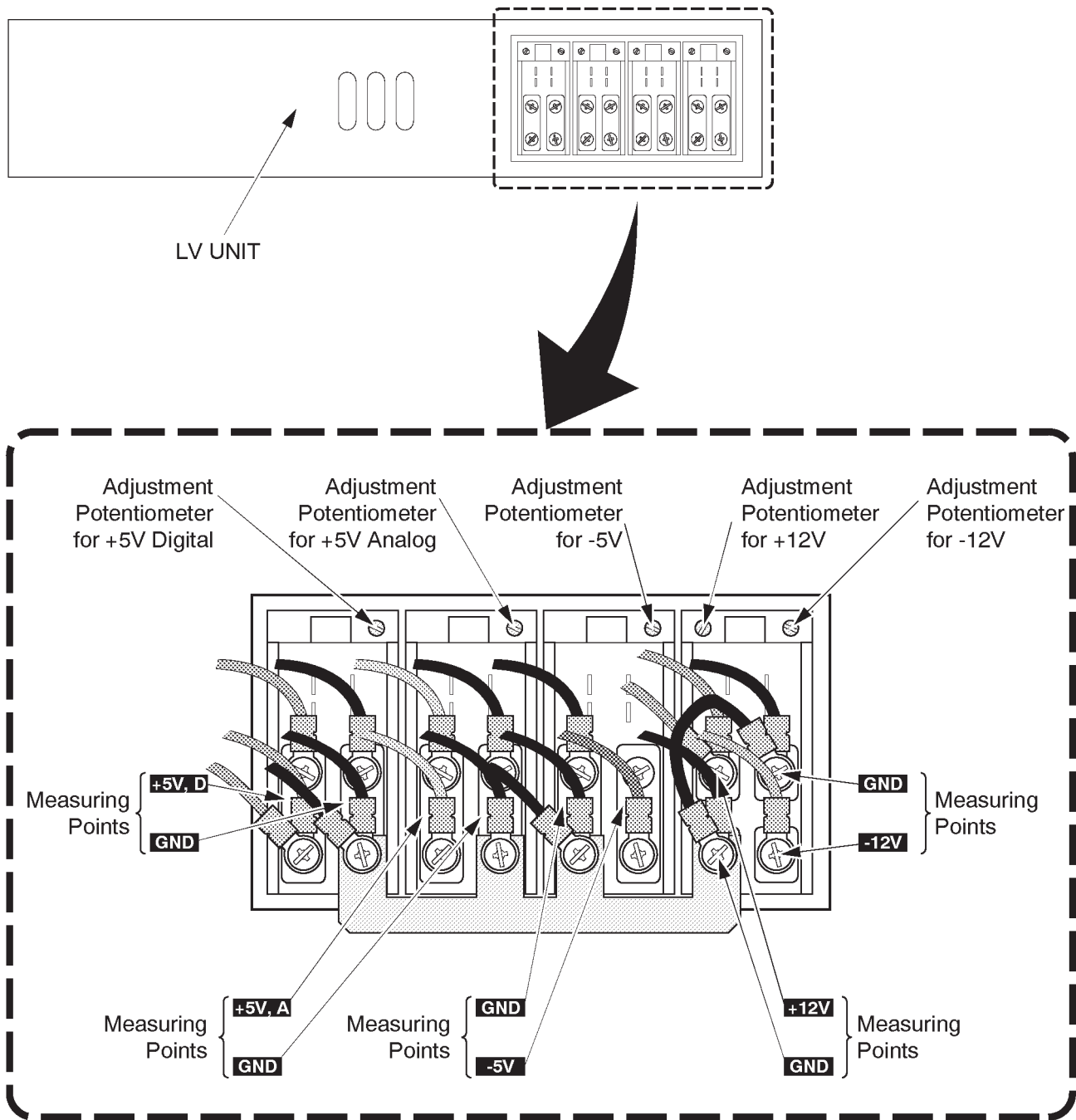

POWER SUPPLIES ON LV UNIT
ILLUSTRATION 4-31

■ 4-4-2 Power Supply Adjustment Procedure (continued)

TABLE 4-3
POWER SUPPLY 2 MEASUREMENT LOCATION

POWER SUPPLY	MEASURE AT	RETURN AT
+5V for Digital	+5V Terminal on Power Supply See ILLUSTRATION 4-32	GND Terminal on Power Supply See ILLUSTRATION 4-32
+5V for Analog	+5V Terminal on Power Supply See ILLUSTRATION 4-32	GND Terminal on Power Supply See ILLUSTRATION 4-32
+12V	+12V Terminal on Power Supply See ILLUSTRATION 4-32	GND Terminal on Power Supply See ILLUSTRATION 4-32
-5V	-5V Terminal on Power Supply See ILLUSTRATION 4-32	GND Terminal on Power Supply See ILLUSTRATION 4-32
+15V	+15V Terminal on Power Supply See ILLUSTRATION 4-32	GND Terminal on Power Supply See ILLUSTRATION 4-32

TABLE 4-4
POWER SUPPLY 2 MEASUREMENT TOLERANCES

POWER SUPPLY	MIN.	MAX
+5V for Digital	+5.25 V	+5.35 V
+5V for Analog	+5.35 V	+5.45 V
+12V	+12.10 V	+12.20 V
-5V	-5.10 V	-5.20 V
+15V	+15.40 V	+15.50 V

4-4-2 Power Supply Adjustment Procedure (continued)



The potentiometers ① and ② indicated in ILLUSTRATION 4-32 are used only for the supplier adjustment. Do not touch and rotate these potentiometers.

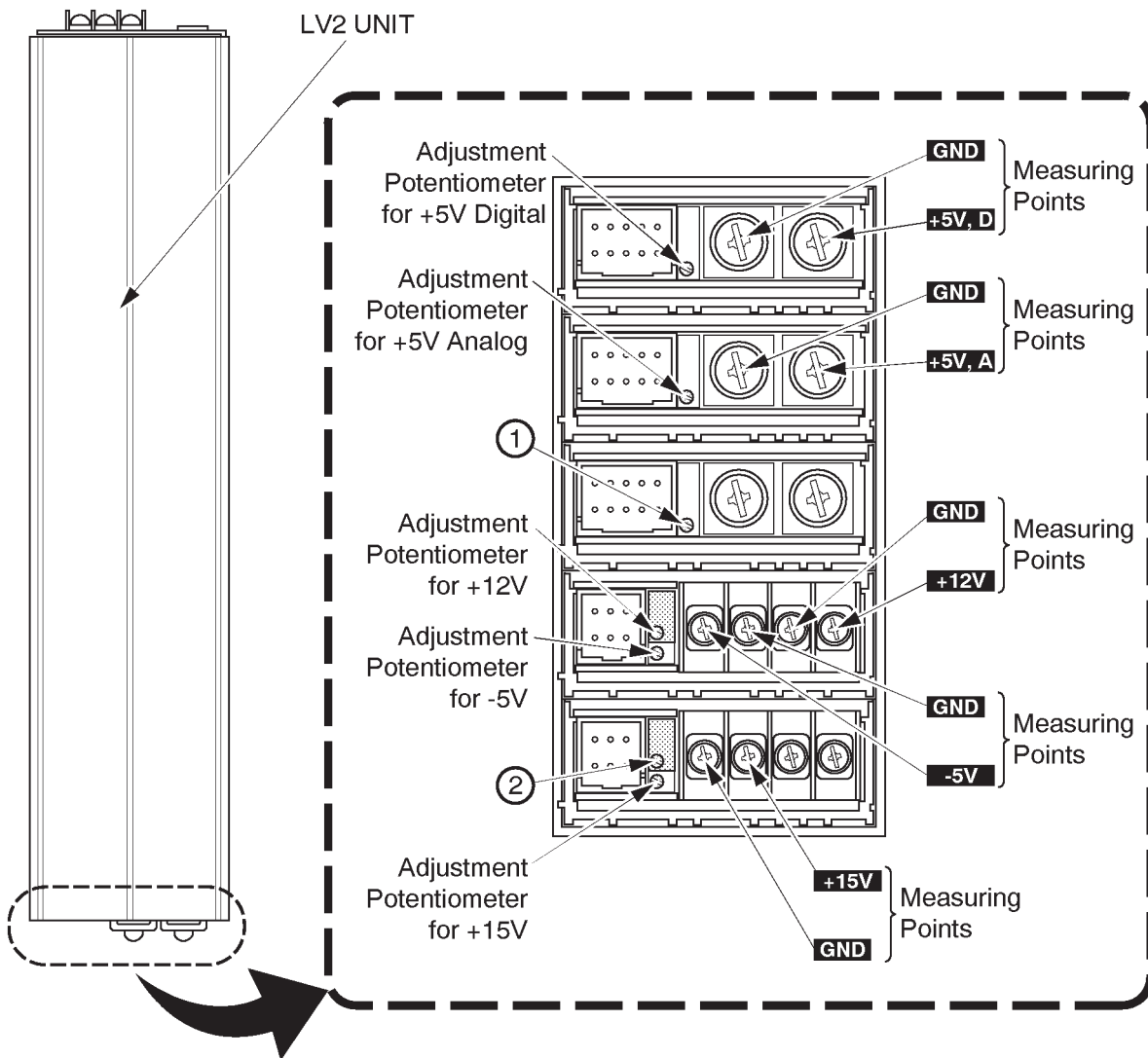

POWER SUPPLIES ON LV2 UNIT
ILLUSTRATION 4-32

Note

Use a non-conductive trim-pot to adjust the power supply.

4-4-2 Power Supply Adjustment Procedure (continued)

TABLE 4-5
POWER SUPPLY 3 MEASUREMENT LOCATION

POWER SUPPLY	MEASURE AT	RETURN AT
+5V for Digital	+5VD Terminal on Power Supply See ILLUSTRATION 4-33	GND Terminal on Power Supply See ILLUSTRATION 4-33
+5V for Analog	+5VA Terminal on Power Supply See ILLUSTRATION 4-33	GND Terminal on Power Supply See ILLUSTRATION 4-33
+12V	+12V Terminal on Power Supply See ILLUSTRATION 4-33	GND Terminal on Power Supply See ILLUSTRATION 4-33
-5V	-5V Terminal on Power Supply See ILLUSTRATION 4-33	GND Terminal on Power Supply See ILLUSTRATION 4-33
+15V	+15V Terminal on Power Supply See ILLUSTRATION 4-33	GND Terminal on Power Supply See ILLUSTRATION 4-33

TABLE 4-6
POWER SUPPLY 3 MEASUREMENT TOLERANCES

POWER SUPPLY	MIN.	MAX.
+5V for Digital	+5.25V	+5.35V
+5V for Analog	+5.35V	+5.45V
+12V	+12.10V	+12.20V
-5V	-5.10V	-5.20V
+15V	+15.40V	+15.50V

4-4-2 Power Supply Adjustment Procedure (continued)

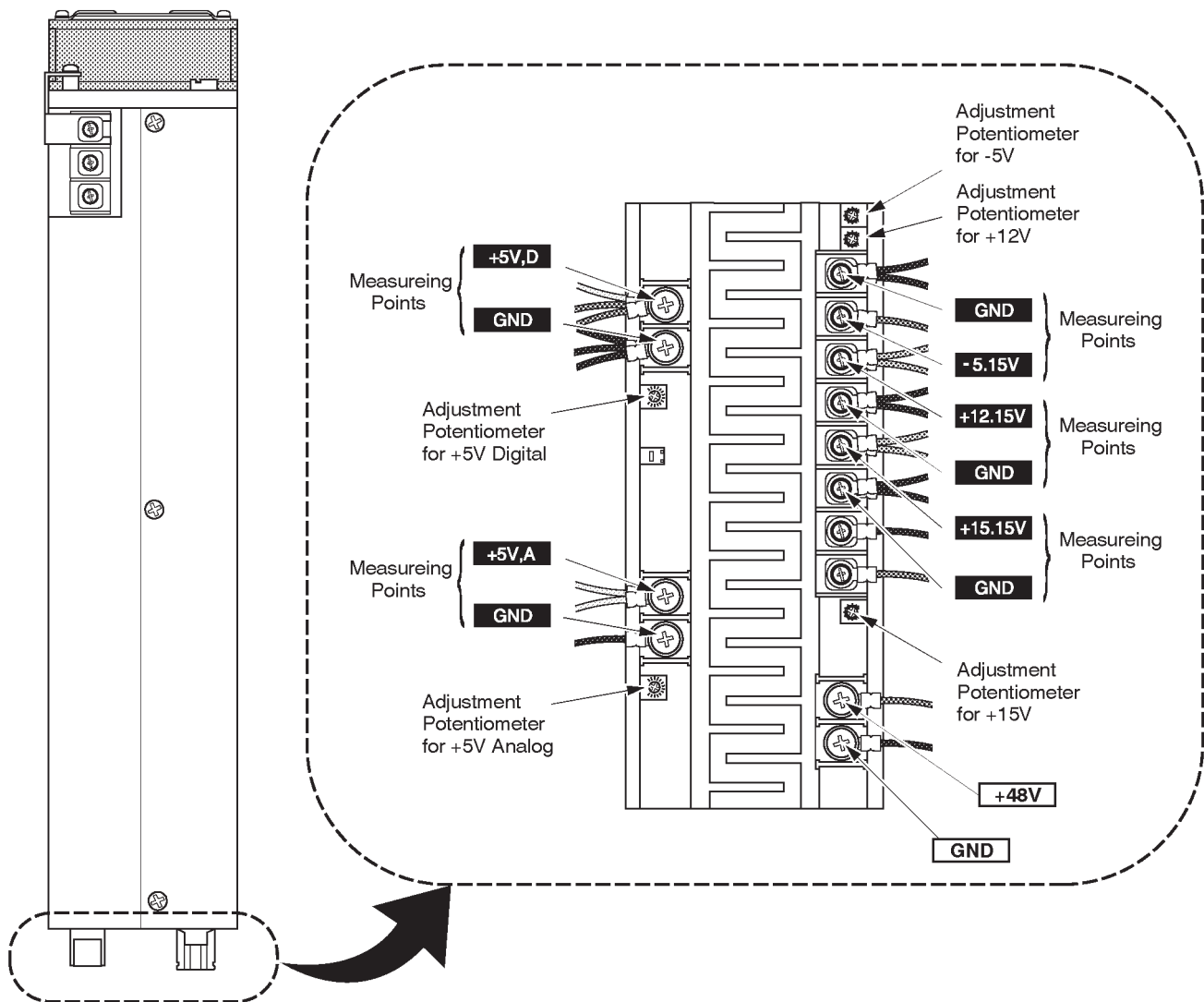

POWER SUPPLIES ON LV3 UNIT
ILLUSTRATION 4-33

Note

Check the +48V output as necessary. Refer to ILLUSTRATION 4-33 for the measuring points.
Tolerance: +48V ±2.4V

Note

Use a non-conductive trim-pot to adjust the power supply.

5-1 INTRODUCTION

LOGIQ™ 400 is a compact ultrasound scanner supporting a wide range of probes. This gives the system added benefits to meet diverse applications.

5-2 LOGIQ™ 400 SYSTEM

The LOGIQ™ 400 has a 64 channel beam former that digitizes the RF signal. It uses analog and digital delay to focus the beam. The analog delay is short and fixed. The digital delay is used for long delay and dynamic focus. This system also features many advanced image processing controls.

User surveys and the latest technology were used to increase console ease-of-use. Digital circuitry enables more reliable and precise operation.

System Features

The key design goals of this system are:

- High Image Quality
- Increased User Productivity
- Multiple Clinical Applications
- Planned Upgradeability
- High Mobility

Types of Applications

The system supports many clinical uses. Scan and display parameters may be user selected to default to desired values for each application. The system presets many parameters to clinically determined, optimal values.

- Radiology
- Cardiology
- OB/GYN, and
- Vascular

See Illustration 5-1, the LOGIQ™ 400 system can be divided into an analog signal processing section, a digital signal processing section, and the microprocessor driven system control section, which controls the system based on operator commands and system status information.

5-3 BLOCK DIAGRAM

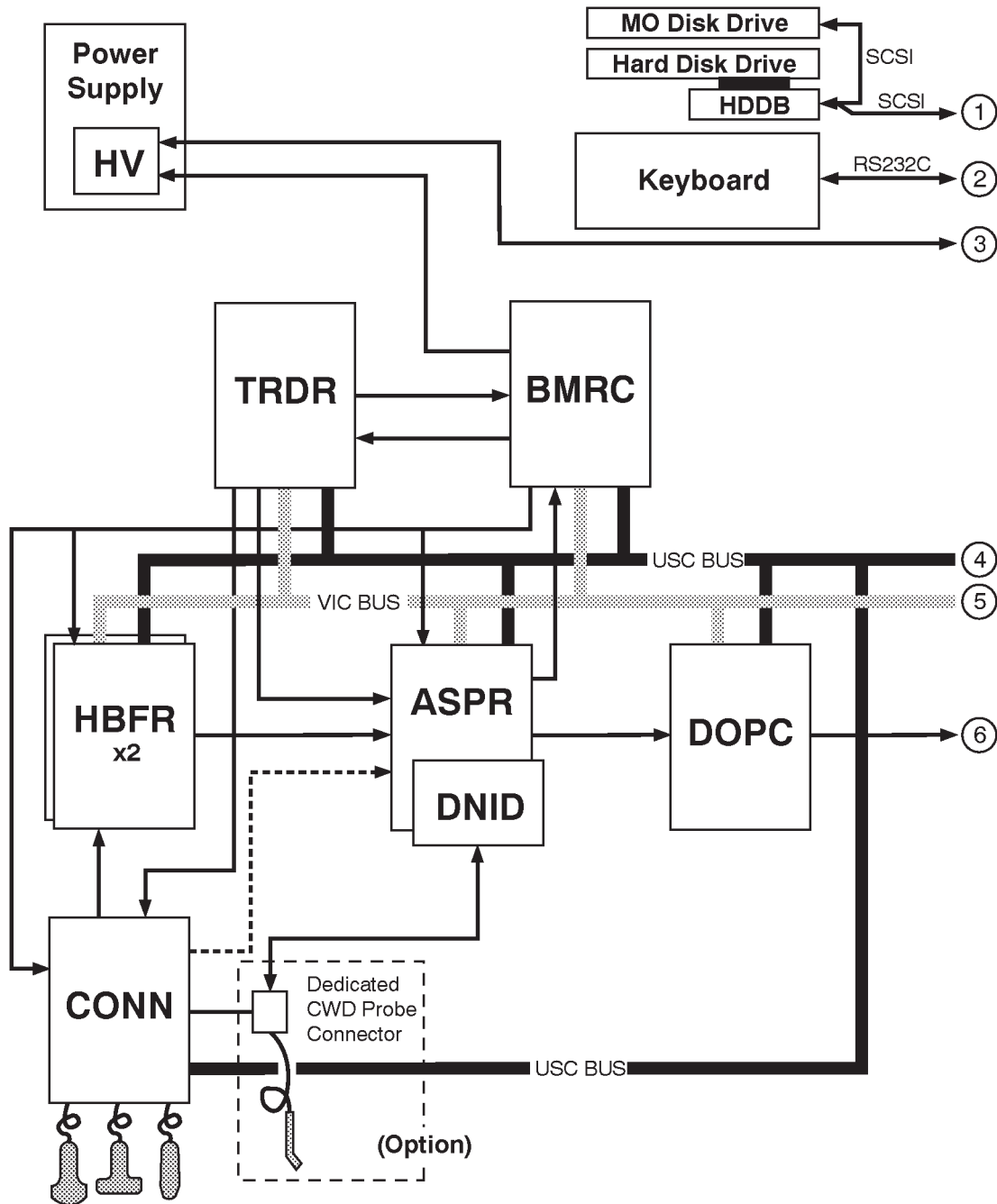

LOGIQ™ 400 SYSTEM BLOCK DIAGRAM (For Color Monitor Model and B/W Model with S/W V4.01 or Later)
ILLUSTRATION 5-1 (a)

Note

The DOPC Assy is supplied to the B/W console with the software V4.01 or later with the optional Doppler Upgrade.

5-3 BLOCK DIAGRAM (continued)

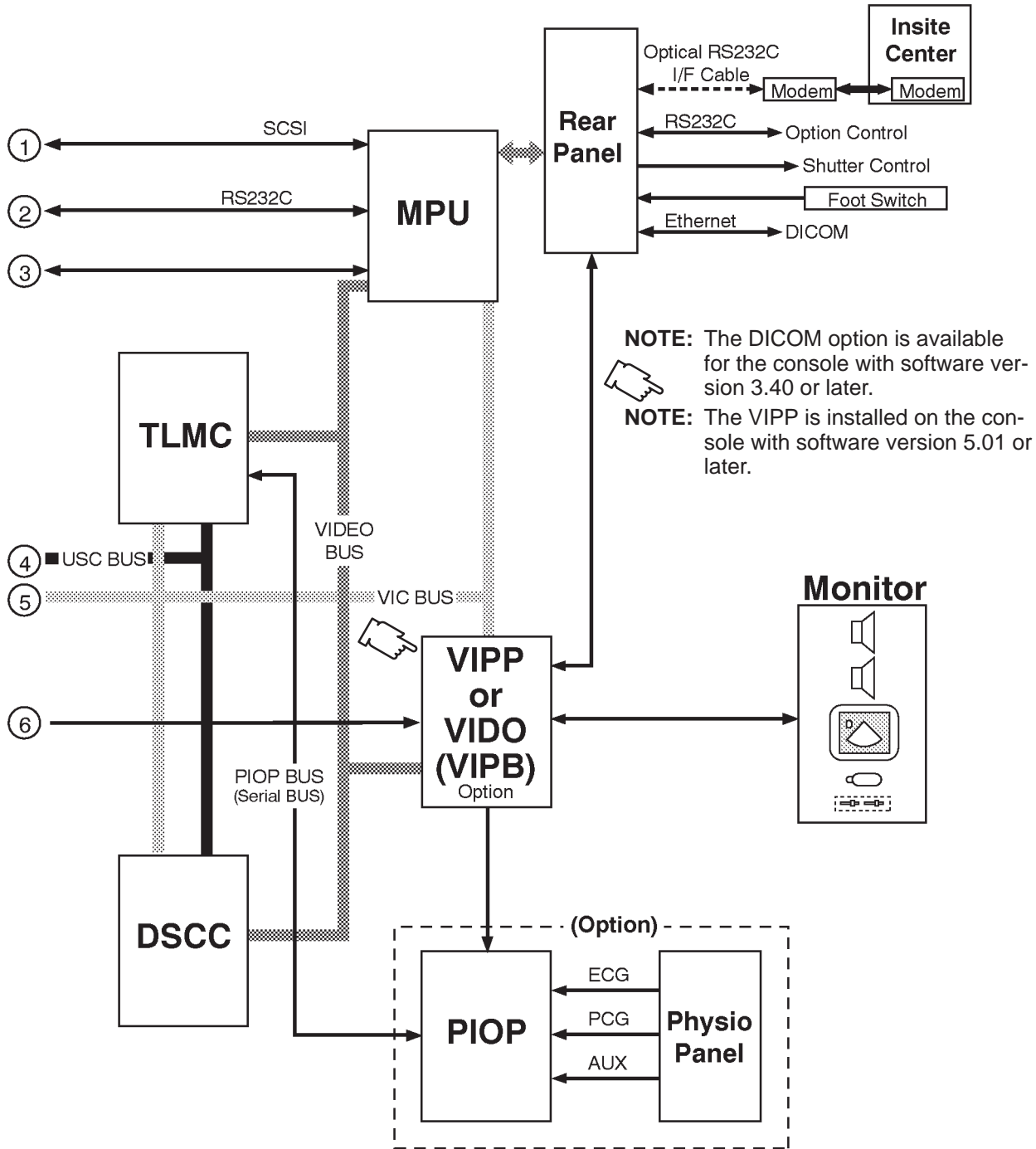

LOGIQ™ 400 SYSTEM BLOCK DIAGRAM (For Color Monitor Model and B/W Model with S/W V4.01 or Later)
ILLUSTRATION 5-1 (b)

5-3 BLOCK DIAGRAM (continued)

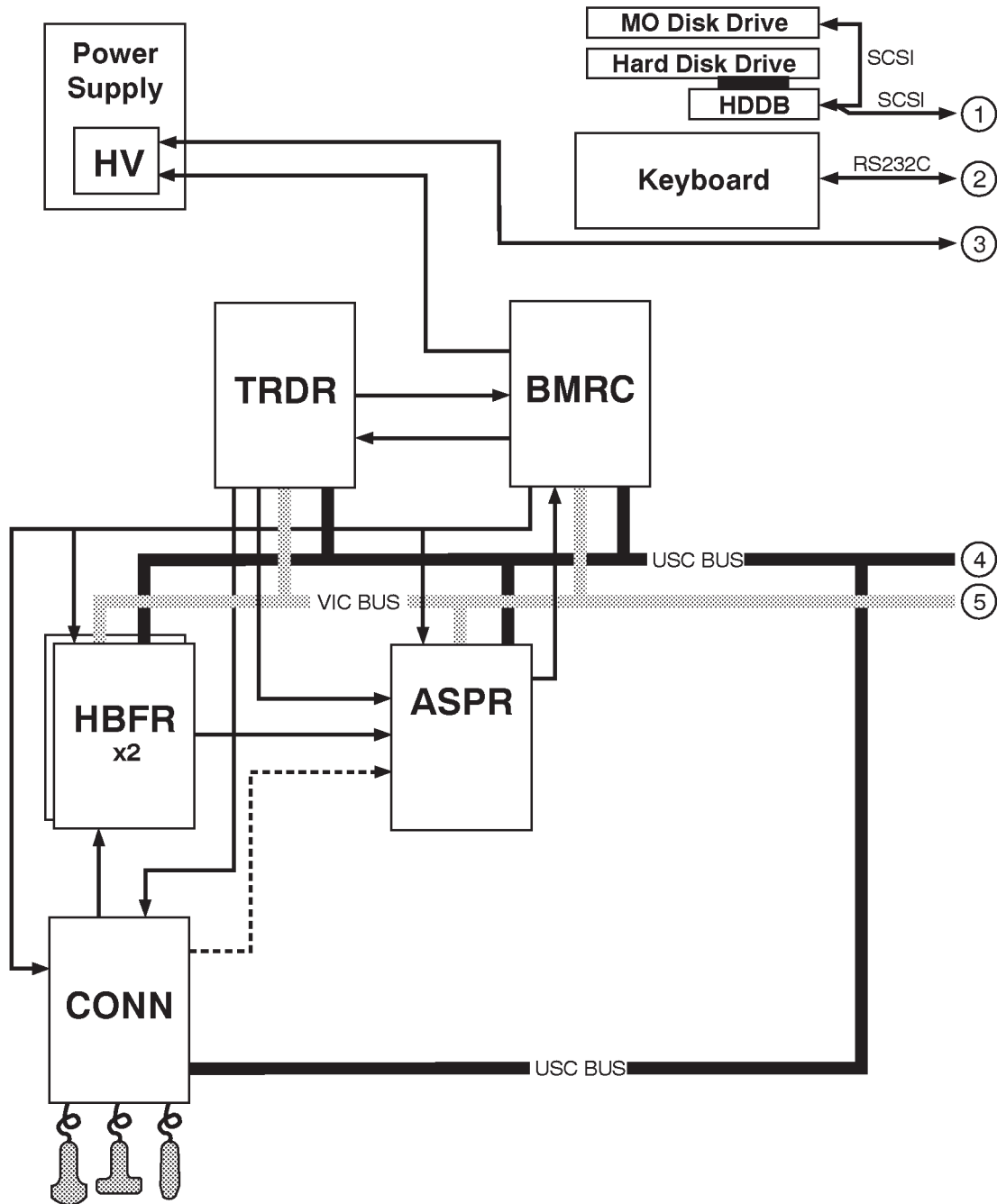

LOGIQ™ 400 SYSTEM BLOCK DIAGRAM (For B/W Monitor Model with S/W V3.40 or Earlier)
ILLUSTRATION 5-2 (a)

Note

The B/W console with the software version 4.01 or later has the same board configurations with the CFM console except to the DOPC Assy.

5-3 BLOCK DIAGRAM (continued)

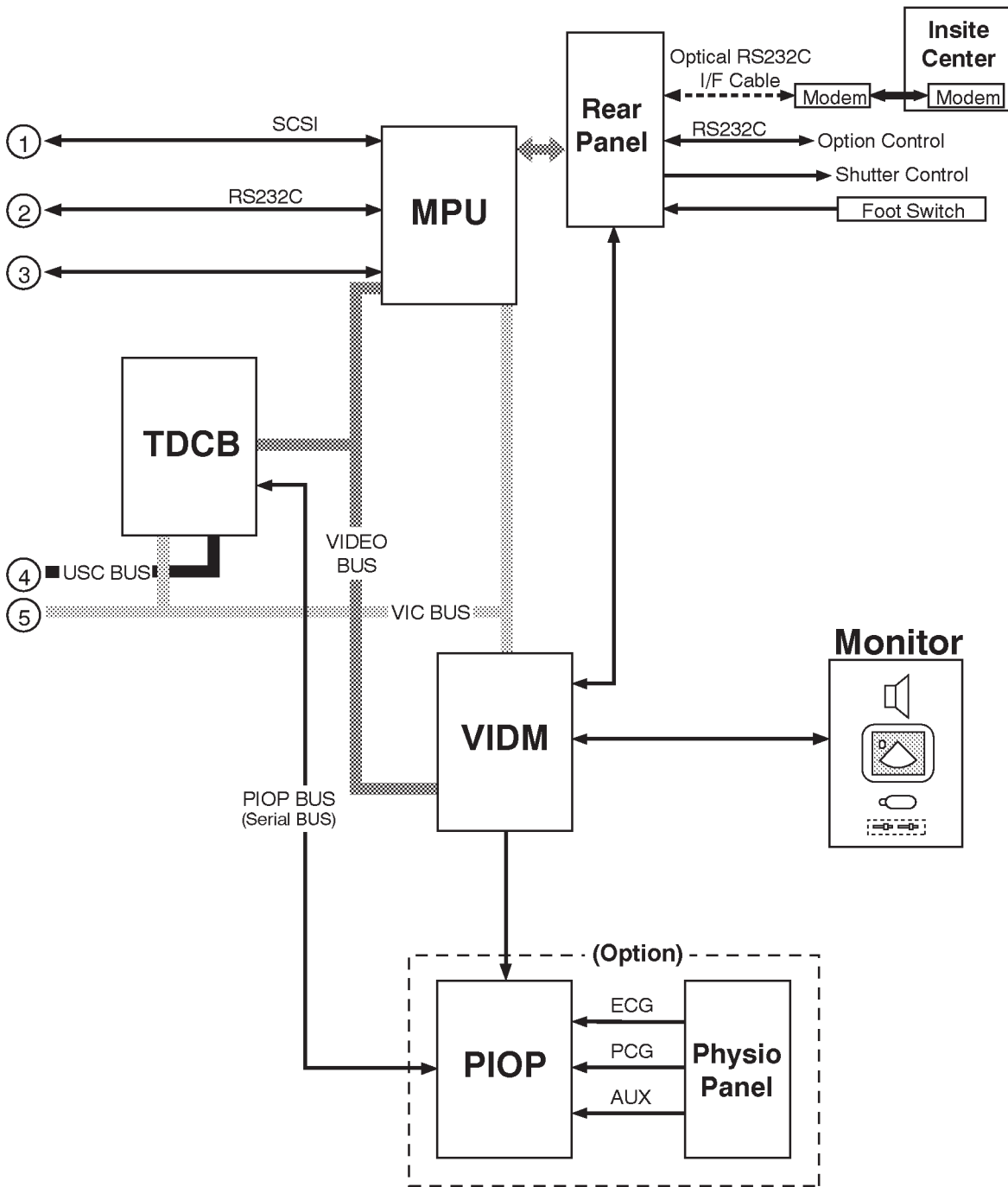

LOGIQ™ 400 SYSTEM BLOCK DIAGRAM (For B/W Monitor Model with S/W V3.40 or Earlier)
ILLUSTRATION 5-2 (b)

5-4 WIRING DIAGRAM

NOTE: The CB46 and CB45N are not installed in the console with the new 3.5-inch HDD (Quantum™ Fireball™ 1280S and Quantum™ Fireball™ EL) because the HDD LED Assy is not supplied.

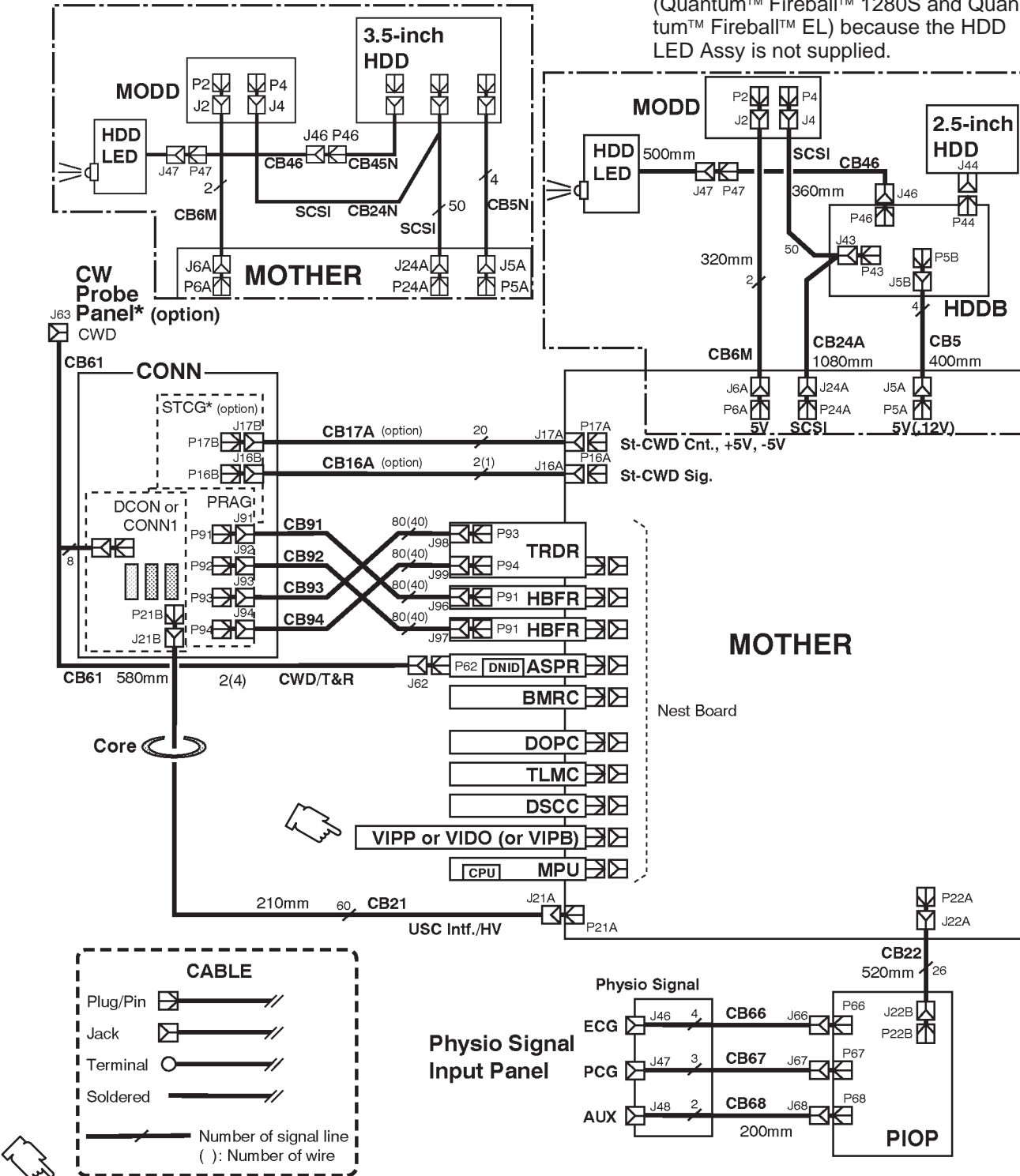

LOGIQ™ 400 SYSTEM WIRING DIAGRAM (For Color Monitor Model and B/W Model with S/W V4.01 or Later)

ILLUSTRATION 5-3 (a)

5-4 WIRING DIAGRAM (continued)

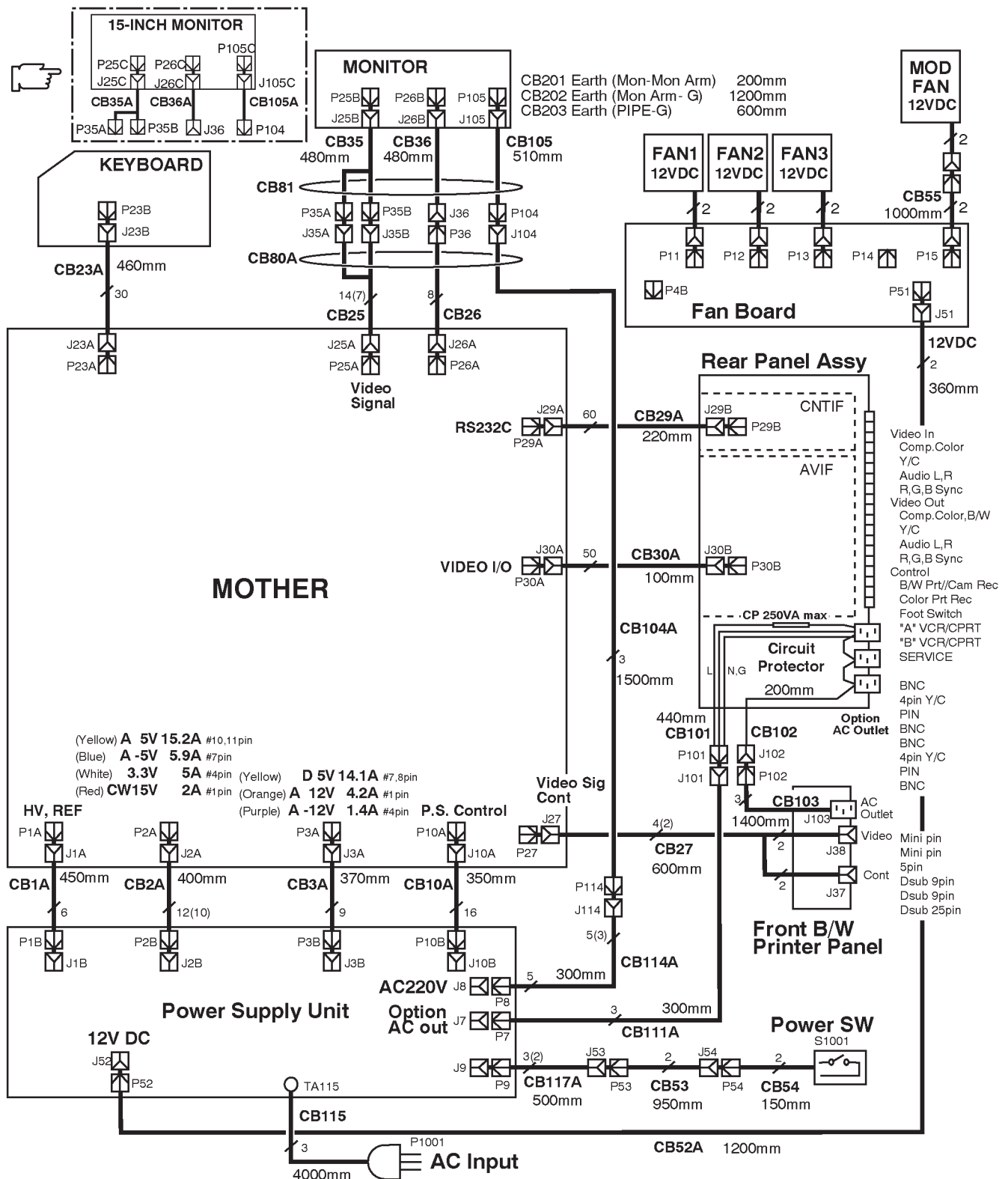

LOGIQ™ 400 SYSTEM WIRING DIAGRAM (For Color Monitor Model and B/W Model with S/W V4.01 or Later)
 ILLUSTRATION 5-3 (b)

5-4 WIRING DIAGRAM (continued)

NOTE: The CB46 and CB45N are not installed in the console with the new 3.5-inch HDD (Quantum™ Fireball™ 1280S and Quantum™ Fireball™ EL) because the HDD LED Assy is not supplied.

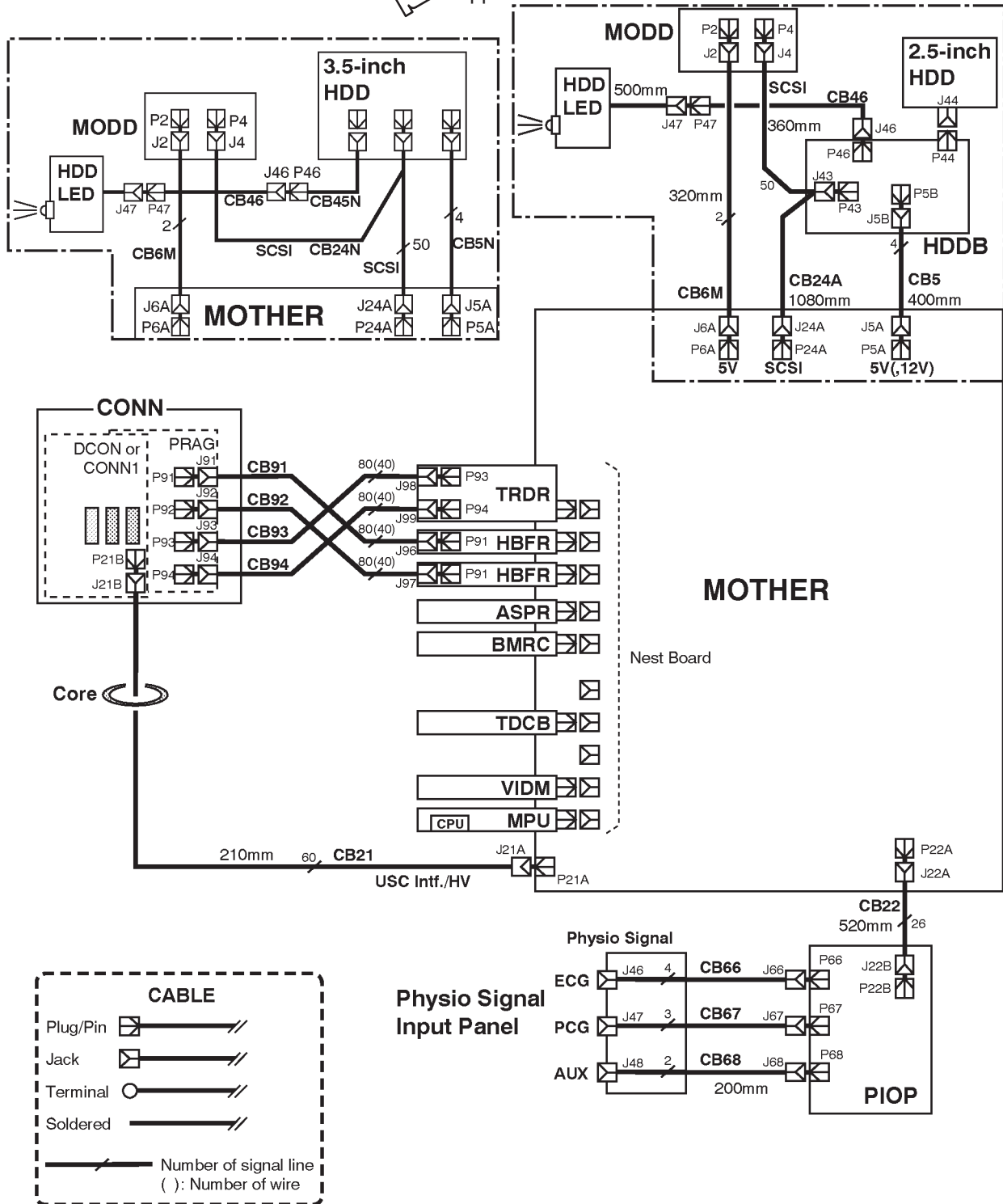

LOGIQ™ 400 SYSTEM WIRING DIAGRAM (For B/W Monitor Model with S/W V3.40 or Earlier)

ILLUSTRATION 5-4 (a)

5-5 POWER SUPPLY BLOCK DIAGRAM

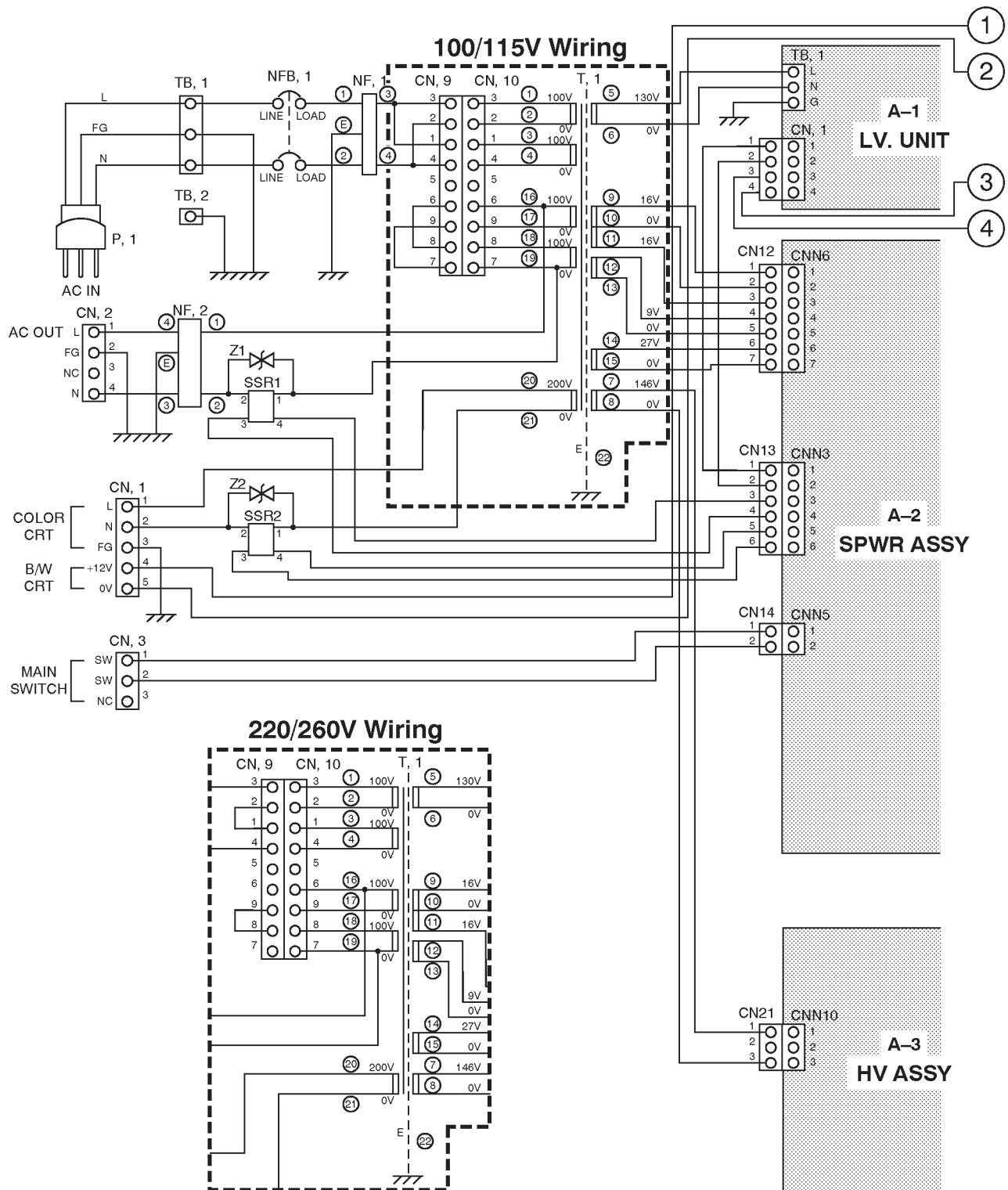

LOGIQ™ 400 SYSTEM POWER SUPPLY BLOCK DIAGRAM

ILLUSTRATION 5-5 (a)

5-5 POWER SUPPLY BLOCK DIAGRAM (Continued)

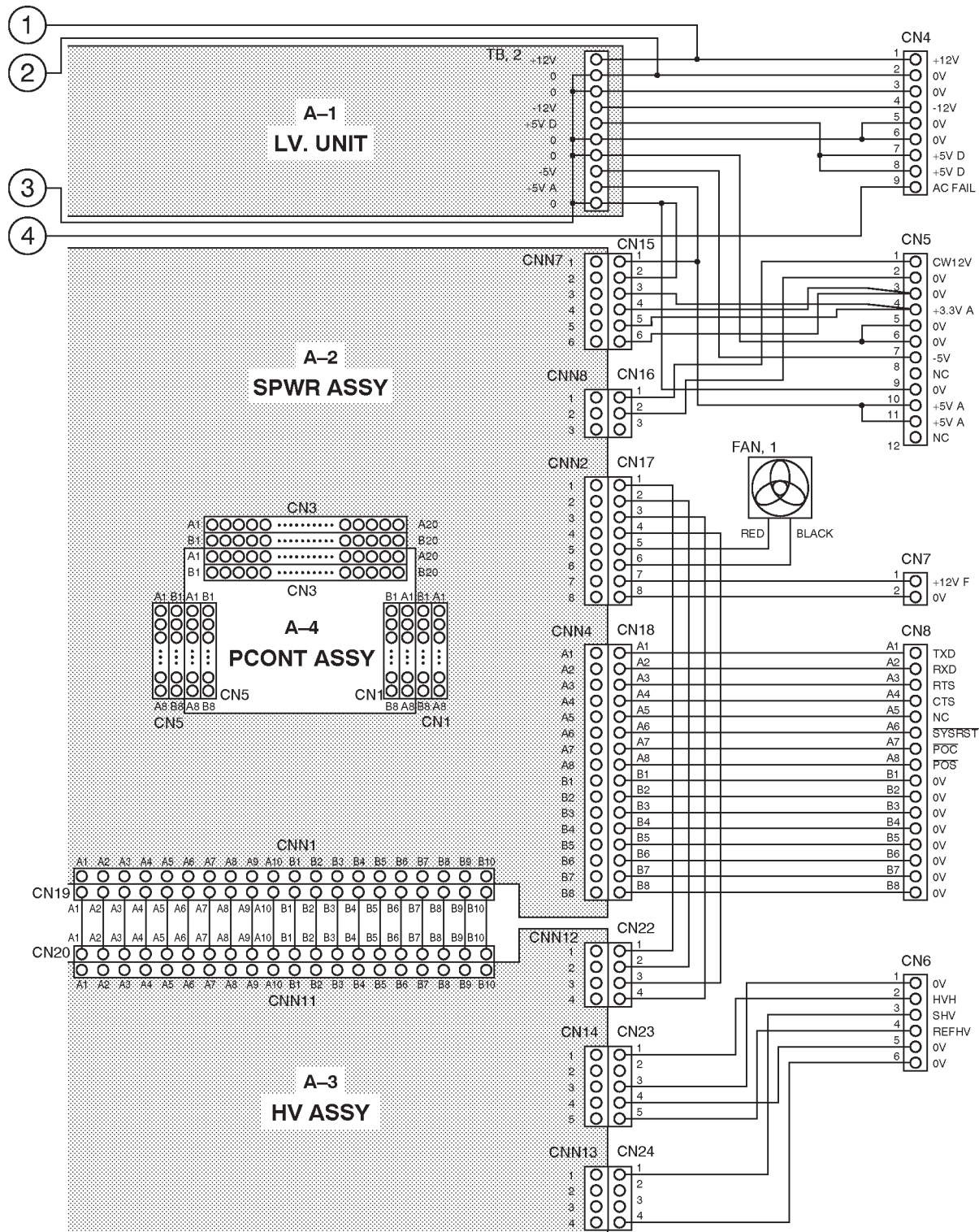

LOGIQ™ 400 SYSTEM POWER SUPPLY BLOCK DIAGRAM

ILLUSTRATION 5-5 (b)

5-6 POWER SUPPLY2 BLOCK DIAGRAM

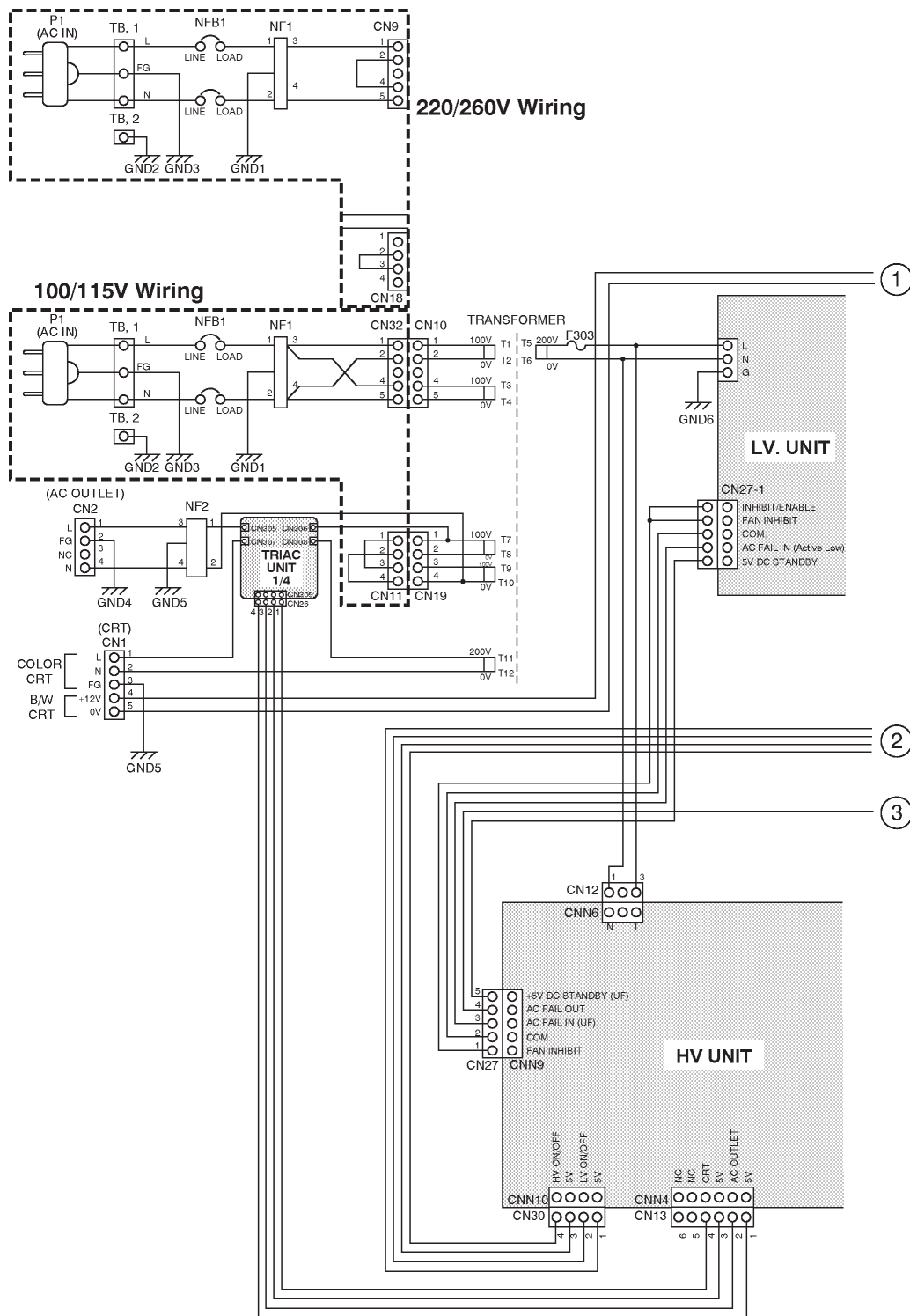

LOGIQ™ 400 SYSTEM POWER SUPPLY2 BLOCK DIAGRAM
ILLUSTRATION 5-6 (a)

5-6 POWER SUPPLY2 BLOCK DIAGRAM (Continued)

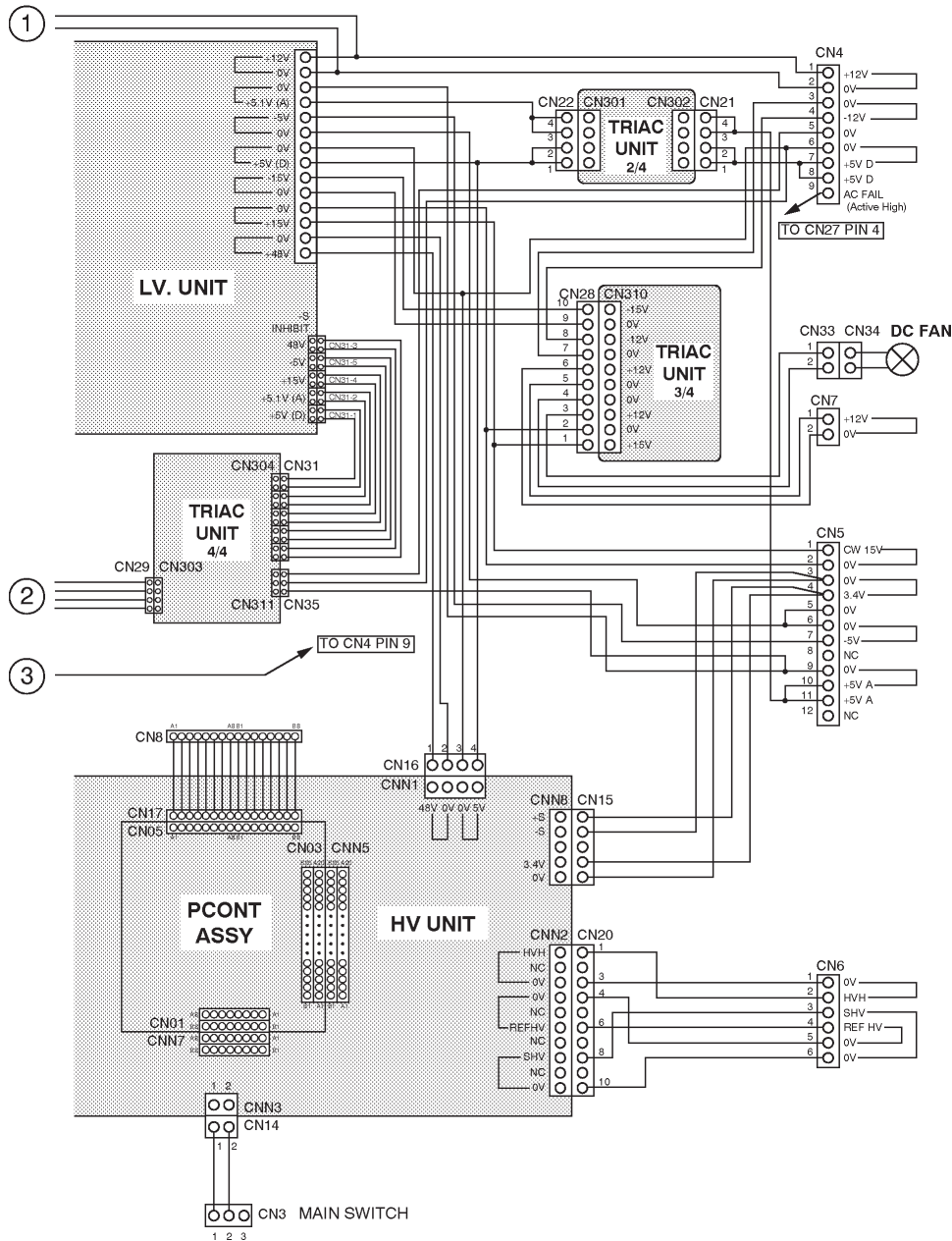

LOGIQ™ 400 SYSTEM POWER SUPPLY2 BLOCK DIAGRAM
ILLUSTRATION 5-6 (b)

5-7 POWER SUPPLY3 BLOCK DIAGRAM

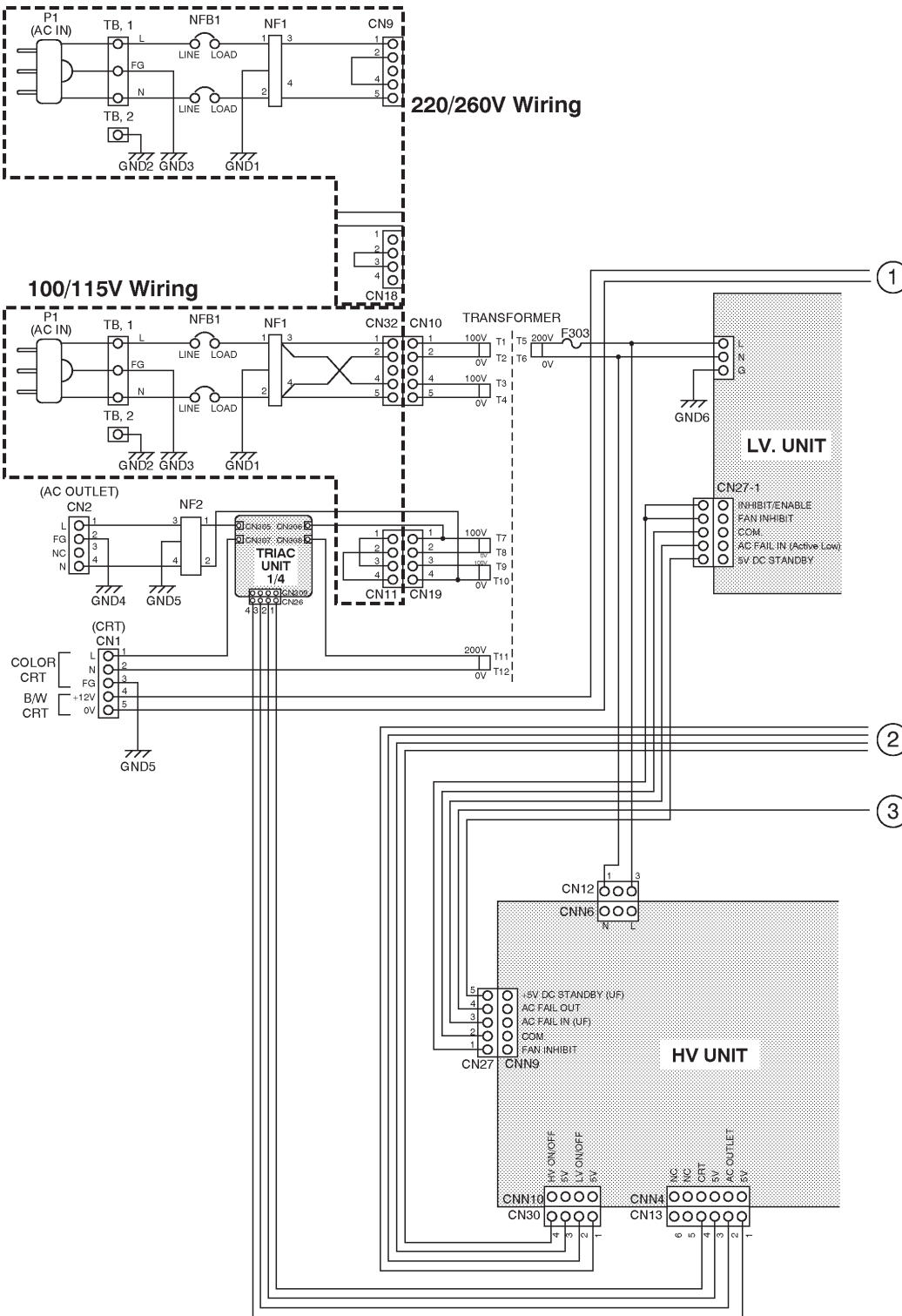

LOGIQ™ 400 SYSTEM POWER SUPPLY3 BLOCK DIAGRAM
ILLUSTRATION 5-7 (a)

5-7 POWER SUPPLY3 BLOCK DIAGRAM (continued)

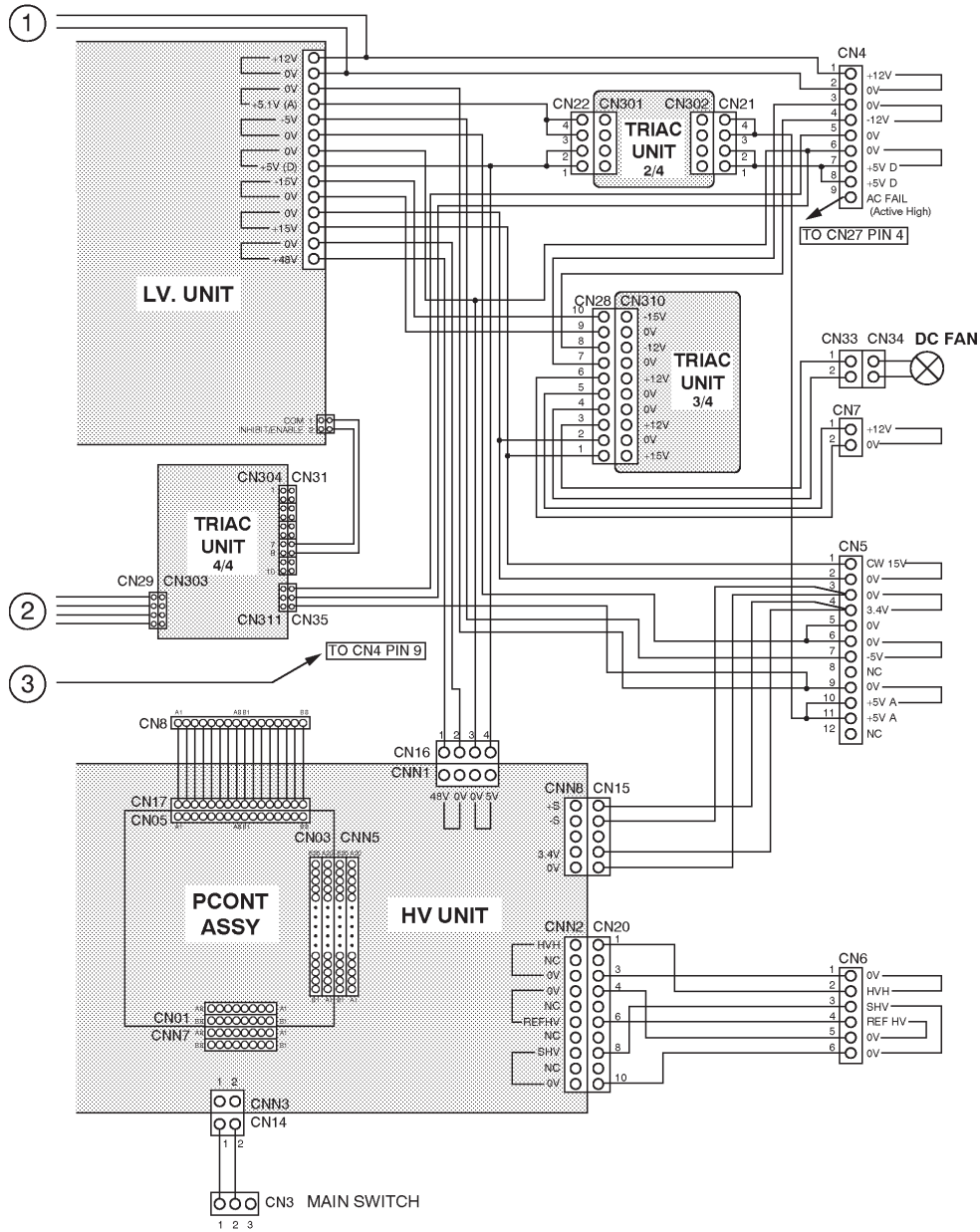

LOGIQ™ 400 SYSTEM POWER SUPPLY3 BLOCK DIAGRAM
ILLUSTRATION 5-7 (b)

5-8 CIRCUIT BOARD DESCRIPTION

The following table lists circuit boards, their respective card cage slot assignments on the mother board and the locations of other circuit boards.

TABLE 5-1
CIRCUIT BOARD DESCRIPTION

CARD CAGE SLOT	NAME	DESCRIPTIONS	CONSOLE TYPE		
			COLOR MONITOR WITH VTR PLAYBACK	COLOR MONITOR WITHOUT VTR PLAYBACK	BLACK & WHITE MONITOR
A1	TRDR ASSY	Transmit Driver Assembly	1	1	1
A2	HBFR ASSY	Hybrid Beam Former for Reception Assembly	1	1	1
A3	HBFR ASSY	Hybrid Beam Former for Reception Assembly	1	1	1
A4	ASPR ASSY	Analog Signal Processor Assembly	1	1	1
A7	BMRC ASSY	B/M Mode Processor and Real Time Controller Assembly	1	1	1
A8	DOPC ASSY	Doppler and CFM Middle Processor Assembly	1	1	
A9	TLMC ASSY	Time Line Memory Processor and Cine Assembly	1	1	
	TDCB ASSY	Time Line Memory Processor, Cine, and Digital Scan Converter for B/W Assembly			1
A10	DSCC ASSY	Digital Scan Converter CFM Assembly	1	1	
A11	VIPB ASSY	Video Output Processor with VTR Playback Memory Assembly	1		
	VIPPASSY	Video Assy with Interlace Progressive Scan Converter and VCR Playback	1		
	VIDM ASSY	Video Output Processor for B/W Assembly			1
A11	VIDM ASSY	Video Output Processor for B/W Assembly			1
A12	MPU ASSY	Master Controller and CPU Extend Board Assembly	1	1	1

CARD CAGE SLOT	NAME	DESCRIPTIONS	CONSOLE TYPE	
			COLOR MONITOR	BLACK & WHITE MONITOR
REAR CONN PANEL ASSY	AVIF ASSY	Audio and Video Interface Assembly	1	
	BVIF ASSY	Video Interface Assembly for B/W Console		1
	CNTIF ASSY	Control Signal Interface Assembly	1	1



CARD CAGE SLOT	NAME	DESCRIPTIONS	CONSOLE TYPE	
			2 SLOTS	3 SLOTS
PROBE CONN SET ASSY	PRAG ASSY	Preamplifier Group Assembly	1	1
	DCON ASSY	Dual Connector Assembly	1	
	CONN1 ASSY	Connector 1 Assembly		1

5-8 CIRCUIT BOARD DESCRIPTION (continued)

TABLE 5-1
CIRCUIT BOARD DESCRIPTION (continued)

LOCATION	NAME	DESCRIPTIONS	QTY.
ECG PANEL ASSY	PIOP ASSY	Physiological Signal Processor Assembly	(1)
POWER SUPPLY ASSY	LV UNIT	Low Voltage Unit	1
	HV ASSY	High Voltage Assembly	1
	SPWR ASSY	Subsidiary Power Assembly	1
	PCONT ASSY	Power Control Assembly	1
POWER SUPPLY ASSY2	LV2 UNIT	Low Voltage 2 Unit	1
	HV UNIT	High Voltage Unit	1
POWER SUPPLY ASSY3	LV3 UNIT	Low Voltage 3 Unit	1

TABLE 5-2
CIRCUIT BOARD VARIATIONS

BOARD NAME	VARIATIONS	NOTE	VERSION
TRDR ASSY	TRDR ASSY TRDR ASSY	2123305 , used for console with software version 2.11 or former. 2123305-2 , From console with software version 3.00. Old TRDR Assy (2123305) can be replaced with new TRDR Assy (2123305-2).	0 4 or 5
ASPR ASSY	ASPR ASSY ASPR ASSY  ASPR3 ASSY ASPR3 ASSY	2123603 , used for console with software version 2.11 or former. 2123603-2 , From console with software version 3.00. Old ASPR Assy (2123603) can be replaced with new ASPR Assy (2123603-2). 2192676 , From console with software version 4.01 or later. 2192676-2 , From console with software version 4.31. Old ASPR3 Assy (2192676) can be replaced with new ASPR3 Assy (2192676-2).	4 8, 9, or a d 12
DOPC ASSY	DOPC ASSY DOPC ASSY  DOPC2 ASSY DOPC3 ASSY	2123311-2 , used for console with software version 2.11 or former. 2123311-3 , From console with software version 3.00. Old DOPC Assy (2123311-2) can be replaced with new DOPC Assy (2123311-3). 2192564 , From console with software version 4.01 2248949 , From console with software version 4.31	1 4 or 5 8 c
TLMC ASSY	TLMC ASSY TLMC ASSY TLMC ASSY	P9525WY , used for console with software version 2.11 or former. 2158390 , From console with software version 3.00. Old TLMC Assy (P9525WY) can be replaced with new TLMC Assy (2158390). 2158390-2 Old TLMC Assy (P9525WY and 2158390) can be replaced with new TLMC Assy (2158390-2).	2 4 or 5 8 or 9 

5-8 CIRCUIT BOARD DESCRIPTION (continued)

TABLE 5-2
CIRCUIT BOARD VARIATIONS (continued)

BOARD NAME	VARIATIONS	NOTE	VERSION
VIDO ASSY	VIDO2 ASSY VIDO2 ASSY	2117032-2 2117032-3 , Applied to MVME147-010. Old VIDO2 ASSY (2117032-2) can be replaced with new VIDO2 ASSY (2117032-3).	3 8, 9 or a
VIPB ASSY	VIPB ASSY VIPB ASSY VIPB2 ASSY VIPB2 ASSY	P9525VA 2149141 , Applied to MVME147-010. Old VIPB ASSY (P9525VA) can be replaced with new VIPB ASSY (2149141). 2212616 , This assembly is available for the console with software version 3.40B or later (version 3.41B or later for CL console) 2212616-2 , Old VIPB2 ASSY (2212616) can be replaced with new VIPB2 ASSY (2212616-2).	1 4 or 5 8 or 9 c
VIPP ASSY	VIPP	2245652 , Available only for console with software version 5.01y or later.	0
VIDM ASSY	VIDM ASSY VIDM ASSY VIDM ASSY	2123337 2123337-2 , Applied to MVME147-010. Old VIDM ASSY (2123337) can be replaced with new VIDM ASSY (2123337-2). 2123337-3 , Applied to MVME147-010. Old VIDM ASSY (2123337-2) can be replaced with new VIDM ASSY (2123337-3).	0 4, 5 or 6 8, 9 or a
TDCB ASSY	TDCB ASSY TDCB ASSY TDCB ASSY	2123315 2123315-2 Old TDCB Assy (2123315) can be replaced with new TDCB Assy (2123315-2). 2123315-3 Old TDCB Assy (2123315 and 2123315-2) can be replaced with new TDCB Assy (2123315-3).	0 4, 5 or 6 26 or 28
DSCC ASSY	DSCC ASSY DSCC ASSY	2123313-2 2123313-3 Old DSCC Assy (2123313-2) can be replaced with new DSCC Assy (2123313-3).	4 8, 9, a, or b
PIOP ASSY	PIOP ASSY PIOP2 ASSY	Included in ECG Board Assy (P9522WZ) Included in ECG Board2 Assy (2207806)	2 4
MPU ASSY	MPU ASSY MPU ASSY MPU ASSY MPU ASSY MPU-A ASSY MPU-A ASSY	2123339 2123339-2 , From software version 3.00. Old MPU Assy can be replaced with new new MPU Assy (2123339-2) 2123339-3 , From software version 3.40. Old MPU Assy can be replaced with new new MPU Assy (2123339-3) 2123339-4 , From software version 4.01. Old MPU Assy can be replaced with new new MPU Assy (2123339-4). This assy has to be installed to use VIPB2 Assy on B/W console with software V3.40By 2195746 , For console with optional DICOM connection and software version 3.40 or later. MASC+ADPT2+MVME167-002B 2195746-2 , Old MPU-A Assy can be replaced with new new MPU Assy (2195746-2). This assy has to be installed to use VIPB2 Assy on B/W console with software V3.40By	NA NA NA NA NA NA

LIST OF ABBREVIATIONS

- 1 Stock item
- 2 Non stock item

6-1 RENEWAL PARTS

LOGIQ™ 400
MATERIAL LIST (1)

PART NAME	PART NO.	QUANTITY										DESCRIPTION	
OPERATOR CONSOLE ASSY	2127795	1										CFM, 120V, NTSC	VER. 2.11
OPERATOR CONSOLE ASSY	2127796		1									CFM, 220V, PAL	VER. 2.11
OPERATOR CONSOLE ASSY	2127794			1								CFM, 100V, NTSC	VER. 2.11
OPERATOR CONSOLE ASSY	2127800				1							CFM, 120V, NTSC	VER. 2.11
OPERATOR CONSOLE ASSY	2127801					1						CFM, 220V, PAL	VER. 2.11
OPERATOR CONSOLE ASSY	2127798						1					B/W, 120V, NTSC	VER. 2.11
OPERATOR CONSOLE ASSY	2127799							1				B/W, 220V, PAL	VER. 2.11
OPERATOR CONSOLE ASSY	2127797								1			B/W, 100V, NTSC	VER. 2.11
OPERATOR CONSOLE ASSY	2127802									1		B/W, 120V, NTSC	VER. 2.11
OPERATOR CONSOLE ASSY	2127803										1	B/W, 220V, PAL	VER. 2.11
PROBE CABLE ARM	P9514FT	1	1	1	1	1	1	1	1	1	1		
ARM SPACER	P9510HK	1	1	1	1	1	1	1	1	1	1		
MTZ HOLDER ASSY	P9522XM	1	1		1	1	1	1			1		
SWIVEL LOCK	U0144AE	1					1						
CRT FILTER	P9522WD				1	1							
VINYL COVER ASSY	2131324			1									
B/W VINYL COVER ASSY	2131427									1			
128MB MO DISK	2131693	1	1	1	1	1	1	1	1	1	1		
3.5 INCH MO CLEANING KIT	U0055ZA	1	1	1	1	1	1	1	1	1	1		
AQUASONIC GEL	U0403BD	1	1	1	1	1	1	1	1	1	1		
OPERATION MANUAL	2129779-100				1	1					1	1	English
OPERATION MANUAL	2129779-140			1							1		Japanese
QUICK GUIDE	2143806-140			1							1		Japanese
SERVICE MANUAL	2127661	1	1		1	1	1	1	1	1	1		
USA (RA1408AK, RA1408AL)											ASIA (RA1403BH)		
EUROPE (RA1404AH, RA1404AG)											ASIA (RA1401BA)		
JAPAN (RA1406AJ)											JAPAN (RA1407BJ)		
ASIA (RA1400AA)											EUROPE (RA1405BH)		
ASIA (RA1402AH)											USA (RA1409BK)		

6-1 RENEWAL PARTS (Continued)

LOGIQ™ 400
MATERIAL LIST (2)

PART NAME	PART NO.	QUANTITY										DESCRIPTION		
OPERATOR CONSOLE ASSY	2164515	1											CFM, 120V, NTSC	VER. 3.00
OPERATOR CONSOLE ASSY	2164516		1										CFM, 220V, PAL	VER. 3.00
OPERATOR CONSOLE ASSY	2164514			1									CFM, 100V, NTSC	VER. 3.00
OPERATOR CONSOLE ASSY	2164520				1								CFM, 120V, NTSC	VER. 3.00
OPERATOR CONSOLE ASSY	2164521					1							CFM, 220V, PAL	VER. 3.00
OPERATOR CONSOLE ASSY	2164518						1						B/W, 120V, NTSC	VER. 3.00
OPERATOR CONSOLE ASSY	2164519							1					B/W, 220V, PAL	VER. 3.00
OPERATOR CONSOLE ASSY	2164517								1				B/W, 100V, NTSC	VER. 3.00
OPERATOR CONSOLE ASSY	2164522									1			B/W, 120V, NTSC	VER. 3.00
OPERATOR CONSOLE ASSY	2164523										1		B/W, 220V, PAL	VER. 3.00
PROBE CABLE ARM	P9514FT	1	1	1	1	1	1	1	1	1	1	1		
ARM SPACER	P9510HK	1	1	1	1	1	1	1	1	1	1	1		
MTZ HOLDER ASSY	P9522XM	1	1		1	1	1	1				1		
SWIVEL LOCK	U0144AE	1						1						
CRT FILTER	P9522WD				1	1								
VINYL COVER ASSY	2131324			1										
B/W VINYL COVER ASSY	2131427								1					
128MB MO DISK	2131693	1	1	1	1	1	1	1	1	1	1	1		
3.5 INCH MO CLEANING KIT	U0055ZA	1	1	1	1	1	1	1	1	1	1	1		
3.5 INCH MO HEAD CLEANER	2148392	1	1	1	1	1	1	1	1	1	1	1		
AQUASONIC GEL	U0403BD	1	1	1	1	1	1	1	1	1	1	1		
OPERATION MANUAL	2156967-100				1	1					1	1	English	
OPERATION MANUAL	2156967-140			1							1		Japanese	
QUICK GUIDE	2137070-100										1	1	English	
QUICK GUIDE	2143806-140			1							1		Japanese	
SERVICE MANUAL	2127661	1	1		1	1	1	1			1	1		
COLOR ENHANCEMENT S/W	2165097		1	1										
MULTI-GESTATION CALC.S/W	2165098		1	1	1	1			1			1		
ADVANCED VASCULAR	2165099			1	1	1				1	1	1		
CALCULATION S/W														
START-UP MD DISPLAY	2165100	1	1	1	1	1	1				1	1	1	
FETAL TREND S/W	2136313		1								1			
IMAGE ARCHIVE S/W	2136312		1											
CFM CAPTURE S/W	2136314		1											
USA (RA1410LD)														ASIA (RA1411LB)
EUROPE (RA1410LC)														ASIA (RA1411LA)
JAPAN (RA1411LE)														JAPAN (RA1411LF)
ASIA (RA1410LA)														EUROPE (RA1411LC)
ASIA (RA1410LB)														USA (RA1411LD)

6-1 RENEWAL PARTS (Continued)

LOGIQ™ 400
MATERIAL LIST (3)

PART NAME	PART NO.	QUANTITY										DESCRIPTION		
OPERATOR CONSOLE ASSY	2180829	1											CFM, 120V, NTSC	VER. 3.10
OPERATOR CONSOLE ASSY	2180830		1										CFM, 220V, PAL	VER. 3.10
OPERATOR CONSOLE ASSY	2180828			1									CFM, 100V, NTSC	VER. 3.10
OPERATOR CONSOLE ASSY	2180834				1								CFM, 120V, NTSC	VER. 3.10
OPERATOR CONSOLE ASSY	2180835					1							CFM, 220V, PAL	VER. 3.10
OPERATOR CONSOLE ASSY	2180832						1						B/W, 120V, NTSC	VER. 3.10
OPERATOR CONSOLE ASSY	2180833							1					B/W, 220V, PAL	VER. 3.10
OPERATOR CONSOLE ASSY	2180831								1				B/W, 100V, NTSC	VER. 3.10
OPERATOR CONSOLE ASSY	2180836									1			B/W, 120V, NTSC	VER. 3.10
OPERATOR CONSOLE ASSY	2180837										1		B/W, 220V, PAL	VER. 3.10
PROBE CABLE ARM	P9514FT	1	1	1	1	1	1	1	1	1	1	1		
ARM SPACER	P9510HK	1	1	1	1	1	1	1	1	1	1	1		
MTZ HOLDER ASSY	P9522XM	1	1		1	1	1	1	1	1	1	1		
SWIVEL LOCK	U0144AE	1						1						
CRT FILTER	P9522WD				1	1								
VINYL COVER ASSY	2131324			1										
B/W VINYL COVER ASSY	2131427								1					
128MB MO DISK	2131693	1	1	1	1	1	1	1	1	1	1	1		
3.5 INCH MO CLEANING KIT	U0055ZA	1	1	1	1	1	1	1	1	1	1	1		
3.5 INCH MO HEAD CLEANER	2148392	1	1	1	1	1	1	1	1	1	1	1		
AQUASONIC GEL	U0403BD	1	1	1	1	1	1	1	1	1	1	1		
OPERATION MANUAL	2177612-100				1	1					1	1	English	
OPERATION MANUAL	2177612-140			1						1			Japanese	
QUICK GUIDE	2137070-100									1	1		English	
QUICK GUIDE	2143806-140			1						1			Japanese	
SERVICE MANUAL	2127661	1	1		1	1	1	1	1	1	1	1		
COLOR ENHANCEMENT S/W	2165097		1	1										
MULTI-GESTATION CALC.S/W	2165098		1	1	1	1		1		1	1	1		
ADVANCED VASCULAR	2165099			1	1	1				1	1	1		
CALCULATION S/W														
START-UP MD DISPLAY	2165100	1	1	1	1	1	1	1	1	1	1	1		
FETAL TREND S/W	2136313		1							1				
IMAGE ARCHIVE S/W	2136312		1											
CFM CAPTURE S/W	2136314		1											
USA (RA1410LF, 2179111-2)													ASIA (RA1410LP, 2179111-10)	
EUROPE (RA1410LG, 2179111-3)													ASIA (RA1410LN, 2179111-9)	
JAPAN (RA1410LE, 2179111)													JAPAN (RA1410LH, 2179111-4)	
ASIA (RA1410LL, 2179111-7)													EUROPE (RA1410LK, 2179111-6)	
ASIA (RA1410LM, 2179111-8)													USA (RA1410LJ, 2179111-5)	

6-1 RENEWAL PARTS (Continued)

LOGIQ™ 400CL
MATERIAL LIST (4)

PART NAME	PART NO.	QUANTITY							DESCRIPTION
OPERATOR CONSOLE ASSY	2198442	1							CFM, 120V, NTSC (LOGIQ™ 400CL)
OPERATOR CONSOLE ASSY	2198443		1						CFM, 220V, PAL (LOGIQ™ 400CL)
OPERATOR CONSOLE ASSY	2197064			1					CFM, 100V, NTSC (LOGIQ™ 400CL)
OPERATOR CONSOLE ASSY	2198444				1				CFM, 120V, NTSC (LOGIQ™ 400CL)
OPERATOR CONSOLE ASSY	2198445					1			CFM, 220V, PAL (LOGIQ™ 400CL)
PROBE CABLE ARM	P9514FT	1	1	1	1	1			Software Version: 3.20
ARM SPACER	P9510HK	1	1	1	1	1			
MTZ HOLDER ASSY	P9522XM	1	1		1	1			
VINYL COVER ASSY	2131324			1					
128MB MO DISK	2131693	1	1	1	1	1			
3.5 INCH MO CLEANING KIT	U0055ZA	1	1	1	1	1			
3.5 INCH MO HEAD CLEANER	2148392	1	1	1	1	1			
AQUASONIC GEL	U0403BD	1	1	1	1	1			
OPERATION MANUAL	2202294-100				1	1			English
OPERATION MANUAL	2202294-140				1				Japanese
SERVICE MANUAL	2127661	1	1		1	1			
COLOR ENHANCEMENT S/W	2165097			1					
USA (RA1410CA, 2197063-2)									
EUROPE (RA1410CB, 2197063-3)									
JAPAN (RA1410CL, 2197063)									
ASIA (RA1410CC, 2197063-4)									
ASIA (RA1410CD, 2197063-5)									

6-1 RENEWAL PARTS (continued)

LOGIQ™ 400
MATERIAL LIST (5)

PART NAME	PART NO.	QUANTITY													DESCRIPTION			
		1	2	3	4	5	6	7	8	9	10	11	12	13				
OPERATOR CONSOLE ASSY	2212969	1															CFM, 120V, NTSC	VER. 3.40
OPERATOR CONSOLE ASSY	2212970		1														CFM, 220V, PAL	VER. 3.40
OPERATOR CONSOLE ASSY	2212968			1	1												CFM, 100V, NTSC	VER. 3.40
OPERATOR CONSOLE ASSY	2212974					1											CFM, 120V, NTSC	VER. 3.40
OPERATOR CONSOLE ASSY	2212975							1	1								CFM, 220V, PAL	VER. 3.40
OPERATOR CONSOLE ASSY	2212972									1							B/W, 120V, NTSC	VER. 3.40
OPERATOR CONSOLE ASSY	2212973										1						B/W, 220V, PAL	VER. 3.40
OPERATOR CONSOLE ASSY	2212971											1	1				B/W, 100V, NTSC	VER. 3.40
OPERATOR CONSOLE ASSY	2212876													1			B/W, 120V, NTSC	VER. 3.40
OPERATOR CONSOLE ASSY	2212977														1		B/W, 220V, PAL	VER. 3.40
PROBE CABLE ARM	P9514FT	1	1	1	1	1	1	1	1	1	1	1	1	1	1	1		
ARM SPACER	P9510HK	1	1	1	1	1	1	1	1	1	1	1	1	1	1	1		
MTZ HOLDER ASSY	P9522XM	1	1			1	1	1	1	1					1	1		
FOOT SWITCH	P9509NB					1	1											
CRT FILTER	P9522WD					1	1	1										
VINYL COVER ASSY	2131324			1	1													
B/W VINYL COVER ASSY	2131427											1	1					
V3.40Am PRESET MO	2225754	1								1								
128MB MO DISK	2131693		1	1	1	1	1	1	1	1	1	1	1	1	1	1		
3.5 INCH MO CLEANING KIT	U0055ZA		1	1	1	1	1	1	1	1	1	1	1	1	1	1		
3.5 INCH MO HEAD CLEANER	2148392		1	1	1	1	1	1	1	1	1	1	1	1	1	1		
AQUASONIC GEL	U0403BD		1	1	1	1	1	1	1	1	1	1	1	1	1	1		
3 PROBE PORT OPTION	2177136										1							
MVME167 OPT. (PRO)	2220455		1	1			1	1	1									
OPERATION MANUAL	2209830-100							1	1	1					1	1	English	
OPERATION MANUAL	2209830-140			1	1									1	1		Japanese	
QUICK GUIDE	2137070-100							1	1	1					1	1	English	
QUICK GUIDE	2211144-140			1	1									1	1		Japanese	
SERVICE MANUAL	2127661		1	1			1	1	1	1	1				1	1		
USA	(RA1412LB, 2212967-2)																	
EUROPE	(RA1413LE, 2212967-3)																	
JAPAN	(RA1412LA, 2212967)																	ASIA (RA1412LL, 2212967-10)
JAPAN	(RA1412LT, 2212967-12)																	ASIA (RA1412LK, 2212967-9)
ASIA	(RA1413LF, 2212967-7)																	JAPAN (RA1412LW, 2212967-13)
ASIA	(RA1413LG, 2212967-8)																	JAPAN (RA1412LG, 2212967-4)
India	(RA1412LF, 2212967-11)																	EUROPE (RA1412LJ, 2212967-6)
																		USA (RA1412LH, 2212967-5)

6-1 RENEWAL PARTS (continued)

LOGIQ™ 400CL

MATERIAL LIST (6)

PART NAME	PART NO.	QUANTITY							DESCRIPTION
OPERATOR CONSOLE ASSY	2213912	1							CFM, 120V, NTSC (LOGIQ™ 400CL)
OPERATOR CONSOLE ASSY	2213913		1						CFM, 220V, PAL (LOGIQ™ 400CL)
OPERATOR CONSOLE ASSY	2213911			1	1				CFM, 100V, NTSC (LOGIQ™ 400CL)
OPERATOR CONSOLE ASSY	2213914					1			CFM, 120V, NTSC (LOGIQ™ 400CL)
OPERATOR CONSOLE ASSY	2213915						1		CFM, 220V, PAL (LOGIQ™ 400CL)
									Software Version: 3.41
PROBE CABLE ARM	P9514FT	1	1	1	1	1	1		
ARM SPACER	P9510HK	1	1	1	1	1	1		
MTZ HOLDER ASSY	P9522XM	1	1			1	1		
VINYL COVER ASSY	2131324			1	1				
FOOT SWITCH	P9509NB						1	1	
128MB MO DISK	2131693	1	1	1	1	1	1		
3.5 INCH MO CLEANING KIT	U0055ZA	1	1	1	1	1	1		
3.5 INCH MO HEAD CLEANER	2148392	1	1	1	1	1	1		
AQUASONIC GEL	U0403BD	1	1	1	1	1	1		
OPERATION MANUAL	2209831-100						1	1	English
OPERATION MANUAL	2209831-140			1	1				Japanese
QUICK GUIDE	2211144-140			1	1				Japanese
SERVICE MANUAL	2127661	1	1			1	1		
COLOR ENHANCEMENT S/W	2165097			1	1				
ADVANCED VASCULAR S/W	2165099	1	1	1		1	1		
BASIC VASCULAR S/W	2220813	1	1	1		1	1		
OB/GYN CALCULATION S/W	2220814	1	1	1		1	1		
BASIC CARDIAC S/W	2220815	1	1	1		1	1		
B COLOR S/W	2220810	1	1	1		1	1		
REAL TIME DOP. TRACE S/W	2220811	1	1	1		1	1		
USA	(RA1412LN, 2213916-2)								
EUROPE	(RA1412LP, 2213916-3)								
JAPAN	(RA1412LM, 2213916)								
JAPAN	(RA1412LY, 2213916-6)								
ASIA	(RA1413LC, 2213916-4)							ASIA	(RA1413LD, 2213916-5)

6-1 RENEWAL PARTS (continued)

LOGIQ™ 400
MATERIAL LIST (7)

PART NAME	PART NO.	QUANTITY												DESCRIPTION	
		1	2	3	4	5	6	7	8	9	10	11	12		
OPERATOR CONSOLE ASSY	2239793	1												CFM, 120V, NTSC	VER. 4.01
OPERATOR CONSOLE ASSY	2242844		1											CFM, 220V, PAL	VER. 4.01
OPERATOR CONSOLE ASSY	2239794			1										CFM, 220V, PAL	VER. 4.01
OPERATOR CONSOLE ASSY	2239789				1	1								CFM, 100V, NTSC	VER. 4.01
OPERATOR CONSOLE ASSY	2239798						1							CFM, 120V, NTSC	VER. 4.01
OPERATOR CONSOLE ASSY	2239799							1						CFM, 220V, PAL	VER. 4.01
OPERATOR CONSOLE ASSY	2239796								1					B/W, 120V, NTSC	VER. 4.01
OPERATOR CONSOLE ASSY	2242845									1				B/W, 220V, PAL	VER. 4.01
OPERATOR CONSOLE ASSY	2239795										1	1		B/W, 100V, NTSC	VER. 4.01
OPERATOR CONSOLE ASSY	2239804												1	B/W, 120V, NTSC	VER. 4.01
OPERATOR CONSOLE ASSY	2239805												1	B/W, 220V, PAL	VER. 4.01
PROBE CABLE ARM	P9514FT	1	1	1	1	1	1	1	1	1	1	1	1		
ARM SPACER	P9510HK	1	1	1	1	1	1	1	1	1	1	1	1		
MTZ HOLDER ASSY	P9522XM	1	1	1			1	1	1	1			1		
FOOT SWITCH	P9509NB						1	1							
CRT FILTER	P9522WD						1	1							
VINYL COVER ASSY	2131324				1	1					1	1			
128MB MO DISK	2131693				1	1	1	1	1	1	1	1	1		
3.5 INCH MO CLEANING KIT	U0055ZA	1	1	1	1	1	1	1	1	1	1	1	1		
3.5 INCH MO HEAD CLEANER	2148392	1	1	1	1	1	1	1	1	1	1	1	1		
AQUASONIC GEL	U0403BD	1	1	1	1	1	1	1	1	1	1	1	1		
3 PROBE PORT OPTION	2177136				1										
OPERATION MANUAL	2230620-100						1	1				1	1	English	
OPERATION MANUAL	2230620-140				1	1					1	1		Japanese	
QUICK START GUIDE	2218743-100						1	1				1	1	English	
QUICK GUIDE	2211144-140				1	1					1	1		Japanese	
SERVICE MANUAL	2127661	1	1	1			1	1	1	1		1	1		
USA	(RA1413LJ, 2239787-2)														
USA	(RA1414LF, 2239787-15)													ASIA	(RA1413LZ, 2239787-10)
EUROPE	(RA1413LE, 2239787-3)													ASIA	(RA1414LA, 2239787-9)
JAPAN	(RA1413LL, 2239787)													JAPAN	(RA1414LE, 2239787-13)
JAPAN	(RA1414LC, 2239787-12)													JAPAN	(RA1414LB, 2239787-4)
ASIA	(RA1413LM, 2239787-7)													USA	(RA1414LG, 2239787-14)
ASIA	(RA1413LH, 2239787-8)													USA	(RA1413LY, 2239787-5)

6-1 RENEWAL PARTS (continued)

LOGIQ™ 400
MATERIAL LIST (7) (continued)

PART NAME	PART NO.	QUANTITY												DESCRIPTION
B COLOR	2220810	1	1	1	1	1	1							
REAL TIME DOPPLER TRACE	2220811	1	1	1	1	1	1							
SECTOR SCAN	2220812	1	1	1	1	1	1	1	1	1	1	1	1	
BASIC VASCULARCALC.	2220813	1	1	1	1	1	1	1	1	1		1	1	
OB/GYN CALC.	2220814	1	1	1	1	1	1	1	1	1		1	1	
BASIC CADIAC	2220815	1	1	1	1	1	1	1	1	1		1	1	
COLOR ENHANCEMENT S/W	2165097	1	1	1	1	1	1	1	1					
MULTI-GESTATION CALC.S/W	2165098			1	1	1	1	1				1	1	
ADVANCED VASCULAR CALCULATION S/W	2165099			1		1	1			1		1	1	
START-UP MD DISPLAY	2165100	1	1	1	1	1	1	1	1	1	1	1	1	
FETAL TREND S/W	2136313			1										
IMAGE ARCHIVE S/W	2136312			1										
CFM CAPTURE S/W	2136314			1										
Power Doppler Imaging S/W	2136317					1	1							
Real Time Doppler Calc. S/W	2241560					1	1					1	1	
ACE-2 S/W	2241561	1	1	1	1	1	1	1	1	1	1	1	1	
USA	(RA1413LJ, 2239787-2)													
USA	(RA1414LF, 2239787-15)													ASIA (RA1413LZ, 2239787-10)
EUROPE	(RA1413LE, 2239787-3)													ASIA (RA1414LA, 2239787-9)
JAPAN	(RA1413LL, 2239787)													JAPAN (RA1414LE, 2239787-13)
JAPAN	(RA1414LC, 2239787-12)													JAPAN (RA1414LB, 2239787-4)
ASIA	(RA1413LM, 2239787-7)													USA (RA1414LG, 2239787-14)
ASIA	(RA1413LH, 2239787-8)													USA (RA1413LY, 2239787-5)

6-1 RENEWAL PARTS (continued)

LOGIQ™ 400CL

MATERIAL LIST (8)

PART NAME	PART NO.	QUANTITY								DESCRIPTION	
OPERATOR CONSOLE ASSY	2239833	1									CFM, 120V, NTSC (LOGIQ™ 400CL)
OPERATOR CONSOLE ASSY	2239834		1								CFM, 220V, PAL (LOGIQ™ 400CL)
OPERATOR CONSOLE ASSY	2239832			1	1						CFM, 100V, NTSC (LOGIQ™ 400CL)
OPERATOR CONSOLE ASSY	2239835					1					CFM, 120V, NTSC (LOGIQ™ 400CL)
OPERATOR CONSOLE ASSY	2239836							1			CFM, 220V, PAL (LOGIQ™ 400CL) Software Version: 4.02
PROBE CABLE ARM	P9514FT	1	1	1	1	1	1				
ARM SPACER	P9510HK	1	1	1	1	1	1				
MTZ HOLDER ASSY	P9522XM	1	1				1	1			
VINYL COVER ASSY	2131324			1	1						
FOOT SWITCH	P9509NB							1	1		
128MB MO DISK	2131693	1	1	1	1	1	1				
3.5 INCH MO CLEANING KIT	U0055ZA	1	1	1	1	1	1				
3.5 INCH MO HEAD CLEANER	2148392	1	1	1	1	1	1				
AQUASONIC GEL	U0403BD	1	1	1	1	1	1				
OPERATION MANUAL	2230620-100							1	1		English
OPERATION MANUAL	2241837-140			1	1						Japanese
QUICK GUIDE	2211144-140			1	1						Japanese
SERVICE MANUAL	2127661	1	1					1	1		
COLOR ENHANCEMENT S/W	2165097				1	1					
ADVANCED VASCULAR S/W	2165099	1	1	1				1	1		
BASIC VASCULAR S/W	2220813	1	1	1				1	1		
OB/GYN CALCULATION S/W	2220814	1	1	1				1	1		
BASIC CARDIAC S/W	2220815	1	1	1				1	1		
B COLOR S/W	2220810	1	1	1				1	1		
REAL TIME DOP. TRACE S/W	2220811	1	1	1				1	1		
MVME167 OPT. (PRO)	2220455			1				1	1		
USA	(RA1413LP, 2239831-2)										
EUROPE	(RA1413LN, 2239831-3)										
JAPAN	(RA1413LT, 2239831)										
JAPAN	(RA1414LD, 2239831-6)										
ASIA	(RA1413LS, 2239831-4)									ASIA	(RA1413LR, 2239831-5)

6-1 RENEWAL PARTS (continued)

LOGIQ™ 400
MATERIAL LIST (9)

PART NAME	PART NO.	QUANTITY										DESCRIPTION		
OPERATOR CONSOLE ASSY	2250253	1											CFM, 120V, NTSC	VER. 4.31
OPERATOR CONSOLE ASSY	2250263		1										CFM, 220V, PAL	VER. 4.31
OPERATOR CONSOLE ASSY	2250254			1									CFM, 220V, PAL	VER. 4.31
OPERATOR CONSOLE ASSY	2250251				1	1							CFM, 100V, NTSC	VER. 4.31
OPERATOR CONSOLE ASSY	2250259						1						CFM, 120V, NTSC	VER. 4.31
OPERATOR CONSOLE ASSY	2250260							1					CFM, 220V, PAL	VER. 4.31
OPERATOR CONSOLE ASSY	2250265								1				MD, 120V, NTSC	VER. 4.31
OPERATOR CONSOLE ASSY	2250267									1			MD, 220V, PAL	VER. 4.31
PROBE CABLE ARM	P9514FT	1	1	1	1	1	1	1	1	1	1	1		
ARM SPACER	P9510HK	1	1	1	1	1	1	1	1	1	1	1		
MTZ HOLDER ASSY	P9522XM	1	1	1				1	1	1	1	1		
FOOT SWITCH	P9509NB							1	1	1	1	1		
CRT FILTER	P9522WD							1	1	1	1	1		
VINYL COVER ASSY	2131324				1	1								
128MB MO DISK	2131693				1	1	1	1	1	1	1	1		
3.5 INCH MO CLEANING KIT	U0055ZA	1	1	1	1	1	1	1	1	1	1	1		
3.5 INCH MO HEAD CLEANER	2148392	1	1	1	1	1	1	1	1	1	1	1		
AQUASONIC GEL	U0403BD	1	1	1	1	1	1	1	1	1	1	1		
3 PROBE PORT OPTION	2177136				1			1	1					
OPERATION MANUAL	2250488-100							1	1	1	1	1	English	
OPERATION MANUAL	2250488-140					1	1						Japanese	
QUICK START GUIDE	2237879-100							1	1	1	1	1	English	
QUICK GUIDE	2211144-140					1	1						Japanese	
SERVICE MANUAL	2127661	1	1	1				1	1	1	1	1		
USA	(H42152LE, 2250249-3)													
USA	(H42152LF, 2250249-4)												ASIA	(H42152LM, 2250249-9)
EUROPE	(H42152LB, 2250249-5)												ASIA	(H42152LL, 2250249-8)
JAPAN	(H74202, 2250249)												ASIA	(H42152LK, 2250249-7)
JAPAN A TYPE	(H74232, 2250249-2)												ASIA	(H42152LJ, 2250249-6)

6-1 RENEWAL PARTS (continued)

LOGIQ™ 400
MATERIAL LIST (9) (continued)

PART NAME	PART NO.	QUANTITY								DESCRIPTION	
OPERATOR CONSOLE ASSY	2250256	1								B/W, 120V, NTSC	VER. 4.31
OPERATOR CONSOLE ASSY	2250264		1							B/W, 220V, PAL	VER. 4.31
OPERATOR CONSOLE ASSY	2250258			1						B/W, 220V, PAL	VER. 4.31
OPERATOR CONSOLE ASSY	2250255				1	1				B/W, 120V, NTSC	VER. 4.31
OPERATOR CONSOLE ASSY	2250261						1			B/W, 120V, NTSC	VER. 4.31
OPERATOR CONSOLE ASSY	2250262							1		B/W, 220V, PAL	VER. 4.31
PROBE CABLE ARM	P9514FT	1	1	1	1	1	1	1	1		
ARM SPACER	P9510HK	1	1	1	1	1	1	1	1		
MTZ HOLDER ASSY	P9522XM	1	1	1				1	1		
FOOT SWITCH	P9509NB							1	1		
VINYL COVER ASSY	2131324				1	1					
128MB MO DISK	2131693	1	1	1	1	1	1	1	1		
3.5 INCH MO CLEANING KIT	U0055ZA	1	1	1	1	1	1	1	1		
3.5 INCH MO HEAD CLEANER	2148392	1	1	1	1	1	1	1	1		
AQUASONIC GEL	U0403BD	1	1	1	1	1	1	1	1		
OPERATION MANUAL	2250488-100							1	1	English	
OPERATION MANUAL	2250488-140				1	1				Japanese	
QUICK START GUIDE	2237879-100							1	1	English	
QUICK GUIDE	2211144-140				1	1				Japanese	
SERVICE MANUAL	2127661	1	1	1				1	1		
USA	(H42152LG, 2250249-12)										
USA	(H42152LH, 2250249-13)										
EUROPE	(H42152LD, 2250249-14)										
JAPAN	(H74222, 2250249-10)									ASIA	(H42152LT, 2250249-16)
JAPAN A TYPE	(H74252, 2250249-11)									ASIA	(H42152LS, 2250249-15)

6-1 RENEWAL PARTS (continued)

LOGIQ™ 400CL
MATERIAL LIST (10)

PART NAME	PART NO.	QUANTITY							DESCRIPTION
OPERATOR CONSOLE ASSY	2255918	1							CFM, 120V, NTSC (LOGIQ™ 400CL)
OPERATOR CONSOLE ASSY	2255919		1						CFM, 220V, PAL (LOGIQ™ 400CL)
OPERATOR CONSOLE ASSY	2250271			1					CFM, 220V, PAL (LOGIQ™ 400CL)
OPERATOR CONSOLE ASSY	2250270				1	1			CFM, 100V, NTSC (LOGIQ™ 400CL) Software Version: 4.32
PROBE CABLE ARM	P9514FT	1	1	1	1	1			
ARM SPACER	P9510HK	1	1	1	1	1			
MTZ HOLDER ASSY	P9522XM	1	1	1					
VINYL COVER ASSY	2131324				1	1			
128MB MO DISK	2131693	1	1	1	1	1			
3.5 INCH MO CLEANING KIT	U0055ZA	1	1	1	1	1			
3.5 INCH MO HEAD CLEANER	2148392	1	1	1	1	1			
AQUASONIC GEL	U0403BD	1	1	1	1	1			
OPERATION MANUAL	2251967-140				1	1			Japanese
QUICK GUIDE	2211144-140				1	1			Japanese
SERVICE MANUAL	2127661	1	1	1					
USA (H42152LW, 2250269-4)									
USA (H42152LY, 2250269-5)									
EUROPE (H42152LC, 2250269-3)									
JAPAN (H74212, 2250269)									
JAPAN (H74242, 2250269-2)									

6-1 RENEWAL PARTS (continued)

LOGIQ™ 400
MATERIAL LIST (11)

PART NAME	PART NO.	QUANTITY								DESCRIPTION	
OPERATOR CONSOLE ASSY	2264468	1								CFM, 120V, NTSC	VER. 5.01
OPERATOR CONSOLE ASSY	2264469		1							CFM, 220V, PAL	VER. 5.01
OPERATOR CONSOLE ASSY	2264470			1						CFM, 220V, PAL	VER. 5.01
OPERATOR CONSOLE ASSY	2264467				1					CFM, 100V, NTSC	VER. 5.01
OPERATOR CONSOLE ASSY	2264471					1				CFM, 120V, NTSC	VER. 5.01
OPERATOR CONSOLE ASSY	2264472						1			CFM, 220V, PAL	VER. 5.01
OPERATOR CONSOLE ASSY	2264475							1		CFM, 220V, NTSC	VER. 5.01
PROBE CABLE ARM	P9514FT	1	1	1	1	1	1	1			
ARM SPACER	P9510HK	1	1	1	1	1	1	1			
MTZ HOLDER ASSY	P9522XM	1	1	1							
FOOT SWITCH	P9509NB						1	1	1		
3 PROBE PORT OPTION	2177136				1	1	1	1			
128MB MO DISK	2131693				1	1	1	1			
3.5 INCH MO CLEANING KIT	U0055ZA	1	1	1	1	1	1	1			
3.5 INCH MO HEAD CLEANER	2148392	1	1	1	1	1	1	1			
AQUASONIC GEL	U0403BD	1	1	1	1	1	1	1			
ADD CINE MEMORY	P9523UC						1	1	1		
BASIC OP MANUAL	2260260-100						1	1	1		
ADVANCED OP MANUAL	2260261-100						1	1	1	English	
QUICK START GUIDE	2260274-100						1	1	1	English	
SERVICE MANUAL	2127661	1	1	1			1	1	1		
USA	(H42162LE, 22644652-2)										
USA	(H42162LF, 2264465-3)										
EUROPE	(H42162LG, 2264465-4)										
JAPAN	(H42162LD, 2264465)									KOREA	(H42162LL, 2264465-9)
ASIA	(H42162LJ, 2264465-5)									ASIA	(H42162LK, 2264465-6)

6-1 RENEWAL PARTS (continued)

LOGIQ™ 400

MATERIAL LIST (11) (continued)

PART NAME	PART NO.	QUANTITY								DESCRIPTION	
OPERATOR CONSOLE ASSY	2265936	1								B/W, 120V, NTSC	VER. 5.01
OPERATOR CONSOLE ASSY	2265937		1							B/W, 220V, PAL	VER. 5.01
OPERATOR CONSOLE ASSY	2265938			1						B/W, 220V, PAL	VER. 5.01
OPERATOR CONSOLE ASSY	2265935				1					B/W, 100V, NTSC	VER. 5.01
OPERATOR CONSOLE ASSY	2265939					1				B/W, 120V, NTSC	VER. 5.01
OPERATOR CONSOLE ASSY	2265940						1			B/W, 220V, PAL	VER. 5.01
OPERATOR CONSOLE ASSY	2265941							1		B/W, 220V, NTSC	VER. 5.01
PROBE CABLE ARM	P9514FT	1	1	1	1	1	1	1			
ARM SPACER	P9510HK	1	1	1	1	1	1	1			
MTZ HOLDER ASSY	P9522XM	1	1	1							
FOOT SWITCH	P9509NB					1	1	1			
3 PROBE PORT OPTION	2177136				1	1	1	1			
128MB MO DISK	2131693				1	1	1	1			
3.5 INCH MO CLEANING KIT	U0055ZA	1	1	1	1	1	1	1			
3.5 INCH MO HEAD CLEANER	2148392	1	1	1	1	1	1	1			
AQUASONIC GEL	U0403BD	1	1	1	1	1	1	1			
BASIC OP MANUAL	2260260-100					1	1	1			
ADVANCED OP MANUAL	2260261-100					1	1	1		English	
QUICK START GUIDE	2260274-100					1	1	1		English	
SERVICE MANUAL	2127661	1	1	1		1	1	1			
USA	(H42162LM, 2264465-11)										
USA	(H42162LP, 2264465-12)										
EUROPE	(H42162LR, 2264465-14)										
JAPAN	(H42162LM, 2264465-11)									KOREA	(H42162LB, 2264465-17)
ASIA	(H42162LS, 2264465-15)									ASIA	(H42172LA, 2264465-16)

6-1 RENEWAL PARTS (continued)

LOGIQ™ 400CL
MATERIAL LIST (12)

PART NAME	PART NO.	QUANTITY							DESCRIPTION
OPERATOR CONSOLE ASSY	2265944	1							CFM, 220V, PAL (LOGIQ™400CL) CFM, 120V, NTSC (LOIGQ™400CL) CFM, 220V, PAL (LOGIQ™400CL) CFM, 220V, NTSC (LOGIQ™400CL) Software Version: 5.01
OPERATOR CONSOLE ASSY	2265945		1						
OPERATOR CONSOLE ASSY	2265946			1					
OPERATOR CONSOLE ASSY	2265947				1				
PROBE CABLE ARM	P9514FT	1	1	1	1			English English	
ARM SPACER	P9510HK	1	1	1	1				
MTZ HOLDER ASSY	P9522XM	1	1	1	1				
FOOT SWITCH	P9509NB		1	1	1				
128MB MO DISK	2131693	1	1	1	1				
3.5 INCH MO CLEANING KIT	U0055ZA	1	1	1	1				
3.5 INCH MO HEAD CLEANER	2148392	1	1	1	1				
AQUASONIC GEL	U0403BD	1	1	1	1				
BASIC OP MANUAL	2260260-100	1	1	1	1				
ADVANCED OP MANUAL	2260261-100	1	1	1	1				
QUICK START GUIDE	2260274-100	1	1	1	1				
SERVICE MANUAL	2127661	1	1	1	1				
EUROPE	(H42172LC, 2265942)								
ASIA	(H42172LD, 2262942-2)								
ASIA	(H42172LE, 2265942-3)								
KOREA	(H42172LF, 2265942-4)								

OPERATOR CONSOLE ASSY

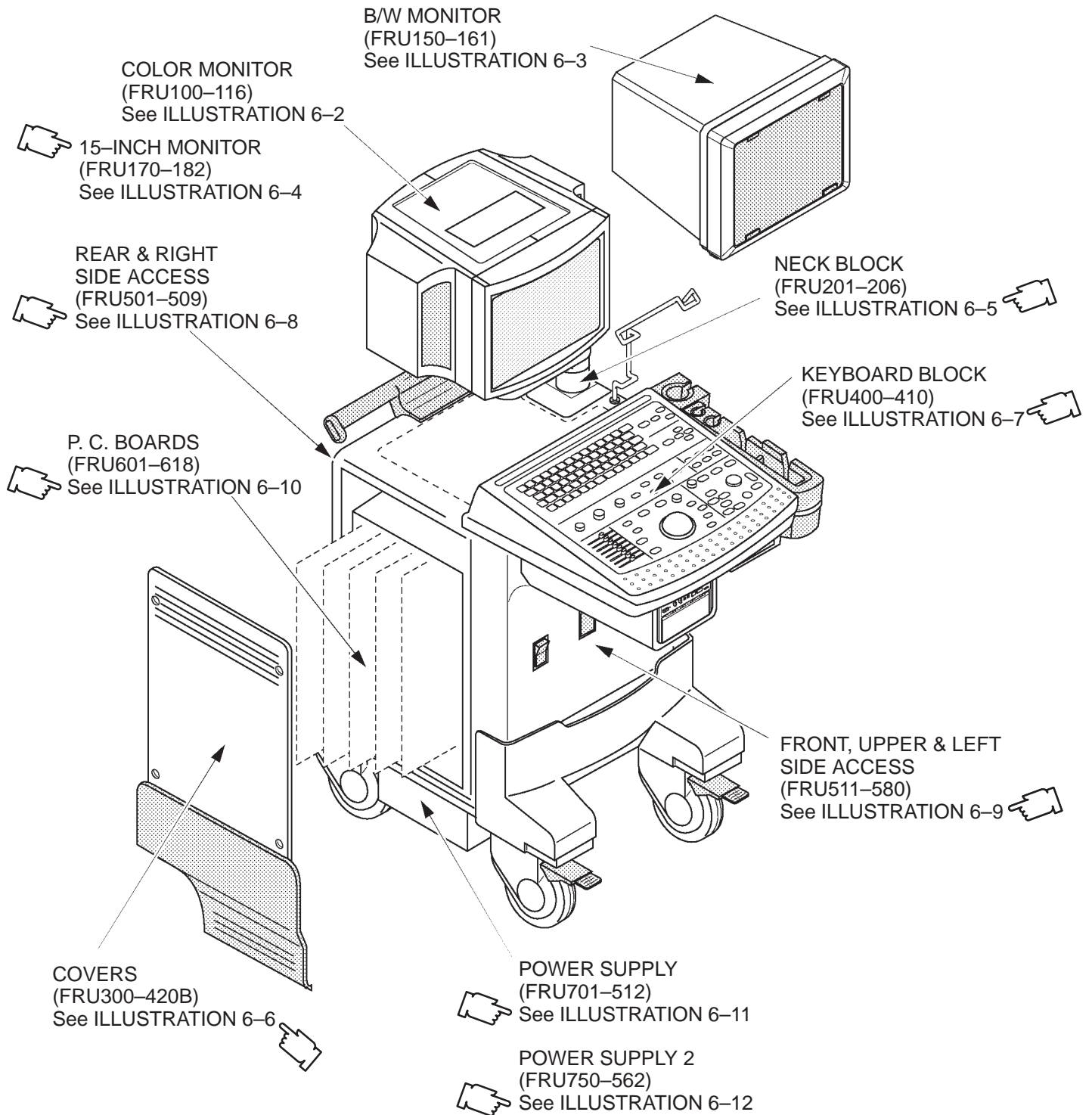

LOGIQ™ 400 CONSOLE
ILLUSTRATION 6-1

OPERATOR CONSOLE ASSY 1/12

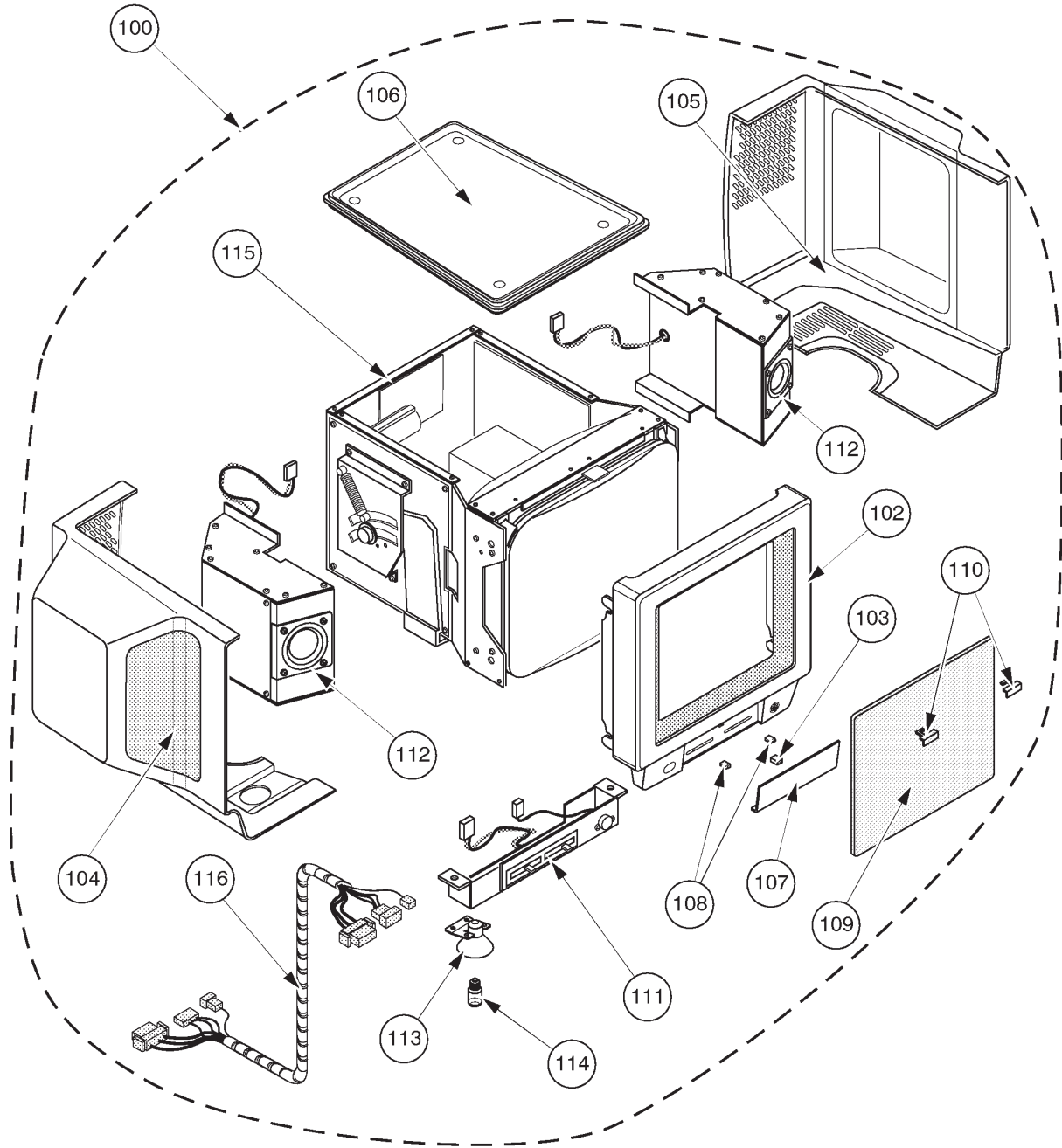

EXPLODED VIEW (a)
COLOR MONITOR
ILLUSTRATION 6-2

OPERATOR CONSOLE ASSY

2127794 – 2127803	: V2.11
2164514 – 2164523	: V3.00
2180828 – 2180837	: V3.10
2212968 – 2212977	: V3.40
2239789, 2239793 – 2239799, 2239804, 2239805	: V4.01
2250251, 2250253 – 2250256, 2250258 – 2250267	: V4.31
2197064, 2198442 – 2198445	: LOGIQ™ 400CL, V3.20
2213911 – 2213915	: LOGIQ™ 400CL, V3.41
2239832 – 2239836	: LOGIQ™ 400CL, V4.02
2250270, 2250271, 2255918, 2255919	: LOGIQ™ 400CL, V4.32

MATERIAL LIST (1/12)

FRU NO.	PART NAME	PART NO.	QTY.	FRU	DESCRIPTION	SECTION FOR REFERENCE
	COLOR MONITOR BLOCK					
100	MONITOR ASSY	2126883	1	1	Only for console with software V2.11 or former. excluding FRU109, 110	6-2-1
	MONITOR ASSY	2162081-2	1	1	Available for all console	6-2-1
	MONITOR ASSY	2200223	1	1	For LOGIQ™ 400CL: 2197064, 2198442-198445, 2213911-2213915, 2239832-2239836, 2250270, 2250271, 225918, and 225919	6-2-1
101	MONITOR COVER SET	2128722	1	2	Only for console with software V2.11 or former. Including FRU102+103 +104+105+106+107	6-2-2
	MONITOR COVER SET	2162082-2	1	2	Available for all console	6-2-2
	MONITOR COVER SET	2203089	1	2	For LOGIQ™ 400CL: 2197064, 2198442-198445, 2213911-2213915, 2239832-2239836, 2250270, 2250271, 225918, and 225919	6-2-2
102	ESCUTCHEON ASSY	2126888	1	2	Only for console with software V2.11 or former.	6-2-2
	ESCUTCHEON ASSY	2162083	1	2	Available for all console Including four (4) different labels	6-2-2
	ESCUTCHEON ASSY	2200222	1	2	For LOGIQ™ 400CL: 2197064, 2198442-198445, 2213911-2213915, 2239832-2239836, 2250270, 2250271, 225918, and 225919	6-2-2

OPERATOR CONSOLE ASSY

2127794 – 2127803	: V2.11
2164514 – 2164523	: V3.00
2180828 – 2180837	: V3.10
2212968 – 2212977	: V3.40
2239789, 2239793 – 2239799, 2239804, 2239805	: V4.01
2250251, 2250253 – 2250256, 2250258 – 2250267	: V4.31
2197064, 2198442 – 2198445	: LOGIQ™ 400CL, V3.20
2213911 – 2213915	: LOGIQ™ 400CL, V3.41
2239832 – 2239836	: LOGIQ™ 400CL, V4.02
2250270, 2250271, 2255918, 2255919	: LOGIQ™ 400CL, V4.32

MATERIAL LIST (1/12) (continued)

FRU NO.	PART NAME	PART NO.	QTY.	FRU	DESCRIPTION	SECTION FOR REFERENCE
103	ESCUTCHEON LATCH	P9523ND	1	2		6-2-3
104	MONITOR COVER L ASSY	2168465	1	2	including caution label	6-2-2
105	MONITOR COVER R ASSY	2168466	1	2	including caution label	6-2-2
106	MONITOR COVER TOP	P9523NH	1	2	including caution label	6-2-2
107	ESCUTCHEON FRONT DOOR	P9524JJ	1	1		6-2-4
	ESCUTCHEON FRONT DOOR	2193942	1	1	For LOGIQ™ 400CL: 2197064, 2198442-198445, 2213911-2213915, 2239832-2239836, 2250270, 2250271, 225918, and 225919	6-2-4
108	CRT CAP SET	P9523NB	1	2	2 Knobs and Lamp Switch Keytop	6-2-5
109	CRT FILTER	P9522WD	1	2	includes FRU110	6-2-6
110	CRT FILTER CLAMP SET	P9523NC	1	2		6-2-6
111	ACCESSORY ASSY	2114190	1	2	Left and right speakers	6-2-7
112	SPEAKER ASSY	P9522WA	1	1	are interchangeable	6-2-8
113	CRT LAMP ASSY	P9522WC	1	2	Without CRT lamp (FRU114)	6-2-9
114	CRT LAMP	U0107EH	1	1		6-2-9
115	CRT ASSY	2185634	1	2	Including Accessory Assy (FRU 111)	6-2-10
116	CRT CABLE SET	P9522MR	1	1	CB81 (CB35, CB36, and CB105)	6-2-11

This page is left blank intentionally.

OPERATOR CONSOLE ASSY 2/12

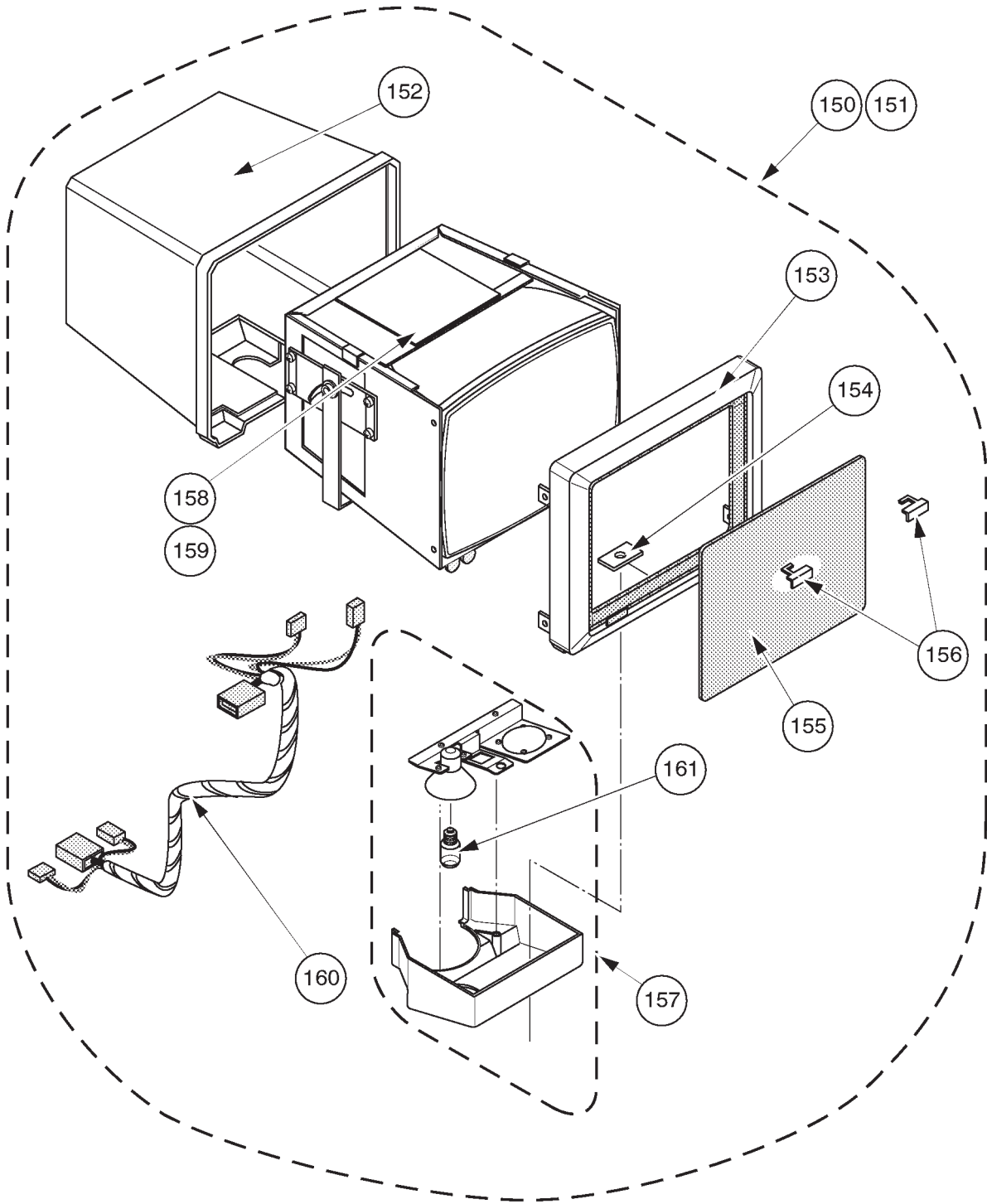

EXPLODED VIEW (b)
B/W MONITOR
ILLUSTRATION 6-3

OPERATOR CONSOLE ASSY

2127794 – 2127803	: V2.11
2164514 – 2164523	: V3.00
2180828 – 2180837	: V3.10
2212968 – 2212977	: V3.40
2239789, 2239793 – 2239799, 2239804, 2239805	: V4.01
2250251, 2250253 – 2250256, 2250258 – 2250267	: V4.31
2197064, 2198442 – 2198445	: LOGIQ™ 400CL, V3.20
2213911 – 2213915	: LOGIQ™ 400CL, V3.41
2239832 – 2239836	: LOGIQ™ 400CL, V4.02
2250270, 2250271, 2255918, 2255919	: LOGIQ™ 400CL, V4.32

MATERIAL LIST (2/12)

FRU NO.	PART NAME	PART NO.	QTY.	FRU	DESCRIPTION	SECTION FOR REFERENCE	
	B/W MONITOR BLOCK	Note: These Field Replaceable Units are used for the B/W console with the software V3.40 or ealier.					
150	MONITOR ASSY NTSC	2126873-2	1	1	Only for console with software V2.11 or former. FRU152+153+155+156+157+158+160	6-2-12	
	MONITOR ASSY NTSC	2164505	1	1	Available for all B/W console	6-2-12	
151	MONITOR ASSY PAL	2140516-2	1	1	Only for console with software V2.11 or former. FRU152+153+155+156+157+159+160	6-2-12	
	MONITOR ASSY PAL	2164506	1	1	Available for all B/W console	6-2-12	
152	MONITOR COVER	2140517	1	2		6-2-13	
153	ESCUTCHEON ASSY	2140518-2	1	2	Only for console with software V2.11 or former. includes Fixing Metal Plate	6-2-14	
	ESCUTCHEON ASSY	2164507	1	2	Available for all B/W console Including two (2) different labels	6-2-14	
154	FIXING METAL PLATE	2144045	1	1		6-2-15	
155	CRT FILTER	P9514BY	1	2		6-2-16	
156	CRT FILTER CLAMP SET	2140521-2	1	2		6-2-16	
157	MONITOR BOTTOM ASSY	2126884	1	2	Including CRT lamp (FRU 161)	6-2-17	

This page is left blank intentionally.

OPERATOR CONSOLE ASSY 3/12

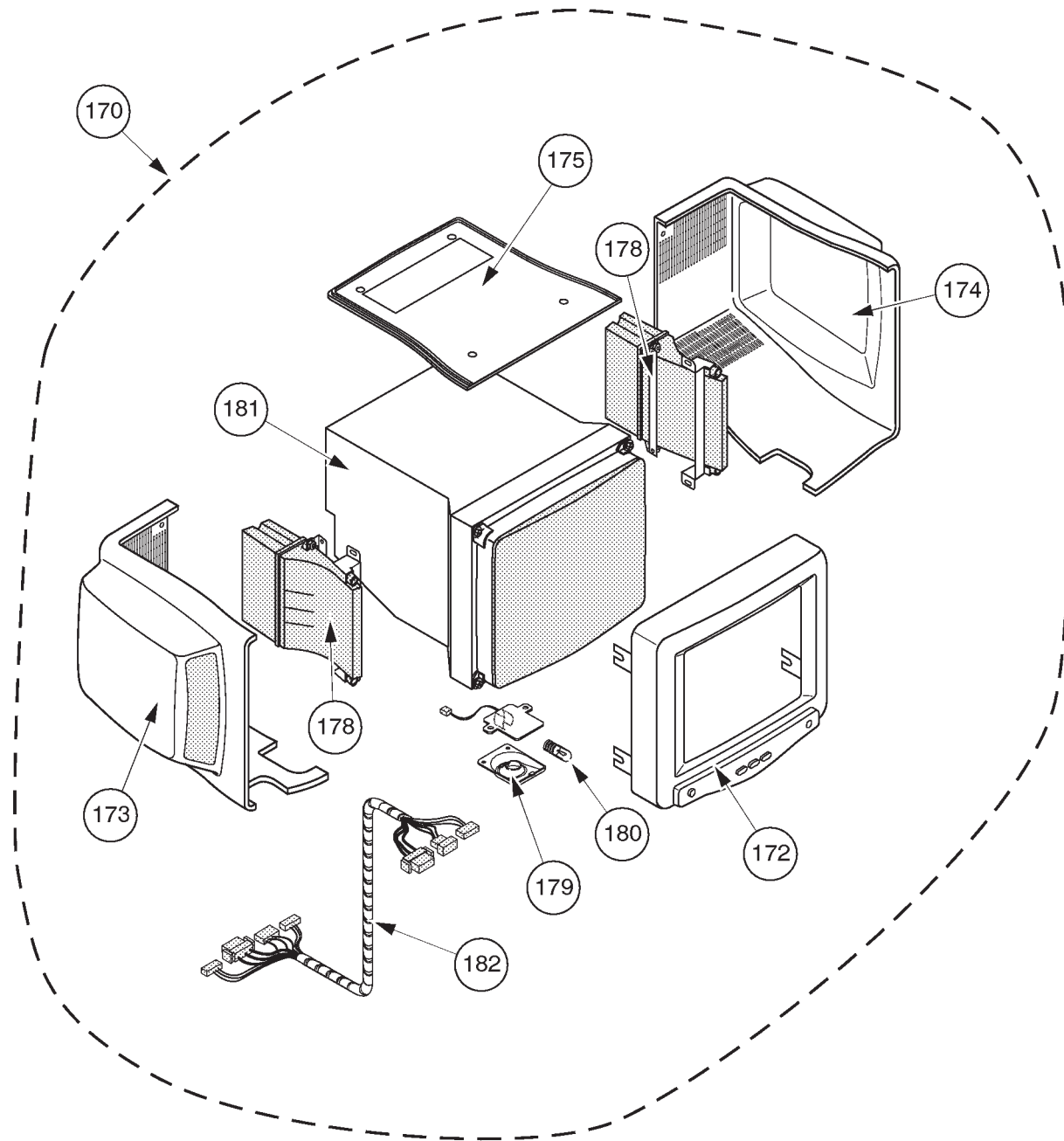

EXPLODED VIEW (c)
15-INCH MONITOR
ILLUSTRATION 6-4

OPERATOR CONSOLE ASSY

2264467 – 2264472, 2264475, 2265935 – 2265941
 2265944 – 2265947

: V5.01
 : LOGIQ™ 400CL, V5.01

MATERIAL LIST (3/12)

FRU NO.	PART NAME	PART NO.	QTY.	FRU	DESCRIPTION	SECTION FOR REFERENCE
170	MONITOR15 ASSY	2265743	1	1	Including FRU 171, 179, 180 and 181. 	6-2-21
	MONITOR15 CL ASSY	2267944	1	1	For LOGIQ™ 400CL: 2265944 – 2265947	
171	MONITOR15 COVER SET	2265559	1	2	Including FRU 172, 173, 174, and 175	6-2-22
	MONITRO15 CL COVER SET	2268023	1	2	For LOGIQ™ 400CL: 2265944 – 2265947	
172	ESCUTCHEON2 ASSY	2265744	1	2	Including two (2) different labels	6-2-22
	ESCUTCHEON CL ASSY	2267945	1	2	For LOGIQ™ 400CL: 2265944 – 2265947	
173	MONITOR COVER L2 ASSY	2250407	1	2	including caution label	6-2-22
174	MONITOR COVER R2 ASSY	2250409	1	2	including caution label	6-2-22
175	TRAY2 ASSY	2250410	1	2	including caution label	6-2-22
178	SPEAKER ASSY	2250413	1	1	left and right speakers are interchangeable.	6-2-23
179	LAMP SHADE2	2246213	1	2		6-2-24
180	TASK LAMP	U0107EH	1	1		6-2-24
181	CRT ASSY	2251431	1	2	including tilt mechanism	6-2-25
182	CRT CABLE SET	2251953	1	1		6-2-25

OPERATOR CONSOLE ASSY 4/12

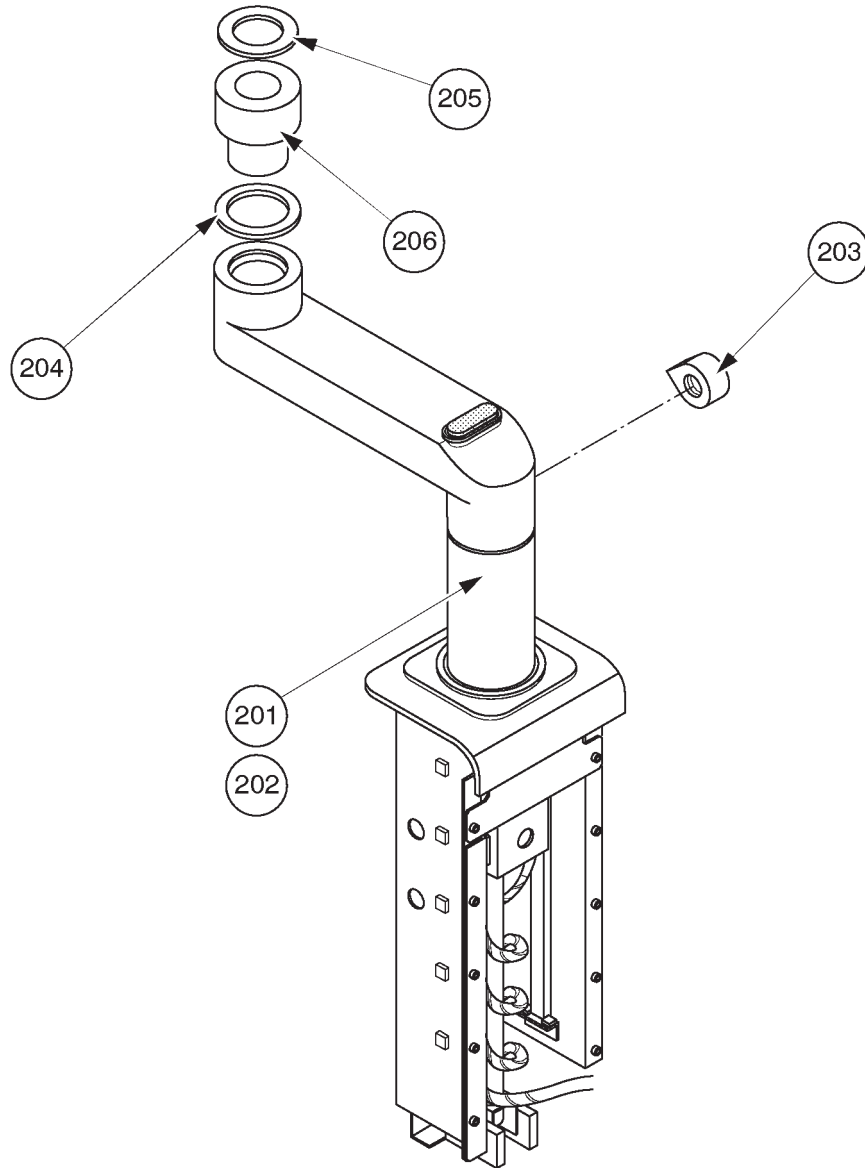

EXPLODED VIEW (c)
NECK BLOCK
ILLUSTRATION 6-5

OPERATOR CONSOLE ASSY 5/12

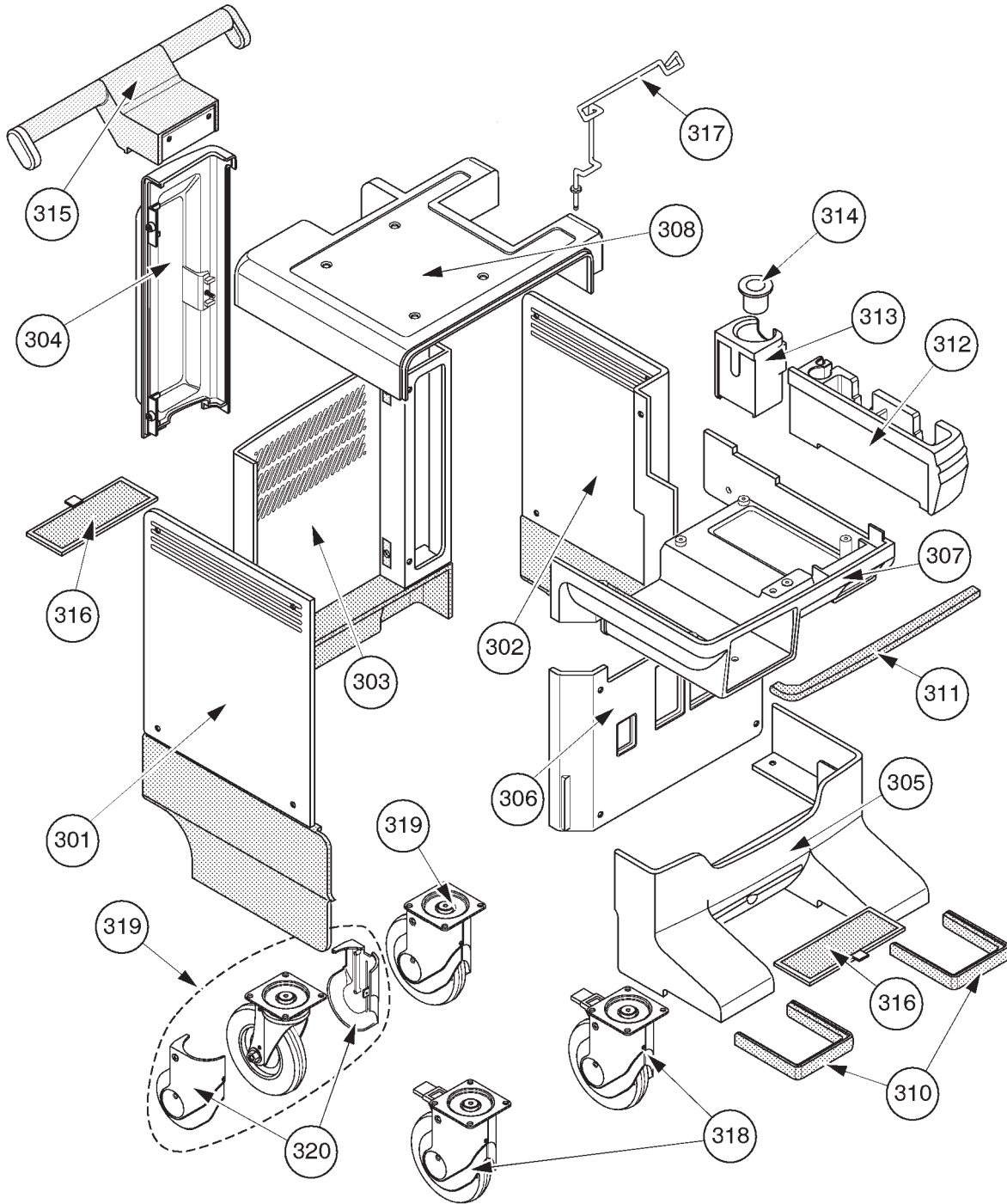





















EXPLODED VIEW (d)
COVERS
ILLUSTRATION 6-6

OPERATOR CONSOLE ASSY

2127794 – 2127803	: V2.11
2164514 – 2164523	: V3.00
2180828 – 2180837	: V3.10
2212968 – 2212977	: V3.40
2239789, 2239793 – 2239799, 2239804, 2239805	: V4.01
2250251, 2250253 – 2250256, 2250258 – 2250267	: V4.31
2264467 – 2264472, 2264475, 2265935 – 2265941	: V5.01
2197064, 2198442 – 2198445	: LOGIQ™ 400CL, V3.20
2213911 – 2213915	: LOGIQ™ 400CL, V3.41
2239832 – 2239836	: LOGIQ™ 400CL, V4.02
2250270, 2250271, 2255918, 2255919	: LOGIQ™ 400CL, V4.32
2265944 – 2265947	: LOGIQ™ 400CL, V5.01

MATERIAL LIST (5/12)

FRU NO.	PART NAME	PART NO.	QTY.	FRU	DESCRIPTION	SECTION FOR REFERENCE
	COVERS					
301	SIDE COVER LEFT	2115624	1	2		6-2-31 
	SIDE COVER L	2261596	1	2	From V5 System	6-2-31
302	SIDE COVER RIGHT	2115625	1	2		6-2-32 
	SIDE COVER R	2261595	1	2	From V5 System	6-2-32
303	REAR COVER	2115618	1	2	excluding Rear Door Assy	6-2-33 
	REAR COVER ASSY	2265557	1	2	From V5 System	6-2-33
304	REAR DOOR ASSY	2126886	1	2	Front Cover (P9524CE) +	6-2-34 
305	FRONT BASE COVER	P9523PC	1	2	Blind Label	6-2-35 
306	FRONT COVER	P9524CE	1	2		6-2-36 
	FRONT COVER ASSY	2211257	1	2		6-2-36 
	FRONT COVER ASSY	2253599	1	2	From V5 System	6-2-36
307	KEYBOARD BOTTOM COVER	P9524CN	1	2		6-2-37 
	KEYBOARD BOTTOM COVER	2251976	1	2	From V5 System	6-2-37
308	TOP COVER	2115623	1	2		6-2-38 
	TOP COVER	2261594	1	2	From V5 System	6-2-38
310	FRONT BUMPER SET	P9523NJ	1	2	left and right bumpers	6-2-39 
	BUMPER LONG ASSY	2268035	1	2	For V5 Tall Version. left and right bumper long are not interchangeable.	6-2-39
311	CORNER GUARD	P9524MJ	1	2	Keyboard bumper	6-2-40 
312	PROBE HOLDER	2135393	1	2		6-2-41 
313	GEL HOLDER	P9524MF	1	2		6-2-42 
314	GEL HOLDER BOTTOM	P9524MG	1	2		6-2-42 

OPERATOR CONSOLE ASSY

2127794 – 2127803	: V2.11
2164514 – 2164523	: V3.00
2180828 – 2180837	: V3.10
2212968 – 2212977	: V3.40
2239789, 2239793 – 2239799, 2239804, 2239805	: V4.01
2250251, 2250253 – 2250256, 2250258 – 2250267	: V4.31
2264467 – 2264472, 2264475, 2265935 – 2265941	: V5.01
2197064, 2198442 – 2198445	: LOGIQ™ 400CL, V3.20
2213911 – 2213915	: LOGIQ™ 400CL, V3.41
2239832 – 2239836	: LOGIQ™ 400CL, V4.02
2250270, 2250271, 2255918, 2255919	: LOGIQ™ 400CL, V4.32
2265944 – 2265947	: LOGIQ™ 400CL, V5.01

MATERIAL LIST (5/12) (Continued)

FRU NO.	PART NAME	PART NO.	QTY.	FRU	DESCRIPTION	SECTION FOR REFERENCE
	COVERS (CONTINUED)					
315	HANDLE	2115622	1	2		6-2-43
316	AIR FILTER	P9524BJ	1	2	This is one of 2 identical filters installed in a console	6-2-44
	AIR FILTER	2259546	1	2	This is one of 2 identical filters installed in a console	6-2-44
317	CABLE ARM	P9514FT	1	2		6-2-45
318	FRONT CASTER ASSY	P9523PD	1	2		6-2-46
319	REAR CASTER ASSY	P9523PE	1	2		6-2-47
320	CASTER COVER ASSY	P9523NE	1	2	covers for 1 caster	6-2-48
318B	FRONT CASTER R2 ASSY	2188701	1	2	These 3 items have no compatibility with old ones, FRU318, 319, and 320	6-2-46
319B	REAR CASTER R2 ASSY	2188703	1	2		6-2-47
320B	CASTER COVER R2 ASSY	2193548	1	2		6-2-48

This page is left blank intentionally.

■ OPERATOR CONSOLE ASSY 6/12

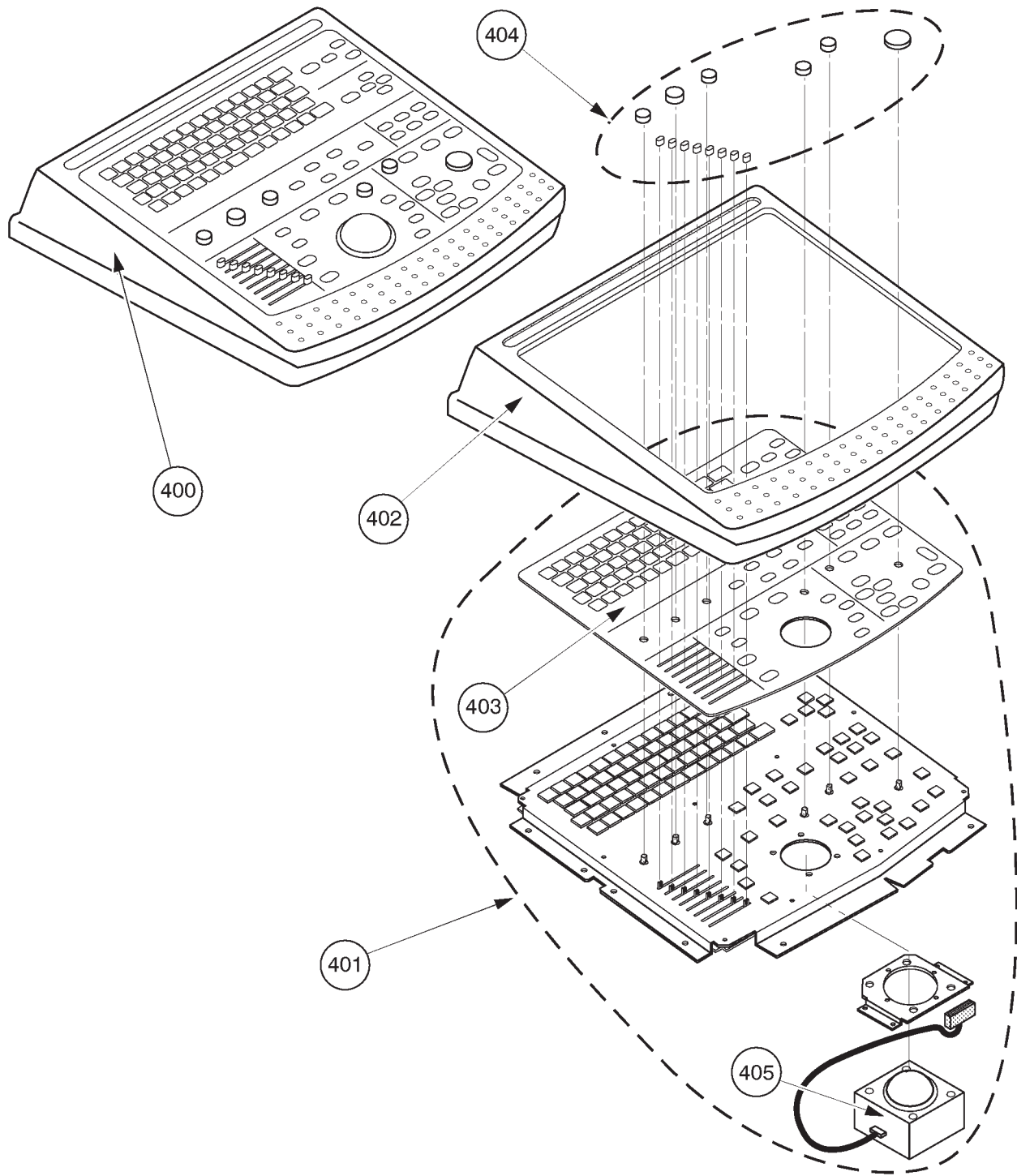















EXPLODED VIEW (e)
KEYBOARD BLOCK
ILLUSTRATION 6-7

OPERATOR CONSOLE ASSY

2127794 – 2127803	: V2.11
2164514 – 2164523	: V3.00
2180828 – 2180837	: V3.10
2212968 – 2212977	: V3.40
2239789, 2239793 – 2239799, 2239804, 2239805	: V4.01
2250251, 2250253 – 2250256, 2250258 – 2250267	: V4.31
2197064, 2198442 – 2198445	: LOGIQ™ 400CL, V3.20
2213911 – 2213915	: LOGIQ™ 400CL, V3.41
2239832 – 2239836	: LOGIQ™ 400CL, V4.02
2250270, 2250271, 2255918, 2255919	: LOGIQ™ 400CL, V4.32

MATERIAL LIST (6/12)

FRU NO.	PART NAME	PART NO.	QTY.	FRU	DESCRIPTION	SECTION FOR REFERENCE
	KEYBOARD BLOCK					
400	KEYBOARD PANEL ASSY	2126887	1	1		6-2-49 
	KEYBOARD PANEL ASSY	2200226	1	1	For LOGIQ™ 400CL	6-2-49 
	KEYBOARD PANEL2 ASSY	2206007	1	1	For MD console with software version 3.30 or later	6-2-49 
401	KEYBOARD ASSY	2144758	1	1		6-2-50 
	KEYBOARD ASSY	2200224	1	1	For LOGIQ™ 400CL	6-2-50 
	KEYBOARD2 ASSY	2206006	1	1	For MD console with software version 3.30 or later	6-2-50 
402	KEYBOARD COVER	2126999	1	2		6-2-50 
403	KEY SHEET	2144759	1	2	With metal plate	6-2-50 
	KEY SHEET	2200221	1	2	For LOGIQ™ 400CL	6-2-50 
404	KEYBOARD KNOB SET	2126998	1	2	6 Caps and 8 TGC knobs	6-2-51 
405	TRACKBALL	2141741	1	1		6-2-52 
410	GAIN ENCODER	2164871	1	2	40-click gain encoder. For console with software version 3.10 Cy or former	6-2-53 
	GAIN ENCODER	2216951	1	2	20-click gain encoder. For console with software version 3.30 Cy or former. 40-click encoder (2164871) can be replaced with this 20-click encoder (2216951).	6-2-53 
	GAIN ENCODER	2216954	1	2	20-click gain encoder. For console with software version 3.30 or later including V3.20 and V3.41 for LOGIQ™ 400CL	6-2-53 
411	ROTARY ENCODER	2216956	1	2	Other encoders	—

OPERATOR CONSOLE ASSY 7/12

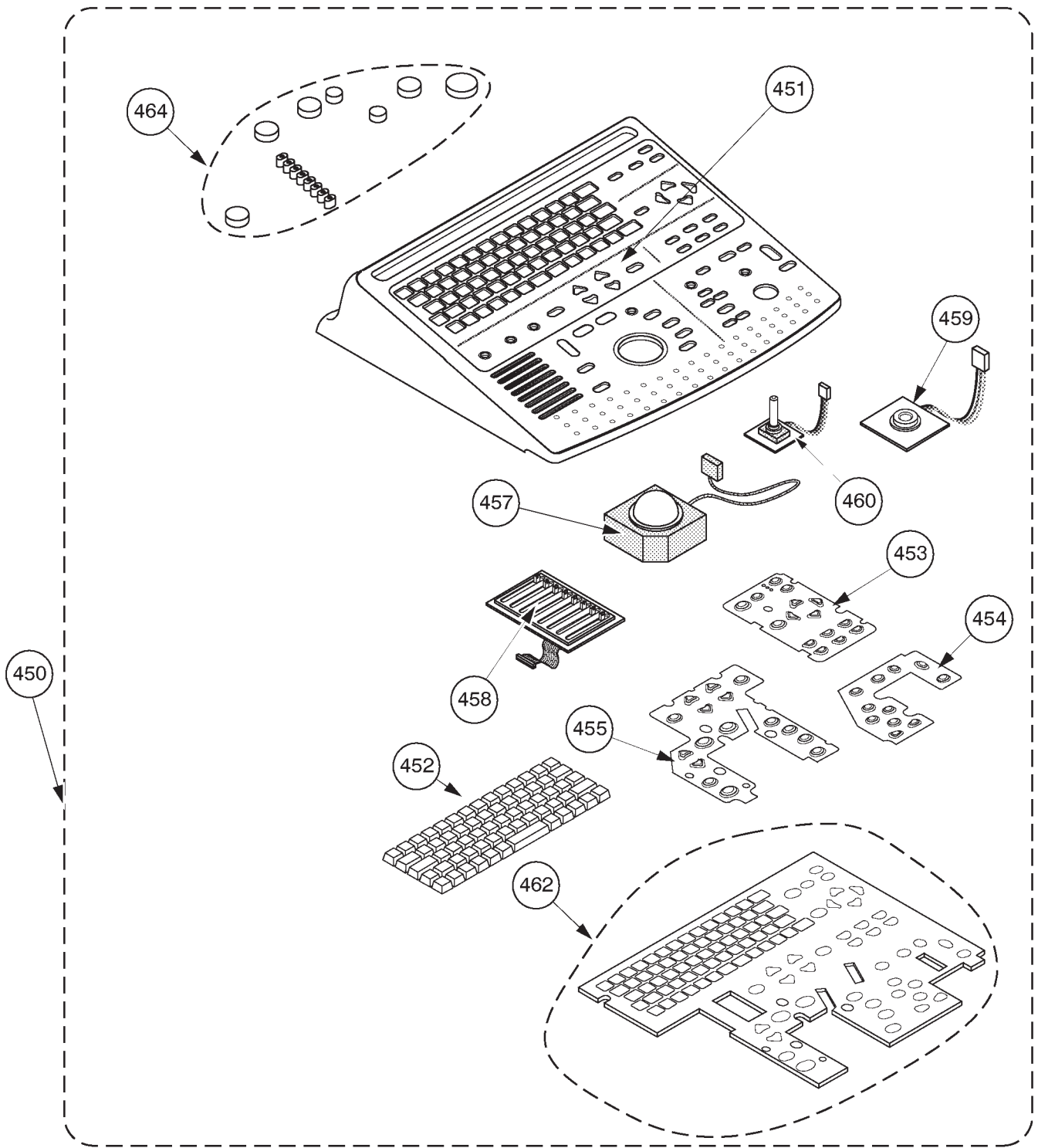

EXPLODED VIEW (e)
KEYBOARD BLOCK
ILLUSTRATION 6-8

OPERATOR CONSOLE ASSY

2264467 – 2264472, 2264475, 2265935 – 2265941
 2265944 – 2265947

: V5.01
 : LOGIQ™ 400CL, V5.01

MATERIAL LIST (7/12) (Continued)

FRU NO.	PART NAME	PART NO.	QTY.	FRU	DESCRIPTION	SECTION FOR REFERENCE
	KEYBOARD BLOCK					
450	KEYBOARD PANEL ASSY	2265687	1	1		6-2-54
	KEYBOARD PANEL CL ASSY	2267946	1	1	For LOGIQ™ 400CL	
451	KEYBOARD COVER 2 ASSY	2268922	1	2		6-2-55
	KEYBOARD COVER 2 CL ASSY	2268955	1	2	For LOGIQ™ 400CL	
452	RUBBER KEY AN_E	2268923	1	2	For English	6-2-55
	RUBBER KEY AN_R	2269083	1	2	For Russian	
	RUBBER KEY AN_G	2269084	1	2	For Greek	
	RUBBER KEY AN_T	2269085	1	2	For Turkish	
453	RUBBER KEY TOP MENU	2268926	1	2		6-2-55
454	RUBBER KEY MODE	2268927	1	2		6-2-55
455	RUBBER KEY TRACKBALL	2268928	1	2		6-2-55
457	TRACKBALL ASSY	2235387	1	1		6-2-57
458	TGC ASSY	2268929	1	1		6-2-58
459	FREEZE KEY ASSY	2268930	1	1		6-2-59
460	ROTARY ENCODER	2268931	1	2	20-click gain encoder.	6-2-60
462	SW PWB	2268932	1	1		6-2-55
464	KNOB SET	2126998	1	2		6-2-56

■ OPERATOR CONSOLE ASSY 8/12

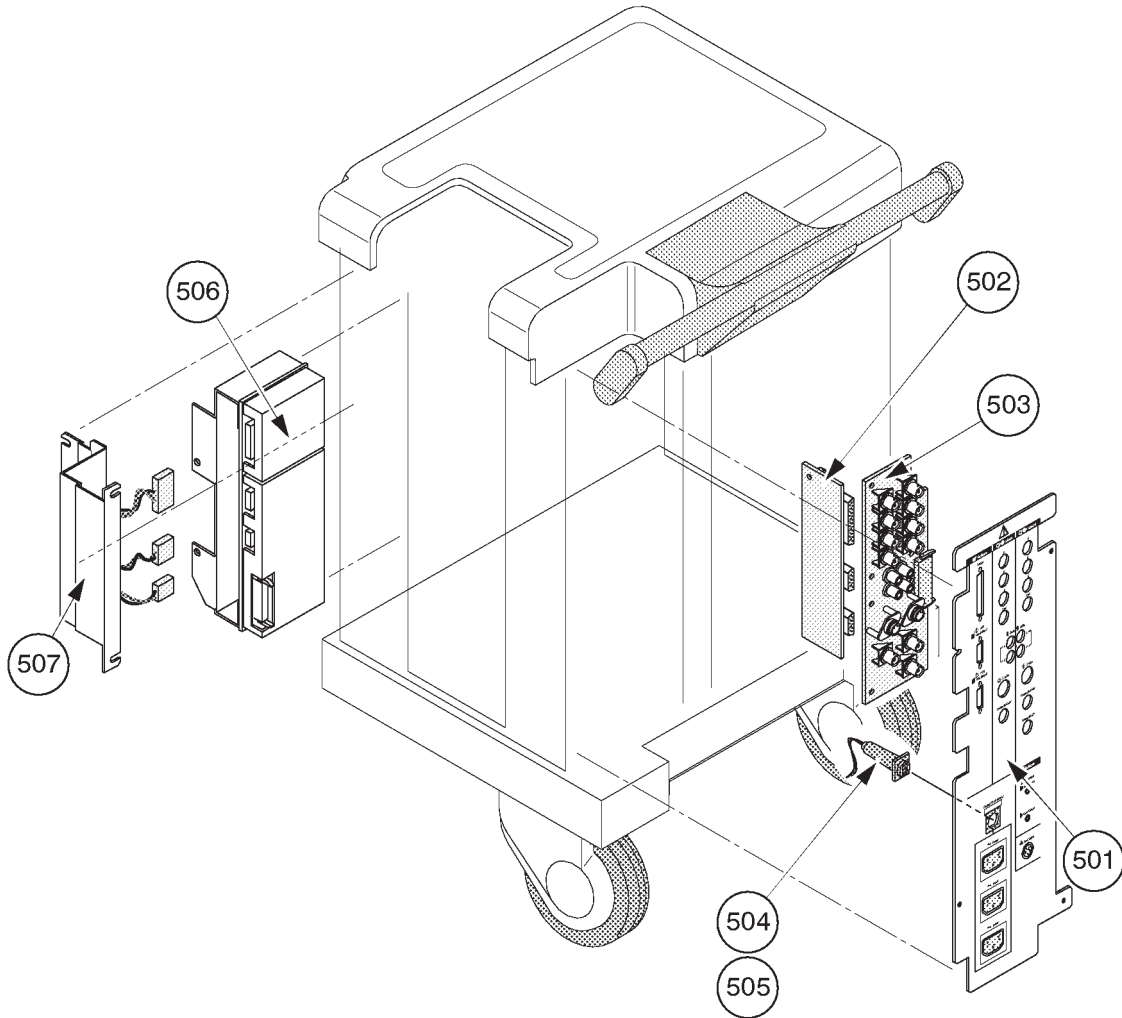







EXPLODED VIEW (f)
REAR & RIGHT SIDE ACCESS
ILLUSTRATION 6-9

OPERATOR CONSOLE ASSY

2127794 – 2127803	: V2.11
2164514 – 2164523	: V3.00
2180828 – 2180837	: V3.10
2212968 – 2212977	: V3.40
2239789, 2239793 – 2239799, 2239804, 2239805	: V4.01
2250251, 2250253 – 2250256, 2250258 – 2250267	: V4.31
2264467 – 2264472, 2264475, 2265935 – 2265941	: V5.01
2197064, 2198442 – 2198445	: LOGIQ™ 400CL, V3.20
2213911 – 2213915	: LOGIQ™ 400CL, V3.41
2239832 – 2239836	: LOGIQ™ 400CL, V4.02
2250270, 2250271, 2255918, 2255919	: LOGIQ™ 400CL, V4.32
2265944 – 2265947	: LOGIQ™ 400CL, V5.01

MATERIAL LIST (8/12)

FRU NO.	PART NAME	PART NO.	QTY.	FRU	DESCRIPTION	SECTION FOR REFERENCE
	REAR & RIGHT SIDE BLOCK					
501	REAR CONN PANEL ASSY	2115619	1	1	For 100V, CFM console	6-2-61 
	REAR CONN PANEL ASSY	2115620	1	1	For 120V, CFM console	
	REAR CONN PANEL ASSY	2115621	1	1	For 220V, CFM console	
	REAR CONN PANEL ASSY	2138819	1	1	For 100V, B/W console	
	REAR CONN PANEL ASSY	2138820	1	1	For 120V, B/W console	
	REAR CONN PANEL ASSY	2138821	1	1	For 220V, B/W console	
	REAR CONN PANEL2 ASSY	2115619-2	1	1	For 100V, CFM console	
	REAR CONN PANEL2 ASSY	2115620-2	1	1	For 120V, CFM console	
	REAR CONN PANEL2 ASSY	2115621-2	1	1	For 220V, CFM console (FRU501 includes FRU 502, 503, and 504 or 505) See Note below.	
502	CNTIF ASSY	2123327-2	1	2		6-2-62 
	CNTIF2 ASSY	2212958	1	2	Included in new Rear CONN Panel Assemblies, 2115619-2, 2115620-2, and 2115621-2	6-2-62 
503	AVIF ASSY	2123329	1	2	For CFM console	6-2-63 
	BVIF ASSY	2123601	1	2	For B/W console	6-2-63 
504	CIRCUIT PROTECTOR	U0043EK	1	1	For 115/100V console	6-2-64 
505	CIRCUIT PROTECTOR	U0026EK	1	1	For 220V console	6-2-64 

Note

New Rear CONN Panel2 Assy (2115619-2, 2115620-2, and 2115621-2) is released to support the Ethernet Connector for the DICOM connection. Old Rear CONN Panel Assy can be replaced with new one, respectively.

Note

The Rear CONN Panel Assemblies for B/W console (2138819, 2138820, and 2138821) are used only for the B/W console with the software version 3.40 or earlier.

OPERATOR CONSOLE ASSY

2127794 – 2127803	: V2.11
2164514 – 2164523	: V3.00
2180828 – 2180837	: V3.10
2212968 – 2212977	: V3.40
2239789, 2239793 – 2239799, 2239804, 2239805	: V4.01
2250251, 2250253 – 2250256, 2250258 – 2250267	: V4.31
2264467 – 2264472, 2264475, 2265935 – 2265941	: V5.01
2197064, 2198442 – 2198445	: LOGIQ™ 400CL, V3.20
2213911 – 2213915	: LOGIQ™ 400CL, V3.41
2239832 – 2239836	: LOGIQ™ 400CL, V4.02
2250270, 2250271, 2255918, 2255919	: LOGIQ™ 400CL, V4.32
2265944 – 2265947	: LOGIQ™ 400CL, V5.01

MATERIAL LIST (8/12) (continued)

FRU NO.	PART NAME	PART NO.	QTY.	FRU	DESCRIPTION	SECTION FOR REFERENCE
506	ECG BOARD ASSY	P9522WZ	1	1		6-2-65
	ECG BOARD2 ASSY	2207806	1	1	Old ECG Board Assy (P9522WZ) can be replaced with new ECG Board Assy (2207806)	6-2-65
	ECG BOARD2 ASSY	2207806-2	1	1	From V5 System	6-2-65
507	ECG PANEL ASSY	P9522XB	1	1		6-2-66
	ECG CONN PNL ASSY	2251836	1	1	From V5 System	6-2-66
508	ECG CABLE ASSY	P9509KG	1	2	For Japan includes P9509KC and KD	—
	ECG CABLE	P9509KC	1	2	System side	
	ECG CABLE	P9509KD	1	2	Patient side	
509	ECG CABLE ASSY	P9509KH	1	2	For USA, Europe and others includes P9509KE and KF	—
	ECG CABLE	P9509KE	1	2	System side	
	ECG CABLE	P9509KF	1	2	Patient side	

This page is left blank intentionally.

OPERATOR CONSOLE ASSY 8/12

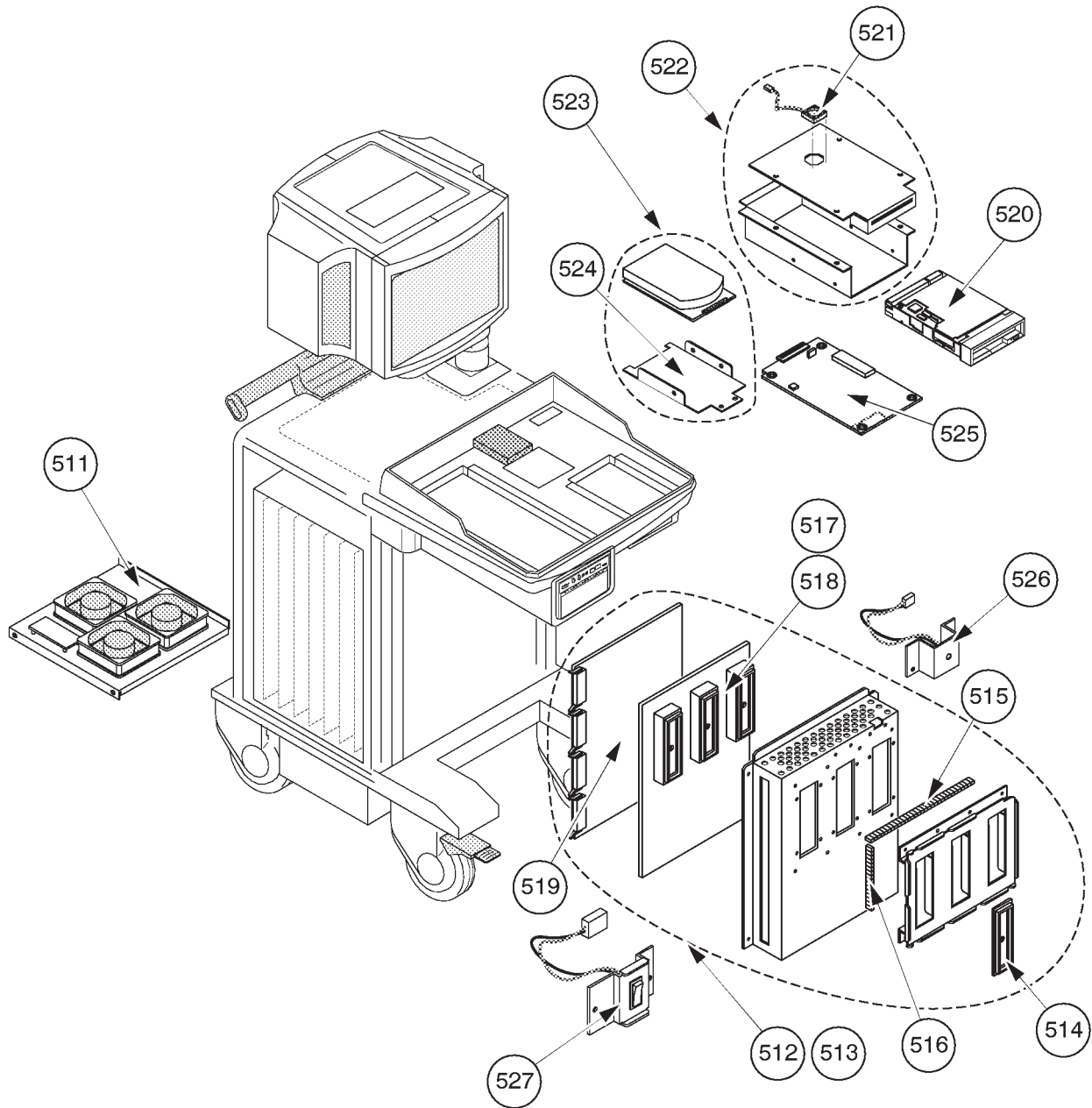

EXPLODED VIEW (g)
FRONT, UPPER & LEFT SIDE ACCESS
ILLUSTRATION 6-10

OPERATOR CONSOLE ASSY

2127794 – 2127803	: V2.11
2164514 – 2164523	: V3.00
2180828 – 2180837	: V3.10
2212968 – 2212977	: V3.40
2239789, 2239793 – 2239799, 2239804, 2239805	: V4.01
2250251, 2250253 – 2250256, 2250258 – 2250267	: V4.31
2264467 – 2264472, 2264475, 2265935 – 2265941	: V5.01
2197064, 2198442 – 2198445	: LOGIQ™ 400CL, V3.20
2213911 – 2213915	: LOGIQ™ 400CL, V3.41
2239832 – 2239836	: LOGIQ™ 400CL, V4.02
2250270, 2250271, 2255918, 2255919	: LOGIQ™ 400CL, V4.32
2265944 – 2265947	: LOGIQ™ 400CL, V5.01

MATERIAL LIST (8/12)

FRU NO.	PART NAME	PART NO.	QTY.	FRU	DESCRIPTION	SECTION FOR REFERENCE
	FRONT, UPPER & LEFT BLOCK					
511	NEST FAN ASSY	2117028	1	1		6-2-67
	NEST FAN ASSY	2265556	1	1	From V5 System	6-2-67
512	PROBE CONN SET ASSY	2128723	1	1	For 3 slots model	6-2-68
	PROBE CONN SET ASSY	2268527	1	1	From V5 System	6-2-68
513	PROBE CONN SET ASSY	2117027	1	1	For 2 slots model	6-2-68
	PROBE CONN SET ASSY	2117027-2	1	1	From software V3.00 console. This Assy has backward compatibility with old Assy (2117027)	6-2-68
	PROBE CONN SET ASSY	2265572	1	1	From V5 System	6-2-68
514	CONNECTOR COVER	U0477FD	1	2	blinds one slot for 2 slots models	6-2-69
515	SHIELD FINGER LONG	P9524DW	1	1		6-2-70
516	SHIELD FINGER SHORT	P9524DX	1	1		6-2-70
517	PROBE CONN 1 ASSY	2231575	1	2	For 3 slots model	6-2-71
518	DCON ASSY	2123321	1	2	For 2 slots model	6-2-71
519	PRAG ASSY	2123323	1	2		6-2-72
520	MODD	U0052ZA	1	1		6-2-73
	MODD	2187012	1	1	Refer to Note below:	6-2-73
	MODD	2187012-2	1	1	Refer to Note below:	6-2-73
521	MODD FAN	2122998-2	1	1		6-2-73
522	MODD HOLDER ASSY	2117029-2	1	2	including MODD Fan (521)	6-2-73

Note

The folding method of CB24A (or CB24N) cable is different between the case of using the old MODD (U0052ZA) and the case of using the new MODD (2187012 and 2187012-2). For more details regarding the folding cable, refer to 6-6-4.











Note

The appearance of new MODD (2187012-2) is different from the old one (2187012). The old MODD (2187012) can be replaced with new one (2187012-2). For the settings of the DIP switches and the jumper switches, refer to 6-2-73.

OPERATOR CONSOLE ASSY

2127794 – 2127803	: V2.11
2164514 – 2164523	: V3.00
2180828 – 2180837	: V3.10
2212968 – 2212977	: V3.40
2239789, 2239793 – 2239799, 2239804, 2239805	: V4.01
2250251, 2250253 – 2250256, 2250258 – 2250267	: V4.31
2264467 – 2264472, 2264475, 2265935 – 2265941	: V5.01
2197064, 2198442 – 2198445	: LOGIQ™ 400CL, V3.20
2213911 – 2213915	: LOGIQ™ 400CL, V3.41
2239832 – 2239836	: LOGIQ™ 400CL, V4.02
2250270, 2250271, 2255918, 2255919	: LOGIQ™ 400CL, V4.32
2265944 – 2265947	: LOGIQ™ 400CL, V5.01

MATERIAL LIST (8/12)

FRU NO.	PART NAME	PART NO.	QTY.	FRU	DESCRIPTION	SECTION FOR REFERENCE
	FRONT, UPPER & LEFT BLOCK					
523	V2.11y INIT'ED HDD KIT (3.5-INCH)	2146597-3	1	1	3.5-inch HDD which V/R 2.11y software is installed	6-2-75 
	V2.50y INIT'ED HDD KIT (3.5-INCH)	2179693-2	1	1	3.5-inch HDD which V/R 2.50y software is installed	6-2-75 
	V3.00Cy INIT'ED HDD KIT (3.5-INCH)	2164542-4	1	1	3.5-inch HDD which V/R 3.00 Cy software is installed	6-2-75 
	V3.10Cy INIT'ED HDD KIT (3.5-INCH)	2180324-4	1	1	3.5-inch HDD which V/R 3.10Cy software is installed	6-2-75 
	V3.20By INIT'ED HDD KIT (3.5-INCH)	2185221-4	1	1	3.5-inch HDD which V/R 3.20By software is installed For LOGIQ™ 400CL: 2197064, 2198442, 2198443, 2198444, and 2198445	6-2-75 
	V3.30By INIT'ED HDD KIT (3.5-INCH)	2208953-4	1	1	3.5-inch HDD which V/R 3.30By software is installed	6-2-75 
	V3.40Dy INIT'ED HDD KIT (3.5-INCH)	2219189-6	1	1	3.5-inch HDD which V/R 3.40Dy software is installed	6-2-75 
	V3.41Dy INIT'ED HDD KIT (3.5-INCH)	2219190-6	1	1	3.5-inch HDD which V/R 3.41Dy software is installed For LOGIQ™ 400CL: 2213911, 2213912, 2213913, 2213914, and 2213915	6-2-75 





Note

To replace the 2.5-inch HDD with the 3.5-inch HDD, use the HDD Replacement Kit (2160057) and the 3.5-inch HDD kit initialized with the appropriate software version. Make sure that the settings of DIP switches and jumper switches are set properly after replacing the HDD. The settings are different depending on the type of HDD.

OPERATOR CONSOLE ASSY

2127794 – 2127803	: V2.11
2164514 – 2164523	: V3.00
2180828 – 2180837	: V3.10
2212968 – 2212977	: V3.40
2239789, 2239793 – 2239799, 2239804, 2239805	: V4.01
2250251, 2250253 – 2250256, 2250258 – 2250267	: V4.31
2264467 – 2264472, 2264475, 2265935 – 2265941	: V5.01
2197064, 2198442 – 2198445	: LOGIQ™ 400CL, V3.20
2213911 – 2213915	: LOGIQ™ 400CL, V3.41
2239832 – 2239836	: LOGIQ™ 400CL, V4.02
2250270, 2250271, 2255918, 2255919	: LOGIQ™ 400CL, V4.32
2265944 – 2265947	: LOGIQ™ 400CL, V5.01

MATERIAL LIST (8/12) (continued)

FRU NO.	PART NAME	PART NO.	QTY.	FRU	DESCRIPTION	SECTION FOR REFERENCE
	FRONT, UPPER & LEFT BLOCK (CONTINUED)					
523	V4.01Cy INIT'ED HDD KIT (3.5-INCH)	2239423-4	1	1	3.5-inch HDD which V/R 4.01Cy software is installed	6-2-75 
	V4.02Cy INIT'ED HDD KIT (3.5-INCH)	2239426-4	1	1	3.5-inch HDD which V/R 4.02Cy software is installed For LOGIQ™ 400CL: 2239832, 2239833, 2239834, 2239835, and 2239836	6-2-75 
	V4.31By INIT'ED HDD KIT (3.5-INCH)	2248939-2	1	1	3.5-inch HDD which V/R 4.31B y software is installed	6-2-75 
	V4.32By INIT'ED HDD KIT (3.5-INCH)	2248942-2	1	1	3.5-inch HDD which V/R 4.32B y software is installed For LOGIQ™ 400CL: 2255918, 2255919, 2250271, and 2250270	6-2-75 
	V5.01y INT'ED HDD KIT	2264062	1	1	3.5-inch HDD which V/R 5.01y software is installed	6-2-75 

OPERATOR CONSOLE ASSY

2127794 – 2127803	: V2.11
2164514 – 2164523	: V3.00
2180828 – 2180837	: V3.10
2212968 – 2212977	: V3.40
2239789, 2239793 – 2239799, 2239804, 2239805	: V4.01
2250251, 2250253 – 2250256, 2250258 – 2250267	: V4.31
2264467 – 2264472, 2264475, 2265935 – 2265941	: V5.01
2197064, 2198442 – 2198445	: LOGIQ™ 400CL, V3.20
2213911 – 2213915	: LOGIQ™ 400CL, V3.41
2239832 – 2239836	: LOGIQ™ 400CL, V4.02
2250270, 2250271, 2255918, 2255919	: LOGIQ™ 400CL, V4.32
2265944 – 2265947	: LOGIQ™ 400CL, V5.01

MATERIAL LIST (8/12) (continued)

FRU NO.	PART NAME	PART NO.	QTY.	FRU	DESCRIPTION	SECTION FOR REFERENCE
524	HDD HOLDER ASSY	P9522WS	1	2		6-2-74
525	HDDB ASSY	P9525XU	1	1		6-2-75
526	HDD LED ASSY	P9522XN	1	2		6-2-76
527	POWER SWITCH ASSY	P9522WL	1	1		6-2-77
	POWER SWITCH ASSY	2251835	1	1	From V5 System	6-2-77
528	FLAT CABLE	P9522ME	1	1	CB21	—
529	FLAT CABLE	2126890	1	1	CB10A	—
530	FLAT CABLE	2126891	1	1	CB23A	—
531	FLAT CABLE	2126892	1	1	CB24A	—
532	FLAT CABLE	2126893	1	1	CB29A	—
533	FLAT CABLE	2126894	1	1	CB30A	—
534	CB6M CABLE	2122996	1	2	MODD – MOTHER	—
535	FLAT CABLE	2145889	1	1	CB24N for 3.5–inch HDD	—
536	HDD HOLDER2 ASSY	2145973	1	2	For 3.5–inch HDD	6-2-75
551	CB5 CABLE	P9522MC	1	2	2.5–inch HDD – Mother	—
552	CB45N CABLE	2145891	1	2	3.5–inch HDD – HDD LED Assy	—
553	CB46 CABLE	P9522NJ	1	2	HDDB Assy – HDD LED Assy	—
580	HDD REPLACEMENT KIT	2160057	1	2	Including required parts to replace 2.5–inch HDD with 3.5–inch HDD: HDD Holder2 Assy, three cables (CB24N, CB5N, and CB45N), Tie Wraps, and Instructions	6-6

Note

The console with the new type of 3.5–inch HDD (Quantum™ Fireball™ 1280S and Quantum™ Fireball™ EL) does not include the HDD LED Assy (P9525XU).

OPERATOR CONSOLE ASSY 9/12

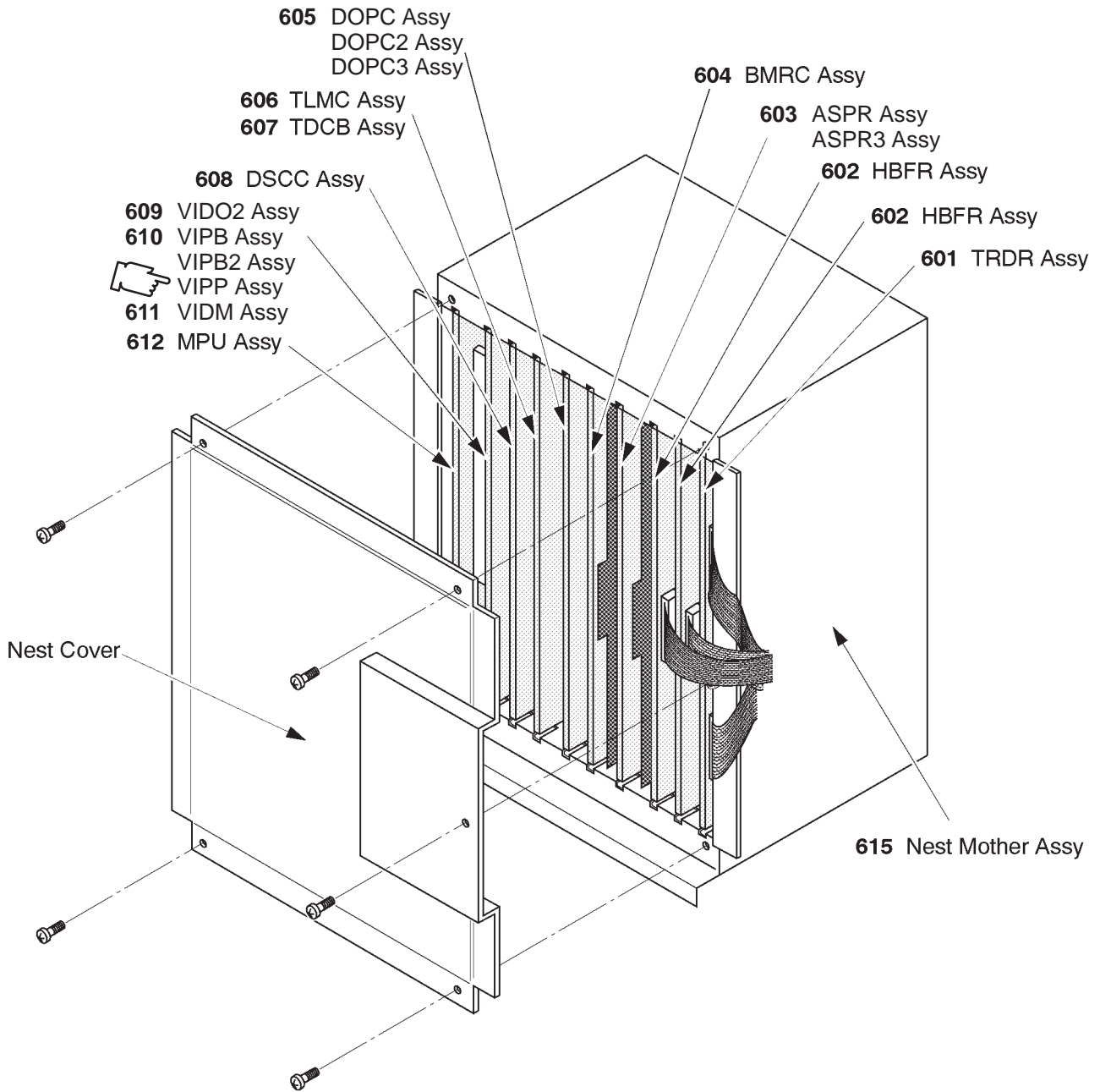







EXPLODED VIEW (h)
P. C. BOARDS
ILLUSTRATION 6-11

OPERATOR CONSOLE ASSY

2127794 – 2127803	: V2.11
2164514 – 2164523	: V3.00
2180828 – 2180837	: V3.10
2212968 – 2212977	: V3.40
2239789, 2239793 – 2239799, 2239804, 2239805	: V4.01
2250251, 2250253 – 2250256, 2250258 – 2250267	: V4.31
2264467 – 2264472, 2264475, 2265935 – 2265941	: V5.01
2197064, 2198442 – 2198445	: LOGIQ™ 400CL, V3.20
2213911 – 2213915	: LOGIQ™ 400CL, V3.41
2239832 – 2239836	: LOGIQ™ 400CL, V4.02
2250270, 2250271, 2255918, 2255919	: LOGIQ™ 400CL, V4.32
2265944 – 2265947	: LOGIQ™ 400CL, V5.01

MATERIAL LIST (9/12)

FRU NO.	PART NAME	PART NO.	QTY.	FRU	DESCRIPTION	SECTION FOR REFERENCE
	P. C. BOARDS					
601	TRDR ASSY	2123305	1	1		6-2-78 
	TRDR ASSY	2123305-2	1	1	From software version 3.00. Old TRDR (2123305) can be replaced with new TRDR (2123305-2)	6-2-78 
602	HBFR ASSY	2123307	1	1	This is one of 2 HBFR assemblies installed in a console	6-2-78 
603	ASPR ASSY	2123603	1	1		6-2-78 
	ASPR ASSY	2123603-2	1	1	From software version 3.00. Old ASPR (2123603) can be replaced with new ASPR (2123603-2)	6-2-78 
	ASPR3 ASSY	2192676	1	1	From software version 4.01 for MD and 4.02 for CL	6-2-78 
	ASPR3 ASSY	2192676-2	1	1	From software version 4.31 for MD, MR3 or 4.32 for CL. Old ASPR (2192676) can be replaced with new ASPR (2192676-2)	6-2-78 

Note

TRDR ASSY is changed with a backward compatibility from the console with software version 3.00. With this change, the part number of TRDR ASSY is changed to 2123305-2 from 2123305.

OPERATOR CONSOLE ASSY

2127794 – 2127803	: V2.11
2164514 – 2164523	: V3.00
2180828 – 2180837	: V3.10
2212968 – 2212977	: V3.40
2239789, 2239793 – 2239799, 2239804, 2239805	: V4.01
2250251, 2250253 – 2250256, 2250258 – 2250267	: V4.31
2264467 – 2264472, 2264475, 2265935 – 2265941	: V5.01
2197064, 2198442 – 2198445	: LOGIQ™ 400CL, V3.20
2213911 – 2213915	: LOGIQ™ 400CL, V3.41
2239832 – 2239836	: LOGIQ™ 400CL, V4.02
2250270, 2250271, 2255918, 2255919	: LOGIQ™ 400CL, V4.32
2265944 – 2265947	: LOGIQ™ 400CL, V5.01

MATERIAL LIST (9/12) (continued)

FRU NO.	PART NAME	PART NO.	QTY.	FRU	DESCRIPTION	SECTION FOR REFERENCE
604	BMRC ASSY	2123309	1	1		6-2-78
605	DOPC ASSY	2123311-2	1	1	only for color monitor model	6-2-78
	DOPC ASSY	2123311-3	1	1	From software version 3.00. Old DOPC(2123311-2) can be replaced with new DOPC (2123311-3)	6-2-78
	DOPC2 ASSY	2192564	1	1	From Software version 4.01 for MD and 4.02 for CL	6-2-78
	DOPC3 ASSY	2248949	1	1	From Software version 4.31 for MD, MR3 or 4.32 for CL	6-2-78
606	TLMC ASSY	2158390-2	1	1	For color monitor model, excluding OMEM. Old TLMC Assy (P9525WY and 2158390) can be replaced with new TLMC Assy (2158390-2)	6-2-78
607	TDCB ASSY	2123315-3	1	1	TDCB ASSY is used only for B&W monitor model. Old TDCB Assy (2123315 and 2123315-2) can be replaced with new TDCB Assy (2123315-3).	6-2-78









Note

TLMC ASSY is changed with a backward compatibility from the console with software version 3.00. TLMC ASSY (P9525WY and 2158390) can be replaced with the TLMC Assy (2158390-2).

OPERATOR CONSOLE ASSY

2127794 – 2127803	: V2.11
2164514 – 2164523	: V3.00
2180828 – 2180837	: V3.10
2212968 – 2212977	: V3.40
2239789, 2239793 – 2239799, 2239804, 2239805	: V4.01
2250251, 2250253 – 2250256, 2250258 – 2250267	: V4.31
2264467 – 2264472, 2264475, 2265935 – 2265941	: V5.01
2197064, 2198442 – 2198445	: LOGIQ™ 400CL, V3.20
2213911 – 2213915	: LOGIQ™ 400CL, V3.41
2239832 – 2239836	: LOGIQ™ 400CL, V4.02
2250270, 2250271, 2255918, 2255919	: LOGIQ™ 400CL, V4.32
2265944 – 2265947	: LOGIQ™ 400CL, V5.01

MATERIAL LIST (9/12) (continued)

FRU NO.	PART NAME	PART NO.	QTY.	FRU	DESCRIPTION	SECTION FOR REFERENCE
608	DSCC ASSY	2123313-2	1	1	DSCC	6-2-78 
	DSCC ASSY	2123313-3	1	1	DSCC ASSY is used only for color monitor model. Old DSCC (2123313-2) can be replaced with new DSCC (2123313-3).	6-2-78 
609	VIDO2 ASSY	2117032-2	1	1	For color monitor model without VTR playback	6-2-78 
	VIDO2 ASSY	2117032-3	1	1	For MVME147-010	6-2-78 
610	VIPB ASSY	P9525VA	1	1	For color monitor model with VTR playback	6-2-78 
	VIPB ASSY	2149141	1	1	For MVME147-010	6-2-78 
	VIPB2 ASSY	2212616	1	1	available only for console with software version 3.40B or later for MD console (3.41B or later for CL console)	6-2-78 
	VIPB2 ASSY	2212616-2	1	1	From software version 4.31 for MD, MR3 or 4.32 for CL. Old VIPB (2212616) can be replaced with new VIPB2 (2212616-2)	6-2-78 
	VIPP ASSY	2245652	1	1	available on console with software version 5.01 or later	6-2-78







Note

VIDO2 ASSY, VIPB ASSY and VIDM ASSY are changed with the backward compatibility to correspond to the new OBC ASSY, MVME147-010. With this changes, the part numbers of VIDO2 ASSY, VIPB ASSY and VIDM ASSY are changed to 2117032-3, 2149141 and 2123337-2 from 2117032-2, P9525VA and 2123337, respectively. Be sure to use the new Video board to replace the VIDO2 ASSY, VIPB ASSY or VIDM ASSY installed in the console with the MPU ASSY including the new OBC ASSY, MVME147-010.

OPERATOR CONSOLE ASSY

2127794 – 2127803	: V2.11
2164514 – 2164523	: V3.00
2180828 – 2180837	: V3.10
2212968 – 2212977	: V3.40
2239789, 2239793 – 2239799, 2239804, 2239805	: V4.01
2250251, 2250253 – 2250256, 2250258 – 2250267	: V4.31
2264467 – 2264472, 2264475, 2265935 – 2265941	: V5.01
2197064, 2198442 – 2198445	: LOGIQ™ 400CL, V3.20
2213911 – 2213915	: LOGIQ™ 400CL, V3.41
2239832 – 2239836	: LOGIQ™ 400CL, V4.02
2250270, 2250271, 2255918, 2255919	: LOGIQ™ 400CL, V4.32
2265944 – 2265947	: LOGIQ™ 400CL, V5.01







MATERIAL LIST (9/12) (continued)

FRU NO.	PART NAME	PART NO.	QTY.	FRU	DESCRIPTION	SECTION FOR REFERENCE
611	VIDM ASSY	2123337	1	1	For MVME147-SRF	6-2-78 
	VIDM ASSY	2123337-2	1	1	For MVME147-010	6-2-78 
	VIDM ASSY	2123337-3	1	1	For MVME147-010 Old VIDM (2123337-2) can be replaced with new VIDM (2123337-3)	6-2-78 
612	MPU ASSY	2123339-4	1	1	MASC Assy + ADPT Assy + OBC Assy Old MPU Assy (2123339, 2123339-2, and 2123339-3) can be replaced with new MPU Assy (2123339-4). This assy has to be installed to use VIPB2 Assy on B/W console with S/W V3.40 By.	6-2-77 
	MPU-A ASSY	2195746-3 	1	1	MASC Assy + ADPT2 Assy + OBC-A Assy (MVME167-002B + ROM) Old MPU-A Assy (2195746) can be replaced with new MPU-A Assy (2195746-3). This assy has to be installed to use VIPB2 Assy on B/W console with S/W V3.40By.	6-2-77 

OPERATOR CONSOLE ASSY

2127794 – 2127803	: V2.11
2164514 – 2164523	: V3.00
2180828 – 2180837	: V3.10
2212968 – 2212977	: V3.40
2239789, 2239793 – 2239799, 2239804, 2239805	: V4.01
2250251, 2250253 – 2250256, 2250258 – 2250267	: V4.31
2264467 – 2264472, 2264475, 2265935 – 2265941	: V5.01
2197064, 2198442 – 2198445	: LOGIQ™ 400CL, V3.20
2213911 – 2213915	: LOGIQ™ 400CL, V3.41
2239832 – 2239836	: LOGIQ™ 400CL, V4.02
2250270, 2250271, 2255918, 2255919	: LOGIQ™ 400CL, V4.32
2265944 – 2265947	: LOGIQ™ 400CL, V5.01

MATERIAL LIST (9/12) (continued)

FRU NO.	PART NAME	PART NO.	QTY.	FRU	DESCRIPTION	SECTION FOR REFERENCE
613	V2 TIME KEEPER RAM	2131692	1	1	For MVME147SRF	6-2-79 
613B	TIME KEEPER BATTERY	2143867	1	1	For MVME147-010	6-2-80 
613C	TIME KEEPER RAM	2195762	1	1	For MVME167-002B	6-2-81 
614	OMEM ASSY	P9525WU	1	1	Optional expansion Cine memory	6-2-82 
615	NEST MOTHER ASSY	2115627	1	1	Nest Box and Mother B'd	6-2-83 
	NEST MOTHER ASSY	2115627-2	1	1	From software V3.10 console. This Assy has backward compatibility with old Assy (2115627)	6-2-83 
616	MOTHER IC	P9522PK	1	1		6-2-84 

Note

There are two types of OBC (One Board Computer) ASSY (included in MPU ASSY), MVME147SRF and MVME147-010. Those two assemblies have functional compatibility. However, the type of time keeper RAM mounted on each board is different. In the case of MVME147SRF, the RAM with built-in back-up battery is used. On the other hand, RAM is soldered on the MVME147-010 and the battery is mounted on the RAM with a socket. Be sure to choose an appropriate one when replacing the time keeper RAM.

To know which OBC ASSY is installed in the console, check the 7-digit (or 9-digit) number displayed on the CRT monitor screen at the first of power-up sequence, 2136319 or 2136319-3 for MVME147SRF and 2136319-2 or 2136319-4 for MVME147-010.

OBC ASSY (included in MPU Assy)	MVME147SRF	MVME147-010
Time Keeper Battery Status	Built in the Time KeeperRAM	Use FRU 613B
Number displayed during power up sequence	2136319 or 2136319-3	2136319-2 or 2136319-4

■ OPERATOR CONSOLE ASSY 10/12

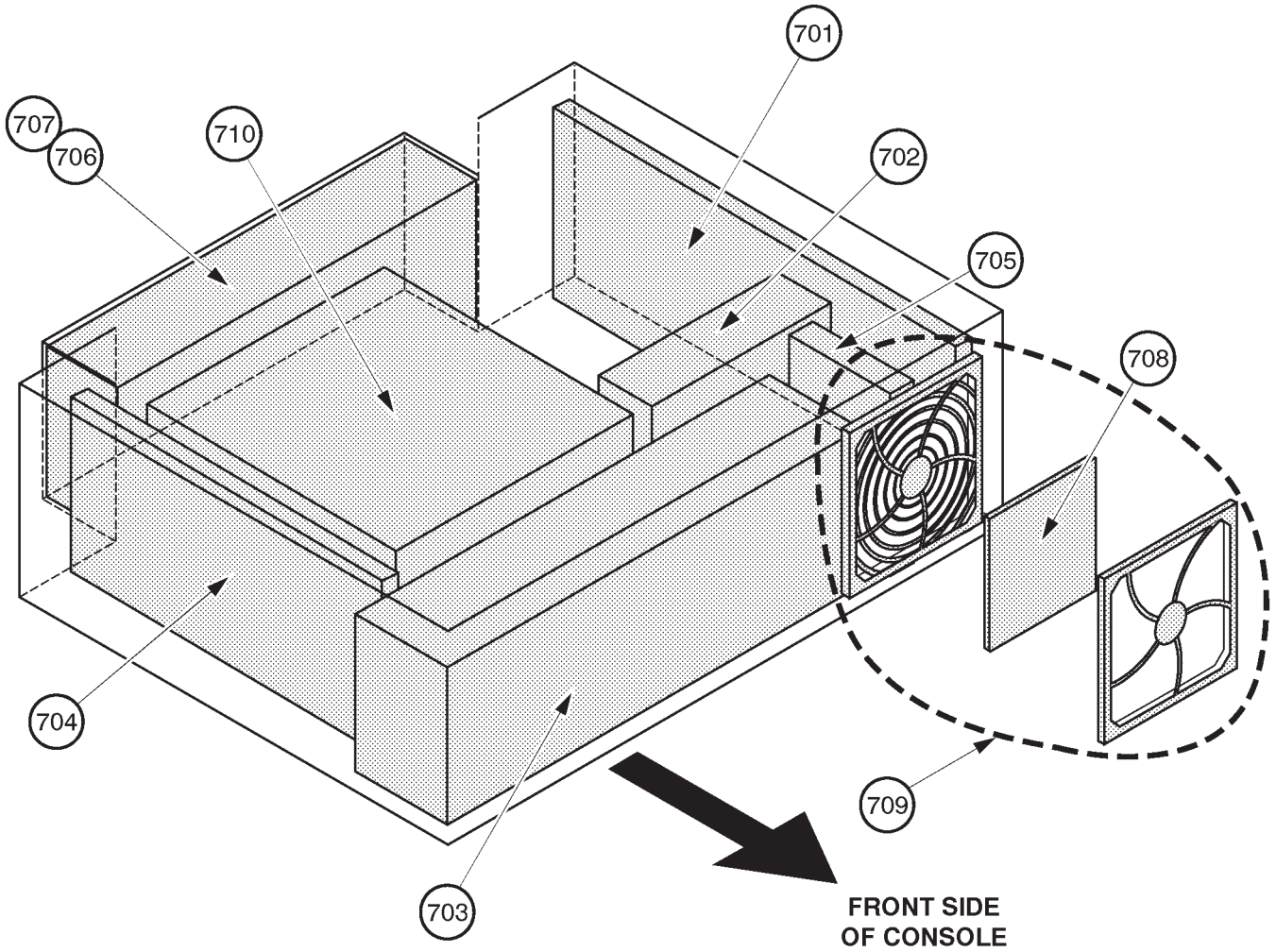









EXPLODED VIEW (i)
POWER SUPPLY UNIT
ILLUSTRATION 6-12

OPERATOR CONSOLE ASSY

2127794 – 2127803	: V2.11
2164514 – 2164523	: V3.00
2180828 – 2180837	: V3.10
2212968 – 2212977	: V3.40
2239789, 2239793 – 2239799, 2239804, 2239805	: V4.01
2250251, 2250253 – 2250256, 2250258 – 2250267	: V4.31
2264467 – 2264472, 2264475, 2265935 – 2265941	: V5.01
2197064, 2198442 – 2198445	: LOGIQ™ 400CL, V3.20
2213911 – 2213915	: LOGIQ™ 400CL, V3.41
2239832 – 2239836	: LOGIQ™ 400CL, V4.02
2250270, 2250271, 2255918, 2255919	: LOGIQ™ 400CL, V4.32
2265944 – 2265947	: LOGIQ™ 400CL, V5.01

MATERIAL LIST (10/12)

FRU NO.	PART NAME	PART NO.	QTY.	FRU	DESCRIPTION	SECTION FOR REFERENCE
	POWER SUPPLY BLOCK					
701	HIGH VOLTAGE ASSY	2126983-2	1	1		6-2-85 
702	HV FAN	2126990	1	1		6-2-86 
703	LOW VOLTAGE UNIT	2126989	1	1		6-2-87 
704	POWER CONTROL UNIT	2126984-3	1	1		6-2-88 
705	SSR UNIT	2126985	1	1		6-2-89 
706	POWER INLET UNIT 115/100V	2126987	1	1		6-2-90 
707	POWER INLET UNIT 220V	2126986	1	1		6-2-90 
708	PW AIR FILTER	2126992	1	1		6-2-91 
709	FILTER COVER SET	2126991	1	1	including Guard, Filter, and Retainer	6-2-92 
710	POWER TRANSFORMER	2126988	1	2		—
711	115V POWER SUPPLY UNIT	2126982	1	2		6-5
712	220V POWER SUPPLY UNIT	2126981	1	2		6-5

■ OPERATOR CONSOLE ASSY 12/12

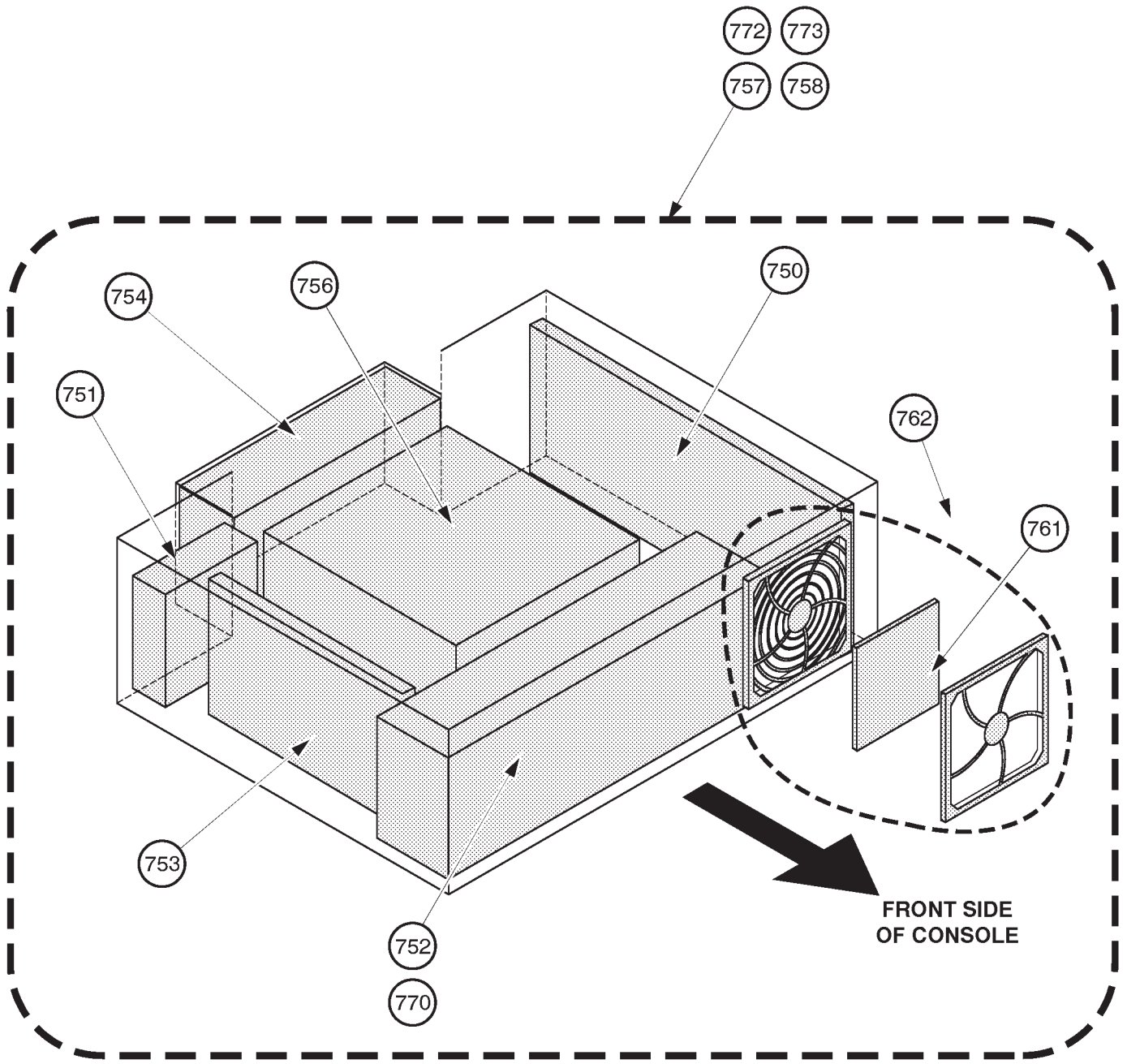









EXPLODED VIEW (j)
POWER SUPPLY UNIT2
ILLUSTRATION 6-13

OPERATOR CONSOLE ASSY

2127794 – 2127803	: V2.11
2164514 – 2164523	: V3.00
2180828 – 2180837	: V3.10
2212968 – 2212977	: V3.40
2239789, 2239793 – 2239799, 2239804, 2239805	: V4.01
2250251, 2250253 – 2250256, 2250258 – 2250267	: V4.31
2264467 – 2264472, 2264475, 2265935 – 2265941	: V5.01
2197064, 2198442 – 2198445	: LOGIQ™ 400CL, V3.20
2213911 – 2213915	: LOGIQ™ 400CL, V3.41
2239832 – 2239836	: LOGIQ™ 400CL, V4.02
2250270, 2250271, 2255918, 2255919	: LOGIQ™ 400CL, V4.32
2265944 – 2265947	: LOGIQ™ 400CL, V5.01

MATERIAL LIST (12/12)

FRU NO.	PART NAME	PART NO.	QTY.	FRU	DESCRIPTION	SECTION FOR REFERENCE
	POWER SUPPLY BLOCK 2					
750	HV UNIT	2144488-2	1	1		6-2-93 
751	COOLING FAN	2158762	1	1		6-2-94 
752	LV2 UNIT	2144482-6	1	1		6-2-95 
753	TRIAC UNIT	2144487	1	1		6-2-96 
754	POWER INLET UNIT2 115/100V	2144485	1	1		6-2-97 
755	POWER INLET UNIT2 220V	2144484	1	1		6-2-97 
756	POWER TRANSFORMER 2	2144483	1	2		—
757	115V POWER SUPPLY UNIT2	2144481	1	2		6-5
758	220V POWER SUPPLY UNIT2	2144480	1	2		6-5
761	PW AIR FILTER	2126992	1	1	Same as FRU 708	6-2-91 
762	FILTER COVER SET	2126991	1	1	Same as FRU 709 Including Guard, Filter, and Retainer.	6-2-92 
770	LV3 UNIT	2211491	1	1	GE01 including CN31 cable and PN label. LV2 Unit (2144482-6) can be replaced with LV3 Unit. Refer to 6-7 on page 6-276.	6-2-98 
772	115V POWER SUPPLY UNIT3	2212638	1	2		6-5
773	220V POWER SUPPLY UNIT3	2212637	1	2		6-5

OPERATOR CONSOLE ASSY

2127794 – 2127803	: V2.11
2164514 – 2164523	: V3.00
2180828 – 2180837	: V3.10
2212968 – 2212977	: V3.40
2239789, 2239793 – 2239799, 2239804, 2239805	: V4.01
2250251, 2250253 – 2250256, 2250258 – 2250267	: V4.31
2264467 – 2264472, 2264475, 2265935 – 2265941	: V5.01
2197064, 2198442 – 2198445	: LOGIQ™ 400CL, V3.20
2213911 – 2213915	: LOGIQ™ 400CL, V3.41
2239832 – 2239836	: LOGIQ™ 400CL, V4.02
2250270, 2250271, 2255918, 2255919	: LOGIQ™ 400CL, V4.32
2265944 – 2265947	: LOGIQ™ 400CL, V5.01

MATERIAL LIST (12/12) (continued)

FRU NO.	PART NAME	PART NO.	QTY.	FRU	DESCRIPTION	SECTION FOR REFERENCE
	OTHERS					
801	FUSE SET	2135619	1	1	For Power Supply Unit	6-3
801B	FUSE SET 2	2144490	1	1	For Power Supply Unit 2	6-3
802	SCREW SET	P9523NW	1	1		
901	PROBE ADAPTER TYPE PA51	2136306	1	1	For Japan	—
	PROBE ADAPTER TYPE PA51	2136307	1	1	For USA/Europe/Asia	—
902	PROBE ADAPTER TYPE 5S	P9602AN	1	1	For Japan	—
	PROBE ADAPTER TYPE 5S	P9602AT	1	1	For USA/Europe/Asia	—
904	V2.11 SOFTWARE MO DISK SET	2136320-4	1	2	V2.11 y	
913	V2.50 SOFTWARE MO DISK SET	2171909-2	1	2	V2.50 y	—
905	V3.00 SOFTWARE MO DISK SET	2164543-4	1	2	V3.00 Cy	—
906	V3.10 SOFTWARE MO DISK SET	2180336-4	1	2	V3.10 Cy	—
907	V3.20 SOFTWARE MO DISK SET	2185220-4	1	2	For LOGIQ™ 400CL V3.20 By: 2197064, 2198442, 2198443, 2198444, and 2198445	—
908	V3.30 SYSTEM MO DISK	2208950-4	1	2	V3.30 By	—
909	V3.40 SYSTEM MO DISK	2219191-6	1	2	V3.40 Dy	—
912	V3.41 SYSTEM MO DISK	2219192-6	1	2	For LOGIQ™ 400CL V3.41 Dy: 2213911, 2213912, 2213913, 2213914, and 2213915	—
913	V4.01 SYSTEM MO DISK	2239421-4	1	2	V4.01 Cy	—
914	V4.02 SYSTEM MO DISK	2239424-4	1	2	For LOGIQ™ 400CL V4.02 Cy: 2239832, 2239833, 2239834, 2239835, and 2239836	—

OPERATOR CONSOLE ASSY

2127794 – 2127803	: V2.11
2164514 – 2164523	: V3.00
2180828 – 2180837	: V3.10
2212968 – 2212977	: V3.40
2239789, 2239793 – 2239799, 2239804, 2239805	: V4.01
2250251, 2250253 – 2250256, 2250258 – 2250267	: V4.31
2264467 – 2264472, 2264475, 2265935 – 2265941	: V5.01
2197064, 2198442 – 2198445	: LOGIQ™ 400CL, V3.20
2213911 – 2213915	: LOGIQ™ 400CL, V3.41
2239832 – 2239836	: LOGIQ™ 400CL, V4.02
2250270, 2250271, 2255918, 2255919	: LOGIQ™ 400CL, V4.32
2265944 – 2265947	: LOGIQ™ 400CL, V5.01

MATERIAL LIST (12/12) (continued)

FRU NO.	PART NAME	PART NO.	QTY.	FRU	DESCRIPTION	SECTION FOR REFERENCE
	OTHERS (Continued)					
954	LH PROBE	P9601AS	1	1	For USA/Europe/Asia	—
	LH PROBE	P9601AC	1	1	For Japan	—
955	W PROBE	P9600BH	1	1	For USA/Europe/Asia	—
	W PROBE	P9600BD	1	1	For Japan	—
956	C364 PROBE	P9607AB	1	1	For USA/Europe/Asia	—
	C364 PROBE	P9607AA	1	1	For Japan	—
957	C551 PROBE	P9607AD	1	1	For USA/Europe/Asia	—
	C551 PROBE	P9607AC	1	1	For Japan	—
958	E721 PROBE	P9607AF	1	1	For USA/Europe/Asia	—
	E721 PROBE	P9607AE	1	1	For Japan	—
959	739L PROBE	2107460–2	1	1	For USA/Europe/Asia	—
	739L PROBE	2107460	1	1	For Japan	—
961	L764 PROBE	2121377–2	1	1	For USA/Europe/Asia	—
962	C721 PROBE	2121267–2	1	1	For USA/Europe/Asia	—
964	S220 PROBE	2121793–2	1	1	For USA/Europe/Asia	—
	S220 PROBE	2121793	1	1	For Japan	—
973	546L PROBE	2144266–2	1	1	For USA/Europe/Asia	—
	546L PROBE	2144266	1	1	For Japan	—
974	S317 PROBE	2144268–2	1	1	For USA/Europe/Asia	—
	S317 PROBE	2144268	1	1	For Japan	—
975	S611 PROBE	2144267–2	1	1	For USA/Europe/Asia	—
	S611 PROBE	2144267	1	1	For Japan	—

OPERATOR CONSOLE ASSY

2127794 – 2127803	: V2.11
2164514 – 2164523	: V3.00
2180828 – 2180837	: V3.10
2212968 – 2212977	: V3.40
2239789, 2239793 – 2239799, 2239804, 2239805	: V4.01
2250251, 2250253 – 2250256, 2250258 – 2250267	: V4.31
2264467 – 2264472, 2264475, 2265935 – 2265941	: V5.01
2197064, 2198442 – 2198445	: LOGIQ™ 400CL, V3.20
2213911 – 2213915	: LOGIQ™ 400CL, V3.41
2239832 – 2239836	: LOGIQ™ 400CL, V4.02
2250270, 2250271, 2255918, 2255919	: LOGIQ™ 400CL, V4.32
2265944 – 2265947	: LOGIQ™ 400CL, V5.01

MATERIAL LIST (12/12) (continued)

FRU NO.	PART NAME	PART NO.	QTY.	FRU	DESCRIPTION	SECTION FOR REFERENCE
	OTHERS (Continued)					
976	C386 PROBE	2154186-2	1	1	For USA/Europe/Asia	—
	C386 PROBE	2154186	1	1	For Japan	—
977	I739 PROBE	2147189-2	1	1	For USA/Europe/Asia	—
	I739 PROBE	2147189	1	1	For Japan	—
978	T739 PROBE	2147188-2	1	1	For USA/Europe/Asia	—
	T739 PROBE	2147188	1	1	For Japan	—
980	LA39 PROBE	2155078-2	1	1	For USA/Europe/Asia	—
	LA39 PROBE	2155078	1	1	For Japan	—
981	B510 PROBE	2123593	1	1	For USA/Europe/Asia	—
	B510 PROBE	2133115	1	1	For Japan	—
982	S222 PROBE	2159263	1	1	For USA/Europe/Asia	—
	S222 PROBE	2156263	1	1	For Japan	—
983	CWD2 PROBE	2123594	1	1	For USA/Europe/Asia	—
	CWD2 PROBE	2133116	1	1	For Japan	—
984	CWD5 PROBE	2123595	1	1	For USA/Europe/Asia	—
	CWD5 PROBE	2133117	1	1	For Japan	—
985	LD PROBE	P9601AD	1	1	For Japan	—
986	C358 PROBE	2193617	1	1	For USA/Europw/Asia	—
	C358 PROBE	2172443	1	1	For Japan	—
987	ERB7 PROBE	2239590	1	1	For USA/Europe/Asia	—
	ERB7 PROBE	2204232	1	1	For Japan	—
988	3S PROBE	2252157	1	1	For USA/Europe/Asia	—

This page is left blank intentionally.

6-2 DISASSEMBLY/RE-ASSEMBLY**WARNING!**

ONLY QUALIFIED SERVICE PERSONNEL SHOULD REMOVE ANY COVERS OR PANELS. ELECTRICAL HAZARDS EXISTS AT SEVERAL POINTS INSIDE. BECOME THOROUGHLY FAMILIAR WITH ALL HAZARDOUS VOLTAGES AND HIGH CURRENT LEVELS TO AVOID ACCIDENTAL CONTACT

CAUTION

Do not wear the ESD wrist strap when you remove a part of power supply unit. Turn OFF power and unplug the power cord before removing a part of power supply unit. However be sure to turn off power and wear the strap before you remove a circuit boards.

6–2–1 Monitor Assy (FRU No. 100)**Time Required**

0.25 Hours

Tool Required

Screwdriver

Hexagonal Wrench

Procedure**WARNING!**

PERSONAL INJURY HAZARD. THE NECK ASSY IS SPRING LOADED. RELEASING ARM WHEN MONITOR IS NOT INSTALLED WILL CAUSE SUDDEN UPWARD MOVEMENT. KEEP YOUR HEAD AND BODY AWAY FROM ABOVE NECK ASSY.

- Refer to ILLUSTRATION 6–14.
- 1. Turn OFF the system.
- 2. Remove the CRT Filter. Refer to 6–2–6 on page 6–79.
- 3. Unscrew four hexagonal screws (① – ④) located beneath the horizontal part of the Neck Assy.
- 4. Remove the cover located at the bottom of the Neck Assy.
- 5. Unscrew two screws (⑤ and ⑥) and remove the plate fixing the cables.
- 6. Disconnect the four connectors (⑦ –⑩).
- 7. Remove the screw cap located at position (⑪).
- 8. Loosen one screw (⑪) and pull the Monitor Assy upwards.

Note

When replacing the monitor with the new Monitor Assy (2162081), be sure to attach the proper label included with the Monitor Assy on to the Escutcheon. To attach the new label, refer to the procedures in section 6–2–2 on page 6–72.

Note

The color of the Escutcheon for LOGIQ™ 400CL is different from the other color monitor assy. Use the proper FRU when replacing the monitor assy for the LOGIQ™ 400CL.

6-2-1 Monitor Assy (FRU No. 100) (continued)

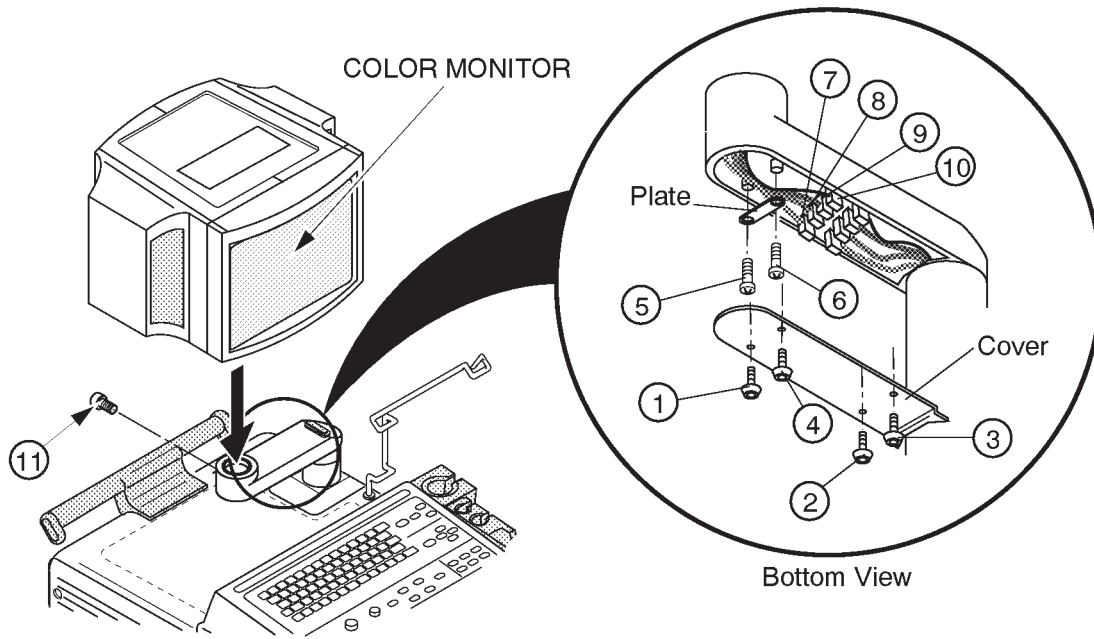

MONITOR ASSY DISASSEMBLY
ILLUSTRATION 6-14



6–2–2 Monitor Cover Set (FRU No. 101)**Time Required**

20 Minutes

Tool Required

Screwdriver

Procedure

■ Refer to ILLUSTRATION 6–15 on page 6–73.

1. Turn OFF the system.
2. Unscrew three screws (① – ③).
3. Remove the Monitor Cover L Assy (FRU 104).
4. Unscrew three screws (④ – ⑥).
5. Remove the Monitor Cover R Assy (FRU 105).
6. Remove the Monitor Cover Top Assy (FRU 106).
7. Push and open the Escutcheon Front Door (FRU 107).
8. Pull the two caps (⑦), FRU 108: CRT Cap Set) out.
9. Loosen four screws (⑧ – ⑪).
10. Disconnect one connector of task lamp switch.
11. Remove the Escutcheon Assy (FRU 102).

Note

Monitor Cover Set (FRU 101) includes the Escutcheon Assy (FRU 102), Escutcheon Latch (FRU 103), Monitor Cover L Assy (FRU 104), Monitor Cover R Assy (FRU 105), Monitor Cover Top Assy (FRU 106), and the Escutcheon Front Door (FRU 107).

Note

When replacing the Escutcheon with the new Monitor Cover Set (2162082) or replacing the Escutcheon Assy (2162083), be sure to attach the proper label on the Escutcheon. To attach the new label, refer to the procedures described in the following pages.

Note

The color of the Escutcheon for the LOGIQ™ 400CL is different from the other color monitor assy. Use the proper FRU when replacing the monitor cover set for the LOGIQ™ 400CL.

6-2-2 Monitor Cover Set (FRU No. 101) (continued)

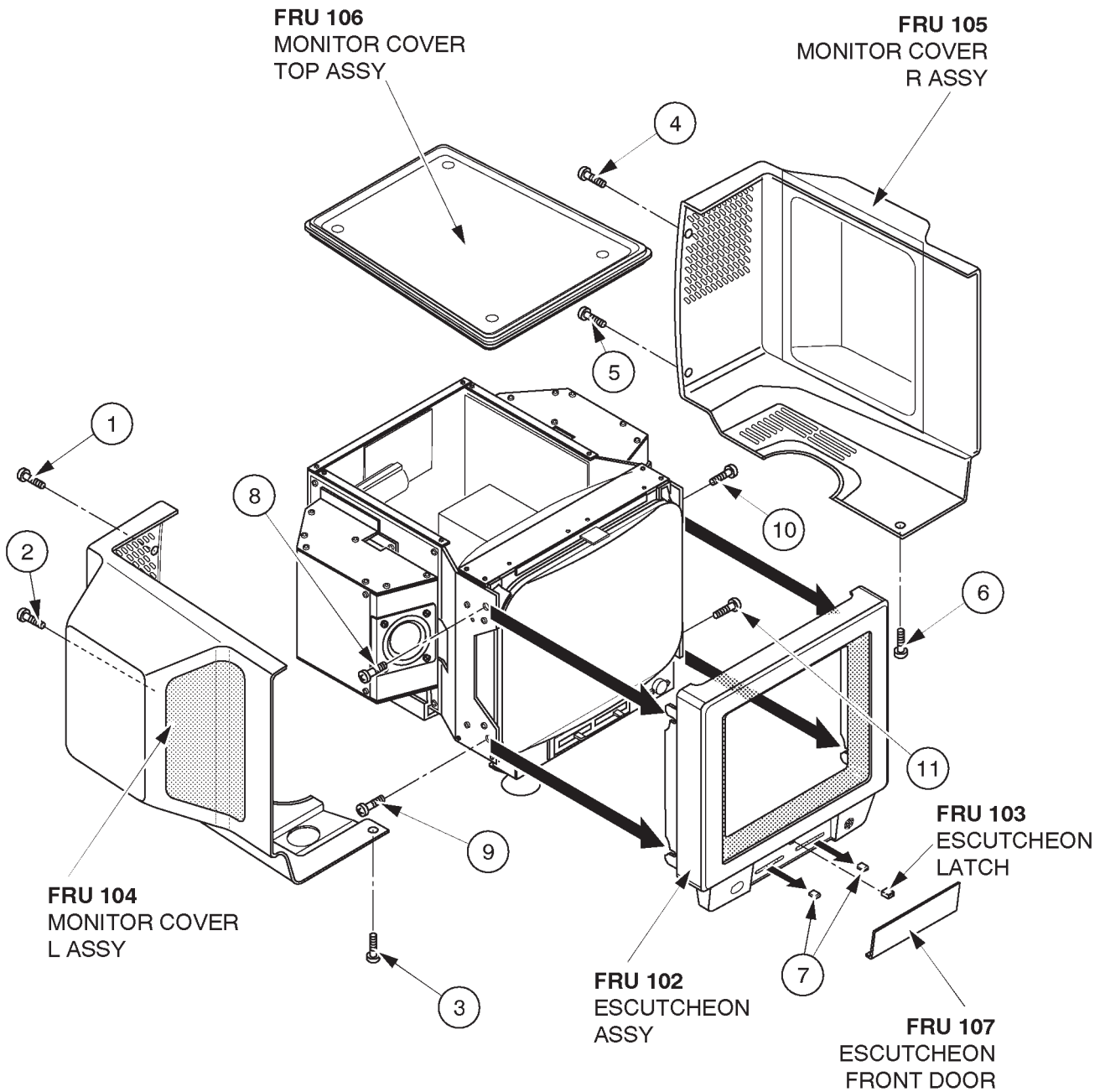

MONITOR COVER SET DISASSEMBLY
ILLUSTRATION 6-15

6-2-2 Monitor Cover Set (FRU No. 101) (continued)

Note

The new Monitor Cover Set (2162082) and Escutcheon Assy (2162083) include the four different labels for the Escutcheon. When replacing the Escutcheon with the new Monitor Cover Set or replacing the Escutcheon Assy, be sure to attach the proper label on the Escutcheon as follows:

- a. Choose the proper label, "LOGIQ 400" or "LOGIQ 400 MD" indicating the same model name as the label on the removed Escutcheon.
- b. Remove the lower pasteboard from the proper label. Refer to ILLUSTRATION 6-16.

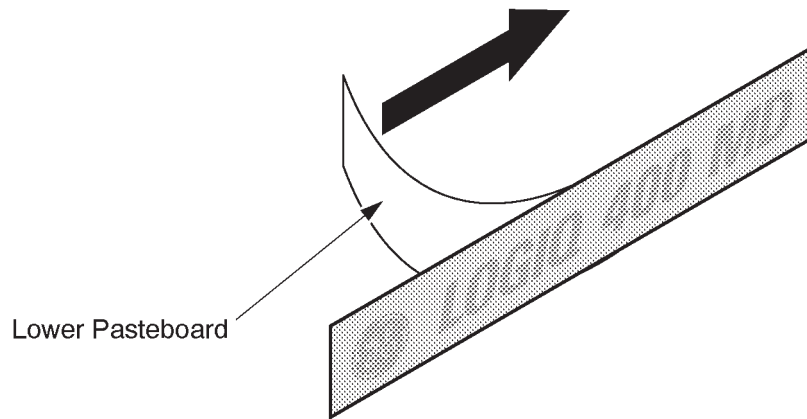

Lower Pasteboard

REMOVING LOWER PASTEBOARD
ILLUSTRATION 6-16

- c. Set and attach the label on the Escutcheon. Adjust the position of the label attached as shown in ILLUSTRATION 6-17. Be careful not to attach the label with a misalignment.

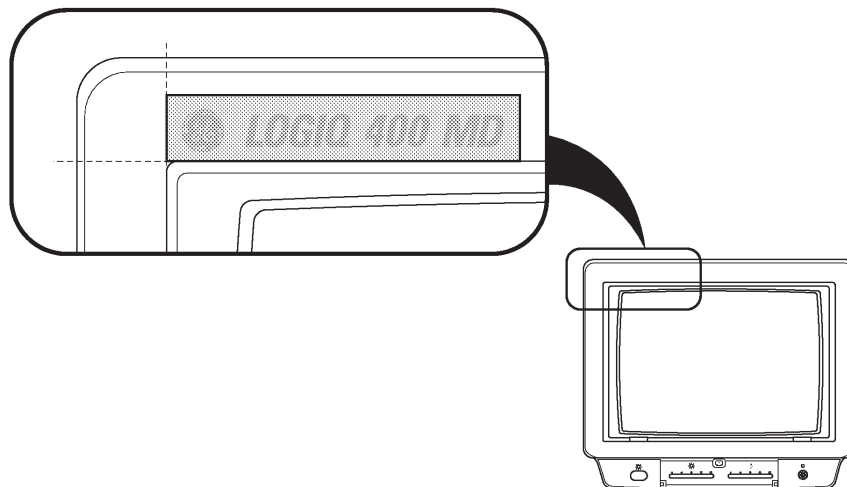

ATTACHING LABEL
ILLUSTRATION 6-17

6-2-2 Monitor Cover Set (FRU No. 101) (continued)

d. Press down the label all around.

e. Remove the upper pasteboard from the label. refer to ILLUSTRATION 6-18.

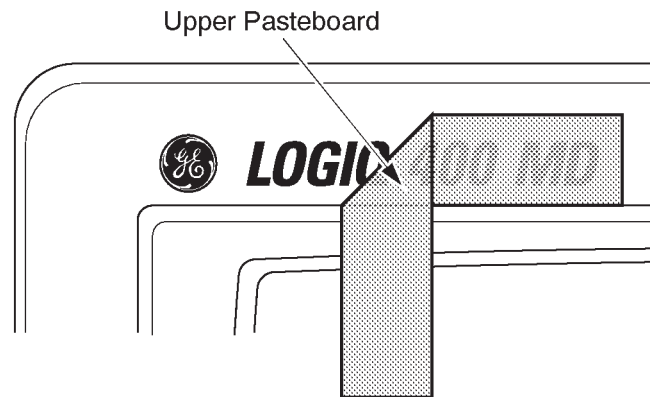

REMOVING UPPER PASTEBOARD

ILLUSTRATION 6-18

6-2-3 Escutcheon Latch (FRU No. 103)**Time Required**

10 Minute

Tool Required

Screwdriver

Procedure

- Refer to ILLUSTRATION 6-19.
- 1. Turn OFF the system.
- 2. Remove the Escutcheon Assy (FRU 102). Refer to 6-2-2 on page 6-72.
- 3. Remove the Escutcheon Latch (FRU 103) from the Escutcheon Assy (FRU 102) as shown in ILLUSTRATION 6-19.
-

**ESCUTCHEON LATCH REMOVAL**

ILLUSTRATION 6-19

6-2-4 Escutcheon Front Door (FRU No. 107)**Time Required**

1 Minute

Tool Required

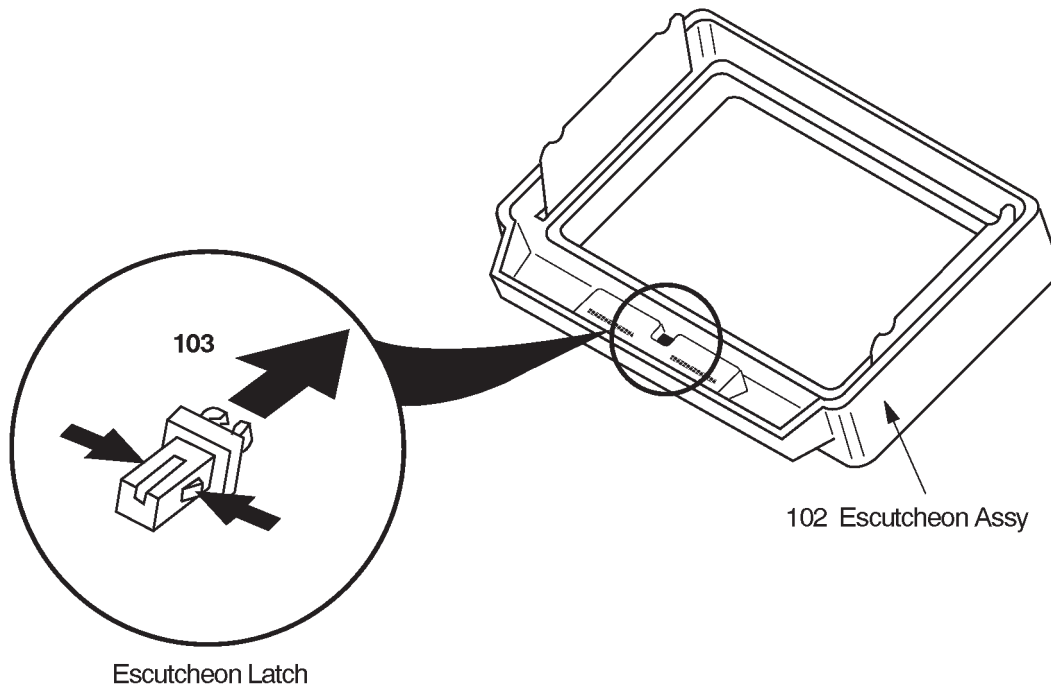
Not necessary

Procedure

- Refer to ILLUSTRATION 6-20.

1. Turn OFF the system.
2. Pull out the Escutcheon Front Door (FRU 107) from the Escutcheon Assy (FRU 102) as shown in ILLUSTRATION 6-20.

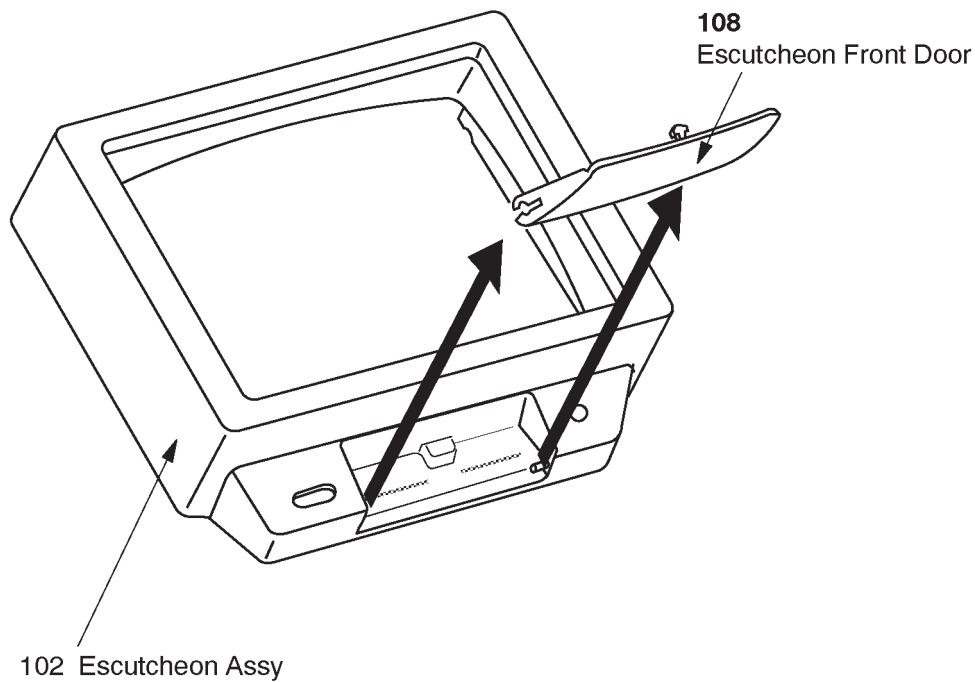

ESCUTCHEON FRONT DOOR REMOVAL
ILLUSTRATION 6-20

Note

The color of the Escutcheon for the LOGIQ™ 400CL is different from the other color monitor assy. Use the proper FRU when replacing the monitor cover set for the LOGIQ™ 400CL.

6-2-5 CRT Cap Set (FRU No. 108)**Time Required**

1 Minute

Tool Required

Not necessary

Procedure

- Refer to ILLUSTRATION 6-21.
- 1. Turn OFF the system.
- 2. Remove the Escutcheon Front Door (FRU 107). Refer to 6-2-4 on page 6-77.
- 3. Pull out two CRT Caps from the front side of the Monitor Assy.

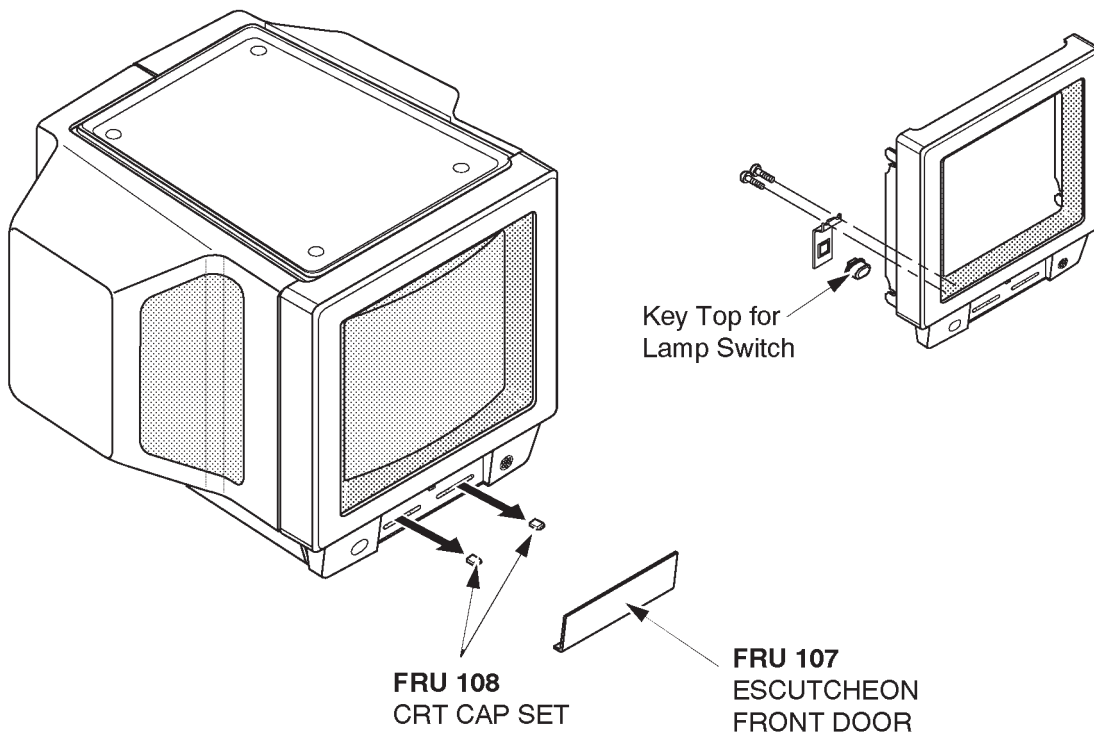

CRT CAP SET REMOVAL
ILLUSTRATION 6-21

Note

The CRT Cap Set (FRU108) includes the key top of lamp switch.

6-2-6 CRT Filter (FRU No. 109), CRT Filter Clamp Set (FRU No. 110)**Time Required**

1 Minutes

Tool Required

Not necessary

Procedure

■ Refer to ILLUSTRATION 6-22.

1. Turn OFF the system.
2. Slide the left side filter clamp leftwards and pull it out.
3. Slide the right side filter clamp rightwards and pull it out.
4. Remove the CRT Filter.

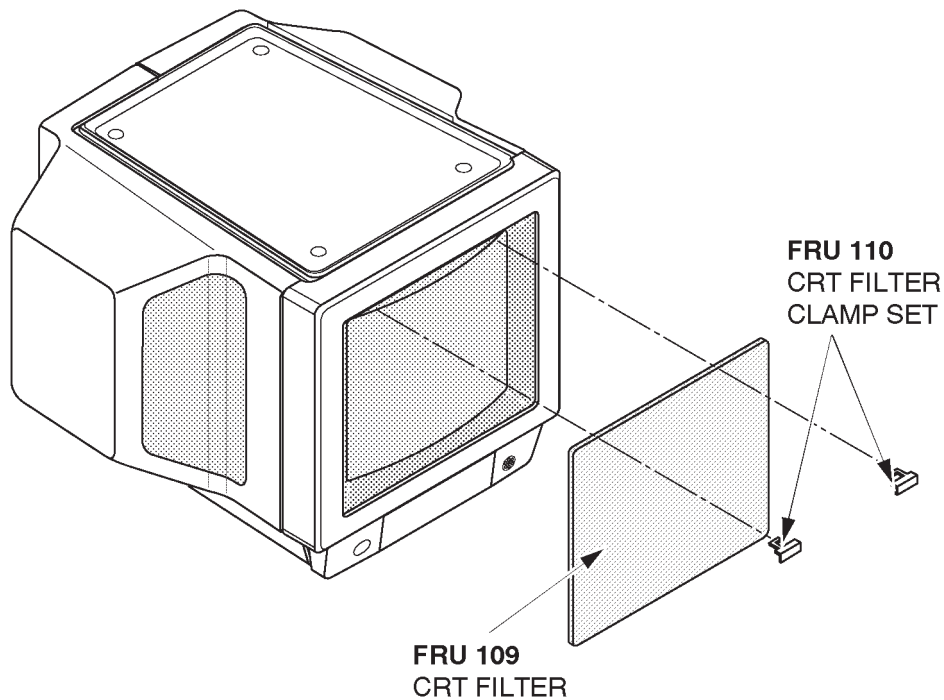

■
CRT FILTER REMOVAL
ILLUSTRATION 6-22

Note

The CRT Filter (FRU109) includes the CRT Filter Clamps (FRU110).

6-2-7 Accessory Assy (FRU No. 111)**Time Required**

0.5 Hours

Tool Required

Screwdriver

Procedure

- Refer to ILLUSTRATION 6-23.
- 1. Turn OFF the system.
- 2. Remove the Monitor Cover Set (FRU 101). Refer to 6-2-2 on page 6-72.
- 3. Unscrew five screws (① – ⑤).
- 4. Disconnect two connectors (⑥ and ⑦).
- 5. Remove the Accessory Assy.

**ACCESSORY ASSY DISASSEMBLY**

ILLUSTRATION 6-23

This page is left blank intentionally.

6-2-8 Speaker Assy (FRU No. 112)**Time Required**

0.5 Hours

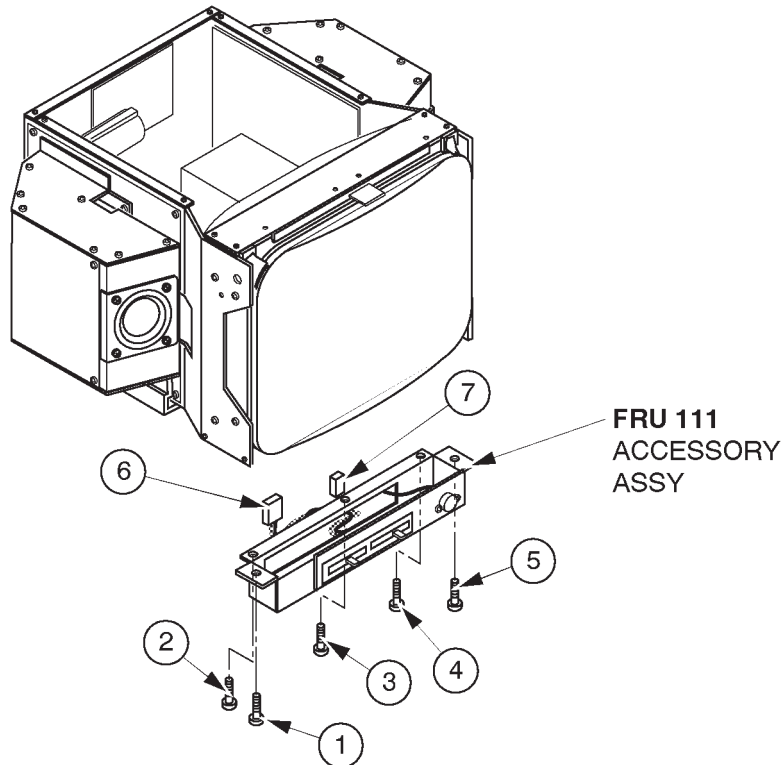
Tool Required

Screwdriver

Procedure

- Refer to ILLUSTRATION 6-24 on page 6-83.
- 1. Turn OFF the system.
- 2. Remove the Monitor Cover L Assy (FRU 104) and Monitor Cover R Assy (FRU 105). Refer to 6-2-2 on page 6-72.
-
- 3. Cut off the tie wrap fixing the CRT Cable Set (FRU 116) to the speaker.
- 4. Unscrew two screws (① and ②).
- 5. Loosen two screws (③ and ④).
- 6. Disconnect one connector (⑤) from the back side of monitor.
- 7. Remove the speaker at the left.
- 8. Unscrew two screws (⑥ and ⑦).
- 9. Loosen two screws (⑧ and ⑨).
- 10. Disconnect one connector (⑩) from the back side of monitor.
- 11. Remove the speaker at the right.

6-2-8 Speaker Assy (FRU No. 112) (continued)

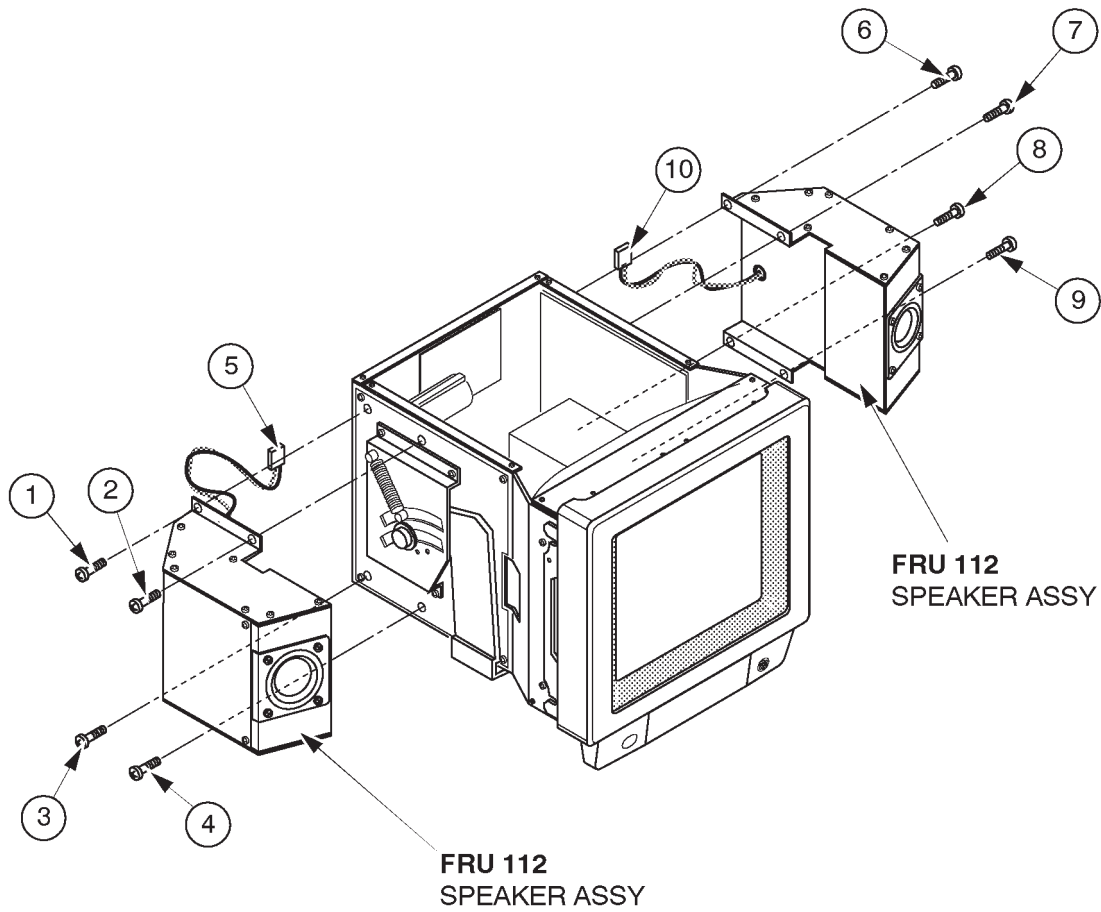

SPEAKER ASSY DISASSEMBLY
ILLUSTRATION 6-24

Note

Left and right speakers are interchangeable.

6-2-9 CRT Lamp Assy (FRU No. 113), CRT Lamp (FRU No. 114)**Time Required**

0.5 Hours

Tool Required

Screwdriver

Procedure

- Refer to ILLUSTRATION 6-25.
- 1. Turn OFF the system.
- 2. Remove the Monitor Cover L Assy (FRU 104) and Monitor Cover R Assy (FRU 105). Refer to 6-2-2 on page 6-72.
- 3. Turn the CRT lamp counterclockwise and remove it.
- 4. Unscrew two screws (① and ②).
- 5. Disconnect one connector (③).
- 6. Remove the CRT Lamp Assy.

**CRT LAMP ASSY DISASSEMBLY**

ILLUSTRATION 6-25

This page is left blank intentionally.

6-2-10 CRT Assy (FRU No. 115)**Time Required**

0.5 Hours

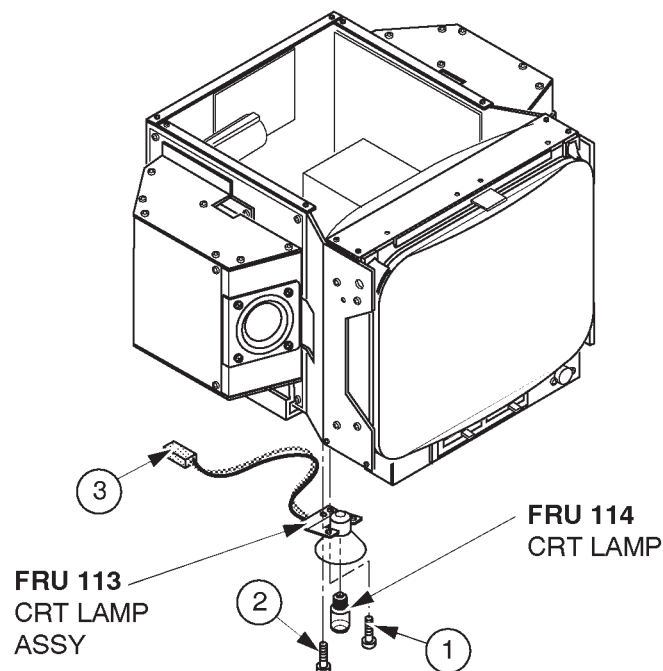
Tool Required

Screwdriver

Hexagonal Wrench

Procedure

PERSONAL INJURY HAZARD. THE NECK ASSY IS SPRING LOADED. RELEASING ARM WHEN MONITOR IS NOT INSTALLED WILL CAUSE SUDDEN UPWARD MOVEMENT. KEEP YOUR HEAD AND BODY AWAY FROM ABOVE NECK ASSY.

- Refer to ILLUSTRATION 6-26 on page 6-87.
- 1. Turn OFF the system.
- 2. Remove the Monitor Assy (FRU 100). Refer to 6-2-1 on page 6-70.
- 3. Remove the Monitor Cover Set (①): FRU 101). Refer to 6-2-2 on page 6-72.
- 4. Remove the Speaker Assy (②): FRU 112). Refer to 6-2-8 on page 6-82.
- 5. Remove the tilt mechanism.

6-2-10 CRT Assy (FRU No. 115) (continued)

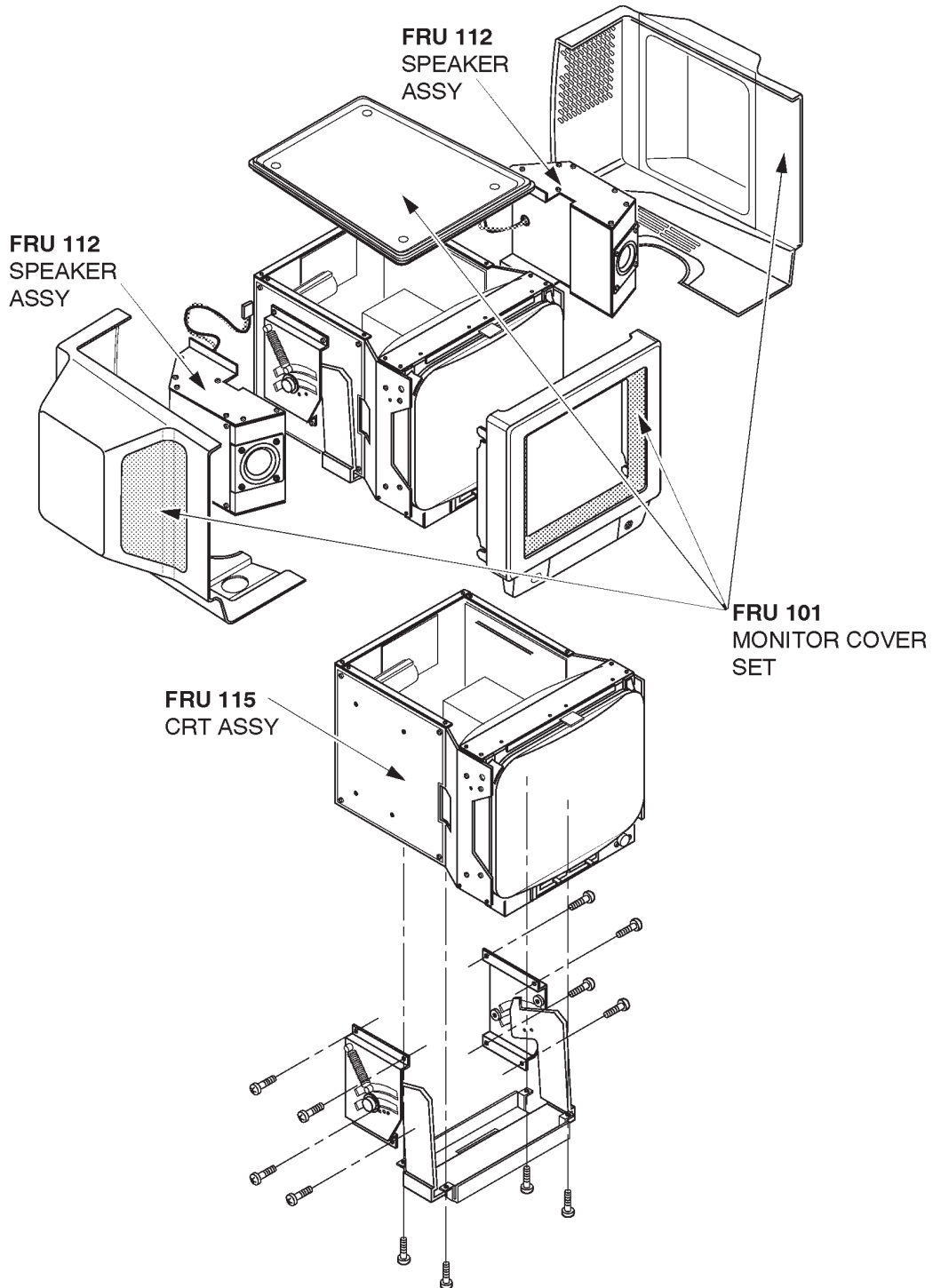

CRT ASSY DISASSEMBLY
ILLUSTRATION 6-26

Note

The CRT Assy does not include the tilt mechanism.

6-2-11 CRT Cable Set (FRU No. 116)**Time Required**

0.5 Hours

Tool RequiredScrewdriver
Hexagonal Wrench**Procedure**

■ Refer to ILLUSTRATION 6-27.

1. Turn OFF the system.
2. Remove the Monitor Assy (FRU 100). Refer to 6-2-1 on page 6-70.
3. Remove the Monitor Cover Set (FRU 101). Refer to 6-2-2 on page 6-72.
4. Disconnect three connectors (①) – (③) from the back side of the CRT Assy.

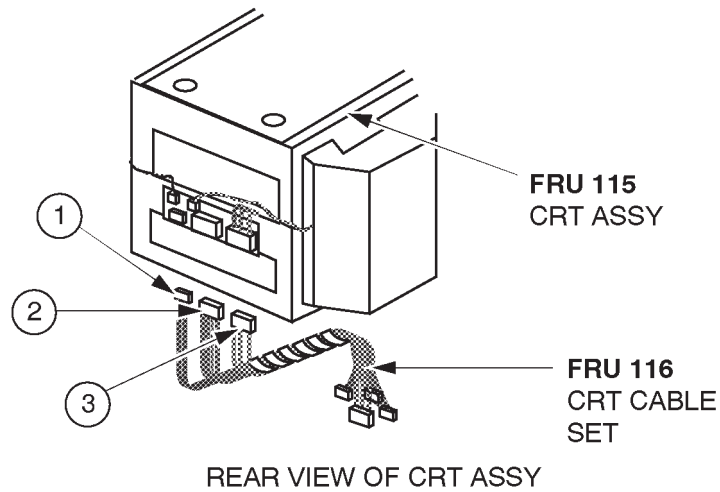

CRT ASSY DISASSEMBLY
ILLUSTRATION 6-27

This page is left blank intentionally.

6–2–12 Monitor Assy NTSC (FRU No. 150), Monitor Assy PAL (FRU No. 151)**Time Required**

0.25 Hours

Tool RequiredScrewdriver
Hexagonal Wrench**Procedure****WARNING!**

PERSONAL INJURY HAZARD. THE NECK ASSY IS SPRING LOADED. RELEASING ARM WHEN MONITOR IS NOT INSTALLED WILL CAUSE SUDDEN UPWARD MOVEMENT. KEEP YOUR HEAD AND BODY AWAY FROM ABOVE NECK ASSY.

■ Refer to ILLUSTRATION 6–28 on page 6–91.

1. Turn OFF the system.
2. Unscrew four hexagonal screws (① – ④) located beneath the horizontal part of the Neck Assy.
3. Remove the cover located at the bottom of the Neck Assy.
4. Unscrew two screws (⑤ and ⑥) and remove the plate fixing the cables.
5. Disconnect the three connectors (⑦ – ⑨).
6. Remove two screw caps located at position (⑩ and ⑪).
7. Loosen two screws (⑩ and ⑪) and pull the Monitor Assy upwards.

Note

When replacing the monitor with the new Monitor Assy (2164505 or 2164506), be sure to attach the proper label included with the monitor on to the Escutcheon. To attach the new label, refer to the procedures in section 6–2–14 on page 6–93.

6-2-12 Monitor Assy NTSC (FRU No. 150), Monitor Assy PAL (FRU No. 151) (continued)

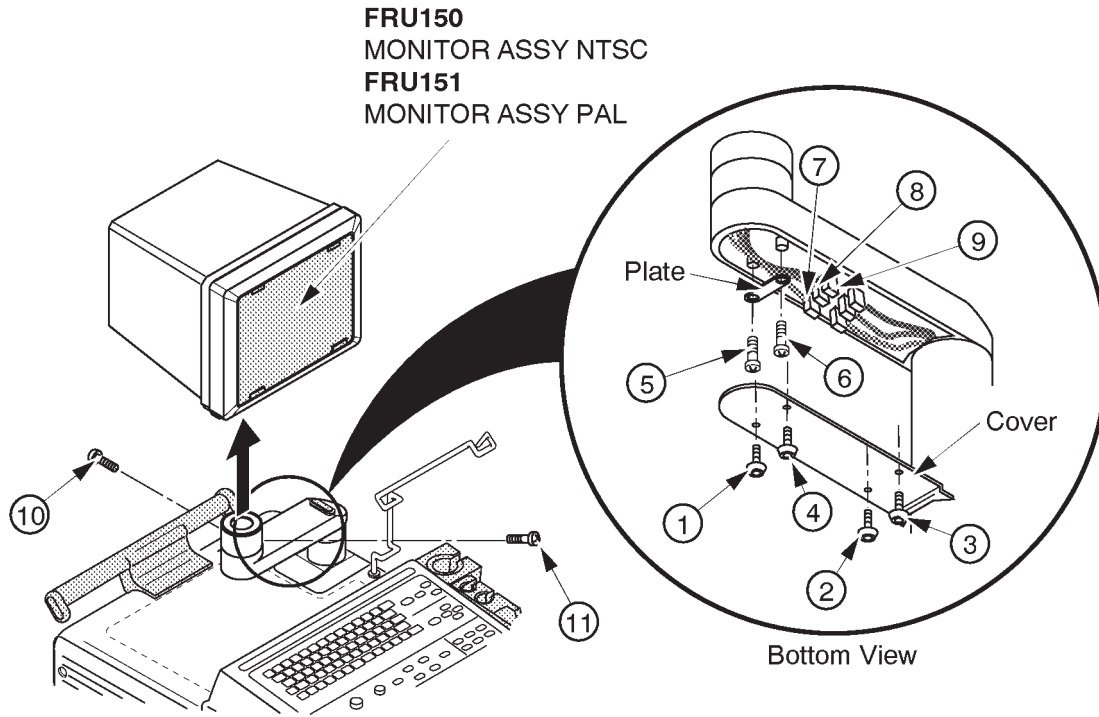

MONITOR ASSY NTSC/PAL DISASSEMBLY
ILLUSTRATION 6-28



6-2-13 Monitor Cover (FRU No. 152)**Time Required**

5 Minutes

Tool Required

Screwdriver

Procedure

- Refer to ILLUSTRATION 6-29.
- 1. Turn OFF the system.
- 2. Remove the Monitor Bottom Assy. Refer to 6-2-17 on page 6-98.
- 3. Unscrew four screws (① – ④).
- 4. Remove the Monitor Cover (FRU 152).

**MONITOR COVER DISASSEMBLY**

ILLUSTRATION 6-29

6-2-14 Escutcheon Assy (FRU No. 153)**Time Required**

10 Minute

Tool Required

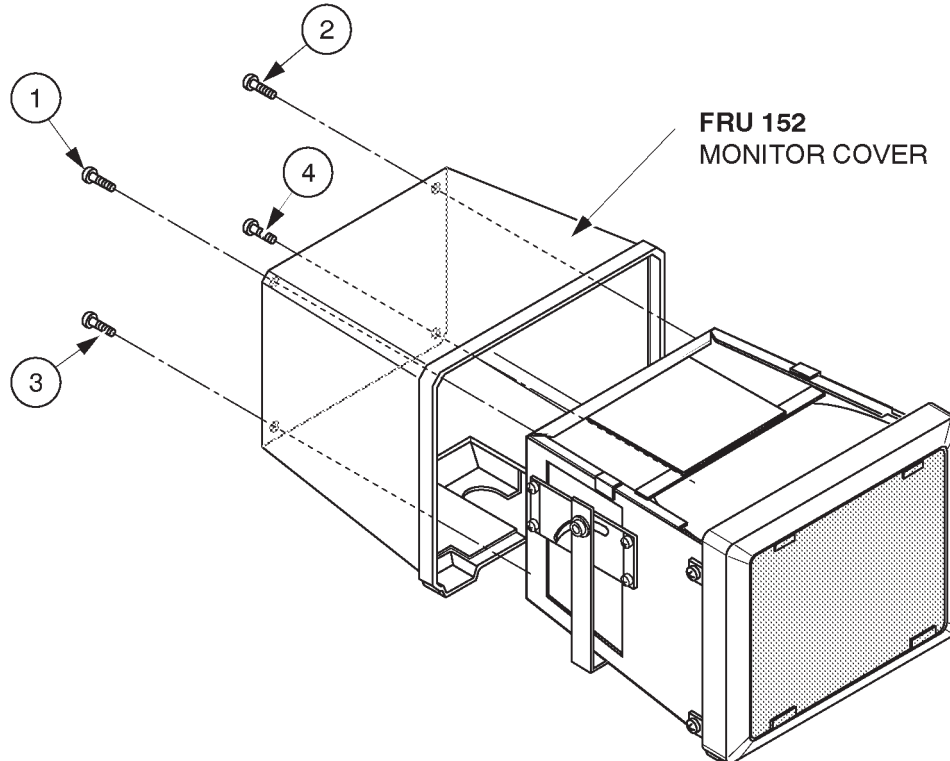
Screwdriver

Procedure

- Refer to ILLUSTRATION 6-30.
- 1. Turn OFF the system.
- 2. Remove the Monitor Cover (FRU 152). Refer to 6-2-13 on page 6-92.
- 3. Unscrew four screws (① – ④).
- 4. Remove the Escutcheon Assy (FRU 153).

Note

When replacing the Escutcheon with the new Escutcheon Assy (2164507), Be sure to attach the proper label included with the Escutcheon Assy on to the Escutcheon. To attach the new label, refer to the procedures described in the following pages.

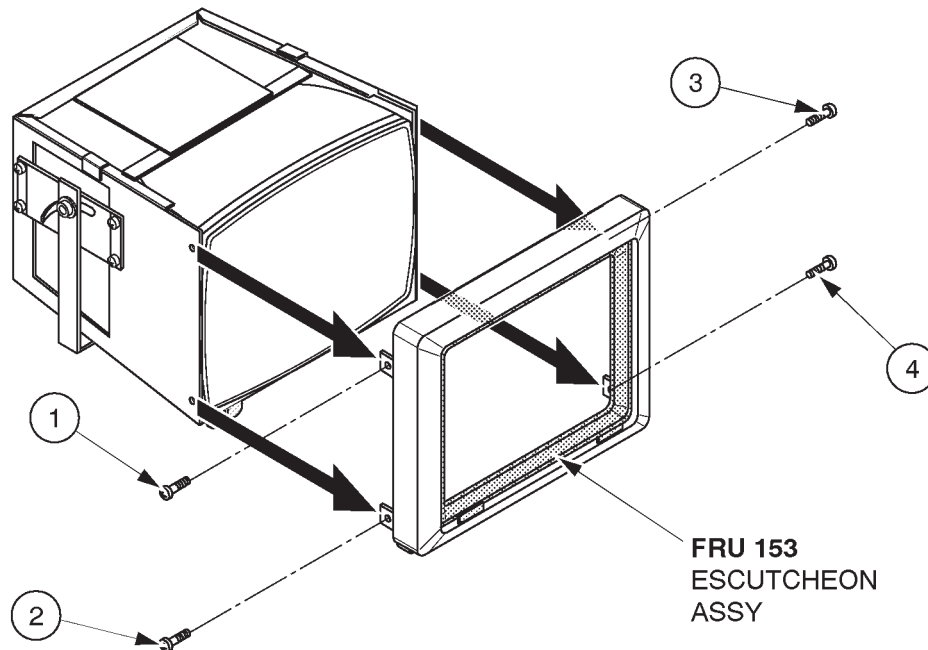

ESCUTCHEON ASSY REMOVAL
ILLUSTRATION 6-30

6-2-14 Escutcheon Assy (FRU No. 153) (continued)

Note

The new Escutcheon Assy (2164507) includes the two different labels for the Escutcheon. When replacing the Escutcheon with the new Escutcheon Assy, be sure to attach the proper label on to the Escutcheon as follows:

- a. Choose the proper label, "LOGIQ 400" or "LOGIQ 400 MD" indicating the same model name as the label on the removed Escutcheon.
- b. Remove the lower pasteboard from the proper label. Refer to ILLUSTRATION 6-31.

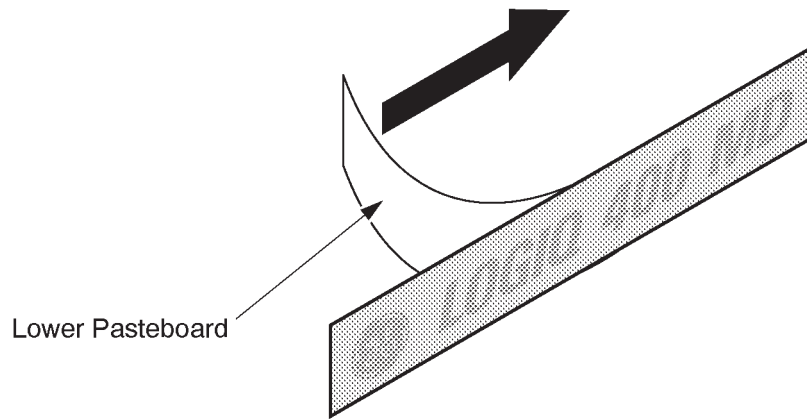

REMOVING LOWER PASTEBOARD
ILLUSTRATION 6-31

- c. Set and attach the label on the Escutcheon. Adjust the position of the label attached as shown in ILLUSTRATION 6-32. Be careful not to attach the label with a misalignment.

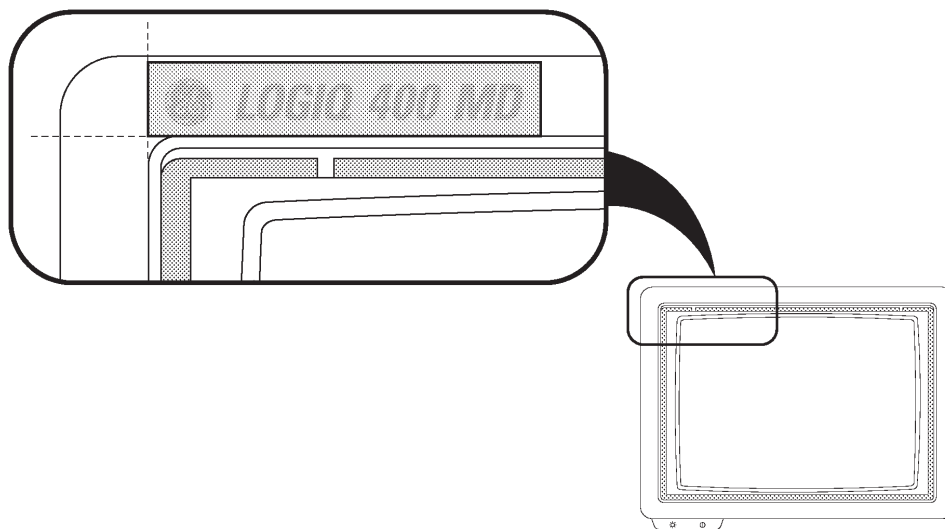

ATTACHING LABEL
ILLUSTRATION 6-32

6-2-14 Escutcheon Assy (FRU No. 153) (continued)

d. Press down the label all around.

■ e. Remove the upper pasteboard from the label. refer to ILLUSTRATION 6-33.

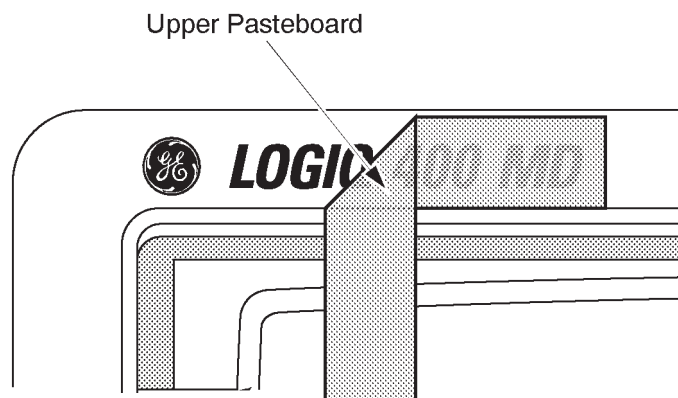

■ **REMOVING UPPER PASTEBOARD**
ILLUSTRATION 6-33

6-2-15 Fixing Metal Plate (FRU No. 154)**Time Required**

5 Minute

Tool Required

Screwdriver

Procedure

- Refer to ILLUSTRATION 6-34.

1. Turn OFF the system.
- 2. Remove the Monitor Bottom Assy (FRU 157). Refer to 6-2-17 on page 6-98.
3. Pull out the Fixing Metal Plate (FRU 154) from the Escutcheon Assy (FRU 153).

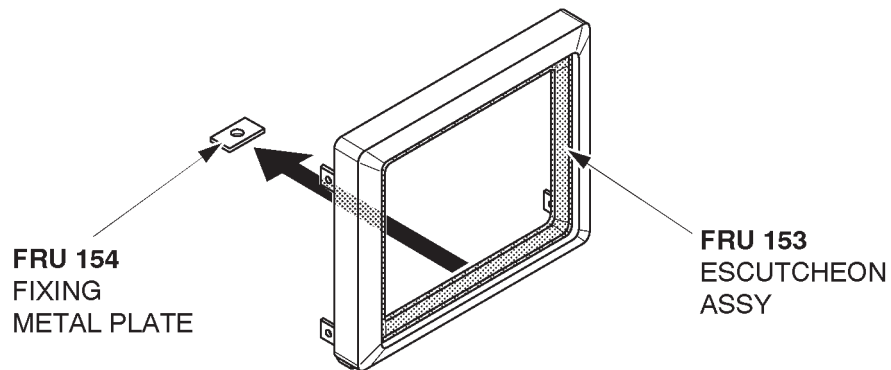

FIXING METAL PLATE REMOVAL
ILLUSTRATION 6-34



6-2-16 CRT Filter (FRU No. 155), CRT Filter Clamp Set (FRU No. 156)**Time Required**

1 Minute

Tool Required

Not necessary

Procedure

■ Refer to ILLUSTRATION 6-35.

1. Turn OFF the system.
2. Slide the filter clamp at left side leftwards and pull it out.
3. Slide the filter clamp at right side rightwards and pull it out.
4. Remove the CRT Filter (FRU 155).

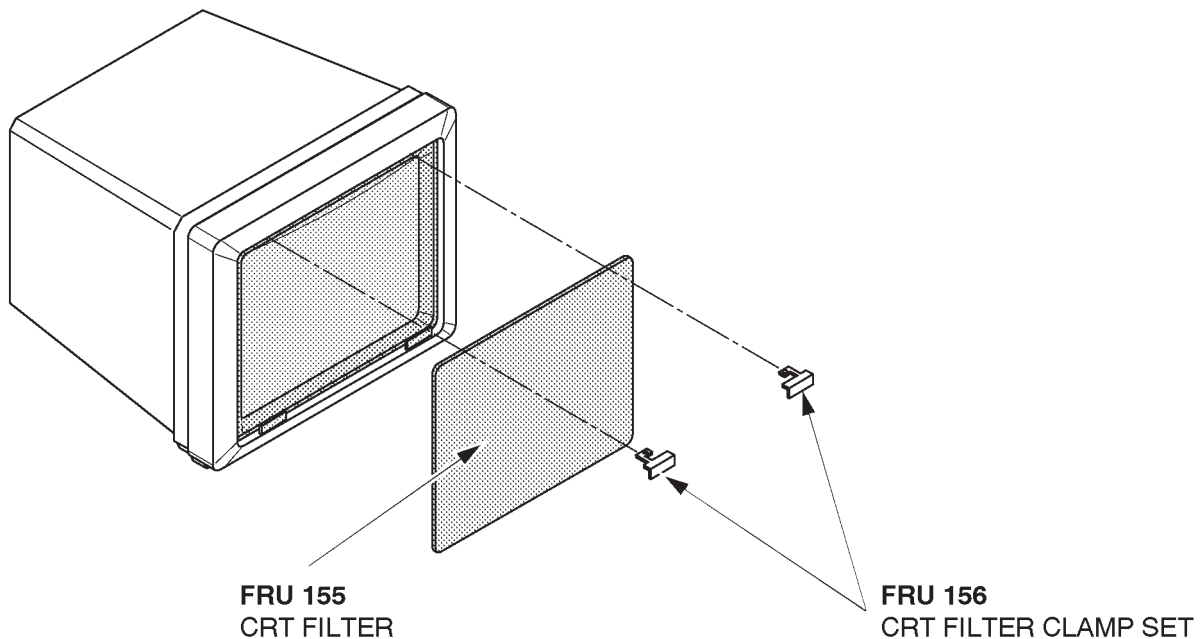

CRT FILTER CLAMP AND CRT FILTER REMOVAL
ILLUSTRATION 6-35

Note

When reinstalling the CRT filter, you will hear a “click” sound when the filter clamp is secured by the lock mechanism. This indicates it is properly installed.

6-2-17 Monitor Bottom Assy (FRU No. 157)**Time Required**

5 Minutes

Tool Required

Screwdriver

Procedure

■ Refer to ILLUSTRATION 6-36.

1. Turn OFF the system.
2. Unscrew one screw (①).
3. Disconnect two connectors (② and ③).
4. Remove the Monitor Bottom Assy (FRU 157).
5. Remove the Stud.

**MONITOR BOTTOM ASSY DISASSEMBLY**

ILLUSTRATION 6-36

This page is left blank intentionally.

6-2-18 CRT Assy NTSC (FRU No. 158), CRT Assy PAL (FRU No. 159)**Time Required**

0.5 Hours

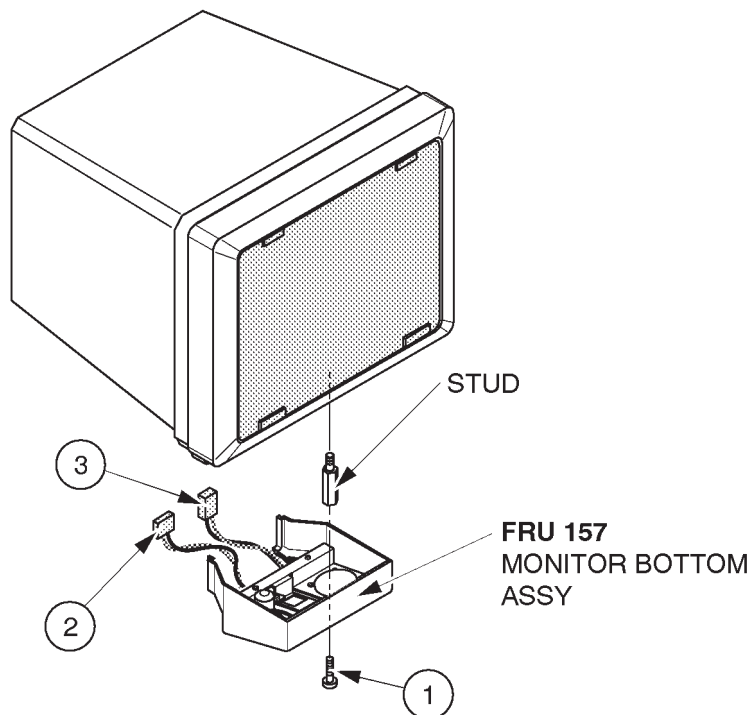
Tool Required

Screwdriver

Procedure**WARNING!**

PERSONAL INJURY HAZARD. THE NECK ASSY IS SPRING LOADED. RELEASING ARM WHEN MONITOR IS NOT INSTALLED WILL CAUSE SUDDEN UPWARD MOVEMENT. KEEP YOUR HEAD AND BODY AWAY FROM ABOVE NECK ASSY.

■ Refer to ILLUSTRATION 6-37 on page 6-101.

1. Turn OFF the system.
2. Remove the Monitor Assy NTSC/PAL (FRU 150/151). Refer to 6-2-12 on page 6-90.
3. Remove the Monitor Bottom Assy (FRU 157). Refer to 6-2-17 on page 6-98.
4. Remove the Monitor Cover (FRU 152). Refer to 6-2-13 on page 6-92.
5. Remove the Escutcheon Assy (FRU 153). Refer to 6-2-14 on page 6-93.
6. Remove the CRT Cable Set (FRU 160). Refer to 6-2-19 on page 6-102.

6-2-18 CRT Assy NTSC (FRU No. 158), CRT Assy PAL (FRU No. 159) (continued)

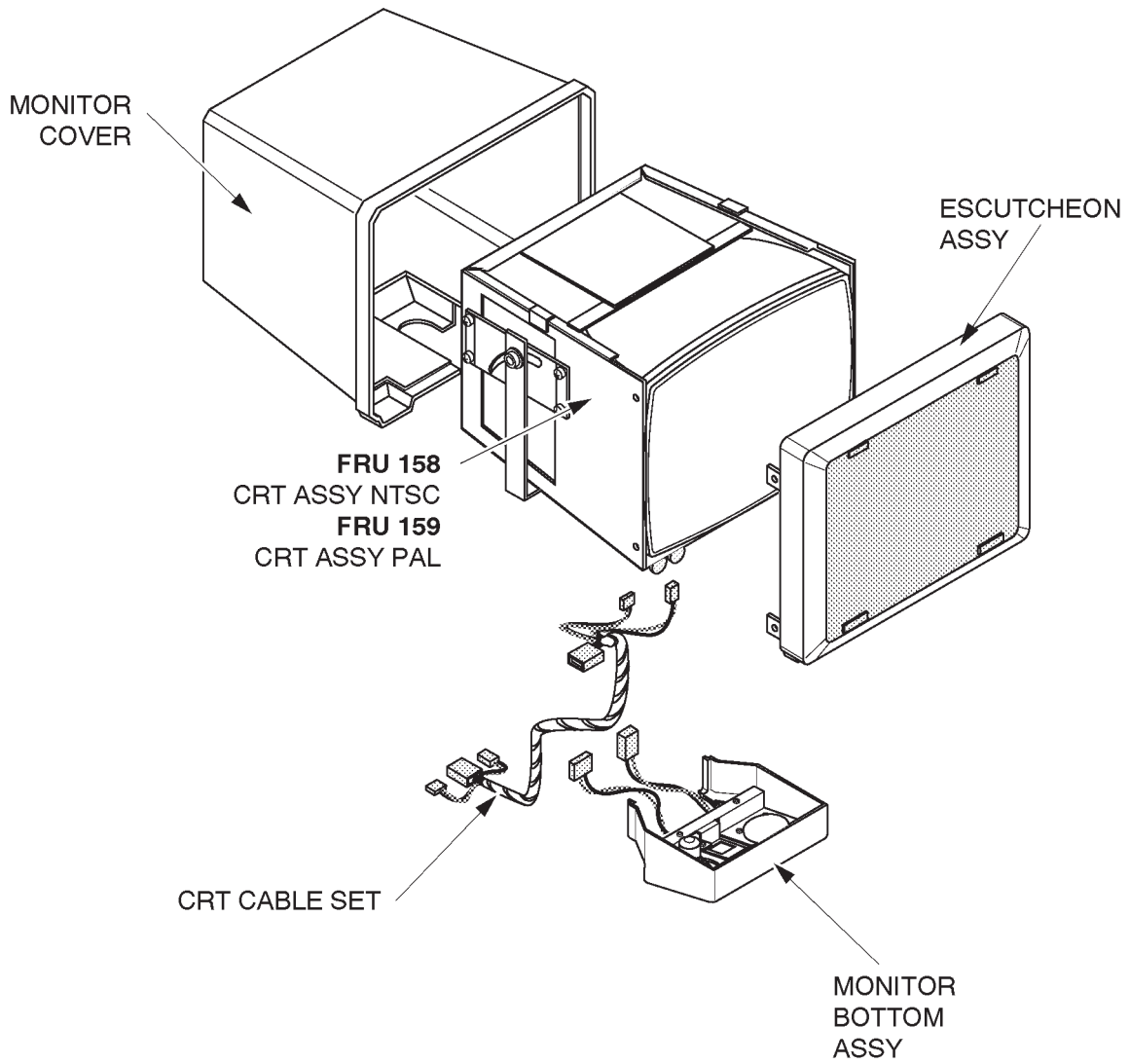

CRT ASSY NTSC/PAL DISASSEMBLY
ILLUSTRATION 6-37



6-2-19 CRT Cable Set (FRU No. 160)**Time Required**

0.5 Hours

Tool Required

Screwdriver

Hexagonal Wrench

Procedure

■ Refer to ILLUSTRATION 6-38.

1. Turn OFF the system.
2. Remove the Monitor Assy NTSC/PAL(FRU 150/151). Refer to 6-2-12 on page 6-90.
3. Remove the Monitor Bottom Assy (FRU 157). Refer to 6-2-17 on page 6-98.
4. Disconnect one connector (①) and remove the CRT Cable Set.

**CRT CABLE SET DISASSEMBLY**

ILLUSTRATION 6-38

6-2-20 CRT Lamp (FRU No. 161)**Time Required**

10 Minutes

Tool Required

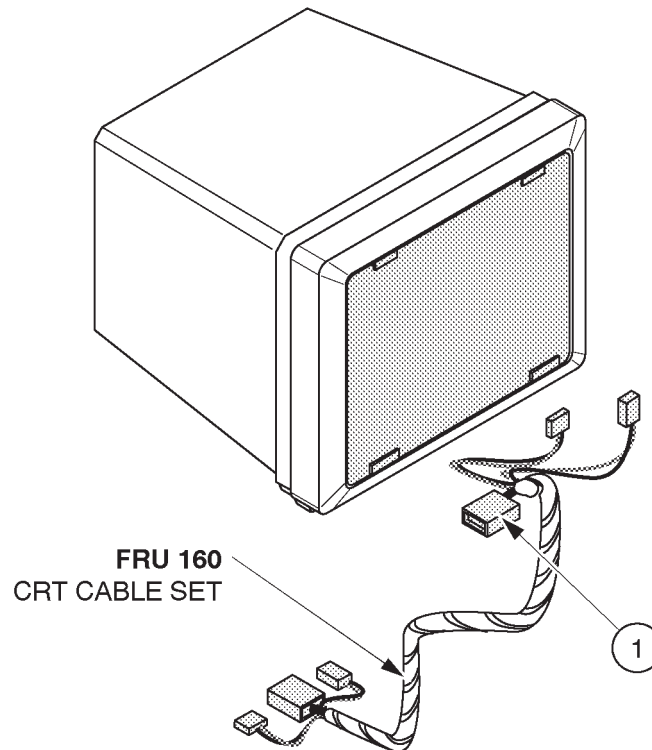
Screwdriver

Procedure

- Refer to ILLUSTRATION 6-39.
- 1. Turn OFF the system.
- 2. Remove the Monitor Bottom Assy (FRU 157). Refer to 6-2-17 on page 6-98.
- 3. Unscrew two screws (① and ②) to remove the bracket of Monitor Bottom Assy as shown in ■ ILLUSTRATION 6-39.
- 4. Turn the CRT Lamp counterclockwise and remove it.

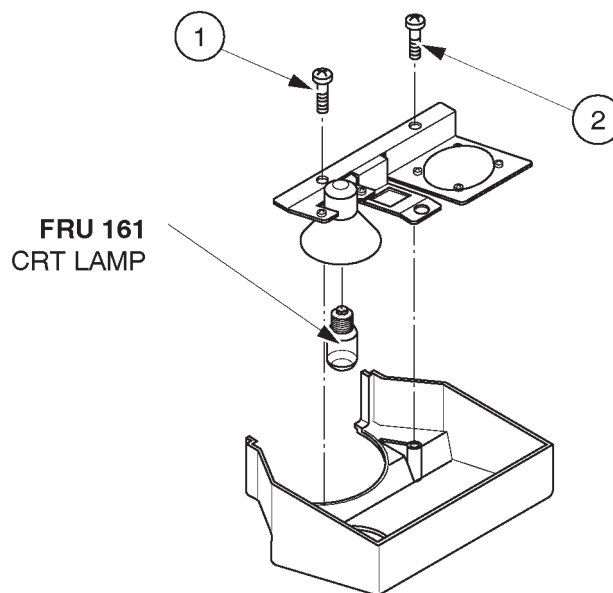

CRT LAMP DISASSEMBLY
ILLUSTRATION 6-39

6–2–21 Monitor15 Assy (FRU No. 170)**Time Required**

0.25 Hours

Tool Required

Screwdriver

Hexagonal Wrench

Procedure

PERSONAL INJURY HAZARD. VIDEO MONITOR SUPPORT ARM IS SPRING LOADED. RELEASING ARM WHEN MONITOR IS NOT INSTALLED WILL CAUSE SUDDEN UPWARD MOVEMENT. KEEP YOUR HEAD AND BODY AWAY FROM ABOVE VIDEO MONITOR SUPPORT ARM.

Refer to ILLUSTRATION 6–40 on page 6–105.

1. Turn OFF the system.
2. Remove the CRT Filter. Refer to ILLUSTRATION 6–35 on page 6–97.
3. Unscrew four hexagonal screws (① – ④) located beneath the horizontal part of the Neck Assy.
4. Remove the cover located at the bottom of the Neck Assy.
5. Unscrew two screws (⑤ and ⑥) and remove the plate fixing the cables.
6. Disconnect the four connectors (⑦ – ⑩).
7. Remove the screw cap located at position (⑪).
8. Loosen one screw (⑪) and pull the Monitor15 Assy upwards.

Note

The Monitor 15 Assy (FRU170) does not include the CRT Filter15 Set (FRU176).

6-2-21 Monitor15 Assy (FRU No. 170) (continued)

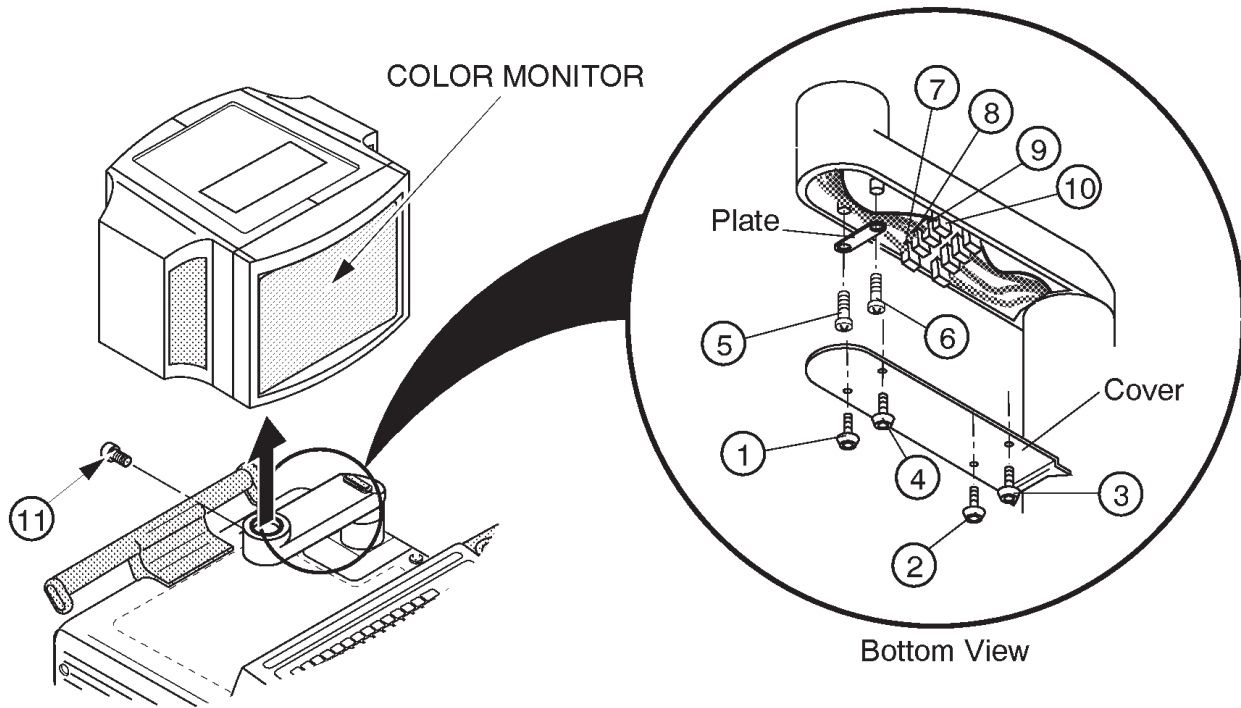

MONITOR15 BLOCK ASSY DISASSEMBLY
ILLUSTRATION 6-40

6–2–22 Monitor15 Cover Set (FRU No. 171)**Time Required**

20 Minutes

Tool Required

Screwdriver

Procedure

Refer to ILLUSTRATION 6–41 on page 6–107.

1. Turn OFF the system.
2. Unscrew two screws (① – ②).
3. Remove the LAMP SHADE2 (FRU179).
4. Unscrew six screws (③ – ⑧).
5. Remove the Monitor Cover L2 Assy (FRU 173) and R2 Assy (FRU 174).
6. Remove the Tray2 Assy (FRU 175).
7. Loosen four screws (⑨ – ⑫).
8. Remove the Escutcheon2 Assy (FRU 172).
9. Disconnect one connector (⑬).
10. Disconnect one connector (⑭) from the back side of the Escutcheon2 Assy.

Note

Monitor15 Cover Set includes the Monitor Cover L2 Assy (FRU 173), Monitor Cover R2 Assy (FRU 174), Tray2 Assy (FRU 175), and the Escutcheon2 Assy (FRU 172).

6-2-22 Monitor15 Cover Set (FRU No. 171) (continued)

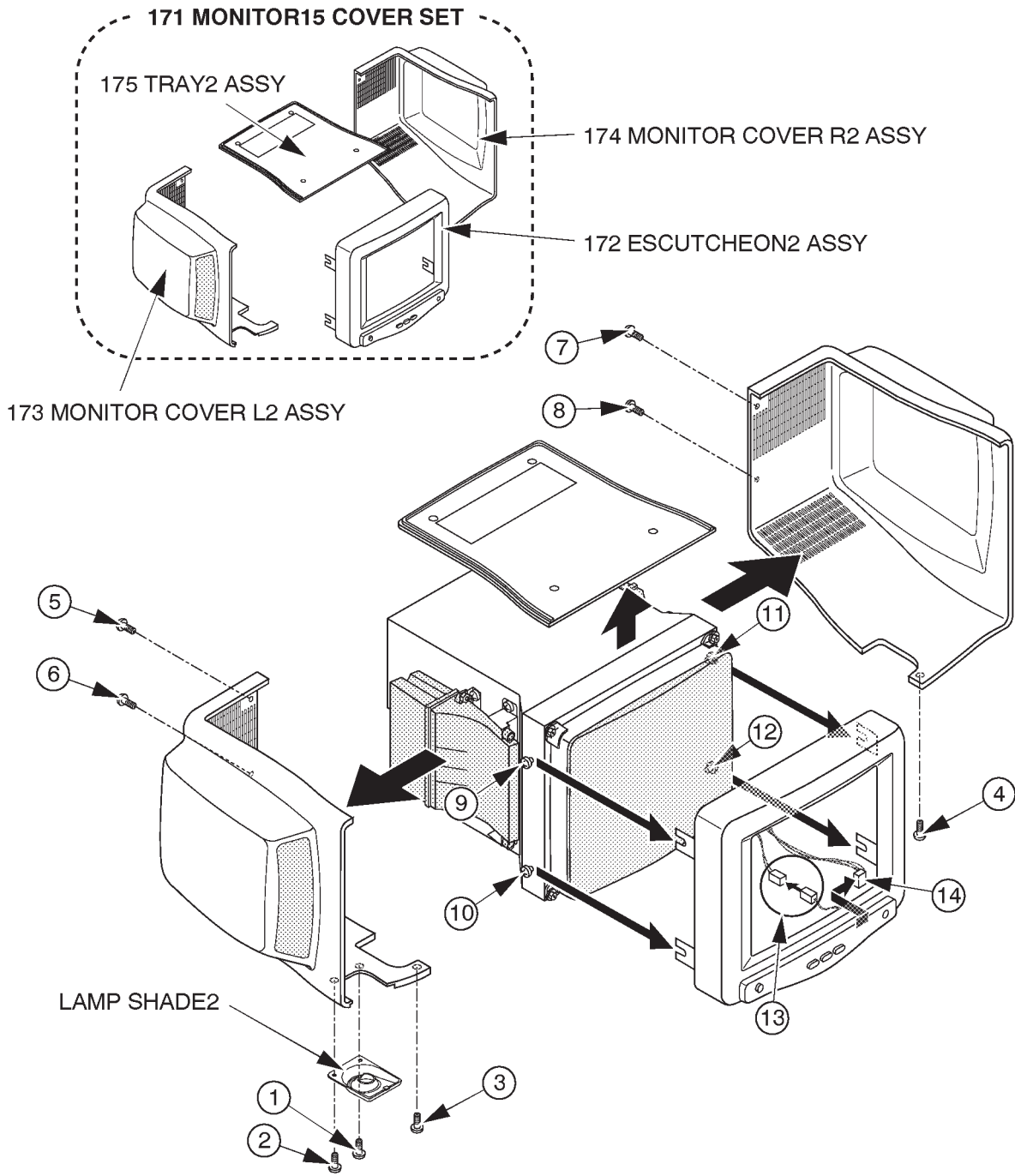

MONITOR COVER SET DISASSEMBLY
ILLUSTRATION 6-41

6-2-22 Monitor15 Cover Set (FRU No. 171) (continued)

Note

The new Escutcheon2 Assy (2265744) includes the two different labels for the Escutcheon. When replacing the Escutcheon with the new Escutcheon2 Assy, be sure to attach the proper label on to the Escutcheon as follows:

- a. Choose the proper label, "LOGIQ 400 PRO" indicating the same model name as the label on the removed Escutcheon.
- b. Remove the lower pasteboard from the proper label. Refer to ILLUSTRATION 6-42.

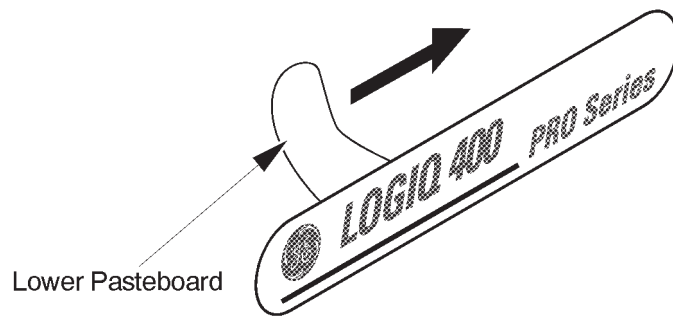

REMOVING LOWER PASTEBOARD
ILLUSTRATION 6-42

- c. Set and attach the label on the Escutcheon. Adjust the position of the label attached as shown in ILLUSTRATION 6-32. Be careful not to attach the label with a misalignment.

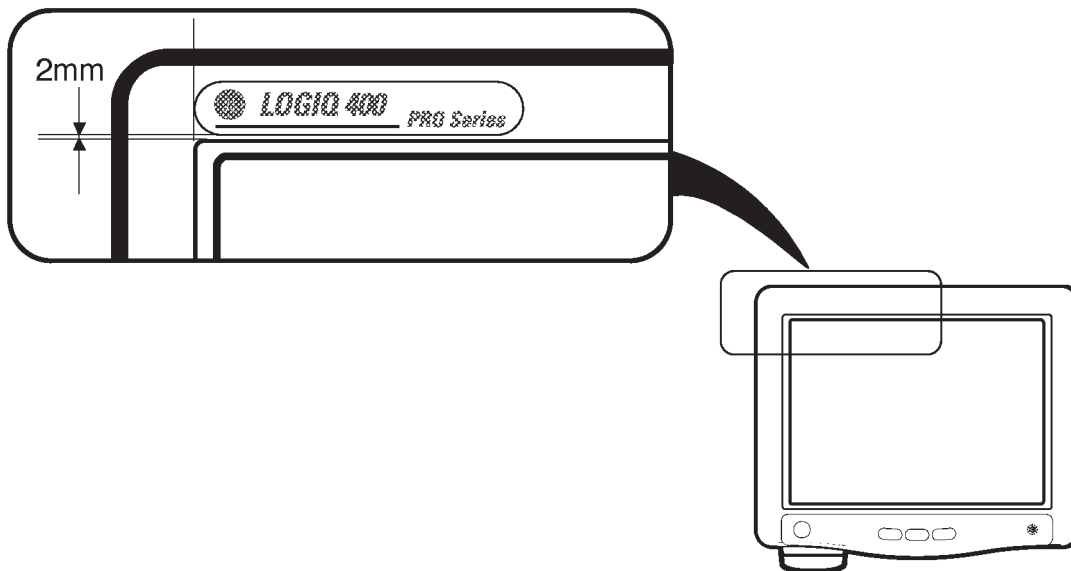

ATTACHING LABEL
ILLUSTRATION 6-43

6–2–23 Speaker Assy (FRU No. 178)**Time Required**

0.5 Hours

Tool Required

Screwdriver

Procedure

Refer to ILLUSTRATION 6–44.

1. Turn OFF the system.
2. Remove the Monitor Cover L2 Assy (FRU 173) and Monitor Cover R2 Assy (FRU 174). Refer to 6–2–22 on page 6–106.
4. Unscrew eight screws (① – ⑧).
5. Disconnect one connector for each speaker from the back side of the monitor.
6. Remove the Speakers.

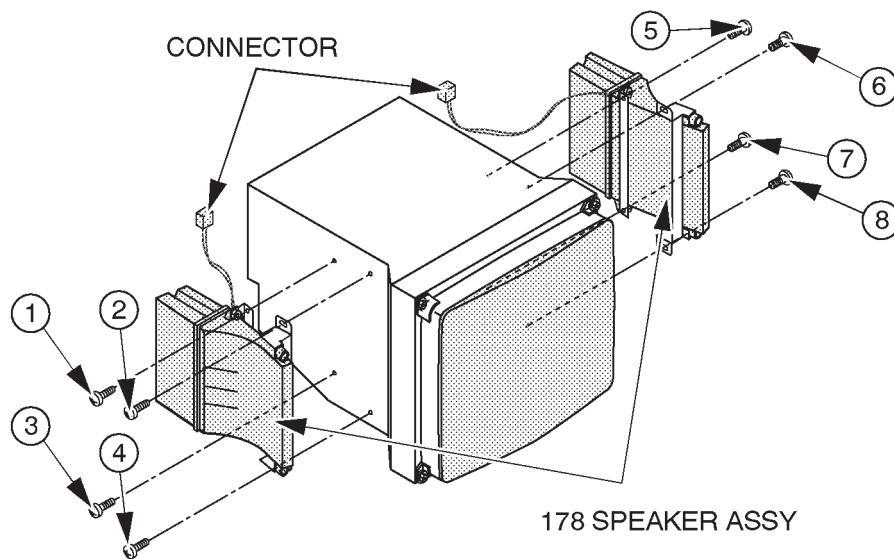

SPEAKER ASSY DISASSEMBLY
ILLUSTRATION 6–44

Note

Left and right speakers are interchangeable.

6-2-24 TASK Lamp (FRU No. 180)**Time Required**

0.5 Hours

Tool Required

Screwdriver

Procedure

Refer to ILLUSTRATION 6-45.

1. Turn OFF the system.
2. Unscrew two screws (① and ②).
3. Remove the Lamp Shade2.
4. Remove the TASK LAMP (FRU 180).

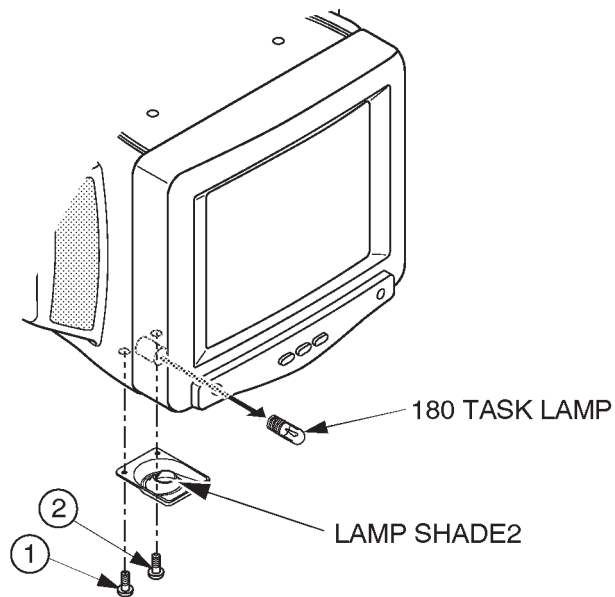

TASK LAMP DISASSEMBLY
ILLUSTRATION 6-45

6-2-25 CRT Cable Set (FRU No. 182)**Time Required**

0.5 Hour

Tool Required

Screwdriver

Hexagonal Wrench

Procedure

Refer to ILLUSTRATION 6-46.

1. Turn OFF the system.
2. Remove the Monitor15 Assy (FRU 170). Refer to 6-2-21 on page 6-104.
3. Remove the Monitor15 Cover Set (FRU 171). Refer to 6-2-22 on page 6-106.
4. Disconnect three connectors (① – ③) from the back side of the CRT Assy.

**CRT ASSY DISASSEMBLY**

ILLUSTRATION 6-46

This page is left blank intentionally.

This page is left blank intentionally.

6-2-26 Neck Assy (FRU No. 201 for Color Monitor, No. 202 for B/W Monitor)**Time Required**

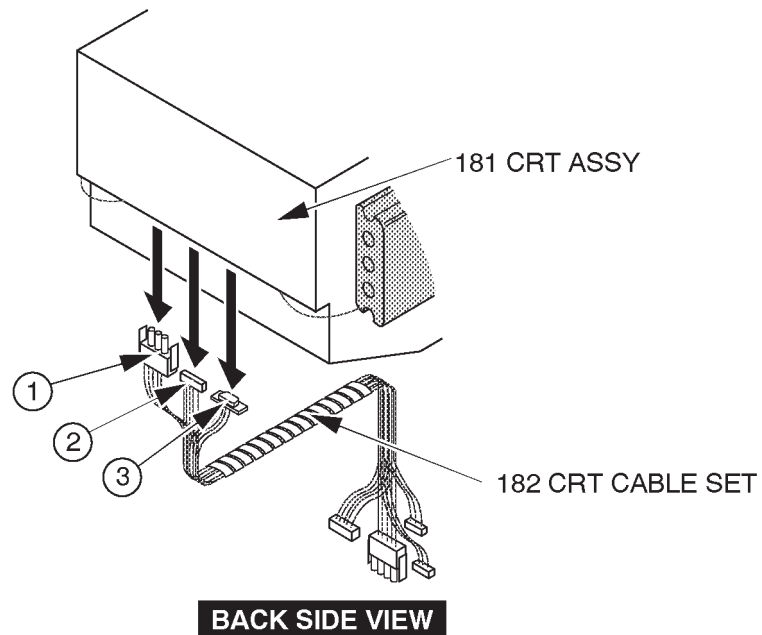
30 Minutes

Tool RequiredScrewdriver
Hex Wrench**Procedure****WARNING!**

PERSONAL INJURY HAZARD. THE NECK ASSY IS SPRING LOADED. RELEASING ARM WHEN MONITOR IS NOT INSTALLED WILL CAUSE SUDDEN UPWARD MOVEMENT. KEEP YOUR HEAD AND BODY AWAY FROM ABOVE NECK ASSY.

Refer to ILLUSTRATION 6-47 on page 6-115.

1. Turn OFF the system and unplug the unit.
2. Push down the Up/Down Release Button located on the Neck Assy, lift the monitor up and set the monitor to the highest position.
3. Remove the Monitor Assy (FRU No. 100), Monitor Assy NTSC (FRU No. 150) or Monitor Assy PAL (FRU No. 151). Refer to 6-2-1 on page 6-70 or 6-2-12 on page 6-90.
4. Remove the Neck Space Plate.
5. Remove the Front Base Cover (FRU 305). Refer to 6-2-35 on page 6-131.
6. Remove the Side Cover Right (FRU 302). Refer to 6-2-32 on page 6-128.

Note

The Linear Slide Cover is installed from the production unit of LOGIQ™400 console with software Version 5.01y or later. Refer to ILLUSTRATION 6-48 on page 6-116. Unscrew six screws (⑰ – ⑳) to remove the Linear Slide Cover.

7. Remove the Side Cover Left (FRU 301). Refer to 6-2-31 on page 6-127.
8. Remove the Rear Cover (FRU 303). Refer to 6-2-33 on page 6-129.
9. Remove the Top Cover (FRU 308). Refer to 6-2-38 on page 6-135.
10. Remove the Rear CONN Panel Assy (FRU 501). Refer to 6-2-61 on page 6-166.

6-2-26 Neck Assy (FRU No. 201 for Color Monitor, No. 202 for B/W Monitor) (continued)

11. Disconnect one connector (①).
12. Disconnect two connectors (② and ③) from the P25A and P26A connectors on Mother Board.
13. Disconnect one flat cable (④).
14. Cut off the tie wraps to bind cables.
15. Remove thirteen hexagonal bolts (⑤ – ⑰).
16. Remove the Neck Assy from console.

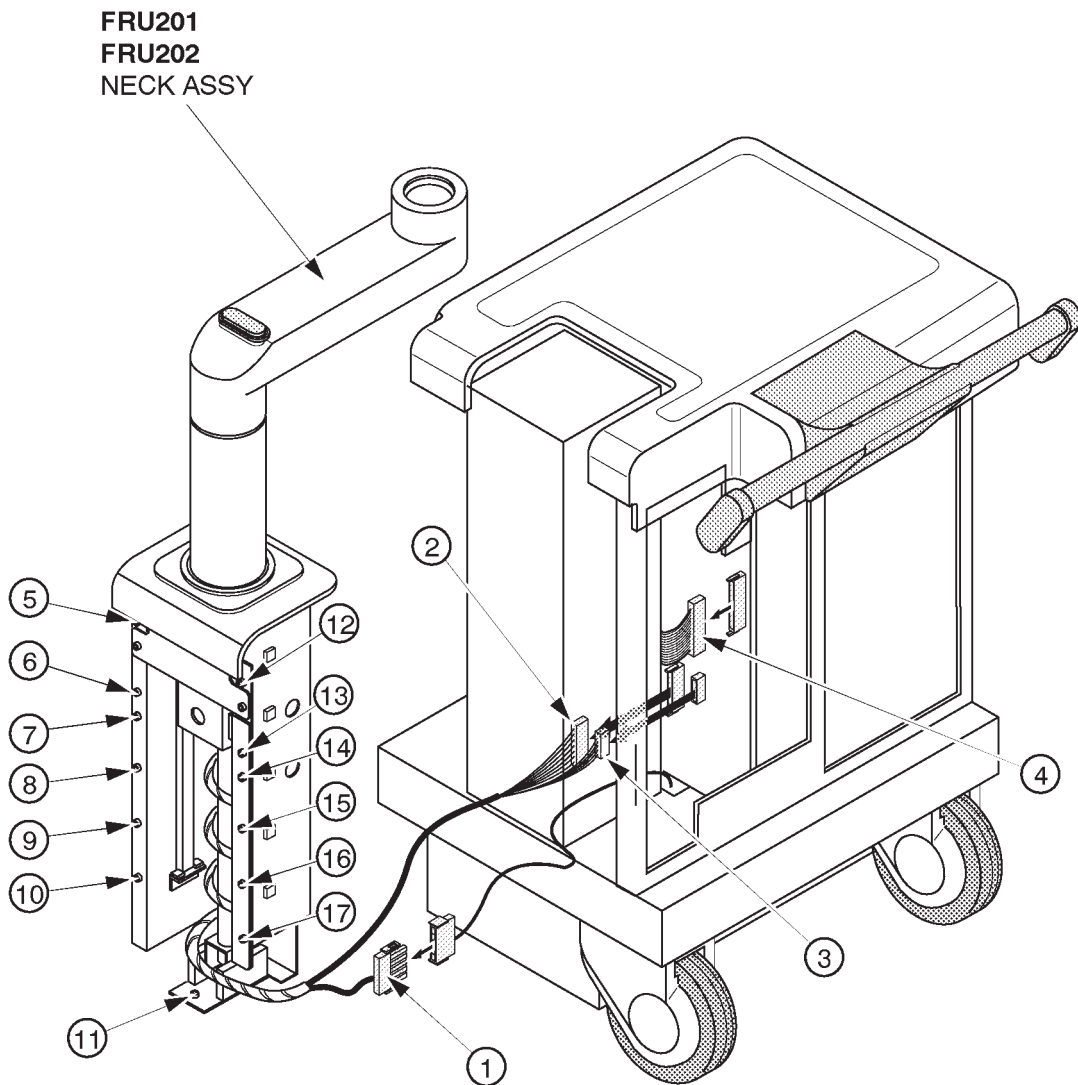

NECK ASSY DISASSEMBLY
ILLUSTRATION 6-47

6-2-26 Neck Assy (FRU No. 201 for Color Monitor, No. 202 for B/W Monitor) (continued)

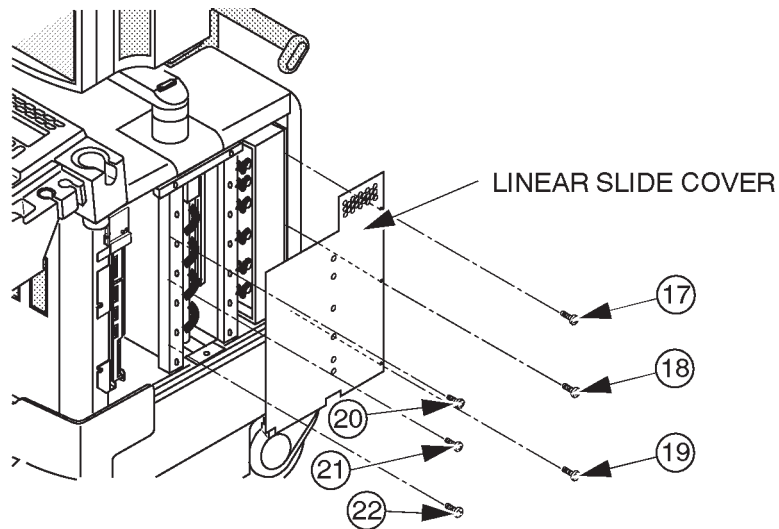

LINEAR SLIDE COVER DISASSEMBLY
ILLUSTRATION 6-48

■ **6-2-27 Neck Grip (FRU No. 203)**

Time Required

5 Minutes

Tool Required

Hexagonal Wrench

Procedure

■ Refer to ILLUSTRATION 6-49.

1. Turn OFF the system.
2. Loosen two hexagonal screws (① and ②).
3. Remove the Neck Grip.

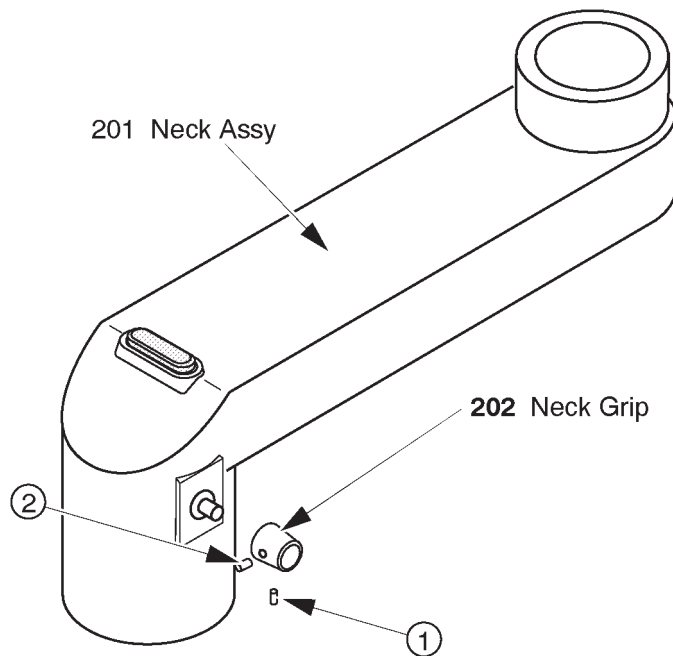

NECK GRIP DISASSEMBLY
ILLUSTRATION 6-49

■

This page is left blank intentionally.

This page is left blank intentionally.

6-2-28 Neck Space Plate (FRU No. 204)**Time Required**

0.5 Hours

Tool RequiredScrewdriver
Hexagonal Wrench**Procedure****WARNING!**

PERSONAL INJURY HAZARD. THE NECK ASSY IS SPRING LOADED. RELEASING ARM WHEN MONITOR IS NOT INSTALLED WILL CAUSE SUDDEN UPWARD MOVEMENT. KEEP YOUR HEAD AND BODY AWAY FROM ABOVE NECK ASSY.

Refer to ILLUSTRATION 6-50 on page 6-121.

1. Turn OFF the system.
2. Remove the Monitor Assy (FRU No. 100), Monitor Assy NTSC (FRU No. 150) or Monitor Assy PAL (FRU No. 151). Refer to 6-2-1 on page 6-70 or 6-2-12 on page 6-90.
3. Remove the Neck Space Plate 2. Refer to 6-2-29 on page 6-122. The Neck Space Plate 2 is used only for the B/W monitor console. In case of color monitor console, skip this step.
4. Remove the Rotation Spacer. Refer to 6-2-30 on page 6-124. The Rotation Spacer is used only for the B/W monitor console. In case of color monitor console, skip this step.
5. Remove the Neck Space Plate.

■ 6-2-28 Neck Space Plate (FRU No. 204) (continued)

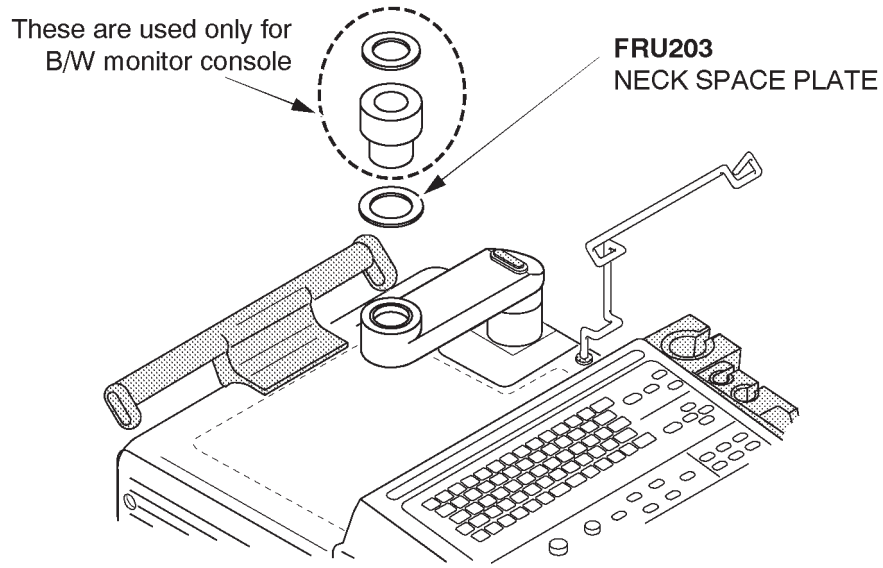

■ **NECK SPACE PLATE DISASSEMBLY**
ILLUSTRATION 6-50

6-2-29 Neck Space Plate 2 (FRU No. 205)**Note**

The Neck Space Plate 2 is used only for the B/W monitor console.

Time Required

0.5 Hours

Tool Required

Screwdriver

Hexagonal Wrench

Procedure**WARNING!**

PERSONAL INJURY HAZARD. THE NECK ASSY IS SPRING LOADED. RELEASING ARM WHEN MONITOR IS NOT INSTALLED WILL CAUSE SUDDEN UPWARD MOVEMENT. KEEP YOUR HEAD AND BODY AWAY FROM ABOVE NECK ASSY.

Refer to ILLUSTRATION 6-51 on page 6-123.

1. Turn OFF the system.
2. Remove the Monitor Assy NTSC (FRU No. 150) or Monitor Assy PAL (FRU No. 151). Refer to 6-2-12 on page 6-90.
3. Remove the Neck Space Plate 2.

■ 6-2-29 Neck Space Plate 2 (FRU No. 205) (continued)

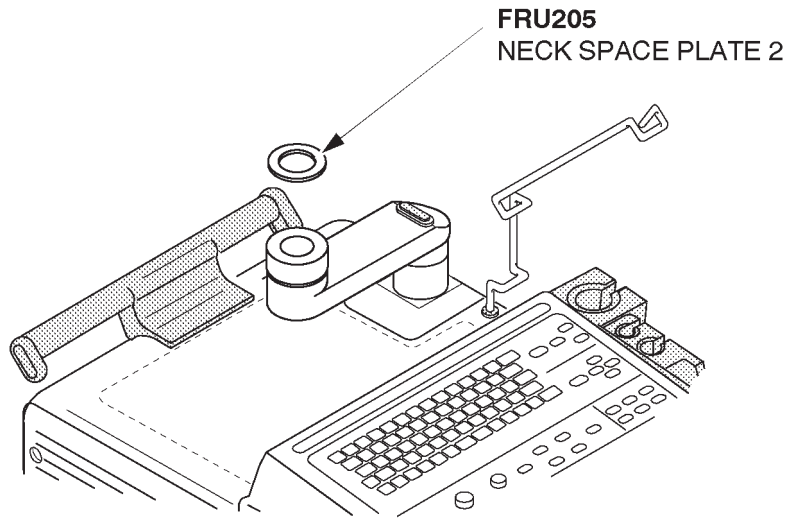

■ **NECK SPACE PLATE 2 DISASSEMBLY**
ILLUSTRATION 6-51

6-2-30 Rotation Spacer (FRU No. 206)**Note**

The Rotation Spacer is used only for the B/W monitor console.

Time Required

0.5 Hours

Tool Required

Screwdriver

Hexagonal Wrench

Procedure**WARNING!**

PERSONAL INJURY HAZARD. THE NECK ASSY IS SPRING LOADED. RELEASING ARM WHEN MONITOR IS NOT INSTALLED WILL CAUSE SUDDEN UPWARD MOVEMENT. KEEP YOUR HEAD AND BODY AWAY FROM ABOVE NECK ASSY.

Refer to ILLUSTRATION 6-52 on page 6-125.

1. Turn OFF the system.
2. Remove the Monitor Assy NTSC (FRU No. 150) or Monitor Assy PAL (FRU No. 151). Refer to 6-2-12 on page 6-90.
3. Unscrew one screw (①).
4. Remove the Rotation Spacer.

■ 6-2-30 Rotation Spacer (FRU No. 206) (continued)

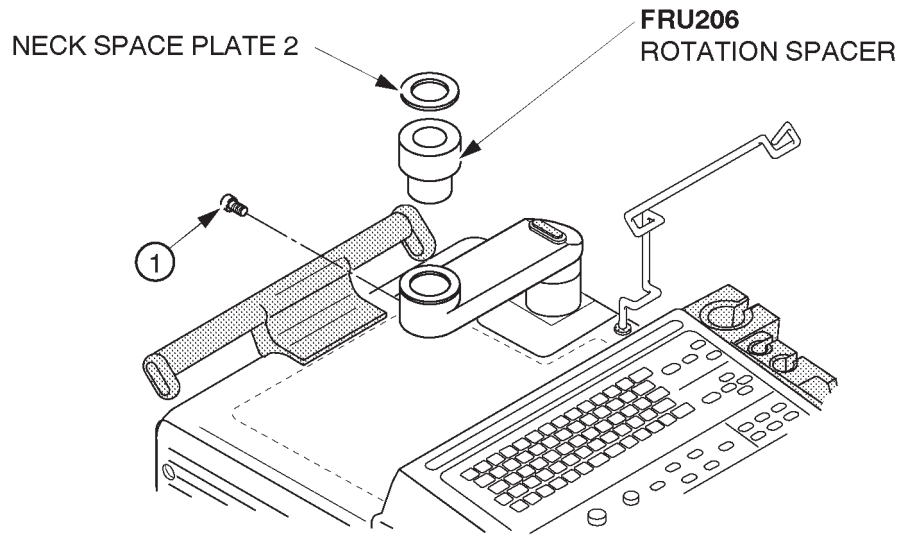

■ **ROTATION SPACER DISASSEMBLY**
ILLUSTRATION 6-52

This page is left blank intentionally.

6-2-31 Side Cover Left (FRU No. 301)**Time Required**

5 Minutes

Tool Required

Screwdriver

Procedure**Refer to ILLUSTRATION 6-53.**

1. Turn OFF the system.
2. Remove two screw caps (located at ③ and ④) and unscrew four screws (① – ④).
3. Remove the Side Cover Left.

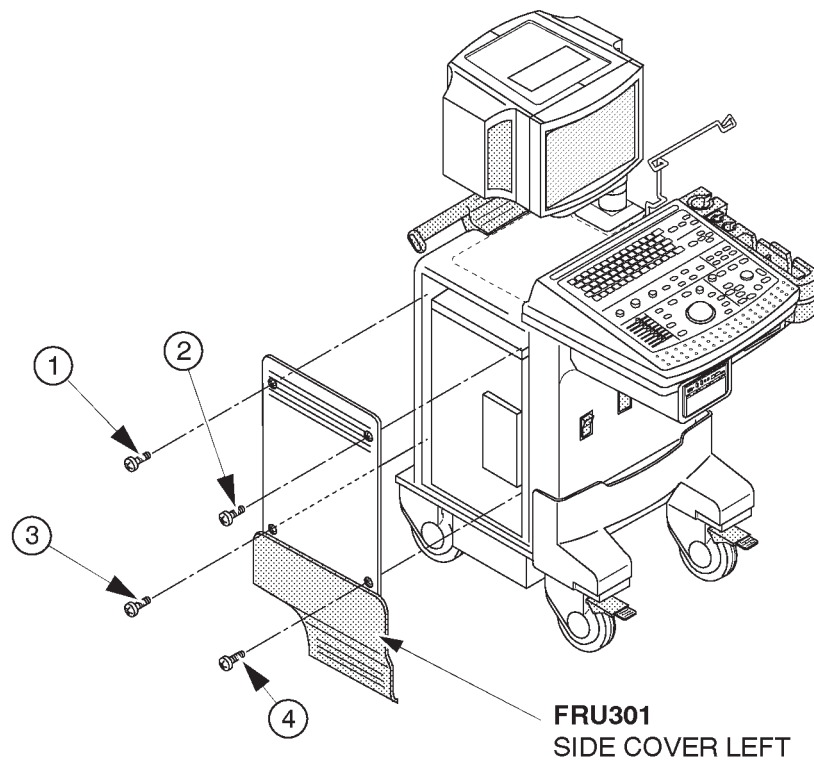

SIDE COVER LEFT DISASSEMBLY
ILLUSTRATION 6-53

■ 6-2-32 Side Cover Right (FRU No. 302)

Time Required

5 Minutes

Tool Required

Screwdriver

Procedure

■ Refer to ILLUSTRATION 6-54.

1. Turn OFF the system.
- 2. Remove the Front Base Cover (FRU No. 305). Refer to 6-2-35 on page 6-131.
3. Remove the two screw caps (located at ③ and ④) and unscrew five screws (① - ⑤).
- 4. Remove the Rear Door Assy. Refer to 6-2-34 on page 6-130.
5. Remove the Side Cover Right.

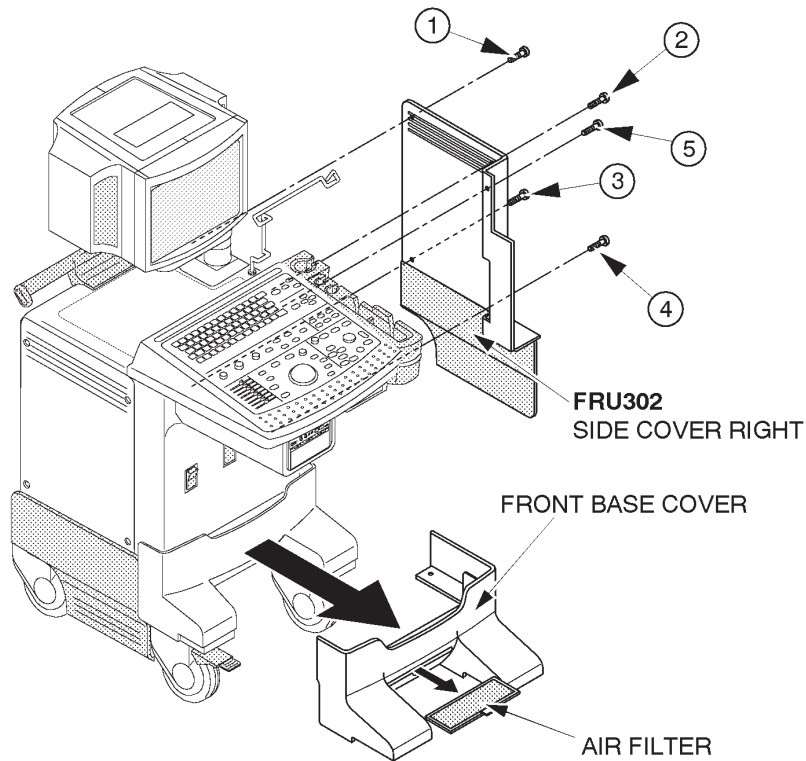

SIDE COVER RIGHT DISASSEMBLY

ILLUSTRATION 6-54

■ **6-2-33 Rear Cover (FRU No. 303)**

Time Required

15 Minutes

Tool Required

Screwdriver

Procedure

■ Refer to ILLUSTRATION 6-55.

1. Turn OFF the system.
2. Pull the Air Filter out.
- 3. Remove the Rear Door Assy. Refer to 6-2-34 on page 6-130.
4. Unscrew eight screws (① – ⑧).
5. Remove the Rear Cover.

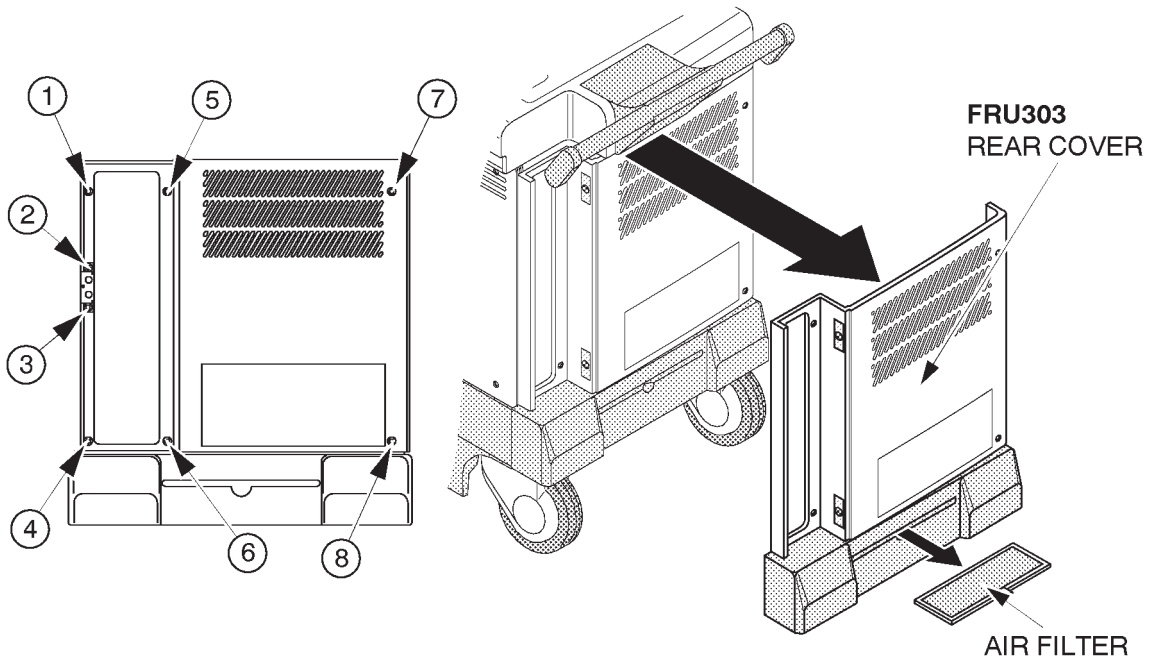

REAR COVER DISASSEMBLY
ILLUSTRATION 6-55



6-2-34 Rear Door Assy (FRU No. 304)**Time Required**

5 Minutes

Tool Required

Screwdriver

Procedure**Refer to ILLUSTRATION 6-56.**

1. Turn OFF the system.
2. Turn the knob on the Rear Door Assy counterclockwise.
3. Remove the Rear Door Assy.

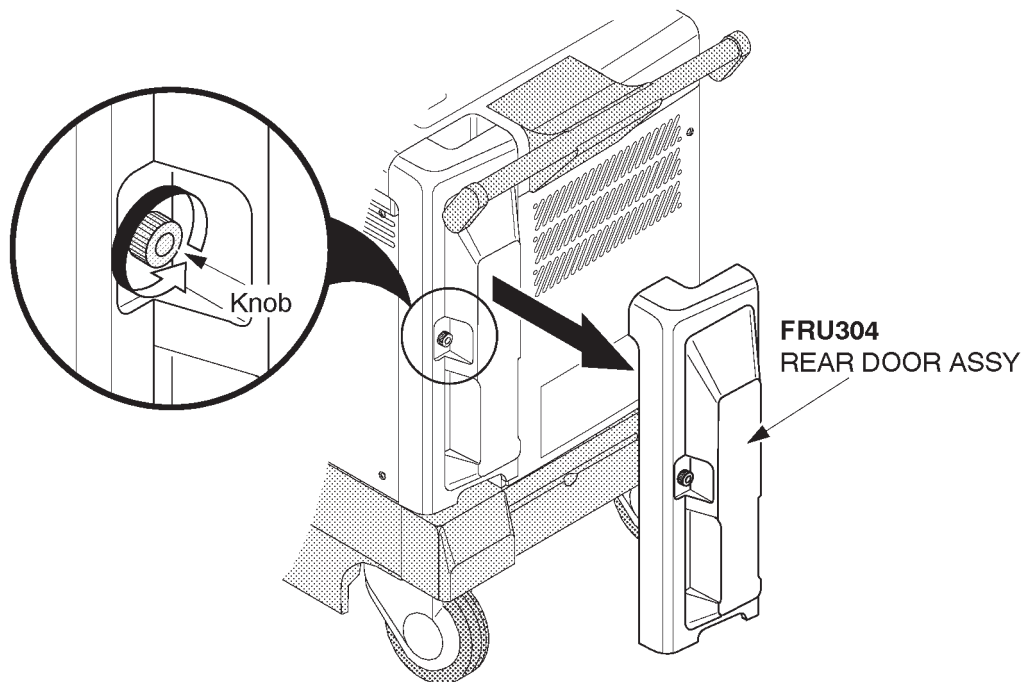

REAR DOOR ASSY DISASSEMBLY
ILLUSTRATION 6-56

■ **6-2-35 Front Base Cover (FRU No. 305)**

Time Required

5 Minutes

Tool Required

Screwdriver

Procedure

■ Refer to ILLUSTRATION 6-57.

1. Turn OFF the system.
2. Pull the Air Filter out.
3. Unscrew three screws (① – ③).
4. Remove the Front Base Cover.

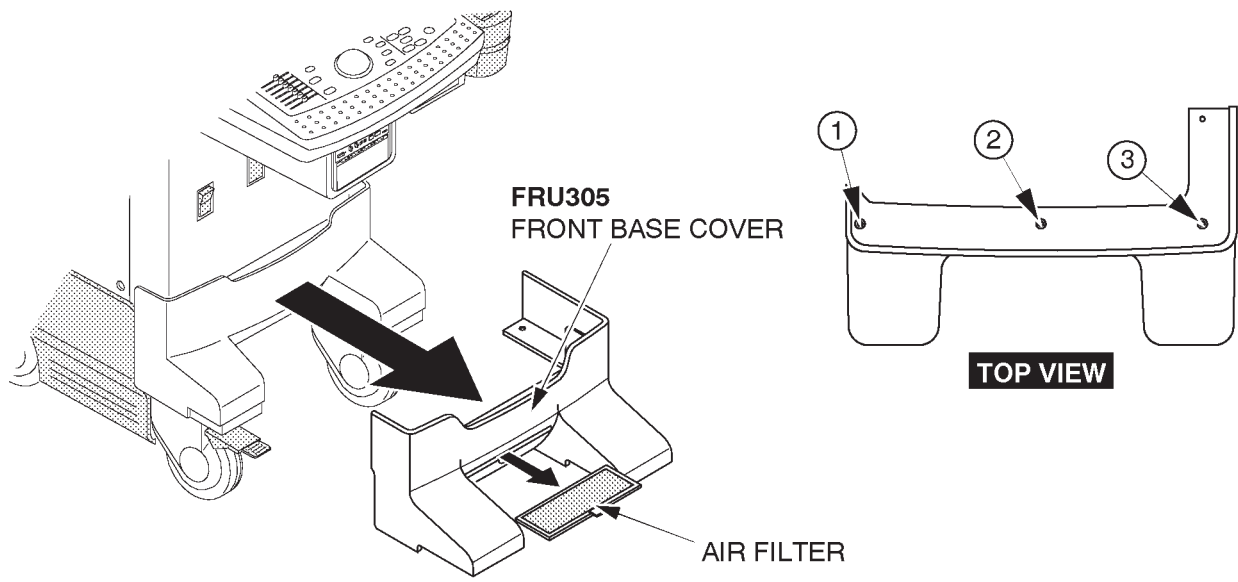

FRONT BASE COVER DISASSEMBLY
ILLUSTRATION 6-57

■

■ **6-2-36 Front Cover (FRU No. 306)**

Time Required

5 Minutes

Tool Required

Screwdriver

Procedure

■ Refer to ILLUSTRATION 6-58.

1. Turn OFF the system.
- 2. Remove the Front Base Cover (FRU No. 305). Refer to 6-2-35 on page 6-131.
3. Unscrew four screws (① – ④).
4. Remove the Front Cover.

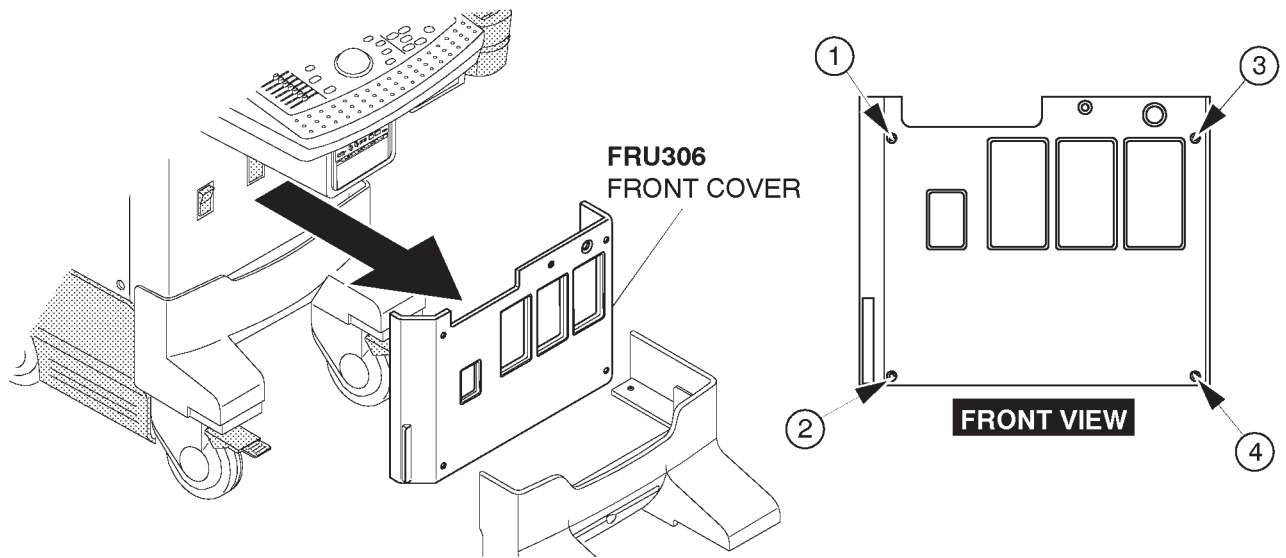

FRONT COVER DISASSEMBLY
ILLUSTRATION 6-58

■ 6-2-36 Front Cover (FRU No. 306)

Note

The Front Cover Assy (2211257) consists of the Front Cover (P9524CE) and the Blind Label. It is necessary to attach the Blind Label on the Front Cover to cover the openings for the HDD LED in case of the console with the new type of 3.5-inch HDD (Quantum™ FireBall™ 1280S). Because the new type of 3.5-inch HDD does not support the HDD LED function to indicate the access status of HDD. To attach the Blind Label to the Front Cover, refer to ILLUSTRATION 6-59.

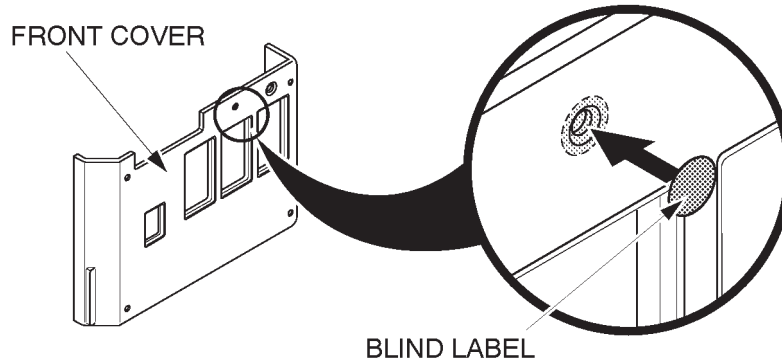

ATTACHING BLIND LABEL TO FRONT COVER
ILLUSTRATION 6-59

■ **6-2-37 Keyboard Bottom Cover (FRU No. 307)**

Time Required

20 Minutes

Tool Required

Screwdriver

Procedure

■ Refer to ILLUSTRATION 6-60.

1. Turn OFF the system.
2. Remove the Front Base Cover (FRU 305). Refer to 6-2-35 on page 6-131.
3. Remove the Front Cover (FRU 306). Refer to 6-2-36 on page 6-132.
4. Remove the Side Cover Right (FRU 302). Refer to 6-2-32 on page 6-128.
5. Unscrew six screws (① – ⑥).
6. Remove the Keyboard Bottom Cover.

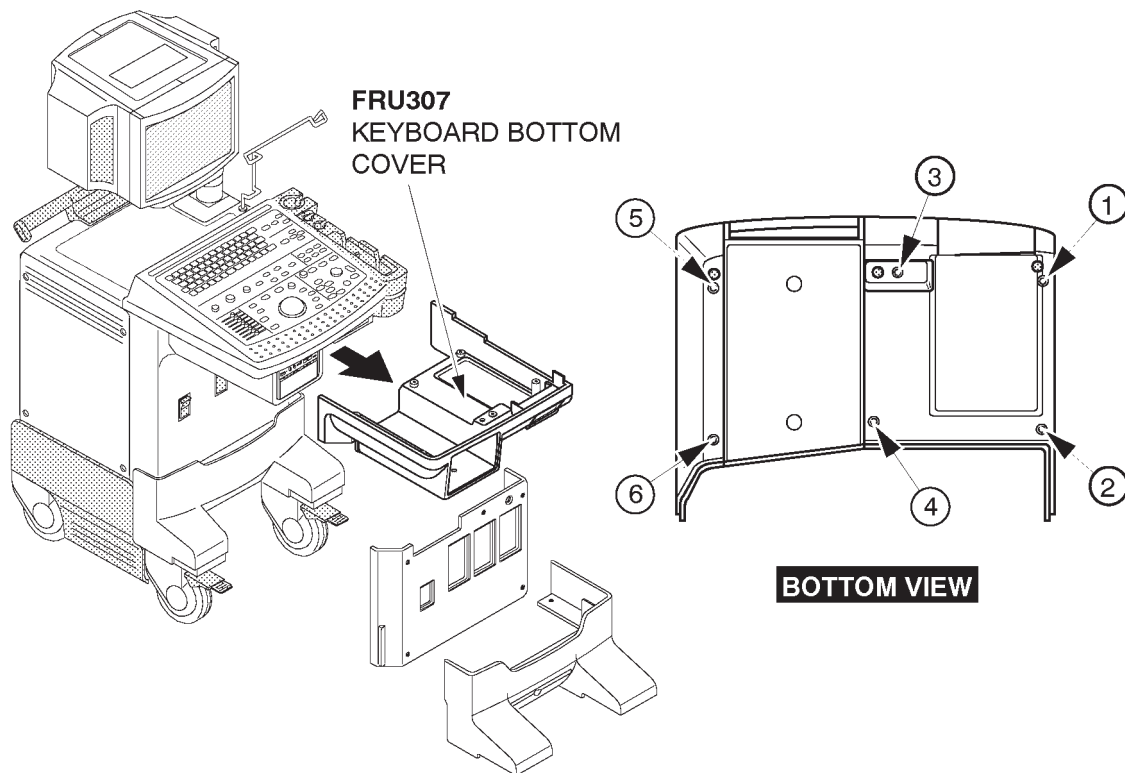

KEYBOARD BOTTOM COVER DISASSEMBLY
ILLUSTRATION 6-60

■ **6-2-38 Top Cover (FRU No. 308)**

Time Required

30 Minutes

Tool Required

Screwdriver

Procedure

■ Refer to ILLUSTRATION 6-61.

1. Turn OFF the system.
2. Remove the Top Cover Sheet.
3. Remove the Side Cover Left (FRU 301). Refer to 6-2-31 on page 6-127.
4. Remove the Side Cover Right (FRU 302). Refer to 6-2-32 on page 6-128.
5. Remove the Rear Cover Assy (FRU 303). Refer to 6-2-33 on page 6-129.
6. Pull the Cable Arm Assy out. Refer to 6-2-45 on page 6-142.
7. Unscrew two screws (①) and (②) from the upper side of top cover and five screws (③)–(⑦) from the lower side of top cover.
8. Remove the Top Cover.

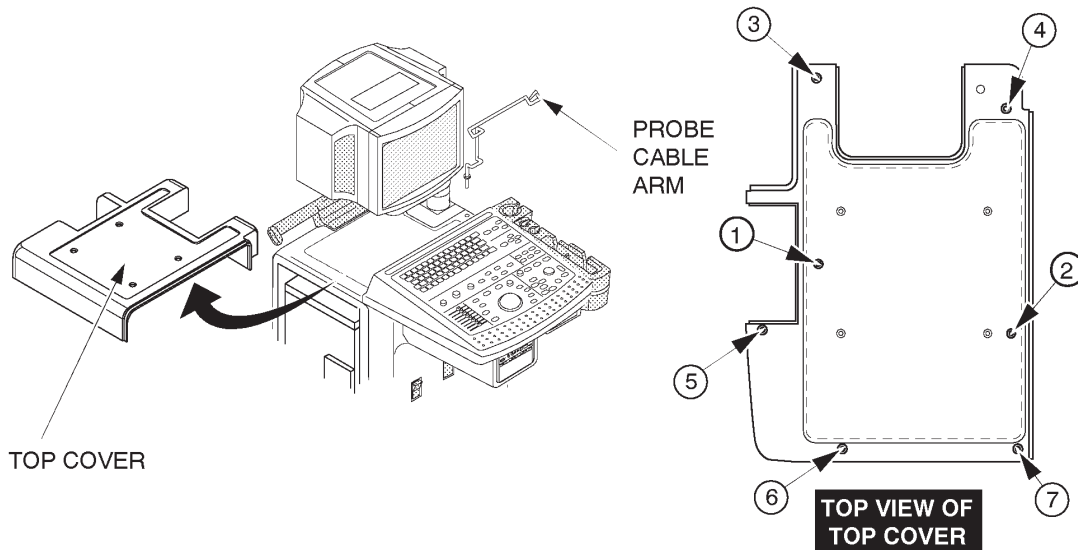

TOP COVER DISASSEMBLY
ILLUSTRATION 6-61

■ **6-2-39 Front Bumper Set (FRU No. 310)**

Time Required

10 Minutes

Tool Required

Screwdriver
Hexagonal Wrench

Procedure

- Refer to ILLUSTRATION 6-62.
- 1. Turn OFF the system.
- 2. Remove the Front Base Cover (FRU 305). Refer to 6-2-35 on page 6-131.
- 3. Unscrew three hexagonal bolts from each Caster Bumper (① – ③).
- 4. Remove the Front Bumpers.

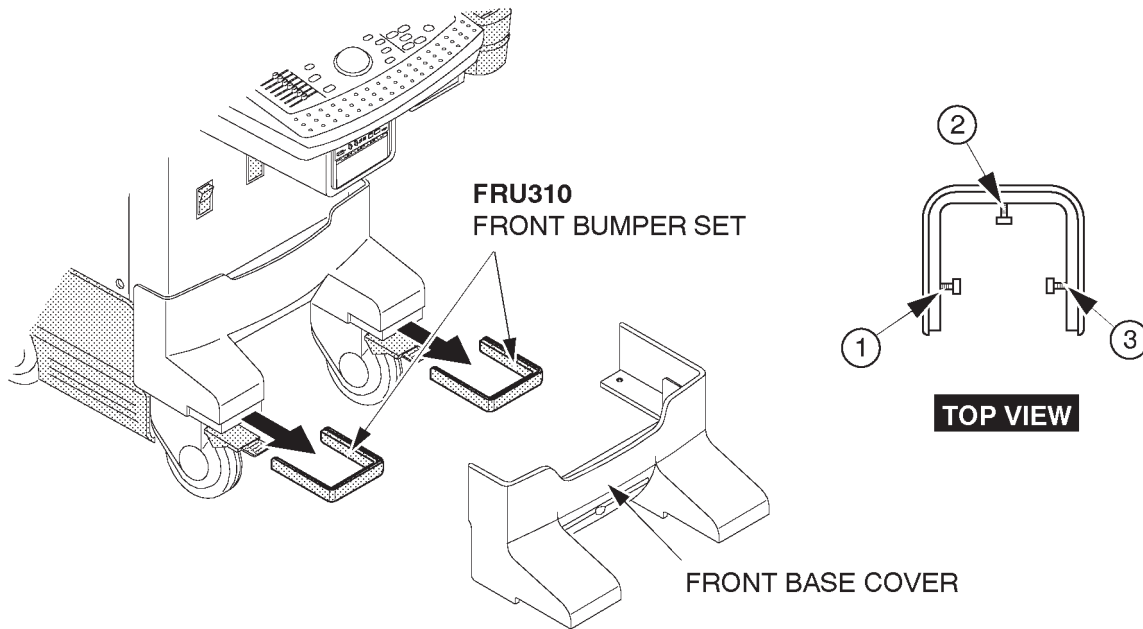

FRONT BUMPER SET DISASSEMBLY
ILLUSTRATION 6-62

Note

Reuse the hexagonal bolts removed to install the new front bumper(s).

Note

Tall version console is used the BUMPER LONG SET ASSY.

■ **6-2-40 Corner Guard (FRU No. 311)**

Time Required

10 Minutes

Tool Required

Screwdriver

Procedure

■ Refer to ILLUSTRATION 6-63.

1. Turn OFF the system.
- 2. Remove the Keyboard Panel Assy (FRU 400). Refer to 6-2-49 on page 6-147.
3. Unscrew inside three hexagonal bolts (① – ③).
4. Unscrew outside five screws (④ – ⑧).
5. Remove the Corner Guard upwards.

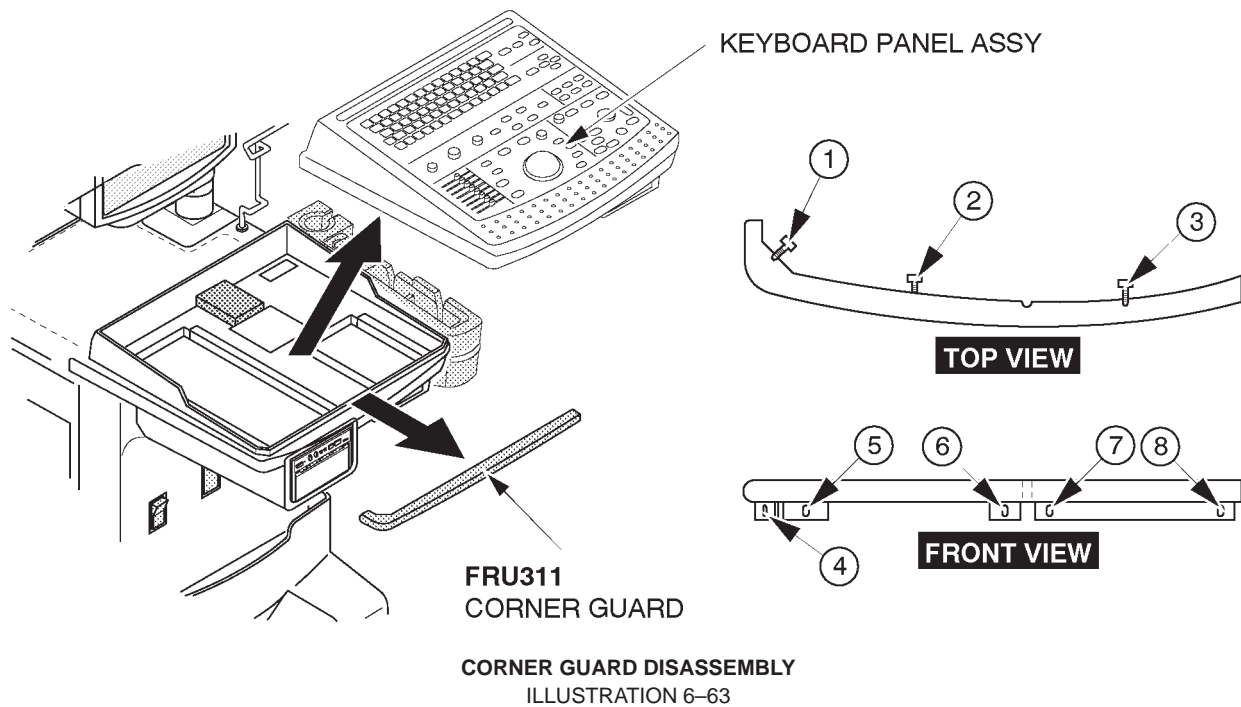

■

Note

Reuse the hexagonal bolts and screws removed to install the new corner guard.

6-2-41 Probe Holder (FRU No. 312)**Time Required**

1 Minutes

Tool Required

Not necessary

Procedure**Refer to ILLUSTRATION 6-64.**

1. Turn OFF the system.
2. Pull the latch located at bottom of the probe holder.
3. Pull the Probe Holder out.

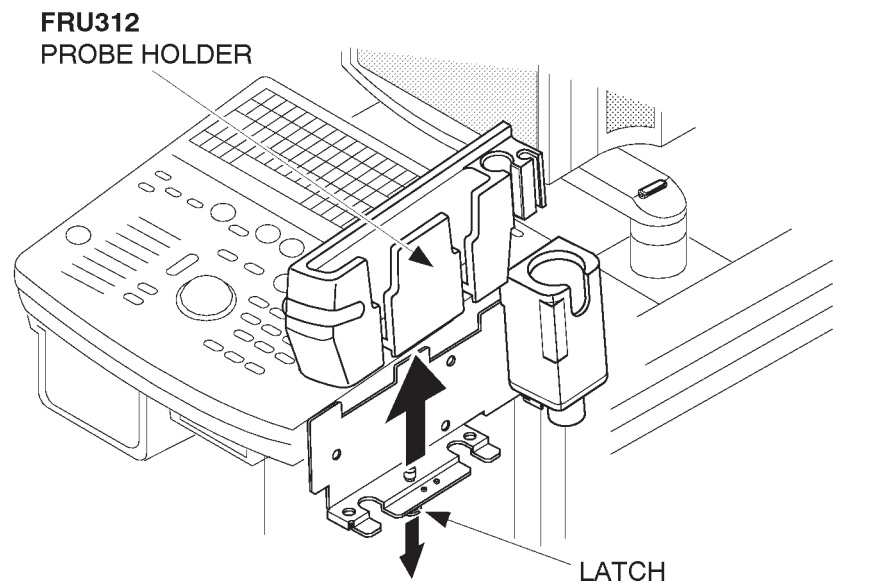

PROBE HOLDER REMOVAL
ILLUSTRATION 6-64

6-2-42 Gel Holder (FRU No. 313), Gel Holder Bottom (FRU No. 314)**Time Required**

1 Minutes

Tool Required

Not necessary

Procedure**Refer to ILLUSTRATION 6-65.**

1. Turn OFF the system.
2. Pull the Gel Holder out.
3. Remove the Gel Holder Bottom from the Gel Holder.

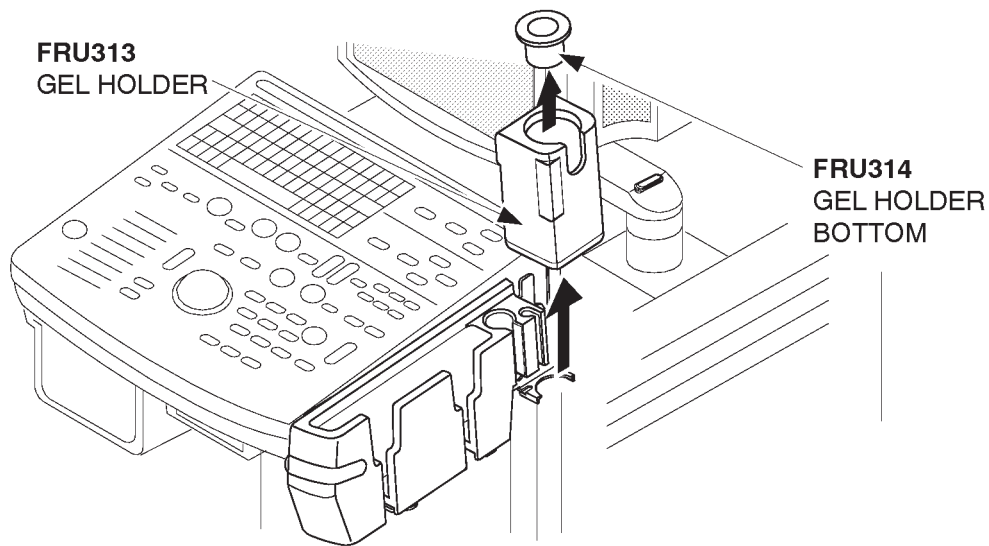

GEL HOLDER AND GEL HOLDER BOTTOM REMOVAL
ILLUSTRATION 6-65

■ **6-2-43 Handle (FRU No. 315)**

Time Required

15 Minutes

Tool Required

Screwdriver
Hexagonal Wrench

Procedure

- Refer to ILLUSTRATION 6-66.
- 1. Turn OFF the system.
- 2. Remove the Rear Cover (FRU No. 303). Refer to 6-2-33.
- 3. Unscrew four hexagonal bolts (① – ④).
- 4. Remove the Handle.

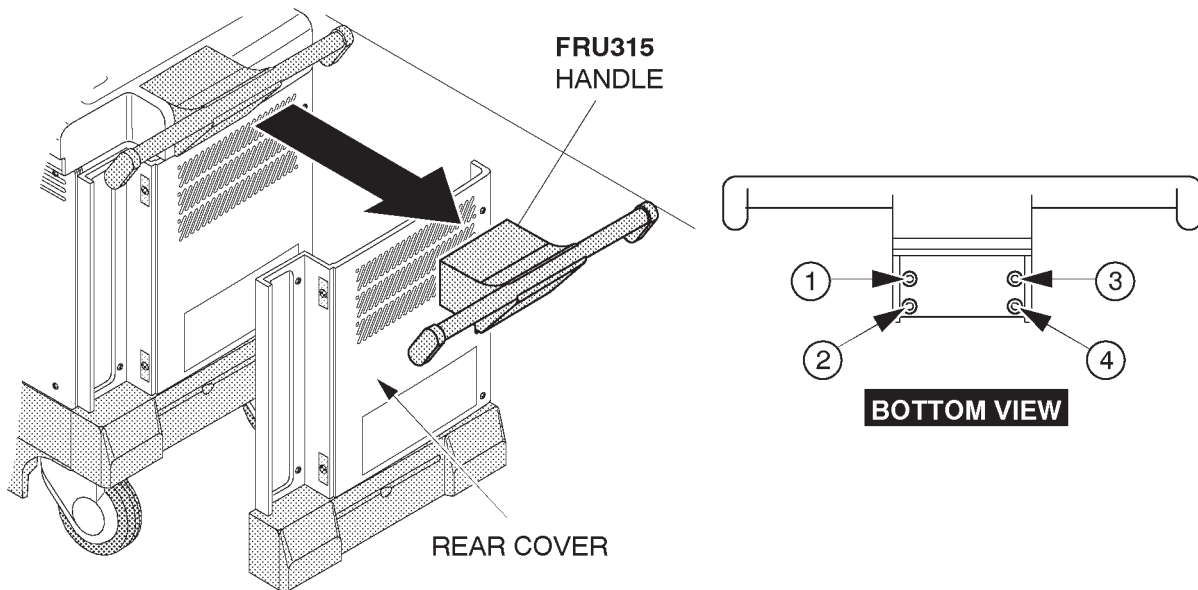

HANDLE DISASSEMBLY
ILLUSTRATION 6-66



■ **6-2-44 Air Filter (FRU No. 316)**

Time Required

5 Minutes

Tool Required

Not necessary

Procedure

■ Refer to ILLUSTRATION 6-67.

1. Turn OFF the system.
2. Pull out the two Air Filters (① and ②) located at front and rear of console.

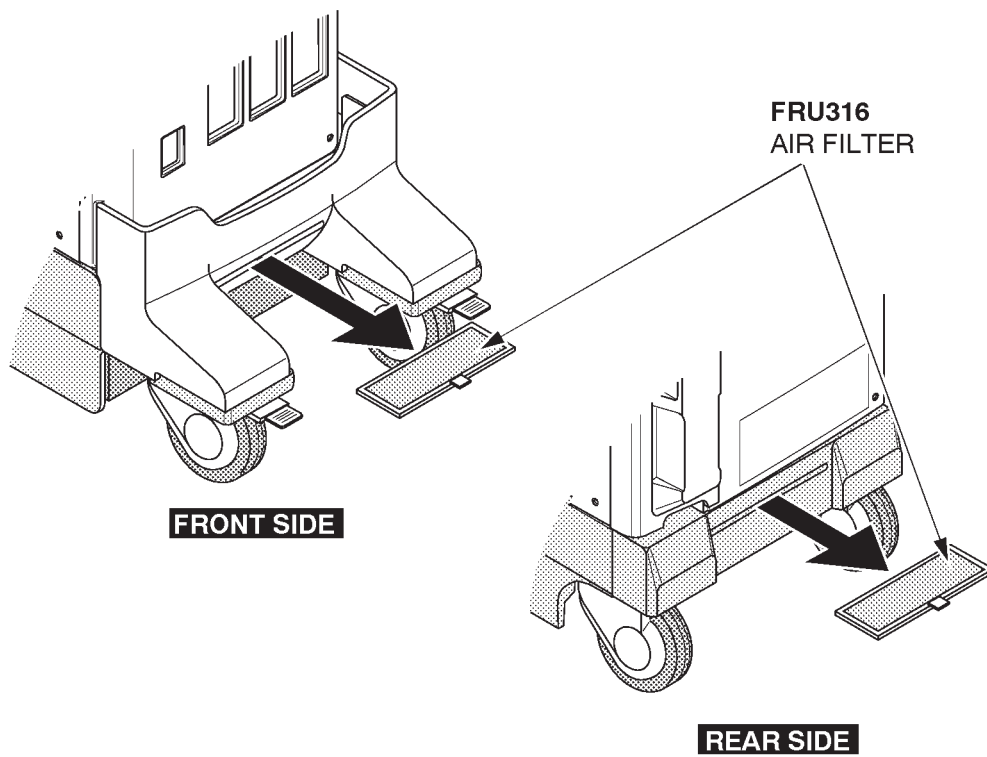

AIR FILTERS REMOVAL
ILLUSTRATION 6-67



6-2-45 Cable Arm Assy (FRU No. 317)**Time Required**

1 Minute

Tool Required

Not necessary

Procedure**Refer to ILLUSTRATION 6-68.**

1. Turn OFF the system.
2. Pull the Cable Arm Assy out.

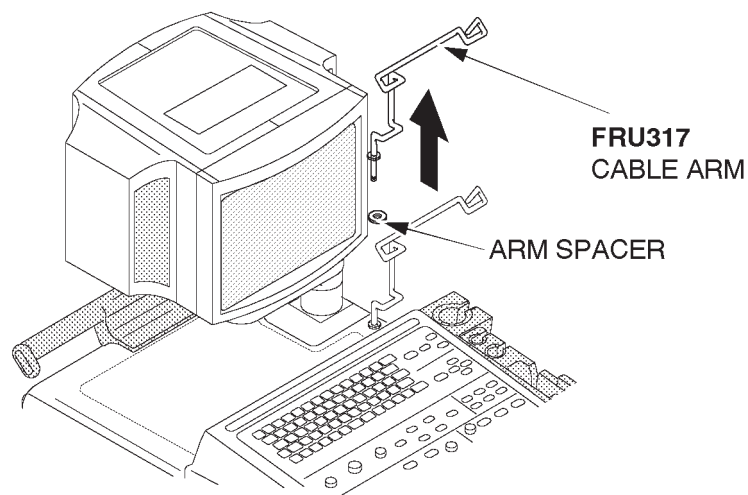

CABLE ARM REMOVAL
ILLUSTRATION 6-68

6-2-46 Front Caster Assy (FRU No. 318)**Time Required**

15 Minutes

Tool Required

Screwdriver

Hexagonal Wrench

Procedure**Refer to ILLUSTRATION 6-69.**

1. Turn OFF the system.
2. Put the system on a box.
3. Unscrew four hexagonal bolts (① – ④).
4. Remove the Front Caster Assy.

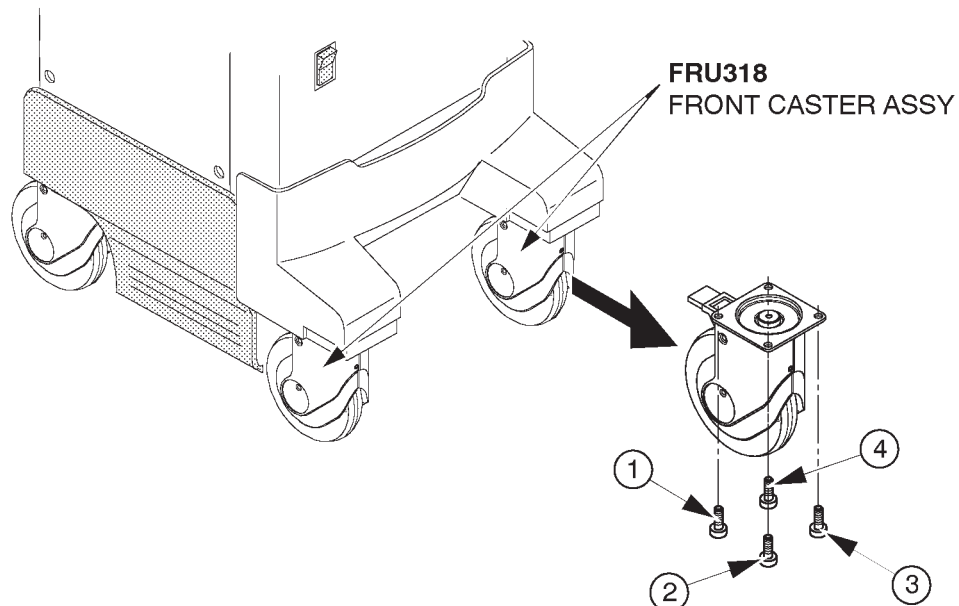

FRONT CASTER ASSY DISASSEMBLY
ILLUSTRATION 6-69

6-2-47 Rear Caster Assy (FRU No. 319)**Time Required**

15 Minutes

Tool Required

Screwdriver

Hexagonal Wrench

Procedure**Refer to ILLUSTRATION 6-70.**

1. Turn OFF the system.
2. Put the system on a box.
3. Unscrew four screws (① – ④).
4. Remove the Rear Caster Assy.

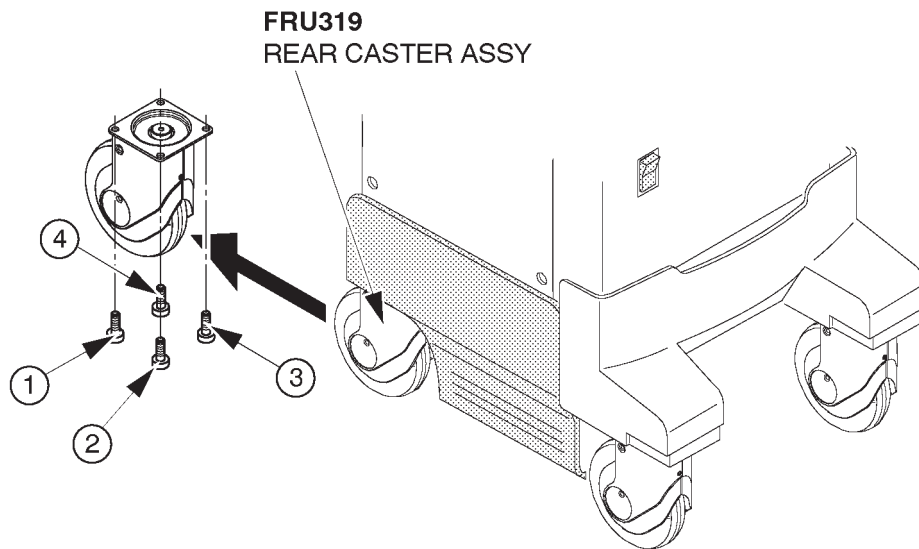

REAR CASTER DISASSEMBLY
ILLUSTRATION 6-70

6-2-48 Caster Cover Assy (FRU No. 320)**Time Required**

20 Minutes

Tool Required

Screwdriver

Procedure**Refer to ILLUSTRATION 6-71.**

1. Turn OFF the system.
2. Remove four labels, two for Logo and two for plain.
3. Unscrew five screws (① – ⑤).
4. Remove the Caster Cover Assy.

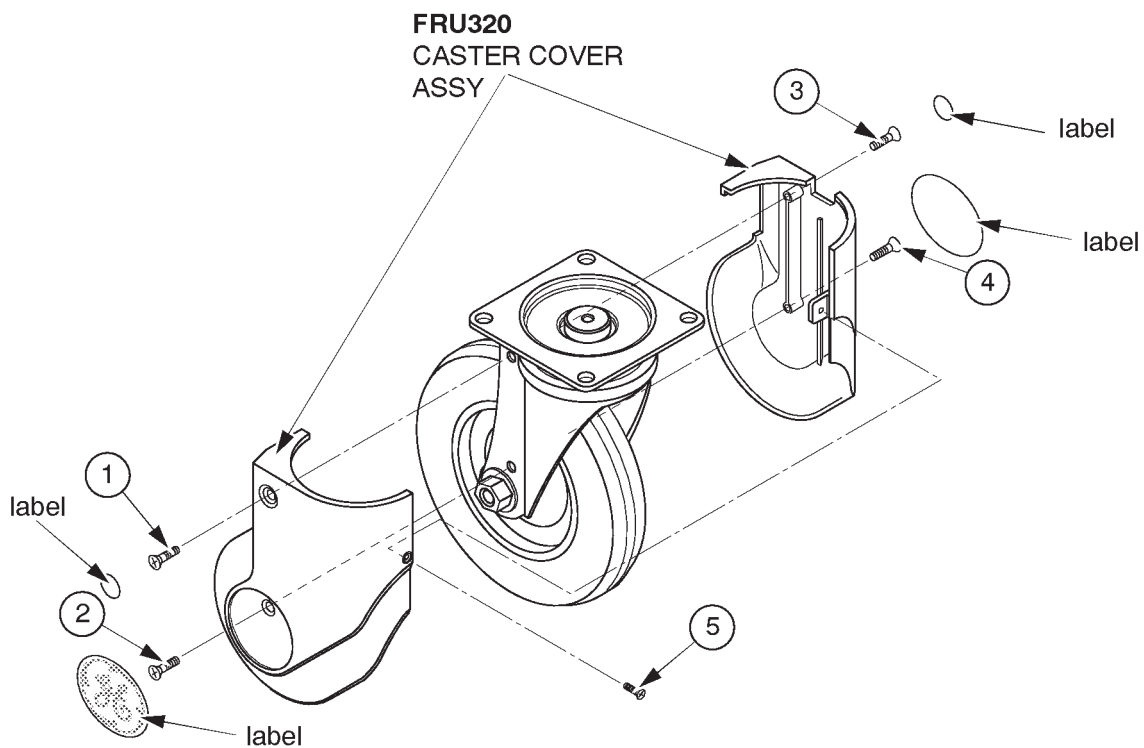

CASTER COVER ASSY DISASSEMBLY
ILLUSTRATION 6-71

This page is left blank intentionally.

■ **6-2-49 Keyboard Panel Assy (FRU No. 400)**

Time Required

8 Minutes

Tool Required

Screwdriver

Procedure

■ Refer to ILLUSTRATION 6-72.

1. Turn OFF the system.
2. Unscrew three screws (① – ③) of the Keyboard Panel Assy.
3. Lift the Keyboard Assy up.
4. Disconnect the connector (④).
5. Remove the Keyboard Panel Assy.

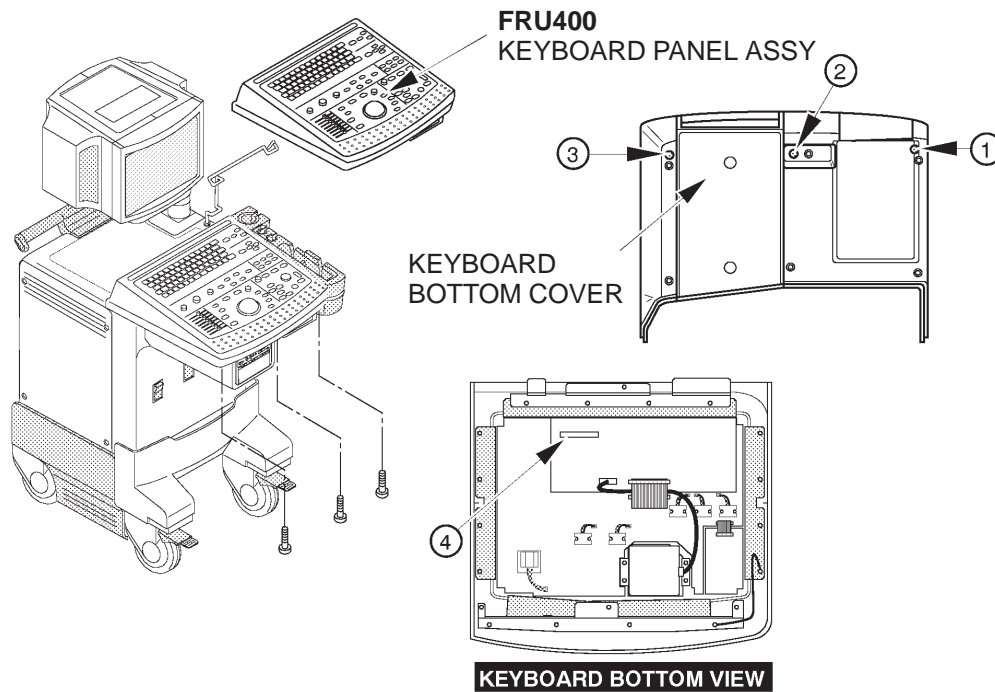

KEYBOARD PANEL ASSY DISASSEMBLY
ILLUSTRATION 6-72

Note

The color of the Key Sheet for the LOGIQ™ 400CL is different from the other color monitor assy. Use the proper FRU when replacing the Keyboard Panel Assy for the LOGIQ™ 400CL.

6–2–50 Keyboard Assy (FRU No. 401), Keyboard Cover (FRU No. 402), Key Sheet (FRU No. 403)**Time Required**

30 Minutes

Tool Required

Screwdriver

Hexagonal Wrench

Procedure

- Refer to ILLUSTRATION 6–73 on page 6–149.
 1. Turn OFF the system.
 - 2. Remove six encoder knobs and eight TGC knobs. Refer to ILLUSTRATION 6–79 on page 6–159.
 - 3. Remove the Keyboard Panel Assy. Refer to 6–2–49 on page 6–147.
 4. Unscrew nine screws (① – ⑨) to remove two metal plates.
 5. Unscrew ten screws (⑩ – ⑲).
 6. Remove the Keyboard Cover (FRU 402).
 7. Unscrew twelve screws (⑳ – ㉳).
 8. Remove the Key Sheet (FRU 403) out of the Keyboard Assy or the Keyboard Panel2 Assy (FRU 401).

Note

The color of the Key Sheet for the LOGIQ™ 400CL is different from the other color monitor assy. Use the proper FRU when replacing the Key Sheet for the LOGIQ™ 400CL.

6-2-50 Keyboard Assy (FRU No. 401), Keyboard Cover (FRU No. 402), Key Sheet (FRU No. 403)
(continued)

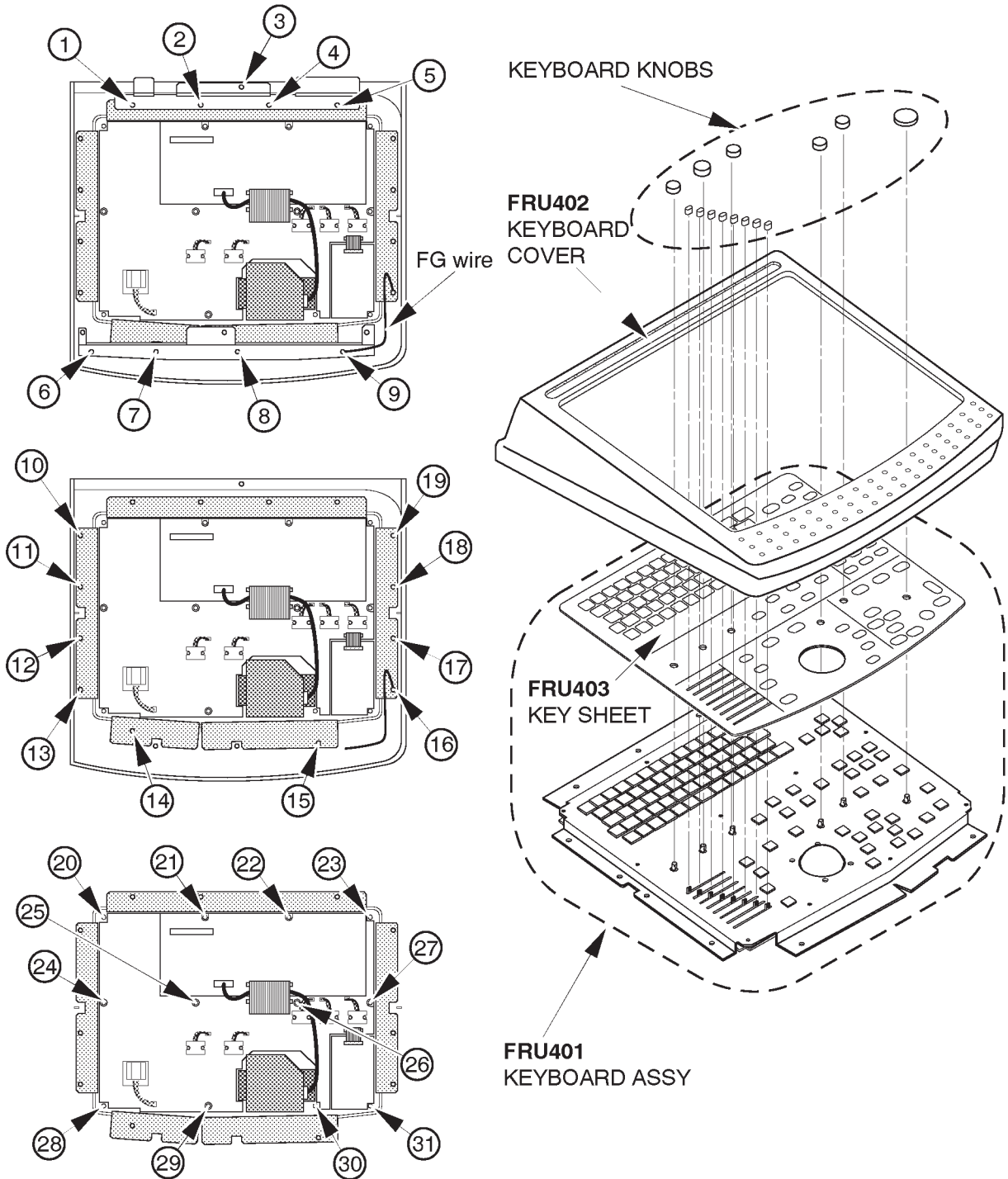

KEYBOARD ASSY, KEYBOARD COVER AND KEY SHEET DISASSEMBLY

ILLUSTRATION 6-73

This page is left blank intentionally.

■ **6-2-51 Keyboard Knob Set (FRU No. 404)**

Time Required

20 Minutes

Tool Required

Hexagonal Wrench

Procedure

■ Refer to ILLUSTRATION 6-74.

1. Turn OFF the system.
2. Loosen two hexagonal bolts for each encoder knob.
3. Remove six Encoder Knobs (① – ⑥).
4. Pull the eight TGC Pot Knobs (⑦) out

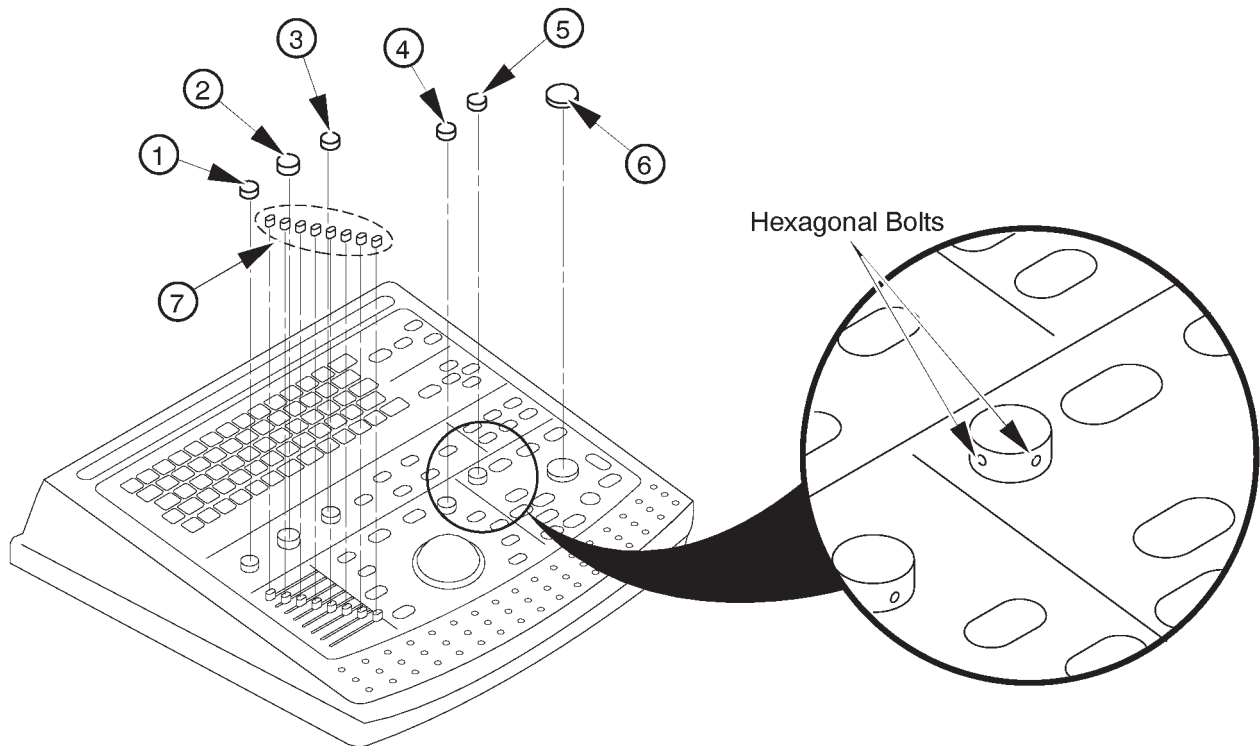

KEYBOARD KNOBS DISASSEMBLY

ILLUSTRATION 6-74

6-2-52 Trackball (FRU No. 405)

Time Required

20 Minutes

Tool Required

Screwdriver

Procedure

Refer to ILLUSTRATION 6-75.

1. Turn OFF the system.
2. Remove the Keyboard Panel Assy. Refer to 6-2-49 on page 6-147.
3. Unscrew four screws (① – ④).
4. Disconnect one connector (⑤).
5. Unscrew four screws (⑥ – ⑨).
6. Remove The Holding Metal Plate.

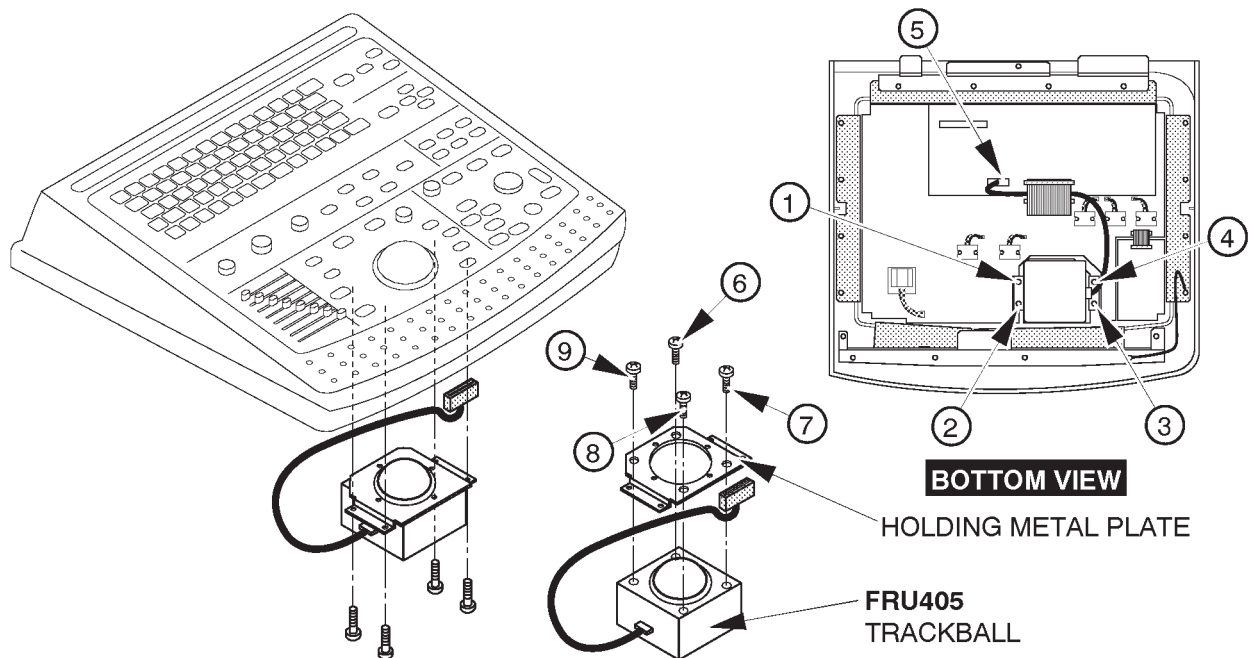

TRACKBALL DISASSEMBLY
ILLUSTRATION 6-75

6-2-53 Gain Encoder (FRU No. 410)

Time Required

15 Minutes

Tool Required

Screwdriver

Procedure

- Refer to ILLUSTRATION 6-76.
- 1. Turn OFF the system.
- 2. Remove the Keyboard Panel Assy. Refer to 6-2-49 on page 6-147.
- 3. Unscrew four screws (① – ④).
- 4. Disconnect the gain encoder connector (⑤).

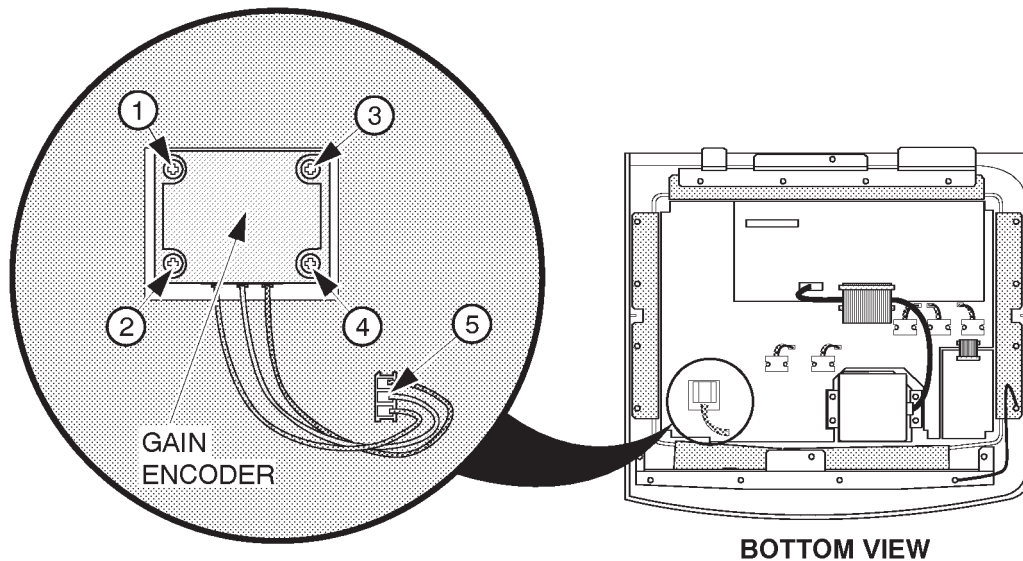

GAIN ENCODER DISASSEMBLY
ILLUSTRATION 6-76

Note

The appearance of new Gain Encoder (2206005) is different from the old one (2164871).

Note

The new Gain Encoder (2206005) can be used only for the console with the software version 3.30 or later.

This page is left blank intentionally.

6-2-54 Keyboard Panel Assy (FRU No. 450)

Time Required

8 Minutes

Tool Required

Screwdriver

Procedure

Refer to ILLUSTRATION 6-77.

1. Turn OFF the system.
2. Unscrew three screws (① – ③) of the Keyboard Panel Assy.
3. Lift the Keyboard Assy up.
4. Disconnect the connector (④).
5. Remove the Keyboard Panel Assy.

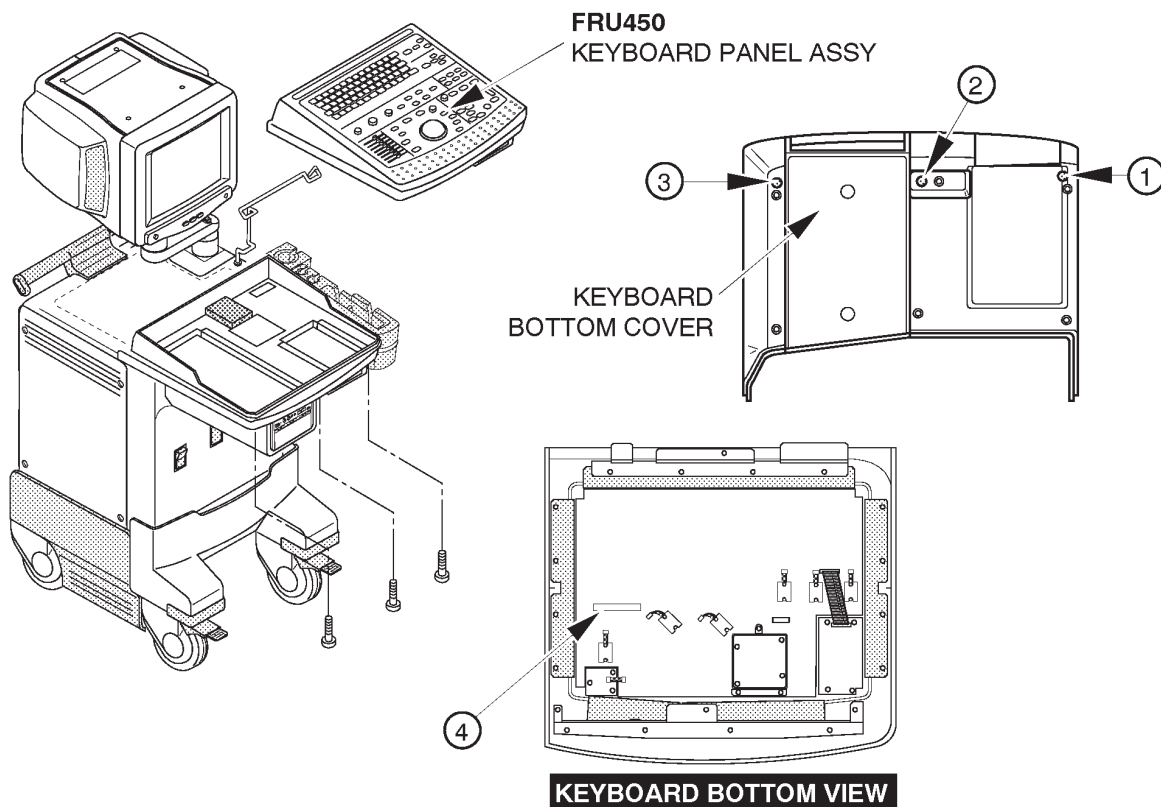

KEYBOARD PANEL ASSY DISASSEMBLY
ILLUSTRATION 6-77

Note

The color of the Keyboard Panel for the LOGIQ™ 400CL is different from the other color monitor assy. Use the proper FRU when replacing the Keyboard Panel Assy for the LOGIQ™ 400CL.

**6–2–55 Keyboard Cover Assy (FRU No. 451), SW PWB (FRU No. 462),
Rubber Key (FRU No. 452, 453, 454, and 455)**

Time Required

30 Minutes

Tool Required

Screwdriver

Hexagonal Wrench

Procedure

Refer to ILLUSTRATION 6–78 on page 6–157.

1. Turn OFF the system.
2. Remove six encoder knobs and eight TGC knobs. Refer to ILLUSTRATION 6–79 on page 6–159.
3. Remove the Keyboard Panel Assy. Refer to ILLUSTRATION 6–77 on page 6–155.
4. Unscrew twenty seven screws (① –②⑦).
4. Remove nine connectors (②⑧–③⑥).
6. Remove the SW PWD Assy (FRU 462).
7. Remove the Rubber Key Assy (FRU 452, 453, 454 and 455).

Note

The color of the Key Sheet for the LOGIQ™ 400CL is different from the other color monitor assy. Use the proper FRU when replacing the Key Sheet for the LOGIQ™ 400CL.

Note

There are 4 type of Rubber key AN Assy depend on the support Language. Use the proper Rubber key AN Assy for using the Language.

6-2-55 Keyboard Cover Assy (FRU No. 451), SW PWB (FRU No. 462),
Rubber Key (FRU No. 452, 453, 454, and 455) (continued)

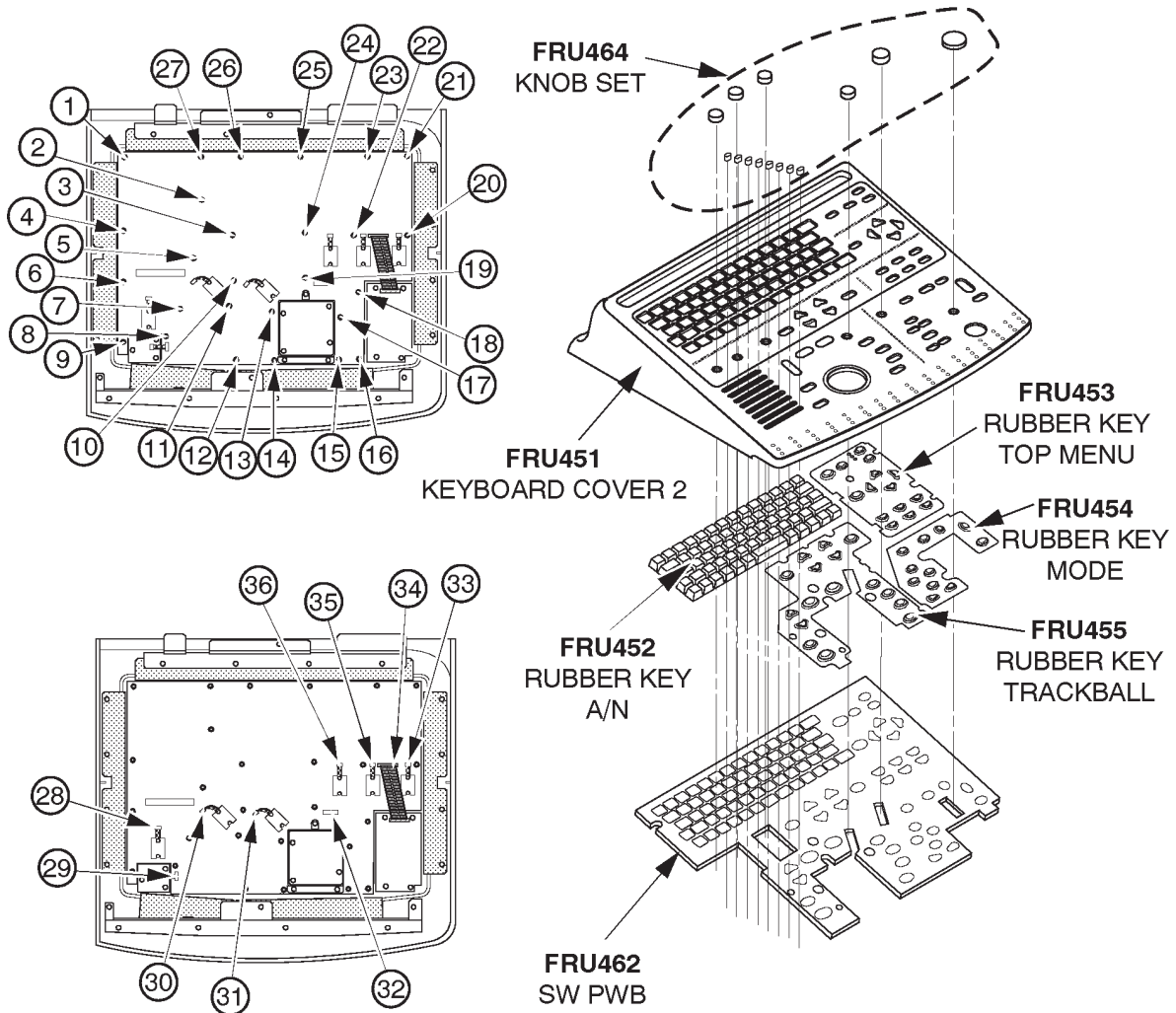

KEYBOARD ASSY, SW PWB, RUBBER KEY DISASSEMBLY
ILLUSTRATION 6-78

This page is left blank intentionally.

6-2-56 Keyboard Knob Set (FRU No. 464)

Time Required

20 Minutes

Tool Required

Hexagonal Wrench

Procedure

Refer to ILLUSTRATION 6-79.

1. Turn OFF the system.
2. Loosen two hexagonal bolts for each encoder knob.
3. Remove six Encoder Knobs (① – ⑥).
4. Pull the eight TGC Pot Knobs (⑦) out

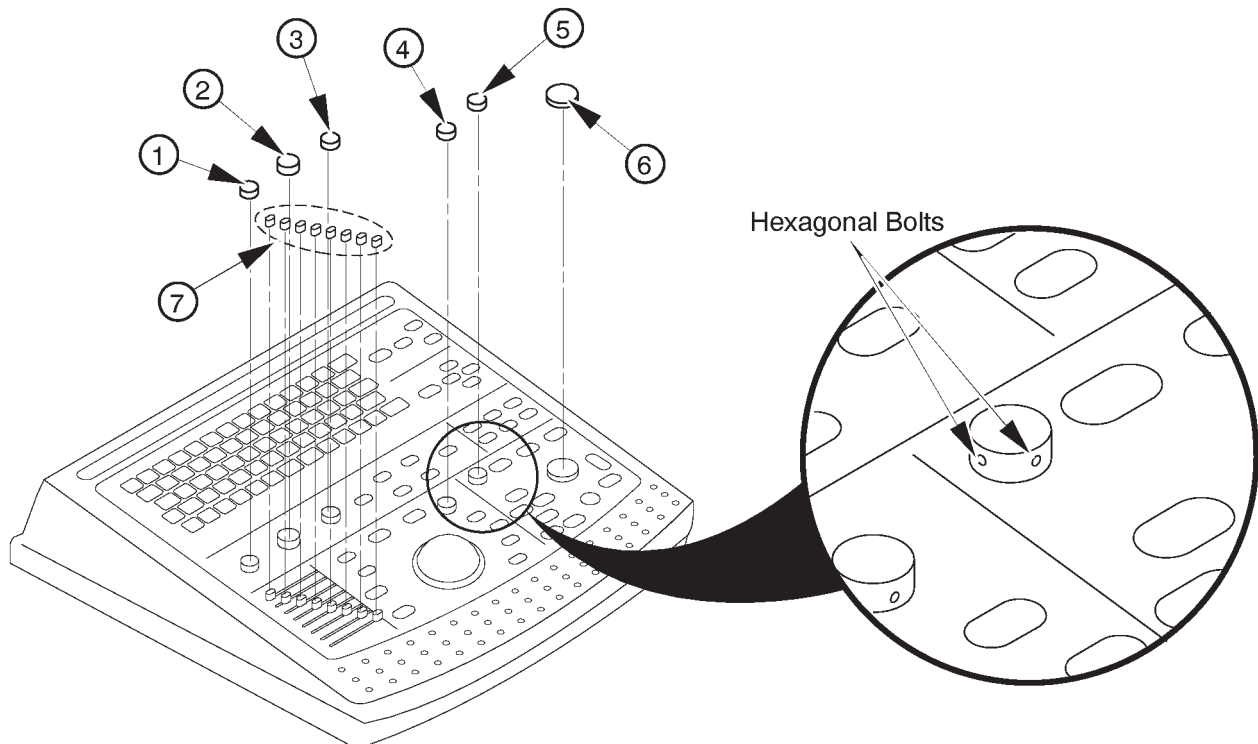

KEYBOARD KNOBS DISASSEMBLY
ILLUSTRATION 6-79

6-2-57 Tracball Assy (FRU No. 457)

Time Required

20 Minutes

Tool Required

Screwdriver

Procedure

Refer to ILLUSTRATION 6-80.

1. Turn OFF the system.
2. Remove the Keyboard Panel Assy. Refer to ILLUSTRATION 6-77 on page 6-155.
3. Unscrew four screws (① - ③).
4. Disconnect one connector (④).
5. Unscrew four screws (⑤ - ⑧).
6. Remove The Holding Metal Plate.

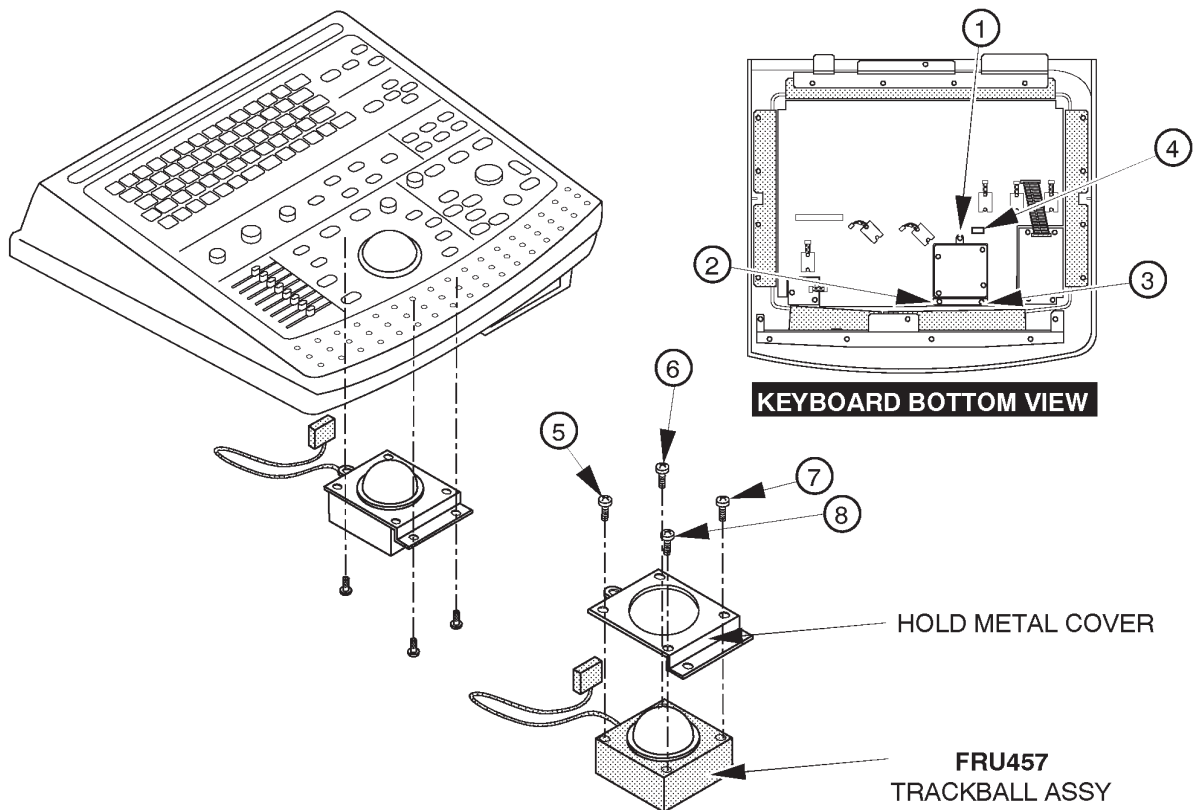

TRACKBALL DISASSEMBLY
ILLUSTRATION 6-80

6-2-58 TGC Assy (FRU No. 458)

Time Required

20 Minutes

Tool Required

Screwdriver

Procedure

Refer to ILLUSTRATION 6-81.

1. Turn OFF the system.
2. Remove the Keyboard Panel Assy. Refer to ILLUSTRATION 6-77 on page 6-155.
3. Unscrew four screws (① – ④).
4. Disconnect one connector (⑤).

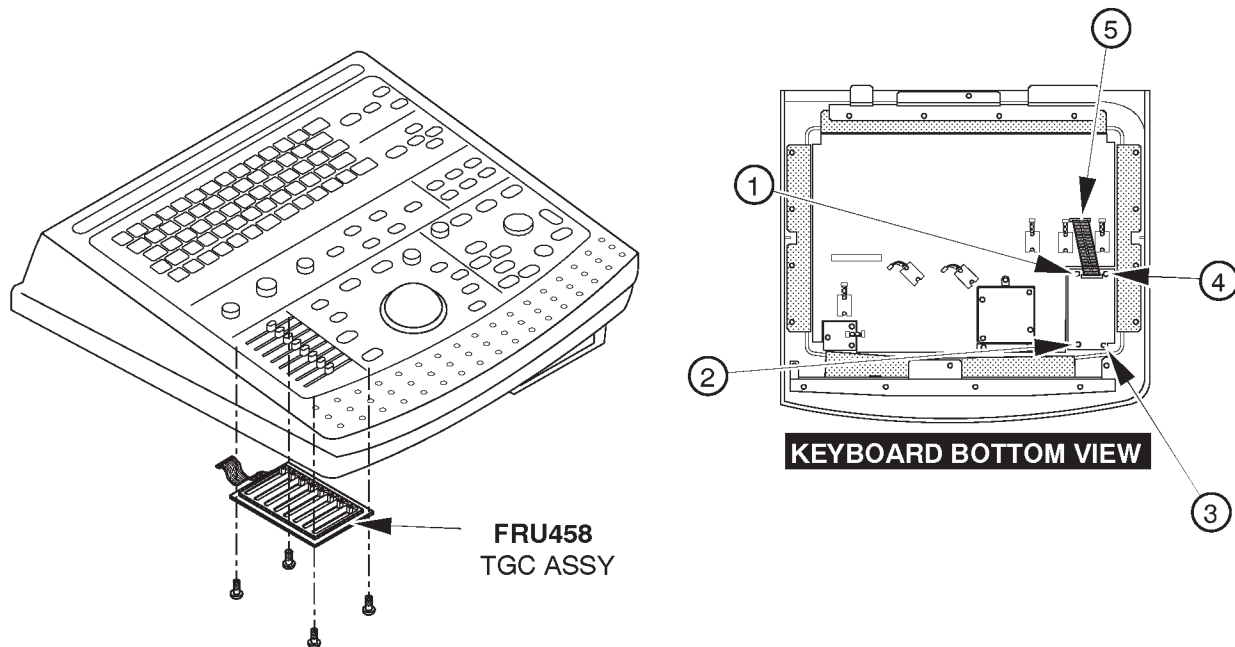

TGC DISASSEMBLY
ILLUSTRATION 6-81

6-2-59 Freeze Key Assy (FRU No. 459)

Time Required

20 Minutes

Tool Required

Screwdriver

Procedure

Refer to ILLUSTRATION 6-82.

1. Turn OFF the system.
2. Remove the Keyboard Panel Assy. Refer to ILLUSTRATION 6-77 on page 6-155.
3. Unscrew four screws (① – ③).
4. Disconnect one connector (④).
5. Remove The Holding Metal Plate.

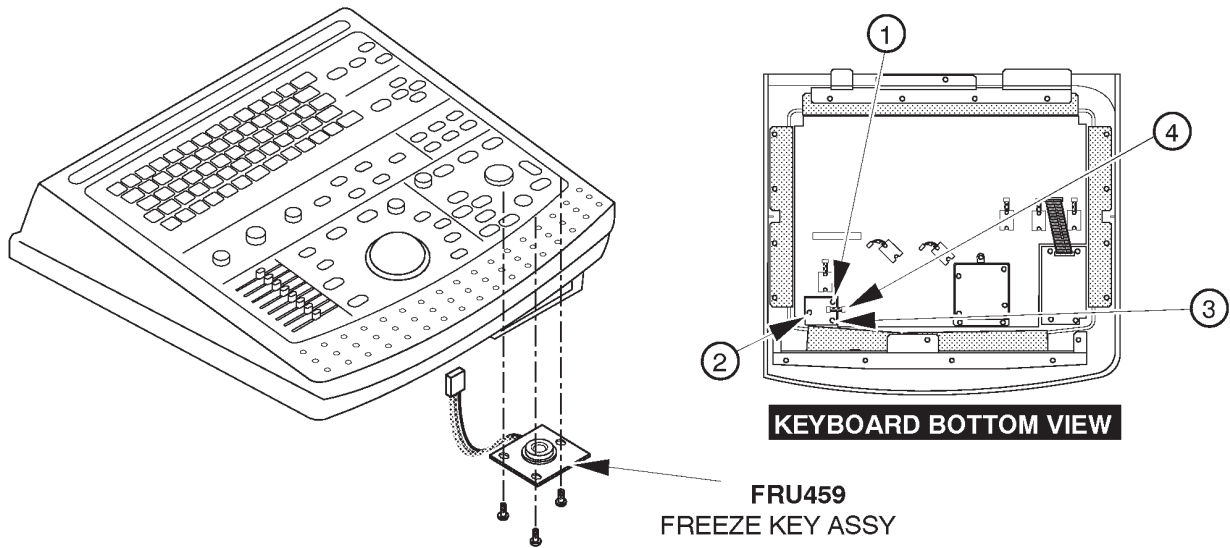

FREEZE KEY ASSY DISASSEMBLY
ILLUSTRATION 6-82

6-2-60 Rotary Encoder (FRU No. 460)

Time Required

15 Minutes

Tool Required

Screwdriver

Procedure

Refer to ILLUSTRATION 6-83.

Note

The same four rotary encoders are used in the keyboard Panel Assy.

1. Turn OFF the system.
2. Remove the Keyboard Panel Assy. Refer to ILLUSTRATION 6-77 on page 6-155.
3. Unscrew four screws (① – ②).
4. Disconnect the gain encoder connector (③).

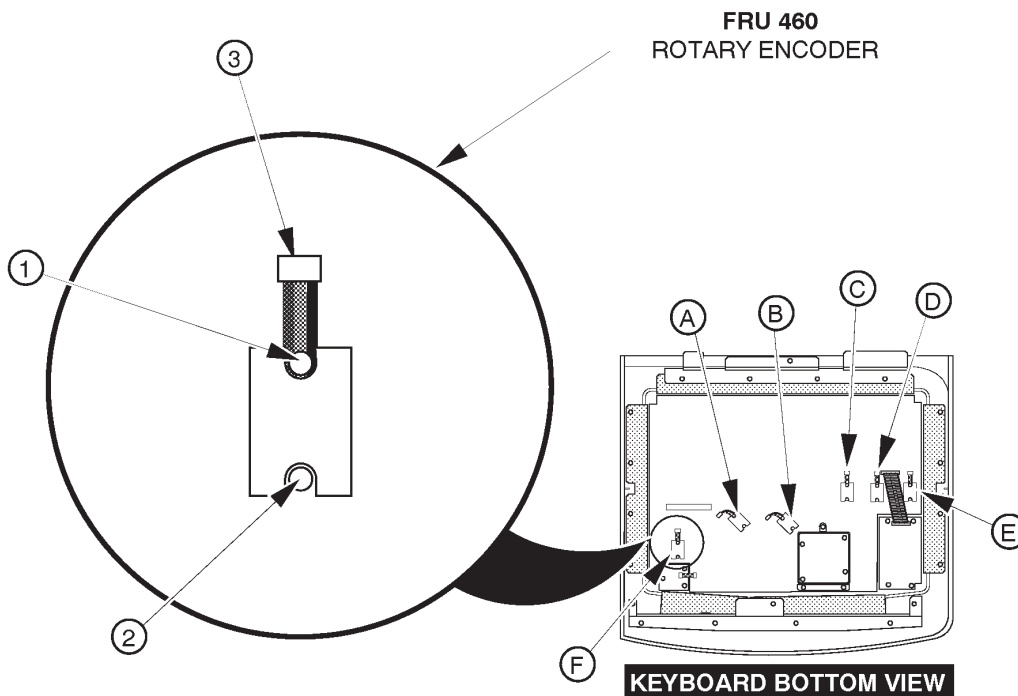

ROTARY ENCODER DISASSEMBLY
ILLUSTRATION 6-83

This page is left blank intentionally.

This page is left blank intentionally.

6-2-61 Rear CONN Panel Assy (FRU No. 501)

Time Required

20 Minutes

Tool Required

Screwdriver

Procedure

Refer to ILLUSTRATION 6-85 on page 6-167.

1. Turn OFF the system.
2. Remove the Rear Door Assy (FRU 304). Refer to 6-2-34 on page 6-130.
3. Remove the Rear Cover Assy (FRU 303). Refer to 6-2-33 on page 6-129.

Note

The Linear Slide Cover is installed from the production unit of LOGIQ™400 console with software Version 5.01y or later. Refer to ILLUSTRATION 6-48 on page 6-116. Remove the Linear Slide Cover.

Note

Unscrew the two screws (① and ②) to remove the Rear CONN Spacer. Refer to ILLUSTRATION 6-84. The Rear CONN Spacer is installed from the production unit of LOGIQ™400 console with software Version 5.01y or later.

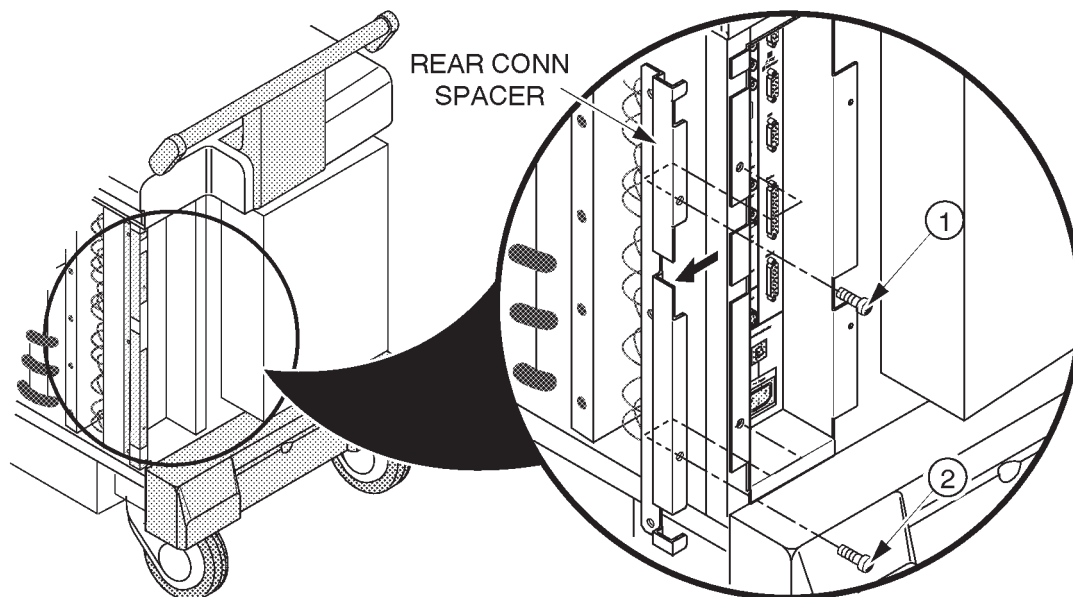

REAR CONN SPACER DISASSEMBLY

ILLUSTRATION 6-84

6-2-61 Rear CONN Panel Assy (FRU No. 501) (continued)

4. Unscrew three screws (① – ③).
5. Loosen one screw (④).
6. Disconnect one flat cable (⑤) out of the CNTIF Assy or CNTIF2 Assy.

Note

The CNTIF2 Assy includes the Ethernet port for the DICOM option.

7. Disconnect one flat cable (⑥) out of the AVIF Assy or BVIF Assy.
8. Disconnect two connectors (⑦ and ⑧). One of them is connected with the Power Supply Unit, and another is connected with the B/W Printer Panel.
9. Remove the Rear CONN Panel Assy.

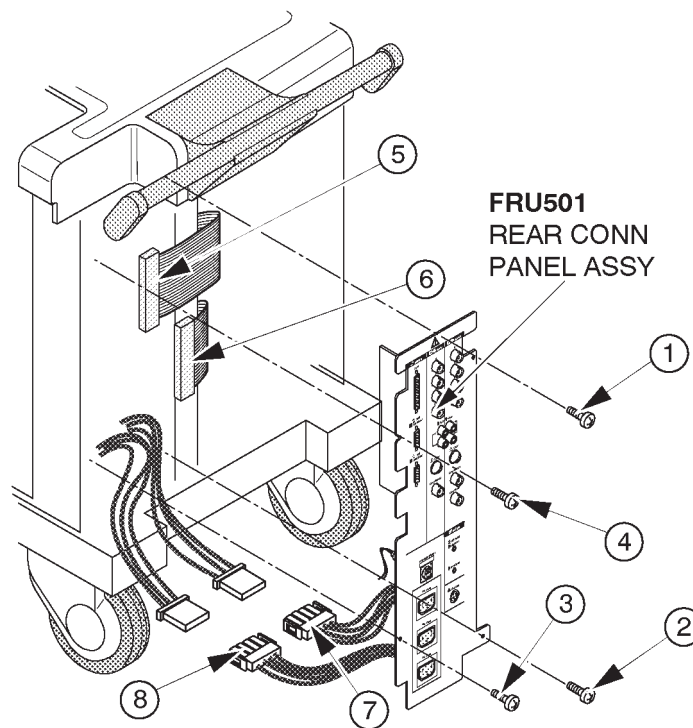

REAR CONN PANEL ASSY DISASSEMBLY
ILLUSTRATION 6-85

6-2-62 CNTIF Assy and CNTIF2 Assy (FRU No. 502)

Time Required

30 Minutes

Tool Required

Screwdriver
Hexagonal box wrench

Procedure

- Refer to ILLUSTRATION 6-86.
- 1. Turn OFF the system.
- 2. Remove the Rear CONN Panel Assy (FRU 501). Refer to 6-2-61 on page 6-166.
- 3. Unscrew six hexagonal studs (① – ⑥) using box wrench.
- 4. Remove the CNTIF Assy or the CNTIF2 Assy.

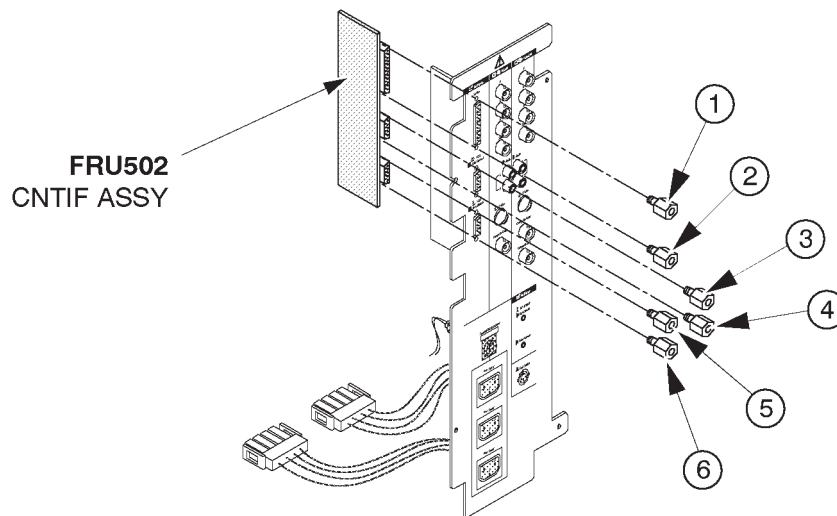

CNTIF(2) ASSY DISASSEMBLY
ILLUSTRATION 6-86

Note

The CNTIF2 Assy includes the Ethernet port for the optional DICOM network connection.

■ 6-2-63 AVIF Assy or BVIF Assy (FRU No. 503)

Time Required

30 Minutes

Tool Required

Screwdriver

Procedure

■ Refer to ILLUSTRATION 6-87.

1. Turn OFF the system.
- 2. Remove the Rear CONN Panel Assy (FRU 501). Refer to 6-2-61 on page 6-166.
3. Disconnect three connectors (① – ③).

Note

In case of the BVIF Assy, disconnect two connectors (① and ③).

4. Unscrew eleven screws (④ – ⑭).
5. Remove the AVIF Assy or BVIF Assy.

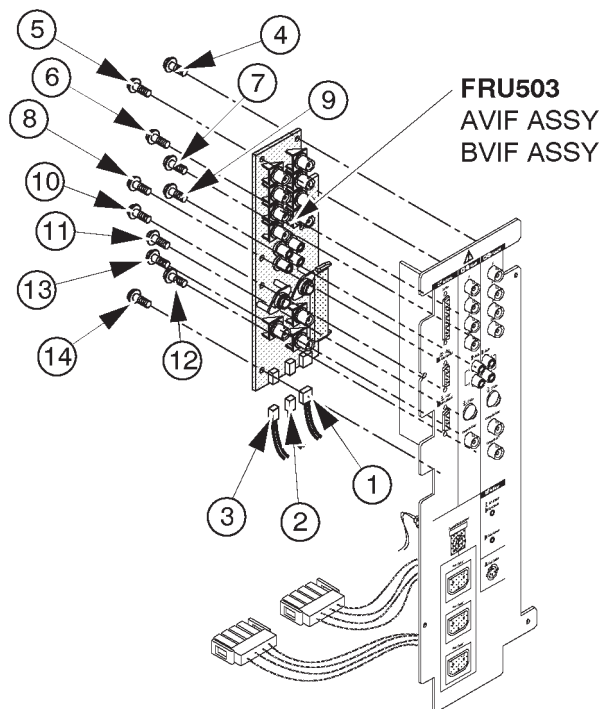

AVIF/BVIF ASSY DISASSEMBLY
ILLUSTRATION 6-87



■ **6-2-64 Circuit Protector (FRU No. 504: 15A, FRU No. 505: 7.5A)**

Time Required

1 Hour

Tool Required

Screwdriver
Soldering Iron

Procedure

■ Refer to ILLUSTRATION 6-88.

1. Turn OFF the system.
- 2. Remove the Rear CONN Panel Assy (FRU 501). Refer to 6-2-61 on page 6-166.
3. Remove the soldered cord (① and ②).
4. Remove the Circuit Protector toward the direction indicated by the arrow.

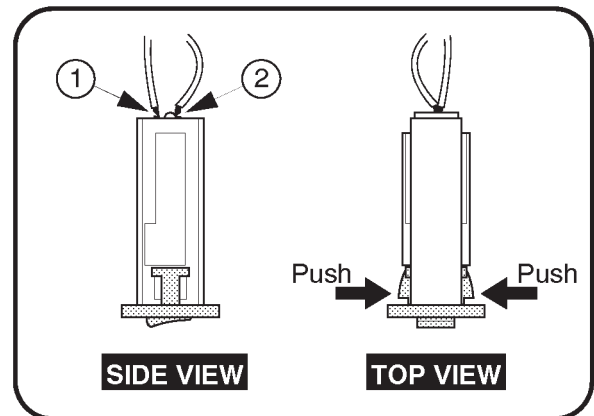
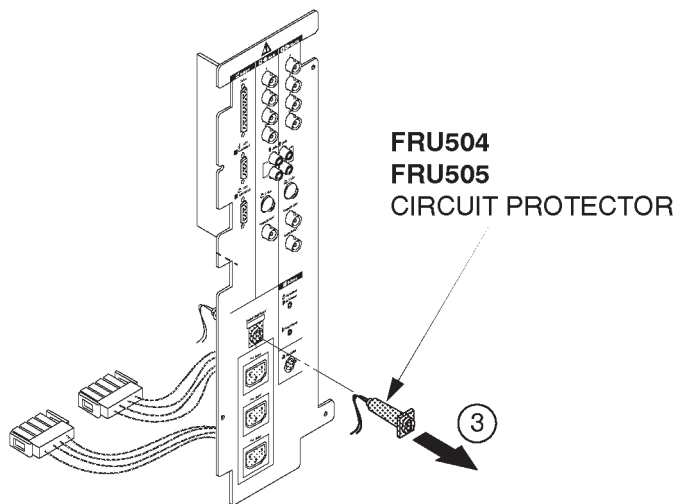

CIRCUIT PROTECTOR DISASSEMBLY
ILLUSTRATION 6-88

6-2-65 ECG Board Assy (FRU No. 506)

Time Required

15 Minutes

Tool Required

Screwdriver

Procedure

Refer to ILLUSTRATION 6-89.

1. Turn OFF the system.
2. Remove the Side Cover Right (FRU 302). Refer to 6-2-32 on page 6-128.
3. Remove the ECG Panel Assy (FRU 511). Refer to 6-2-66 on page 6-172.
4. Disconnect the connector (①).
5. Unscrew two screws (② and ③).
6. Remove the ECG Board Assy.

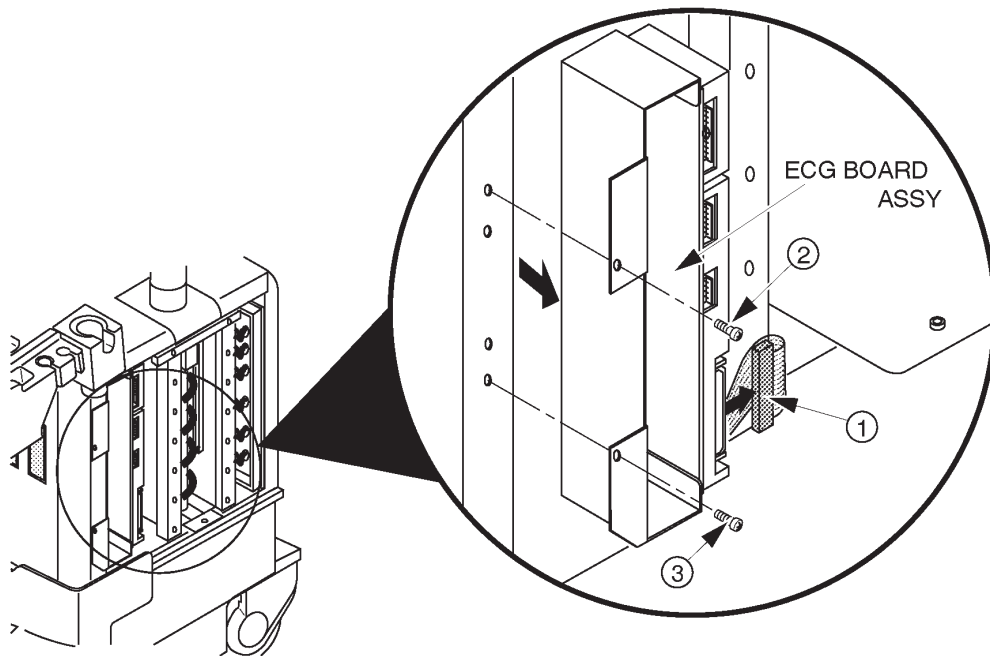

ECG BOARD ASSY DISASSEMBLY
ILLUSTRATION 6-89

Note

New type of ECG Board Assy (2207806) has the reserved connector (P69). This connector is not used for the LOGIQ™ 400 console.

6-2-66 ECG Panel Assy (FRU No. 507)

Time Required

10 Minutes

Tool Required

Screwdriver

Procedure

Refer to ILLUSTRATION 6-90.

NOTE

The new type of ECG Panel Assy is installed from production unit of LOGIQ™400 console with software Version 5.01 y or later. Refer to page 6-173.

1. Turn OFF the system.
2. Remove the Side Cover Right (FRU 302). Refer to 6-2-32 on page 6-128.
3. Disconnect three connectors (① – ③).
4. Unscrew two screws (④ and ⑤).
5. Loosen two screws (⑥ and ⑦).
6. Remove the ECG Panel Assy.

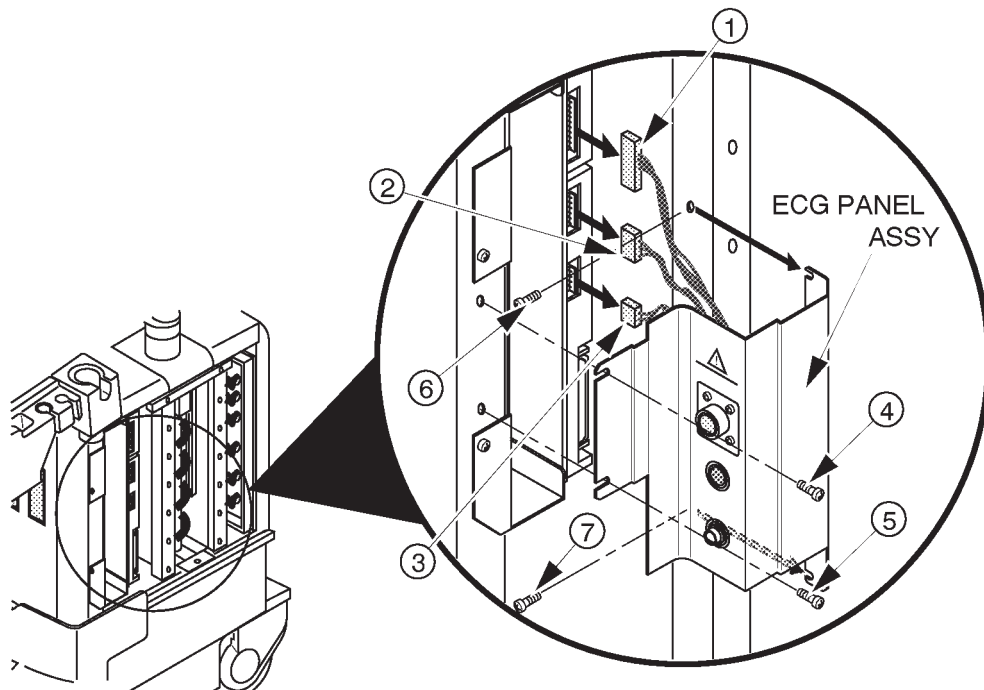

ECG PANEL ASSY DISASSEMBLY (a)

ILLUSTRATION 6-90

6-2-66 ECG Panel Assy (FRU No. 507) (continued)

NOTE

To remove the new type of ECG Panel Assy, unscrew two screws (1) and (2). Loosen two screws (3) and (4). Remove the new type of ECG Panel Assy after disconnect three connectors (5)–(7).

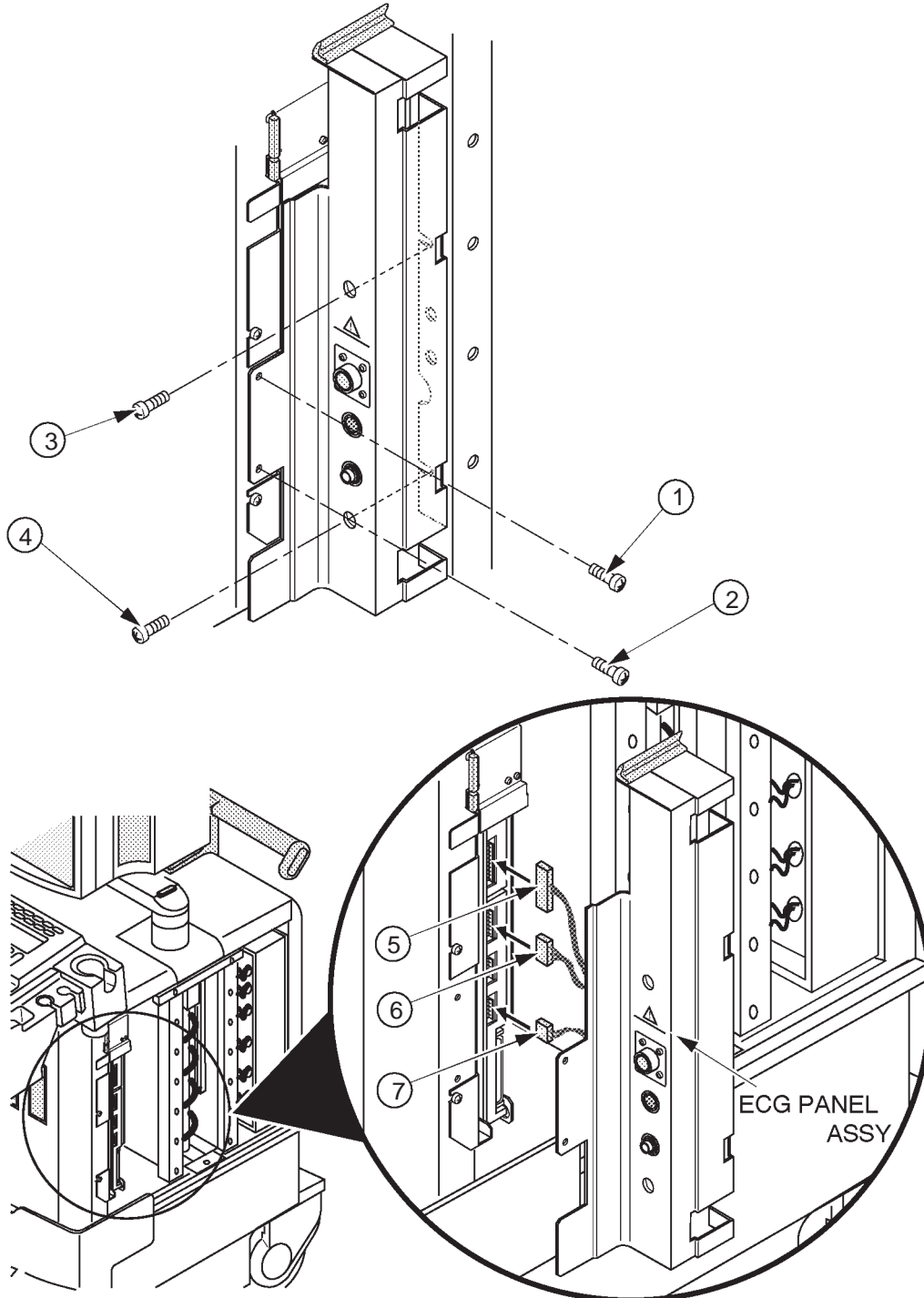

ECG PANEL ASSY DISASSEMBLY (b)

ILLUSTRATION 6-91

6-2-67 Nest Fan Assy (FRU No. 511)

Time Required

20 Minutes

Tool Required

Screwdriver

Procedure

Refer to ILLUSTRATION 6-93.

1. Turn OFF the system.
2. Remove the Side Cover Left (FRU 301). Refer to 6-2-31 on page 6-127.
3. Disconnect two connectors (① and ②).
4. Unscrew two screws (③ and ④).
5. Pull out the Nest Fan Assy leftwards.

NOTE

The FRAME BASE is installed from the production unit of the LOGIQ™400 console with software version 5.01 y or later. Refer to ILLUSTRATION 6-92. Unscrew six screws (① – ⑥) to remove the FRAME BASE.

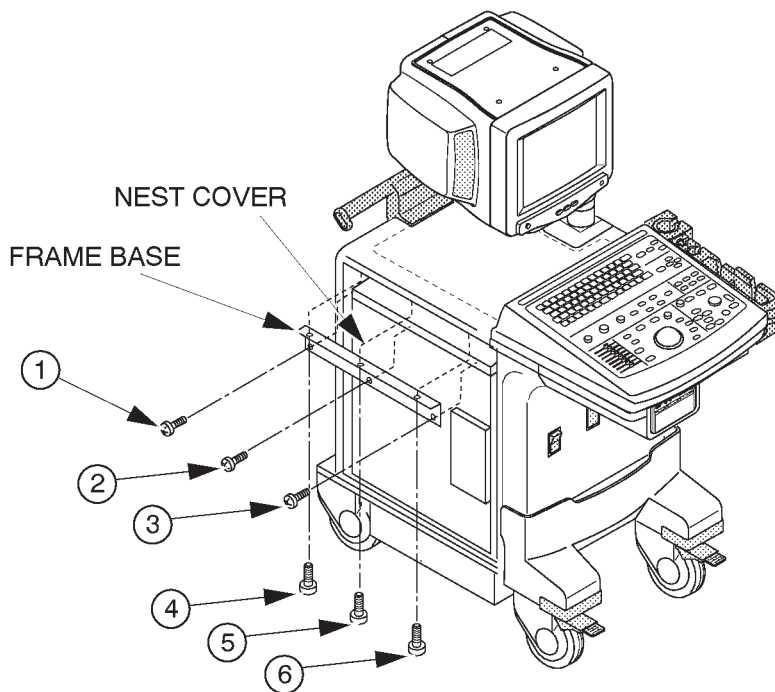

NEST FAN ASSY DISASSEMBLY(a)

ILLUSTRATION 6-92

■ 6-2-67 Nest Fan Assy (FRU No. 511) (continued)

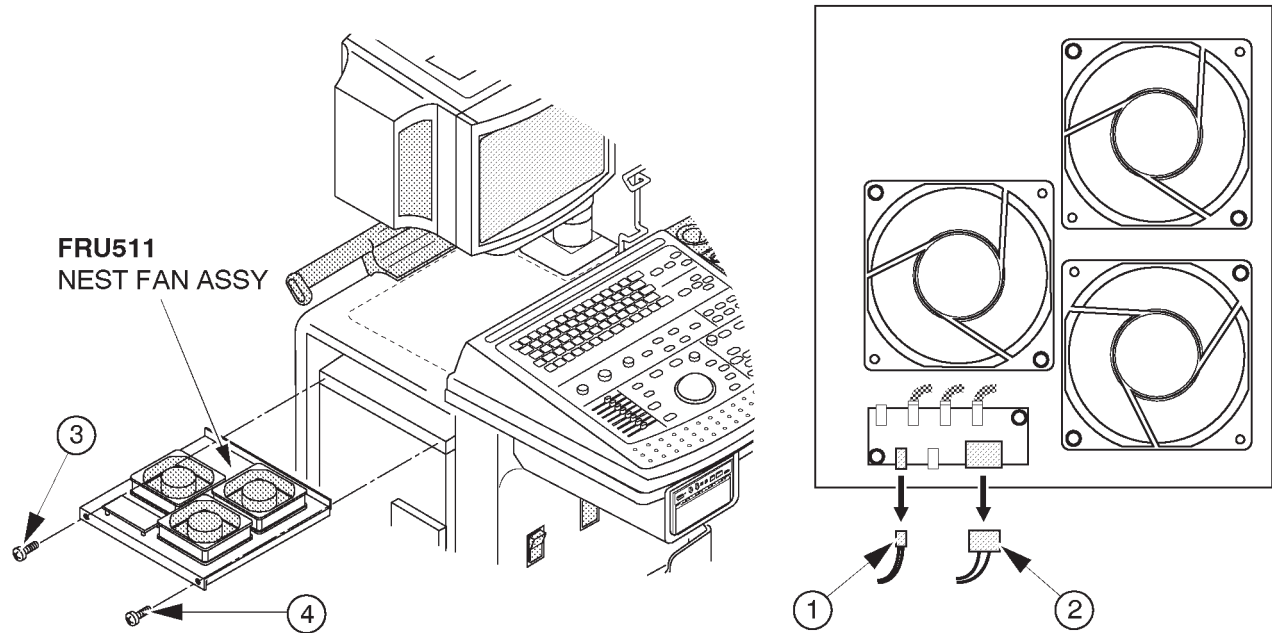

NEST FAN ASSY DISASSEMBLY
ILLUSTRATION 6-93

6–2–68 Probe CONN Set Assy (FRU No. 512 for 3 slots model, FRU No. 513 for 2 slots model)**Time Required**

30 Minutes

Tool Required

Screwdriver

Procedure**Refer to ILLUSTRATION 6–94.**

1. Turn OFF the system.
2. Remove the Front Base Cover (FRU 305). Refer to 6–2–35 on page 6–131.
3. Remove the Front Cover (FRU 306). Refer to 6–2–36 on page 6–132.
4. Remove the Side Cover Right (FRU 302). Refer to 6–2–32 on page 6–128.
5. Remove the Keyboard Bottom Cover (FRU 307). Refer to 6–2–37 on page 6–134.
6. Remove the HDD LED Assy (FRU 526). Refer to 6–2–76 on page 6–196.
7. Remove the Power Switch Assy (FRU 527). Refer to 6–2–77 on page 6–197.
8. Disconnect one connector (①).
9. Disconnect four connectors (② – ⑤).
10. Loosen two screws (⑥ and ⑦).
11. Unscrew two screws (⑧ and ⑨).
12. Slightly lift the Probe CONN Set Assy up, move it leftwards, and remove it.
13. Unscrew two screws (⑩ and ⑪).
14. Remove the Blind Metal Plate.

6-2-68 Probe CONN Set Assy (FRU No. 512 for 3 slots model, FRU No. 513 for 2 slots model) (continued)

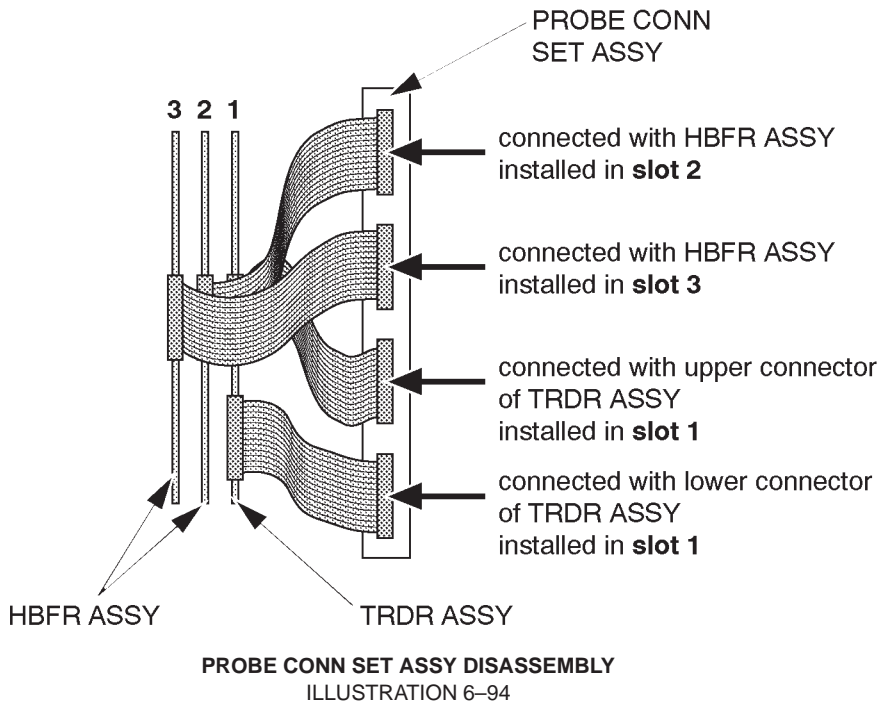
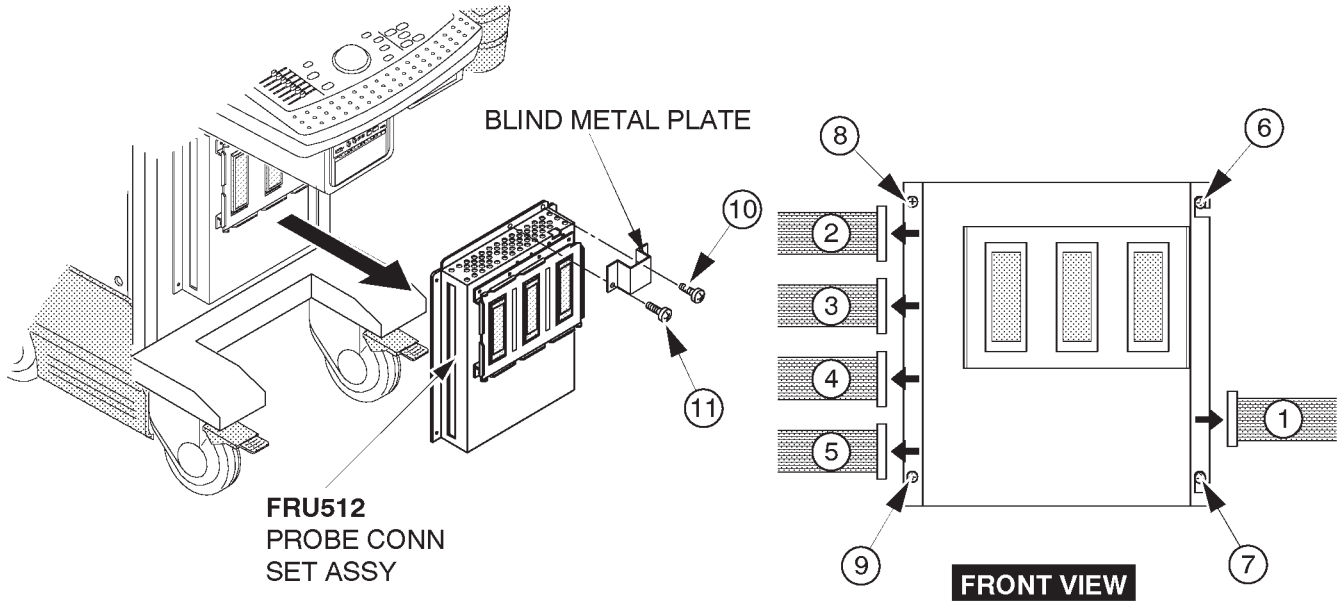

■ **6-2-69 Connector Cover (FRU No. 514)**

Time Required

10 Minutes

Tool Required

Screwdriver

Procedure

■ Refer to ILLUSTRATION 6-95.

1. Turn OFF the system.
2. Unscrew four screws (① – ④).
3. Remove the Connector Cover.

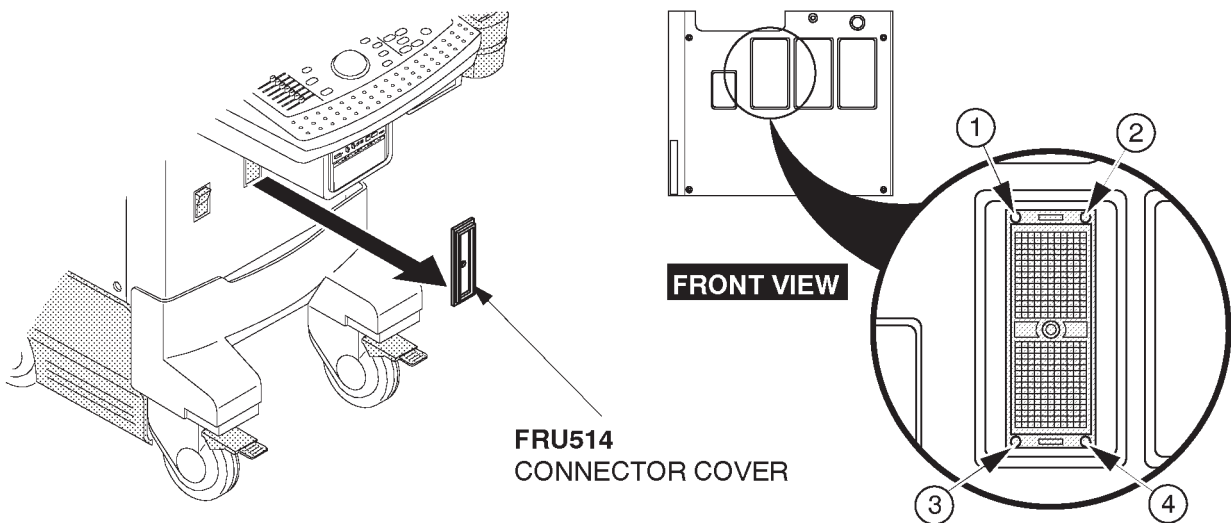

CONNECTOR COVER DISASSEMBLY
ILLUSTRATION 6-95

■ 6-2-70 Shield Finger Long (FRU No. 515), Shield Finger Short (FRU No. 516)

Time Required

45 Minutes

Tool Required

Screwdriver

Procedure

- Refer to ILLUSTRATION 6-96.
- 1. Turn OFF the system.
- 2. Remove the Front Cover (FRU 306). Refer to 6-2-36 on page 6-132.
- 3. Unscrew eight screws (① – ⑧).
- 4. Remove the connector frame.
- 5. Remove the Shield Finger Long (FRU 515) or Shield Finger Short (FRU 516).

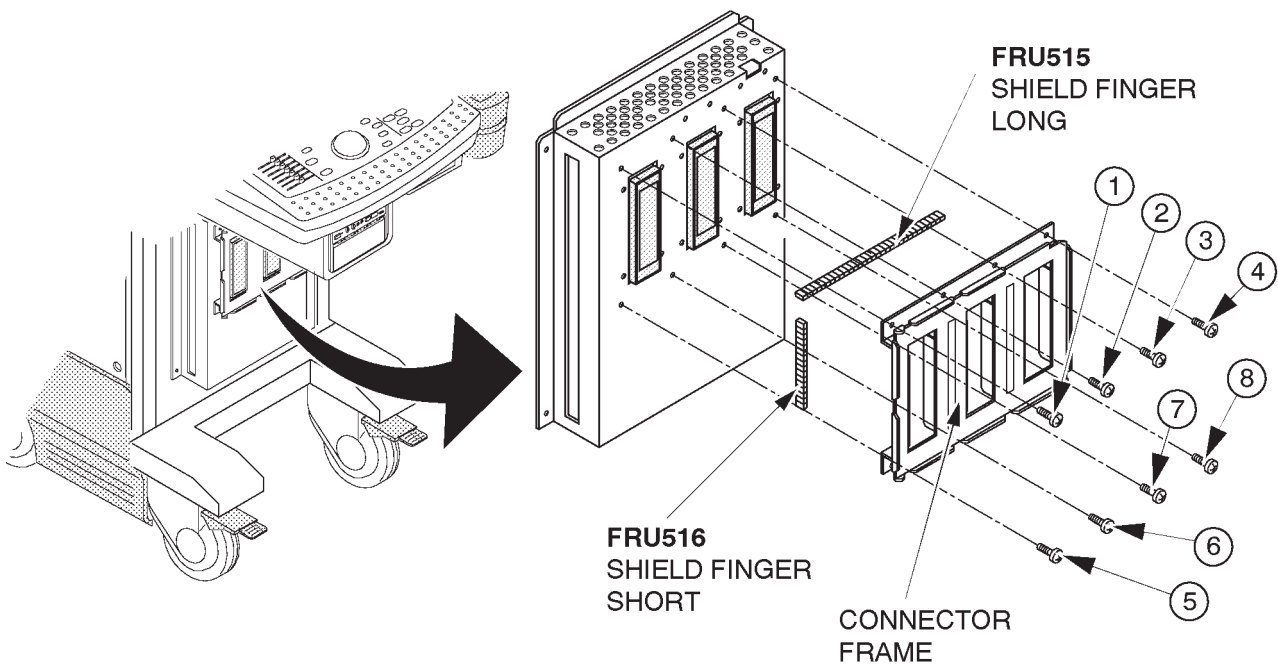

SHIELD FINGER LONG/SHORT DISASSEMBLY
ILLUSTRATION 6-96

6-2-71 Probe CONN 1 Assy (FRU No. 517) or DCON Assy (FRU No. 518)**Time Required**

30 Minutes

Tool Required

Screwdriver

Procedure

Refer to ILLUSTRATION 6-97 on page 6-181.

1. Turn OFF the system.
2. Remove the Probe CONN Set Assy (FRU 512/513). Refer to 6-2-68 on page 6-176.
3. Remove the PRAG Assy (FRU 519). Refer to 6-2-72 on page 6-182.
4. Unscrew eight screws (① – ⑧).
5. Remove the connector frame.
6. Unscrew twelve screws (⑨ – ⑳).
7. Unscrew three screws (㉑ – ㉓).
8. Unscrew two studs (㉔ and ㉕).
9. Remove the Probe CONN 1 Assy or DCON Assy.

6-2-71 Probe CONN 1 Assy (FRU No. 517) or DCON Assy (FRU No. 518) (continued)

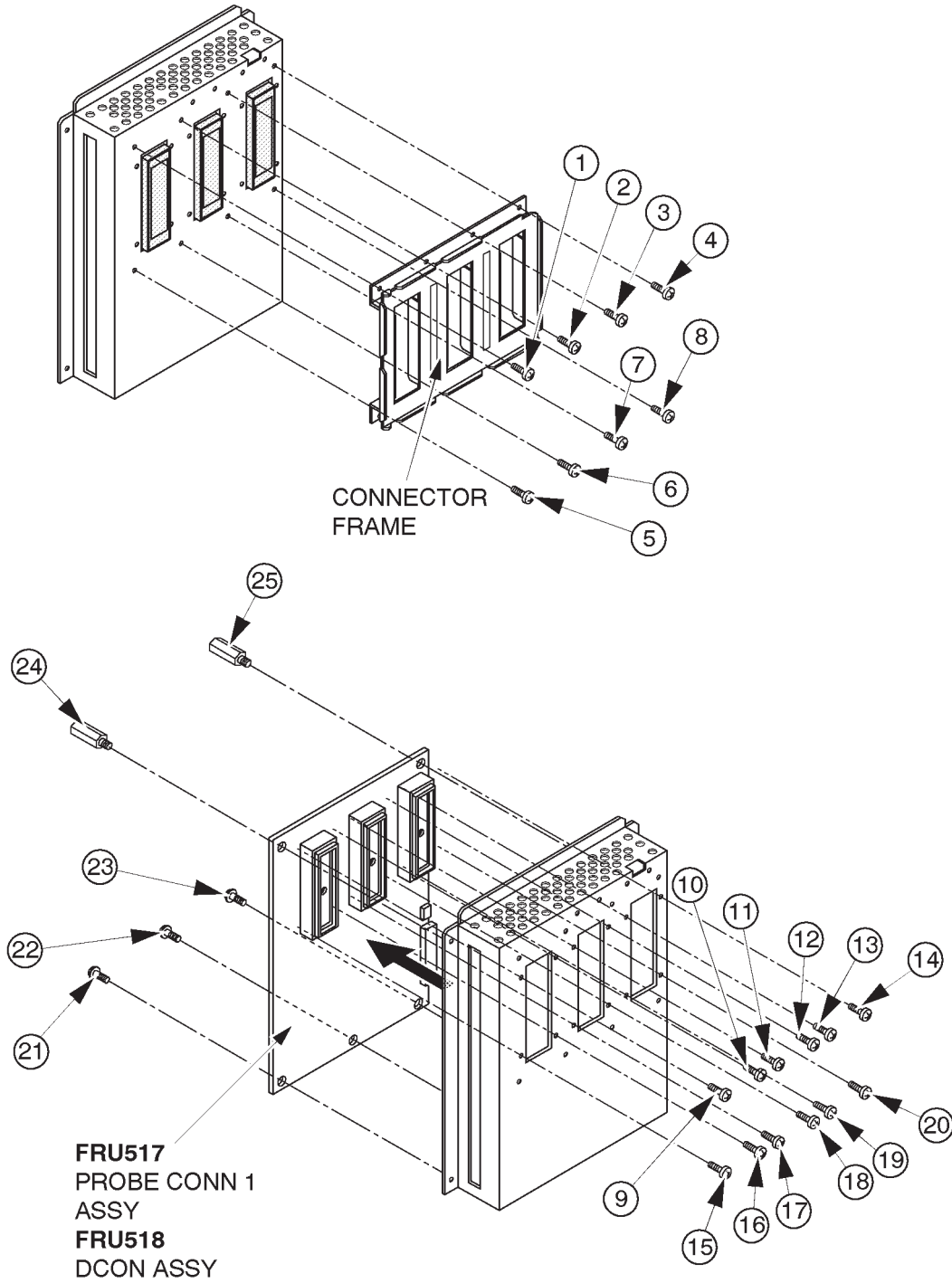

PROBE CONN 1/DCON ASSY DISASSEMBLY
ILLUSTRATION 6-97

■ **6-2-72 PRAG Assy (FRU No. 519)**

Time Required

45 Minutes

Tool Required

Screwdriver

Procedure

■ Refer to ILLUSTRATION 6-98.

1. Turn OFF the system.
- 2. Remove the Probe CONN Set Assy (FRU 512/513). Refer to 6-2-68 on page 6-176.
3. Unscrew seven screws (① – ⑦).
4. Unscrew three screws (⑧ – ⑩) to remove the metal bracket.
5. Disconnect two connectors (⑪ and ⑫).
6. Remove the PRAG Assy.

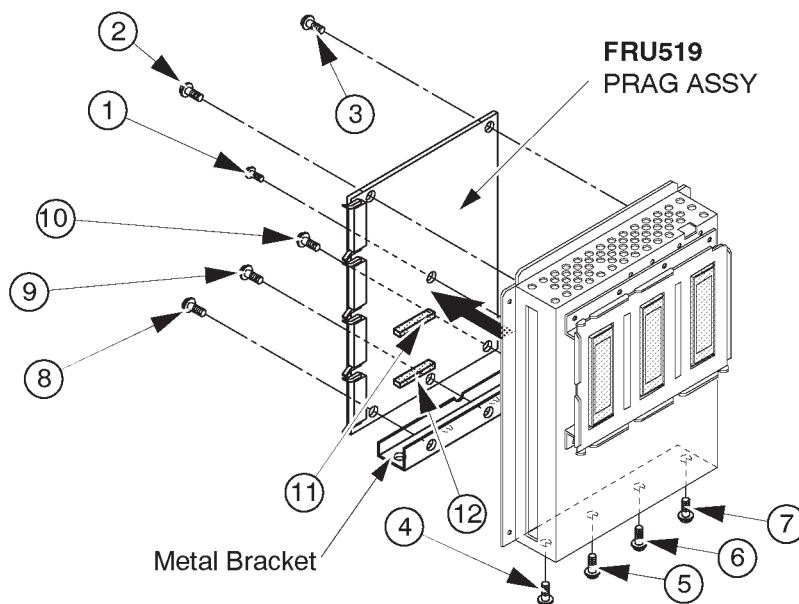

PRAG ASSY DISASSEMBLY

ILLUSTRATION 6-98

This page is left blank intentionally.

6-2-73 MODD (FRU No. 520), MODD Fan (FRU No. 521), MODD Holder Assy (FRU No. 522)**Time Required**

30 Minutes

Tool Required

Screwdriver

Procedure

- Refer to ILLUSTRATION 6-99 on page 6-185.
 1. Turn OFF the system.
 - 2. Remove the Keyboard Panel Assy (FRU 400). Refer to 6-2-49 on page 6-147.
 3. Disconnect the MODD Fan Power Cable.
 4. Unscrew two screws (① and ②).
 5. Remove the MODD Fan Assy
 - 6. Remove the HDDB Assy (FRU 525). Refer to 6-2-75 on page 6-195.
 7. Unscrew four screws (③ – ⑥).
 8. Remove the upper metal plate.
 9. Disconnect the SCSI Cable and MODD Power Cable.
 10. Remove the MODD Holder Assy.
 11. Unscrew four screws (⑦ – ⑩).
 12. Remove the MODD.

Note

- There are two types of MODD for the spare parts. The folding method of CB24A (or CB24N) cable is different between the case of using the old MODD (U0052ZA) and the case of using the new one (2187012). For more details regarding the folding cable, refer to 6-6-4 on page 6-263.

6-2-73 MODD (FRU No. 520), MODD Fan (FRU No. 521), MODD Holder Assy (FRU No. 522) (continued)

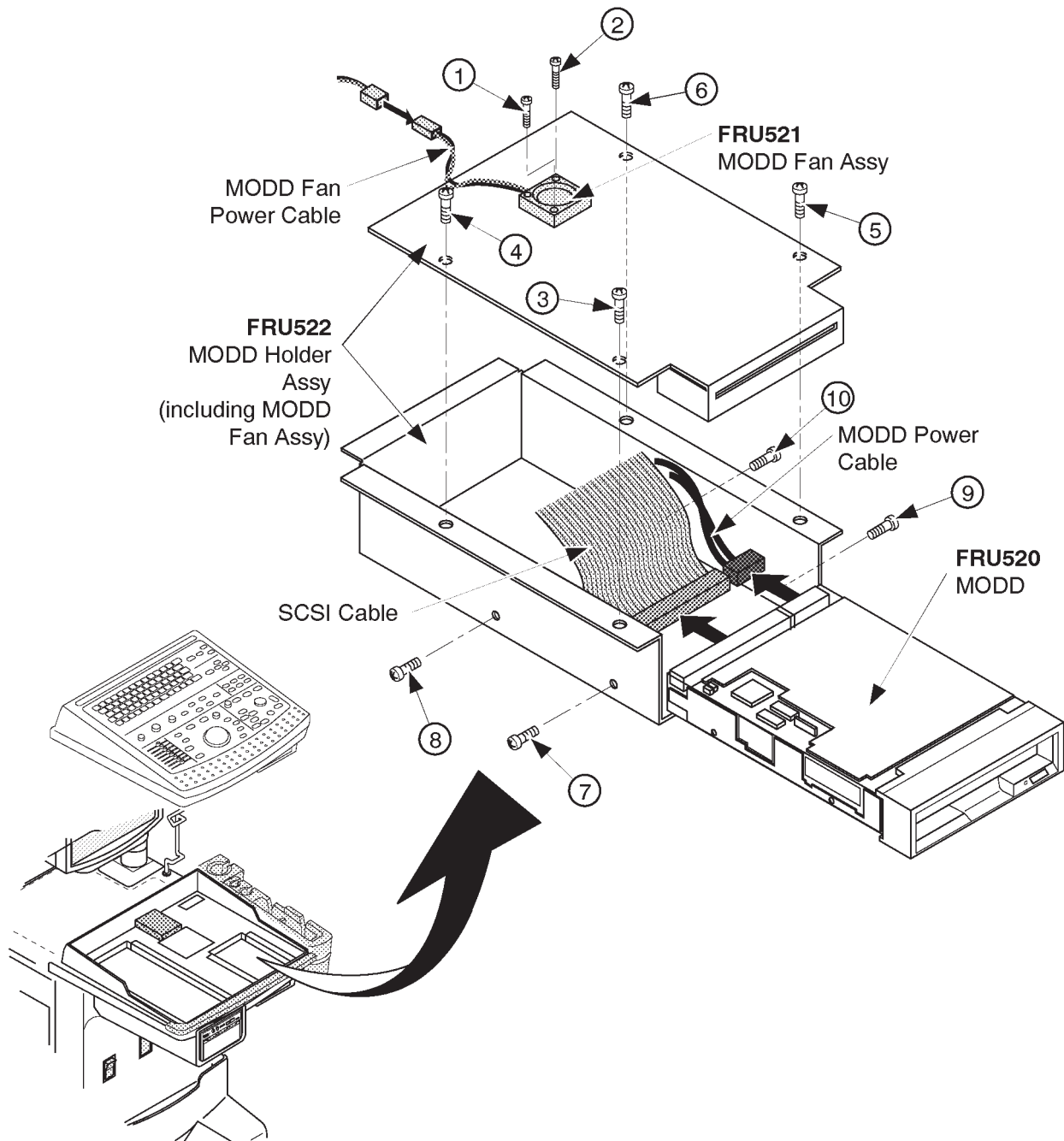

MODD, MODD FAN ASSY, AND MODD HOLDER ASSY REMOVAL
ILLUSTRATION 6-99

6-2-73 MODD (FRU No. 520), MODD Fan (FRU No. 521), MODD Holder Assy (FRU No. 522) (continued)

Note

Make sure that the DIP switches and jumper switches located on the MODD are set as follows before you install a new MODD onto the system.

ILLUSTRATION 6-100 shows the settings of jumper switches when the 3.5-inch HDD is installed on the console.

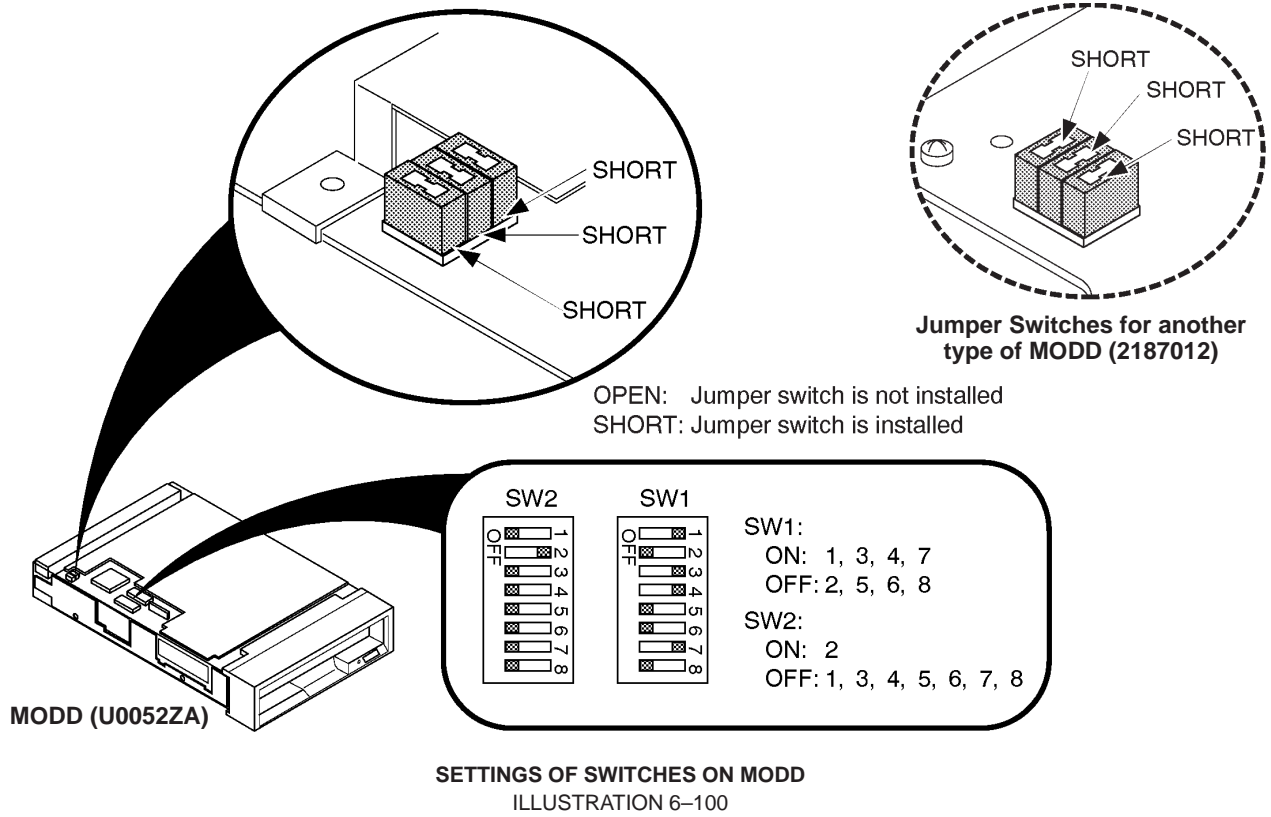

Note

If the 2.5-inch HDD is installed on the console, set the jumper switches as shown in ILLUSTRATION 6-101.

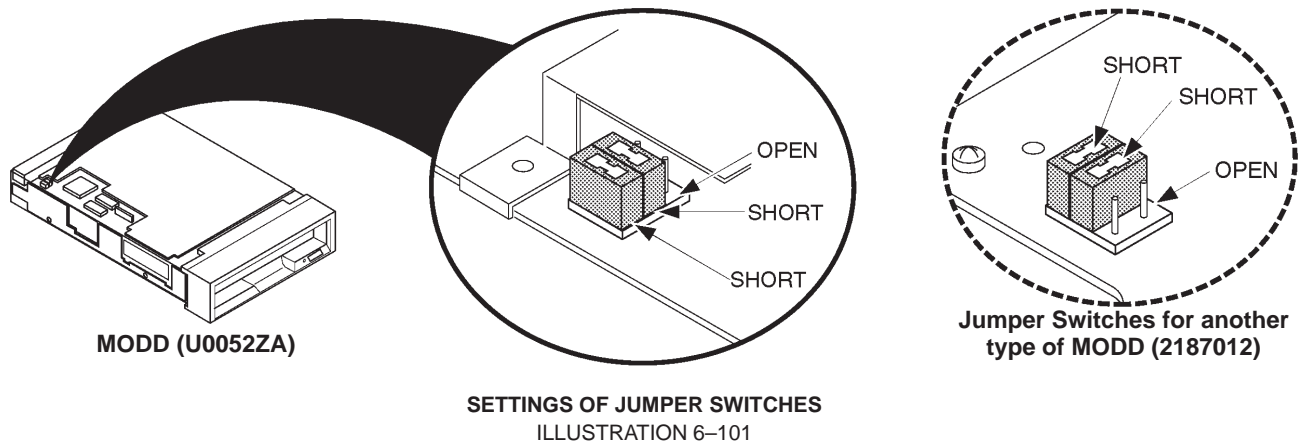

6-2-73 MODD (FRU No. 520), MODD Fan (FRU No. 521), MODD Holder Assy (FRU No. 522) (continued)

Note

When installing the MODD (2187012-2) to the console with the 3.5-inch HDD, make sure that the settings of the DIP switches and the jumper switches are as shown in ILLUSTRATION 6-102.

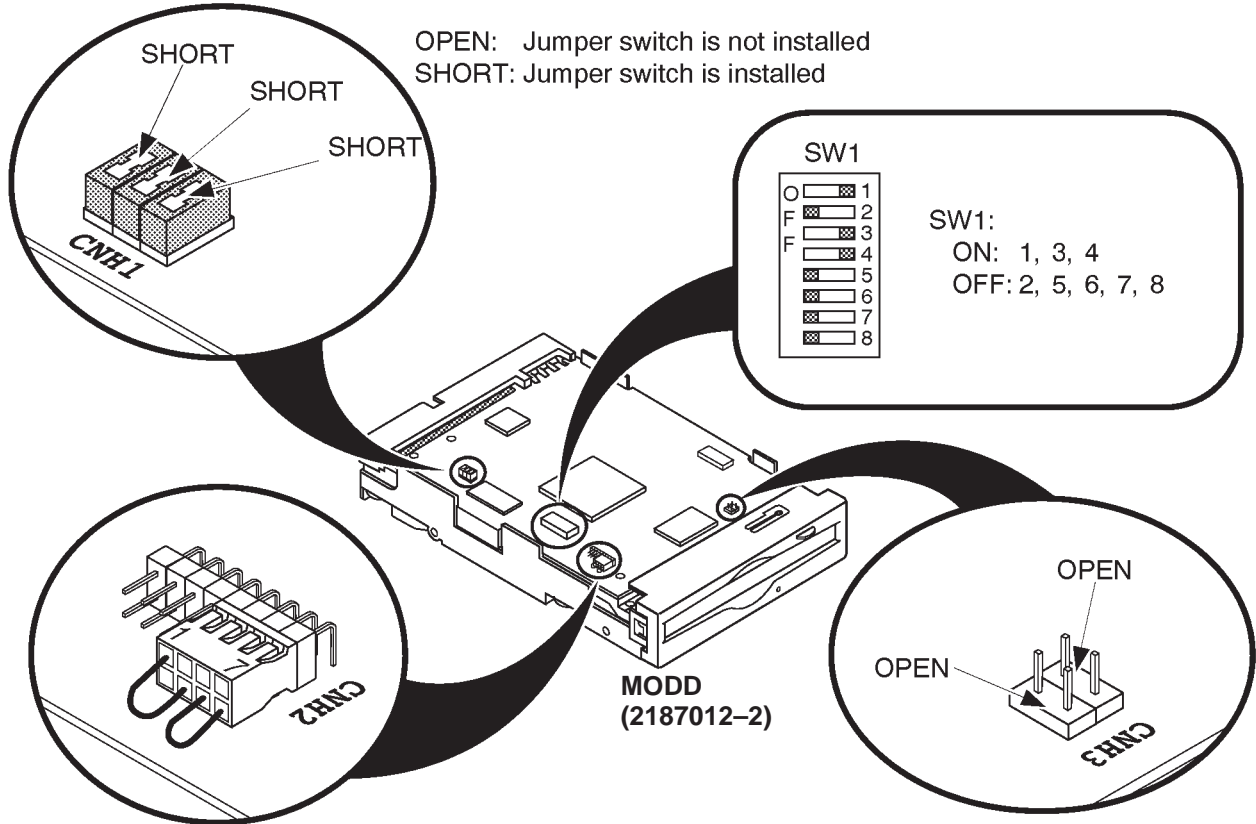

SETTINGS OF SWITCHES ON MODD
ILLUSTRATION 6-102

Note

When installing the MODD (2187012-2) to the console with the 2.5-inch HDD, set the jumper switches as shown in ILLUSTRATION 6-103.

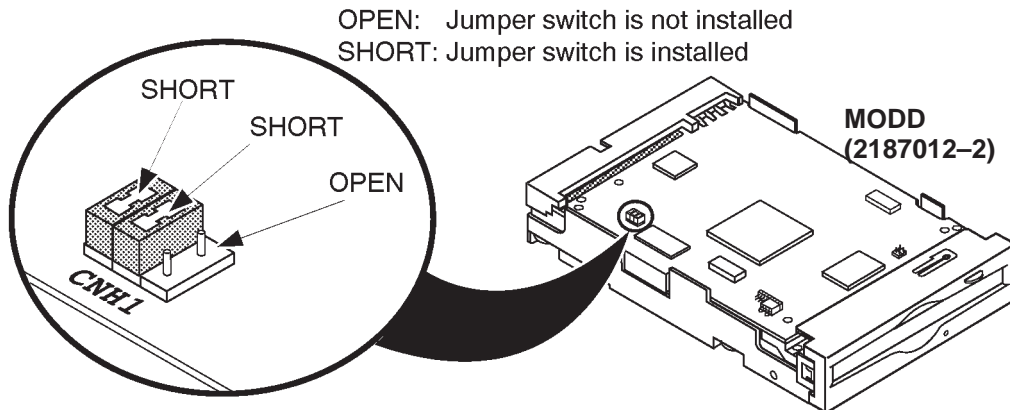

SETTINGS OF SWITCHES ON MODD
ILLUSTRATION 6-103

6-2-73 MODD (FRU No. 520), MODD Fan (FRU No. 521), MODD Holder Assy (FRU No. 522) (continued)**Emergency Ejection**

When your disk is not mounted and the eject button does not function, eject the disk following the procedure below:



Use the emergency ejection procedure only in emergency situations. If this procedure is used while a MO disk is inserted, data in the disk can be destroyed.

1. Turn the system power OFF.
2. Unfold and straighten one end of a large wire paper clip.
3. Insert the straightened end of the clip into the emergency eject hole and press firmly.

This will eject the disk.

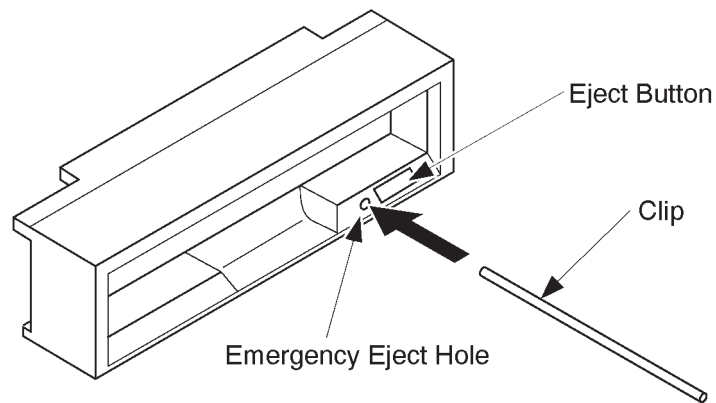

EMERGENCY EJECTION
ILLUSTRATION 6-104

6–2–74 HDD Assy (FRU No. 523), HDD Holder Assy (FRU No. 524)**Time Required**

15 Minutes

Tool Required

Screwdriver

Procedure

Refer to ILLUSTRATION 6–105.

1. Make sure the customer data is saved on a MO disk. Refer to 4–3–3 (D), USER DATA BACK UP on page 4–22.
2. Turn OFF the system.
3. Remove the Keyboard Panel Assy (FRU 400). Refer to 6–2–49 on page 6–147.
4. Remove the HDDB Assy (FRU 522). Refer to 6–2–75 on page 6–195.
5. Unscrew two screws (① and ②).
6. Remove the HDD Holder Assy.
7. Unscrew four screws (③ – ⑥).
8. Remove the HDD (FRU 523) out of the HDD Holder Assy (FRU 524).

Note

After replacing a HDD Assy with new one, the following works have to be done:

- a. Set up the system preset parameters without regard to current settings. For set-up procedures, refer to LOGIQ™ 400 Proprietary Manual, 2127662.
 - a–1. Set the Country/Zone properly. It takes approximately 40 minutes to complete this step.
 - a–2. Set other three parameters, Video Signal, Power Frequency and Modem Kind.
 - a–3. Reset the system using System Reset function of the Service Menu. Refer to LOGIQ™ 400 Proprietary Manual, 2127662.
- b. Install the customer data into new HDD using the back-up disk(s) after resetting the system. Refer to 4–3–3 (D), USER DATA BACK UP on page 4–22.
- c. Set the User Option properly. To set the User Option properly, it is necessary to record the status of the options using the User Option Display before replacing the HDD. For the User Options Set-Up, refer to LOGIQ™ 400 Proprietary Manual, 2127662.

6-2-74 HDD Assy (FRU No. 523), HDD Holder Assy (FRU No. 524) (continued)**Note**

In the case of the B/W monitor console, it is necessary to change the settings of Option Set and System Parameters after replacing a HDD Assy and setting the Country/Zone. If the required changes are not done properly, the system will not be functioning properly and the system error messages are displayed on the CRT monitor screen frequently because the system is initialized as a CFM console. The required changes are:

(1) The following items in the Option Set Menu shall be set to the "Not Installed".

02	PW Doppler
03	Color Flow Mapping
04	B Color
05	Dop/CFM for Intravaginal Probe
06	Segmented Doppler
07	Real Time Auto Doppler Trace
17	Heading VCR Playback

(2) The following parameters in the System Parameter shall be set to the "White".

Col Sys Inf
Col ImagCrs
Col Scale
Col Comment
Col Mes Crs
Col Applcat
Col Moving
Col Aux
Col DopTrace

For more details regarding the setting procedures, refer to LOGIQ™ 400 Proprietary Manual, 2127662 and User Manual.

■ 6-2-74 HDD Assy (FRU No. 523), HDD Holder Assy (FRU No. 524) (continued)

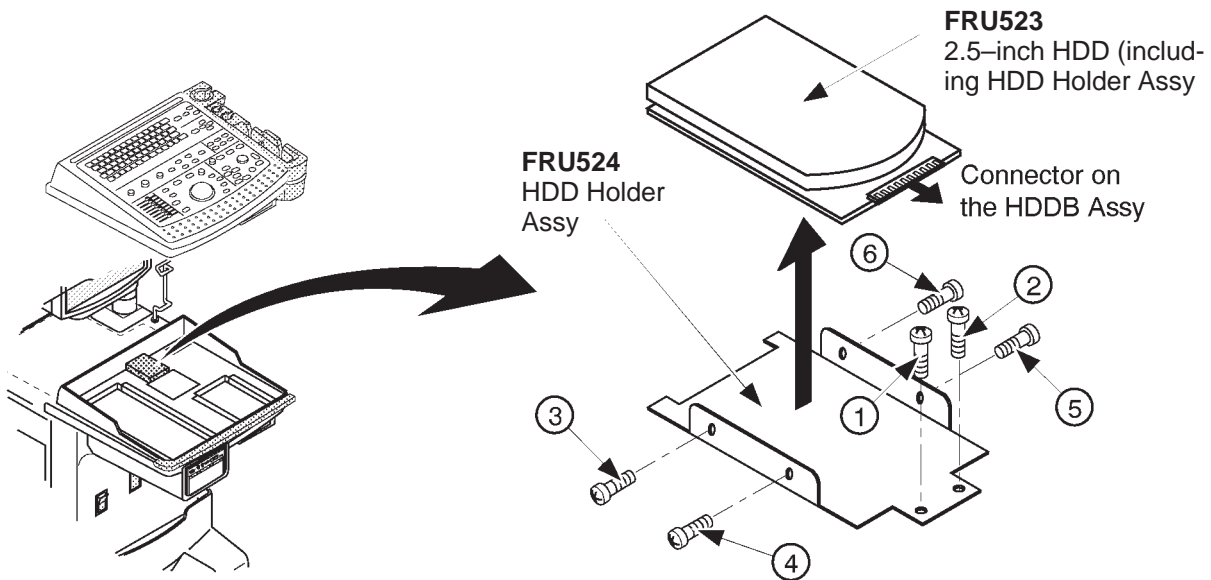

HDD ASSY AND HDD HOLDER ASSY DISASSEMBLY
ILLUSTRATION 6-105

■ 3.5-Inch HDD Disassembly

■ Refer to ILLUSTRATION 6-106.

1. Make sure the customer data is saved on MO disk. Refer to 4-3-3 (D), USER DATA BACK UP on page 4-22.
2. Turn OFF the system.
- 3. Remove the Keyboard Panel Assy (FRU 400). Refer to 6-2-49 on page 6-147.
4. Unscrew two screws (① and ②).
5. Pull out the HDD Holder2 Assy.
- 6. Disconnect three connectors, CB24N, CB5N, and CB45N. Refer to ILLUSTRATION 6-106.
7. Unscrew four screws (③ – ⑥).
8. Remove the HDD (FRU 523) out of the HDD Holder2 Assy (FRU 536).

6-2-74 HDD Assy (FRU No. 523), HDD Holder Assy (FRU No. 524) (continued)

3.5-Inch HDD Disassembly (continued)

Note

After replacing a HDD Assy with new one, the following works have to be done:

- a. Set up the system preset parameters without regard to current settings. For set-up procedures, refer to LOGIQ™ 400 Proprietary Manual, 2127662.
 - a-1. Set the Country/Zone properly. It takes approximately 40 minutes to complete this step.
 - a-2. Set other three parameters, Video Signal, Power Frequency and Modem Kind.
 - a-3. Reset the system using System Reset function of the Service Menu. Refer to LOGIQ™ 400 Proprietary Manual, 2127662.
- b. Install the customer data into new HDD using the back-up disk(s) after resetting the system. Refer to 4-3-3 (D), USER DATA BACK UP on page 4-22.
- c. Set the User Option properly. To set the User Option properly, it is necessary to record the status of the options using the User Option Display before replacing the HDD. For the User Options Set-Up, refer to LOGIQ™ 400 Proprietary Manual, 2127662.

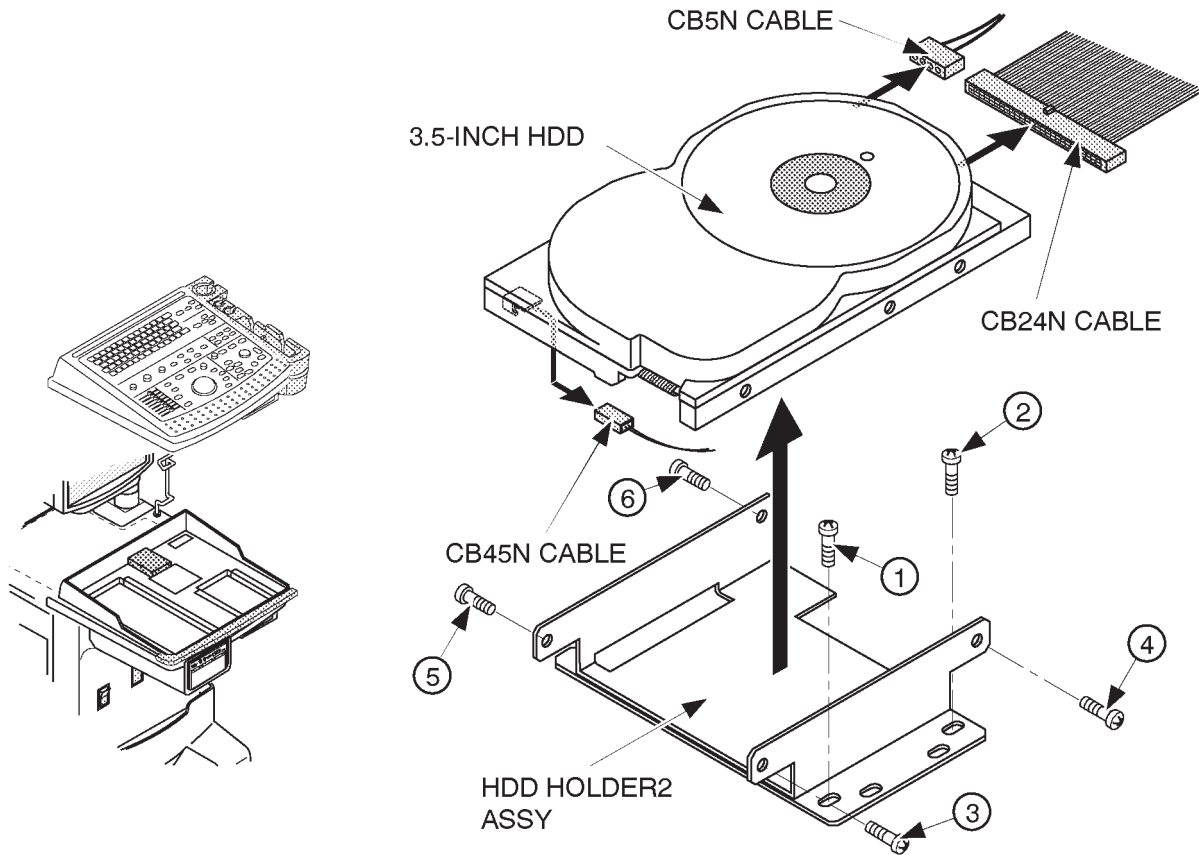

HDD ASSY AND HDD HOLDER2 ASSY DISASSEMBLY
ILLUSTRATION 6-106

6-2-74 HDD Assy (FRU No. 523), HDD Holder Assy (FRU No. 524) (continued)

3.5-Inch HDD Disassembly (continued)

Note

Before installing new 3.5-inch HDD Assy, make sure that the jumper switches located at the bottom of new 3.5-inch HDD are set properly and the terminator module IC is NOT mounted on RP1 as shown in ILLUSTRATION 6-107. If the terminator module IC is installed on the 3.5-inch HDD, remove it out of the IC socket.

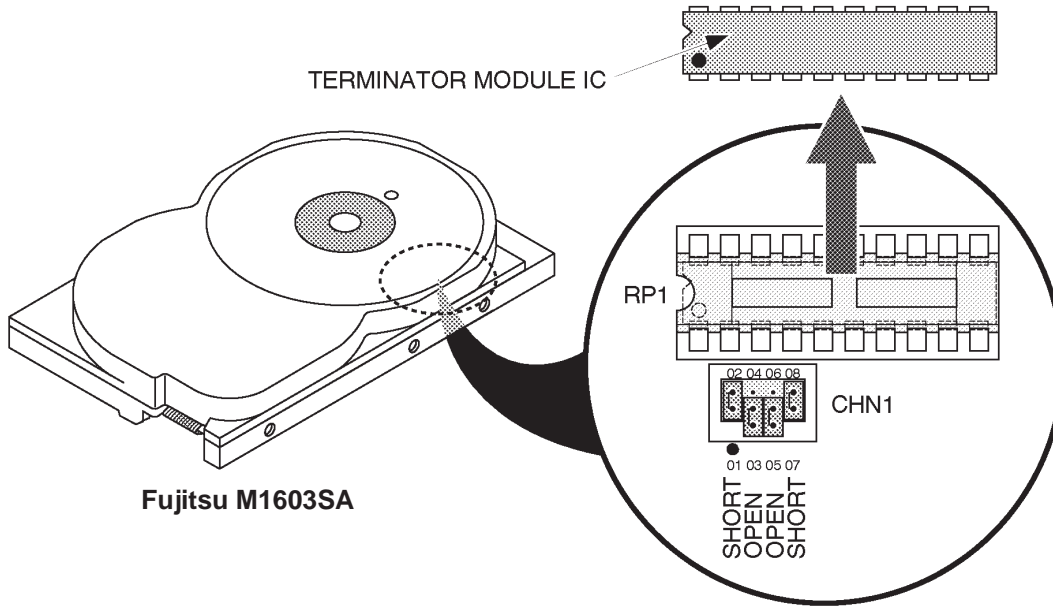

BOTTOM VIEW OF 3.5-INCH HDD
ILLUSTRATION 6-107

Note

The setting of jumper switches for the new 3.5-inch HDD Assy (Quantum™ Fireball™ 1280S) is different from the old one. Refer to ILLUSTRATION 6-108 to check and set the jumper switches properly.

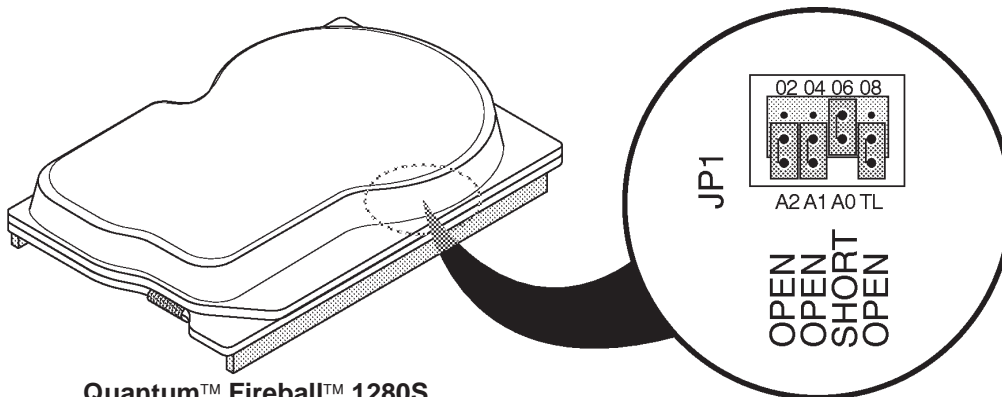

BOTTOM VIEW OF 3.5-INCH HDD (b)
ILLUSTRATION 6-108

6-2-74 HDD Assy (FRU No. 523), HDD Holder Assy (FRU No. 524) (continued)

3.5-Inch HDD Disassembly (continued)

Note

When using the type "Quantum™ Fireball™ EL" of HDD Assy, Refer to ILLUSTRATION 6-109 to check and set the jumper switches on the HDD Assy.

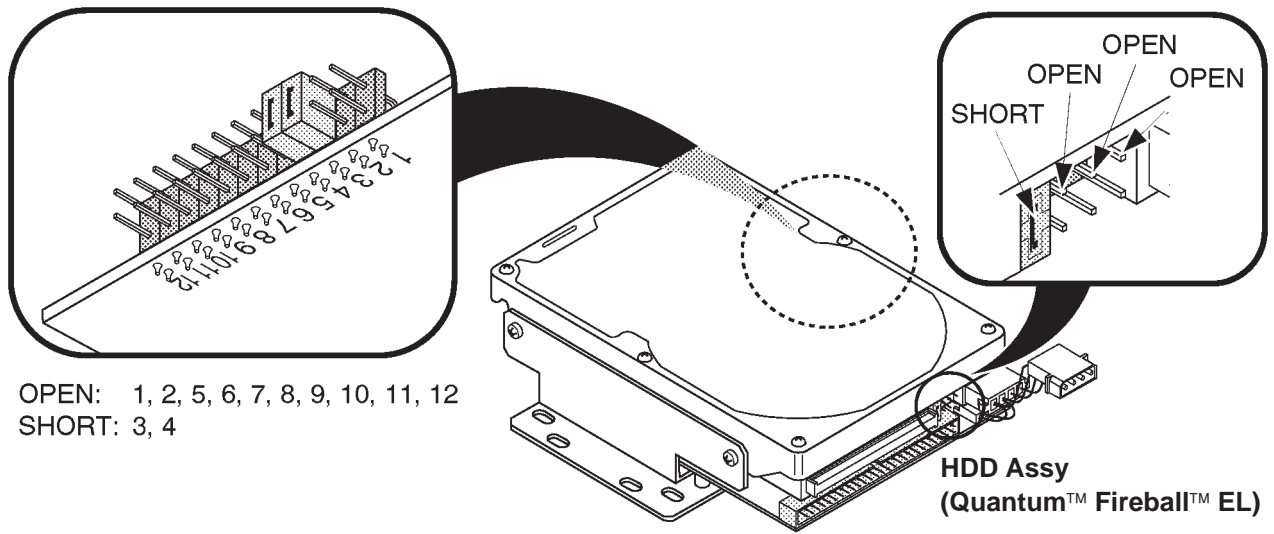

OPEN: 1, 2, 5, 6, 7, 8, 9, 10, 11, 12
SHORT: 3, 4

HDD Assy
(Quantum™ Fireball™ EL)

SETTING OF JUMPER SWITCHES OF HDD ASSY
ILLUSTRATION 6-109

■ 6-2-75 HDDB Assy (FRU No. 525)

Note

The HDDB Assy is not used for the console with the 3.5-inch HDD Assy.

Time Required

15 Minutes

Tool Required

Screwdriver

Procedure

■ Refer to ILLUSTRATION 6-110.

1. Turn OFF the system.
- 2. Remove the Keyboard Panel Assy (FRU 400). Refer to 6-2-49 on page 6-147.
3. Disconnect three connectors (① – ③).
4. Unscrew four screws (④ – ⑦).
5. Remove the HDDB Assy.

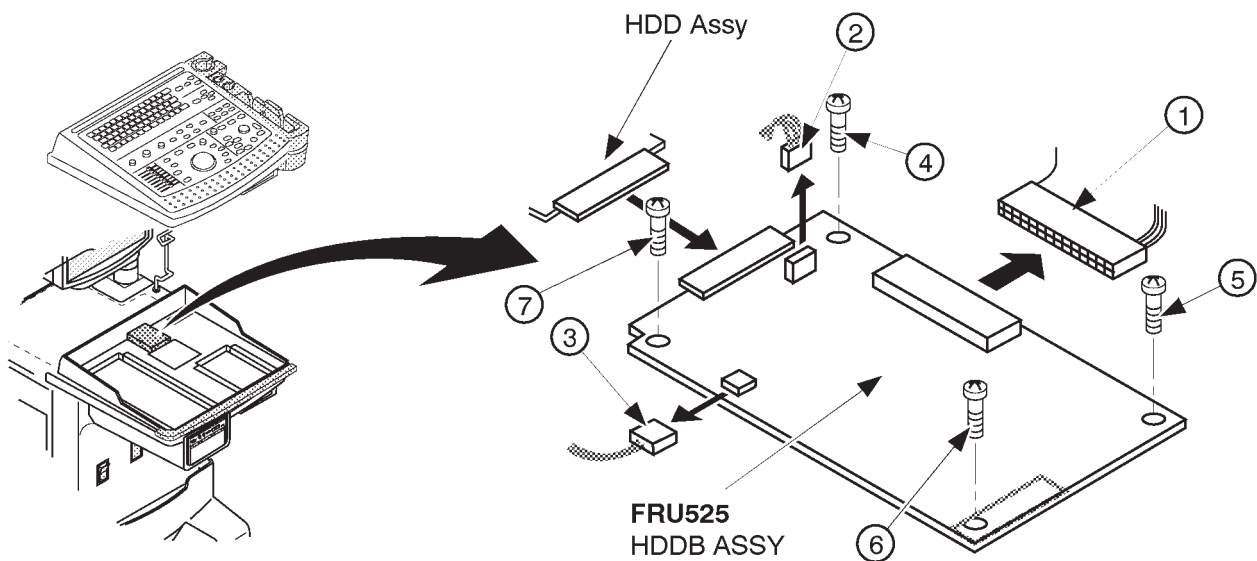

HDDB ASSY DISASSEMBLY
ILLUSTRATION 6-110

6-2-76 HDD LED Assy (FRU No. 526)

Note

The HDD LED Assy is not available on the console with the new type of 3.5-inch HDD Assy (Quantum™ FireBall™ 1280S and Quantum™ FireBall™ EL).

Time Required

15 Minutes

Tool Required

Screwdriver

Procedure

- Refer to ILLUSTRATION 6-111.
- 1. Turn OFF the system.
- 2. Remove the Front Base Cover (FRU 305). Refer to 6-2-35 on page 6-131.
- 3. Remove the Front Cover (FRU 306). Refer to 6-2-36 on page 6-132.
- 4. Unscrew two screws (① and ②).
- 5. Disconnect one connector (③).
- 6. Remove the HDD LED Assy.

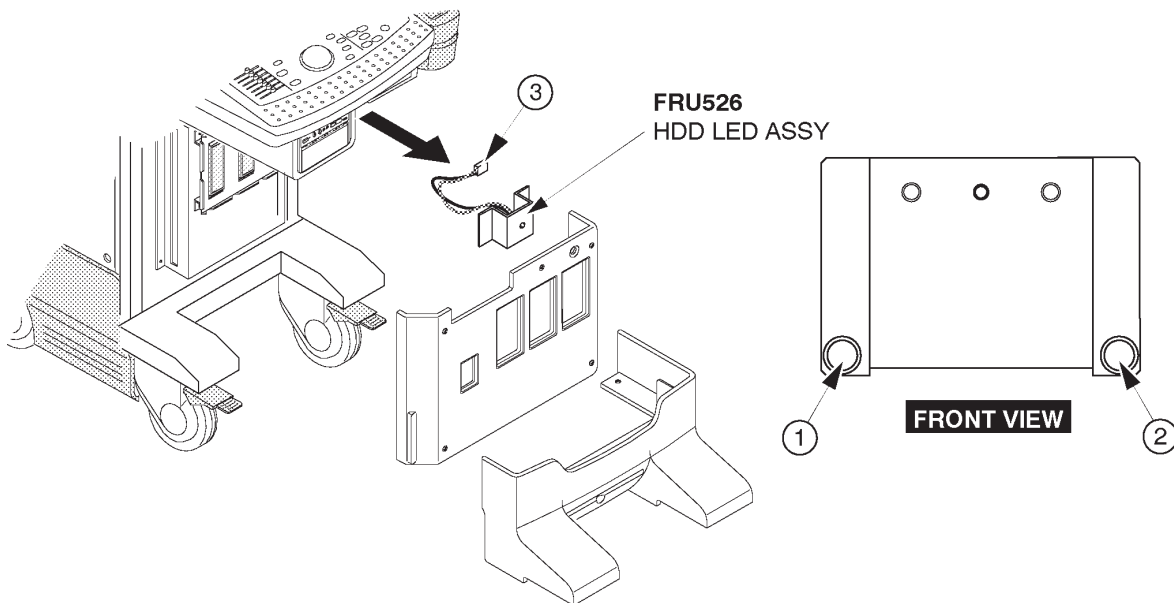

HDD LED ASSY DISASSEMBLY
ILLUSTRATION 6-111

6-2-77 Power Switch Assy (FRU No. 527)**Time Required**

15 Minutes

Tool Required

Screwdriver

Procedure

1. Turn OFF the system.
2. Remove the Front Base Cover (FRU 305). Refer to 6-2-35 on page 6-131.
3. Remove the Front Cover (FRU 306). Refer to 6-2-36 on page 6-132.
4. Unscrew two screws (① and ②).
5. Disconnect one connector (③).
6. Remove the Power Switch Assy.

**POWER SWITCH ASSY DISASSEMBLY**

ILLUSTRATION 6-112

■ 6–2–78 P.C. Board(s) (FRU No. 601 through 612)**Time Required**

15 Minutes

Tool Required

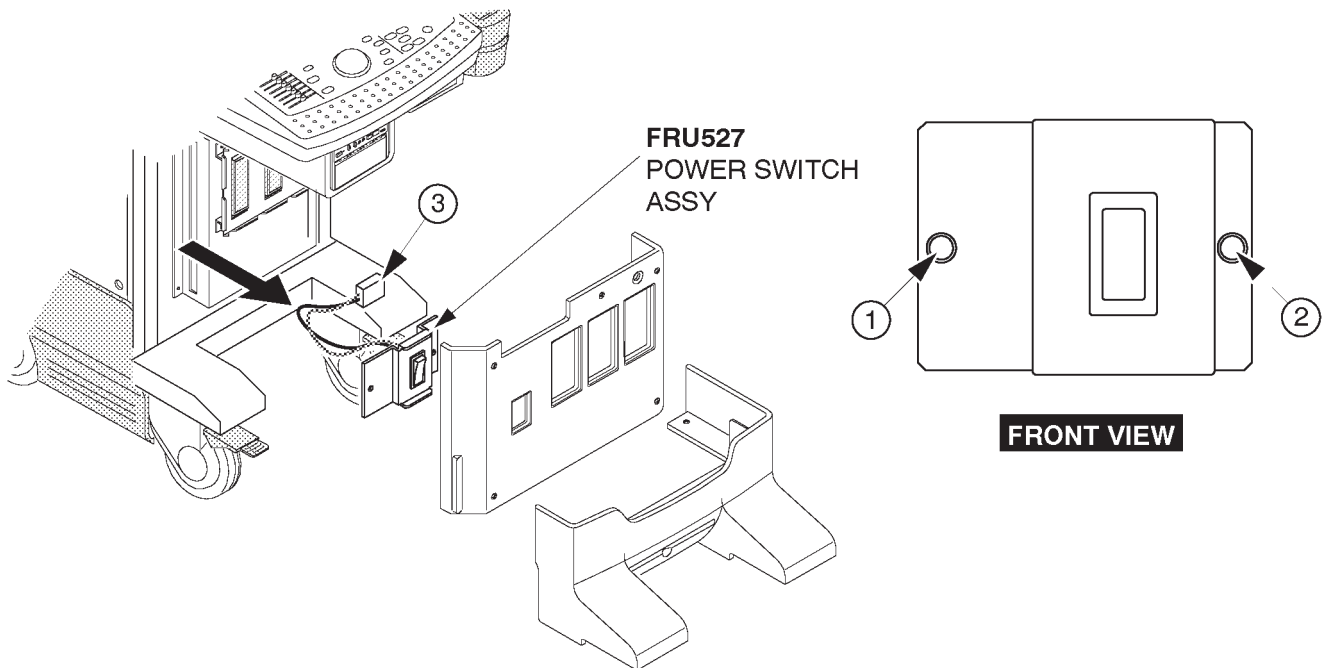
Screwdriver

Procedure

An electrostatic discharge may damage a component. Turn OFF power and wear the wrist strap before you remove circuit boards. Do not unplug the power cord to keep ground continuity.

Do not bend or flex the boards when mounting/dismounting each board. Surface mount IC boards are very susceptible to damage from flex/torque.

■ Refer to ILLUSTRATION 6–113.

1. Turn OFF the system.
- 2. Remove the Side Cover Left (FRU 301). Refer to 6–2–31 on page 6–127.
3. Unscrew the five Nest Cover screws.
4. Remove the Nest Cover.
5. Disconnect two connectors if removing the TRDR Assy. Otherwise, skip this step.
6. Disconnect one connector if removing one of two HBFR Assemblies. Otherwise, skip this step.
7. Move the upper and lower stopper in the direction indicated by the arrow ①.
8. Pull out the board, do not bend it (②).

Note

After replacing a CPU Assy with new one, it is necessary to install the system ID number into the time keeper RAM on new CPU Assy and set up two items among four system parameters, Video Signal and Power Frequency.

For system ID installation procedures, refer to Section 4–3–3 (J), SYSTEM ID ENTRY/DISPLAY in chapter 4 of this manual.

For set-up procedures of system preset parameter, refer to LOGIQ™ 400 Proprietary Manual, 2127662.

6-2-78 P.C. Board(s) (FRU No. 601 through 612) (continued)

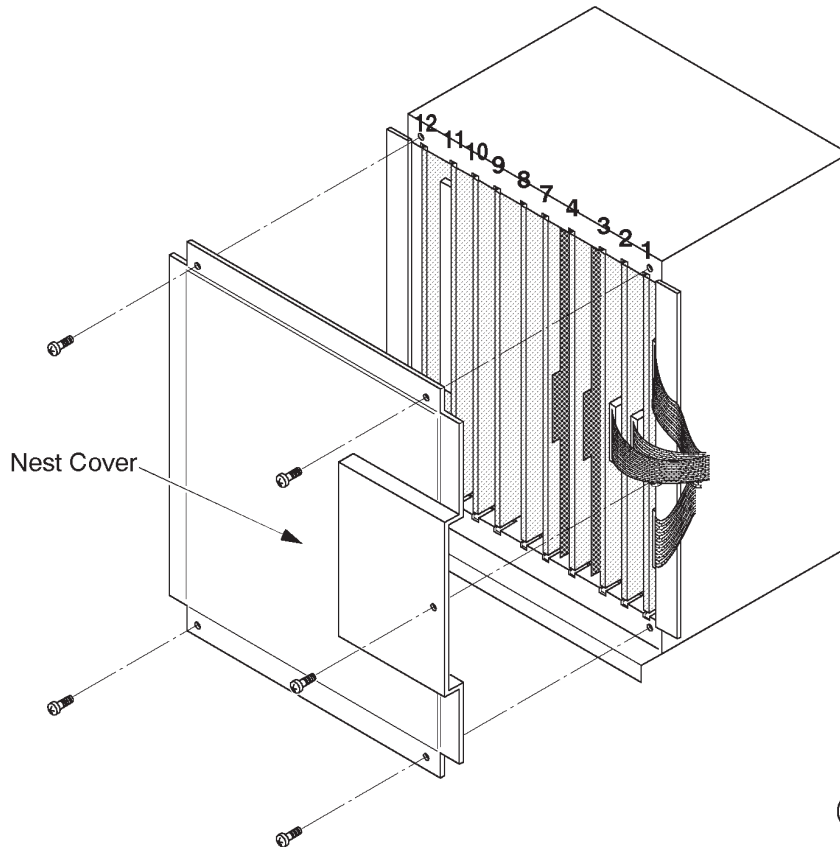

Cardcage Number	Board	NOTE
1	TRDR ASSY	
2	HBFR ASSY	
3	HBFR ASSY	
4	ASPR ASSY	
7	BMRC ASSY	
8	DOPC ASSY	Used only for console with Color monitor
9	TLMC ASSY	Used for console with Color monitor
	TDCB ASSY	Used for console with B/W monitor
10	DSCC ASSY	Used only for console with Color monitor
11	VIDO2 ASSY	Used for Color monitor console without VTR playback memory
	VIPB ASSY	Used for Color monitor console with VTR playback memory (Option)
	VIDM ASSY	Used for console with B/W monitor
12	MPU ASSY	

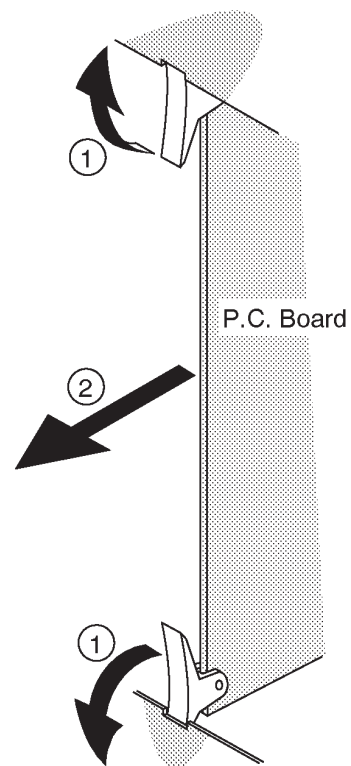

P.C. BOARD(S) REMOVAL

ILLUSTRATION 6-113

■ 6–2–79 Time Keeper RAM (FRU No. 613)**Time Required**

30 Minutes

Tool Required

Screwdriver
IC Remover

Procedure

- Refer to ILLUSTRATION 6–114.
 1. Turn OFF the system.
 - 2. Remove the Side Cover Left (FRU 301). Refer to 6–2–31 on page 6–127.
 3. Unscrew five Nest Cover screws.
 4. Remove the Nest Cover.
 - 5. Remove the MPU Assy (FRU 612). Refer to 6–2–78 on page 6–198.
 6. Remove the Time Keeper RAM mounted on the CPU Assy.

Note

After replacing a time keeper RAM with new one, it is necessary to install the system ID number into the new time keeper RAM and set up two items among four system parameters, Video Signal and Power Frequency.

For system ID installation procedures, refer to Section 4–3–3 (J), SYSTEM ID ENTRY/DISPLAY in chapter 4 of this manual.

For set-up procedures of system preset parameter, refer to LOGIQ™ 400 Proprietary Manual, 2127662.

■ 6-2-79 Time Keeper RAM (FRU No. 613) (continued)

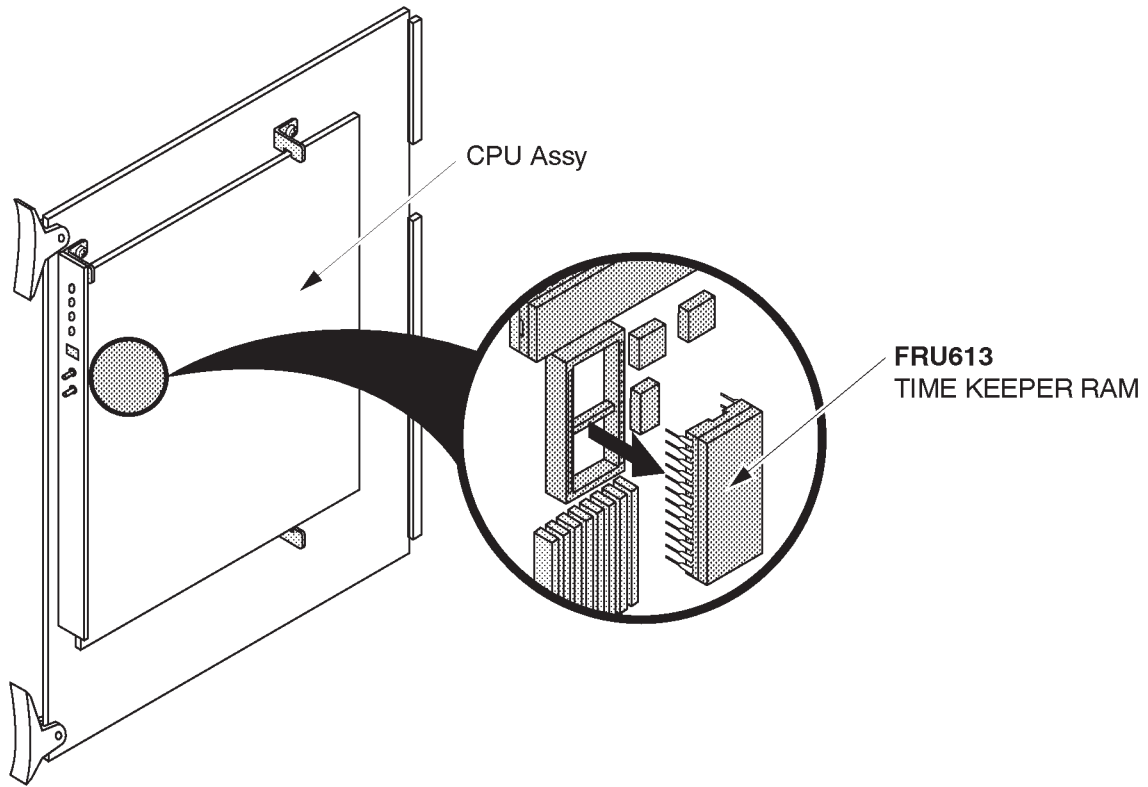

■ TIME KEEPER RAM REMOVAL
ILLUSTRATION 6-114

■ 6-2-80 Time Keeper Battery (FRU No. 613B)**Time Required**

1 Hour

Tool Required

Screwdriver
IC Remover

Procedure

- Refer to ILLUSTRATION 6-115.
 1. Turn OFF the system.
 - 2. Remove the Side Cover Left (FRU 301). Refer to 6-2-31 on page 6-127.
 3. Unscrew the four Nest Cover screws.
 4. Remove the Nest Cover.
 - 5. Remove the MPU Assy (FRU 612). Refer to 6-2-78 on page 6-198.
 6. Remove the Time Keeper Battery.

Note

After replacing a time keeper battery with new one, it is necessary to install the system ID number into the time keeper RAM and to set up the factory preset data.

The LOGIQ™ 400 can be installed the system ID number into new time keeper RAM using the utility function. Refer to Section 4-3-3 (J), SYSTEM ID ENTRY/DISPLAY in Chapter 4 of this manual.

■ 6-2-80 Time Keeper Battery (FRU No. 613B) (continued)

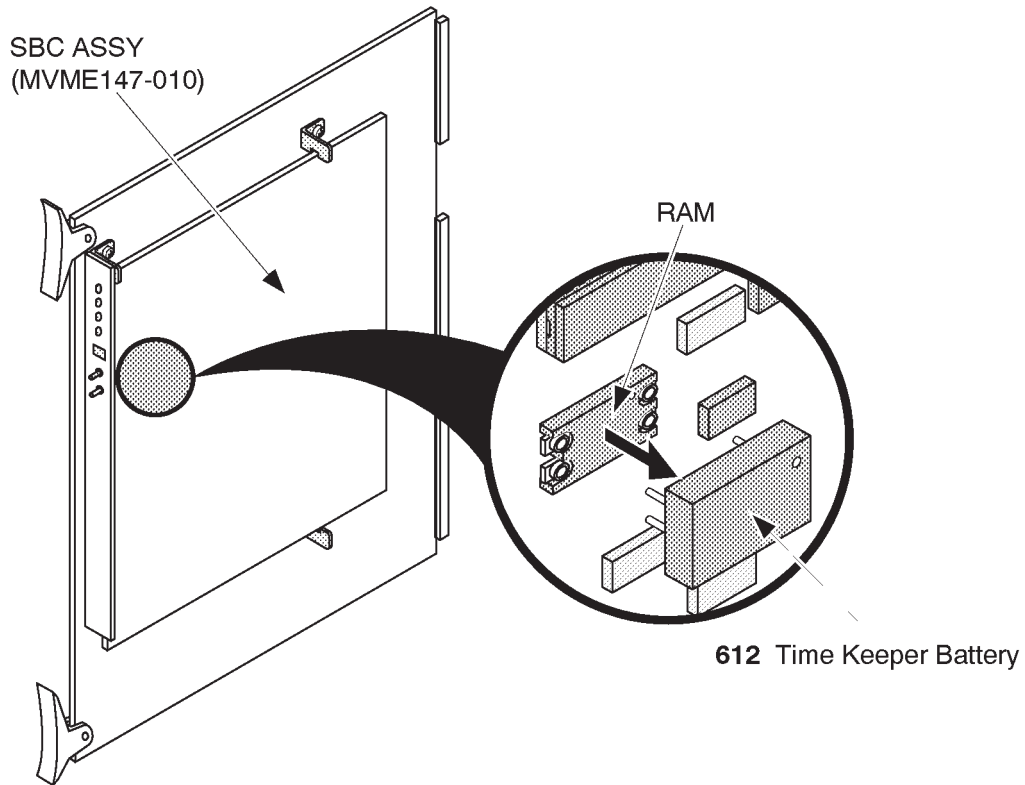

■ TIME KEEPER BATTERY REMOVAL
ILLUSTRATION 6-115

■ 6-2-81 Time Keeper RAM (for MVME167-002B) (FRU No. 613C)**Note**

The MVME167-002B is supplied with the optional DICOM option.

Time Required

1 Hour

Tool Required

Screwdriver
IC Remover

Procedure

- Refer to ILLUSTRATION 6-116 on page 6-205.
 1. Turn OFF the system.
- 2. Remove the Side Cover Left (FRU 301). Refer to 6-2-31 on page 6-127.
- 3. Unscrew the four Nest Cover screws.
- 4. Remove the Nest Cover.
- 5. Remove the CPU-A Assy (FRU 610). Refer to 6-2-78 on page 6-198.
- 6. Remove the Time Keeper RAM on the SBC-A Assy (MVME167-002B).

Note

After replacing a time keeper RAM with new one, it is necessary to install the system ID number into the time keeper RAM and to set up the factory preset data.

6-2-81 Time Keeper RAM (for MVME167-002B) (FRU No. 613C) (continued)

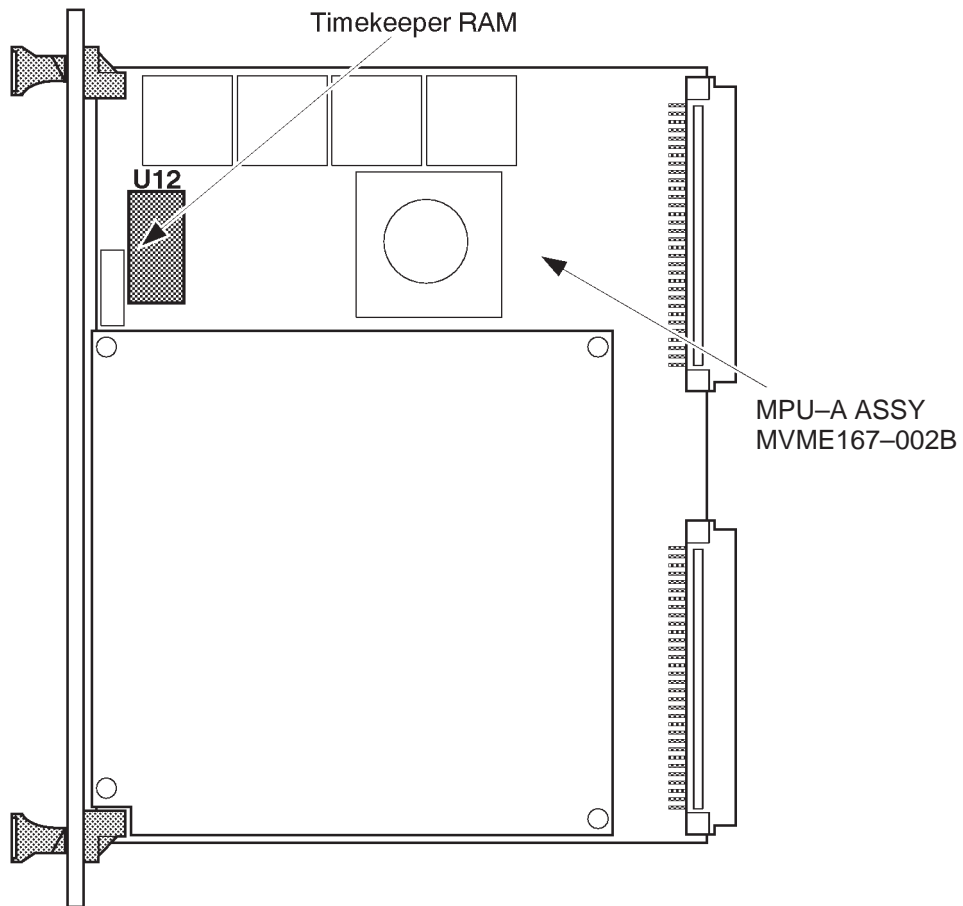

TIME KEEPER RAM (for MVME167-002B) REMOVAL
ILLUSTRATION 6-116

6-2-82 OMEM Assy (FRU No. 614)**Time Required**

30 Minutes

Tool Required

Screwdriver

Procedure

Do not bend or flex the boards when mounting/dismounting the piggyback boards. Surface mount IC boards are very susceptible to damage from flex/torque.

- Refer to ILLUSTRATION 6-117 on page 6-207.
- 1. Turn OFF the system.
- 2. Remove the Side Cover Left (FRU 301). Refer to 6-2-31 on page 6-127.
- 3. Unscrew five Nest Cover screws.
- 4. Remove the Nest Cover.
- 5. Remove the TLMC Assy (FRU 606). Refer to 6-2-78 on page 6-198.
- 6. Unscrew one screw (①).
- 7. Remove the OMEM Assy out of the TLMC Assy.

■ 6-2-82 OMEM Assy (FRU No. 614) (continued)

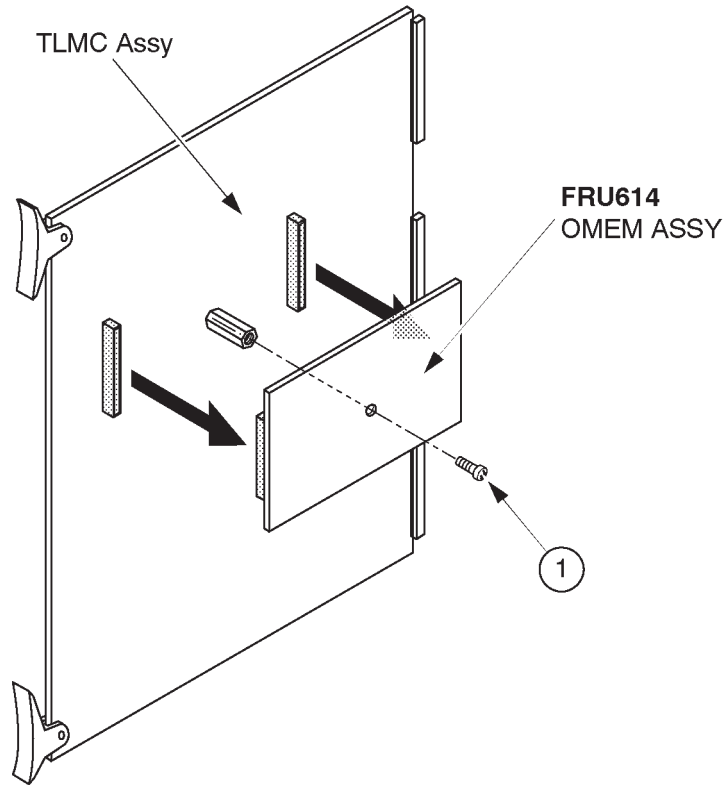

■ OMEM ASSY DISASSEMBLY
ILLUSTRATION 6-117

6-2-83 Nest Mother Assy (FRU No. 615)**Time Required**

2 Hours

Tool Required

Screwdriver
Hexagonal Wrench

Procedure

Refer to ILLUSTRATION 6-118 on page 6-209.

1. Turn OFF the system.
2. Remove the Side Cover Left (FRU 301). Refer to 6-2-31 on page 6-127.
3. Remove the Front Base Cover (FRU 305). Refer to 6-2-35 on page 6-131.
4. Remove the Side Cover Right (FRU 302). Refer to 6-2-32 on page 6-128.
5. Remove the Rear Cover (FRU 303). Refer to 6-2-33 on page 6-129.
6. Remove the Front Cover (FRU 306). Refer to 6-2-36 on page 6-132.
7. Remove the Top Cover (FRU 308). Refer to 6-2-38 on page 6-135.
8. Unscrew five Nest Cover screws.
9. Remove the Nest Cover.
10. Remove all the P.C. Boards. Refer to 6-2-78 on page 6-198.
11. Remove the Rear CONN Panel Assy (FRU 501). Refer to 6-2-61 on page 6-166.
12. Remove the HDD LED Assy (FRU 526). Refer to 6-2-76 on page 6-196.
13. Remove the Power Switch Assy (FRU 527). Refer to 6-2-77 on page 6-197.
14. Remove the Probe CONN Set Assy (FRU 512/513). Refer to 6-2-68 on page 6-176.
15. Remove the Nest Fan Assy (FRU 511). Refer to 6-2-67 on page 6-174.
16. Remove the Neck Assy (FRU 201/202). Refer to 6-2-26 on page 6-114.
17. Disconnect thirteen connectors connected with the mother board.

■ **6-2-83 Nest Mother Assy (FRU No. 615) (continued)**

21. Unscrew four hexagonal bolts (① – ③) on the left side of the console.
22. Unscrew three hexagonal bolts (④ – ⑥) on the right side of the console.
23. Remove the Nest Mother Assy (FRU No. 615).

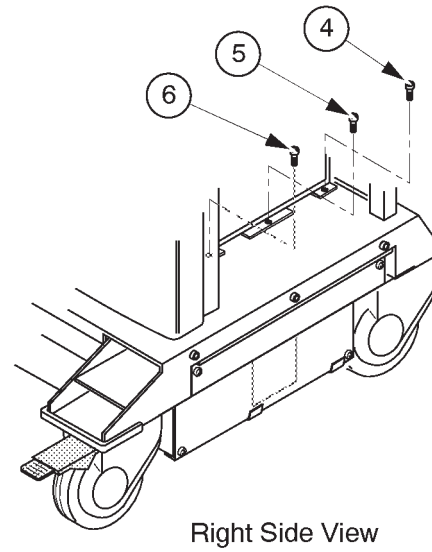
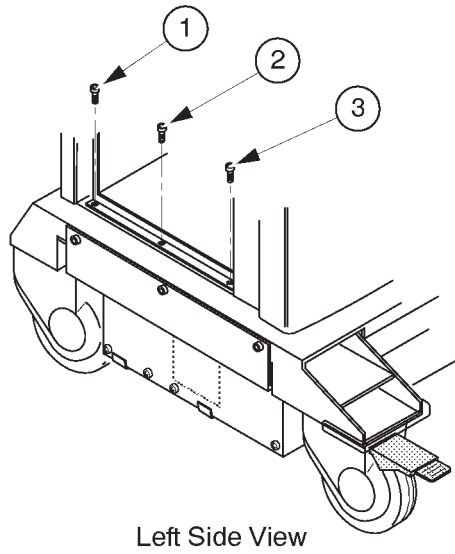

■ **NEST MOTHER ASSY DISASSEMBLY**
ILLUSTRATION 6-118

6-2-84 Mother IC (FRU No. 616)**Time Required**

1 Hour

Tool Required

Screwdriver

Hexagonal Wrench

Procedure

Refer to ILLUSTRATION 6-119 on page 6-211.

1. Turn OFF the system.
2. Remove the Front Base Cover (FRU 305). Refer to 6-2-35 on page 6-131.
3. Remove the Side Cover Right (FRU 302). Refer to 6-2-32 on page 6-128.
4. Remove the Rear Cover (FRU 303). Refer to 6-2-33 on page 6-129.
5. Remove the Neck Assy (FRU 201). Refer to 6-2-26 on page 6-114.
6. Remove the Mother IC.

■ 6-2-84 Mother IC (FRU No. 616) (continued)

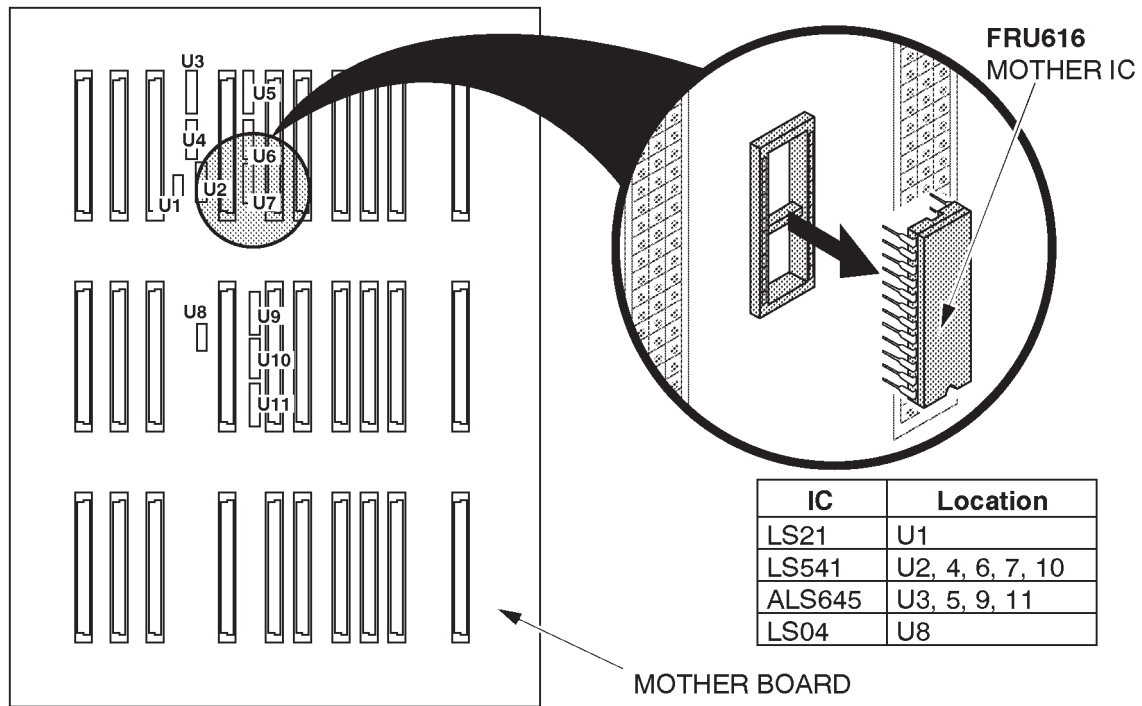

■ **MOTHER IC REMOVAL**
ILLUSTRATION 6-119

This page is left blank intentionally.

This page is left blank intentionally.

6-2-85 High Voltage Assy (FRU No. 701)**Time Required**

30 Minutes

Tool Required

Screwdriver

Procedure

Refer to ILLUSTRATION 6-120 on page 6-215.

1. Turn OFF the system and unplug the main power cord.
2. Remove the Front Base Cover (FRU 305). Refer to 6-2-35 on page 6-131.
3. Remove the Side Cover Right (FRU 302). Refer to 6-2-32 on page 6-128.
4. Unscrew four screws (① – ④).
5. Remove the PS Cover Right.
6. Unscrew two screws (⑤ and ⑥).
7. Disconnect five connectors (⑦ – ⑪).
8. Pull the High Voltage Assy out.
9. Disconnect the HV Fan Cable (⑫).
10. Remove the High Voltage Assy.

■ 6-2-85 High Voltage Assy (FRU No. 701) (continued)

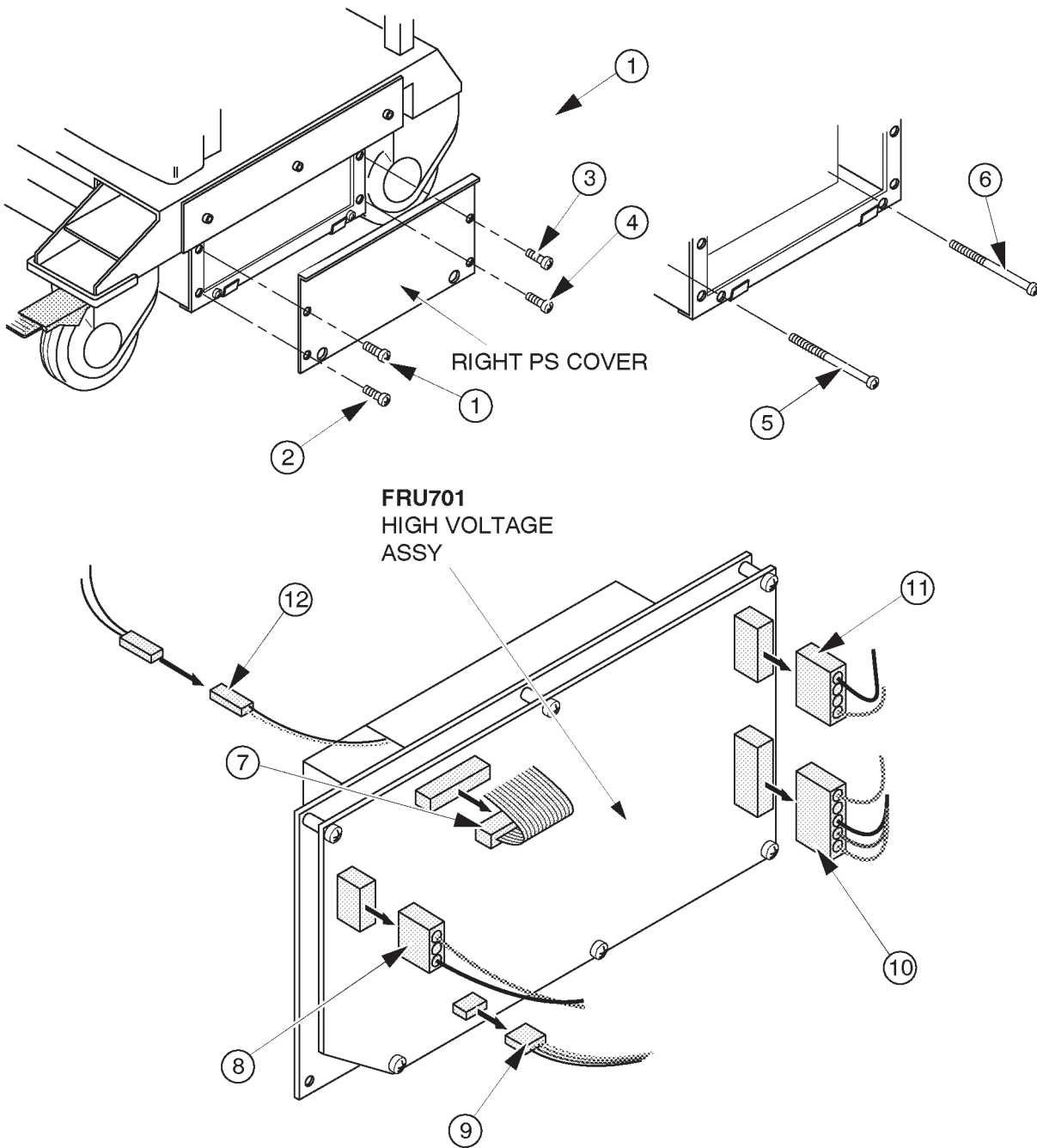

HIGH VOLTAGE ASSY DISASSEMBLY
ILLUSTRATION 6-120

■ 6-2-86 HV Fan (FRU No. 702)

Time Required

30 Minutes

Tool Required

Screwdriver

Procedure

■ Refer to ILLUSTRATION 6-121.

1. Turn OFF the system and unplug the main power cord.
- 2. Remove the High Voltage Assy (FRU 701). Refer to 6-2-85 on page 6-214.
3. Unscrew four screws (① – ④).
4. Remove the HV Fan.

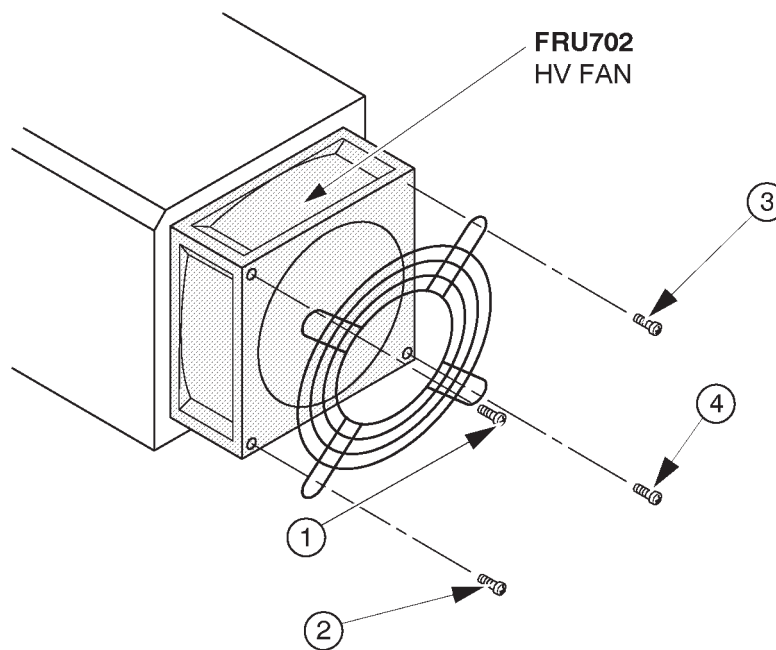

■ HV FAN DISASSEMBLY
ILLUSTRATION 6-121

This page is left blank intentionally.

■ 6–2–87 Low Voltage Unit (FRU No. 703)**Time Required**

30 Minutes

Tool Required

Screwdriver

Procedure

- Refer to ILLUSTRATION 6–122 on page 6–219.
 1. Turn OFF the system and unplug the main power cord.
 - 2. Remove the Side Cover Left (FRU 301). Refer to 6–2–31 on page 6–127.
 3. Unscrew four screws (① – ④).
 4. Remove the Left PS Cover.
 5. Unscrew two screws (⑤ and ⑥).
 6. Pull the Low Voltage Unit outwards.
 7. Unscrew fifteen screws (⑦ – ⑳) to remove wires.
 8. Pull the Low Voltage Unit out.
 - 9. Remove the Plastic Cover as shown in ILLUSTRATION 6–122 on page 6–219.
 10. Disconnect one connector (㉒).
 11. Unscrew two screws (㉓ and ㉔) to remove the FG wires.
 12. Remove the Low Voltage Unit.

6-2-87 Low Voltage Unit (FRU No. 703) (continued)

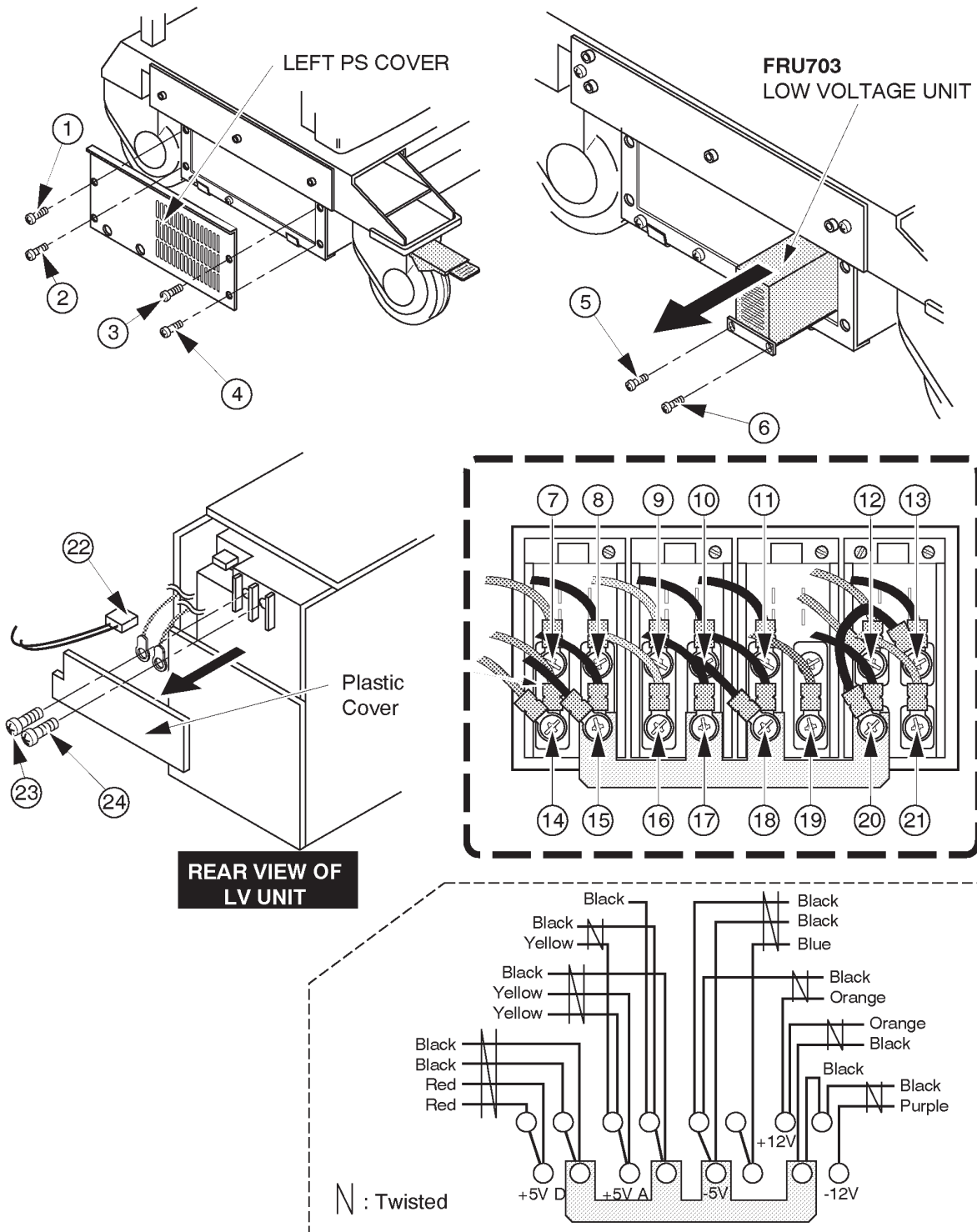

REAR VIEW OF LV UNIT

LOW VOLTAGE UNIT DISASSEMBLY

ILLUSTRATION 6-122

6-2-88 Power Control Unit (FRU No. 704)**Time Required**

30 Minutes

Tool Required

Screwdriver

Procedure

- Refer to ILLUSTRATION 6-123 on page 6-221.
 1. Turn OFF the system and unplug the main power cord.
 - 2. Remove the Side Cover Left (FRU 301). Refer to 6-2-31 on page 6-127.
 - 3. Remove the Left PS Cover. Refer to 6-2-87 on page 6-218.
 4. Unscrew two screws (① and ②).
 5. Disconnect eight connectors on the Power Control Unit (③ and ⑩).
 6. Remove the Power Control Unit.

6-2-88 Power Control Unit (FRU No. 704) (continued)

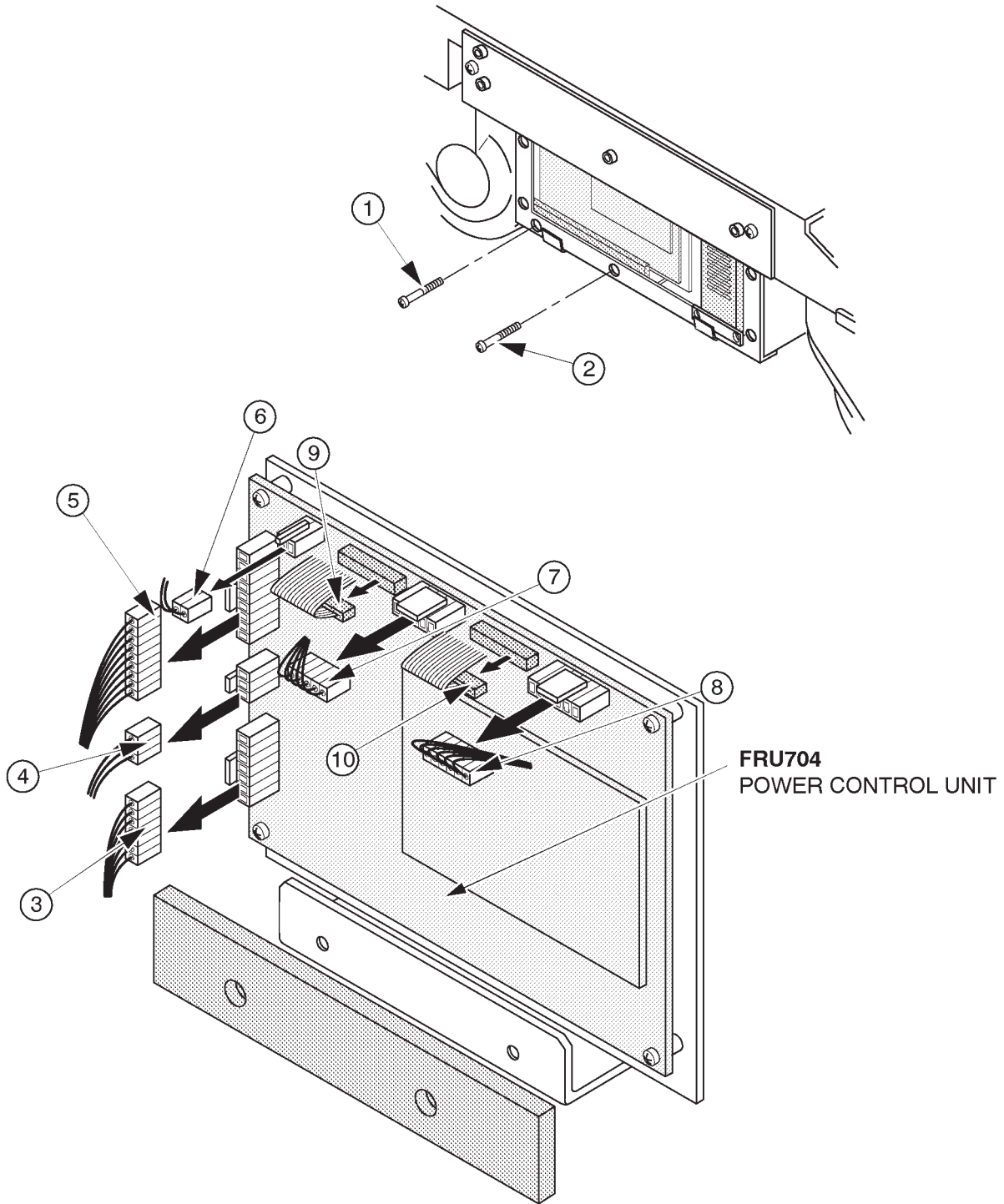

POWER CONTROL UNIT DISASSEMBLY
ILLUSTRATION 6-123

■ 6-2-89 SSR Unit (FRU No. 705)**Time Required**

30 Minutes

Tool Required

Screwdriver

Procedure

- Refer to ILLUSTRATION 6-124 on page 6-223.
 1. Turn OFF the system and unplug the main power cord.
- 2. Remove the Power Control Unit (FRU 704). Refer to 6-2-88 on page 6-220.
 3. Unscrew two screws (① and ②).
 4. Pull the SSR Unit outwards.
 5. Unscrew eight screws (③ – ⑩) to remove eight wires.
 6. Pull four crimp contacts (⑪ – ⑭) out of the SSR Unit.
 7. Remove the SSR Unit.

6-2-89 SSR Unit (FRU No. 705) (continued)

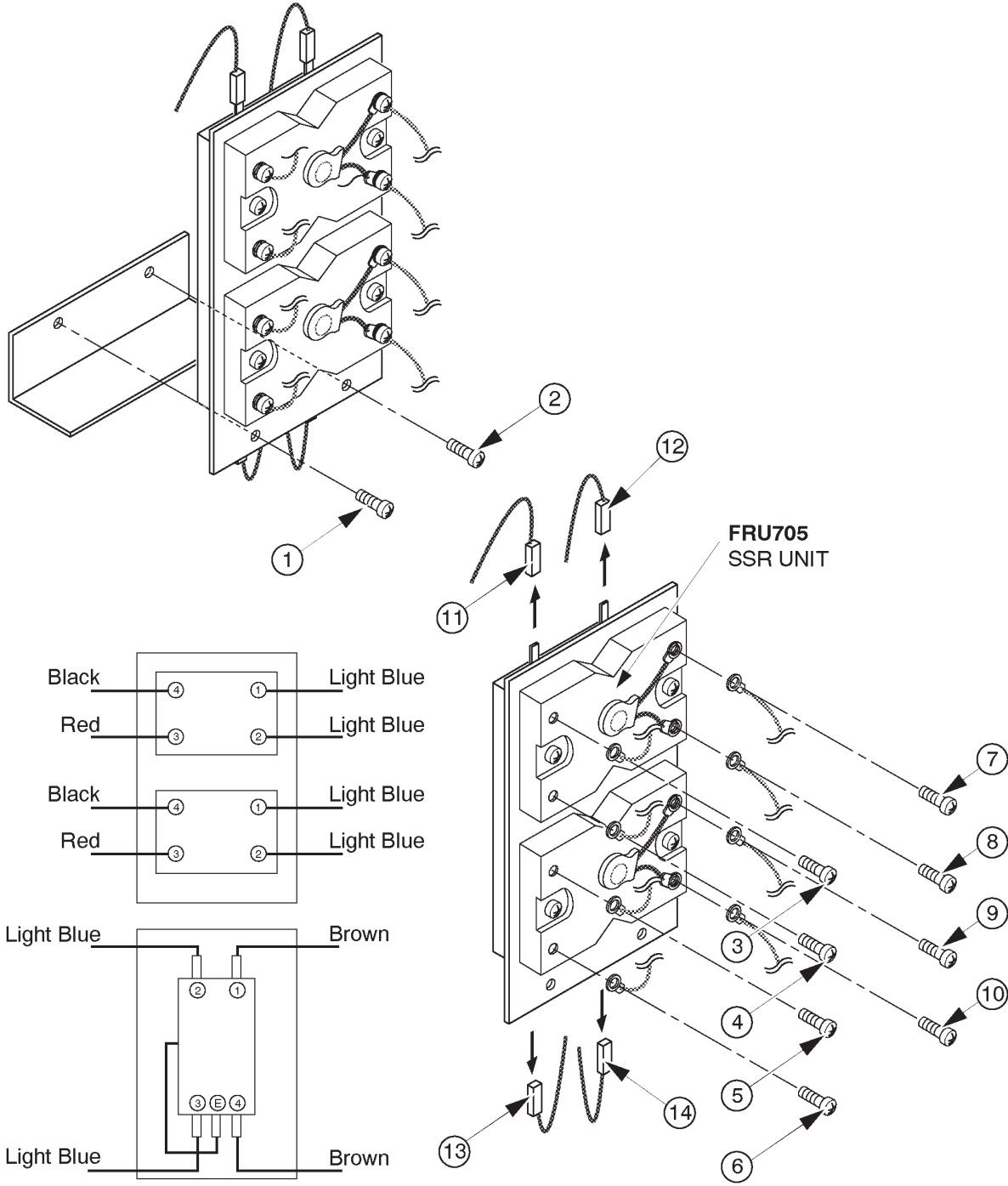

SSR UNIT DISASSEMBLY
ILLUSTRATION 6-124

■ 6-2-90 Power Inlet Unit (FRU No. 706 for 115V, FRU No. 707 for 220V)**Time Required**

15 Minutes

Tool Required

Screwdriver

Procedure

- Refer to ILLUSTRATION 6-125 on page 6-225.
 1. Turn OFF the system and unplug the main power cord.
- 2. Remove the Rear Cover (FRU 303). Refer to 6-2-33 on page 6-129.
 3. Unscrew six screws (① – ⑥).
 4. Pull the Power Inlet Unit out.
 5. Disconnect one connector (⑦) .
 6. Unscrew two screws (⑧ and ⑨) to remove two FG wires.
 7. Remove the Power Inlet Unit.

■ 6-2-90 Power Inlet Unit (FRU No. 706 for 115V, FRU No. 707 for 220V) (continued)

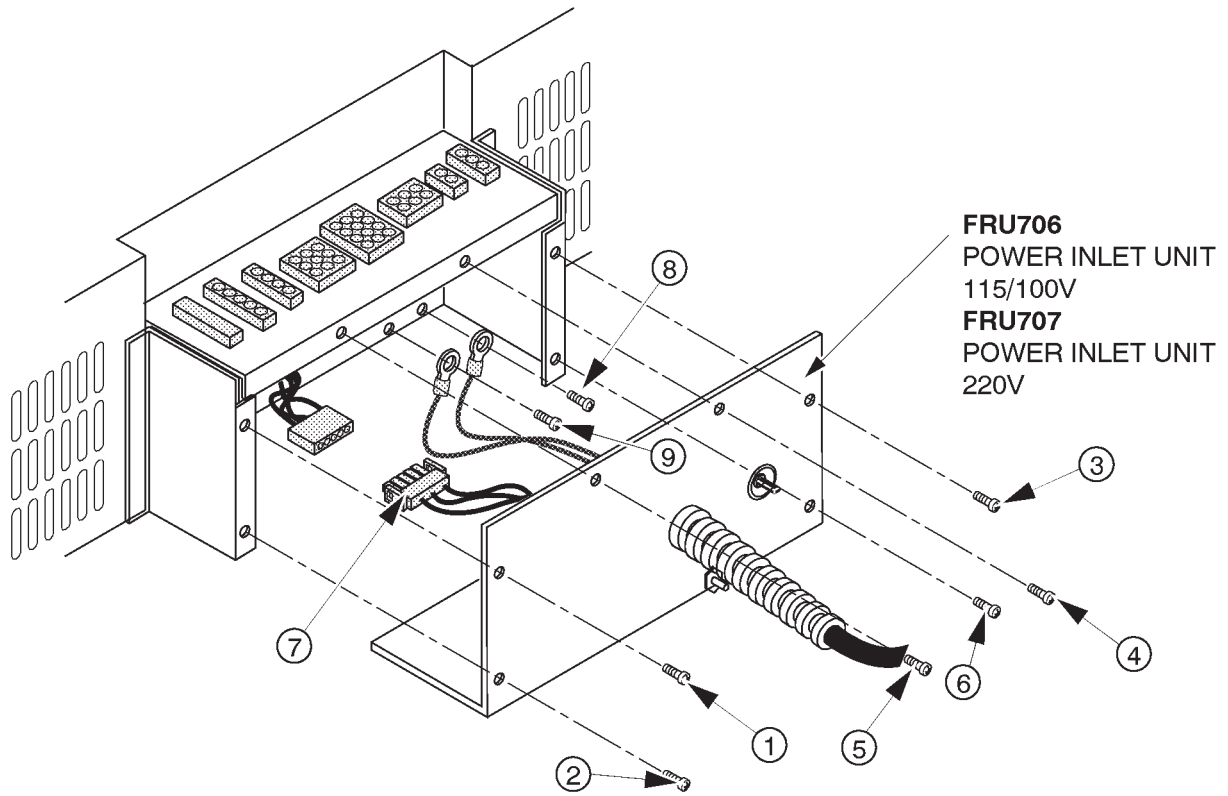

POWER INLET UNIT DISASSEMBLY
ILLUSTRATION 6-125



6-2-91 PW Air Filter (FRU No. 708)**Time Required**

5 Minutes

Tool Required

Not necessary

Procedure**Refer to ILLUSTRATION 6-126.**

1. Turn OFF the system and unplug the main power cord.
2. Remove the Retainer.
3. Remove the PW Air Filter.

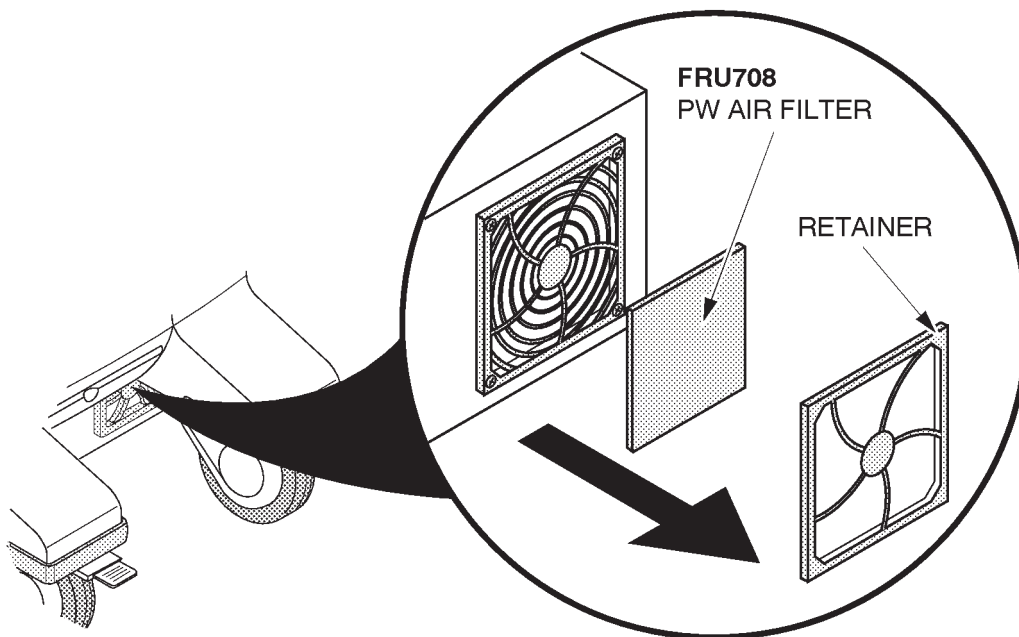

PW AIR FILTER REMOVAL
ILLUSTRATION 6-126

6-2-92 Filter Cover Set (FRU No. 709)**Time Required**

10 Minutes

Tool Required

Screwdriver

Procedure**Refer to ILLUSTRATION 6-127.**

1. Turn OFF the system and unplug the main power cord.
2. Remove the PW Air Filter.
3. Unscrew four screws (① – ④).
4. Remove the Guard.

Note

The Filter Cover Set includes Retainer, PW Air Filter, and Guard.

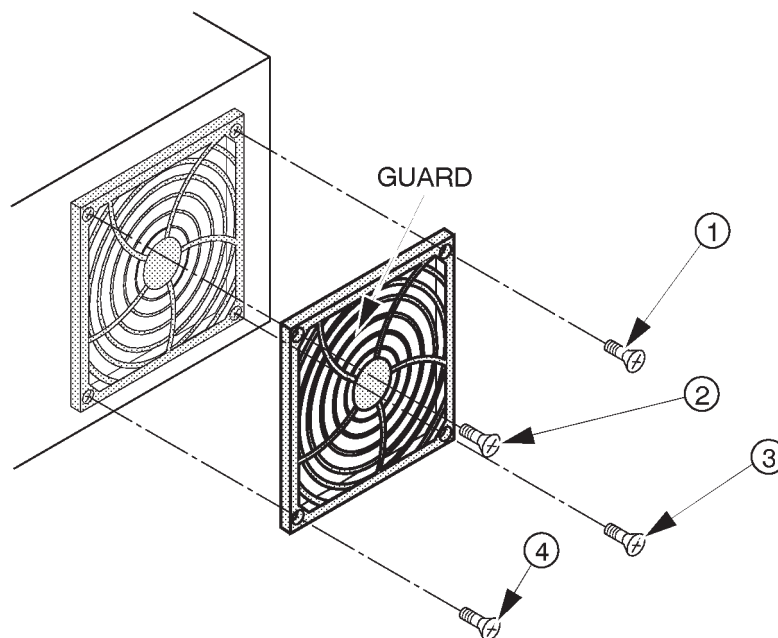

FILTER COVER SET DISASSEMBLY
ILLUSTRATION 6-127

This page is left blank intentionally.

This page is left blank intentionally.

6-2-93 HV Unit (FRU No. 750)**Time Required**

30 Minutes

Tool Required

Screwdriver

Procedure

- Refer to ILLUSTRATION 6-128 on page 6-231.
 1. Turn OFF the system and unplug the main power cord.
 - 2. Remove the Front Base Cover (FRU 305). Refer to 6-2-35 on page 6-131.
 - 3. Remove the Side Cover Right (FRU 302). Refer to 6-2-32 on page 6-128.
 4. Unscrew four screws (① – ④).
 5. Remove the RIGHT PS COVER.
 6. Unscrew three screws (⑤ – ⑦).
 7. Disconnect one flat cable (⑧) from the PCONT ASSY on the HV Unit.
 8. Pull the HV Unit outwards.
 9. Disconnect eight (8) connectors (⑨ – ⑯) out of the HV Unit.
 10. Remove the HV Unit (FRU 750).

6-2-93 HV Unit (FRU No. 750) (continued)

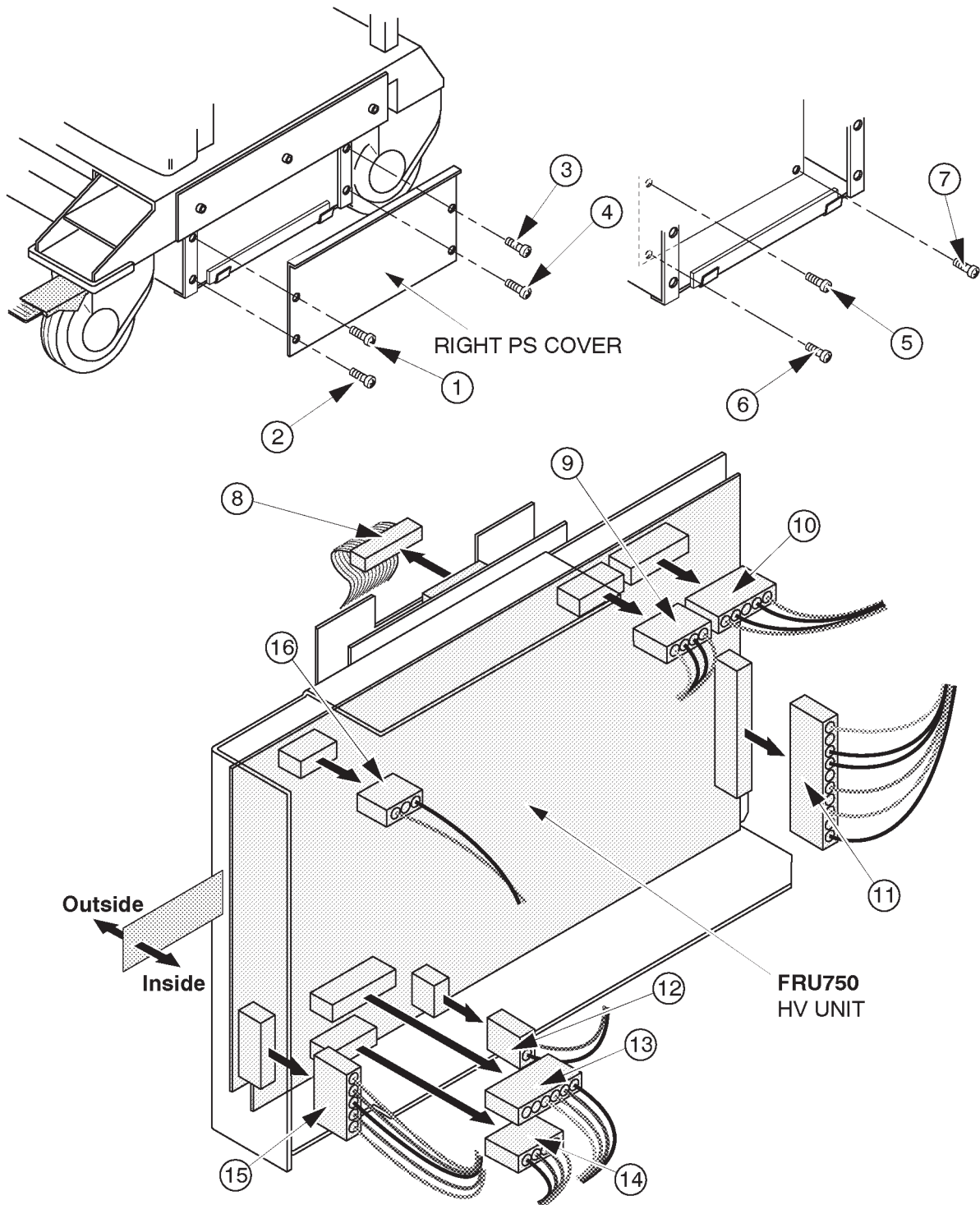

HV UNIT DISASSEMBLY
ILLUSTRATION 6-128

6-2-94 Cooling Fan (FRU No. 751)**Time Required**

15 Minutes

Tool Required

Screwdriver

Procedure

1. Turn OFF the system and unplug the main power cord.
2. Remove the Side Cover Left. Refer to 6-2-31 on page 6-127.
3. Remove the Left PS Cover. Refer to 6-2-95 on page 6-234.
4. Unscrew four screws (① – ④).
5. Pull the Cooling fan outwards.
6. Disconnect the cooling fan connector (⑤).
7. Remove the Cooling Fan.

**COOLING FAN DISASSEMBLY**

ILLUSTRATION 6-129

This page is left blank intentionally.

6-2-95 LV2 Unit (FRU No. 752)**Time Required**

30 Minutes

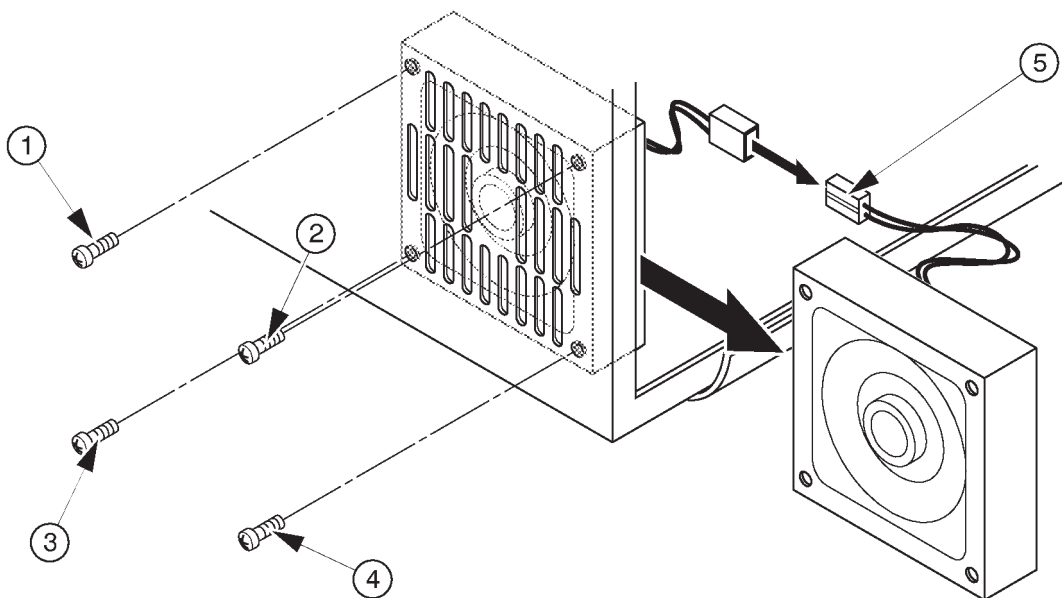
Tool Required

Screwdriver

Procedure

- Refer to ILLUSTRATION 6-131 on page 6-235.
1. Turn OFF the system and unplug the main power cord.
- 2. Remove the Side Cover left. Refer to 6-2-31 on page 6-127.
3. Unscrew four screws (① – ④).
4. Remove the Left PS Cover.
5. Unscrew two screws (⑤ and ⑥).
6. Unscrew fourteen (14) screws (⑦ – ⑳) to remove wires.
7. Disconnect five connectors (㉑ – ㉕).
8. Pull the LV2 Unit outwards.
9. Disconnect one connector (㉖) from the rear of LV2 Unit.
10. Unscrew three screws (㉗ – ㉙).
11. Remove the LV2 Unit.

Note

When replacing the LV2 Unit, re-use the metal bracket installed onto the LV2 Unit.

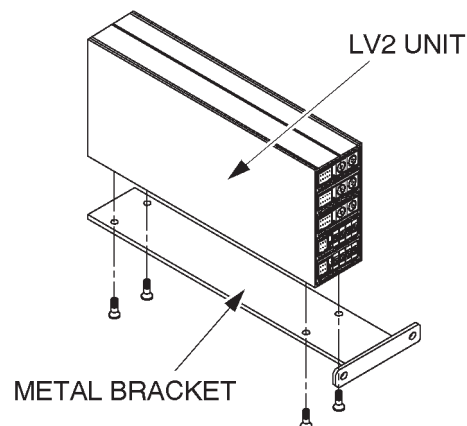

LV2 UNIT REMOVAL
ILLUSTRATION 6-130

6-2-95 LV2 Unit (FRU No. 752) (continued)

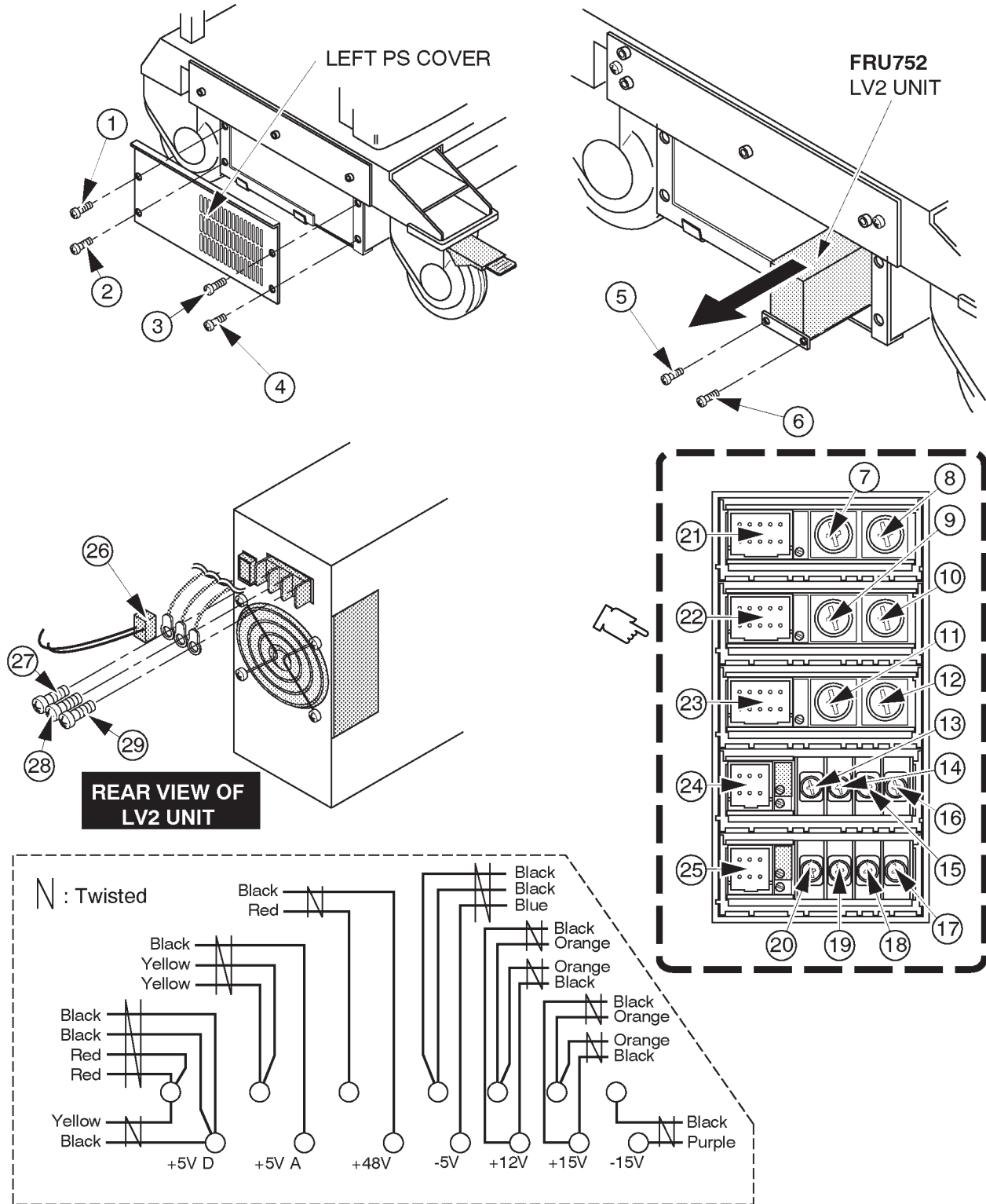

6-2-96 TRIAC Unit (FRU No. 753)**Time Required**

10 Minutes

Tool Required

Screwdriver

Procedure

- Refer to ILLUSTRATION 6-132 on page 6-237.
 1. Turn OFF the system and unplug the main power cord.
 2. Remove the Side Cover left. Refer to 6-2-31 on page 6-127.
 3. Remove the Left PS Cover. Refer to 6-2-95 on page 6-234.
 4. Unscrew two screws (① and ②).
 5. Disconnect eleven (11) connectors (③ – ⑬) from the component side of the TRIAC Unit.
 6. Pull the TRIAC Unit outwards.
 7. Disconnect five connectors (⑭ – ⑱) from the NF2 located on the back side of the TRIAC Unit.
 8. Disconnect two connectors (⑲ and ⑳) from the rear of fuse socket.
 9. Remove the TRIAC Unit.

6-2-96 TRIAC Unit (FRU No. 753) (continued)

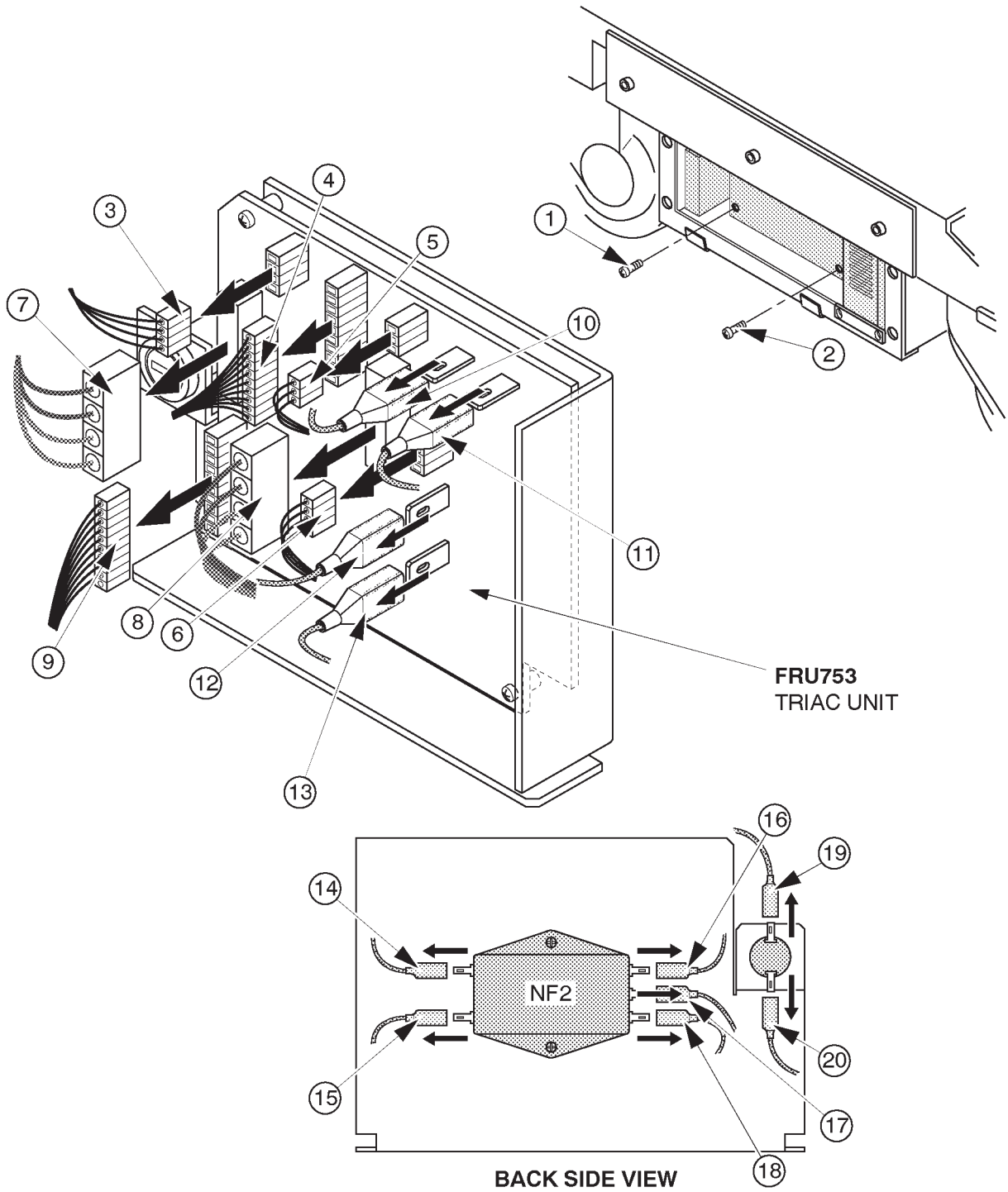

TRIAC UNIT DISASSEMBLY
ILLUSTRATION 6-132

■ 6-2-97 Power Inlet Unit2 (FRU No. 754 for 115V, FRU No. 755 for 220V)**Time Required**

15 Minutes

Tool Required

Screwdriver

Procedure

- Refer to ILLUSTRATION 6-133 on page 6-239.
 1. Turn OFF the system and unplug the main power cord.
- 2. Remove the Rear Cover (FRU 303). Refer to 6-2-33 on page 6-129.
 3. Unscrew six screws (① – ⑥).
 4. Pull the Power Inlet Unit out.
 5. Disconnect one connector (⑦) .
 6. Unscrew two screws (⑧ and ⑨) to remove two FG wires.
 7. Remove the Power Inlet Unit2.

6-2-97 Power Inlet Unit2 (FRU No. 754 for 115V, FRU No. 755 for 220V) (continued)

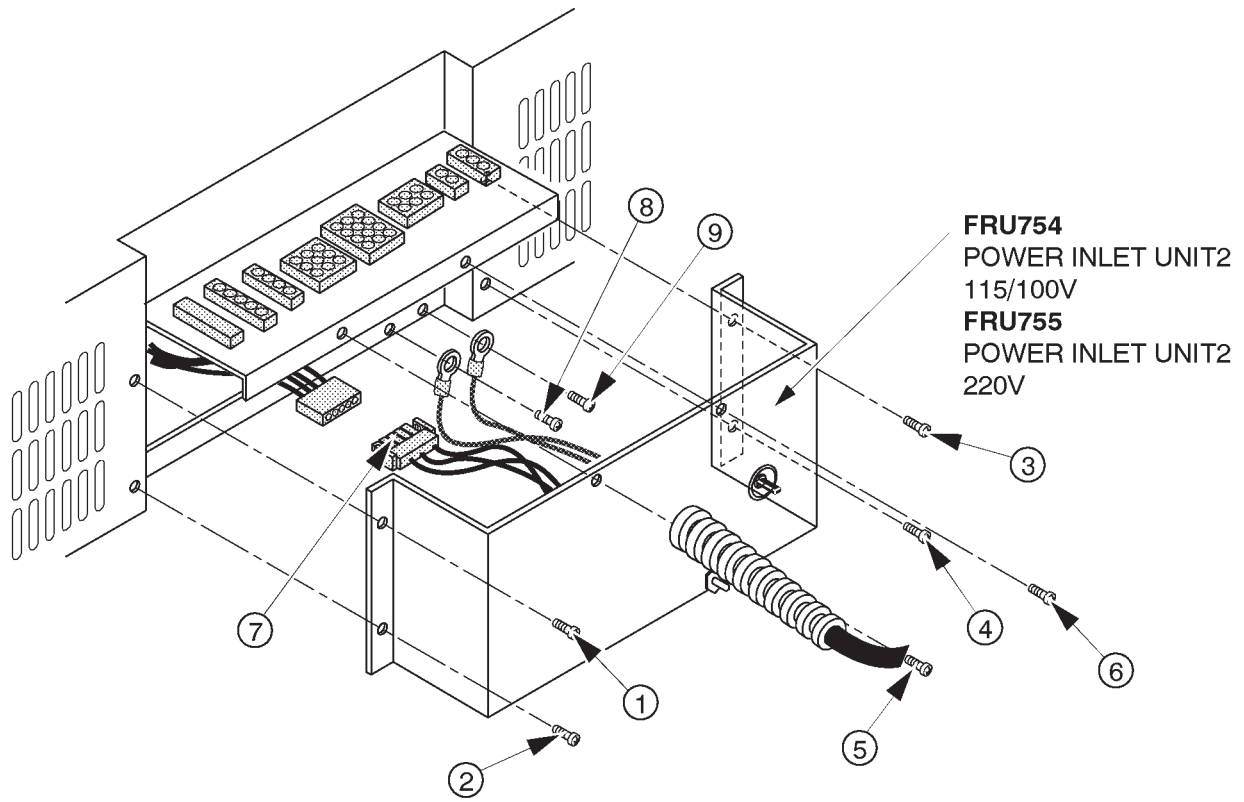

POWER INLET UNIT2 DISASSEMBLY
ILLUSTRATION 6-133

6-2-98 LV3 Unit (FRU No. 770)

Time Required

30 Minutes

Tool Required

Screwdriver

Procedure

Refer to ILLUSTRATION 6-135 on page 6-241.

1. Turn the LOGIQ™ 400 system power OFF.
2. Remove the Side Cover left.
3. Unscrew four screws (① – ④).
4. Remove the Left PS Cover.
5. Unscrew two screws (⑤ and ⑥).
6. Disconnect one connector (⑦) .
7. Unscrew fourteen screws (⑧ – ⑳).
8. Pull the LV3 Unit Outwards.
9. Disconnect one connector (㉒) from the rear of LV3 Unit.
10. Unscrew three screws (㉓ – ㉕).
11. Remove the LV3 Unit.

Note

When installing the LV3 Unit, it is necessary to remove the HV Unit temporarily. Refer to section 6-7 "REPLACING LV2 UNIT WITH LV3 UNIT" on page 6-276.

Note

When replacing the LV3 Unit, re-use the metal bracket installed onto the LV3 Unit.

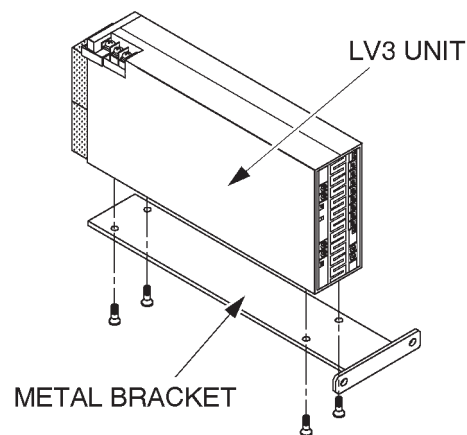

SHORT PLUG AND FG WIRE

ILLUSTRATION 6-134

6-2-98 LV3 Unit (FRU No. 770) (continued)

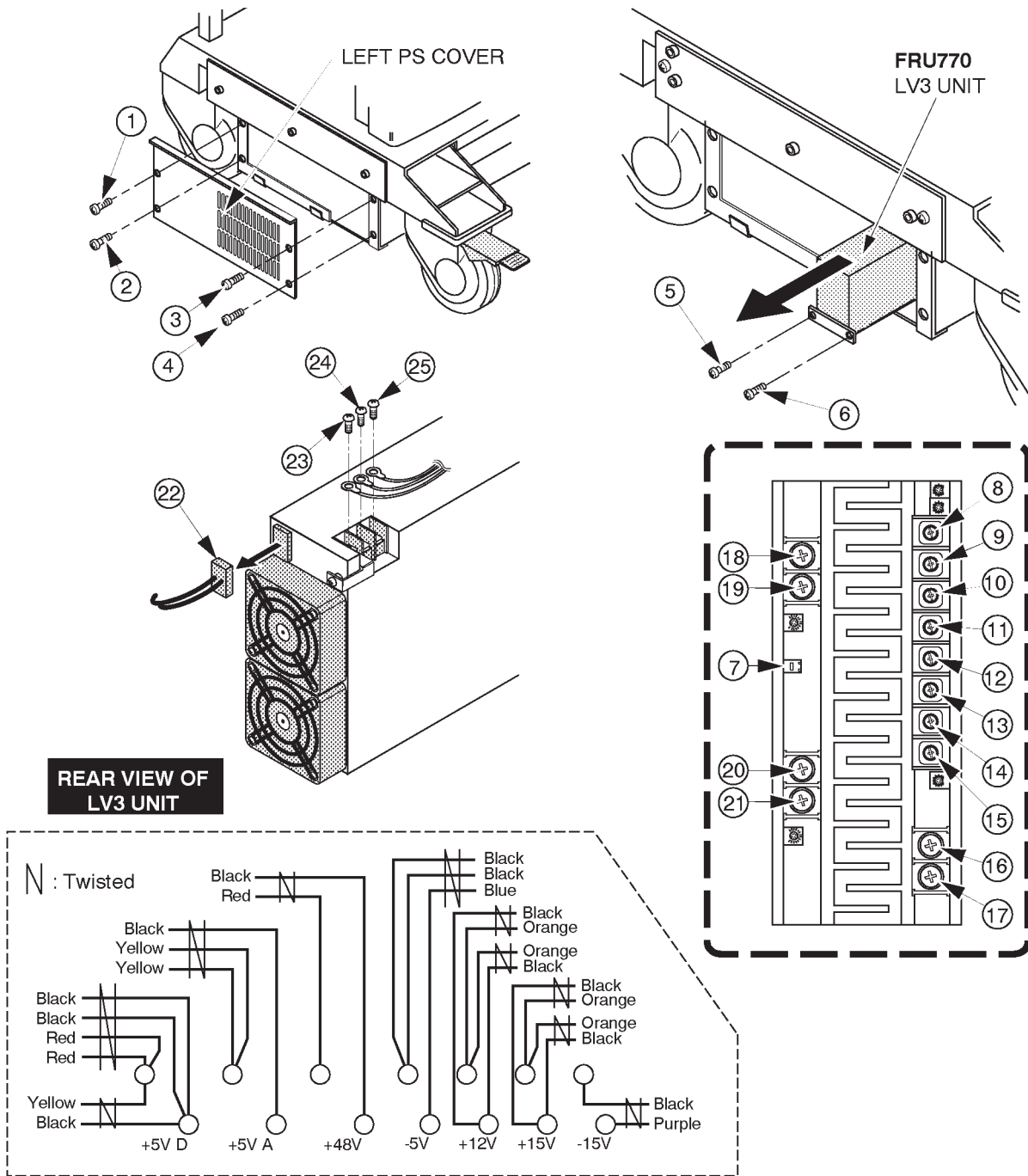

This page is left blank intentionally.

6-3 FUSE REPLACEMENT

6-3-1 Introduction

LOGIQ™ 400 has two types of Power Supply Unit, Power Supply Unit and Power Supply Unit2. The fuses used are different between both units.

Old power supply unit (2126982 for 115V and 2126981 for 220V) has three replaceable fuses. The table below states the items of those fuses.

TABLE 6-1
REPLACEABLE FUSES FOR POWER SUPPLY UNIT

LOCATION	Ref. No.	RATING		REMARKS
TRDR ASSY	F501	3.2A	250V	Refer to 6-3-2 (A)
CNTIF ASSY	F1	1.0A	250V	Refer to 6-3-2 (B)
Power Supply Unit	F1	5A	300V	Refer to 6-3-2 (C)

New power supply unit2 (2144481 for 115V and 2144480 for 220V) has three replaceable fuses. The table below states the items of those fuses.

TABLE 6-2
REPLACEABLE FUSES FOR POWER SUPPLY UNIT2

LOCATION	Ref. No.	RATING		REMARKS
TRIAC ASSY	F301	20A	32V	Refer to 6-3-2 (D)
TRIAC ASSY	F302	25A	32V	Refer to 6-3-2 (D)
TRIAC ASSY	F303	3A	250V	Refer to 6-3-2 (D)

Concerning replacing each fuse of LOGIQ™ 400, refer to the following steps;

Note

This system contains no operator serviceable parts inside. Please refer servicing to qualified personnel from GE. (See Address of Chapter 1.)

6-3-2 Replacement Procedures

Parts Required

For Power Supply Unit:

FRU	PART NAME	QTY	PART #	REMARKS
801	Fuse Set	1	2135619	

For Power Supply Unit2:

FRU	PART NAME	QTY	PART #	REMARKS
801B	Fuse Set 2	1	2144490	

Tools Required

Screwdriver

6-3-2 Replacement Procedures (continued)**(A) F1 on TRDR Assy**

1. Turn the system power OFF. Follow the OSHA Lockout/Tagout Requirements (29 CFR 1910.147, Direction 46-015902).
2. Remove the Side Cover Left. Refer to 6-2-31 on page 6-127.
3. Unscrew five screws and remove the Nest Cover. Refer to 6-2-78 on page 6-198.
4. Pull the TRDR Assy out of slot 1. Refer to 6-2-78 on page 6-198.
5. Replace the defective fuse with new one. Make sure that only fuse with the required rated current and of same type is used for replacement. For the removal of the F1 fuse, refer to ILLUSTRATION 6-136.
6. After replacing Fuse, re-install the TRDR Assy, Nest Cover, and Side Cover Left.

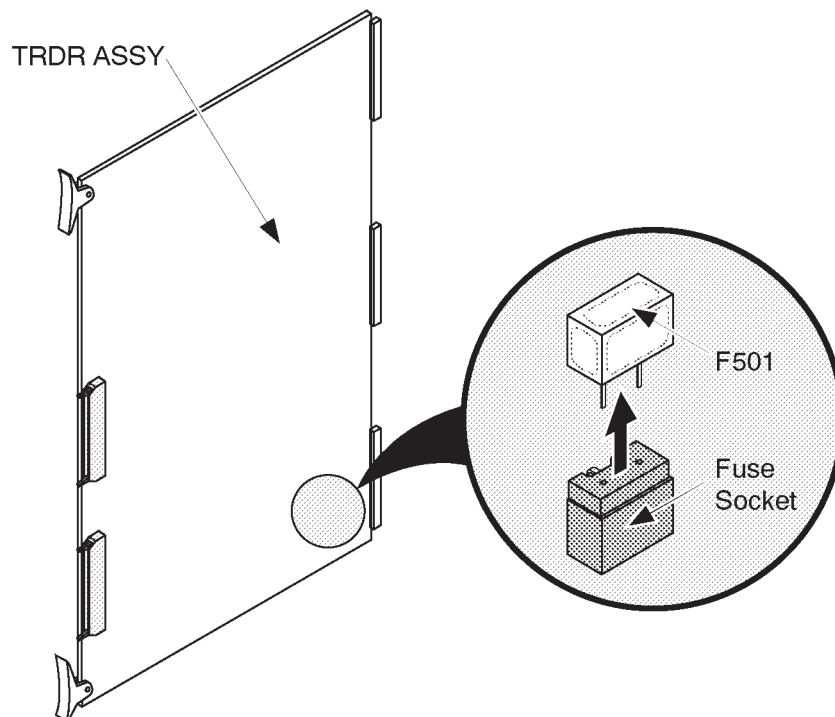

REMOVING FUSE (F501) ON TRDR ASSY
ILLUSTRATION 6-136

6-3-2 Replacement Procedures (continued)**(B) F1 on CNTIF Assy**

1. Turn the system power OFF. Follow the OSHA Lockout/Tagout Requirements (29 CFR 1910.147, Direction 46-015902).
2. Remove the Rear Cover. Refer to 6-2-33 on page 6-129.
3. Remove the Rear CONN Panel Assy. Refer to 6-2-61 on page 6-166.

Note

It is not necessary to disconnect cables in order to replace the fuse.

4. Replace the defective fuse with new one. Make sure that only fuse with the required rated current and of same type are used for replacement.
5. After replacing Fuse, re-install the Rear CONN Panel Assy and Rear Cover.

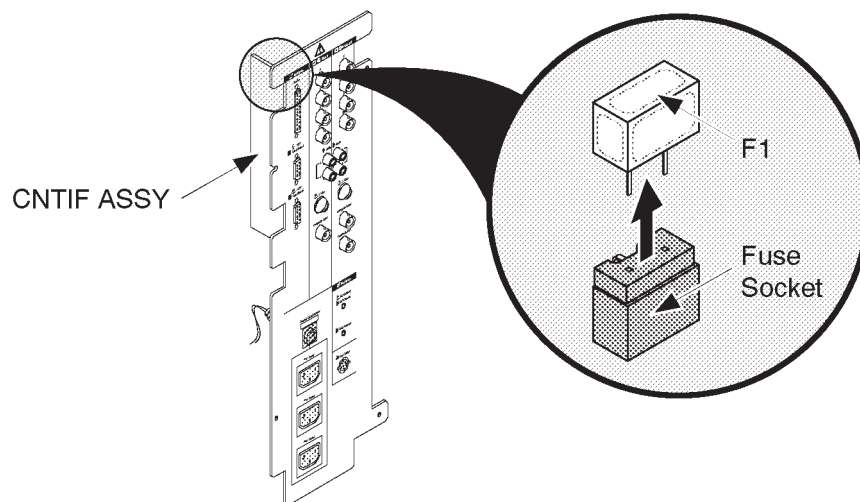

REMOVING FUSE (F1) ON CNTIF ASSY
ILLUSTRATION 6-137

6-3-2 Replacement Procedures (continued)**(C) F1 in PS Unit**

1. Turn the system power OFF. Follow the OSHA Lockout/Tagout Requirements (29 CFR 1910.147, Direction 46-015902).
2. Remove the Side Cover Left. Refer to 6-2-31 on page 6-127.
3. Remove the Left PS Cover. Refer to 6-2-87 on page 6-218.
4. Remove the Power Control Unit. Refer to 6-2-88 on page 6-220.
5. Turn the cap 90 degrees counterclockwise and remove the defective fuse as shown in ILLUSTRATION 6-138.
6. Install the new fuse. Make sure that only fuse with the required rated current and of same type is used for replacement.
7. After replacing Fuse, re-install the Power Control Unit, Left PS Cover, and the Side Cover Left.

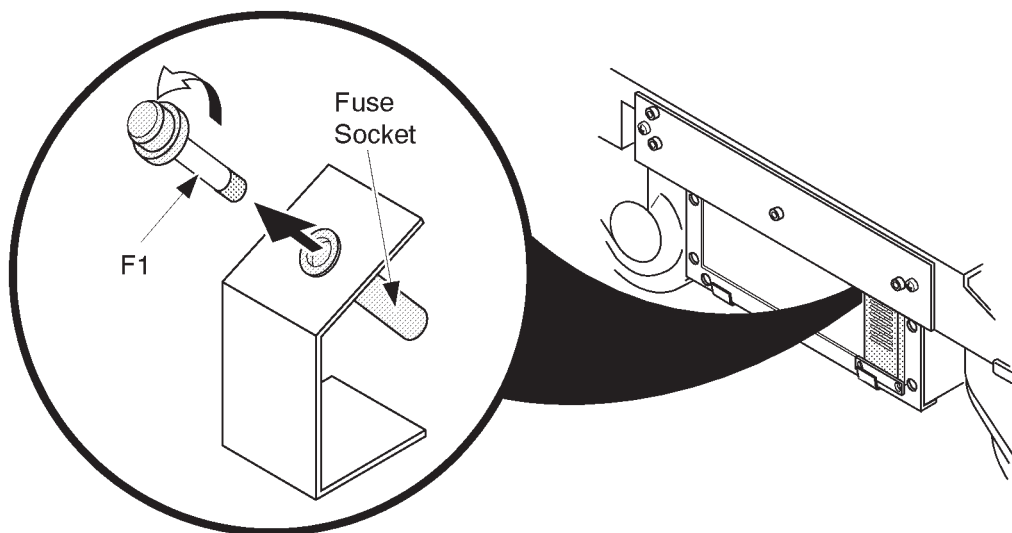

FUSE F1 REMOVAL
ILLUSTRATION 6-138

6-3-2 Replacement Procedures (continued)**(D) Fuses on TRIAC Unit of PS Unit2**

1. Turn the system power OFF. Follow the OSHA Lockout/Tagout Requirements (29 CFR 1910.147, Direction 46-015902).
2. Remove the Side Cover Left. Refer to 6-2-31 on page 6-127.
3. Remove the Left PS Cover. Refer to 6-2-87 on page 6-218.
4. Remove the defective fuse(s) located on the TRIAC Unit.

To remove the F301 or F302:

- i. Pull the defective fuse from the fuse socket on the TRIAC Unit. Refer to ILLUSTRATION 6-139 on page 6-249.

To remove the F303:

- ii. Turn the cap 90 degrees counterclockwise and pull the cap with the F303 fuse out.
Refer to ILLUSTRATION 6-139 on page 6-249.

5. Install the new fuse. Make sure that only fuse with the required rated current and of same type is used for replacement.
6. After replacing fuses, re-install the Left PS Cover and the Side Cover Left.

6-3-2 Replacement Procedures (continued)

(D) Fuses on TRIAC Unit of PS Unit2 (continued)

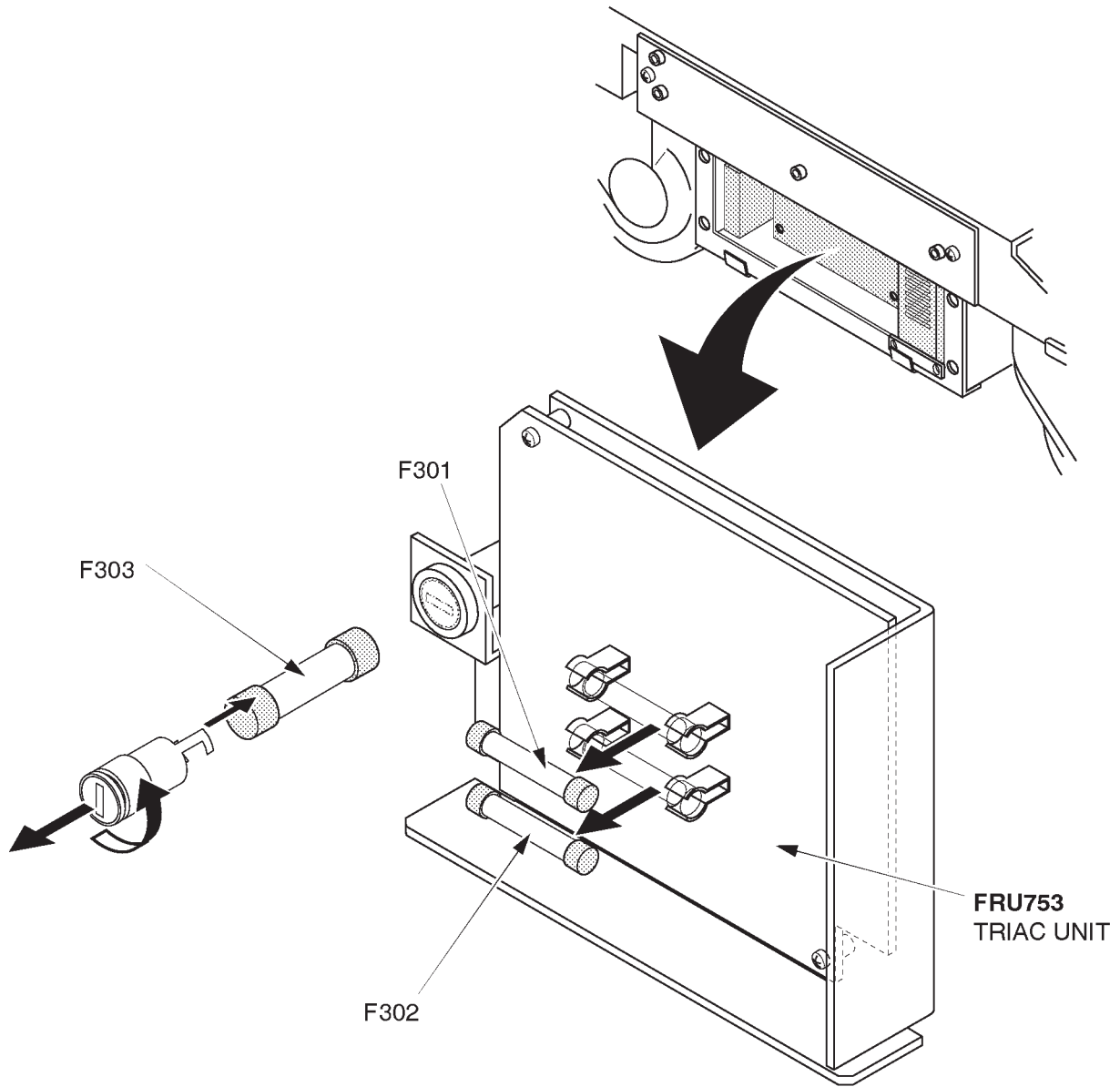

FUSES ON TRIAC UNIT REMOVAL
ILLUSTRATION 6-139



This page is left blank intentionally.

6-4 SYSTEM SOFTWARE INSTALLATION



Software MO (Magneto Optical) disk is not available in Europe. Please replace the hard disk for European systems instead of installing system software.

GEMS-AM recommends replacement of the HDD assy with the system software installed. Refer to the spare parts section of the service manual to identify the correct HDD assy with the correct version of software loaded.

6-4-1 Introduction

This section describes the procedures for installing the system software into the hard disk on LOGIQ™ 400.

Note

You can upgrade the version of LOGIQ™ 400 system software up using the Software Version Up function of LOGIQ™ 400 Service Software. Refer to LOGIQ™ 400 Proprietary Manual, 2127662.

Note

If you upgrade the system version, it is not necessary to backup the user data before installing new software. Because the user data remains unchanged after upgrading the system. If you install the system software a damaged hard disk, it is impossible to backup the user data before installation. Therefore, it is recommended to backup the user data periodically.

Tool Required

- Standard service tool
- Laptop PC with terminal emulation
- RS232C serial interface cable (cross type)
- System software MO disk
- Backup user data (MO disk)

Note

Refer to the following example or the pin assignment of Service port described in Chapter 3 and use the appropriate interface cable.

In the case of 9-pin to 25-pin interface cable:

Service Port of LOGIQ™ 400 :			Serial Port of Your PC :		
<u>Pin No.</u>	<u>Signal</u>		<u>Pin No.</u>	<u>Signal</u>	
2	TXD	-----	2	RXD	
3	RXD	-----	3	TXD	
4	RTS	-----	8	CTS	
5	CTS	-----	7	RTS	
7	GND	-----	5	GND	

6-4-2 Preparing before Installation

1. Turn the system power OFF.
2. Unplug the system. Follow the OSHA Lockout/Tagout Requirements (29 CFR 1910.147, Direction 46-015902).
3. Replace the hard disk with new one if necessary. Refer to 6-2-74 on page 6-189 for the replacement procedure of hard disk.
4. Connect the RS232C cable with the serial port of the Laptop PC. Refer to ILLUSTRATION 6-140.
5. Connect the connector of another side with the Service port located at the rear side of the LOGIQ™ 400 as shown in ILLUSTRATION 6-140.

Note

You may have to disconnect the insite connection.

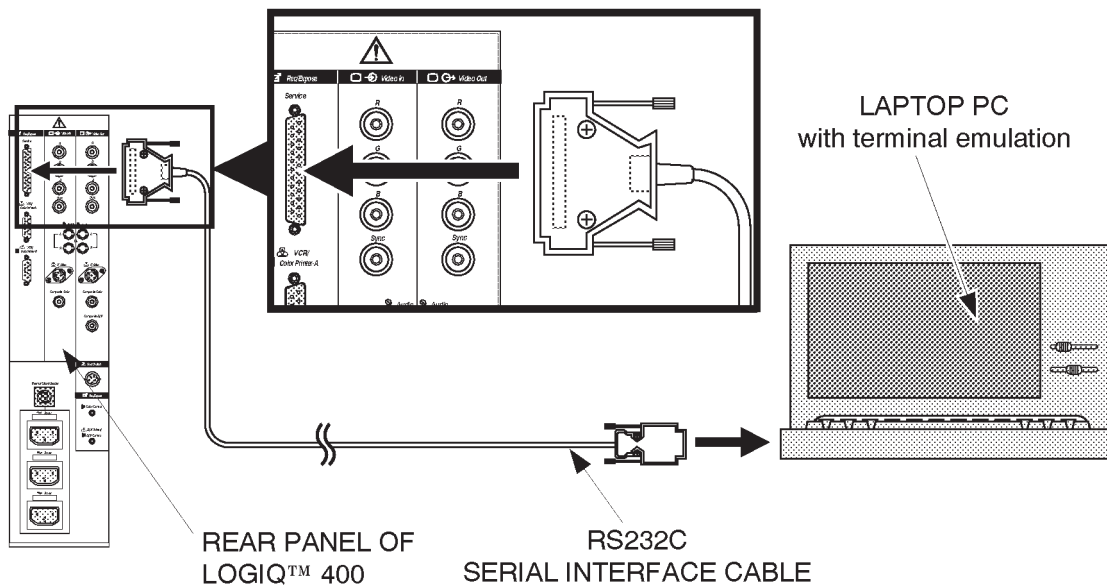

CHARACTER TERMINAL CONNECTION
ILLUSTRATION 6-140

6. Plug the system into a dedicated power receptacle.
7. Plug the Laptop PC into a wall outlet.

6-4-2 Preparing before Installation (continued)

8. Power the Laptop PC ON.
9. Start the terminal emulation software.
10. Make sure that the communication parameters are set as follows:

Baud Rate	:	9600 bps
Data Bits	:	8 bits
Stop Bit(s)	:	1 bit
Parity	:	None
Flow Control	:	None
Connector	:	COM1

6-4-3 Initializing Hard Disk

**Do not initialize the hard disk when upgrading the system software version up.
Initialize the hard disk before installing the system software only when the hard disk has been replaced with new one**

1. Turn the main power switch of the LOGIQ™ 400 system ON. The system does not perform the normal power up sequence and the message is indicated on the display of the Laptop PC as follows:

```
***VENUS RESET/START***  
***SCSI Device Mount Fail Device:HDD0 Error Code 20166  
ERROR CODE 200A  
VTSH>
```

MESSAGE ON PC DISPLAY
ILLUSTRATION 6-141

6-4-3 Initializing Hard Disk

2. Type the following command and press the return key.

```
VTSH>mediainit_0.0_PHILE_240000000_20_10000_4000
```

Note

For the console with software version 3.40 or later, use the following command:

```
VTSH>mediainit_0.0_PHILE_540000000_20_10000_4000
```

Note

The character “_” described in operating commands indicates the space.

After 20 minutes, the system completes the formatting of hard disk. The message “***Format Completed***” is displayed on the screen of Laptop PC.

3. Type the following command and press the return key. The hard disk become valid by entering this command.

```
VTSH>mount_0.0
```

6-4-4 Installing Software

1. Insert the appropriate system software MO disk into the MO disk drive of LOGIQ™ 400.
2. Type the following command and press the return key. The system will start writing software in the hard disk.

```
VTSH>cp_-r_2.0/*_0.0/
```

3. Turn the main switch of the system OFF after completing to write the software into the hard disk.
4. Turn the Laptop PC power OFF.
5. Disconnect the interface cable from the system.

6-4-5 Final Procedures

1. Turn the system power ON.
2. Check that the version number of the system software is correct, which is displayed on the CRT monitor screen during the power up sequence.
3. Set up the system preset parameters without regard to current settings. For set-up procedures, refer to LOGIQ™ 400 Proprietary Manual, 2127662.
 - 3-1 Set the Country/Zone properly. It takes approximately 40 minutes to complete this step.
 - 3-2. Set other three parameters, Video Signal, Power Frequency and Modem Kind.
 - 3-3. Reset the system using System Reset function of the Service Menu. Refer to LOGIQ™ 400 Proprietary Manual, 2127662.
4. Perform functional checks to verify that the system is functioning properly. Refer to Chapter 4, FUNCTIONAL CHECKS, in this manual.
5. Load the back-up user data into the system. For the procedure of loading back-up user data, refer to sub-section 4-3-3, Utility Menu in Chapter 4, FUNCTIONAL CHECKS.
6. This completes the installation of the LOGIQ™ 400 system software.

This page is left blank intentionally.

6-5 POWER SUPPLY REPLACEMENT

6-5-1 Introduction

This section describes the procedures for replacing the power supply unit of LOGIQ™ 400.

6-5-2 Replacement Procedures



PERSONAL INJURY HAZARD! POWER SUPPLY UNIT WEIGHS APPROXIMATELY 32 KILOGRAMS (71 POUNDS). PAY ATTENTION NOT TO BE INJURED. AT LEAST THREE PEOPLE SHOULD REPLACE THE POWER SUPPLY IN COOPERATION.

READ and UNDERSTAND these instructions thoroughly before proceeding with the replacement. Perform each step in sequence and check it off when completed. If a problem occurs after completion, go back through the procedure and check for implementation errors before contacting your Ultrasound Region Engineer.



Possible operational damage. Failure to strictly follow ESD (Electrostatic Discharge) precautions during this upgrade may cause constant or intermittent operational abnormalities. Strictly follow all precautions.

Check each step as it is completed.

Parts Required

To replace the 115V Power Supply Unit with new one, one of the followings is required:

FRU	PART NAME	QTY	PART #	REMARKS
711	115V Power Supply Unit	1	2126982	
757	115V Power Supply Unit2	1	2144481	
772	115V Power Supply Unit3	1	2212638	

To replace the 220V Power Supply Unit with new one, one of the followings is required:

FRU	PART NAME	QTY	PART #	REMARKS
712	220V Power Supply Unit	1	2126981	
758	220V Power Supply Unit2	1	2144480	
773	220V Power Supply Unit3	1	2212637	

6-5-2 Replacement Procedures (continued)**Time Required**

Approximately 1 Hour

Tools Required

Standard field Service Tool kit

(A) Replacing PS Unit

1. Turn the system power OFF. Follow the OSHA Lockout/Tagout Requirements (29 CFR 1910.147, Direction 46-015902).
2. Remove the Side Cover Left. Refer to 6-2-31 on page 6-127.
3. Remove the Side Cover Right. Refer to 6-2-32 on page 6-128.
4. Remove the Rear Cover. Refer to 6-2-33 on page 6-129.
5. Unscrew two screws (① and ②) to remove the Connector Guard Metal. Refer to ILLUSTRATION 6-142.

**CONNECTOR GUARD METAL DISASSEMBLY**

ILLUSTRATION 6-142

6-5-2 Replacement Procedures (continued)

- 6. Disconnect eight connectors (① – ⑧) from the PS Unit. All connectors are located above the Power Inlet unit at rear of the PS Unit. Refer to ILLUSTRATION 6-143.

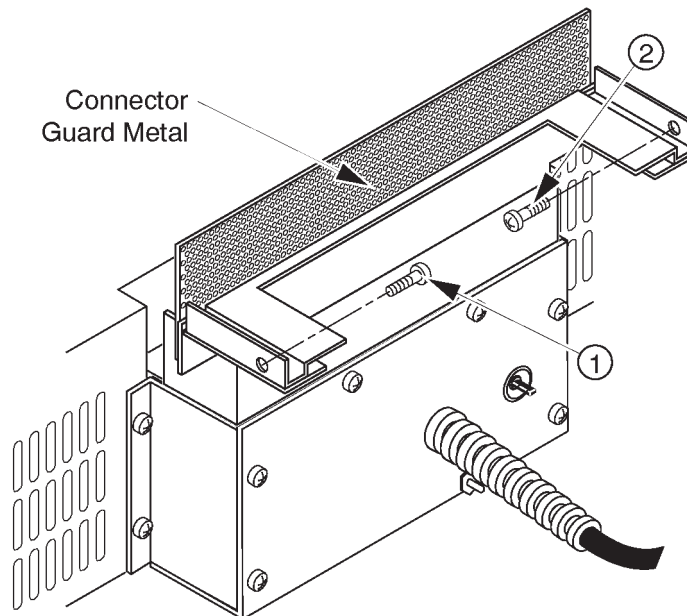
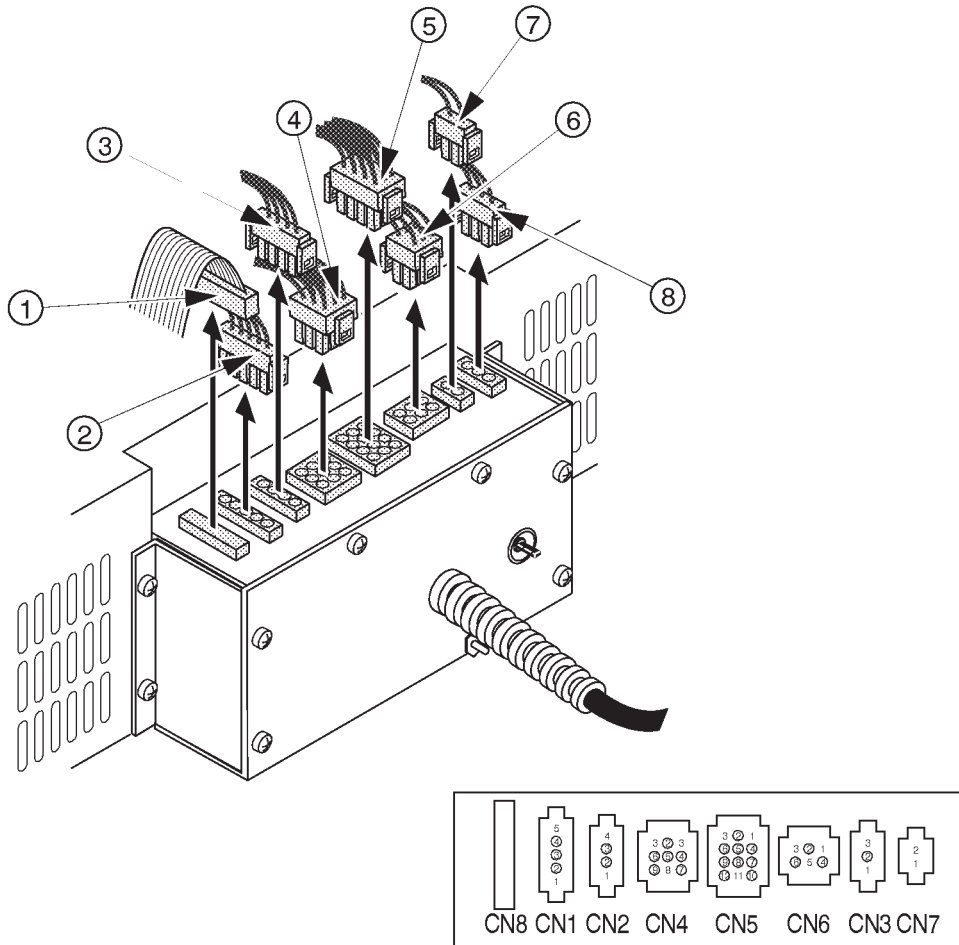

CONNECTORS ON PS UNIT
ILLUSTRATION 6-143

6-5-2 Replacement Procedures (continued)

7. Support the left side of PS Unit by one person.
- 8. Unscrew three Hexagonal bolts (① – ③) at the left side. Refer to ILLUSTRATION 6-144.
9. Support the right side of PS Unit by one person.
- 10. Unscrew three Hexagonal bolts (④ – ⑥) at the right side. Refer to ILLUSTRATION 6-144.

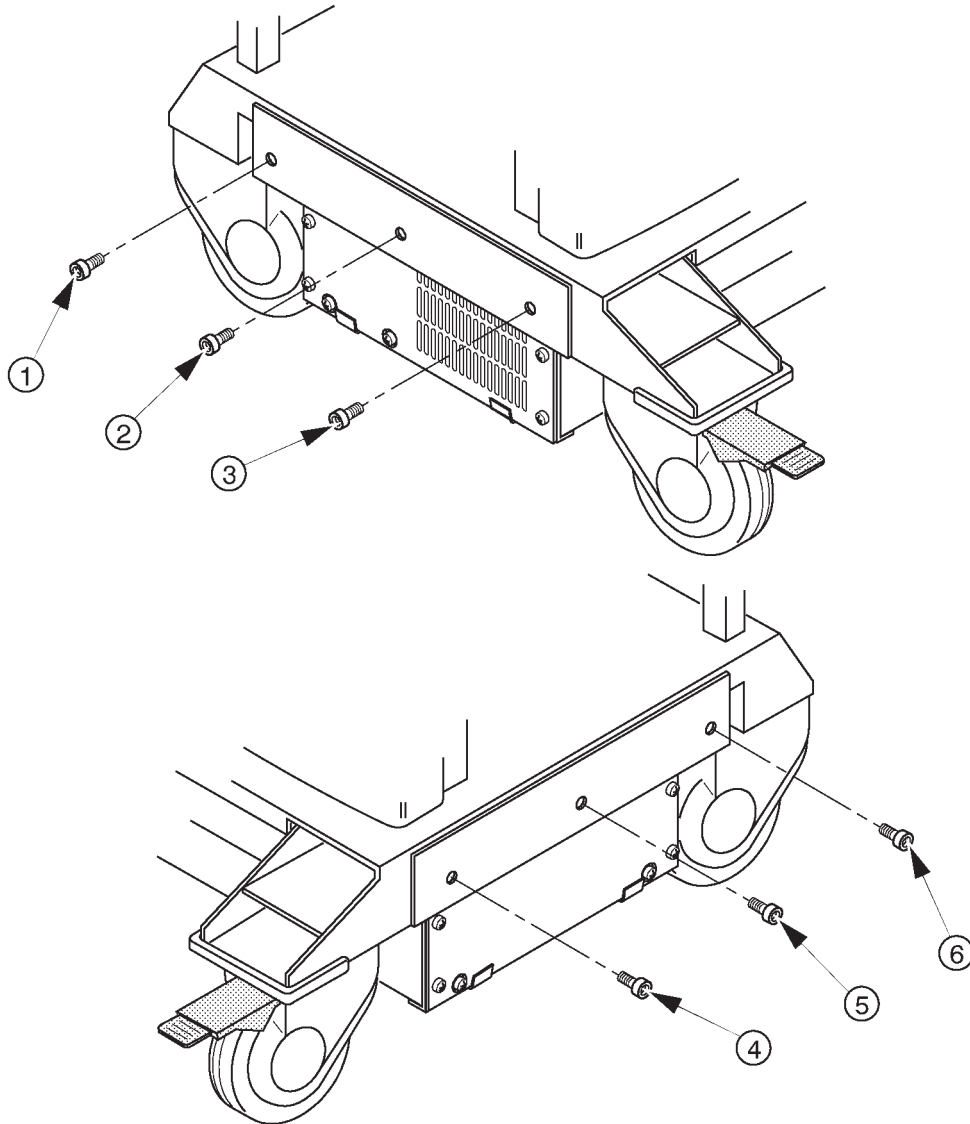

PS UNIT DISASSEMBLY
ILLUSTRATION 6-144



6-5-2 Replacement Procedures (continued)

11. Gently put down the PS Unit on the floor.
12. Install new PS Unit by the counter procedures.
- 13. Connect eight cables with the PS Unit. Refer to ILLUSTRATION 6-143 on page 6-259.

(B) Final Procedures

1. Plug in the system, set the circuit breaker to the ON position and turn the main power switch ON.
2. Perform all power supply checks. Refer to 4-4, POWER SUPPLY ADJUSTMENT in Chapter 4.
3. Perform the leakage current test. Refer to 7-3, ELECTRICAL SAFETY TESTS in Chapter 7.
4. Re-install the covers removed.
5. Perform functional checks to verify that the system is functioning properly. Refer to Chapter 4, FUNCTIONAL CHECKS, in this manual.
6. This completes the replacement of the Power Supply Unit.

This page is left blank intentionally.

6-6 REPLACING 2.5-INCH HDD ASSY WITH 3.5-INCH HDD ASSY

6-6-1 Introduction

This section provides the installation procedures of the 3.5-Inch HDD Assy using the Installation Kit for LOGIQ™ 400 console.

6-6-2 Time Required

1 hour

6-6-3 Parts Required

ITEM	PART NAME	QTY	PART #	REMARKS
1.	3.5-inch HDD Assy	2	—	Part number is different depending on the software version.
2.	HDD Change Kit	1	2160057	For 3.5-inch HDD Assy, including screws MOD and HDD to MOTHER HDD to MOTHER HDD to HDD LED Ass through CB46 This part is required only for LOGIQ™ 500
	HDD Holder2 Assy	1	2145973	
	CB24N Cable Assy	1	2145889	
	CB5N Cable Assy	1	2145890	
	CB45N Cable Assy	1	2145891	
	Tie Wrap	2	—	

Note

If the console includes the Quantum™ FireBall™ 1280S 3.5-inch HDD Assy, it is necessary to use the CB45N Cable Assy for the HDD LED Assy. Because the HDD LED Assy is not available on the console with this type of 3.5-inch HDD Assy.

6-6-4 Procedures

(A) Removing 2.5-inch HDD Assy, HDDB Assy and Cables

1. Turn the main power switch OFF.
2. Wait a while until the power off process is completed.
3. Set the circuit breaker located at the rear of Power Supply unit to OFF position (lower side).
4. Unplug the unit. Follow the OSHA Lockout/Tagout Requirements (29 CFR 1910.147, Direction 46-015902).
5. Remove the Keyboard Panel Assy. Refer to 6-2-49 on page 6-147.
6. Remove the Front Base Cover. Refer to 6-2-35 on page 6-131.
7. Remove the Side Cover Right. Refer to 6-2-32 on page 6-128.

6-6-4 Procedures (continued)

(A) Removing 2.5-inch HDD Assy, HDDB Assy and Cables (continued)

- 8. Unscrew four screws and remove the MODD Cover Metal.

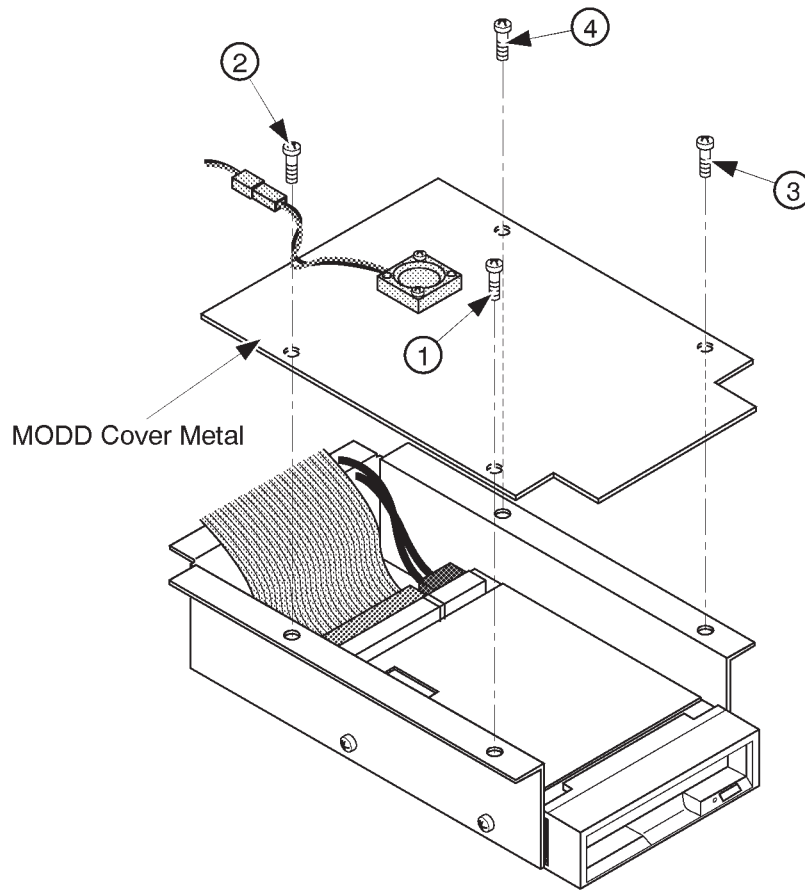

REMOVING MODD COVER METAL
ILLUSTRATION 6-145



6-6-4 Procedures (continued)

(A) Removing 2.5-inch HDD Assy, HDDB Assy and Cables (continued)

- 9. Disconnect the CB24M cable. Refer to ILLUSTRATION 6-146.

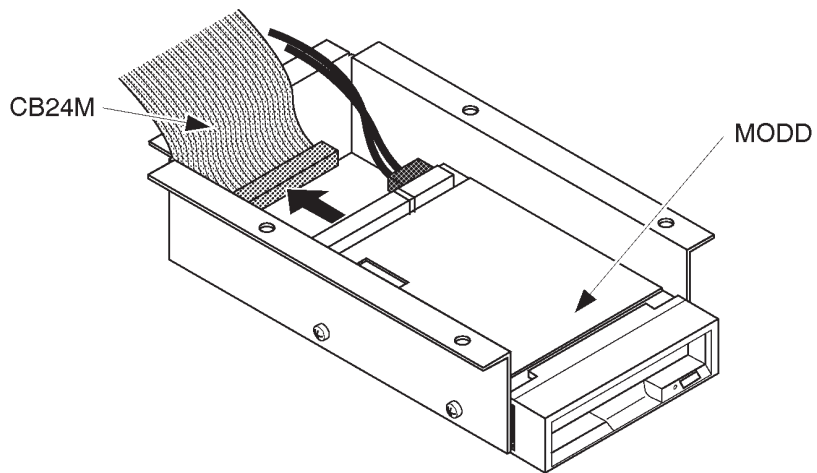

DISCONNECTING CB24 CABLE
ILLUSTRATION 6-146

- 10. Disconnect three cables, CB24M, CB5, and CB46, from the HDDB Assy. Refer to ILLUSTRATION 6-147.

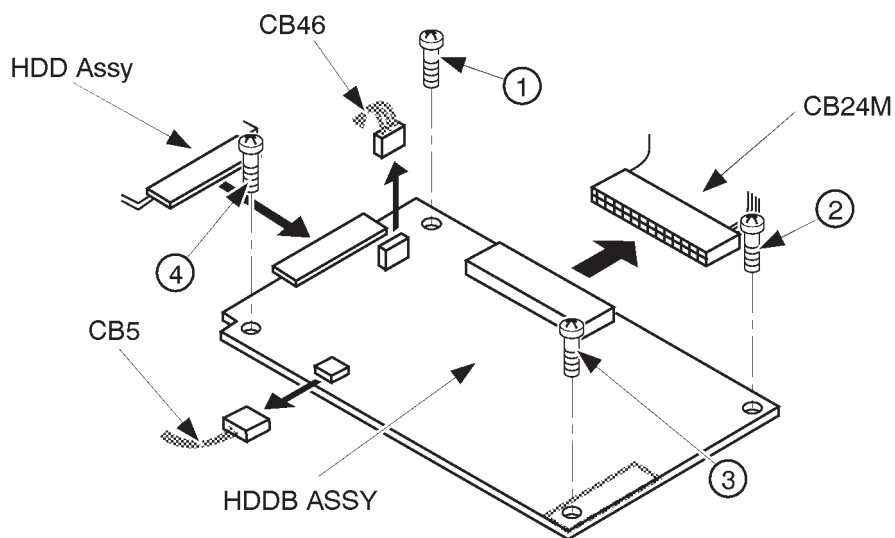

REMOVING HDDB ASSY
ILLUSTRATION 6-147

- 11. Unscrew four screws and remove the HDDB Assy. Refer to ILLUSTRATION 6-147.

6-6-4 Procedures (continued)

(A) Removing 2.5-inch HDD Assy, HDDB Assy and Cables (continued)

- 12. Unscrew two screws and remove the 2.5-inch HDD Assy with HDD Holder Assy. Refer to ILLUSTRATION 6-148.

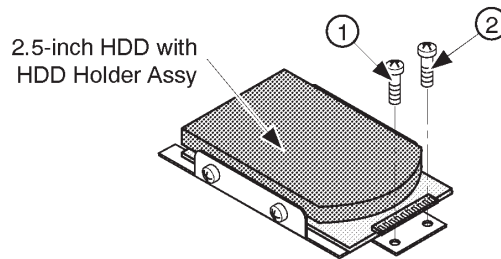

REMOVING 2.5-INCH HDD ASSY
ILLUSTRATION 6-148

- 13. Disconnect the CB24M cable from the Mother Assy and Rear1 Assy and the CB5 cable from the Mother Assy. Refer to ILLUSTRATION 6-149.

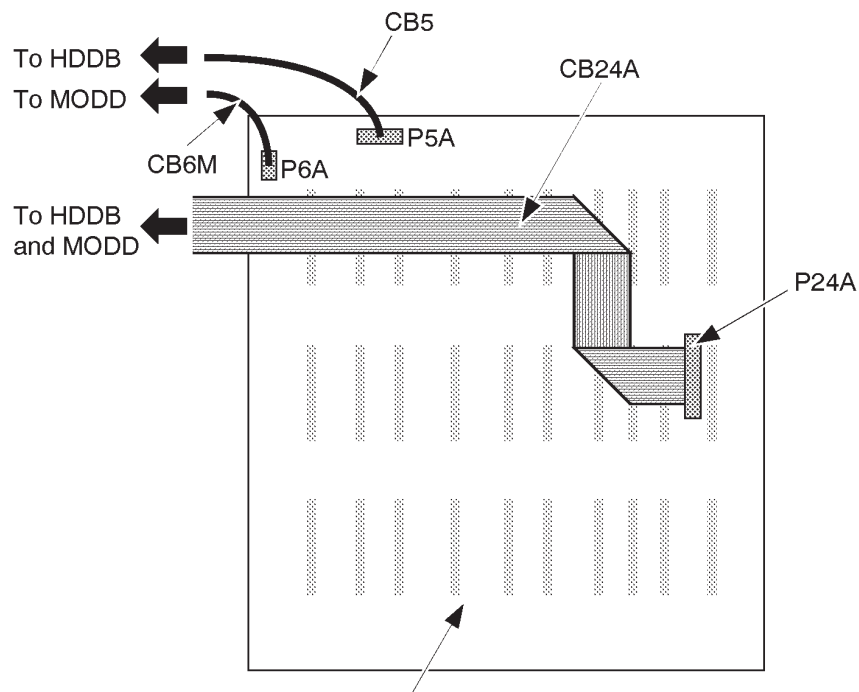

MOTHER BOARD
REMOVING CABLES
ILLUSTRATION 6-149

- 14. Remove the CB24M and CB5 cables.

6-6-4 Procedures (continued)

(B) Connecting Cables

- 15. Connect the CB24N Cable with the P24A connector on the Mother Assy. Refer to ILLUSTRATION 6-150.
- 16. Connect the CB5N Cable with the P5A connector on the Mother Assy. Refer to ILLUSTRATION 6-150.

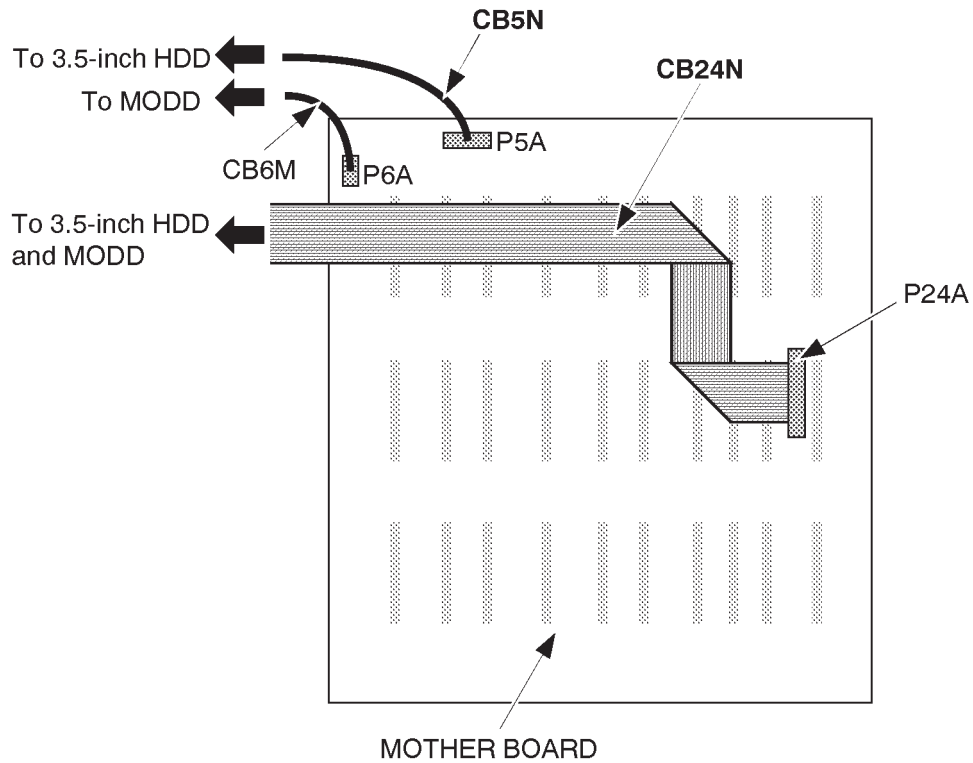

REMOVING CABLES
ILLUSTRATION 6-150

- 17. Pass another side of cables through the opening of Frame forward to the MODD and HDD.

6-6-4 Procedures (continued)

(C) Installing 3.5-Inch HDD Assy

- 18. Make sure that the four jumper switch are set as shown in ILLUSTRATION 6-151.
- 19. Make sure that the Terminator Module IC is not mounted on the 3.5-inch HDD Assy. Refer to ILLUSTRATION 6-151.

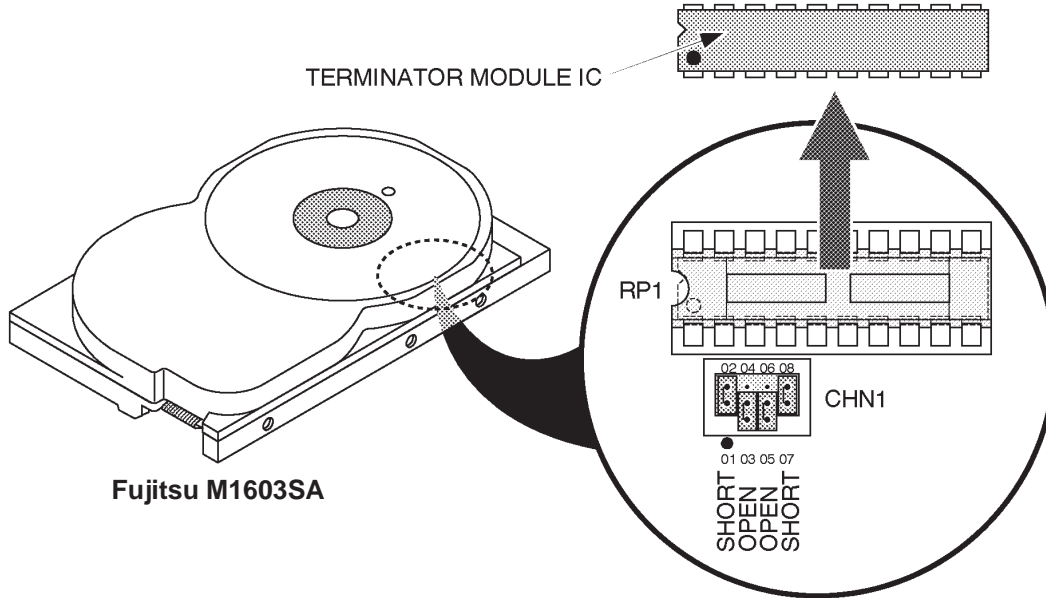

Fujitsu M1603SA

REMOVING CABLES
ILLUSTRATION 6-151

Note

The setting of jumper switches for the new 3.5-inch HDD Assy (Quantum™ Fireball™ 1280S) is different from the old one. Refer to ILLUSTRATION 6-152 to check and set the jumper switches properly.

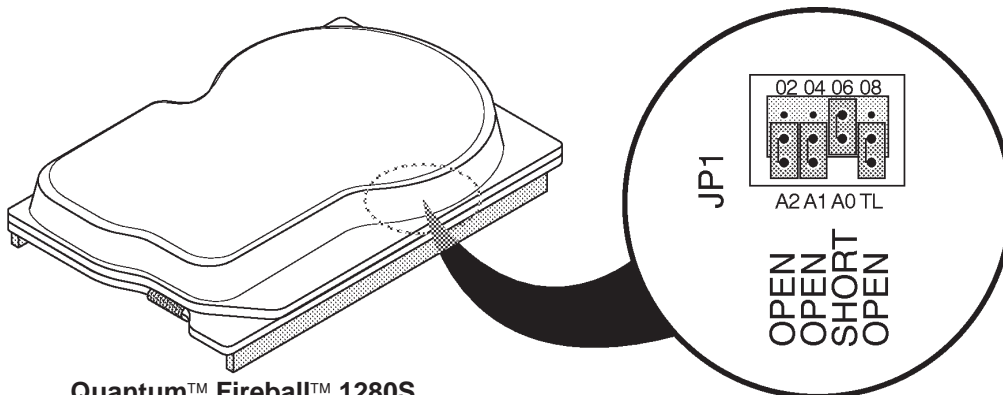

Quantum™ Fireball™ 1280S

BOTTOM VIEW OF 3.5-INCH HDD (b)
ILLUSTRATION 6-152

6-6-4 Procedures (continued)

(C) Installing 3.5-Inch HDD Assy

Note

The setting of jumper switches for the new 3.5-inch HDD Assy (Quantum™ Fireball™ EL) is different from the other one. Refer to ILLUSTRATION 6-152 to check and set the jumper switches properly.

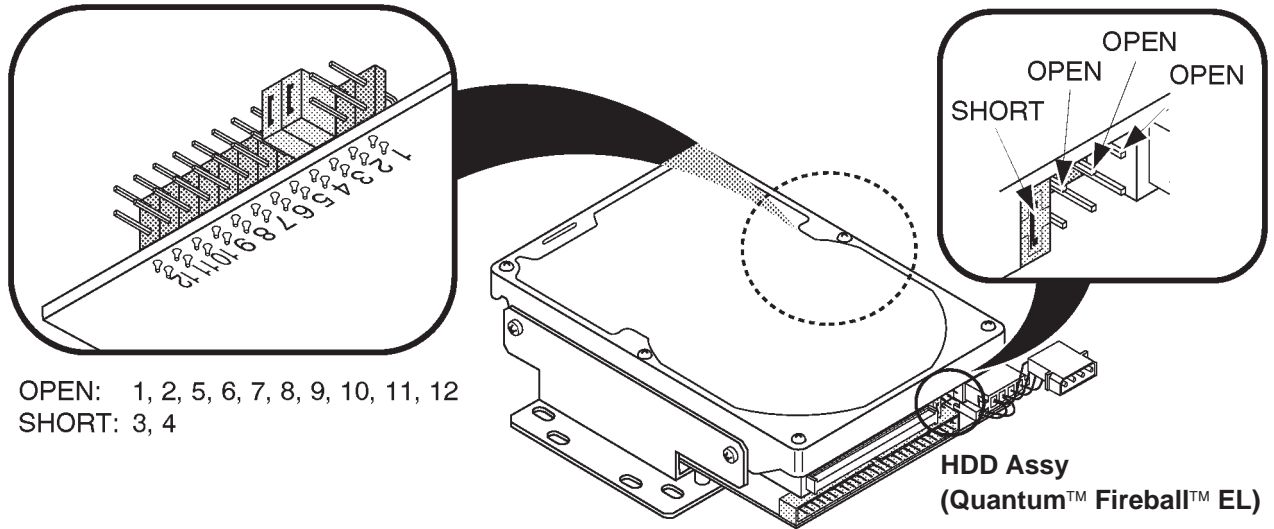

SETTING OF JUMPER SWITCHES OF HDD ASSY
ILLUSTRATION 6-153

6-6-4 Procedures (continued)

(C) Installing 3.5-Inch HDD Assy (continued)

- 20. Connect the CB45N cable with the 3.5-inch HDD Assy. Refer to ILLUSTRATION 6-154.
- 21. Connect another side of the CB45N cable to the CB46 cable.

Note

The CB45N and CB46 cables are not included in the LOGIQ™ 400CL. It is not necessary to install those cables to the LOGIQ™ 400CL console.

- 22. Set the 3.5-inch HDD Assy on the HDD Holder2 Assy. Refer to ILLUSTRATION 6-154.
- 23. Screw four screws supplied with the HDD Change Kit to install the 3.5-inch HDD Assy to the HDD Holder2 Assy. Refer to ILLUSTRATION 6-154.
-

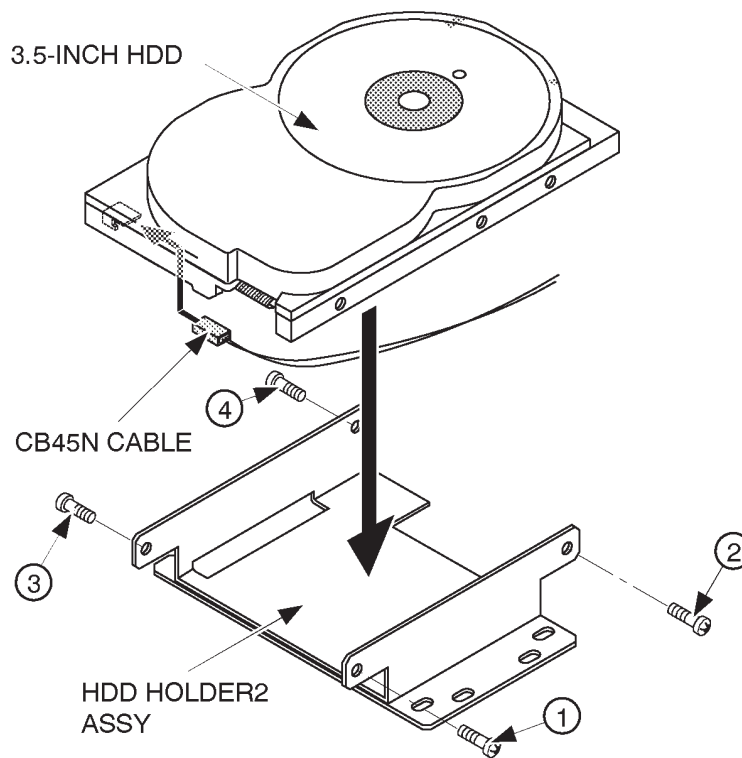

INSTALLING 3.5-INCH HDD ASSY ON HDD HOLDER2 ASSY
ILLUSTRATION 6-154

Note

The HDD LED Assy is not available on the console with the new type of 3.5-inch HDD Assy (Quantum™ FireBall™ 1280S). In this case, the CB45N cable is not used. Hold the CB46 cable onto the metal frame with an adhesive tape.

6-6-4 Procedures (continued)

(C) Installing 3.5-Inch HDD Assy (continued)

24. Screw two screws supplied with the HDD Change Kit to install the 3.5-inch HDD Assy with HDD Holder2 Assy on the console. Refer to ILLUSTRATION 6-155.
25. Connect the CB24N and CB5N cables with the 3.5-inch HDD Assy as shown in ILLUSTRATION 6-155.

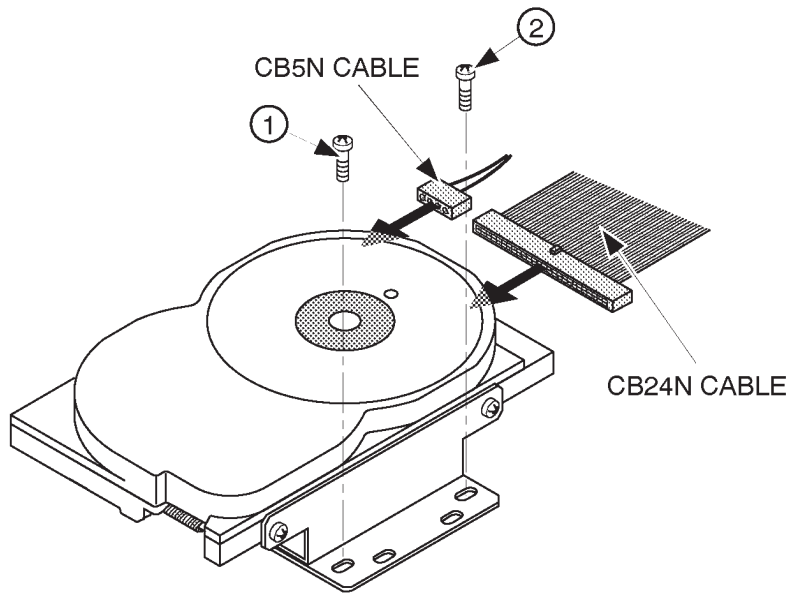

INSTALLING 3.5-INCH HDD ASSY ON CONSOLE
ILLUSTRATION 6-155

6-6-4 Procedures (continued)

(C) Installing 3.5-Inch HDD Assy (continued)

Note

Before connecting the CB24N cable, fold the CB24N cable suitably. Refer to ILLUSTRATION 6-156.

Note

The folding method of CB24N cable is different depending on the type of MODD (U0052ZA or 2187012). Before connecting the CB24N cable, fold the CB24N cable suitably. Refer to ILLUSTRATION 6-156.

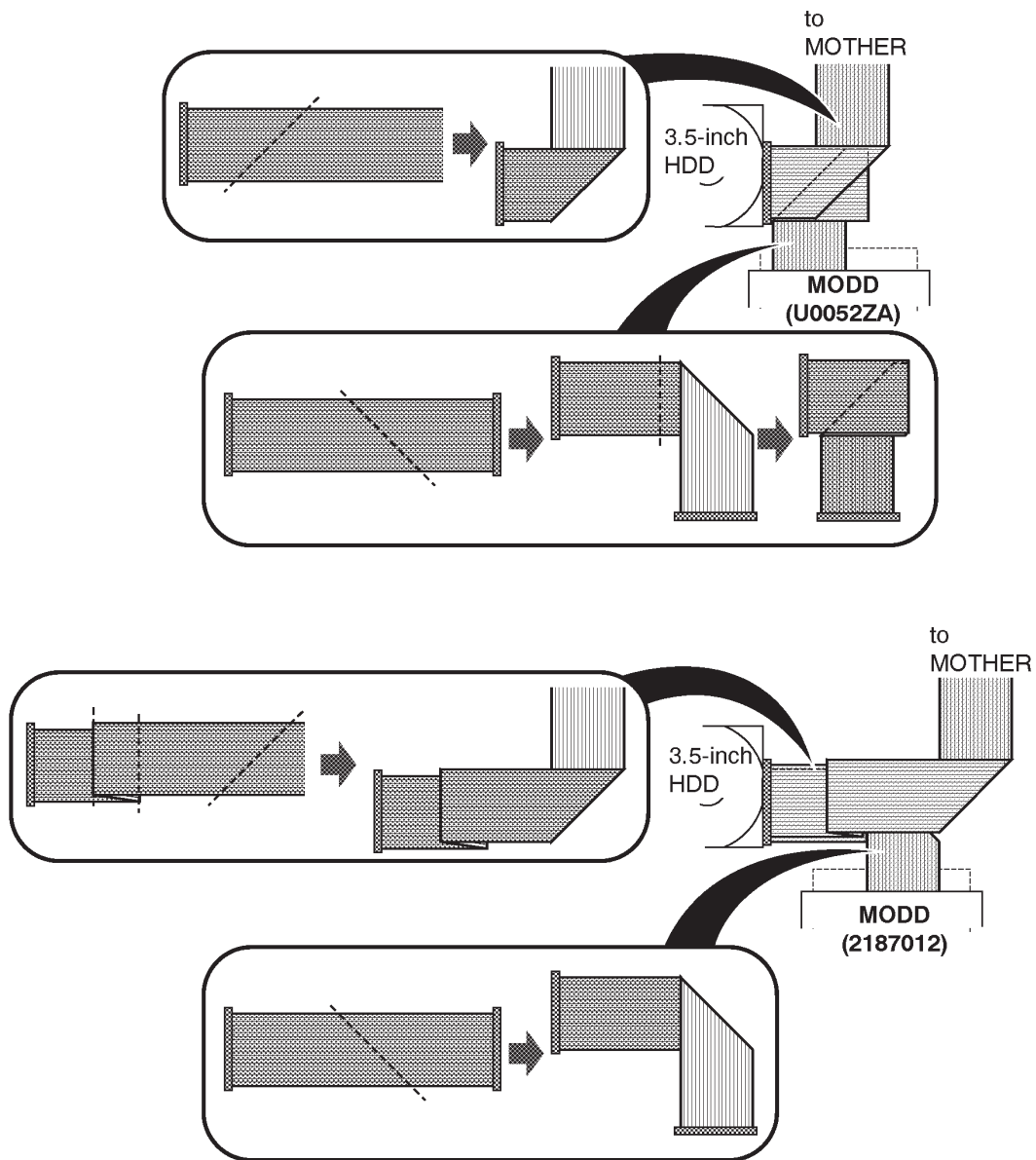

INSTALLING 3.5-INCH HDD ASSY ON CONSOLE

ILLUSTRATION 6-156

6-6-4 Procedures (continued)

(C) Installing 3.5-Inch HDD Assy (continued)

- 26. Change the settings of jumper switches on the MODD Assy as shown in ILLUSTRATION 6-157.

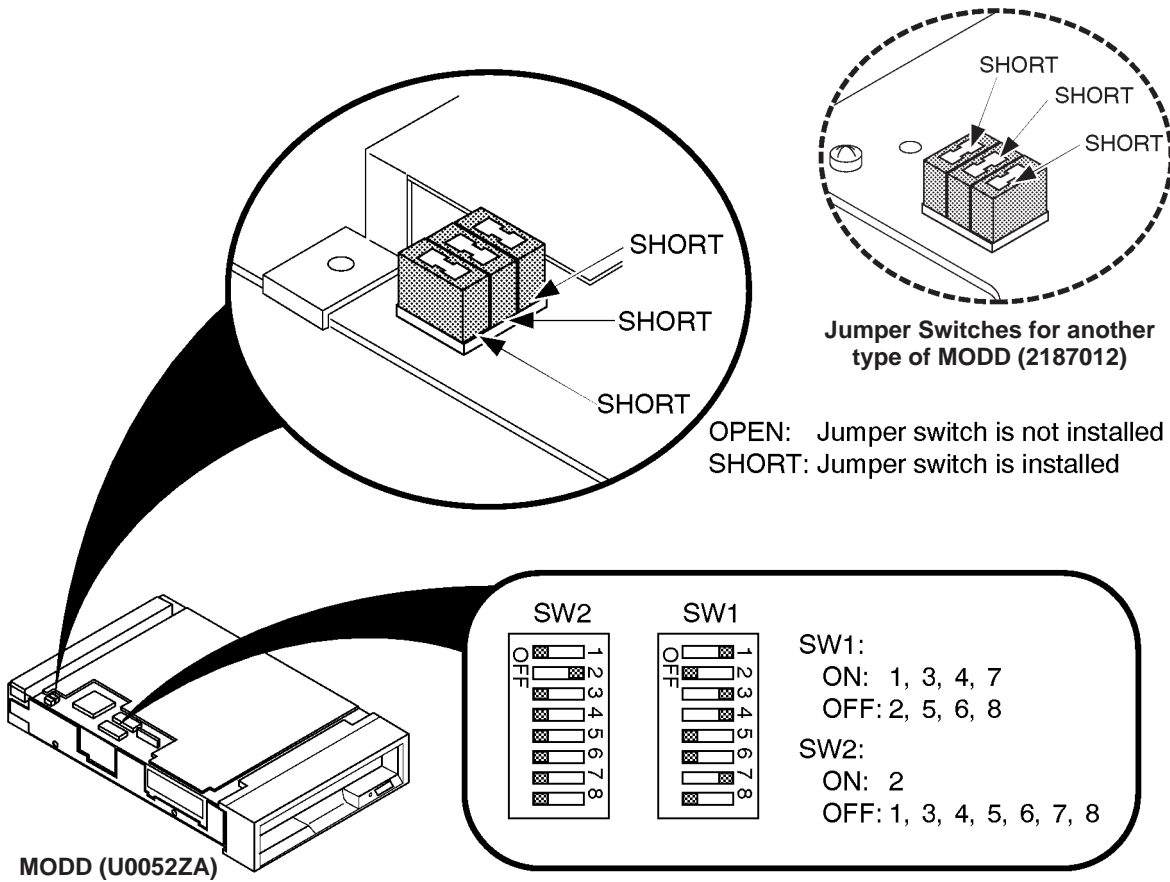

MODD JUMPER SWITCH SETTINGS
ILLUSTRATION 6-157

6-6-4 Procedures (continued)

(C) Installing 3.5-Inch HDD Assy (continued)

Note

When the MODD installed is the type of "2187012-2", set the DIP switches and the jumper switches as shown in ILLUSTRATION 6-103.

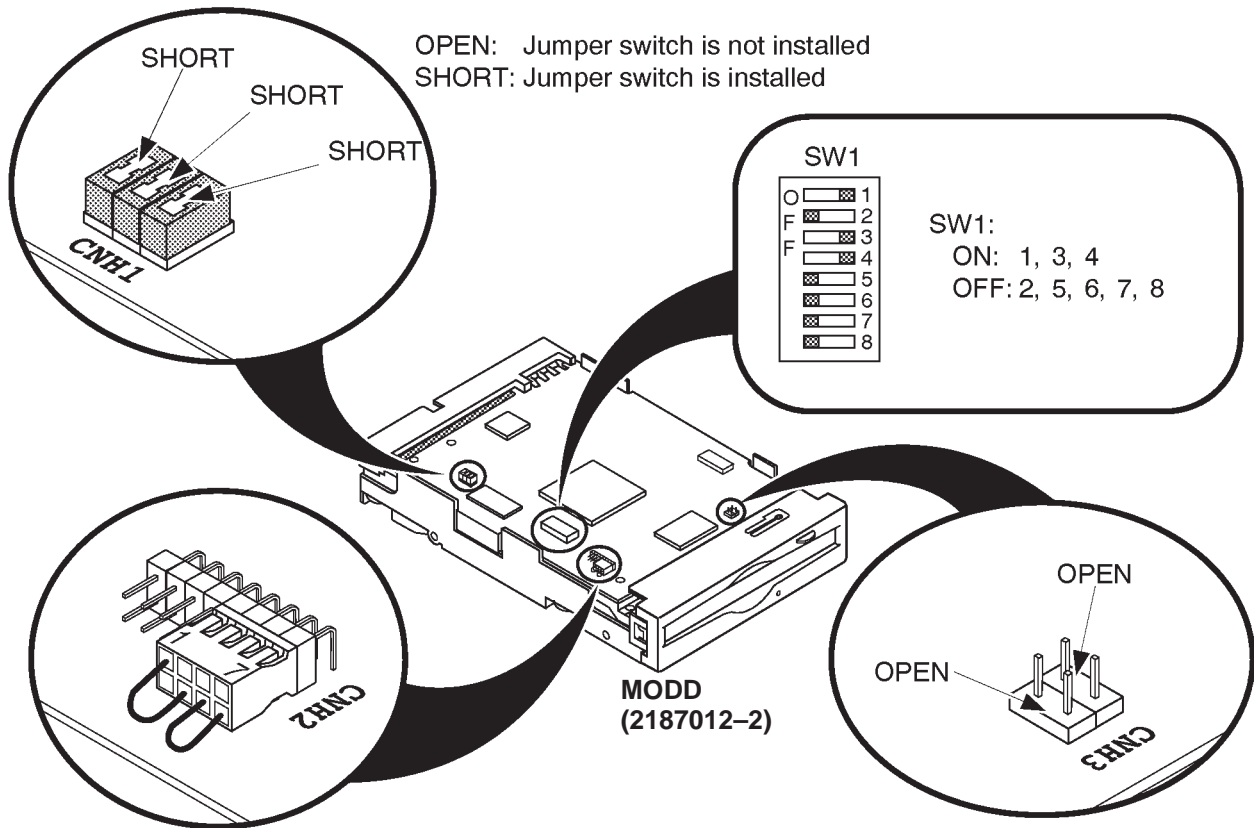

SETTINGS OF SWITCHES ON MODD
ILLUSTRATION 6-158

27. Connect the CB24N with the MODD Assy. Refer to ILLUSTRATION 6-146 on page 6-265.
28. Screw four screws and install the MODD Cover Metal. Refer to ILLUSTRATION 6-145 on page 6-264.
29. Re-install the Side Cover Right. Refer to 6-2-32 on page 6-128.
30. Re-install the Front Base Cover. Refer to 6-2-35 on page 6-131.
31. Re-install the Keyboard Panel Assy. Refer to 6-2-49 on page 6-147.
32. This completes the Replacing 2.5-inch HDD Assy with 3.5-inch HDD Assy.

This page is left blank intentionally.

6-7 REPLACING LV2 UNIT WITH LV3 UNIT

6-7-1 Introduction

This section provides the procedures for replacing the LV2 Unit with the LV3 Unit on LOGIQ™ 400 console.

6-7-2 Time Required

Approximately 1 hour

6-7-3 Parts Required

ITEM	PART NAME	QTY	PART #	REMARKS
1.	LV3 UNIT	1	2211491	including CN31 CABLE (for LV3 UNIT) and PN LABEL

6-7-4 Procedures

(A) Removing LV2 Unit

1. Turn the LOGIQ™ 400 system power OFF.
2. Turn the circuit breaker located at the rear side of the Power Supply to the OFF position (lower side).
3. Unplug the unit. Follow the OSHA Lockout/Tagout Requirements (29 CFR 1910.147. Direction 46-015902).
4. Remove two screw caps (located at the place of the ③ and ④ screws).
- 5. Unscrew four screws (① – ④). Refer to ILLUSTRATION 6-159 on page 6-277.
6. Remove the Side Cover Left.
- 7. Unscrew three screws (⑤ – ⑦). Refer to ILLUSTRATION 6-159 on page 6-277.
8. Remove the Front Base Cover.
- 9. Unscrew five screws (⑧ – ⑫). Refer to ILLUSTRATION 6-159 on page 6-277.
10. Remove the Side Cover Right.

6-7-4 Procedures (continued)

(A) Removing LV2 Unit (continued)

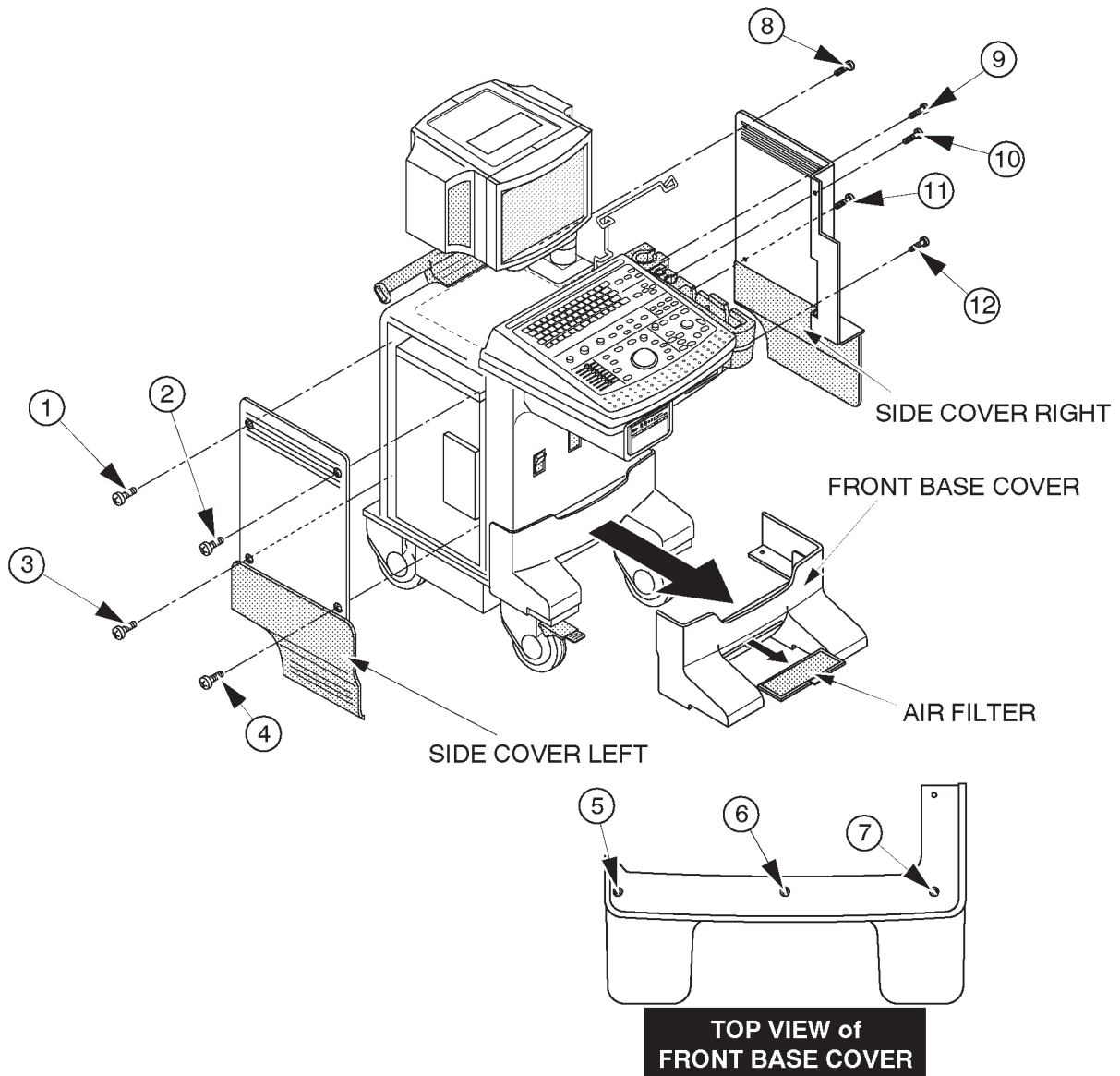

REMOVING COVERS
ILLUSTRATION 6-159

6-7-4 Procedures (continued)

(A) Removing LV2 Unit (continued)

- 11. Unscrew four screws (① – ④). Refer to ILLUSTRATION 6-160.
- 12. Remove the Left PS Cover .

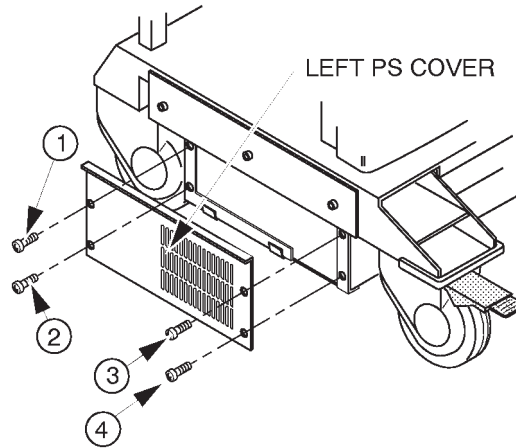

REMOVING LEFT PS COVER
ILLUSTRATION 6-160

- 13. Unscrew two screws (① and ②). Refer to ILLUSTRATION 6-161.
- 14. Pull the LV2 Unit outwards. Refer to ILLUSTRATION 6-161.

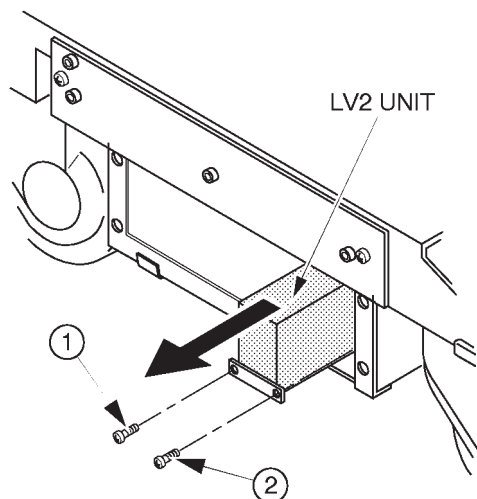

REMOVING LV2 UNIT
ILLUSTRATION 6-161

6-7-4 Procedures (continued)

(A) Removing LV2 Unit (continued)

- 15. Unscrew fourteen (14) screws (① – ⑭) to remove the wires. Refer to ILLUSTRATION 6-162.
- 16. Disconnect five connectors (⑮–⑰). Refer to ILLUSTRATION 6-162.
- 17. Pull the LV2 Unit Outwards.

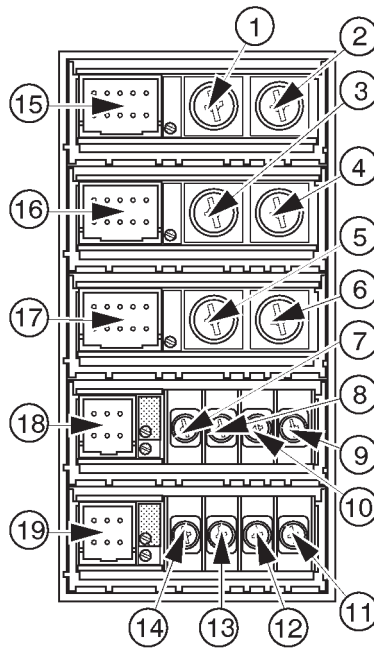

FRONT VIEW OF LV2 UNIT
ILLUSTRATION 6-162

6-7-4 Procedures (continued)

(A) Removing LV2 Unit (continued)

18. Disconnect one connector (①) from the rear of LV2 Unit. Refer to ILLUSTRATION 6-163.
19. Unscrew three screws (② – ④) to remove the three wires. Refer to ILLUSTRATION 6-163.
20. Remove the LV2 Unit.

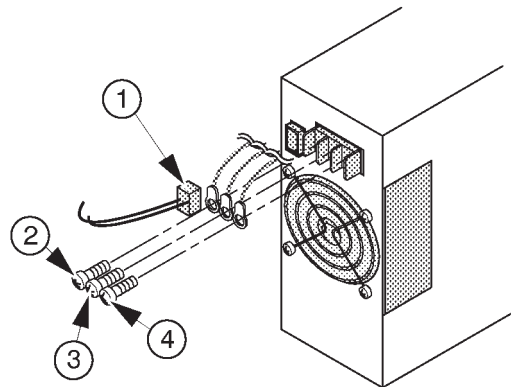

REAR VIEW OF LV2 UNIT
ILLUSTRATION 6-163

21. Disconnect the CN31 cable from the TRIAC Unit. Refer to ILLUSTRATION 6-164.

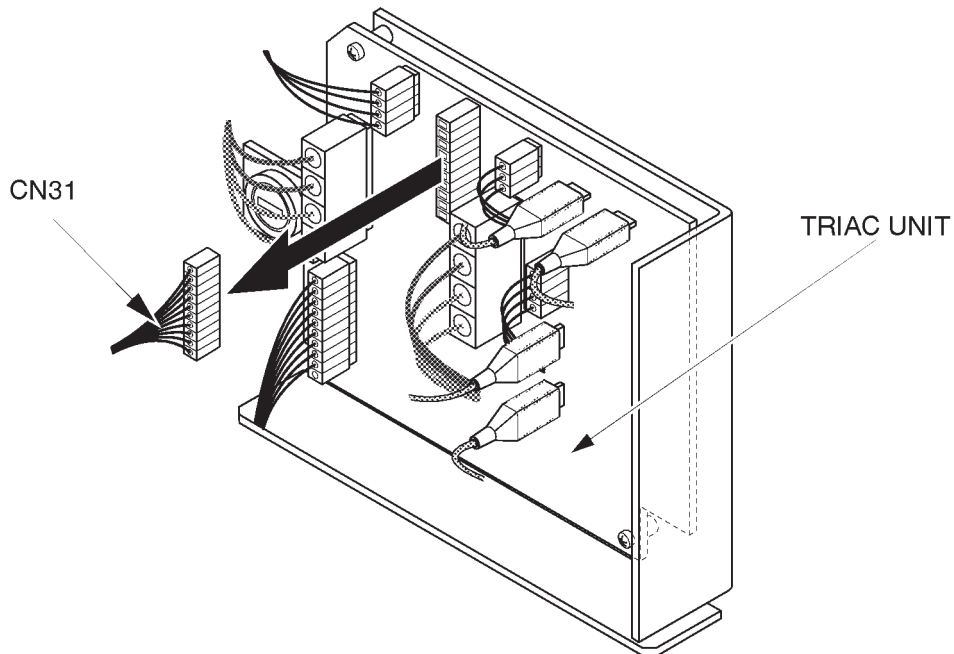

DISCONNECTING CN31 CABLE
ILLUSTRATION 6-164

6-7-4 Procedures (continued)

(B) Installing LV3 Unit

1. Screw two screws (① and ②) to fix the two wires [LINE(L) and NEUTRAL(N)]. Refer to ILLUSTRATION 6-165.

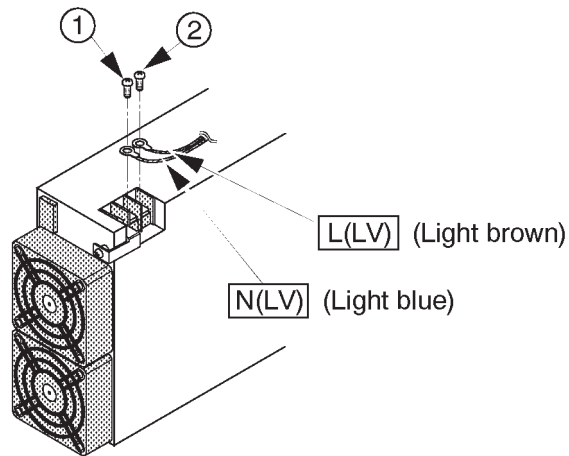

REAR VIEW OF LV3 UNIT
ILLUSTRATION 6-165

2. Insert the LV3 Unit as shown in ILLUSTRATION 6-166.
3. Screw two screws (① and ②) to install the LV3 Unit. Refer to ILLUSTRATION 6-166.

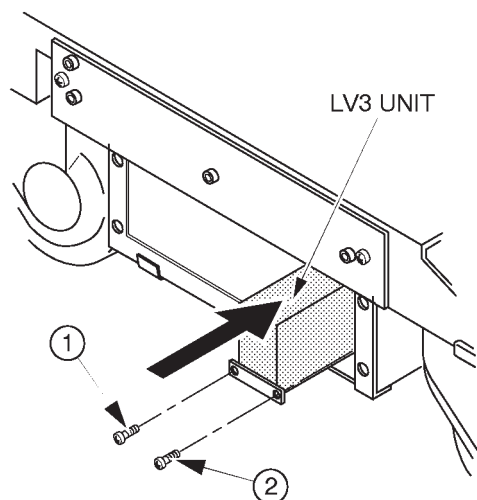

INSTALLING LV3 UNIT
ILLUSTRATION 6-166

6-7-4 Procedures (continued)

(B) Installing LV3 Unit (continued)

4. Unscrew four (4) screws (① – ④). Refer to ILLUSTRATION 6-167.
5. Remove the Right PS Cover. Refer to ILLUSTRATION 6-167.
6. Unscrew three (3) screws (⑤ – ⑦). Refer to ILLUSTRATION 6-167.
7. Disconnect one connector (⑧). Refer to ILLUSTRATION 6-167.
8. Pull the HV Unit out.

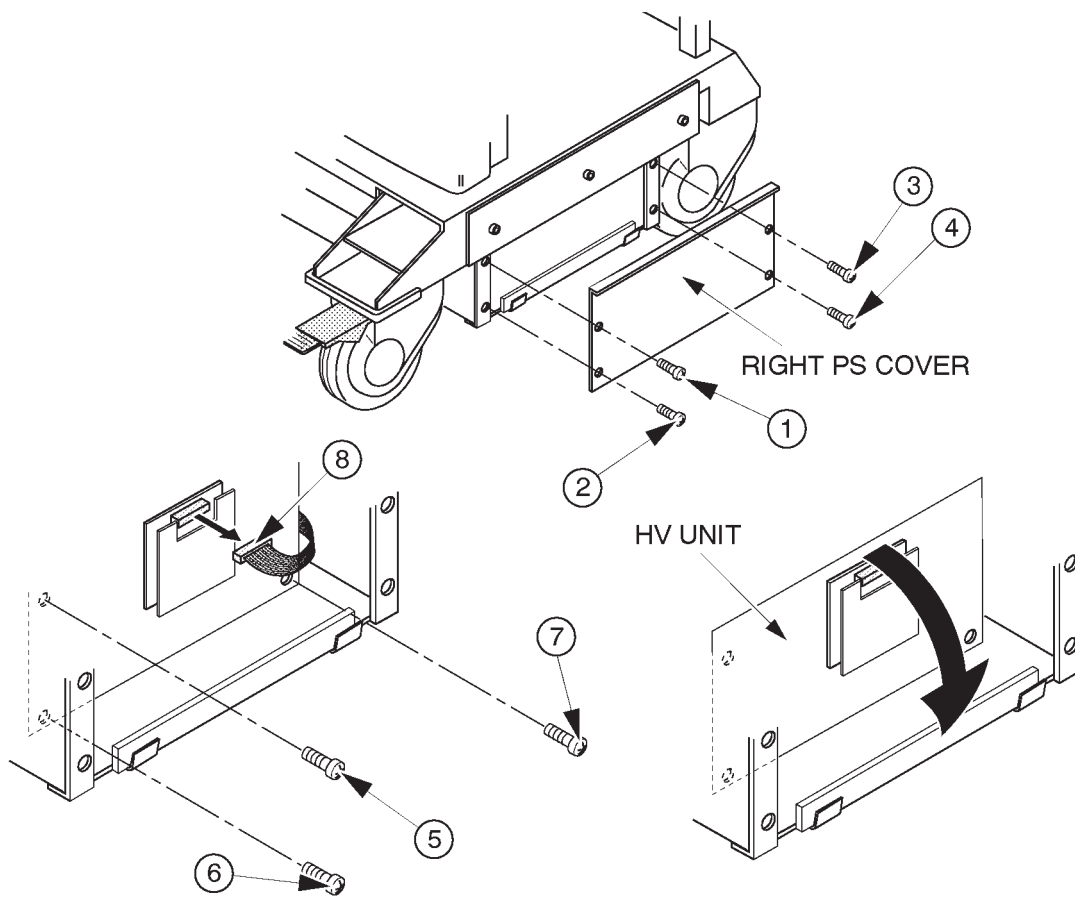

RIGHT SIDE VIEW OF POWER SUPPLY
ILLUSTRATION 6-167

Note

It is not necessary to remove the HV Unit completely. Pull the HV Unit out to get the openings for accessing the rear of the LV3 Unit by a hand.

6-7-4 Procedures (continued)**(B) Installing LV3 Unit** (continued)

9. Connect one connector (①) as shown in ILLUSTRATION 6-168.

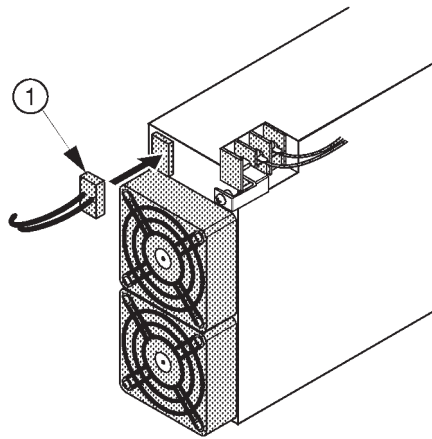

REAR VIEW OF LV3 UNIT (b)
ILLUSTRATION 6-168

10. Screw three (3) screws (⑤ – ⑦) to install the HV Unit. Refer to ILLUSTRATION 6-167 on page 6-282.
11. Connect one connector (⑧). Refer to ILLUSTRATION 6-167 on page 6-282.
12. Screw four (4) screws (① – ④) to install the Right PS Cover. Refer to ILLUSTRATION 6-167 on page 6-282.

6-7-4 Procedures (continued)

(B) Installing LV3 Unit (continued)

- Screw fourteen (14) screws (1) – (14) to fix the wires to the appropriate terminals. Refer to ILLUSTRATION 6-169.

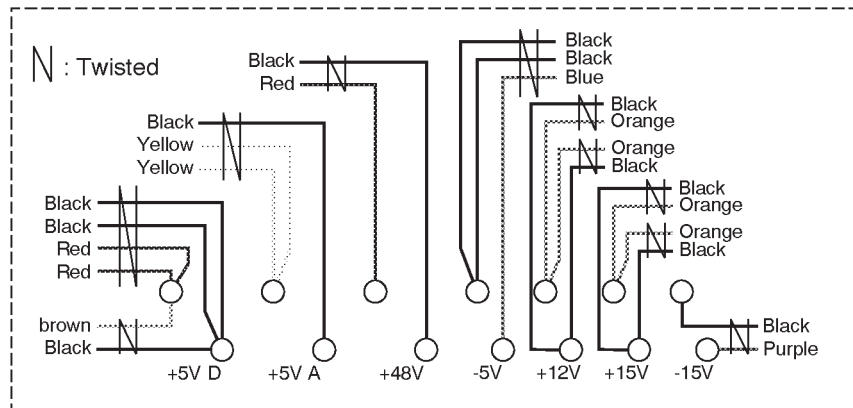
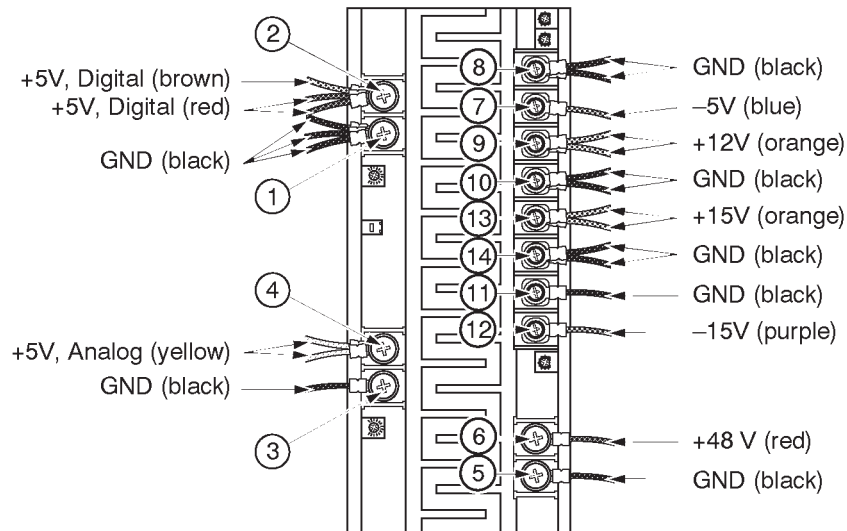

FIXING WIRES
ILLUSTRATION 6-169

6-7-4 Procedures (continued)

(B) Installing LV3 Unit (continued)

14. Connect the CN31 cable for LV3 Unit (supplied with the LV3 Unit) to the TRIAC Unit. Refer to ILLUSTRATION 6-170.
15. Connect another side of CN31 cable for LV3 Unit to the connector located at the front of the LV3 Unit as shown in ILLUSTRATION 6-170 .

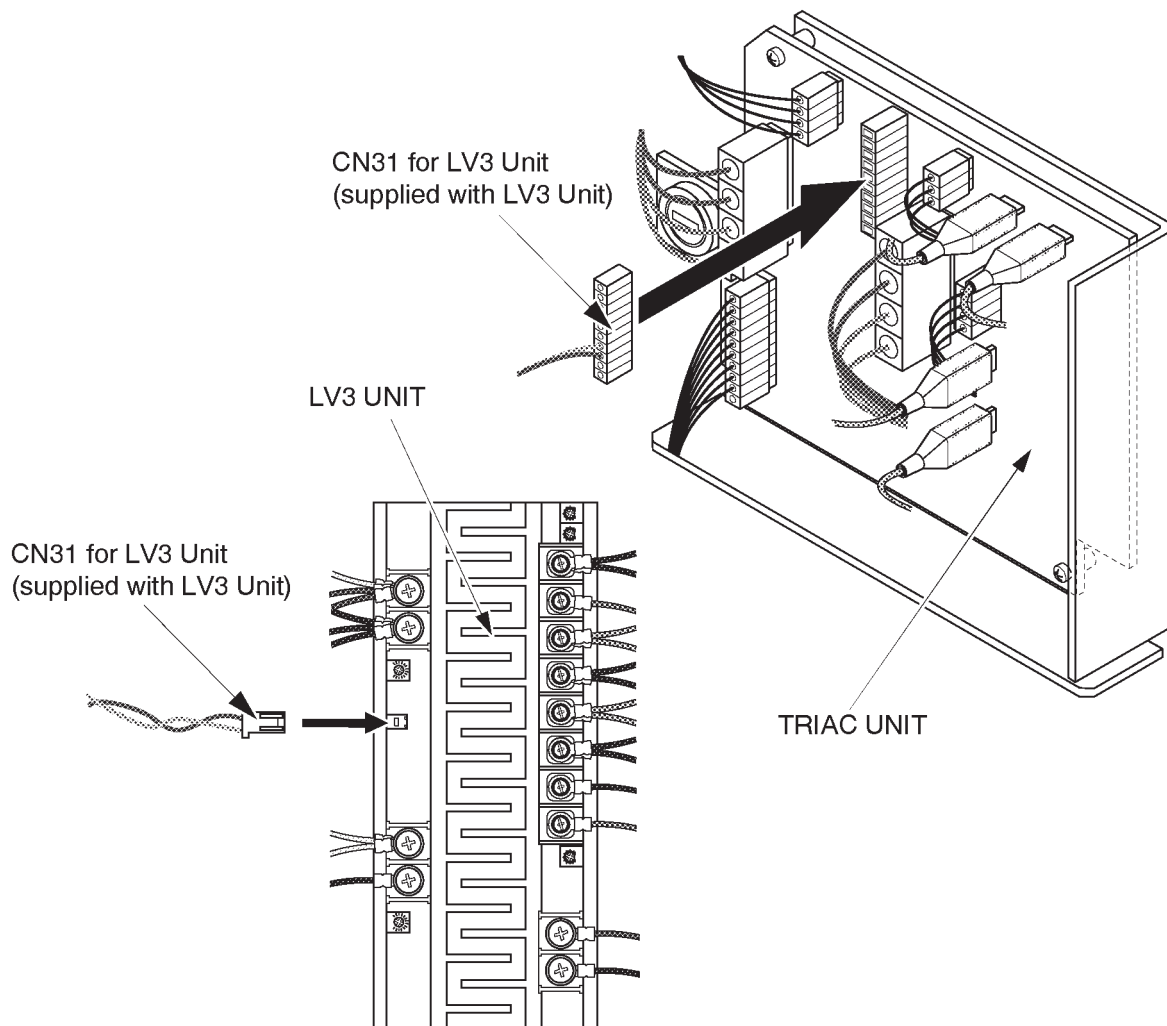

CONNECTING CN31 CABLE FOR LV3 UNIT
ILLUSTRATION 6-170

6-7-4 Procedures (continued)**(C) System Check-out**

1. Plug in the unit.
2. Turn the circuit breaker located at the rear side of the Power Supply to the ON position (upper side).
3. Turn the LOGIQ™ 400 system power ON.
4. Make sure that the power supplies are within each tolerance. Refer to the section 4-4 "POWER SUPPLY ADJUSTMENTS" in chapter 4. For the tolerances of the power supplies, refer to TABLE 4-3. For the measurement locations, refer to TABLE 4-4 and ILLUSTRATION 4-32 on page 4-43.
5. Adjust the power supplies to the appropriate voltage as necessary if they are out of tolerance.
6. Perform functional checks to verify that the system is functioning properly. Refer to Chapter 4, FUNCTIONAL CHECKS in the LOGIQ™ 400 Service Manual, 2127661.
7. Turn the LOGIQ™ 400 system power OFF.
8. Screw four screws (① – ④) to install the Left PS Cover. Refer to ILLUSTRATION 6-171.

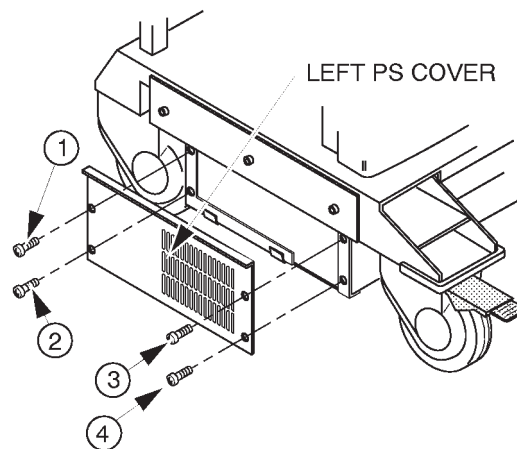

IRE-INSTALLING LEFT PS COVER
ILLUSTRATION 6-171

6-7-4 Procedures (continued)

(C) System Check-out (continued)

9. Attach the label (PN LABEL supplied with the LV3 Unit) indicating the part number of the Power Supply Assy over the old label located at the front side of the Power Supply Unit as shown in ILLUSTRATION 6-172.

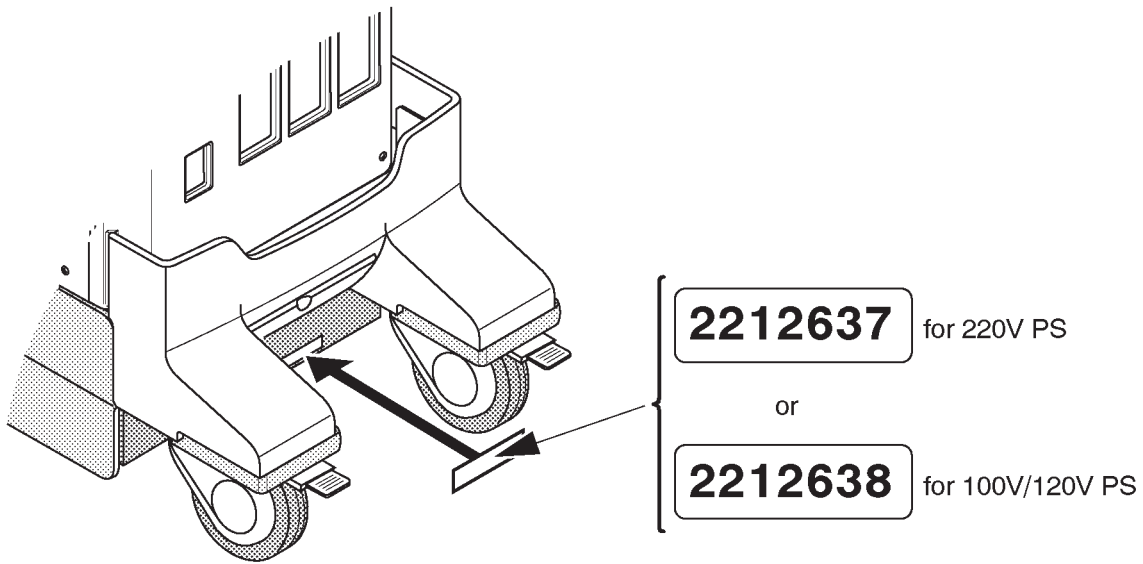

ATTACHING PN LABEL
ILLUSTRATION 6-172

Note

Two types of Indication labels are supplied with the LV3 Unit. One indicates the part number of the 220V Power Supply Unit and another indicates the part number of the 100/120V Power Supply Unit. Be sure to choose and attach the appropriate one.

7-1 INTRODUCTION

This chapter provides Periodic Maintenance procedures. It is an effective and efficient method of reducing equipment down time and service cost.

Note

Cleaning the Air Filters described in this chapter should be done by the customer following the procedures described in the LOGIQ™ 400 User Manual.

It is recommended that the Air Filter Cleaning be included as part of the periodic maintenance procedures performed on site with a maintenance contract.

7-1-1 Periodic Maintenance

Periodic Maintenance consists of visual inspections, system performance checks and periodic cleaning of certain critical parts. Perform this procedure at six month intervals. This schedule for maintenance is based on an estimated equipment usage of 40 hours per week.

7-2 PERIODIC MAINTENANCE PROCEDURE

7-2-1 Visual Inspection

- a. Check cables for cracks nicks and abrasions of their insulation.
- b. Check that cables sheath are securely clamped in cable glands/connector clamps where applicable.
- c. Check that cables are correctly routed and secured.
- d. Check that all screws are in place and not missing.
- e. Check that all detachable cable connectors are fully home in their sockets.
- f. Check that all equipment covers and fixing are in place and undamaged.
- g. Check that all plug-in boards are fully seated in cardcage connector.
- h. Check operation of the cooling fans and that the airflow paths are clear. LOGIQ™ 400 has five Fans : three for PC Boards, one for Power Supplies, one for MO drive.
- i. Check that the keyboard keys, some volumes and Track Ball have correct function and no mechanical damage.
- j. Check that three Air Filters indicated in the ILLUSTRATION 7-2 are clean and undamaged.

7-2-2 Cleaning

a. Clean the CRT filter.

a-1. Remove the CRT filter from the monitor. Refer to section 6-2-6 or 6-2-16 in Chapter 6, RENEWAL PARTS.



Equipment damage possibility. Do not use a hydrocarbon glass cleaner on a monitor with an anti-glare shield. Prolonged use of such cleaners damages the shield.

a-2. Wipe the monitor face and CRT filter using a soft, non-abrasive folded cloth with a glass cleaner.

a-3. Install the CRT filter after cleaning the monitor face and CRT filter. Set the CRT filter on the monitor, insert the CRT filter clamps (①), and slide them inwards securely (②).

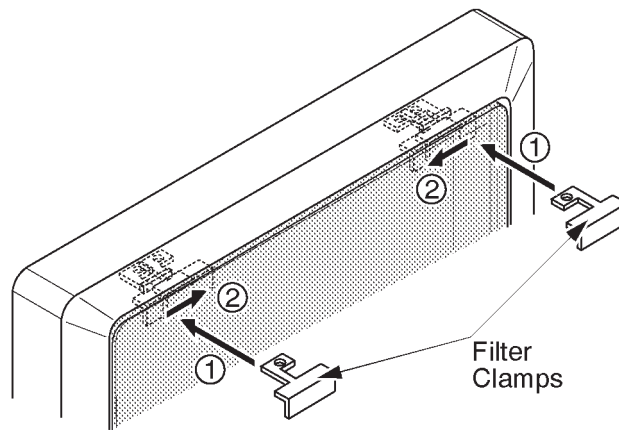

INSTALLING CRT FILTER AND CLAMPS
ILLUSTRATION 7-1

Note

Make sure that the filter is securely fixed by the filter clamps. These are important to prevent a hazard from the filter falling. A “click” sound will be heard when the filter clamp is secured by the lock mechanism.

Note

The CRT Filter Clamps and Escutcheon mounted on the black and white monitor for the LOGIQ™ 400 B/W console are changed to strengthen the mounting grip of the CRT filter on the escutcheon. With these changes, the CRT Filter Clamp Kit are provided to improve the installed base systems. This is:

PART NAME	QTY	PART #	REMARKS
CRT Filter Clamp P Kit	1	2152056	For CRT FILTER (plastic filter, P9514BY)

7-2-2 Cleaning (Continued)

- b. Clean the Fans and the Finger Guards by using a vacuum cleaner and bristled brush.
- c. Clean two Air Filters and one PW Air Filter by using a bristled brush. If these filters are damaged, replace them. For the positions of three Air Filters, refer to ILLUSTRATION 7-2.

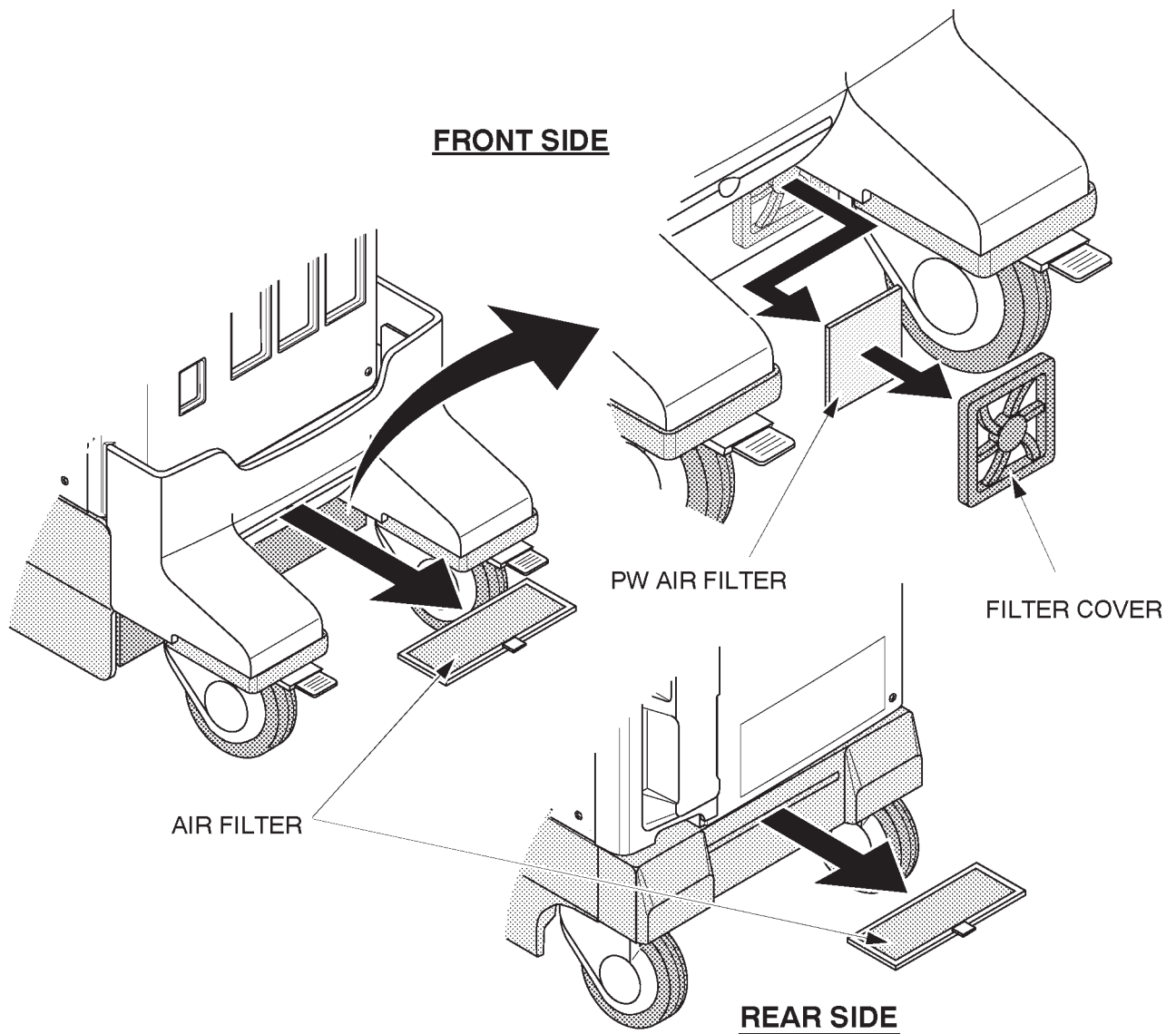

AIR FILTERS REMOVAL
ILLUSTRATION 7-2

- d. Clean out the interior of the Console by using a vacuum cleaner.

7-2-3 Measurement

- a. Make sure that electrical outlet of hospital should provide the power line standard.
Refer to Chapter 2, Installation.
- b. Ensure all power supply voltages are within tolerance.
Refer to section 4-4, Power Supply Adjustment in Chapter 4, Functional Checks, for adjustment procedure.

7-2-4 User Data Backup

- a. Keep user preset data into a MO (Magneto Optical) disk using the User Data Backup of LOGIQ™ 400 Utility Menu. Refer to 4-3-3, Utility Menu in Chapter 4, FUNCTIONAL CHECKS.

Note

Use new initialized MO disk. It is impossible to save any user data files into the disk which another file is already stored.

7-2-5 Note

Visual inspection of probes (“head”, cable and connector)

7-3 ELECTRICAL SAFETY TESTS

The following tests are performed at the factory and should be performed at the site. These tests are: grounding continuity, chassis leakage current, probe leakage current, and ECG leakage current. All measurements are made with an Electrical Safety Analyzer Model Dale 600/600E built by Dale Technology Corporation or equivalent device.

Note

In GEMS–America region, it is NOT necessary to do the leakage current test when installing the LOGIQ™ 400 systems on condition that no optional devices are installed with the console. For more details, contact your regional service support center.

Recommended Tool

<u>PART NUMBER</u>	<u>NAME</u>	<u>DESCRIPTION</u>
46-285652G1	Electric Safety Analyzer DALE 600	For 120V Units
46-328406G2	Electric Safety Analyzer DALE 600E	For 220V Units
2113015	Leakage Current Ultrasound Kit	For 120V and 220V Units

7-3-1 Outlet Test Wiring Arrangement

Test all outlets in the area for proper wiring arrangement by plugging in the Dale 600/600E and noting the combination of lights that are illuminated (Refer to ILLUSTRATION 7-3).

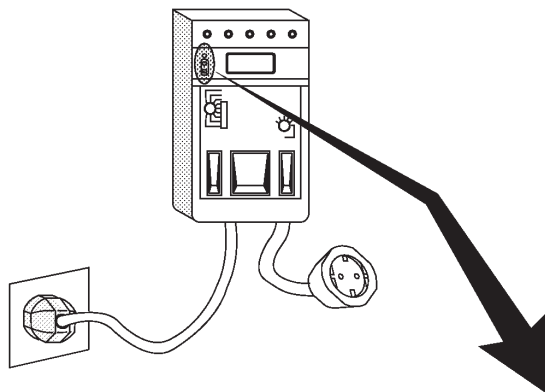

Combination of Lights	● ☀ ☀	☀ ☀ ●	● ☀ ●	● ● ●	☀ ● ☀
Condition	CORRECT WIRING	REVERSE POLARITY	OPEN GROUND	OPEN HOT	HOT/GROUND REVERSED

OUTLET TEST
ILLUSTRATION 7-3

Note

No outlet tester can detect the condition where the Neutral (grounded supply) conductor and the Grounding (protective earth) conductor are reversed. If later tests indicate high leakage currents, this should be suspected as a possible cause and the outlet wiring should be visually inspected.

7-3-2 Grounding Continuity



Electric Shock Hazard. The patient must not be contacted to the equipment during this test.

Measure the resistance from the third pin of the attachment plug to the exposed metal parts of the case (ILLUSTRATION 7-4). The ground wire resistance should be less than **0.2** ohms.

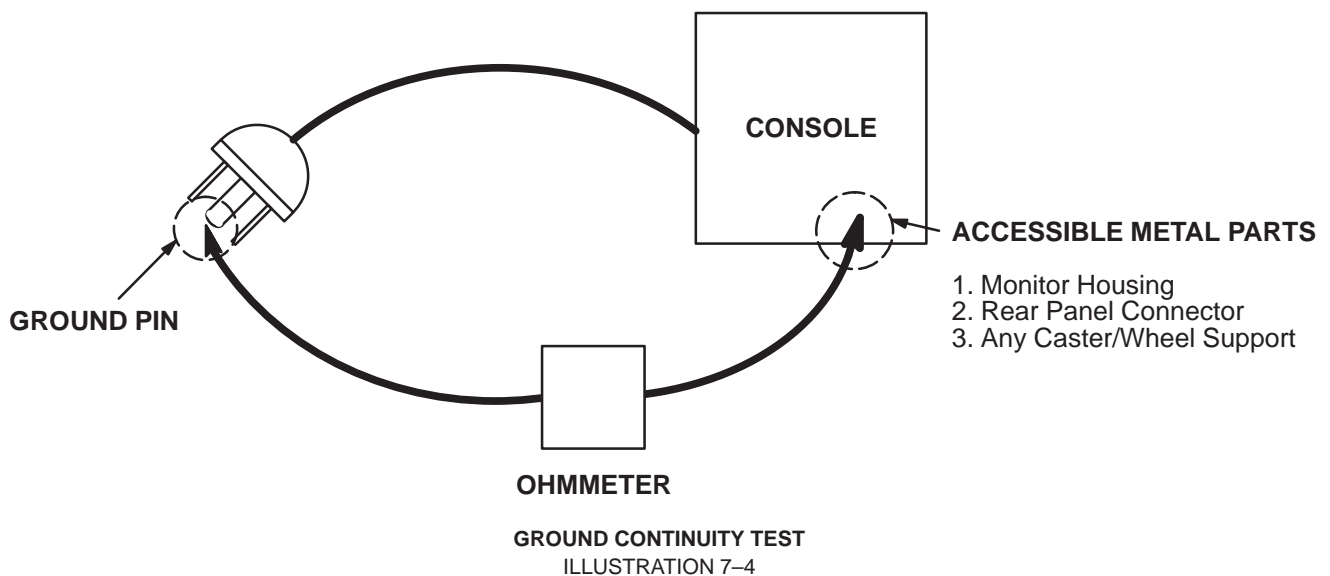

Meter Procedure

Follow these steps to test the ground wire resistance.

1. Turn the LOGIQ™ 400 unit OFF.
2. Plug the unit into the meter, and the meter into the tested AC wall outlet (Refer to ILLUSTRATION 7-6).
3. Plug the black chassis cable into the meter's "CHASSIS" connector and attach the black chassis cable clamp to an exposed metal part of the LOGIQ™ 400 unit (Refer to ILLUSTRATION 7-6).
4. Set the meter's "FUNCTION" switch to the RESISTANCE position.
5. Set the meter's "POLARITY" switch to the OFF (center) position.
6. Measure the ground wire resistance and keep a record of the results with other hard copies of PM data kept on site.

7-3-3 Chassis Leakage Current Test

Definition

Leakage current is the electrical current that could flow through the patient or sonographer should a ground wire break. The unit, the probes, the ECG module, and all external peripherals must be tested.

Generic Procedure

The test verifies the isolation of the power line from the chassis. The testing meter is connected from accessible metal parts of the case to ground. Measurements should be made with the unit ON and OFF, with the power line polarity Normal and Reversed. **Record the highest reading of current.**

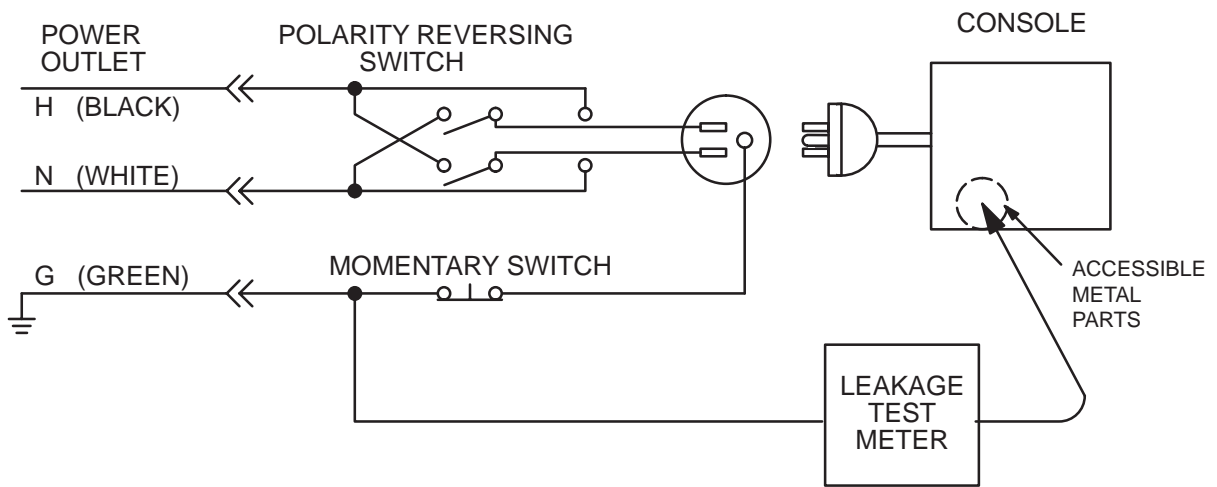

SETUP FOR CHASSIS SOURCE LEAKAGE CURRENT
ILLUSTRATION 7-5

7-3-3 Chassis Leakage Current Test (Continued)

Meter Procedure

Follow these steps to test the unit for leakage current.

1. Turn the LOGIQ™ 400 unit OFF.
2. Plug the unit into the meter, and the meter into the tested AC wall outlet (Refer to ILLUSTRATION 7-6).

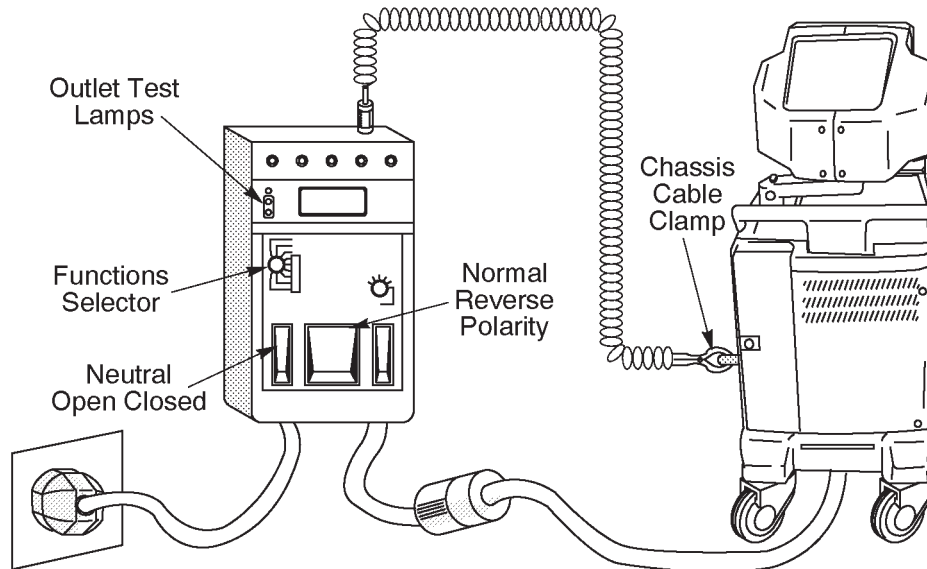

GROUND AND CHASSIS LEAKAGE CURRENT TEST
ILLUSTRATION 7-6

3. Plug the black chassis cable into the meter’s “CHASSIS” connector and attach the black chassis cable clamp to an exposed metal part of the LOGIQ™ 400 unit (Refer to ILLUSTRATION 7-6).
4. Set the tester’s “FUNCTION” switch to CHASSIS position.
5. Follow the test conditions described in the following table for every test point on the unit.

TABLE 7-1
CHASSIS LEAKAGE CURRENT TEST CONDITIONS

TEST	CONDITION
1	Mounting screw for transducer receptacle
2	Wheel support
3	Mounting screw for CRT housing
4	Mounting screw for peripheral plugged into unit
5	Mounting screw for other peripheral powered by unit

6. Keep a record of the results with other hard copies of PM data kept on site.

7-3-3 Chassis Leakage Current Test (Continued)

Data Sheet for Chassis Source Leakage Current

Follow the foregoing test procedure. The test passes when all readings measure less than the value shown in the table below (TABLE 7-2).

TABLE 7-2
MAXIMUM ALLOWANCE LIMIT FOR CHASSIS SOURCE LEAKAGE CURRENT

COUNTRY	NORMAL CONDITION	OPEN GROUND	REVERSE POLARITY	OPEN NEUTRAL
USA	N/A	0.3mA	0.3mA	N/A
OTHERS	0.1mA	0.5mA	0.5mA	0.5mA



Electric Shock Hazard. When the meter's ground switch is OPEN, don't touch the unit!



Equipment damage possibility. Never switch the Polarity and the status of Neutral when the unit is powered ON. Be sure to turn the unit power OFF before switching them using the POLARITY switch and/or the NEUTRAL switch. Otherwise, the unit may be damaged.

TABLE 7-3
DATA SHEET FOR CHASSIS SOURCE LEAKAGE CURRENT

Unit Power	Tester POLARITY Switch	Tester NEUTRAL or GROUND Switch	Test1 Probe connector	Test2 wheel	Test3 CRT	Test4	Test5
Enter name of tested peripheral here:							
ON	NORM	OPEN					
ON	NORM	CLOSED					
ON	REV	OPEN					
ON	REV	CLOSED					
OFF	NORM	OPEN					
OFF	NORM	CLOSED					
OFF	REV	OPEN					
OFF	REV	CLOSED					

7-3-4 Probe Leakage Current Test

Definition

This test measures the current that would flow to ground from any of the probes through a patient who is being scanned and becomes grounded by touching some other grounded surface.

Generic Procedure

Measurements should be made with the ground open and closed, with power line polarity normal and reversed, and with the unit Off and On. For each combination, the probe must be active to find the worst case condition.

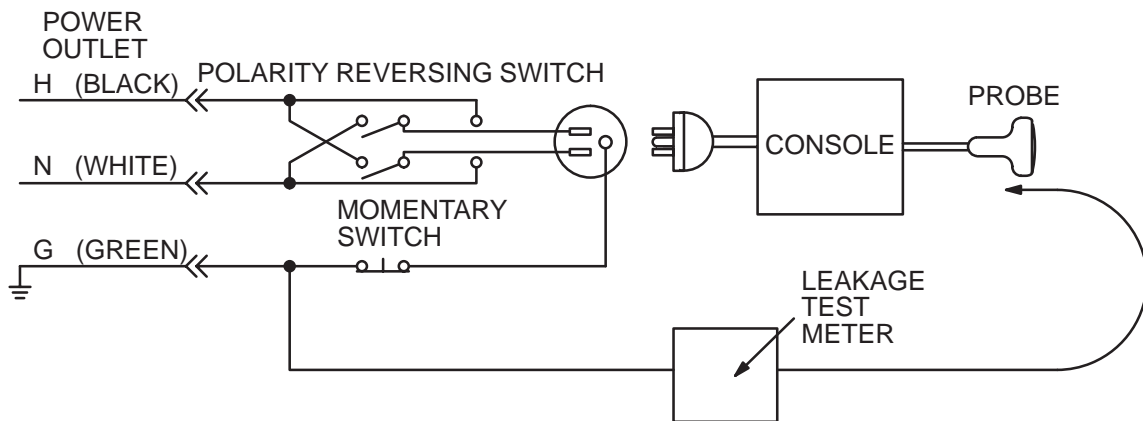

SETUP FOR PROBE LEAKAGE CURRENT
ILLUSTRATION 7-7

Note

Each probe will have some amount of leakage current, dependent on its design. Small variations in probe leakage currents are normal from probe to probe. Other variations will result from differences in line voltage and test lead placement.

7-3-4 Probe Leakage Current Test (Continued)

Meter Procedure Using Probe Adapter

The Dale 600/600E provides a method for testing probes independently from the system. The meter utilizes a probe adapter to apply a test potential commonly to all connector pins.

The probe's imaging area is immersed in a saline solution along with a grounding probe from the meter to complete the current path. Saline solution is a mixture of water and salt. The salt adds a free ion to the water, making it conductive. Normal saline solution is 0.9% salt or 1/2 gram salt per 1 liter of water. If saline is not available, a mixture of 1 quart water with one or more grams of table salt, mixed thoroughly, will substitute.

CAUTION

To avoid probe damage and possible electric shock, do not immerse probes into any liquid beyond the level indicated in the probe users manual. Do not touch the probe, conductive liquid or any part of the unit under test while the ISO TEST switch is depressed.

Follow these steps to test each transducer for leakage current.

1. Turn the LOGIQ™ 400 unit OFF.
2. Plug the unit into the test meter, and the meter into the tested AC wall outlet.
3. Connect the probe for test with the meter's appropriate adapter (Refer to ILLUSTRATION 7-8).
4. Plug the saline probe into the meter's "CHASSIS" connector (Refer to ILLUSTRATION 7-8).

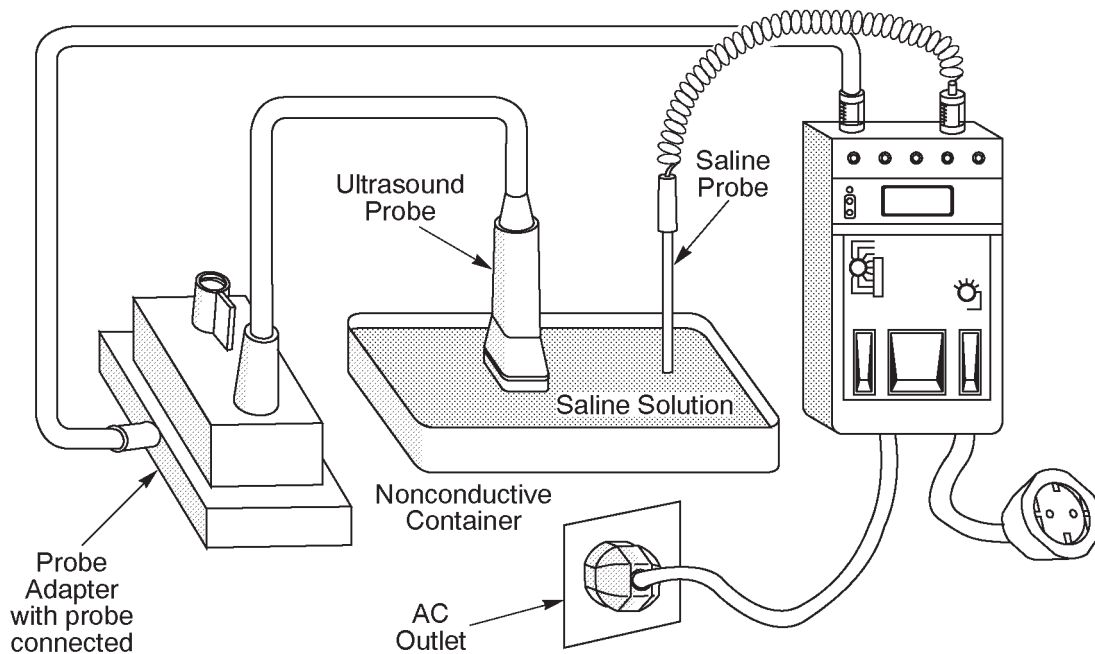

TRANSDUCER SOURCE LEAKAGE CURRENT TEST

ILLUSTRATION 7-8

7-3-4 Probe Leakage Current Test (Continued)

5. Plug the probe adapter into the meter's connector marked "EXTERNAL" (Refer to ILLUSTRATION 7-8).
6. Set the meter's "FUNCTION" switch to EXTERNAL position.
7. Add the saline probe and the imaging area of the probe into the saline bath.
8. Have unit power ON for the first part; turn it OFF for the second half.
9. Depress the ISO TEST rocker switch and record the highest current reading.
10. Follow the test conditions described in the following table (TABLE 7-5) for every transducer.
11. Keep a record of the results with other hand copies of PM data.

Meter Procedure

Follow these steps to test each transducer for leakage current.

1. Turn the LOGIQ™ 400 unit OFF.
2. Plug the unit into the test meter, and the meter into the tested AC wall outlet.
3. Plug the external probe into the meter's "EXTERNAL" connector.
4. Set the meter's "FUNCTION" switch to EXTERNAL position.
5. Connect the probe for test with the connector of the console.
6. Apply a liberal amount of gel to the transducer's lens.
7. Wrap the transducer in aluminum foil, making sure there is good contact with its acoustic aperture.
8. Either suspend the transducer by its cable or place it on an insulated surface.
9. Have unit power ON for the first part; turn it OFF for the second half.
10. Hold the external probe against the aluminum foil on the transducer when the unit is ready to scan.
11. Depress the ISO TEST rocker switch and record the highest current reading.
12. Follow the test conditions described in the following table (TABLE 7-5) for every transducer.
13. Keep a record of the results with other hand copies of PM data.

7-3-4 Probe Leakage Current Test (Continued)

Data Sheet for Transducer Source Leakage Current

Follow the foregoing test procedure for every transducer. The test passes when all readings measure less than the value shown in the table below (TABLE 7-4).

TABLE 7-4
MAXIMUM ALLOWANCE LIMIT FOR PROBE LEAKAGE CURRENT

1. Type BF Applied Part Leakage Current Limits
 [Non-conductive (floating) Surface and Cavity Transducers]

COUNTRY	NORMAL CONDITION	OPEN GROUND	REVERSE POLARITY	OPEN NEUTRAL
USA	0.05mA	0.05mA	0.05mA	0.05mA
OTHERS	0.1mA	0.5mA	0.5mA	0.5mA

2. Type CF Applied Part Leakage Current Limits
 [Surgical Transducer and ECG Connections]

COUNTRY	NORMAL CONDITION	OPEN GROUND	REVERSE POLARITY	OPEN NEUTRAL
USA	0.01mA	0.01mA	0.01mA	0.01mA
OTHERS	0.01mA	0.05mA	0.05mA	0.05mA



Equipment damage possibility. Never switch the Polarity and the status of Neutral when the unit is powered ON. Be sure to turn the unit power OFF before switching them using the POLARITY switch and/or the NEUTRAL switch. Otherwise, the unit may be damaged.

TABLE 7-5
DATA SHEET FOR TRANSDUCER SOURCE LEAKAGE CURRENT

Transducer tested:			
LOGIQ™ 400 Unit Power	Tester Power POLARITY Switch	Tester GROUND or NEUTRAL Switch	Measurement
ON	NORM	OPEN	
ON	NORM	CLOSED	
ON	REV	OPEN	
ON	REV	CLOSED	
OFF	NORM	OPEN	
OFF	NORM	CLOSED	
OFF	REV	OPEN	
OFF	REV	CLOSED	

7-3-5 ECG Leakage Current Test

Definition

This test measures the current which would flow to ground from any of the isolated ECG leads. The meter simulates a patient who is contacted to the monitoring equipment and is grounded by touching some other grounded surface.

Generic Procedure

Measurements should be made with the ground open and closed, with power line polarity normal and reversed, and with the unit Off and On. For each combination, the operating controls such as the lead switch should be operated to find the worst case condition.

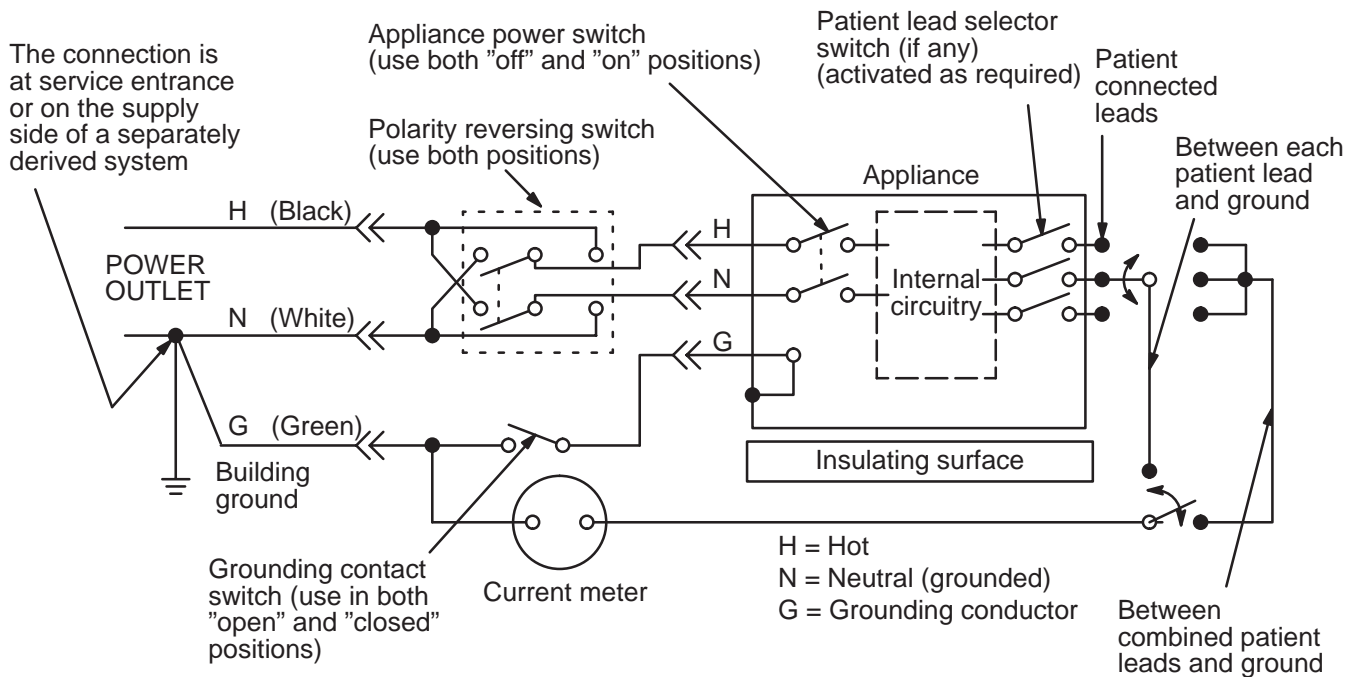

TEST CIRCUIT FOR MEASURING NON-ISOLATED PATIENT LEADS (PROBES & ECG)
ILLUSTRATION 7-9

7-3-5 ECG Leakage Current Test (Continued)

Meter Procedure

The Dale 600/600E provides five snap type ECG buttons for testing patient leads. Snap on all patient leads to the meter and assure that the ground clip is connected to the system's ground terminal.

CAUTION

Line voltage is applied to the ECG leads during this test. To avoid possible electric shock hazard, the system being tested must not be touched by patients, users or anyone while the ISO TEST switch is depressed.

When the meter's ground switch is OPEN, don't touch the unit!

Follow these steps to test the ECG module for leakage current.

1. Turn the LOGIQ™ 400 unit OFF.
2. Plug the unit into the meter, and the meter into the tested AC wall outlet (Refer to ILLUSTRATION 7-10).
3. Plug the black chassis cable into the meter's "CHASSIS" connector and attach the black chassis cable clamp to an exposed metal part of the LOGIQ™ 400 unit (Refer to ILLUSTRATION 7-10).
4. Connect the patient leads to the corresponding snaps located at the upper front of the Dale 600/600E. Lead nomenclature for this test is not important (Refer to ILLUSTRATION 7-10).

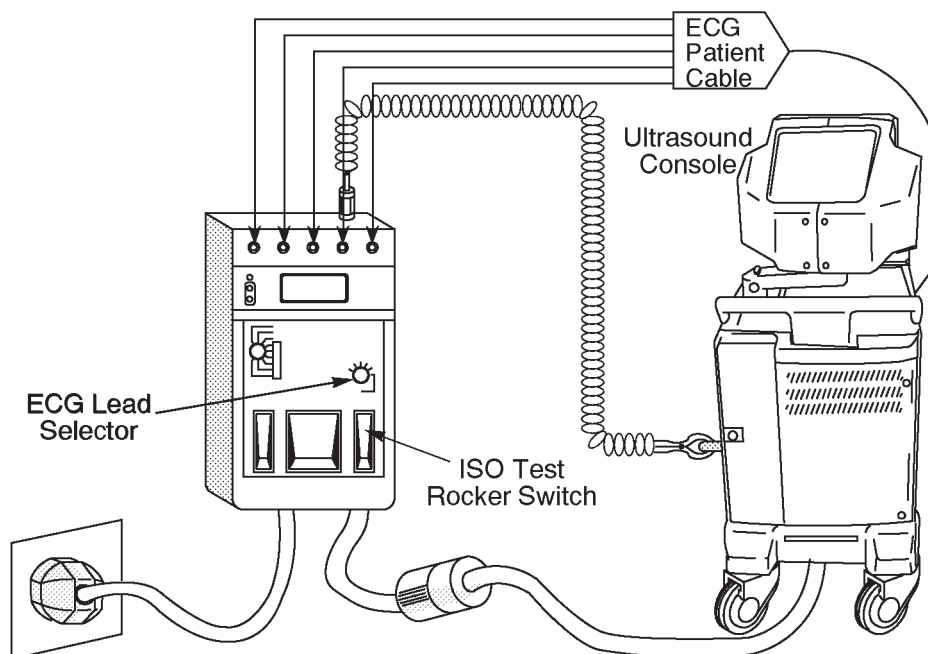

ECG LEAKAGE CURRENT TEST

ILLUSTRATION 7-10

7-3-5 ECG Leakage Current Test (Continued)

5. Set the meter's "FUNCTION" switch to LEAD TO GROUND position to measure the patient lead to ground leakage current.
6. Select and test each ECG lead positions (except ALL) of the LEAD selector, testing each to the power condition combinations shown in TABLE 7-6.

TABLE 7-6
TESTING POWER CONDITIONS

ECG Power	Meter's Polarity Switch	Meter's Neutral Switch
ON	NORM	CLOSED
ON	NORM	OPEN
ON	REVERSE	CLOSED
ON	REVERSE	OPEN
OFF	NORM	CLOSED
OFF	NORM	OPEN
OFF	REVERSE	CLOSED
OFF	REVERSE	OPEN

7. Record the patient lead to ground leakage current measured on the data sheet (Refer to TABLE 7-8).
8. Set the meter's "FUNCTION" switch to LEAD TO LEAD position to measure the lead to lead leakage current.
9. Select and test each ECG lead positions (except ALL) of the LEAD selector, testing each to the power condition combinations shown in TABLE 7-6.
10. Record the lead to lead leakage current measured on the data sheet (Refer to TABLE 7-8).
11. Set the meter's "FUNCTION" switch to LEAD ISO position to measure the patient lead isolation current.
12. Select and test each ECG lead positions (except ALL) of the LEAD selector, testing each to the power condition combinations shown in TABLE 7-6.
13. Depress the rocker switch to ISO TEST and read the isolation current. To apply the voltage to the lead safely, the voltage is only applied when the rocker switch is depressed to ISO TEST.
14. Record the patient lead isolation current measured on the data sheet (Refer to TABLE 7-8).

7-3-5 ECG Leakage Current Test (Continued)

Data Sheet for ECG Leakage Current

Follow the foregoing test procedure. The test passes when all readings measure less than the value shown in the table below (TABLE 7-7).

TABLE 7-7
MAXIMUM ALLOWANCE LIMIT FOR ECG LEAKAGE CURRENT

	AC POWER SOURCE	MAXIMUM ALLOWANCE LIMIT	
		GROUND OPEN	GROUND CLOSED
Patient Lead to Ground Leakage Current Test and Patient Lead to Lead Leakage Current Test	115V	10 μ A	10 μ A
	220/240V	500 μ A	10 μ A
	AC POWER SOURCE	MAXIMUM ALLOWANCE LIMIT	
Patient Lead Isolation Current Test	115V	20 μ A	
	220/240V	5mA	



Equipment damage possibility. Never switch the Polarity when the unit is powered ON. Be sure to turn the unit power OFF before switching the polarity using the POLARITY switch. Otherwise, the unit may be damaged.

TABLE 7-8
DATA SHEET FOR ECG LEAKAGE CURRENT

Patient Lead Isolation Current Test							
Patient Lead to Lead Leakage Current Test							
Patient Lead to Ground Leakage Current Test							
ECG Power	Tester Polarity Switch	Tester GROUND Switch	Tester Lead Selector				
			RL	RA	LA	LL	C
ON	NORM	CLOSED					
ON	REVERSE	CLOSED					
ON	NORM	OPEN					
ON	REVERSE	OPEN					
OFF	NORM	CLOSED					
OFF	REVERSE	CLOSED					
OFF	NORM	OPEN					
OFF	REVERSE	OPEN					

7-3-6 When There's Too Much Leakage Current...

Chassis Fails

Check the ground on the power cord and plug for continuity. Ensure the ground is not broken, frayed, or intermittent. Replace any defective part.

Tighten all grounds. Ensure star washers are under all ground studs.

Inspect wiring for bad crimps, poor connections, or damage.

Test the wall outlet; verify it is grounded. Notify the user or owner to correct any deviations. As a work around, check the other outlets to see if they could be used instead.

Note

No outlet tester can detect the condition where the white neutral wire and the green grounding wire are reversed. If later tests indicate high leakage currents, this should be suspected as a possible cause and the outlet wiring should be visually inspected.

Probe Fails

Test the probe in another transducer interface connector.

If excessive leakage current is slot dependent, inspect the Transducer Interface board for bent pins, poor connections, and ground continuity.

If the problem still has stayed with the probe, replace the probe.

Peripheral Fails

Tighten all grounds. Ensure star washers are under all ground studs.

Inspect wiring for bad crimps, poor connections, or damage.

Still Fails

If all else fails, begin isolation by removing the probes, external peripherals, then the on board ones, one at a time while monitoring the leakage current measurement.

New Unit

If the leakage current measurement tests fail on a new unit and if situation can not be corrected, submit a Safety Failure Report to document the system problem. Remove unit from operation.

8-1 INTRODUCTION

This chapter provides the installation procedures and renewal parts for optional devices. The installation procedures for the following optional devices are included in this chapter.

Video Cassette Recorder	:	Sony SVO-9500
Color Video Printer	:	Sony UP-1850 and UP-2950 Series Printers
B/W Video Printer	:	Sony UP-890
ECG		
Expanded Cine Memory		
Foot Switch		
Swivel Lock		
Left Side Probe Holder		
MTZ Probe Holder		

8-2 VIDEO CASSETTE RECORDER INSTALLATION

8-2-1 Foreword

This section describes the installation of the optional Sony SVO-9500MD (NTSC)/SVO-9500MDP (PAL) Video Cassette Recorder for LOGIQ™ 400.

There are two ways for fixing the VCR on the LOGIQ™ 400. Two ways are:

- a. Installing the VCR on the Console.
- b. Installing the VCR on the Color Monitor.

Note

It is not possible to install the VCR or other peripherals onto the B/W monitor. Do not put any objects on the top of monitor.

Regarding installation procedure for each way, refer to 8-2-6, Installing VCR on Console or 8-2-7, Installing VCR on Color Monitor, Procedures, respectively.

8-2-2 Tools Required

Standard field Service Tool kit.

8-2-3 Time Required

Approx. 1 hour for installing the VCR on the console
 Approx. 1.5 hour for installing the VCR on the color monitor

8-2-4 Parts Required

a. When installing the VCR on the Console:

ITEM	PART NAME	QTY	PART #	REMARKS
1.	Video Cassette Recorder	1	—	SVO-9500MD for NTSC SVO-9500MDP for PAL (E11801AA)
2.	VTR Assy	1	2127668	
	Option Tray 1	1	2127115	
	Option Tray 2	1	2127116	
	Edging	1	U0507AC	
	Screw	4	—	
	Screw	8	—	
3.	Power Cable Assy	1	P9509EE	
4.	RS232C Cable Assy	1	P9509MN	

Note

SVO-9500MDP (PAL) includes the video cables.

8-2-4 Parts Required (Continued)

b. When installing the VCR on the Color Monitor:

ITEM	PART NAME	QTY	PART #	
1.	Video Cassette Recorder	1	—	SVO-9500MD for NTSC SVO-9500MDP for PAL (E11801AA)
2.	VTR on Monitor Assy	1	P9522YE	
	VTR Base	1	P9524JY	
	VTR Belt	1	P9524JT	
	Stopper Block	1	P9524HH	
	Plate	2	P9524JN	
	Caution Label	1	P9524PU	
	Screw	4	—	
	Screw	4	—	
3.	Power Cable Assy	1	P9509EE	
4.	RS232C Cable Assy	1	P9509MN	

8-2-5 Functional Check-out

READ and UNDERSTAND these instructions thoroughly before proceeding with the installation. Perform each step in sequence and check it off when completed. If a problem occurs after completion, go back through the procedure and check for implementation errors before contacting your Ultrasound Region Engineer.



Equipment damage possibility. If the video cassette recorder is installed on the monitor, it is necessary to lock the monitor's tilt and up/down mechanism to prevent the equipment damage. Call customer's attention to that effect.



Possible operational damage. Failure to strictly follow ESD (Electrostatic Discharge) precautions during this upgrade may cause constant or intermittent operational abnormalities. Strictly follow all precautions.

Check each step as it is completed.

Perform functional checks to verify that the system is functioning properly. Refer to Chapter 4, Functional Checks.

8-2-6 Installing VCR on Console

1. Turn the system power OFF and unplug the unit. Follow the OSHA Lockout/Tagout Requirements (29 CFR 1910.147, Direction 46-015902).
2. Remove the Top Cover Sheet out of the system. Refer to ILLUSTRATION 8-1
3. Raise the monitor up by pushing down the Up/Down Release Button located on the Monitor Arm. Refer to ILLUSTRATION 8-1.

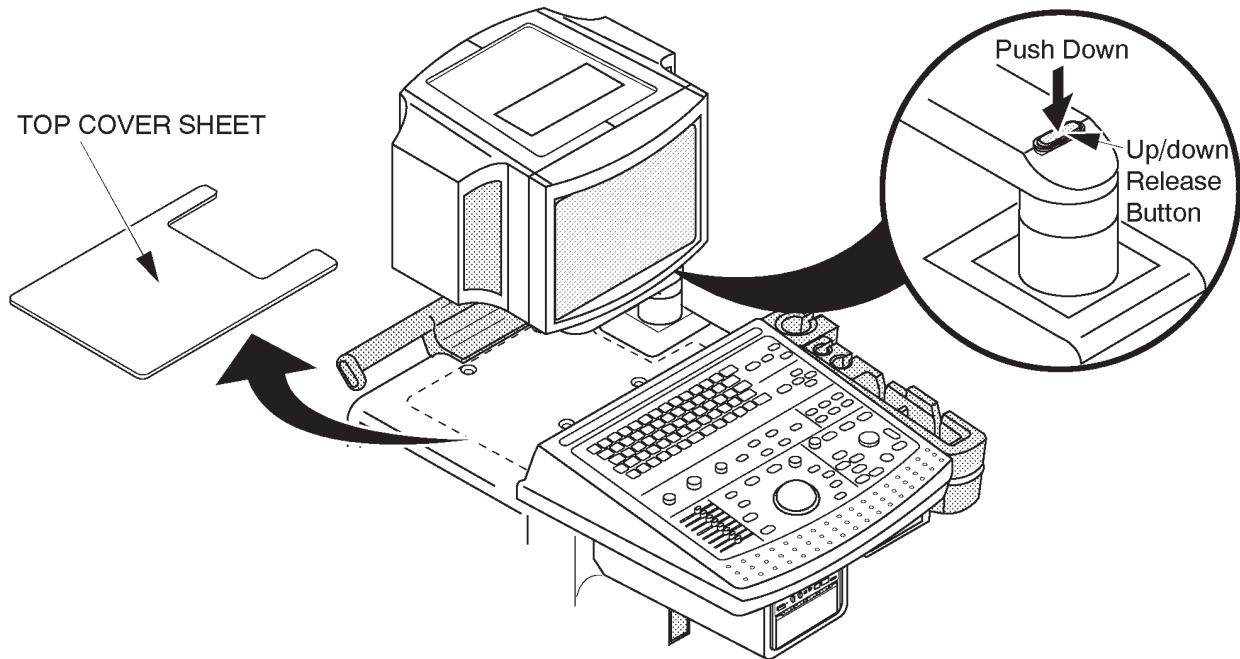

CONSOLE
ILLUSTRATION 8-1

8-2-6 Installing VCR on Console (Continued)

4. Put the OPTION TRAY 1 on the console and screw four screws supplied with VTR ASSY (2127668) to fix the OPTION TRAY 1 as shown in ILLUSTRATION 8-2.

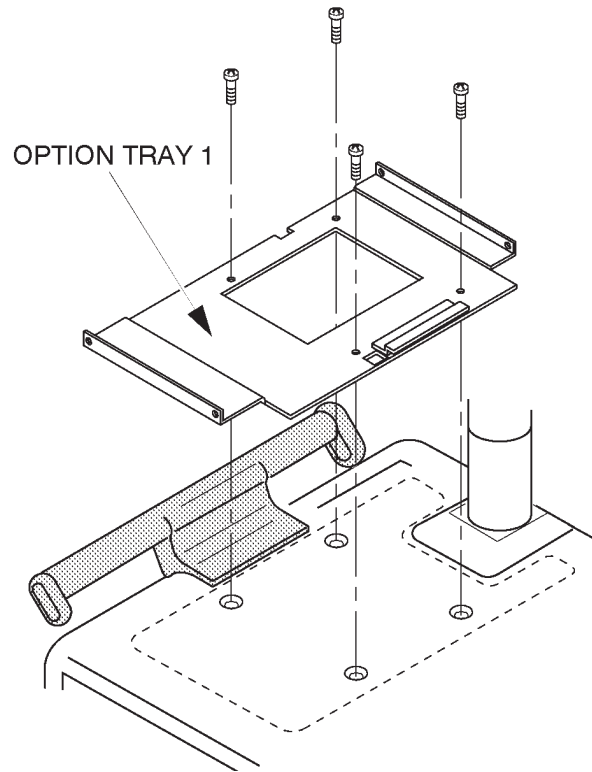

OPTION TRAY 1 INSTALLATION
ILLUSTRATION 8-2

8-2-6 Installing VCR on Console (Continued)

- 5. Unscrew four screws fixing the rubber feet of the Video Cassette Recorder as shown in ILLUSTRATION 8-3.

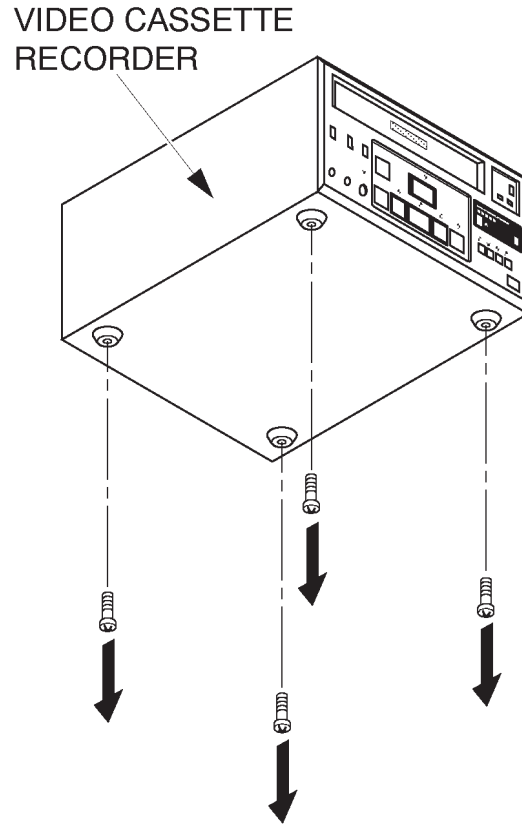

VIDEO CASSETTE RECORDER
ILLUSTRATION 8-3

8-2-6 Installing VCR on Console (Continued)

6. Screw four screws supplied with VTR ASSY (2127668) to install the OPTION TRAY 2 to the Video Cassette Recorder as shown in ILLUSTRATION 8-4.

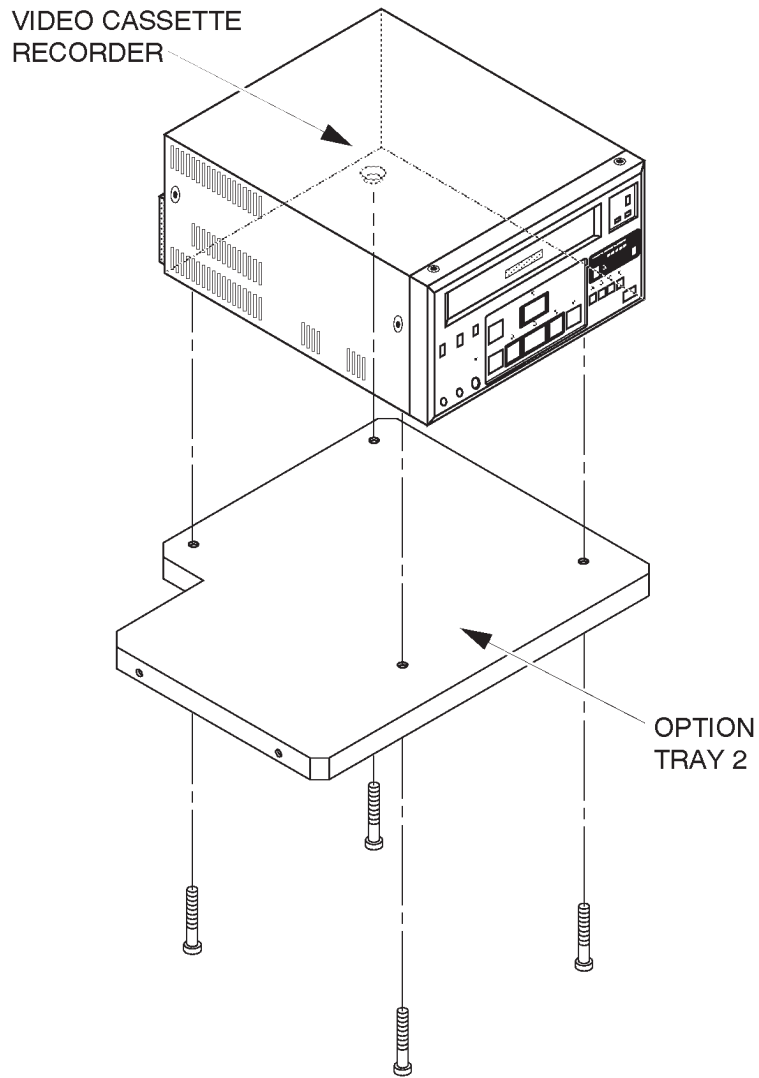

TRAY INSTALLATION
ILLUSTRATION 8-4

8-2-6 Installing VCR on Console (Continued)

7. Place the OPTION TRAY 2 with the Video Cassette Recorder on the OPTION TRAY 1 and screw four screws supplied with VTR ASSY (2127668) as shown in ILLUSTRATION 8-5.

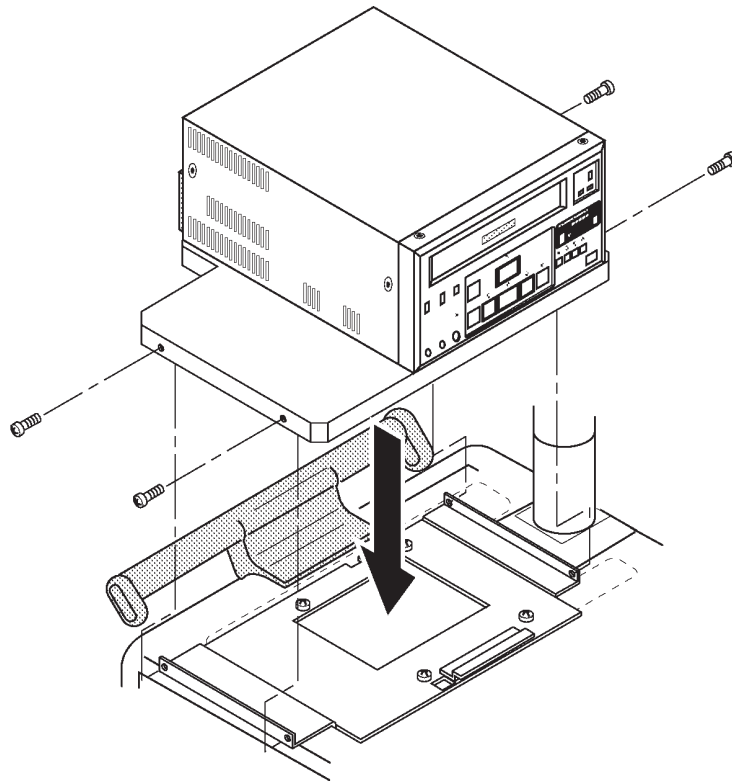

FIXING TRAY
ILLUSTRATION 8-5

8-2-7 Installing VCR on Color Monitor

1. Turn the system power OFF and unplug the unit.
2. Remove four seals blinding the screw hole from the top of Color Monitor.

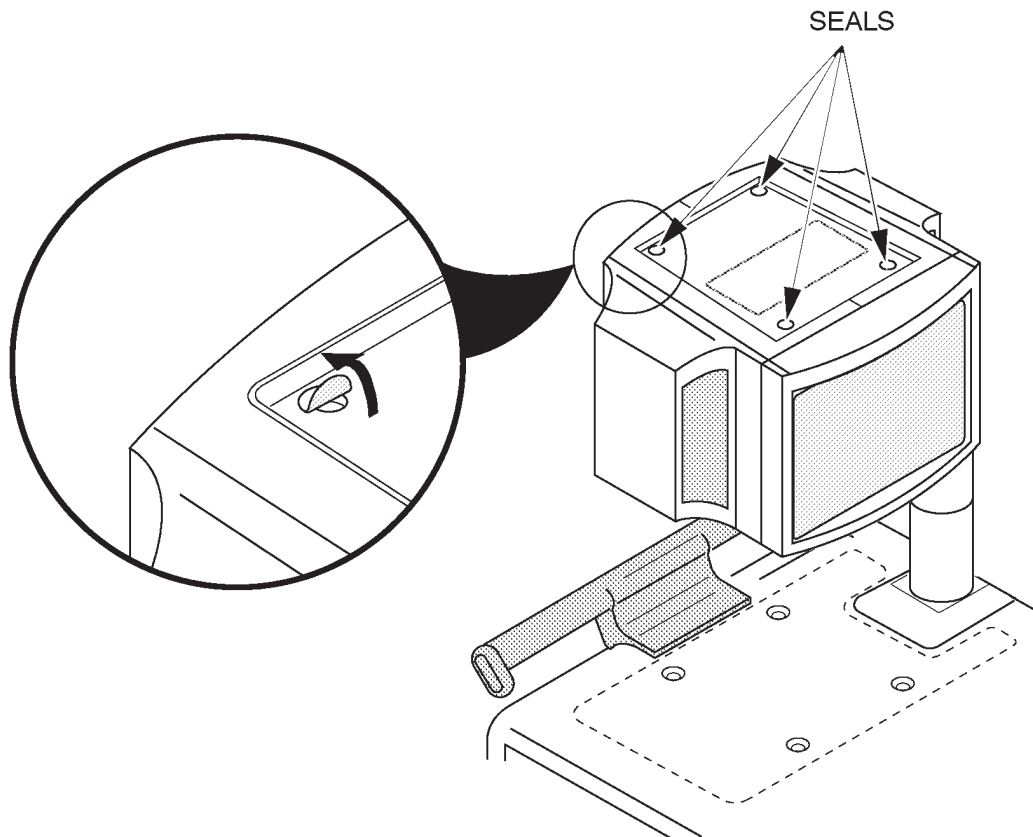

SEALS REMOVAL
ILLUSTRATION 8-6

8-2-7 Installing VCR on Color Monitor (Continued)

3. Remove the Monitor Cover Left and Monitor Cover Right. Refer to the 6-2-2 in Chapter 6, Renewal Parts.
4. Remove the left and right speakers. Refer to the 6-2-8 in Chapter 6, Renewal Parts.
5. Install the Plates to the Monitor at the both left and right side as shown in ILLUSTRATION 8-7. Use four screws supplied with the VTR ON MONITOR ASSY (P9522YE) to fix the Plates.
6. Attach the Stopper Block on the Monitor Arm so as to cover the Up/down Release Button. Refer to ILLUSTRATION 8-7.

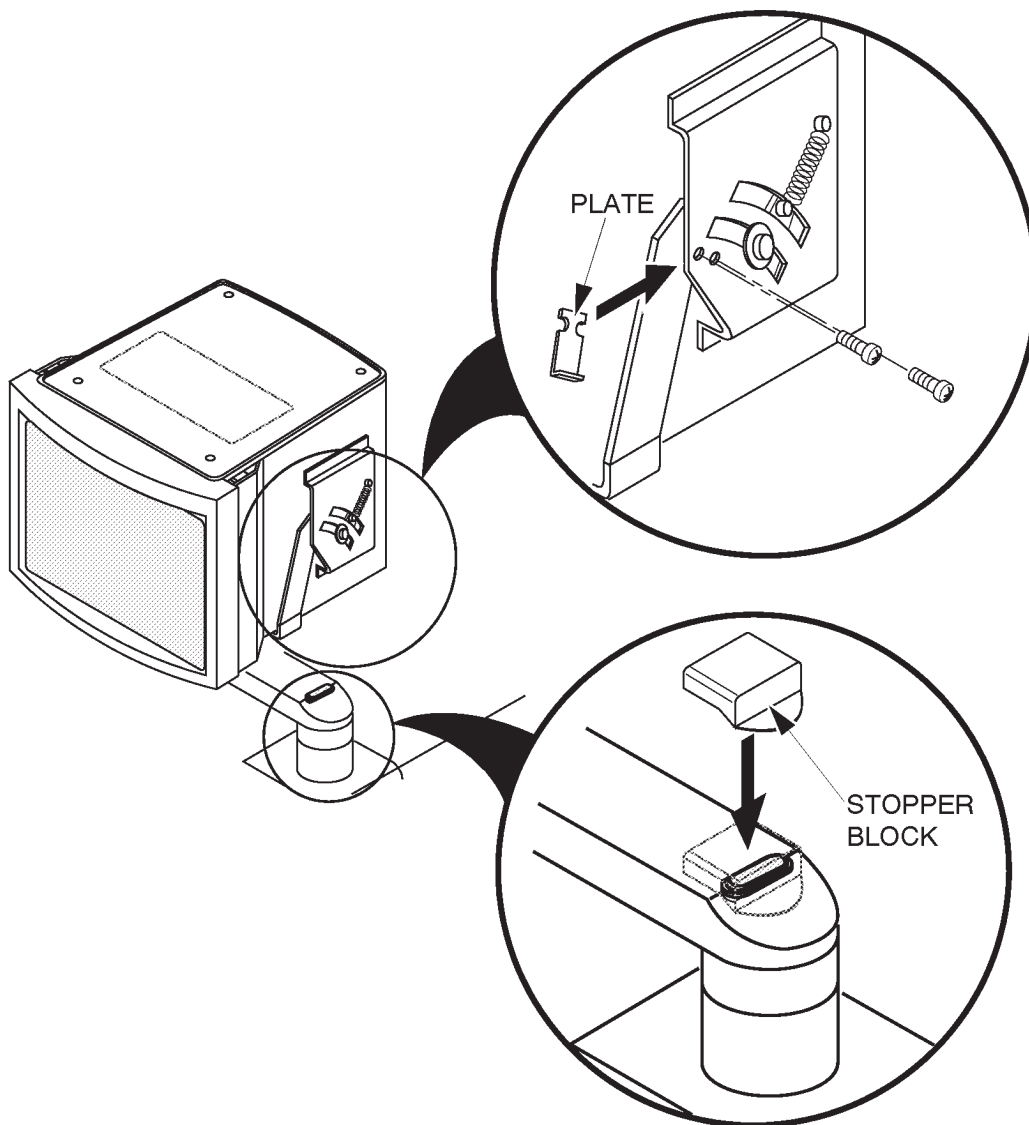

PLATES AND STOPPER BLOCK INSTALLATION
ILLUSTRATION 8-7

8-2-7 Installing VCR on Color Monitor (Continued)

7. Install the speakers removed.
8. Install the Monitor Cover Left and Right removed.
9. Screw four screws supplied with VTR ON MONITOR ASSY (P9522YE) to install the VTR BASE onto the console as shown in ILLUSTRATION 8-8.

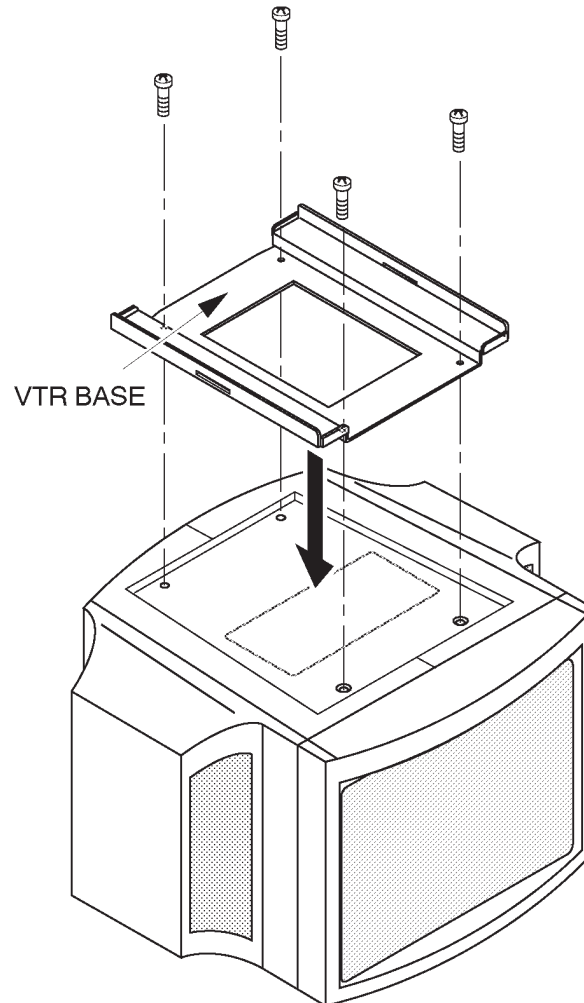

VTR BASE INSTALLATION
ILLUSTRATION 8-8

8-2-7 Installing VCR on Color Monitor (Continued)

10. Pass the VTR BELT (supplied with the VTR on Monitor Assy, P9522YE) through the two slits of the VTR BASE as shown in ILLUSTRATION 8-9.

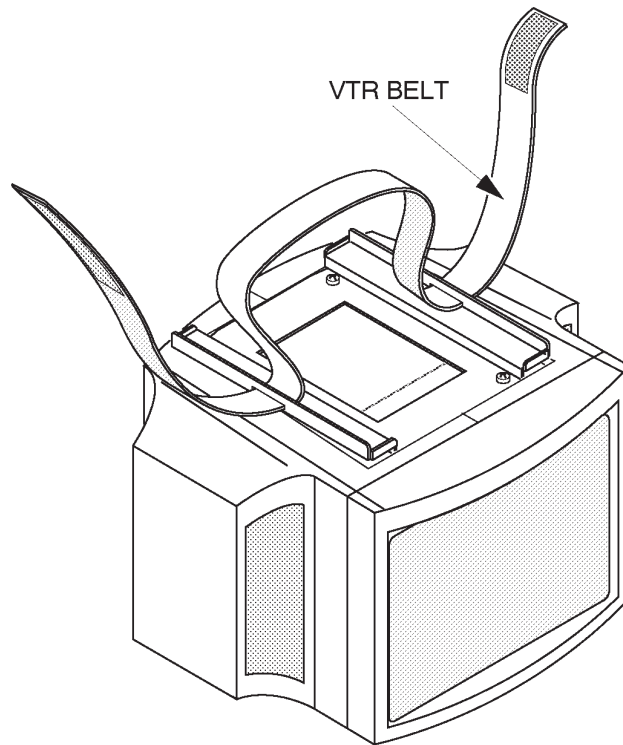

VTR BELT
ILLUSTRATION 8-9

8-2-7 Installing VCR on Color Monitor (Continued)

11. Put the Video Cassette Recorder onto the VTR BASE and fix the VCR with the VTR BELT. Refer to ILLUSTRATION 8-10.

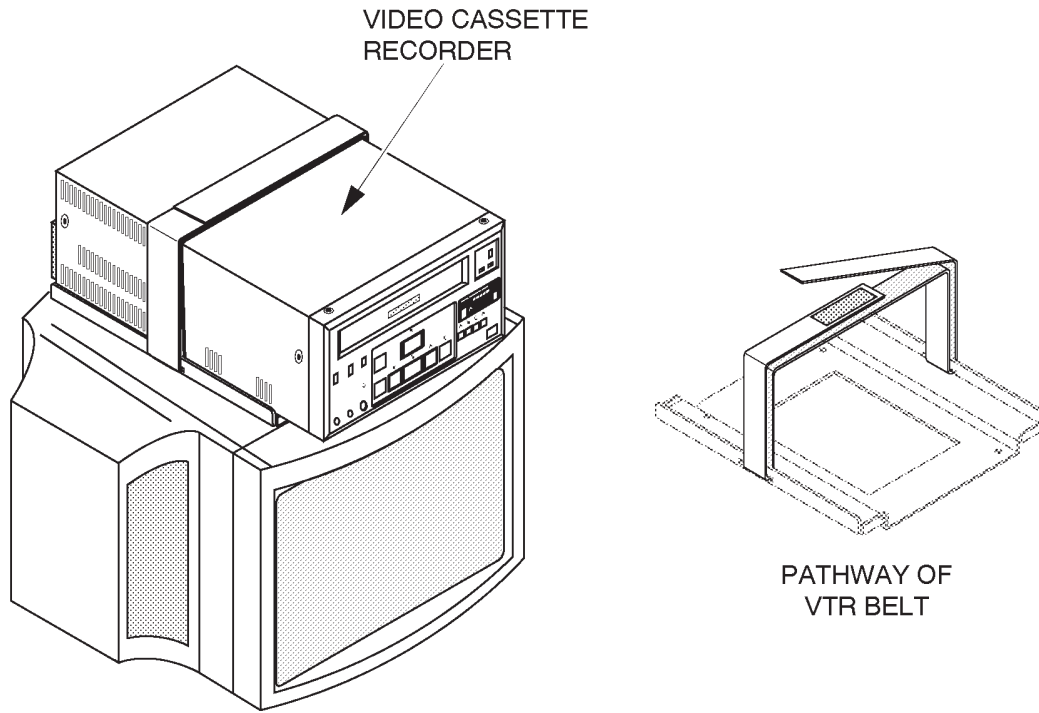

OPTION TRAY FIXATION
ILLUSTRATION 8-10

8-2-7 Installing VCR on Color Monitor (Continued)

12. Attach the Caution Label (supplied with the VTR on Monitor Assy, P9522YE) onto the Video Cassette Recorder. Refer to ILLUSTRATION 8-11.

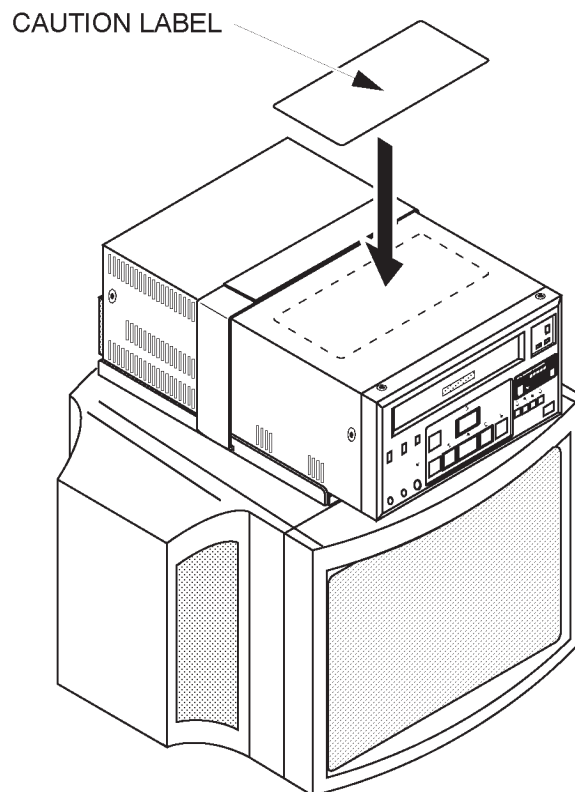

CAUTION LABEL
ILLUSTRATION 8-11

8-2-8 Connecting Cables



Use only the exclusive power cable to supply power to the peripheral recording devices from the LOGIQ™ 400. If a peripheral device is supplied power by other outlet, the system may be damaged by electrical noise transferred with the video signal or may not pass leakage current test.

1. Connect the power cable, RS232C cable, and the two S.Video cables between the Video Cassette Recorder and the console as shown in ILLUSTRATION 8-12.

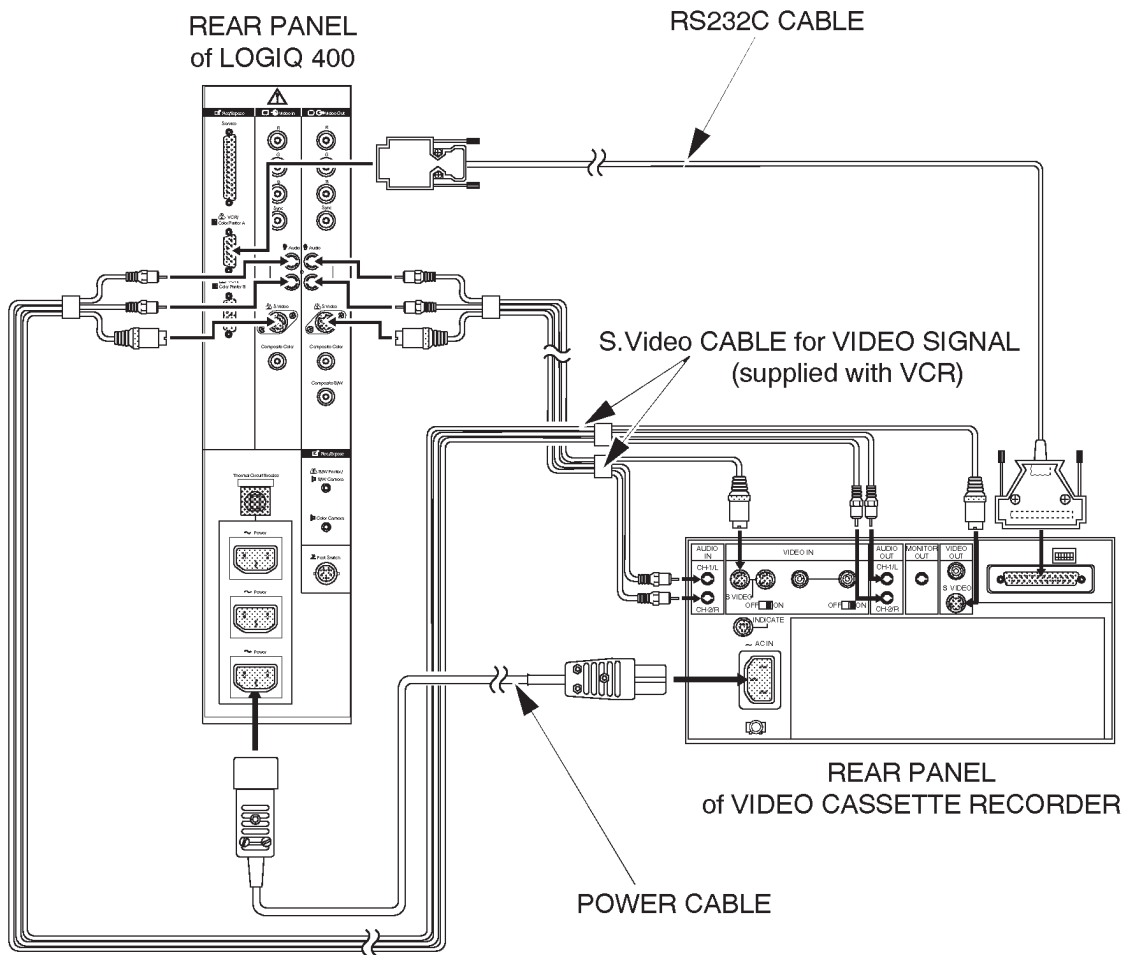

CONNECTING CABLES
ILLUSTRATION 8-12

Note

The arrangement of I/O ports on the Rear Panel of B/W monitor system is different from the Color Monitor System.

8-2-8 Connecting Cables (Continued)

Note

In case of B/W monitor system, the header information data may be displayed on the playback screen when using the S Video connection. It is recommended that the Color Composite connection is used.

Note

The LOGIQ™ 400CL does not provide the VCR remote control function. It is not necessary to connect the RS-232C cable for the remote control with the LOGIQ™ 400CL console.

8-2-9 Setting DIP Switches

1. Set the DIP switches located on the rear panel of the video cassette recorder as shown in ILLUSTRATION 8-13.

Note

The LOGIQ™ 400CL does not provide the VCR remote control function. Set the DIP switched as shown in ILLUSTRATION 8-13.

OTHERS:



LOGIQ™ 400CL:



SW1, 2, 3, 4, 6 : OFF
SW5 : ON



SW1, 2, 3, 6 : OFF
SW4, 5 : ON

DIP SWITCH SETTINGS
ILLUSTRATION 8-13

8-2-10 Operational Check-out

1. Plug in the system and power the system ON.
2. Make sure that the CTL/MENU switch located at the front of VCR is set to the CTL position (upper side).

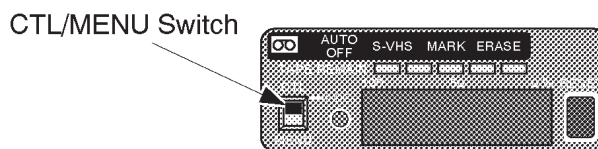

CTL/MENU SWITCH SETTING
ILLUSTRATION 8-14

Note

The VCR does not perform properly when the CTL/MENU switch is set to MENU position.

8-2-10 Operational Check-out (Continued)

3. Power the Video Cassette Recorder ON.
4. Press New Patient key when the PATIENT ENTRY MENU is displayed on the CRT monitor screen of LOGIQ™ 400.
5. Set the system so that the Video Cassette Recorder can work by the key operation on the console. The following steps (step a. to k.) indicates one example when you set the VCR control with the following conditions:

- I. Use S-Video cable for connecting between LOGIQ™ 400 and VCR.
- II. Connect RS232C cable with "port A" located at rear panel of LOGIQ™ 400.

- a. Press the Top Menu Select key located on the keyboard. The sub-menu selected previously is displayed on the CRT monitor screen.

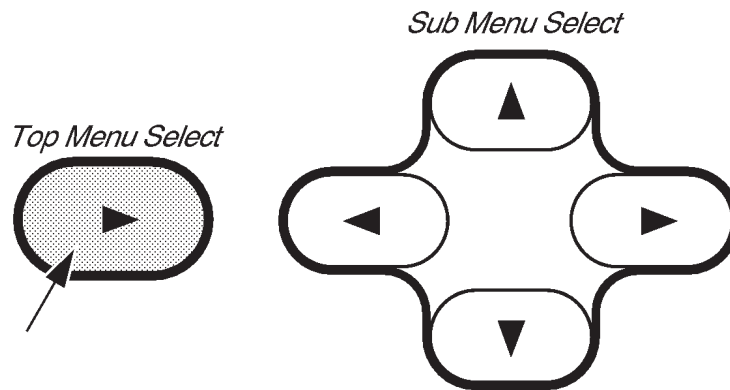

SOFTWARE MENU CONTROL KEYS
ILLUSTRATION 8-15

- b. Press the Top Menu Select key again. The top menu is displayed on CRT monitor screen as shown in ILLUSTRATION 8-16.

B	Preset	Set Up	ECG	Archive	AutoSeq	CINE
---	--------	---------------	-----	---------	---------	------

TOP MENU
ILLUSTRATION 8-16

- c. Select the Set Up Menu using the ◀ or ▶ key of Sub Menu Select keys. The Set Up selection is displayed in reverse video as shown in ILLUSTRATION 8-16.

8-2-10 Operational Check-out (Continued)

- d. Press **▼** key to select the Set Up Menu. The Set Up Menu is displayed on the CRT monitor screen as shown in ILLUSTRATION 8-17.

Set Up	1/1					
Custom Display	System Paramtr	Preset Program	Save Values	Utility	User Define	Diag.
▼▲	▼▲	▼▲	▼▲	▼▲	▼▲	▼▲

SET UP MENU
ILLUSTRATION 8-17

- e. Select the System Paramtr section using the **◀** or **▶** key of Sub Menu Select keys. The System Paramtr selection is displayed in reverse video as shown in ILLUSTRATION 8-17.
- f. Press **▼** key to select the System Parameter Set-Up Menu. The system parameter set-up menu is displayed on the CRT monitor screen as shown in ILLUSTRATION 8-18.

```

(Hospital Name)                                     26/07/95 18:45:02
USER PARAM SYSTEM PARA    PRESET PROG    CUSTOM DISP
PAGE      : 1/ 6          PRIOR    NEXT
COMMAND   : SAVE    RESET    DELETE    EXIT
***** System Setup *****
Hospital Name:
Date Format : YY/MM/DD MM/DD/YY DD/MM/Y
Time Format : 24H 12H
Language   : English French German Spanish Italian
Diag Category: Rad/Abd Obst Gyne Card Vasc Ural Smlpts
Report Cursor Blink : Off O
Report Cursor Type  : Underscore Block
CUA selection reset on New Patient : Of On
Insite Access Enable : Of On
Keyboard Tab        : Normal wor
Operation Error Beep : Off Of
Standby Time [min]  : 5 10 15 30 45 60 In
Power On Memory Test : Of On
Power On Status     : Keep-Latest Rese
System Error Erase Interval [min] : 0.1 1 10 In
CRT Menu Auto Erase Interval [sec] : 5 10 15 20 In
Display Probe Name  : Off O
    
```

Cursor

SYSTEM PARAMETER SET-UP MENU (1/6)
ILLUSTRATION 8-18

8-2-10 Operational Check-out (Continued)

- g. Move the cursor to "NEXT" position by rotating the trackball and press the Set button four times to display the fifth page (5/6).
- h. Move the cursor to "S-Video" position for the External Video Signal parameter and press **Set** key to select it. Refer to ILLUSTRATION 8-19.
- i. Move the cursor to "VCR" position for the Port A parameter and press **Set** key to select it. Refer to ILLUSTRATION 8-19.

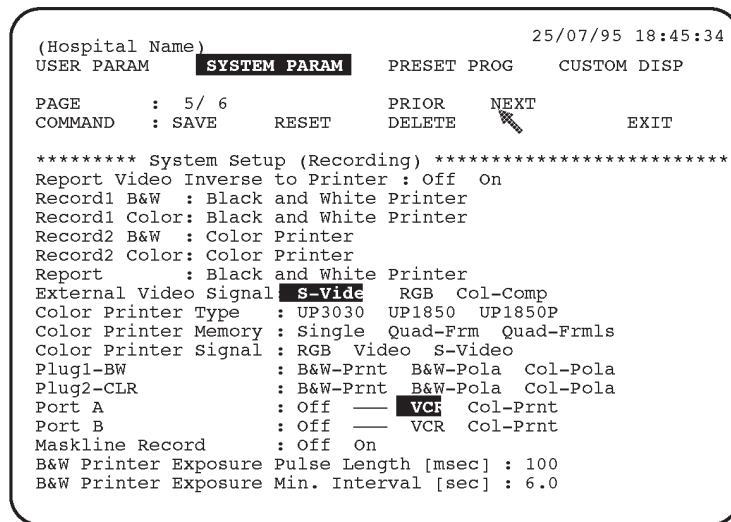

SYSTEM PARAMETER SET-UP MENU (5/6)

ILLUSTRATION 8-19

- j. Move the cursor to "SAVE" position and press Set button to save the selected parameters.
 - k. Press the Top Menu Select key twice to exit the System Parameter Set-Up menu.
6. Make sure that the Video Cassette Recorder is properly controlled by the console. For the VCR operation, refer to LOGIQ™ 400 User Manual.
 7. Perform leakage current test.
 8. Turn OFF the power switch of the main unit.

8-2-11 Final Procedures

1. Properly dispose of excess material.
2. This completes the installation of the Video Cassette Recorder.

8-2-12 Renewal Parts

ITEM	PART NAME	PART NO.	QTY.	DESCRIPTION
1	OPTION TRAY 1	2127115	1	used when installing VCR on console
2	OPTION TRAY 2	2127116	1	
3	VTR BASE	P9524JY	1	used when installing VCR on color monitor
4	VTR BELT	P9524JT	1	
5	STOPPER BLOCK	P9524HH	1	
6	PLATE	P9524JN	2	
7	CAUTION LABEL	P9524PU	1	
8	POWER CABLE ASSY	P9509EE	1	
9	RS232C CABLE ASSY	P9509MN	1	

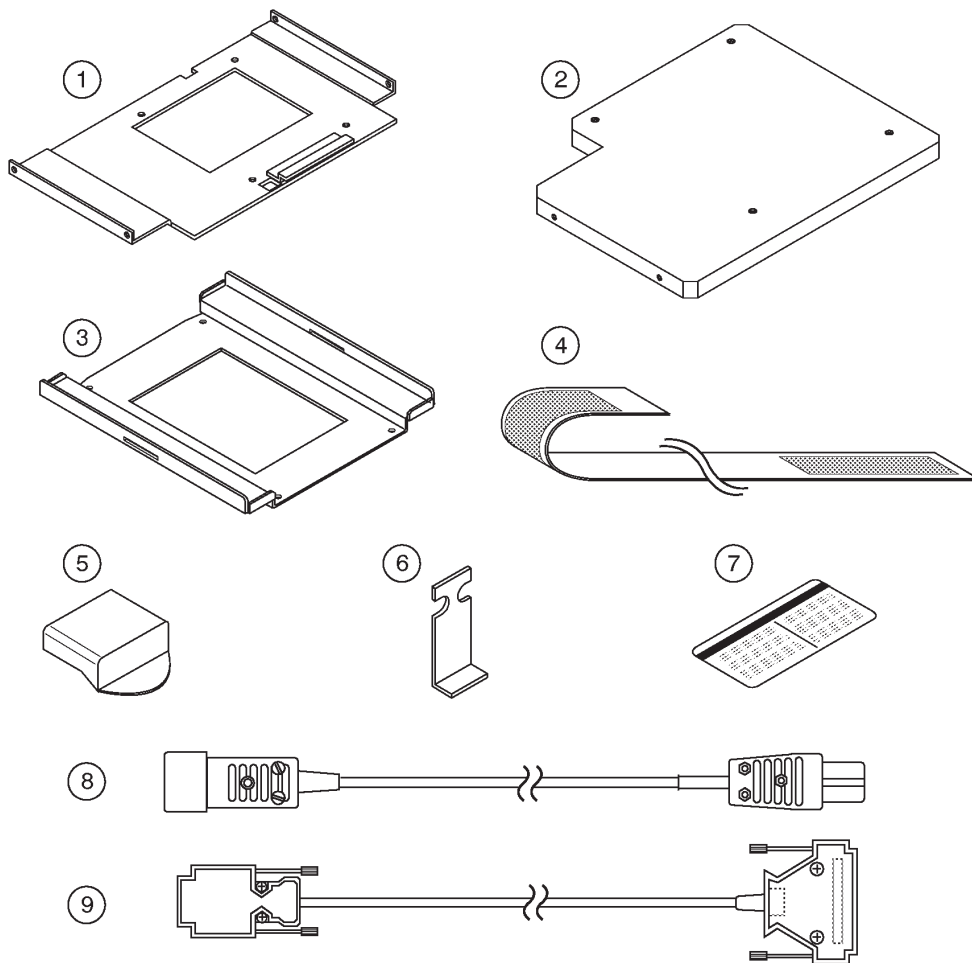

RENEWAL PARTS
ILLUSTRATION 8-20

8-3 COLOR VIDEO PRINTER INSTALLATION

8-3-1 Foreword

This section describes the installation of the following optional Color Video Printer for LOGIQ™ 400.

MANUFACTURER	MODEL	VIDEO SIGNAL
SONY	UP-1850MD	NTSC
SONY	UP-1850EPM	PAL
SONY	UP-2950MD	NTSC
SONY	UP-2850P	PAL
SONY	UP-2900MD	NTSC
SONY	UP-2800P	PAL

Note

We cannot control the Color Video Printers, UP-2950MD, UP-2850P, UP-2900MD, and UP-2800P from the LOGIQ™ 400 keyboard using the RS232C cable if the software version of the console is V3.30B or former (V3.20B or former for LOGIQ™ 400CL). In this case, we have to use those printers with connecting a mini plug cable to enable the LOGIQ™ 400 console to control only the print function. Other remote functions are not available in the case of the connection with the mini plug cable.

8-3-2 Tools Required

Standard field Service Tool kit.

8-3-3 Time Required

Approx. 1 hour

8-3-4 Parts Required

ITEM	PART NAME	QTY	PART #	REMARKS
1.	Color Video Printer	1	—	UP-1850MD, UP-2900MD, or UP-2950MD for NTSC UP-1850EPM, UP-2800P, or UP-2850P for PAL
2.	CP Front Assy	1	2127666	
	Option Tray 1	1	2127115	
	Option Tray 3	1	P9524ND	
	Tray	1	2127118	
	VTR Belt	1	P9524JT	
	Screw	12	—	
3.	Power Cable Assy	1	P9509EE	
4.	RS232C Cable Assy	1	P9509MN	

8-3-5 Functional Check-out

READ and UNDERSTAND these instructions thoroughly before proceeding with the installation. Perform each step in sequence and check it off when completed. If a problem occurs after completion, go back through the procedure and check for implementation errors before contacting your Ultrasound Region Engineer.



Possible operational damage. Failure to strictly follow ESD (Electrostatic Discharge) precautions during this upgrade may cause constant or intermittent operational abnormalities. Strictly follow all precautions.

Check each step as it is completed.

Perform functional checks to verify that the system is functioning properly. Refer to Chapter 4, Functional Checks.

8-3-6 Installing Color Video Printer on Console

1. Turn the system power OFF and unplug the unit. Follow the OSHA Lockout/Tagout Requirements (29 CFR 1910.147 Direction 46-015902).
2. Remove the Top Cover Sheet out of the system. Refer to ILLUSTRATION 8-21.
3. Raise the monitor up by pushing down the Up/down Release Button located on the Monitor Arm. Refer to ILLUSTRATION 8-21.

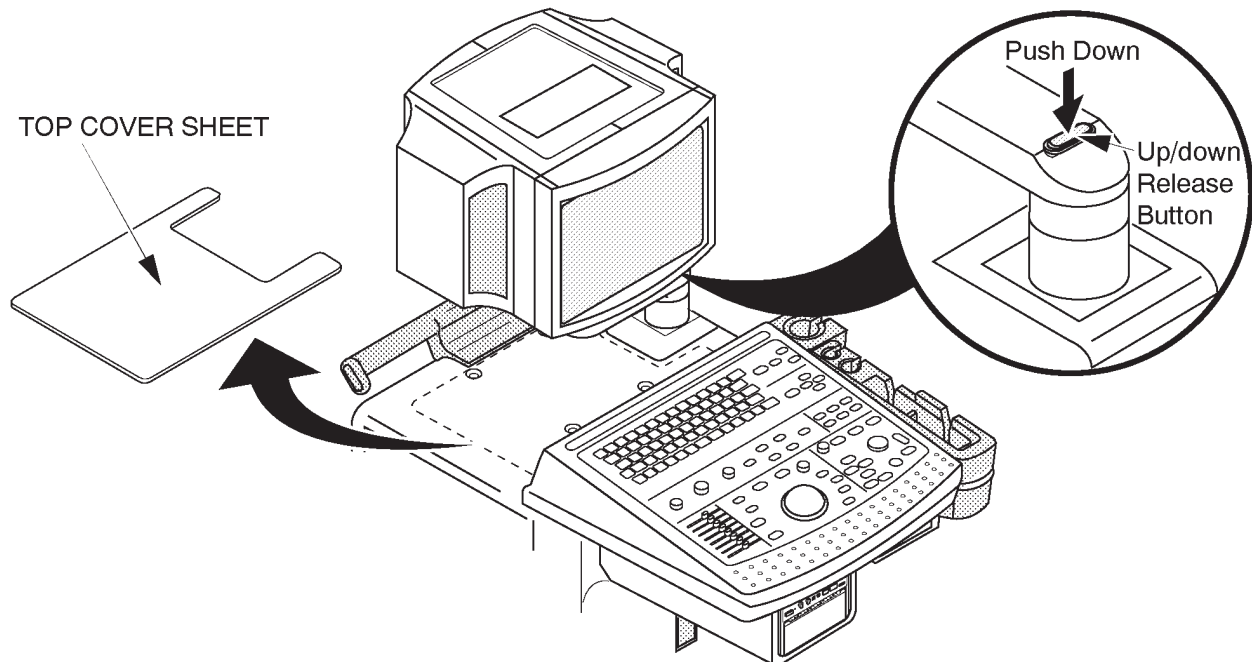

CONSOLE
ILLUSTRATION 8-21

8-3-6 Installing Color Video Printer on Console (Continued)

4. Put the OPTION TRAY 1 on the console and screw four screws supplied with CP FRONT ASSY (2127666) as shown in ILLUSTRATION 8-22.

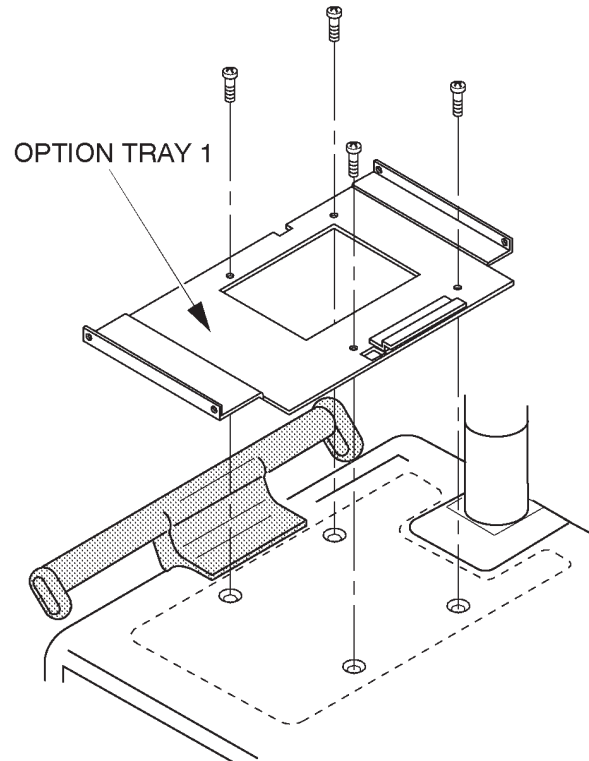

OPTION TRAY 1 INSTALLATION
ILLUSTRATION 8-22

8-3-6 Installing Color Video Printer on Console (Continued)

- 5. Set the TRAY on the OPTION TRAY 1 and screw four screws as shown in ILLUSTRATION 8-23.

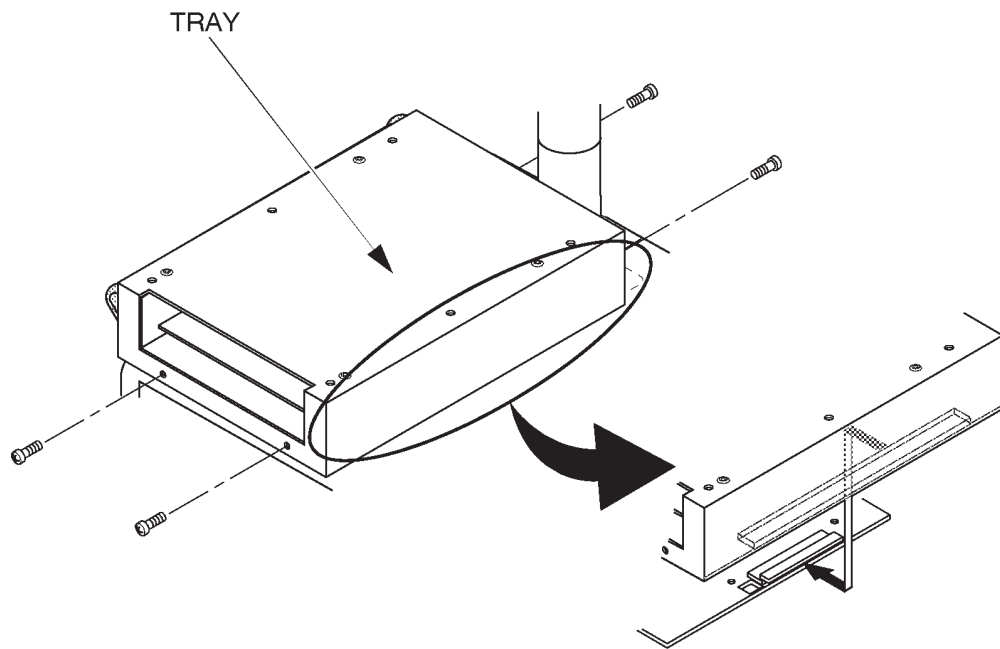

TRAY INSTALLATION
ILLUSTRATION 8-23

8-3-6 Installing Color Video Printer on Console (Continued)

- 6. Put the OPTION TRAY 3 on the TRAY and screw four screws as shown in ILLUSTRATION 8-24.

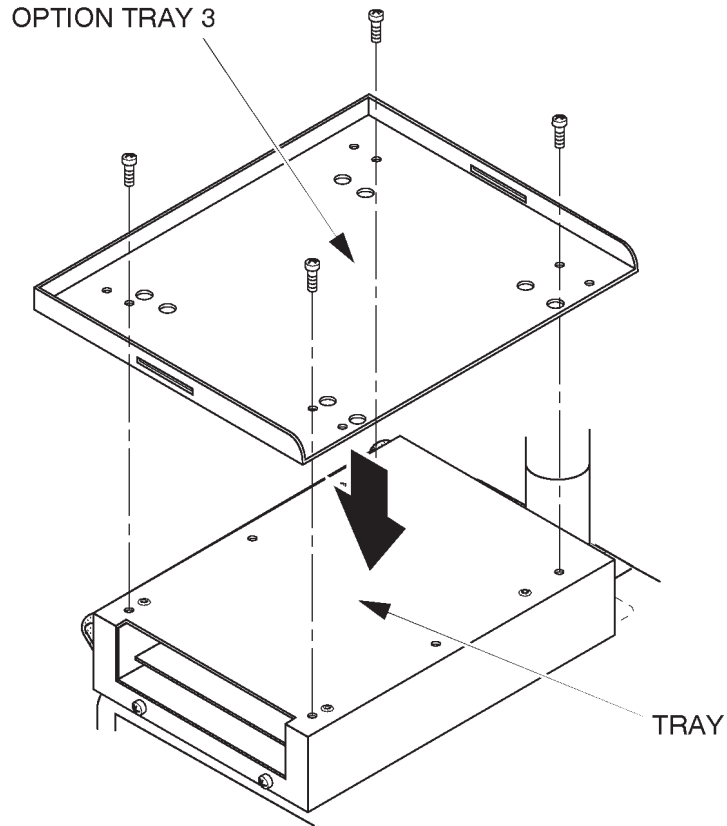

OPTION TRAY 3 INSTALLATION
ILLUSTRATION 8-24

8-3-6 Installing Color Video Printer on Console (Continued)

- 7. Pass the VTR BELT through the two slits of the OPTION TRAY 3 as shown in ILLUSTRATION 8-25.

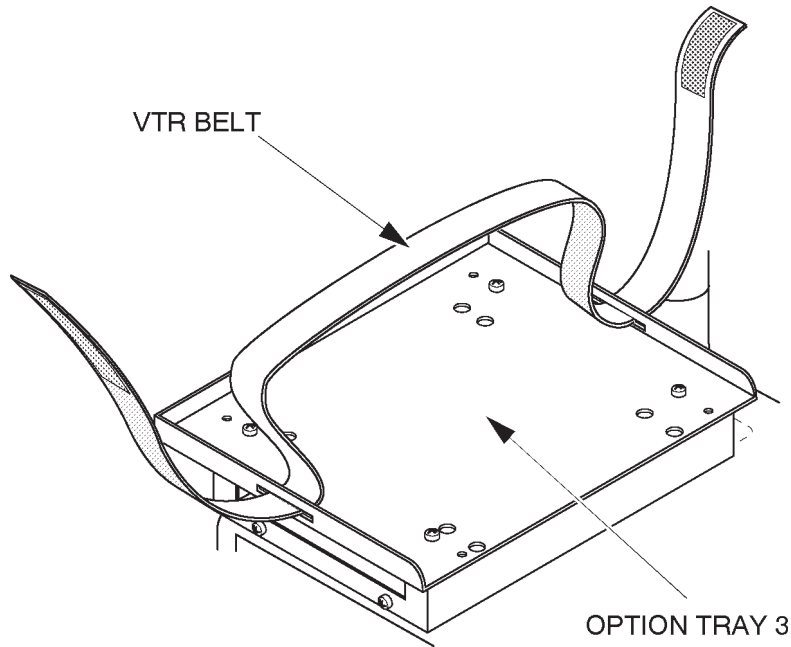

VTR BELT
ILLUSTRATION 8-25

- 8. Put the Color Video Printer onto the OPTION TRAY 3 and fix the Color Video Printer with the VTR BELT as shown in ILLUSTRATION 8-26.

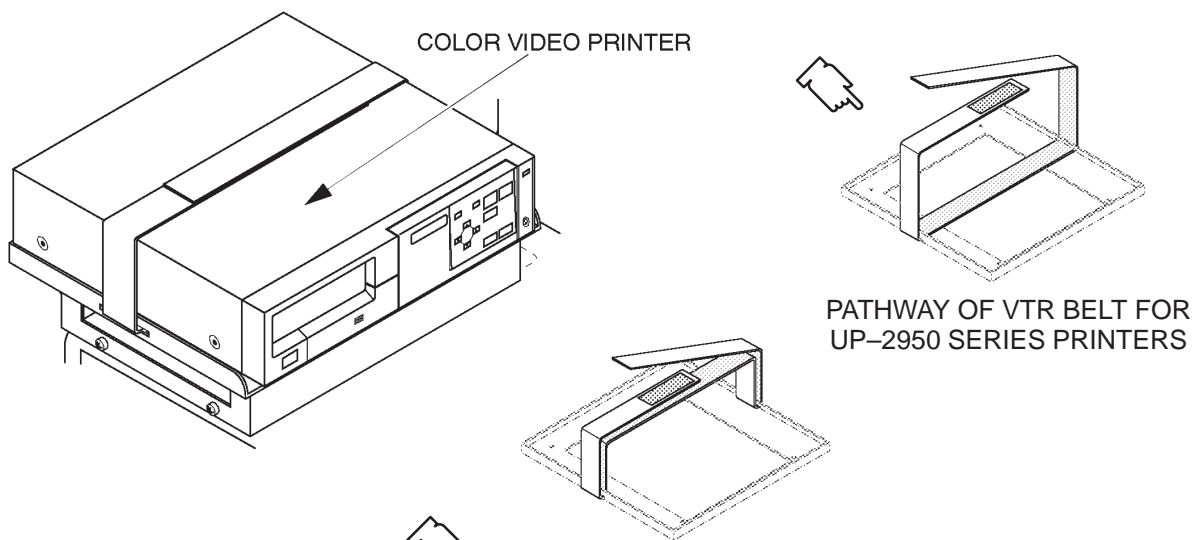

PATHWAY OF VTR BELT FOR UP-1850 SERIES PRINTERS

COLOR VIDEO PRINTER INSTALLATION
ILLUSTRATION 8-26

8-3-7 Connecting Cables

CAUTION

Use only the exclusive power cable to supply power to the peripheral recording devices from the LOGIQ™ 400. If a peripheral device is supplied power by other outlet, the system may be damaged by electrical noise transferred with the video signal or may not pass leakage current test.

1. Connect the power cable, RS232C cable, and the BNC video cables between the Color Video Printer and console as shown in ILLUSTRATION 8-27.

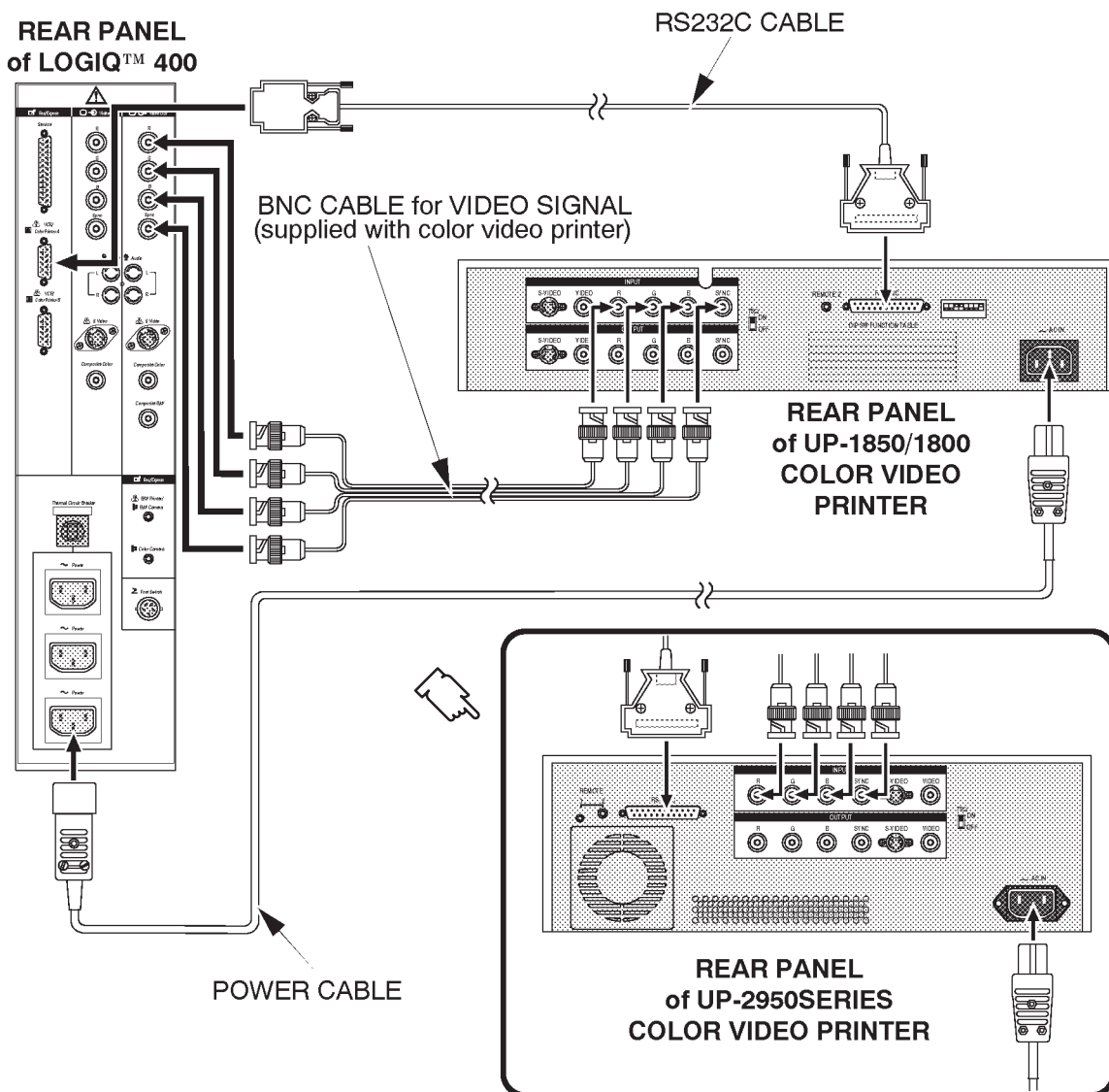

CONNECTING CABLES
ILLUSTRATION 8-27

8-3-7 Connecting Cables (Continued)

Note

The Color Video Printers, UP-2950MD, UP-2850P, UP-2900MD, and UP-2800P can be controlled from the LOGIQ™ 400 keyboard using the RS232C cable only for the MD console with the software version 3.30A or later and for the CL console with the software version 3.20A or later. For the console with the other software version, we have to use those printers with connecting a mini plug cable to enable the LOGIQ™ 400 console to control only the print function. Other remote functions are not available under this condition. For the connection of the mini plug cable, refer to ILLUSTRATION 8-28.

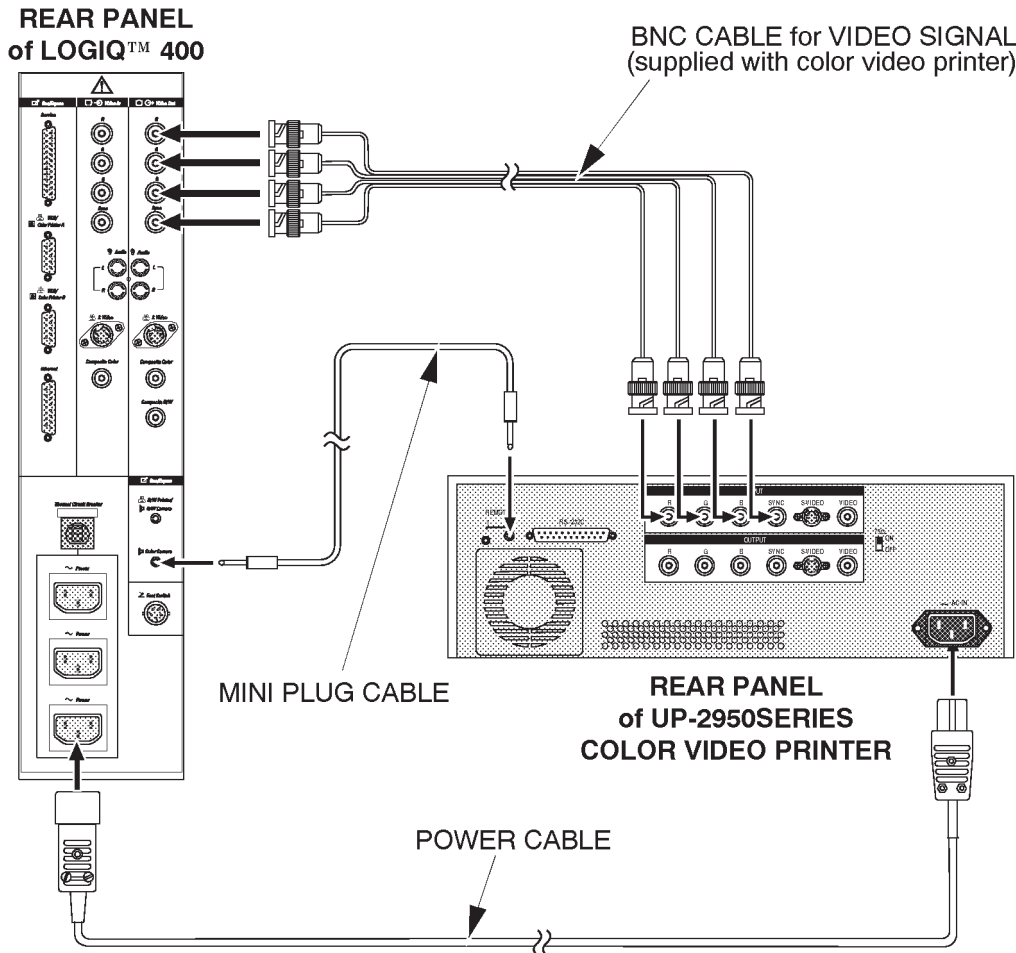

MINI PLUG CABLE CONNECTION WITH UP-2950 SERIES PRINTERS
ILLUSTRATION 8-28

8-3-8 Setting DIP Switches

1. Set the DIP switches located on the rear panel of the Color Video Printer as shown in ILLUSTRATION 8-29.

Note

The UP-2950MD series printers do not have the DIP switches. When you install those printers, you have to check and set the preset parameters of the printer. Follow the procedures in Section 8-3-9.

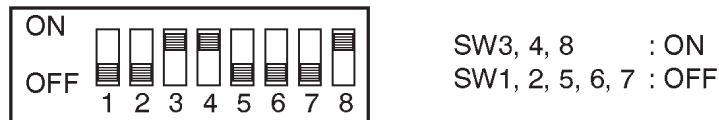

DIP SWITCH SETTINGS
ILLUSTRATION 8-29

8-3-9 Setting Parameters of UP-2950 Series Printers

This section provides the information for the required preset parameters of the UP-2950 series printers with the LOGIQ™ 400 console.

1. Plug in the system and power the system ON.
2. Power the Color Video Printer ON.
3. Open the Front Door of the UP-2950 MD or UP-2850P printer. Check and set some preset parameters using the control panel as shown in ILLUSTRATION 8-30.

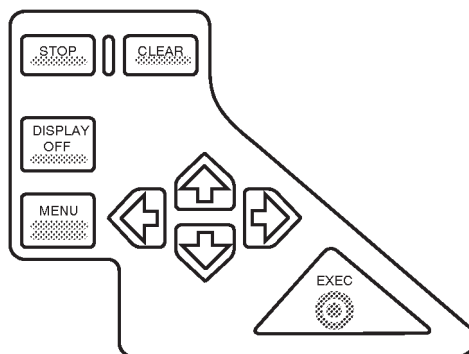

CONTROL PANEL OF UP-2950 SERIES COLOR PRINTER
ILLUSTRATION 8-30

8-3-9 Setting Parameters of UP-2950 Series Printers (Continued)

4. Press the MENU key. The COLOR SETUP top menu will be displayed on the LCD of the printer. Refer to ILLUSTRATION 8-31

COLOR SETUP
/COL/l/p/i/o/

SETUP MENU OF PRINTER (a)
ILLUSTRATION 8-31

Note

There are five (5) setup categories in the preset menu, COLOR (c), LAYOUT (l), PRINTER (p), INPUT (i), and OUTPUT (o). We can select the setup category on the Top menu of each category.

5. Press the RIGHT arrow key once to select the LAYOUT setup menu. Refer to ILLUSTRATION 8-32.

LAYOUT SETUP
/c/LAY/p/i/o/

SETUP MENU OF PRINTER (b)
ILLUSTRATION 8-32

6. Press the DOWN arrow key twice to display the "MULTI PIX" menu. Refer to ILLUSTRATION 8-33.

MULTI PIX :
-/--/--/4/--

SETUP MENU OF PRINTER (c)
ILLUSTRATION 8-33

7. Make sure that the "4" is selected for the MULTI. PIX ("--/--/4/--" is displayed on the LCD when the "4" is selected). Refer to ILLUSTRATION 8-33.
Otherwise, select the "4" using the LEFT arrow or RIGHT arrow key.
8. Press the DOWN arrow key once to display the "SEPARATE" menu. Refer to ILLUSTRATION 8-34.

SEPARATE :
OFF/on

SETUP MENU OF PRINTER (d)
ILLUSTRATION 8-34

9. Make sure that the SEPARATE is set to "OFF" ("OFF/on" is displayed on the LCD when the SEPARATE is set to OFF). Refer to ILLUSTRATION 8-34.
Otherwise, set the SEPARATE to "OFF" using the LEFT arrow or RIGHT arrow key.

8-3-9 Setting Parameters of UP-2950 Series Printers (Continued)

10. Press the UP arrow key three times to display the "LAYOUT SETUP" Top menu again. Refer to ILLUSTRATION 8-32.
11. Select the INPUT setup menu using the LEFT arrow or RIGHT arrow key ("/c//p/IN/o/" is displayed on the LCD when the INPUT setup menu is selected).
12. Press the DOWN arrow key once to display the "INPUT SEL" menu. Refer to ILLUSTRATION 8-35.

INPUT SEL : v / sv / RGB

SETUP MENU OF PRINTER (e)
ILLUSTRATION 8-35

13. Make sure that the "RGB" is selected ("v/sv/RGB" is displayed on the LCD when the RGB is selected). Refer to ILLUSTRATION 8-35. Otherwise, select the "RGB" using the LEFT arrow or RIGHT arrow key.
14. Press the UP arrow key once to display the "INPUT SETUP" Top menu.
15. Select the PRINTER setup menu using the LEFT arrow or RIGHT arrow key ("/c//PRN/i/o/" is displayed on the LCD when the PRINTER setup menu is selected).
16. Press the DOWN arrow key four times to display the "SYSTEM SETUP" menu. Refer to ILLUSTRATION 8-36.

SYSTEM SETUP : PRESS [>]
--

SETUP MENU OF PRINTER (f)
ILLUSTRATION 8-36

17. Press the RIGHT arrow key to display the SYSTEM SETUP sub-menu.
18. Press the DOWN arrow key twice to display the "BAUDRATE" menu. Refer to ILLUSTRATION 8-37.

BAUDRATE : 12 / 24 / 48 / 9600

SETUP MENU OF PRINTER (g)
ILLUSTRATION 8-37

19. Make sure that the "9600" is selected for the BAUDRATE ("12/24/48/9600" is displayed on the LCD when the 9600bps is selected). Refer to ILLUSTRATION 8-37. Otherwise, select the "9600" using the LEFT arrow or RIGHT arrow key.

8-3-9 Setting Parameters of UP-2950 Series Printers (Continued)

20. Press the UP arrow key twice and then the RIGHT arrow key once to display the "PRINTER SETUP" menu.
21. Press the DOWN arrow key five times to display the "FUNCTION SETUP" menu. Refer to ILLUSTRATION 8-38.



SETUP MENU OF PRINTER (h)
ILLUSTRATION 8-38

22. Press the RIGHT arrow key to display the FUNCTION SETUP sub-menu.
23. Press the DOWN arrow key twice to display the "IMMED. CAP" menu. Refer to ILLUSTRATION 8-39.



SETUP MENU OF PRINTER (i)
ILLUSTRATION 8-39

24. Make sure that the IMMED. CAP is set to "ON" ("off/ON" is displayed on the LCD when the IMMED. CAP is set to ON). Refer to ILLUSTRATION 8-39. Otherwise, set the IMMED. CAP to "ON" using the LEFT arrow or RIGHT arrow key.
25. Press the MENU key to exit the setup menu.

8-3-10 Operational Check-out

1. Plug in the system and power the system ON.
2. Power the Color Video Printer ON.
3. Press New Patient key when the PATIENT ENTRY MENU is displayed on the CRT monitor screen of LOGIQ™ 400.
4. Set the system so that the Color Video Printer can work by the key operation on the console. The following steps (step a. to o.) indicates one example when you set the Color Video Printer control with the following conditions:
 - I. Select UP-1850 color video printer.
 - II. Select Single memory as type of color printer memory.
 - III. Use RGB-Sync color printer signal.
 - IV. Connect RS232C cable with "port A" located at rear panel of LOGIQ™ 400.
 - V. Set that pressing Record1 key causes the color video printer to print image including color data. (Image including only B/W data is printed by B/W video printer.)

8-3-10 Operational Check-out (Continued)

Note

When installing the UP-3030 printer, the "UP3030" shall be selected for the Color Printer Type parameter on the SYSTEM PARAMETER SETUP menu.

Note

When installing the UP-2950MD or UP-2850P printer, the "UP1850" shall be selected for the Color Printer Type parameter on the SYSTEM PARAMETER SETUP menu.

- a. Press the Top Menu Select key located on the keyboard. The sub-menu selected previously is displayed on the CRT monitor screen.

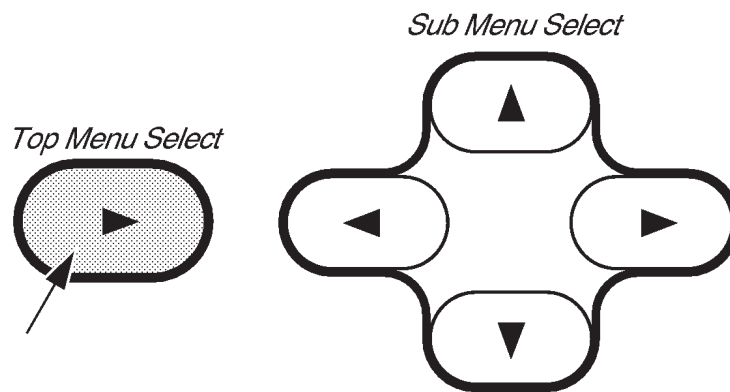

SOFTWARE MENU CONTROL KEYS
ILLUSTRATION 8-40

- b. Press the Top Menu Select key again. The top menu is displayed on CRT monitor screen as shown in ILLUSTRATION 8-41.

B	Preset	Set Up	ECG	Archive	AutoSeq	CINE
---	--------	---------------	-----	---------	---------	------

TOP MENU
ILLUSTRATION 8-41

- c. Select the Set Up Menu using the ◀ or ▶ key of Sub Menu Select keys. The Set Up selection is displayed in reverse video as shown in ILLUSTRATION 8-41.

8-3-10 Operational Check-out (Continued)

- d. Press **▼** key to select the Set Up Menu. The Set Up Menu is displayed on the CRT monitor screen as shown in ILLUSTRATION 8-42.

Set Up	1/1					
Custom Display	System Paramtr	Preset Program	Save Values	Utility	User Define	Diag.
▼▲	▼▲	▼▲	▼▲	▼▲	▼▲	▼▲

SET UP MENU
ILLUSTRATION 8-42

- e. Select the System Paramtr section using the **◀** or **▶** key of Sub Menu Select keys. The System Paramtr selection is displayed in reverse video as shown in ILLUSTRATION 8-42.
- f. Press **▼** key to select the System Parameter Set-Up Menu. The system parameter set-up menu is displayed on the CRT monitor screen as shown in ILLUSTRATION 8-43.

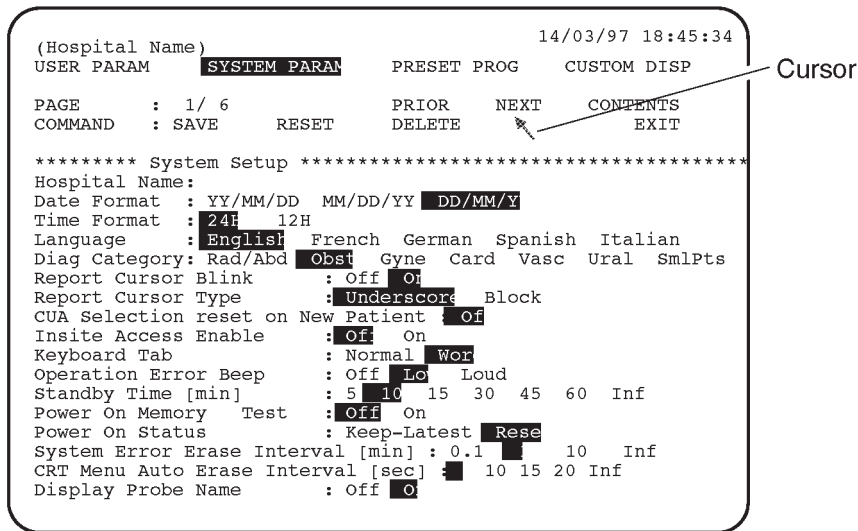

SYSTEM PARAMETER SET-UP MENU (1/6)
ILLUSTRATION 8-43

8-3-10 Operational Check-out (Continued)

- g. Move the cursor to "NEXT" position by rotating the trackball and press the Set button four times to display the fifth page (5/6).

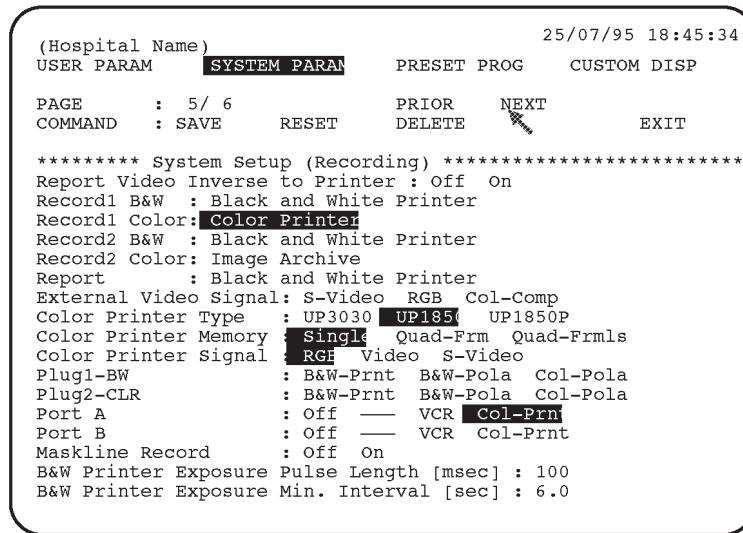

SYSTEM PARAMETER SET-UP MENU (5/6)

ILLUSTRATION 8-44

Note

The "Quaf-Frm" format is available only for the following color printers:

UP-1850MD, UP-1850EPM, UP-2950MD, and UP-2850P

The "Quaf-Frmls" selection for the Color Printer Memory in the SYSTEM PARAMETER SETUP, is not available for those printers. This function is valid only for the UP-3030MD printer.

- h. Select the "Black and White Printer" from among Record1 B&W parameters. Refer to ILLUSTRATION 8-44.
- i. Select the "Color Printer" from among Record1 Color parameters. Refer to ILLUSTRATION 8-44.

Note

Use Ellipse keys to select the Record1 and Record2 parameters. Other option is displayed by pressing the Ellipse keys when the current selection of Record1 parameter or Record2 parameter is displayed in reverse video.

- j. Move the cursor to "UP1850" for the Color Printer Type parameter and press **Set** to select it. Refer to ILLUSTRATION 8-44.
- k. Move the cursor to "Single" for the Color Printer Memory parameter and press **Set** to select it. Refer to ILLUSTRATION 8-44.
- l. Move the cursor to "RGB" for the Color Printer Signal parameter and press **Set** to select it. Refer to ILLUSTRATION 8-44.

8-3-10 Operational Check-out (Continued)

- m. Move the cursor to "Col-Prnt" for the Port A parameter and press **Set** to select it. Refer to ILLUSTRATION 8-44.

Note

If you install the UP-2950 series printer on the LOGIQ™ 400 console with the version 3.30 or older for MD console (3.20 or older for CL console) and connect the mini plug cable between the Plug-2 jack of the LOGIQ™ 400 console and the Remote-2 jack of the printer, select the "Color poraloid camera" from among the Record1 Color parameter and the "Col-Pola" from among the Plug-2 parameter.

- n. Move the cursor to "SAVE" position and press Set button to save the selected parameters.
 - o. Press the Top Menu Select key twice to exit the System Parameter Set-Up menu.
5. Make sure that the Color Video Printer is properly controlled by the console.

Note

If the UP-2950 series printer is connected with the LOGIQ™ 400 console using the mini plug cable, only the print function can be controlled from the keyboard operation.

6. Perform leakage current test.
7. Turn OFF the power switch of the main unit.

8-3-11 Final Procedures

1. Properly dispose of excess material.
2. This completes the installation of the Color Video Printer.

8-3-12 Renewal Parts

ITEM	PART NAME	PART NO.	QTY.	DESCRIPTION
1	OPTION TRAY 1	2127115	1	
2	OPTION TRAY 3	P9524ND	1	
3	TRAY	2127118	1	
4	VTR BELT	P9524JT	1	
5	POWER CABLE ASSY	P9509EE	1	
6	RS232C CABLE ASSY	P9509MN	1	

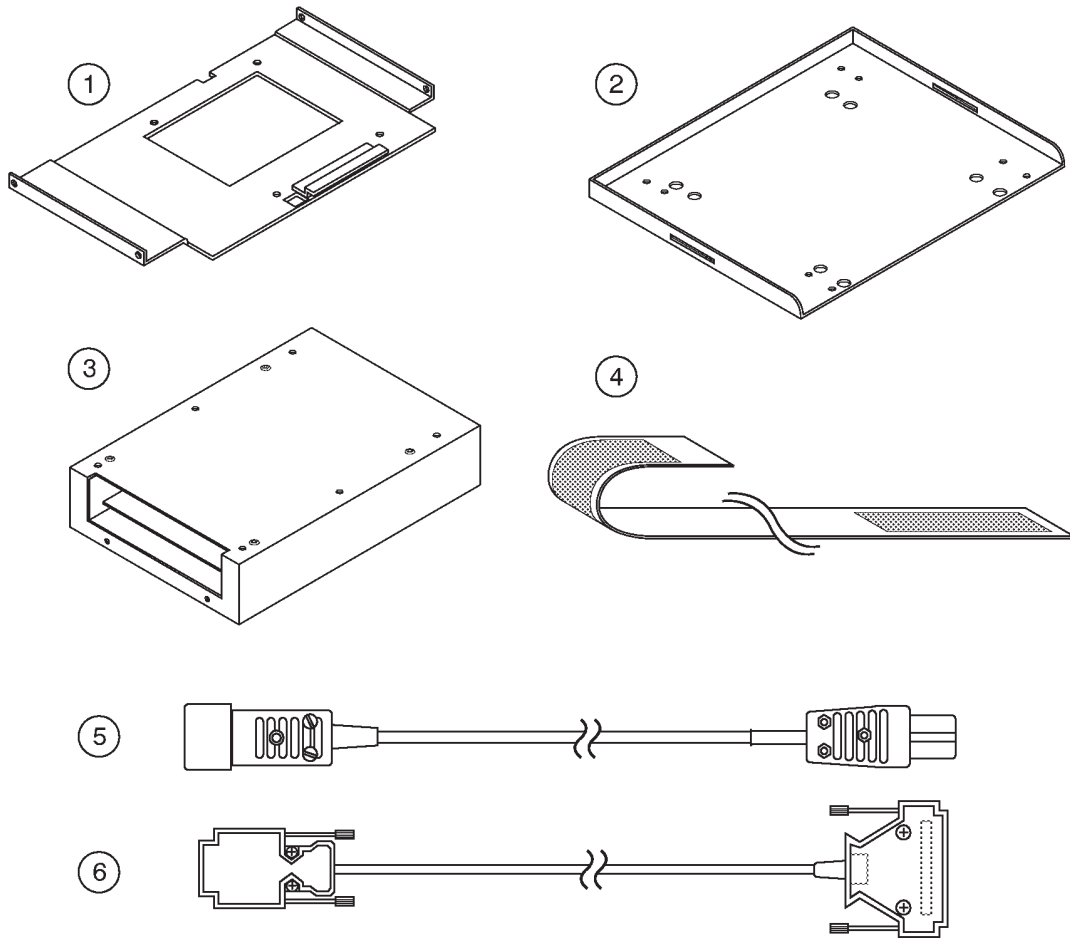

RENEWAL PARTS
ILLUSTRATION 8-45

8-4 B/W PRINTER INSTALLATION

8-4-1 Foreword

This section describes for the installation of the optional Sony UP-890 B/W Video Printer LOGIQ™ 400.

8-4-2 Tools Required

Standard field Service Tool kit.

8-4-3 Time Required

Approx. 45 Minutes

8-4-4 Parts Required

ITEM	PART NAME	QTY	PART #	REMARKS
1.	B/W Video Printer	1	—	Sony UP-890 B/W video printer is shipped separately
2.	B/W Printer Assy	1	P9522XG	
	Printer PL	1	P9524BZ	
	Screw	4	—	
	Screw	2	—	
3.	Power Cable Assy	1	P9509LH	
4.	Mini Plug Cable	1	P9509BC	

8-4-5 Functional Check-out

READ and UNDERSTAND these instructions thoroughly before proceeding with the installation. Perform each step in sequence and check it off when completed. If a problem occurs after completion, go back through the procedure and check for implementation errors before contacting your Ultrasound Region Engineer.



Possible operational damage. Failure to strictly follow ESD (Electrostatic Discharge) precautions during this upgrade may cause constant or intermittent operational abnormalities. Strictly follow all precautions.

Check each step as it is completed.

Perform functional checks to verify that the system is functioning properly. Refer to Chapter 4, Functional Checks.

8-4-6 Setting DIP Switches

1. Make sure that the DIP switches located on the rear panel of the B/W Video Printer are set as shown in ILLUSTRATION 8-46. Refer to the Sony B/W Video Printer operator manual.



DIP SWITCH SETTINGS
ILLUSTRATION 8-46

8-4-7 Installing B/W Video Printer on Console

1. Turn the system power OFF and unplug the unit. Follow the OSHA Lockout/Tagout Requirements (29 CFR 1910.147, Direction 46-015902).
2. Unscrew four screws fixing the rubber feet of the B/W Video Printer as shown in ILLUSTRATION 8-47.

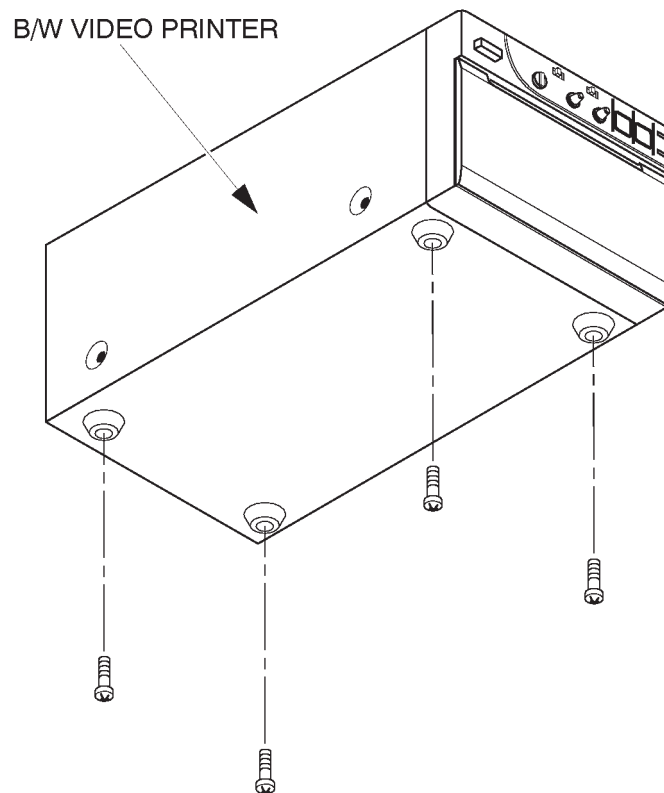

B/W VIDEO PRINTER
ILLUSTRATION 8-47

8-4-7 Installing B/W Video Printer on Console (Continued)

- 3. Screw four screws supplied with the B/W Printer Assy to install the Printer PL to the B/W Video Printer. Refer to ILLUSTRATION 8-48.

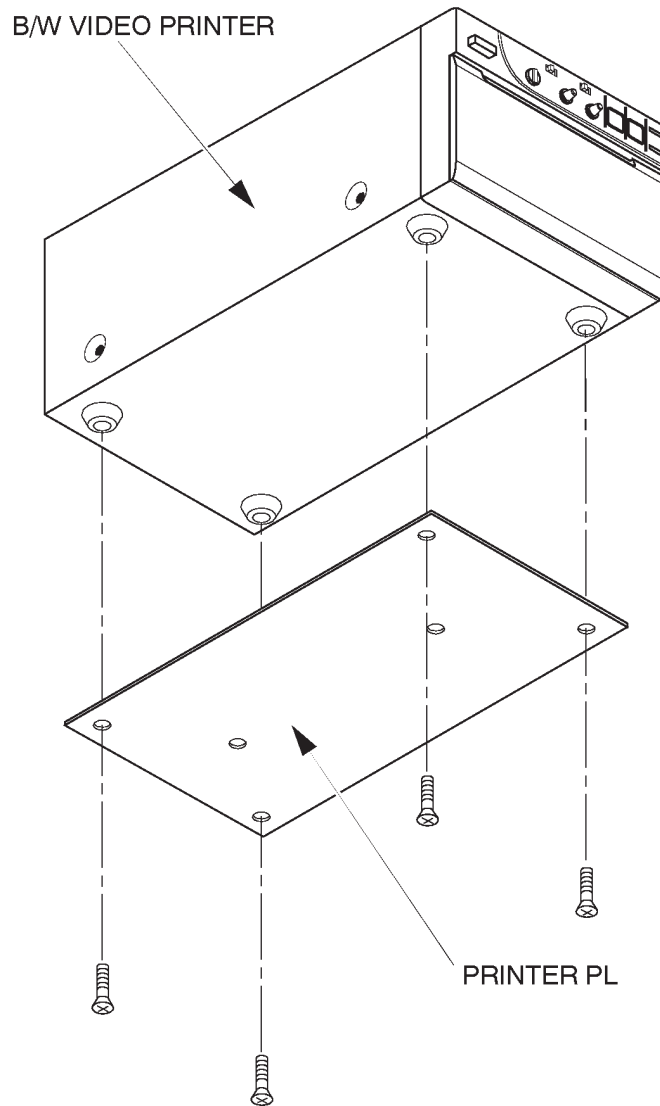

PRINTER PL INSTALLATION
ILLUSTRATION 8-48

8-4-7 Installing B/W Video Printer on Console (Continued)

4. Connect three cables, the power cable, BNC-BNC cable, and the mini plug cable, between the front CONN panel of the console and the rear panel of the B/W Video Printer. Refer to 8-4-8, Connecting Cables.

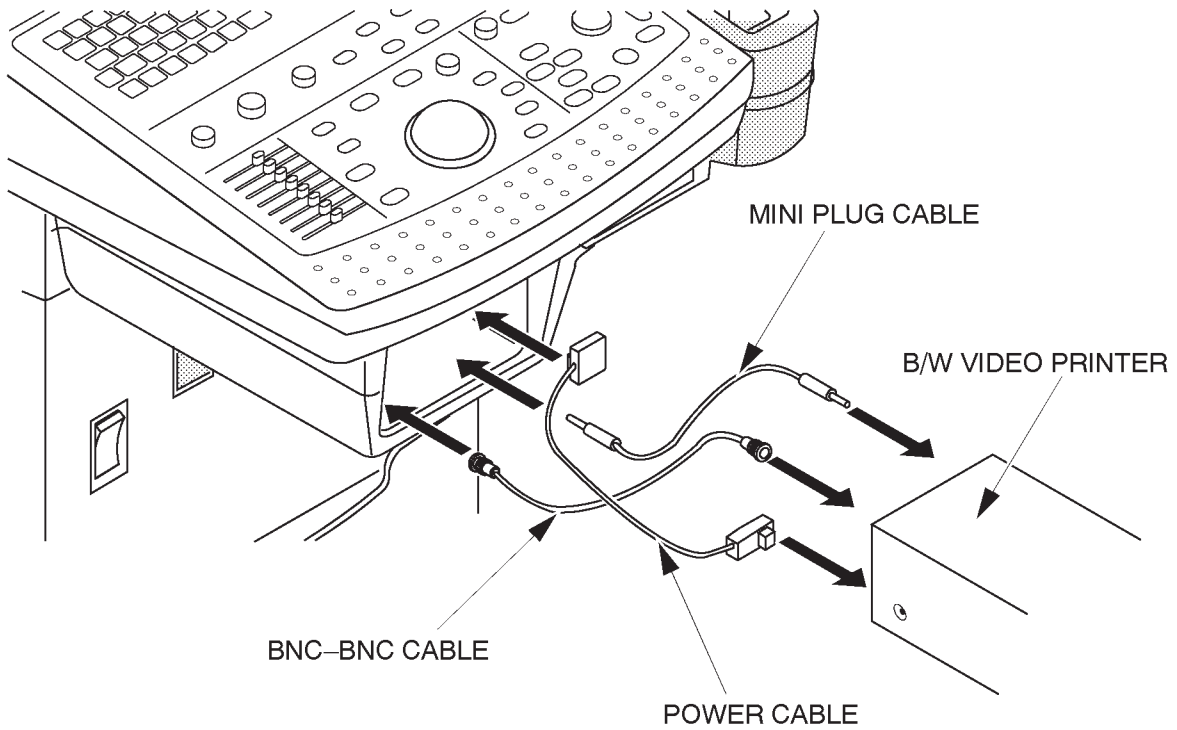

CONNECTING CABLES
ILLUSTRATION 8-49



8-4-7 Installing B/W Video Printer on Console (Continued)

5. Insert the B/W Video Printer with the Printer PL into the Printer Tray as shown in ILLUSTRATION 8-50.
6. Screw two screws as shown in ILLUSTRATION 8-50.

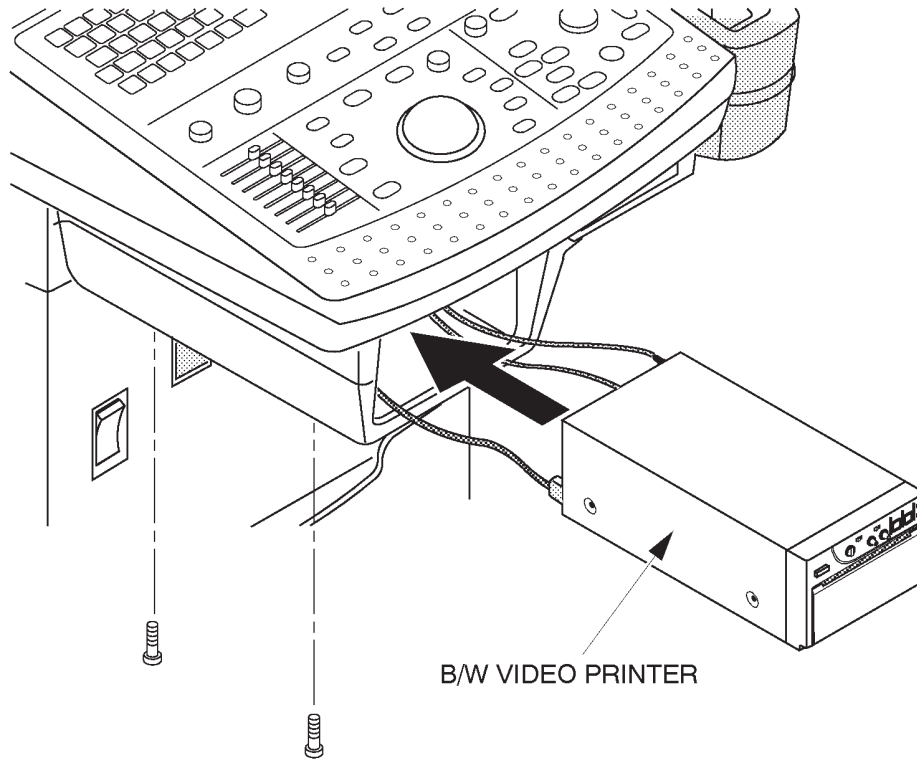

B/W VIDEO PRINTER INSTALLATION
ILLUSTRATION 8-50

8-4-8 Connecting Cables

CAUTION

Use only the exclusive power cable to supply power to the peripheral recording devices from the LOGIQ™ 400. If a peripheral device is supplied power by other outlet, the system may be damaged by electrical noise transferred with the video signal or may not pass leakage current test.

1. Connect the power cable, mini plug cable, and the BNC-BNC cable between the B/W Video Printer and the console as shown in ILLUSTRATION 8-51.

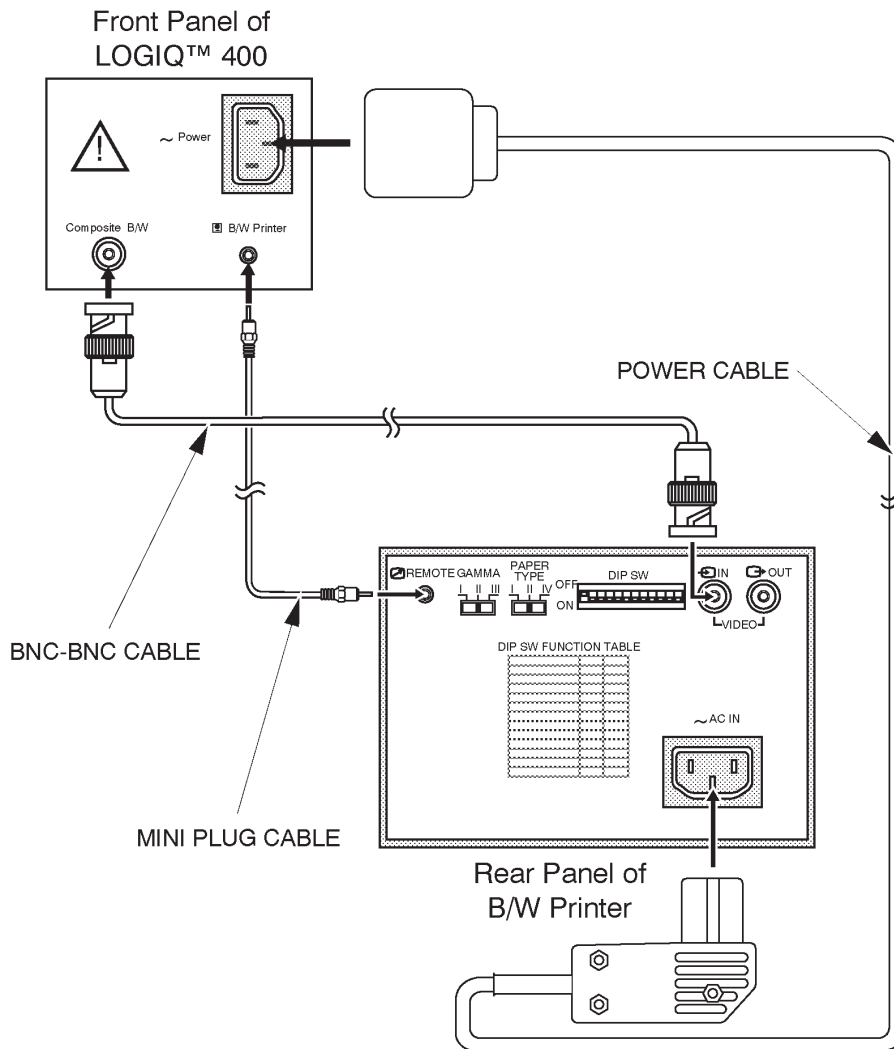

CABLE CONNECTION
ILLUSTRATION 8-51

8-4-9 Operational Check-out

1. Plug in the system and power the system ON.
2. Power the B/W Video Printer ON.
3. Press New Patient key when the PATIENT ENTRY MENU is displayed on the CRT monitor screen of LOGIQ™ 400.
4. Set the system so that the B/W Video Printer can work by the key operation on the console.
The following steps (step a. to m.) indicates one example when you set the B/W Video Printer control with the conditions below:

- I. Connect Mini Plug cable with Plug 1 "B/W Printer" located at front panel of LOGIQ™ 400. Refer to ILLUSTRATION 8-51.
- II. Set that pressing Record1 key causes the B/W video printer to print image including only B/W data. (Image including color data is printed by color video printer.)
- III. Select B/W printer for printing report page.
- IV. Select inverse print for printing report page.

- a. Press the Top Menu Select key located on the keyboard. The sub-menu selected previously is displayed on the CRT monitor screen.

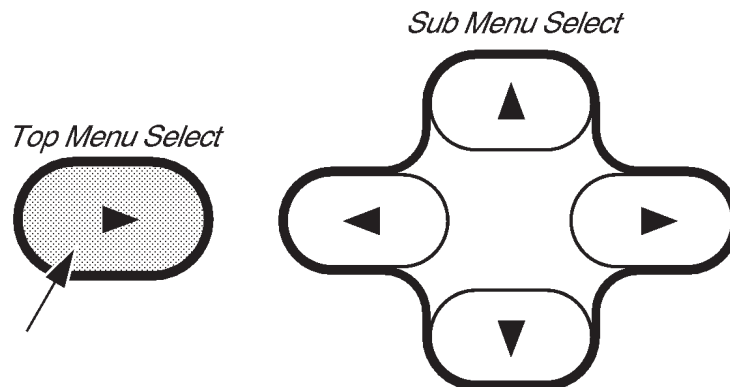

SOFTWARE MENU CONTROL KEYS
ILLUSTRATION 8-52

- b. Press the Top Menu Select key again. The top menu is displayed on CRT monitor screen as shown in ILLUSTRATION 8-53.



TOP MENU
ILLUSTRATION 8-53

- c. Select the Set Up Menu using the ◀ or ▶ key of Sub Menu Select keys. The Set Up selection is displayed in reverse video as shown in ILLUSTRATION 8-53.

8-4-9 Operational Check-out (Continued)

- d. Press **▼** key to select the Set Up Menu. The Set Up Menu is displayed on the CRT monitor screen as shown in ILLUSTRATION 8-54.

Set Up	1/1					
Custom Display	System Paramtr	Preset Program	Save Values	Utility	User Define	Diag.
▼▲	▼▲	▼▲	▼▲	▼▲	▼▲	▼▲

SET UP MENU
ILLUSTRATION 8-54

- e. Select the System Paramtr section using the **◀** or **▶** key of Sub Menu Select keys. The System Paramtr selection is displayed in reverse video as shown in ILLUSTRATION 8-54.
- f. Press **▼** key to select the System Parameter Set-Up Menu. The system parameter set-up menu is displayed on the CRT monitor screen as shown in ILLUSTRATION 8-55.

```

(Hospital Name)                               14/03/97 18:45:34
USER PARAM  SYSTEM PARAM  PRESET PROG  CUSTOM DISP
PAGE       : 1/ 6      PRIOR  NEXT  CONTENTS
COMMAND    : SAVE     RESET  DELETE  EXIT
***** System Setup *****
Hospital Name:
Date Format  : YY/MM/DD  MM/DD/YY  DD/MM/Y
Time Format  : 24H   12H
Language    : English  French German Spanish Italian
Diag Category: Rad/Abd  Obst  Gyne  Card  Vasc  Ural  SmlPts
Report Cursor Blink : Off  On
Report Cursor Type  : Underscore  Block
CUA Selection reset on New Patient : Of
Insite Access Enable : Of  On
Keyboard Tab        : Normal  Wor
Operation Error Beep : Off  Lo  Loud
Standby Time [min]  : 5  10  15  30  45  60  Inf
Power On Memory Test : Off  On
Power On Status     : Keep-Latest  Rese
System Error Erase Interval [min] : 0.1  10  Inf
CRT Menu Auto Erase Interval [sec] :  10  15  20  Inf
Display Probe Name  : Off  O
    
```

Cursor

SYSTEM PARAMETER SET-UP MENU (1/6)
ILLUSTRATION 8-55

8-4-9 Operational Check-out (Continued)

- g. Move the cursor to "NEXT" position by rotating the trackball and press the Set button four times to display the fifth page (5/6).

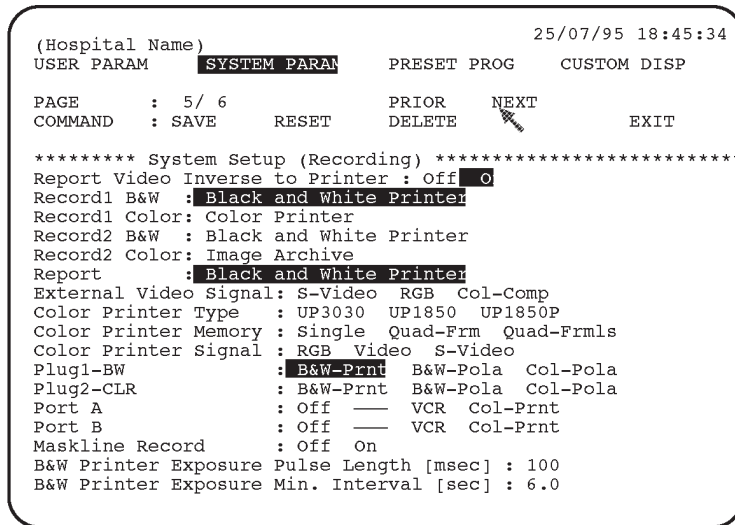

SYSTEM PARAMETER SET-UP MENU (5/6)
ILLUSTRATION 8-56

- h. Move the cursor to "On" for the "Report Video Inverse to Printer" parameter and press **Set** to select it. Refer to ILLUSTRATION 8-56.
- i. Select "B&W-Prnt" from among Record1 B/W parameters. Refer to ILLUSTRATION 8-56.

Note

Use Ellipse keys to select the Record1 and Record2 parameters. Other option is displayed by pressing the Ellipse keys when the current selection of Record1 parameter or Record2 parameter is displayed in reverse video.

- j. Move the cursor to "B&W-Prnt" for the Report parameter and press **Set** to select it. Refer to ILLUSTRATION 8-56.
- k. Move the cursor to "B&W-Prnt" for the Plug1-BW parameter and press **Set** to select it. Refer to ILLUSTRATION 8-56.
- l. Move the cursor to "SAVE" position and press **Set** to save the selected parameters.
- m. Press the **Top Menu Select** key twice to exit the System Parameter Set-Up menu.

- 5. Make sure that the B/W Video Printer is properly controlled by the console.
- 6. Perform leakage current test.
- 7. Turn OFF the power switch of the main unit.

8-4-10 Final Procedures

1. Properly dispose of excess material.
2. This completes the installation of the B/W Video Printer.

8-4-11 Renewal Parts

ITEM	PART NAME	PART NO.	QTY.	DESCRIPTION
1	PRINTER PL	P9524BZ	1	
2	POWER CABLE	P9509LH	1	
3	MINI PLUG CABLE	P9509BC	1	

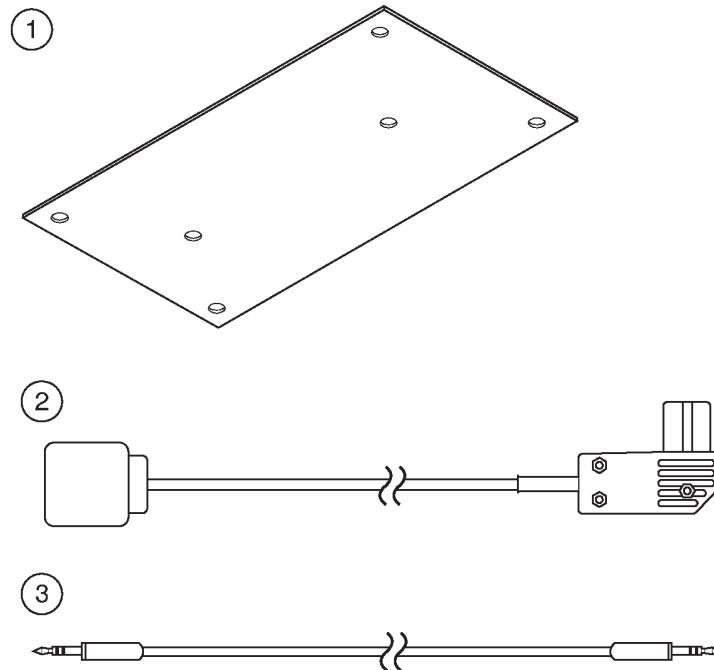

RENEWAL PARTS
ILLUSTRATION 8-57



8-5 ECG OPTION INSTALLATION

8-5-1 Foreword

This section describes the installation of the ECG option for LOGIQ™ 400.

8-5-2 Tools Required

Standard field Service Tool kit

8-5-3 Time Required

Approx. 1 Hour

8-5-4 Parts Required

ITEM	PART NAME	QTY	PART #	REMARKS
1.	ECG Assy	1	P9522WY	
	ECG Board Assy	1	P9522WZ	includes screws for mounting on console ECG Board Assy (P9522WZ) can be replaced with ECG Board2 Assy (2207806)
	or ECG Board2 Assy	1	2207806	
	CONN Panel Assy	1	P9522XB	
	Caution Label	1	P9524PS	
	Option Label	1	—	
2.	ECG Cable Assy	1	P9509KG	For Japan
	ECG Cable (system side)	1	P9509KC	
	ECG Cable (patient side)	1	P9509KD	
2.	ECG Cable Assy	1	P9509KH	For USA, Europe and others
	ECG Cable (system side)	1	P9509KE	
	ECG Cable (patient side)	1	P9509KF	
3.	PCG sensor	1	P9509KN	

8-5-5 Functional Check-out

READ and UNDERSTAND these instructions thoroughly before proceeding with the installation. Perform each step in sequence and check it off when completed. If a problem occurs after completion, go back through the procedure and check for implementation errors before contacting your Ultrasound Region Engineer.



Possible operational damage. Failure to strictly follow ESD (Electrostatic Discharge) precautions during this upgrade may cause constant or intermittent operational abnormalities. Strictly follow all precautions.

Check each step as it is completed.

Perform functional checks to verify that the system is functioning properly. Refer to Chapter 4, Functional Checks.

8-5-6 Installing ECG Board Assy

1. Turn the system power OFF and unplug the unit. Follow the OSHA Lockout/Tagout Requirements (29 CFR 1910.147, Direction 46-015902).
2. Remove the Side Cover Right. Refer to 6-2-27 in Chapter 6, Renewal Parts.
3. Unscrew four screws (① – ④) and remove the CONN panel 2.

Note

Keep removed screws because they are required to mount the ECG panel assy onto console.

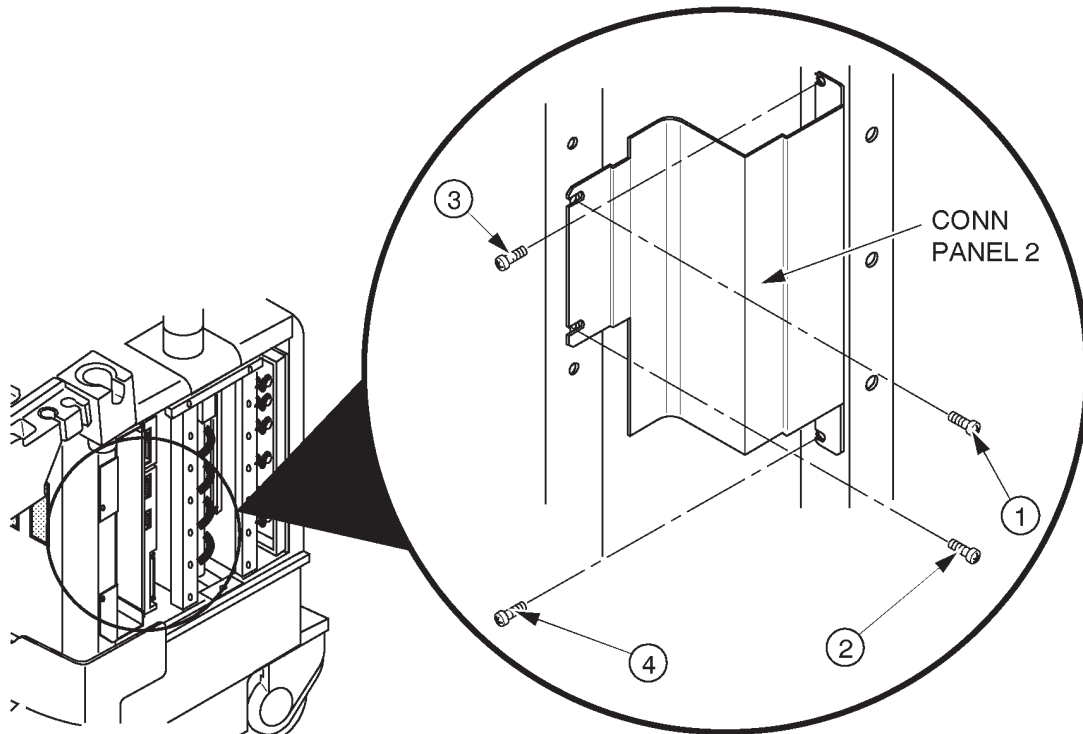

CONN PANEL 2 REMOVAL
ILLUSTRATION 8-58



8-5-6 Installing ECG Board Assy (Continued)

- 4. Install the ECG Board Assy by screwing two screws (2) and (3) as shown in ILLUSTRATION 8-59.
- 5. Connect the cable (1): CB22) from the Mother Board with the connector on the ECG board assy. Refer to ILLUSTRATION 8-59.

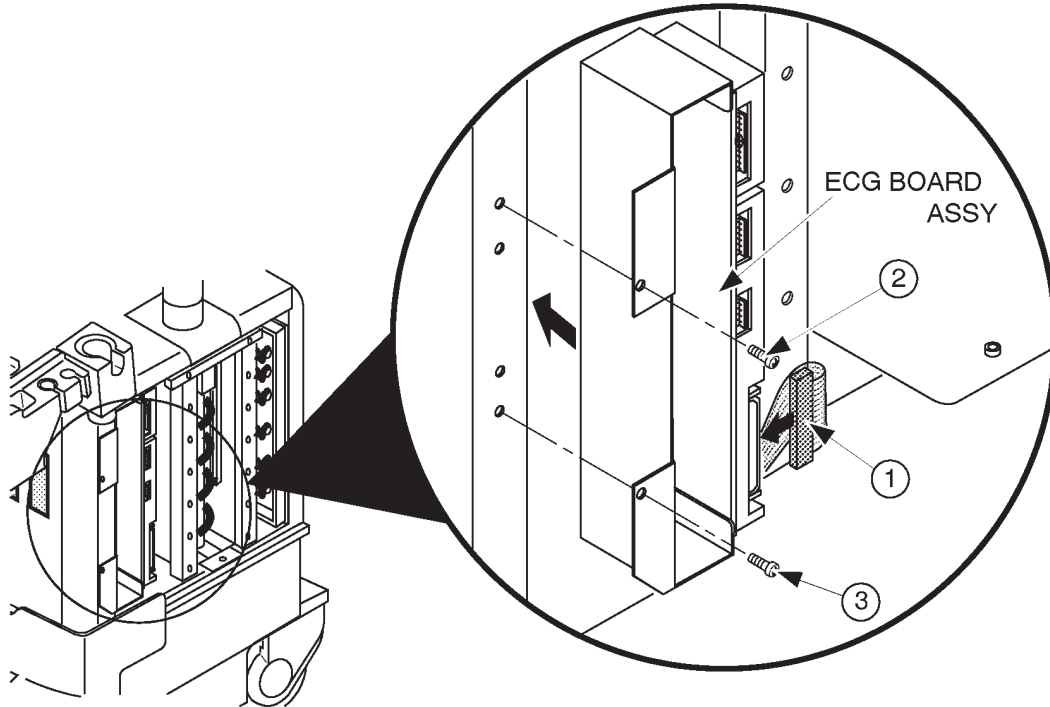

ECG BOARD ASSY INSTALLATION
ILLUSTRATION 8-59

8-5-7 Installing ECG Panel Assy

1. Connect three cables (①–③) on the ECG panel assy with the ECG board assy. Refer to ILLUSTRATION 8-60.

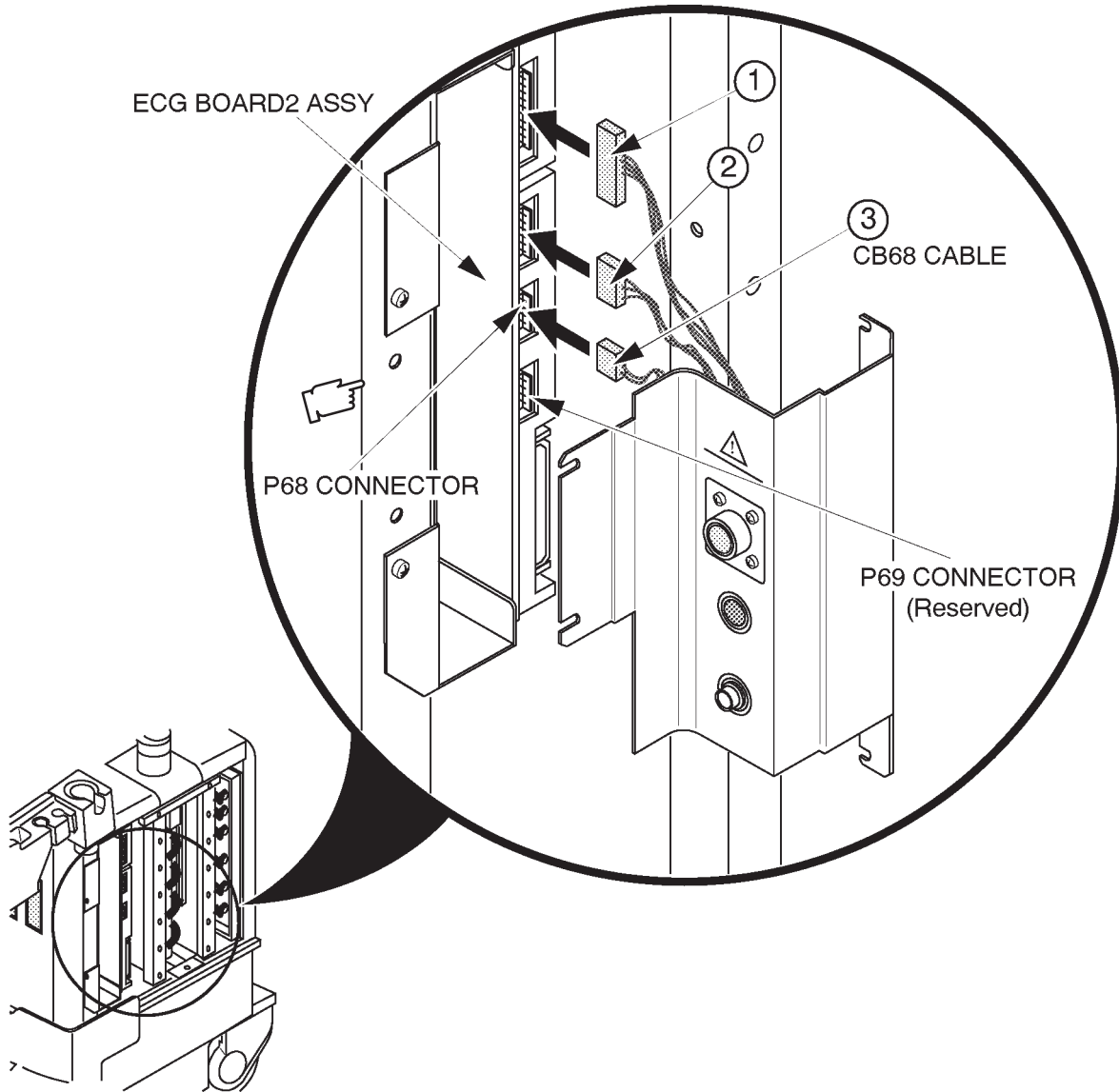

CONNECTING CABLES
ILLUSTRATION 8-60

Note

The additional 4-pin connector (P69) is supplied with the ECG Board2 Assy for the reserved function. Be sure to plug the CB68 cable for the AUX to the P68 connector on the ECG Board2 Assy. Otherwise, the Auxiliary function shall not be functioning properly.

8-5-7 Installing ECG Panel Assy (Continued)

- 2. Screw four screws (1) – (4) to install the ECG panel assy as shown in ILLUSTRATION 8-61.

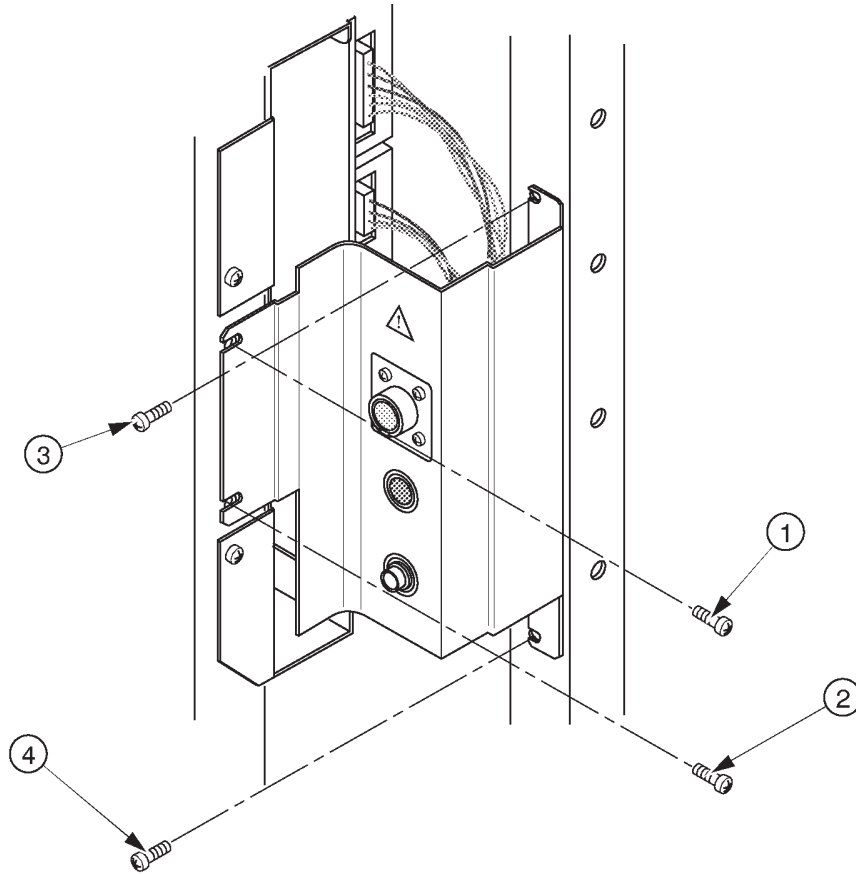

INSTALLING ECG PANEL ASSY
ILLUSTRATION 8-61

- 3. Re-install the Side Cover Right.

8-5-8 Operational Check-out

1. Connect the ECG patient cable with the connector on the ECG panel as shown in ILLUSTRATION 8-62.

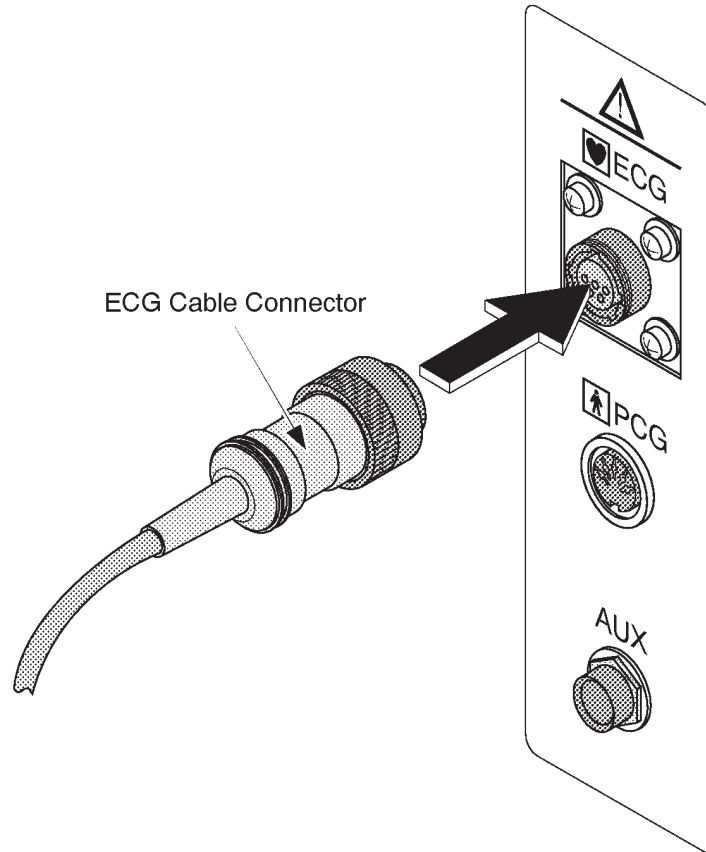

CONNECTING ECG PATIENT CABLE
ILLUSTRATION 8-62

2. Connect the electrodes of ECG patient cable with the ECG simulator.
3. Plug in the system and turn the system power ON.

8-5-8 Operational Check-out (Continued)

4. Display the single B-mode image.
5. Press the Top Menu Select key located on the keyboard. The sub-menu selected previously is displayed on the CRT monitor screen.

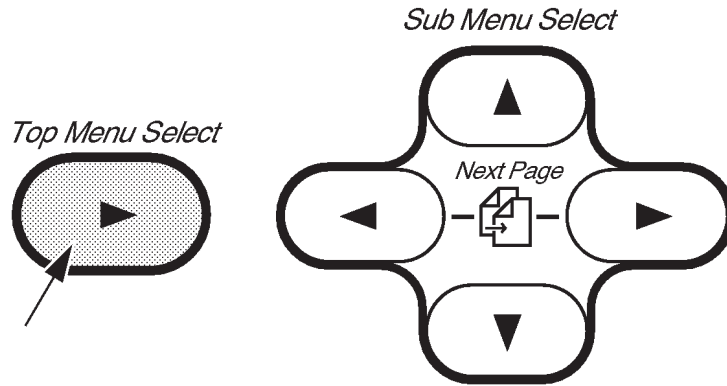

SOFTWARE MENU CONTROL KEYS
ILLUSTRATION 8-63

6. Press the Top Menu Select key again. The top menu is displayed on CRT monitor screen as shown in ILLUSTRATION 8-64.

B	Preset	Set Up	ECG	Archive	AutoSeq	CINE
---	--------	--------	------------	---------	---------	------

TOP MENU
ILLUSTRATION 8-64

7. Select the ECG Menu using the ◀ or ▶ key of Sub Menu Select keys. The ECG selection is displayed in reverse video as shown in ILLUSTRATION 8-64.
8. Press ▾ key to select the ECG Menu. The ECG Menu is displayed on the CRT monitor screen as shown in ILLUSTRATION 8-65.

ECG	1/3						
Single	Dual	Sync. Selectn	Ref. Scan	R Delay	ECG Wave	PCG Wave	AUX Wave
▼▲	▼▲	▼▲	▼▲	▼▲	▼▲	▼▲	▼▲

ECG MENU (a)
ILLUSTRATION 8-65

8-5-8 Operational Check-out (Continued)

9. Select the ECG Wave mode using the ◀ or ▶ key of Sub Menu Select keys. The ECG Wave selection is displayed in reverse video as shown in ILLUSTRATION 8-66.

ECG	1/3						
Single	Dual	Sync. Selectn	Ref. Scan	R Delay	ECG Wave	PCG Wave	AUX Wave
▼▲	▼▲	▼▲	▼▲	▼▲	▼▲	▼▲	▼▲

ECG MENU (b)
ILLUSTRATION 8-66

10. Press ▼ key to select the ECG Wave.
11. Check that the ECG waveform is displayed as shown in ILLUSTRATION 8-67.

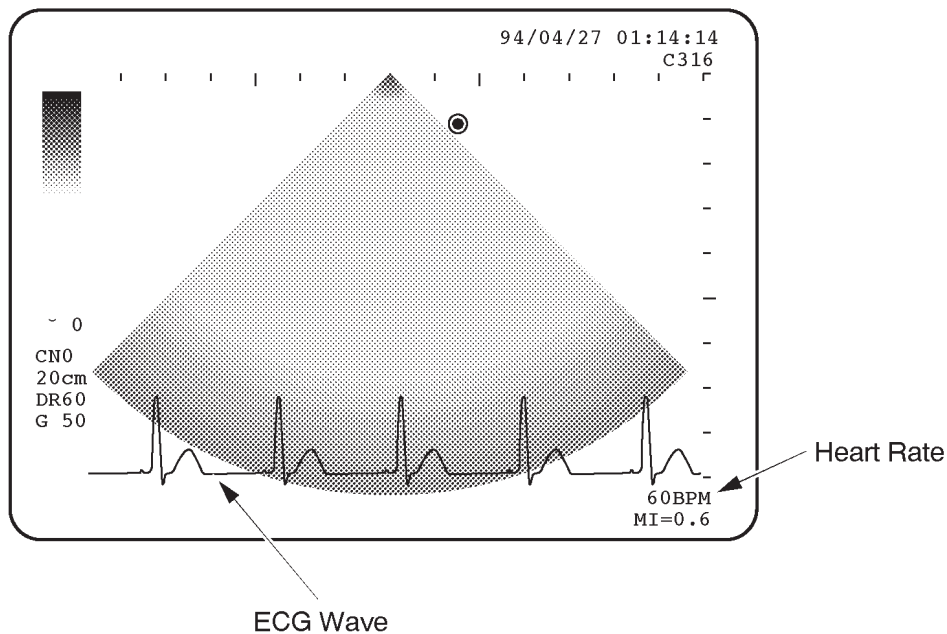

ECG WAVEFORM (a)
ILLUSTRATION 8-67

8-5-8 Operational Check-out (Continued)

- 12. Press the ◀ and ▶ keys of Sub Menu Select keys simultaneously to display the second menu. The ECG second menu is displayed as shown in ILLUSTRATION 8-68.

ECG	2 / 3		
ECG Gain	ECG Positn	PCG Gain	PCG Positn
-10	▼▲	-6	▼▲

ECG MENU (c)
ILLUSTRATION 8-68

- 13. Select the ECG Positn section using the ◀ or ▶ key of Sub Menu Select keys. The ECG Positn section is displayed in reverse video.
- 14. Check that the position of the ECG waveform moves vertically by means of pressing the ▲ or ▼ key of Sub Menu Select keys.
- 15. Select the ECG Gain section using the ◀ or ▶ key of Sub Menu Select keys. The ECG Gain section is displayed in reverse video.
- 16. Check that the size of the ECG waveform changes by means of pressing the ▲ or ▼ key of Sub Menu Select keys.
- 17. Check that the Heart Rate is displayed in XXXBPM at the lower right corner of the CRT monitor screen.
- 18. Press the ▼ and ▶ keys of Sub Menu Select keys simultaneously to display the first menu. The ECG first menu is displayed as shown in ILLUSTRATION 8-69.
- 19. Select the Dual section using the ◀ or ▶ key of Sub Menu Select keys. The Dual section is displayed in reverse video as shown in ILLUSTRATION 8-69.

ECG	1 / 3						
Single	Dual	Sync. Selectn	Ref. Scan	R Delay	ECG Wave	PCG Wave	AUX Wave
▼▲	▼▲	▼▲	▼▲	▼▲	▼▲	▼▲	▼▲

ECG MENU (d)
ILLUSTRATION 8-69

- 20. Press ▼ key to select the dual function.

8-5-8 Operational Check-out (Continued)

21. Check that the delay 1 markers (solid line) and delay 2 markers (broken line) appear on the CRT monitor screen as shown in ILLUSTRATION 8-70.

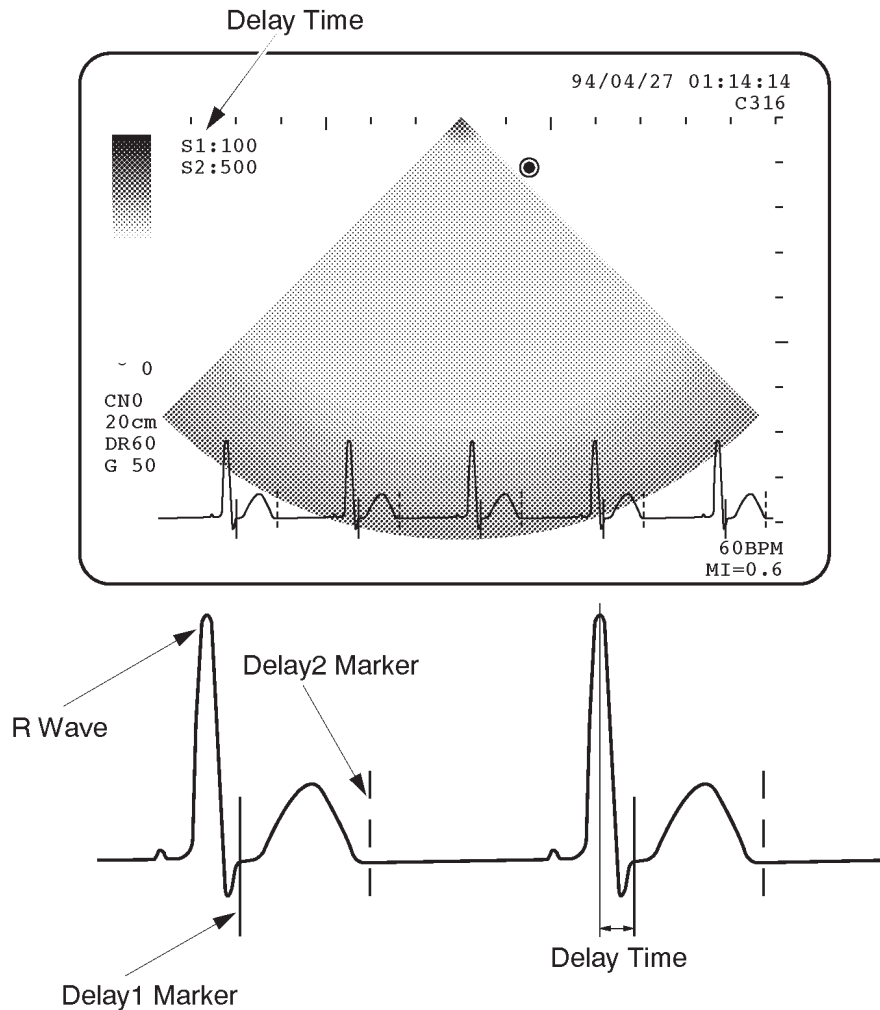

ECG WAVEFORM (b)
ILLUSTRATION 8-70

22. Rotate the trackball when the R delay displayed on the CRT monitor screen is highlighted and set the delay time 1 (S1) to 100 msec. The delay time 1 (S1) and 2 (S2) are displayed at the upper left position on the CRT monitor screen. Refer to ILLUSTRATION 8-70.

23. Select the Sync. Selectn section using the ◀ or ▶ key of Sub Menu Select keys. The Sync. Selectn section is displayed in reverse video.

24. Press ▾ key to set the delay time 2 (S2).

25. Rotate the trackball and set the delay time 2 (S2) to 500 msec.

26. Check that the frozen images are displayed continuously in accordance with the timing when each delay marker appears on the CRT monitor screen.

8-5-8 Operational Check-out (Continued)

27. Select the ECG Wave section using the ◀ or ▶ key of Sub Menu Select keys.

28. Press ⏏ key to exit the ECG mode. The ECG waveform will disappear.

■ 29. Connect the PCG sensor with the ECG panel. Refer to ILLUSTRATION 8-71.

Note

If your customer does not need the PCG sensor or you have not any PCG sensors, skip to step 42.

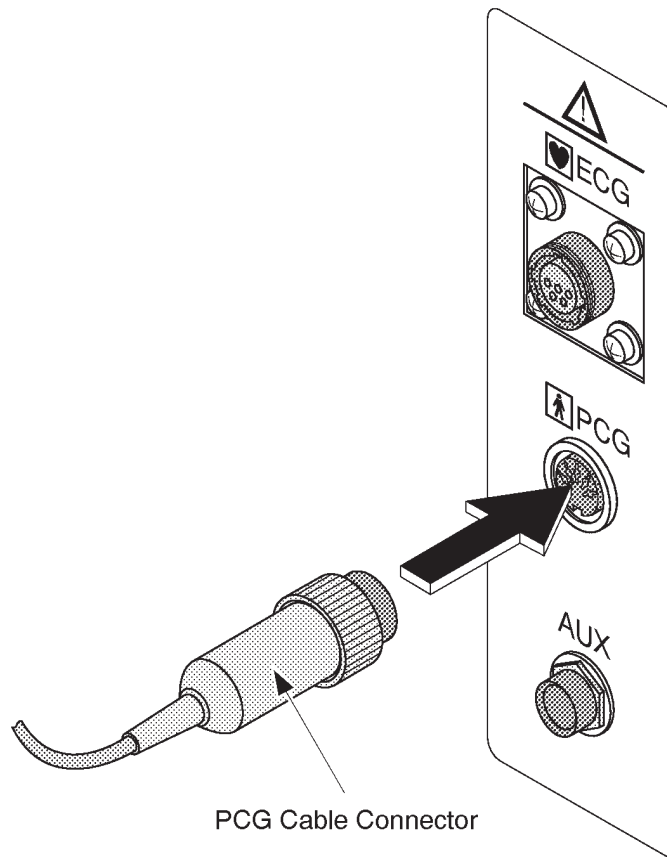

CONNECTING PCG SENSOR
ILLUSTRATION 8-71



8-5-8 Operational Check-out (Continued)

- 30. Select the PCG Wave section using the ◀ or ▶ key of Sub Menu Select keys. The PCG Wave section is displayed in reverse video as shown in ILLUSTRATION 8-72.

ECG	1/3						
Single	Dual	Sync. Selectn	Ref. Scan	R Delay	ECG Wave	PCG Wave	AUX Wave
▼▲	▼▲	▼▲	▼▲	▼▲	▼▲	▼▲	▼▲

ECG MENU (e)
ILLUSTRATION 8-72

- 31. Press ▾ key to select the PCG Wave.
- 32. The PCG waveform is displayed on the CRT monitor screen as shown in ILLUSTRATION 8-73.

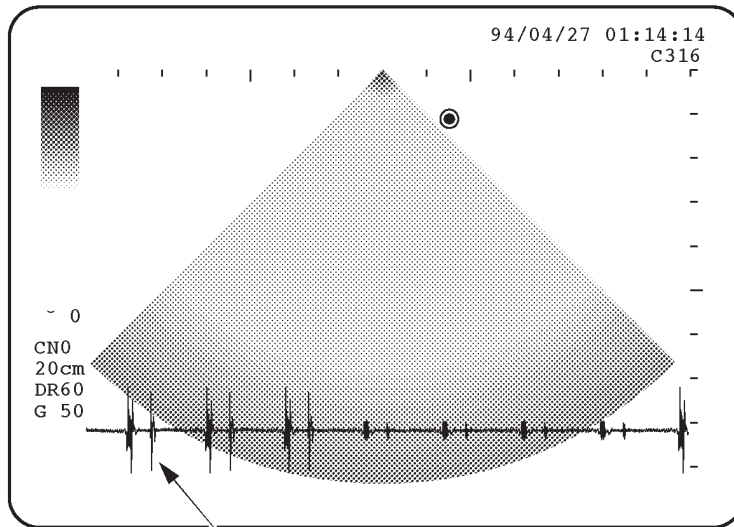

PCG Wave

PCG WAVEFORM
ILLUSTRATION 8-73

- 33. Check that the PCG waveform is displayed by means of patting the PCG sensor.

8-5-8 Operational Check-out (Continued)

- 34. Press the ◀ and ▶ keys of Sub Menu Select keys simultaneously to display the second menu. The ECG second menu is displayed as shown in ILLUSTRATION 8-68.
- 35. Select the PCG Positn section using the ◀ or ▶ key of Sub Menu Select keys. The PCG Positn section is displayed in reverse video.
- 36. Check that the position of the PCG waveform moves vertically by means of pressing the ▲ or ▼ key of Sub Menu Select keys.
- 37. Select the PCG Gain section using the ◀ or ▶ key of Sub Menu Select keys. The PCG Gain section is displayed in reverse video.
- 38. Check that the size of the PCG waveform changes by means of pressing the ▲ or ▼ key of Sub Menu Select keys.
- 39. Press the ▼ and ▶ keys of Sub Menu Select keys simultaneously to display the first menu. The ECG first menu is displayed on the CRT monitor screen.
- 40. Select the PCG Wave section using the ◀ or ▶ key of Sub Menu Select keys.
- 41. Press ▼ key to exit the PCG mode. The PCG waveform will disappear.
- 42. Connect the function generator with the AUX connector on the ECG panel assy.

Note

Use a adapter plug to connect the function generator as necessary.

- 43. Input the 2Vp-p, 1Hz signal into the system using the function generator.
- 44. Select the AUX Wave section using the ◀ or ▶ key of Sub Menu Select keys. The AUX Wave section is displayed in reverse video as shown in ILLUSTRATION 8-74.

ECG	1/3						
Single	Dual	Sync. Selectn	Ref. Scan	R Delay	ECG Wave	PCG Wave	AUX Wave
▼▲	▼▲	▼▲	▼▲	▼▲	▼▲	▼▲	▼▲

ECG MENU (f)
ILLUSTRATION 8-74



- 45. Press ▼ key to select the AUX Wave.

8-5-8 Operational Check-out (Continued)

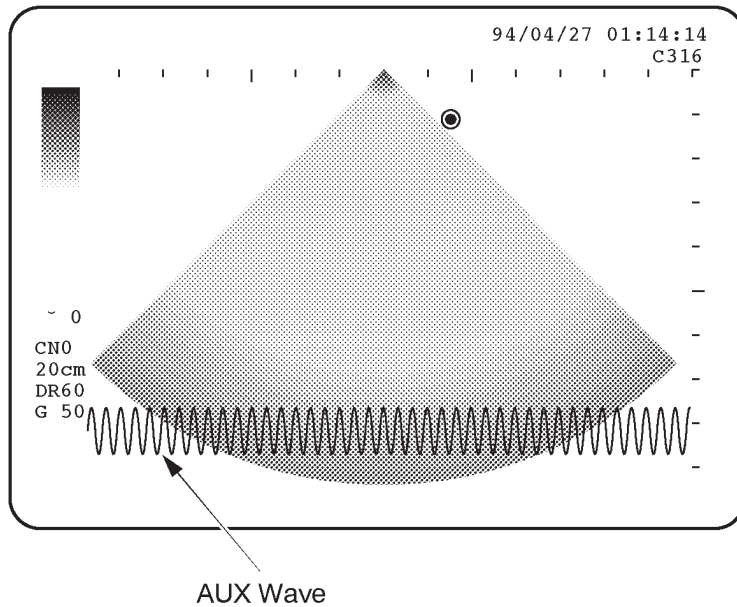
- 46. Make sure that the AUX waveform is displayed as shown in ILLUSTRATION 8-75.



AUX WAVEFORM
ILLUSTRATION 8-75

- 47. Press the  and  keys of Sub Menu Select keys simultaneously to display the third menu. The ECG third menu is displayed as shown in ILLUSTRATION 8-76.

ECG	3/3
AUX Gain	AUX Positn
-6	▼▲

ECG MENU (g)
ILLUSTRATION 8-76

8-5-8 Operational Check-out (Continued)

48. Select the AUX Positn section using the ◀ or ▶ key of Sub Menu Select keys. The AUX Positn section is displayed in reverse video.
49. Check that the position of the AUX waveform moves vertically by means of pressing the ▲ or ▼ key of Sub Menu Select keys.
50. Select the AUX Gain section using the ◀ or ▶ key of Sub Menu Select keys. The AUX Gain section is displayed in reverse video.
51. Check that the size of the AUX waveform changes by means of pressing the ▲ or ▼ key of Sub Menu Select keys.
52. Press the ▼ and ▶ keys of Sub Menu Select keys simultaneously to display the first menu. The ECG first menu is displayed on the CRT monitor screen.
53. Select the AUX Wave section using the ◀ or ▶ key of Sub Menu Select keys.
54. Press ▼ key to exit the AUX mode. The AUX waveform will disappear.
55. Perform leakage current test.

8-5-9 Attaching Caution Label

1. Turn the system power OFF.
2. Attach the Caution Label onto the Side Cover Right as shown in ILLUSTRATION 8-77.

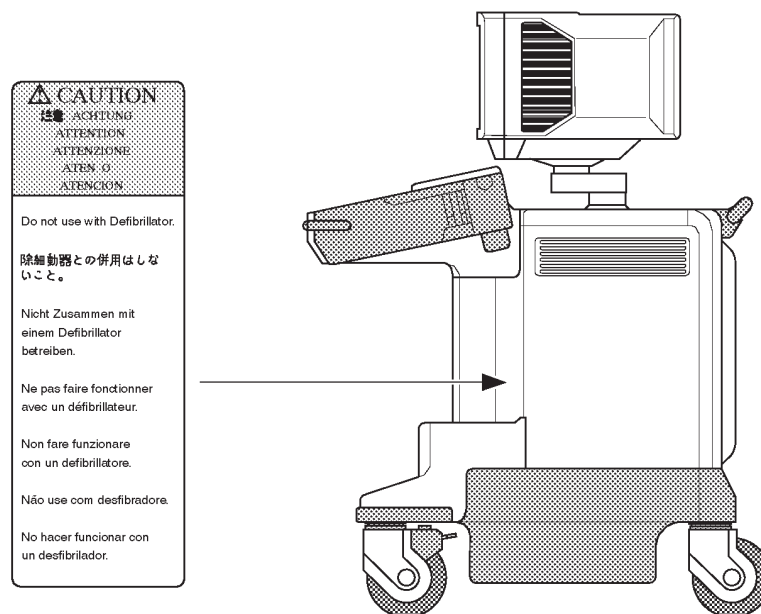

ATTACHING CAUTION LABEL

ILLUSTRATION 8-77

8-5-10 Final Procedures

1. Remove the Side Cover Left. Refer to 6-2-26 in Chapter 6, Renewal Parts.
- 2. Attach the Option Label onto the Nest Cover. Refer to ILLUSTRATION 8-78.

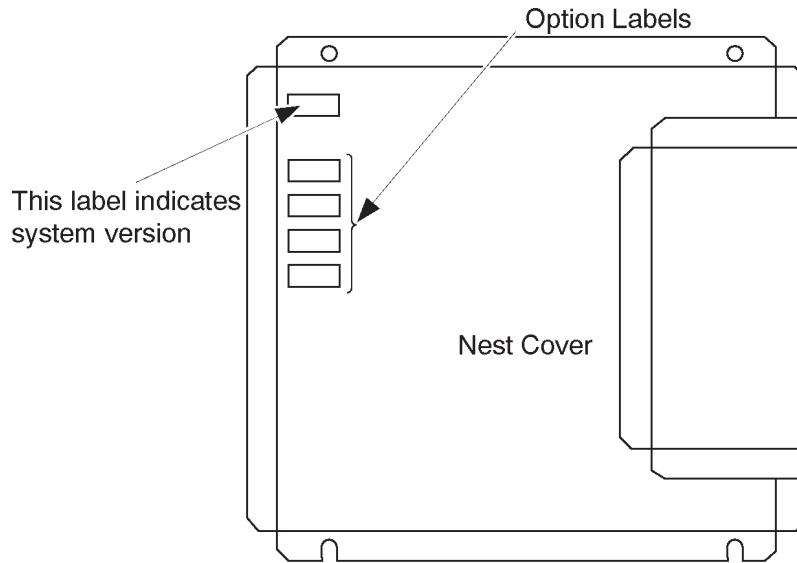

NEST COVER
ILLUSTRATION 8-78

3. Re-install the Side Cover Left.

8-5-10 Final Procedures (Continued)

- 4. Fill out the proper customer information on the Product Locator Card. Refer to ILLUSTRATION 8-79. Mail the installation card "Product Locator" to the address corresponding to your region.

		Mailing Address GE Medical Systems Product Locator File P.O. Box 414 Milwaukee, WI 53201-0414			
		DESCRIPTION	FDA	MODEL	REV
PREPARE FOR ORDERS THAT DO NOT HAVE A LOCATOR INSTALLATION REPORT		OCP	BS	ORD	DATE (MO-DA-YR)
		DIST.:COUNTRY	ROOM	EMPLOYEE NO.	
SYSTEM ID NUMBER		CUSTOMER NO.			
PRINTED IN USA INSTALLATION INSTALLATION		DESTINATION - NAME AND ADDRESS			

		ZIP CODE			

PRODUCT LOCATOR CARD
ILLUSTRATION 8-79

Note

The Product Locator Card indicated in ILLUSTRATION 8-79 may be different from the actually provided one.

- 5. Properly dispose of excess material.
- 6. This completes the installation of the LOGIQ™ 400 ECG Option.

8-5-11 Renewal Parts

ITEM	PART NAME	PART NO.	QTY.	DESCRIPTION
1	ECG BOARD ASSY	P9522WZ	1	
	 ECG BOARD2 ASSY	2207806	1	Old ECG Board Assy (P9522WZ) can be replaced with new ECG Board Assy (2207806)
2	ECG PANEL ASSY	P9522XB	1	
3	ECG CABLE (System side)	P9509KC	1	For Japan
	ECG CABLE (System side)	P9509KE	1	For USA, Europe, and others
4	ECG CABLE (Patient side)	P9509KD	1	For Japan
	ECG CABLE (Patient side)	P9509KF	1	For USA, Europe, and others
5	PCG SENSOR	P9509KN	1	

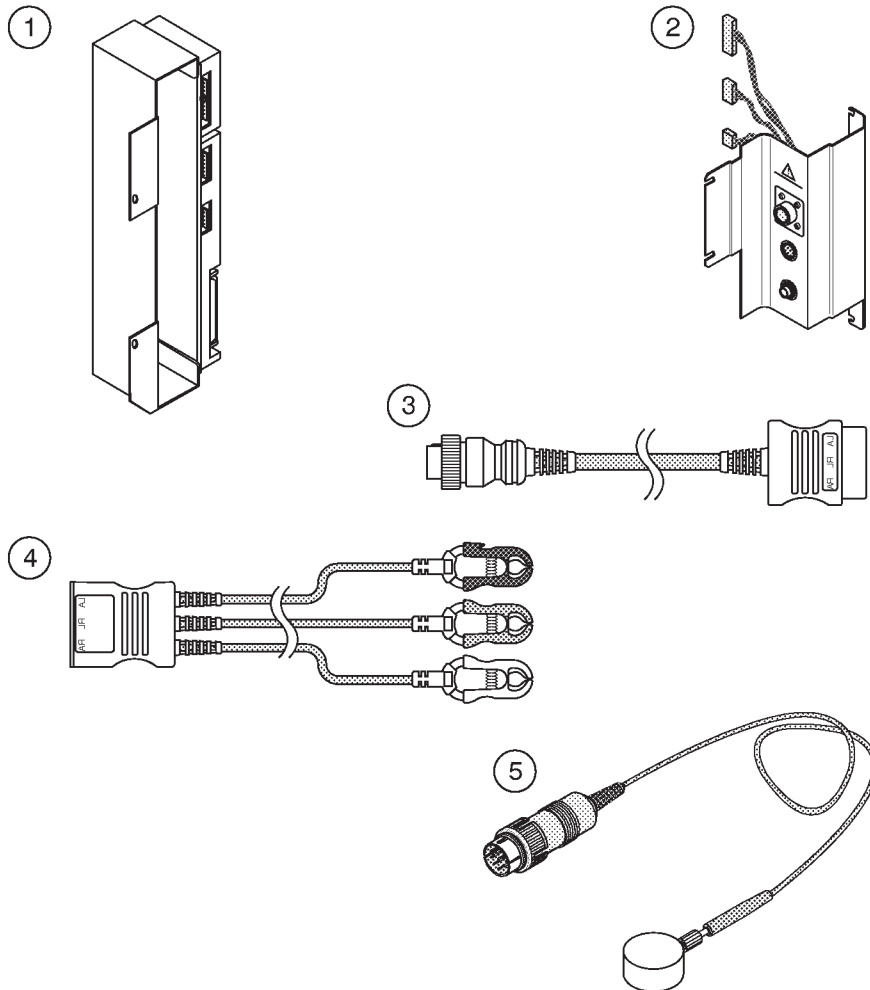

RENEWAL PARTS
ILLUSTRATION 8-80

8-6 EXPANDED CINE MEMORY INSTALLATION

8-6-1 Foreword

This section describes the installation of the Expanded Cine Memory option for LOGIQ™ 400. This upgrade expands the capacity of cine memory by 5 times over the standard capacity.

8-6-2 Tools Required

Standard field Service Tool kit

8-6-3 Time Required

Approx. 1 Hour

8-6-4 Parts Required

ITEM	PART NAME	QTY	PART #	REMARKS
1.	Add Cine Memory	1	P9523UC	
	OMEM Assy	1	P9525WU	
	Stud	1	U0053AG	
	Screw	2	—	
	Option Label	1	—	

8-6-5 Functional Check-out

READ and UNDERSTAND these instructions thoroughly before proceeding with the installation. Perform each step in sequence and check it off when completed. If a problem occurs after completion, go back through the procedure and check for implementation errors before contacting your Ultrasound Region Engineer.



Possible operational damage. Failure to strictly follow ESD (Electrostatic Discharge) precautions during this upgrade may cause constant or intermittent operational abnormalities. Strictly follow all precautions.

Check each step as it is completed.

Perform functional checks to verify that the system is functioning properly. Refer to Chapter 4, Functional Checks.

8-6-6 Accessing Board Assy

CAUTION

Possible operational damage. Be sure to turn OFF power and wear the ESD wrist strap before you remove a circuit boards.

1. Turn the system power OFF and unplug the unit. Follow the OSHA Lockout/Tagout Requirements (29 CFR 1910.147, Direction 46-015902).
2. Remove the Side Cover Left. Refer to 6-2-26 in Chapter 6, Renewal Parts.
3. Unscrew five screws and remove the Nest Cover as shown in ILLUSTRATION 8-81.
4. Turn the upper and lower ejectors on slot 9 in the direction indicated by the arrow (①). Refer to ILLUSTRATION 8-81.
5. Pull the TLMC Assy straightforwards in the direction indicated by the arrow (②). Refer to ILLUSTRATION 8-81.

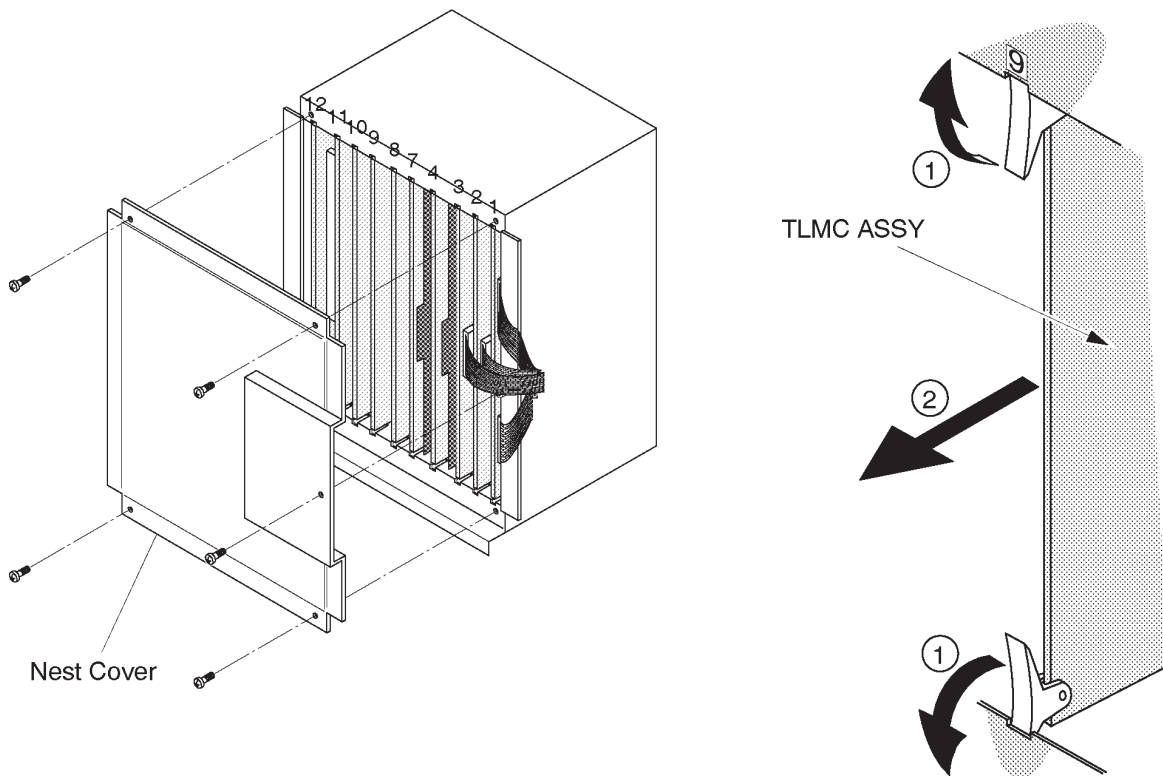

ACCESSING BOARDS
ILLUSTRATION 8-81

8-6-7 Installing OMEM Assy

- 1. Screw one screw (①) to assemble the stud onto the TLMC Assy as shown in ILLUSTRATION 8-82.

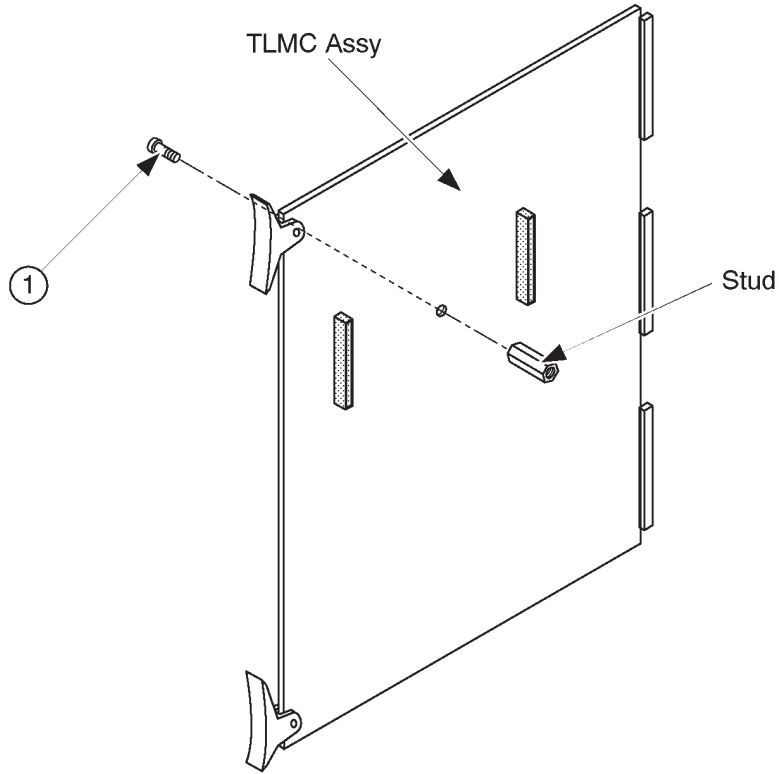

ASSEMBLING STUD
ILLUSTRATION 8-82

8-6-7 Installing OMEM Assy (Continued)

2. Connect the two connectors and screw one screw (①) to assemble the OMEM Assy onto the TLMC Assy as shown in ILLUSTRATION 8-83.

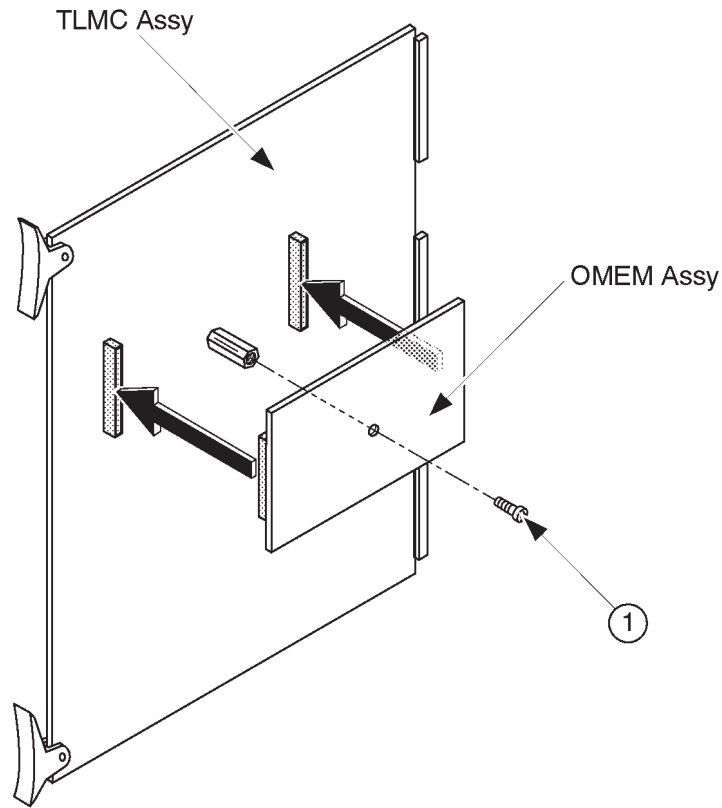

ASSEMBLING OMEM ASSY
ILLUSTRATION 8-83

3. Re-install the TLMC Assy into the slot 9 of the Nest and turn the upper and lower ejectors to fix the board firmly.
4. Screw five screws to install the Nest Cover.

8-6-8 Operational Check-out

1. Plug the unit and turn the system power ON.
2. Set the following conditions by operating the keyboard. Refer to LOGIQ™ 400 User Manual.
 - a. B/CFM mode
 - b. Depth: Maximum (20 cm)
 - c. CFM Area: Maximum
 - d. Adjust the BW Gain and CFM Gain so that the CFM noise appears wholly in the CFM area.
3. Do the scanning for 30 seconds and press the Freeze button.
4. Turn the Cine Scroll potentiometer clockwise.
5. Check that the cine gauge appears at the bottom of the B-mode image as shown in ILLUSTRATION 8-84.

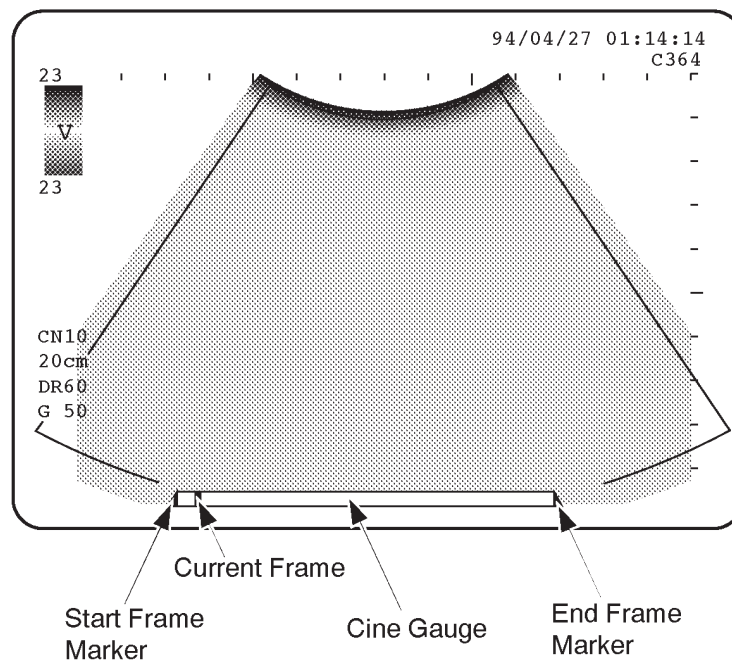

CINE MODE SCREEN
ILLUSTRATION 8-84

6. Turn the Cine Scroll potentiometer counterclockwise to move the cursor indicating the current frame to the right-most position of the cine gauge.
7. Check that the approximately 150 frames are stored in memory by reading the CN number displayed at the left side of the screen.
8. Check that the cine images are displayed normally.

8-6-9 Final Procedures

1. Turn the system power OFF.
2. Attach the Option Label onto the Nest Cover.

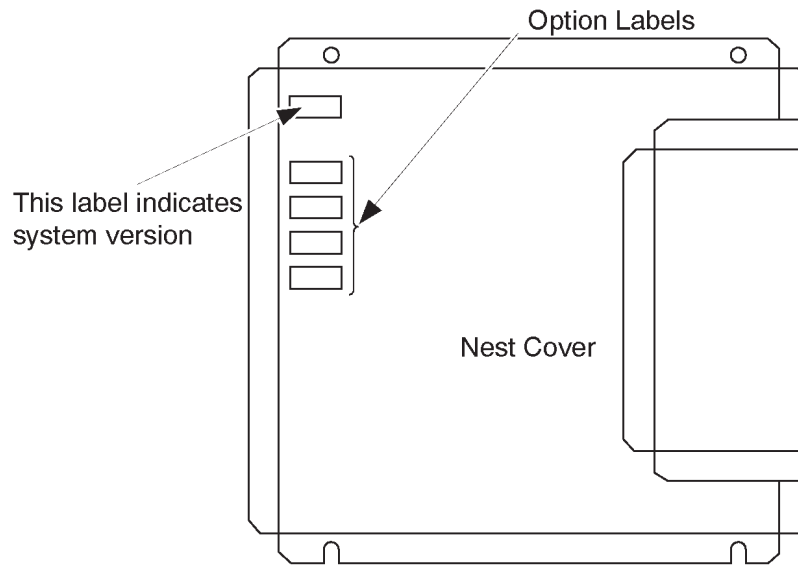

OPTION LABEL
ILLUSTRATION 8-85

3. Install the Side Cover Left. Refer to 6-2-26 in Chapter 6.

8-6-9 Final Procedures (Continued)

- 4. Fill out the proper customer information on the Product Locator Card. Refer to ILLUSTRATION 8-86. Mail this installation Card "Product Locator" to the address corresponding to your pole.

		Mailing Address GE Medical Systems Product Locator File P.O. Box 414 Milwaukee, WI 53201-0414			
DESCRIPTION	FDA	MODEL	REV	SERIAL	
PREPARE FOR ORDERS THAT DO NOT HAVE A LOCATOR INSTALLATION REPORT		OCP	BS	ORD	DATE (MO-DA-YR)
SYSTEM ID NUMBER		DIST. COUNTRY	ROOM	EMPLOYEE NO.	
INSTALLATION		CUSTOMER NO.			
PRINTED IN USA		DESTINATION - NAME AND ADDRESS			
INSTALLATION		_____ _____ _____			
		ZIP CODE			

PRODUCT LOCATOR INSTALLATION CARD
ILLUSTRATION 8-86

Note

The Product Locator Card indicated in ILLUSTRATION 8-86 may be different from the actually provided one.

- 5. Properly dispose of excess material.
- 6. This completes the installation of the Expanded Cine Memory Option for LOGIQ™ 400.

8-6-10 Renewal Parts

ITEM	PART NAME	PART NO.	QTY.	DESCRIPTION
1	OMEM ASSY	P9525WU	1	
2	STUD	U0053AG	1	

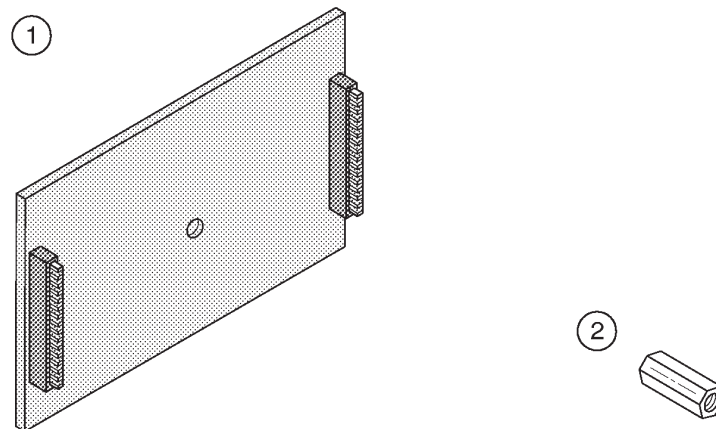

RENEWAL PARTS
ILLUSTRATION 8-87

8-7 FOOT SWITCH INSTALLATION

8-7-1 Foreword

This section describes the installation of the Foot Switch option for LOGIQ™ 400.

8-7-2 Tools Required

Standard field Service Tool kit

8-7-3 Time Required

Approx. 15 Minutes

8-7-4 Parts Required

ITEM	PART NAME	QTY	PART #	REMARKS
1.	Foot Switch	1	P9509NB	

8-7-5 Functional Check-out

READ and UNDERSTAND these instructions thoroughly before proceeding with the installation. Perform each step in sequence and check it off when completed. If a problem occurs after completion, go back through the procedure and check for implementation errors before contacting your Ultrasound Region Engineer.



Possible operational damage. Failure to strictly follow ESD (Electrostatic Discharge) precautions during this upgrade may cause constant or intermittent operational abnormalities. Strictly follow all precautions.

Check each step as it is completed.

Perform functional checks to verify that the system is functioning properly. Refer to Chapter 4, Functional Checks.

8-7-6 Connecting Foot Switch

1. Turn the system power OFF. Follow the OSHA Lockout/Tagout Requirements (29 CFR 1910.147, Direction 46-015902).
2. Open the Rear Door.
- 3. Connect the Foot Switch with the connector on the rear panel as shown in ILLUSTRATION 8-88.

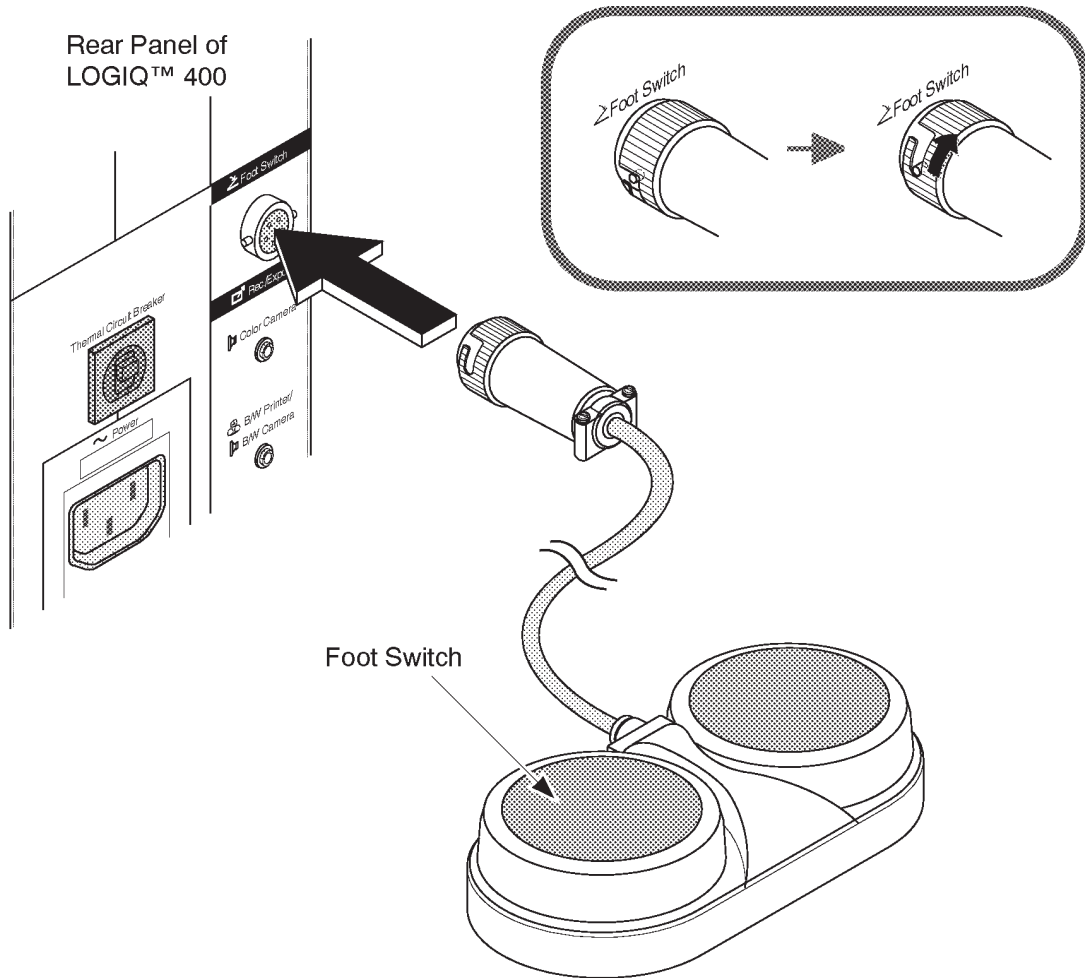

FOOT SWITCH CONNECTION
ILLUSTRATION 8-88

8-7-7 Operational Check-out

1. Turn the system power ON.
2. Check that depressing the left switch of the Foot Switch causes the image displayed on the CRT monitor screen to freeze.
3. Check that depressing the right switch of the Foot Switch causes the recording device, assigned to Record 1 by system parameter set-up, to record the currently displayed image.

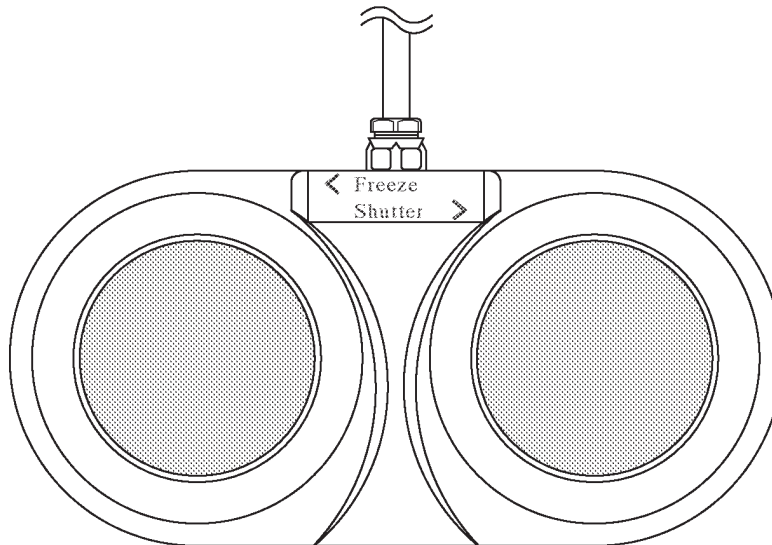

FOOT SWITCH
ILLUSTRATION 8-89

8-7-8 Final Procedures

1. Properly dispose of excess material.
2. This completes the installation of the LOGIQ™ 400 Foot Switch Option.

8-8 SWIVEL LOCK INSTALLATION

8-8-1 Foreword

This section describes the installation of the Swivel Lock option for LOGIQ™ 400.

8-8-2 Tools Required

Standard field Service Tool kit

8-8-3 Time Required

Approx. 30 Minutes

8-8-4 Parts Required

ITEM	PART NAME	QTY	PART #	REMARKS
1.	Swivel Lock	1	U0144AE	

8-8-5 Functional Check-out

READ and UNDERSTAND these instructions thoroughly before proceeding with the installation. Perform each step in sequence and check it off when completed. If a problem occurs after completion, go back through the procedure and check for implementation errors before contacting your Ultrasound Region Engineer.



Possible operational damage. Failure to strictly follow ESD (Electrostatic Discharge) precautions during this upgrade may cause constant or intermittent operational abnormalities. Strictly follow all precautions.

Check each step as it is completed.

Perform functional checks to verify that the system is functioning properly. Refer to Chapter 4, Functional Checks.

8-8-6 Installing Swivel Lock

1. Turn the system power OFF. Follow the OSHA Lockout/Tagout Requirements (29 CFR 1910.147, Direction 46-015902).
2. Unscrew inside two hexagonal bolts fixing the left-side front caster to the frame as shown in ILLUSTRATION 8-90.

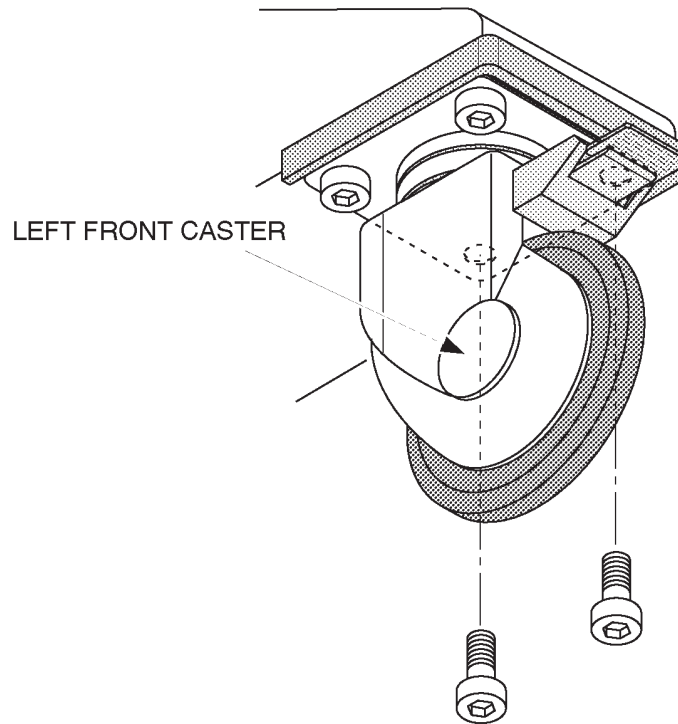

HEXAGONAL BOLTS REMOVAL
ILLUSTRATION 8-90

8-8-6 Installing Swivel Lock (Continued)

- 3. Reinstall two hexagonal bolts to install the swivel lock as shown in ILLUSTRATION 8-91.

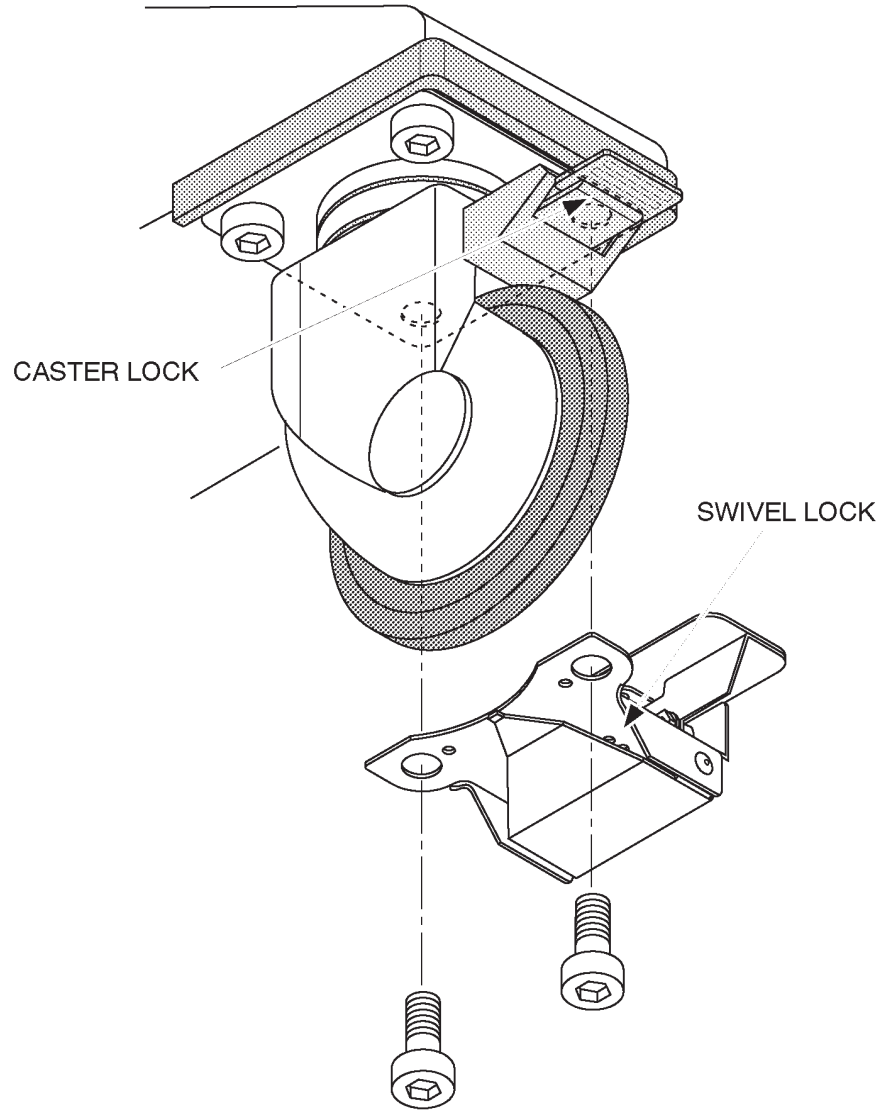

SWIVEL LOCK INSTALLATION
ILLUSTRATION 8-91

8-8-7 Operational Check-out

1. Push the front side of swivel lock downwards by foot as shown in ILLUSTRATION 8-92.

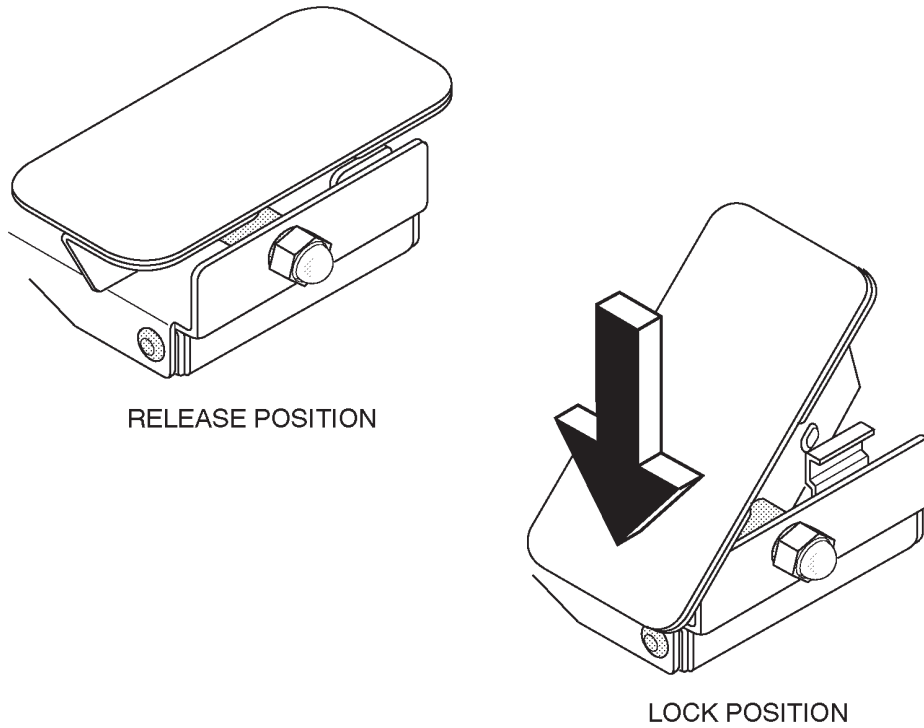

SWIVEL LOCK
ILLUSTRATION 8-92

2. Move the LOGIQ™ 400 console. When the lock lever on the front caster faces just forwards, the swivel mechanism is locked.
3. Try to roll the LOGIQ™ 400 console and check that the left-side front caster does not rotate.
4. Push the back side of swivel lock down by foot.
5. Try to roll the LOGIQ™ 400 console again and check that the swivel lock mechanism is released.

8-8-8 Final Procedures

1. Properly dispose of excess material.
2. This completes the installation of the optional Swivel Lock for LOGIQ™ 400.

8-9 LEFT SIDE PROBE HOLDER INSTALLATION

8-9-1 Foreword

This section describes the installation of the Left Side Probe Holder option for LOGIQ™ 400.

8-9-2 Tools Required

Standard field Service Tool kit

8-9-3 Time Required

Approx. 30 Minutes

8-9-4 Parts Required

ITEM	PART NAME	QTY	PART #	REMARKS
1.	Left Side Probe Holder	1	P9522XD	

8-9-5 Installing Left Side Probe Holder

1. Turn the system power OFF.
2. Unscrew three screws to remove the keyboard panel assy. Refer to sub-section 6-2-49 in Chapter 6, RENEWAL PARTS.
3. Unscrew two screws and remove the box holder cover as shown in ILLUSTRATION 8-93.

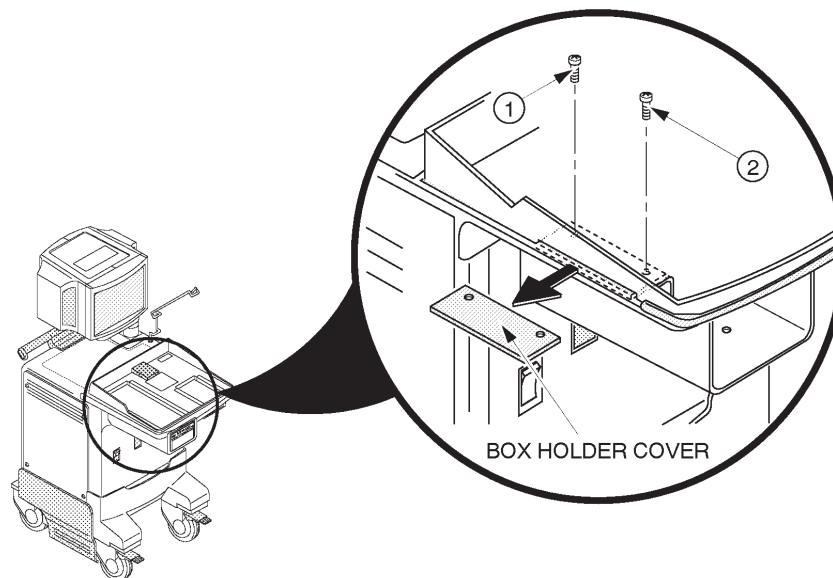

BOX HOLDER COVER REMOVAL
ILLUSTRATION 8-93

8-9-5 Installing Left Side Probe Holder (Continued)

4. Install the left side probe holder as shown in ILLUSTRATION 8-94.

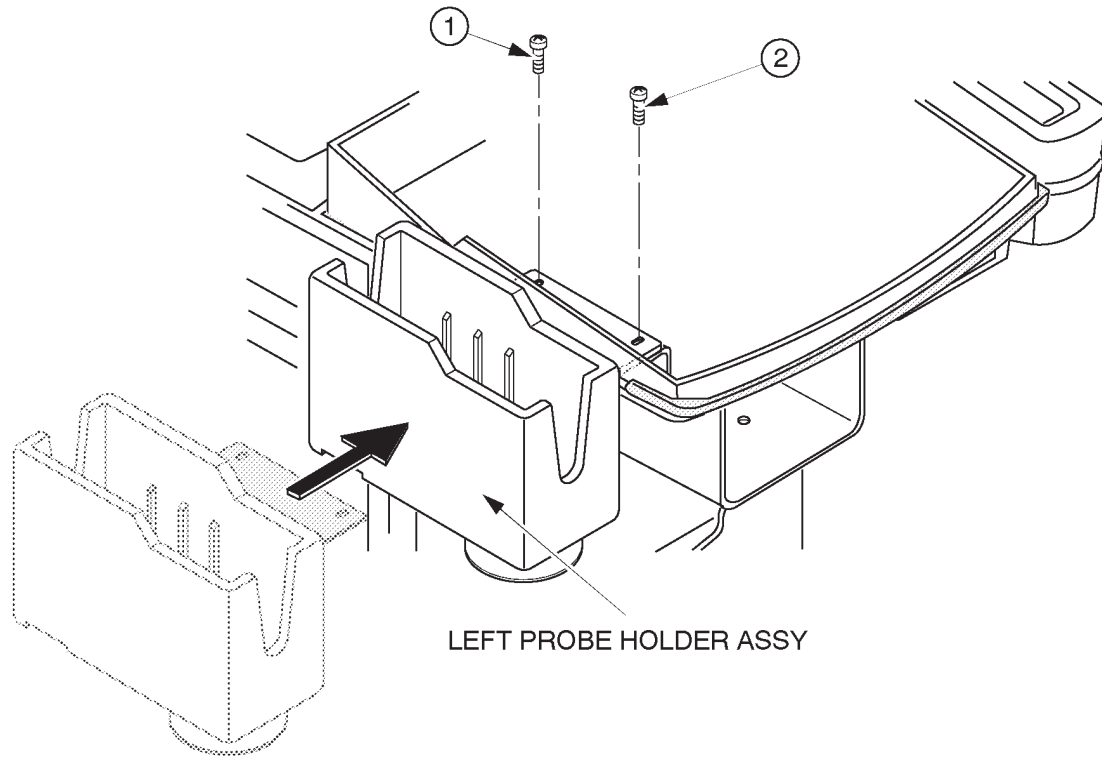

LEFT SIDE PROBE HOLDER INSTALLATION

ILLUSTRATION 8-94

5. Re-assemble the keyboard panel assy.

8-9-6 Operational Check-out

1. Turn the system power ON.
2. Perform functional checks to verify that the keyboard panel assy is assembled correctly. Refer to Chapter 4, FUNCTIONAL CHECKS.
3. Check that the left side probe holder is installed firmly.

8-9-7 Final Procedures

1. Properly dispose of excess material.
2. This completes the installation of the optional Left Side Probe Holder for LOGIQ™ 400.

8-10 MTZ PROBE HOLDER INSTALLATION

8-10-1 Foreword

This section describes the installation of the MTZ Probe Holder option for LOGIQ™ 400.

8-10-2 Tools Required

Standard field Service Tool kit

8-10-3 Time Required

Approx. 10 Minutes

8-10-4 Parts Required

ITEM	PART NAME	QTY	PART #	REMARKS
1.	MTZ Probe Holder	1	P9522XM	

8-10-5 Installing MTZ Probe Holder

Note

The MTZ probe holder is supplied with a console except for the Japanese system.

1. Install the MTZ probe holder as shown in ILLUSTRATION 8-95.

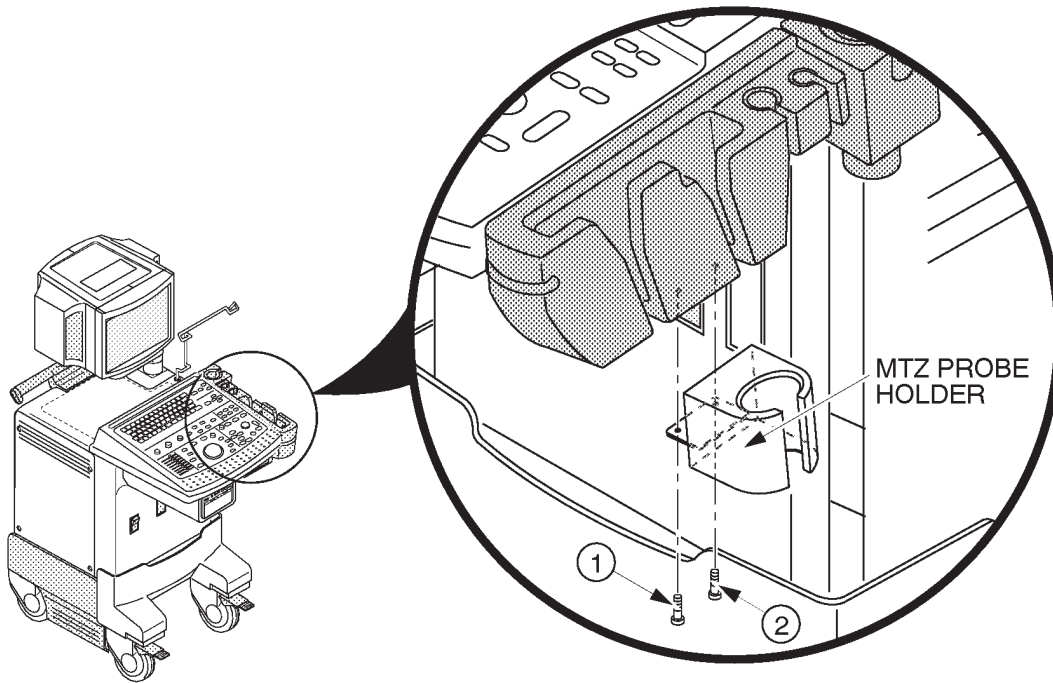

MTZ PROBE HOLDER INSTALLATION

ILLUSTRATION 8-95

2. Check that the MTZ probe holder is installed firmly.

8-10-6 Final Procedures

1. Properly dispose of excess material.
2. This completes the installation of the optional MTZ Probe Holder for LOGIQ™ 400.