

# ECODRIVE DKC01.1/DKC11.1 Drive Controllers

Project Planning Manual

DOK-ECODRV-DKC01/11.1\*-PRJ3-EN-P



<b>Title</b>	ECODRIVE DKC01.1/DKC11.1 Drive Controllers
<b>Type of document</b>	Project Planning
<b>Document code</b>	DOK-ECODRV-DKC01/11.1*-PRJ3-EN-P
<b>Internal file reference</b>	<ul style="list-style-type: none"> <li>209-0069-4390-03</li> </ul>

**Editing sequence**

Document identification of previous editions	Date	Remark
209-0069-4390-00 EN/05.96	May 96	First edition
209-0069-4390-01 EN/06.96	June 96	Revision
DOK-ECODRV-DKC01/11.1*-PRJ1-EN-P	July 96	2nd edition
DOK-ECODRV-DKC01/11.1*-PRJ1-EN-P	May 97	2nd Revision
DOK-ECODRV-DKC01/11.1*-PRJ3-EN-P	Feb. 98	new edition

**Copyright** © INDRAMAT GmbH, 1996

The reproduction and transmission of this document, the use and communication of its content to third parties without the expressed consent of INDRAMAT GmbH are forbidden. Violators are liable for the payment of damages. All rights are reserved in the event a patent is granted or a utility model is registered (DIN 34-1).

**Publisher** INDRAMAT GmbH • Bgm.-Dr.-Nebel-Str. 2 • D-97816 Lohr a. Main  
Telephone +49 (09352) 40-0 • Telex 689421 • Fax +49 (09352) 40-4885  
Dept. ENA (VS, HE)

**Validity** The contents of this documentation and the availability of the product are subject to change.

<b>What is this documentation for?</b>	<p>It supplies information on:</p> <ul style="list-style-type: none"><li>• planning the mechanical control cabinet</li><li>• planning the electrical system in the control cabinet</li><li>• logistic handling of the equipment</li><li>• preparing the resources for start-up</li></ul>
<b>Supplementary documentation</b>	<p>"ECODRIVE DKC Servo Drives with MKD" - Selection Lists - DOK-ECODRV-DKC+MKD****-AUS1-EN-P for selecting the motor controller combination.</p> <p>"MKD Digital AC Motors" - Project Planning Manual - DOK-MOTOR*-MKD*****-PRJ2-EN-P for a detailed description of the servomotors and for the selection of the required cable.</p> <p>"ECODRIVE DKC01.1/DKC11.1 Drive Controllers" - Description of Functions - DOK-ECODRV-DKC01/11.1-FKB1-EN-P for testing and selecting the functions.</p> <p>"EMC in Drive and Control Systems" - Project Planning - 209-0049-4305-02 EN/04.96 for the EMC-compliant planning and installation of the drive system (EMC = Electromagnetic Compatibility).</p>

## Notes

# Table of contents

<b>1 Introduction to the system</b>	<b>1-1</b>
1.1 Application features.....	1-1
1.2 Overview of the functions.....	1-1
<b>2 Safety instructions for electrical drives</b>	<b>2-1</b>
2.1 General .....	2-1
2.2 Protection against contact with electrical parts .....	2-2
2.3 Protection against shocks caused by safety extra-low voltage (SELV).....	2-3
2.4 Protection against dangerous movements.....	2-4
2.5 Protection against magnetic and electromagnetic fields during operation and assembly .....	2-6
2.6 Protection during handling and assembly .....	2-7
2.7 Safe battery usage .....	2-7
<b>3 Selecting the components</b>	<b>3-1</b>
3.1 Overview of the required components .....	3-1
3.2 Selection procedure .....	3-2
3.3 Compiling the required data .....	3-3
<b>4 ECODRIVE DKC drive controllers</b>	<b>4-1</b>
4.1 Hardware.....	4-1
View of unit.....	4-1
Dimensional sheets and installation dimensions.....	4-2
Technical data .....	4-4
Type code and rating plate.....	4-7
4.2 Firmware .....	4-8
4.3 An overview of the electrical connections.....	4-9
Front view with supply terminals .....	4-9
Overall connection diagrams.....	4-10
4.4 Electrical connection to the supply terminal strips .....	4-14
Serial interface X1 .....	4-14
X2 positioning or stepper interface.....	4-18
X3 analog inputs and outputs.....	4-25
X4 terminals for the control circuit.....	4-29
X5, X6, X7 motor connections .....	4-30
X9 DC bus connection .....	4-30

<b>5 BZM auxiliary bleeder module</b>	<b>5-1</b>
5.1 Dimensioning the components relevant for regeneration .....	5-1
5.2 Dimensional data and installation dimensions .....	5-5
5.3 Technical data.....	5-6
5.4 Front view.....	5-6
5.5 Electrical connections .....	5-7
5.6 Type code and rating plate.....	5-7
<b>6 CZM Auxiliary Capacitance Module</b>	<b>6-1</b>
6.1 Dimensioning .....	6-1
6.2 Dimensional data and installation dimensions .....	6-3
6.3 Front view.....	6-4
6.4 Electrical connection .....	6-4
6.5 Type code and rating plate.....	6-5
<b>7 DC24V NTM power supplies</b>	<b>7-1</b>
7.1 Application recommendations.....	7-1
7.2 Technical data.....	7-1
7.3 Dimensional data and installation dimensions .....	7-2
7.4 Front views.....	7-2
7.5 Electrical connection .....	7-3
7.6 Type code .....	7-4
<b>8 NFD / NFE line filter</b>	<b>8-1</b>
8.1 Selection .....	8-1
8.2 Dimensional data and installation dimensions .....	8-2
8.3 Electrical connection .....	8-3
8.4 Line filters for DC24V NTM power supplies .....	8-5
8.5 Type code .....	8-5
<b>9 DST / DLT transformers</b>	<b>9-1</b>
9.1 Selection .....	9-1
9.2 Autotransformers for DKC**.*-040-7-FW .....	9-1
9.3 Autotransformers for DKC**.*-030-3-FW .....	9-4
9.4 Electrical connection of the DKC via transformer .....	9-6
9.5 Type code .....	9-7
<b>10 Planning the control cabinet</b>	<b>10-1</b>
10.1 Notes on installing the control cabinet .....	10-1
Power dissipation .....	10-1
10.2 Using heat-exchange units in the control cabinets .....	10-2

<b>11 Power connection</b>	<b>11-1</b>
11.1 Direct power connection.....	11-1
11.2 Line contactor/fuse protector .....	11-2
Calculating the phase current at the power connection .....	11-2
Selecting fuse protector Q1 and line contactor K1 .....	11-3
11.3 Control circuit to the power connection.....	11-4
11.4 Protection against indirect contact.....	11-5
<b>12 Preparing for Startup</b>	<b>12-1</b>
Required equipment.....	12-1
<b>13 Condition of the drive components on delivery</b>	<b>13-1</b>
Packaging .....	13-1
Accompanying documents .....	13-1
Identification of the components .....	13-1
<b>14 Index</b>	<b>14-1</b>

**Notes**



# 1 Introduction to the system

## 1.1 Application features

The drive system with the ECODRIVE drive controllers is the most cost-effective solution offering the highest functionality for almost any field of application in which translatory or rotary motions are to be automated.

Outstanding performance data, an extensive range of functions as well as an excellent price-to-performance ratio represent the salient features of this drive system.

Product features in terms of the technical applications are:

- universal implementation
- lower total costs
- digital drive concept
- highly dynamic operation
- cost-effective direct connection to the power connection
- software travel limit switch
- absolute or incremental position detection
- absolute or incremental position output
- integrated holding brake control
- increased operating safety
- adjustable error response
- automatic parameter matching
- easy startup operation

## 1.2 Overview of the functions

The functions of the digital, intelligent drive system are differentiated primarily according to the interface of the higher-level control. The fields of application for the ECODRIVE drive controllers vary accordingly.

The drive controller **DKC01.1** is used as a:

- servodrive with integrated position control
- servodrive with analog speed interface and integrated actual position detection
- servodrive with stepper interface.
- servodrive with electronic gearbox function

The drive controller **DKC11.1** represents a particularly cost-effective solution. It is used as a:

- servodrive with analog speed interface and integrated actual position detection

## Servodrive with integrated position control

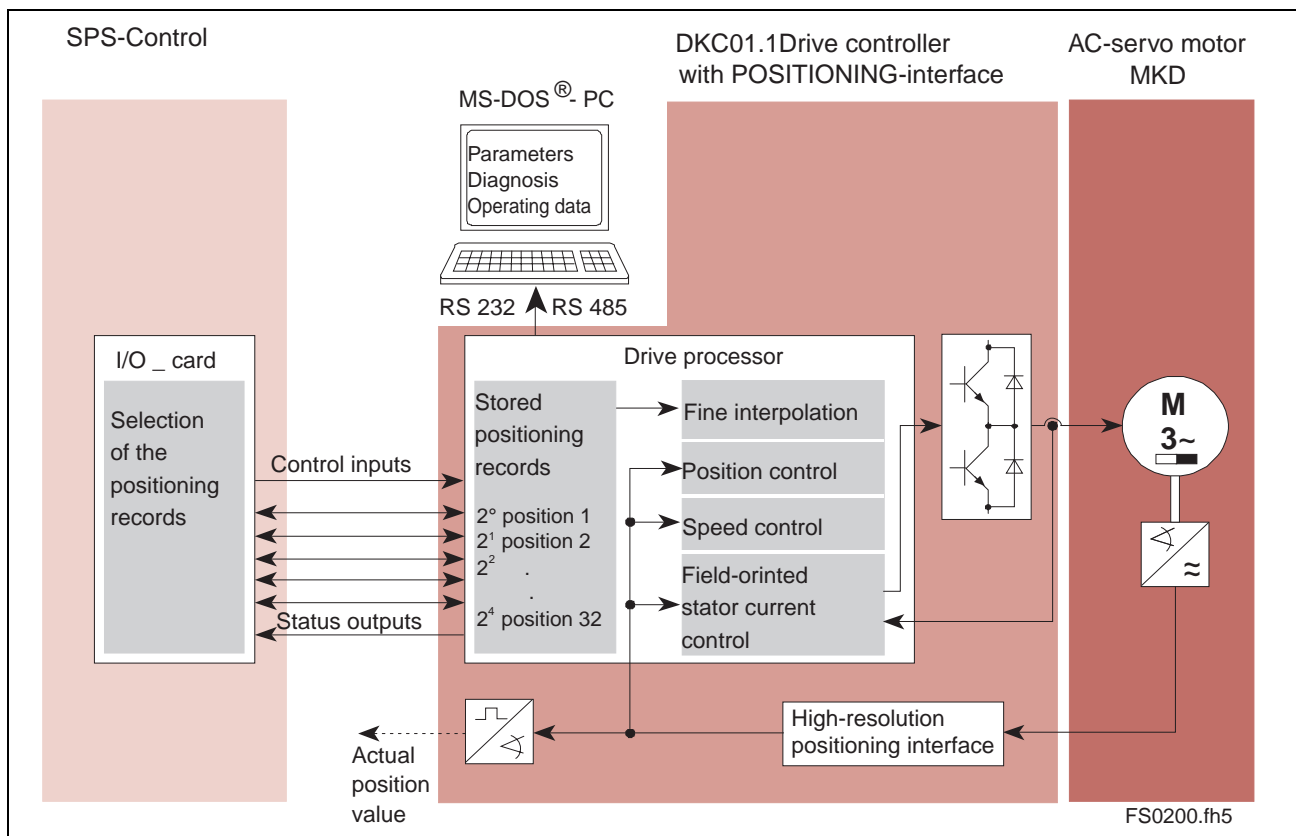

Fig. 1-1: Servodrive with integrated position control

- Up to 32 positioning blocks can be stored in the drive controller and selected over parallel inputs. The positioning block is executed autonomously.
- Mechanical translatory elements such as gear ratios or feed constants are adapted in the drive.
- All position, speed, and acceleration data can be weighted independently of the axis kinematics.
- A drive-internal referencing procedure is available for creating a reference dimension.
- The axis can be moved with the jog function during setup operation.
- The positioning speed can be influenced via the feedrate override.
- Travel limit switch inputs and axis limit values which can be parameterized are available for limiting the travel range.
- The drive status can be detected via status outputs.

### Servodrive with analog speed interface and integrated actual position detection

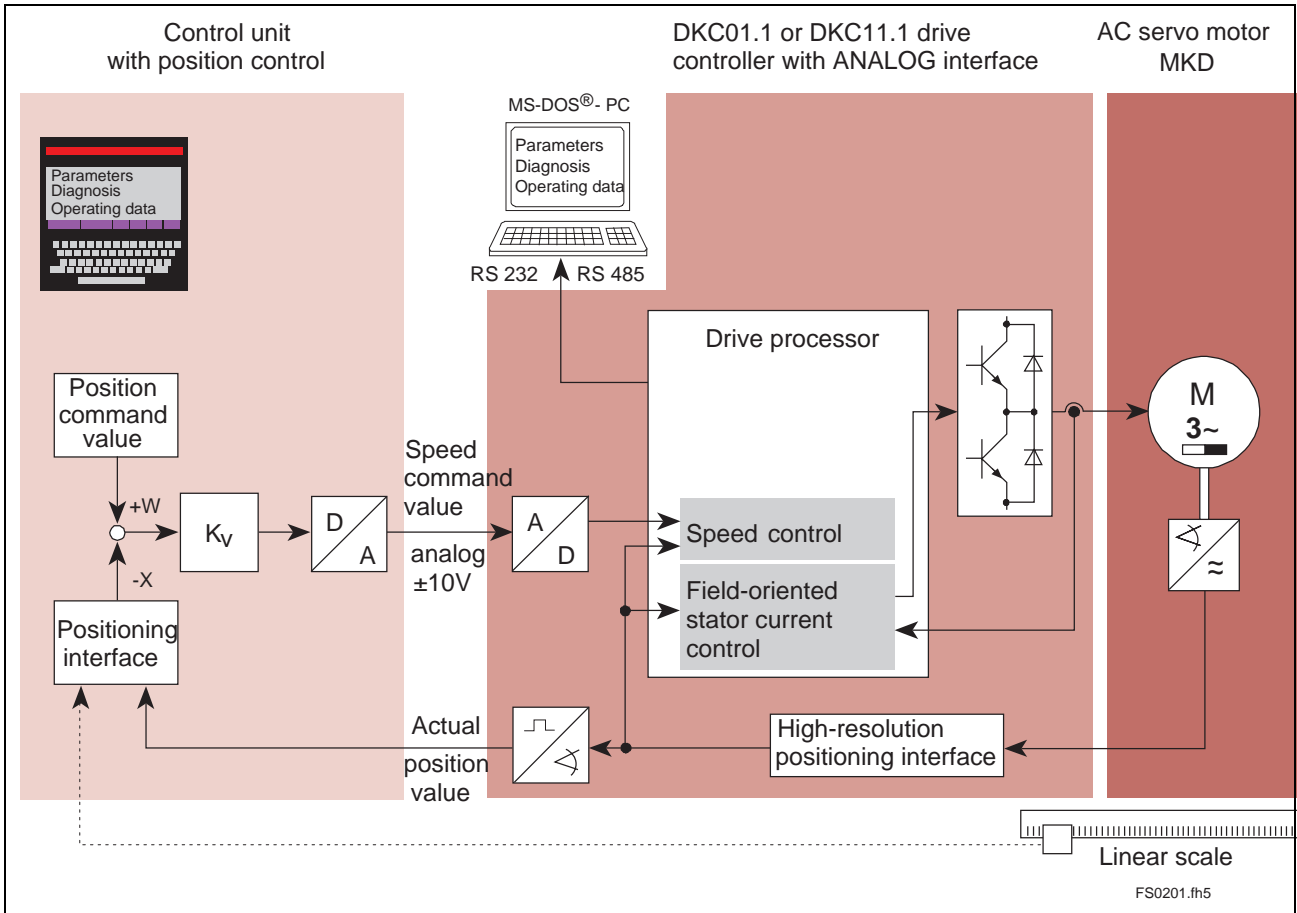

Fig. 1-2: Servodrive with analog speed interface and integrated actual position detection

- The analog speed command value can be set to any value.
- The actual position value is output either incrementally or absolutely.
- Using a switching input, the drive can be shut down independent of the command value and stopped free of drift during active control.

## Servodrive with stepper interface

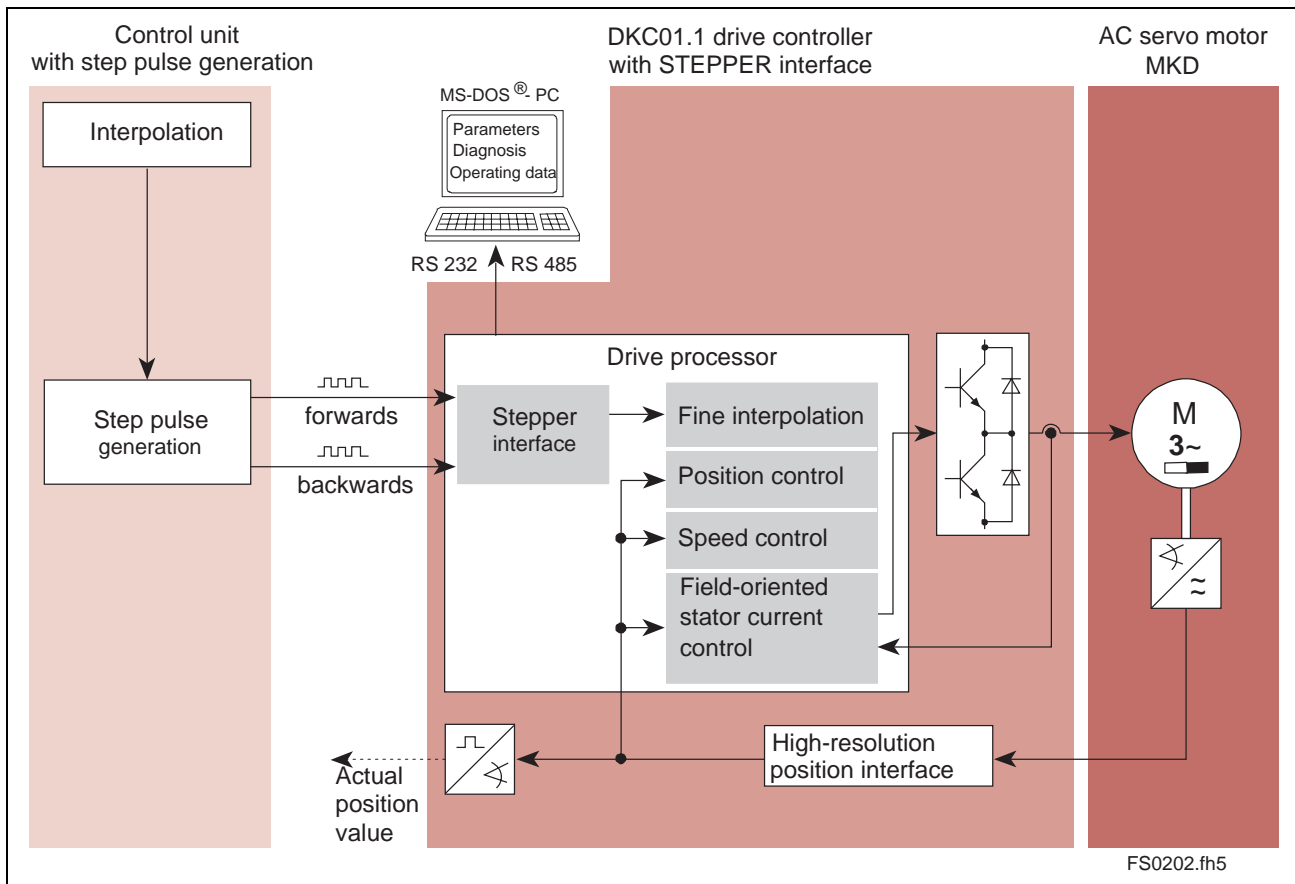

Fig. 1-3: Servodrive with stepper interface

- The number of steps per rotor rotation can be set to any value between 16 and 65536.
- The maximum step frequency is independent of the load. It is technically impossible to "skip" steps due to the position controlled operation.
- The stepper interface can be set to three standard signal definitions for exchanging signals between the control and the drive controller.
  - quadrature signals
  - forwards/backwards signals
  - step and direction signal
- A drive-internal referencing procedure is available for creating a reference dimension.
- The axis can be moved with the jog function during setup operation.
- The referencing and jog speed can be influenced via the feedrate override.
- Travel limit switch inputs and axis limit values which can be parameterized are available for limiting the travel range.

Servodrive with electronic gearbox function

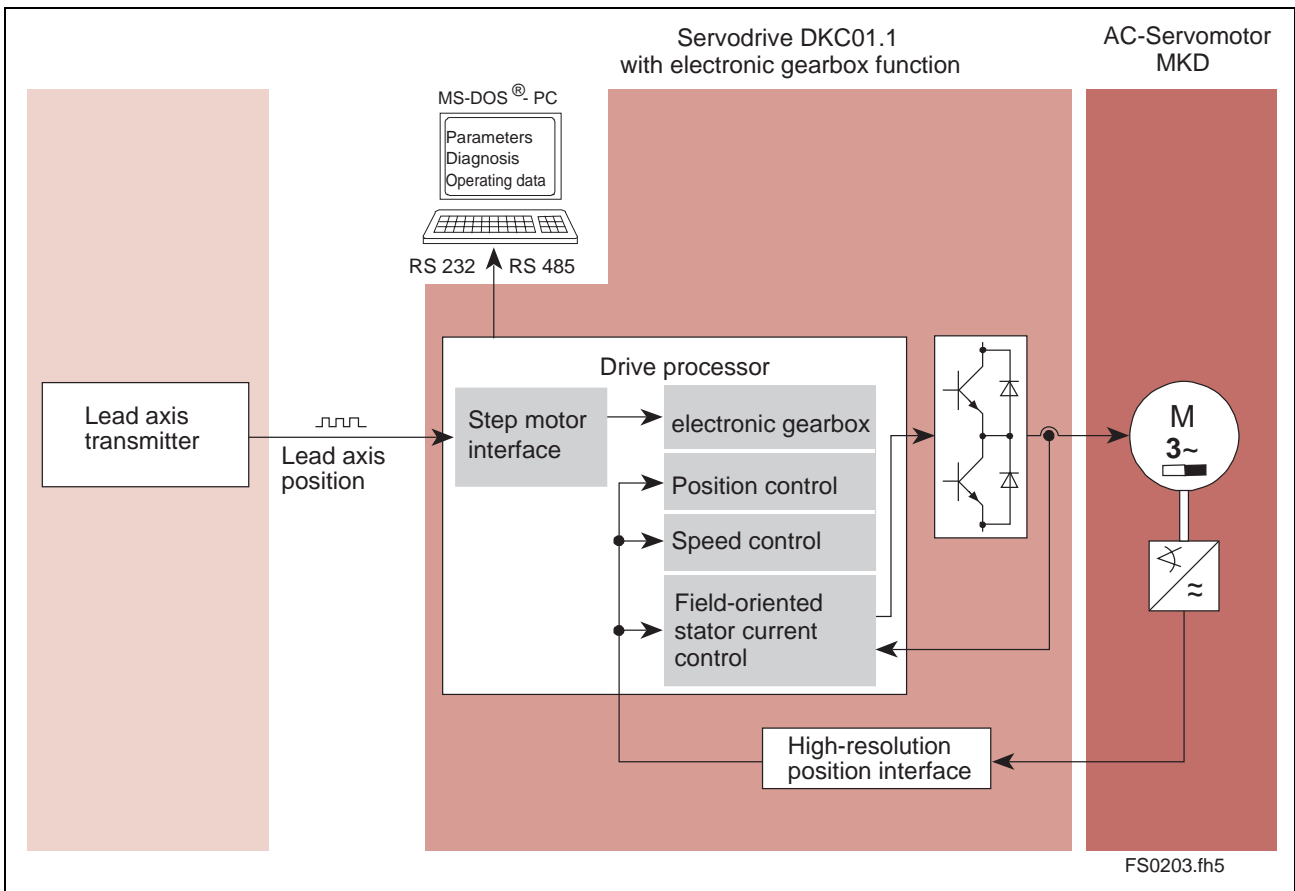

Fig. 1-4: Servodrive with electronic gearbox function

- Operating modes
  - Speed synchronization
  - Angle synchronization
- The lead axis position is given in degrees (360 degrees represent one lead axis encoder revolution)
- The lead axis encoder must be connected to the DKC stepper interface.

The maximum allowable signal frequency  $f_{max}$  on the stepper interface limits the number of lines  $Z_1$  which can be emulated.

## Notes

## 2 Safety instructions for electrical drives

Please read the following instructions carefully before initial startup. These safety instructions must be observed at all times.

If the product is transferred to a third-party, the safety instructions must be included.



**WARNING**

**Improper use of this equipment and non-compliance with the safety instructions provided can result in damage, personal injury or, in extreme cases, death.**

### 2.1 General

INDRAMAT GmbH is not liable for any damages resulting from failure to observe the safety instructions in this document.

- Documentation in the relevant national language should be obtained before initial startup if the language in this documentation is not perfectly understood.
- Proper transport, correct storage, assembly, and installation as well as care in operation and maintenance are prerequisites for optimum and safe operation of this equipment.
- Qualified personnel:

Only qualified personnel should be permitted to operate this equipment or work in its immediate vicinity. Personnel is considered qualified if it has sufficient knowledge of the assembly, installation, and operation of the product as well as all warnings and precautionary measures in this documentation.

Furthermore, personnel should be trained, instructed or authorized to switch electrical circuits on and off and to ground and mark them in accordance with the requirements of safety engineering. Personnel should possess adequate safety equipment and be trained in first aid.

- Use only replacement parts approved by the manufacturer.
- All safety regulations and requirements for the specific application must be followed.
- The equipment is designed to be installed in machines for commercial use.
- Startup is only permitted once it is sure that the machine in which the products are installed complies with the requirements of the national safety regulations and safety specifications of the application. European countries: EC Directive 89/392/EEC (Machine Guideline)
- Operation is only permitted if the national EMC regulations for the specific application have been met. European countries: EC Directive 89/336/EEC (EMC Guideline)

The instructions for installation in accordance with EMC requirements can be found in the document "EMC Drive and Control Systems."

The responsibility for adherence to the limiting values required by national regulations lies with the manufacturer of the equipment or machine.

- Technical specifications as well as the connection and installation requirements can be found in the product documentation and must be observed under all circumstances.

## 2.2 Protection against contact with electrical parts

---

**Note:** Only relevant for devices and drive components with voltages exceeding 50 volts.

---

Coming into contact with components carrying voltages greater than 50 volts can be dangerous. Certain parts are under dangerous voltage when operating electrical devices.

---



**DANGER**

### High Voltage!

Danger to life or risk of bodily injury!

- ⇒ Follow general construction and safety regulations when working on electrical installations.
  - ⇒ Before switching on power, be sure that the ground wire is permanently connected to all electrical units according to the connection diagram.
  - ⇒ At no time may electrical equipment be operated if the ground wire is not permanently connected to the proper terminals, even for brief measurements or tests.
  - ⇒ Disconnect the equipment from the power supply line or the voltage source before beginning work. Secure equipment from reclosure.
  - ⇒ Wait 5 minutes after switching off power to allow capacitors to discharge before using the equipment. Measure the voltage of the capacitors before beginning work in order to eliminate dangers arising from touching components.
  - ⇒ Never touch the electrical connection points of a component while the power is turned on.
  - ⇒ Cover live parts properly before switching the equipment on so they cannot be touched. Covers provided with the equipment must be installed before operating the equipment to prevent contact with live parts. The equipment may only be operated with the covers designed for shock-hazard protection.
  - ⇒ A GFCI protective device (ground fault circuit interrupter) cannot be used for AC drives! Protection against indirect contact must be ensured by other means, for example, by using an overcurrent protection device in accordance with relevant standards. European countries: in accordance with EN 50178/1994, section 5.3.2.3
  - ⇒ For installation equipment protection against indirect contact must be ensured using an external housing, such as a control cabinet. European countries: in accordance with EN 50178/1994, section 5.3.2.3
-



**High discharge current!**

Danger to life or risk of bodily injury!

- ⇒ All units and the motors must first be connected to a grounding point with the ground wire or must be grounded themselves before switching on power.
- ⇒ The discharge current is greater than 3.5 mA. A permanent connection to the power supply line is therefore required for all units. European countries (EN 50178/1994, section 5.3.2.3)
- ⇒ Before startup operation always connect the protective conductor or the ground conductor. Otherwise the housing may harbor high voltages.

## 2.3 Protection against shocks caused by safety extra-low voltage (SELV)

All connectors and terminals on INDRAMAT products with voltages from 5 to 50 volts are safety extra-low voltages offering a shockproof design to meet the following standards:

- international: IEC 364-4-411.1.5
- European countries in the EC: EN 50178/1994, section 5.2.8.1

**High electrical voltages due to incorrect connections!**

Danger to life or risk of bodily injury!

- ⇒ Only equipment and lines carrying protective extra low voltage (PELV) may be connected to connectors and terminals with voltages ranging from 0 to 50 volts.
- ⇒ Connect only voltages and circuits safely isolated from dangerous voltages. Isolation can be achieved, for example, by using safe isolation transformers, optocouplers or power supply independent battery operation.

## 2.4 Protection against dangerous movements

Dangerous movements can be caused if the connected motors are not controlled correctly.

There are various causes of dangerous movements:

- faulty wiring or cable connections
- operating the components improperly
- defective measured value transmitters and primary detectors
- defective components
- errors in the software

These errors can occur just after the equipment has been switched on or after an indefinite period of time.

The monitors in the drive components virtually exclude failure in the connected drives. However, personnel safety requires that additional measures be taken to ensure correct operation. Faulty drive motions which are influenced by the type of control and the operating status cannot be entirely excluded until the installed monitors take effect.

**DANGER****Dangerous movements!**

Danger may result in equipment damage, personal injury or death!

⇒ Personal safety must be ensured by higher-level, monitoring at the installation or precautionary measures for the reasons listed above. These are provided by the plant manufacturer according to the specific conditions of the plant based on a danger and malfunction analysis. The safety regulations in effect for the plant are included herein.

**Avoiding accidents:**

- ⇒ Stay away from the machine's movement area. Possible measures to be taken to prevent access by unauthorized persons:
  - protective fence
  - protective railing
  - protective covering
  - light barrier
- ⇒ Fences and coverings should be strong enough to withstand the maximum possible momentum.
- ⇒ Mount the emergency stop switch (E-stop) at an easily accessible place in the immediate vicinity. Verify that the E-stop switch works before starting operation.
- ⇒ Isolate the drive power connection by means of an E-stop circuit or use a starting lock-out to prevent unintentional startup.
- ⇒ Make sure that the drives have been shut down before accessing or entering the danger zone.
- ⇒ Disable electrical power to the equipment using a master switch and secure against reclosure during:
  - maintenance and repair work
  - equipment cleaning
  - long downtime periods
- ⇒ Avoid operating high-frequency, remote control, and radio equipment near electrical equipment and their supply leads. If the use of such equipment cannot be avoided, verify that the system and plant are in perfect working order in all working situations before initial operation. If necessary, the plant must undergo special EMC testing.

## 2.5 Protection against magnetic and electromagnetic fields during operation and assembly

Magnetic and electromagnetic fields near current-carrying conductors and permanent magnets pose a serious health hazard for persons with pacemakers, metal implants and hearing aids.



**WARNING**

---

**Health hazard for persons with pacemakers, metal implants and hearing aids in the immediate vicinity of electrical equipment.**

⇒ Persons with pacemakers and metal implants must not be permitted access to the following areas:

- Areas in which electrical equipment and parts are mounted, operated or put into operation.
- Areas in which motor parts with permanent magnets are stored, repaired or mounted.

⇒ If it becomes necessary for a person with a pacemaker to enter such an area, this must be approved by a physician beforehand.

Implanted pacemakers or those to be implanted have a varying degrees of resistance to interference, making it impossible to establish any general guidelines.

⇒ Persons with metal implants or metal splitters as well as hearing aids should consult a physician before entering such areas since they represent a health hazard.

---

## 2.6 Protection during handling and assembly

Handling or assembling drive components improperly may lead to personal injury.



**CAUTION**

### Risk of injury due to improper handling!

Bodily injury may be caused by crushing, shearing, cutting, and pounding forces.

- ⇒ Observe general construction and safety regulations when working on electrical installations.
- ⇒ Use suitable assembly and transport equipment.
- ⇒ Take precautions to prevent pinching and crushing.
- ⇒ Use only suitable tools. Use special tools as prescribed.
- ⇒ Employ lifting devices and tools according to the manufacturers' instructions.
- ⇒ If necessary, use suitable protective equipment (for example goggles, safety shoes, protective gloves).
- ⇒ Do not stand under suspended loads.
- ⇒ Remove any leaking liquids on the floor immediately to prevent slipping.

## 2.7 Safe battery usage

Batteries consist of reactive chemicals contained in a solid case. Improper use can therefore lead to injuries or equipment damage.



**CAUTION**

### Risk of injury due to improper handling!

- ⇒ Do not attempt to reactivate empty batteries by heating them or by any other means (danger of explosion or corrosion).
- ⇒ Do not recharge batteries because they may leak or explode.
- ⇒ Do not dispose of batteries by throwing them into a fire.
- ⇒ Do not attempt to disassemble batteries.
- ⇒ Do not damage the electrical components installed in the equipment.

**Note:** Environmental protection and disposal! The batteries contained in the product are considered hazardous material for land, sea, and air transport according to the legal regulations (danger of explosion). Dispose used batteries separately from other waste. Observe the national regulations in the country of installation.

## Notes

### 3 Selecting the components

#### 3.1 Overview of the required components

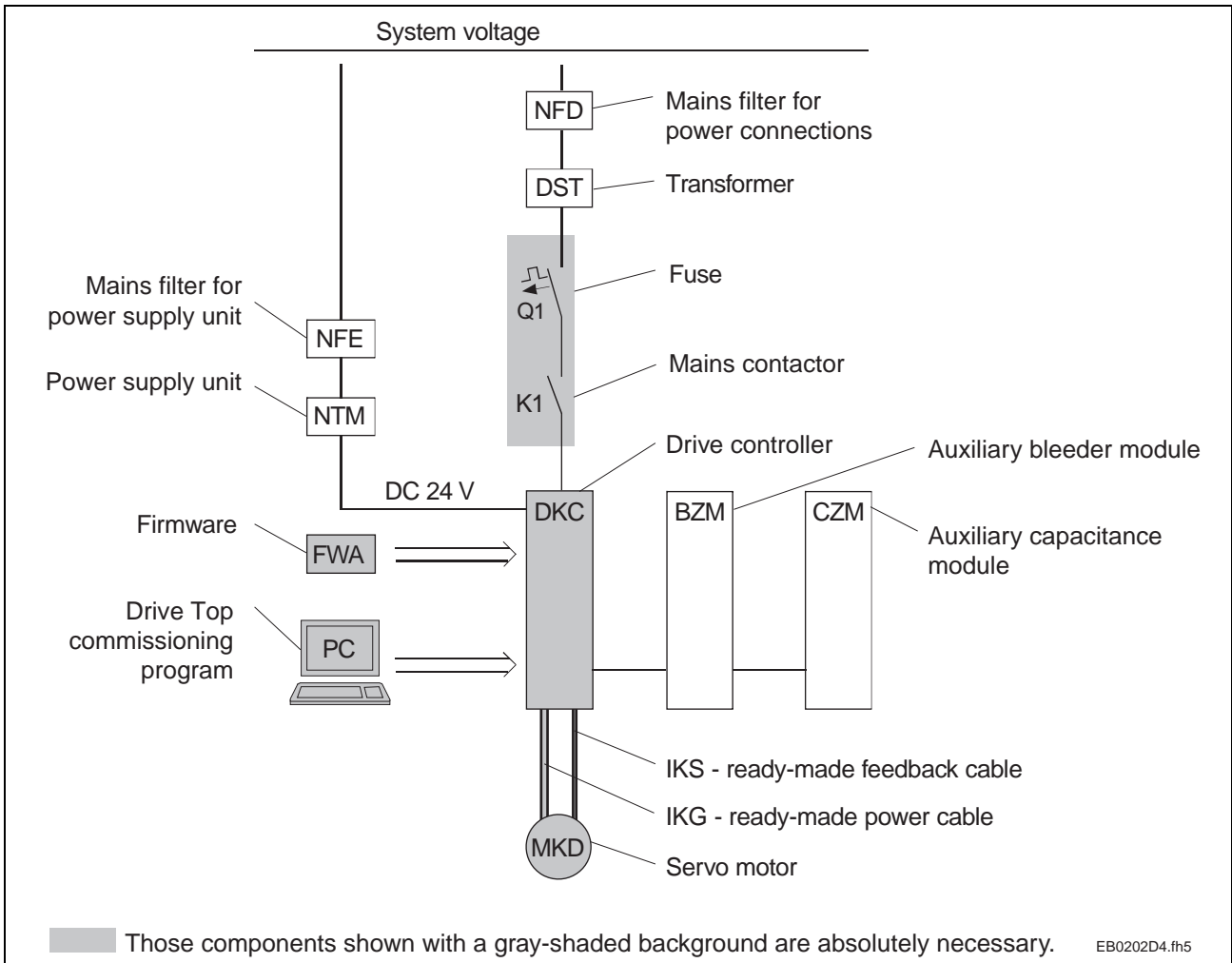

Fig. 3-1: Overview of the required components

## 3.2 Selection procedure

- Dimensioning and selecting the servo drive**
- ⇒ Dimension the drive according to how it is to be used. A document for this is under preparation.
  - ⇒ Select motor/drive combination (DKC + MKD) using the "Selection Data" documentation (see pg. 3, supplementary documentation)."
- Compiling the required data**
- ⇒ Enter the values obtained from dimensioning and enter the drives selected into table Fig. 3-2 .
  - ⇒ Calculate the continuous regenerative power according to the specifications in Chapter 5 and enter them in table Fig. 3-2 .
- Selecting the required components**
- ⇒ Use firmware "FWA-ECODRV-ASE-02VRS-MS" for DKC01.1-\*\*\* and DKC11.1-\*\*\* (no selection required at this time)
  - ⇒ "Select ready-made cables for the connection between the DKC and MKD by using the document "MKD Servomotors - Project Planning Manual" (see pg. 3 of supplementary documentation)."
  - ⇒ Select fuse protector Q1 (see Chapter 11.2).
  - ⇒ Select line contactor K1 (see Chapter 11.2).
- Determining components which may be additionally required**
- ⇒ Check the rated line voltage.
    - If, in the case of the DKC\*\*.\*-040-7, the rated line voltage falls below or exceeds 3xAC (380-460)V  $\pm 10\%$ , select a DST transformer (see Chap. 9.2).
    - If, in the case of the DKC\*\*.\*-030-3, the rated line voltage falls below or exceeds 3xAC230V  $\pm 10\%$ , select a DST transformer (see Chap. 9.3).
  - ⇒ Check the DC24V control voltage supply for the DKC. If a voltage of DC24 Volt  $\pm 20\%$  is not available, select a suitable NTM power supply (see Chap. 7).
  - ⇒ Check the DC24V voltage for the motor holding brake. If a voltage of DC24 Volt  $\pm 10\%$  is not available, then select a suitable NTM power supply (see Chap. 7).
  - ⇒ Check the continuous regenerative power. If it exceeds 0.15 kW, then consider option with BZM auxiliary bleeder module (see Chap. 5).
  - ⇒ Check the peak regenerative power. If it exceeds 5 kW, then consider option with DKC\*\*.\*-040-7 and if needed, the BZM auxiliary bleeder module (see chapter 5).
  - ⇒ If the continuous regenerative power exceeds approx. 0.1 kW and the drive system energy content is less than 200W, the use of an auxiliary capacitance module CZM can be economical. This makes it possible to reduce the dissipated energy for the control cabinet by an amount equal to the continuous regenerative power (see Chap. 6).
  - ⇒ Check the EMC conditions. INDRAMAT recommends the use of NFD or NFE mains filters to maintain EMC limiting values (see Chap. 8).



### 3.3 Compiling the required data

Designation	Symbol	Values/Units
Effective load torque	$M_{EFF}$	..... in Nm
Acceleration torque	$M_{ACC}$	..... in Nm
Operating torque	$M_{BEARB}$	..... in Nm
Motor speed used	$n_{NUTZ}$	..... in min-1
Load moment of inertia	$J_{LAST}$	..... in kgm <sup>2</sup>
Maximum rotary energy in the mechanical system (E-stop case)	$W_{ROT,MAX}$	..... in Ws
Continuous regenerative power	$P_{RD}$	..... in kW
Continuous torque at standstill	$M_{DN}$	..... in Nm
Maximum torque	$M_{MAX}$	..... in Nm
Short-term operation torque	$M_{KB}$	..... in Nm
Maximum motor speed	$n_{MAX}$	..... in min-1
Required power connection output	$S_{AN}$	..... in kVA
Required mains rated voltage	$U_N$	..... in V
Motor/controller combination		DKC..... MKD.....
Motor moment of inertia	$J_M$	..... in kgm <sup>2</sup>
DKC current consumption	$I_{N,DC}$	0.7 in A
Power consumption of the motor holding brake (if present) refer to the project planning manual MKD Motors	$I_{N,HB}$	..... in A

Fig. 3-2: Data required for selecting the components

## Notes

# 4 ECODRIVE DKC drive controllers

## 4.1 Hardware

### View of unit

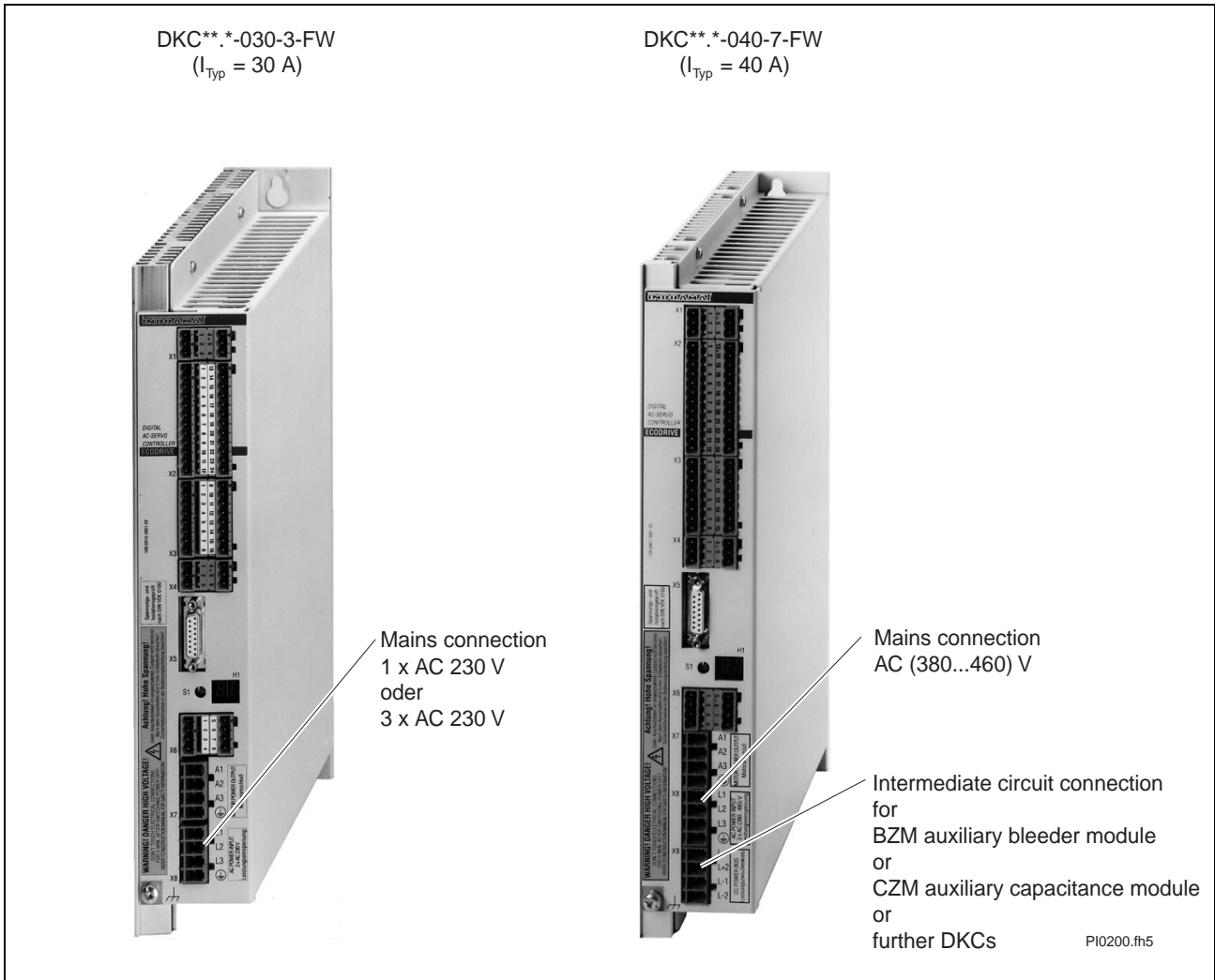

Fig. 4-1: Main distinguishing hardware features of the DKC controllers

### Dimensional sheets and installation dimensions

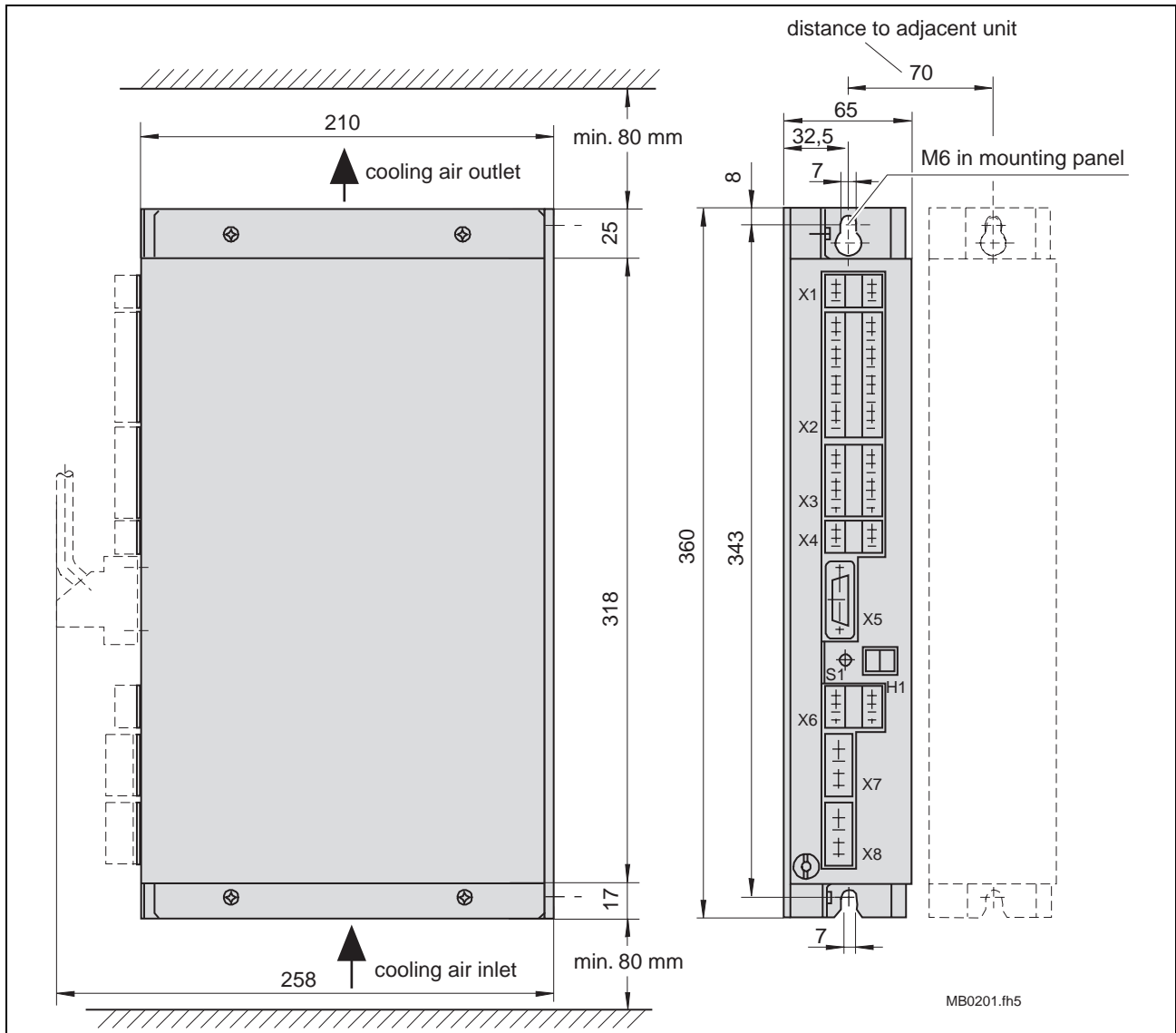

Fig. 4-2: Dimensional data and installation dimensions DKC01.1-030-3-FW

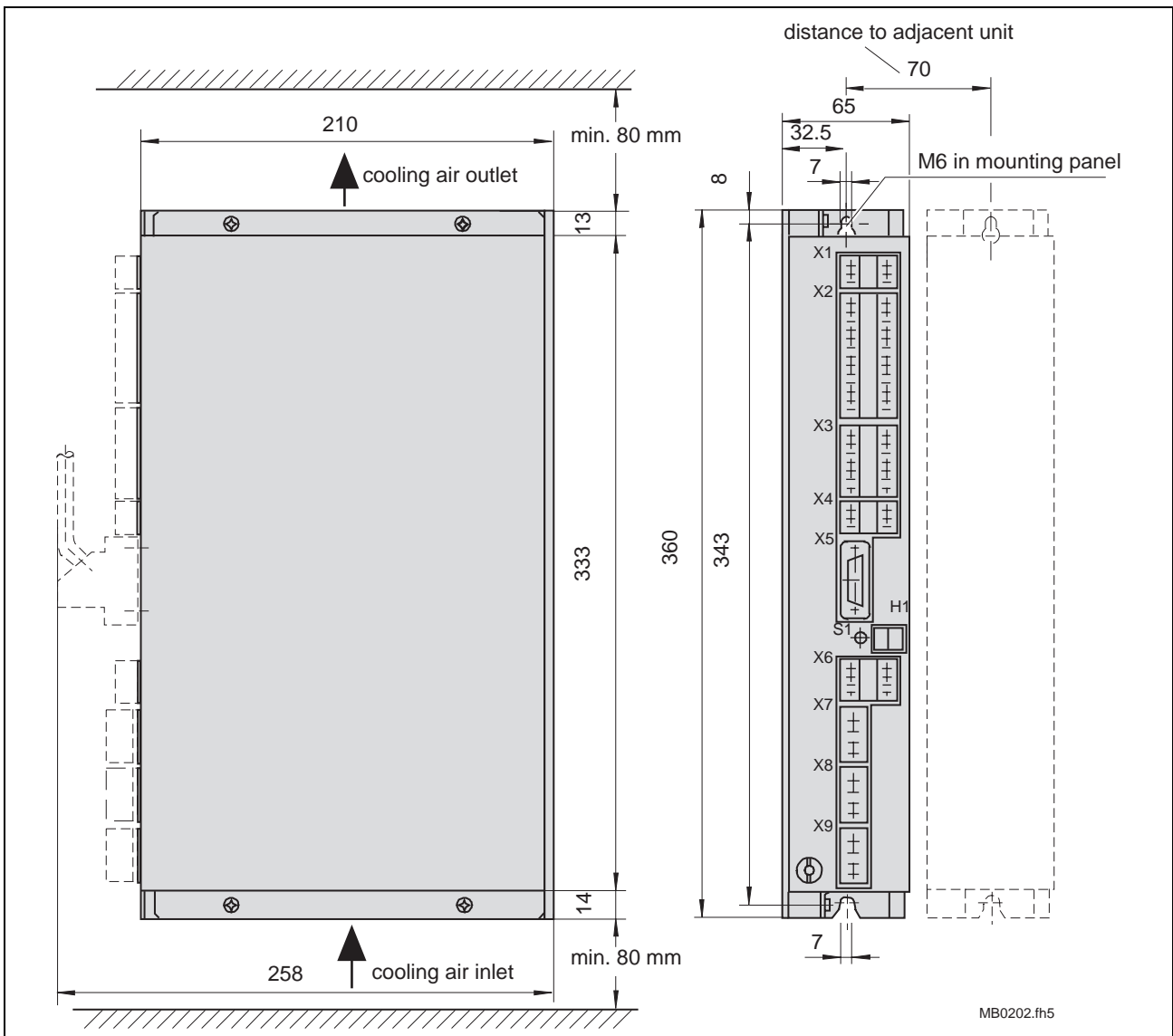

Fig. 4-3: Dimensional data and installation dimensions DKC01.1-040-7-FW/DKC11.1-040-7-FW

## Technical data

### Power connection / Power section

Designation	Symbol	Unit	DKC01.1-030-3-FW		DKC**.1-040-7-FW
			single-phase	three-phase	three-phase
Operating mode at the mains			single-phase	three-phase	three-phase
Mains input voltage	$U_N$	V	1 x AC 230 ± 10%	3 x AC 230 ± 10%	3 x AC (380 ... 480) ± 10%
Maximum conn. voltage	$S_{MAX}$	kVA	1,8	3,2	4,8 ... 9
Making current	$I_{EIN}$	A	10	10	9 ... 12
Mains frequency	$f_N$	Hz	50...60		
Switching frequency (selectable)	$f_S$	kHz	4 or 8		4 or 8
Continuous current at $f_S = 4$ kHz <sup>1)</sup>	$I_{CONT}$	A	12		16
Continuous current at $f_S = 8$ kHz <sup>1)</sup>	$I_{CONT}$	A	11		12,5
Rated current	$I_{TYP}$	A	30		40
Peak current	$I_{PEAK}$	A	30		40
Power dissipation, without bleeder dissipation	$P_V$	W	100		180
Peak bleeder output DKC	$P_{BM,DKC}$	kW	5 (for 1 s)		10 (for 0,5 s)
Continuous bleeder output DKC	$P_{BD,DKC}$	kW	0,15		0,15
Maximum feedback energy DKC	$W_{MAX,DKC}$	kWs	5,0		5,0
Storage energy DKC	$W_{ZW,DKC}$	Ws	15		15
DC bus capacitance	$C_{DKC}$	mF	0,15		0,15
DC bus voltage <sup>2)</sup>	$U_{ZW}$	V	not lead to the outside		DC 500...800

1) The drive data for 4 and 8 kHz switching. frequencies are listed in the document "ECODRIVE DKC servo drive" - Selection Data.  
2) Value dependent on power input voltage

TB0202.fh5

Fig. 4-4: Technical data for the power connection and power section

### DC24V Power supply

Designation	Symbol	Unit	DKC01.1-030-3-FW	DKC**.1-040-7-FW
Control voltage connection for DKC				
Input voltage	$U_{N,DC}$	V	DC (19,2 ... 28,8) V	
Maximum ripple content	w	%	must not exceed the input voltage range	
Current consumption	$I_{N,DC}$	A	0,7	
<b>Voltage connection for holding brake</b>				
Input voltage	$U_{N,HB}$	V	DC 24 ± 10%	
Maximum ripple content	w	%	must not exceed the input voltage range	
Current consumption	$I_{N,HB}$	A	please see MKD dokumentation	

TB0203.fh5

Fig. 4-5: Technical data for the DC24V power supply

**Additional connection of the DC24 power supply**

The DKC drives should be firmly connected to the DC24V power supply; preferred method Fig. 4-6

They can also be connected to the DC24V power supply in a switchable manner Fig. 4-7

**Preferred method:  
The power supply is firmly  
connected to the attached DKC**

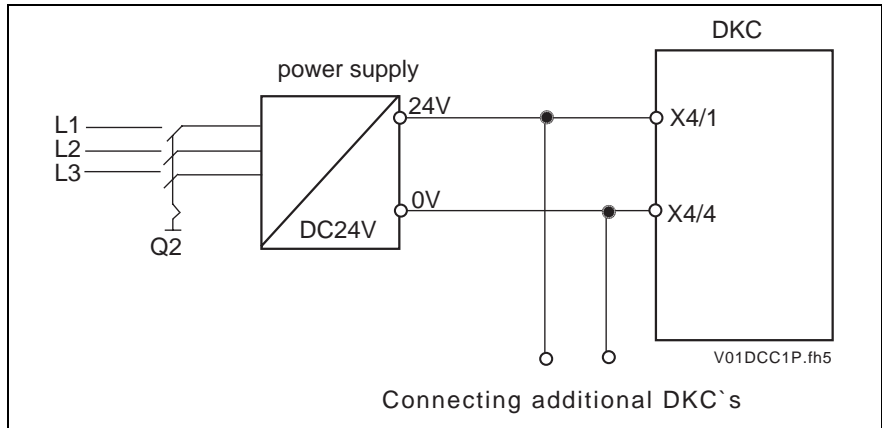

Fig. 4-6: Principle for connecting the DC24V control voltage by switching on the power supply via Q2, **preferred method**

**The power supply is connected  
to the attached DKC in a  
switchable manner**

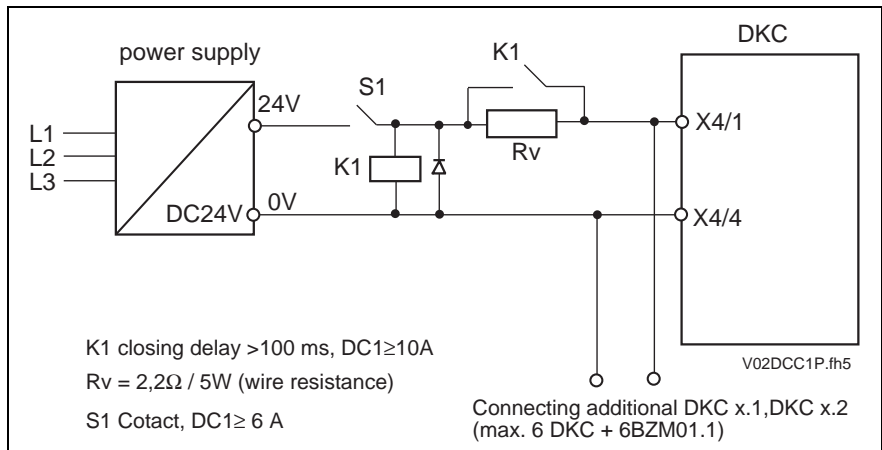

Fig. 4-7: Principle for connection the 24V via S1 with a starting current limiter

**Ambient and installation conditions**

**Ambient temperature and installation altitude**

Selection lists are specified for each motor/drive documentation. Please refer to the documentation "ECODRIVE Servodrives DKC with MKD - Selection Lists -

The selection lists apply within the given ambient and installation conditions (see Fig. 4-9).

For different conditions, the short-term operating torque is reduced according to the diagrams (see Fig. 4-8). If deviating ambient temperatures and higher installation altitudes occur simultaneously, both load factors must be multiplied.

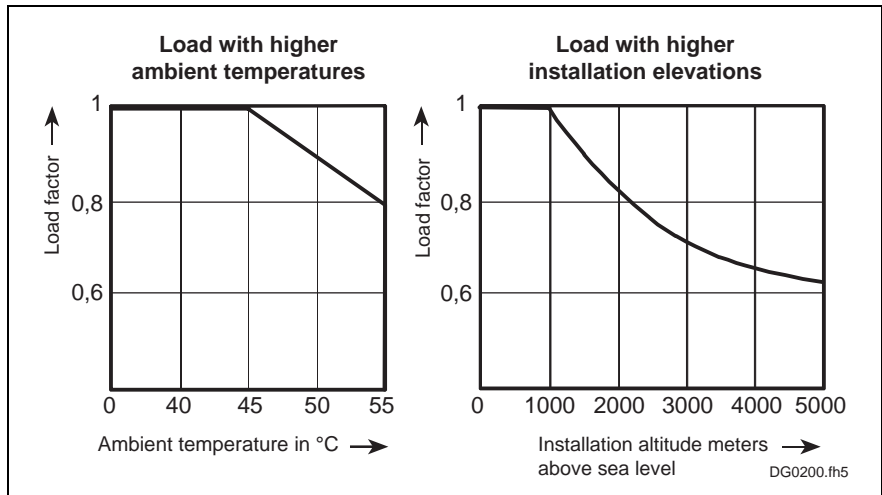

Fig. 4-8: Load utilization as a value dependent upon ambient temperature and installation altitude

Designation	Symbol	Unit	DKC01.1-030-3-FW	DKC** .1-040-7-FW
Ambient and installation conditions				
Cooling the power section			natural air cooling	internal blower cooling
Permissible ambient temperature with nominal data	$T_{UM}$	°C	+0...+45	
Max. permissible ambient temperature with reduced nominal data	$T_{UM,MAX}$	°C	+55 The values indicated in the selection data for $M_{DN}$ and $M_{KB}$ , drop in the range of +45 to +55°C by 2% per °C of rise in temperature.	
Storage and transport temperature	$T_L$	°C	-30...+85	
Max. installation elevation with nominal data		m	1000	
Max. permissible relative humidity		%	95	
Max. permissible absolute humidity		g/m <sup>3</sup>	25	
Degree of contamination	Non-conductive dirt contamination, no condensation			
Protection category	IP20, as per EN 60529 = DIN VDE 0470-1-1992 (IEC 529-1989) stationary use in control cabinets			
Weight	m	kg	4.4	

TB0204.fh5

Fig. 4-9: Ambient and installation conditions



## Type code and rating plate

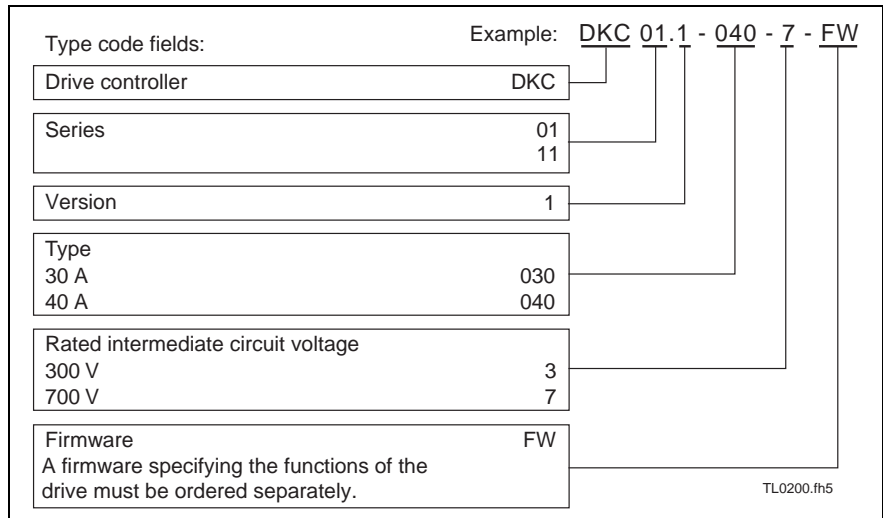

Fig. 4-10: DKC type code

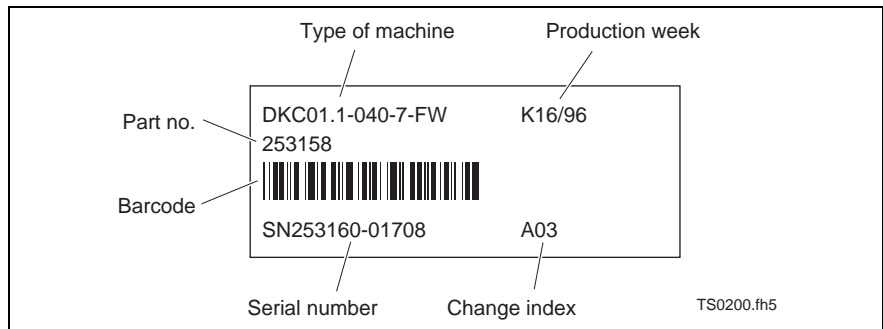

Fig. 4-11: DKC rating plate

## 4.2 Firmware

The firmware located in the drive controller determines the functional features of the ECODRIVE drive controller.

The firmware "FWA-ECODRV-ASE-02VRS-MS" is for the drive controllers DKC01.1-\*\*\* and DKC11.1-\*\*\*.

The firmware has its own order number. This means that it is always possible to order the identical firmware version.

The firmware is updated constantly to eliminate any bugs without altering the functionality. It is identified on the type code as the firmware release version.

If newer functions are added, the index of the firmware version is incremented (see type codes).

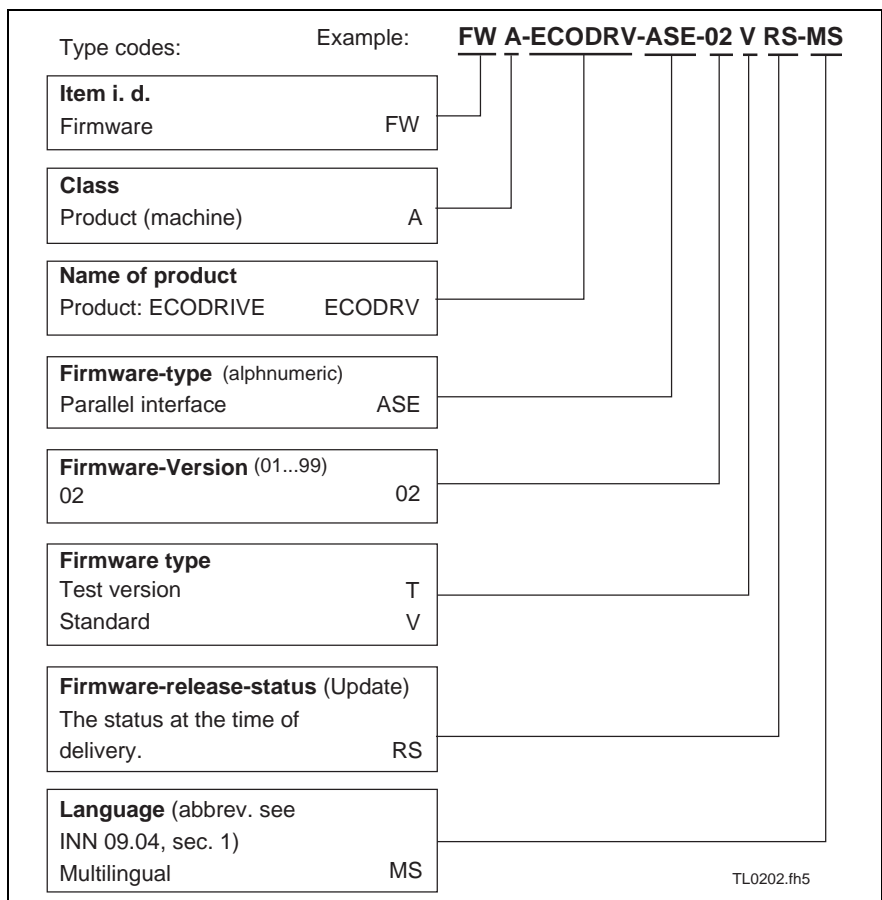

Fig. 4-12: ECODRIVE firmware type code

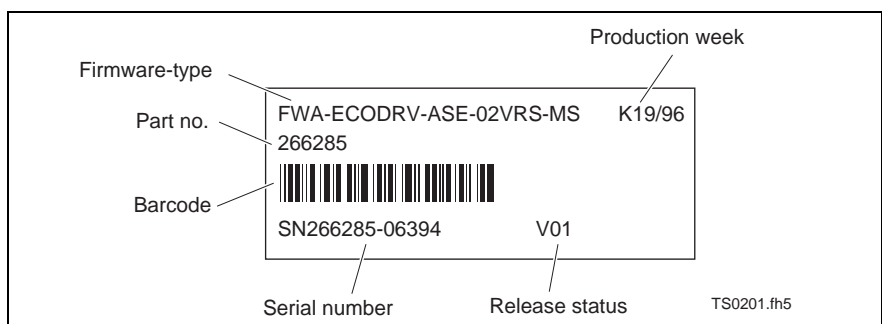

Fig. 4-13: Firmware rating plate

### 4.3 An overview of the electrical connections

#### Front view with supply terminals

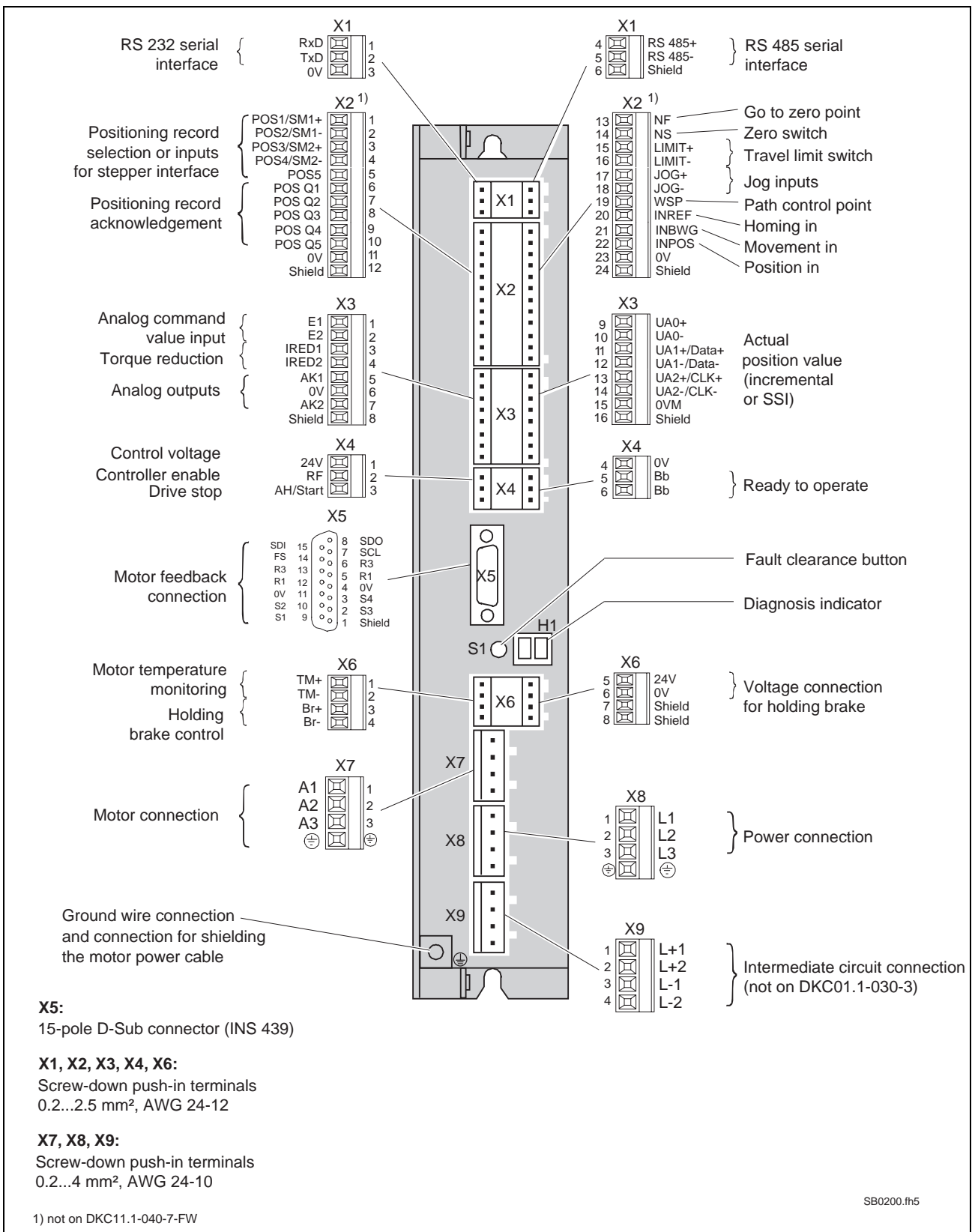

Fig.. 4-14: Front view of the DKC with supply terminals

### Overall connection diagrams

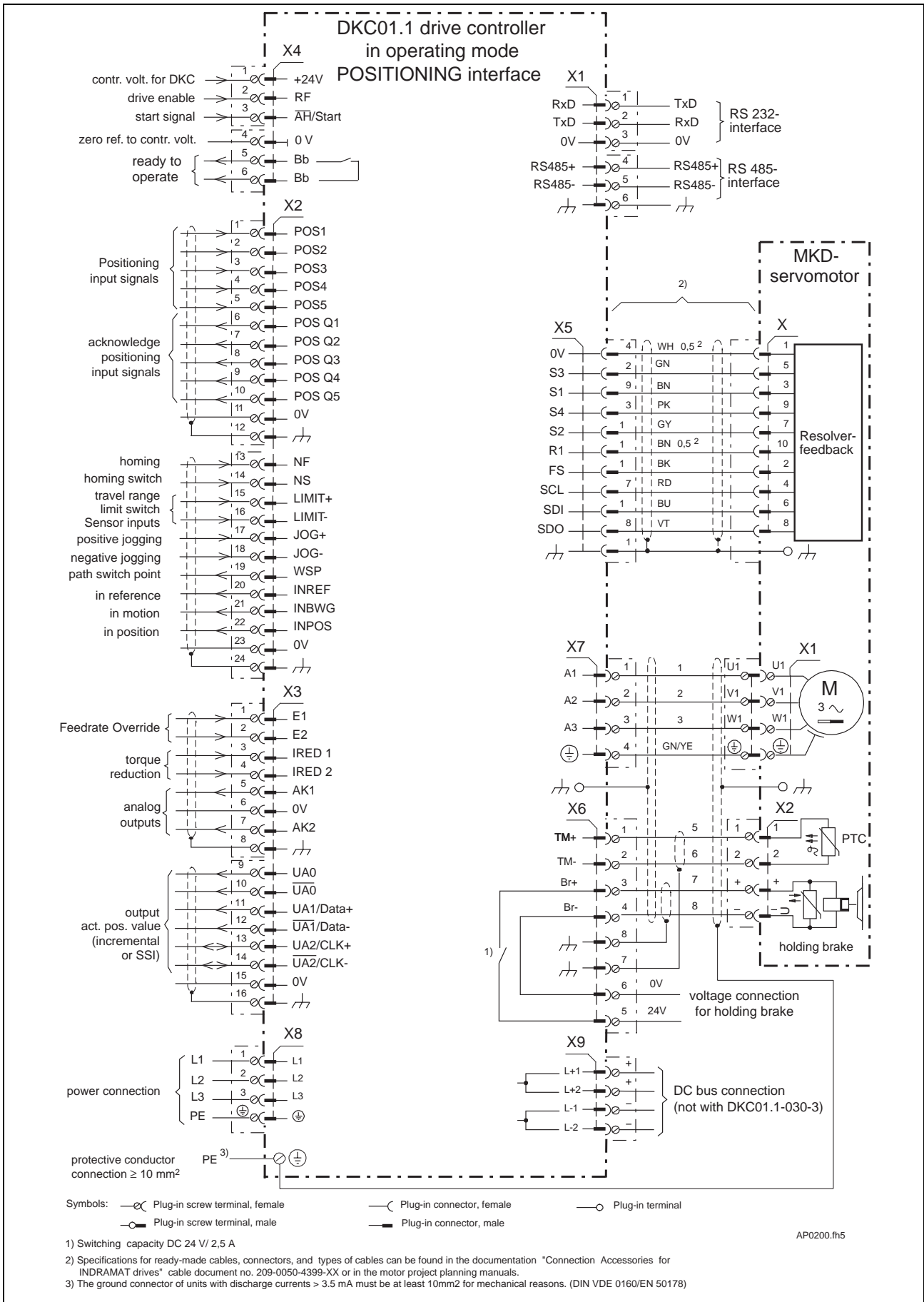

Fig. 4-15: DKC01.1 with POSITIONING interface

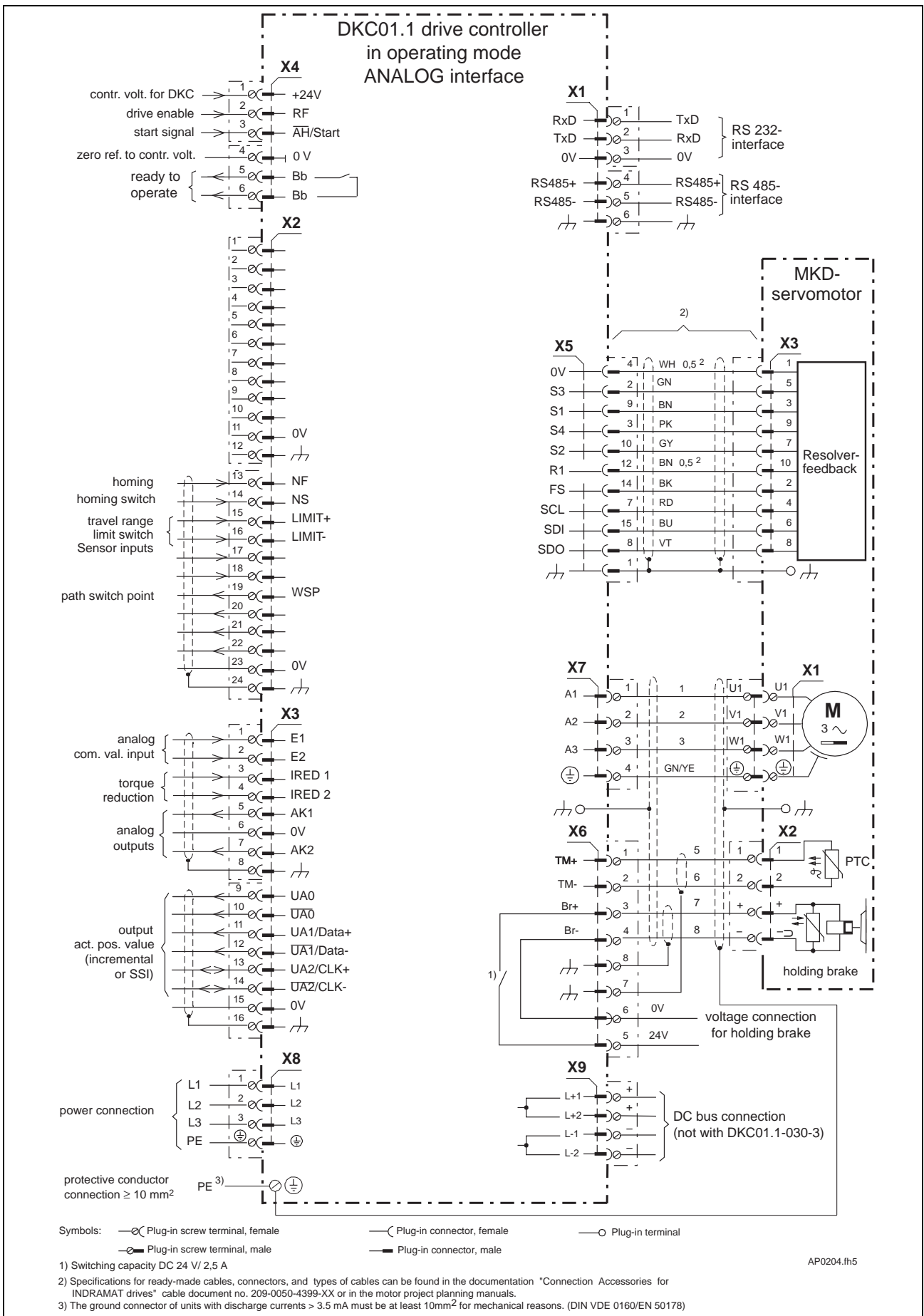

Fig. 4-16: DKC01.1 with ANALOG interface; Supply terminal assignment

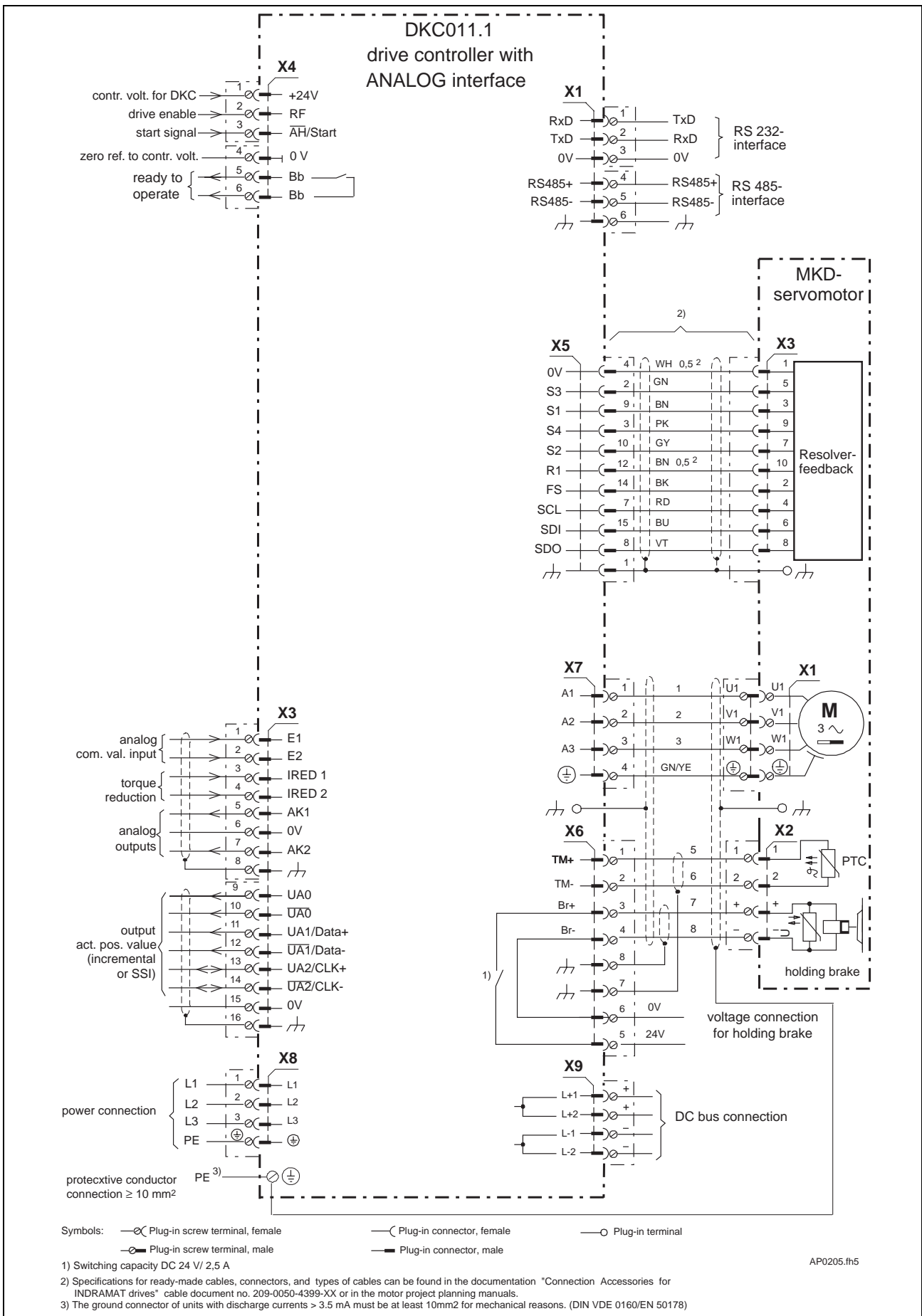

Fig. 4-17: DKC11.1-040-7-FW with ANALOG interface

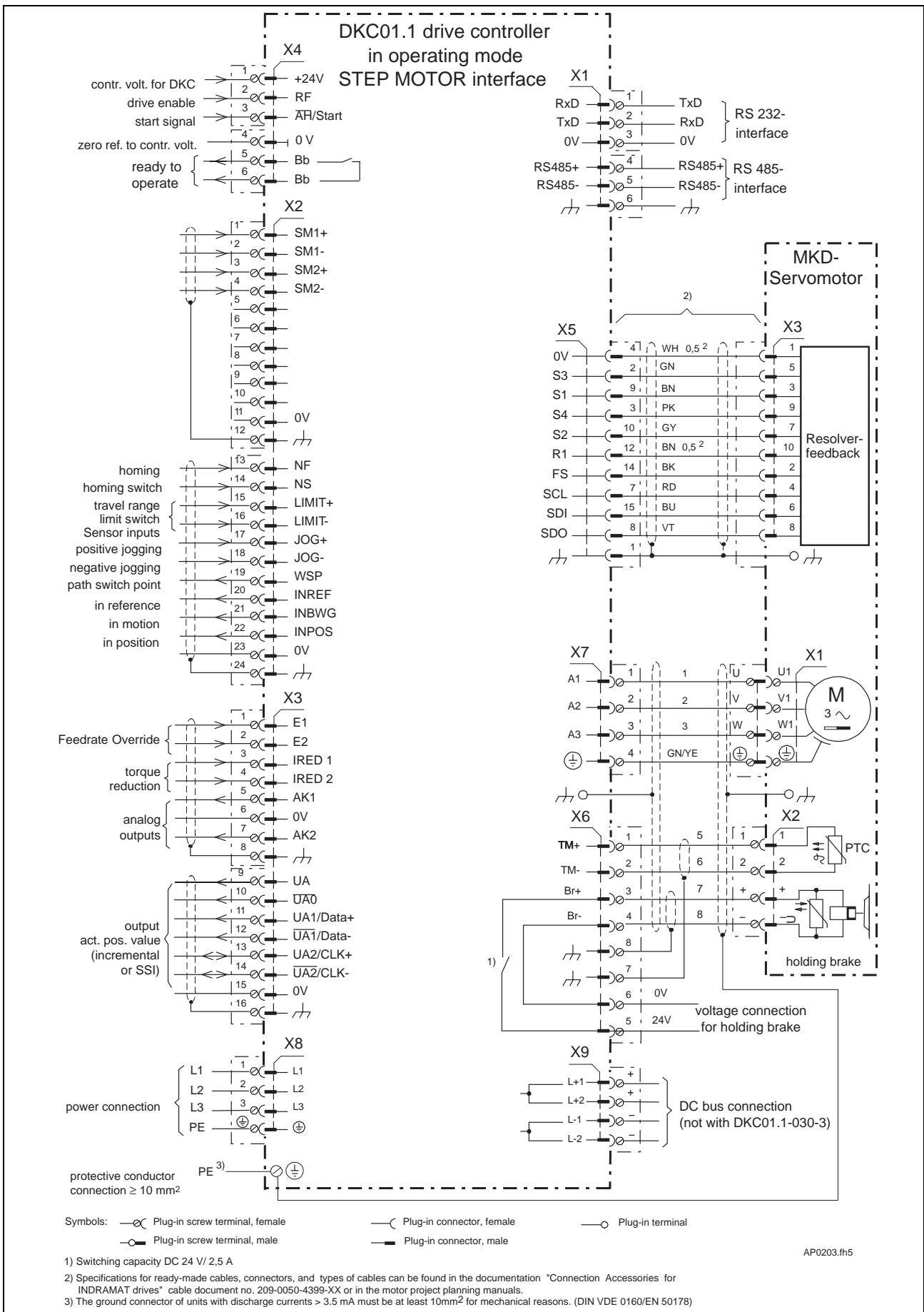

Fig. 4-18: DKC01.1 with stepping interface

## 4.4 Electrical connection to the supply terminal strips

The description of the electrical connections below are first grouped according to numbers of the supply terminal strips (e.g. X1, X2 etc.) and then according to the functions.

### Serial interface X1

The serial interface is generally used for programming, parameterization and diagnoses during startup operation and service procedures.

It can be alternatively operated as a RS 232 or RS 485.

#### RS-232 interface

The RS-232 interface is needed for programming, parameterizing and diagnosis during startup operation and service procedures.

It is also used when setting the drive addresses as a requirement for operations via RS-485.

With the RS 232, it is possible to parameterize only one drive at a time when using the DriveTop startup program.

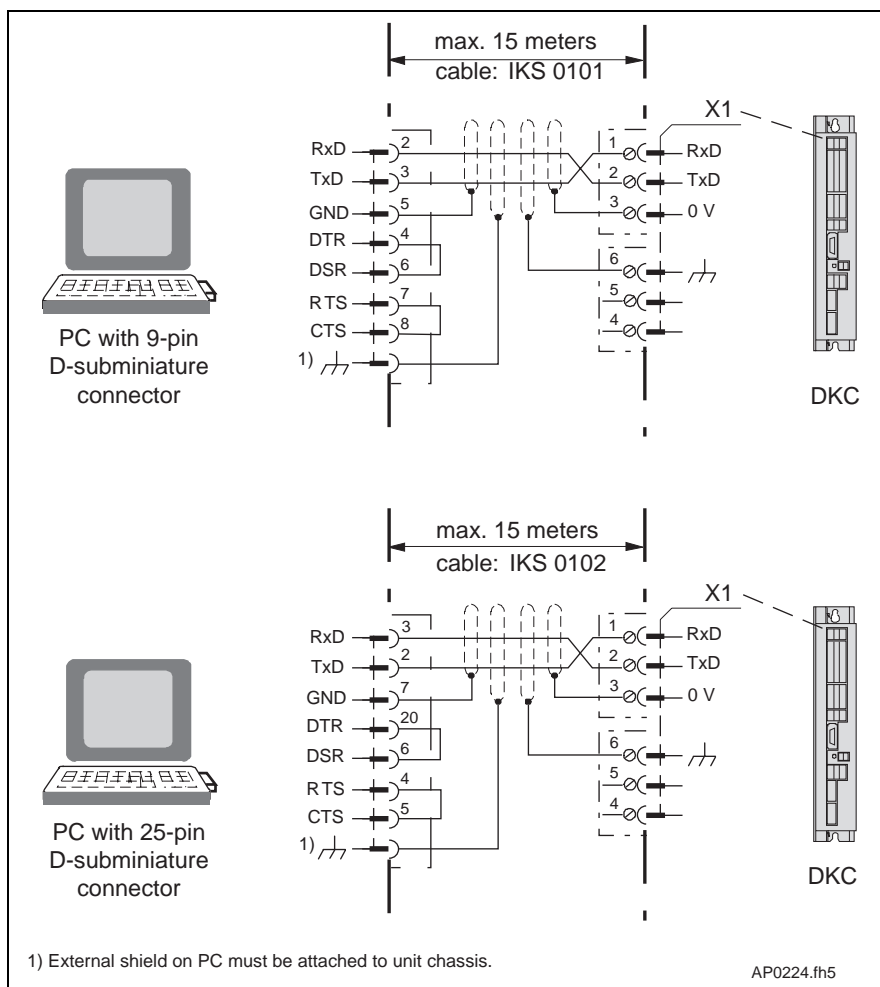

Fig. 4-19: Connecting a PC to a RS-232 interface on a DKC



**RS-485 interface** The RS-485 interface is needed for programming, parameterizing and diagnosis during startup operation and service procedures.

The RS 485 interface allows :

- the implementation of a serial bus with up to 31 stations connected by means of a twisted pair cable (half duplex mode),
- a transmission length of up to 500 meters
- data rates of 9600/19200 baud and
- the implementation of a central PC-based visualization unit.

Via the RS-485 several DKCs can be put into operation with Drive Top without reconnecting the interface cable.

To operate DriveTop with several ECODRIVES, a RS-232/485 converter is required between the PC and the drives.

The following application example displays a tested assembly with RS-485 connection using the Phoenix Contact converter PSM-EG-RS232/RS485-P/2D.

**Interface converter PSM-EG-RS232/RS485-P/2D**

The Phoenix Contact interface converter PSM-EG-RS232/RS485-P/2D implements the interface in a way suited for industrial use and for assembly in cabinets.

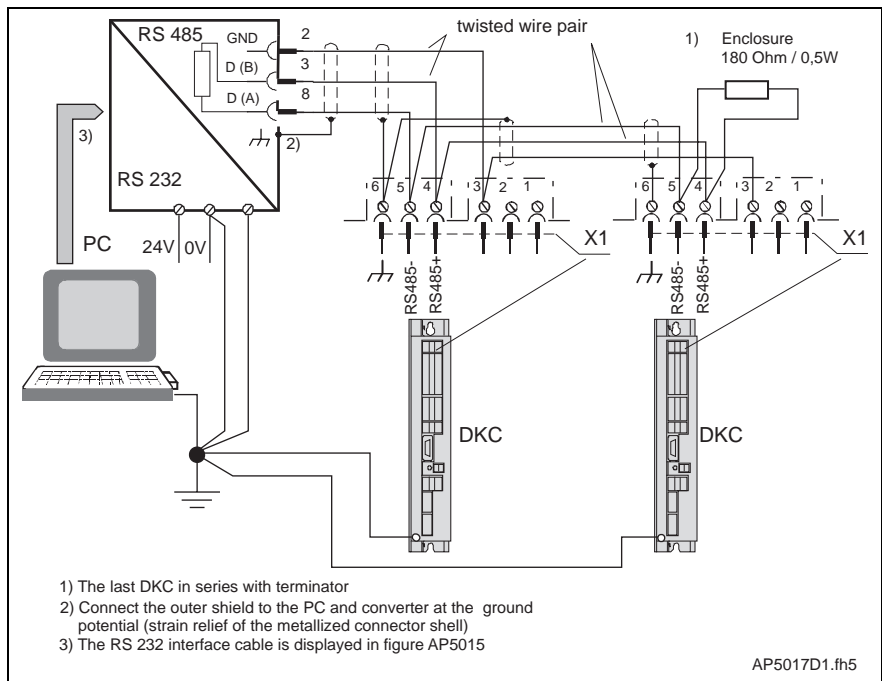

Fig. 4-20: RS-485 Connecting several DKCs

**Note:** The cable connection to the equipment must not be arranged in a star topology but must be wired individually from one DKC to the next.

The RS-485 requires a terminator on both ends. Both the terminator integrated into the interface converter (180 Ohms) and the pull-up and pull-down resistors (470 Ohms each) must be activated. The other end of the cable must also be terminated with a 180 Ohm / 0.5W resistor. The terminator is connected directly to the DKC, plug X1, pins 4 and 5.

**Switch position in the interface converter**

The converter can be modified for various peripherals by using specific switch positions.

The switch positions shown below must be used strictly for the following wiring diagrams.

- Switch RS-485 to **ON**  
⇒ 180 Ohm circuit termination and 470 Ohms pull-up/down are connected
- Switch RS232 to **DTE** (Data Terminal Equipment)  
data direction change-over for RS-485 via RTS  
⇒ pin 2: TxD, pin 3: RxD,
- Set the jumper connection to 3 and 4 -  
data direction change-over polarity  
⇒ transmit mode      Signal to RTS +3V to +15V  
⇒ receive mode        Signal to RTS -3V to -15V

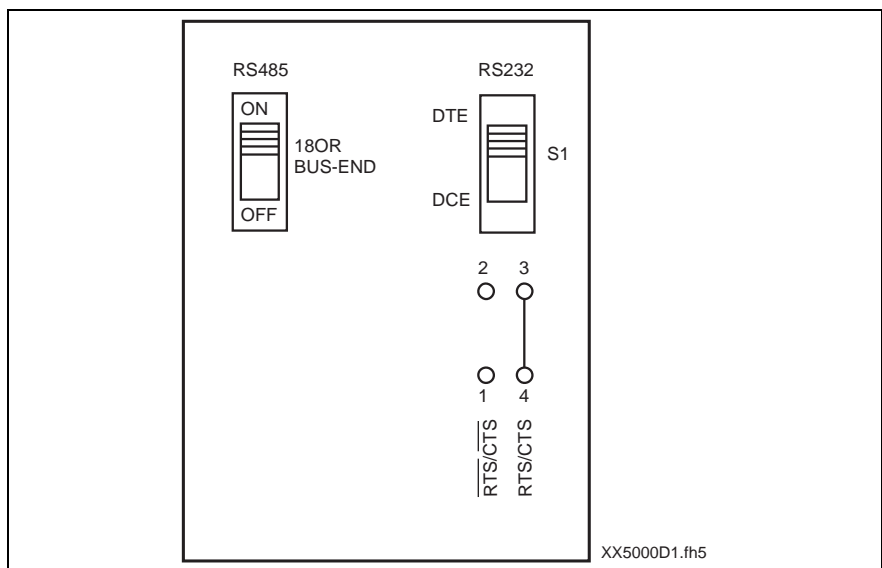

Fig. 4-21: Switch position /jumper position in the interface converter PSM-EG-RS 232 / RS 485-P / 2D

**Connecting the RS-232 of the PCs to the interface converter**

The interface converter must be connected via the D-SUB male connector because of the effects of interference.

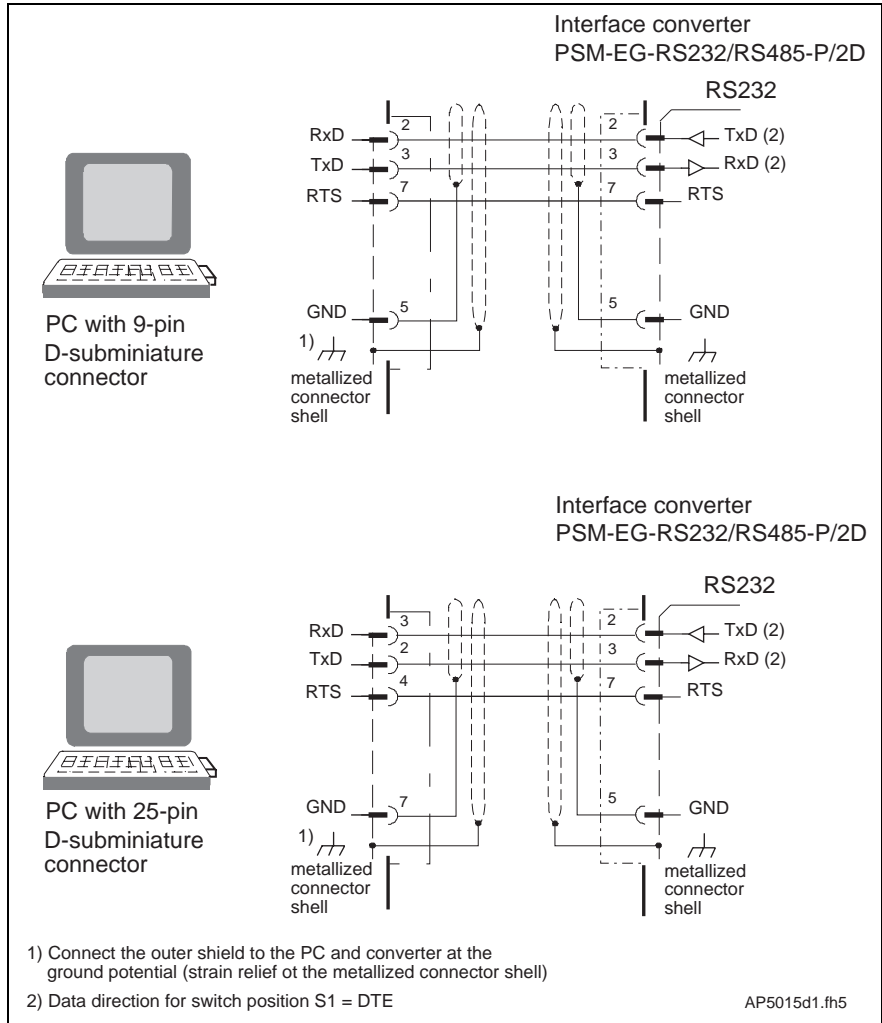

Fig. 4-22: RS-232 cable (PC interface converter)

**Connecting the RS 485 of the interface converter to the DKC**

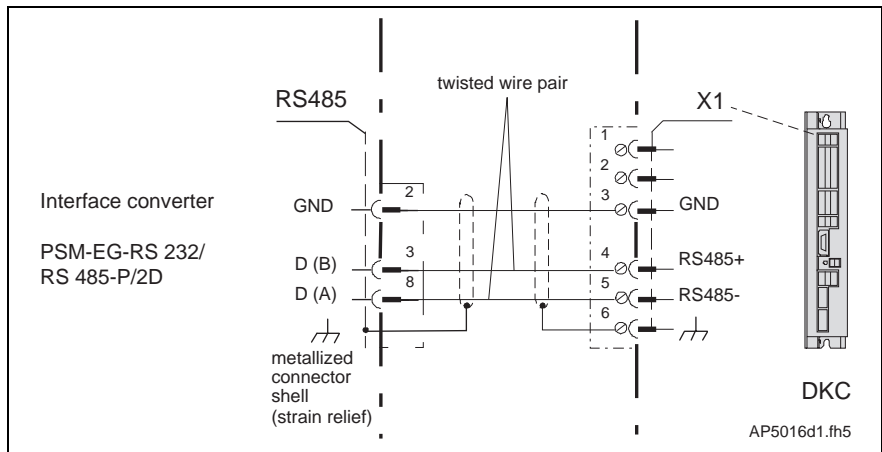

Fig. 4-23: RS-485 cable (interface converter - DKC)

## X2 positioning or stepper interface

**Note:** Does not apply to the DKC11.1-040-FW!

The cables for the control inputs and status reports required for both the POSITIONING interface and the stepper interface are connected to the X2/(13-24) supply terminals.

The X2/(1-12) supply terminal is given its function by parameterizing the operating mode during startup.

- The positioning blocks are selected at the POSITIONING interface.
- The signals for the stepper motor control are transmitted via these terminal strips at the stepper interface.

### Control inputs and status reports in the positioning and stepper interface

#### Control inputs for referencing

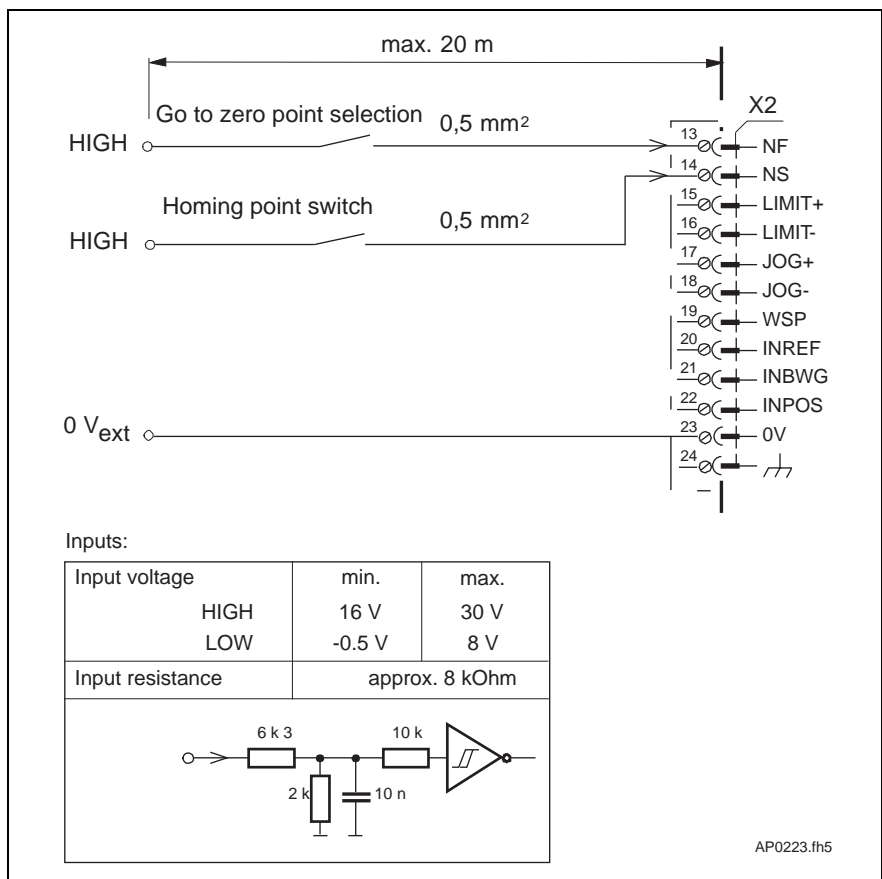

Fig. 4-24: Inputs for referencing

Control inputs for jog mode

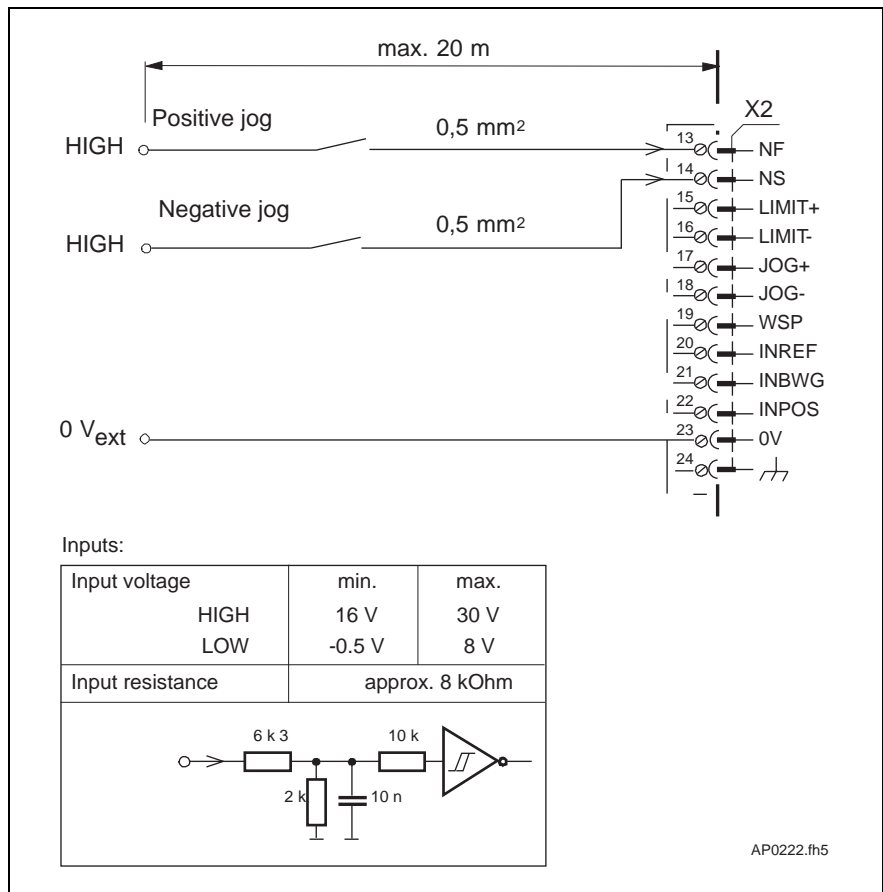

Fig. 4-25: Jog inputs

Control inputs for the travel range limit/sensor inputs

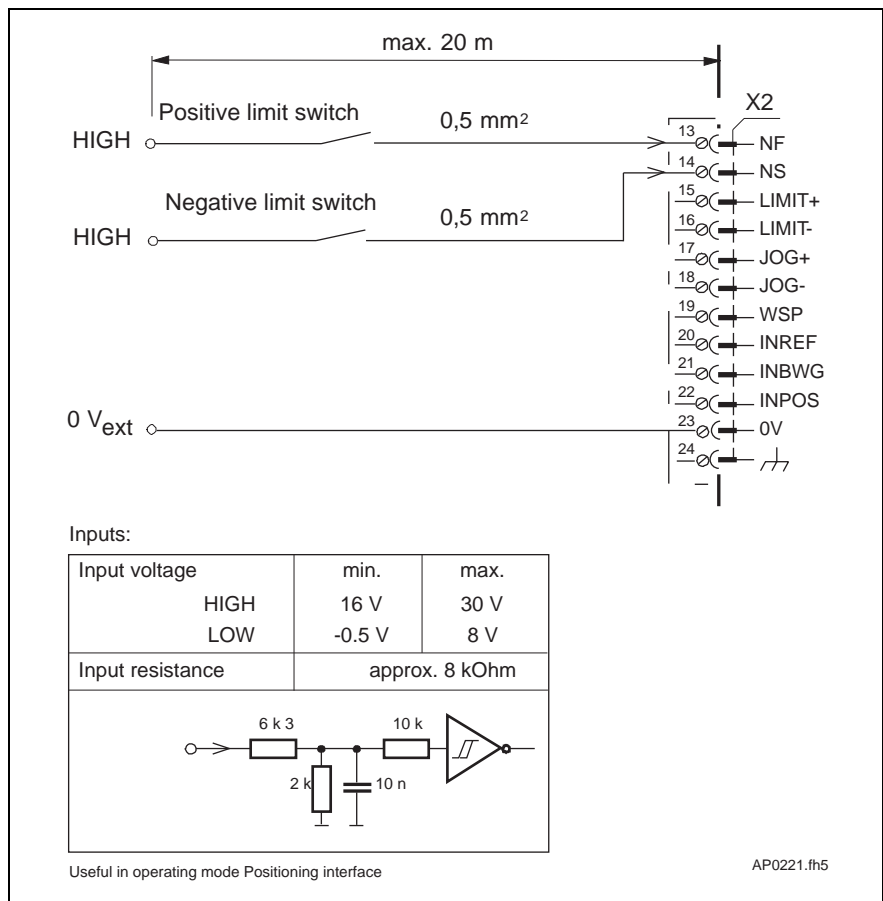

Fig. 4-26: Travel limit switch

Status reports

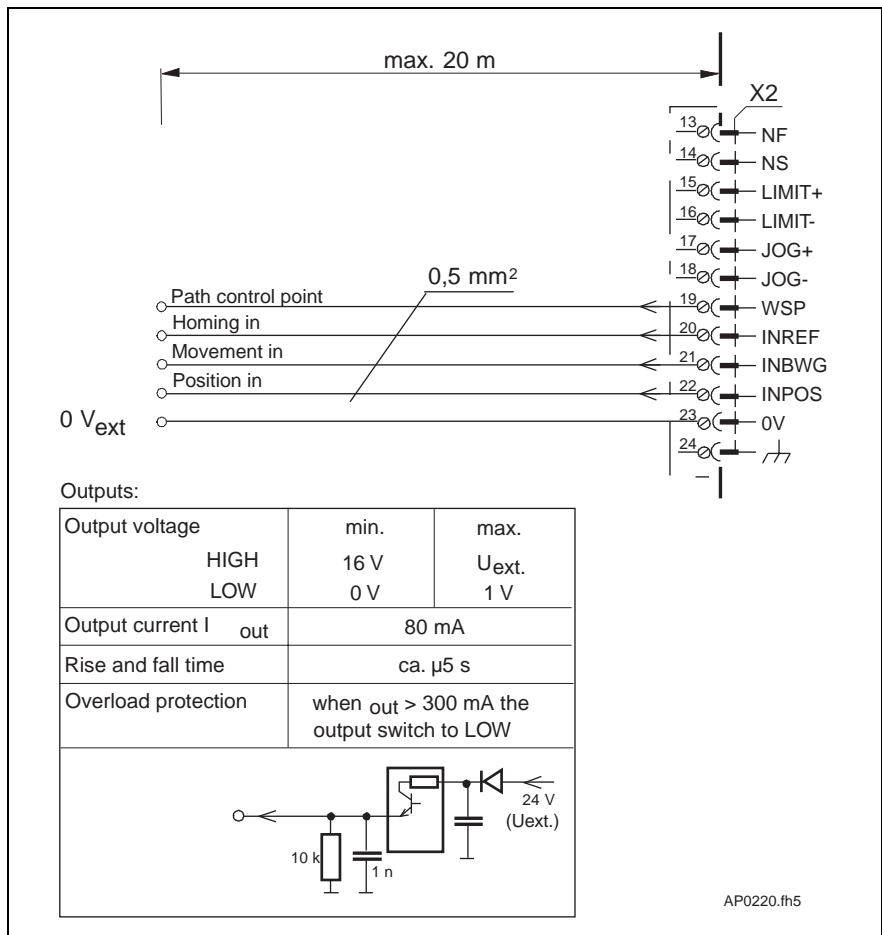

Fig. 4-27: Status reports

Positioning interface

Positioning signals and outputs for acknowledging the positioning signals

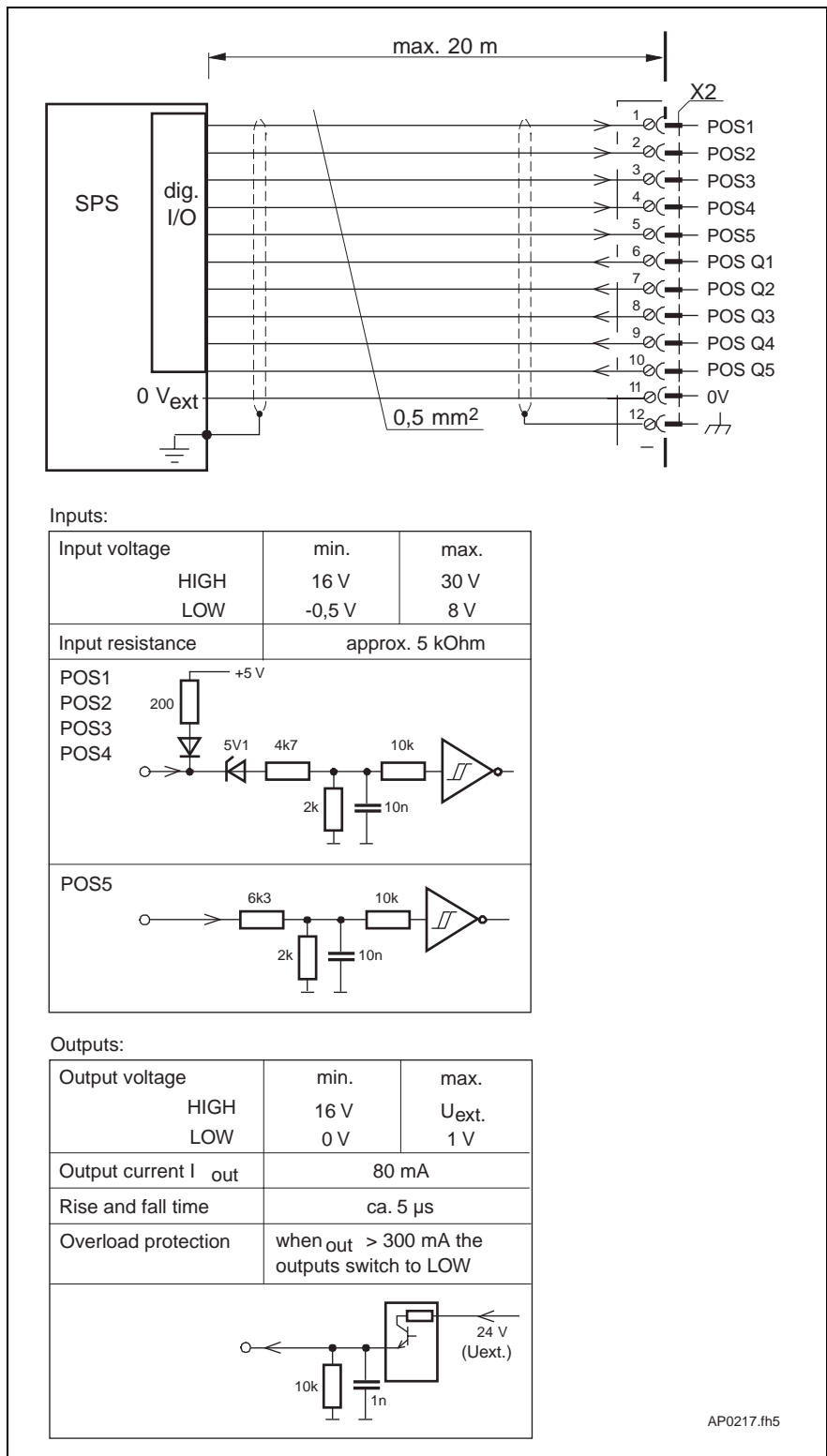

Fig. 4-28: Connecting the positioning input signals and outputs for acknowledging the positioning signals

**Note:** If the inputs POS 1 and POS 2 in Fig. 4-28 are assigned a LOW signal, 5 volts are applied there. If a PLC is connected, this can cause the control LEDs to respond. This is prevented by an interconnected blocking diode in accordance with the circuit proposal Fig. 4-29.

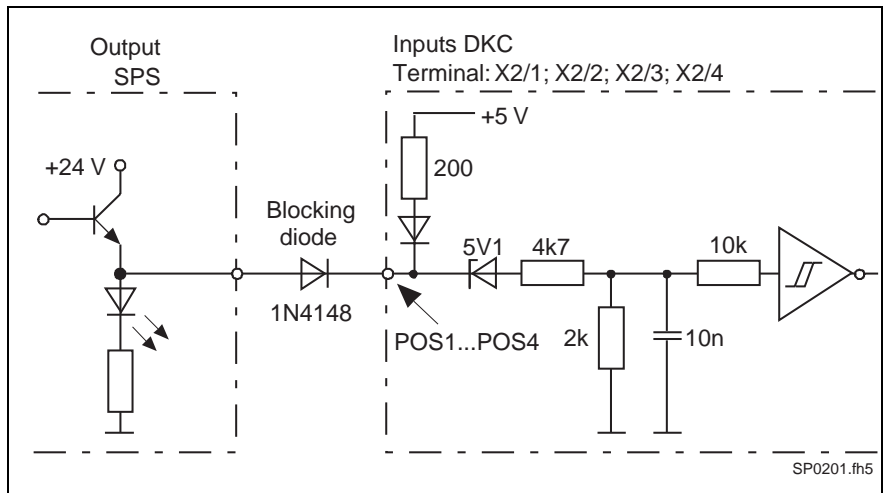

Fig. 4-29: Circuit proposal

### Stepper interface

#### Control modes via the stepper interface

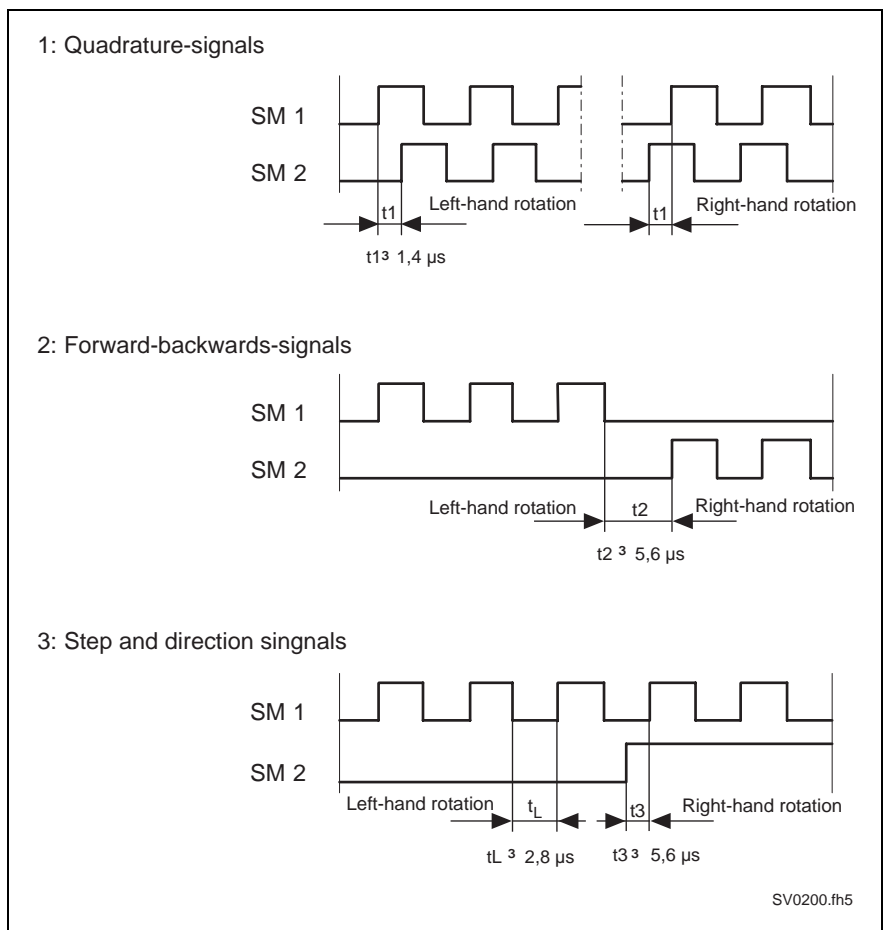

Fig. 4-30: Control modes of the stepper interface



**Control with differential signals**

- Logical 1 is recognized if a positive differential voltage is applied from SM+ to SM-.
- Logical 0 is recognized if a negative differential voltage is applied from SM+ to SM-.
- To increase noise immunity, the differential voltage range should be at least 2.5 volts. The greater the differential voltage range, the higher the operational reliability against interference.

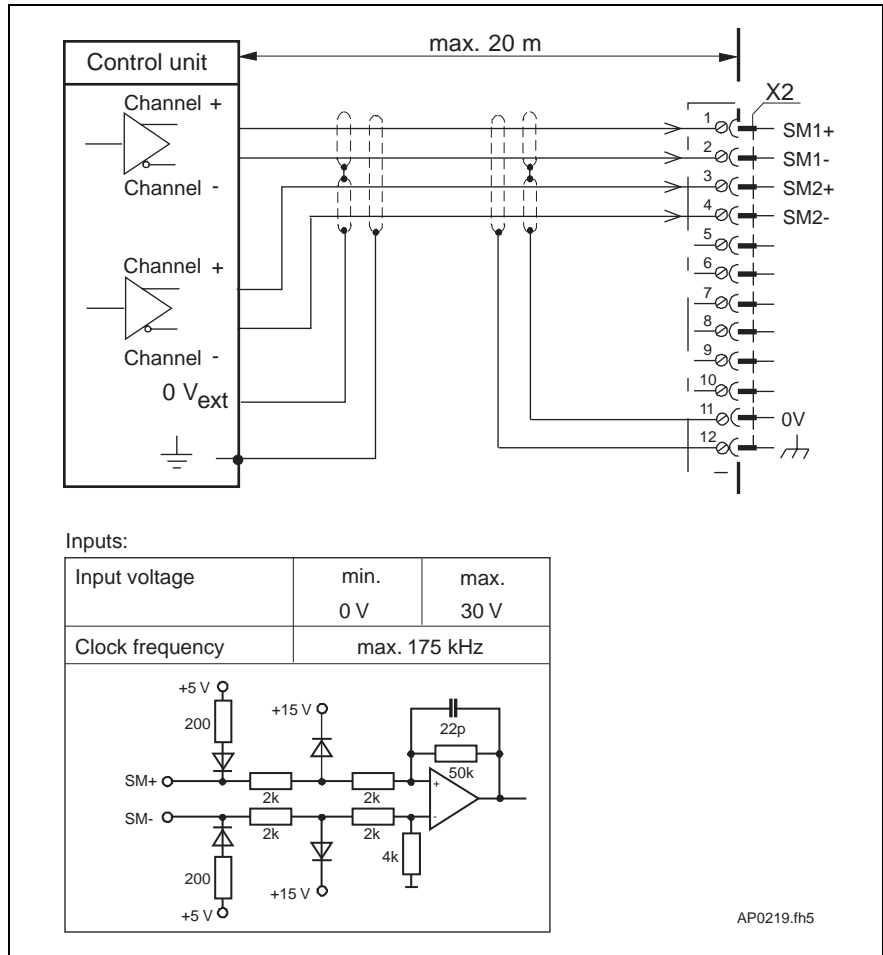

Fig. 4-31: Control with differential signals

**Single-channel control via npn – open-collector outputs (NPN)**

Dimensioning the pull-up resistors (2k4 resistors in Fig. 4-32 depends on the load capability (current, power dissipation) of the open-collector outputs of the control.

**Note:** Controlling the stepper interface with differential signals is preferable to single-channel control as the noise immunity of differential signals is generally better than with zero-referenced signals.

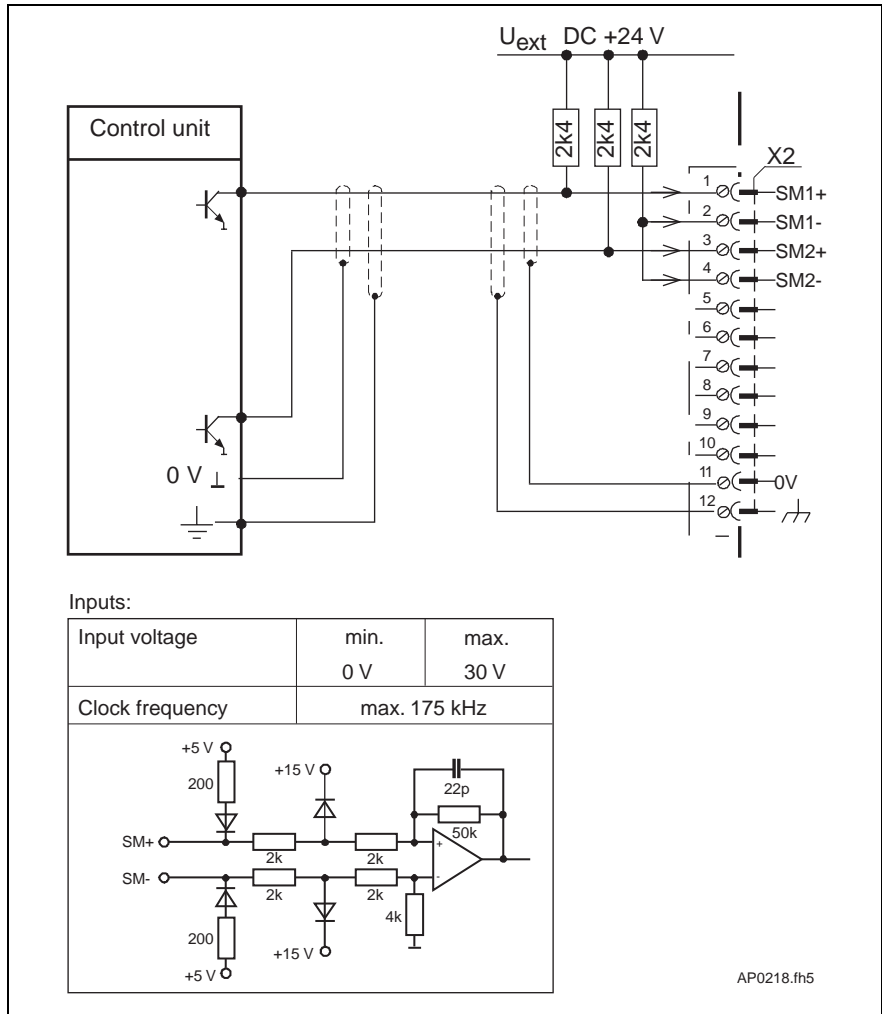

Fig. 4-32: Control with open-collector outputs

### X3 analog inputs and outputs

The inputs and outputs for operating the analog interfaces are connected via the supply terminal X3/(1-8).

- torque reduction
- setpoint input
- diagnostics outputs
- override function for positioning control

The actual position is output either as an incremental, parallel or absolute value serial via the X3/(9-16) supply terminal.

#### Analog interface

Analog setpoint input for control of speed or torque and override function

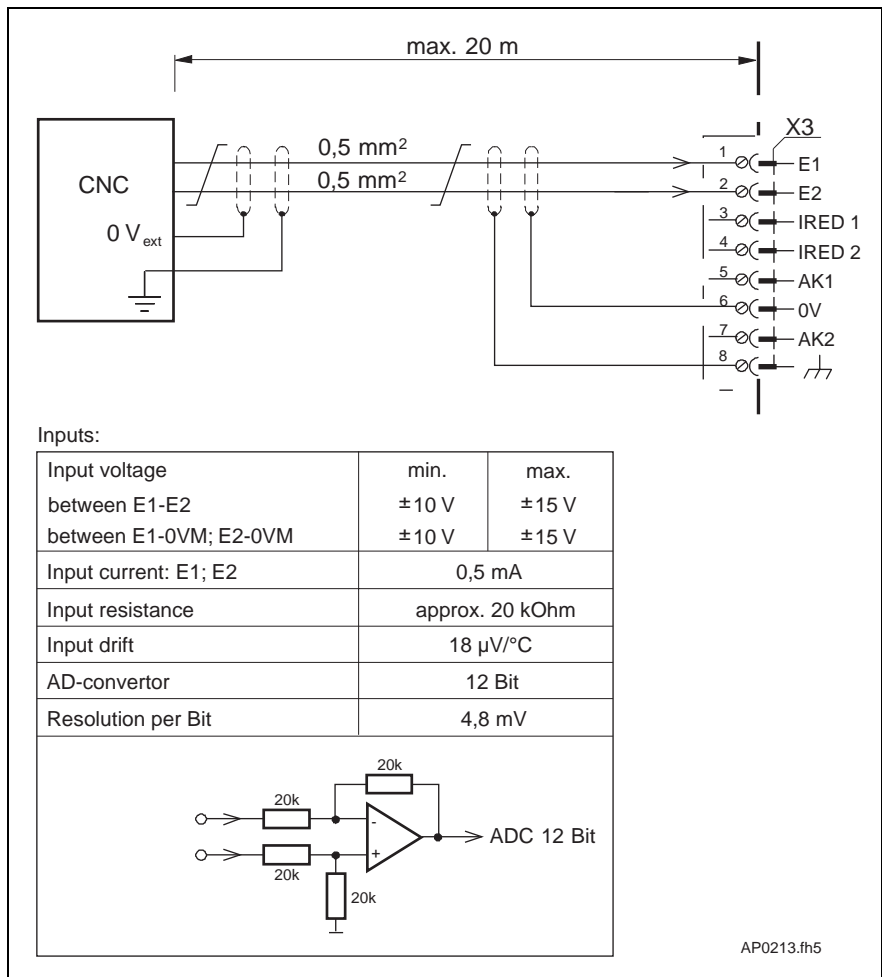

Fig. 4-33: Analog setpoint input

Torque reduction

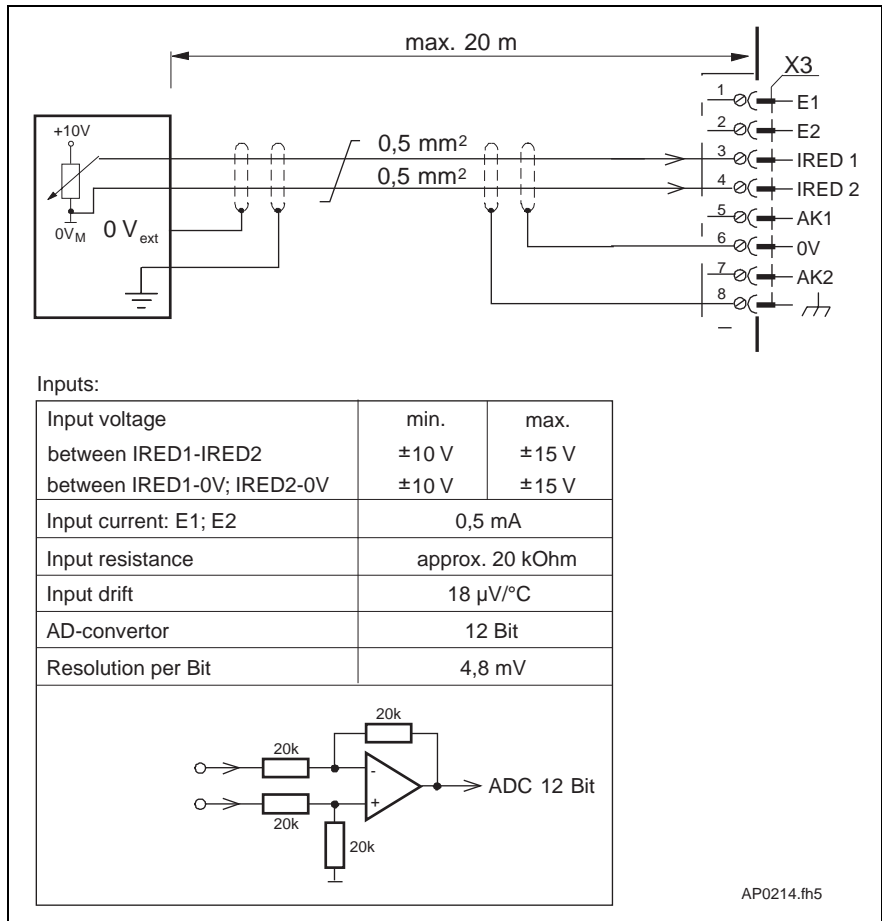

Fig. 4-34: Connecting the analog torque reduction

Diagnostics outputs

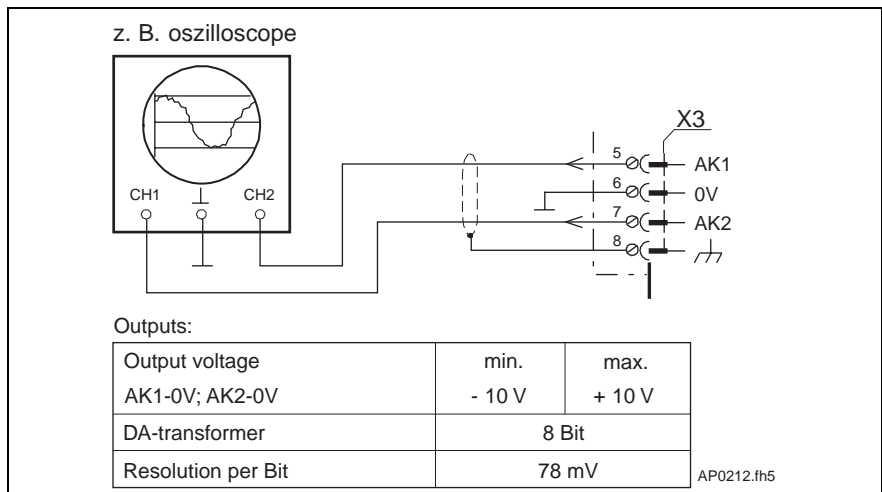

Fig. 4-35: Connection assignments of the diagnostic outputs

Actual position value

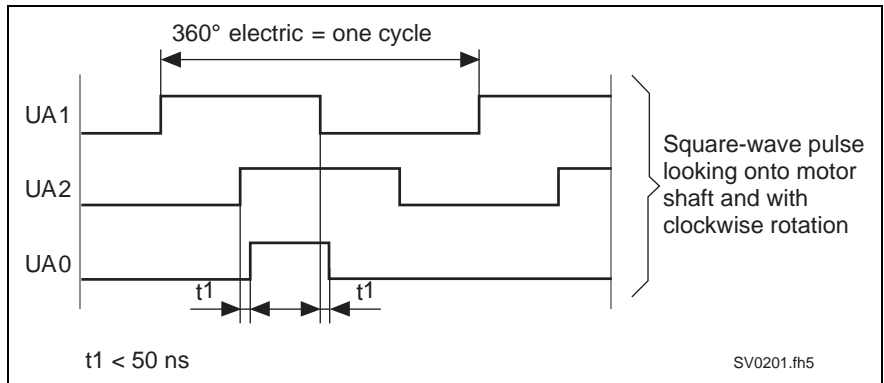

Fig. 4-36: Signals for the incremental actual position value output

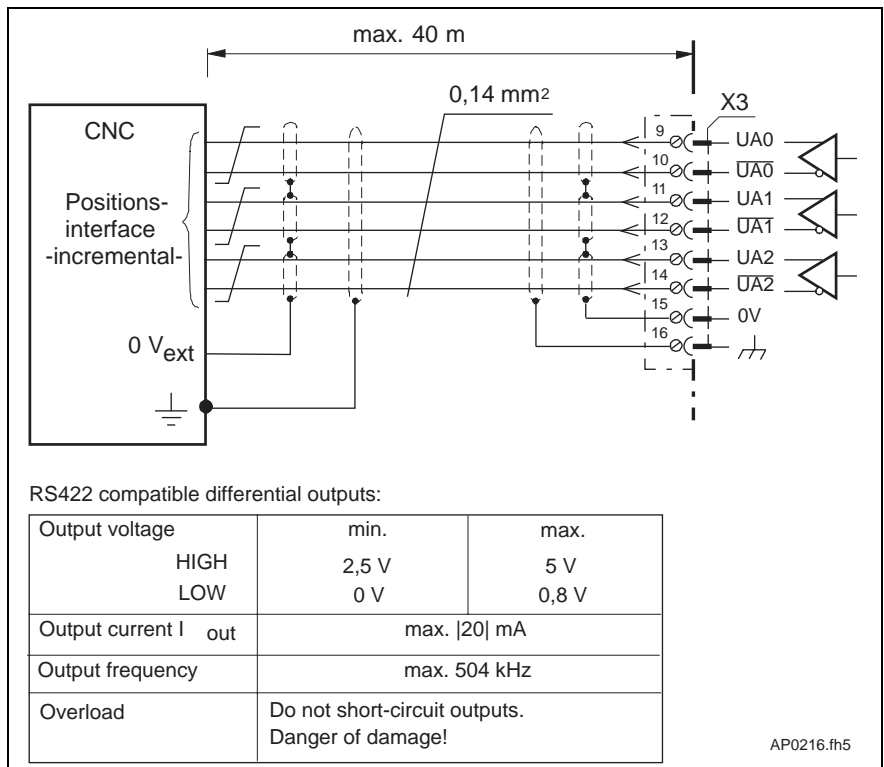

Fig. 4-37: Incremental actual position value output

Recommended input circuit for secondary electronics

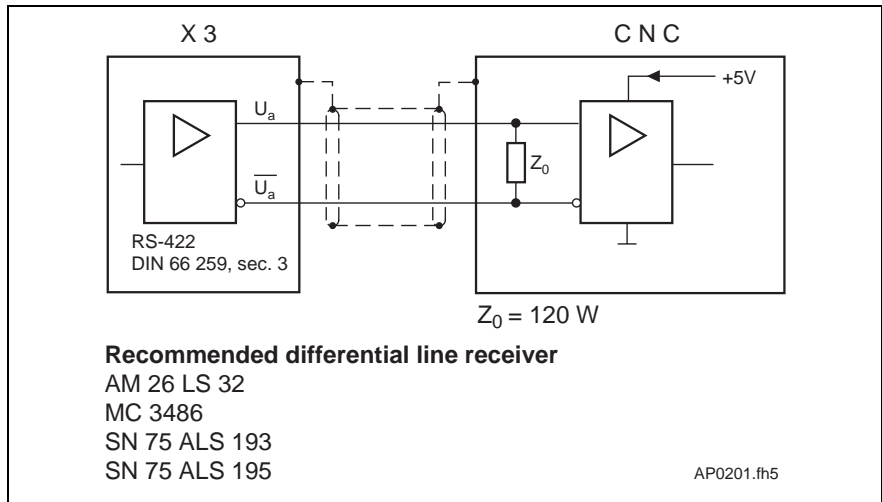

Fig. 4-38: Recommended input circuit

Actual position value, in the SSI format

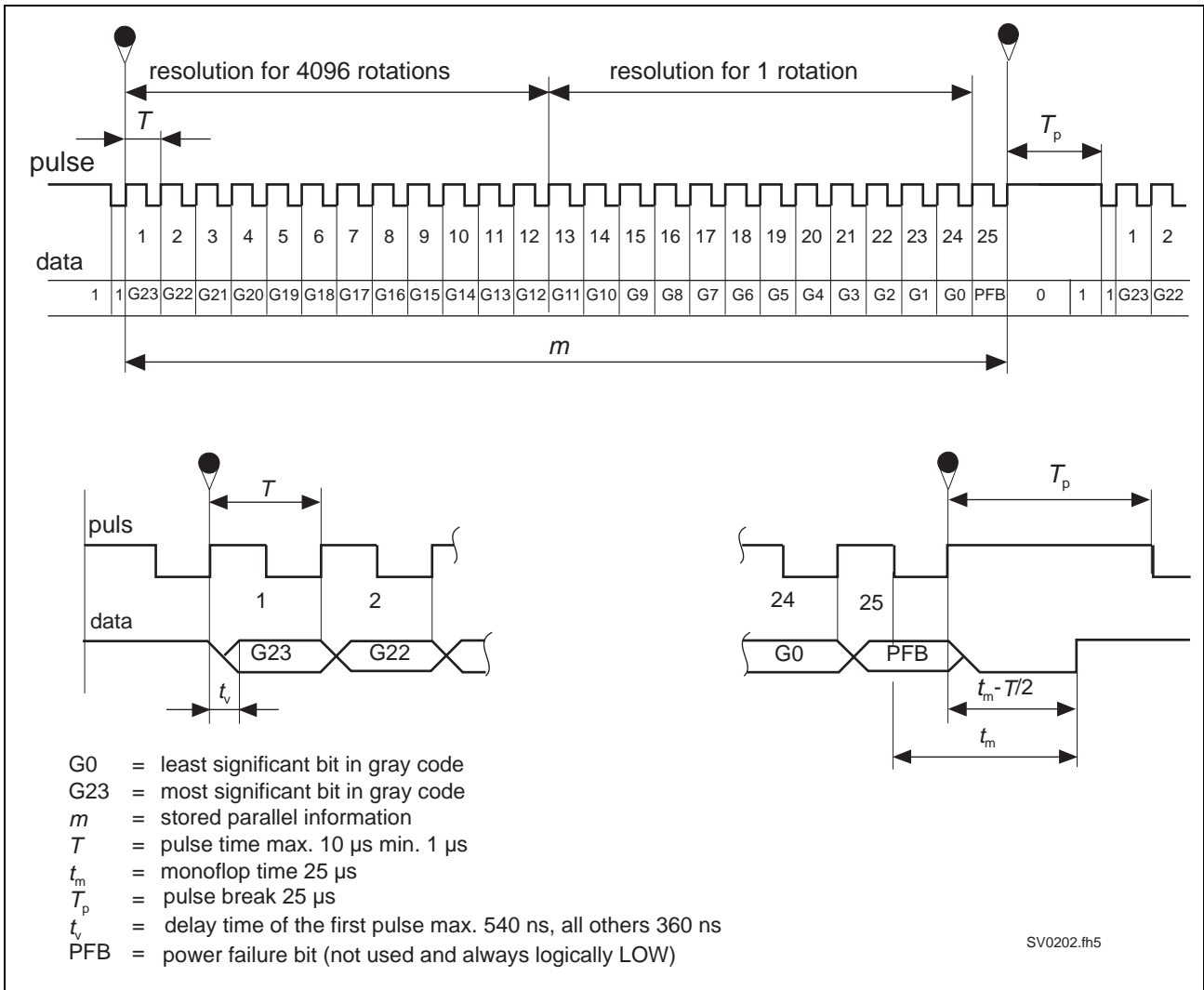

Fig. 4-39: Pulse timing diagram for absolute actual position value output (SSI format)

Actual value position SSI format

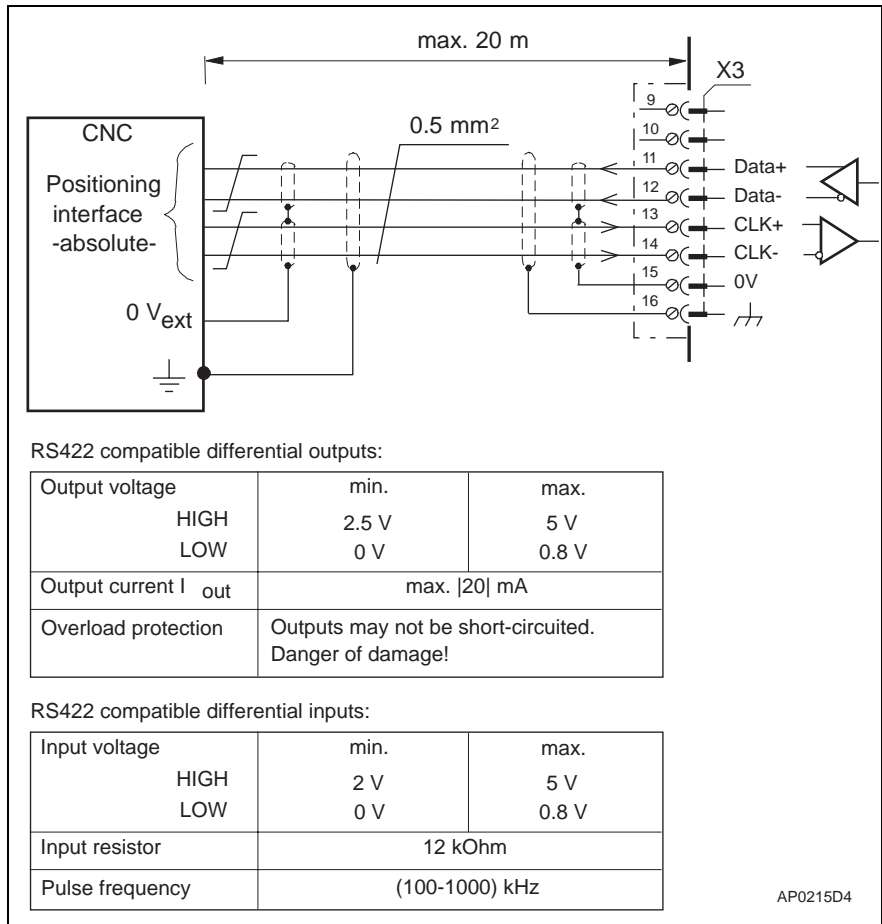

Fig. 4-40: Output of the absolute actual position value according to the SSI format

X4 terminals for the control circuit

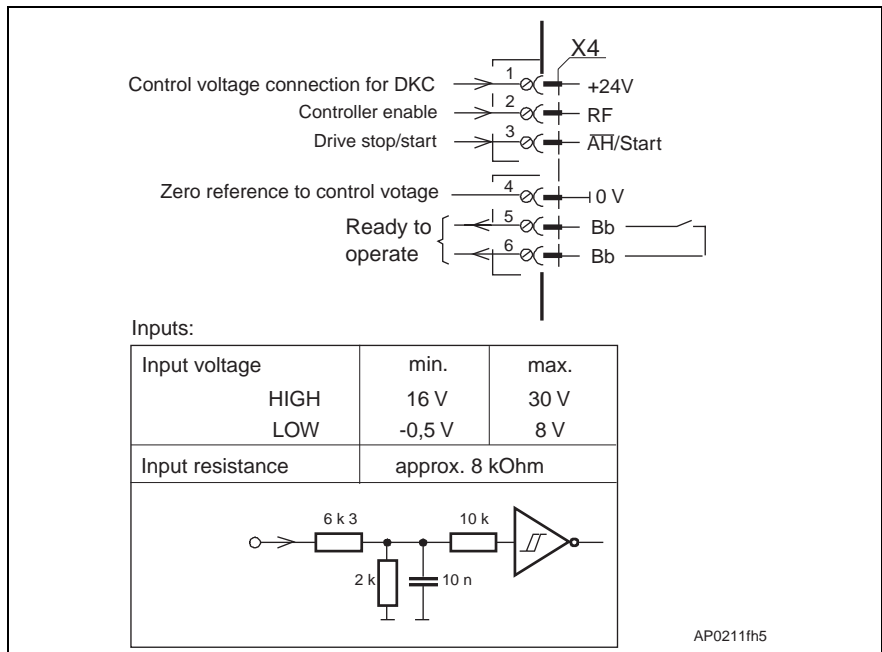

Fig. 4-41: Terminals for the control inputs, control voltage, and stand-by contact

## X5, X6, X7 motor connections

For the terminal connection assignments to the motor connections, refer to the overall connection diagram in Fig. 4-15.

For further information, please see the documentation "ECODRIVE servomotors MKD" - Project Planning Manual -.

## X9 DC bus connection

---

**Note:** Does not apply to DKC01.1-030-3-FW!

---

DC bus connection for connecting:  
an auxiliary bleeder module BZM01.1

- or -

an auxiliary capacitance module CZM01.1

- or -

a DKC drive controller

The maximum line length is 1.0 m (twisted) with at least a 2.5 m<sup>2</sup> cross section.

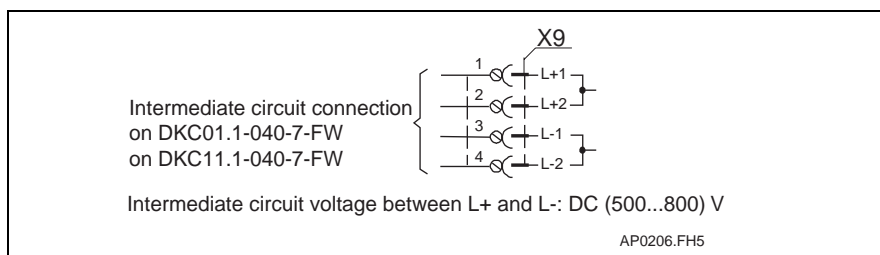

Fig. 4-42: DC bus connection



## 5 BZM auxiliary bleeder module

### 5.1 Dimensioning the components relevant for regeneration

For each servo-technical application, it is necessary to check whether the

- continuous regenerative power
- peak regenerative power
- regenerative energy

needed for the application can be sufficiently absorbed by the bleeder (brake resistance).

If the available regenerative power and energy from the mechanics exceeds the absorbing capabilities of the bleeder built into the unit, this capability can be increased on the DKC\*\*.\*-040-7-FW by using the following hardware configurations.

- A drive and auxiliary bleeder module connected via the DC bus circuit. (1 DKC+BZM)
- Several drive controllers connected via the DC bus circuit. (up to 6 DKCs)
- Several drive controllers and auxiliary bleeder modules connected via the DC bus circuit. (up to 6 DKC+BZM)

## 1 DKC + BZM

**1. Continuous regenerative power**

$$P_{RD} \leq P_{BD, DKC} + P_{BD, BZM}$$

$$P_{RD} = \frac{\sum W_{ROT} + \sum W_{POT}}{t_Z \cdot 1000}$$

$$W_{ROT} = \frac{(J_{LAST} + J_M)}{2} \cdot (n_{NUTZ} \cdot \frac{2 \cdot \pi}{60})^2 \cdot z_{DEC}$$

$$W_{POT} = m_{LAST} \cdot g \cdot h \cdot z_{AB}$$

**2. Peak regenerative power**

$$P_{RS} \leq P_{BM, DKC} + P_{BM, BZM}$$

$P_{RS}$  -> siehe Auswahldaten zu den Servoantrieben

**3. Regenerative energy (a single braking in E-stop)**

$$W_{POT, MAX} + W_{ROT, MAX} \leq W_{MAX, DKC} + W_{MAX, BZM}$$

$W_{MAX, DKC}$  -> siehe Abb. Technische Daten DKC

$W_{MAX, BZM}$  -> siehe Abb. Technische Daten BZM

$P_{RD}$ :	continuous regenerative power from the mechanical system during operation in kW
$P_{BD, DKC}$ :	continuous regenerative power in kW that the drive controller can process in continuous operation
$P_{BD, BZM}$ :	continuous regenerative power that the auxiliary module can process in continuous operation, in kW
$P_{RS}$ :	peak regenerative power in kW
$W_{ROT}$ :	rotary energy in Ws
$W_{POT}$ :	potential energy in Ws
$W_{ROT, MAX}$ :	max. occurring rotary energy in an emergency stop in Ws
$W_{POT, MAX}$ :	max. occurring potential energy in an emergency stop (E-stop) in Ws
$t_Z$ :	cycle time in s
$J_{LAST}$ :	load torque in kgm <sup>2</sup>
$J_M$ :	motor inertia, in kgm <sup>2</sup>
$m_{LAST}$ :	load weight in kg
$W_{MAX, BZM}$ :	storable energy in the BZM in kW
$W_{MAX, DKC}$ :	storable energy in the DKC in kW
$g$ :	gravitational acceleration 9.81 ms <sup>-2</sup>
$h$ :	lowering dimension in m
$n_{NUTZ}$ :	motor speed used in min-1
$z_{AB}$ :	number of drops per cycle
$z_{DEC}$ :	number of braking actions per cycle

Fig. 5-1: Check the conditions for regenerative power and regenerative energy in a DKC connected to a BZM via the DC bus

up to 6 DKCs

**1. Continuous regenerative power**

$$\sum P_{RD} \leq 0,8 \cdot \sum P_{BD,DKC}$$

$$P_{RD} = \frac{\sum W_{ROT} + \sum W_{POT}}{t_z \cdot 1000}$$

$$W_{ROT} = \frac{(J_{LAST} + J_M)}{2} \cdot \left( n_{NUTZ} \cdot \frac{2 \cdot \pi}{60} \right)^2 \cdot z_{DEC}$$

$$W_{POT} = m_{LAST} \cdot g \cdot h \cdot z_{AB}$$

**2. Peak regenerative power**

$$\sum P_{RS} \leq 0,8 \cdot P_{BM,DKC}$$

$P_{RS}$  -> siehe Auswahldaten zu den Servoantrieben

**3. Regenerative energy (a single braking in E-stop)**

$$\sum W_{POT, MAX} + \sum W_{ROT, MAX} \leq 0,8 \cdot \sum W_{MAX, DKC}$$

$W_{MAX, DKC}$  -> siehe Abb. Technische Daten DKC

$P_{RD}$ :	continuous regenerative power of the mechanical system that is generated in continuous operation, in kW
$P_{BD, DKC}$ :	continuous regenerated power that the drive controller can process in continuous operation, in kW
$P_{RS}$ :	peak regenerated power in kW
$W_{ROT}$ :	rotary energy in Ws
$W_{POT}$ :	potential energy in Ws
$W_{ROT, MAX}$ :	max. occurring rotary energy in an E-stop in Ws
$W_{POT, MAX}$ :	max. occurring potential energy in an E-stop in Ws
$t_z$ :	cycle time in s
$J_{LAST}$ :	load torque in kgm <sup>2</sup>
$J_M$ :	motor inertia, in kgm <sup>2</sup>
$m_{LAST}$ :	load weight in kg
$W_{MAX, BZM}$ :	storable energy in BZM 01.1 in kW
$W_{MAX, DKC}$ :	storable energy in the DKC in kW
$g$ :	9.81 ms <sup>2</sup>
$h$ :	lowering dimension in m or number of braking actions
$n_{NUTZ}$ :	motor speed used in min-1
$z_{AB}$ :	number of drops per cycle
$z_{DEC}$ :	number of braking actions per cycle

Fig. 5-2: Checking the conditions for regenerative power and regenerative energy with several DKCs connected via the DC bus

up to 6 DKCs + BZM

**1. Continuous regenerative power**

$$\sum P_{RD} \leq 0,8 \cdot \sum P_{BD,DKC} + \sum P_{BD,BZM}$$

$$P_{RD} = \frac{\sum W_{ROT} + \sum W_{POT}}{t_z \cdot 1000}$$

$$W_{ROT} = \frac{(J_{LAST} + J_M)}{2} \cdot (\eta_{NUTZ} \cdot \frac{2 \cdot \pi}{60})^2 \cdot z_{DEC}$$

$$W_{POT} = m_{LAST} \cdot g \cdot h \cdot z_{AB}$$

**2. Peak regenerative power**

$$\sum P_{RS} \leq 0,8 \cdot P_{BM,DKC} + P_{BM,BZM}$$

$P_{RS}$  -> siehe Auswahldaten zu den Servoantrieben

**3. Regenerative energy (a single braking in the E-stop position)**

$$\sum W_{POT,MAX} + \sum W_{ROT,MAX} \leq 0,8 \cdot \sum W_{MAX,DKC} + \sum W_{MAX,BZM}$$

$W_{MAX,DKC}$  -> siehe Abb. Technische Daten DKC

$W_{MAX,BZM}$  -> siehe Abb. Technische Daten BZM

$P_{RD}$ :	continuous regenerative power of the mechanical system that occurs in continuous operation in kW
$P_{BD,DKC}$ :	continuous regenerative power that the drive controller can process in continuous operation in kW
$P_{RS}$ :	peak regenerative power in kW
$W_{ROT}$ :	rotary energy in Ws
$W_{POT}$ :	potential energy in Ws
$W_{ROT,MAX}$ :	max. occurring rotary energy in the E-stop position in Ws
$W_{POT,MAX}$ :	max. occurring potential energy in the E-stop in Ws
$t_z$ :	cycle time in s
$J_{LAST}$ :	load torque in kgm <sup>2</sup>
$J_M$ :	motor inertia, in kgm <sup>2</sup>
$m_{LAST}$ :	load weight in kg
$W_{MAX,BZM}$ :	storable energy in BZM 01.1 in kW
$W_{MAX,DKC}$ :	storable energy in the DKC in kW
$g$ :	9.81 ms <sup>2</sup>
$h$ :	lowering dimension in m or number of braking actions
$\eta_{NUTZ}$ :	motor speed used in min <sup>-1</sup>
$z_{AB}$ :	number of drops per cycle
$z_{DEC}$ :	number of braking actions per cycle

Fig. 5-3: Check the conditions for regenerative power and regenerative energy in a DKC connected to a BZM via the DC bus

## 5.2 Dimensional data and installation dimensions

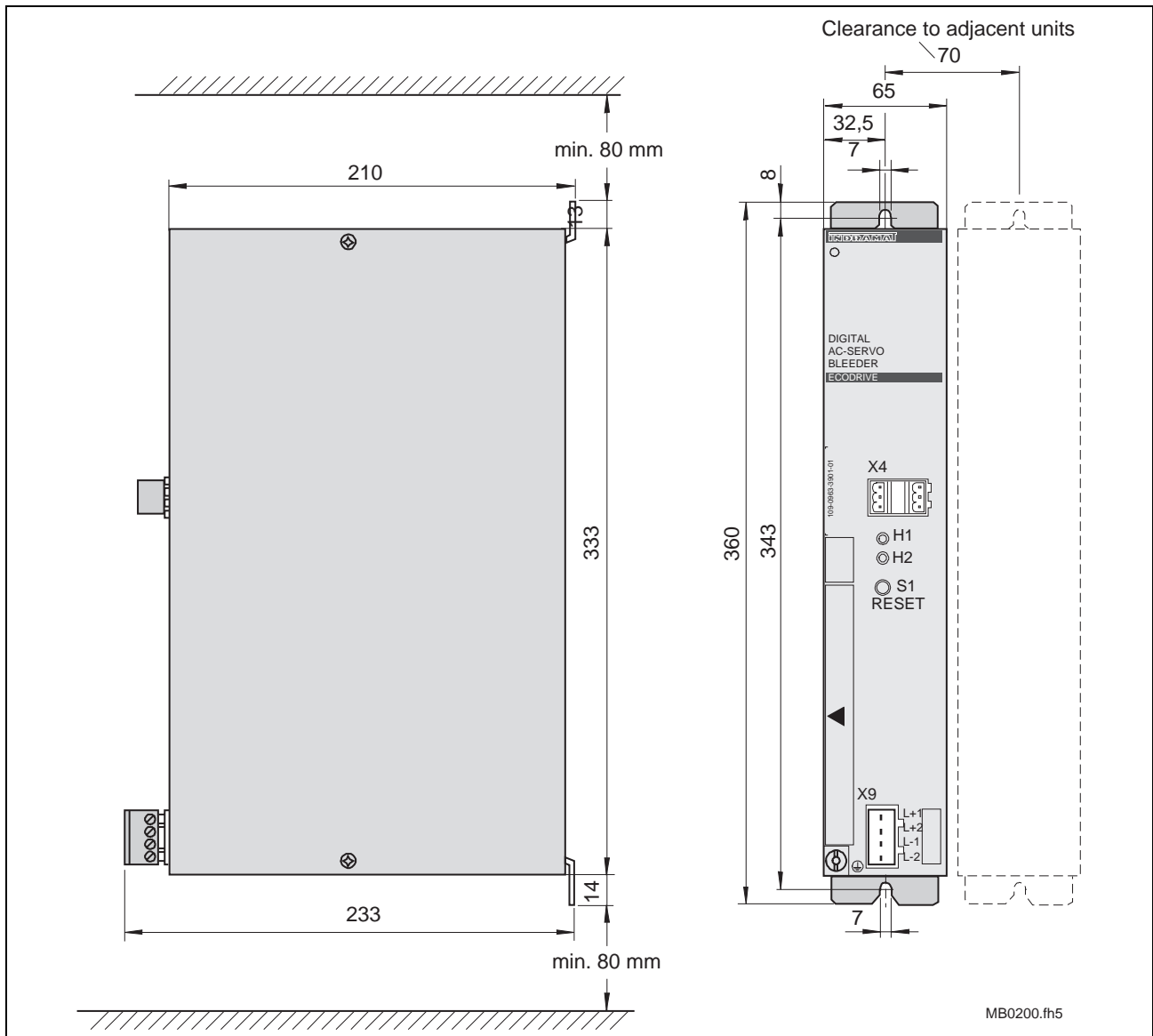

Fig. 5-4: Dimensions of the auxiliary bleeding module BZM01.1

### 5.3 Technical data

Designation	Symbol	Unit	Value
Continuous bleeder output (continuous regenerative power when drives are braked)	$P_{BD,BZM}$	kW	1
Peak bleeder power (peak regenerative power)	$P_{BM,BZM}$	kW	40 (perm. load cycle on for 1s, off for 40s)
Maximum feedback energy	$W_{MAX,BZM}$	kWs	40
Control voltage between X4/1 and X4/4	$U_{N,BZM}$	V	DC 24 V $\pm$ 20%
Current consumption of the 24 V connection	$I_{N,BZM}$	mA	90

TB0205.fh5

Fig. 5-5: Technical data for the BZM

### 5.4 Front view

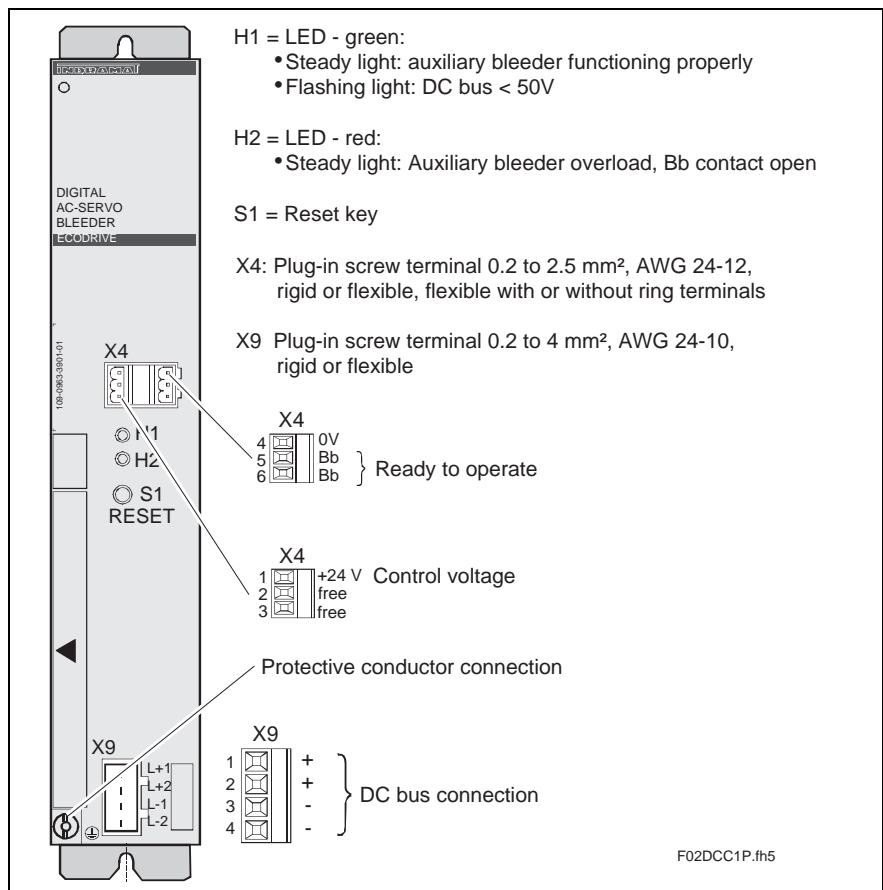

Fig. 5-6: Front view of the auxiliary bleeder module BZM01.1 with supply terminals

### 5.5 Electrical connections

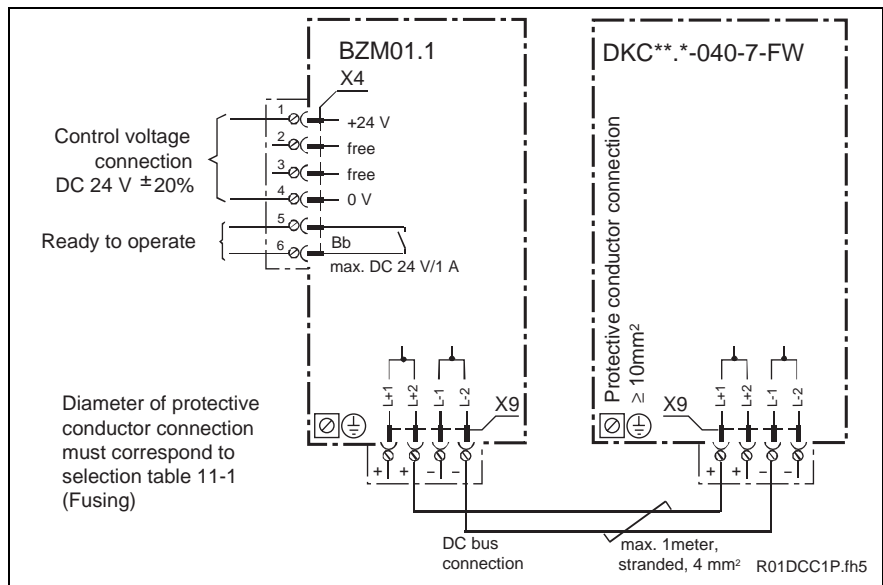

Fig. 5-7: Connection assignment for the auxiliary bleeding module BZM01.1

### 5.6 Type code and rating plate

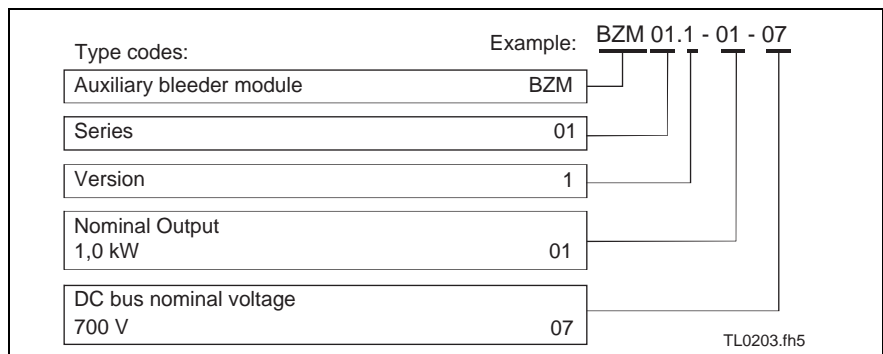

Fig. 5-8: Type code

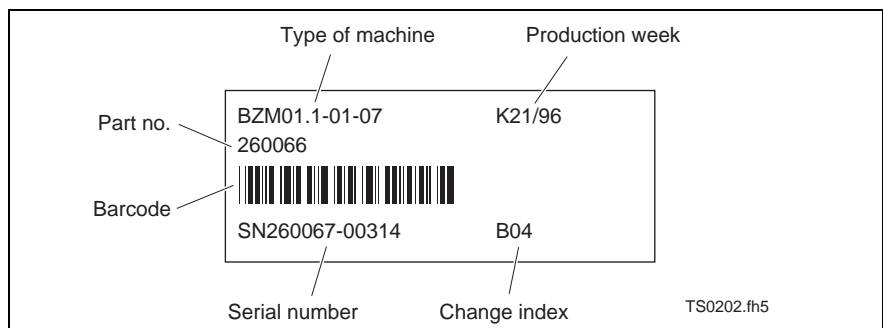

Fig. 5-9: Rating plate

## Notes



# 6 CZM Auxiliary Capacitance Module

## 6.1 Dimensioning

**Note:** Only applies to DKC01.1-040-7-FW and DKC11.1-040-7-FW!

When braking the drive, the rotary energy available in the mechanics is released as regenerative energy in the DC bus of the DKC. It can be

- released in the form of heat via the bleeder module or auxiliary bleeder integrated into the DKC

- or -

- stored as energy in the DKC with a connected auxiliary capacitance module and reused for subsequent acceleration procedures. This reduces the power dissipated in the cabinet; energy consumption is lowered.

For successful implementation while avoiding an unnecessary power loss in the cabinet, note the following:

$$W_{ROT} \leq W_{ZW, DKC+CZM}$$

Fig. 6-1: Condition for avoiding power dissipation from the regenerative energy

### Calculating the rotary energy of an application

$$W_{ROT} = \frac{(J_{LAST} + J_M)}{2} \cdot \left( n_{NUTZ} \cdot \frac{2 \cdot \pi}{60} \right)^2$$

$W_{ROT}$ : rotary energy of the application in Ws  
 $n_{NUTZ}$ : maximum effective speed in min-1  
 $J_{LAST}$ : load torque of the application in kgm<sup>2</sup>  
 $J_M$ : motor inertia

Fig. 6-2: Calculating the rotary energy

### Storable energy in the DKC with a connected CZM01.1

$$W_{ZW, DKC+CZM} = \frac{C_{DKC} + C_{CZM}}{2} \cdot (U_B^2 - U_{ZW}^2) \cdot 10^{-3}$$

$W_{ZW, DKC+CZM}$ : storable energy in the DKC with CZM in Ws  
 $C_{CZM}$ : capacity of the CZM in mF (value = 1.0 mF)  
 $C_{DKC}$ : DC bus capacity of the DKC in mF (value = 0.15 mF)  
 $U_B$ : UB : Response threshold of the bleeder in DKC in V (value = 820)  
 $U_{ZW}$ : nominal voltage (DC bus) in V ( $U_{ZW} = (2 \cdot 0.98 \text{ UN})$ )  
 $U_N$ : line voltage (effective value) in V

Fig. 6-3: Calculating the storable energy with a CZM01.1

**Application example** DKC01.-40-7 with AC motor MKD 071 B with the following data:

Designation	Value
Rotor inertia of the MKD 071 B	$J_M = 0.00087 \text{ kgm}^2$
Maximum effective motor speed	$n_{\text{Nutz}} = 3200 \text{ min}^{-1}$
Load inertia of the application	$J_{\text{LAST}} = 0.00261 \text{ kgm}^2$
Cycle time	$t_z = 0.8 \text{ s}$
Line voltage	$U_N = 400 \text{ V}$

Fig. 6-4: Technical data for application example DKC01.1 with MKD

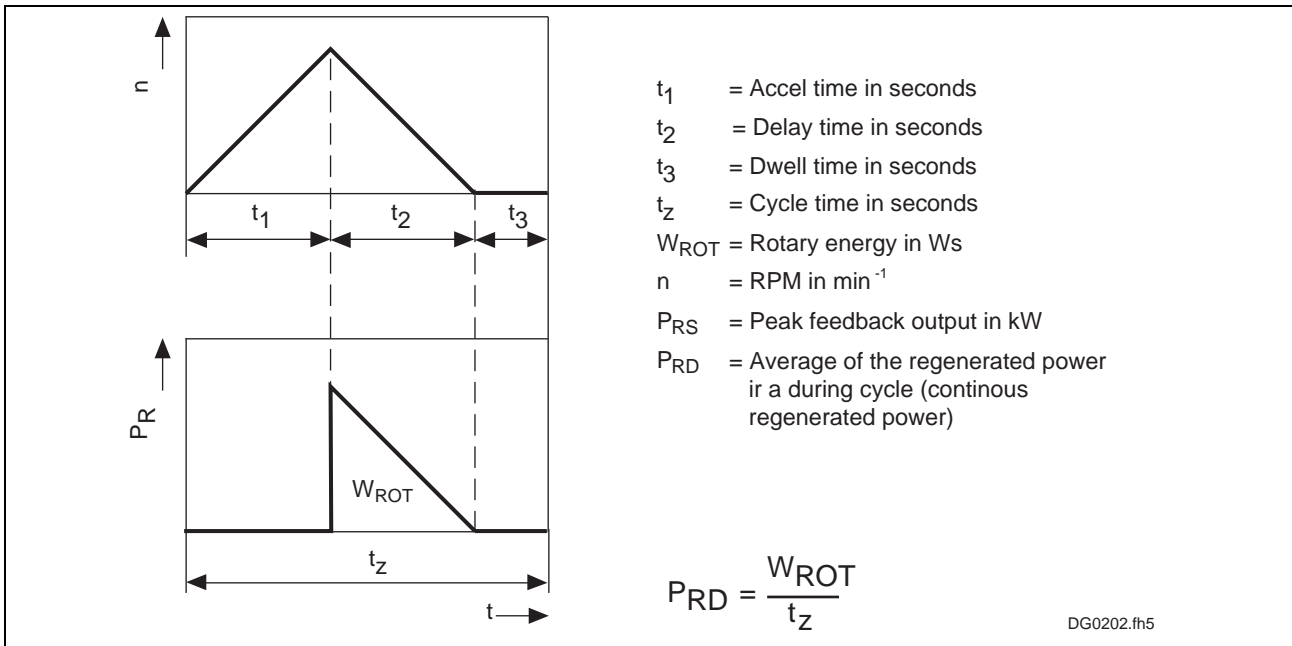

Fig. 6-5: Calculating the regenerative power in the processing cycle

This produces the following results:

$$W_{\text{ROT}} = 195 \text{ Ws}$$

$$W_{\text{ZW, DKC+CZM}} = 209 \text{ Ws}$$

This indicates that the condition  $W_{\text{ROT}} \leq W_{\text{ZW, DKC+CZM}}$  has been fulfilled. If the same amount of energy were released via a bleeder, this would result in a continuous regenerative power of 243 Watts as dissipated power in the control cabinet due to the cycle time.

## 6.2 Dimensional data and installation dimensions

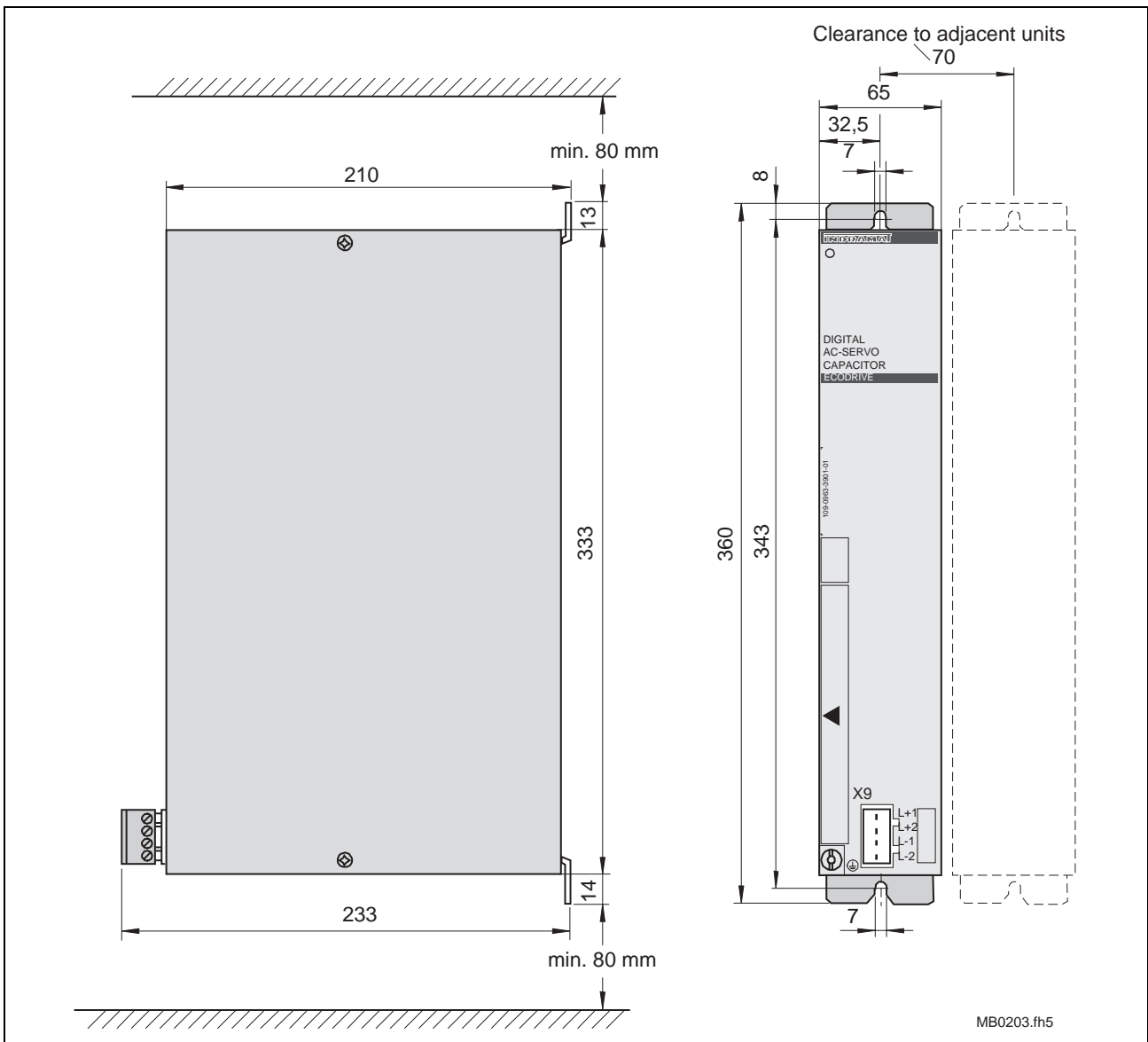

Fig. 6-6: Dimensions for the auxiliary capacitance modules CZM01.1

### 6.3 Front view

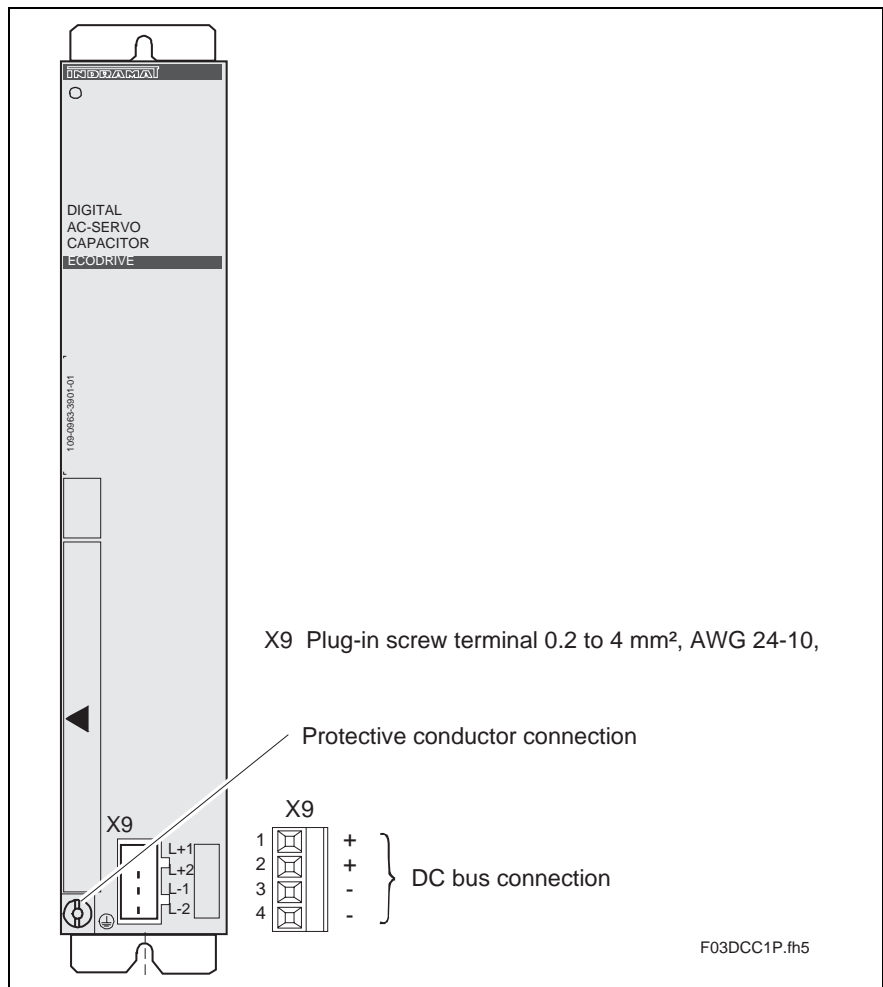

Fig. 6-7: Front view of the auxiliary capacitance module CZM01.1

### 6.4 Electrical connection

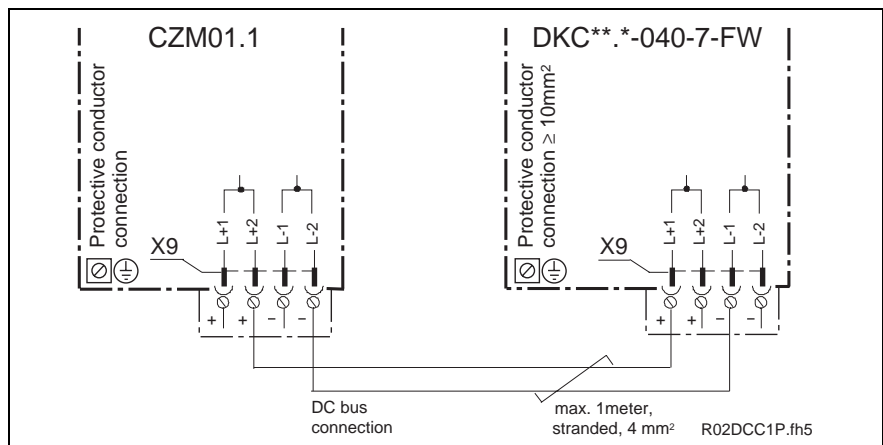

Fig. 6-8: Connecting the auxiliary capacitance module CZM01.1

## 6.5 Type code and rating plate

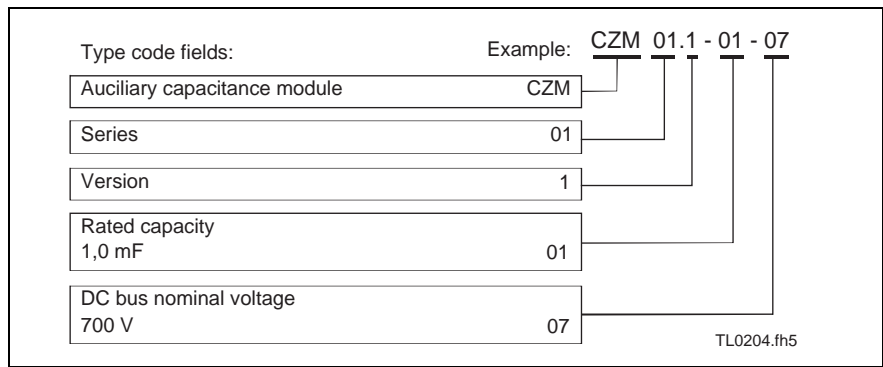

Fig. 6-9: Type code

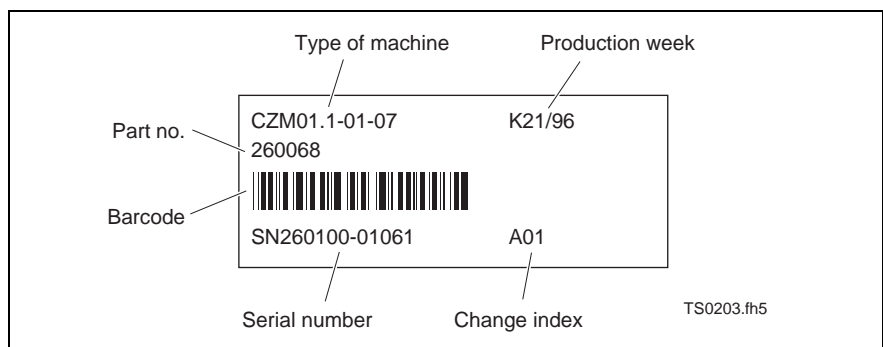

Fig. 6-10: Rating plate

**Notes**

# 7 DC24V NTM power supplies

## 7.1 Application recommendations

If there is no external DC24V control voltage available, then INDRAMAT recommends the use of NTM power supply units.

- Features**
- The power supplies contain an overvoltage safety switch with automatic shutdown. After the automatic shutdown device has responded, operation can be resumed by switching the power supply off and on again briefly.
  - The power supplies always function with a starting current limiter. However, if you switch on and off again within a period of 10 s, the starting current limit may not work!
  - The NTM01.1-024-004 and NTM01.1-024-006 power supplies make it possible to measure the voltage applied to the load via sensor cables. If there is a voltage drop, the power supply will increase the output voltage accordingly.

**Fuse protector Q2** INDRAMAT recommends a 10A automatic circuit breaker of 10 A with tripping characteristics for the DC24V NTM power supplies.

**Interference suppression** Use the line filter NFE01.1-250-006 for interference suppression.

## 7.2 Technical data

Designation	Symbol	Unit	NTM01.1-024-002	NTM01.1-024-004	NTM01.1-024-006
Nominal current of the 24 V output for the 45°C ambient temperature	$I_N$	A	2.1	3.8	5.5
Output for 45°C ambient temperature	$P_{OUT}$	W	50	100	150
Input current at 230 (115) V	$I_{IN}$	A	0.61 (1.2)	1.2 (2.2)	1.9 (3.2)
Inrush current at 230 (115) V in the mains supply lead when powering up. Make sure fuse has proper size.	$I_{EIN}$	A	32 (16)	32 (16)	32 (16)
Input voltage	$U_N$	V	Standard AC 170 to 265 by rearranging a bridge AC 85...132		
RF interference suppression filter			NFE01.1-250-006 (recommended interference suppression filter to maintain EMC values)		

TB0201.fh5

Fig. 7-1: Technical data for DC24V NTM power supplies

### 7.3 Dimensional data and installation dimensions

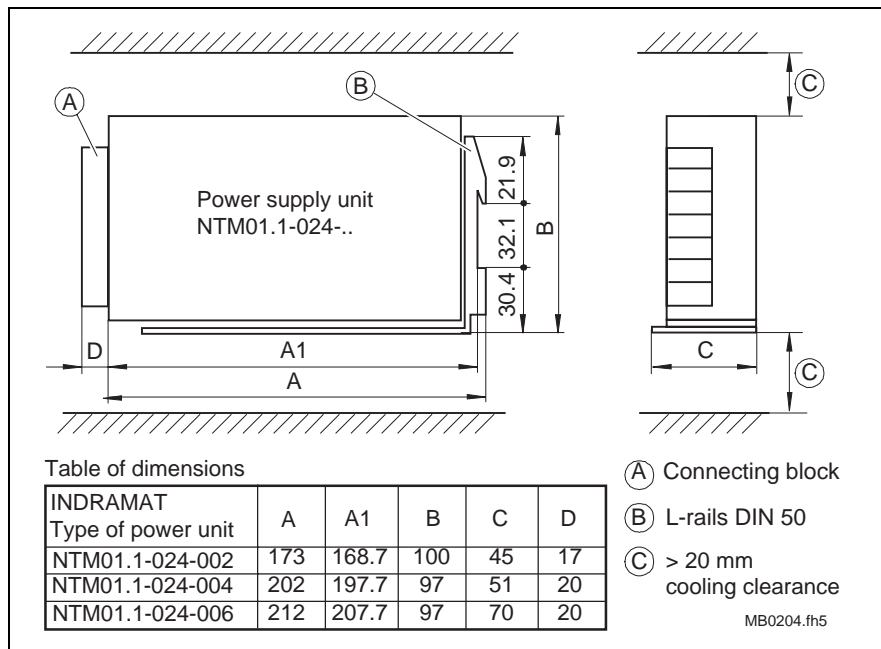

Fig. 7-2: Dimensional sheet DC24V – NTM power supplies

### 7.4 Front views

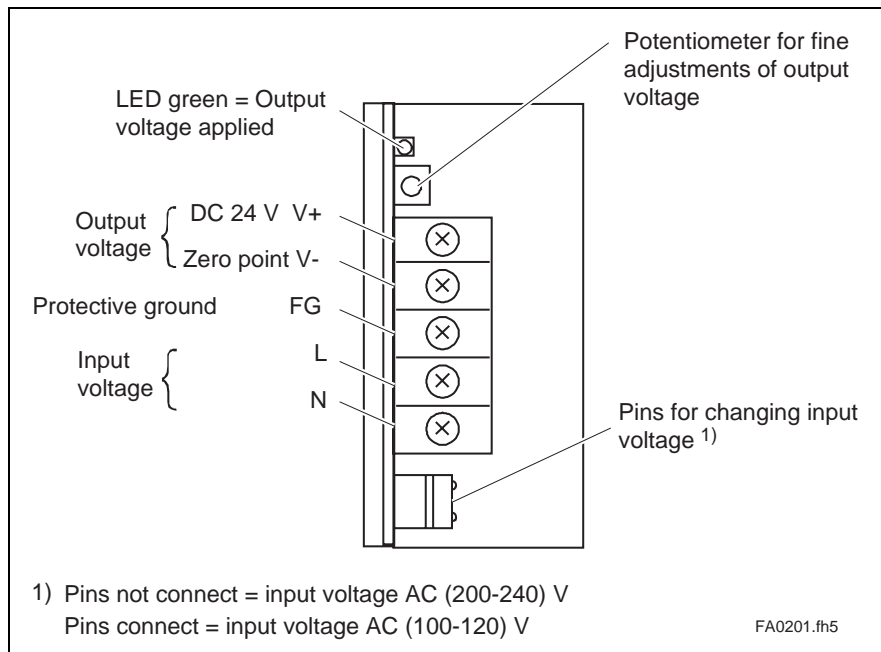

Fig. 7-3: Front view and terminal designations of the power supply NTM01.1-024-002



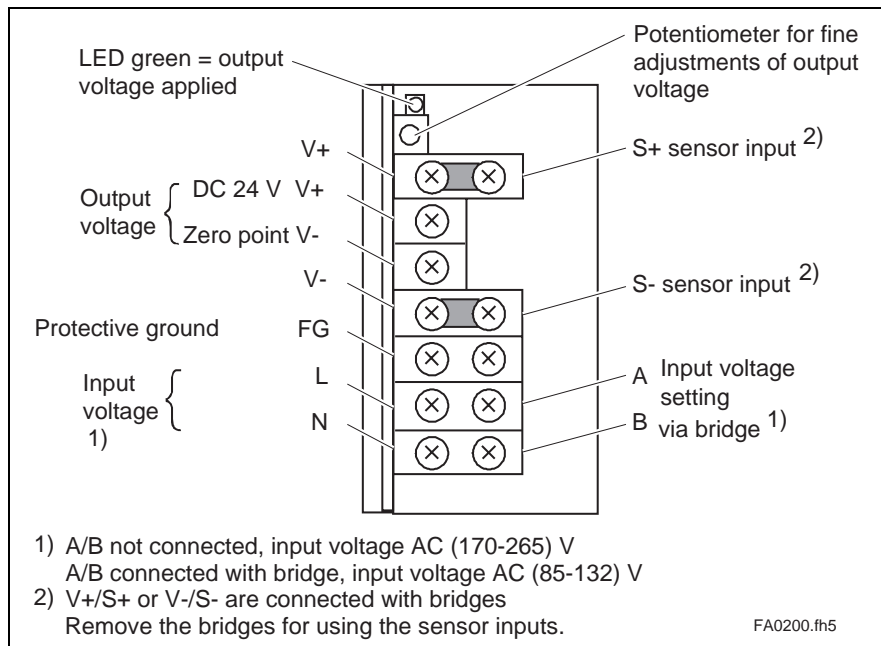

Fig. 7-4: Front view and terminal designation of the power supplies NTM01.1-024-004 and NTM01.1-024-006

## 7.5 Electrical connection

Always use the NTM together with the line filter NFE01.1-230-006.

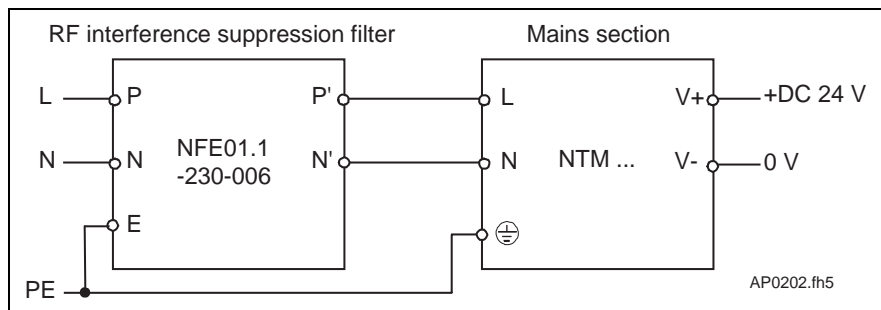

Fig. 7-5: Connecting the power supply to a line filter

**Note:** The bridge circuits V+/S+ and V-/S- must be removed if sensor inputs are used.

**Note:** The 0 V connection on the secondary side of 24V power supplies is always attached to the central reference ground point in the control cabinet (see Chap. 8.3)

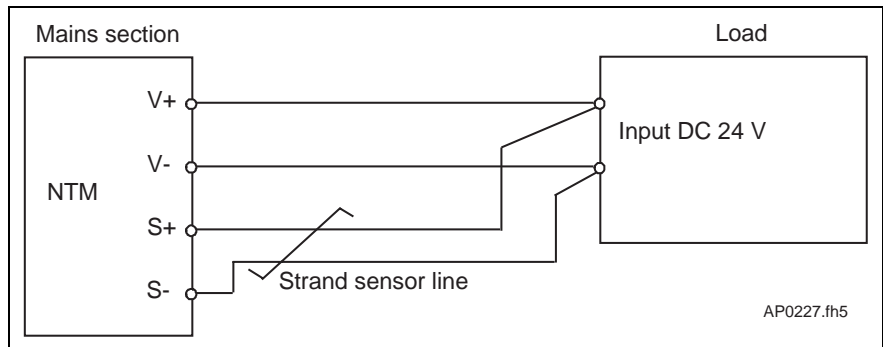

Fig. 7-6: Connecting the sensor cables NTM01.1-024-004 and NTM01.1-024-006

## 7.6 Type code

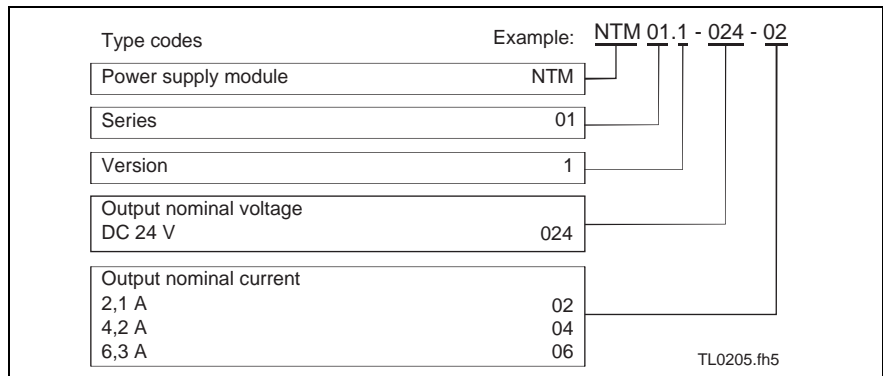

Fig. 7-7: Type code

# 8 NFD / NFE line filter

## 8.1 Selection

The filters listed here are designed for the DKC drive controller power connection.

Please see Chap. 8.4 for information on the line filter for interference suppression on the DC24V NTM power supply.

Max. line power connection voltage of the 50..60 Hz $U_N$ in V	Rated line current $I_{Netz}$ (1) in A	No. of phases	Type of line filter (degree of protection IP10)	Supply terminals		Brush shunt		Power dissipation in W	Weight n kg
				mm <sup>2</sup>	AWG	mm <sup>2</sup>	AWG		
AC 480 V +10%	7,5	3	NFD 02.1-460-008	6	AWG 10	-----	-----	8,7	1,5
AC 480 V +10%	16	3	NFD 02.1-480-016	6	AWG 10	1,34	16	9	1,7
AC 480 V +10%	30	3	NFD 02.1-480-030	10	AWG 6	5,37	10	14	1,8
AC 480 V +10%	55	3	NFD 02.1-480-055	10	AWG 6	6	13,5	20	3,1
AC 480 V +10%	75	3	NFD 02.1-480-075	25	AWG 3	-----	-----	20	4
AC 480 V +10%	130	3	NFD 02.1-480-130	50	AWG 1/0	-----	-----	40	7,5
AC 480 V +10%	180	3	NFD 02.1-480-180	95	AWG 4/0	-----	-----	61	11
AC 230 V +10%	7,5	1	NFD 02.1-230-008	6	AWG 10	-----	-----	7,2	1,1

(1) = max. continuous current at the power connection at an ambient temperature of 45°C

Fig. 8-1: Technical data of the available line filters

### Technical Data

<b>Operating frequency</b>	from DC to 60 Hz at 40 °C
<b>Power dissipation</b>	measured 2 or 3 x R I <sub>Nenn DC</sub> <sup>2</sup>
<b>Temperature range</b>	-25 ...+ 85 °C
<b>Overload</b>	1.5 I <sub>Nenn</sub> 1 min per hour
<b>Saturation reaction</b>	Reduction of the filter attenuation by 6 dB at 2.5 to 3 times the rated current.
<b>Test voltage</b>	L/N -> PE or L -> PE: 2800 V <sub>DC</sub> 2 s at 25 °C L -> PE or L -> L: 2125 V <sub>DC</sub> 2 s or 25 °C
<b>Current reduction at excess temperatures</b>	$I = I_N * \sqrt[2]{(85 - \Theta) / 40}$ ; $\Theta$ Ambient temperature in °C ; I <sub>N</sub> in reference to 45°C
<b>Degree of protection</b>	IP 10

Fig. 8-2: Ambient and operating conditions

## 8.2 Dimensional data and installation dimensions

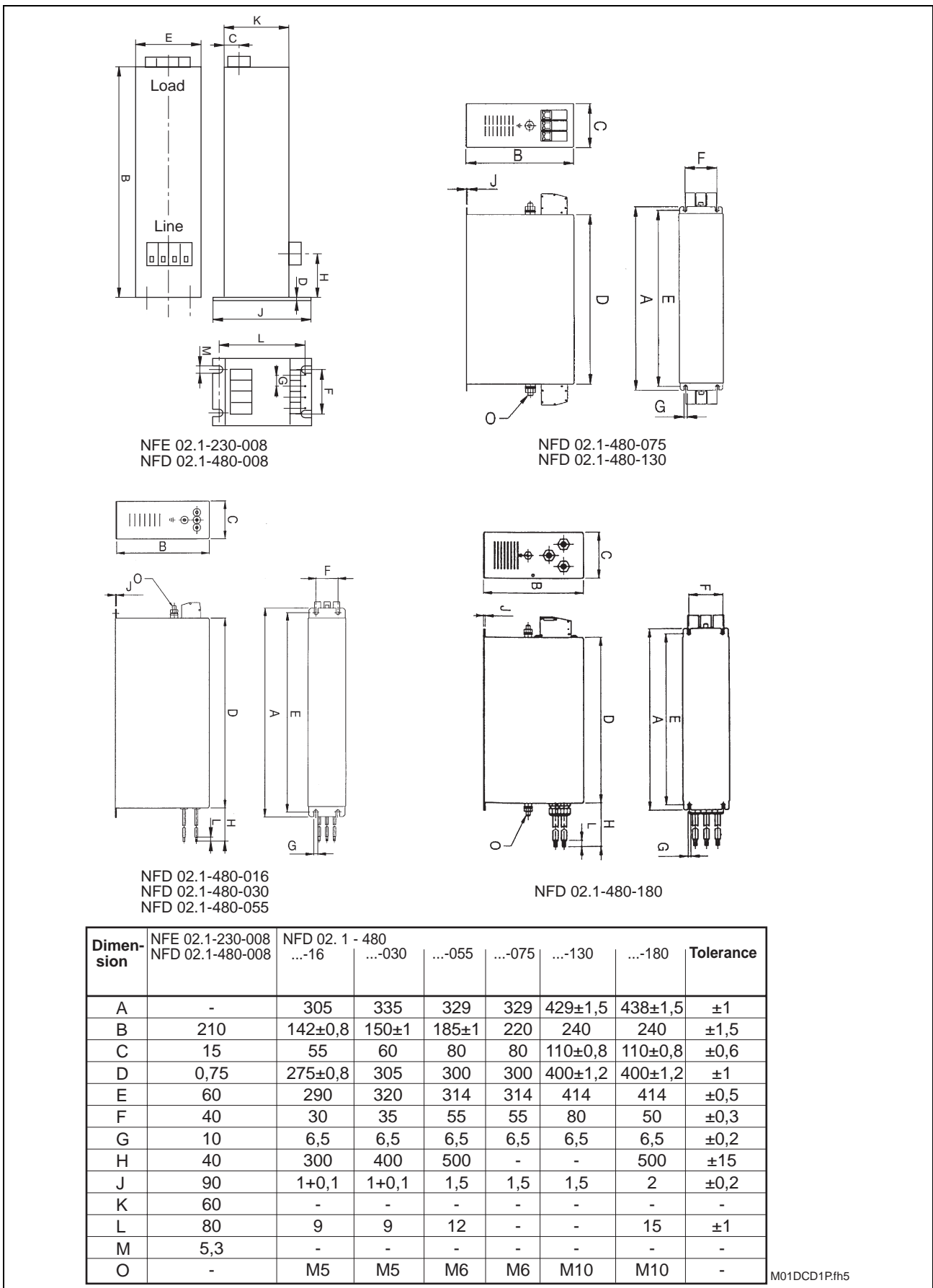

Fig. 8-3: Dimensional data, installation dimensions of the NFD, NFE line filters

Notes on assembly

The mounting plate or the control cabinet housing to which the DKC is mounted are the preferred locations for assembly.



**Live parts (greater than 50 V)!**

Electric shock on contact!

- ⇒ Before startup operation, the protective ground conductor must first be permanently connected to the filter and then grounded!
- ⇒ Before touching bare connection lines and terminals, isolate the filter with the connected terminals or disconnect it. Allow time for discharging! Do not work on connecting cables until then!
- ⇒ Due to the high discharge current of the filter, operation is not permitted without a connected protective conductor!
- ⇒ This is why the filter may only be operated with a permanently connected protective conductor with a cross section  $\geq 10 \text{ mm}^2$ !
- ⇒ Remove any paint or coatings from the mounting points of the filter.
- ⇒ Use a tooth-lock washer with galvanized or tin-plated screws.

### 8.3 Electrical connection

To assemble and install the line filters, observe the recommendations in the documents

"EMC in Drive and Control Systems"

- Project Planning Manual -

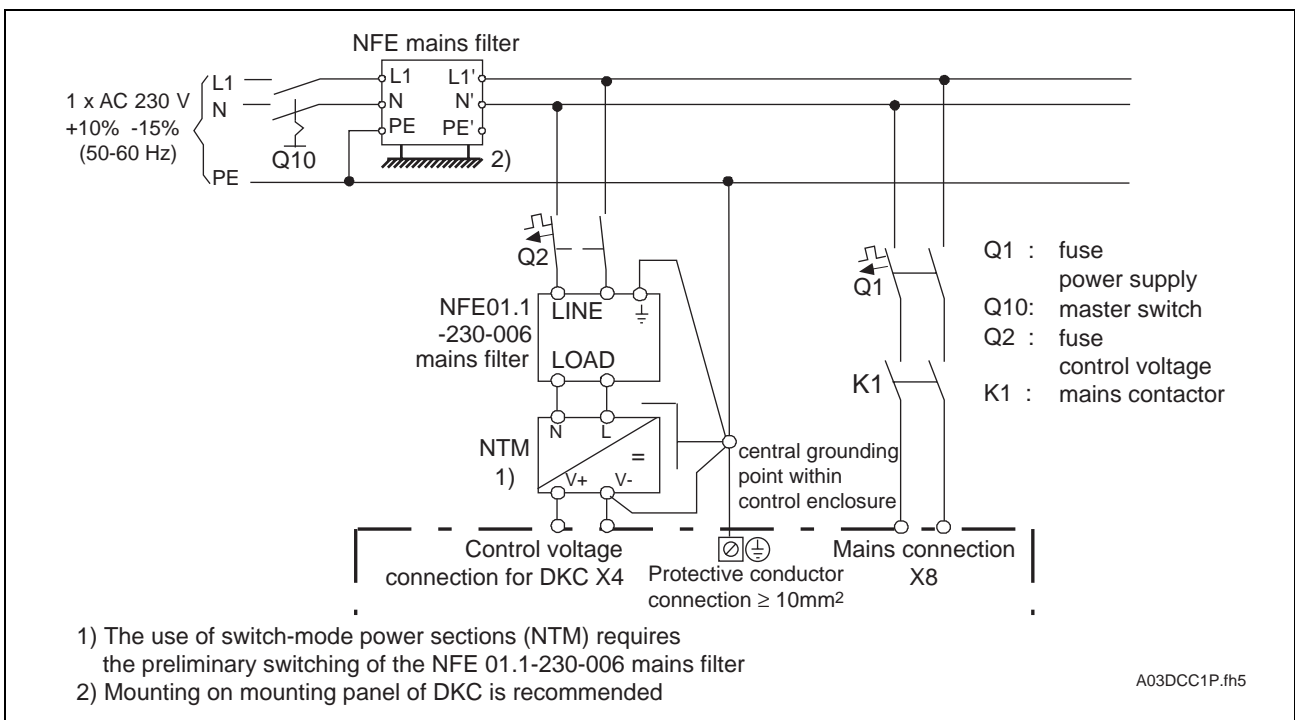

Fig. 8-4: Single-phase line filter connection with NFE02.1-230-008

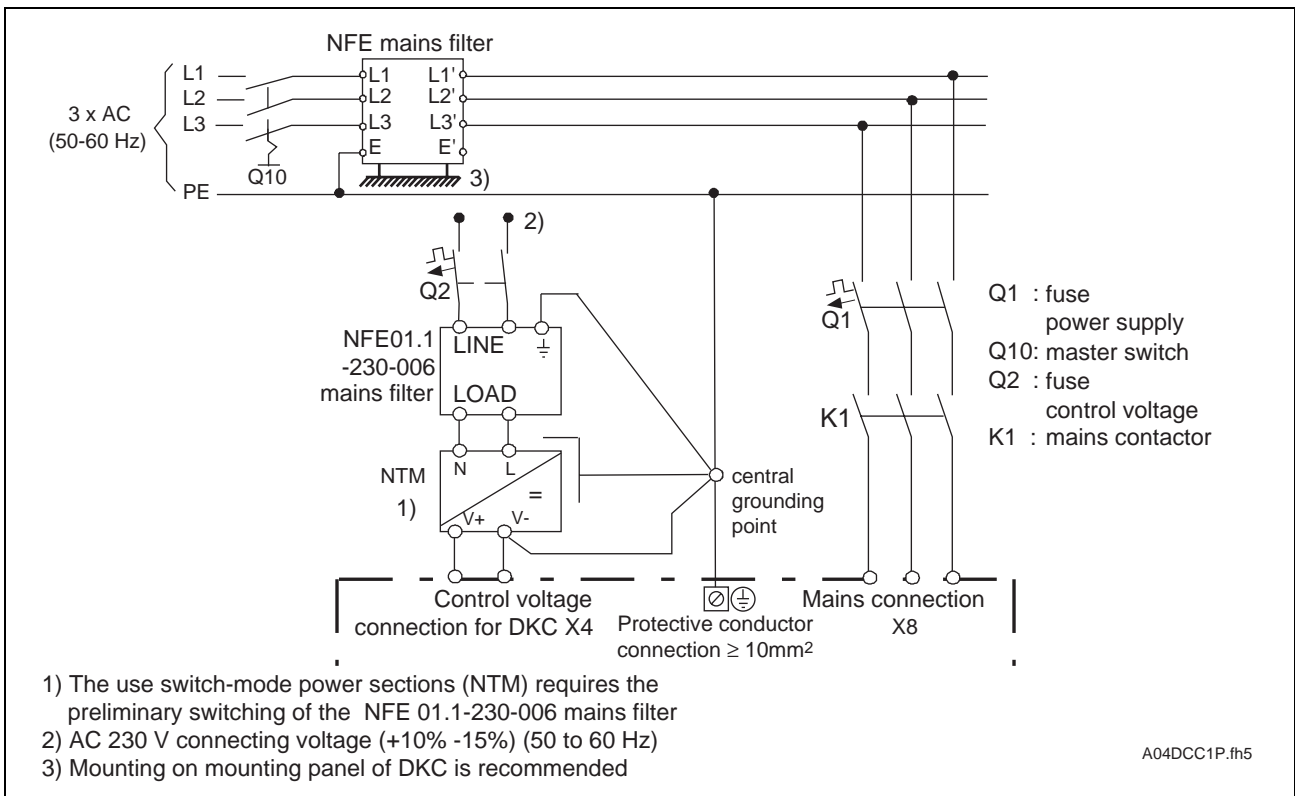

Fig. 8-5: Three-phase line filter connection with NFD01.1 or NFD02.1

### 8.4 Line filters for DC24V NTM power supplies

When using the NTM power supply, use the NFE01.1-250-006 line filter for interference suppression.

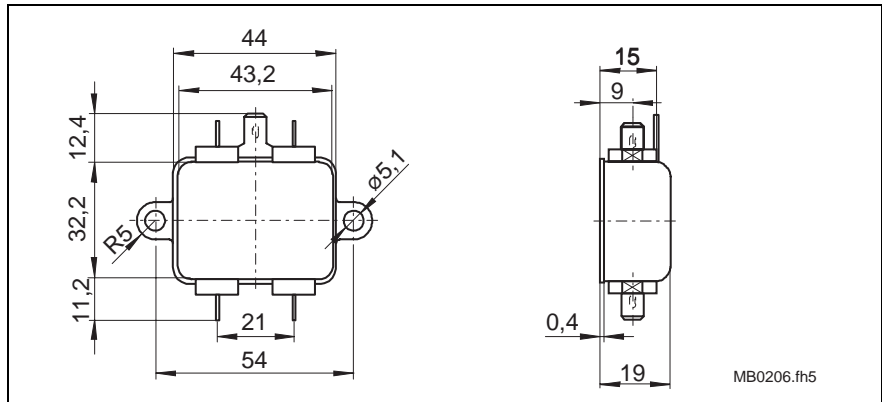

Fig. 8-6: Dimension drawing: Line filter NFE01.1-250-006

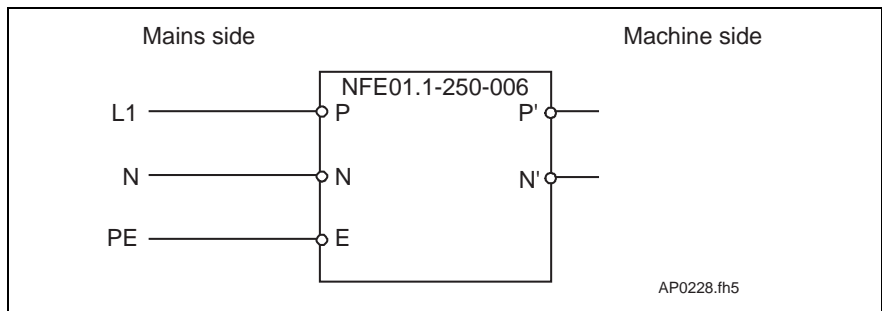

Fig. 8-7: Contact assignment of the line filter NFE01.1-250-006

The line filter is connected via 6.3-1 tab receptacles in accordance with DIN 462 545.

### 8.5 Type code

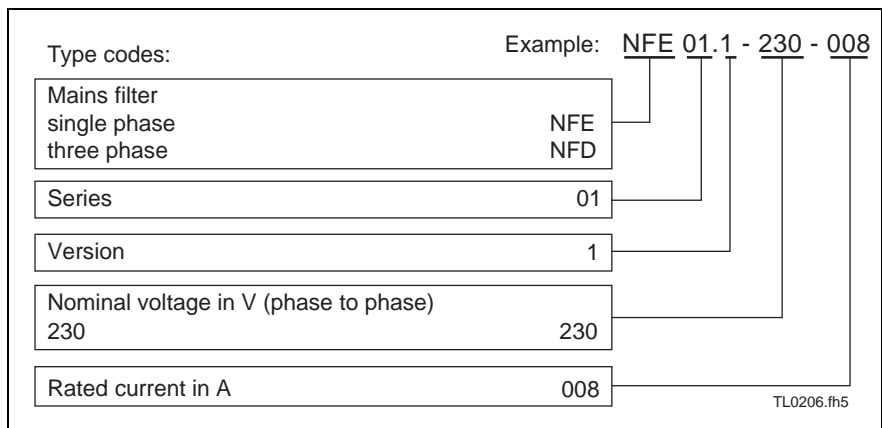

Fig. 8-8: Type code

## Notes



## 9 DST / DLT transformers

### 9.1 Selection

Transformers are only needed if the line voltage exceeds the permitted rated voltage of the DKC.

#### Grounded power supply lines

For grounded power supply lines, the line voltage is matched to the rated voltage of the unit using autotransformers:

- for DKC\*\*.\*-040-7-FW/DKC11.1-040-7-FW with autotransformers suitable for a specific **output voltage range**.
- for DKC\*\*.\*-030-3-F with autotransformers designed for a specific **output voltage**.

#### Ungrounded power supply lines

To match the voltage for grounded power supply lines, always connect isolating transformers to prevent excess voltages between the outer conductor and ground.

- for the DKC\*\*.\*-040-7-FW this documentation does not offer a range of products for selecting suitable isolating transformers (Unterlage bei Bedarf anfordern).
- for the DKC\*\*.\*-030-3-FW the isolating transformer can be selected according to Fig. 9-4.

### 9.2 Autotransformers for DKC\*\*.\*-040-7-FW

Select an autotransformer according to the line voltage and the power requirements of the system.

Proceed with the selection as follows:

- ⇒ Determine the rating group and read the gearing ratio "i" using the required rated line voltage range from the diagram in Fig. 9-1.
- ⇒ Calculate the actual transformer output voltage using the rated line voltage and the gearing ratio "i".
- ⇒ Check drive data. The output voltage of the transformer affects the drive data. See documentation "ECODRIVE Servodrives DKC with MKD"- Selection lists.
- ⇒ Select a three-phase autotransformer via the required connected load.

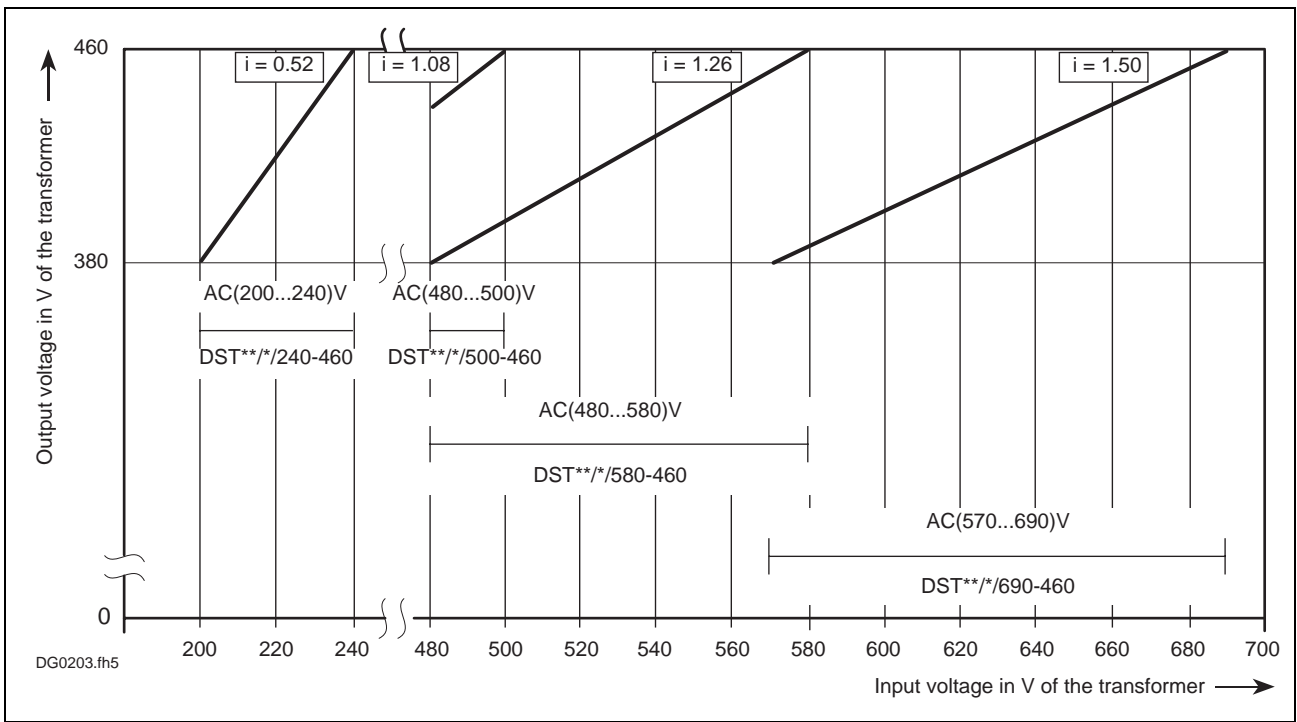
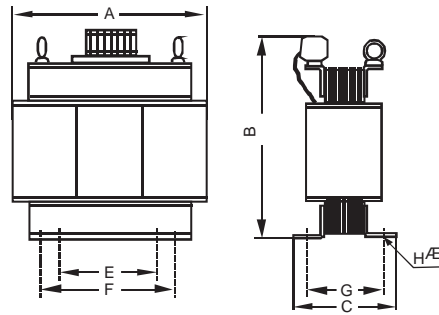

Fig. 9-1: Classification of three-phase autotransformers into rating groups

DST autotransformer with secondary or output voltage AC (380 to 460) V

Standing version for mounting with base: DST.../S



Rating plate (example)

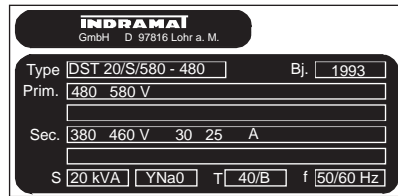

Block diagram

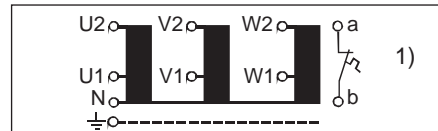

1) Temperature switch max. load: DC 24V/1A; AC 230V/1A

Type designation DST...	Conn. output in KVA	Transmission ratio	Dimensions in mm							Power loss in W	max. conn. dia. in mm <sup>2</sup>	Weight in kg
			A	C	B	F	E	G	H $\varnothing$			
Input voltage: AC (200...240) V $\pm$ 10%												
4/S/240-460	4		240	150	260	170	110	120	11	120	10	24.5
7,5/S/240-460	7.5		335	175	365	230	160	145	11	225	10	55
12,5/S/240-460	12.5	0.52	360	190	395	250	170	160	11	310	10	70
25/S/240-460	25		480	195	500	356	-----	158	13	500	35	135
50/S/240-460	50		580	265	540	400	270	215	18	750	70	195
Input voltage: AC (480...500) V $\pm$ 10%												
4/S/500-460	4		180	105	190	125	80	75	7	160	4	8.5
7,5/S/500-460	7.5		205	130	210	145	95	95	7	260	4	13
12,5/S/500-460	12.5	1.08	240	140	260	170	110	110	11	440	10	22
25/S/500-460	25		300	155	325	210	140	125	11	750	16	36
50/S/500-460	50		335	175	365	230	160	145	11	1050	35	53
Input voltage: AC (480...580) V $\pm$ 10%												
4/S/580-460	4		240	130	260	170	110	100	11	140	4	18
7,5/S/580-460	7.5		240	140	260	170	110	110	11	260	4	22
12,5/S/580-460	12.5	1.26	300	155	325	210	140	125	11	375	10	37
25/S/580-460	25		360	190	395	250	170	160	11	625	10	72
50/S/580-460	50		420	215	450	280	190	155	14	1000	35	95
Input voltage: AC (570...690) V $\pm$ 10%												
4/S/690-460	4		240	140	260	170	110	110	11	140	10	22
7,5/S/690-460	7.5		300	155	325	210	140	125	11	225	10	37
12,5/S/690-460	12.5	1.5	335	175	365	230	160	145	11	375	10	57
25/S/690-460	25		420	205	450	280	190	145	14	500	16	88
50/S/690-460	50		480	222	500	356	-----	185	13	750	35	178

MB0207.fh5

Fig. 9-2: DST autotransformers for the DKC\*\*.1-40-7-FW to match the line voltage

### 9.3 Autotransformers for DKC\*\*.\*-030-3-FW

DST autotransformers with a secondary or output voltage of AC 220...230V

Standing version for foot mounting type: DST.../S

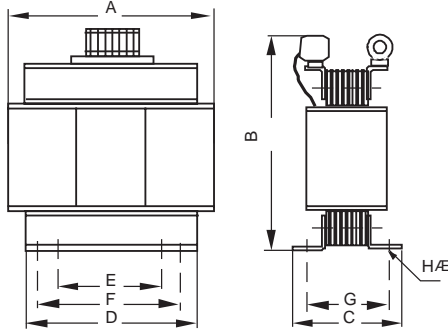

Lying version for wall mounting type DST.../L

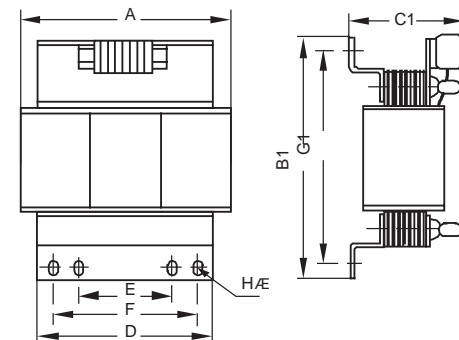

Rating plate (example)

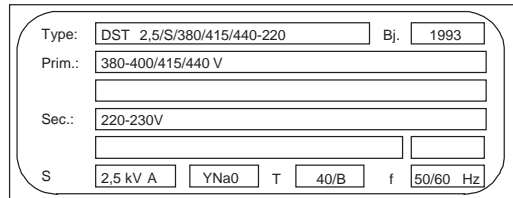

Connection diagram

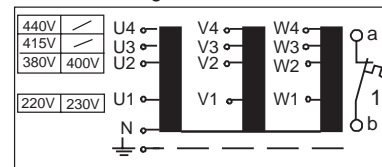

1) Max. loading of temperature switch:  
DC 24V/1A; AC 230V/1A

Type designation DST	Dimensions in mm											Power dissipation in W	Max. connec. in cross sect. in mm	Wght. in kg
	A	B	B1	C	C1	D	E	F	G1	HÆ	G			
0,5/ /380/415/440-220	150	165	170	75	80	125	70	100	154	6	55	30	4	4
0,5/ /380/460/500-220	150	165	170	90	95	125	70	100	154	6	70	40	4	6
1,0/ /380/415/440-220	180	190	205	105	100	125	80	125	185	7	75	45	4	8,5
1,0/ /380/460/500-220	180	190	205	115	100	150	80	125	185	7	85	55	4	10
1,5/ /380/415/440-220	180	190	205	115	110	150	80	125	185	7	85	55	4	10
1,5/ /380/460/500-220	205	210	235	120	110	150	95	145	209	7	85	75	4	11,5
2,0/ /380/415/440-220	205	210	235	120	110	170	95	145	209	7	85	80	4	11,5
2,0/ /380/460/500-220	240	260	270	120	135	200	110	170	240	11	90	90	4	18
2,5/ /380/415/440-220	240	260	270	120	135	200	110	170	240	11	90	95	4	18
2,5/ /380/460/500-220	240	260	270	140	155	200	110	170	240	11	110	110	4	21
3,5/ /380/415/440-220	240	260	270	140	155	200	110	170	240	11	110	125	10	21
3,5/ /380/460/500-220	240	260	270	150	165	200	110	170	240	11	120	130	10	24,5
4,0/ /380/415/440-220	240	260	270	150	165	200	110	170	240	11	120	140	10	24,5
4,0/ /380/460/500-220	240	260	270	155	170	200	110	170	240	11	125	150	10	26
5,0/ /380/415/440-220	240	260	270	155	170	200	110	170	240	11	125	160	10	26
5,0/ /380/460/500-220	300	325	340	140	165	250	140	210	310	11	110	180	10	30,5
7,5/ /380/415/440-220	300	325	340	155	180	250	140	210	310	11	125	200	10	36
7,5/ /380/460/500-220	300	325	340	165	195	250	140	210	310	11	135	230	10	42
10/ /380/415/440-220	300	325	340	180	205	250	140	210	310	11	150	245	10	50
10/ /380/460/500-220	300	325	340	195	220	250	140	210	310	11	165	250	10	53
12,5/ /380/415-220	300	325	340	195	220	250	140	210	310	11	165	260	10	53
12,5/ /440/460-220	335	365	380	195	225	280	160	230	350	11	160	270	10	65
12,5/ /500/525-220	335	365	380	195	225	280	160	230	350	11	160	285	10	65
15/ /380/415-220	335	365	380	195	225	280	160	230	350	11	160	290	16	65
15/ /440/460-220	360	395	400	190	215	300	170	250	370	11	160	305	16	68
15/ /500/525-220	360	395	400	190	215	300	170	250	370	11	160	310	16	68
18/ /380/415-220	360	395	400	190	215	300	170	250	370	11	160	330	16	68
18/ /440/460-220	360	395	400	205	230	300	170	250	370	11	175	350	16	80
18/ /500/525-220	360	395	400	205	230	300	170	250	370	11	175	375	16	80
20/ /380/415-220	360	395	400	190	215	300	170	250	370	11	160	380	16	70
20/ /440/460-220	360	395	400	205	230	300	170	250	370	11	175	395	16	80
20/ /500/525-220	420	450	460	215	210	350	190	280	420	14	165	430	16	92

· = L, lying version  
· = S, standing version

MB0208.fh5

Fig. 9-3: Three-phase autotransformers for the DKC01.1-030-3-FW for connecting to power supply lines > 230 V

DST autotransformers with a secondary or output voltage of AC 220...230V

Standing version for foot mounting type: DST.../S

Lying version for wall mounting type DST.../L

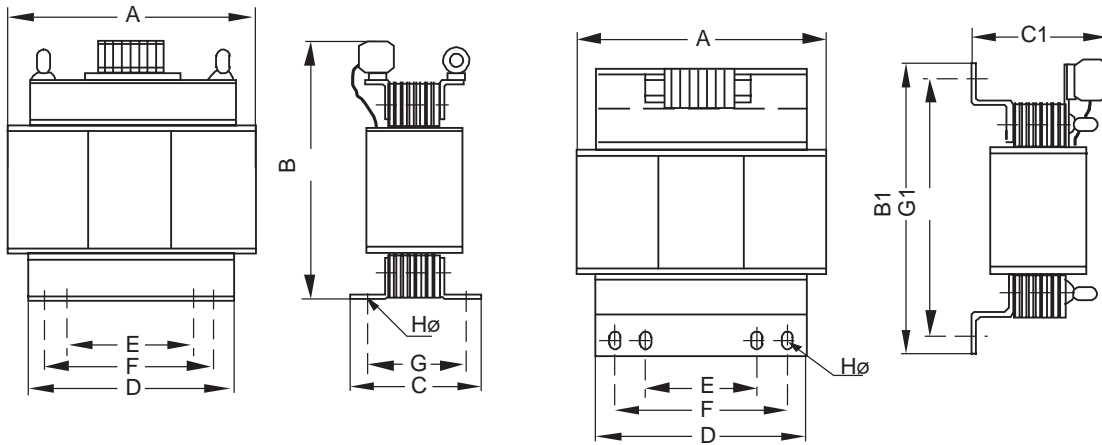

Rating plate (example)

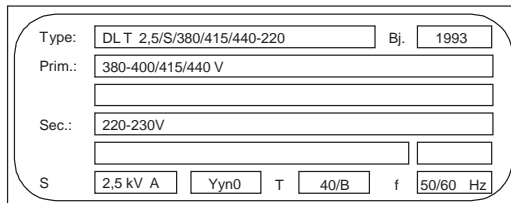

Connection diagram

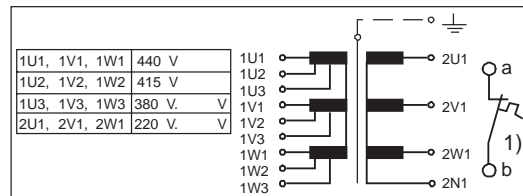

1) Max. loading of temperature switch:  
DC 24V/1A; AC 230V/1A

Type designation DLT	Dimensions in mm											Power dissipation in W	Max. connec. in cross sect. in mm <sup>2</sup>	Wght. in kg
	A	B	B1	C	C1	D	E	F	G	G1	Hø			
0,5/ · /380/415/440-220	180	190	205	105	100	150	80	125	75	185	7	65	4	8,5
0,5/ · /380/460/500-220	180	190	205	105	100	150	80	125	75	185	7	70	4	8,5
1,0/ · /380/415/440-220	205	210	235	130	120	170	95	145	95	209	7	120	4	13
1,0/ · /380/460/500-220	205	210	235	130	120	170	95	145	95	209	7	140	4	13
1,5/ · /380/415/440-220	240	260	270	140	155	200	110	170	110	240	11	155	4	21
1,5/ · /380/460/500-220	240	260	270	140	155	200	110	170	110	240	11	165	4	21
2,0/ · /380/415/440-220	240	260	270	150	165	200	110	170	120	240	11	180	4	24,5
2,0/ · /380/460/500-220	240	260	270	150	165	200	110	170	120	240	11	195	4	24,5
2,5/ · /380/415/440-220	300	325	340	140	165	250	140	210	110	310	11	220	4	30,5
2,5/ · /380/460/500-220	300	325	340	140	165	250	140	210	110	310	11	235	4	30,5
4,0/ · /380/415/440-220	300	325	340	165	195	250	140	210	135	310	11	240	10	42
4,0/ · /380/460/500-220	300	325	340	165	195	250	140	210	135	310	11	265	10	42
5,0/ · /380/415/440-220	335	365	380	175	210	280	160	230	145	350	11	300	10	55
5,0/ · /380/460/500-220	335	365	380	175	210	280	160	230	145	350	11	350	10	55
7,5/ · /380/415/440-220	360	395	400	190	215	300	170	250	160	370	11	375	10	70
7,5/ · /380/460/500-220	360	395	400	190	215	300	170	250	160	370	11	395	10	70
10/ · /380/415/440-220	360	395	400	205	230	300	170	250	175	370	11	500	10	85
10/ · /380/460/500-220	360	395	400	205	230	300	170	250	175	370	11	510	10	85
15/ · /380-220	420	450		245		350	190	280	195		16	600	16	122
20/ · /380-220	420	450		275		400	190	280	225		16	800	35	152

- = L, lying version  
- = S, standing version

MB0209.fh5

Fig. 9-4: Three-phase isolating transformer documentation for the DKC01.1-030-3-FW for connecting to power supply lines > 230 V (ungrounded power supply lines)

### 9.4 Electrical connection of the DKC via transformer

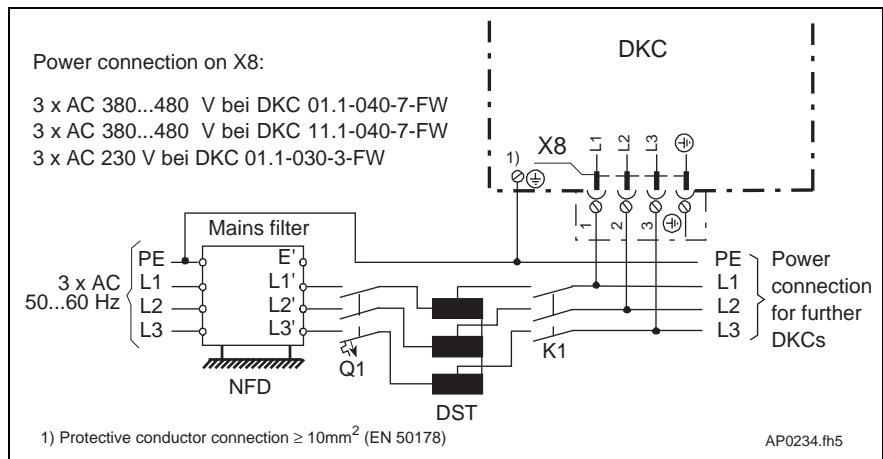

Fig. 9-5: Power connection via a three-phase autotransformer

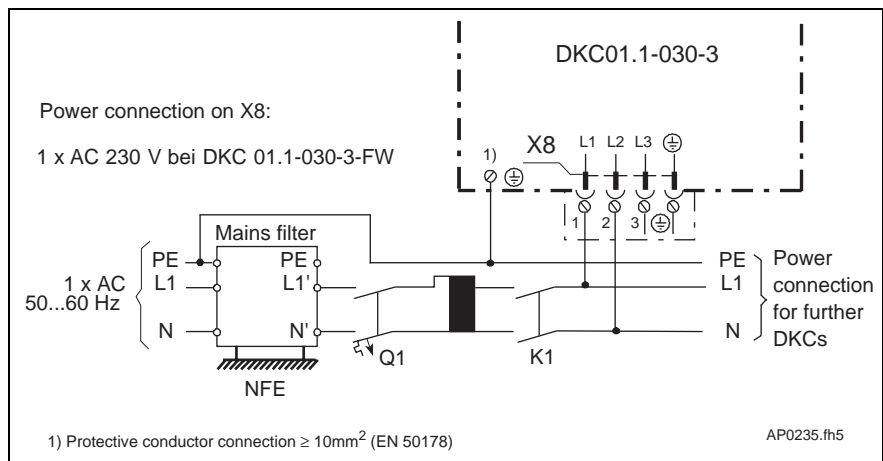

Fig. 9-6: Direct power connection via single-phase via autotransformer

## 9.5 Type code

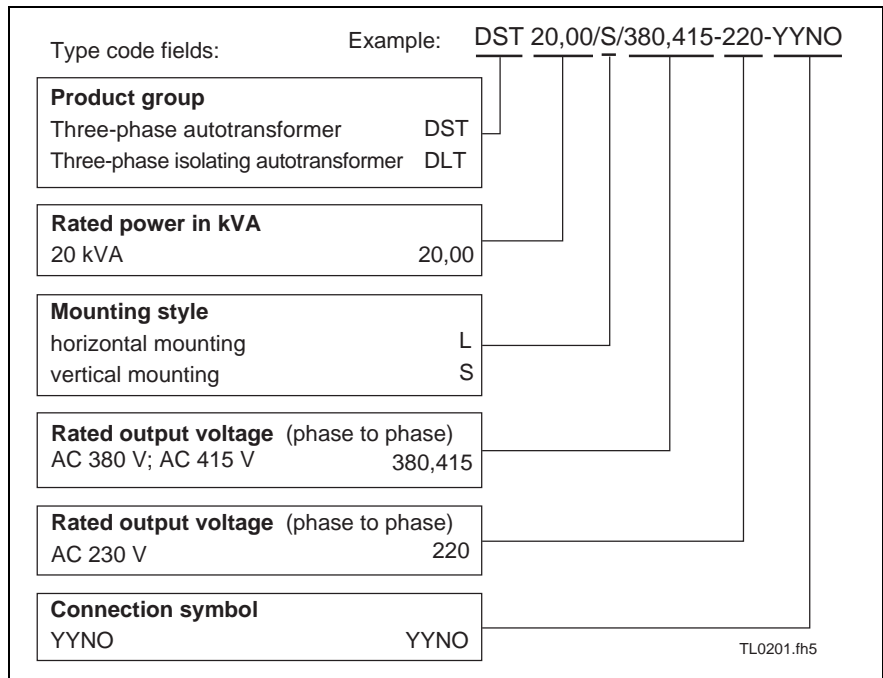

Fig. 9-7: Type code for transformers

## Notes



## 10 Planning the control cabinet

### 10.1 Notes on installing the control cabinet

All ECODRIVE drive components -- with the exception of the motors -- are designed to be installed into a control cabinet. When planning the control cabinet, it is necessary to take the technical data of the drive components into account.

#### Power dissipation

Power dissipation is determined by the current load and the continuous regenerative power. The actual power dissipation is dependent on the respective cycle load. The servomotor implemented has been laid out for this load cycle.

On the average, the continuous current at standstill  $I_{dN}$  will flow through the drive controller as a maximum value.

#### Determining power dissipation

- ⇒ See the respective document "ECODRIVE Servomotors MKD" - Project Planning - for the continuous current at standstill  $I_{dN}$ .
- ⇒ Using the  $I_{dN}$  value of the motor selected, find the value in the diagram in Fig. 10-1 for the current-dependent power dissipation  $P_{V,DKC}$ .
- ⇒ Convert the continuous regenerative power found in Tab. Fig. 3-2 with the factor 0.8. as bleeder-dependent power dissipation  $P_{V,Bleeder}$  in the DKC.
- ⇒ Add both dissipation values ( $P_{V,DKC}$  and  $P_{V,Bleeder}$ ). Use the total ( $P_{V,ges}$ ) for planning the control cabinet.

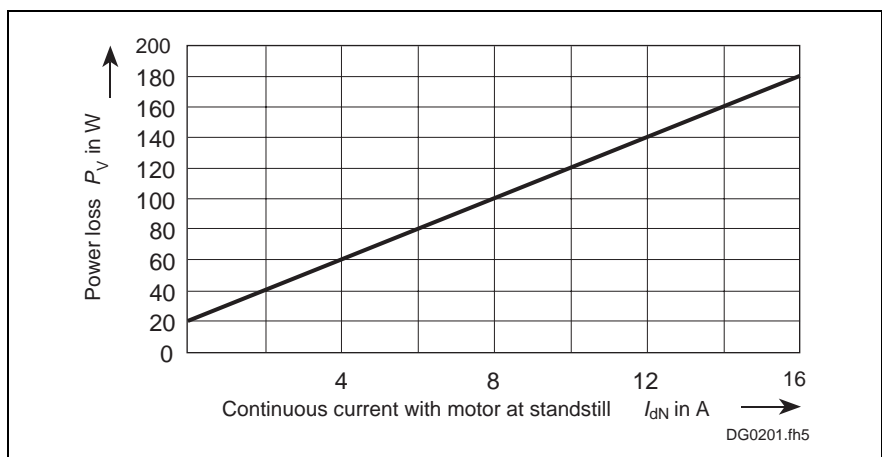

Fig. 10-1: Determining the power dissipated in the control cabinet

## 10.2 Using heat-exchange units in the control cabinets

Improperly installed and operated heat-exchange units are a risk to the drive components installed in the control cabinet due to the condensation and condensed water which these may cause!

<b>Risk of condensation</b>	Humid air enters the cabinet and, as it cools, condenses onto the installed drive components.
<b>Risk of condensation</b>	If the heat-exchange unit is not properly installed in the control cabinet, accumulating condensed water can drip into the installed drive components or be sprayed into them by the cold air current.
<b>Avoiding condensation</b>	<p>Proper use of the heat-exchange units:</p> <ul style="list-style-type: none"><li>• When using heat heat-exchange units, the cabinets must be well sealed so that moisture cannot form caused by humid outside air entering the cabinets!</li><li>• In the event that the control cabinets are operated with open doors (startup operation, servicing, etc.), ensure that the drive components are never cooler than the air in the control cabinets after the doors have been closed. Otherwise, condensation may occur. For this reason, it is important that the heat-exchange unit continues to operate when the system has been shut down to ensure that temperature within the control cabinet does not deviate from that of the drive components.</li><li>• Set the heat-exchange unit to a permanent temperature of 40 °C. Not lower!</li><li>• Heat-exchangers with follow-up temperature must be set so that the temperature inside the cabinet is never lower than the outside temperature. Set the temperature limit to 40 °C!</li></ul>
<b>Avoiding dripping and sprayed water</b>	<p>The heat-exchange units must be arranged in such a way that condensed water that may accumulate cannot drip into the installed drive components. Units on top of the cabinet require a special design!</p> <p>Make sure that the control cabinet is constructed in such a way that the blower of the cooling unit cannot spray condensed water which may have collected, onto the drive components!</p>
<b>Summary</b>	<ul style="list-style-type: none"><li>• Ensure that no condensed water can drip into the installed drive components!</li><li>• Make sure that the temperature of the heat-exchange unit has been properly set!</li></ul>

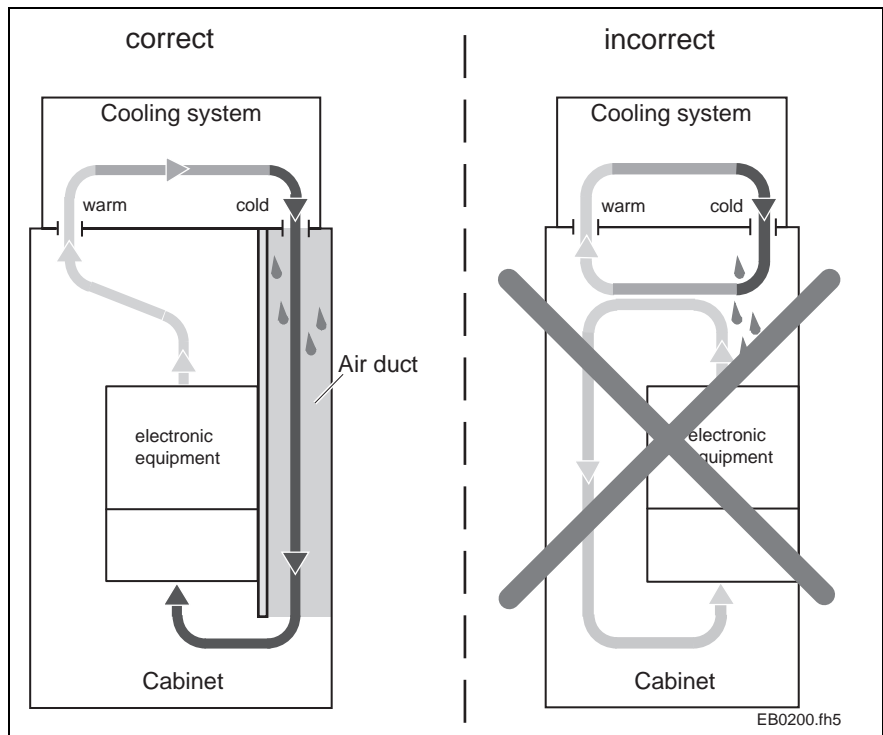

Fig. 10-2: Arranging the heat-exchange unit on the top of the control cabinet

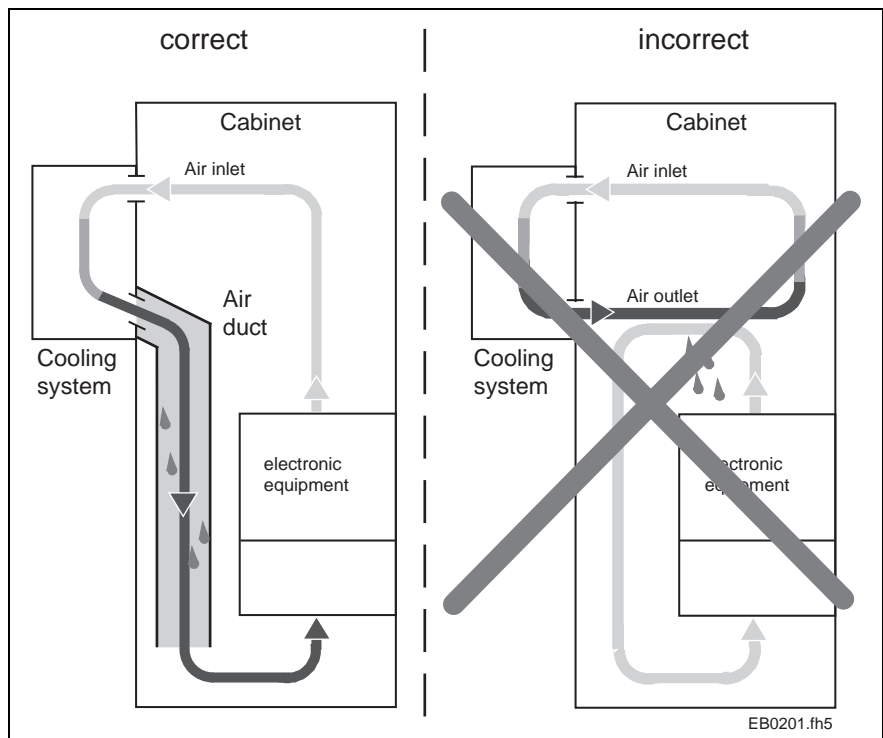

Fig. 10-3: Arranging the heat-exchange unit at the front of the control cabinet

## Notes

# 11 Power connection

## 11.1 Direct power connection

**DKC01.1-040-7-FW  
DKC11.1-040-7-FW**

It is possible to connect these drives directly to grounded three-phase current lines with AC 380...480 V, +10 %. Only a fuse protector Q1, a mains contactor K1, and normally a line filter are required in the power input line.

If the line voltage exceeds the permitted input voltage range, then the voltage must be matched by means of an autotransformer which, in turn, has also been laid out for a specific voltage range (see Chapter 9-1).

**DKC01.1-030-3-FW**

It is possible to connect these drives directly to grounded three-phase current lines with 3 x AC 230 V, +10 %. A single-phase power connection 1 x AC 230V is possible for small amounts of power.

Only a fuse protector Q1, a line contactor K1, and normally a line filter are required in the power input line.

If the line voltage deviates from the permitted input voltage, the voltage is usually matched using an autotransformer or for special line conditions, using an isolating transformer (see Chapter 9-1).

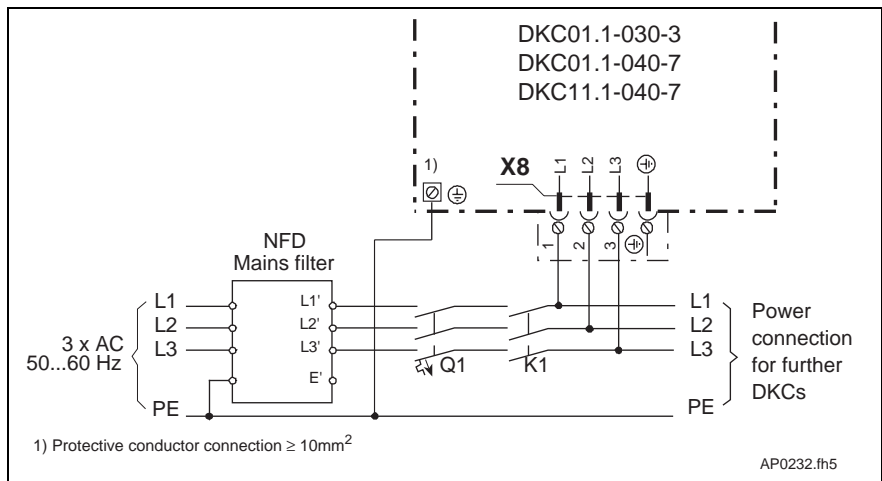

Fig. 11-1: Direct three-phase power connection

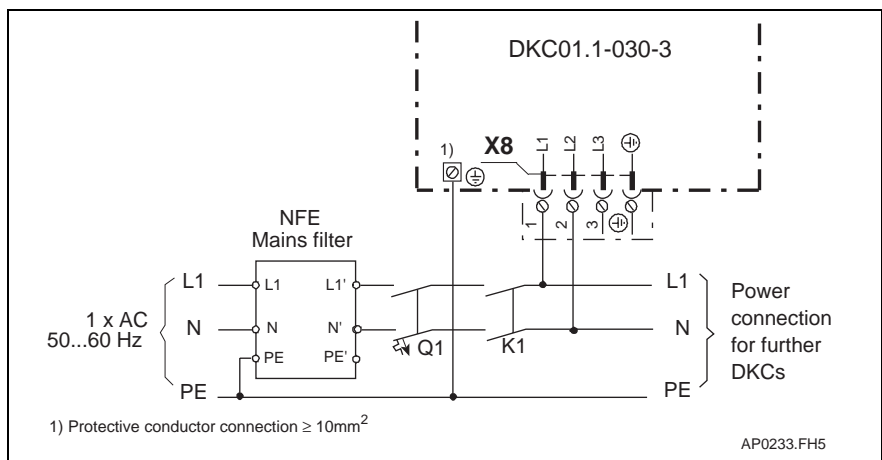

Fig. 11-2: Direct single-phase power connection

## 11.2 Line contactor/fuse protector

A selection table (see Fig. 11-6) is available to facilitate the selection of a suitable line contactor and fuse protector device for the power connection.

### Calculating the phase current at the power connection

To be able to select a suitable line contactor and suitable power connection fuse protector, the phase current  $I_N$  at the power connection must first be calculated.

The apparent power  $S$  is used to determine the phase current  $I_N$  at the power connection.

Locate the apparent power in the selection table of the drive components, or calculate it according to formula Fig. 11-4. For several drive controllers, add the individual apparent power values.

$$P_{DC} = \frac{M_{EFF} \cdot n_{MITTEL} \cdot 2\pi}{60} \cdot k$$

$P_{DC}$ : DC bus power in W  
 $M_{EFF}$ : Effective torque in Nm  
 $n_{MITTEL}$ : Average speed in min-1  
 $k$ : Factor for motor and controller efficiency = 1.25

Fig. 11-3: Calculating the DC bus power

$$S_{AN} = P_{DC} \cdot F$$

$F$ : Factor for the connected load  
 $F$ : 2.6 for  $P_{DC} = 500$  W  
 $F$ : 1.95 for  $P_{DC} = 2000$  W

Fig. 11-4: Calculating the power connection output

Single-phase connection: 
$$I_N = \frac{S_{AN}}{U_N}$$

Three-phase connection: 
$$I_N = \frac{S_{AN}}{U_N \cdot \sqrt{3}}$$

$I_N$ : Phase current at the power connection in A  
 $S_{AN}$ : Power connection output in VA  
 $U_N$ : Voltage between the phases of the power supply lines in V

Fig. 11-5: Calculating the phase current at the power connection

## Selecting fuse protector Q1 and line contactor K1

**Fuse protector Q1** The fuse protector must be rated 1.5 times higher than the actual current at the power connection  $I_N$ .

Fuse protection can be implemented using:

- an automatic circuit breaker (power circuit breaker) or
- a power circuit breaker or
- safety fuses.

**Line contactor K1** Select the line contactor according to the phase current at the power connection and the rated line voltage.

The rated current of the line contactor must be 1.5 times higher than the actual phase current at the power connection.

For a rated line voltage of 3 x 400 V, 50 Hz, the line contactors listed in the selection table are recommended depending on the phase current  $I_N$ .

**Selection table** The types specified in the selection table are from the Siemens company and serve as examples. Similar products from other manufacturers can also be used.

Phase current  $I_N$ in A	Line cross section (1)  $mm^2$	Recommended fuse protection						Recommended line contactor (for $U_N = 3 \times 400 \text{ V}, 50 \text{ Hz}$ )			
		Automatic circuit breaker (tripping characteristic C)		Power circuit breaker			Safety fuse (class gl)		Siemens type	Nominal operating current	N (3)
		Current in A	N (3)	Siemens type	Setting value in A	N (3)	Current in A	N (3)			
up to 8.7	1,0	10	5	3VU1300 - .ML00	10	12	10	4	3TF40	12	7
up to 11	1,5	16	7	3VU1300 - .MM00	16	19	16	6	3TF41	16	10
up to 15	2,5	20	9	3VU1300 - .MP00	20	24	20	9	3TF42	22	13
up to 21	4,0	32	15	3VU1300 - .MP00	25	30	32	14	3TF43	32	19

(1) Values apply to PVC insulated multi-wire cables in protective pipes and installation ducts with an ambient temperature of 45 °C (compliant to EN 60204-1/1992)

(2) The current was fixed based on operating mode AC 3 for a line voltage of AC 400 V, 50 Hz.

(3) N = maximum number of connectable drives taking the starting current into consideration. If more drives are connected than indicated, a fuse protector or line contactor with a higher current rating must be selected.

Fig. 11-6: Selection table for fuse protector Q1 and line contactor K1

### 11.3 Control circuit to the power connection

The control circuit recommended by INDRAMAT indicates the function principle.

The choice of the control and its efficiency depends on the range of functions and the efficiency of the entire plant or machine. Therefore, it is the manufacturer's responsibility to make this choice.

**Stand-by signal contact**

The stand-by message is output over a relay contact (make contact). If the stand-by contact closes, the drive is then ready for input power. It is thus used as a condition for switching in the line contactor (see Fig. 11-7).

**Note:** The contactor coil can cause excess voltages when switched off. The excess voltage can lead to premature failure of the stand-by contact. To attenuate the excess voltage, use an overvoltage limiter with diode combination.

The use of varistors as a suppressor circuit is not permitted. Varistors decay and increase their blocking-state currents. This can result in premature failure if the connected components and devices.

**Switching states**

The stand-by contact opens when:

- there is no control voltage for the DKC,
- if there are errors in the drive.

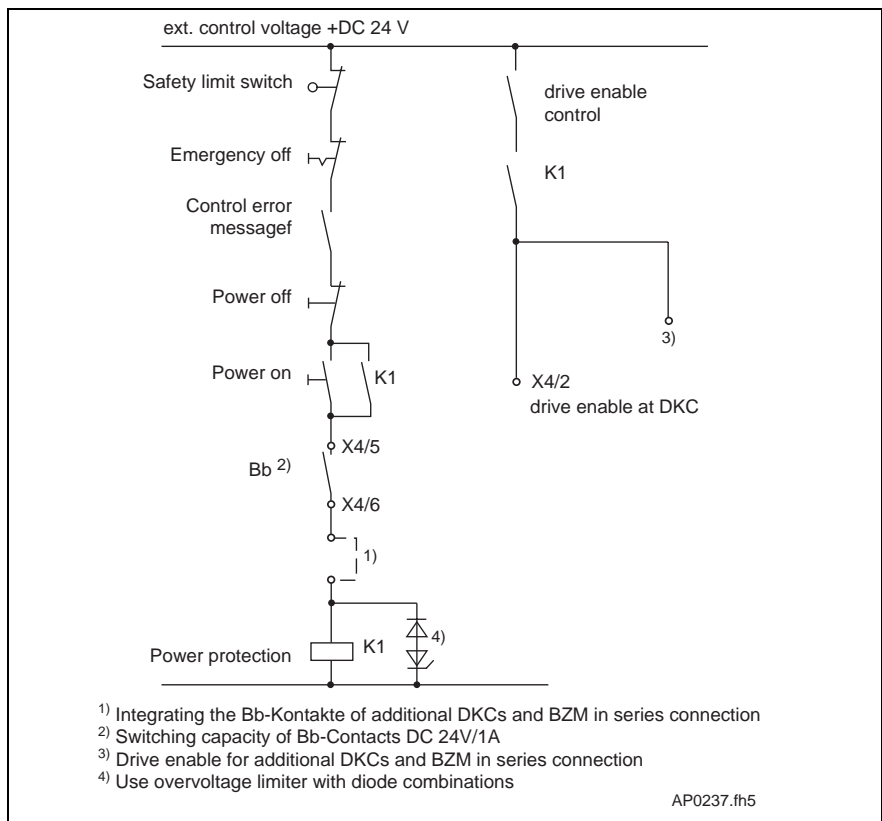

Fig. 11-7: Principal control switch to the DKC



## 11.4 Protection against indirect contact

As a result of the high capacitive leakage currents via the cable insulation, it is not possible to install a GFCB device in the power input line (compliant to DIN VDE 0160, section 6.5).

Thus, protection against indirect contact must be achieved by other means.

The drive system components have a protective grounded housing. This makes protection against indirect contact possible by grounding.

## Notes

## 12 Preparing for Startup

### Required equipment

The following equipment is necessary when starting operation of an ECODRIVE drive system:

- measuring devices
- a personal computer (PC)
- connecting cables (PC-DKC)
- setpoint generator

#### Measuring devices

The following measuring devices are required so that torque, current and speed can be measured as analog signals at the analog outputs:

- a multimeter for measuring voltage (suffices for series startups) and
- an oscilloscope or recorder (only needed for recording the signal sequences during startup operation for prototypes).

#### Personal computer (PC)

The PC is needed for programming, parameterization and diagnostics during startup operation and service procedures.

Hardware requirements:

- IBM compatibility
- 80386-SX microprocessor (80486 recommended)
- at least 4 MB RAM memory (8 MB recommended)
- harddisk with at least 2.5 MB of free storage space
- 3.5" floppy disk drive with a capacity of 1.44 MB
- one free serial RS-232 interface in the PC (COM 1 or COM 2)
- an EGA monitor or monitor with higher resolution
- a mouse or compatible pointing device

Software requirements:

- The operating system DOS 5.0 or higher
- Windows 3.1 or higher
- DriveTop startup program (floppy disk is included with ECODRIVE)

#### Connecting cables (PC-DKC)

To connect a PC with a 9-pin D-subminiature connector, use cable type IKS101.

To connect a PC with a 25-pin D-subminiature connector, use cable type IKS102.

Pin assignment of the cable Fig. 4-19.

**Setpoint generator**

To position the drive, a setpoint value must be input via the proper interface (positioning, analog or stepper interface).

For **test purposes** a speed setpoint must be input via the analog interface using a setpoint generator.

To do so, the EOCDRIVE must be switched to the main operating mode "Speed control with an analog setpoint value!" when operating via the positioning or stepper interface.

The following figure illustrates a circuit proposal for a setpoint generator.

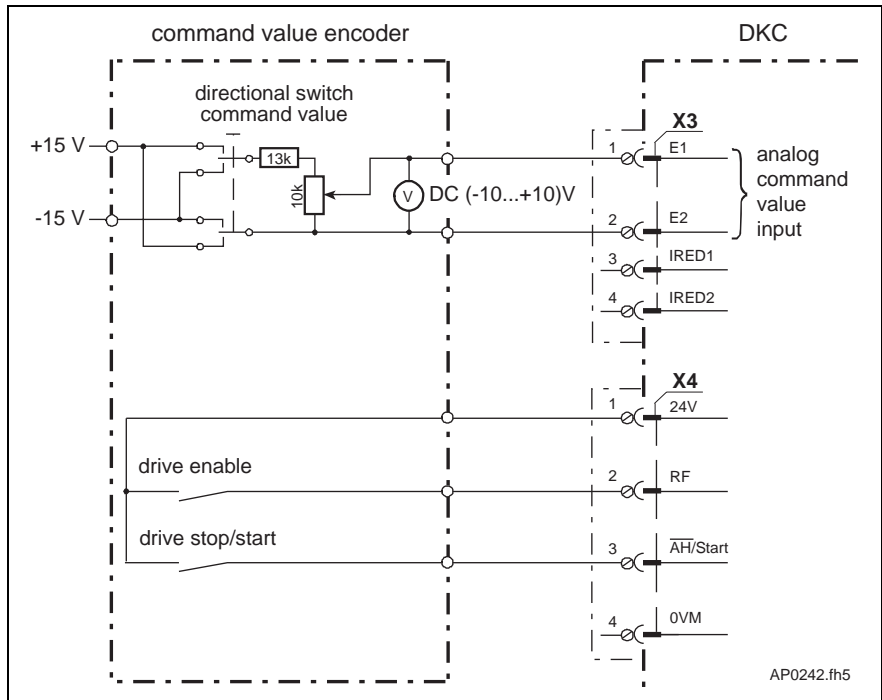

Fig. 12-1: Circuit proposal setpoint generator for connecting an analog interface

# 13 Condition of the drive components on delivery

## Packaging

- Packaging units** The packaging differs depending on the order.  
Each drive component is packaged individually, or several drive components are placed together in a single package.  
Accessories are fastened to the unit.
- Packaging materials** INDRAMAT will take packaging materials back free of charge. The customer is liable for return transport costs.
- Packaging labels** The bar-code label on the packaging identifies the components inside and the order number.

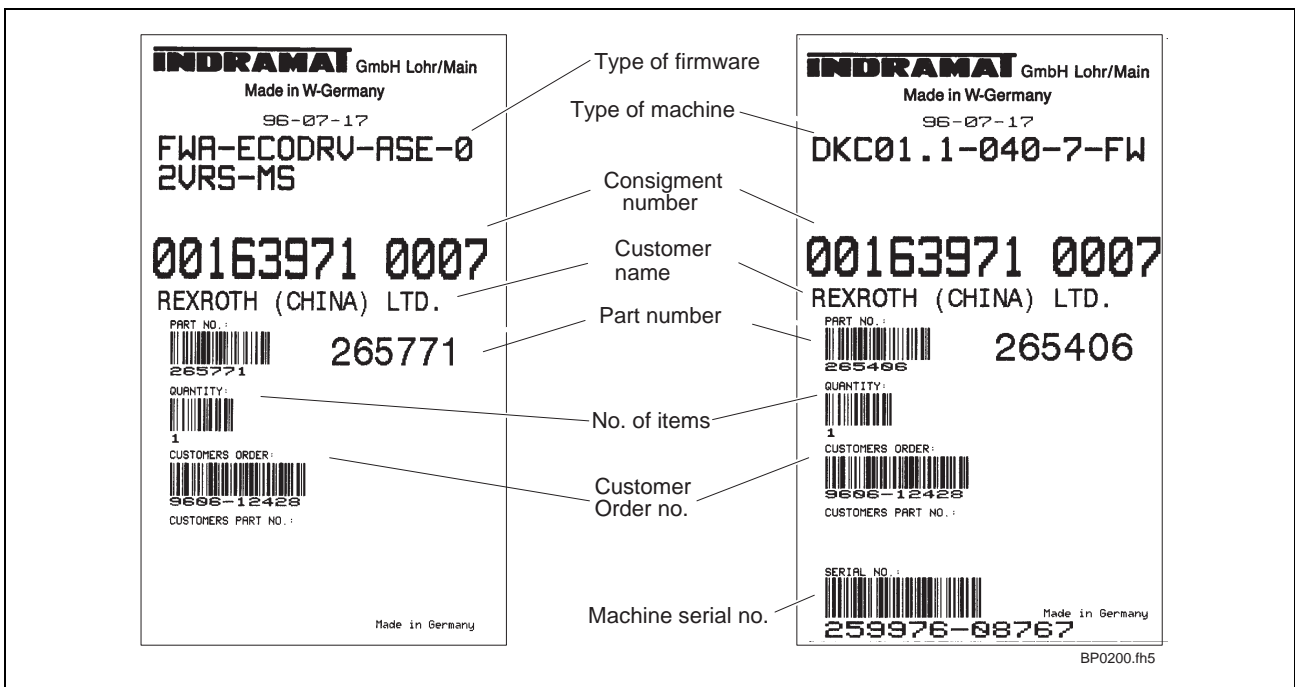

Fig. 13-1: Structure of the bar-code label on the packaging

## Accompanying documents

An envelope containing a delivery notice in duplicate is attached to one of delivered packages. These are the only shipping documents provided unless special arrangements were made when the order was placed.

Either the delivery notice or the freight papers will list the total number of packages or transport containers included in the shipment.

## Identification of the components

Each drive component is identified by a type designation.

There is a rating plate on all pieces of equipment, including the motor.

A label (cable tag) is wrapped around the ready-made cable. The type designation and the cable length is indicated on the tag. (The actual cable designation -- without connector-- can be found imprinted on the cable sheath).

The accessories packed in bags are identified either by a printed label on the bags or by an additional enclosed slip.

## Notes

# 14 Index

## A

Accompanying documents	13-1
Actual position value, incremental	4-28
Actual value position, absolute	4-30
ANALOG interface	4-12, 4-26
Analog setpoint value	4-26
Ansteuerung einkanalig	4-25

## C

Continuous regenerative power	5-1, 5-2, 5-3, 5-4
Control switch	11-4

## D

DC bus connection	4-31
DC-bus capacity	6-1
Diagnostics outputs	4-27
Differential signals	4-24
Dimensional data and installation dimensions	6-3

## F

Fuse protector Q1	11-2, 11-3
Fuse protector Q2	7-1

## G

Grounded power supply lines	9-1
-----------------------------	-----

## H

Homing	4-19
--------	------

## L

Line contactor	11-3
----------------	------

## M

Measuring devices	12-1
-------------------	------

## P

Packaging	13-1
Packaging labels	13-1
Peak regenerative power	5-1
Positioning signals	4-22
POSITIONING-interface	4-11
Power connection	11-1
Power dissipation	10-1

## R

Ready signal contact	11-4
Regenerative energy	5-1
Risk of condensation	10-2
Rotary energy	6-1
RS-232 interface	4-15
RS-485 interface	4-16

## S

serial bus	4-16
Setpoint generator	12-2
Single-phase line filter connection	8-4
Status reports	4-21
Stepper interface	4-23
stepping interface	4-14
Storable energy	6-1
Supply terminals	4-9

## T

Three-phase line filter connection	8-4
Tipp-Betrieb	4-20
Torque reduction	4-27
Transformers	9-1
Travel range limit	4-20

## U

Ungrounded power supply lines	9-1
-------------------------------	-----

## Notes



# Directory of customer service locations

## Germany

<b>Sales Region Central</b> INDRAMAT GmbH D-97816 Lohr am Main Bgm.-Dr.-Nebel-Str. 2 Telephone: 09352/40-0 Telefax: 09352/40-4885	<b>Sales Region East</b> INDRAMAT GmbH D-09120 Chemnitz Beckerstraße 31 Telephone: 0371/3555-0 Telefax: 0371/3555-230	<b>Sales Region West</b> INDRAMAT GmbH D-40849 Ratingen Hansastraße 25 Telephone: 02102/4318-0 Telefax: 02102/41315	<b>Sales Region North</b> INDRAMAT GmbH D-22085 Hamburg Fährhausstraße 11 Telephone: 040/227126-16 Telefax: 040/227126-15
<b>Sales Region South</b> INDRAMAT GmbH D-80339 München Ridlerstraße 75 Telephone: 089/540138-30 Telefax: 089/540138-10	<b>Sales Region Southwest</b> INDRAMAT GmbH D-71229 Leonberg Böblinger Straße 25 Telephone: 07152/972-6 Telefax: 07152/972-727		<b>INDRAMAT Service Hotline</b> INDRAMAT GmbH Telephone: D-0172/660 040 6 -oder- Telephone: D-0171/333 882 6

Customer service locations in Germany

## Europe

<b>Austria</b> G.L.Rexroth Ges.m.b.H. Geschäftsbereich INDRAMAT A-1140 Wien Hägelingasse 3 Telephone: 1/9852540-400 Telefax: 1/9852540-93	<b>Austria</b> G.L.Rexroth Ges.m.b.H. Geschäftsbereich INDRAMAT A-4061 Pasching Randlstraße 14 Telephone: 07229/64401-36 Telefax: 07229/64401-80	<b>Belgium</b> Mannesmann Rexroth N.V.-S.A. Geschäftsbereich INDRAMAT B-1740 Ternat Industrielaan 8 Telephone: 02/5823180 Telefax: 02/5824310	<b>Denmark</b> BEC Elektronik AS DK-8900 Randers Zinkvej 6 Telephone: 086/447866 Telefax: 086/447160
<b>England</b> Mannesmann Rexroth Ltd. INDRAMAT Division Cirencester, Glos GL7 1YG 4 Esland Place, Love Lane Telephone: 01285/658671 Telefax: 01285/654991	<b>Finnland</b> Rexroth Mecman OY SF-01720 Vantaa Riihimiehentie 3 Telephone: 0/848511 Telefax: 0/846387	<b>France</b> Rexroth - Sigma S.A. Division INDRAMAT F-92632 Gennevilliers Cedex Parc des Barbanniers 4, Place du Village Telephone: 1/41475430 Telefax: 1/47946941	<b>France</b> Rexroth - Sigma S.A. Division INDRAMAT F-69634 Venissieux - Cx 91, Bd 1 Joliot Curie Telephone: 78785256 Telefax: 78785231
<b>France</b> Rexroth - Sigma S.A. Division INDRAMAT F-31100 Toulouse 270, Avenue de Iardenne Telephone: 61499519 Telefax: 61310041	<b>Italy</b> Rexroth S.p.A. Divisione INDRAMAT I-20063 Cernusco S/N.MI Via G. Di Vittoria, 1 Telephone: 02/92365-270 Telefax: 02/92108069	<b>Italy</b> Rexroth S.p.A. Divisione INDRAMAT Via Borgomanero, 11 I-10145 Torino Telephone: 011/7712230 Telefax: 011/7710190	<b>Netherlands</b> Hydraudyne Hydrauliek B.V. Kruisbroeksestraat 1a P.O. Box 32 NL-5280 AA Boxtel Telephone: 04116/51951 Telefax: 04116/51483
<b>Spain</b> Rexroth S.A. Centro Industrial Santiago Obradors s/n E-08130 Santa Perpetua de Mogoda (Barcelona) Telephone: 03/718 68 51 Telex: 591 81 Telefax: 03/718 98 62	<b>Spain</b> Goimendi S.A. División Indramat Jolastokieta (Herrera) Apartado 11 37 San Sebastian, 20017 Telephone: 043/40 01 63 Telex: 361 72 Telefax: 043/39 93 95	<b>Sweden</b> AB Rexroth Mecman INDRAMAT Division Varuvägen 7 S-125 81 Stockholm Telephone: 08/727 92 00 Telefax: 08/64 73 277	<b>Switzerland</b> Rexroth SA Département INDRAMAT Chemin de l'Ecole 6 CH-1036 Sullens Telephone: 021/731 43 77 Telefax: 021/731 46 78
<b>Switzerland</b> Rexroth AG Geschäftsbereich INDRAMAT Gewerbestraße 3 CH-8500 Frauenfeld Telephone: 052/720 21 00 Telefax: 052/720 21 11	<b>Russia</b> Tschudnenko E.B. Arsenia 22 153000 Ivanovo Rußland Telephone: 093/22 39 633		

Other European customer service locations

## Other international locations

<p><b>Argentina</b></p> <p>Mannesmann Rexroth S.A.I.C. Division INDRAMAT Acassusso 48 41/7 1605 Munro (Buenos Aires) Argentina</p> <p>Telephone: 01/756 01 40 01/756 02 40 Telex: 262 66 rexro ar Telefax: 01/756 01 36</p>	<p><b>Argentina</b></p> <p>Nakase Asesoramiento Tecnico Diaz Velez 2929 1636 Olivos (Provincia de Buenos Aires) Argentina Argentina</p> <p>Telephone 01/790 52 30</p>	<p><b>Australia</b></p> <p>Australian Industrial Machinery Services Pty. Ltd. Unit 3/45 Horne ST Campbellfield VIC 2061 Australia</p> <p>Telephone: 03/93 59 0228 Telefax: 03/93 59 02886</p>	<p><b>Brazil</b></p> <p>Mannesmann Rexroth Automação Ltda. Divisão INDRAMAT Rua Georg Rexroth, 609 Vila Padre Anchieta BR-09.951-250 Diadema-SP Caixa Postal 377 BR-09.901-970 Diadema-SP</p> <p>Telephone: 011/745 90 65 011/745 90 70 Telefax: 011/745 90 50</p>
<p><b>Canada</b></p> <p>Basic Technologies Corporation Burlington Division 3426 Mainway Drive Burlington, Ontario Canada L7M 1A8</p> <p>Telephone: 905/335-55 11 Telefax: 905/335-41 84</p>	<p><b>China</b></p> <p>Rexroth (China) Ltd. Shanghai Office Room 206 Shanghai Intern. Trade Centre 2200 Yanan Xi Lu Shanghai 200335 P.R. China</p> <p>Telephone: 021/627 55 333 Telefax: 021/627 55 666</p>	<p><b>China</b></p> <p>Rexroth (China) Ltd. Shanghai Parts &amp; Service Centre 199 Wu Cao Road, Hua Cao Minhang District Shanghai 201 103 P.R. China</p> <p>Telephone: 021/622 00 058 Telefax: 021/622 00 068</p>	<p><b>China</b></p> <p>Rexroth (China) Ltd. 1430 China World Trade Centre 1, Jianguomenwai Avenue Beijing 100004 P.R. China</p> <p>Telephone: 010/50 50 380 Telefax: 010/50 50 379</p>
<p><b>China</b></p> <p>Rexroth (China) Ltd. A-5F., 123 Lian Shan Street Sha He Kou District Dalian 116 023 P.R. China</p> <p>Telephone: 0411/46 78 930 Telefax: 0411/46 78 932</p>	<p><b>Honkong</b></p> <p>Rexroth (China) Ltd. 19 Cheung Shun Street 1st Floor, Cheung Sha Wan, Kowloon, Honkong</p> <p>Telephone: 741 13 51-54 und 741 14 30 Telex: 3346 17 GL REX HX Telefax: 786 40 19 786 07 33</p>	<p><b>India</b></p> <p>Mannesmann Rexroth (India) Ltd. INDRAMAT Division Plot. 96, Phase III Peenya Industrial Area Bangalore - 560058</p> <p>Telephone: 80/839 21 01 80/839 73 74 Telex: 845 5028 RexB Telefax: 80/839 43 45</p>	<p><b>Japan</b></p> <p>Rexroth Co., Ltd. INDRAMAT Division I.R. Building Nakamachidai 4-26-44 Tsuzuki-ku, Yokohama 226 Japan</p> <p>Telephone: 045/942-72 10 Telefax: 045/942-03 41</p>
<p><b>Korea</b></p> <p>Rexroth-Seki Co Ltd. 1500-12 Da-Dae-Dong Saha-Gu, Pusan, 604-050</p> <p>Telephone: 051/264 90 01 Telefax: 051/264 90 10</p>	<p><b>Korea</b></p> <p>Seo Chang Corporation Ltd. Room 903, Jeail Building 44-35 Yoido-Dong Youngdeungpo-Ku Seoul, Korea</p> <p>Telephone: 02/780-82 07 -9 Telefax: 02/784-54 08</p>	<p><b>Mexico</b></p> <p>Motorización y Diseño de Controles, S.A. de C.V. Av. Dr. Gustavo Baz No. 288 Col. Parque Industrial la loma Apartado Postal No. 318 54060 Tlalnepantla Estado de Mexico</p> <p>Telephone: 5/397 86 44 Telefax: 5/398 98 88</p>	
<p><b>USA</b></p> <p>Rexroth Corporation INDRAMAT Division 5150 Prairie Stone Parkway Hoffman Estates, Illinois 60192</p> <p>Telephone: 847/645-36 00 Telefax: 857/645-62 01</p>	<p><b>USA</b></p> <p>Rexroth Corporation INDRAMAT Division 2110 Austin Avenue Rochester Hills, Michigan 48309</p> <p>Telephone: 810/853-82 90 Telefax: 810/853-82 90</p>		

Other international customer service locations

## Notes

