

Connections

Terminal Diagram

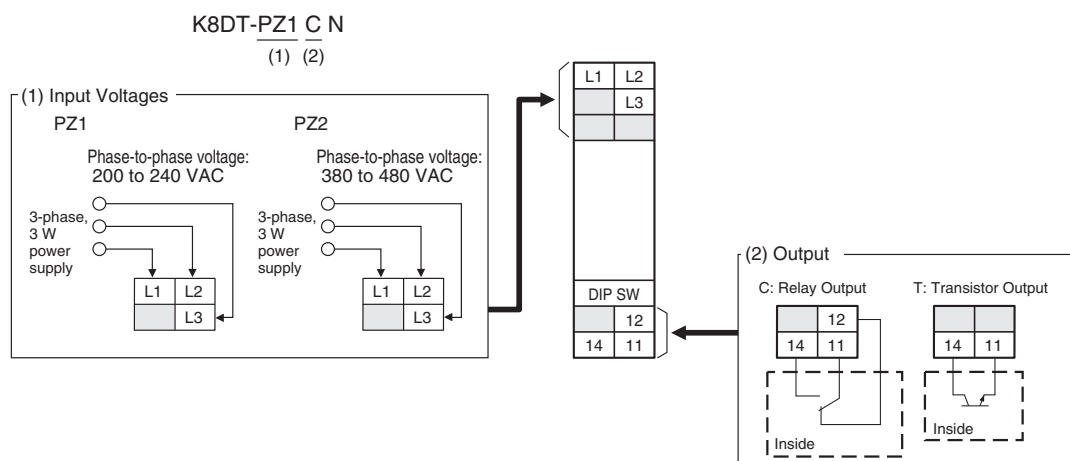

Note: Do not connect anything to terminals that are shaded in gray.

Wiring Example

Relay Output

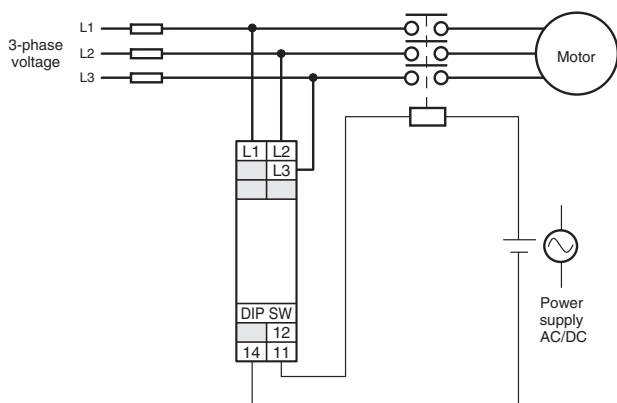

Transistor Output

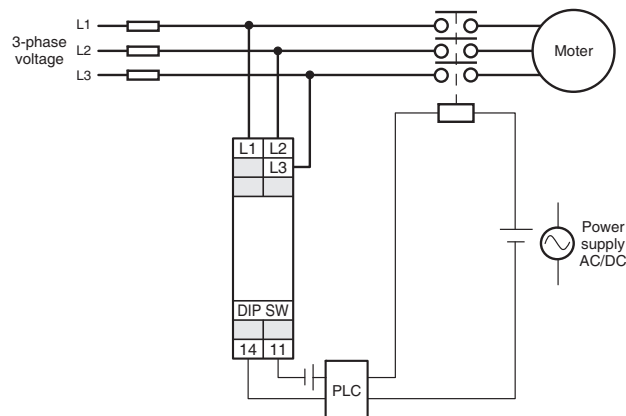

Note: Use copper wires with a rating of 75°C or an equivalent rating.

Timing Charts

Overvoltage, Undervoltage, Phase Sequence, and Phase Loss Operation Diagram

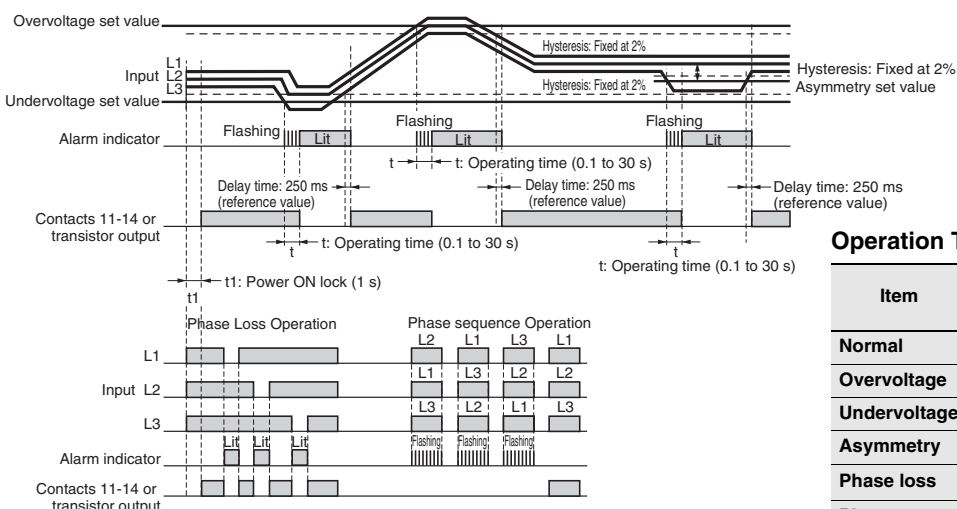

- Note:**
1. The K8DT-PZ□ output contacts are normally operative.
 2. The power ON lock prevents unnecessary alarms from being generated during the unstable period when the power is first turned ON. There is no contact output during timer operation.
 3. Phase loss is detected by a drop in the L1, L2, or L3 voltage. A phase loss is detected when any of the phase-to-phase voltages goes below 60% of the rated input.
 4. L1 and L2 are also used for the power supply. If the voltage becomes very low, the Relay will not operate.
 5. Phase loss (on power supply side and load side) is not detected in the motor load during operation.

Operation Table

Item	Indicators		Output operation
	OUT_LED	ALM_LED	
Normal	ON	OFF	ON
Overvoltage	OFF	ON	OFF
Undervoltage	OFF	ON	OFF
Asymmetry	OFF	ON	OFF
Phase loss	OFF	ON *1	OFF
Phase sequence	OFF	Flashing *2	OFF

- *1. L1 and L2 are also used for the power supply. If the voltage becomes very low, the indicator will turn OFF.
 *2. The indicator will flash once per second after an incorrect phase is detected and once per 0.5 second during the detection time.

K8DT-PZ

Nomenclature

Front

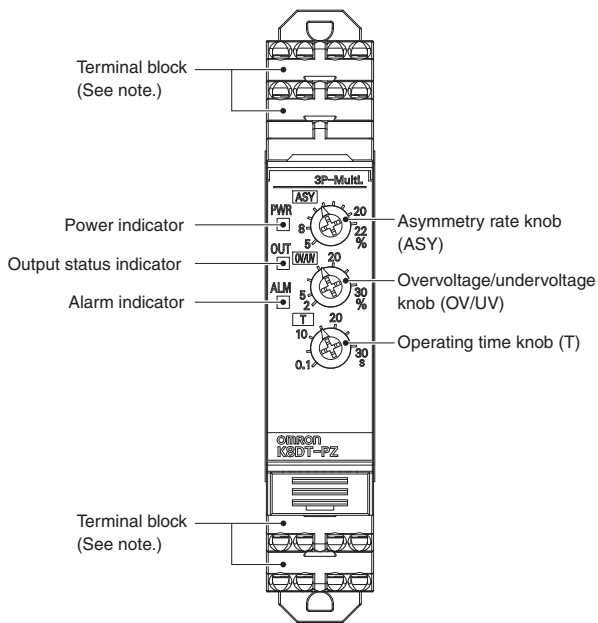

Note: Use solid wires, stranded wires, or ferrules to connect to the terminals.
To maintain the withstand voltage after connecting the terminals, insert 8 mm of exposed conductor into the terminal.

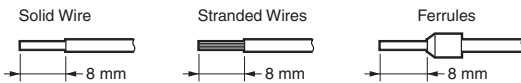

Indicators

Item	Meaning
Power indicator (PWR: Green)	Lit when power is being supplied. *
Output status indicator (Output: Yellow)	Lights for output (lit for normal operation)
Alarm indicator	<ul style="list-style-type: none"> Lights for overvoltage/undervoltage error. When the voltage exceeds the set value, the indicator flashes for the operating time to indicate the error status. Lights for asymmetry error. Lights for phase loss. Flashes for phase sequence error.

* This indicator uses the input across L1 and L2 as the internal power supply. It will not light unless there is an input across L1 and L2.

Setting Knobs

Item	Description
Asymmetry rate knob (ASY)	Used to set from 5% to 22%.
Overvoltage/undervoltage knob (OV/UV)	Used to set from 2% to 30% of the rated input.
Operating time knob (T)	Used to set the operating time to 0.1 to 30 s.

Operation Methods

Connections

Input

Wire the input to the L1, L2, and L3 terminals (3-phase, 3-wire).
Make sure the phase sequence is wired correctly. The Unit will not operate normally if the phase sequence is incorrect.

Outputs

For a relay output, the SPDT contacts are output on terminals 11, 12, and 14. For a transistor output, the output is on terminals 11 and 14.

The internal circuit of the transistor output is NPN, but application is possible for either a sinking or sourcing output.

In the case of sinking output applications

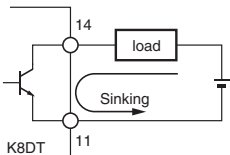

In the case of sourcing output applications

