

Product Overview

The PowerFlex® 520-Series AC drive delivers an innovative design that is remarkably versatile and can accommodate systems ranging from standalone machines to simple system integration. The PowerFlex 523 drive provides general purpose control for applications ranging up to 30 HP and 22 kW. The PowerFlex 525 drive provides maximum flexibility and performance ranging up to 30 HP and 22 kW.

By combining various motor control options, communications, energy savings, and standard safety features in a cost-effective drive, the PowerFlex 520-Series drive is suitable for a wide array of applications.

Maximize your system performance and productivity by taking advantage of the following key features offered in a PowerFlex 520-Series drive.

PowerFlex 520-Series AC Drives Feature

Modular Design

- Detachable control module and power module allow **simultaneous configuration and installation**.
- Each drive has a **standard control module** used across the entire power range.
- **MainsFree configuration** allows you to simply connect your control module to a PC with a standard USB cable and quickly upload, download, and flash the drive with new settings.
- **Support for accessory cards** without affecting footprint. (PowerFlex 523 drives support one, PowerFlex 525 drives support two)

Packaging and Mounting

- Installation can be quick and easy using the **DIN rail mounting** feature on A, B, and C frame drives. Panel mounting is also available, providing added flexibility.
- **Zero Stacking** is allowed for ambient temperatures up to 45 °C, saving valuable panel space.
- **Integral filtering** is available on all 200V and 400V ratings, providing a cost-effective means of meeting EN61800-3 Category C2 and C3 EMC requirements. External filters provide compliance to EN61800-3 Category C1, C2, and C3 EMC requirements for all PowerFlex 520-Series ratings.
- An optional **IP 30, NEMA/UL Type 1 conduit box** is easily adapted to the standard IP 20 (NEMA Type Open) product, providing increased environmental ratings.

Optimized Performance

- **Removable MOV** to ground provides trouble-free operation when used on ungrounded distribution systems.
- A **relay precharge** limits inrush current.
- **Integral brake transistor**, available on all ratings, provides dynamic braking capability with simple low cost brake resistors.
- A jumper to switch between **24V DC sink or source control** for control wiring flexibility.
- **Dual Overload Rating** available for drives above 15 HP/11 kW. Normal duty: 110% overload for 60 seconds or 150% for 3 seconds. Heavy duty: 150% overload for 60 seconds or 180% overload (200% programmable) for 3 seconds provides robust overload protection.
- **Adjustable PWM frequency up to 16 kHz** ensures quiet operation.

PowerFlex 520-Series AC Drive Advanced Features

Control Performance

- **Variety of motor control options, including:**
 - Volts per Hertz (V/Hz)
 - Sensorless Vector Control (SVC)
 - Closed loop velocity vector control (PowerFlex 525 drives only)
 - Permanent Magnet motor control (PowerFlex 525 drives only)
- **Variety of Positioning Control, including:**
 - PointStop™ stops motor load in a consistent position without encoder feedback
 - Closed loop feedback with an optional encoder card (PowerFlex 525 drives only)
 - Point-to-point positioning mode (PowerFlex 525 drives only)
- **Integral PID** functionality enhances application flexibility (PowerFlex 523 drives have one PID loop, PowerFlex 525 drives have two PID loops)

I/O Wiring

PowerFlex 523

- **One Analog Input** (unipolar voltage or current) independently isolated from the rest of the drive I/O.
- **Five Digital Inputs** (four programmable) provide application versatility.
- **One Analog Output^(a)** which is jumper selectable between either 0...10V or 0...20 mA. This scalable, 10-bit output is suitable for metering or as a speed reference to another device.
- **One Relay Output** (form C) can be used to indicate various drive, motor or logic conditions.

PowerFlex 525

- **Two Analog Inputs** (one unipolar and one bipolar) are independently isolated from the rest of the drive I/O. These inputs can be toggled via a digital input.
- **Seven Digital Inputs** (six programmable) provide application versatility.
- **One Analog Output** which is jumper selectable between either 0...10V or 0...20 mA. This scalable, 10-bit output is suitable for metering or as a speed reference to another drive.
- **Two Opto Outputs and two Relay Outputs** (one form A and one form B) can be used to indicate various drive, motor or logic conditions.

PowerFlex 523 Series B Control I/O Wiring Block Diagram

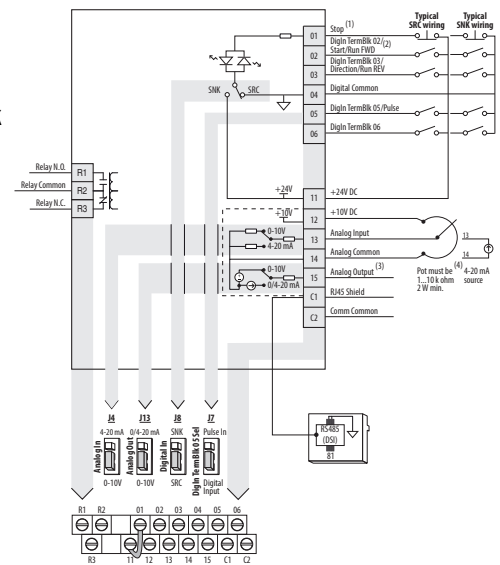

PowerFlex 525 Control I/O Wiring Block Diagram

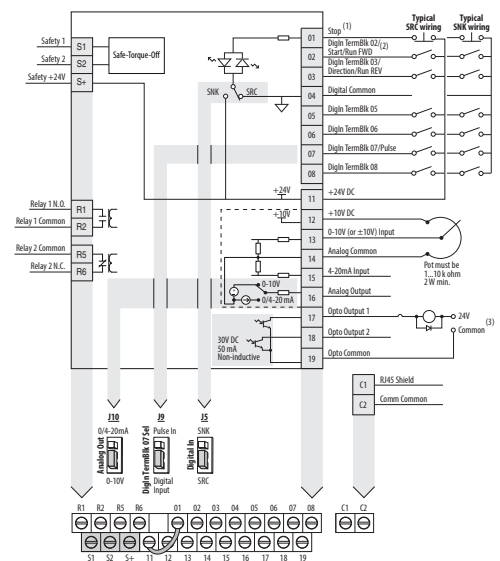

(a) Analog output (terminal 15) is only available on PowerFlex 523 series B drive and requires firmware 3.001 and later to configure the analog output parameters.