

Control Modes

- Indexer, Point-to-Point, PVT
- Camming, Gearing, Position, Velocity, Torque

Command Interface

- CANopen
- ASCII and discrete I/O
- Stepper commands
- ±10V position/velocity/torque command
- PWM velocity/torque command
- Master encoder (Gearing/Camming)

Communications

- CANopen
- RS232

Feedback

- Digital Quad A/B encoder
- Secondary encoder / emulated encoder out
- Analog sin/cos encoder
- Resolver
- Digital Halls

I/O - Digital

- 12 inputs, 4 outputs

Accessories

- External regen resistors
- External edge filter

Dimensions: mm [in]

- 7.5 x 5.5 x 2.5 [191 x 140 x 64]

DESCRIPTION

Xenus combines CANopen networking with 100% digital control of brushless or brush motors in an off-line powered package that can operate from single or three-phase mains with continuous power output to 4 kW.

Xenus is offered in two versions based on the type of feedback. Standard models supports digital quadrature or analog sin/cos encoders. Resolver feedback is available in "-R" models which convert the resolver angle into quadrature encoder signals for using Xenus with external controllers.

Xenus operates as a Motion Control Device under the DSP-402 protocol of the CANopen DS-301 V4.01 (EN 50325-4) application layer. DSP-402 modes supported include: Profile Position, Profile Velocity, Profile Torque, Interpolated Position (PVT), and Homing.

Drive commissioning is fast and simple using CME 2 software operating under Windows® communicating with Xenus via CAN or an RS-232 link. CAN address selection is by a 16-position rotary switch on the front panel. If there are more than fifteen devices on a CAN bus, the additional address bits needed can come from programmable inputs, or can be set in flash memory. Profile Position Mode does a complete motion index on command with S-curve acceleration & deceleration, top speed, and distance programmable. In PVT mode, the controller sends out a sequence of points each of which is an increment of a larger, more complex move than a single index or profile. The drive then uses cubic polynomial interpolation to "connect the dots" such that the motor reaches each point (Position) at the specified velocity (Velocity) at the prescribed time (Time).



Model	Vac	Ic	Ip
XSL-230-18	100 - 240	6	18
XSL-230-36	100 - 240	12	36
XSL-230-40	100 - 240	20	40

Resolver version: append -R

Homing mode is configurable to work with a variety of limit, index, and home switches such that the drive moves the motor into a position that has an absolute reference to some part of the machine. Eleven logic inputs are programmable as limit or home switches, stepper/encoder pulse inputs, reset, digital torque or velocity reference, or motor-temperature. A twelfth input is dedicated to the drive Enable function. Three programmable logic outputs are for reporting a drive fault or other status indications. A fourth optically-isolated output can drive a motor brake from the external +24 Vdc power supply or can be programmed as a logic output.

In addition to CANopen motion commands, Xenus can operate as a stand-alone drive. Current and velocity modes accept ±10 Vdc analog, digital 50% PWM or PWM/polarity inputs. In position mode inputs can be incremental position commands from step-motor controllers in Pulse/Direction or CW/CCW format, ±10 Vdc analog, or A/B quadrature commands from a master-encoder. Pulse to position ratio is programmable for electronic gearing. Power output of the drive varies with the input power which can range from 100 to 240 Vac, and from 47 to 63 Hz. Either single or three phase mains can be used giving Xenus the ability to work in the widest possible range of industrial settings. Signal and control circuits are isolated from the high-voltage power supply and inverter stage that connect to the mains. A +24 Vdc input powers control circuits for keep-alive operation permitting the drive power stage to be completely powered down without losing position information or communications with the control system.

GENERAL SPECIFICATIONS (ALL VERSIONS)

Test conditions: Wye connected load: 2 mH line-line. Ambient temperature = 25 °C. Power input = 230 Vac, 60 Hz, 1 Ø

MODEL	XSL-230-18	XSL-230-36	XSL-230-40	
	XSL-230-18-R	XSL-230-36-R	XSL-230-40-R	
OUTPUT CURRENT				
Peak Current	18 (12.7)	36 (25.5)	40 (28.3)	Adc (Arms, sinusoidal)
Peak time	1	1	1	s
Continuous current (Note 1)	6 (4.24)	12 (8.5)	20 (14.1)	Adc (Arms, sinusoidal)
INPUT POWER				
Mains voltage, phase, frequency	100~240			Vac, ±10%, 1 Ø or 3 Ø, 47~63 Hz
Mains current	20			Arms
+24 Vdc Control power	+20 to +32 Vdc, 500 mA max			Required for operation
DIGITAL CONTROL				
Digital Control Loops	Current, velocity, position. 100% digital loop control			
Sampling rate (time)	Current loop: 15 kHz (67 µs), Velocity & position loops: 3 kHz (333 µs)			
Bus voltage compensation	Changes in bus or mains voltage do not affect bandwidth			
Minimum load inductance	200 µH line-line			
COMMAND INPUTS (NOTE: DIGITAL INPUT FUNCTIONS ARE PROGRAMMABLE)				
<i>As CAN node</i>				
CANopen bus	Position & Velocity Mode commands		Homing, Profile, and Interpolated profile modes	
<i>Stand-alone mode</i>				
Analog torque, velocity, position reference	±10 Vdc, 12 bit resolution		Dedicated differential analog input	
Input impedance	74.8 kΩ		Between Ref(+), Ref(-)	
Digital position reference	Pulse/Direction, CW/CCW		Stepper commands (2 MHz maximum rate)	
	Quad A/B Encoder		2 M line/sec, 8 Mcount/sec (after quadrature)	
Digital torque & velocity reference	PWM, Polarity		PWM = 0% - 100%, Polarity = 1/0	
	PWM 50%		PWM = 50% ±50%, no polarity signal required	
	PWM frequency range		1 kHz minimum, 100 kHz maximum	
	PWM minimum pulse width		220 ns	
DIGITAL INPUTS				
Number	12			
All inputs	74HC14 Schmitt trigger operating from 5.0 Vdc with RC filter on input, 10 kΩ to +5 Vdc or ground (selectable)			
Logic levels	Vin-LO < 1.35 Vdc, Vin-HI > 3.65 Vdc			
Pull-up, pull-down control	Inputs are divided into four groups with selectable connection of input pull-up/down resistor to +5 Vdc or ground for each group: [IN1,2,3], [IN4,5], [IN6,7,8], [IN9,10,11,12]			
Enable [IN1]	1 dedicated input with 330 µs RC filter for drive enable. Active level programmable, +24 Vdc max			
GP [IN2,3,4,5,11,12]	6 General Purpose inputs with 330 µs RC filter, programmable functions, and active level select, +24 Vdc max			
HS [IN6,7,8,9,10]	5 High-Speed Inputs inputs with 100 ns RC filter, programmable functions, and active level select, +12 Vdc max			
DIGITAL OUTPUTS (NOTE 2)				
Number	4			
[OUT1], [OUT2], [OUT3]	Current-sinking MOSFET with 1 kΩ pullup to +5 Vdc through diode			
Current rating	1 Adc max, +40 Vdc max. Functions programmable			
	External flyback diode required if driving inductive loads			
Brake [OUT4]	Opto-isolated, current-sinking with flyback diode to +24 Vdc, 1 Adc			
QUADRATURE ENCODER OUTPUTS				
Maximum frequency	18 M-counts, post-quadrature (4.5 M-lines/sec)			
Encoder feedback models				
Operation	Motor encoder signals are buffered and appear on J7			
Signals	A, /A, B, /B, X, /X			
Driver	26LS31 differential line driver			
Resolver feedback models				
Operation	Quadrature encoder emulation with programmable resolution to 4096 lines (65,536 count/rev)			
Signals	A, /A, B, /B			
Driver	26LS31 differential line driver			
RS-232 PORT				
Signals	RxD, TxD, Gnd in 6-position, 4-contact RJ-11 style modular connector			
Mode	Full-duplex, serial communication port for drive setup and control, 9,600 to 115,200 baud			
Protocol	Binary and ASCII formats			
CAN PORTS				
Signals	CANH, CANL, Gnd in 8-position RJ-45 style modular connector, wired as per CAN Cia DR-303-1, V1.1			
Format	CAN V2.0b physical layer for high-speed connections compliant			
Data	CANopen Device Profile DSP-402			
Address selection	16 position rotary switch on front panel with 3 additional address bits available as digital inputs or programmable to flash memory (7-bit addressing, 127 nodes per CAN network)			
STATUS INDICATORS				
Drive Status	Bicolor LED, drive status indicated by color, and blinking or non-blinking condition			
CAN Status	Bicolor LED, status of CAN bus indicated by color and blink codes to CAN Indicator Specification 303-3			
REGENERATION				
Operation	Internal solid-state switch drives external regen resistor (see Ordering Guide for types)			
Cut-In Voltage	+HV > 390 Vdc	Regen output is on, (optional external) regen resistor is dissipating energy		
Drop-Out Voltage	+HV < 380 Vdc	Regen output is off, (optional external) regen resistor not dissipating energy		
Tolerance	±2 Vdc	For either Cut-In or Drop-Out voltage		
Hysteresis	10 ±0.5 Vdc	Differential between Cut-In & Drop-Out voltage		
NOTES:				
1. Heatsinking and/or forced-air cooling is required for continuous output power rating				
2. Brake[OUT4] is programmable as motor brake, or as general purpose digital output				

GENERAL SPECIFICATIONS (ALL VERSIONS, CONTINUED)

PROTECTIONS

HV Overvoltage	+HV > 400 Vdc	Drive PWM outputs turn off until +HV is less than overvoltage
HV Undervoltage	+HV < 60 Vdc	Drive PWM outputs turn off until +HV is greater than undervoltage
Drive over temperature	IGBT > 80 °C ±3 °C	Drive PWM outputs turn off until IGBT temperature is below threshold
Short circuits	Output to output, output to ground, internal PWM bridge faults	
I ² T Current limiting	Programmable: continuous current, peak current, peak time	
Motor over temperature	Drive shuts down when motor over-temperature switch changes to high-resistance state, or opens	
Feedback power loss	Fault occurs if feedback +5 Vdc output is < 85% of nominal value	

MECHANICAL & ENVIRONMENTAL

Size	7.55 in (191,8 mm) X 5.57 in (141,5 mm) X 2.57 in (65,3 mm)	
Weight	3.0 lb (1.36 kg) for drive without heatsink 1.9 lb (0.86 kg) for XSL-HS heatsink, 1.26 lb (0.57 kg) for XSL-HL heatsink	
Ambient temperature	0 to +45 °C operating, -40 to +85 °C storage	
Humidity	0% to 95%, non-condensing	
Contaminants	Pollution degree 2	
Environment	IEC68-2: 1990	
Cooling	Heat sink and/or forced air cooling required for continuous power output	

SPECIFICATIONS FOR ENCODER FEEDBACK VERSIONS

DIGITAL ENCODER

Type	Quadrature, differential line driver outputs
Signals	A, /A, B, /B, (X, /X, index signals optional)
Frequency	5 MHz line frequency, 20 MHz quadrature count frequency

ANALOG ENCODER

Type	Sin/cos, differential line driver outputs, 0.5 V _{peak-peak} (1.0 V _{peak-peak} differential) centered about 2.5 Vdc typical. Common-mode voltage 0.25 to 3.75 Vdc
Signals	Sin(+), sin(-), cos(+), cos(-)
Frequency	230 kHz maximum line (cycle) frequency
Interpolation	10 bits/cycle (1024 counts/cycle)

DIGITAL HALLS

Type	Digital, single-ended, 120° electrical phase difference
Signals	U, V, W
Frequency	Consult factory for speeds >10,000 RPM

ENCODER POWER SUPPLY

Power Supply	+5 Vdc @ 400 mA to power encoders & Halls
Protection	Current-limited to 750 mA @ 1 Vdc if overloaded Encoder power developed from +24 Vdc so position information is not lost when AC mains power is removed

MOTOR CONNECTIONS

Phase U, V, W	PWM outputs to 3-phase ungrounded Wye or delta connected brushless motors
Hall U, V, W	Hall signals
Digital Encoder	A, /A, B, /B, (X, /X)
Analog Encoder	Sin(+), sin(-), cos(+), cos(-)
Hall & encoder power	+5 Vdc @ 400 mA maximum
Motemp [IN5]	Motor overtemperature sensor input. Active level programmable. 4.99 kΩ to +5 Vdc or ground Disables drive when motor over-temperature condition occurs Same input circuit as GP digital inputs
Signal ground	Return for encoder, Halls, and temperature sensor
Brake [OUT4]	Current-sinking motor brake driver
+24 Vdc	From drive +24 Vdc power supply to power motor brake
Frame ground	For motor cable shield

SPECIFICATIONS FOR RESOLVER FEEDBACK VERSIONS

RESOLVER

Type	Brushless, single-speed, 1:1 to 2:1 programmable transformation ratio
Resolution	14 bits (equivalent to a 4096 line quadrature encoder)
Reference frequency	7.5 kHz
Reference voltage	2.8 Vrms, auto-adjustable by the drive to maximize feedback
Reference maximum current	100 mA
Maximum RPM	10,000

ENCODER EMULATION

Resolution	Programmable to 65,536 counts/rev (4096 line encoder equivalent)
Buffered encoder outputs	26C31 differential line driver

MOTOR CONNECTIONS

Phase U, V, W	PWM outputs to 3-phase ungrounded Wye or delta connected brushless motors
Resolver	R1, R2, S1, S2, S3, S4
Motemp [IN5]	Motor overtemperature sensor input. Active level programmable. 4.99 kΩ to +5 Vdc or ground Disables drive when motor over-temperature condition occurs Same input circuit as GP digital inputs
Signal ground	Return for temperature sensor
Brake [OUT4]	Current-sinking motor brake driver
+24 Vdc	From drive +24 Vdc power supply to power motor brake
Frame ground	For motor cable shield

AGENCY STANDARDS CONFORMANCE

EN 55011 : 1998	CISPR 11 (1997) Edition 2/Amendment 2: Limits and Methods of Measurement of Radio Disturbance Characteristics of Industrial, Scientific, and Medical (ISM) Radio Frequency Equipment
EN 61000-6-1 : 2001	Electromagnetic Compatibility Generic Immunity Requirements
Following the provisions of EC Directive 89/336/EEC:	
EN 60204-1 : 1997	Safety of Machinery - Electrical Equipment of Machines
Following the provisions of EC Directive 2006/42/EC:	
UL 508C 3 rd Ed.: 2002	UL Standard for Safety for Power Conversion Equipment

DIMENSIONS

Inches (mm)

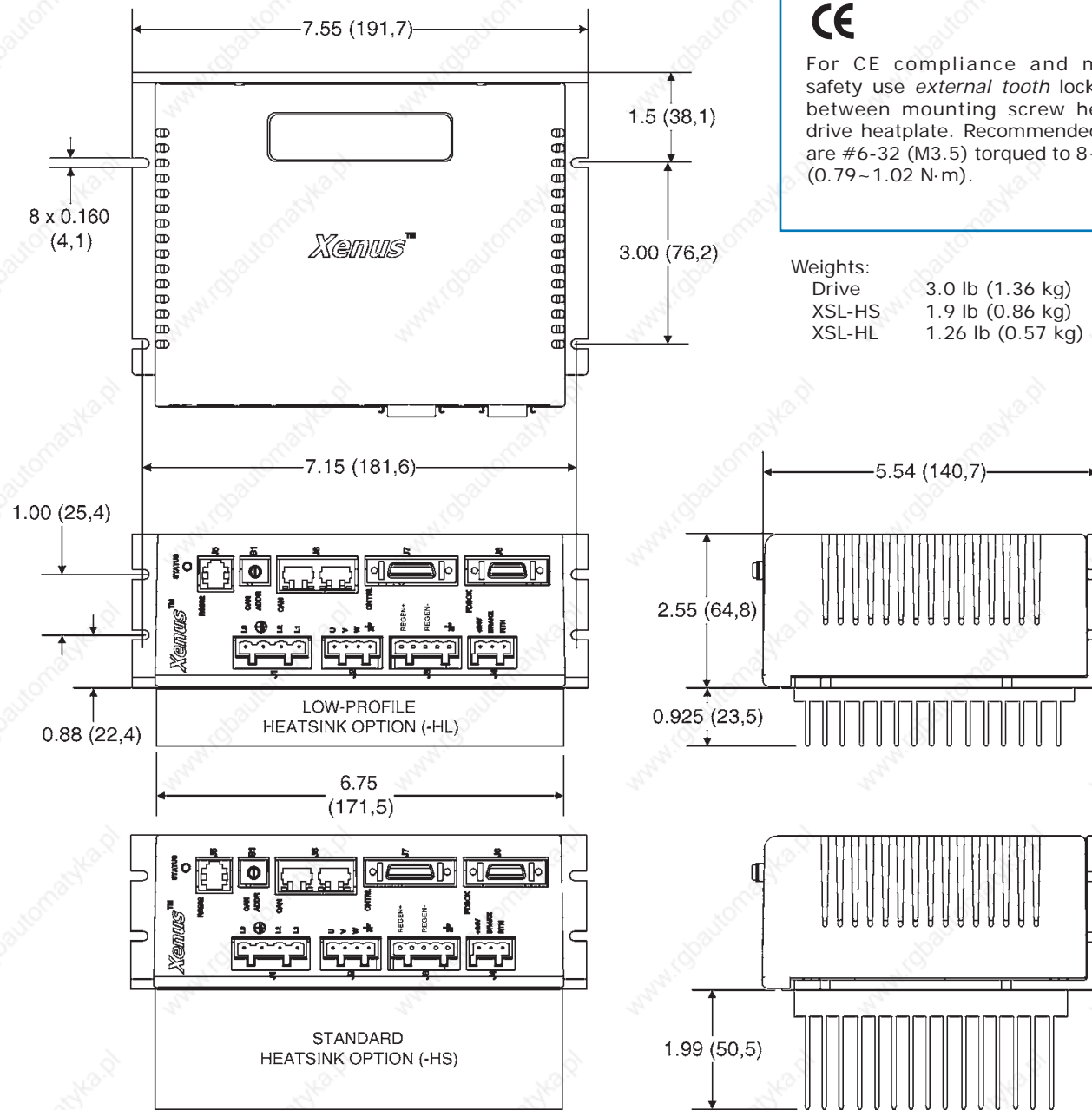

For CE compliance and machine safety use *external tooth* lockwashers between mounting screw head and drive heatplate. Recommended screws are #6-32 (M3.5) torqued to 8~10 lb.in (0.79~1.02 N.m).

Weights:

Drive	3.0 lb (1.36 kg)
XSL-HS	1.9 lb (0.86 kg)
XSL-HL	1.26 lb (0.57 kg)

COMMUNICATIONS

CME 2 SOFTWARE

Drive setup is fast and easy using CME 2 software. All of the operations needed to configure the drive are accessible through this powerful and intuitive program. Auto-phasing of brushless motor Hall sensors and phase wires eliminates "wire and try". Connections are made once and CME 2 does the rest thereafter. Encoder wire swapping to establish the direction of positive motion is eliminated.

Motor data can be saved as .ccm files. Drive data is saved as .ccx files that contain all drive settings plus motor data. This eases system management as files can be cross-referenced to drives. Once a drive configuration has been completed systems can be replicated easily with the same setup and performance.

RS-232 COMMUNICATION

Xenus is configured via a three-wire, full-duplex RS-232 port that operates from 9,600 to 115,200 Baud. CME 2 software communicates with the drive over this link for commissioning and adjustments.

When operating as a stand-alone drive that takes command inputs from an external controller, CME 2 is used for configuration. When operated as a CAN node, CME 2 can be used for programming before and after installation in a CAN network. Xenus can also be controlled via CME 2 while it is in place as a CAN node. During this process, drive operation as a CAN node is suspended. When adjustments are complete, CME 2 relinquishes control of the drive and returns it to the CAN node state.

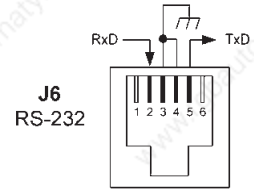

CANOPEN NETWORKING

Based on the CAN V2.0b physical layer, a robust, two-wire communication bus originally designed for automotive use where low-cost and noise-immunity are essential, CANopen adds support for motion-control devices and command synchronization. The result is a highly effective combination of data-rate and low cost for multi-axis motion control systems. Device synchronization enables multiple axes to coordinate moves as if they were driven from a single control card.

CANOPEN COMMUNICATION

Xenus uses the CAN physical layer signals CANH, CANL, and GND for connection, and CANopen protocol for communication. Before installing the drive in a CAN system, it must be assigned a CAN address. A maximum of 127 CAN nodes are allowed on a single CAN bus. The rotary switch on the front panel controls the four lower bits of the seven-bit CAN address. When the number of nodes on a bus is less than sixteen, the CAN address can be set using only the switch. For installations with sixteen or more CAN nodes on a network CME 2 can be used to configure Xenus to use the rotary switch, or combinations of digital inputs and programmed offset in flash memory to configure the drive with a higher CAN node address.

CAN STATUS LED

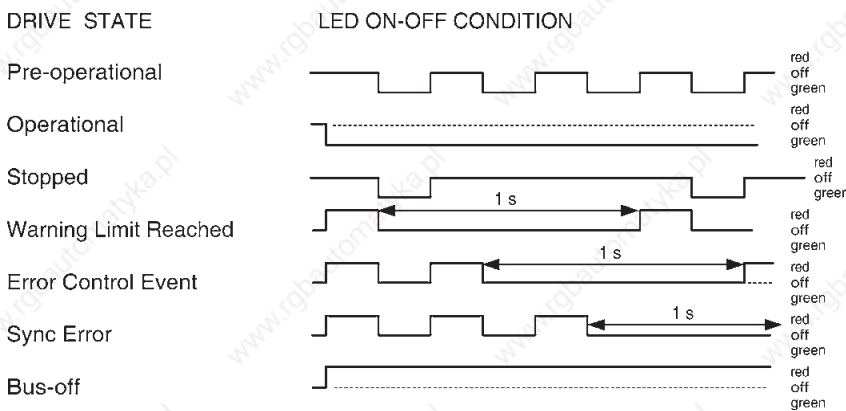

Note: Red & green led on-times do not overlap.
LED color may be red, green, off, or flashing of either color.

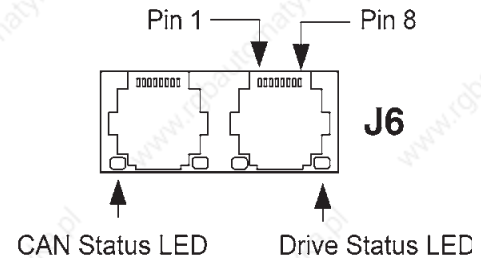

Drive Fault conditions:

- Over or under-voltage
- Motor over-temperature
- Encoder +5 Vdc fault
- Short-circuits from output to output
- Short-circuits from output to ground
- Internal short circuits
- Drive over-temperature

Faults are programmable to be either transient or latching

DRIVE STATUS LED

A single bi-color LED gives the state of the drive by changing color, and either blinking or remaining solid.

The possible color and blink combinations are:

- Green/Solid: Drive OK and enabled. Will run in response to reference inputs or CANopen commands.
- Green/Slow-Blinking: Drive OK but NOT-enabled. Will run when enabled.
- Green/Fast-Blinking: Positive or Negative limit switch active. Drive will only move in direction not inhibited by limit switch.
- Red/Solid: Transient fault condition. Drive will resume operation when fault is removed.
- Red/Blinking: Latching fault. Operation will not resume until drive is Reset

COMMAND INPUTS

CANOPEN

As an intelligent node on a distributed-control network the drive can operate in current, velocity, or position mode with all control loops closed in the drive. Using Copley's CMO (Copley Motion Objects) or CML (Copley Motion Libraries) software, multiple drives can be controlled from high-level languages such as Visual Basic or C++. CANopen operation supports Profile Position, Profile Velocity, Profile Torque and Homing modes. In addition to these operating modes, all of the drive configuration parameters are available in CAN mode offering great flexibility of operation and control.

ASCII

RS-232 communications provides a simple hardware control capability for Xenus in applications that don't require the power or flexibility provided by CANopen operation. And, while RS-232 does not support multi-drop connections like RS-485, multiple Xenus (or other Copley CANopen drives) can be controlled from a single COM port. This is done by setting the CAN address of the drive that connects to the COM port to "0", and then using CAN cables to connect other Copley drives in daisy-chain fashion. The "0" drive now acts as a CAN bus master communicating with the other drives over the CAN. The effect is to have the ability to communicate with multiple drives from a single RS-232 port.

INDEXING

As an indexing drive, Xenus can be controlled from digital I/O lines or via CANopen or ASCII, communications. Up to 32 sequences can be addressed with an additional priority sequence that can be launched from a single input or data-command. A sequence can consist of moves, homing, gain changes, time delays, wait-for-input, set-output, or camming, with each containing combinations of these. Additional flexibility is provided by the ability to replace program constants (i.e. move distance) with register addresses. A register is a storage location in drive RAM memory and can be changed via RS-232, or CANopen communications. Using this technique a PLC can launch an index with

digital I/O, and change the parameters over an ASCII link to find-tune the machine operation without changing the basic PLC program. As an indexing drive, Xenus control and motor-driving in a stand-alone package.

CAMMING

In camming mode Xenus synchronizes its motion with the encoder of an external device using cam tables that are stored in flash memory. A cam-table consists of two columns of numbers the first of which contains master encoder position values, and the second of which contains slave positions. When the cam profile is initiated position feedback from the external master encoder is compared to entries in the master column. When the master encoder position equals a value in the master column, the position in the slave column is sent to the drive's position loop. In this way, non-linear motion profiles can be executed from an encoder that tracks the position of moving machinery. Initiation of a camming move can be done with the master-encoder's index signal or from a digital input. For testing or stand-alone operation the master encoder can be internal to Xenus where it's frequency is programmable. Up to 10 cam tables can be stored in Xenus and each can have its own master encoder, trigger source and offsets.

DIGITAL REFERENCE INPUTS

In stand-alone mode, digital reference inputs control drive current or velocity in the same fashion as the analog reference input, but do it using digital signals. Digital inputs [IN9] and [IN10] have high-speed input filters and can be programmed for signals in several formats. Current (torque, force) or velocity commands can be in one or two-wire format. In the one-wire format (50% PWM), a single input takes a square waveform that has a 50% duty cycle when the drive output should be zero. Thereafter, increasing the duty cycle toward 100% will command a maximum positive output, and decreasing the duty cycle toward 0% will produce a maximum negative output.

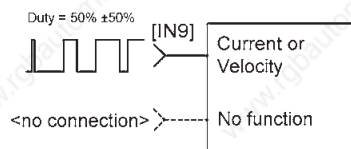

50% PWM Format

In two-wire format (PWM/Direction), one input takes a PWM waveform of fixed frequency and variable duty cycle, and the other input takes a DC level that controls the polarity of the output current. A 0% duty cycle will command zero current, and a 100% will produce a maximum. The direction of the force or torque produced will depend on the polarity of the DC signal on the direction input. In either mode, inputs are programmable to treat 0% or 100% inputs as faults as a safety measure should a cable break.

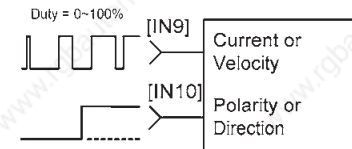

PWM/Direction Format

PWM U-V REFERENCE INPUTS

In most applications Xenus uses encoder and/or Hall feedback from the motor for commutation. This is the process by which motor currents are constantly adjusted so that they produce a magnetic field in the windings that is at ±90 degrees electrical with the magnetic field of the permanent-magnets so that torque or force is produced in proportion to the magnitude of the currents. For controllers that perform this function externally to the drive, the PWM U-V mode is provided. This provides control of the magnitude and polarity of the currents in the U & V phases of the motor, and sets the W phase current equal to the sum of the U-V currents times (-1).

ANALOG REFERENCE INPUT

A single ±10 Vdc differential input takes inputs from controllers that use PID or similar compensators, and output a current or velocity vs. reference input voltage is programmable.

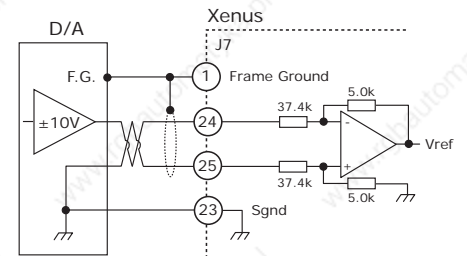

INPUT / OUTPUT

DIGITAL INPUTS

Xenus has twelve digital inputs, eleven of which have programmable functions. Input [IN1] is dedicated to the drive Enable function. This is done to prevent accidental programming of the input in such a way that the controller could not shut it down.

Two types of RC filters are used: GP (general purpose) and HS (high speed). Input functions such as Pulse/Dir, CW/CCW, Quad A/B are wired to inputs having the HS filters, and inputs with the GP filters are used for general purpose logic functions, limit switches, and the motor temperature sensor. Programmable functions of the digital inputs are:

- Positive Limit switch
- Negative Limit switch
- Home switch
- Drive Reset
- Pulse & Direction, or CW/CCW step motor position commands
- Quad A/B master encoder position commands
- CAN address bits
- Motor over-temperature
- Reference input attenuation select (zero or divide by eight)

In addition to the active level and function for each programmable input, the input resistors are programmable in four groups to either pull up to +5 Vdc, or down to ground. Grounded inputs with HI active levels interface to PLC's that have PNP outputs that source current from +24 Vdc sources. Inputs pulled up to +5 Vdc work with open-collector, or NPN drivers that sink current to ground.

DIGITAL INPUT CIRCUITS

24VDC MAX

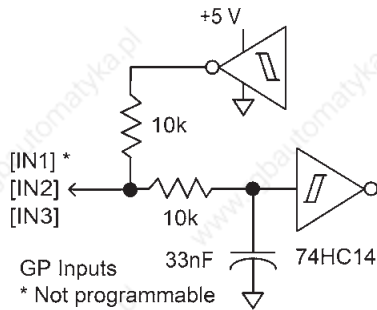

24VDC MAX

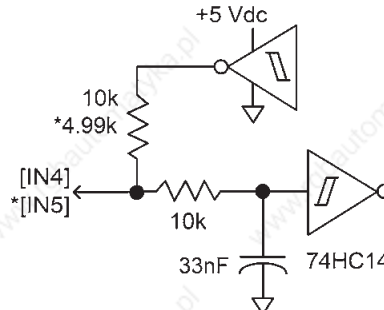

12VDC MAX

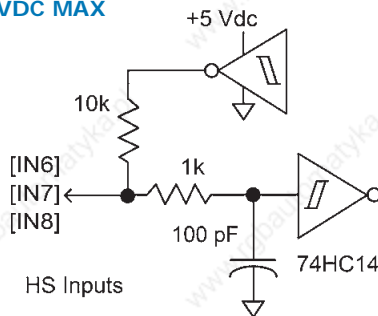

12VDC MAX (*24VDC)

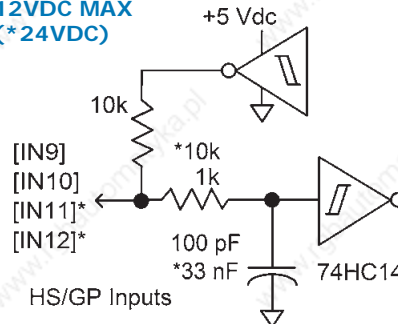

DIGITAL OUTPUTS

The digital outputs are open-drain MOSFETs with 1 kΩ pull-up resistors in series with a diode to +5 Vdc. They can sink up to 1 Adc from external loads operating from power supplies to +30 Vdc.

The output functions are programmable. The active state of the outputs is programmable to be on or off.

When driving inductive loads such as a relay, an external fly-back diode is required. The internal diode in the output is for driving PLC inputs that are opto-isolated and connected to +24 Vdc. The diode prevents conduction from +24 Vdc through the 1 kΩ resistor to +5 Vdc in the drive. This could turn the PLC input on, giving a false indication of the drive output state.

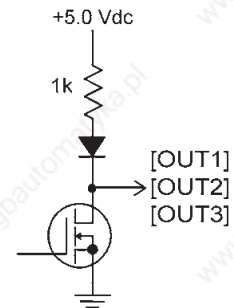

BRAKE OUTPUT [OUT4]

This output is an open-drain MOSFET with an internal flyback diode connected to the +24 Vdc input. It can sink up to 1A from a motor brake connected to the +24 Vdc supply. The operation of the brake is programmable with CME 2. It can also be programmed as a general-purpose digital output.

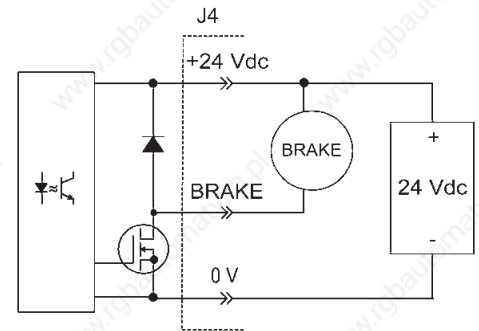

FEEDBACK : ENCODER VERSIONS

DIGITAL ENCODERS

The motor encoder interface is a differential line-receiver with R-C filtering on the inputs. The circuit is shown below. Encoders with differential outputs are required because they are less susceptible to noise that can degrade single-ended outputs. Encoder cables should use twisted-pairs for each signal pair: A & /A, B & /B, Index & /Index. An overall shield should be used, and for longer cables, shields for individual pairs may be necessary to guarantee signal integrity.

The encoder signals are made available to the controller via the signal connector J7, where they are re-transmitted by differential line-drivers. This eliminates split cables that would have to route the motor encoder signals to both drive and controller, as well as providing a good signal quality termination of the encoder signals at the drive.

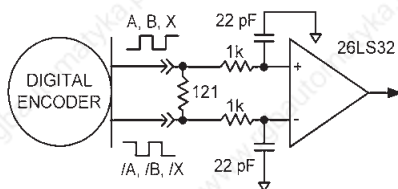

ANALOG ENCODERS

Xenus supports analog encoder signals for position feedback. The Sin and Cos inputs are differential with 121 Ω terminating resistors and accept 1.0 Vp-p signals in the A/B format used by encoders with analog outputs such as Heidenhain, Stegman, and Renishaw.

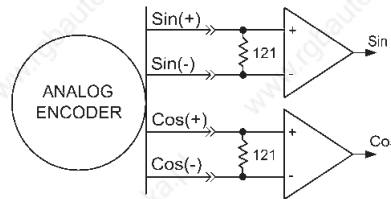

Sin/Cos Encoder Signals

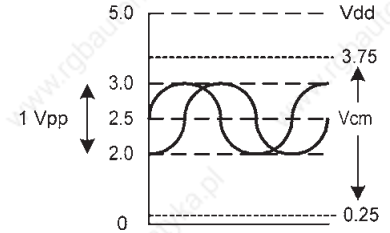

Vdd = Encoder supply voltage
Vcm = Common-Mode Voltage

DIGITAL HALL SIGNALS

Use of these signals is optional. Xenus is capable of auto-phasing using encoder signals and motor movement on power-up. Hall signals are single-ended signals that provide absolute feedback within one electrical cycle of the motor. There are three of them (U, V, & W) and they may be sourced by magnetic sensors in the motor, or by encoders that have Hall tracks as part of the encoder disc. They typically operate at much lower frequencies than the motor encoder signals, and in Xenus they are used for commutation-initialization after startup, and for checking the motor phasing after the drive has switched to sinusoidal commutation.

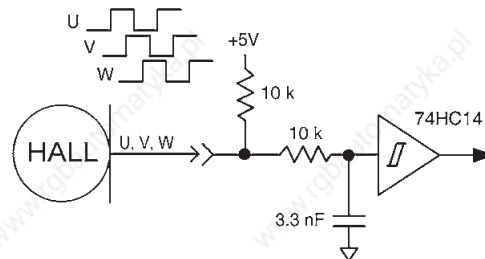

FEEDBACK : RESOLVER VERSIONS

RESOLVER

Connections to the resolver should be made with shielded cable that uses three twisted-pairs. Once connected, resolver set up, motor phasing, and other commissioning adjustments are made with CME 2 software. There are no hardware adjustments.

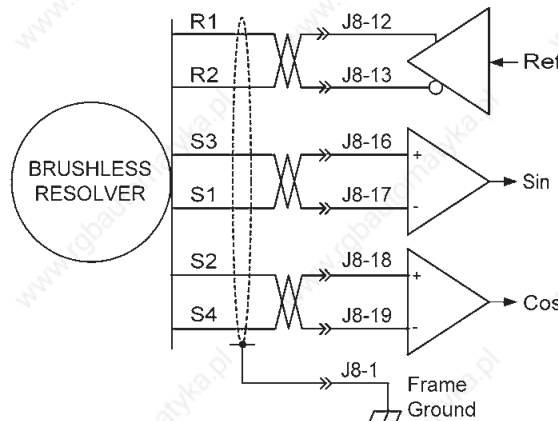

MULTI-MODE ENCODER PORT

This port consists of three differential input/output channels that take their functions from the drive Basic Setup. For dual-loop position-mode operation that employs a primary encoder on the motor, and a secondary encoder on the load, the port works as an input receiving the secondary encoder's quad A/B/X signals. For stand-alone operation with an external motion controller, the signals from the digital encoder on the motor are buffered and made available at the control signal connector for transmission to the controller. This eliminates split-wired motor cables with dual connectors that take the encoder signals to both drive and controller. When used with ServoTube motors, or other motors using analog encoders with sin/cos signal format, the drive interpolates the sin/cos signals to a resolution that is programmable. The incremental changes in position are then converted to digital quad A/B/X format for use by the external motion controller.

BUFFERED OUTPUTS FROM PRIMARY QUAD A/B/X ENCODER

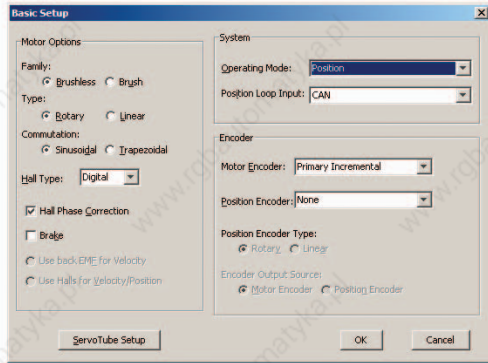

FUNCTIONAL DIAGRAM OF ONE CHANNEL

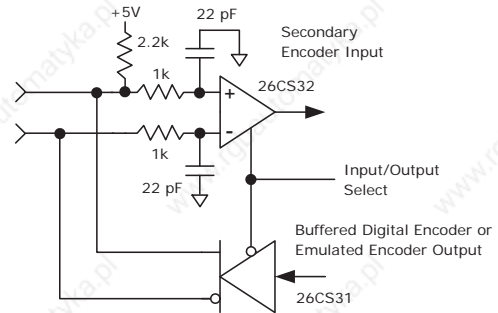

EMULATED QUAD A/B OUTPUTS FROM SERVOTUBE MOTORS

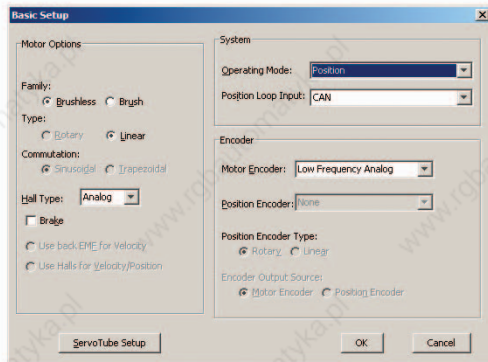

EMULATED QUAD A/B OUTPUTS FROM RESOLVER MOTORS

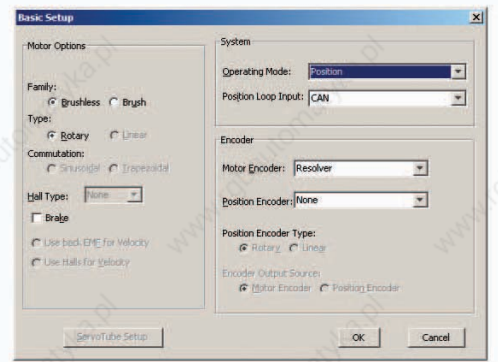

BUFFERED OUTPUTS FROM DIGITAL PRIMARY ENCODER OR EMULATED QUAD A/B OUTPUTS FROM ANALOG POSITION ENCODER

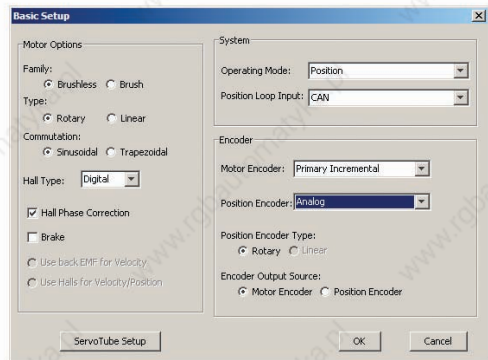

DIGITAL POSITION ENCODER INPUT FOR RESOLVER MOTORS

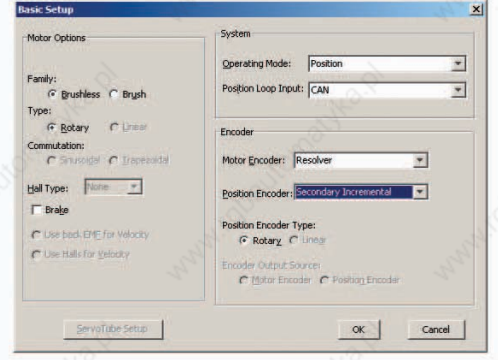

CE = Shielded cables required for CE compliance

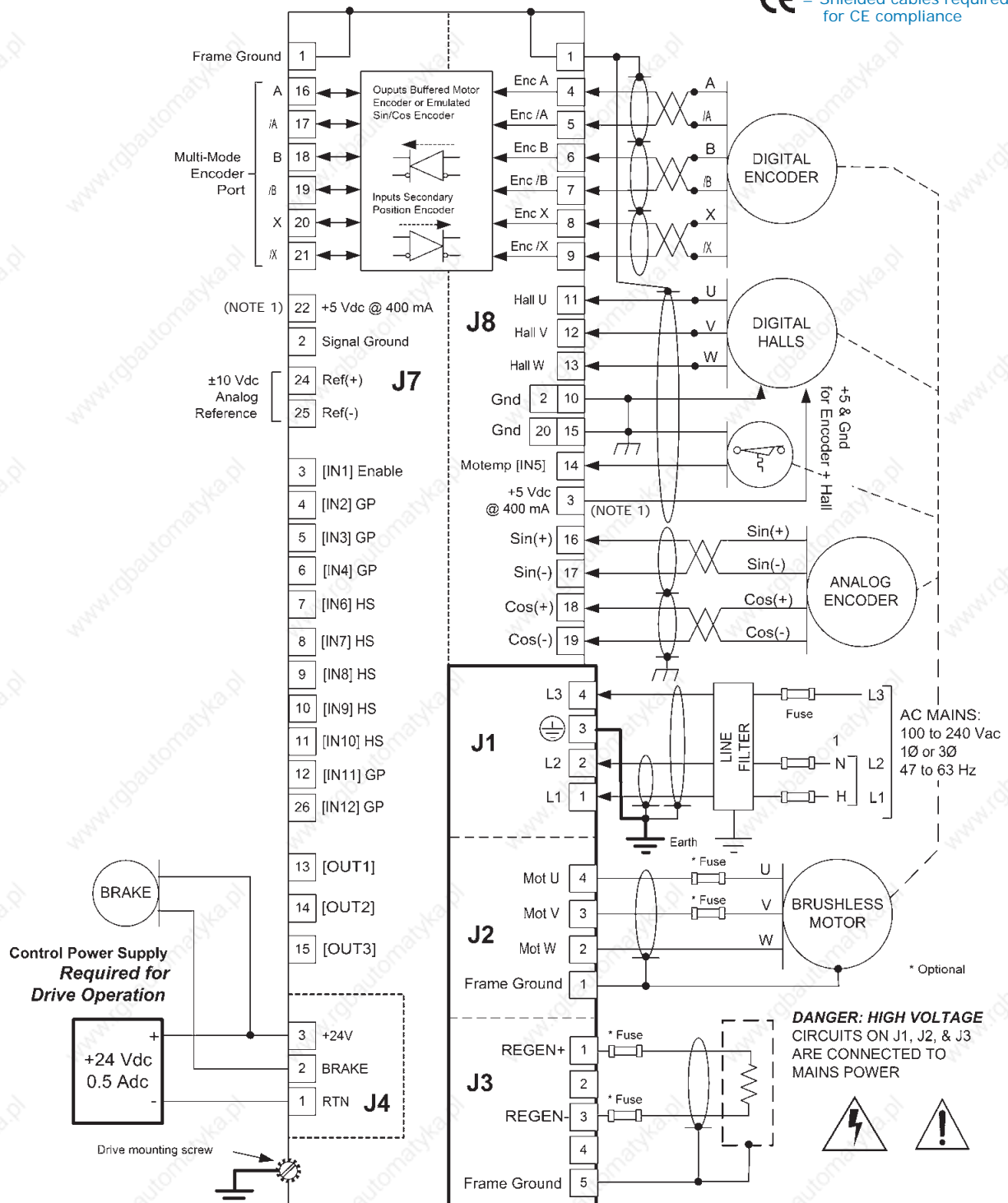

NOTES:

1. The total output current from the +5 Vdc supply to J7-22 and J8-3 cannot exceed 400 mA dc.

ACCESSORY CABLE CONNECTIONS

SIGNAL CABLE (XSL-CC-10)

Cable assembly: CCC p/n 59-00785-000
Molded connector mates with drive J8 and has flying-lead terminations.

CONNECTOR (FRONT VIEW)

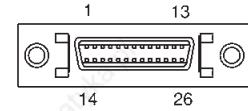

Signal	Pin	Color (Body/Stripe)	Pair	Color (Body/Stripe)	Pin	Signal
Frame Ground	1	Rev A & B: White/Tan Rev C: Brown	1a 8a	White/Violet	14	[OUT2]
Signal Ground	2	Rev A & B: Tan/White Rev C: Orange	1b 8b	Violet/White	15	[OUT3]
Enable [IN1]	3	White/Brown	2a 9a	White/Grey	16	Multi-Encoder A
GP Input [IN2]	4	Brown/White	2b 9b	Gray/White	17	Multi-Encoder /A
GP Input [IN3]	5	White/Pink	3a 10a	Tan/Brown	18	Multi-Encoder B
GP Input [IN4]	6	Pink/White	3b 10b	Brown/Tan	19	Multi-Encoder /B
HS Input [IN6]	7	White/Orange	4a 11a	Tan/Pink	20	Multi-Encoder X
HS Input [IN7]	8	Orange/White	4b 11b	Pink/Tan	21	Multi-Encoder /X
HS Input [IN8]	9	White/Yellow	5a 12a	Tan/Orange	22	+5 Vdc @ 400 mA
HS Input [IN9]	10	Yellow/White	5b 12b	Orange/Tan	23	Signal Ground
HS Input [IN10]	11	White/Green	6a 13a	Tan/Yellow	24	Analog Ref(+)
GP Input [IN11]	12	Green/White	6b 13b	Yellow/Tan	25	Analog Ref(-)
[OUT1]	13	White/Blue	7a 7b	Blue/White	26	[IN12] GP Input

FEEDBACK CABLE (XSL-FC-10)

Cable assembly: CCC p/n 59-00786-000
Molded connector mates with drive J8 and has flying-lead terminations.

CONNECTOR (FRONT VIEW)

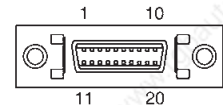

Signal	Pin	Color (Body/Stripe)	Pair	Color (Body/Stripe)	Pin	Signal
Frame Ground	1	Rev A & B: White/Tan RevC: Brown	1a 8a	Rev A & B: Tan/White Rev C: Orange	11	Digital Hall U
Signal Ground	2	White/Brown	1b 8b	White/Blue	12	Digital Hall V
+5 Vdc @ 400 mA	3	Brown/White	2a 9a	Blue/White	13	Digital Hall W
Encoder Input A	4	White/Pink	2b 9b	White/Violet	14	[IN5] Temp Sensor
Encoder Input /A	5	Pink/White	3a 10a	Violet/White	15	Signal Ground
Encoder Input B	6	White/Orange	3b 10b	White/Gray	16	Analog Sin(+)
Encoder Input /B	7	Orange/White	4a 11a	Gray/White	17	Analog Sin(-)
Encoder Input X	8	White/Yellow	4b 11b	Tan/Brown	18	Analog Cos(+)
Encoder Input /X	9	Yellow/White	5a 12a	Brown/Tan	19	Analog Cos(-)
Signal Ground	10	White/Green	5b 12b	Green/White	20	Signal Ground

Note: Cable shields connect to connector shells and not to conductors. The shells of drive J7 & J8 are connected to the earth ground terminal on power connector J1 and to the drive chassis. When the cables above are connected to the drive a continuous path from cable shield to earth is established for shielding and CE compliance.



WARNING: Hazardous voltages exist on connections to J1, J2, & J3 when power is applied, and for up to 30 seconds after power is removed.



J1 Mains Connections

J1 CABLE CONNECTOR:

Wago 721-204/026-045
* (51118287 or 721-204/026-045/RN01-0000)
Euro-style 7,5 mm pluggable female terminal block with preceding ground receptacle
Cable: AWG 12, 600 V recommended for XSL-230-36 and XSL-230-40 models, AWG 14, 600V for XSL-230-18
Shielded cable required for CE compliance

Signal	Pin
Mains Input L3	4
Protective Ground	3
Mains Input L2	2
Mains Input L1	1

J2 CABLE CONNECTOR:

Wago 721-104/026-047
* (51118008 or 721-104/026-047/RN01-0000)
Euro-style 5,0 mm pluggable female terminal block
Cable: AWG 12, 600 V recommended for XSL-230-36 and XSL-230-40 models, AWG 14, 600V for XSL-230-18
Shielded cable required for CE compliance

J2 Motor Outputs

Signal	Pin
Motor Phase U	4
Motor Phase V	3
Motor Phase W	2
Cable Shield	1

J3 CABLE CONNECTOR:

Wago 721-605/000-043
* (51111279 or 721-605/000-044/RN01-0000)
Euro-style 5,0 mm pluggable male terminal block
Cable: AWG 12, 600 V recommended for XSL-230-36 and XSL-230-40 models, AWG 14, 600V for XSL-230-18
Shielded cable required for CE compliance

J3 Regen Resistor

Signal	Pin
Regen Resistor	1
No Connection	2
Regen Resistor	3
No Connection	4
Cable Shield	5

WIRE INSERTION/EXTRACTION TOOL:

Used on J1, J2, J3 & J4
Wago 231-131

NOTE: AN EXTERNAL +24 VDC POWER SUPPLY IS REQUIRED FOR OPERATION

J4 CABLE CONNECTOR:

Wago 721-103/026-047
* (51117974 or 721-103/026-047/RN01-0000)
Euro-style 5,0 mm pluggable terminal block

J4 +24 VDC & Brake

Signal	Pin
+24 Vdc Control Power	3
Brake Output [OUT4]	2
0V (+24 Vdc Return)	1

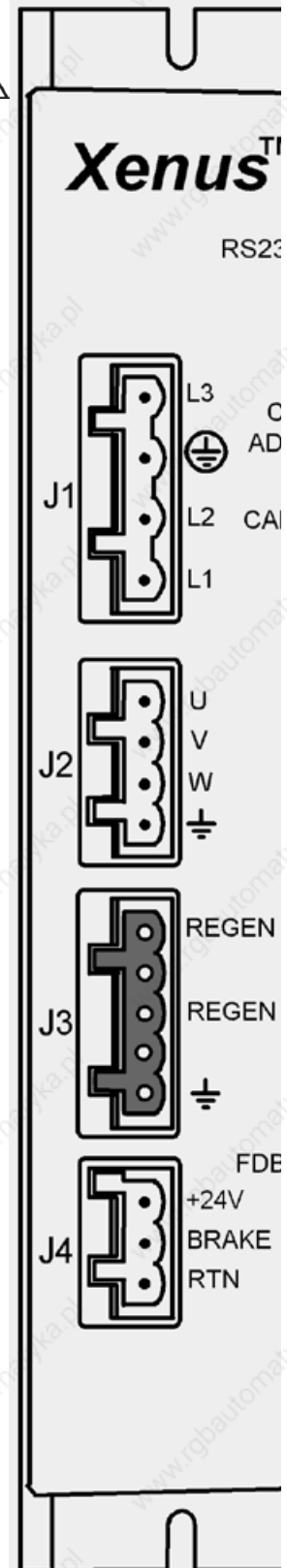

ISOLATED CIRCUIT

* Wago connector part numbers in () are RoHS compliant

J5 RS-232

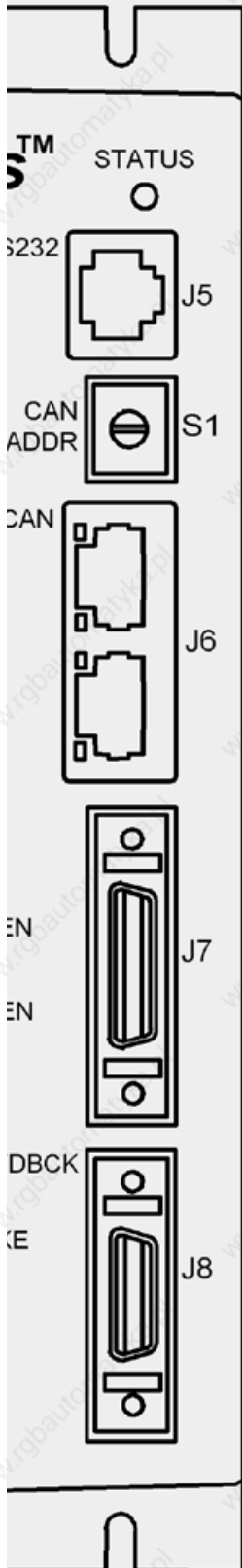

Pin	Signal
6	No connect
5	TxD Output
4	Ground
3	Ground
2	RxD Input
1	No connect

J5 Cable Connector:

RJ-11 style, male, 6 position
Cable: 6-conductor modular type

Notes:

1. CAN circuits are opto-isolated from drive circuits.
2. CAN_GND connects to drive Signal Ground.
3. CAN_SHLD and CAN_V+ are wired-thru on both J6 connectors and have no connection to the drive.

•• ISOLATED CIRCUIT ••

J6 CAN Bus

Pin	Signal
1	CAN_H
2	CAN_L
3	CAN_GND
4	No connection
5	No connection
6	(CAN_SHLD)
7	CAN_GND
8	(CAN_V+)

J6 Cable Connector:

RJ-45 style, male, 8 position
Cable: 8-conductor modular type

J8 Motor Feedback

Signal	Pin	Signal
Frame Ground	1	Digital Hall U
Signal Ground	2	Digital Hall V
+5 Vdc @ 400 mA	3	Digital Hall W
Encoder A Input	4	[IN5] Temp Sensor
Encoder /A Input	5	Signal Ground
Encoder B Input	6	Encoder Sin(+) Input
Encoder /B Input	7	Encoder Sin(-) Input
Encoder X Input	8	Encoder Cos(+) Input
Encoder /X Input	9	Encoder Cos(-) Input
Signal Ground	10	Signal Ground

J7 Control Signals

Signal	Pin	Signal
Frame Ground	1	[OUT2]
Signal Ground	2	[OUT3]
Enable [IN1]	3	Multi-Mode Encoder A
GP Input [IN2]	4	Multi-Mode Encoder /A
GP Input [IN3]	5	Multi-Mode Encoder B
GP Input [IN4]	6	Multi-Mode Encoder /B
HS Input [IN6]	7	Multi-Mode Encoder X
HS Input [IN7]	8	Multi-Mode Encoder /X
HS Input [IN8]	9	+5 Vdc @ 400 mA
HS Input [IN9]	10	Signal Ground
HS Input [IN10]	11	Ref(+) Input
GP Input [IN11]	12	Ref(-) Input
[OUT1]	13	[IN12] GP Input

J7 Cable Connector:

Solder Cup, 26 position male,
1.27 mm pitch

Cable: 26 conductor, shielded
Standard with Snap locks

3M: 10126-3000 VE connector

3M: 10326-52F0-008 backshell

Rugged with Screw-locks

Molex: 54306-2619 connector

Molex: 54331-0261 backshell

J8 Cable Connector:

Solder Cup, 20 position male,
1.27 mm pitch

Cable: 20 conductor, shielded
Standard with Snap locks

3M: 10120-3000VE connector

3M: 10320-52F0-008 backshell

Rugged with Screw-locks

Molex: 54306-2019 connector

Molex: 54331-0201 backshell

Note: Molded cable assemblies are available for J7 & J8.

See Accessories on last page

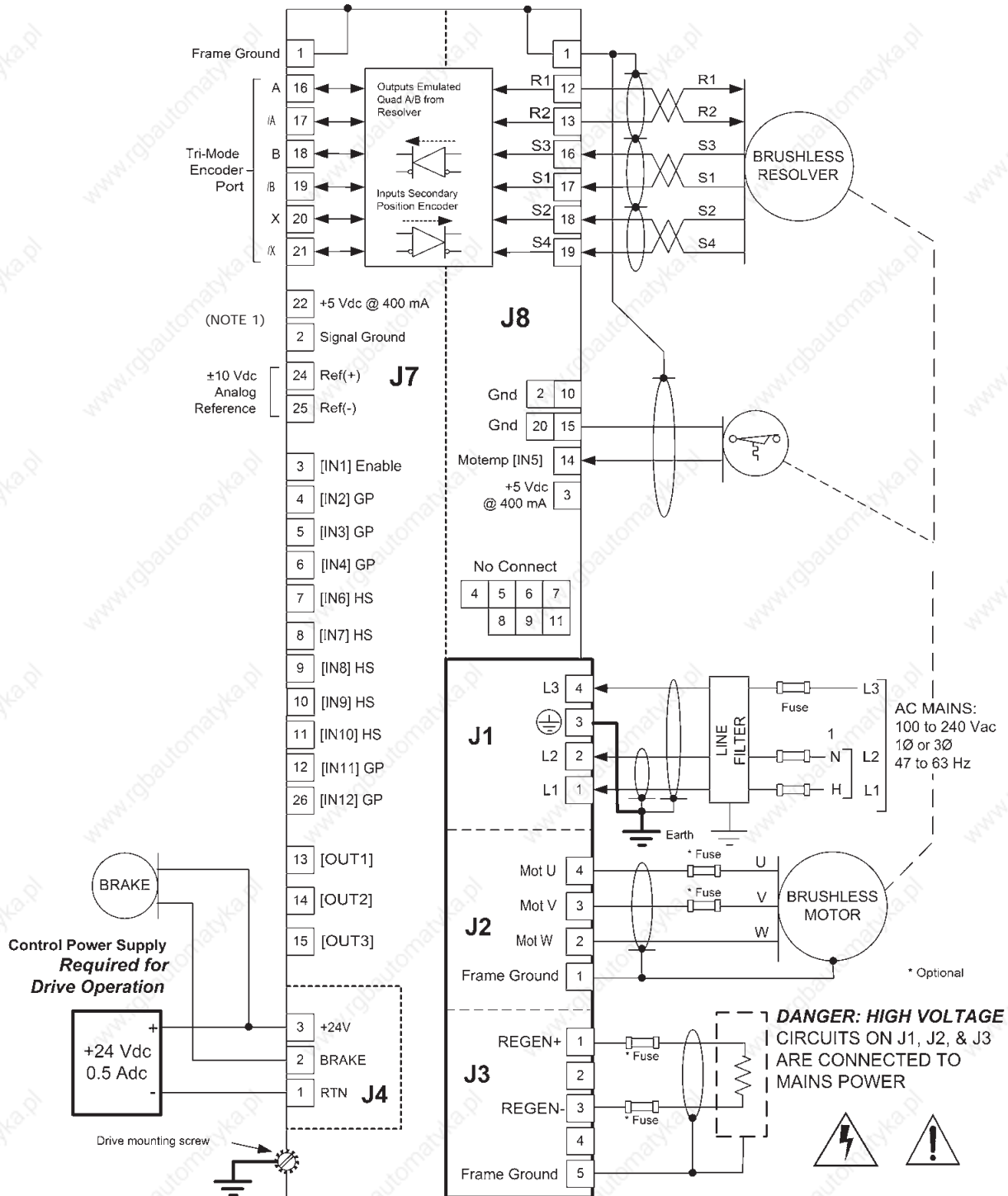

NOTES:

1. The total output current from the +5 Vdc supply to J7-22 and J8-3 cannot exceed 400 mA dc.

ACCESSORY CABLE CONNECTIONS

SIGNAL CABLE (XSL-CC-10)

Cable assembly: CCC p/n 59-00785-000
Molded connector mates with drive J7 and has flying-lead terminations.

CONNECTOR (FRONT VIEW)

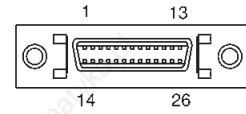

Signal	Pin	Color (Body/Stripe)	Pair	Color (Body/Stripe)	Pin	Signal
Frame Ground	1	Rev A & B: White/Tan Rev C: Brown	1a 8a	White/Violet	14	[OUT2]
Signal Ground	2	Rev A & B: Tan/White Rev C: Orange	1b 8b	Violet/White	15	[OUT3]
Enable [IN1]	3	White/Brown	2a 9a	White/Grey	16	Multi-Encoder A
GP Input [IN2]	4	Brown/White	2b 9b	Gray/White	17	Multi-Encoder /A
GP Input [IN3]	5	White/Pink	3a 10a	Tan/Brown	18	Multi-Encoder B
GP Input [IN4]	6	Pink/White	3b 10b	Brown/Tan	19	Multi-Encoder /B
HS Input [IN6]	7	White/Orange	4a 11a	Tan/Pink	20	Multi-Encoder X
HS Input [IN7]	8	Orange/White	4b 11b	Pink/Tan	21	Multi-Encoder /X
HS Input [IN8]	9	White/Yellow	5a 12a	Tan/Orange	22	+5 Vdc @ 400 mA
HS Input [IN9]	10	Yellow/White	5b 12b	Orange/Tan	23	Signal Ground
HS Input [IN10]	11	White/Green	6a 13a	Tan/Yellow	24	Analog Ref(+)
GP Input [IN11]	12	Green/White	6b 13b	Yellow/Tan	25	Analog Ref(-)
[OUT1]	13	White/Blue	7a 7b	Blue/White	26	[IN12] GP Input

FEEDBACK CABLE (XSL-FC-10)

Cable assembly: CCC p/n 59-00786-000
Molded connector mates with drive J7 and has flying-lead terminations.

CONNECTOR (FRONT VIEW)

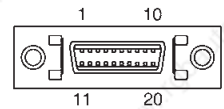

Signal	Pin	Color (Body/Stripe)	Pair	Color (Body/Stripe)	Pin	Signal
Frame Ground	1	Rev A & B: White/Tan RevC: Brown	1a 1b	Rev A & B: Tan/White Rev C: Orange	11	No connect
Signal Ground	2	White/Brown	2a 7a	White/Blue	12	Resolver R1 Output
+5 Vdc @ 400 mA	3	Brown/White	2b 7b	Blue/White	13	Resolver R2 Output
	4	White/Pink	3a 8a	White/Violet	14	[IN5] Temp Sensor
	5	Pink/White	3b 8b	Violet/White	15	Signal Ground
	6	White/Orange	4a 9a	White/Gray	16	Resolver S3 Input
	7	Orange/White	4b 9b	Gray/White	17	Resolver S1 Input
	8	White/Yellow	5a 10a	Tan/Brown	18	Resolver S2 Input
	9	Yellow/White	5b 10b	Brown/Tan	19	Resolver S4 Input
Signal Ground	10	White/Green	6a 6b	Green/White	20	Signal Ground

Note: Cable shields connect to connector shells and not to conductors. The shells of drive J7 & J8 are connected to the earth ground terminal on power connector J1 and to the drive chassis. When the cables above are connected to the drive a continuous path from cable shield to earth is established for shielding and CE compliance.



WARNING: Hazardous voltages exist on connections to J1, J2, & J3 when power is applied, and for up to 30 seconds after power is removed.



J1 Mains Connections

J1 CABLE CONNECTOR:

Wago 721-204/026-045
*(51118287 or 721-204/026-045/RN01-0000)
Euro-style 7,5 mm pluggable female terminal block with preceding ground receptacle
Cable: AWG 12, 600 V recommended for XSL-230-36 and XSL-230-40 models, AWG 14, 600V for XSL-230-18
Shielded cable required for CE compliance

Signal	Pin
Mains Input L3	4
Protective Ground	3
Mains Input L2	2
Mains Input L1	1

J2 CABLE CONNECTOR:

Wago 721-104/026-047
*(51118008 or 721-104/026-047/RN01-0000)
Euro-style 5,0 mm pluggable female terminal block
Cable: AWG 12, 600 V recommended for XSL-230-36 and XSL-230-40 models, AWG 14, 600V for XSL-230-18
Shielded cable required for CE compliance

J2 Motor Outputs

Signal	Pin
Motor Phase U	4
Motor Phase V	3
Motor Phase W	2
Cable Shield	1

J3 CABLE CONNECTOR:

Wago 721-605/000-043
*(51111279 or 721-605/000-044/RN01-0000)
Euro-style 5,0 mm pluggable male terminal block
Cable: AWG 12, 600 V recommended for XSL-230-36 and XSL-230-40 models, AWG 14, 600V for XSL-230-18
Shielded cable required for CE compliance

J3 Regen Resistor

Signal	Pin
Regen Resistor	1
No Connection	2
Regen Resistor	3
No Connection	4
Cable Shield	5

WIRE INSERTION/EXTRACTION TOOL:

Used on J1, J2, J3, & J4
Wago 231-131

ISOLATED CIRCUIT

NOTE: AN EXTERNAL +24 VDC POWER SUPPLY IS REQUIRED FOR OPERATION

J4 CABLE CONNECTOR:

Wago 721-103/026-047
*(51117974 or 721-103/026-047/RN01-0000)
Euro-style 5,0 mm pluggable terminal block

J4 +24 VDC & Brake

Signal	Pin
+24 Vdc Control Power	3
Brake Output [OUT4]	2
0V (+24 Vdc Return)	1

ISOLATED CIRCUIT

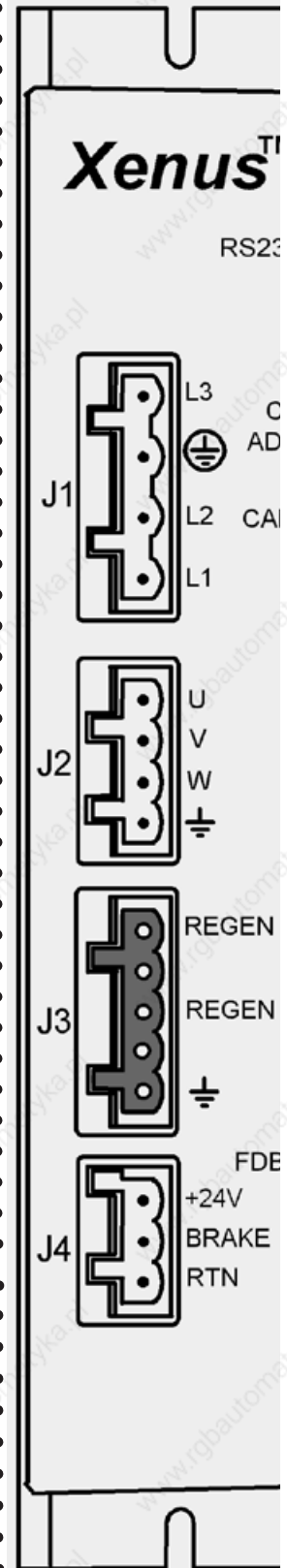

* Wago connector part numbers in () are RoHS compliant

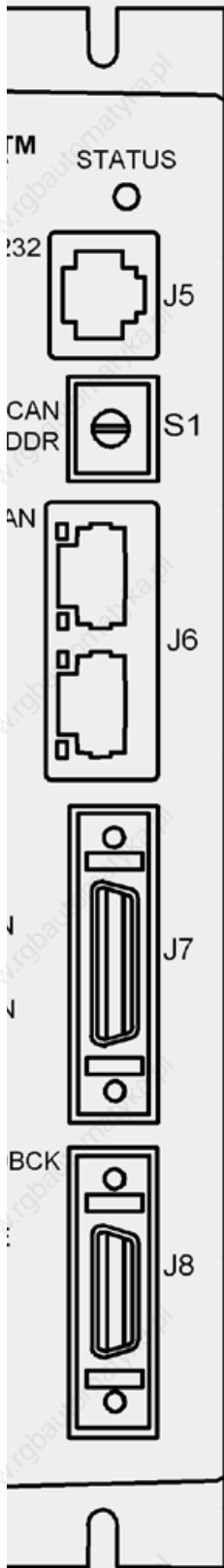

J5 RS-232

Pin	Signal
6	No connect
5	TxD Output
4	Ground
3	Ground
2	RxD Input
1	No connect

J5 Cable Connector:

RJ-11 style, male, 6 position
Cable: 6-conductor modular type

Notes:

1. CAN circuits are opto-isolated from drive circuits.
2. CAN_GND connects to drive Signal Ground.
3. CAN_SHLD and CAN_V+ are wired-thru on both J6 connectors and have no connection to the drive.

• • ISOLATED CIRCUIT • •

J6 CAN Bus

Pin	Signal
1	CAN_H
2	CAN_L
3	CAN_GND
4	No connection
5	No connection
6	(CAN_SHLD)
7	CAN_GND
8	(CAN_V+)

J6 Cable Connector:

RJ-45 style, male, 8 position
Cable: 8-conductor modular type

J8 Motor Feedback

Signal	Pin	Signal	
Frame Ground	1	11	No Connect
Signal Ground	2	12	Resolver R1 Output
+5 Vdc @ 400 mA	3	13	Resolver R2 Output
No Connect	4	14	[IN5] Temp Sensor
No Connect	5	15	Signal Ground
No Connect	6	16	Resolver S3 Input
No Connect	7	17	Resolver S1 Input
No Connect	8	18	Resolver S2 Input
No Connect	9	19	Resolver S4 Input
Signal Ground	10	20	Signal Ground

J7 Control Signals

Signal	Pin	Signal	
Frame Ground	1	14	[OUT2]
Signal Ground	2	15	[OUT3]
Enable [IN1]	3	16	Multi-Mode Encoder A
GP Input [IN2]	4	17	Multi-Mode Encoder /A
GP Input [IN3]	5	18	Multi-Mode Encoder B
GP Input [IN4]	6	19	Multi-Mode Encoder /B
HS Input [IN6]	7	20	Multi-Mode Encoder X
HS Input [IN7]	8	21	Multi-Mode Encoder /X
HS Input [IN8]	9	22	+5 Vdc @ 400 mA
HS Input [IN9]	10	23	Signal Ground
HS Input [IN10]	11	24	Ref(+) Input
GP Input [IN11]	12	25	Ref(-) Input
[OUT1]	13	26	[IN12] GP Input

J7 Cable Connector:

Solder Cup, 26 position male,
1.27 mm pitch
Cable: 26 conductor, shielded
Standard with Snap locks
3M: 10126-3000 VE connector
3M: 10326-52F0-008 backshell
Rugged with Screw-locks
Molex: 54306-2619 connector
Molex: 54331-0261 backshell

J8 Cable Connector:

Solder Cup, 20 position male,
1.27 mm pitch
Cable: 20 conductor, shielded
Standard with Snap locks
3M: 10120-3000VE connector
3M: 10320-52F0-008 backshell
Rugged with Screw-locks
Molex: 54306-2019 connector
Molex: 54331-0201 backshell

Note: Molded cable assemblies are available for J7 & J8.
See Accessories p. 18

DRIVE POWER SOURCES

An external +24 Vdc power supply is required, and powers an internal DC/DC converter that supplies all the control voltages for drive operation. Use of an external supply enables CAN communication with the drive when the mains power has been removed.

Power distribution in Xenus is divided into four sections: +24 Vdc, CAN, signal, and high-voltage. Each is isolated from the other and all are isolated from the chassis.

EXTERNAL +24 VDC

The primary side of the DC/DC converter operates directly from the external +24 Vdc supply and is isolated from other drive power sections. The Brake output [OUT4] operates in this section and is referenced to the +24 Vdc return (0V). It sinks current from an external load connected to the external +24 Vdc power source.

INTERNAL SIGNAL POWER

The signal power section supplies power for the DSP controller as well as logic inputs and outputs. Motor feedback signals such as Halls, encoder, and temperature sensor operate from this power source. All signal circuits are referenced to signal ground. This ground should connect to the control system circuit ground or common so that drive and controller inputs and output voltage levels work properly with each other.

MAINS POWER

Mains power drives the high-voltage section. It is rectified and capacitor-filtered to produce +HV which the PWM stage converts into voltages that drive either three phase brushless or DC brush motors. An internal solid-state switch together with an external power resistor provides dissipation during regeneration when the mechanical energy of the motor is converted back into electrical energy that must be dissipated before it charges the internal capacitors to an overvoltage condition. All the circuits in this section are "hot", that is, they connect directly to the mains and must be considered high-voltages and a shock hazard requiring proper insulation techniques during installation.

GROUNDING

A grounding system has three primary functions: safety, voltage-reference, and shielding. As a safety measure, the primary ground at J1-3 will carry fault-currents from the mains in the case of an internal failure or short-circuit of electronic components. Wiring to this is typically done with the green conductor with yellow stripe using the same gauge wire as that used for the mains. The pin on the drive at J1-3 is longer than the other pins on J1 giving it a first-make, last-break action so that the drive chassis is never ungrounded when the mains power is connected. This wire is a 'bonding' conductor that should connect to an earthed ground point and must not pass through any circuit

interrupting devices. *All of the circuits on J1, J2, and J3 are mains-connected and must never be grounded.* The ground terminals at J1-3, J2-1, and J3-1 all connect to the drive chassis and are isolated from all drive internal circuits.

Signal grounding references the drive control circuits to those of the control system. These controls circuits typically have their own earth connection at some point. To eliminate ground-loops it is recommended that the drive signal ground be connected to the control system circuit ground. When this is done the drive signal voltages will be referenced to the same 0 V level as the circuits in the control system. Small currents flow between controller and drive when inputs and outputs interact. The signal ground is the path for these currents to return to their power sources in both controller and drive.

Shields on cables reduce emissions from the drive for CE compliance and protect internal circuits from interference due to external sources of electrical noise. Because of their smaller wire gauge, these should not be used as part of a safety-ground system. Motor cases can be safety-grounded either at the motor, by earthing the frame, or by a grounding conductor in the motor cable that connects to J2-1. This cable should be of the same gauge as the other motor phase cables.

For CE compliance and operator safety, the drive should be earthed by using external tooth lockwashers under the mounting screws. These will make contact with the aluminum chassis through the anodized finish to connect the chassis to the equipment frame ground.

REGENERATION

The chart below shows the energy absorption in W-s for a Xenus drive operating at some typical mains voltages. When the load mechanical energy is greater than these values an external regen resistor is available as an accessory.

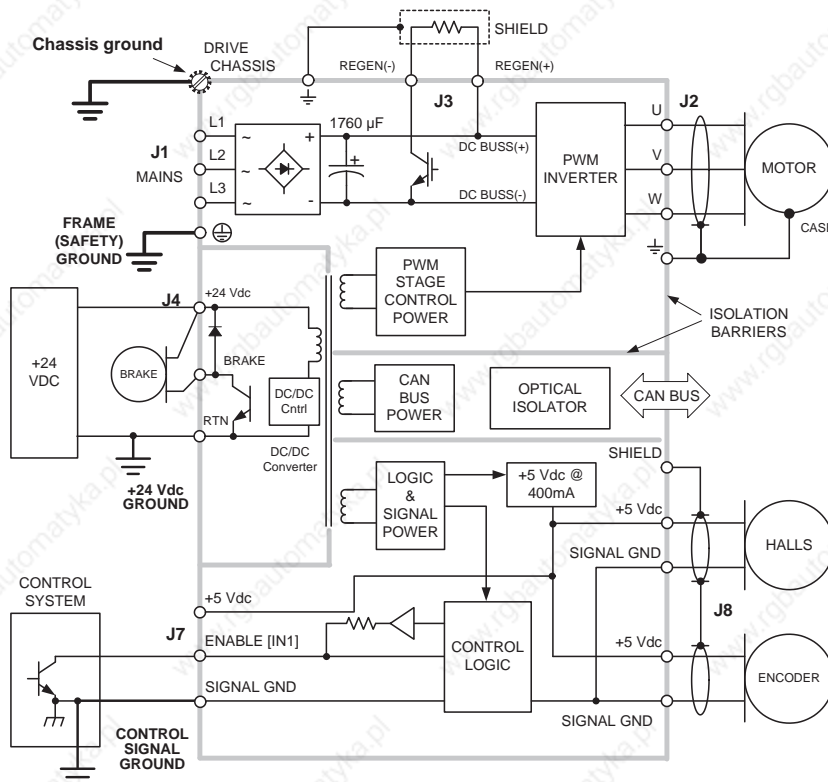
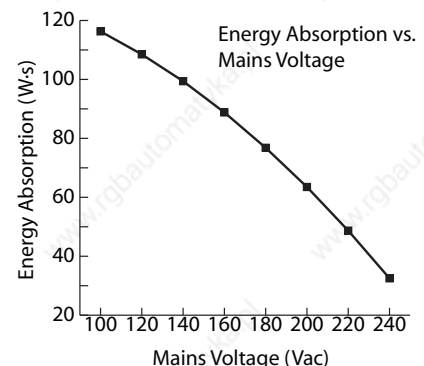

SINGLE-DRIVE SETUP FOR CANOPEN POSITION CONTROL

Xenus operates as a CAN node. All commands are passed on the CAN bus. CME 2 is used for setup and configuration before installation as CAN node.

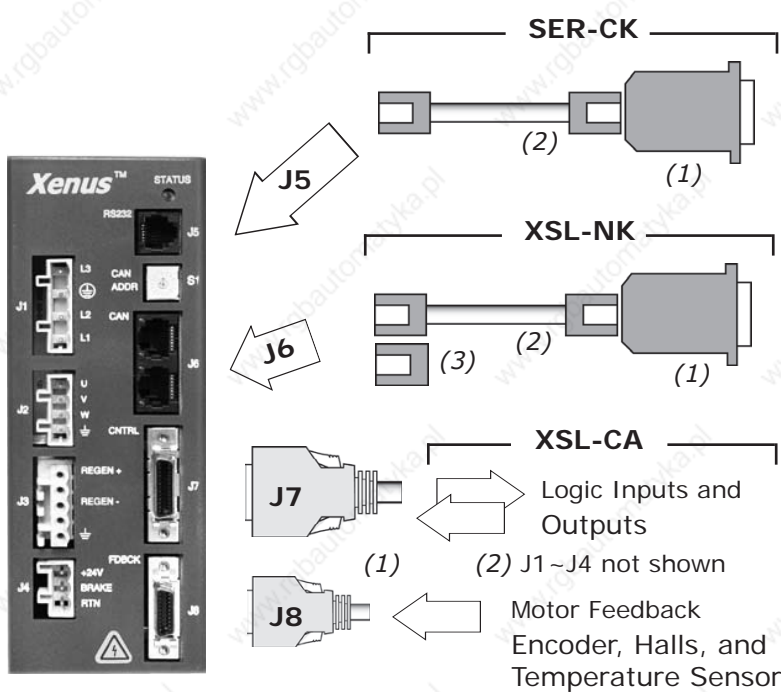





**COM1
COM2
COMx**



**CAN
CARD**



**PC or
Compatible**



CML C++ Libraries
Windows™ 95, 98, 2000,
ME, NT, and Linux



**CMO Copley Motion
Objects**
Windows™ 95, 98, 2000,
ME, NT, and Linux



CME 2
Windows® 95, 98, 2000,
ME, and NT

Computer:
PC or compatible with
166MHz with 64MB RAM minimum
266 MHz with 128MB RAM recommended
Serial port (RS-232)
CAN bus interface
Using the minimum requirements will allow CME 2 to run
but the performance will be significantly reduced.

Serial Cable Kit SER-CK

Connects a PC serial port to Xenus RX-232 connector J5
(1) RS-232 9-pin Sub-D to RJ-11 adapter
(2) 6 ft (2 m) RJ-11 cable

CANopen Network Kit XSL-NK

Connects a CAN card to Xenus connector J6 and includes terminator for 'last' drive on CAN bus
(1) CAN card 9-pin Sub-D to RJ-45 adapter
(2) 6 ft (2 m) RJ-45 cable
(3) CAN terminator

Connector/Cable Kit XSL-CA

Includes connectors J1~J4, J7 & J8:
(1) Molded 10 ft (3 m) cables for J7 & J8
(2) Wago connectors for J1~J4

Connector/Cable Kit XSL-CK

Includes connectors for J1~J4, J7, J8:
(1) Soldercup connectors for J7 & J8
(2) Wago connectors for J1~J4

See diagram on page 7 for connections to:

- J1 AC mains power
- J2 Motor phases
- J3 Regen resistor
- J4 +24 Vdc Aux Power

ORDERING GUIDE

This table shows parts to order for the configuration on this page
See page 23 for other parts required (motor, +24 Vdc power supply, etc.)

PART NUMBER	DESCRIPTION
XSL-230-18	Xenus XSL Servodrive 6/18 A
XSL-230-36	Xenus XSL Servodrive 12/36 A
XSL-230-40	Xenus XSL Servodrive 20/40 A
XSL-NK	CANopen Network Kit
XSL-CK	Xenus Solder-Cup Connector Kit
XSL-CA	Xenus Molded-Cable Connector Kit
CME2	CME 2 Configuration Software CD
SER-CK	CME 2 RS-232 Cable Kit
XSL-HS	Heatsink, Standard (Optional)
XSL-HL	Heatsink, Low-Profile (Optional)
XTL-RA-03	Regen resistor, 30 Ω (Optional)
XTL-RA-04	Regen resistor, 10 Ω (Optional)

Add -R to Xenus part number for resolver feedback model

MULTIPLE-DRIVE SETUP FOR CANOPEN POSITION CONTROL

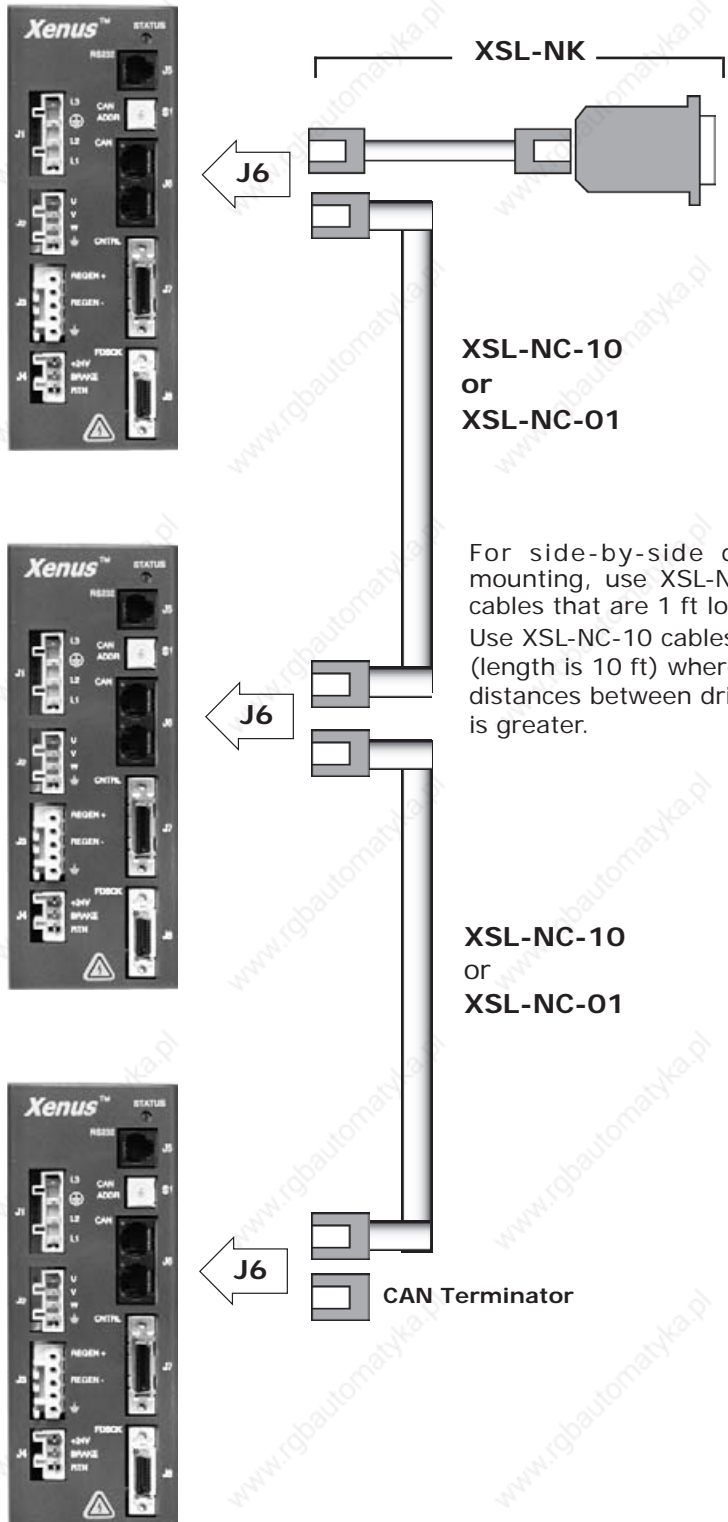

For multiple-drive installations, use the ordering guide on this page. Computer equipment is the same as for single-drive installations. And Serial Cable Kit SER-CK is used when CME 2 is in use for drive set up and configuration.

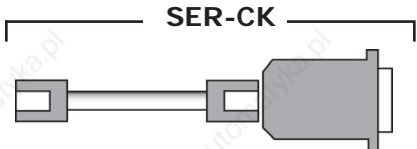

ORDERING GUIDE

This table shows parts to order for the configuration on this page. See page 23 for other parts required (motor, +24 Vdc power supply, etc.)

PART NUMBER	DESCRIPTION
XSL-230-18	Xenus XSL Servodrive 6/18 A
XSL-230-36	Xenus XSL Servodrive 12/36 A
XSL-230-40	Xenus XSL Servodrive 20/40 A
XSL-NK	CANopen Network Kit
XSL-NC-10	CAN Network Cable, 10 ft (3 m)
XSL-NC-01	CAN Network Cable, 1 ft (0.3 m)
XSL-CK	Xenus Solder-Cup Connector Kit
XSL-CA	Xenus Molded-Cable Connector Kit
CME2	CME 2 Configuration Software CD
SER-CK	CME 2 RS-232 Cable Kit
XSL-HS	Heatsink, Standard (Optional)
XSL-HL	Heatsink, Low-Profile (Optional)
XTL-RA-03	Regen resistor, 30 Ω (Optional)
XTL-RA-04	Regen resistor, 10 Ω (Optional)

Add -R to Xenus part number for resolver feedback model

STAND-ALONE OPERATION

Xenus takes digital position commands in Pulse/Direction, or CW/CCW format from an external controller or quadrature encoder signals from a master-encoder for electronic gearing. Velocity or torque control can be from $\pm 10V$, digital PWM signals.
CME 2 used for setup and configuration.

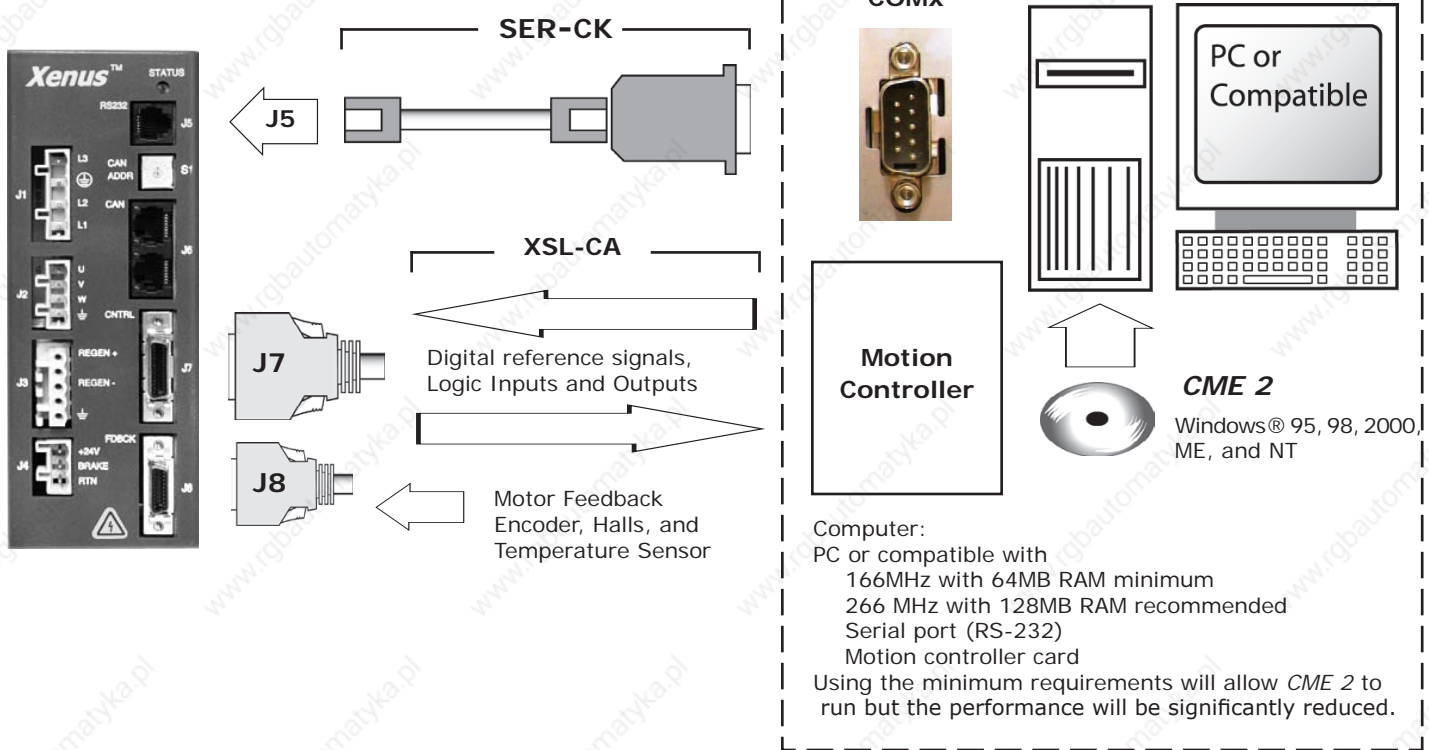

ORDERING GUIDE

This table shows parts to order for the configuration on this page
See page 23 for other parts required (motor, +24 Vdc power supply, etc.)

PART NUMBER	DESCRIPTION
XSL-230-18	Xenus XSL Servodrive 6/18 A
XSL-230-36	Xenus XSL Servodrive 12/36 A
XSL-230-40	Xenus XSL Servodrive 20/40 A
XSL-CK	Xenus Solder-Cup Connector Kit
XSL-CA	Xenus Molded-Cable Connector Kit
CME2	CME 2 Configuration Software CD
SER-CK	CME 2 RS-232 Cable Kit
XSL-HS	Heatsink, Standard (Optional)
XSL-HL	Heatsink, Low-Profile (Optional)
XTL-RA-03	Regen resistor, 30 Ω (Optional)
XTL-RA-04	Regen resistor, 10 Ω (Optional)

Add -R to Xenus part number for resolver feedback model

PARTS USED IN ALL CONFIGURATIONS

Each component is labeled *Required*, *Optional*, or *CE*.
Required components are necessary for operation of Xenus in all cases.
Optional components depend on the particular application.
CE after Required indicates that these parts are necessary for CE compliance.

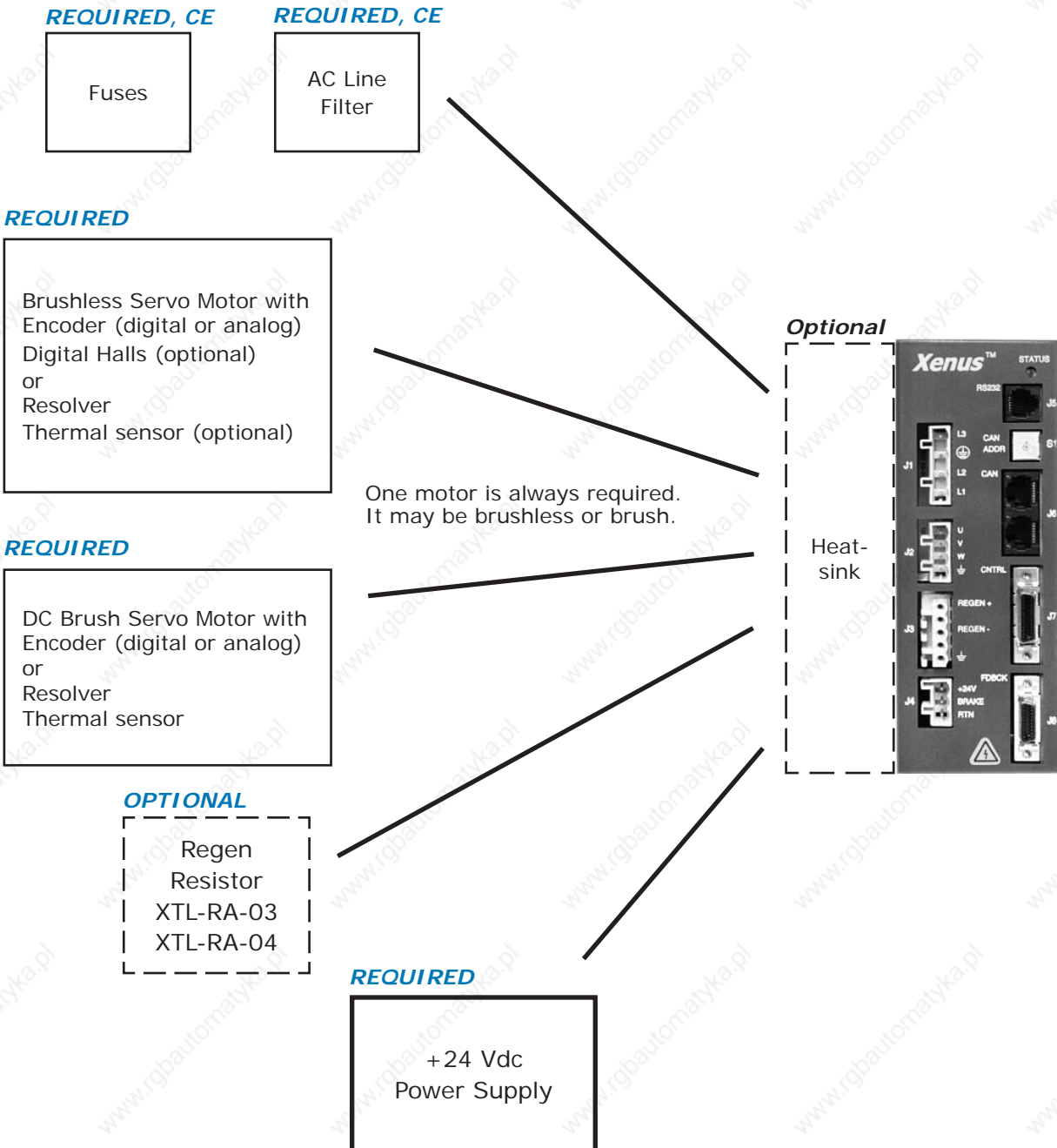

INSTALLATION

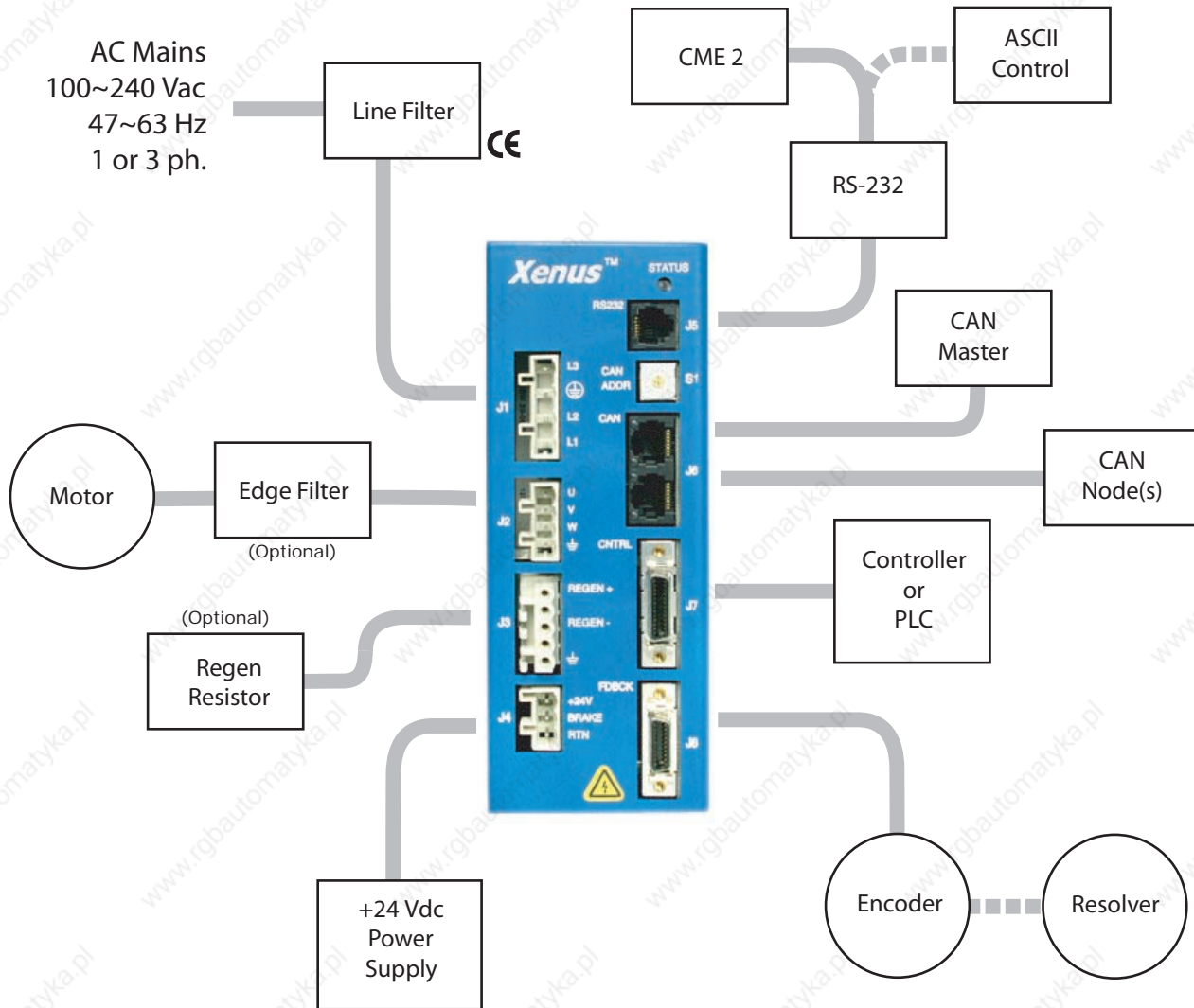

NEW FEATURES

		Model No: ACP-090-18 Serial No: 02057242 Made in U.S.A.	
Volts	Input Amps	Volts	Output Amps
20-90	20 pk.	90 max.	6 cont. 18 pk.

Xenus Encoder models manufactured after March, 2005 have enhanced features and can be identified by the red square on the label. The new features are:

- Indexing
- ASCII communications
- Multi-mode encoder port
 - Emulated encoder outputs from ServoTube motors
 - Buffered digital encoder outputs
 - Secondary encoder input

HEATSINK & FAN CONFIGURATIONS

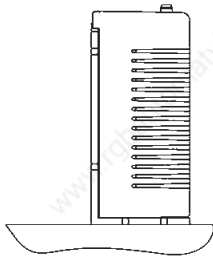

NO HEATSINK
NO FAN



NO HEATSINK
WITH FAN

NOTE: FANS ARE NOT INCLUDED
WITH HEATSINKS OR HEATSINK
KITS

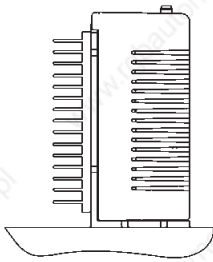

LOW-PROFILE
HEATSINK
NO FAN



LOW PROFILE HEATSINK
WITH FAN

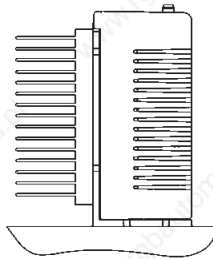

STANDARD HEAT-
SINK
NO FAN

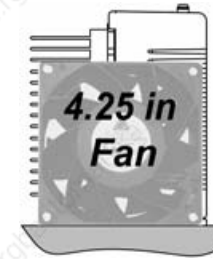

STANDARD HEATSINK
WITH FAN

HEATSINK MOUNTING

A dry-film interface pad is used in place of thermal grease. The pad is die-cut to shape and has holes for the heat sink mounting screws. There are two protective sheets, blue on one side and clear on the other. Both must be removed when the interface pad is installed.

STEPS TO INSTALL

1. Remove the blue protective sheet from one side of the pad and place the pad on the drive. Make sure that the holes in the pad align with the holes on the drive.
2. Remove the clear protective sheet from the pad.
3. Mount the heatsink onto the drive taking care to see that the holes in the heatsink, pad, and drive all line up.
4. Torque the #6-32 mounting screws to 8-10 lb-in (0.9-1.13 N·m).

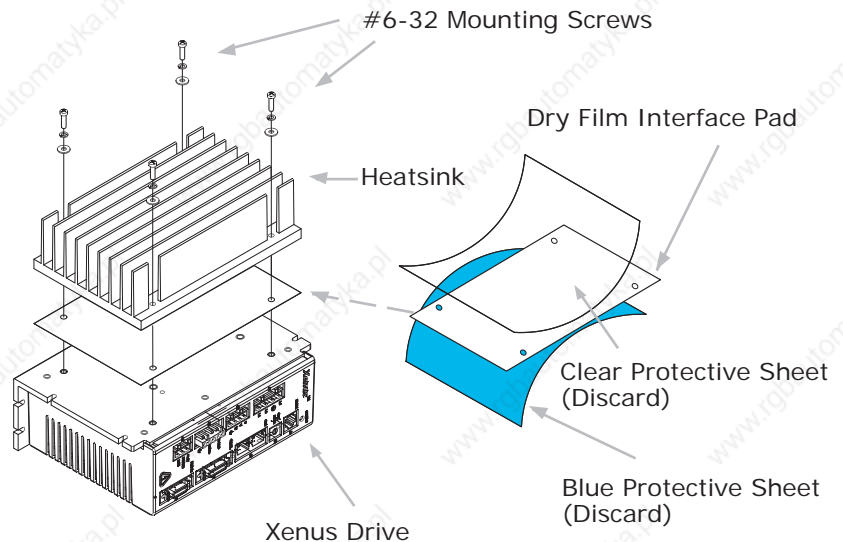

MAXIMUM OPERATING TEMPERATURE VS HEATSINK TYPE & AIR CIRCULATION

The charts below show that maximum ambient temperature vs. continuous output current for the Xenus models. The cooling options are no heatsink, standard heatsink, and low-profile heatsink. For each of these the drive can be operated with convection or forced-air cooling.

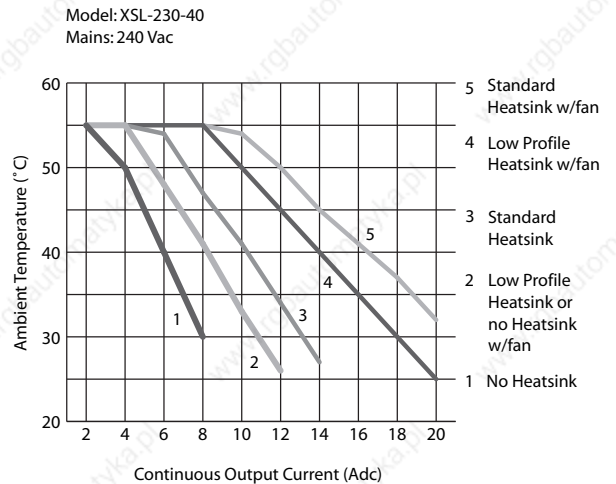
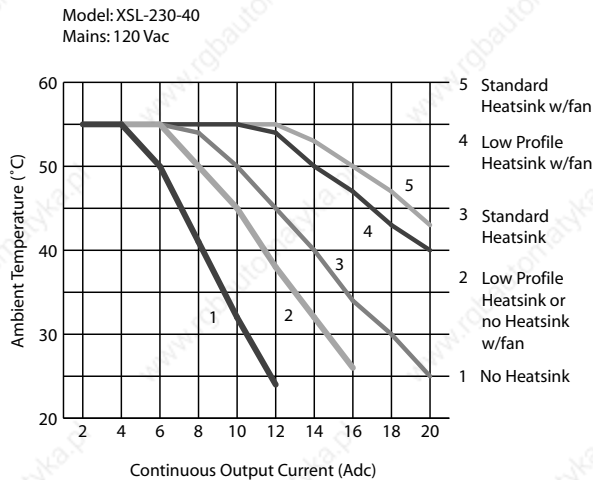
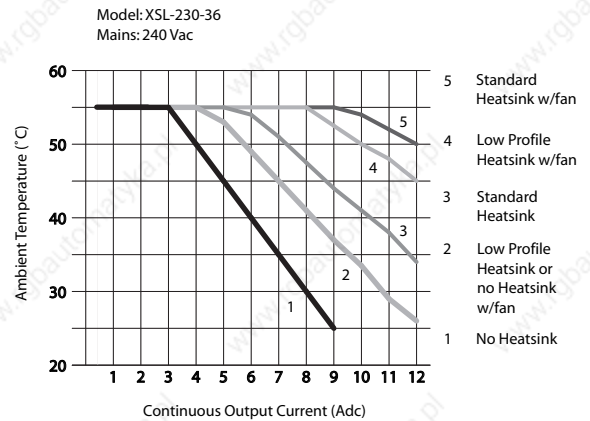
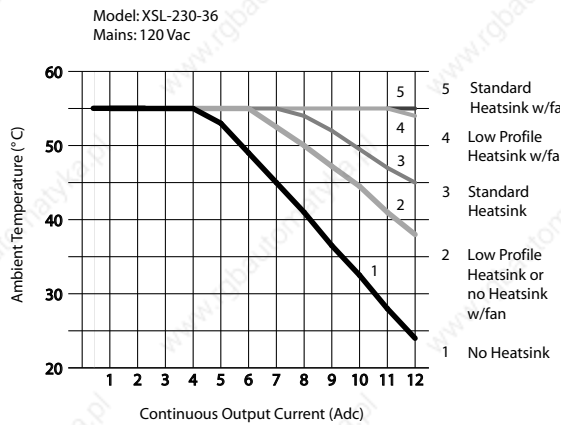
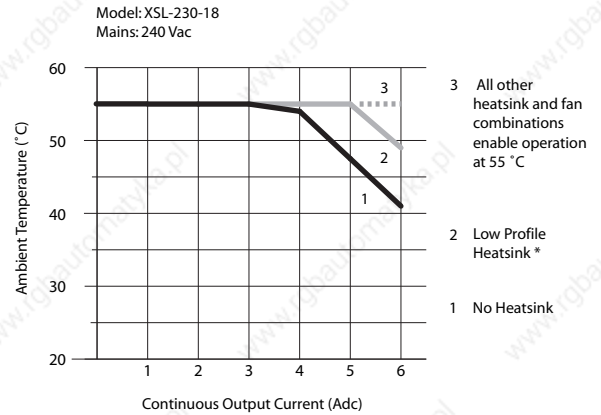
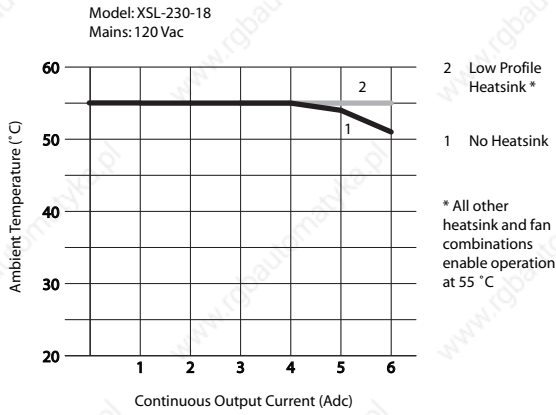

ORDERING GUIDE

ENCODER	RESOLVER	DESCRIPTION
XSL-230-18	XSL-230-18-R	<i>Xenus Servo Drive 6/18 Adc</i>
XSL-230-36	XSL-230-36-R	<i>Xenus Servo Drive 12/36 Adc</i>
XSL-230-40	XSL-230-40-R	<i>Xenus Servo Drive 20/40 Adc</i>

Example: Order one Xenus drive, resolver version, 6/18 A with solder-cup connector Kit, CME 2 CD, serial cable kit and small heatsink fitted at the factory:

Qty	Item	Remarks
1	XSL-230-18-R-HS	Xenus servo drive
1	XSL-CK	Connector Kit
1	CME 2	CME 2 CD
1	SER-CK	Serial Cable Kit

Note: The heatsink can be fitted at the factory by adding an "-HS" or "-HL" to the drive part number to specify the standard or low-profile type. For fitting a heatsink to an drive in the field, complete kits are available (XSL-HS and XSL-HL). These kits contain the heatsink, mounting hardware, and dry-film interface.

ACCESSORIES

	QTY	REF	DESCRIPTION	MANUFACTURERS PART NUMBER
XSL-CK Connector Kit with Solder Cup Connectors for J7 & J8	1	J1	Plug, 4 position, 7.5 mm, female	Wago: 721-204/026-045 (Note 1)
	1	J2	Plug, 4 position, 5.0 mm, female	Wago: 721-104/026-047 (Note 1)
	1	J3	Plug, 5 position, 5.0 mm, male	Wago: 721-605/000-044 (Note 1)
	1	J4	Plug, 3 position, 5.0 mm, female	Wago: 721-103/026-047 (Note 1)
	4	J1-4	Tool, wire insertion & extraction (for J1-4)	Wago: 231-131
	1	J7	Connector, 26 position, solder-cup	3M: 10126-3000VE
	1		Back shell, for 26 position connector	3M: 10326-52F0-008
	1	J8	Connector, 20 position, solder cup	3M: 10120-3000VE
1	Back shell, for 20 position connector		3M: 10320-52F0-008	
XSL-CA Connector Kit with Molded Cables for J7 & J8	1	J1	Plug, 4 position, 7.5 mm, female	Wago: 721-204/026-045 (Note 1)
	1	J2	Plug, 4 position, 5.0 mm, female	Wago: 721-104/026-047 (Note 1)
	1	J3	Plug, 5 position, 5.0 mm, male	Wago: 721-605/000-044 (Note 1)
	1	J4	Plug, 3 position, 5.0 mm, female	Wago: 721-103/026-047 (Note 1)
	4	J1-4	Tool, wire insertion & extraction (for J1-4)	Wago: 231-131
	1	J7	Cable assembly, control, 10 ft (3 m)	Molex: 52316-2611, plug assy, Molex 52370-2610 boot cover
	1	J8	Cable assembly, feedback, 10 ft (3 m)	Molex: 52316-2011, plug assy, Molex 52370-2010 boot cover
XSL-CC-10		J7	Cable + molded connector, control, 10 ft (3 m)	Molex: 52316-2611, plug assy, Molex 52370-2610 boot cover
XSL-FC-10		J8	Cable + molded connector, feedback, 10 ft (3 m)	Molex: 52316-2011, plug assy, Molex 52370-2010 boot cover
CME 2		J5	CME 2 Drive Configuration Software (CD-ROM)	
SER-CK			RS-232 Cable Kit	

Note 1: For RoHS compliance, append "/RN01-0000" to the part numbers listed above

Connectors & Software for CANOpen Operation

XSL-NK	1	J6	D-Sub 9F to RJ-45 Adapter	XSL-CV
	1		CAN bus RJ-45 terminator	XSL-NT
	1		CAN bus network cable, 10 ft (3 m)	PC Connection Item#: 222440, Ethernet Patch cable, 10 ft
XSL-CV			D-Sub 9F to RJ-45 Adapter	
XSL-NC-10			CAN bus Network Cable, 10 ft (3 m)	PC Connection Item#: 222440, Ethernet Patch cable, 10 ft
XSL-NC-01			CAN bus Network Cable, 1 ft (0.3 m)	PC Connection Item#: 413209, Ethernet Patch cable, 1 ft.
XSL-NT			CAN bus Network Terminator	
CMO	1		CD with CMO Software	
CML	1		CD with CML Software (Note: license fee required)	

Heatsink Kits for Field Installation (Optional)

XSL-HL Heatsink Kit Low-Profile	1	Heatsink, low-profile	
	1	Heatsink thermal material	
	4	Heatsink hardware	
XSL-HS Heatsink Kit Standard	1	Heatsink, standard	
	1	Heatsink thermal material	
	4	Heatsink hardware	

Regeneration Resistors (Optional)

XTL-RA-03	Regeneration resistor assembly (for XSL-230-18)
XTL-RA-04	Regeneration resistor assembly (for XSL-230-36 & XSL-230-40 models)

Edge Filter (Optional)

XSL-FA-01	Edge filter
XSL-FK	Edge filter connector kit