

Rexroth MKD Synchronous motors

R911272495
Edition 07

Project Planning Manual



Title	Rexroth Synchronous motors MKD
Type of Documentation	Project Planning Manual
Document Typecode	DOK-MOTOR*-MKD*****-PR07-EN-P
Internal File Reference	Part No.: R911272495 Document Number: 120-1500-B302-07/EN
Purpose of Documentation	This documentation ... <ul style="list-style-type: none"> • explain the product qualities, possible applications, technical data, operating conditions and limits. • Gives indications for the product choice, handling and operating.

Record of Revisions

Description	Release Date	Notes
DOK-MOTOR*-MKD*****-PRJ1-EN-P	09.96	1 st edition
DOK-MOTOR*-MKD*****-PRJ2-EN-P	01.97	Revision
DOK-MOTOR*-MKD*****-PR05-EN-P	02.99	Revision
DOK-MOTOR*-MKD*****-PR06-EN-P	06.02	Revision
DOK-MOTOR*-MKD*****-PR07-EN-P	05.04	Revision

Copyright © 2004 Bosch Rexroth AG

Copying this document, giving it to others and the use or communication of the contents thereof without express authority, are forbidden. Offenders are liable for the payment of damages. All rights are reserved in the event of the grant of a patent or the registration of a utility model or design (DIN 34-1).

Validity The specified data is for product description purposes only and may not be deemed to be guaranteed unless expressly confirmed in the contract. All rights are reserved with respect to the content of this documentation and the availability of the product.

Published by Bosch Rexroth AG
Bgm.-Dr.-Nebel-Str. 2 • D-97816 Lohr a. Main
Telephone +49 (0)93 52/40-0 • Tx 68 94 21 • Fax +49 (0)93 52/40-48 85
<http://www.boschrexroth.com/>
Dept. BRC/EDM2 (JW)

Note This document has been printed on chlorine-free bleached paper.

Contents

1	Introduction	1-1
1.1	Product Presentation.....	1-1
1.2	About this Documentation.....	1-4
2	Important Instructions on Use	2-1
2.1	Intended Use.....	2-1
	Introduction	2-1
	Fields of Use and Application	2-2
2.2	Non-Intended Use	2-2
3	Safety Instructions for Electric Drives and Controls	3-1
3.1	Introduction	3-1
3.2	Explanations	3-1
3.3	Hazards by Improper Use.....	3-2
3.4	General Information.....	3-3
3.5	Protection Against Contact with Electrical Parts.....	3-5
3.6	Protection Against Electric Shock by Protective Low Voltage (PELV).....	3-6
3.7	Protection Against Dangerous Movements	3-7
3.8	Protection Against Magnetic and Electromagnetic Fields During Operation and Mounting.....	3-9
3.9	Protection Against Contact with Hot Parts.....	3-10
3.10	Protection During Handling and Mounting.....	3-11
3.11	Battery Safety.....	3-12
3.12	Protection Against Pressurized Systems.....	3-13
4	MKD Type Code	4-1
5	General Notes on Technical Data	5-1
5.1	60-K and 100-K Parameters	5-1
5.2	Operating Modes.....	5-2
5.3	Definition of Parameters	5-3
5.4	Sample Curve	5-5
6	MKD025	6-1
6.1	Technical Data	6-1
	Holding brake	6-4
6.2	Type code – Ordering type	6-5
6.3	Speed – Torque – Characteristics	6-6
6.4	Shaft Load	6-8

6.5	Dimensions	6-9
7	MKD041	7-1
7.1	Technical Data	7-1
	Holding Brake	7-4
7.2	Type code – Ordering Name	7-5
7.3	Speed – Torque – Characteristics.....	7-6
7.4	Shaft Load	7-8
7.5	Dimensions	7-9
8	MKD071	8-1
8.1	Technical Data	8-1
	Holding brake	8-4
8.2	Type code – Ordering Name	8-5
8.3	Speed – Torque – Characteristics.....	8-6
8.4	Shaft Load	8-8
8.5	Dimensions	8-9
8.6	Blower Units.....	8-11
9	MKD090	9-1
9.1	Technical Data	9-1
	Holding Brake.....	9-5
9.2	Type code – Ordering Name	9-6
9.3	Speed – Torque – Characteristics.....	9-7
9.4	Shaft Load	9-9
9.5	Dimensions	9-10
9.6	Blower Units.....	9-11
10	MKD112	10-1
10.1	Technical Data	10-1
	Holding Brake.....	10-9
10.2	Type code – Ordering Name	10-10
10.3	Speed – Torque – Characteristics.....	10-11
10.4	Shaft Load	10-14
10.5	Dimensions	10-15
10.6	Blower Units.....	10-17
11	Accessories	11-1
11.1	Sealing Air Connection Accessories	11-1
11.2	Gearings	11-2
	GTS, GTP Planetary Gearings.....	11-2
	Screw Gearings 058.....	11-3
12	Connection System	12-1
12.1	Overview of Connections.....	12-1
12.2	Motors with connector box.....	12-2

Connection diagram	12-2
12.3 Motors with connector receptacle	12-4
Connection diagram	12-4
12.4 Blower connector	12-6
Type (1)	12-6
Connecting and mounting the blower	12-7
12.5 Connection Cable	12-8
Dimensioning of power cable	12-8
Selection of connection cable	12-9
13 Application Instructions	13-1
13.1 Operating Conditions	13-1
Setup Height and Ambient Temperature	13-1
Vibration and Shock Loads	13-2
13.2 Degree of protection	13-3
Option sealing air "sealing air: principle" connection	13-4
Selecting the Degree of Protection	13-5
13.3 Design and Installation Positions	13-6
Prime Coat and Housing Varnish	13-6
13.4 Blower	13-7
13.5 Holding Brakes	13-8
13.6 Output Shaft and Motor Bearing	13-9
Plain shaft	13-9
Output shaft with key	13-9
Output Shaft with Shaft Sealing Ring	13-10
Bearings and Shaft Load	13-11
13.7 Motor Encoder	13-13
13.8 Acceptances, Approvals	13-14
CE mark	13-14
UR, cUR Listing	13-14
14 Handling	14-1
14.1 Identifying the Goods	14-1
14.2 Type Labels	14-1
14.3 Instructions on the Packing	14-2
14.4 Storage	14-3
14.5 Transport and Handling	14-3
15 Assembly	15-1
15.1 Skilled Technical Personnel	15-1
15.2 Mounting the Motor	15-1
15.3 Connecting the Motor	15-3
Motor with connection box	15-4
Motors with plug-in connectors	15-6
16 Startup, Operation, and Maintenance	16-1

16.1 Startup	16-1
16.2 Operation	16-1
16.3 Maintenance	16-2
Cleaning	16-2
Bearings	16-2
Connection Cable	16-2
Holding brake	16-3
Changing the battery	16-4
17 Appendix	17-1
17.1 List of Standards	17-2
17.2 Selecting Power Cables	17-3
INS0680 1,0mm ²	17-5
INS0542 1,0mm ²	17-6
INS0480 1,5mm ²	17-7
INS0480 2,5mm ²	17-8
INS0480 4,0mm ²	17-9
INS0480 6,0mm ²	17-10
INS0480 10,0mm ²	17-11
INS0380 6,0mm ²	17-12
INS0380 10,0mm ²	17-13
INS0380 16,0mm ²	17-14
17.3 Selecting Encoder Cables	17-15
18 Index	18-1
19 Service & Support	19-1
19.1 Helpdesk	19-1
19.2 Service-Hotline	19-1
19.3 Internet	19-1
19.4 Vor der Kontaktaufnahme... - Before contacting us... ..	19-1
19.5 Kundenbetreuungsstellen - Sales & Service Facilities	19-2

1 Introduction

This chapter describes how to use the present documentation (refer to the chapter entitled "About this Documentation") and includes a general representation of the product in Chapter 1.1.

1.1 Product Presentation

Fields of application In connection with the digital intelligent drive controllers by Rexroth, the digital MKD AC motors offer cost-effective automation systems with an extensive functionality for the following fields of application:

- Machine tools
- Printing and paper industries
- Handling and automation
- Packaging machines and food
- Food industry (selected motor types style "non-painted").

Benefits MKD motors are characterized by the following advantages:

- High operational reliability
- Maintenance-free operation (owing to the brushless design and use of bearings grease-lubricated for their entire service life)
- Use under adverse environmental conditions is possible (owing to the completely closed motor design in IP 65 degree of protection)
- Overload protection (owing to motor temperature monitoring)
- High performance data
- High dynamics (owing to the favorable ratio of torque to inertia mass)
- High overload capability (owing to the favorable heat dissipation from the stator windings to the outside wall of the motor housing)
- Peak torque utilizable across a wide speed range (owing to electronic commutation)
- Continuous start-stop operation possible with high repeat frequencies (owing to electrical commutation)
- Easy attachment to the machine (owing to flange according to DIN 42948)
- Any installation position desired
- Direct overhung mounting of pinions and belt pulleys (owing to the bearing being designed for high radial loads)
- Easy cabling (owing to cable sets, available in various designs)
- Simple and quick startup (owing to data memory in the motor encoder unit)

Performance overview Motors with the following continuous torques at standstill are available:

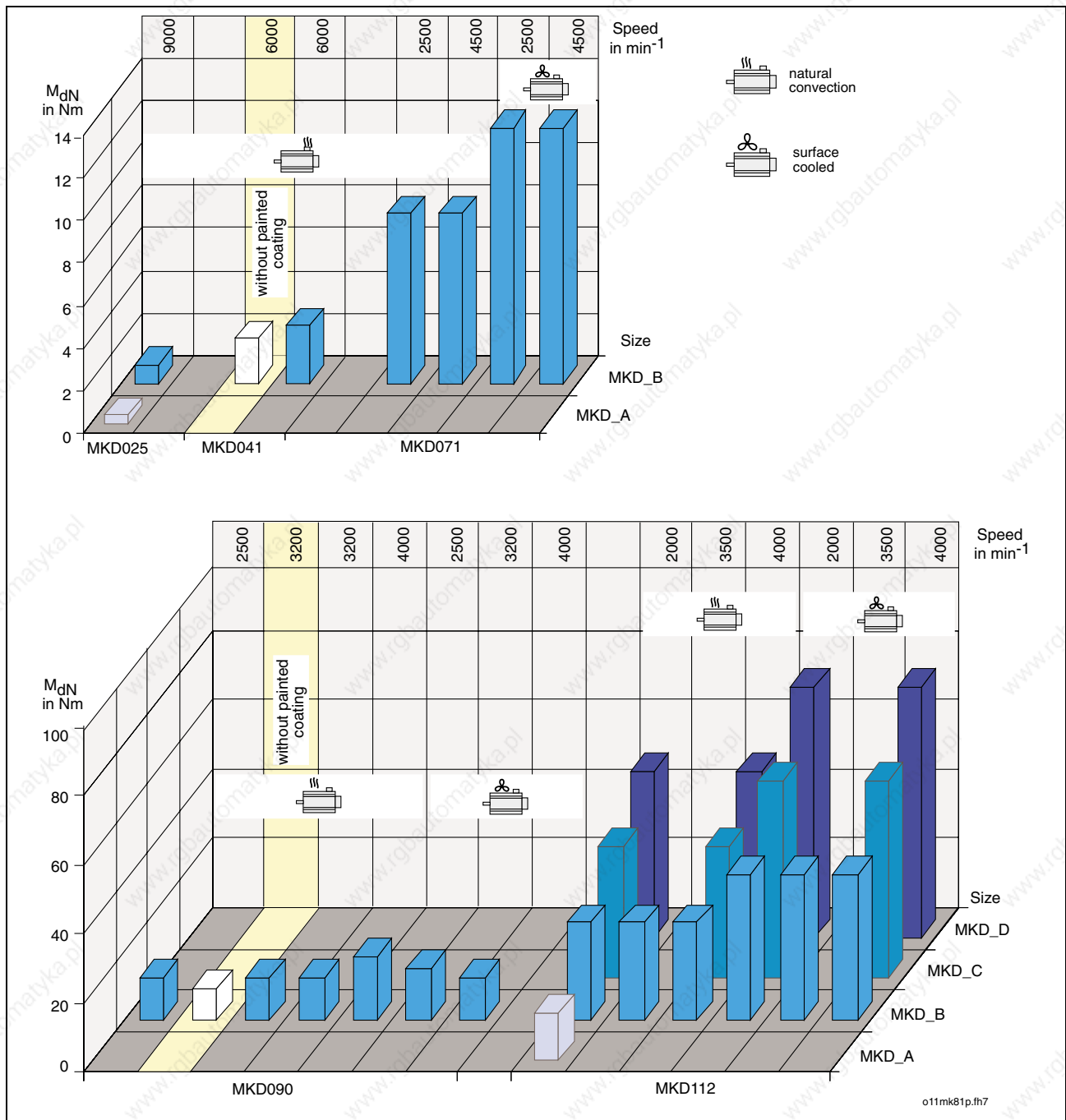

Fig. 1-1: Continuous torques at standstill of the available MKD motors

Note: For Information about MKD motors in ATEX-Design (Ex II3 GDx EEx NA II T155°C) use the Documentation DOK-MOTOR*-MKD*EXGIIK3-PRxx-DE-P.

Design and components MKD motors are permanent-magnet motors with electronic commutation. Special magnet materials permit the motors to be designed with low inertia masses. The following figure shows the principal design of MKD motors.

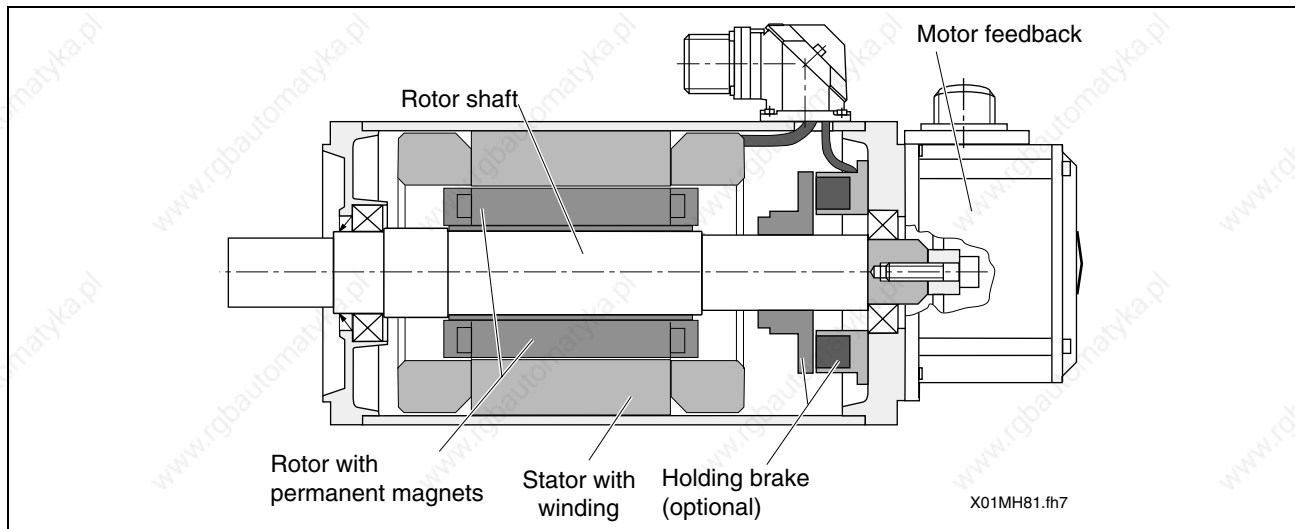

Fig. 1-2: Design of MKD motors

MKD motors are available in various designs. Please refer to the chapter on type codes for more detailed information.

1.2 About this Documentation

Structure of this Document Edition

The present documentation contains safety regulations, technical data, and operating instructions for MKD motors. The chapters can be subdivided in the following focal points with regard to their contents:

Chapter	Title		
1	Introduction	General information	
2	Important Instructions on Use	Safety Required reading	
3	Safety Instructions on Electric Drives and Controls		
4	MKD Type Code	Product description Planners and projectors	
5	General Notes on Technical Data		
6	MKD025		
7	MKD041		
8	MKD071		
9	MKD090		
10	MKD112		
11	Accessories		
12	Connection System		Practice Operating and main- tenance personnel
13	Application Instructions		
14	Handling		
15	Assembly		
16	Startup, Operation, and Maintenance		
17	Service and Support		
18	Appendix	Additional information	

Fig. 1-3: Document structure

Modifications as Compared with the Predecessor Version

The following list shows the modifications as compared with the predecessor version DOK-MOTOR*-MKD*****-PR06 -EN-P

Where?	What?
Chapters 6-10	New: Motors MKD025B-058, MKD071B-024 New: Technical data blower MKD071, MKD090, MKD112
Chapter 17	New: connecting cable and drive controllers supplemented

Fig. 1-4: Modifications

Note: This list does not lay claim to completeness. The author reserves the right to neglect minor modifications in this list.

Advanced documentation

Note: If the present documentation contains references to advanced documentations, the version of the latter is always represented in bold and underlined type (e.g. **06**). If documentations are ordered, their version may be a higher one!

Standards

This documentation refers to German, European and international technical standards. Documents and sheets on standards are subject to the protection by copyright and may not be passed on to third parties by Rexroth. If necessary, please address the authorized sales outlets or, in Germany, directly to:

BEUTH Verlag GmbH

Burggrafenstrasse 6

D-10787 Berlin

Phone +49-(0)30-26 01-22 60, Fax +49-(0)30-26 01-12 60

Internet: <http://www.din.de/beuth>

E-mail: postmaster@beuth.de

Outside Systems

Documentations for external systems, which are connected to Rexroth components, are not included in the scope of delivery and must be ordered directly from the particular manufacturers.

Feedback

Your experiences are an essential part of the process of improving both product and documentation.

Please do not hesitate to inform us of any mistakes you detect in this documentation or of any modifications you might desire. We appreciate your corresponding feedback.

Please send your remarks to:

Bosch Rexroth AG

Dep. BRC/EDM2

Bürgermeister-Dr.-Nebel-Strasse 2

D-97816 Lohr

Telefax +49 (0) 93 52 / 40-43 80

2 Important Instructions on Use

2.1 Intended Use

Introduction

In their design and manufacture, the products by Rexroth reflect the latest state of technology. Before they are delivered, they are checked for their operationally safe state.

The products may only be used as intended. If they are not used as intended, situations may arise resulting in injuries to property and persons.

Note: For damage caused by products not being used as intended, Rexroth, as manufacturers, do not give any warranty, assume any liability, or pay any damages. Any risks resulting from the products not being used as intended are the sole responsibility of the user.

Before using the products by Rexroth, the following requirements must be fulfilled so as to ensure that they are used as intended:

- Anybody handling one of our products in any manner must read and understand the appropriate safety instructions and the intended use.
- If they are hardware components, the products concerned must be left in their original state, i.e. it is not permitted to modify them structurally. Software products may not be decompiled; their source codes may not be altered.
- Damaged or defective products may not be installed or put into operation.
- It must be ensured that the products are installed, operated and serviced according to the regulations and environmental conditions specified in the documentation.

Fields of Use and Application

AC servo motors of the MKD series by Rexroth are intended to be used as servo and main drive motors. The following are typical fields of application:

- Machine tools
- Printing and paper-processing machines
- Packaging and food-processing machines
- Automation and handling

Unit types with different driving powers and different interfaces are available for an application-specific use of the motors.

Controlling and monitoring of the motors may require connection of additional sensors and actuators.

Note: The motors may only be used with the accessories specified in the documentation. Components which are not expressly named may neither be mounted nor connected. The same applies to cables and lines.

The motors may be operated only in the expressly specified component configurations and combinations and with the software and firmware specified in the appropriate functional description.

Any connected drive controller must be programmed before startup, in order to ensure that the motor executes the functions specific to the particular application.

The motors may only be operated under the assembly, mounting and installation conditions, in the position of use, and under the environmental conditions (temperature, degree of protection, humidity, EMC, and the like) specified in this documentation.

2.2 Non-Intended Use

Any use of the motors outside of the fields of application mentioned above or under operating conditions and technical data other than those specified in this documentation is considered to be "non-intended use".

MKD motors may not be used if ...

- they are subjected to operating conditions which do not comply with the environmental conditions described above (e.g. operation under water, under extreme variations in temperature or extreme maximum temperatures is not permitted),
- the intended fields of application have not been expressly released for the motors by Rexroth. Please be absolutely sure to also observe the statements made in the general safety instructions.

3 Safety Instructions for Electric Drives and Controls

3.1 Introduction

Read these instructions before the initial startup of the equipment in order to eliminate the risk of bodily harm or material damage. Follow these safety instructions at all times.

Do not attempt to install or start up this equipment without first reading all documentation provided with the product. Read and understand these safety instructions and all user documentation of the equipment prior to working with the equipment at any time. If you do not have the user documentation for your equipment, contact your local Rexroth Indramat representative to send this documentation immediately to the person or persons responsible for the safe operation of this equipment.

If the equipment is resold, rented or transferred or passed on to others, then these safety instructions must be delivered with the equipment.



WARNING

Improper use of this equipment, failure to follow the safety instructions in this document or tampering with the product, including disabling of safety devices, may result in material damage, bodily harm, electric shock or even death!

3.2 Explanations

The safety instructions describe the following degrees of hazard seriousness in compliance with ANSI Z535. The degree of hazard seriousness informs about the consequences resulting from non-compliance with the safety instructions.

Warning symbol with signal word	Degree of hazard seriousness according to ANSI
 DANGER	Death or severe bodily harm will occur.
 WARNING	Death or severe bodily harm may occur.
 CAUTION	Bodily harm or material damage may occur.

Fig. 3-1: Hazard classification (according to ANSI Z535)

3.3 Hazards by Improper Use



DANGER

**High voltage and high discharge current!
Danger to life or severe bodily harm by electric shock!**



DANGER

Dangerous movements! Danger to life, severe bodily harm or material damage by unintentional motor movements!



WARNING

High electrical voltage due to wrong connections! Danger to life or bodily harm by electric shock!



WARNING

Health hazard for persons with heart pacemakers, metal implants and hearing aids in proximity to electrical equipment!



CAUTION

Surface of machine housing could be extremely hot! Danger of injury! Danger of burns!



CAUTION

Risk of injury due to improper handling! Bodily harm caused by crushing, shearing, cutting and mechanical shock or incorrect handling of pressurized systems!



CAUTION

Risk of injury due to incorrect handling of batteries!

3.4 General Information

- Rexroth Indramat GmbH is not liable for damages resulting from failure to observe the warnings provided in this documentation.
- Read the operating, maintenance and safety instructions in your language before starting up the machine. If you find that you cannot completely understand the documentation for your product, please ask your supplier to clarify.
- Proper and correct transport, storage, assembly and installation as well as care in operation and maintenance are prerequisites for optimal and safe operation of this equipment.
- Only persons who are trained and qualified for the use and operation of the equipment may work on this equipment or within its proximity.
 - The persons are qualified if they have sufficient knowledge of the assembly, installation and operation of the equipment as well as an understanding of all warnings and precautionary measures noted in these instructions.
 - Furthermore, they must be trained, instructed and qualified to switch electrical circuits and equipment on and off in accordance with technical safety regulations, to ground them and to mark them according to the requirements of safe work practices. They must have adequate safety equipment and be trained in first aid.
- Only use spare parts and accessories approved by the manufacturer.
- Follow all safety regulations and requirements for the specific application as practiced in the country of use.
- The equipment is designed for installation in industrial machinery.
- The ambient conditions given in the product documentation must be observed.
- Use only safety features and applications that are clearly and explicitly approved in the Project Planning Manual.
For example, the following areas of use are not permitted: construction cranes, elevators used for people or freight, devices and vehicles to transport people, medical applications, refinery plants, transport of hazardous goods, nuclear applications, applications sensitive to high frequency, mining, food processing, control of protection equipment (also in a machine).
- The information given in the documentation of the product with regard to the use of the delivered components contains only examples of applications and suggestions.
The machine and installation manufacturer must
 - make sure that the delivered components are suited for his individual application and check the information given in this documentation with regard to the use of the components,
 - make sure that his application complies with the applicable safety regulations and standards and carry out the required measures, modifications and complements.
- Startup of the delivered components is only permitted once it is sure that the machine or installation in which they are installed complies with the national regulations, safety specifications and standards of the application.

- Operation is only permitted if the national EMC regulations for the application are met.
The instructions for installation in accordance with EMC requirements can be found in the documentation "EMC in Drive and Control Systems".
The machine or installation manufacturer is responsible for compliance with the limiting values as prescribed in the national regulations.
- Technical data, connections and operational conditions are specified in the product documentation and must be followed at all times.

3.5 Protection Against Contact with Electrical Parts

Note: This section refers to equipment and drive components with voltages above 50 Volts.

Touching live parts with voltages of 50 Volts and more with bare hands or conductive tools or touching ungrounded housings can be dangerous and cause electric shock. In order to operate electrical equipment, certain parts must unavoidably have dangerous voltages applied to them.



DANGER

High electrical voltage! Danger to life, severe bodily harm by electric shock!

- ⇒ Only those trained and qualified to work with or on electrical equipment are permitted to operate, maintain or repair this equipment.
 - ⇒ Follow general construction and safety regulations when working on high voltage installations.
 - ⇒ Before switching on power the ground wire must be permanently connected to all electrical units according to the connection diagram.
 - ⇒ Do not operate electrical equipment at any time, even for brief measurements or tests, if the ground wire is not permanently connected to the points of the components provided for this purpose.
 - ⇒ Before working with electrical parts with voltage higher than 50 V, the equipment must be disconnected from the mains voltage or power supply. Make sure the equipment cannot be switched on again unintended.
 - ⇒ The following should be observed with electrical drive and filter components:
 - ⇒ Wait five (5) minutes after switching off power to allow capacitors to discharge before beginning to work. Measure the voltage on the capacitors before beginning to work to make sure that the equipment is safe to touch.
 - ⇒ Never touch the electrical connection points of a component while power is turned on.
 - ⇒ Install the covers and guards provided with the equipment properly before switching the equipment on. Prevent contact with live parts at any time.
 - ⇒ A residual-current-operated protective device (RCD) must not be used on electric drives! Indirect contact must be prevented by other means, for example, by an overcurrent protective device.
 - ⇒ Electrical components with exposed live parts and uncovered high voltage terminals must be installed in a protective housing, for example, in a control cabinet.
-

To be observed with electrical drive and filter components:



DANGER

**High electrical voltage on the housing!
High leakage current! Danger to life, danger of
injury by electric shock!**

- ⇒ Connect the electrical equipment, the housings of all electrical units and motors permanently with the safety conductor at the ground points before power is switched on. Look at the connection diagram. This is even necessary for brief tests.
- ⇒ Connect the safety conductor of the electrical equipment always permanently and firmly to the supply mains. Leakage current exceeds 3.5 mA in normal operation.
- ⇒ Use a copper conductor with at least 10 mm² cross section over its entire course for this safety conductor connection!
- ⇒ Prior to startups, even for brief tests, always connect the protective conductor or connect with ground wire. Otherwise, high voltages can occur on the housing that lead to electric shock.

3.6 Protection Against Electric Shock by Protective Low Voltage (PELV)

All connections and terminals with voltages between 0 and 50 Volts on Rexroth Indramat products are protective low voltages designed in accordance with international standards on electrical safety.



WARNING

**High electrical voltage due to wrong
connections! Danger to life, bodily harm by
electric shock!**

- ⇒ Only connect equipment, electrical components and cables of the protective low voltage type (PELV = Protective Extra Low Voltage) to all terminals and clamps with voltages of 0 to 50 Volts.
- ⇒ Only electrical circuits may be connected which are safely isolated against high voltage circuits. Safe isolation is achieved, for example, with an isolating transformer, an opto-electronic coupler or when battery-operated.

3.7 Protection Against Dangerous Movements

Dangerous movements can be caused by faulty control of the connected motors. Some common examples are:

- improper or wrong wiring of cable connections
- incorrect operation of the equipment components
- wrong input of parameters before operation
- malfunction of sensors, encoders and monitoring devices
- defective components
- software or firmware errors

Dangerous movements can occur immediately after equipment is switched on or even after an unspecified time of trouble-free operation.

The monitoring in the drive components will normally be sufficient to avoid faulty operation in the connected drives. Regarding personal safety, especially the danger of bodily injury and material damage, this alone cannot be relied upon to ensure complete safety. Until the integrated monitoring functions become effective, it must be assumed in any case that faulty drive movements will occur. The extent of faulty drive movements depends upon the type of control and the state of operation.

**DANGER****Dangerous movements! Danger to life, risk of injury, severe bodily harm or material damage!**

- ⇒ Ensure personal safety by means of qualified and tested higher-level monitoring devices or measures integrated in the installation. Unintended machine motion is possible if monitoring devices are disabled, bypassed or not activated.
- ⇒ Pay attention to unintended machine motion or other malfunction in any mode of operation.

- ⇒ Keep free and clear of the machine's range of motion and moving parts. Possible measures to prevent people from accidentally entering the machine's range of motion:
 - use safety fences
 - use safety guards
 - use protective coverings
 - install light curtains or light barriers
- ⇒ Fences and coverings must be strong enough to resist maximum possible momentum, especially if there is a possibility of loose parts flying off.
- ⇒ Mount the emergency stop switch in the immediate reach of the operator. Verify that the emergency stop works before startup. Don't operate the machine if the emergency stop is not working.
- ⇒ Isolate the drive power connection by means of an emergency stop circuit or use a starting lockout to prevent unintentional start.
- ⇒ Make sure that the drives are brought to a safe standstill before accessing or entering the danger zone. Safe standstill can be achieved by switching off the power supply contactor or by safe mechanical locking of moving parts.
- ⇒ Secure vertical axes against falling or dropping after switching off the motor power by, for example:
 - mechanically securing the vertical axes
 - adding an external braking/ arrester/ clamping mechanism
 - ensuring sufficient equilibration of the vertical axes

The standard equipment motor brake or an external brake controlled directly by the drive controller are not sufficient to guarantee personal safety!

- ⇒ Disconnect electrical power to the equipment using a master switch and secure the switch against reconnection for:
 - maintenance and repair work
 - cleaning of equipment
 - long periods of discontinued equipment use
 - ⇒ Prevent the operation of high-frequency, remote control and radio equipment near electronics circuits and supply leads. If the use of such equipment cannot be avoided, verify the system and the installation for possible malfunctions in all possible positions of normal use before initial startup. If necessary, perform a special electromagnetic compatibility (EMC) test on the installation.
-

3.8 Protection Against Magnetic and Electromagnetic Fields During Operation and Mounting

Magnetic and electromagnetic fields generated near current-carrying conductors and permanent magnets in motors represent a serious health hazard to persons with heart pacemakers, metal implants and hearing aids.



WARNING

Health hazard for persons with heart pacemakers, metal implants and hearing aids in proximity to electrical equipment!

- ⇒ Persons with heart pacemakers, hearing aids and metal implants are not permitted to enter the following areas:
 - Areas in which electrical equipment and parts are mounted, being operated or started up.
 - Areas in which parts of motors with permanent magnets are being stored, operated, repaired or mounted.
 - ⇒ If it is necessary for a person with a heart pacemaker to enter such an area, then a doctor must be consulted prior to doing so. Heart pacemakers that are already implanted or will be implanted in the future, have a considerable variation in their electrical noise immunity. Therefore there are no rules with general validity.
 - ⇒ Persons with hearing aids, metal implants or metal pieces must consult a doctor before they enter the areas described above. Otherwise, health hazards will occur.
-

3.9 Protection Against Contact with Hot Parts



CAUTION

**Housing surfaces could be extremely hot!
Danger of injury! Danger of burns!**

- ⇒ Do not touch housing surfaces near sources of heat! Danger of burns!
- ⇒ After switching the equipment off, wait at least ten (10) minutes to allow it to cool down before touching it.
- ⇒ Do not touch hot parts of the equipment, such as housings with integrated heat sinks and resistors. Danger of burns!



WARNING

Burning via hot surface with temperatures over 100°C

- ⇒ Do not touch the hot motor housing! Risk of burning!
- ⇒ Touch the motor only after cooling! A cooling up to 140 minutes can be necessary! The stated thermal time constant in the technical data is a measure for the necessary cooling time.
- ⇒ Do not work on hot surfaces.
- ⇒ Use safety gloves.

3.10 Protection During Handling and Mounting

Under certain conditions, incorrect handling and mounting of parts and components may cause injuries.



CAUTION

Risk of injury by incorrect handling! Bodily harm caused by crushing, shearing, cutting and mechanical shock!

- ⇒ Observe general installation and safety instructions with regard to handling and mounting.
- ⇒ Use appropriate mounting and transport equipment.
- ⇒ Take precautions to avoid pinching and crushing.
- ⇒ Use only appropriate tools. If specified by the product documentation, special tools must be used.
- ⇒ Use lifting devices and tools correctly and safely.
- ⇒ For safe protection wear appropriate protective clothing, e.g. safety glasses, safety shoes and safety gloves.
- ⇒ Never stand under suspended loads.
- ⇒ Clean up liquids from the floor immediately to prevent slipping.

3.11 Battery Safety

Batteries contain reactive chemicals in a solid housing. Inappropriate handling may result in injuries or material damage.



CAUTION

Risk of injury by incorrect handling!

- ⇒ Do not attempt to reactivate discharged batteries by heating or other methods (danger of explosion and cauterization).
- ⇒ Never charge non-chargeable batteries (danger of leakage and explosion).
- ⇒ Never throw batteries into a fire.
- ⇒ Do not dismantle batteries.
- ⇒ Do not damage electrical components installed in the equipment.

Note: Be aware of environmental protection and disposal! The batteries contained in the product should be considered as hazardous material for land, air and sea transport in the sense of the legal requirements (danger of explosion). Dispose batteries separately from other waste. Observe the legal requirements in the country of installation.

3.12 Protection Against Pressurized Systems

Certain motors and drive controllers, corresponding to the information in the respective Project Planning Manual, must be provided with pressurized media, such as compressed air, hydraulic oil, cooling fluid and cooling lubricant supplied by external systems. Incorrect handling of the supply and connections of pressurized systems can lead to injuries or accidents. In these cases, improper handling of external supply systems, supply lines or connections can cause injuries or material damage.



CAUTION

Danger of injury by incorrect handling of pressurized systems !

- ⇒ Do not attempt to disassemble, to open or to cut a pressurized system (danger of explosion).
- ⇒ Observe the operation instructions of the respective manufacturer.
- ⇒ Before disassembling pressurized systems, release pressure and drain off the fluid or gas.
- ⇒ Use suitable protective clothing (for example safety glasses, safety shoes and safety gloves)
- ⇒ Remove any fluid that has leaked out onto the floor immediately.

Note: Environmental protection and disposal! The media used in the operation of the pressurized system equipment may not be environmentally compatible. Media that are damaging the environment must be disposed separately from normal waste. Observe the legal requirements in the country of installation.

Notes

4 MKD Type Code

Each order of a product by Rexroth must be based on the type code. All available motor versions are uniquely described by their type code. In the following, the particular points of the type code (abbrev. column) and their meaning are described.

Abbrev. Column	1	2	3	4	5	6	7	8	9	0	1	2	3	4	5	6	7	8	9	0	1	2	3	4	5	6	7	8	9	0	1	2	3	4	5	6	7	8	9	0	
Example:	M	K	D	1	1	2	B	-	0	4	8	-	G	G	0	-	A	N																							

1.	Product	
1.1	MKD = MKD	
2.	Motor size	
2.1	112 = 112	
3.	Motor length	
3.1	Lengths = A, B, C, D	
4.	Windings code	
4.1	MKD112A = 024, 058	
4.2	MKD112B = 024, 048, 058	
4.3	MKD112C = 024, 058	
4.4	MKD112D = 027	
5.	Motor feedback	
5.1	Resolver feedback = G	
5.2	Resolver feedback with integrated multiturn absolute encoder = K	
6.	Driven shaft	
6.1	plain shaft (with shaft sealing ring) = G	
6.2	Shaft with key per DIN 6885-1 (with shaft sealing ring) = P	
7.	Holding brake ①	
7.1	without holding brake = 0	
7.2	with holding brake 22 Nm = 1	
7.3	with holding brake 70 Nm = 3	
8.	Output direction of power connection	
8.1	Connector to side A = A	
8.2	Connector to side B = B	
8.3	Connector to the left = L	
8.4	Connector to the right = R	
9.	Other design	
9.1	none = N	
10.	Standard reference	
	Standard Title Edition	
	DIN 6885-1 Drive Type Fastenings without Taper Action; 1968-08	
	Parallel Keys, Keyways, Deep Pattern	

Note:

- ① Holding brake "1" only available with motor length "A" and "B"
- Holding brake "3" only available with motor length "C" and "D"
- ② Looking from front onto driven shaft (see picture 1)

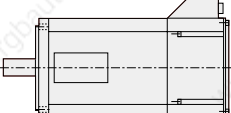
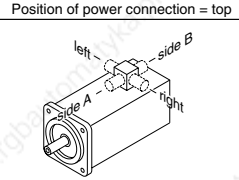

Illustration example: MKD112



Position of power connection = top

Picture 1

typecode_example.th7

Fig. 4-1: MKD type code (example)

Note: When selecting a product, always consider the detailed specifications and instructions in the chapters entitled “Technical Data” and “Application Instructions”.

- The sections below are numbered according to the numbering of the individual type codes (see chapter “Technical Data”).
- Before ordering, please check the availability of the separate options with your Bosch Rexroth Sales & Service Facilities.

1. Product Group

Abbrev. column 1 2 3

MKD Three-digit Rexroth-Indramat-specific designation of a servo motors series.

2. Motor Frame Size

Abbrev. column 4 5 6

The motor frame size defines essential mechanical motor dimensions. The following table assigns essential motor dimensions to the motor frame sizes.

Motor frame size	Description / details	
	Flange size in mm	Centering diameter in mm
025	54	40
041	82	50
071	115	95
090	140	110
112	192	130

Fig. 4-2: MKD motor frame sizes

3. Motor Frame Length

Abbrev. column 7

Within the scope of a motor frame size, the motor frame length defines the various continuous torques at standstill. The continuous torques at standstill of the MKD motors are listed in the table below. The values specified are applicable to the "natural convection" mode.

Motor frame length	Motor frame size				
	025	041	071	090	112
A	0.4 Nm	1.3 Nm	3.5 Nm	--	15.0 Nm
B	0.9 Nm	2.7 Nm	8.0 Nm	12.0 Nm	28.0 Nm
C	--	--	--	--	38.0 Nm
D	--	--	--	--	48.0 Nm

Fig. 4-3: MKD motor frame lengths

4. Winding Code

Abbrev. column 9 10 11

In connection with the motor frame size and motor frame length, the winding codes define the electric motor output data for all Rexroth Indramat motors.

The type code specifies all possible winding codes, which are available for a motor frame size / length.

Motor frame size / length	Available winding codes
MKD112B	024, 035, 048, 058

Fig. 4-4: Winding code example

5. Motor feedback

Abbrev. column **13**

MKD motors are equipped with an integrated encoder system (motor feedback). To control the motor speed and/or to position the motor, the drive controller requires information on the current motor position.

To achieve this, the integrated encoder system (motor feedback) makes the appropriate signals available to the drive controller.

The following options are available:

Option	Type	Type of position detection
N	Resolver-feedback (RSF)	Relative
P	Resolver feedback (RSF with integrated multiturn absolute encoder)	Absolute (more than 4096 revolutions)

Fig. 4-5: MKD motor encoder

6. Output Shaft

Abbrev. column **14**

To connect the machine elements to be driven to the motor shafts, the following options are available for MKD motors.

Option	Design	Detail
G	Plain shaft	With end-sided centering hole with "DS" thread according to DIN 332, Part 2, Edition 05.83
P	Shaft with keyway ¹⁾	
1) Keyway according to DIN 6885, Sheet 1, ed. 08.68. For details, refer to the motor rating sheet!		

Fig. 4-6: MKD output shafts

Note: MKD motors are balanced with the **complete** featherkey. The pertinent featherkey is not included in the scope of delivery.

7. Holding Brake

Abbrev. column **15**

Optional. Required for clamping the servo axis when the machine is in the de-energized state.

Option	Holding Brakes	
0	Without holding brake	
1, 3	With holding brake	Please refer to the motor type codes for the holding torques.

Fig. 4-7: MKD holding brakes

The holding brake is operated according to the "electrically releasing" principle. In the de-energized state, a magnetic force acts upon the brake armature disk. This causes the brake to close and to hold the axis.

By applying 24 VDC ($\pm 10\%$), the permanent magnetic field is compensated by the electrically generated magnetic field: the brake opens.

Note: Please also observe the installation and safety instructions on the motor holding brakes in the chapter entitled "Application Instructions".

8. Output Direction of Power Connector

Abbrev. column 17

The possible cable output directions for Rexroth Indramat motors are defined as follows. The following is applicable (view on the output shaft):

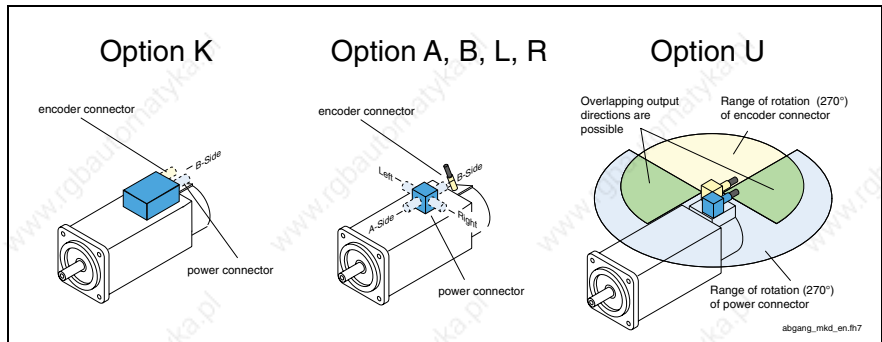

Fig. 4-8: Definition of cable output directions

Option	Output direction	Available for the motors below
K	connection box	MKD025 MKD041 MKD071 MKD090
U	Power and encoder connectors turnable within a range of 270°	MKD025
A	Output connector in direction of side A	MKD112
B	Output connector in direction of side B	
L	Power connector to the left	
R	Power connector to the right	

Fig. 4-9: MKD cable output directions

MKD motors are delivered according to the option specified in the order.

Note: The cable output direction can be changed during assembly (see Chapter 18).

9. Other performances

Abbrev. column 18

N = standard performance

10. Reference to Standards

The item "reference to standards" indicates standards referred to in the type code (e.g. DIN, EN, ISO, etc.) or also applicable factory standards (INN . . .). The version listed is always that valid at the time of type code issuing.

Remark

Please refer to this item for additionally required information concerning the handling of the type code. This includes, e.g, descriptions on footnotes, notes on availability, or exclusion clauses.

5 General Notes on Technical Data

5.1 60K and 100K Parameters

The speed-torque curves and the technical data are specified for two different motor overtemperatures.

These are:

- 60K housing overtemperature
- 100K winding overtemperature

Note: When selecting the technical data, observe the temperatures specified! The appropriate parameters are identified by **100K** or **60K**.

Structure and measurement of the 60K characteristic curve

The motor data and characteristic curves are determined using MKD motors under the following conditions:

- Environmental temperature approx. 45 °C
- Insulated structure (aluminum flange)
- Permissible housing overtemperature $\Delta T = 60K$
- If motors with the optional holding brake are concerned, the data are always specified for motors **with** holding brake.
- Motors with radial shaft sealing ring

Structure and measurement of the 100K characteristic curve

The motor data and characteristic curves are determined using MKD motors under the following conditions:

- Environmental temperature approx. 40°C
- Structure **not** insulated (attachment to steel flange, LxWxH 450x30x350 in size; LxWxH 120x40x100 in case of the MKD041)
- Permissible winding overtemperature $\Delta T = 100K$
- If motors with the optional holding brake are concerned, the data are always specified for motors **with** holding brake.
- Motors with radial shaft sealing ring

Note: The machine accuracy can be negatively affected by an increased linear expansion during 100K operation. We recommend to use 60K data when projecting systems.

5.2 Operating Modes

Rexroth motors are documented according to the test criteria and measuring methods of EN 60034-1. The characteristic curves specified correspond to the operating modes S1 or S6.

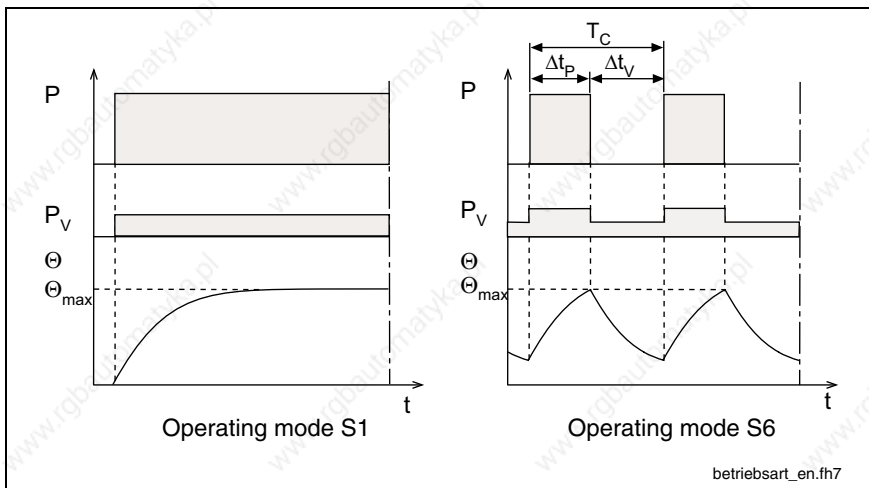

P: Load
 P_V: Electric losses
 Θ: Temperature
 Θ_{max}: Highest temperature (motor housing)
 t: Time
 T_C: Cycle duration
 Δt_P: Operating time with constant load
 Δt_V: Idle time

Fig. 5-1: Operating modes according to EN 60034-1: 1998

ON time

The operating mode S6 is supplemented by specification of the ON time (ED) in %. The ON time is calculated with the following formula:

$$ED = \frac{\Delta t_P}{T_C} \cdot 100\%$$

ED: Cyclic duration factor in %
 T_C: Cycle duration
 Δt_P: Operating time with constant load

Fig. 5-2: Cyclic duration factor

The values specified in the documentation have been determined on the basis of the following parameters:

Cycle duration: 15 min (MKD041, -071, -090, -112)
 10 min (MKD025)
 Cyclic duration factor (ED): 25%

Note: If applicable, conditions deviating therefrom are marked accordingly.

5.3 Definition of Parameters

Electric parameters

Characteristic motor speed n_K	With a DC link voltage of 540 V _{DC} and at the characteristic speed, the continuous torque that can be output is approx. ½ continuous torque at standstill.
Continuous torque at standstill M_{dN}	The continuous torque that can be output at the motor output shaft at a speed of $n = 0$.
Continuous current at standstill I_{dN}	Phase current (crest value) of the motor required for the continuous torque at standstill M_{dN} at a speed of $n = 0$.
Peak current I_{max}	Maximum, briefly permissible phase current (crest value) of the motor without adverse affect on the permanent magnet circuit of the motor.
Torque constant at 20 °C K_M	Ratio of the increase in torque to the motor phase current (crest value) at a motor temperature of 20 °C. Unit: (Nm/A). Applicable up to approx. $I = 2 \times I_{dN}$.
Voltage constant at 20 °C $K_{E(eff)}$	Root-mean-square value of the induced motor voltage at a motor temperature of 20 °C and 1000 revolutions per minute. Unit: (V/1000 min ⁻¹).
Winding resistance at 20 °C R_{12}	Winding resistance measured between two phases in ohms (Ω).
Winding inductivity L_{12}	Inductivity measured between two phases in (mH).
Number of pole pairs p	Number of pole pairs of the motor.
Rated speed n_N	Typical useful speed defined by the manufacturer. Depending on the particular application, other useful speeds are possible (see speed-torque-curve).
Rated torque M_N	Continuous torque that can be output at the rated speed in operating mode S1.
Rated current $I_{N(eff)}$	Phase current of the motor at the rated speed and load with rated torque, specified as root-mean-square value.
Rated output P_N	Power consumption of the motor at the rated speed and load with rated torque, specified in kilowatts (kW).
Rated voltage $U_{N(eff)}$	Root-mean-square value of the voltage to be applied to the motor, with the motor loaded with the rated torque and the rated speed. Unit (V).
Rated frequency f_N	Frequency of the rated voltage at rated speed (Hz).

Mechanical parameters

Maximum speed n_{\max}

Maximum permissible speed of the motor. Limiting factors can have mechanical (centrifugal forces, bearing stress) or electrical (DC link voltage) causes.

Theoretical maximum torque M_{\max}

Maximum torque that can be output for approx. 400 ms at a peak current of I_{\max} (guaranteed value which, owing to production tolerances, may be higher by 20%). The achievable maximum torque depends on the drive controller used. Only the maximum torque M_{\max} specified in the selection lists for the motor-controller combination are binding.

Moment of inertia of the rotor J_M

Moment of inertia of the rotor without the optional holding brake. Unit (kgm^2).

Mass m_M

Motor mass without the optional holding brake and optional motor blower, specified in kg.

Thermal time constant T_{th}

Time of the temperature rise to 63% of the final temperature of the motor housing with the motor loaded with the permissible S1 continuous torque. The thermal time constant is destined for the size of the motors and the used method of cooling.

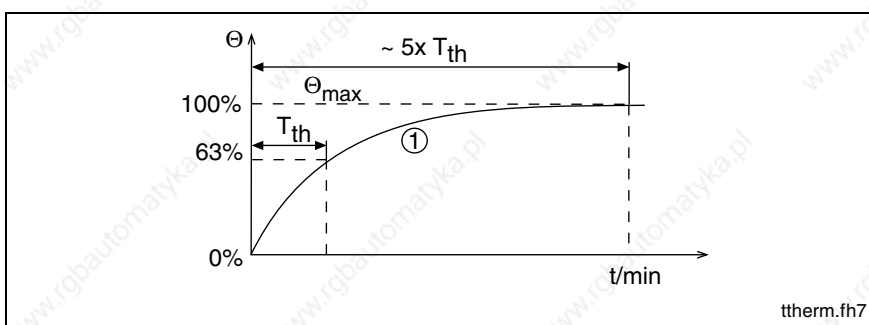

(1): Course of the motor housing temperature over time

Θ_{\max} : Highest temperature (motor housing)

T_{th} : Thermal time constant

Fig. 5-3: Thermal time constant

5.4 Sample Curve

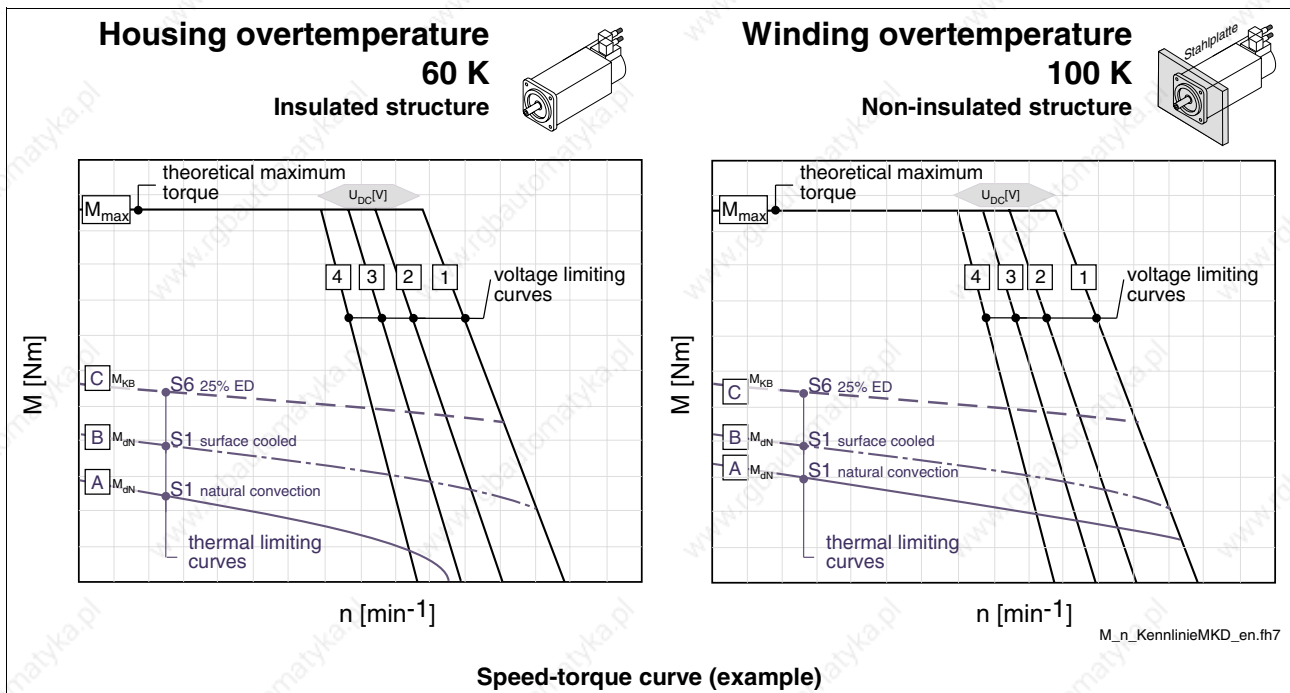

Speed-torque curve (example)

[A]-[C]: **Thermal limit curves**

- [A]: M_{dN} S1 continuous operation curve of the motor (according to EN 60034-1; 1998), natural convection
- [B]: M_{dN} S1 continuous operation curve of the motor (according to EN 60034-1; 1998), surface cooling
- [C]: M_{KB} S6 intermittent operation curve with a motor ON time of 25% (according to EN 60034-1; 1998). The maximum cycle duration is 15 min.

[M_{max}]: Corresponds to the theoretically possible maximum torque of the motor. The value can be limited by the drive controller.

[1]-[4]: **Characteristic voltage limit curves.** When a speed at the safe commutation limit is reached, the voltage limit curve limits the available maximum torque M_{max} . The maximum motor speed is determined by the DC link voltage used. There are separate characteristic curves for the various drive controllers in connection with the power supply unit and the supply voltage used.

- [1]: HDS to HVR
- [2]: HDS to HVE or DKCxx.3 with a power connection of 3 x AC 480 V
- [3]: HDS to HVE or DKCxx.3 with a power connection of 3 x AC 440 V
- [4]: HDS to HVE or DKCxx.3 with a power connection of 3 x AC 400 V

Fig. 5-4: Sample curves

6 MKD025

6.1 Technical Data

Description	Symbol	Unit	MKD025A-144		
			Natural 60K	Natural 100K	Surface 60K /100K
Cooling mode – Motor overtemperature			Natural 60K	Natural 100K	Surface 60K /100K
Electric parameters					
Characteristic motor speed	n_K	min^{-1}	9000		
Continuous torque at standstill	M_{dN}	Nm	0,4	0,45	---
Continuous current at standstill	I_{dN}	A	2,2	2,5	---
Peak current	I_{max}	A	10,0		
Torque constant at 20°C ¹⁾	K_m	Nm/A	0,2		
Voltage constant at 20°C	$K_{E(eff)}$	V/1000min ⁻¹	18,2		
Winding resistance at 20°C	R_{12}	Ω	7,3		
Winding inductance	L_{12}	mH	8,1		
Number of pole pairs	p		3		
Rated data ²⁾					
Rated speed	n_N	min^{-1}	5000	5000	---
Rated torque	M_N	Nm	0,18	0,39	---
Rated current	I_N	A	0,7	1,5	---
Rated power	P_N	kW	0,12	0,27	---
Rated voltage	U_N	V	97	104	---
Rated frequency	f_N	Hz	250	250	---
Mechanical parameters					
Rotor inertia	J_M	kgm^2	0,2 (0,3) ⁸⁾ x 10 ⁻⁴		
Theoretical maximum torque	M_{max}	Nm	1,8		
Minimum strand cross-section ⁴⁾	S	mm^2	1	1	---
Thermal time constant	T_{th}	min	15	15	---
Maximum speed	n_{max}	min^{-1}	9000		
Motor mass ^{3) 5)}	m	kg	1,5		
Perm. storage and transport temp.	T_L	°C	-20 to +80		
Permissible ambient temperature ⁶⁾	T_{um}	°C	0 to 40		
Max. setup height ⁶⁾	h	m	1000 above NN		
Protection category ⁷⁾			IP65		
Insulation class (according to DIN VDE 0530 Part 1)			F		
Housing coat			Prime coat black in a/w RAL 9005		
¹⁾ K_m is to be used for calculations with crest values (I_{dN} , I_{max}). For calculations with root-mean-square values (rated data), the torque constant K_m must be multiplied by a factor of $\sqrt{2}$. ²⁾ Values determined according to EN 60034-1. Current and voltage specified as root-mean-square values. ³⁾ Without holding brake. ⁴⁾ Applicable to REXROTH cables. Rated according to VDE0298-4 (1992) and installation type B2 according to EN 60204-1 (1993) at an ambient temperature of 40 °C. ⁵⁾ Without blower unit. ⁶⁾ If the limits specified are exceeded, the performance data must be reduced if necessary. For reduction factors, refer to the chapter entitled "Environmental Conditions". ⁷⁾ Provided the power and encoder cables are mounted properly ⁸⁾ Use the declared value in bracket for motors with encoder type "K".					

Fig. 6-1: Technical Data MKD025A

Description	Symbol	Unit	MKD025B-058		
			Natural 60K	Natural 100K	Surface 60K /100K
Cooling mode – Motor overtemperature			Natural 60K	Natural 100K	Surface 60K /100K
Electric parameters					
Characteristic motor speed	n_K	min^{-1}	9000		
Continuous torque at standstill	M_{dN}	Nm	0,9 (0,8)	1,0 (0,9)	---
Continuous current at standstill	I_{dN}	A	2,3 (2,0)	2,6 (2,3)	---
Peak current	I_{max}	A	10,4		
Torque constant at 20°C ¹⁾	K_m	Nm/A	0,43		
Voltage constant at 20°C	$K_{E(\text{eff})}$	V/1000min ⁻¹	37,1		
Winding resistance at 20°C	R_{12}	Ω	10,3		
Winding inductance	L_{12}	mH	14,4		
Number of pole pairs	p		3		
Rated data ²⁾					
Rated speed	n_N	min^{-1}	5000	5000	---
Rated torque	M_N	Nm	0,52	0,7	---
Rated current	I_N	A	0,94	1,3	---
Rated power	P_N	kW	0,32	0,44	---
Rated voltage	U_N	V	196	200	---
Rated frequency	f_N	Hz	250	250	---
Mechanical parameters					
Rotor inertia	J_M	kgm^2	$0,3 \times 10^{-4}$		
Theoretical maximum torque	M_{max}	Nm	4,0		
Minimum strand cross-section ⁴⁾	S	mm^2	1,0	1,0	---
Thermal time constant	T_{th}	min	15	15	---
Maximum speed	n_{max}	min^{-1}	9000		
Motor mass ^{3) 5)}	m	kg	1,5		
Perm. storage and transport temp.	T_L	°C	-20 to +80		
Permissible ambient temperature ⁶⁾	T_{um}	°C	0 to 40		
Max. setup height ⁶⁾	h	m	1000 above NN		
Protection category ⁷⁾			IP65		
Insulation class (according to DIN VDE 0530 Part 1)			F		
Housing coat			Prime coat black in a/w RAL 9005		
¹⁾ K_m is to be used for calculations with crest values (I_{dN} , I_{max}). For calculations with root-mean-square values (rated data), the torque constant K_m must be multiplied by a factor of $\sqrt{2}$. ²⁾ Values determined according to EN 60034-1. Current and voltage specified as root-mean-square values. ³⁾ Without holding brake. ⁴⁾ Applicable to REXROTH cables. Rated according to VDE0298-4 (1992) and installation type B2 according to EN 60204-1 (1993) at an ambient temperature of 40 °C. ⁵⁾ Without blower unit. ⁶⁾ If the limits specified are exceeded, the performance data must be reduced if necessary. For reduction factors, refer to the chapter entitled "Environmental Conditions". ⁷⁾ Provided the power and encoder cables are mounted properly. ⁸⁾ Use the declared value in bracket for motors with encoder type "K".					

Fig. 6-2: Technical Data MKD025B-058

Description	Symbol	Unit	MKD025B-144		
Cooling mode – Motor overtemperature			Natural 60K	Natural 100K	Surface 60K /100K
Electric parameters					
Characteristic motor speed	n_K	min^{-1}	9000		
Continuous torque at standstill	M_{dN}	Nm	0,9 (0,8)	1,0 (0,9)	---
Continuous current at standstill	I_{dN}	A	5,1(4,5)	5,7 (5,1)	---
Peak current	I_{max}	A	23,0		
Torque constant at 20°C ¹⁾	K_m	Nm/A	0,2		
Voltage constant at 20°C	$K_{E(\text{eff})}$	V/1000min ⁻¹	18,2		
Winding resistance at 20°C	R_{12}	Ω	2,7		
Winding inductance	L_{12}	mH	3,7		
Number of pole pairs	p		3		
Rated data ²⁾					
Rated speed	n_N	min^{-1}	5000	5000	---
Rated torque	M_N	Nm	0,31 (0,28)	0,59 (0,53)	---
Rated current	I_N	A	1,2 (1,1)	2,4 (2,1)	---
Rated power	P_N	kW	0,2 (0,18)	0,4 (0,36)	---
Rated voltage	U_N	V	94,7 (94,3)	98,4 (97,5)	---
Rated frequency	f_N	Hz	250	250	---
Mechanical parameters					
Rotor inertia	J_M	kgm^2	$0,3 \times 10^{-4}$		
Theoretical maximum torque	M_{max}	Nm	4		
Minimum strand cross-section ⁴⁾	S	mm^2	1	1	---
Thermal time constant	T_{th}	min	15	15	---
Maximum speed	n_{max}	min^{-1}	9000		
Motor mass ^{3) 5)}	m	kg	2,0 (2,3)		
Perm. storage and transport temp.	T_L	°C	-20 to +80		
Permissible ambient temperature ⁶⁾	T_{um}	°C	0 to 40		
Max. setup height ⁶⁾	h	m	1000 above NN		
Protection category ⁷⁾			IP65		
Insulation class (according to DIN VDE 0530 Part 1)			F		
Housing coat			Prime coat black in a/w RAL 9005		
¹⁾ K_m is to be used for calculations with crest values (I_{dN} , I_{max}). For calculations with root-mean-square values (rated data), the torque constant K_m must be multiplied by a factor of $\sqrt{2}$. ²⁾ Values determined according to EN 60034-1. Current and voltage specified as root-mean-square values. ³⁾ Use the declared value in bracket for motors holding brake. ⁴⁾ Applicable to REXROTH cables. Rated according to VDE0298-4 (1992) and installation type B2 according to EN 60204-1 (1993) at an ambient temperature of 40 °C. ⁵⁾ Without blower unit. ⁶⁾ If the limits specified are exceeded, the performance data must be reduced if necessary. For reduction factors, refer to the chapter entitled "Environmental Conditions". ⁷⁾ Provided the power and encoder cables are mounted properly					

Fig. 6-3: Technical Data MKD025B

Holding brake

Description	Symbol	Unit	Holding brake data
Holding torque	M_4	Nm	1,0
Rated voltage (+/- 10%)	U_N	V	24
Rated current	I_N	A	0,4
Moment of inertia	J_B	kgm ²	$0,08 \times 10^{-4}$
Clamping delay	t_1	ms	3
Release delay	t_2	ms	4
Mass	m_B	kg	0,25

Fig. 6-4: Technical data MKD025 holding brake (Option)

6.2 Type code – Ordering type

Abbrev. Column	1	2	3	4	5	6	7	8	9	0	1	2	3	4	5	6	7	8	9	0	1	2	3	4	5	6	7	8	9	0						
Example:	M	K	D	0	2	5	A	-	1	4	4	-	G	G	0	-	K	N																		

1. Product

1.1 MKD = MKD

2. Motor size

2.1 025 = 025

3. Motor length

3.1 Lengths = A, B

4. Windings code

4.1 MKD025A = 144

4.2 MKD025B = 058, 144

5. Motor encoder

5.1 Resolver feedback = G

5.2 Resolver feedback with integrated multiturn absolute encoder = K

6. Driven shaft

6.1 plain shaft (with shaft sealing ring) = G

6.2 Shaft with key per DIN 6885-Page 1 (with shaft sealing ring) = P

7. Holding brake

7.1 without holding brake = 0

7.2 with holding brake 1 Nm = 1①

8. Output direction of power connection ②

8.1 Terminal box (delivering: to side B) = K

8.2 Connector turnable 270° = U

9. Housing design

9.1 standard = N

9.2 Ex type for cluster II, category 3, G and D on DIN EN 50021 = S

10. Standard reference

Standard	Title	Edition
DIN 6885-1	Drive Type with Fastenings without Taper Action; Parallel Keys, Keyways, Deep Pattern	1968-08
DIN EN 50021	Electrical apparatus for potentially explosive atmospheres, Type of protection "n"	2000-02

Note:

①olding brake "1" only available with motor length "B"

②ooking from front onto driven shaft (see illustration example)

Illustration example: Output direction of power connection

"Connector turnable 270°"

"Junction box"

Fig. 6-5: MKD025 type code

6.3 Speed – Torque – Characteristics

**Housing overtemperature
60K**
Insulated structure

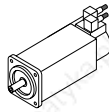

**Windings overtemperature
100K**
Non insulated structure

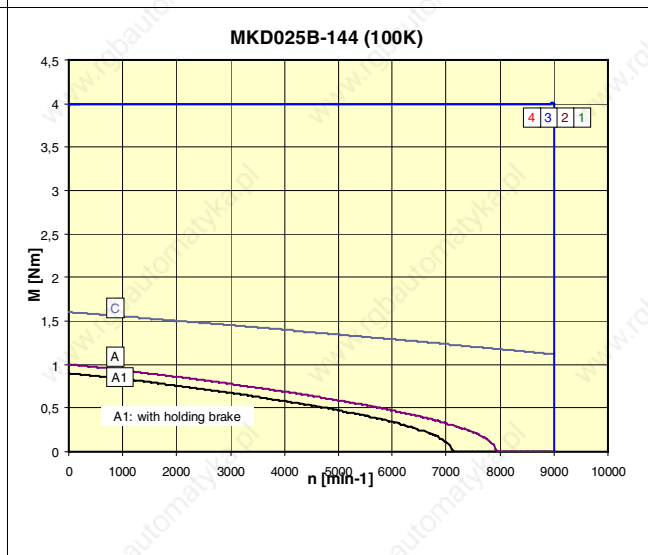
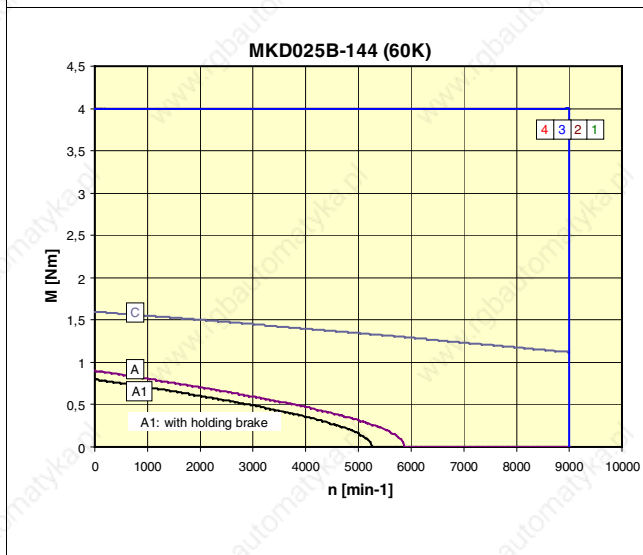
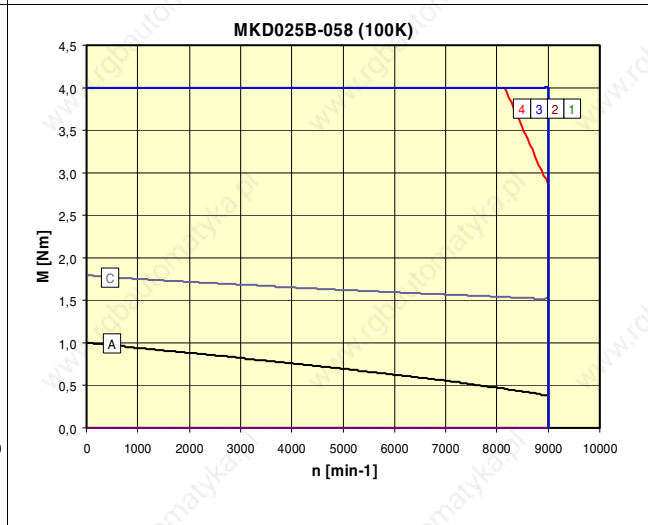
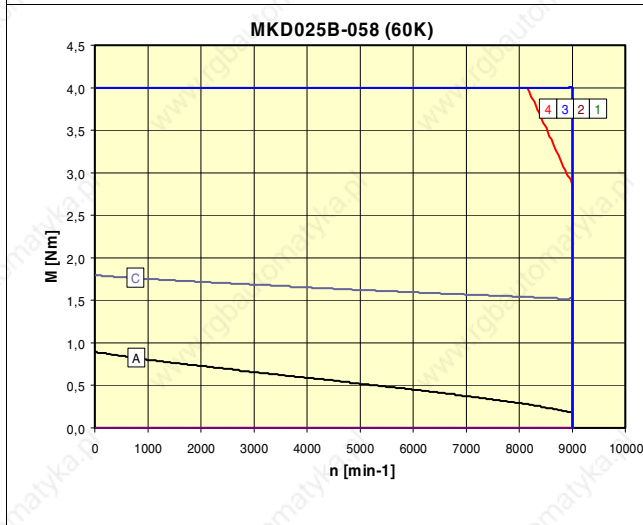
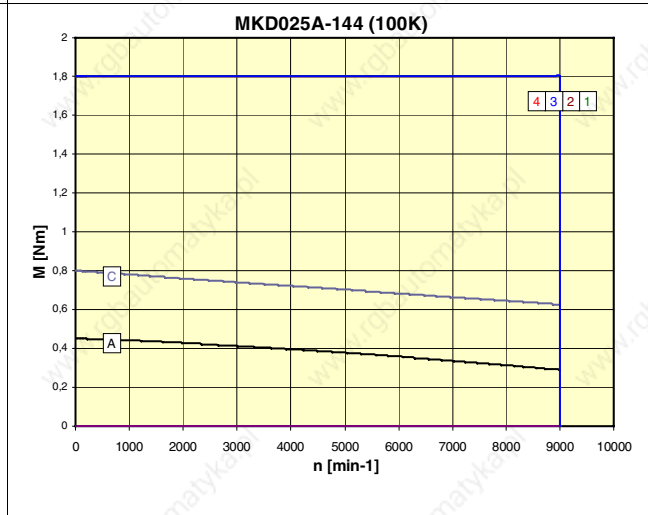
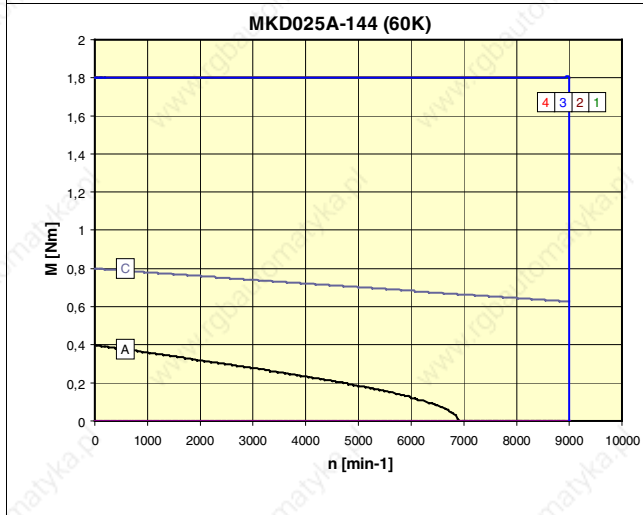
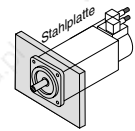

- [A]: M_{dN} Natural conv. (S1 continuous operation)
- [A1]: M_{dN} Natural conv. (S1 continuous operation), Motor with holding brake
- [C]: M_{kB} (S6 intermittent operation)
- [1]: HDS to HVR
- [2]: HDS to HVE or DKCxx.3 with a power connection of 3x AC 480V
- [3]: HDS to HVE or DKCxx.3 with a power connection of 3x AC 440V
- [4]: HDS to HVE or DKCxx.3 with a power connection of 3x AC 400V

Fig. 6-6: Speed torque characteristics

6.4 Shaft Load

Permissible maximum radial force $F_{\text{radial_max}}$ and permissible radial force F_{radial}

For explanations refer to page 13-12.

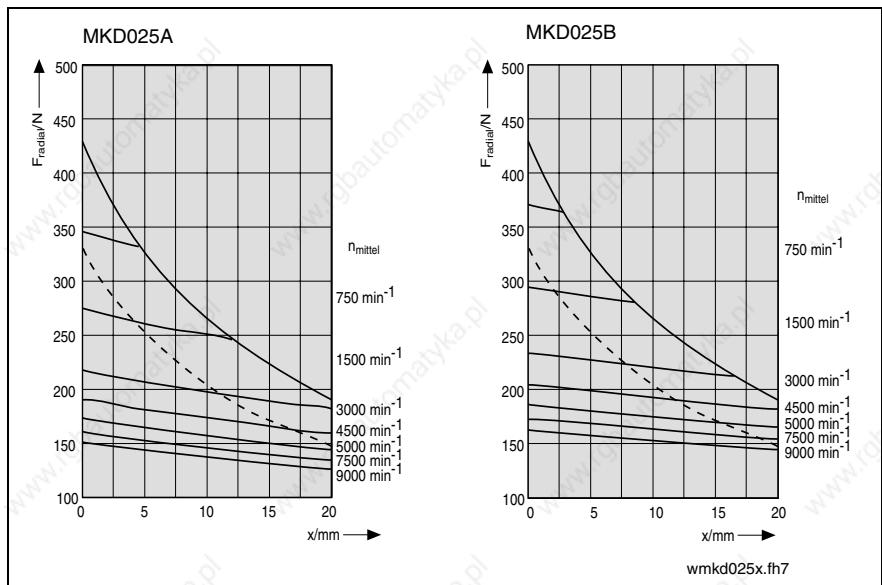

- (1): $F_{\text{radial_max}}$ (plain shaft)
- (2): $F_{\text{radial_max}}$ (shaft with keyway)

Fig. 6-7: MKD025: Permissible maximum radial force $F_{\text{radial_max}}$ and permissible radial force F_{radial}

Permissible axial force F_{axial}

$$F_{\text{axial}} = x \cdot F_{\text{radial}}$$

- x: 0,59 für MKD025A
- 0,55 für MKD025B

F_{axial} : permissible axial force in N
 F_{radial} : permissible radial force in N

Fig. 6-8: MKD025: permissible axial force F_{axial}

6.5 Dimensions

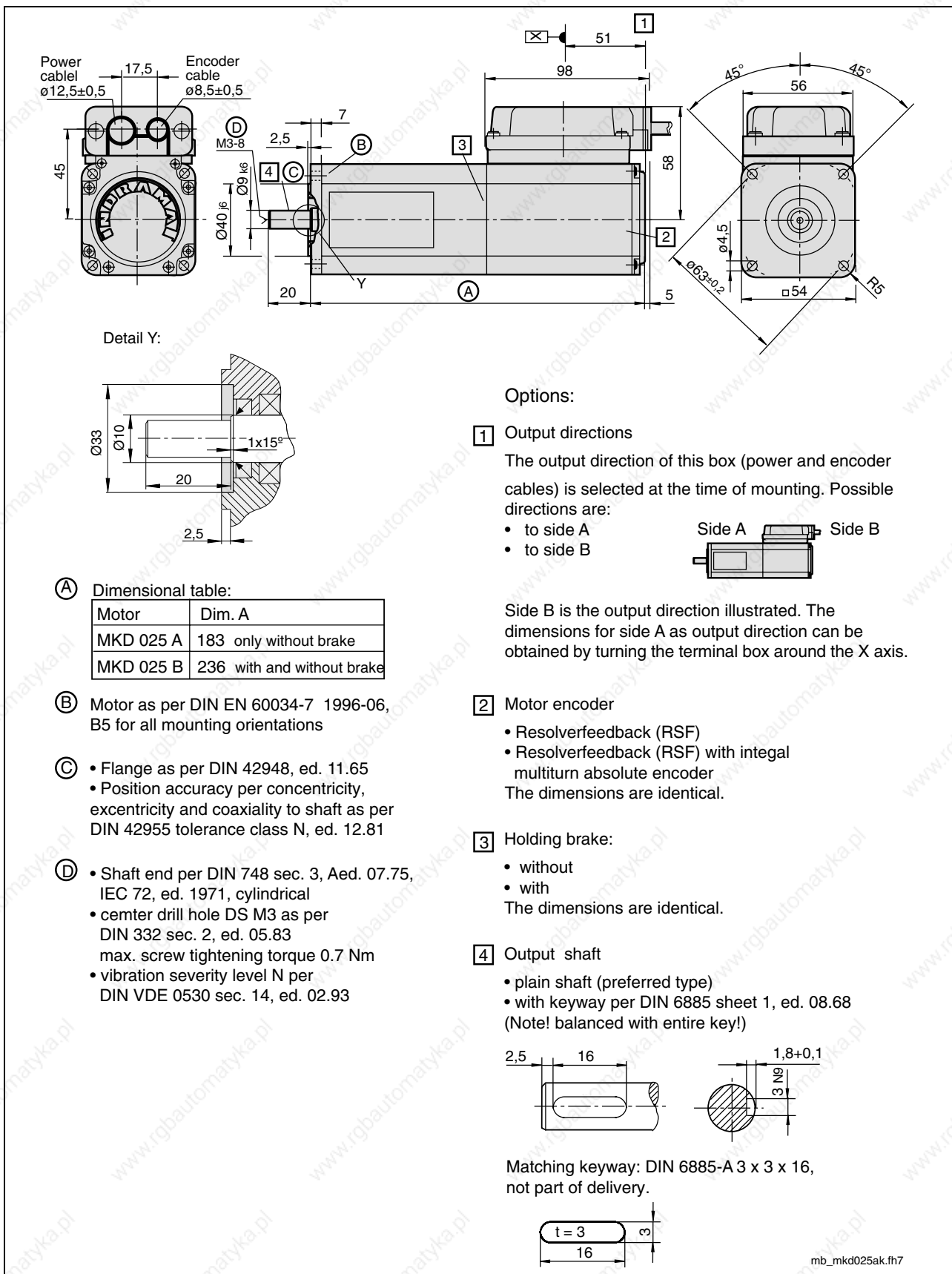

Fig. 6-9: Dimensional data MKD025A;-B (with terminal box)

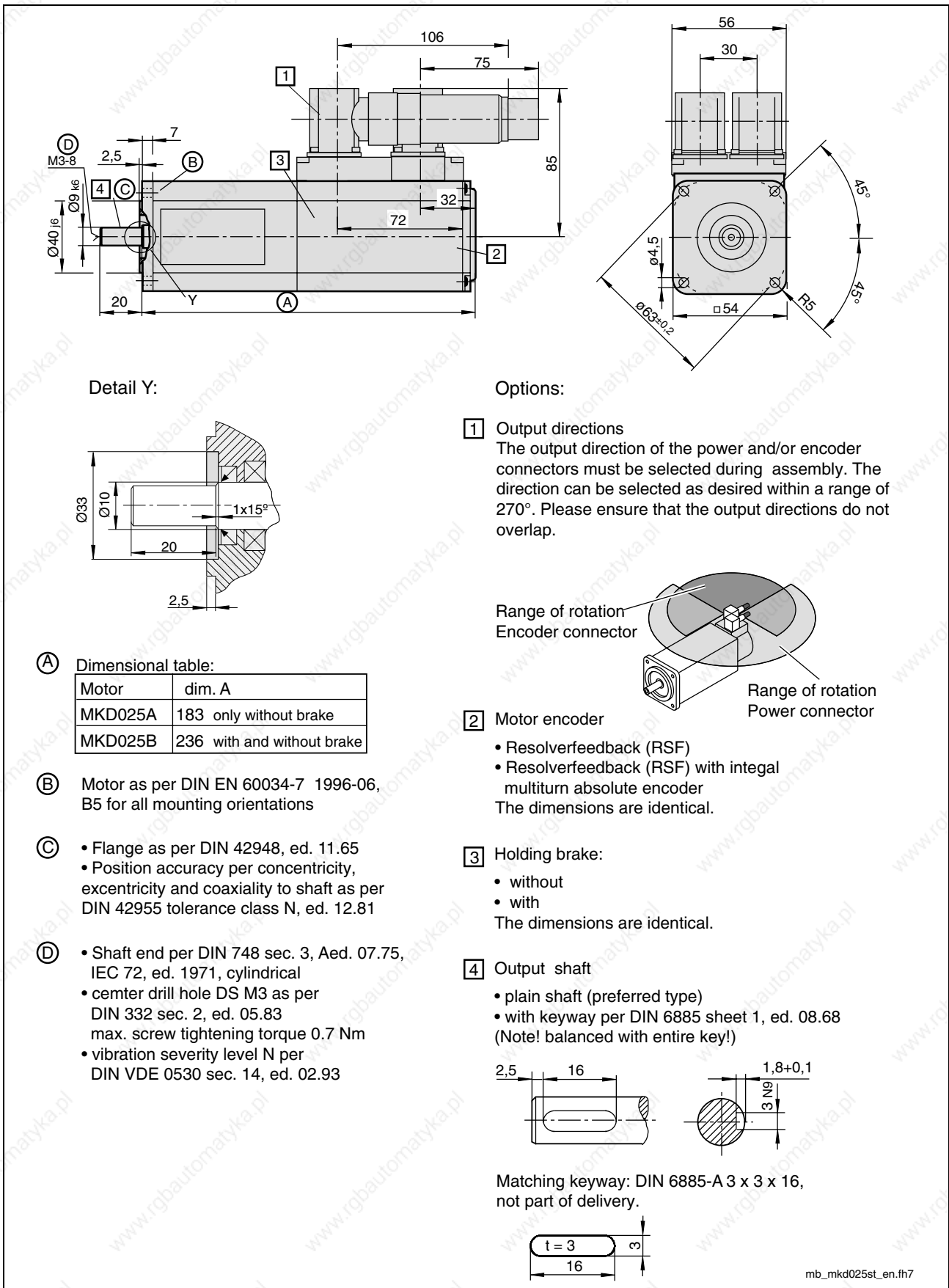

Fig. 6-10: Dimensional data MKD025A;-B (with plug in connection)

7 MKD041

7.1 Technical Data

Description	Symbol	Unit	MKD041B-058		
			Natural 60K	Natural 100K	Surface 60K /100K
Cooling mode – Motor overtemperature			Natural 60K	Natural 100K	Surface 60K /100K
Electric parameters					
Characteristic motor speed	n_K	min^{-1}	6000		
Continuous torque at standstill	M_{dN}	Nm	2,7	2,9	---
Continuous current at standstill	I_{dN}	A	3,4	3,8	---
Peak current	I_{max}	A	15,3		
Torque constant at 20°C ¹⁾	K_m	Nm/A	0,87		
Voltage constant at 20°C	$K_{E(eff)}$	V/1000min ⁻¹	75,8		
Winding resistance at 20°C	R_{12}	Ω	6,8		
Winding inductance	L_{12}	mH	19,0		
Number of pole pairs	p		3		
Rated data ²⁾					
Rated speed	n_N	min^{-1}	5000	5000	---
Rated torque	M_N	Nm	0,96	1,71	---
Rated current	I_N	A	0,85	1,58	---
Rated power	P_N	kW	0,6	1,1	---
Rated voltage	U_N	V	386	393	---
Rated frequency	f_N	Hz	250	250	---
Mechanical parameters					
Rotor inertia	J_M	kgm^2	$1,7 \times 10^{-4}$		
Theoretical maximum torque	M_{max}	Nm	11,3		
Minimum strand cross-section ⁴⁾	S	mm^2	1	1	---
Thermal time constant	T_{th}	min	30	30	---
Maximum speed	n_{max}	min^{-1}	7000		
Motor mass ^{3) 5)}	m	kg	4,4		
Perm. storage and transport temp.	T_L	°C	-20 to +80		
Permissible ambient temperature ⁶⁾	T_{um}	°C	0 to 40		
Max. setup height ⁶⁾	h	m	1000 über NN		
Protection category ⁷⁾			IP65		
Insulation class (according to DIN VDE 0530 Part 1)			F		
Housing coat			Prime coat black in a/w RAL 9005		
¹⁾ K_m is to be used for calculations with crest values (I_{dN} , I_{max}). For calculations with root-mean-square values (rated data), the torque constant K_m must be multiplied by a factor of $\sqrt{2}$. ²⁾ Values determined according to EN 60034-1. Current and voltage specified as root-mean-square values. ³⁾ Use the declared value in bracket for motors holding brake. ⁴⁾ Applicable to REXROTH cables. Rated according to VDE0298-4 (1992) and installation type B2 according to EN 60204-1 (1993) at an ambient temperature of 40 °C. ⁵⁾ Without blower unit. ⁶⁾ If the limits specified are exceeded, the performance data must be reduced if necessary. For reduction factors, refer to the chapter entitled "Environmental Conditions". ⁷⁾ Provided the power and encoder cables are mounted properly					

Fig. 7-1: Technical data MKD041B-058

Description	Symbol	Unit	MKD041B-143		
Cooling mode – Motor overtemperature			Natural 60K	Natural 100K	Surface 60K /100K
Electric parameters					
Characteristic motor speed	n_K	min^{-1}	6000		
Continuous torque at standstill	M_{dN}	Nm	2,1	2,9	---
Continuous current at standstill	I_{dN}	A	5,9	6,5	---
Peak current	I_{max}	A	34,0		
Torque constant at 20°C ¹⁾	K_m	Nm/A	0,4		
Voltage constant at 20°C	$K_{E(\text{eff})}$	V/1000min ⁻¹	36,3		
Winding resistance at 20°C	R_{12}	Ω	1,8		
Winding inductance	L_{12}	mH	5		
Number of pole pairs	p		3		
Rated data ²⁾					
Rated speed	n_N	min^{-1}	3000	3000	---
Rated torque	M_N	Nm	0,82	1,38	---
Rated current	I_N	A	1,6	2,8	---
Rated power	P_N	kW	0,32	0,54	---
Rated voltage	U_N	V	112	115	---
Rated frequency	f_N	Hz	150	150	---
Mechanical parameters					
Rotor inertia	J_M	kgm^2	$1,7 \times 10^{-4}$		
Theoretical maximum torque	M_{max}	Nm	11,3		
Minimum strand cross-section ⁴⁾	S	mm^2	1	1	---
Thermal time constant	T_{th}	min	30	30	---
Maximum speed	n_{max}	min^{-1}	7500		
Motor mass ^{3) 5)}	m	kg	4,4		
Perm. storage and transport temp.	T_L	°C	-20 to +80		
Permissible ambient temperature ⁶⁾	T_{um}	°C	0 to 40		
Max. setup height ⁶⁾	h	m	1000 über NN		
Protection category ⁷⁾			IP65		
Insulation class (according to DIN VDE 0530 Part 1)			F		
Housing coat			without		
¹⁾ K_m is to be used for calculations with crest values (I_{dN} , I_{max}). For calculations with root-mean-square values (rated data), the torque constant K_m must be multiplied by a factor of $\sqrt{2}$. ²⁾ Values determined according to EN 60034-1. Current and voltage specified as root-mean-square values. ³⁾ Use the declared value in bracket for motors holding brake. ⁴⁾ Applicable to REXROTH cables. Rated according to VDE0298-4 (1992) and installation type B2 according to EN 60204-1 (1993) at an ambient temperature of 40 °C. ⁵⁾ Without blower unit. ⁶⁾ If the limits specified are exceeded, the performance data must be reduced if necessary. For reduction factors, refer to the chapter entitled "Environmental Conditions". ⁷⁾ Provided the power and encoder cables are mounted properly					

Fig. 7-2: Technical data MKD041B-143

Description	Symbol	Unit	MKD041B-144		
Cooling mode – Motor overtemperature			Natural 60K	Natural 100K	Surface 60K /100K
Electric parameters					
Characteristic motor speed	n_K	min^{-1}	6000		
Continuous torque at standstill	M_{dN}	Nm	2,7	2,9	---
Continuous current at standstill	I_{dN}	A	7,5	8,2	---
Peak current	I_{max}	A	34,0		
Torque constant at 20°C ¹⁾	K_m	Nm/A	0,4		
Voltage constant at 20°C	$K_{E(\text{eff})}$	V/1000min ⁻¹	36,3		
Winding resistance at 20°C	R_{12}	Ω	1,8		
Winding inductance	L_{12}	mH	5		
Number of pole pairs	p		3		
Rated data ²⁾					
Rated speed	n_N	min^{-1}	3000	4500	---
Rated torque	M_N	Nm	1,4	1,5	---
Rated current	I_N	A	2,8	3	---
Rated power	P_N	kW	0,52	0,88	---
Rated voltage	U_N	V	115	170	---
Rated frequency	f_N	Hz	150	225	---
Mechanical parameters					
Rotor inertia	J_M	kgm^2	$1,7 \times 10^{-4}$		
Theoretical maximum torque	M_{max}	Nm	11,3		
Minimum strand cross-section ⁴⁾	S	mm^2	1	1	---
Thermal time constant	T_{th}	min	30	30	---
Maximum speed	n_{max}	min^{-1}	7500		
Motor mass ^{3) 5)}	m	kg	4,4		
Perm. storage and transport temp.	T_L	°C	-20 to +80		
Permissible ambient temperature ⁶⁾	T_{um}	°C	0 to 40		
Max. setup height ⁶⁾	h	m	1000 above NN		
Protection category ⁷⁾			IP65		
Insulation class (according to DIN VDE 0530 Part 1)			F		
Housing coat			Prime coat black in a/w RAL 9005		
¹⁾ K_m is to be used for calculations with crest values (I_{dN} , I_{max}). For calculations with root-mean-square values (rated data), the torque constant K_m must be multiplied by a factor of $\sqrt{2}$. ²⁾ Values determined according to EN 60034-1. Current and voltage specified as root-mean-square values. ³⁾ Use the declared value in bracket for motors holding brake. ⁴⁾ Applicable to REXROTH cables. Rated according to VDE0298-4 (1992) and installation type B2 according to EN 60204-1 (1993) at an ambient temperature of 40 °C. ⁵⁾ Without blower unit. ⁶⁾ If the limits specified are exceeded, the performance data must be reduced if necessary. For reduction factors, refer to the chapter entitled "Environmental Conditions". ⁷⁾ Provided the power and encoder cables are mounted properly.					

Fig. 7-3: Technical data MKD041B-144

Holding Brake

Description	Symbol	Unit	Holding brake data
Holding torque	M_4	Nm	2,2
Rated voltage (+/- 10%)	U_N	V	24
Rated current	I_N	A	0,34
Moment of inertia	J_B	kgm^2	$0,1 \times 10^{-4}$
Clamping delay	t_1	ms	14
Release delay	t_2	ms	28
Mass	m_B	kg	0,23

Fig. 7-4: Technical data of holding brake MKD041 (option)

7.2 Type code – Ordering Name

Abbrev. Column	1	2	3	4	5	6	7	8	9	1	2	3	4	5	6	7	8	9	2	0	1	2	3	4	5	6	7	8	9	3	0	1	2	3	4	5	6	7	8	9	4	0
Example:	M	K	D	0	4	1	B	-	1	4	4	-	G	G	0	-	K	N																								

1. **Product**
 - 1.1 MKD..... = MKD
2. **Size**
 - 2.1 041..... = 041
3. **Length**
 - 3.1 Lengths = B
4. **Winding code ①**
 - 4.1 MKD041B..... = 058, 143, 144
5. **Encoder**
 - 5.1 Resolver feedback = G
 - 5.2 Resolver feedback with integrated multiturn absolute encoder = K
6. **Driven shaft**
 - 6.1 plain shaft (with shaft sealing ring) = G
 - 6.2 Shaft with key acc. to DIN 6885-1 (with shaft sealing ring) = P
7. **Holding brake**
 - 7.1 without holding brake = 0
 - 7.2 Holding brake 2.2 Nm. = 1
8. **Output direction of power connection ②**
 - 8.1 Terminal box (delivering: to B-side) = K
9. **Housing design**
 - 9.1 Standard = N
 - 9.2 Ex type for cluster II, category 3, G and D acc. to DIN EN 50021 = S
10. **Standard reference**

Standard	Designation	Edition
DIN 6885-1	Drive Type with Fastenings without Taper Action; Parallel Keys, Keyways, Deep Pattern	1968-08
DIN EN 50021	Electrical apparatus for potentially explosive atmospheres, Type of protection "n"	2000-02

Note:

- ① Windings code "143" is identical to windings code "144" and not lacquered
Windings code "143" is only available with housing design "N"
- ② Looking from front onto driven shaft

Illustration example: MKD041

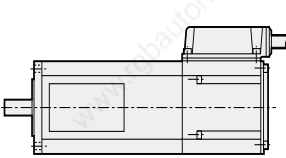

RNC-41650-401_NOR_E_D0_2004-03-25.EPS

Fig. 7-5: MKD041 type code

7.3 Speed – Torque – Characteristics

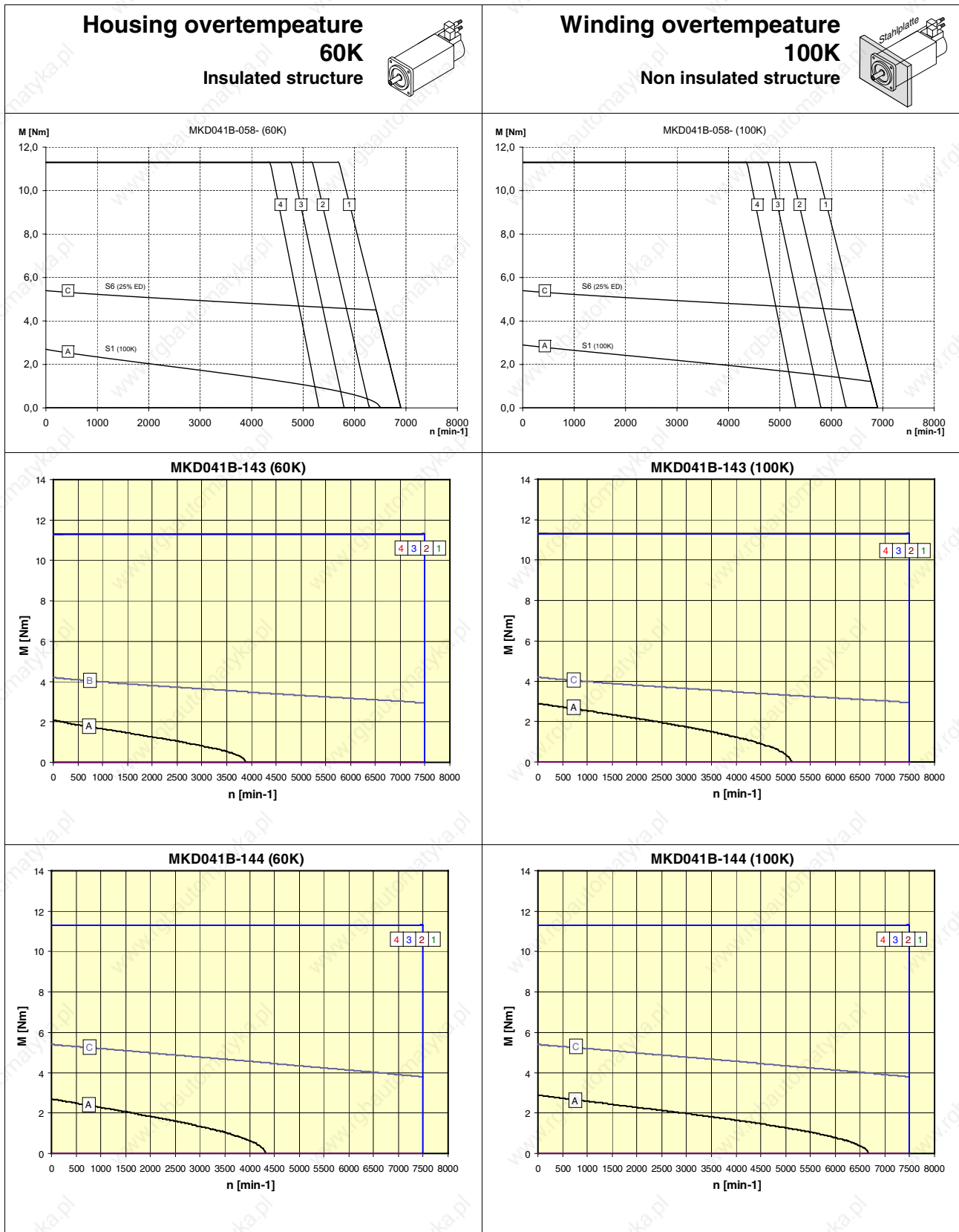

- [A]: M_{dN} Natural conv. (S1 continuous operation)
- [C]: M_{KB} (S6 intermittent operation)
- [1]: HDS to HVR
- [2]: HDS to HVE or DKCxx.3 with a power connection of 3x AC 480V
- [3]: HDS to HVE or DKCxx.3 with a power connection of 3x AC 440V
- [4]: HDS to HVE or DKCxx.3 with a power connection of 3x AC 400V

Fig. 7-6: Speed – torque – characteristics

7.4 Shaft Load

Permissible maximum radial force $F_{\text{radial_max}}$ and permissible radial force F_{radial}

For explanations refer to chapter 13-12.

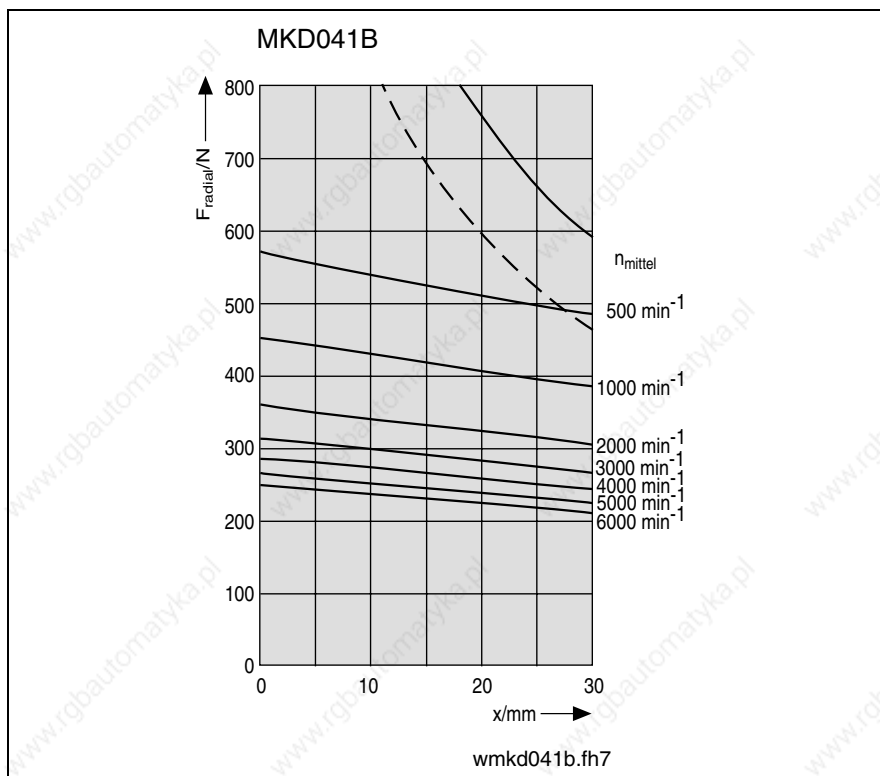

- (1): $F_{\text{radial_max}}$ (plain shaft)
 (2): $F_{\text{radial_max}}$ (shaft with keyway)

Fig. 7-7: MKD041: Permissible maximum radial force $F_{\text{radial_max}}$ and permissible radial force F_{radial}

Permissible axial force F_{axial}

$$F_{\text{axial}} = x \cdot F_{\text{radial}}$$

x : 0,45 for MKD041B

F_{axial} : permissible axial force in N

F_{radial} : permissible radial force in N

Fig. 7-8: MKD041: permissible axial force F_{axial}

7.5 Dimensions

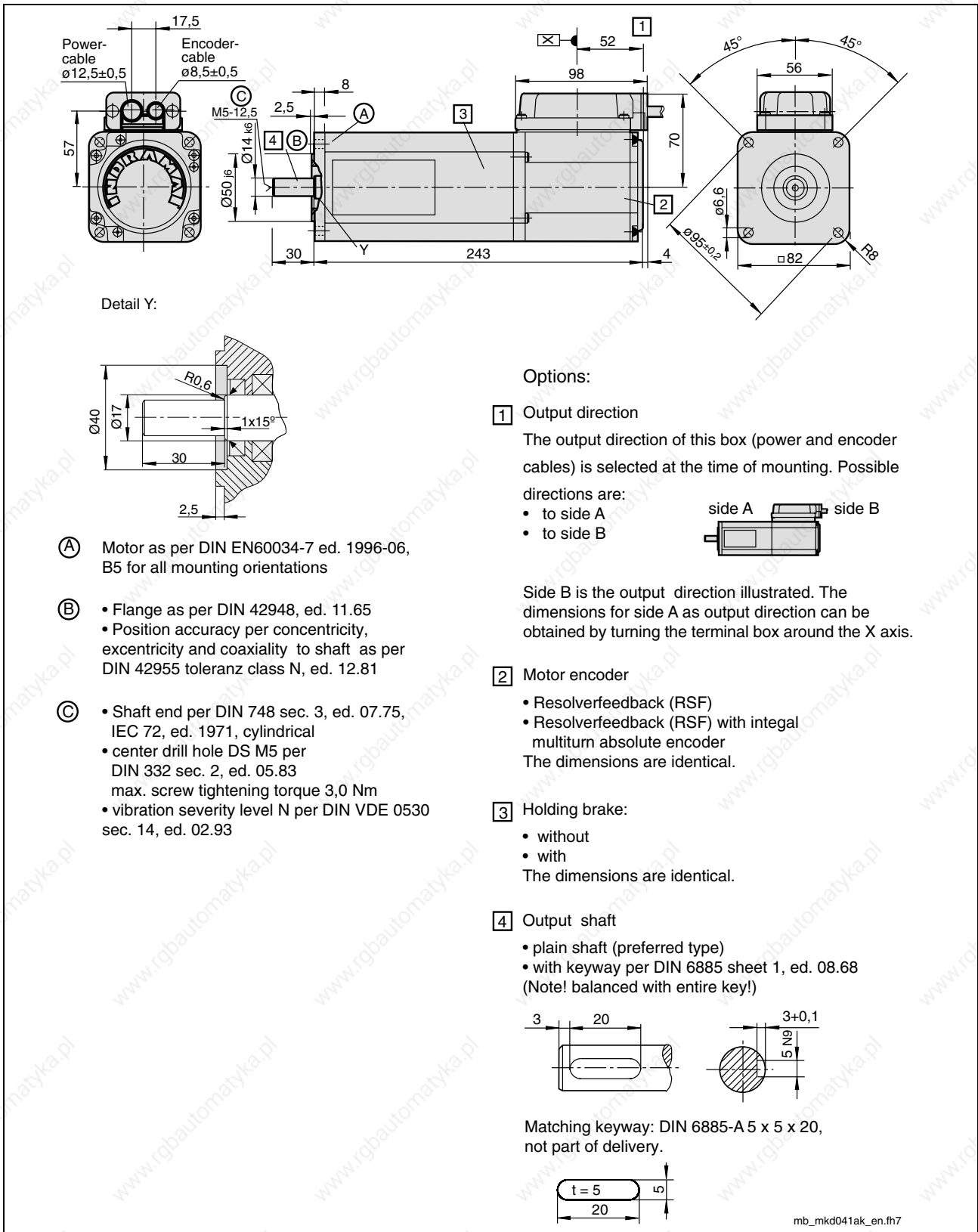

Fig. 7-9: Dimensional data MKD041

8 MKD071

8.1 Technical Data

Description	Symbol	Unit	MKD071B-024		
			Natural 60K	Natural 100K	Surface 60K /100K
Cooling mode – Motor overtemperature					
Electric parameters					
Characteristic motor speed	n_K	min^{-1}	2000		
Continuous torque at standstill	M_{dN}	Nm	8,0	9,0	12,0
Continuous current at standstill	I_{dN}	A	4,4	5,1	6,6
Peak current	I_{max}	A	19,8		
Torque constant at 20°C ¹⁾	K_m	Nm/A	2,01		
Voltage constant at 20°C	$K_{E(\text{eff})}$	V/1000min ⁻¹	174,9		
Winding resistance at 20°C	R_{12}	Ω	8,4		
Winding inductance	L_{12}	mH	34,4		
Number of pole pairs	p		4		
Rated data ²⁾					
Rated speed	n_N	min^{-1}	2000	2000	2000
Rated torque	M_N	Nm	5,8	6,8	10,5
Rated current	I_N	A	2,2	2,7	4,1
Rated power	P_N	kW	1,4	1,8	2,7
Rated voltage	U_N	V	372	377	395
Rated frequency	f_N	Hz	100	100	100
Mechanical parameters					
Rotor inertia	J_M	kgm^2	$8,7 \times 10^{-4}$		
Theoretical maximum torque	M_{max}	Nm	32		
Minimum strand cross-section ⁴⁾	S	mm^2	1	1	1
Thermal time constant	T_{th}	min	45	45	20
Maximum speed	n_{max}	min^{-1}	4000		
Motor mass ^{3) 5)}	m	kg	8,8		
Perm. storage and transport temp.	T_L	°C	-20 to +80		
Permissible ambient temperature ⁶⁾	T_{um}	°C	0 to +40		
Max. setup height ⁶⁾	h	m	1000 above NN		
Protection category ⁷⁾			IP65		
Insulation class (according to DIN VDE 0530 Part 1)			F		
Housing coat			Prime coat black in a/w RAL 9005		
¹⁾ K_m is to be used for calculations with crest values (I_{dN} , I_{max}). For calculations with root-mean-square values (rated data), the torque constant K_m must be multiplied by a factor of $\sqrt{2}$. ²⁾ Values determined according to EN 60034-1. Current and voltage specified as root-mean-square values. ³⁾ Use the declared value in bracket for motors holding brake. ⁴⁾ Applicable to REXROTH cables. Rated according to VDE0298-4 (1992) and installation type B2 according to EN 60204-1 (1993) at an ambient temperature of 40 °C. ⁵⁾ Without blower unit. ⁶⁾ If the limits specified are exceeded, the performance data must be reduced if necessary. For reduction factors, refer to the chapter entitled "Environmental Conditions". ⁷⁾ Provided the power and encoder cables are mounted properly					

Fig. 8-1: Technical data MKD071B-024

Description	Symbol	Unit	MKD071B-035		
			Natural 60K	Natural 100K	Surface 60K /100K
Cooling mode – Motor overtemperature					
Electric parameters					
Characteristic motor speed	n_K	min^{-1}	2500		
Continuous torque at standstill	M_{dN}	Nm	8,0	9,0	12,0
Continuous current at standstill	I_{dN}	A	6,3	7,4	9,5
Peak current	I_{max}	A	28,3		
Torque constant at 20°C ¹⁾	K_m	Nm/A	1,38		
Voltage constant at 20°C	$K_{E(eff)}$	V/1000min ⁻¹	125		
Winding resistance at 20°C	R_{12}	Ω	4,57		
Winding inductance	L_{12}	mH	23		
Number of pole pairs	p		4		
Rated data ²⁾					
Rated speed	n_N	min^{-1}	2500	2500	2500
Rated torque	M_N	Nm	5,2	7,5	10,2
Rated current	I_N	A	2,9	4,4	5,7
Rated power	P_N	kW	1,6	2,5	3,4
Rated voltage	U_N	V	333	349	366
Rated frequency	f_N	Hz	167	167	167
Mechanical parameters					
Rotor inertia	J_M	kgm^2	$8,7 \times 10^{-4}$		
Theoretical maximum torque	M_{max}	Nm	32		
Minimum strand cross-section ⁴⁾	S	mm^2	1	1	1
Thermal time constant	T_{th}	min	45	45	20
Maximum speed	n_{max}	min^{-1}	4500		
Motor mass ^{3) 5)}	m	kg	8,8		
Perm. storage and transport temp.	T_L	°C	-20 to +80		
Permissible ambient temperature ⁶⁾	T_{um}	°C	0 to +40		
Max. setup height ⁶⁾	h	m	1000 above NN		
Protection category ⁷⁾			IP65		
Insulation class (according to DIN VDE 0530 Part 1)			F		
Housing coat			Prime coat black in a/w RAL 9005		
¹⁾ K_m is to be used for calculations with crest values (I_{dN} , I_{max}). For calculations with root-mean-square values (rated data), the torque constant K_m must be multiplied by a factor of $\sqrt{2}$. ²⁾ Values determined according to EN 60034-1. Current and voltage specified as root-mean-square values. ³⁾ Use the declared value in bracket for motors holding brake. ⁴⁾ Applicable to REXROTH INDRAMAT cables. Rated according to VDE0298-4 (1992) and installation type B2 according to EN 60204-1 (1993) at an ambient temperature of 40 °C. ⁵⁾ Without blower unit. ⁶⁾ If the limits specified are exceeded, the performance data must be reduced if necessary. For reduction factors, refer to the chapter entitled "Environmental Conditions". ⁷⁾ Provided the power and encoder cables are mounted properly					

Fig. 8-2: Technical data MKD071B-035

Description	Symbol	Unit	MKD071B-061		
			Natural 60K	Natural 100K	Surface 60K /100K
Cooling mode – Motor overtemperature					
Electric parameters					
Characteristic motor speed	n_K	min^{-1}	4500		
Continuous torque at standstill	M_{dN}	Nm	8,0	9,0	12,0
Continuous current at standstill	I_{dN}	A	11,2	13,2	16,8
Peak current	I_{max}	A	50,4		
Torque constant at 20°C ¹⁾	K_m	Nm/A	0,77		
Voltage constant at 20°C	$K_{E(\text{eff})}$	V/1000min ⁻¹	70		
Winding resistance at 20°C	R_{12}	Ω	1,45		
Winding inductance	L_{12}	mH	7,2		
Number of pole pairs	p		4		
Rated data ²⁾					
Rated speed	n_N	min^{-1}	4000	5000	5000
Rated torque	M_N	Nm	1,7	5,3	7,8
Rated current	I_N	A	1,7	5,5	7,7
Rated power	P_N	kW	0,8	3,4	4,8
Rated voltage	U_N	V	283	368	380
Rated frequency	f_N	Hz	267	333	333
Mechanical parameters					
Rotor inertia	J_M	kgm^2	$8,7 \times 10^{-4}$		
Theoretical maximum torque	M_{max}	Nm	32		
Minimum strand cross-section ⁴⁾	S	mm^2	1	1	1
Thermal time constant	T_{th}	min	45	45	20
Maximum speed	n_{max}	min^{-1}	6000		
Motor mass ^{3) 5)}	m	kg	8,8		
Perm. storage and transport temp.	T_L	$^{\circ}\text{C}$	-20 to +80		
Permissible ambient temperature ⁶⁾	T_{um}	$^{\circ}\text{C}$	0 to 40		
Max. setup height ⁶⁾	h	m	1000 above NN		
Protection category ⁷⁾			IP65		
Insulation class (according to DIN VDE 0530 Part 1)			F		
Housing coat			Prime coat black in a/w RAL 9005		
¹⁾ K_m is to be used for calculations with crest values (I_{dN} , I_{max}). For calculations with root-mean-square values (rated data), the torque constant K_m must be multiplied by a factor of $\sqrt{2}$. ²⁾ Values determined according to EN 60034-1. Current and voltage specified as root-mean-square values. ³⁾ Use the declared value in bracket for motors holding brake. ⁴⁾ Applicable to REXROTH cables. Rated according to VDE0298-4 (1992) and installation type B2 according to EN 60204-1 (1993) at an ambient temperature of 40 $^{\circ}\text{C}$. ⁵⁾ Without blower unit. ⁶⁾ If the limits specified are exceeded, the performance data must be reduced if necessary. For reduction factors, refer to the chapter entitled "Environmental Conditions". ⁷⁾ Provided the power and encoder cables are mounted properly					

Fig. 8-3: Technical data MKD071B-061

Holding brake

Description	Symbol	Unit	Holding brake 1	Holding brake 3
Holding torque	M_4	Nm	5,0	10,0
Rated voltage (+/- 10%)	U_N	V	24	24
Rated current	I_N	A	0,56	0,65
Moment of inertia	J_B	kgm ²	$0,72 \times 10^{-4}$	$1,07 \times 10^{-4}$
Clamping delay	t_1	ms	20	26
Release delay	t_2	ms	38	43
Mass	m_B	kg	0,62	0,7

Fig. 8-4: Technical data of holding brake MKD071 (option)

8.2 Type code – Ordering Name

Abbrev.	1	2	3	4	5	6	7	8	9	1	2	3	4	5	6	7	8	9	2	3	4	5	6	7	8	9	3	4	5	6	7	8	9	4
Column	1	2	3	4	5	6	7	8	9	1	2	3	4	5	6	7	8	9	0	1	2	3	4	5	6	7	8	9	0	1	2	3	4	
Example:	M	K	D	0	7	1	B	-	0	6	1	-	G	G	0	-	K	N																

- 1. Product**
 - 1.1 MKD = MKD
- 2. Motor size**
 - 2.1 071 = 071
- 3. Motor length**
 - 3.1 Length = B
- 4. Windings code**
 - 4.1 MKD071B = 024, 035, 061
- 5. Motor encoder**
 - 5.1 Resolver feedback = G
 - 5.2 Resolver feedback with integrated multiturn absolute encoder = K
- 6. Driven shaft**
 - 6.1 plain shaft (with shaft sealing ring) = G
 - 6.2 Shaft with key per DIN 6885-1 (with shaft sealing ring) = P
- 7. Holding brake**
 - 7.1 without holding brake = 0
 - 7.2 Holding brake 5 Nm = 1
 - 7.3 Holding brake 10 Nm = 3
- 8. Output direction of power connection ①**
 - 8.1 Junction box (delivering: to side B) = K
- 9. Housing design**
 - 9.1 standard = N
 - 9.2 Ex type for cluster II, category 3, G and D on DIN EN 50021 = S
- 10. Standard reference**

Standard	Title	Edition
DIN 6885-1	Drive Type with Fastenings without Taper Action; Parallel Keys, Keyways, Deep Pattern	1968-08
DIN EN 50021	Electrical apparatus for potentially explosive atmospheres, Type of protection "n"	2000-02

Note:
 ① Looking from front onto driven shaft (see picture 1)

Illustration example: MKD071

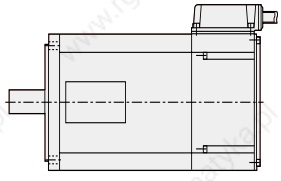

Position of power connection = top

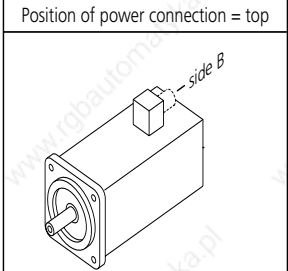

Picture 1

INN-41-65-T07-01-M09-MKD.EPS

Fig. 8-5: MKD071 type code

8.3 Speed – Torque – Characteristics

**Housing overtemperature
60K
Insulated structure**

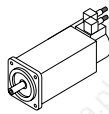

**Winding overtemperature
100K
Non insulated structure**

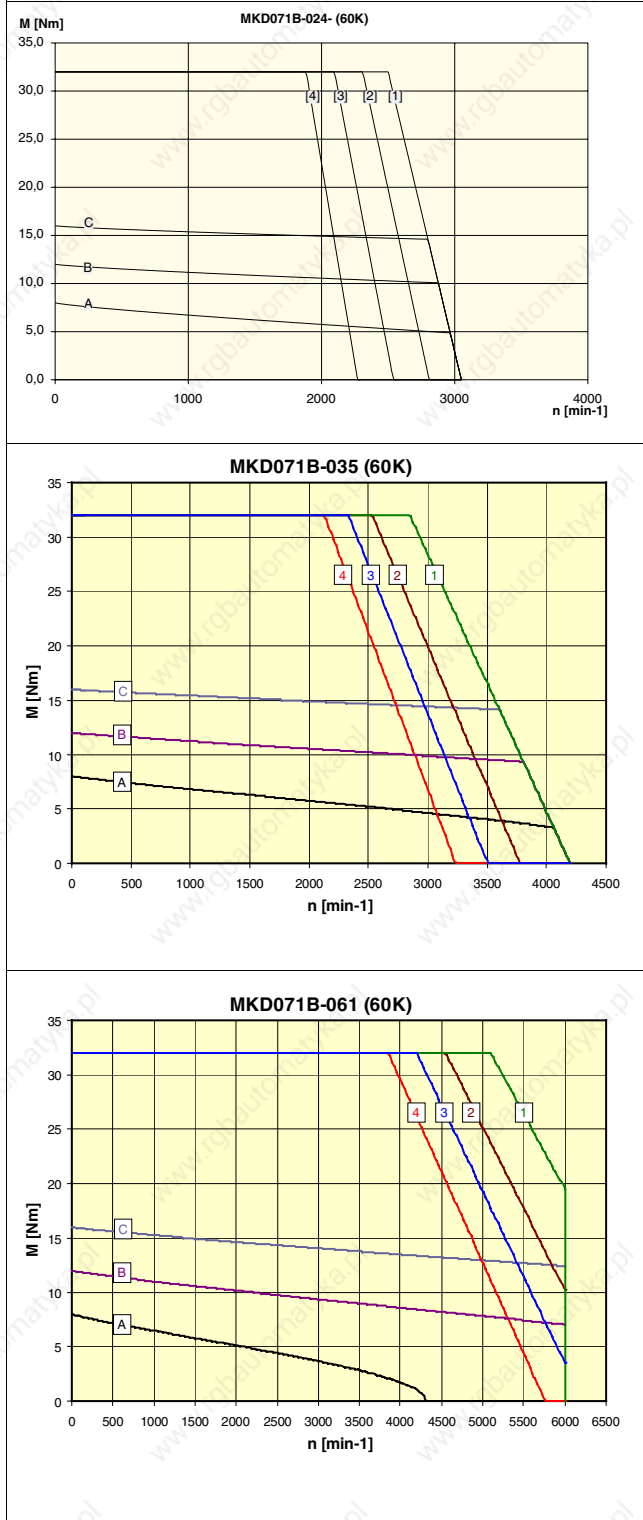
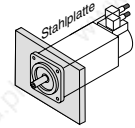

- [A]: M_{dN} Natural conv. (S1 continuous operation)
- [B]: M_{dN} Surface cooling (S1 continuous operation)
- [C]: M_{kB} (S6 intermittent operation)
- [1]: HDS to HVR
- [2]: HDS to HVE or DKCxx.3 with a power connection of 3x AC 480V
- [3]: HDS to HVE or DKCxx.3 with a power connection of 3x AC 440V
- [4]: HDS to HVE or DKCxx.3 with a power connection of 3x AC 400V

Fig. 8-6: Speed – torque – characteristics

8.4 Shaft Load

Permissible maximum radial force $F_{\text{radial_max}}$ and permissible radial force F_{radial}

For explanations refer to page 13-12.

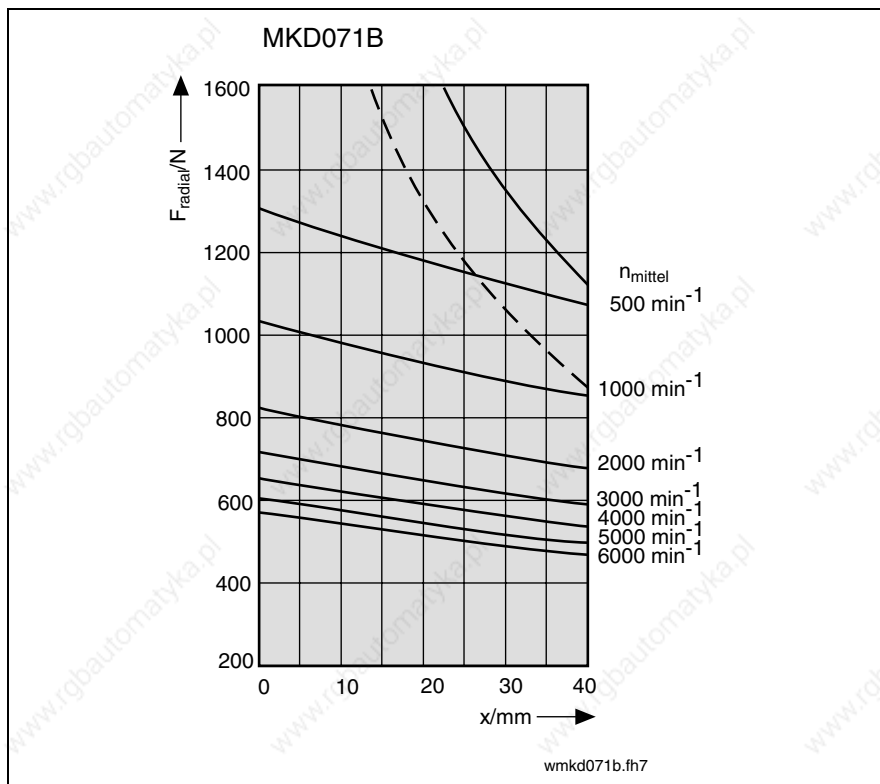

- (1): $F_{\text{radial_max}}$ (plain shaft)
 (2): $F_{\text{radial_max}}$ (shaft with keyway)

Fig. 8-7: MKD071 Permissible maximum radial force $F_{\text{radial_max}}$ and permissible radial force F_{radial}

Permissible axial force F_{axial}

$$F_{\text{axial}} = x \cdot F_{\text{radial}}$$

- x : 0,55 for MKD071B
 F_{axial} : permissible axial force in N
 F_{radial} : permissible radial force in N

Fig. 8-8: MKD071: permissible axial force F_{axial}

8.5 Dimensions

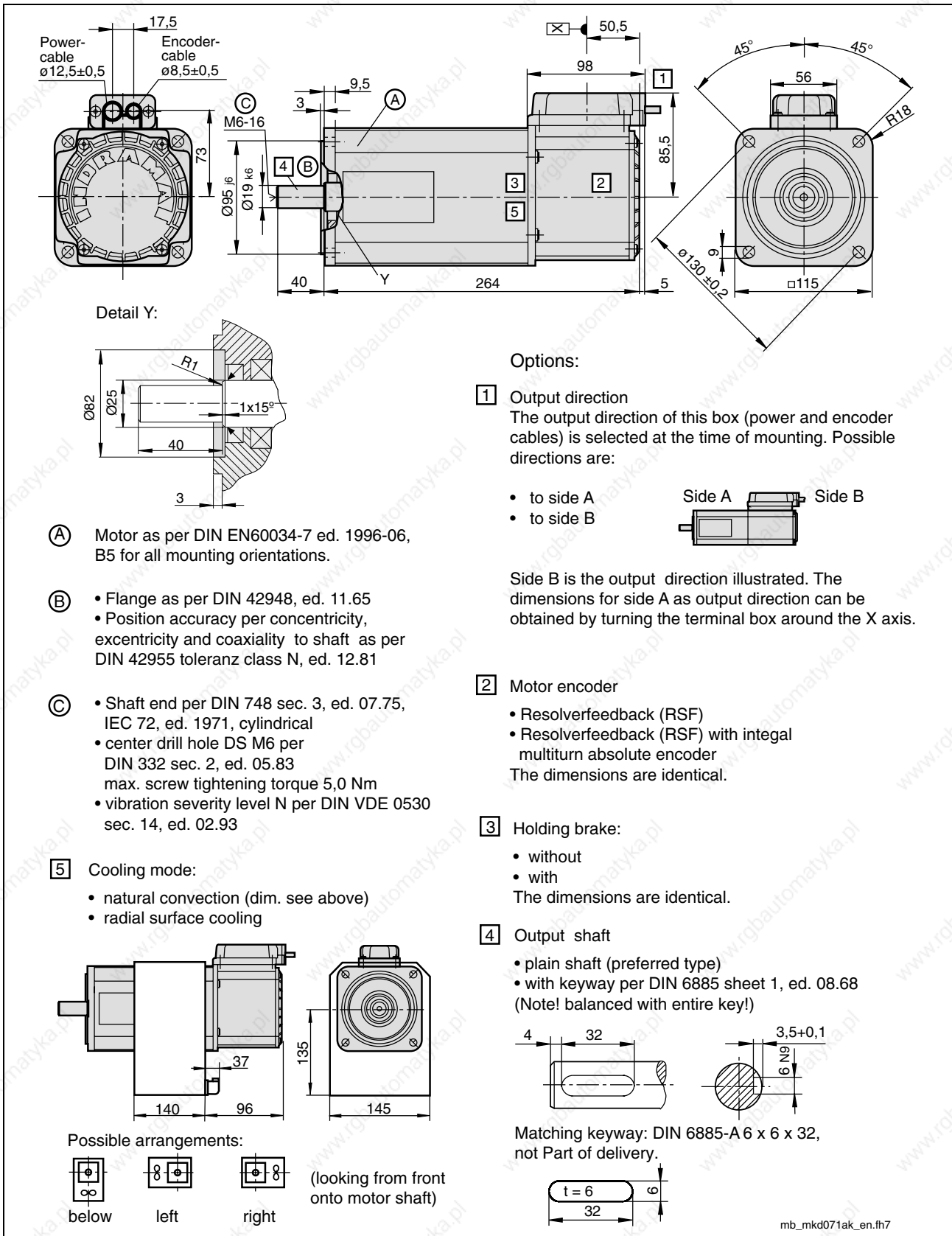

Fig. 8-9: Dimensional data MKD071 (holding brake 1)

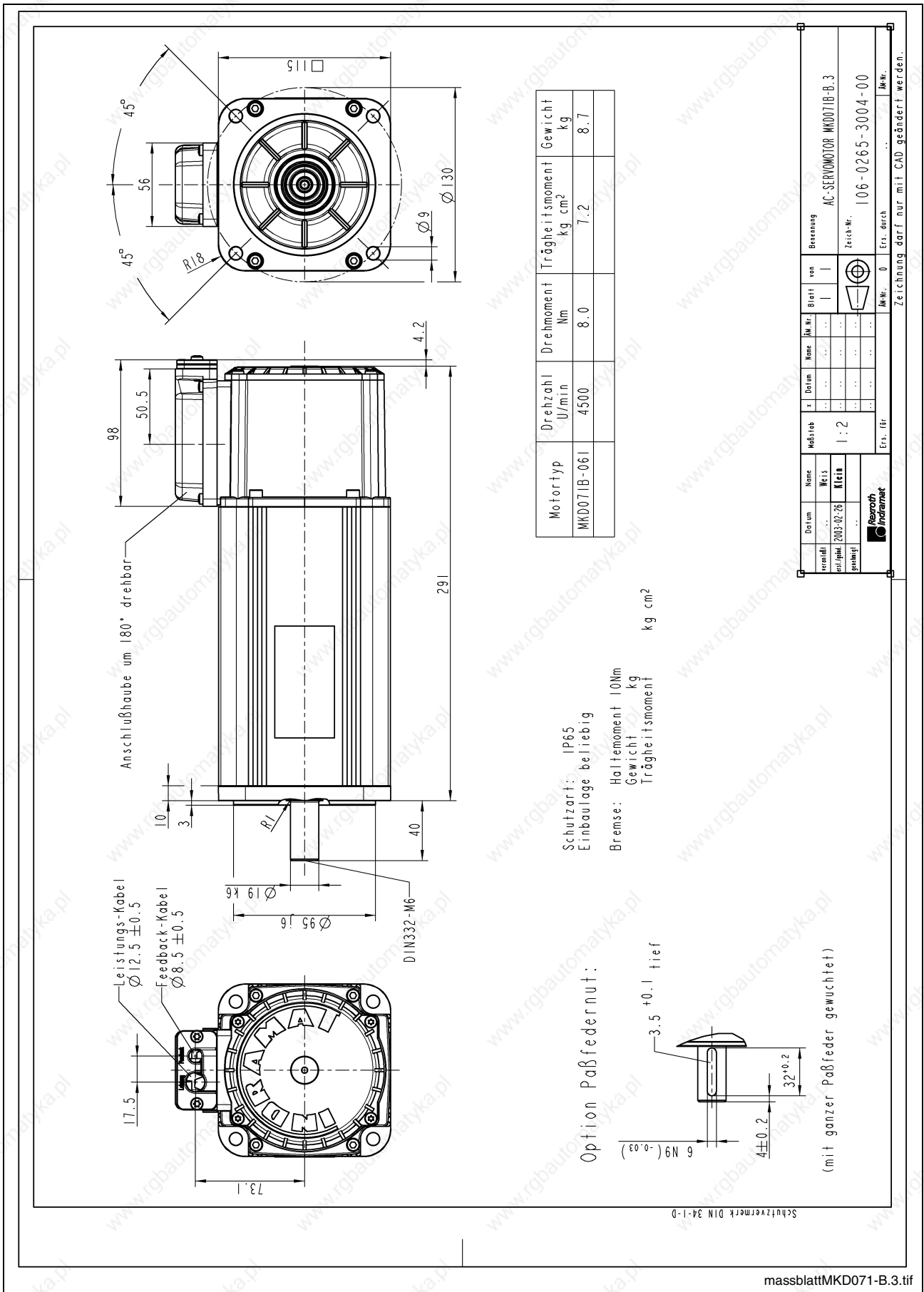

Fig. 8-10: Dimensional data MKD071 (holding brake 3)

8.6 Blower Units

MKD motors can also be delivered with optional blower units. Please refer to the „Surface“ column of the data sheets for performance data of surface-cooled motors. The mechanical dimensions of the blower units are represented in the dimension drawings. The possibilities of combining motor and blower unit and the technical data of the blowers are represented in the table below.

Motor			Ordering name of blower unit			
			LEMD-RB071B1XX	LEMD-RB071B2XX		
MKD071B			x	x		
Technical data of blower unit						
Description	Symbol	Unit				
Type of cooling			radial		axial	
Rated voltage	U_n	V	230V, $\pm 15\%$ 50Hz	115V, $\pm 10\%$ 60Hz	not available	not available
Rated power	P_n	W	18	17		
Rated current	I	A	0,13	0,28		
Mean air volume	V	m ³ /h	180	206		
Blower unit mass	m_L	kg				
Noise level		dB(A)	44	47		
Air flow			B A blasend			
--- Blower installation not possible;			x Blower installation possible			

Fig. 8-11: Technical data of MKD071 blower units (optional)

9 MKD090

9.1 Technical Data

Description	Symbol	Unit	MKD090B-035		
			Natural 60K	Natural 100K	Surface 60K /100K
Cooling mode – Motor overtemperature					
Electric parameters					
Characteristic motor speed	n_K	min^{-1}	2500		
Continuous torque at standstill	M_{dN}	Nm	12,0	13,5	18,0
Continuous current at standstill	I_{dN}	A	11,0	12,5	16,5
Peak current	I_{max}	A	49,5		
Torque constant at 20°C ¹⁾	K_m	Nm/A	1,22		
Voltage constant at 20°C	$K_{E(eff)}$	V/1000min ⁻¹	111		
Winding resistance at 20°C	R_{12}	Ω	1,88		
Winding inductance	L_{12}	mH	15,5		
Number of pole pairs	p		4		
Rated data ²⁾					
Rated speed	n_N	min^{-1}	3000	3000	3000
Rated torque	M_N	Nm	7,2	10,2	15
Rated current	I_N	A	4,7	6,7	9,7
Rated power	P_N	kW	2,8	4	5,9
Rated voltage	U_N	V	354	369	399
Rated frequency	f_N	Hz	200	200	200
Mechanical parameters					
Rotor inertia	J_M	kgm^2	$43,0 \times 10^{-4}$		
Theoretical maximum torque	M_{max}	Nm	43,5		
Minimum strand cross-section ⁴⁾	S	mm^2	1	1	1
Thermal time constant	T_{th}	min	60	60	30
Maximum speed	n_{max}	min^{-1}	5000		
Motor mass ^{3) 5)}	m	kg	14,0		
Perm. storage and transport temp.	T_L	°C	-20 to +80		
Permissible ambient temperature ⁶⁾	T_{um}	°C	0 to 40		
Max. setup height ⁶⁾	h	m	1000 above NN		
Protection category ⁷⁾			IP65		
Insulation class (according to DIN VDE 0530 Part 1)			F		
Housing coat			Prime coat black in a/w RAL 9005		
¹⁾ K_m is to be used for calculations with crest values (I_{dN} , I_{max}). For calculations with root-mean-square values (rated data), the torque constant K_m must be multiplied by a factor of $\sqrt{2}$. ²⁾ Values determined according to EN 60034-1. Current and voltage specified as root-mean-square values. ³⁾ Use the declared value in bracket for motors holding brake. ⁴⁾ Applicable to REXROTH cables. Rated according to VDE0298-4 (1992) and installation type B2 according to EN 60204-1 (1993) at an ambient temperature of 40 °C. ⁵⁾ Without blower unit. ⁶⁾ If the limits specified are exceeded, the performance data must be reduced if necessary. For reduction factors, refer to the chapter entitled "Environmental Conditions". ⁷⁾ Provided the power and encoder cables are mounted properly					

Fig. 9-1: Technical data MKD090B-035

Description	Symbol	Unit	MKD090B-046		
			Natural 60K	Natural 100K	Surface 60K /100K
Cooling mode – Motor overtemperature					
Electric parameters					
Characteristic motor speed	n_K	min^{-1}	3200		
Continuous torque at standstill	M_{dN}	Nm	9,3	10,5	---
Continuous current at standstill	I_{dN}	A	10,4	12,6	---
Peak current	I_{max}	A	59,4		
Torque constant at 20°C ¹⁾	K_m	Nm/A	1		
Voltage constant at 20°C	$K_{E(\text{eff})}$	V/1000min ⁻¹	91		
Winding resistance at 20°C	R_{12}	Ω	1,2		
Winding inductance	L_{12}	mH	10,1		
Number of pole pairs	p		4		
Rated data ²⁾					
Rated speed	n_N	min^{-1}	3500	3500	---
Rated torque	M_N	Nm	3,2	6,7	---
Rated current	I_N	A	2,5	5,7	---
Rated power	P_N	kW	1,4	3,2	---
Rated voltage	U_N	V	324	336	---
Rated frequency	f_N	Hz	233	233	---
Mechanical parameters					
Rotor inertia	J_M	kgm^2	$43,0 \times 10^{-4}$		
Theoretical maximum torque	M_{max}	Nm	43,5		
Minimum strand cross-section ⁴⁾	S	mm^2	1	1	---
Thermal time constant	T_{th}	min	60	60	---
Maximum speed	n_{max}	min^{-1}	5000		
Motor mass ^{3) 5)}	m	kg	14,0		
Perm. storage and transport temp.	T_L	°C	-20 to +80		
Permissible ambient temperature ⁶⁾	T_{um}	°C	0 to 40		
Max. setup height ⁶⁾	h	m	1000 above NN		
Protection category ⁷⁾			IP65		
Insulation class (according to DIN VDE 0530 Part 1)			F		
Housing coat			without		
¹⁾ K_m is to be used for calculations with crest values (I_{dN} , I_{max}). For calculations with root-mean-square values (rated data), the torque constant K_m must be multiplied by a factor of $\sqrt{2}$. ²⁾ Values determined according to EN 60034-1. Current and voltage specified as root-mean-square values. ³⁾ Use the declared value in bracket for motors holding brake. ⁴⁾ Applicable to REXROTH cables. Rated according to VDE0298-4 (1992) and installation type B2 according to EN 60204-1 (1993) at an ambient temperature of 40 °C. ⁵⁾ Without blower unit. ⁶⁾ If the limits specified are exceeded, the performance data must be reduced if necessary. For reduction factors, refer to the chapter entitled "Environmental Conditions". ⁷⁾ Provided the power and encoder cables are mounted properly					

Fig. 9-2: Technical data MKD090B-046

Description	Symbol	Unit	MKD090B-047		
			Natural 60K	Natural 100K	Surface 60K /100K
Cooling mode – Motor overtemperature					
Electric parameters					
Characteristic motor speed	n_K	min^{-1}	3200		
Continous torque at standstill	M_{dN}	Nm	12,0	13,5	15,0
Continous current at standstill	I_{dN}	A	13,3	14,4	16,6
Peak current	I_{max}	A	59,4		
Torque constant at 20°C ¹⁾	K_m	Nm/A	1,05		
Voltage constant at 20°C	$K_{E(\text{eff})}$	V/1000min ⁻¹	91		
Winding resistance at 20°C	R_{12}	Ω	1,2		
Winding inductance	L_{12}	mH	10,1		
Number of pole pairs	p		4		
Rated data ²⁾					
Rated speed	n_N	min^{-1}	3500	3500	3500
Rated torque	M_N	Nm	6,2	9,9	14,4
Rated current	I_N	A	4,8	8,4	11,2
Rated power	P_N	kW	2,7	4,8	6,4
Rated voltage	U_N	V	332	351	371
Rated frequency	f_N	Hz	233	233	233
Mechanical parameters					
Rotor inertia	J_M	kgm^2	$43,0 \times 10^{-4}$		
Theoretical maximum torque	M_{max}	Nm	43,5		
Minimum strand cross-section ⁴⁾	S	mm^2	1	1	1,5
Thermal time constant	T_{th}	min	60	60	30
Maximum speed	n_{max}	min^{-1}	5000		
Motor mass ^{3) 5)}	m	kg	14,0		
Perm. storage and transport temp.	T_L	$^{\circ}\text{C}$	-20 to +80		
Permissible ambient temperature ⁶⁾	T_{um}	$^{\circ}\text{C}$	0 to 40		
Max. setup height ⁶⁾	h	m	1000 above NN		
Protection category ⁷⁾			IP65		
Insulation class (according to DIN VDE 0530 Part 1)			F		
Housing coat			Prime coat black in a/w RAL 9005		
¹⁾ K_m is to be used for calculations with crest values (I_{dN} , I_{max}). For calculations with root-mean-square values (rated data), the torque constant K_m must be multiplied by a factor of $\sqrt{2}$. ²⁾ Values determined according to EN 60034-1. Current and voltage specified as root-mean-square values. ³⁾ Use the declared value in bracket for motors holding brake. ⁴⁾ Applicable to REXROTH cables. Rated according to VDE0298-4 (1992) and installation type B2 according to EN 60204-1 (1993) at an ambient temperature of 40 $^{\circ}\text{C}$. ⁵⁾ Without blower unit. ⁶⁾ If the limits specified are exceeded, the performance data must be reduced if necessary. For reduction factors, refer to the chapter entitled "Environmental Conditions". ⁷⁾ Provided the power and encoder cables are mounted properly					

Fig. 9-3 Technical data MKD090B-047

Description	Symbol	Unit	MKD090B-058		
			Natural 60K	Natural 100K	Surface 60K /100K
Cooling mode – Motor overtemperature					
Electric parameters					
Characteristic motor speed	n_K	min^{-1}	4000		
Continuous torque at standstill	M_{dN}	Nm	12,0	12,0	12,0
Continuous current at standstill	I_{dN}	A	17,2	17,2	17,2
Peak current	I_{max}	A	79,0		
Torque constant at 20°C ¹⁾	K_m	Nm/A	0,81		
Voltage constant at 20°C	$K_{E(\text{eff})}$	V/1000min ⁻¹	70		
Winding resistance at 20°C	R_{12}	Ω	0,74		
Winding inductance	L_{12}	mH	5,8		
Number of pole pairs	p		4		
Rated data ²⁾					
Rated speed	n_N	min^{-1}	4000	4000	4000
Rated torque	M_N	Nm	4,2	8,9	12
Rated current	I_N	A	4,3	9,2	12,4
Rated power	P_N	kW	2,1	4,6	6,2
Rated voltage	U_N	V	286	300	313
Rated frequency	f_N	Hz	267	267	267
Mechanical parameters					
Rotor inertia	J_M	kgm^2	$43,0 \times 10^{-4}$		
Theoretical maximum torque	M_{max}	Nm	43,5		
Minimum strand cross-section ⁴⁾	S	mm^2	1	1	1,5
Thermal time constant	T_{th}	min	60	60	30
Maximum speed	n_{max}	min^{-1}	5000		
Motor mass ^{3) 5)}	m	kg	14,0		
Perm. storage and transport temp.	T_L	°C	-20 to +80		
Permissible ambient temperature ⁶⁾	T_{um}	°C	0 to 40		
Max. setup height ⁶⁾	h	m	1000 above NN		
Protection category ⁷⁾			IP65		
Insulation class (according to DIN VDE 0530 Part 1)			F		
Housing coat			Prime coat black in a/w RAL 9005		
¹⁾ K_m is to be used for calculations with crest values (I_{dN} , I_{max}). For calculations with root-mean-square values (rated data), the torque constant K_m must be multiplied by a factor of $\sqrt{2}$. ²⁾ Values determined according to EN 60034-1. Current and voltage specified as root-mean-square values. ³⁾ Use the declared value in bracket for motors holding brake. ⁴⁾ Applicable to REXROTH cables. Rated according to VDE0298-4 (1992) and installation type B2 according to EN 60204-1 (1993) at an ambient temperature of 40 °C. ⁵⁾ Without blower unit. ⁶⁾ If the limits specified are exceeded, the performance data must be reduced if necessary. For reduction factors, refer to the chapter entitled "Environmental Conditions". ⁷⁾ Provided the power and encoder cables are mounted properly					

Fig. 9-4: Technical data MKD090B-058

Holding Brake

Description	Symbol	Unit	Holding brake 1	Holding brake 2
Holding torque	M_4	Nm	11.0	18.0
Rated voltage (+/- 10%)	U_N	V	24	24
Rated current	I_N	A	0.71	0.71
Moment of inertia	J_B	kgm^2	3.6×10^{-4}	3.13×10^{-4}
Clamping delay	t_1	ms	13	16
Release delay	t_2	ms	30	90
Mass	m_B	kg	1.1	1.0

Fig. 9-5: Technical data of holding brake MKD090 (option)

9.2 Type code – Ordering Name

Abbrev.	Column	1	2	3	4	5	6	7	8	9	0	1	2	3	4	5	6	7	8	9	0	1	2	3	4	5	6	7	8	9	0	1	2	3	4	5	6	7	8	9	0
Example:		M	K	D	0	9	0	B	-	0	4	7	-	G	G	0	-	K	N																						

- 1. Product**
 - 1.1 MKD..... = MKD
- 2. Motor size**
 - 2.1 090..... = 090
- 3. Motor length**
 - 3.1 Length..... = B
- 4. Windings code^①**
 - 4.1 MKD090B..... = 035, 046, 047, 058
- 5. Motor encoder**
 - 5.1 Resolver feedback..... = G
 - 5.2 Resolver feedback with integrated multiturn absolute encoder..... = K
- 6. Driven shaft**
 - 6.1 plain shaft (with shaft sealing ring)..... = G
 - 6.2 Shaft with key per DIN 6885-1 (with shaft sealing ring)..... = P
- 7. Holding brake**
 - 7.1 without holding brake..... = 0
 - 7.2 Holding brake 11 Nm..... = 1
 - 7.3 Holding brake 18 Nm..... = 2
- 8. Output direction of power connection^②**
 - 8.1 Terminal box (delivering: to side B)..... = K
- 9. Housing design**
 - 9.1 standard..... = N
 - 9.2 Ex type for cluster II, category 3, G and D on DIN EN 50021 = S
- 10. Standard reference**

<u>Standard</u>	<u>Title</u>	<u>Edition</u>
DIN 6885-1	Drive Type with Fastenings without Taper Action; Parallel Keys, Keyways, Deep Pattern	1968-08
DIN EN 50021	Electrical apparatus for potentially explosive atmospheres, Type of protection "n"	2000-02

Note:

- ① Windings code "046" is identical to windings code "047" and not painted
Windings code "046" is only available with housing design "N"
- ② Looking from front onto driven shaft

typecodeMKD090_M10en.fh10

Fig. 9-6: MKD090 type code

9.3 Speed – Torque – Characteristics

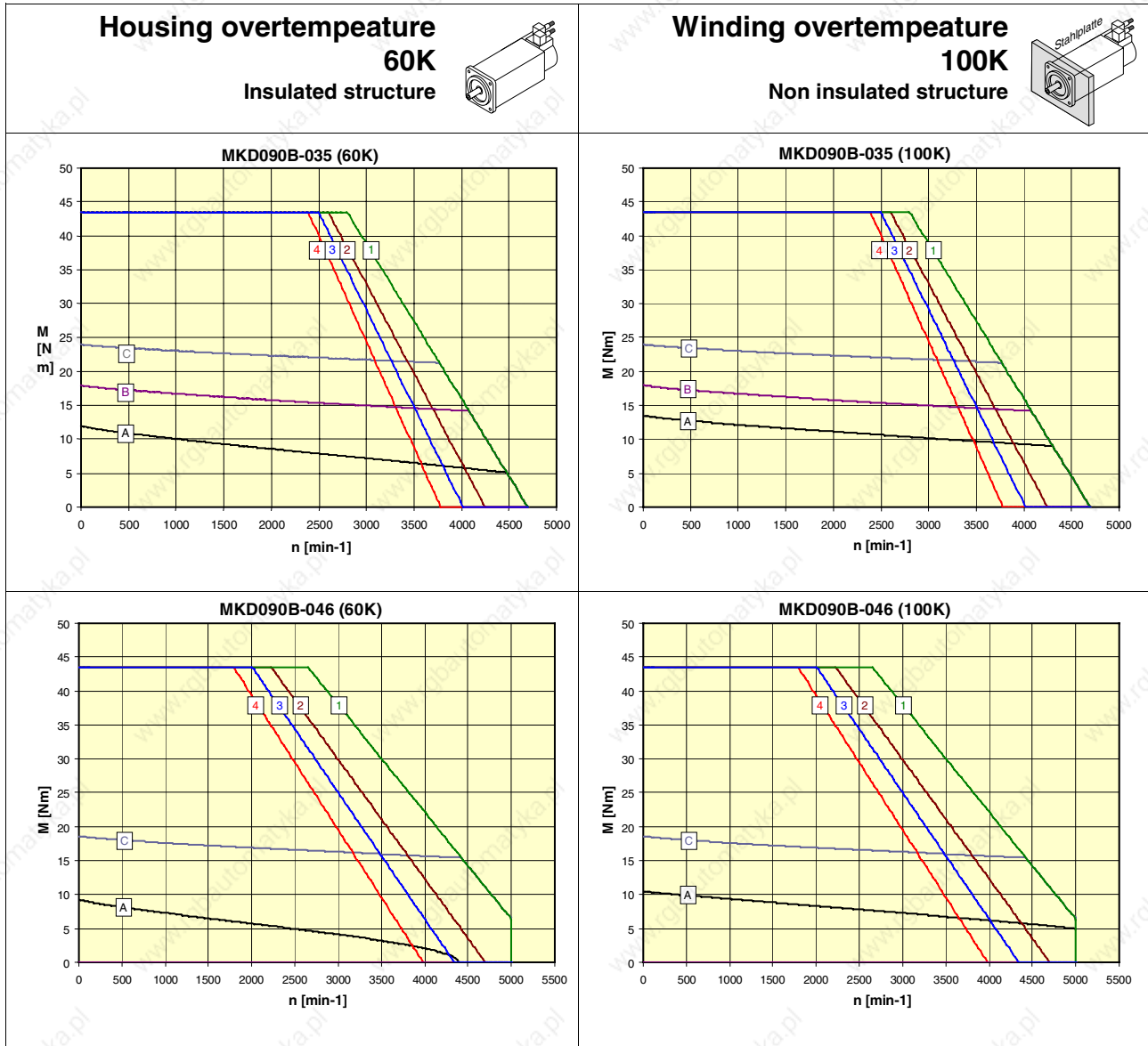

- [A]: M_{dN} Natural conv. (S1 continuous operation)
- [B]: M_{dN} Surface cooling (S1 continuous operation)
- [C]: M_{kB} (S6 intermittent operation)
- [1]: HDS to HVR
- [2]: HDS to HVE or DKCxx.3 with a power connection of 3x AC 480V
- [3]: HDS to HVE or DKCxx.3 with a power connection of 3x AC 440V
- [4]: HDS to HVE or DKCxx.3 with a power connection of 3x AC 400V

Fig. 9-7: Speed – torque - characteristics

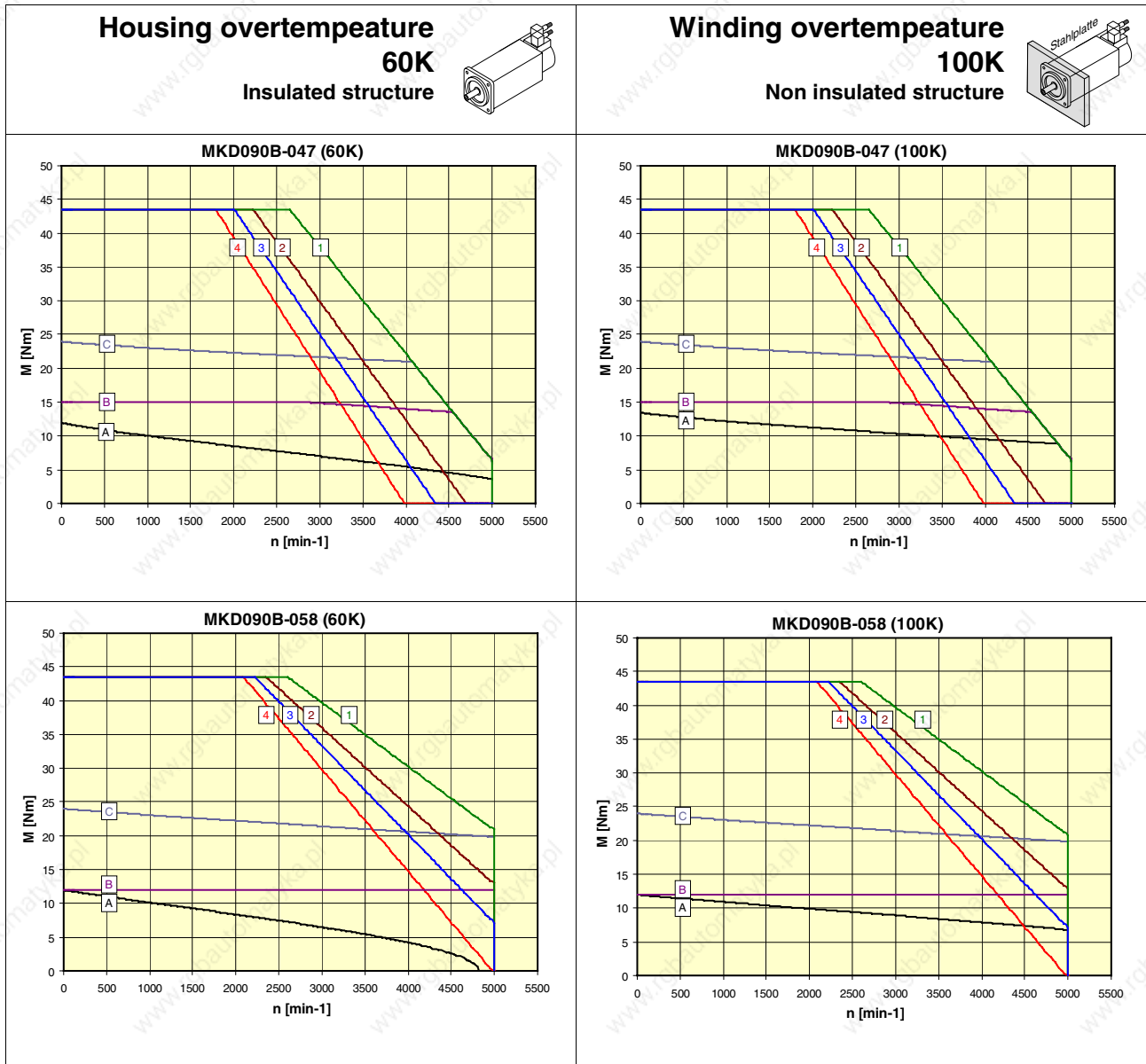

- [A]: M_{dN} Natural conv. (S1 continuous operation)
- [B]: M_{dN} Surface cooling (S1 continuous operation)
- [C]: M_{KB} (S6 intermittent operation)
- [1]: HDS to HVR
- [2]: HDS to HVE or DKCxx.3 with a power connection of 3x AC 480V
- [3]: HDS to HVE or DKCxx.3 with a power connection of 3x AC 440V
- [4]: HDS to HVE or DKCxx.3 with a power connection of 3x AC 400V

Fig. 9-8: Speed – torque - characteristics

9.4 Shaft Load

Permissible maximum radial force $F_{\text{radial_max}}$ and permissible radial force F_{radial}

For explanations refer to page 13-12.

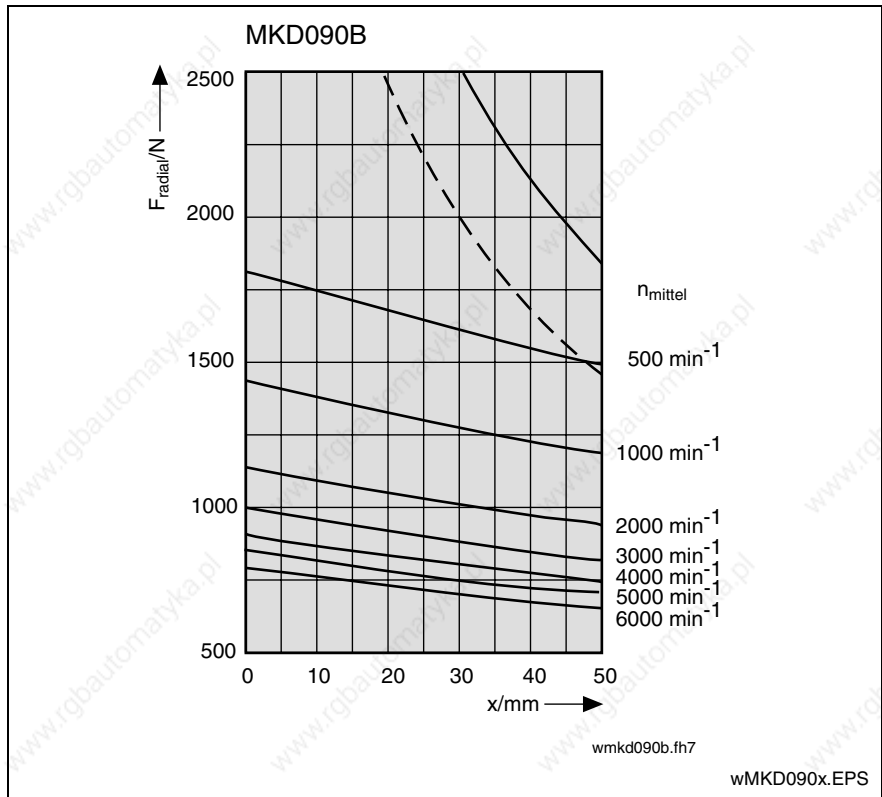

- (1): $F_{\text{radial_max}}$ (plain shaft)
- (2): $F_{\text{radial_max}}$ (shaft with keyway)

Fig. 9-9: MKD090: Permissible maximum radial force $F_{\text{radial_max}}$ and permissible radial force F_{radial}

Permissible axial force F_{axial}

$$F_{\text{axial}} = x \cdot F_{\text{radial}}$$

- x: 0,34 für MKD090B
- F_{axial} : permissible axial force in N
- F_{radial} : permissible radial force in N

Fig. 9-10: MKD090 permissible axial force F_{axial}

9.5 Dimensions

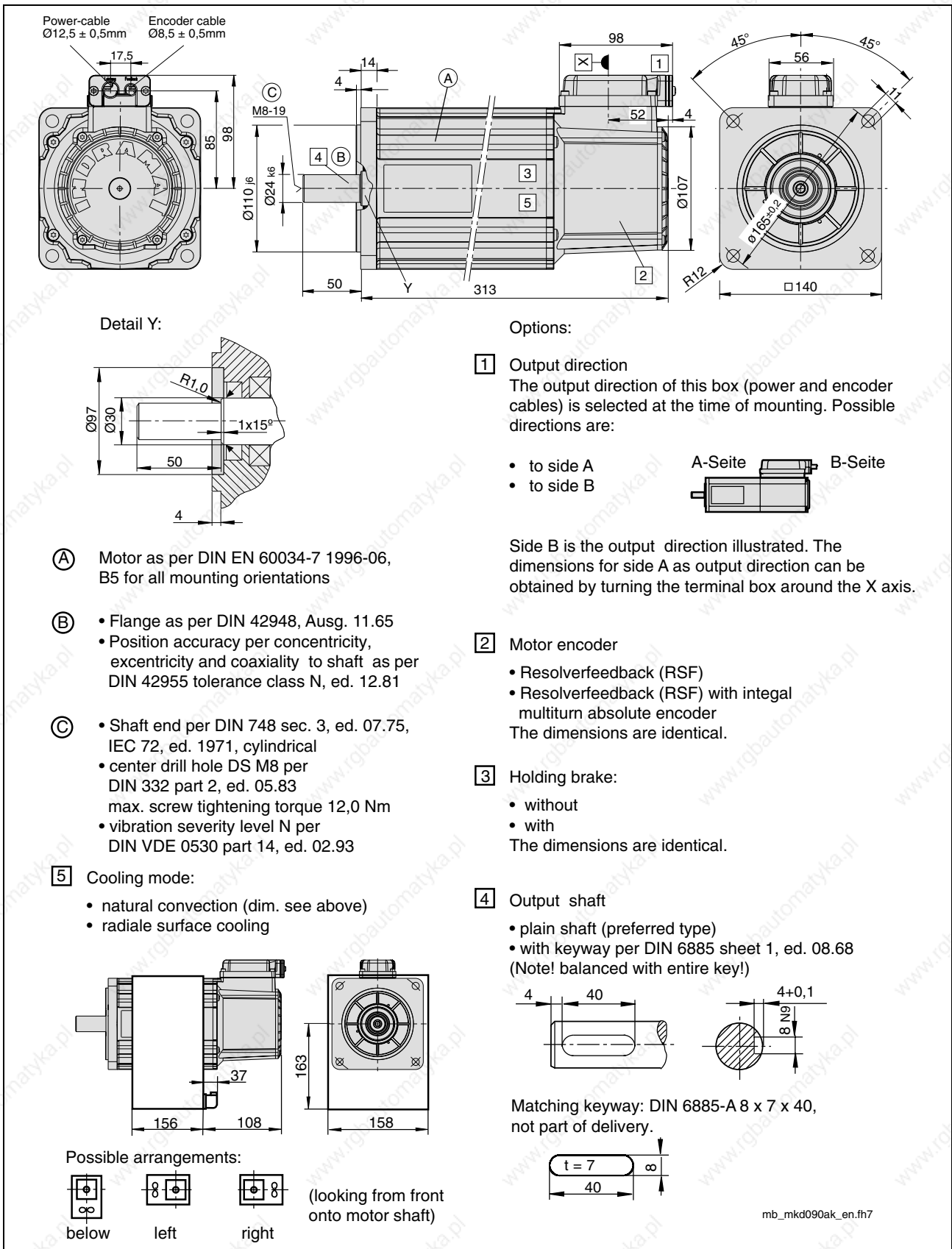

Fig. 9-11: Dimensional data MKD090

9.6 Blower Units

MKD motors can also be delivered with optional blower units. Please refer to the „Surface“ column of the data sheets for performance data of surface-cooled motors. The mechanical dimensions of the blower units are represented in the dimension drawings. The possibilities of combining motor and blower unit and the technical data of the blowers are represented in the table below.

Motor			Ordering name of blower unit			
			LEMH- RB090B1XX	LEMH- RB090B2XX		
MKD090B			x	x		
Technical data of blower unit						
Description	Symbol	Unit				
Type of cooling			radial		axial	
Rated voltage	U _n	V	230V, ± 15% 50 / 60Hz	115V, ± 10% 50 / 60Hz	Not available	Not available
Rated power	P _n	W	45 / 39	41 / 38		
Rated current	I	A	0,20 / 0,17	0,36 / 0,33		
Mean air volume	V	m ³ /h	325 / 380	325 / 380		
Blower unit mass	m _L	kg	1,2	1,1		
Noise level		dB(A)	48 / 52	48 / 52		
Air flow			B A blowing			
--- Blower installation not possible;			x Blower installation possible			

Fig. 9-12: Technical data of MKD090 blower unit (optional)

10 MKD112

10.1 Technical Data

Description	Symbol	Unit	MKD112A-024		
			Natural 60K	Natural 100K	Surface 60K /100K
Cooling mode – Motor overtemperature					

Electric parameters

Characteristic motor speed	n_K	min^{-1}	2000		
Continuous torque at standstill	M_{dN}	Nm	15,0	17,0	22,5
Continuous current at standstill	I_{dN}	A	13,1	15,9	19,7
Peak current	I_{max}	A	59,0		
Torque constant at 20°C ¹⁾	K_m	Nm/A	1,28		
Voltage constant at 20°C	$K_{E(eff)}$	V/1000min ⁻¹	116,4		
Winding resistance at 20°C	R_{12}	Ω	1,45		
Winding inductance	L_{12}	mH	14,0		
Number of pole pairs	p		4		

Rated data ²⁾

Rated speed	n_N	min^{-1}	2500	2500	2500
Rated torque	M_N	Nm	10,1	13,8	19,4
Rated current	I_N	A	6,2	9,1	12
Rated power	P_N	kW	3,2	4,8	6,4
Rated voltage	U_N	V	314	332	355
Rated frequency	f_N	Hz	167	167	167

Mechanical parameters

Rotor inertia	J_M	kgm^2	$110,0 \times 10^{-4}$		
Theoretical maximum torque	M_{max}	Nm	54		
Minimum strand cross-section ⁴⁾	S	mm^2	1,5	1,5	1,5
Thermal time constant	T_{th}	min	40	40	20
Maximum speed	n_{max}	min^{-1}	4000		
Motor mass ^{3) 5)}	m	kg	23,0		
Perm. storage and transport temp.	T_L	°C	-20 to +80		
Permissible ambient temperature ⁶⁾	T_{um}	°C	0 to 40		
Max. setup height ⁶⁾	h	m	1000 above NN		
Protection category ⁷⁾			IP65		
Insulation class (according to DIN VDE 0530 Part 1)			F		
Housing coat			Prime coat black in a/w RAL 9005		

¹⁾ K_m is to be used for calculations with crest values (I_{dN} , I_{max}). For calculations with root-mean-square values (rated data), the torque constant K_m must be multiplied by a factor of $\sqrt{2}$.

²⁾ Values determined according to EN 60034-1. Current and voltage specified as root-mean-square values.

³⁾ Use the declared value in bracket for motors holding brake.

⁴⁾ Applicable to REXROTH INDRAMAT cables. Rated according to VDE0298-4 (1992) and installation type B2 according to EN 60204-1 (1993) at an ambient temperature of 40 °C.

⁵⁾ Without blower unit.

⁶⁾ If the limits specified are exceeded, the performance data must be reduced if necessary. For reduction factors, refer to the chapter entitled "Environmental Conditions".

⁷⁾ Provided the power and encoder cables are mounted properly

Fig. 10-1: Technical data MKD112A-024

Description	Symbol	Unit	MKD112A-058		
			Natural 60K	Natural 100K	Surface 60K /100K
Cooling mode – Motor overtemperature					
Electric parameters					
Characteristic motor speed	n_K	min^{-1}	4000		
Continuous torque at standstill	M_{dN}	Nm	15,0	17,0	22,5
Continuous current at standstill	I_{dN}	A	17,1	20,1	25,7
Peak current	I_{max}	A	77,0		
Torque constant at 20°C ¹⁾	K_m	Nm/A	0,98		
Voltage constant at 20°C	$K_{E(\text{eff})}$	V/1000min ⁻¹	89		
Winding resistance at 20°C	R_{12}	Ω	0,86		
Winding inductance	L_{12}	mH	7,8		
Number of pole pairs	p		4		
Rated data ²⁾					
Rated speed	n_N	min^{-1}	3500	3500	3500
Rated torque	M_N	Nm	7,3	13	17,8
Rated current	I_N	A	5,9	10,9	14,4
Rated power	P_N	kW	3,2	6	8,1
Rated voltage	U_N	V	324	344	363
Rated frequency	f_N	Hz	233	233	233
Mechanical parameters					
Rotor inertia	J_M	kgm^2	110,0 x 10 ⁻⁴		
Theoretical maximum torque	M_{max}	Nm	54		
Minimum strand cross-section ⁴⁾	S	mm^2	1,5	1,5	2,5
Thermal time constant	T_{th}	min	40	40	20
Maximum speed	n_{max}	min^{-1}	4500		
Motor mass ^{3) 5)}	m	kg	23,0		
Perm. storage and transport temp.	T_L	°C	-20 to +80		
Permissible ambient temperature ⁶⁾	T_{um}	°C	0 to 40		
Max. setup height ⁶⁾	h	m	1000 above NN		
Protection category ⁷⁾			IP65		
Insulation class (according to DIN VDE 0530 Part 1)			F		
Housing coat			Prime coat black in a/w RAL 9005		
¹⁾ K_m is to be used for calculations with crest values (I_{dN} , I_{max}). For calculations with root-mean-square values (rated data), the torque constant K_m must be multiplied by a factor of $\sqrt{2}$. ²⁾ Values determined according to EN 60034-1. Current and voltage specified as root-mean-square values. ³⁾ Use the declared value in bracket for motors holding brake. ⁴⁾ Applicable to REXROTH INDRAMAT cables. Rated according to VDE0298-4 (1992) and installation type B2 according to EN 60204-1 (1993) at an ambient temperature of 40 °C. ⁵⁾ Without blower unit. ⁶⁾ If the limits specified are exceeded, the performance data must be reduced if necessary. For reduction factors, refer to the chapter entitled "Environmental Conditions". ⁷⁾ Provided the power and encoder cables are mounted properly					

Fig. 10-2 Technical data MKD112A-058

Description	Symbol	Unit	MKD112B-024		
			Natural 60K	Natural 100K	Surface 60K /100K
Cooling mode – Motor overtemperature					
Electric parameters					
Characteristic motor speed	n_K	min^{-1}	2000		
Continuous torque at standstill	M_{dN}	Nm	28,0	33,0	42,0
Continuous current at standstill	I_{dN}	A	21,9	26,8	32,9
Peak current	I_{max}	A	98,5		
Torque constant at 20°C ¹⁾	K_m	Nm/A	1,43		
Voltage constant at 20°C	$K_{E(\text{eff})}$	V/1000min ⁻¹	130		
Winding resistance at 20°C	R_{12}	Ω	0,58		
Winding inductance	L_{12}	mH	7,6		
Number of pole pairs	p		4		
Rated data ²⁾					
Rated speed	n_N	min^{-1}	3500	3500	3500
Rated torque	M_N	Nm	8,8	21,6	31
Rated current	I_N	A	4,9	12,4	17,2
Rated power	P_N	kW	3,9	9,9	13,8
Rated voltage	U_N	V	461	483	503
Rated frequency	f_N	Hz	233	233	233
Mechanical parameters					
Rotor inertia	J_M	kgm^2	$192,0 \times 10^{-4}$		
Theoretical maximum torque	M_{max}	Nm	102		
Minimum strand cross-section ⁴⁾	S	mm^2	1,5	2,5	4
Thermal time constant	T_{th}	min	40	40	20
Maximum speed	n_{max}	min^{-1}	4000		
Motor mass ^{3) 5)}	m	kg	34,0		
Perm. storage and transport temp.	T_L	°C	-20 to +80		
Permissible ambient temperature ⁶⁾	T_{um}	°C	0 to 40		
Max. setup height ⁶⁾	h	m	1000 above NN		
Protection category ⁷⁾			IP65		
Insulation class (according to DIN VDE 0530 Part 1)			F		
Housing coat			Prime coat black in a/w RAL 9005		
¹⁾ K_m is to be used for calculations with crest values (I_{dN} , I_{max}). For calculations with root-mean-square values (rated data), the torque constant K_m must be multiplied by a factor of $\sqrt{2}$. ²⁾ Values determined according to EN 60034-1. Current and voltage specified as root-mean-square values. ³⁾ Use the declared value in bracket for motors holding brake. ⁴⁾ Applicable to REXROTH INDRAMAT cables. Rated according to VDE0298-4 (1992) and installation type B2 according to EN 60204-1 (1993) at an ambient temperature of 40 °C. ⁵⁾ Without blower unit. ⁶⁾ If the limits specified are exceeded, the performance data must be reduced if necessary. For reduction factors, refer to the chapter entitled "Environmental Conditions". ⁷⁾ Provided the power and encoder cables are mounted properly					

Fig. 10-3: Technical data MKD112B-024

Description	Symbol	Unit	MKD112B-048		
			Natural 60K	Natural 100K	Surface 60K /100K
Cooling mode – Motor overtemperature					
Electric parameters					
Characteristic motor speed	n_K	min^{-1}	3500		
Continuous torque at standstill	M_{dN}	Nm	28,0	33,0	42,0
Continuous current at standstill	I_{dN}	A	35,6	43,5	53,4
Peak current	I_{max}	A	160,2		
Torque constant at 20°C ¹⁾	K_m	Nm/A	0,88		
Voltage constant at 20°C	$K_{E(\text{eff})}$	V/1000min ⁻¹	80		
Winding resistance at 20°C	R_{12}	Ω	0,22		
Winding inductance	L_{12}	mH	3,1		
Number of pole pairs	p		4		
Rated data ²⁾					
Rated speed	n_N	min^{-1}	2800	2800	2800
Rated torque	M_N	Nm	7,7	18,1	30,6
Rated current	I_N	A	6,9	16,9	27,5
Rated power	P_N	kW	2,7	6,7	11
Rated voltage	U_N	V	227	236	251
Rated frequency	f_N	Hz	187	187	187
Mechanical parameters					
Rotor inertia	J_M	kgm^2	$192,0 \times 10^{-4}$		
Theoretical maximum torque	M_{max}	Nm	102		
Minimum strand cross-section ⁴⁾	S	mm^2	4	6	6
Thermal time constant	T_{th}	min	40	40	20
Maximum speed	n_{max}	min^{-1}	4500		
Motor mass ^{3) 5)}	m	kg	34,0		
Perm. storage and transport temp.	T_L	$^{\circ}\text{C}$	-20 to +80		
Permissible ambient temperature ⁶⁾	T_{um}	$^{\circ}\text{C}$	0 to 40		
Max. setup height ⁶⁾	h	m	1000 above NN		
Protection category ⁷⁾			IP65		
Insulation class (according to DIN VDE 0530 Part 1)			F		
Housing coat			Prime coat black in a/w RAL 9005		
¹⁾ K_m is to be used for calculations with crest values (I_{dN} , I_{max}). For calculations with root-mean-square values (rated data), the torque constant K_m must be multiplied by a factor of $\sqrt{2}$. ²⁾ Values determined according to EN 60034-1. Current and voltage specified as root-mean-square values. ³⁾ Use the declared value in bracket for motors holding brake. ⁴⁾ Applicable to REXROTH INDRAMAT cables. Rated according to VDE0298-4 (1992) and installation type B2 according to EN 60204-1 (1993) at an ambient temperature of 40 °C. ⁵⁾ Without blower unit. ⁶⁾ If the limits specified are exceeded, the performance data must be reduced if necessary. For reduction factors, refer to the chapter entitled "Environmental Conditions". ⁷⁾ Provided the power and encoder cables are mounted properly					

Fig. 10-4: Technical data MKD112B-048

Description	Symbol	Unit	MKD112B-058		
			Natural 60K	Natural 100K	Surface 60K /100K
Cooling mode – Motor overtemperature					
Electric parameters					
Characteristic motor speed	n_K	min^{-1}	4000		
Continuous torque at standstill	M_{dN}	Nm	28,0	33,0	42,0
Continuous current at standstill	I_{dN}	A	40,7	51,4	61,0
Peak current	I_{max}	A	183,0		
Torque constant at 20°C ¹⁾	K_m	Nm/A	0,77		
Voltage constant at 20°C	$K_{E(\text{eff})}$	V/1000min ⁻¹	70		
Winding resistance at 20°C	R_{12}	Ω	0,17		
Winding inductance	L_{12}	mH	2,2		
Number of pole pairs	p		4		
Rated data ²⁾					
Rated speed	n_N	min^{-1}	3000	4000	4000
Rated torque	M_N	Nm	6,2	11,9	26
Rated current	I_N	A	6,4	13,1	26,7
Rated power	P_N	kW	2,3	6,4	13,2
Rated voltage	U_N	V	212	286	301
Rated frequency	f_N	Hz	200	267	267
Mechanical parameters					
Rotor inertia	J_M	kgm^2	$192,0 \times 10^{-4}$		
Theoretical maximum torque	M_{max}	Nm	102		
Minimum strand cross-section ⁴⁾	S	mm^2	4	6	10
Thermal time constant	T_{th}	min	40	40	20
Maximum speed	n_{max}	min^{-1}	4500		
Motor mass ^{3) 5)}	m	kg	34,0		
Perm. storage and transport temp.	T_L	$^{\circ}\text{C}$	-20 to +80		
Permissible ambient temperature ⁶⁾	T_{um}	$^{\circ}\text{C}$	0 to 40		
Max. setup height ⁶⁾	h	m	1000 above NN		
Protection category ⁷⁾			IP65		
Insulation class (according to DIN VDE 0530 Part 1)			F		
Housing coat			Prime coat black in a/w RAL 9005		
¹⁾ K_m is to be used for calculations with crest values (I_{dN} , I_{max}). For calculations with root-mean-square values (rated data), the torque constant K_m must be multiplied by a factor of $\sqrt{2}$. ²⁾ Values determined according to EN 60034-1. Current and voltage specified as root-mean-square values. ³⁾ Use the declared value in bracket for motors holding brake. ⁴⁾ Applicable to REXROTH INDRAMAT cables. Rated according to VDE0298-4 (1992) and installation type B2 according to EN 60204-1 (1993) at an ambient temperature of 40 °C. ⁵⁾ Without blower unit. ⁶⁾ If the limits specified are exceeded, the performance data must be reduced if necessary. For reduction factors, refer to the chapter entitled "Environmental Conditions". ⁷⁾ Provided the power and encoder cables are mounted properly					

Fig. 10-5: Technical data MKD112B-058

Description	Symbol	Unit	MKD112C-024		
			Natural 60K	Natural 100K	Surface 60K /100K
Cooling mode – Motor overtemperature					
Electric parameters					
Characteristic motor speed	n_K	min^{-1}	2000		
Continuous torque at standstill	M_{dN}	Nm	38,0	43,5	57,0
Continuous current at standstill	I_{dN}	A	26,6	32,6	39,9
Peak current	I_{max}	A	120,0		
Torque constant at 20°C ¹⁾	K_m	Nm/A	1,6		
Voltage constant at 20°C	$K_{E(\text{eff})}$	V/1000min ⁻¹	145,5		
Winding resistance at 20°C	R_{12}	Ω	0,44		
Winding inductance	L_{12}	mH	6,7		
Number of pole pairs	p		4		
Rated data ²⁾					
Rated speed	n_N	min^{-1}	2500	2500	2500
Rated torque	M_N	Nm	16,6	32,6	44,1
Rated current	I_N	A	8,2	17,3	21,8
Rated power	P_N	kW	5,2	11,1	14,1
Rated voltage	U_N	V	372	391	404
Rated frequency	f_N	Hz	167	167	167
Mechanical parameters					
Rotor inertia	J_M	kgm^2	$273,0 \times 10^{-4}$		
Theoretical maximum torque	M_{max}	Nm	148		
Minimum strand cross-section ⁴⁾	S	mm^2	2,5	4	4
Thermal time constant	T_{th}	min	90	90	40
Maximum speed	n_{max}	min^{-1}	4000		
Motor mass ^{3) 5)}	m	kg	45,0		
Perm. storage and transport temp.	T_L	°C	-20 to +80		
Permissible ambient temperature ⁶⁾	T_{um}	°C	0 to 40		
Max. setup height ⁶⁾	h	m	1000 above NN		
Protection category ⁷⁾			IP65		
Insulation class (according to DIN VDE 0530 Part 1)			F		
Housing coat			Prime coat black in a/w RAL 9005		
¹⁾ K_m is to be used for calculations with crest values (I_{dN} , I_{max}). For calculations with root-mean-square values (rated data), the torque constant K_m must be multiplied by a factor of $\sqrt{2}$. ²⁾ Values determined according to EN 60034-1. Current and voltage specified as root-mean-square values. ³⁾ Use the declared value in bracket for motors holding brake. ⁴⁾ Applicable to REXROTH INDRAMAT cables. Rated according to VDE0298-4 (1992) and installation type B2 according to EN 60204-1 (1993) at an ambient temperature of 40 °C. ⁵⁾ Without blower unit. ⁶⁾ If the limits specified are exceeded, the performance data must be reduced if necessary. For reduction factors, refer to the chapter entitled "Environmental Conditions". ⁷⁾ Provided the power and encoder cables are mounted properly.					

Fig. 10-6: Technical data MKD112C-024

Description	Symbol	Unit	MKD112C-058		
			Natural 60K	Natural 100K	Surface 60K /100K
Cooling mode – Motor overtemperature					
Electric parameters					
Characteristic motor speed	n_K	min^{-1}	4000		
Continous torque at standstill	M_{dN}	Nm	38,0	43,5	57,0
Continous current at standstill	I_{dN}	A	53,2	65,3	79,8
Peak current	I_{max}	A	239,0		
Torque constant at 20°C ¹⁾	K_m	Nm/A	0,8		
Voltage constant at 20°C	$K_{E(\text{eff})}$	V/1000min ⁻¹	72,7		
Winding resistance at 20°C	R_{12}	Ω	0,12		
Winding inductance	L_{12}	mH	1,5		
Number of pole pairs	p		4		
Rated data ²⁾					
Rated speed	n_N	min^{-1}	2000	3500	3500
Rated torque	M_N	Nm	15,3	16,9	43,5
Rated current	I_N	A	15,2	17,9	43
Rated power	P_N	kW	3,9	8	19,4
Rated voltage	U_N	V	148	260	276
Rated frequency	f_N	Hz	133	233	233
Mechanical parameters					
Rotor inertia	J_M	kgm^2	$273,0 \times 10^{-4}$		
Theoretical maximum torque	M_{max}	Nm	148		
Minimum strand cross-section ⁴⁾	S	mm^2	6	10	16
Thermal time constant	T_{th}	min	90	90	40
Maximum speed	n_{max}	min^{-1}	4000		
Motor mass ^{3) 5)}	m	kg	45,0		
Perm. storage and transport temp.	T_L	°C	-20 to +80		
Permissible ambient temperature ⁶⁾	T_{um}	°C	0 to 40		
Max. setup height ⁶⁾	h	m	1000 above NN		
Protection category ⁷⁾			IP65		
Insulation class (according to DIN VDE 0530 Part 1)			F		
Housing coat			Prime coat black in a/w RAL 9005		
¹⁾ K_m is to be used for calculations with crest values (I_{dN} , I_{max}). For calculations with root-mean-square values (rated data), the torque constant K_m must be multiplied by a factor of $\sqrt{2}$. ²⁾ Values determined according to EN 60034-1. Current and voltage specified as root-mean-square values. ³⁾ Use the declared value in bracket for motors holding brake. ⁴⁾ Applicable to REXROTH INDRAMAT cables. Rated according to VDE0298-4 (1992) and installation type B2 according to EN 60204-1 (1993) at an ambient temperature of 40 °C. ⁵⁾ Without blower unit. ⁶⁾ If the limits specified are exceeded, the performance data must be reduced if necessary. For reduction factors, refer to the chapter entitled "Environmental Conditions". ⁷⁾ Provided the power and encoder cables are mounted properly					

Fig. 10-7: Technical data MKD112C-058

Description	Symbol	Unit	MKD112D-027		
			Natural 60K	Natural 100K	Surface 60K /100K
Cooling mode – Motor overtemperature					
Electric parameters					
Characteristic motor speed	n_K	min^{-1}	3000		
Continuous torque at standstill	M_{dN}	Nm	48,0	57,0	72,0
Continuous current at standstill	I_{dN}	A	31,6	40,2	47,4
Peak current	I_{max}	A	142,2		
Torque constant at 20°C ¹⁾	K_m	Nm/A	1,7		
Voltage constant at 20°C	$K_{E(\text{eff})}$	V/1000min ⁻¹	154,5		
Winding resistance at 20°C	R_{12}	Ω	0,35		
Winding inductance	L_{12}	mH	5,65		
Number of pole pairs	p		4		
Rated data ²⁾					
Rated speed	n_N	min^{-1}	2000	2000	2000
Rated torque	M_N	Nm	27,3	41,5	59,2
Rated current	I_N	A	12,7	20,7	27,6
Rated power	P_N	kW	6,9	11,3	15,2
Rated voltage	U_N	V	319	331	344
Rated frequency	f_N	Hz	133	133	133
Mechanical parameters					
Rotor inertia	J_M	kgm^2	$350,0 \times 10^{-4}$		
Theoretical maximum torque	M_{max}	Nm	187		
Minimum strand cross-section ⁴⁾	S	mm^2	2,5	4	6
Thermal time constant	T_{th}	min	90	90	40
Maximum speed	n_{max}	min^{-1}	3000		
Motor mass ^{3) 5)}	m	kg	56,0		
Perm. storage and transport temp.	T_L	°C	-20 to +80		
Permissible ambient temperature ⁶⁾	T_{um}	°C	0 to 40		
Max. setup height ⁶⁾	h	m	1000 above NN		
Protection category ⁷⁾			IP65		
Insulation class (according to DIN VDE 0530 Part 1)			F		
Housing coat			Prime coat black in a/w RAL 9005		
¹⁾ K_m is to be used for calculations with crest values (I_{dN} , I_{max}). For calculations with root-mean-square values (rated data), the torque constant K_m must be multiplied by a factor of $\sqrt{2}$. ²⁾ Values determined according to EN 60034-1. Current and voltage specified as root-mean-square values. ³⁾ Use the declared value in bracket for motors holding brake. ⁴⁾ Applicable to REXROTH INDRAMAT cables. Rated according to VDE0298-4 (1992) and installation type B2 according to EN 60204-1 (1993) at an ambient temperature of 40 °C. ⁵⁾ Without blower unit. ⁶⁾ If the limits specified are exceeded, the performance data must be reduced if necessary. For reduction factors, refer to the chapter entitled "Environmental Conditions". ⁷⁾ Provided the power and encoder cables are mounted properly					

Fig. 10-8: Technical data MKD112D-027

Holding Brake

Description	Symbol	Unit	Holding brake 1	Holding brake 2	Holding brake 3
Motortype			MKD112A MKD112B		MKD112C MKD112D
Holding torque	M_4	Nm	22,0	32,0	70,0
Rated voltage	U_N	V	DC 24 ± 10%	DC 24 ± 10%	DC 24 ± 10%
Rated current	I_N	A	0,71	0,93	1,29
Moment of inertia	J_B	Kgm ²	$3,6 \times 10^{-4}$	$12,42 \times 10^{-4}$	30×10^{-4}
Clamping delay	t_1	ms	25	15	53
Release delay	t_2	ms	50	115	97
Mass	m_B	kg	1,1	2,4	3,8

Fig. 10-9: Technical data of holding brake MKD112 (option)

10.2 Type code – Ordering Name

Abbrev. Column	1	2	3	4	5	6	7	8	9	0	1	2	3	4	5	6	7	8	9	0	2	3	4	5	6	7	8	9	0	3	4	5	6	7	8	9	0	4
Example:	M	K	D	1	1	2	B	-	0	4	8	-	G	G	0	-	A	N																				

1. Product
1.1 MKD..... = MKD

2. Motor size
2.1 112..... = 112

3. Motor length
3.1 Lengths..... = A, B, C, D

4. Windings code
4.1 MKD112A..... = 024, 058
4.2 MKD112B..... = 024, 048, 058
4.3 MKD112C..... = 024, 058
4.4 MKD112D..... = 027

5. Motor encoder
5.1 Resolver feedback..... = G
5.2 Resolver feedback with integrated multiturn absolute encoder..... = K

6. Driven shaft
6.1 plain shaft (with shaft sealing ring)..... = G
6.2 Shaft with key per DIN 6885-1 (with shaft sealing ring)..... = P

7. Holding brake ①
7.1 without holding brake..... = 0
7.2 with holding brake 22 Nm..... = 1
7.3 with holding brake 32 Nm..... = 2
7.4 with holding brake 70 Nm..... = 3

8. Output direction of power connection ②
8.1 Connector to side A..... = A
8.2 Connector to side B..... = B
8.3 Connector to the left..... = L
8.4 Connector to the right..... = R

9. Other design
9.1 none..... = N

10. Standard reference

Standard	Title	Edition
DIN 6885-1	Drive Type Fastenings without Taper Action; Parallel Keys, Keyways, Deep Pattern	1968-08

Note:
① Holding brake "1" and "2" only available with motor length "A" and "B"
Holding brake "3" only available with motor length "C" and "D"
② Looking from front onto driven shaft (see picture 1)

Illustration example: MKD112

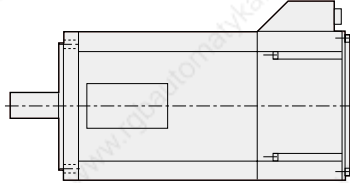

Position of power connection = top

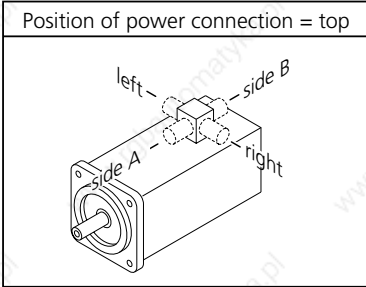

Picture 1
INN-41-65-T11-02-M12-MKD2.EPS

Fig. 10-10: MKD112 type code

10.3 Speed – Torque – Characteristics

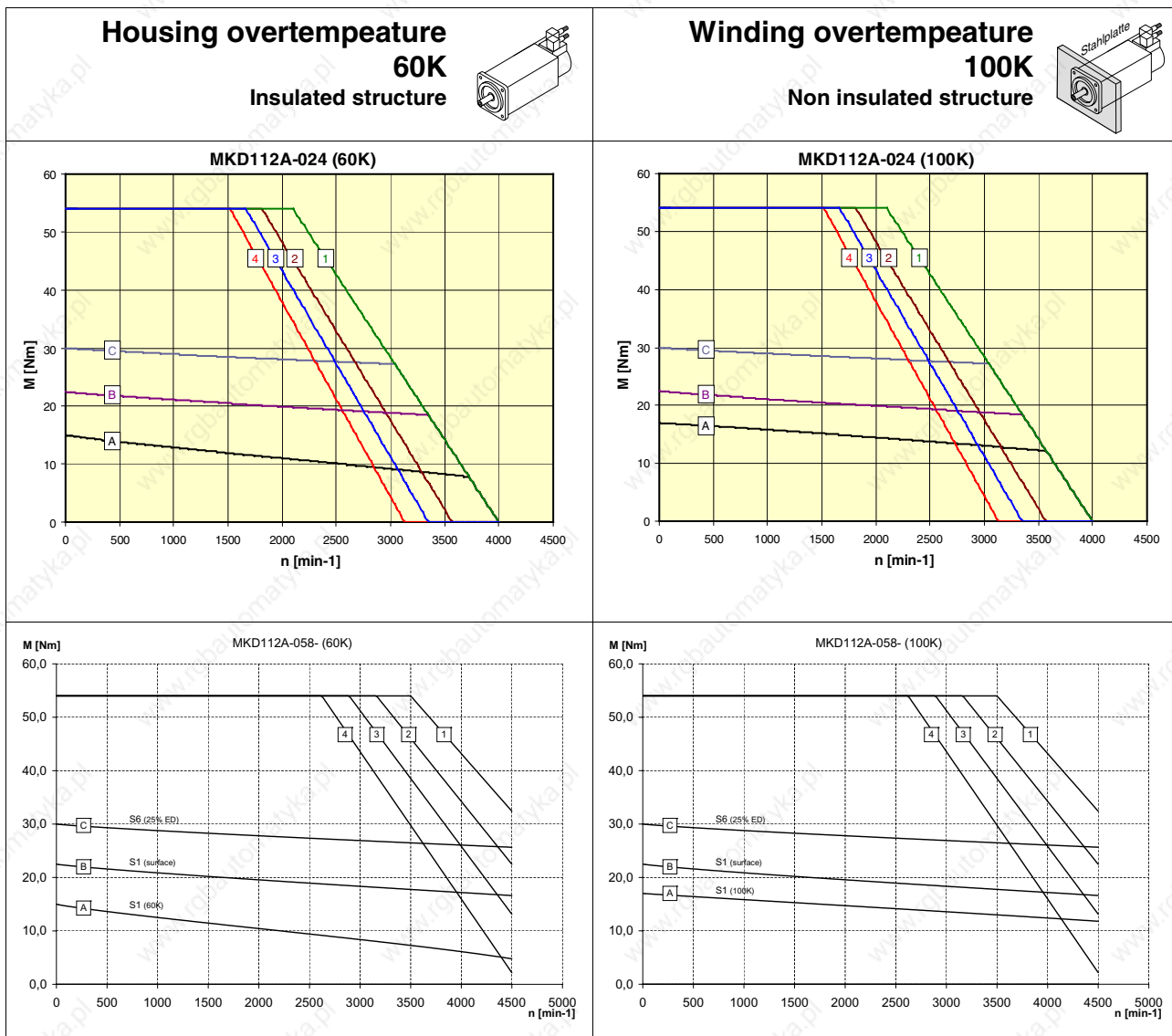

- [A]: M_{dN} Natural conv. (S1 continuous operation)
- [B]: M_{dN} Surface cooling (S1 continuous operation)
- [C]: M_{KB} (S6 intermittent operation)
- [1]: HDS to HVR
- [2]: HDS to HVE or DKCxx.3 with a power connection of 3x AC 480V
- [3]: HDS to HVE or DKCxx.3 with a power connection of 3x AC 440V
- [4]: HDS to HVE or DKCxx.3 with a power connection of 3x AC 400V

Fig. 10-11: Speed – torque – characteristics

Housing overtemperature 60K
Insulated structure

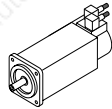

Winding overtemperature 100K
Non insulated structure

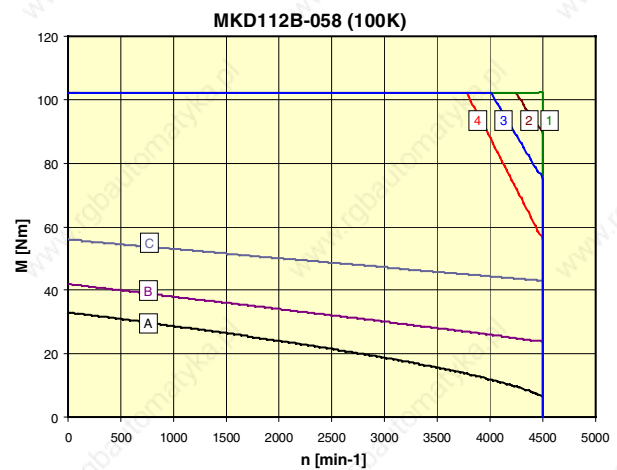
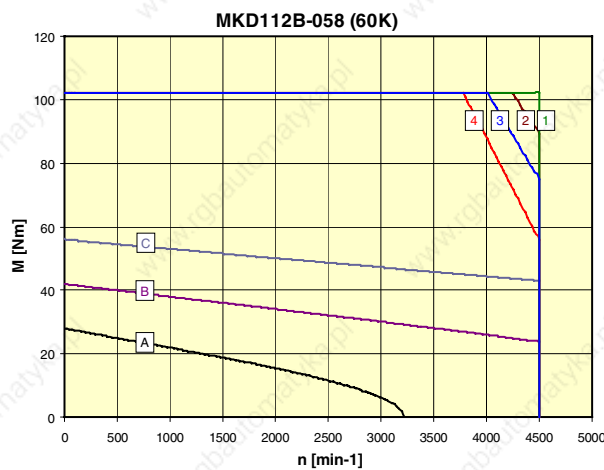
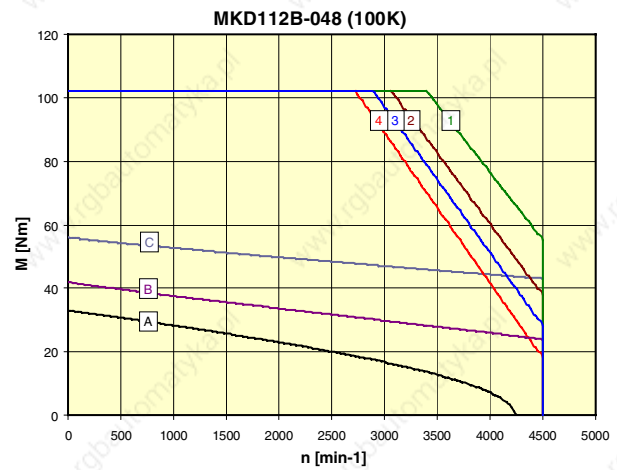
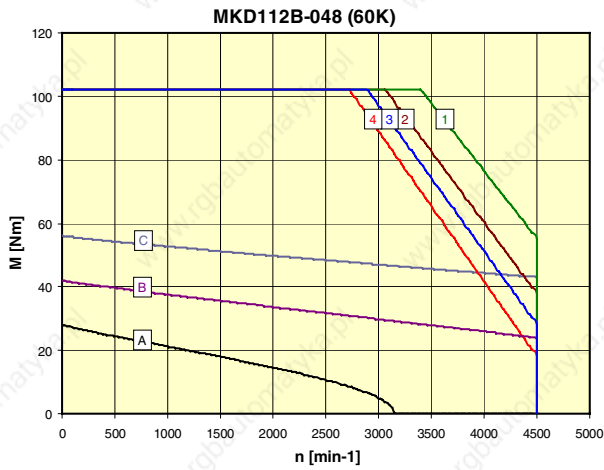
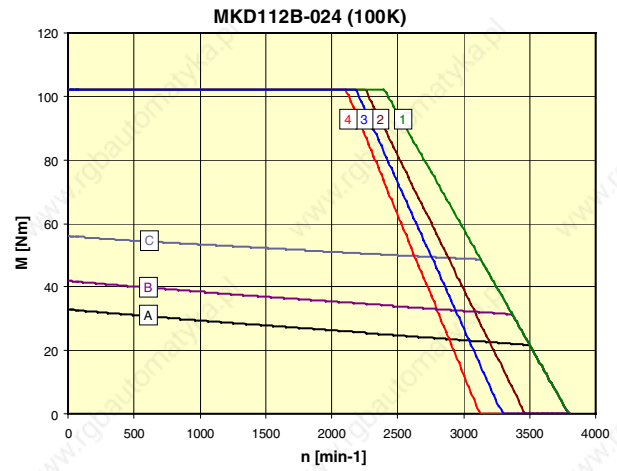
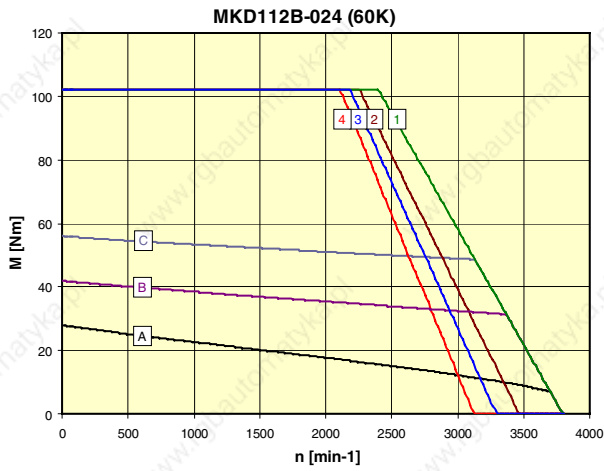
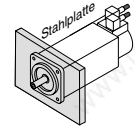

- [A]: M_{dN} Natural conv. (S1 continuous operation)
- [B]: M_{dN} Surface cooling (S1 continuous operation)
- [C]: M_{kB} (S6 intermittent operation)
- [1]: HDS to HVR
- [2]: HDS to HVE or DKCxx.3 with a power connection of 3x AC 480V
- [3]: HDS to HVE or DKCxx.3 with a power connection of 3x AC 440V
- [4]: HDS to HVE or DKCxx.3 with a power connection of 3x AC 400V

Fig. 10-12: Speed – torque – characteristics

Housing overtemperature 60K
Insulated structure

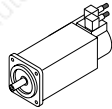

Winding overtemperature 100K
Non insulated structure

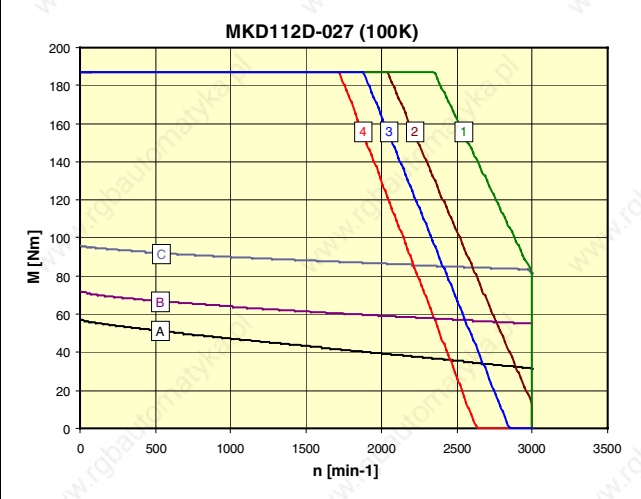
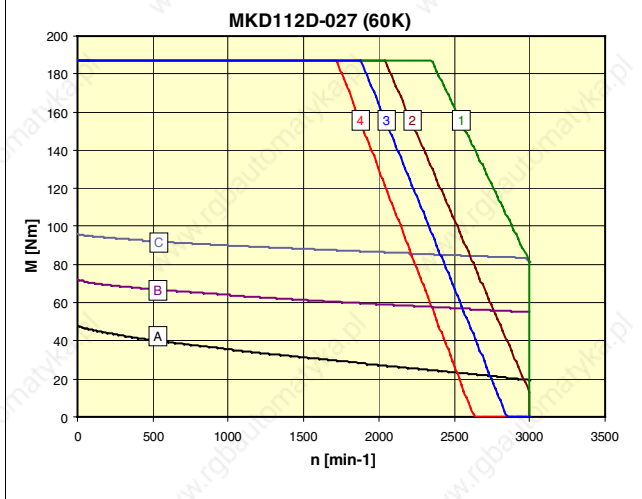
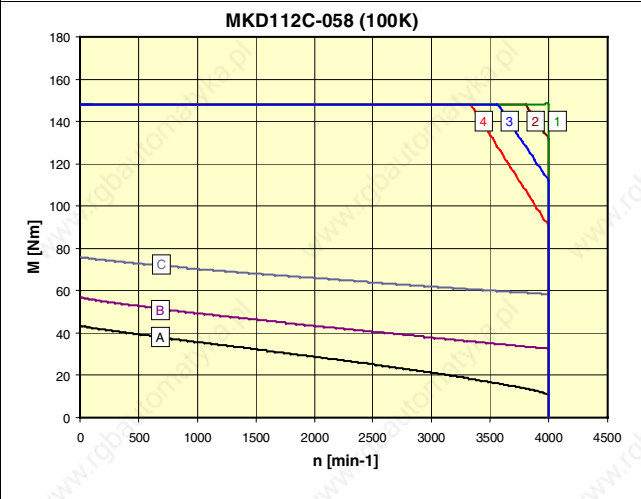
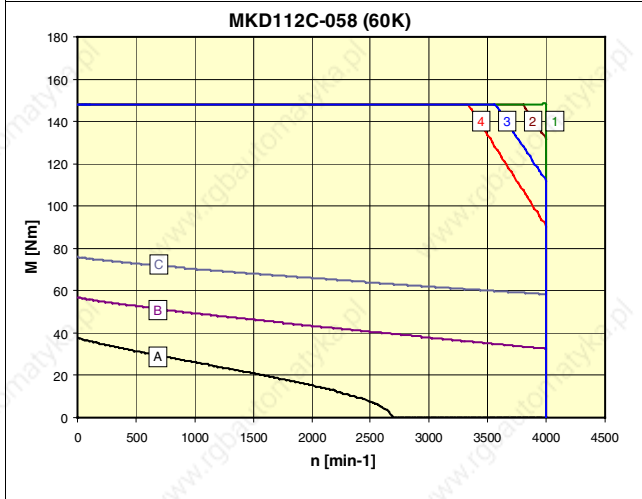
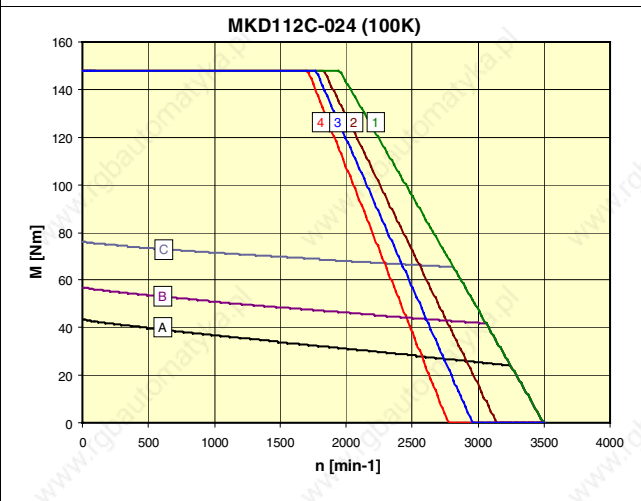
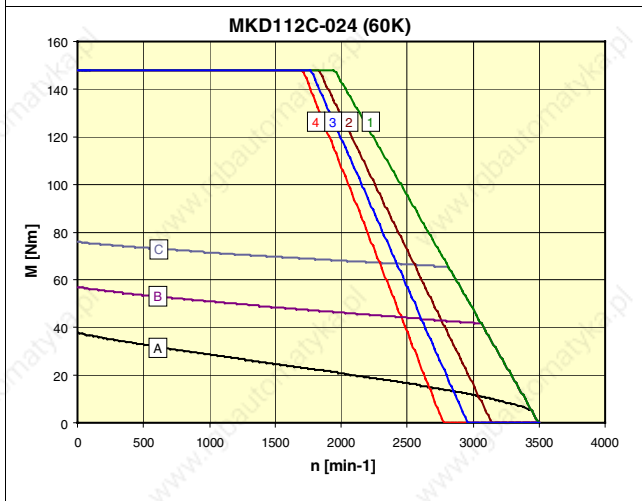
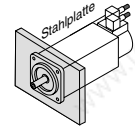

- A): M_{dN} Natural conv. (S1 continuous operation)
- [B]: M_{dN} Surface cooling (S1 continuous operation)
- [C]: M_{kB} (S6 intermittent operation)
- [1]: HDS to HVR
- [2]: HDS to HVE or DKCxx.3 with a power connection of 3x AC 480V
- [3]: HDS to HVE or DKCxx.3 with a power connection of 3x AC 440V
- [4]: HDS to HVE or DKCxx.3 with a power connection of 3x AC 400V

Fig. 10-13: Speed – torque – characteristics

10.4 Shaft Load

Permissible maximum radial force $F_{\text{radial_max}}$ and permissible radial force F_{radial}

For explanations refer to page 13-12.

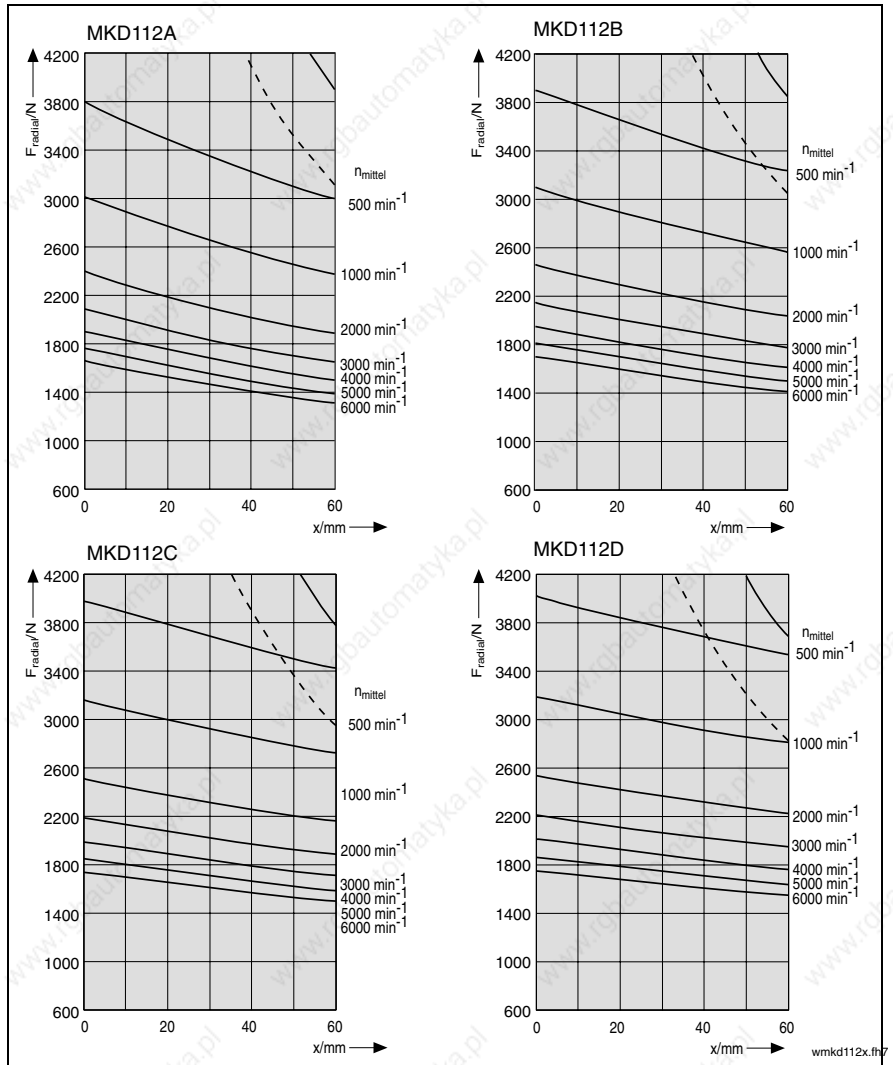

- (1): $F_{\text{radial_max}}$ (plain shaft)
- (2): $F_{\text{radial_max}}$ (shaft with keyway)

Fig. 10-14: MKD112: Permissible maximum radial force $F_{\text{radial_max}}$ and permissible radial force F_{radial}

Permissible axial force F_{axial}

$$F_{\text{axial}} = x \cdot F_{\text{radial}}$$

- x: **0,36** for MKD112A, -B
- x: **0,35** for MKD112C, -D
- F_{axial} : permissible axial force in N
- F_{radial} : permissible radial force in N

Fig. 10-15: MKD112: permissible axial force F_{axial}

10.5 Dimensions

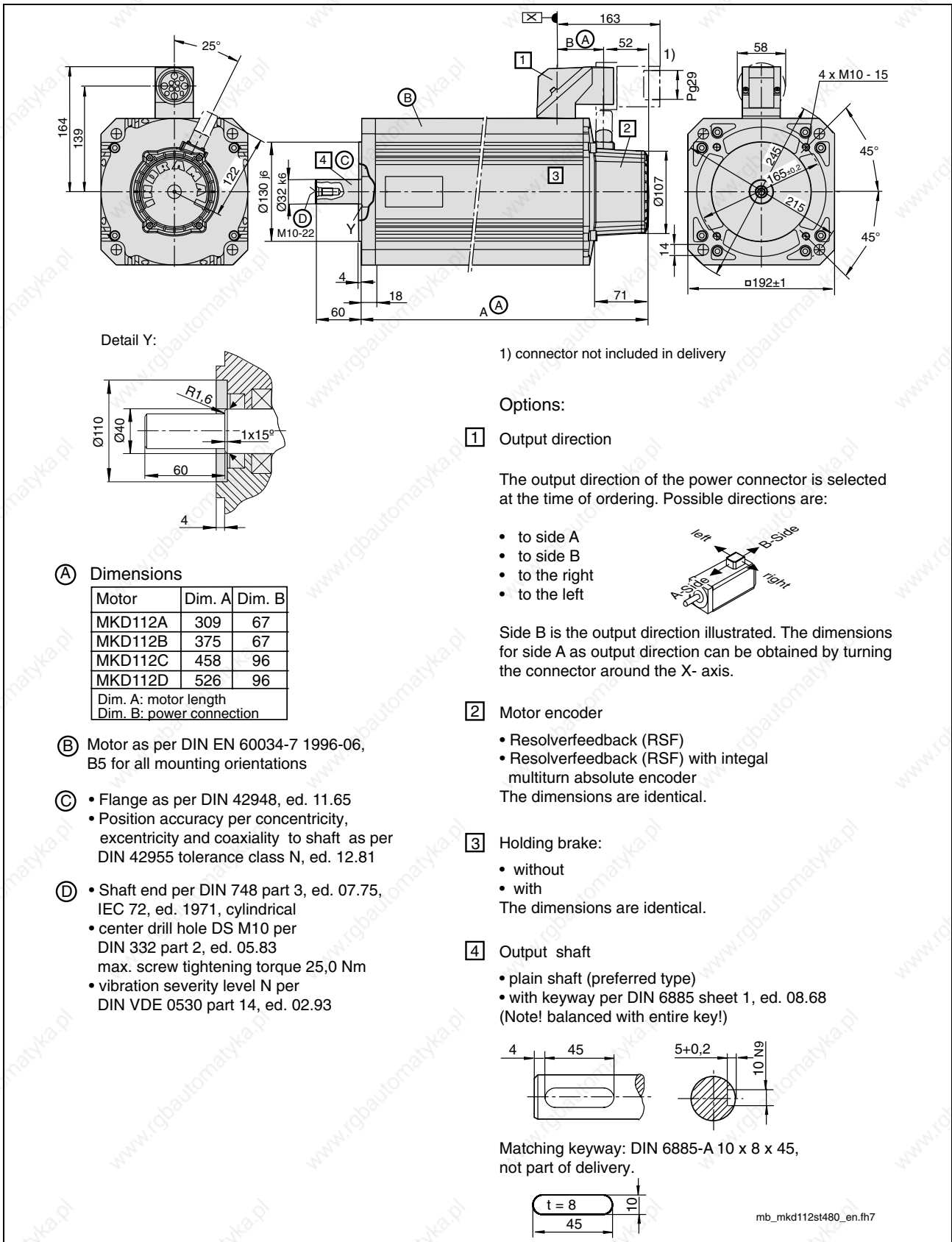

Fig. 10-16: Dimensional data MKD112A, MKD112B, MKD112C ¹⁾, MKD112D
1) not applicabel to MKD112C-058

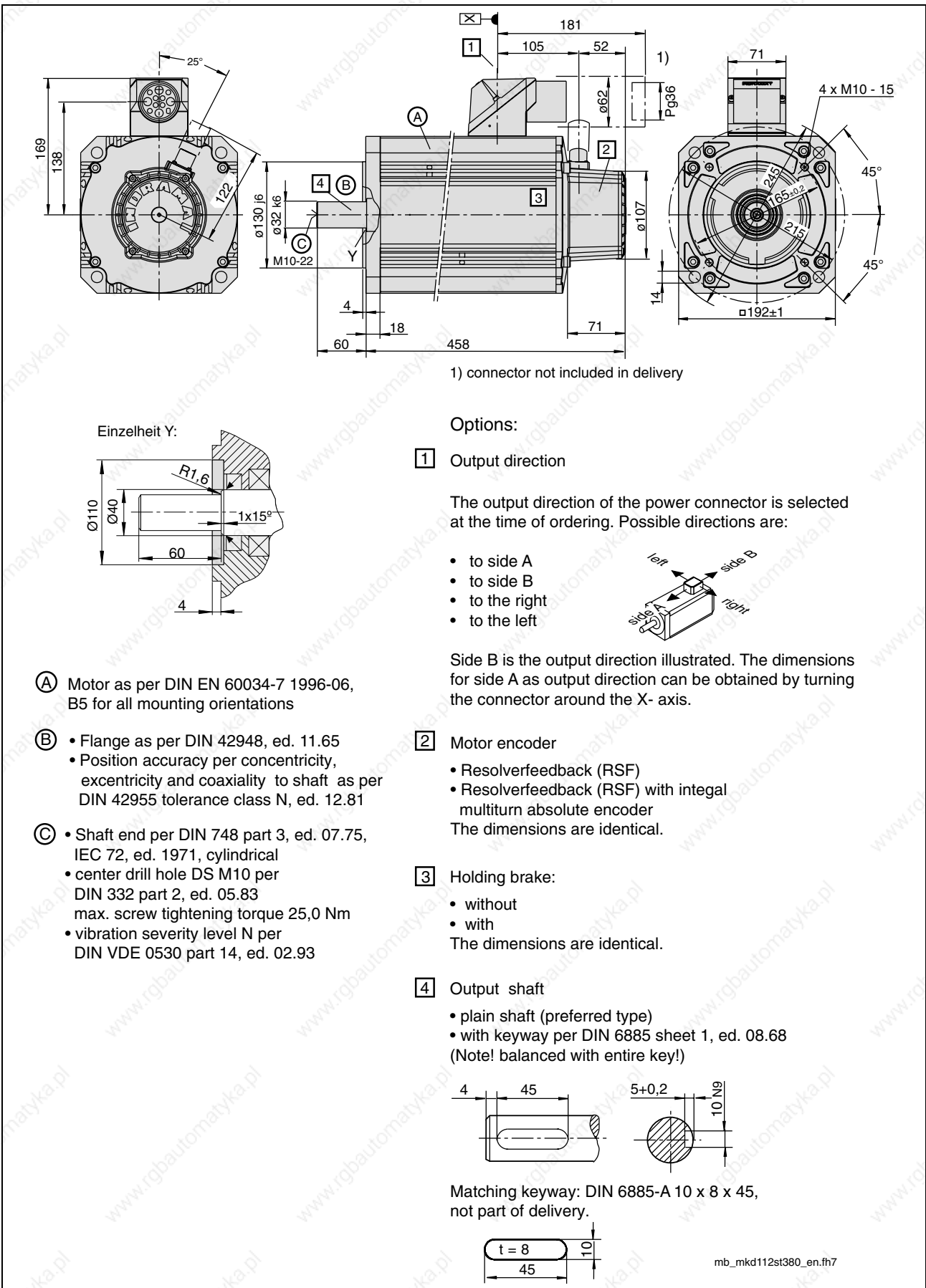

Fig. 10-17: Dimensional data MKD112C-058

10.6 Blower Units

MKD motors can also be delivered with optional blower units. Please refer to the „Surface“ column of the data sheets for performance data of surface-cooled motors. The mechanical dimensions of the blower units are represented in the dimension drawings. The possibilities of combining motor and blower unit and the technical data of the blowers are represented in the table below.

Motor			Ordering name of blower unit			
			LEM – RB112C1XX	LEM – RB112C2XX	LEM – AB112X121	LEM – AB112X221
MKD112A			---	---	x	x
MKD112B, -C, -D			x	x	x	x
--- Blower installation not possible; x Blower installation possible						

Technical data of blower unit			LEM – RB112C1XX	LEM – RB112C2XX	LEM – AB112X121	LEM – AB112X221
Description	Symbol	Einheit				
Type of cooling			radial		axial	
Air flow			B A blowing		B A blowing	
Rated voltage	U_n	V	230V, ± 15% 50 / 60Hz	115V, ± 10% 50 / 60Hz	230V, ± 15% 50 / 60Hz	115V, ± 10% 50 / 60Hz
Rated power	P_n	W	45 / 43	40 / 39	45 / 43	40 / 39
Rated current	I	A	0,31 / 0,25	0,53 / 0,46	0,31 / 0,25	0,53 / 0,46
Mean air volume	V	m ³ /h	340	390	340	390
Blower unit mass	m_L	kg	1,2	1,1	1,2	1,1
Noise level		dB(A)	48 / 52	48 / 52	48 / 52	48 / 52

Fig. 10-18: Technical data of MKD112 blower units (optional)

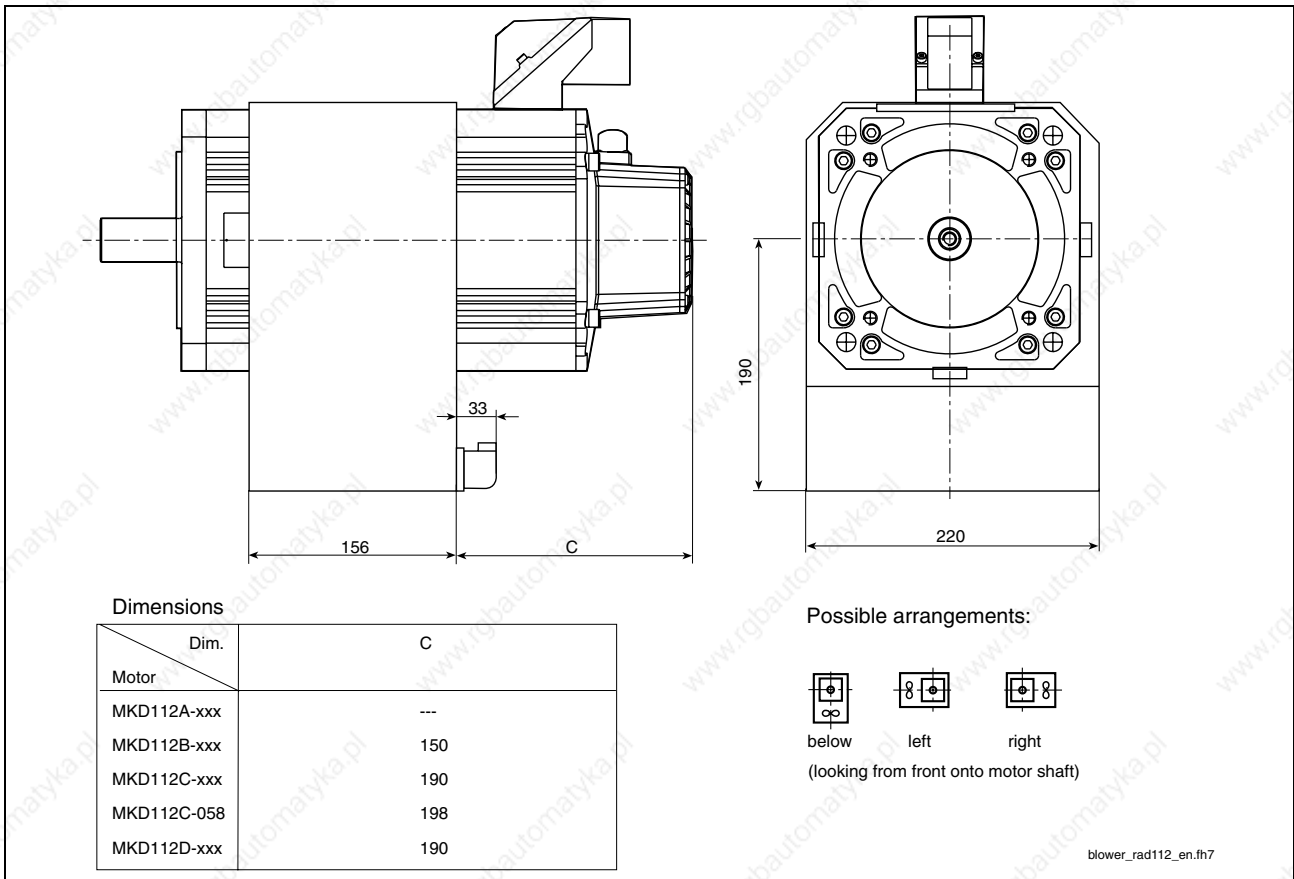

Fig. 10-19: Dimensional data MKD112 with radial blower

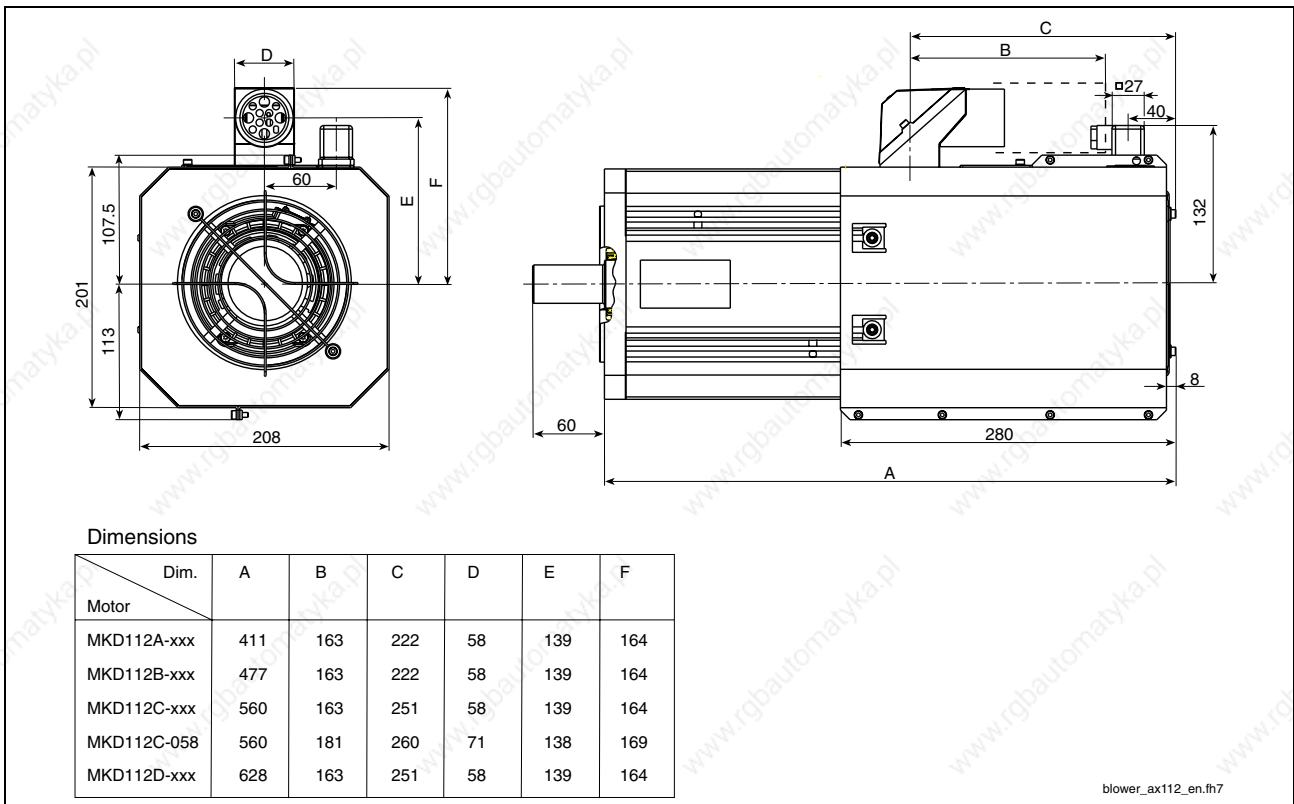

Fig. 10-20: Dimensional data MKD112 with axial blower

11 Accessories

11.1 Sealing Air Connection Accessories

Option Sperrluftanschluss Sealing air connectors are available for MKD motors. They are attached to the motor by simply replacing the motor flange socket cover. A defined overpressure inside the motor prevents reliably the income of liquids e.g. cooling liquid and lubricants.



Abb. 11-1:MKD sealing air connector

Note: When mounting the motor flange socket covers with sealing air connector, ensure that the O-rings are properly seated. The degree of protection required is ensured only with correct assembly.

order types of the sealing air connectors

The motor flange socket covers available with sealing air connector are listed in the table below.

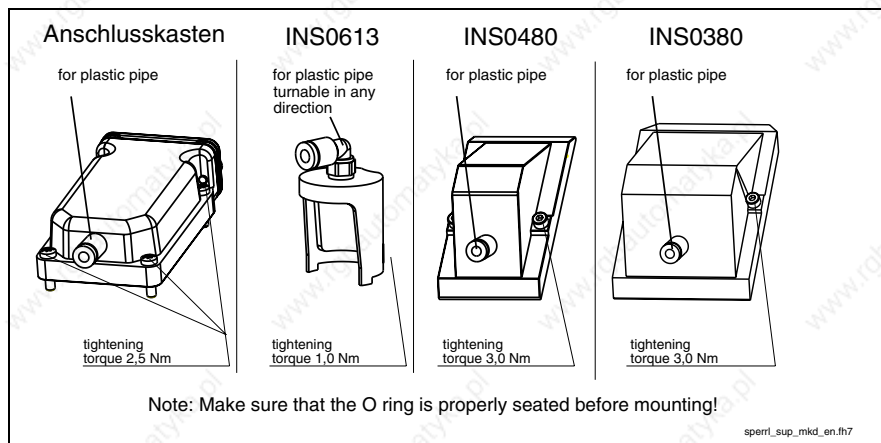
motor connection option	Description	Motor
connection box	SUP-M01-MKD	MKD025 MKD041 MKD071 MKD090
INS0480 (power connector)	SUP-M01-MHD	MKD112
INS0380 (power connector)	SUP-M02-MHD	MHD112C-058
INS0613 (feedback connector)	SUP-M03-MHD	MKD025

Fig. 11-2 Sealing air connector accessories

Note: A numbering description of the sealing air connector accessories with instructions, notes for selection and application conditions are available under the following order type. DOK-MOTOR*-PROTC*SERVO-IF02-EN-P

11.2 Gearings

GTS, GTP Planetary Gearings

Planetary gearings for the

- GTS and
- GTP

series are suitable for being attached to MKD motors and can be obtained from Rexroth.

The planetary gearings are characterized by the following features:

High operational reliability

- Low-maintenance operation owing to lifetime lubrication
- Use under adverse environmental conditions is possible (owing to the completely closed design in IP 65 degree of protection)

High performance data

- Low-play gear teeth with minimum reverse play owing to ground gear pairs
- High torsional strength owing to load distribution to three planetary wheels
- High efficiency owing to planetary wheel principle
- High dynamics owing to low masses of inertia
- Low weight owing to compact design

Easy attachment to machine

- Direct overhung mounting of pinions and belt pulleys, owing to the bearing being designed for high permissible radial loads
- Flange design permitting attachment according to design B5 (DIN 42959, Part 1, ed. 08.77) with hole in the flange

The output shaft can be mounted in two different ways:

- friction-locked shaft-hub connection by means of a plain shaft, or
- friction-locked shaft-hub connection by means of an output shaft with keyway.

Note:

- Refer to the documentation DOK-GEAR**-GTS*****-PR06-EN-P for a detailed description of the GTS planetary gearings.
 - Refer to the documentation DOK-GEAR**-GTP*****-PRJ1-EN-P for a detailed description of the GTP planetary gearings.
-

Worm Gears 058

- Field of application** Worm gears of the
- 58... series are suitable for being attached to MKD motors and are characterized by the following features:
- High operational reliability**
- Low-maintenance operation owing to oil lubrication
 - Use under adverse environmental conditions is possible (owing to the completely closed design in IP 65 degree of protection)
- High performance data**
- Low-play gear teeth readjustable during operation, owing to ground gear pairs
 - Low noise development owing to worm gear principle
 - High dynamics owing to low masses of inertia
 - Low weight owing to housing components made of aluminum
- Easy attachment to machine**
- Direct overhung mounting of pinions and belt pulleys, owing to the bearing being designed for high permissible radial loads
 - The output elements can be mounted in two different ways:
 - friction-locked shaft-hub connection by means of a plain output hollow shaft, or
 - friction-locked shaft-hub connection by means of an output hollow shaft with keyway
 - The housing design of the gear permits attachment to the machine in very many ways.

Note: Refer to the documentation DOK-GEAR**--58*WORMGEAR-PRJ1-EN-P for a detailed description of the 58... worm gears.

Notes

12 Connection System

12.1 Overview of Connections

The electric connections of Rexroth drives are standardized. The MKD AC motors are provided with

- a power connector, incl. connection for temperature sensor and holding brake,
- an encoder connection (feedback connector).

Both connections depend of the motor type, wether as connection box or as a separate plug-in connector.

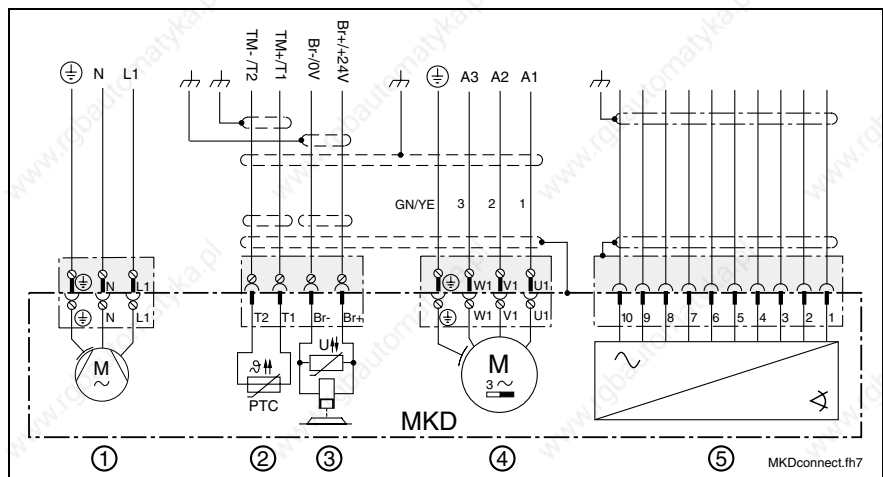

(1): **Blower**

blower units can be attached optionally on MKD motors. Blower units are working independent from the drive controller. Blower cables and protective circuit breakers are not in the scope of delivery of REXROTH INDRAMAT.

(2): **Temperature sensors**

Temperature sensors (PTC) are fixed-mounted in the motor windings. The measurement data evaluation is occured over the drive controller.

(3): **Holding brake**

The optional holding brake can be triggered over an external control (SPS) or with an appropriate drive controller.

(4): **Power connector**

Standard version as connector box, on motor type 112 as plug-in connector. For type 025 connectors can also be delivered alternatively.

(5): **Encoder connection**

Standard version as connector box, on motor type 112 as plug-in connector. For type 025 connectors can also be delivered alternatively.

Fig. 12-1: MKD Connection diagram: overview

12.2 Motors with connector box

Connection diagram

Note: Here is only the direct connection between motor and drive controller described. The connection diagrams are also guilty for all other connections (e.g. with intermediate connection). There is no change with coordinating the motor and drive controller connections.

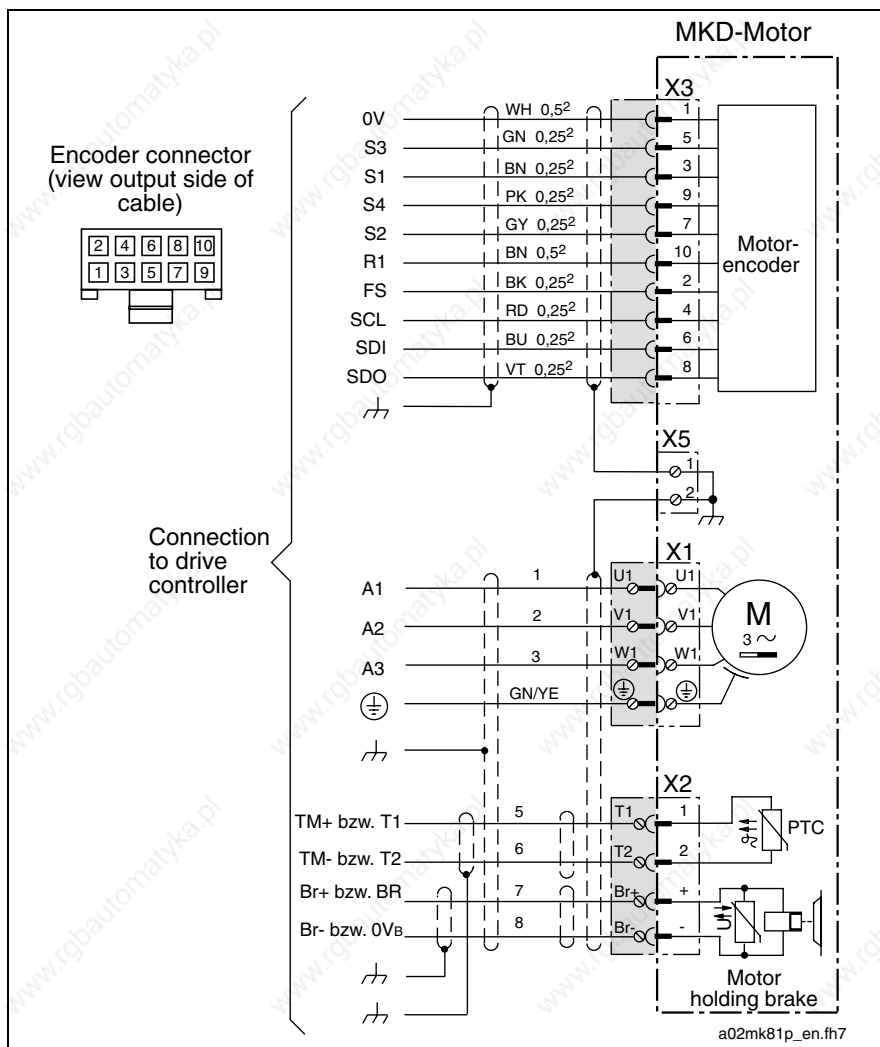

Fig. 12-2: " MKD-motor with connector box.

Cables are not included in the scope of delivery of the motors and must be ordered as separate items.

Deliverable motors with
connector box

Motor		Power and encoder connection
MKD	Winding	
MKD025A	144	connection box
MKD025B	144	
MKD041A	144	
MKD041B	144	
MKD071A	061	
MKD071B	035	
MKD071B	061	
MKD090B	035	
MKD090B	047	
MKD090B	058	

Fig. 12-3: MKD with connection box

12.3 Motors with connector receptacle

Connection diagram

Note: Here is only the direct connection between motor and drive controller described. The connection diagrams are also guilty for all other connections (e.g. with intermediate connection). There is no change with coordinating the motor and drive controller connections.

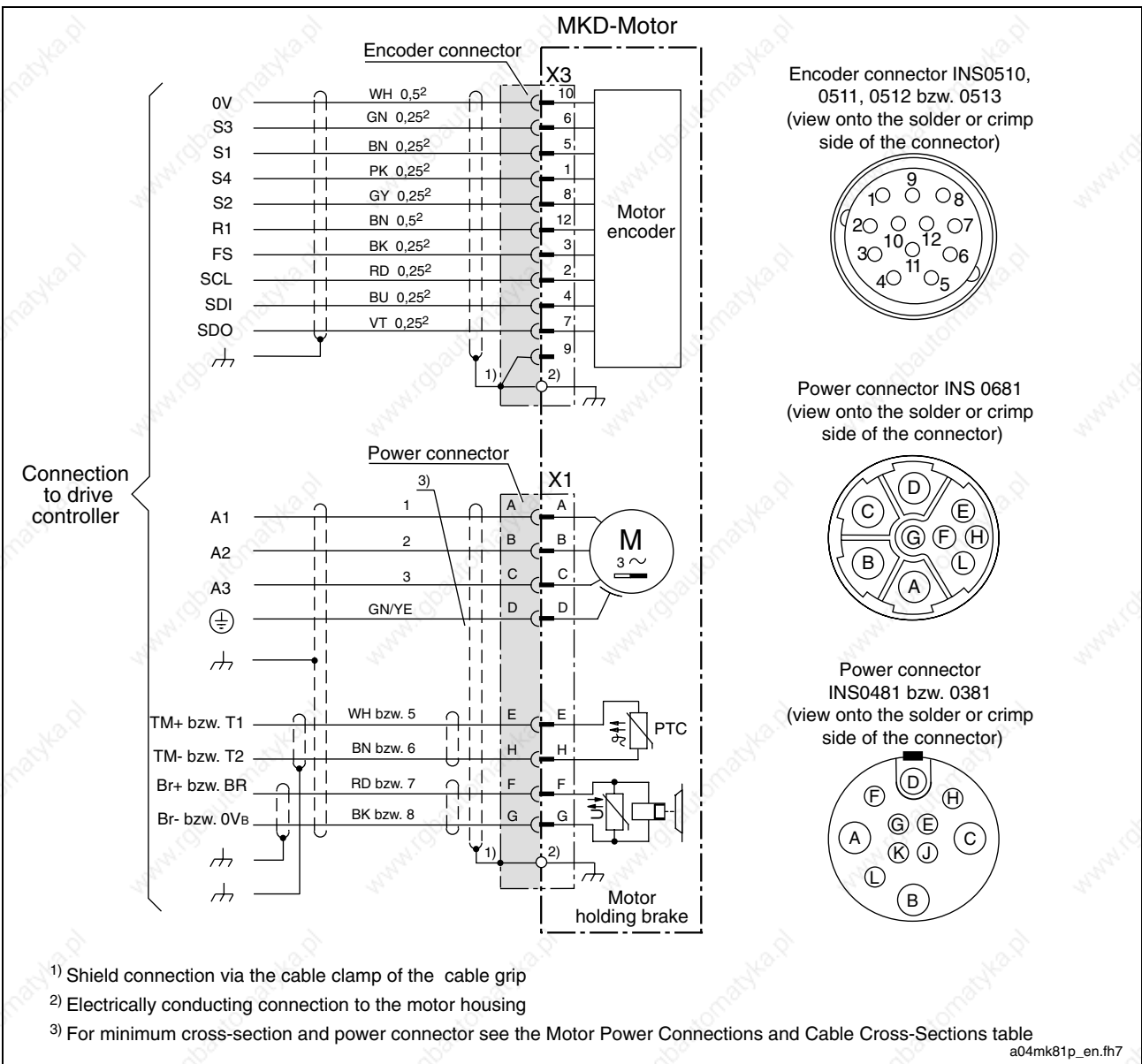

Fig. 12-4: MKD-motor with connector receptacle

Plugs and cables are not included in the scope of delivery of the motors and must be ordered as separate items.

Deliverable motors with flange socket

Motor		Connection/flange socket	Appropriate plug
MKD	Winding		
MKD025A	144	INS0680	INS0681
MKD025B	144		
MKD112A	024	INS0480	INS0481
MKD112A	035		
MKD112A	058		
MKD112B	024		
MKD112B	035		
MKD112B	048		
MKD112B	058		
MKD112C	024		
MKD112C	035		
MKD112D	027		
MKD112C	058	INS0380	INS0381

Fig. 12-5: MKD with connector receptacle

Power connector flange socket

View on the mating side of the flange sockets

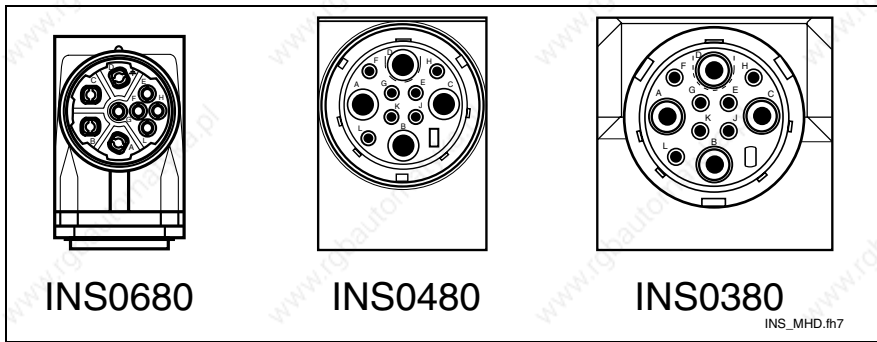

Fig. 12-6: MKD flange sockets

Flange socket	INS0680	INS0480	INS0380	Description
Power supply contacts	A,B,C	A,B,C	A,B,C	U1, V1, W1
PE contact	D	D	D	
Temp. sensor contacts	E,H	E,H	E,H	T1, T2
Brake contact	F,G	F,G	F,G	Br+, Br-
Unused contacts	L	J,K,L	J,K,L	

Fig. 12-7: Pin assignment of flange socket for the MKD power connector

Encoder connection flange sockets

Please refer to the overview of connectors for the assignment of the encoder signals and the pin assignment of the flange socket.

Flange socket	INS0514 INS0524 INS0613	Description
Contacts	1, 2, 3, 4, 5, 6, 7, 8, 10	See overview of connectors
Unused contacts	9, 11	

Fig. 12-8: Pin assignment of flange socket for the MKD encoder connection

12.4 Blower connector

MKD motors can be supplied optionally with axial or radial blower. The various connection possibilities are described in the table below. Please refer to the technical data for the fan units available.

MKD	Power connection	Blower	Direction	Blower connection	Type of connection	Supply voltage
071 090	Flange socket	Radial	B > A (blowing)	Flange socket + plug	(1)	230 V AC, 115 V AC ±10%, 50...60 Hz
112	Flange socket	Axial	B > A (blowing)	Flange socket + plug	(1)	
		Radial	B > A (blowing)	Flange socket + plug	(1)	

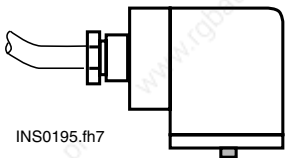

(1)

INS0195.fh7

Index (1) connector type is used for explanation in this chapter. Please observe the examples below.

Fig. 12-9: Table of MKD blower connections

Note: To establish the connection, the fan plug must be opened and closed.

- The electric connection may be established by qualified technical personnel only. Please observe the safety instructions.
- The housing tightness may not be reduced.

Type (1)

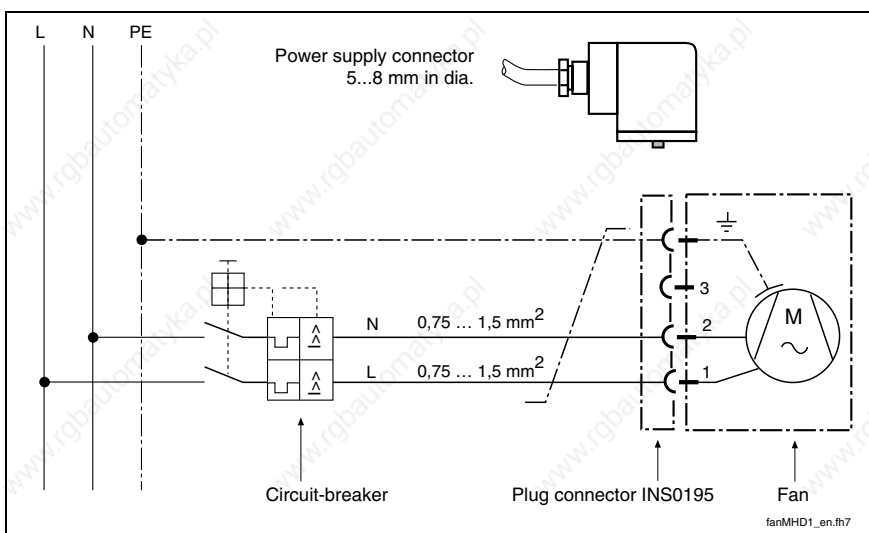
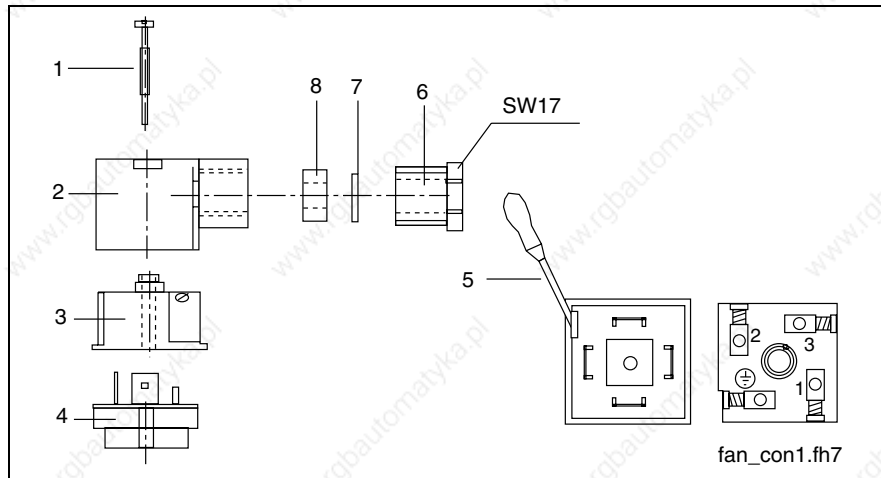

Fig. 12-10: Blower connection diagram type (1)

Connecting and mounting the blower

Electric connection A three-core cable with a connection cross-section of at least 0.75 mm^2 must be used as connection cable.



- (1): Housing screw
- (2): Plug housing
- (3): Plug insert
- (4): Flange socket
- (5): Screwdriver
- (6): Heavy-gauge conduit thread
- (7): Washer
- (8): Seal

Fig. 12-11: Blower connector type (1)

Proceed as follows to mount the connection cable to the fan plug:

1. Loosen the heavy-gauge conduit thread (6) (size 17).
2. Turn the cylinder screw (1) out of the socket (4) using the screwdriver (5).
3. Pull off the plug housing (2) including the plug insert (3) from the flange socket (4).
4. Pull out the cylinder screw (1).
5. Remove the plug insert (3) from the plug housing (2) (see Fig. 15-8).
6. Push the heavy-gauge conduit thread (6), the washer (7), the seal (8), and the plug housing (2) onto the connection cable ($3 \times 0.75 \text{ mm}^2$).
7. Strip the outer sheath of the cable for approx. 20 mm, litz wires for 10 mm, and connect it to the plug insert (3) as illustrated above.
8. Push the plug insert (3) into the plug housing (2); fit the cylinder screw (1); screw the plug to the socket (4).
9. Tighten the heavy-gauge conduit thread (6), while ensuring strain relief.

12.5 Connection Cable

Dimensioning of power cable

The specified and calculated cross sectional area of the cables in this Rexroth Indramat documentation base on RMS current and the assumption for "rotating motors". Base for this calculation are the specified stillstand-constant current in the technical data. They are specified as peak values.

The relevant electric currents are in association as follows:

"rotating motor"

$$I_{(\text{Kabel})} = \frac{I_{dN(\text{Motor})}}{\sqrt{2}}$$

$I_{(\text{cable})}$ relevant electric current to dimensioning for the cable
 $I_{dN(\text{Motor})}$ Stillstand-constant current motor (peak values)

Fig. 12-12: RMS – and peak values ("rotating motor")

Generally is the dimensioning after RMS current at a "rotating motor" sufficient.

"motor at standstill"

$$I_{(\text{Kabel})} = I_{dN(\text{Motor})}$$

$I_{(\text{cable})}$ relevant electric current to dimensioning for the cable
 $I_{dN(\text{Motor})}$ Stillstand-constant current motor (peak values)

Fig. 12-13: RMS – and peak values ("motor at stillstand")

In some cases, applications, working over a longer period, require a continuous torque at standstill when speed = 0 min⁻¹ for the motors (standard value see Fig. 12.14) is recommended to manage the cable-dimensioning as specified peak values in the technical datas ("standstill motor").

Motor type	period
MKD025	10 min
MKD041, 071, 090, 112	15 min

Fig. 12-14: Working over a longer period

Note: The specified, recommended minimum cross sections is to be checked by the machine/system manufacturer for the machine/system-specific conditions and, if necessary, corrected.

Selection of connection cable

Rexroth deliver finished power and encoder cable sets. The following documentation contains:

- an overview of the cable types available.
- technical data of the various cables,
- general installation regulations for Rexroth cables.

Ordering name DOK-CONNEX-CABLE*STAND-AUxx-EN-P

Material number: R911280894

Note: This documentation is an overview to select motor power cables added.

13 Application Instructions

13.1 Operating Conditions

Setup Height and Ambient Temperature

Nominal data The performance data specified for the motors apply in case of the following conditions:

- Ambient Temperature of 0 °C up to +45 °C
- Setup Height 0 m up to 1000 m above MSL.

Exceeding the nominal data Derating curves If you intend to use motors above these ranges, you must take the "utilization factors" into consideration. This reduces the performance data.

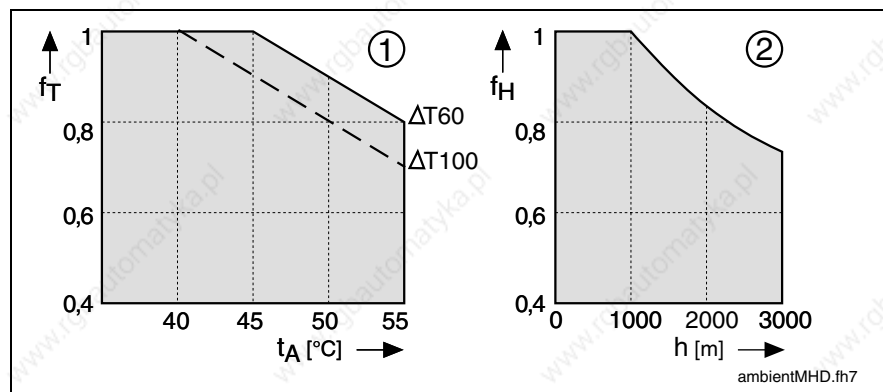

- (1): Utilization depending on the ambient temperature
 (2): Utilization depending on the setup height
 f_T : Temperature utilization factor
 t_A : Ambient temperature in degrees Celsius
 $\Delta T60 / \Delta T100$: Mode of operation
 f_H : Height utilization factor
 h : Setup height in meters

Fig. 13-1: MKD derating (utilization factors)

If **either** the ambient temperature **or** the setup height is exceeding the nominal data:

1. Multiply the torque data specified in the selection data by the utilization factor.
2. Ensure that the reduced torque data are not exceeded by your application.

If **both** the ambient temperature **and** the setup height are exceeding the nominal data:

1. Multiply the determined utilization factors f_T and f_H by each other.
2. Multiply the value obtained by the motor torque data specified in the selection data.
3. Ensure that the reduced torque data are not exceeded by your application.

Vibration and Shock Loads

MKD motors can carry loads, such as are typically occurring in case of presses, punches, or press inlets, only if they are attached in a shock-absorbed or shock-decoupled way. The construction of such attachments must be checked in isolated cases.

According to IEC 721-3-3 ed. 1987 and EN 60721-3-3 ed. 06/1994, MKD motors, if used stationary and weather-resistant, may be operated under the following conditions:

- Longitudinal motor axis: according to class 3M1
- Transverse motor axis: according to class 3M4

⇒ Ensure that the limits specified in Fig. 13-2 and Fig. 13-3 for storage, transport, and operation of the MKD motors are not exceeded.

Influencing quantity	Unit	Maximum value in longitudinal axis	Maximum value in transverse axis
Amplitude of the excursion at 2 to 9 Hz	mm	0,3	3,0
Amplitude of the acceleration at 9 to 200 Hz	m/s ²	1	10

Fig. 13-2: Limits for sinusoidal vibrations

Influencing quantity	Unit	Maximum value in longitudinal axis	Maximum value in transverse axis
Total shock-response spectrum (according to IEC721-1, :1990; Table 1, Section 6)		Type L	type I
Peak acceleration	m/s ²	40	100

Fig. 13-3: Limits for shock load

Note: MHD motors have higher maximum values.

Note: Motors with attached blowers are **not suitable** for applications subjected to shock loads, such as are occurring in case of

- punches,
- presses, or
- loading portals.

In such cases, motors without surface-cooling and a higher torque must be used.

13.2 Degree of protection

The type of protection is defined by the identification symbol IP (International Protection) and two characteristic numerals specifying the degree of protection.

The **first characteristic numeral** defines the degree of protection against contact and penetration of foreign particles. The **second characteristic numeral** defines the degree of protection against water.

First characteristic numeral	Degree of protection
6	Protection against penetration of dust (dust-proof); complete shock protection
4	Protection against penetration of solid foreign particles, more than 1 mm in diameter
2	Protection against penetration of solid foreign particles, more than 12 mm in diameter ⇒ Keep away fingers or similar objects!
Second characteristic numeral	Degree of protection
7	Protection against harmful effects if temporarily immersed in water
5	Protection against a water jet from a nozzle directed against the housing from all directions (jet water)
4	Protection against water splashing against the housing from all directions (splashwater)

Fig. 13-4: IP degrees of protection



Tests regarding the second characteristic numeral must be performed using fresh water. If cleaning is effected using high pressure and/or solvents, coolants, or penetrating oils, it might be necessary to select a higher degree of protection.

The design of the MKD motors complies with the following degrees of protection according to DIN VDE 0470, Part 1, ed. 11/1992 (EN 60 529):

Motor ranges	Degree of protection	Remark
Motor housing, output shaft, power and feedback connectors (if mounted properly only)	Approx. IP 67	If fitted with the optional sealing air connection
Motor housing, output shaft, power and feedback connectors (if mounted properly only)	IP 65	Standard design
Blower motor	IP 44	Standard design
Surface-cooling (blower grille) and blower connection	IP 24	Standard design

Fig. 13-5: Ranges of IP degrees of protection for the motors

Option sealing air “sealing air: principle” connection

Sealing air connectors are available for MHD motors. They are attached to the motor by simply replacing the motor flange socket cover. The overpressure inside the motor prevents penetrating oils, aggressive coolants, and the like from entering.

Note: When mounting the motor flange socket covers with sealing air connector, ensure that the O-rings are properly seated. The degree of protection required is ensured only with correct assembly.

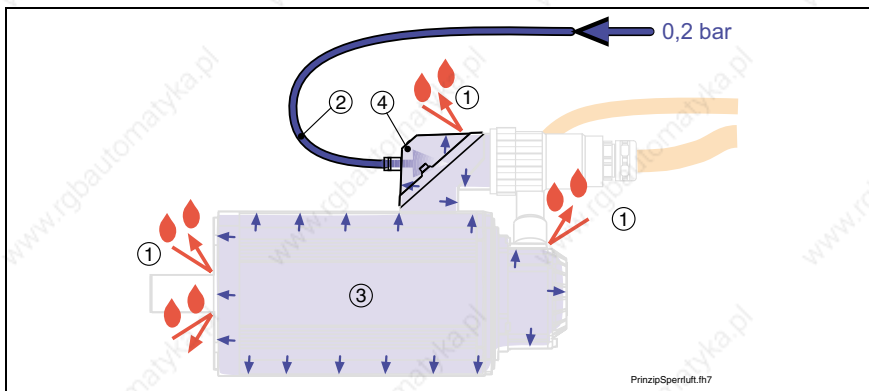

- (1): Splashwater, coolant
- (2): Compressed-air line (plastic pipe, type PA 4 x 0.75, or equivalent)
- (3): Overpressure inside the motor
- (4): Sealing air connector accessories

Fig. 13-6: Diagram illustrating the sealing air principle

Compressed-air data: Pressure 0.1...0.2 bar, max. 0.3 bar
Air free from dust and oil
relative air humidity 20...30%

Tightening torques To ensure the IP 67 degree of protection, the following tightening torques of the cover screws must be kept during mounting:

Set of accessories	Tightening torque in Nm
SUP-M01-MKD (terminal box)	2,5
SUP-M03-MHD (INS0613)	1,0
SUP-M01-MHD (INS0480)	3,0
SUP-M02-MHD (INS0380)	3,0

Fig. 13-7: Tightening torques

Supplier's recommended plastic pipe

Rexroth Mecman GmbH

Bartweg 13
D- 30453 Hannover
Postfach 91 07 62
D- 30427 Hannover
Phone: +49 (0) 5 11 21 36 - 0
Fax: +49 (0) 5 11 21 36 - 269

www.boschrexroth.de
www.rexroth-mecman.de

Plastic pipe, type PA 4 x 0.75

Dimension [mm]	Length [m]	Color	Order no.
4 x 0.75	25	blue	281 520 402 0
	50	blue	281 520 405 0

Fig. 13-8: Plastic pipe

Ordering name of accessory sets

The deliverable accessory sets are listed below.

accessory set (type)	Description	Motor
connection box	SUP-M01-MHD	MKD025 MKD041 MKD071 MKD090
INS0480 (power connector)	SUP-M01-MHD	MKD112 ¹⁾
INS0380 (power connector)	SUP-M02-MHD	MHD112C-058
INS0613 (feedback connector)	SUP-M03-MHD	MKD025
¹⁾ all MKD112 except MKD112C-058		

Fig. 13-9: Sealing air connector accessories

It must be ensured that, in each and every installation position, the motors are not subjected to ambient conditions outside of the particularly applicable degree of protection according to IEC 34-7.



Products and ranges with a low degree of protection are not suited for cleaning procedures with high pressure, vapor or water jet.

Selecting the Degree of Protection

The degree of protection must be selected depending on the installation position and the field of application.

The table below supports you in selecting the degree of protection required.

Exposure	Medium	Recommended
Dry	Air	Standard IP 65
Moist	Water General coolants Oil contents (approx. 5%)	Standard IP 65
	Penetrating oils, bio-oils Coolants	Standard IP 65 + sealing air
Splash	Water General coolants Oil contents (approx. 5%)	Standard IP 65 + sealing air
	Penetrating oils, bio-oils Coolants	

Fig. 13-10: Selecting the degree of protection

13.3 Design and Installation Positions

MKD motors are available in design B05. Please refer to the table below for the types of installation permissible according to EN 60034-7:1993.

Motor design	Permissible types of installation		
	Description	Sketch	Setup
B05	IM B5		Flange attached on the drive side of the flange
	IM V1		Flange attached on the drive side of the flange; drive side pointing down
	IM V3		Flange attached on the drive side of the flange; drive side pointing up

Fig. 13-11: Mounting position



DANGER

Penetration of fluids! If motors are attached according to IM V3, fluid present at the output shaft over a prolonged time may enter into and cause damage to the motors.

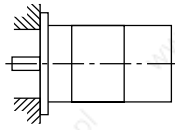
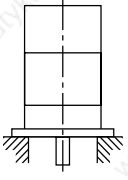
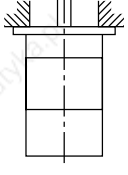
⇒ For that reason, ensure that fluid cannot be present at the output shaft.

Prime Coat and Housing Varnish

State upon delivery: Prime coat black in a/w RAL 9005

Resistance: Against weather, coloring, chalking, diluted acids and diluted lyes

It is not permitted to provide the housing with additional varnish (coat thickness no more than 40 µm).

Special designed model

For special use, e.g. food industry individual MKD motor types without painted housings can be delivered.

Note: The torque datas are reducing by ca. 15 – 20 % when the motor is not painted (see technical data).

13.4 Blower

In case of extreme loads, e.g. during continuous start-stop operation with high repeat frequencies, radial or axial blowers can be attached to the motors of the

- MKD071
- MKD090
- MKD112

motor type series. Please refer to the chapters entitled “Technical Data” for the various blower units.

When being ordered, blower units are specified as ordering subitem. It is possible to procure blower units separately or already attached to the motors. This information must be provided upon ordering. Please refer to the chapters entitled “Technical Data” for more detailed information on ordering data.

Note: Motors with attached blower units are **not suitable** for applications subjected to shock loads, such as are occurring in case of

- punches,
- presses, or
- loading portals.

In such cases, motors without surface-cooling and a higher torque must be used.

Notes on ordering:

Motor with attached blower unit

In order to procure a motor with attached surface-cooling, the type name of the blower unit must be specified as an ordering subitem of the MKD-motor with the blower arrangement desired.

Ordering item	Ordering name
1	1 ea Digital AC motor MKD071B-035-NG0-BN
1.1	1 ea Blower unit LEMD-RB071B2XX attached to item 1, blower arranged to the left

Fig. 13-12: Ordering data for an MKD motor with attached blower unit

Motor with separate blower unit

If it is specified as an independent ordering item, the blower unit is delivered separately from the motor (i.e. not attached to the latter).

Ordering item	Ordering name
1	1 ea Digital AC motor MKD071B-035-NG0-BN
2	1 ea Blower unit LEMD-RB071B2XX

Fig. 13-13: Ordering data for an MKD motor with separate blower unit

13.5 Holding Brakes

Optional. Required for holding the servo axis when the machine is in the de-energized state.



Hazardous movements! Persons endangered by falling or descending axes!!

- ⇒ The serially delivered motor holding brake does not suffice to ensure overall personal protection!
- ⇒ Ensure personal protection by superordinate failsafe measures:
 - ⇒ Block off the hazardous range by means of a safety fence or a safety screen.
 - ⇒ Additionally secure vertical axes to prevent them from falling or descending after having switched off the motor, for instance as follows:
 - lock the vertical axis mechanically,
 - provide an external braking / collecting / clamping device, or
 - ensure proper weight compensation of the axis.

The holding brake is operated according to the “electrically releasing” principle. In the de-energized state, a magnetic force acts upon the brake armature disk. This causes the brake to close and to hold the axis.

By applying 24 VDC, the permanent magnetic field is compensated by the electrically generated magnetic field: the brake opens.

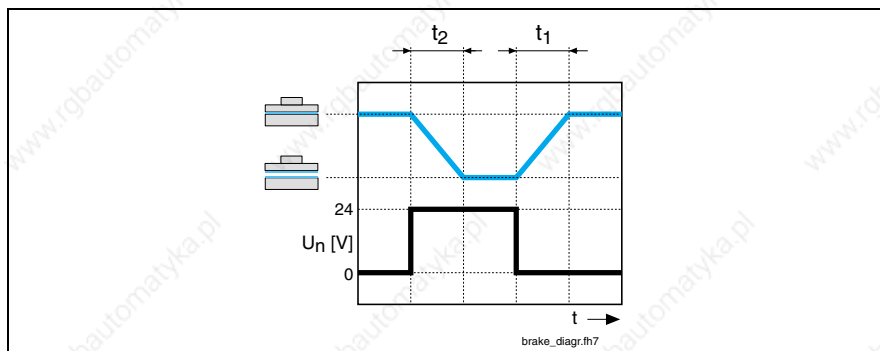

- t_1 : Connection time
- t_2 : Disconnection time

Fig. 13-14: Holding brake diagram

The holding brake is activated by the drive controller. This ensures the proper on and off order in all of the operating states.

Note: A premature wear and tear of the holding brake is possible!
The holding brake wears after approx. 20.000 motor revolutions in closed state. For that reason, do not use the holding brake as a system brake to stop a moving axis! This is permitted for EMERGENCY STOP situations only.

Please observe the instructions on putting the holding brakes into operation described in the chapter entitled "Startup, Operation, and Maintenance".

13.6 Output Shaft and Motor Bearing

Plain shaft

The standard design recommended for MKD motors provides a friction-locked shaft-hub connection without play and excellent running smoothness. Use clamping sets, clamping sleeves or clamping elements to couple the machine elements to be driven.

Output shaft with key

The optional key according to DIN 6885, Sheet 1, version 08-1968, permits keyed transmission of torques with constant direction, with low requirements for the shaft-hub connection.

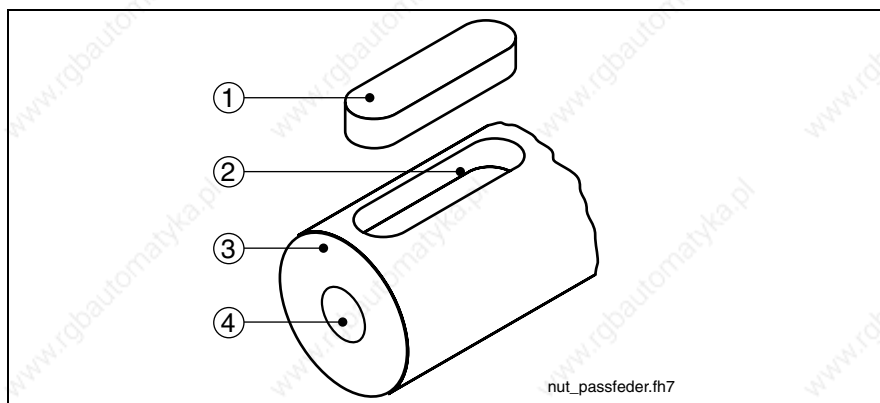

- (1): Key
- (2): Keyway
- (3): Motor shaft
- (4): Centering hole

Fig. 13-15: MKD output shaft with Key

The machine elements to be driven must additionally be secured in axial direction via the centering hole on the end face.



CAUTION

Shaft damage! In case of intense reversing operation, the seat of the key may deflect. Increasing deformations in this area can then lead to a break of the shaft!

⇒ Preferably, plain output shafts should be used.

Balancing with the complete key

MKD motors are balanced with the **complete** key. Hence, the machine element to be driven must be balanced without key.



Modifications to the keys may only be made by the user himself and on his own responsibility. Rexroth Indramat do not give any warranty for modified keys or motor shafts.

Output Shaft with Shaft Sealing Ring

MKD motors are designed with radial shaft sealing rings according to DIN 3760 – design A.

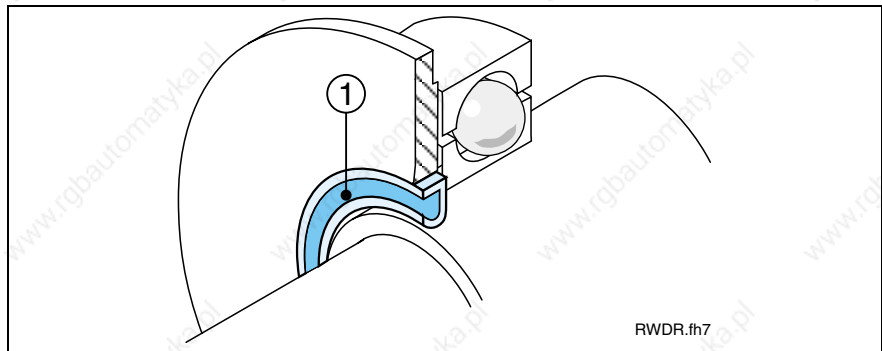

(1) Radial shaft sealing ring

Fig. 13-16: MKD radial shaft sealing ring

Wear and tear

Radial shaft sealing rings are rubbing seals. Hence, they are subject to wear and tear and generate frictional heat.

Wear and tear of the rubbing seal can be reduced only if lubrication is adequate and the sealing point is clean. Here, the lubricant also acts as coolant, supporting the discharge of the frictional heat from the sealing point.

⇒ Prevent the sealing point from becoming dry and dirty. Always ensure adequate cleanliness and lubrication.

Resistance

The materials used for the radial shaft sealing rings are highly resistant to oils and chemicals. The performance test for the particular operating conditions lies, however, with the machine manufacturer's responsibility.

At the moment of printing of the present document, the following material assignment is applicable:

Motor	Sealing material	Short name
MKD	Fluorocaoutchouc	FPM (Viton)

Fig. 13-17: MKD shaft sealing ring



The complex interactions between sealing ring, shaft and fluid to be sealed as well as the particular operating conditions (frictional heat, soiling, etc.) do not allow calculation of the lifetime of the shaft sealing ring. Under unfavourable terms can be an increase of probability of failure occurred.

Vertical installation positions IM V3

The degree of protection on the flange side of motors with shaft sealing ring is IP 65. Hence, tightness is ensured only in case of splashing fluids. Fluid levels present on side A require a higher degree of protection. If the motor is installed in vertical position (shaft pointing up), the instructions in the section "Design and Installation Positions" in this chapter must, in addition, be observed.

Note on construction Rexroth recommend that any direct contact of the output shaft and the radial shaft sealing ring with the processing medium (coolant, material corrosion), caused by the type of machine or system construction, should be avoided.

Bearings and Shaft Load

During operation, both radial and axial forces act upon the motor shaft and the motor bearings. The construction of the machine and the attachment of driving elements on the shaft side must be adjusted to one another to ensure that the load limits specified are not exceeded.

Radial load, axial load

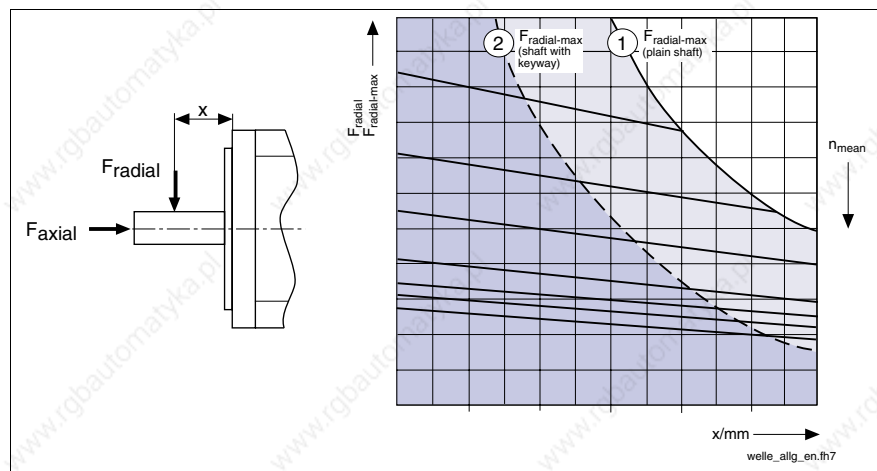

- (1): $F_{\text{radial_max}}$ (plain shaft)
 (2): $F_{\text{radial_max}}$ (shaft with keyway)

Fig. 13-18: Example of a shaft load diagram

Maximum permissible radial force $F_{\text{radial_max}}$

The maximum permissible radial force $F_{\text{radial_max}}$ depends on the following factors:

- Shaft break load
- Point of force application x (see Fig. 13-18)
- Shaft design (plain; with keyway)

Permissible radial force F_{radial}

The permissible radial force F_{radial} depends on the following factors:

- Arithmetic mean speed (n_{mean})
- Point of force application x (see Fig. 13-18)
- Bearing service life

Permissible axial force F_{axial}

The maximum permissible axial force F_{axial} is proportional to the radial force. Please refer to the section entitled "Shaft load" in the technical data for the proportionality factor.

Note: Owing to thermal effects, the flange-sided end of the output shaft may shift by 0.6 mm in relation to the motor housing. If skew bevel driving pinions or bevel gear pinions directly attached to the output shaft are used, this change in position will lead to

- a shift in the position of the axis, if the driving pinions are not defined axially on the machine side,
- to a thermally dependent component of the axial force, if the driving pinions are defined axially on the machine side. This causes the risk of exceeding the maximum permissible axial force or of the play within the gearing increasing to an impermissible degree.

In such cases, you should, therefore, preferably use drive elements with their own bearings, which are connected to the motor shaft via axially compensating couplings.

Bearing service life

If the MKD motors are operated within the limits specified for radial and axial loads, the nominal service life of the bearings is as follows:

Nominal bearing service life

$L_{10h} = 30.000$ operating hours
(calculated according to ISO 281, ed. 12/1990)

In other cases, the bearing service life is reduced as follows:

$$L_{10h} = \left(\frac{F_{radial}}{F_{radial_ist}} \right)^3 \cdot 30000$$

L_{10h} : (Bearing service life according to ISO 281, ed. 12/1990)
 F_{radial} : Determined permissible radial force in N (Newton)
 F_{radial_ist} : Actually acting radial force in N (Newton)

Fig. 13-19: Calculation of the bearing service life L_{10h} if the permissible radial force F_{radial} is exceeded

Note: Under no circumstances may the actually acting radial force F_{radial_ist} be higher than the maximum permissible radial force F_{radial_max} .

Attachment of drive elements

Redundant bearing

When attaching drive elements to the output shaft, be absolutely sure to avoid any redundant bearing. The tolerances inevitably present in such cases will lead to additional forces acting on the bearing of the motor shaft and, should the occasion arise, to a distinctly reduced service life of the bearing.

Note: If a redundant attachment cannot be avoided, it is absolutely necessary to consult with Rexroth.

13.7 Motor Encoder

To control the motor speed and/or to position the motor, the drive controller requires information on the current motor position.

To achieve this, the integrated encoder system (motor feedback) makes the appropriate signals available to the drive controller. The drive controllers are capable of transmitting the positional value thus determined to a superordinate CNC or SPS.

Encoder data memory ”

The encoder electronics is equipped with a data memory where the motor type name, the control loop parameters and the motor parameters are filed.

These data are read by the digital intelligent drive controllers by Rexroth. This ensures

- quick and easy startup,
- adjustment between the motor and the drive controller without the risk of damage to the motor.

Following encoder variants are available for MKD motors:

Option 1)	Encoder type	Measurement method	System precision	Position input type	Position resolution at the motor
G	Digital resolverfeedback	induktive	±8 angular minutes	Relative	MKD025 MKD041
K	Digital servo feedback (HSF with integrated multiturn absolute encoder	induktive	±8 angular minutes	Absolute (more than 4096 revolutions)	$3 \times 2^{13} = 24\,576$ MKD071 MKD090 MKD112 $4 \times 2^{13} = 32\,768$ Information / environment

Fig. 13-20: MKD motor encoder

Digital resolverfeedback

Provided for relative indirect position detection. Replaces separate incremental encoders at the motor.

Note: Characteristics of the resolverfeedback After a voltage failure or after the first POWER ON, the axis must first always be moved to its home position, before the processing can begin.

⇒ Consider when placing the home position circuit breaker and during the reference, that the resolver during a mechanical motor rotation generates several index signals.

- at MKD025, -041: 3 index signals per rotation
- at MKD071, -090, -112: 4 index signals per rotation

⇒ Avoid too high gear ratio or too slight feed-constant.

Digital servo feedback (RSF with integrated multiturn absolute encoder

Provided for absolute indirect position detection within 4096 motor revolutions. Replaces separate absolute value encoders at the motor.

Note: The absolute axis position at this encoder variety is still exist because of the battery back-up also after power shut down. The nominally durability of the batterie is about 10 years.

13.8 Acceptances, Approvals

CE mark

Declaration of conformity

Declarations of conformity certifying the structure of and the compliance with the applicable EN standards and EC guidelines are available for all MKD motors. If necessary, these declarations of conformity can be demanded from the pertinent sales office.

The CE mark is applied to the motor type label of the MKD motors.

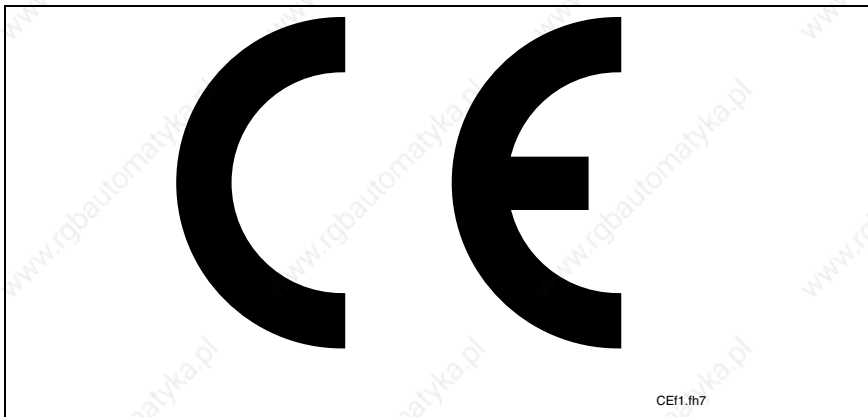

Fig. 13-21: CE mark

UR, cUR Listing

The MKD motors listed below have been presented to the UL authorities "Underwriters Laboratories Inc.®".

- MKD041A, -B
- MKD071A, -B
- MKD090B
- MKD112A, -B, -C, -D

The motors have been approved by the UL authorities under the file number **E163211** and have been marked on their motor type label with the following sign:



Fig. 13-22: cUR mark

Note: When printing this document the certification for the MKD025 motors is still not completed.

14 Handling

14.1 Identifying the Goods

Delivery note A single copy of the delivery note is enclosed to each delivery. The delivery note lists all components with their ordering name and their designation. If the contents are distributed among several parcels (transport containers), then this is noted on the delivery note or it can be seen from the freight bill.

Bar code label Each motor package is provided with a bar code label providing the following data:

- Type name of the motor
- Customer
- Delivery note number
- Consignment
- Forwarding agent ordered

The bar code label is provided for identification of the contents during processing of the order.

14.2 Type Labels

Motor The motor is delivered including a type label. The type label is attached to the motor housing. In addition, a second type label is adhered onto the original type label on the motor housing, using double-sided adhesive tape. The latter type label can be put well visible on the machine, if the original type label on the motor be concealed by parts of the machine.

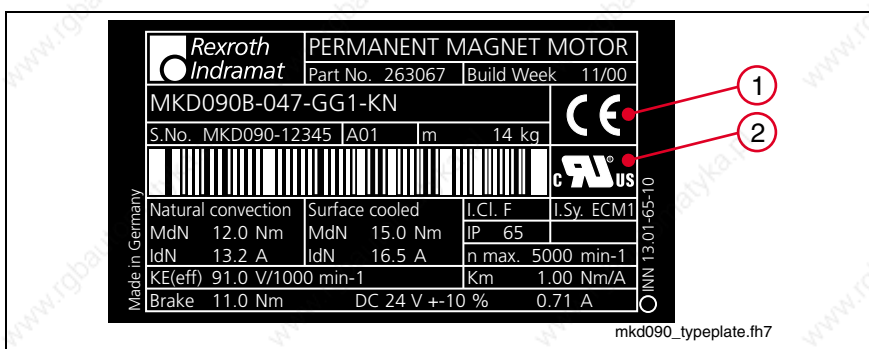

(1): CE mark

(2): cUR mark; not applicable in case of non-approved motor types

Fig. 14-1: MKD type label (example)

The type label is provided for

- identification of the motor,
- procurement of spare parts in case of a failure,
- service information.

Note: The type name of the motor is also filed in the encoder data memory.

Cable sets

Cable sets by Rexroth are identified by a cable type label (label at the end of the cable). The cable type label specifies the ordering name as well as the length of the cable.

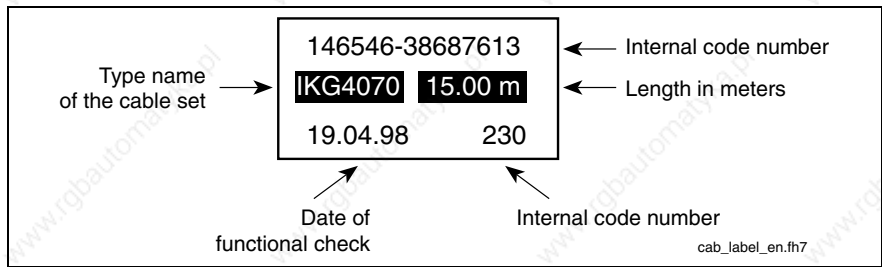

Fig. 14-2: Cable type label

**Non-prepared cables
Raw cable type**

The name of the raw cable type is printed on the cable sheath. When ordering raw cables, the desired length in meters must be specified in addition to the raw cable type.

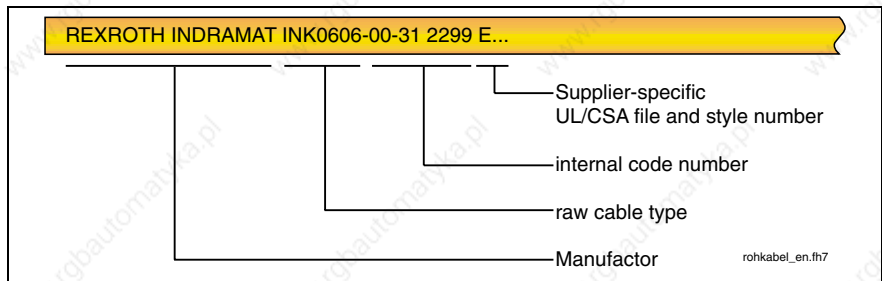

Fig. 14-3: Raw cable name

14.3 Instructions on the Packing

Instructions on storage, transport and handling of the parcels are printed on the packing. It is absolutely necessary that these instructions be observed.

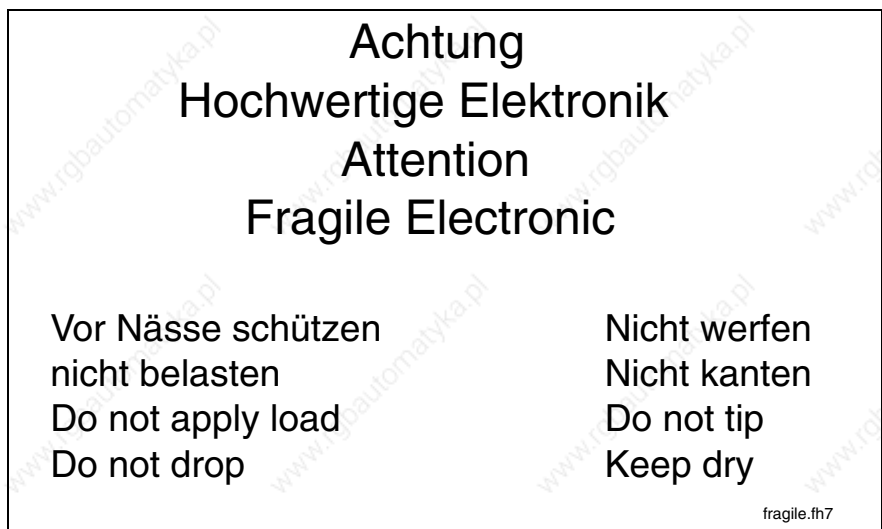

Fig. 14-4: Instructions on storage, transport and handling on the packing

14.4 Storage



WARNING

Damage to motor and loss of warranty possible!

Any improper storage may cause damage to the motor.
In addition, any warranty claim will expire.

⇒ For that reason, please observe the following instructions.

The following conditions must be kept during storage:

- Permissible range of temperature: -20° C up to +80 °C.
- Store motors at dry places which are free from dust and vibrations.
- Store motors horizontally.
- Do not remove the plastic protective sleeve on the drive shaft. It protects the shaft from moisture and mechanical damage.

14.5 Transport and Handling



WARNING

Damage to motor and loss of warranty possible!

Improper transport and handling may cause damage to the motor. In addition, any warranty claim will expire.

⇒ For that reason, please observe the following instructions.

The following conditions must be kept during transport and handling:

- Use the appropriate means for transport. Take the weight of the components into consideration (weights are specified in the chapters pertaining to the various motors, in the sections on technical data and/or on the type label of the motor).
- Provide for shock absorption, if strong vibrations may occur during transport. Please also observe the limits specified in Chapter 12.5, "Maximum Vibration and Shock Loads".
- Transport only in horizontal position.
- Use cranes with lifting sling belts to lift the motors.
- Avoid damage to the motor flange and the drive shaft.
- Avoid impacts on the drive shaft.
- Remove the plastic protective sleeve from the drive shaft only shortly before mounting the motors.

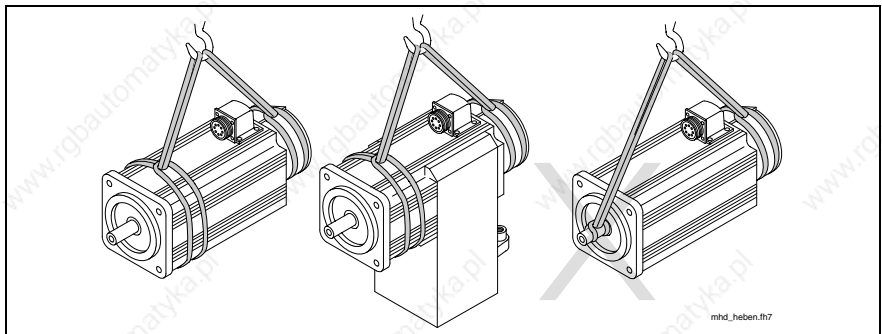

Fig. 14-5: Lifting and transporting the motors by means of lifting sling belts

15 Assembly

15.1 Skilled Technical Personnel

Any work on the system and on the drives or in their vicinity may only be carried out by appropriately trained technical personnel. The owner of the system must ensure that all persons carrying out

- installation work,
- maintenance measures, or
- operation activities

on the system are adequately familiar with the contents of this documentation as well as with all warnings and precautionary measures contained therein. Qualified technical personnel must have been trained and instructed and are authorized to activate and deactivate, ground and mark electric circuits and equipment according to the safety rules and regulations. Qualified technical personnel must possess the appropriate safety equipment and have been trained in first aid.

15.2 Mounting the Motor

General for mounting

Observe all warnings and safety advices mentioned in Chapter 3. This minimizes the risk of accidents and damage to the system or the motor.

Do all handling advices carefully. This ensures correct mounting and dismounting of the components.

MKD motors comply with design B5 in accordance with DIN 42950, Part 1, ed. 08.77. Please refer to the dimensional sheets in Chapters 6 to 13 for all relevant dimensional details.

Before mounting:

1. Procure tools, auxiliary materials, measuring and test equipment.
2. Control all components if they are clean.
3. Proof all components if they are obviously damaged. Defective components may not be mounted.
4. Ensure that mounting can be done in a dry and clean environment.
5. Ensure that the holder for the motor flange is without burrs.

If the optional holding brake is used

Mounting the MKD motors:

Mount the motor. All of the measures and tolerances specified in the dimensional sheets must be kept.

To fix the flange, we recommend to use the screws and tightening torques listed in the table below.

Motor frame size	Recommended screw size	Tightening torque [Nm]	Minimum strength
MKD025	4x M4	3,1	8.8
MKD041	4 x M6	10,4	8.8
MKD071	4 x M8	25	8.8
MKD090	4 x M10	51	8.8
MKD112	4 x M12	87	8.8

Fig. 15-1: Locking screws

Note: The screwed connections must be able to take up both the force due to the force of the motor and the forces acting during operation.

15.3 Connecting the Motor

After having mounted the motor mechanically as specified, proceed to connecting the motor.



DANGER

Danger to life by electric voltage! Handling within the range of live parts is extremely dangerous. Therefore:

- ⇒ Any work required on the electric system may only be carried out by skilled electricians. It is absolutely necessary to use electric tools.
- ⇒ Before starting work, the system must be de-energized and the power switch be secured against unintentional or unauthorized re-energization.
- ⇒ Before starting work, the appropriate measuring equipment must be used to check whether parts of the system are still applied to residual voltage (e.g. caused by capacitors, etc.). If yes, wait until these parts have discharged.



WARNING

Injuries to persons or property are possible! Interrupting or connecting live lines may cause unpredictable dangerous situations or lead to physical damage. Therefore:

- ⇒ Connect and disconnect plug connectors only when they are dry and de-energized.
- ⇒ During operation of the system, all plug connectors must be securely tightened.



WARNING

Risk of short-circuit caused by liquid coolant or lubricant! Short-circuits of live lines may cause unpredictable dangerous situations or lead to physical damage. Therefore:

- ⇒ Provide open mating sides of power plug connectors with safety caps when installing or replacing drive components, if you cannot exclude that they might be moistened with liquid coolant or lubricant.

The connection diagrams by Rexroth are exclusively intended for the preparation of system circuit diagrams!

- ⇒ Connect the motor as specified in the machine manufacturer's system circuit diagram! Refer to the connection diagram in Chapter for support.

Motor with connection box



WARNING

Damages on connection box or at the cable are possible! Too high accelerating torques can damage the bolt-on fixing or can squeeze the cable. If bolt-on fixings are damaged, the protection IP65 cannot be ensured any longer.

⇒ In fact of this use no automatic screwdriver (e.g. electrical, pneumatic or hydraulic screwdriver).

Use cables for this motors which are equivalent with Rexroth cables. Mount the cables as follows:

1. Dismount the connector-box cover (1), by untwining the screws(7).
2. Dismount the components (2 -5), by untwining the screws (6).
3. Remove protection paper (A).
4. Pull off the inserted connectors X1 and X2 from the motor connection plate.

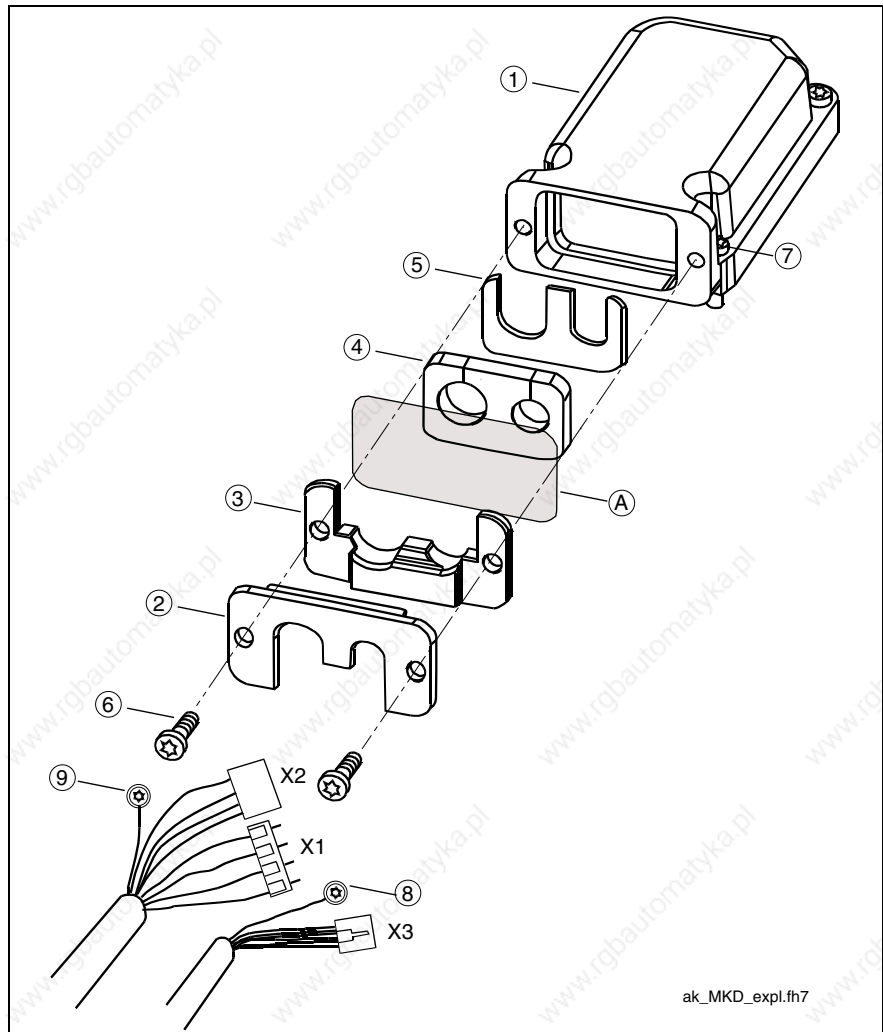

Fig. 15-2: Explosion-delineation of the connector box.

5. Bring on the parts (2 – 5) round the cable.
6. Lead the cable-ends through the opening of the connection box (see Fig. 15-2) and turn on the screws loose(6) of the cable bushing.

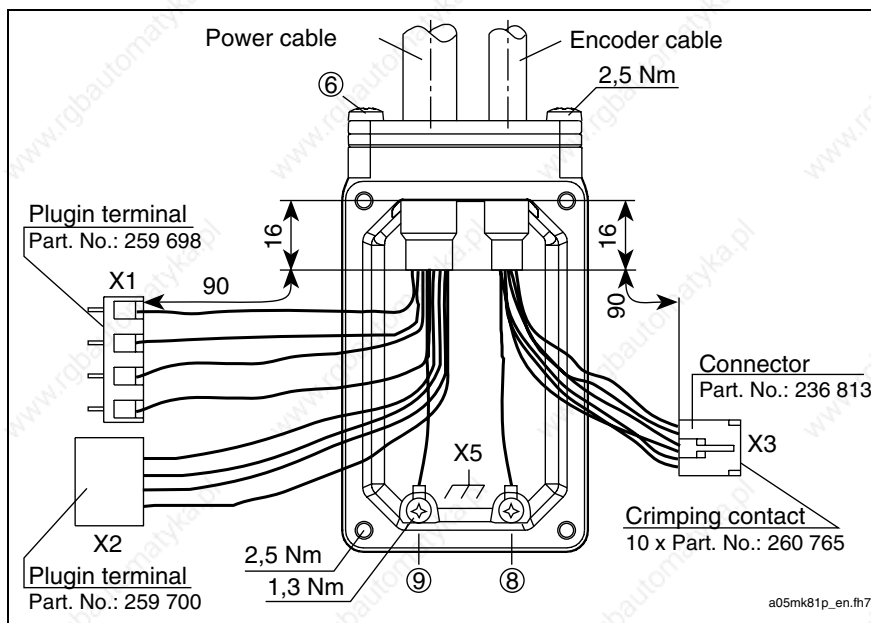

Fig. 15-3: Entrance of power and conductor cables

7. Pull back the cable until the shrinking sleeve penetrates the inside of the connection box by about 16mm (see Fig. 15-3).
8. Tighten screws (6) with 2,5 Nm.
9. Tighten up grounding ring terminals (8) and (9) with 1.3 Nm to connector box lid (1).
10. Insert connectors X1, X2 and the encoder connector X3 into appropriate position on the motor panel.
11. Tighten screws in the terminal X1 with 0.5 Nm.
12. Place the connector box into output direction.
13. Make sure that no cable cores are squeezed or damaged and tighten the connector box into place with 2.5 Nm.

Adjust the output direction

The connector box lid can be turned 180° when it is mounted. This means the output direction can be set to:

- side A or
- side B.

Note: The cable output direction is side B at the time of delivery.

The cable output direction can be selected when mounting power and encoder cable.

Motors with plug-in connectors

Power connector

Power connectors for MKD025

When fitting the INS0681 power connector with thread, proceed as follows:

1. Put the power connector onto the thread of the connection housing in the correct position.
2. Tighten the union nut of the power connector manually. By leading the cable in further, the power connector can be steadily put to its final position.
3. Tighten the union nut as securely as you can manually.

Power connector for MKD112

When fitting the INS0381 or INS0481 power connector with bayonet lock, proceed as follows:

1. Put the power connector onto the bayonet lock of the connection housing in the correct position.
2. Turn the union nut of the power connector in manually until it snaps into the final position (i.e. when the red dots comply with the red triangles).

Encoder connector

Encoder connector

When fitting the encoder connectors, proceed as follows:

1. Put the encoder connector onto the thread of the connection housing in the correct position.
2. Tighten the union nut of the power connector manually. By leading the cable in further, the encoder connector can be steadily put to its final position.
3. Tighten the union nut as securely as you can manually.

**Changing the output direction
on MKD025****Adjust the output direction of power connector**

The output direction on MKD025 motors can be chosen when mounting the power connector. The flange sockets are designed such that they can be turned (angle of rotation of 270 degrees).

Adjustment of the desired connector output direction is described below.

Note: Do not use any tools (e.g. tongs or pliers or screwdrivers) to turn the motor flange socket. Mechanical damage to the flange socket when using tools cannot be excluded.

The motor flange socket can be turned easily if an appropriate plug has been connected. Owing to the leverage of the connected plug, the flange socket can be turned manually to the desired output direction.

Proceed as follows:

1. Connect the motor power cable to the flange socket.
2. Put the flange socket to the desired output direction by turning the connected plug.

The desired output direction is set.

Note: Whenever the flange socket is turned, the holding torque in the set position is reduced. To ensure the required holding torque of the flange socket, the output direction should be changed no more than 5 times!

It is not necessary to “rebuild” the flange socket (i.e. dismantling and mounting the flange socket, relocated by 90 degrees). The following problems and risks can arise should the flange socket be “rebuilt”:

- The O-ring seal between the flange socket and the motor housing is not ensured any longer.
- The tightening torques prescribed are, perhaps, not kept.
- The TFL coating (screw locking element) of the locking screws will wear by unscrewing, thus becoming ineffective.

Note: No warranty!

- If the cable output direction is changed by “**rebuilding**” the flange socket, the warranty for the overall drive system given by Rexroth will expire. The cable output direction may only be changed by turning the flange socket.
-

Changing the output direction on MKD112

The flange socket on MKD112 motors can be turned by steps in 90° (output direction A,B, L, R see type code).

To achieve this, proceed as follows:

1. Loosen the two locking screws (4) and remove the cover of the flange socket (2).
2. Loosen the four locking screws (3).
3. Now turn the flange socket housing (1) into appropriate position (by steps in 90°).
4. Ensure that cable strands are prevented from being damaged or tensioned unnecessarily.
5. Retighten the four locking screws (3) (tightening torque: 3.1 Nm \pm 10%).
6. Ensure that, when retightening the screws, cable strands and the seal are prevented from being damaged.
7. Reattach the cover of the flange socket (2) to the connector housing (1) and retighten the two locking screws (4) (tightening torque: 3.1 Nm \pm 10%).

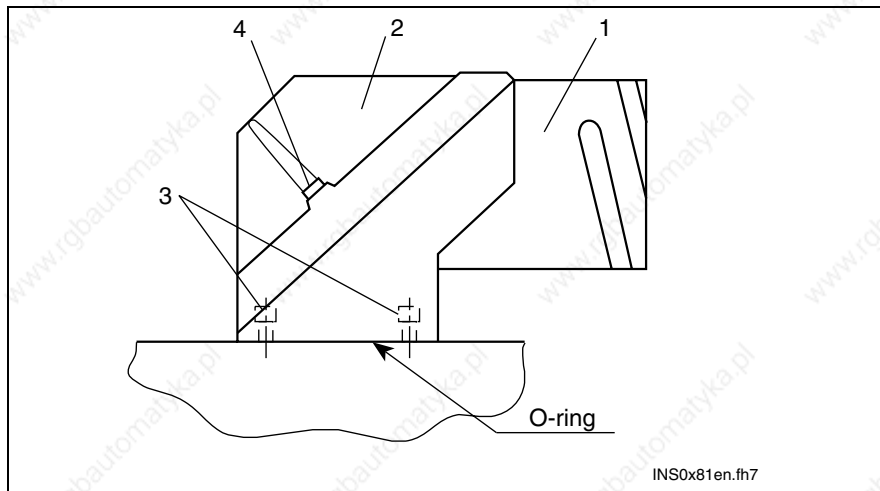

- (1): Flange socket housing
 (2): Flange socket lid
 (3): Flange socket housing screws
 (4): Flange socket lid screws

Fig. 15-4: Flange socket

Note: The connector output direction can be selected upon ordering by specifying it accordingly in the type code (output direction A, B, L, R).

**Changing the output direction
on MKD025****Adjust the output direction of encoder connector**

The output direction on MKD025 motors can be chosen. The flange sockets are designed such that they can be turned (angle of rotation of 270 degrees).

Adjustment of the desired connector output direction is described below.

Note: Do not use any tools (e.g. tongs or pliers or screwdrivers) to turn the motor flange socket. Mechanical damage to the flange socket cannot be excluded.

The motor flange socket can be turned easily if an appropriate plug has been connected. Owing to the leverage of the connected plug, the flange socket can be turned manually to the desired output direction.

Proceed as follows:

1. Connect the encoder cable to the flange socket.
2. Put the flange socket to the desired output direction by turning the connected cable.

The desired output direction is set.

Note: Whenever the flange socket is turned, the holding torque in the set position is reduced. To ensure the required holding torque of the flange socket, the output direction should be changed no more than 5 times!

It is not necessary to “rebuild” the flange socket (i.e. dismantling and mounting the flange socket, relocated by 90 degrees). The following problems and risks can arise should the flange socket be “rebuilt”:

- The O-ring seal between the flange socket and the motor housing is not ensured any longer.
- The tightening torques prescribed are, perhaps, not kept.
- The TFL coating (screw locking element) of the locking screws will wear by unscrewing, thus becoming ineffective.

Note: No warranty!

- If the cable output direction is changed by “**rebuilding**” the flange socket, the warranty for the overall drive system given by Rexroth will expire. The cable output direction may only be changed by turning the flange socket.
-

Changing the output direction on MKD112

The output direction on MKD112 motors can be chosen. The output direction can be turned by 90°. To achieve this, proceed as follows:

1. Loosen the four locking screws on the top of the connector.
2. Turn the plug part with union nut in relation to the connector housing into the desired position (in increments of 90 degrees).
3. Retighten the locking screws (tightening torque: 0.8 Nm \pm 10%).
4. Ensure that, when retightening the screws, cable strands and the seal are prevented from being damaged.

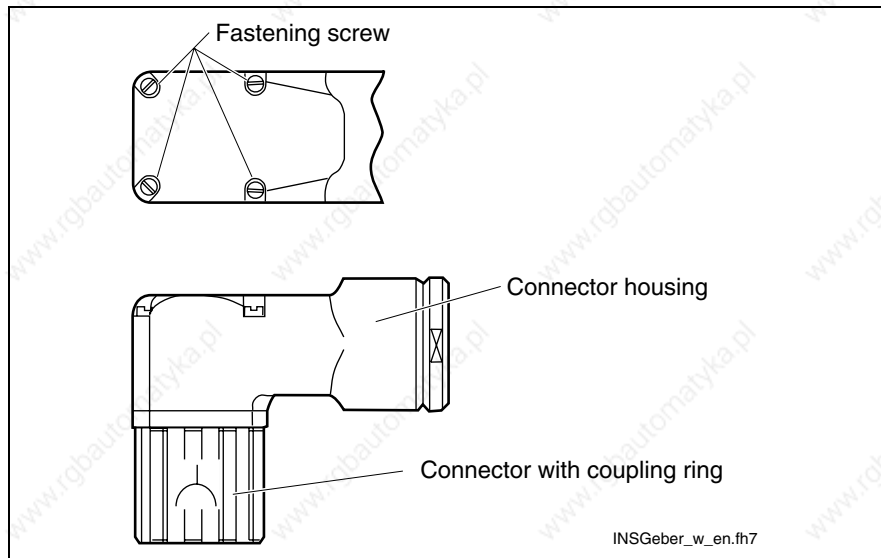

Fig. 15-5: Angular connector (encoder unit)

Note: In case of applications with high vibration and shock loads, the angular connector must be secured against loosening by means of screw locking adhesive.

16 Startup, Operation, and Maintenance

16.1 Startup

The MKD motors may be put into operation only if they have been carefully and properly mounted and if the electric connection has been properly established.

Before startup

Before putting the MKD motors into operation, the following must be checked and/or ensured:

- It must be possible to turn the rotor manually with the holding brake opened; there may be no running noise (e.g. rubbing). If necessary, the holding brake must be opened by applying a DC voltage of 24 V $\pm 10\%$.
- The motor must be mounted and aligned correctly. The motor flange must be coupled to the machine structure or the gear absolutely even.
- It must be ensured that all electric connections (motor and drive controller) have been established as specified and that the cable screw unions have been tightened.
- It must be ensured that the protective conductor and/or the protective grounding have been executed properly.
- If the optional holding brake is used, its operational reliability must be ensured.
- Shock protection measures against live and moving parts must be provided for.

Startup

MKD motors may be put into operation only with drive controllers by Rexroth. After the connection has been properly established and the above requirements are complied with, the MKD motor can be put into operation via the drive controller.

Note: Startup of the drives is described in the product documentation of the particular drive controllers. Request the corresponding product documentation from your local sales office.

16.2 Operation

Ensure that the ambient conditions described in Chapter 13 "Application Instructions", are kept during operation.

16.3 Maintenance

Cleaning

Excessive dirt, dust or shavings may affect the function of the motors adversely, may in extreme cases even cause a failure of the motors. For that reason, you should clean

- Cooling ribs**
- the cooling ribs of the motors at regular intervals, in order to obtain a sufficiently large heat radiation surface. If the cooling ribs are dirty in part, sufficient heat dissipation via the environmental air is not possible any longer.

An insufficient heat radiation may have undesired consequences. The bearing service life is reduced by operation at impermissibly high temperatures (the bearing grease is decomposing). Switchoff caused by overtemperature despite operation on the basis of selected data, because the appropriate cooling is missing.

Bearings

The nominal service life of the bearings is $L_{10h} = 30.000$ h according to DIN ISO 281, ed. 1990, if the permissible radial and axial forces are not exceeded (see Chapter 16.7). Even if the bearings are loaded with higher forces to a minor degree only, their service life is affected negatively.

The motor bearings should be replaced if

- the nominal bearing service life has been reached,
- running noise can be heard.

Note: We recommend that bearings are replaced by the Rexroth Indramat Service.

Connection Cable

Check connection lines for damage at regular intervals and replace them, if necessary.

Check any optionally present energy management chains (drag chains) for defects.



DANGER

Electrocution by live parts of more than 50 V!

⇒ Do not repair any connection lines provisionally. If the slightest defects are detected in the cable sheath, the system must be put out of operation immediately. Then the cable must be replaced.

Check the protective conductor connection for proper state and tight seat at regular intervals and replace it, if necessary.

Holding brake

In order to ensure proper functioning of the holding brake, it must be checked before the motors are installed.

Before initial startup Measure the holding torque of the brake; grind in the holding brake, if necessary.

Proceed as follows:

1. De-energize the motor and secure it against re-energization.
2. Measure the transmittable holding torque of the holding brake using a torque spanner. The holding torque of the brakes is specified in the data sheets.
3. If the holding torque specified in the data sheets is reached, the holding brake is ready for operation.
If the holding torque specified in the data sheets **fails to be reached**, the holding brake must be ground in as described in step 4.
4. **Grinding in:** With the holding brake closed, manually turn the output shaft by approx. five revolutions and measure the transmittable holding torque of the brake using a torque spanner.
5. If the holding torque specified in the data sheets is reached, the holding brake is ready for operation.
If the holding torque specified in the data sheets **fails to be reached**, repeat steps 4 and 5 of the grinding-in process.

If the holding torque specified fails to be reached after the second grinding-in process, the holding brake is not operable. Notify the Rexroth Service.

During operation If holding brakes are required only sporadically (braking cycle >48 h) during operation, film rust may develop on the brake friction surface.

To prevent the holding torque specified from being fallen below, we recommend to proceed as described below:

Recommendation for seat grinding	
Interval	Once in 48 h
Grinding-in speed	100 min ⁻¹
Number of grinding-in revolutions	1
Ambient temperature	-20 °C to +50 °C

Fig. 16-1: Recommended procedure for grinding in motor holding brakes

Note: The option of automatically implementing the grinding-in routine in the program run is described in the documentation of the particular drive controllers.



During normal operation, it is not necessary to grind in the brake. It is sufficient if the brake is activated twice a day by removing the controller enable signal.

Changing the battery

Drive control systems of Rexroth observe voltage of battery safely and give just in time a warning "change battery".

Change battery when machine is under load

Changing the battery should be made, when machine is under load. This is necessary to avoid an overrun in the motor encoder (switch off control voltage can cause loss of absolute values).

Change battery

Following tools and spare parts are needed:

- Screw driver Torx according to Fig. 16-2
- Needle-nosed pliers
- Torque spanner with setting range 1.3-6.8 Nm.
- New, assembled battery for
MKD025, -041, -071. Ord. No. R911277133
MKD090, -112 Ord. No. R911281394

housing-screw	thread	Screw driver size	Starting torque
MKD025, -041	M3	Torx T 10	1.4 Nm
MKD071, -090, -112:	M4	Torx T 20	3.0 Nm

Fig. 16-2: Overview housing-screws



DANGER

Danger to life by electric voltage!

To change the battery you must work when machine is under load. Therefore:

- ⇒ Any work required on the electric system may only be carried out by skilled electricians.
- ⇒ Switch off power supply at the drive control systems and save against re-start!



DANGER

Hazardous movements!

Danger to life, mayhem or material damage!

- ⇒ Switch off power supply at the drive control systems and save against re-start!
- ⇒ Change battery on drive control systems only when control voltage is inserted. Is the control voltage switched off when the battery is removed, the absolute value is lost and when the machine will be switched on, a failing movement could be possible.

Remove the battery

1. Loosen housing screws (1) with a torx-screw driver (appropriate size see Fig. 16-2).
2. Dismount housing lid.
3. Take off the connector of the battery (2).
4. Loosen screws (3) of the battery's screw terminal and remove the battery.

- Assemble the battery**
1. Assembled battery for motor type (Ord. No. No.: R911277133 or: R911281394) and screw terminal (3) with screws (4) tighten (accelerating torque max. 1.0 Nm).

Note: Do not squeeze the battery cable!

2. Take on the connector of the battery (2).
3. Close housing lid.
4. Tighten screw (1) with torque spanner (accelerating torque see Fig. 16-2).

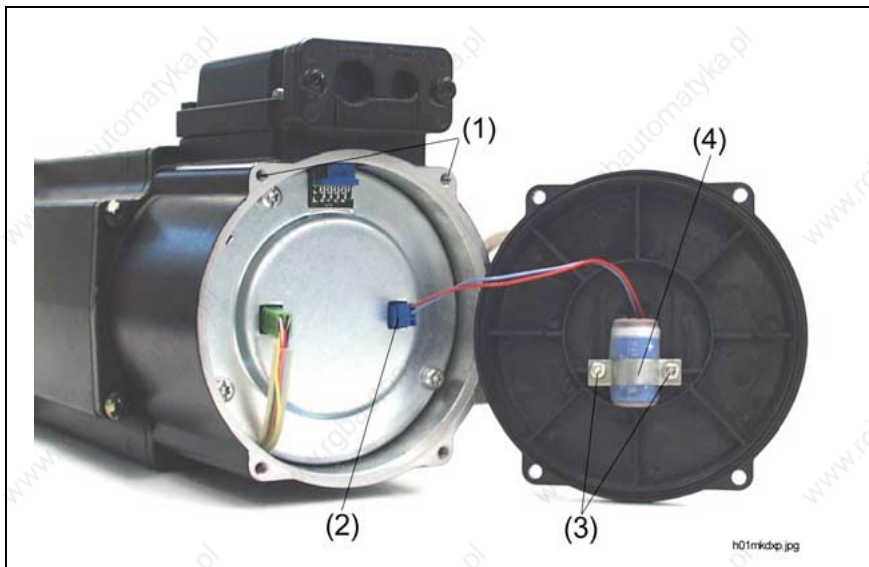

- (1): housing-screw
(2): Battery connector
(3): Screws for mounting the battery.
(4): Battery

Fig. 16-3: Change battery

- Restart the system**
5. Turn on power supply of drive control system.
 6. Do a testing of the axis.

17 Appendix

17.1 List of Standards

Standard	Edition	Title	Concordance
89/392/EEC replaced by 98/37/EG	1998-06-22	Directive 98/37/EC of the European Parliament and of the Council of 22 June 1998 on the approximation of the laws of the Member States relating to machinery	
89/336/EEC	1989-05-03	COUNCIL DIRECTIVE of 3 May 1989 on the approximation of the laws of the Member States relating to electromagnetic compatibility (89/336/EEC)	
DIN EN 50178; VDE 0160	1998-04	Electronic equipment for use in power installations; German version EN 50178:1997	EN 50178(1997-10)
DIN VDE 100-410; VDE 100 Part 410 IEC 60364-4-41	1997-01	Erection of power installations with nominal voltages up to 1000 V - Part 4: Protection for safety; Chapter 41: Protection against electric shock (IEC 60364-4-41:1992, modified); German version HD 384.4.41 S2:1996	HD 384.4.41 S2(1996-04); IEC 6036-4-41(1992-10)
DIN 332-2	1983-05	Center holes 60° with thread for shaft ends for rotating electrical machines	
DIN 6885-1	1968-08	Drive Type Fastenings without Taper Action; Parallel Keys, Keyways, Deep Pattern	
DIN EN 60034-1; VDE 0530 Part 1	2000-09	Rotating electrical machines - Part 1: Rating and performance (IEC 60034-1:1996, modified + A1:1997 + A2:1999); German version EN 60034-1:1998 + A1:1998 + A2:1999	EN 60034-1(1998-05); EN 60034-1/A1(1998-05); EN 60034-1/A2(1999-08); IEC 60034-1(1996-11); IEC 60034-1 AMD 1(1997-06); IEC 60034-1 AMD 2(1999-05)
DIN VDE 0298-4; VDE 0298 Part 4	1998-11	Application of cables and cords in power installations - Part 4: Recommended current-carrying capacity for sheathed and non-sheathed cables for fixed wirings in buildings and for flexible cables and cords	
DIN EN 60204-1; VDE 0113 Part 1	1998-11	Safety of machinery - Electrical equipment of machines - Part 1: General requirements (IEC 60204-1:1997 + Corrigendum 1998); German version EN 60204-1:1997 (In addition, DIN EN 60204-1 (1993.06) is applicable until 2001.07.01. DIN VDE 60204-1 (1993.06) is applicable until further notice as the reference standard for EN 60204-3-1 (1990.08), which has been published in Germany as DIN EN 60204-3-1 (1993.02).	EN 60204-1(1997-12); IEC 60204-1(1997-10)
DIN 42955	1981-12	Tolerances of shaft extension run-out and of mounting flanges for rotating electrical machinery, test	IEC 60072(1971)
DIN 748-3	1975-07	Cylindrical Shaft Ends for Electrical Machines	IEC 60072(1971)
DIN VDE 0530-14 replaced by DIN EN 60034-14; VDE 0530 Part 14	1997-09	Rotating electrical machines - Part 14: Mechanical vibration of certain machines with shaft heights 56 mm and higher; measurement, evaluation and limits of vibration (IEC 60034-14:1996); German version EN 60034-14:1996	EN 60034-14(1996-12); IEC 60034-14(1996-11)
IEC 721-3-3 replaced by DIN EN 60721-3-3	1995-09	Classification of environmental conditions - Part 3: Classification of groups of environmental parameters and their severities; section 3: Stationary use at weather-protected locations (IEC 60721-3-3:1994); German version EN 60721-3-3:1995 Modified by DIN EN 60721-3-3/A2 dated July 1997	EN 60721-3-3(1995-01); IEC 60721-3-3(1994-12)
IEC 721-1 replaced by DIN IEC 60721-1	1997-02	Classification of environmental conditions - Part 1: Environmental parameters and their severities (IEC 60721-1:1990 + A1:1992 + A2:1995); German version EN 60721-1:1995 + A2:1995	EN 60721-1(1995-04); EN 60721-1/A2(1995-07); IEC 60721-1(1990-12); IEC 60721-1 AMD 1(1992-12); IEC 60721-1 AMD 2(1995-04)
DIN EN 60529; VDE 0470 Part 1	2000-09	Degrees of protection provided by enclosures (IP code) (IEC 60529:1989 + A1:1999); German version EN 60529:1991 + A1:2000 (In addition, DIN VDE 0470-1 (1992-11) may still be used until 2003-01-01.)	EN 60529(1991-10); EN 60529/A1(2000-02); IEC 60529(1989-11); IEC 60529 AMD 1(1999-11)
DIN EN 60034-7; VDE 0530 Part 7	1996-06	Rotating electrical machines - Part 7: Classification of types of constructions and mounting arrangements (IM code) (IEC 60034-7:1992); German version EN 60034-7:1993	EN 60034-7(1993-01); IEC 60034-7(1992-12)
DIN 3760	1996-09	Rotary shaft lip type seals	
DIN ISO 281	1993-01	Rolling bearings; dynamic load ratings and rating life; identical with ISO 281:1990	

Fig. 17-1: List of standards

17.2 Selecting Power Cables

The tables and diagrams shown on the following pages are intended to support you in selecting the power cables required. The example below explains how to proceed.

Example A power cable set, **5.0 m in length**, is needed for a **MKD112A-024** motor, **Natural 60K** operating mode, and an **HDS02**. drive controller.

Proceed as follows:

1. Select the motor and the operating mode in the cable selection table.
2. "X" identifies the connection cross-section required.
3. Read the size of the power connector and the connection cross-section from the table header.
4. On the following pages, select the corresponding selection diagram by connector size and connection cross-section.
5. Select the required power cable set in the diagram. Complete the selected ordering type **IKGxxxx/xxx.x** by the desired length.

In the example above, the ordering type IKG4055/xxx.x is taken from the selection diagram. For ordering, complete the ordering type by the desired length.

Ordering type: IKG4055/005,0

17-5 Appendix
Synchronous Motors MKD

Selecting Power cables

Motor MKD	Operating mode	Connection cross-section				
		INS0680, 1,0mm ²	INS0642, 1,0mm ²	INS0480, 1,5mm ²	INS0480, 1,5mm ²	INS0480, 2,5mm ²
041B-143	Natural 60K		X			
041B-144	Natural 100K		X			
071A-035	Natural 60K		X			
071A-035	Natural 100K		X			
071A-061	Natural 60K		X			
090B-046	Natural 100K		X			
090B-046	Natural 60K		X			
090B-047	Natural 100K		X			
090B-047	Surface 60K/100K		X			
090B-058	Natural 60K		X			
090B-058	Natural 100K		X			
112A-024	Surface 60K/100K		X			
112A-024	Natural 60K		X			
112A-024	Natural 100K		X			
112A-058	Surface 60K/100K		X			
112A-058	Natural 60K		X			
112A-058	Natural 100K		X			
112A-058	Surface 60K/100K		X			

17-5 Appendix
Synchronous Motors MKD

INS0480 1,5mm²

Direct connection

Intermediate connection

- (1): Select motor type and operating mode.
- (2), (3) : Read the connector size and the cross-section off the column header.
- (4): Consult the corresponding diagram.
- (5): Select the desired cable.

Fig. 17-2: Instructions on how to select a cable

Motor MKD	Mode of operation	INS0680, 1,0mm ²	INS0542, 1,0 mm ²	INS0480, 1,5mm ²	INS0480, 2,5mm ²	INS0480, 4,0mm ²	INS0480, 6,0mm ²	INS0480, 10,0mm ²	INS0380, 6,0mm ²	INS0380, 10,0mm ²	INS0380, 16,0mm ²		
025A-144 Stecker	Natural 60K	X											
	Natural 100K	X											
025A-144 terminal box	Natural 60K		X										
	Natural 100K		X										
025B-058 Stecker	Natural 60K	X											
	Natural 100K	X											
025B-058 terminal box	Natural 60K		X										
	Natural 100K		X										
025B-144 Stecker	Natural 60K	X											
	Natural 100K	X											
025B-144 terminal box	Natural 60K		X										
	Natural 100K		X										
041B-143	Natural 60K		X										
	Natural 100K		X										
041B-144	Natural 60K		X										
	Natural 100K		X										
071B-024	Natural 60K		X										
	Natural 100K		X										
	Surface		X										
071B-035	Natural 60K		X										
	Natural 100K		X										
	Surface		X										
071B-061	Natural 60K		X										
	Natural 100K		X										
	Surface		X										
090B-035	Natural 60K		X										
	Natural 100K		X										
	Surface		X										
090B-046	Natural 60K		X										
	Natural 100K		X										
	Surface 60K/100K		X										
090B-047	Natural 60K		X										
	Natural 100K		X										
	Surface 60K/100K		X										
090B-058	Natural 60K		X										
	Natural 100K		X										
	Surface 60K/100K		X										
112A-024	Natural 60K			X									
	Natural 100K			X									
	Surface 60K/100K			X									
112A-058	Natural 60K			X									
	Natural 100K			X									
	Surface 60K/100K				X								
112B-024	Natural 60K			X									
	Natural 100K				X								
	Surface 60K/100K					X							
112B-048	Natural 60K					X							
	Natural 100K						X						
	Surface 60K/100K							X					
112B-058	Natural 60K					X							
	Natural 100K						X						
	Surface 60K/100K							X					
112C-024	Natural 60K				X								
	Natural 100K					X							
	Surface 60K/100K												
112C-058	Natural 60K								X				
	Natural 100K									X			
	Surface 60K/100K										X		
112D-027	Natural 60K				X								
	Natural 100K					X							
	Surface 60K/100K						X						

Fig. 17-1: Overview of power connector cross-section

INS0680 1,0mm²

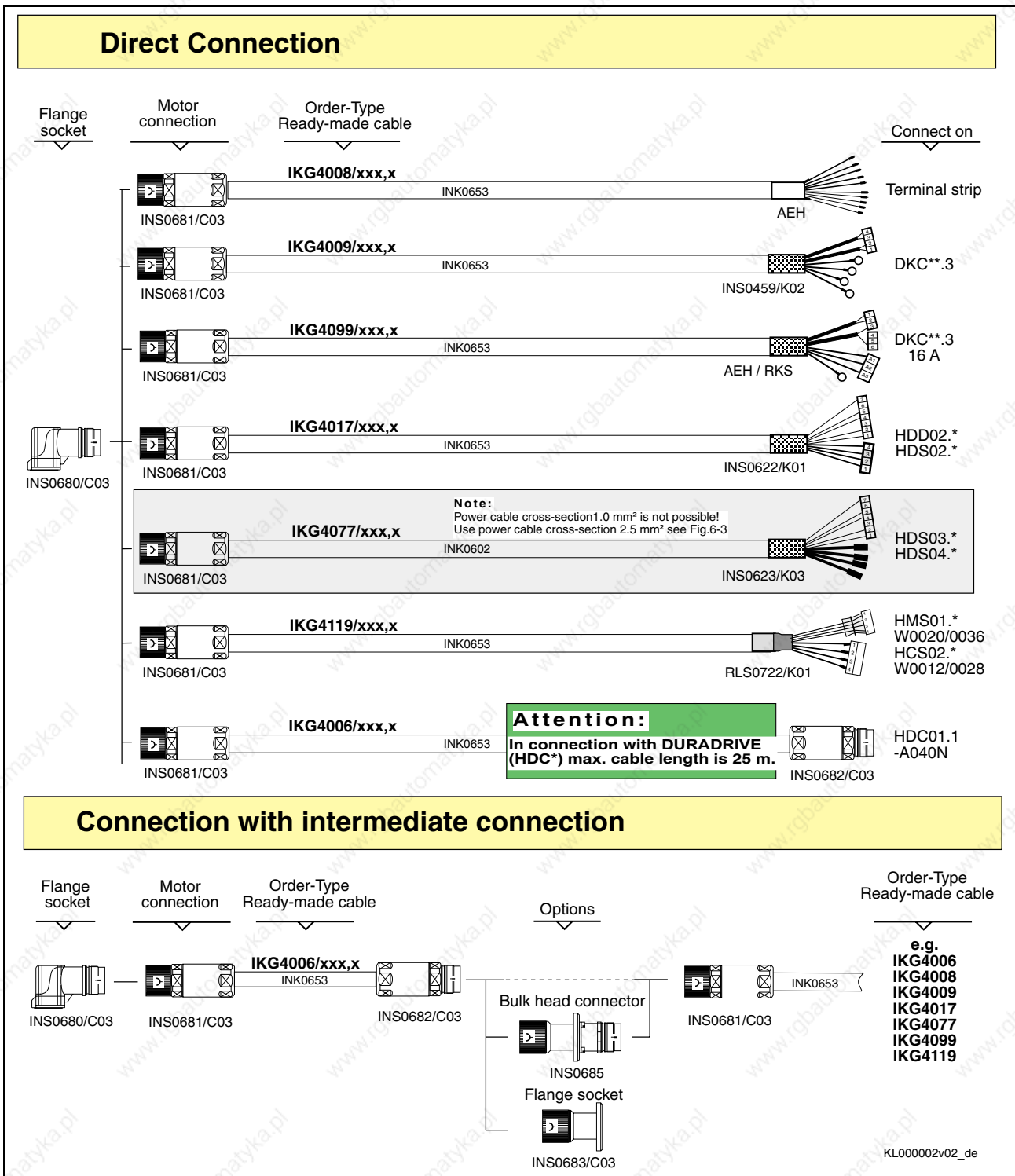

Fig. 17-2: Kabelauswahl INS0680 – 1,0mm²

INS0542 1,0mm²

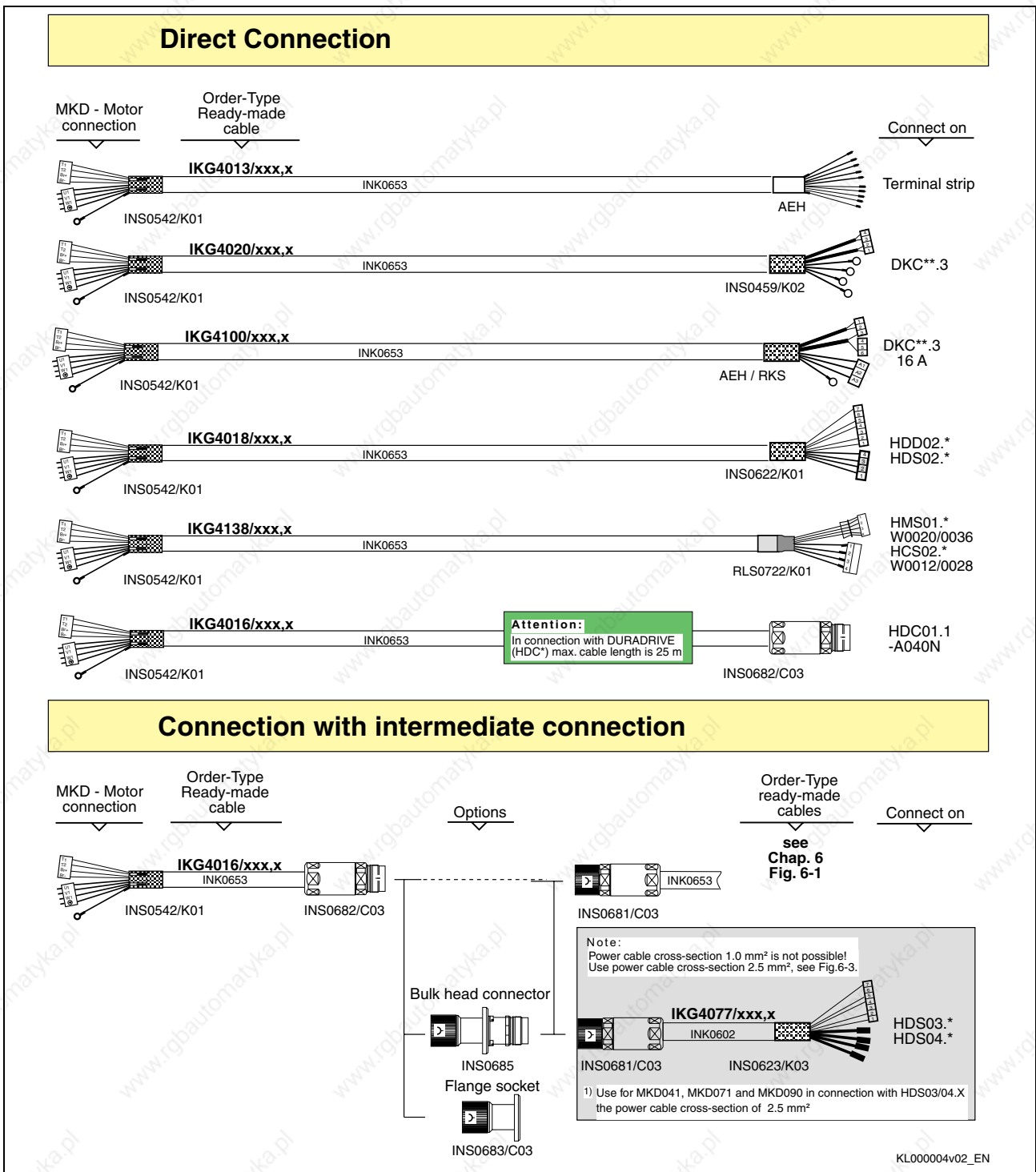

Fig. 17-3: Kabelauswahl INS0542 – 1,0mm²

INS0480 1,5mm²

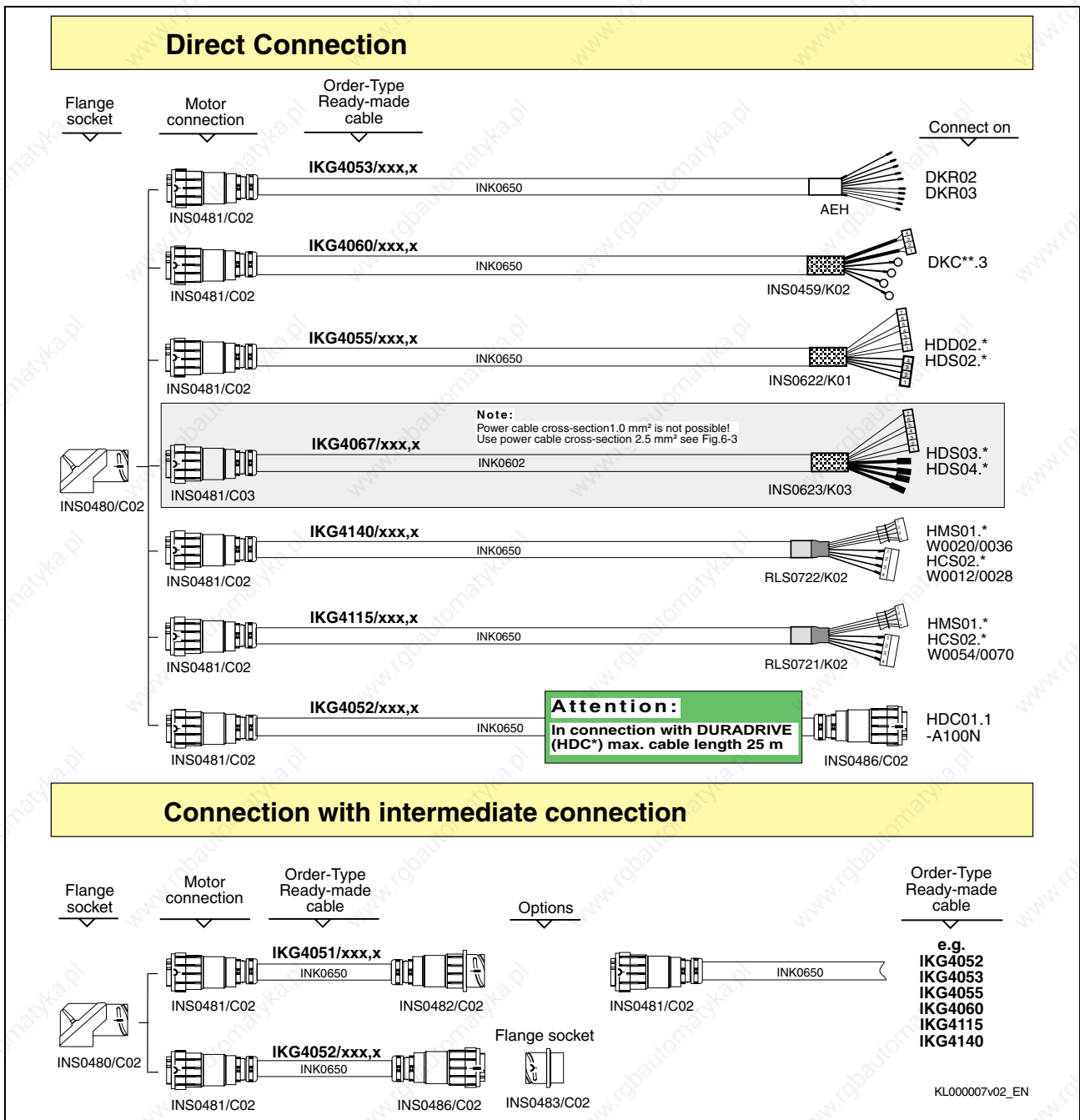

Fig. 17-4: Kabelauswahl INS0480 – 1,5mm²

INS0480 2,5mm²

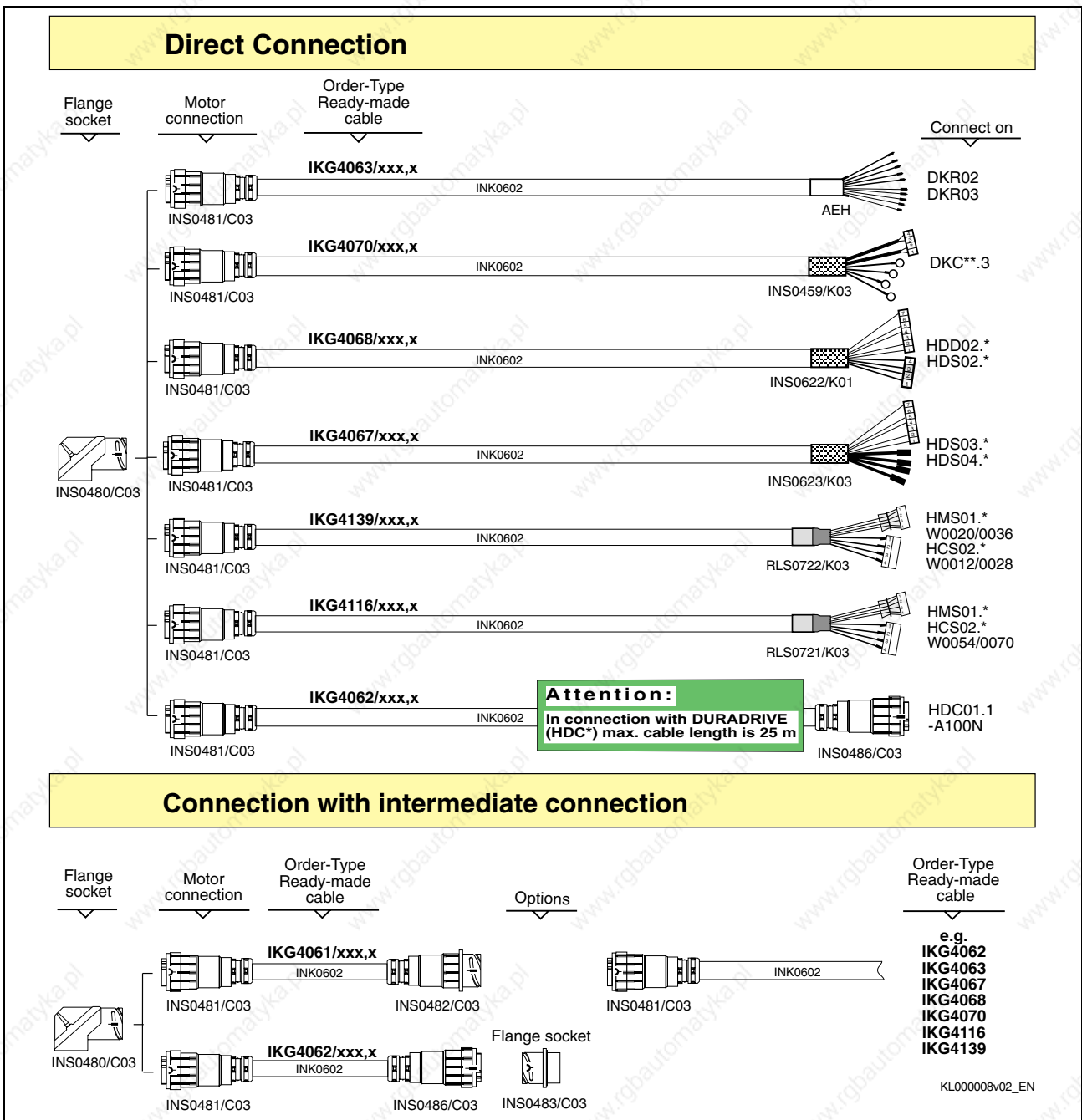

Fig. 17-5: Kabelauswahl INS0480 – 2,5mm²

INS0480 4,0mm²

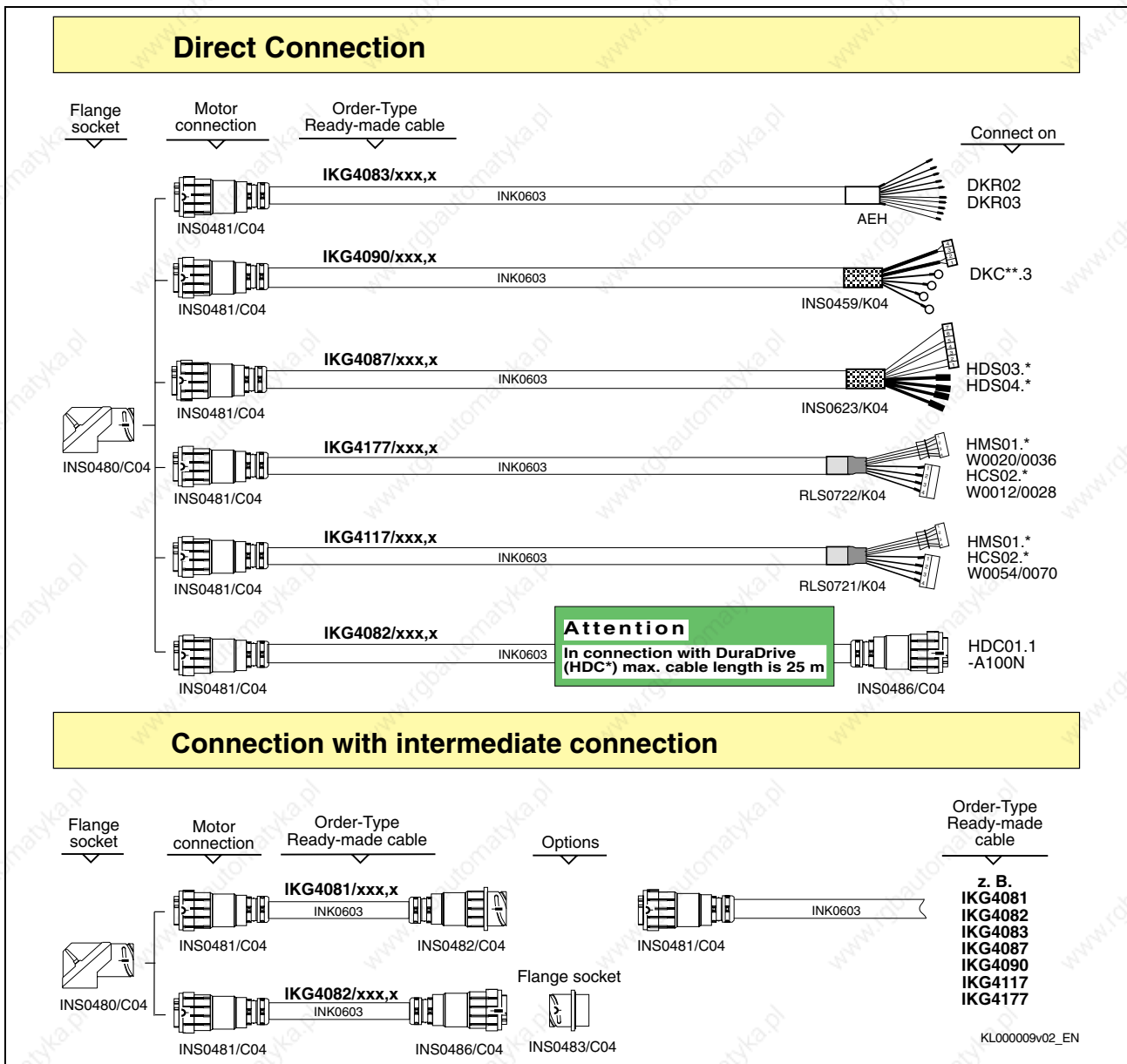

Fig. 17-6: Kabelauswahl INS0480 – 4,0mm²

INS0480 6,0mm²

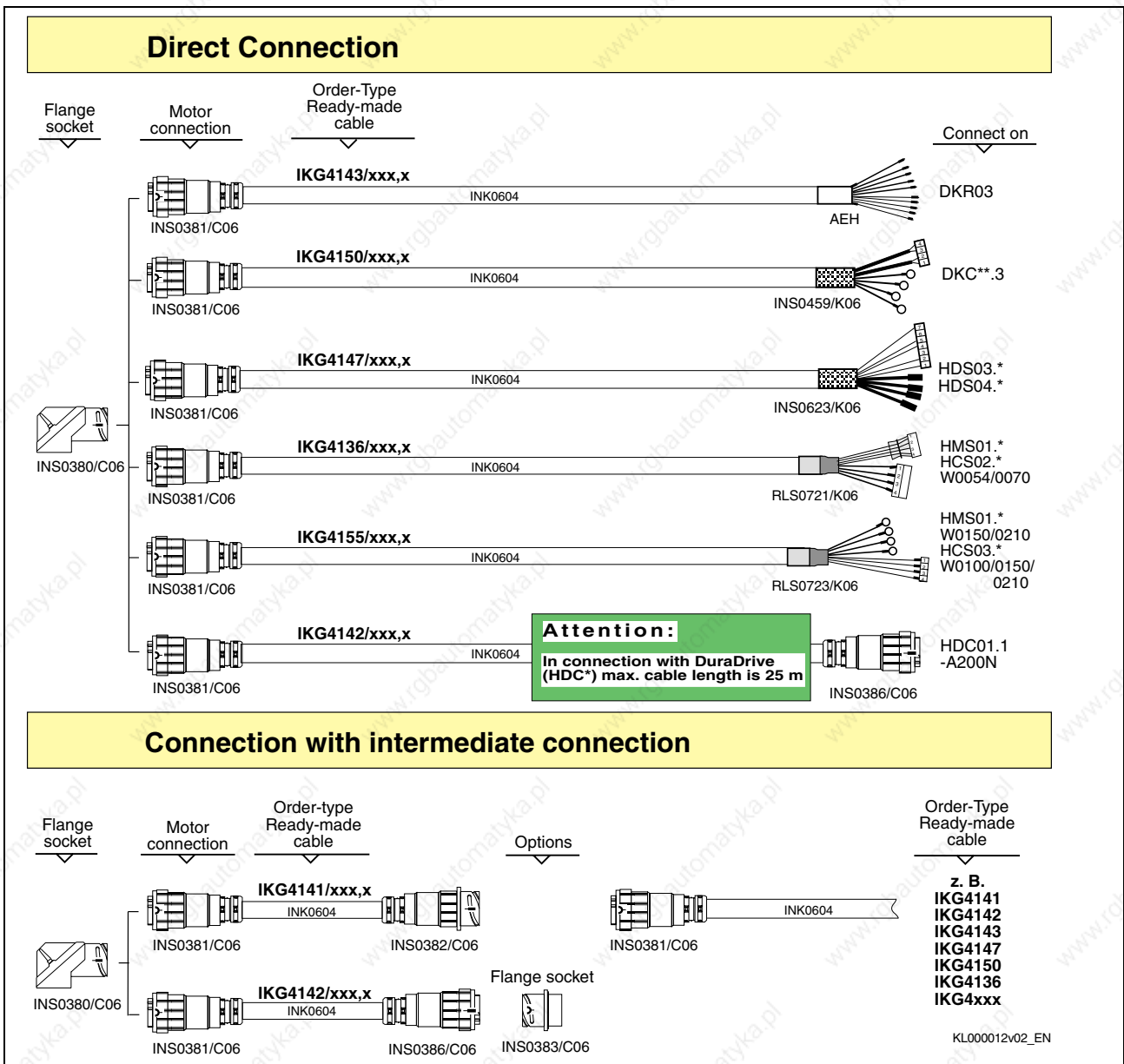

Fig. 17-7: Kabelauswahl INS0480 – 6,0mm²

INS0480 10,0mm²

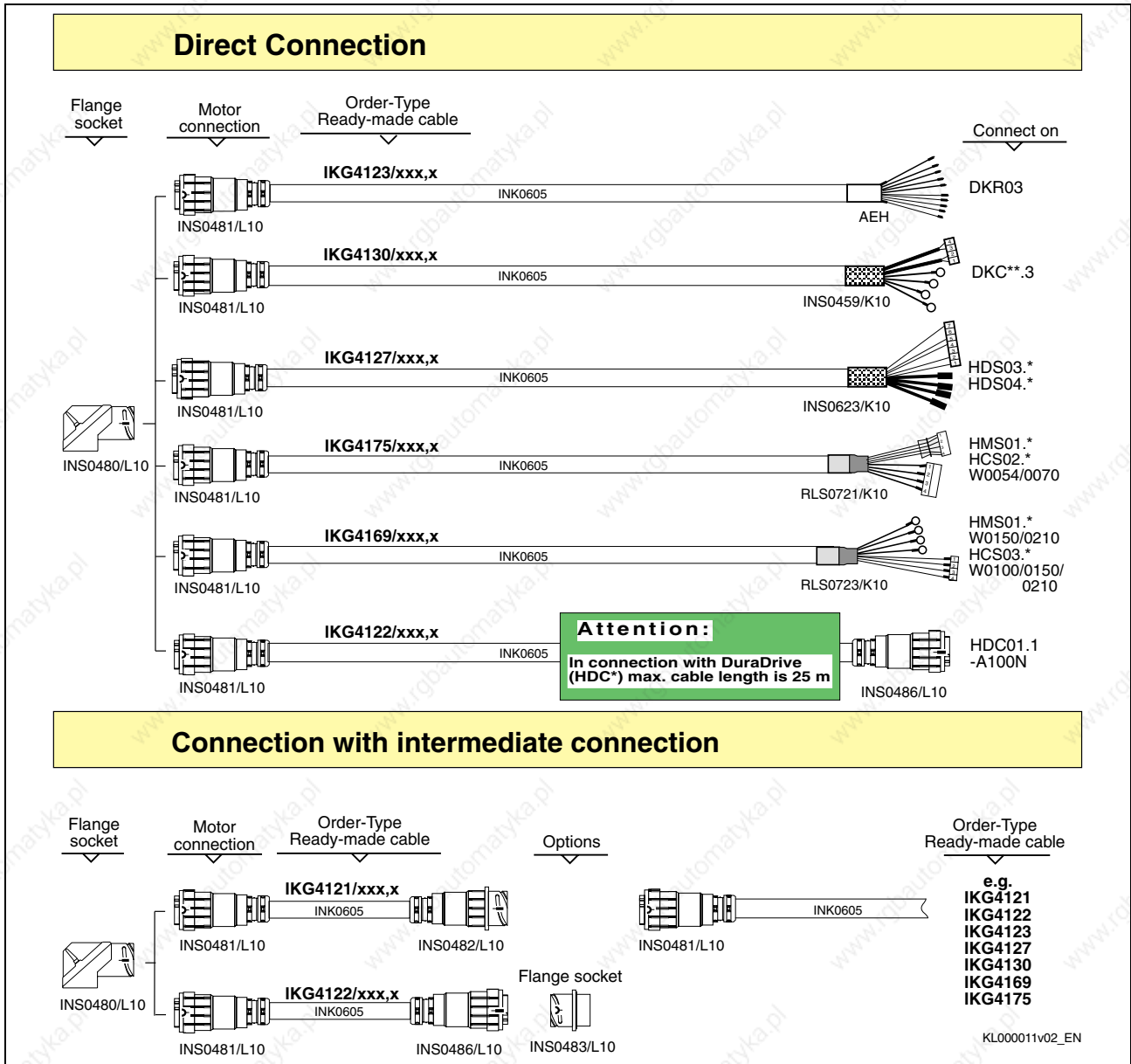

Fig. 17-8: Kabelauswahl INS0480 – 10,0mm²

INS0380 6,0mm²

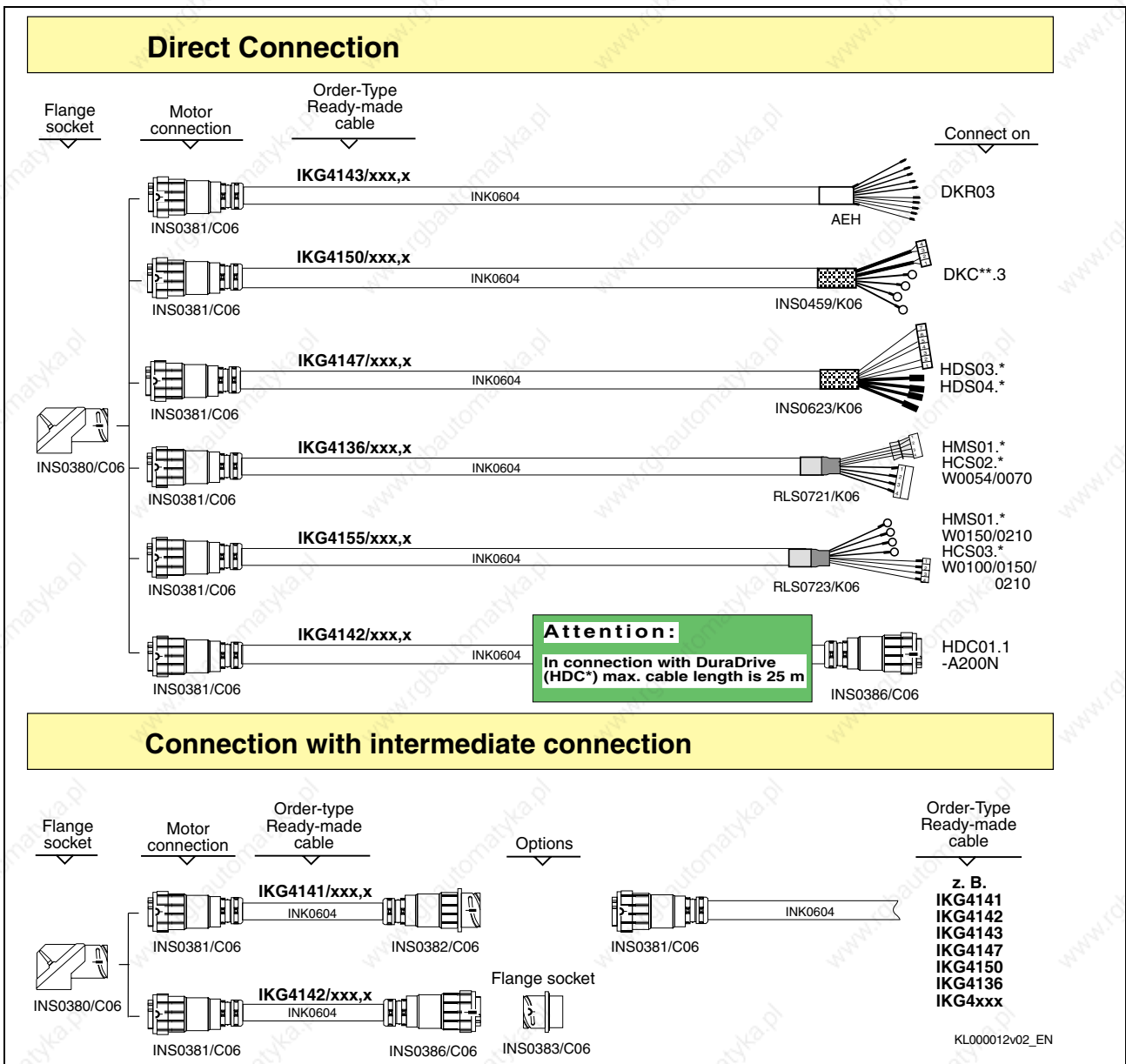

Fig. 17-9: Kabelauswahl INS0380 – 6,0mm²

INS0380 10,0mm²

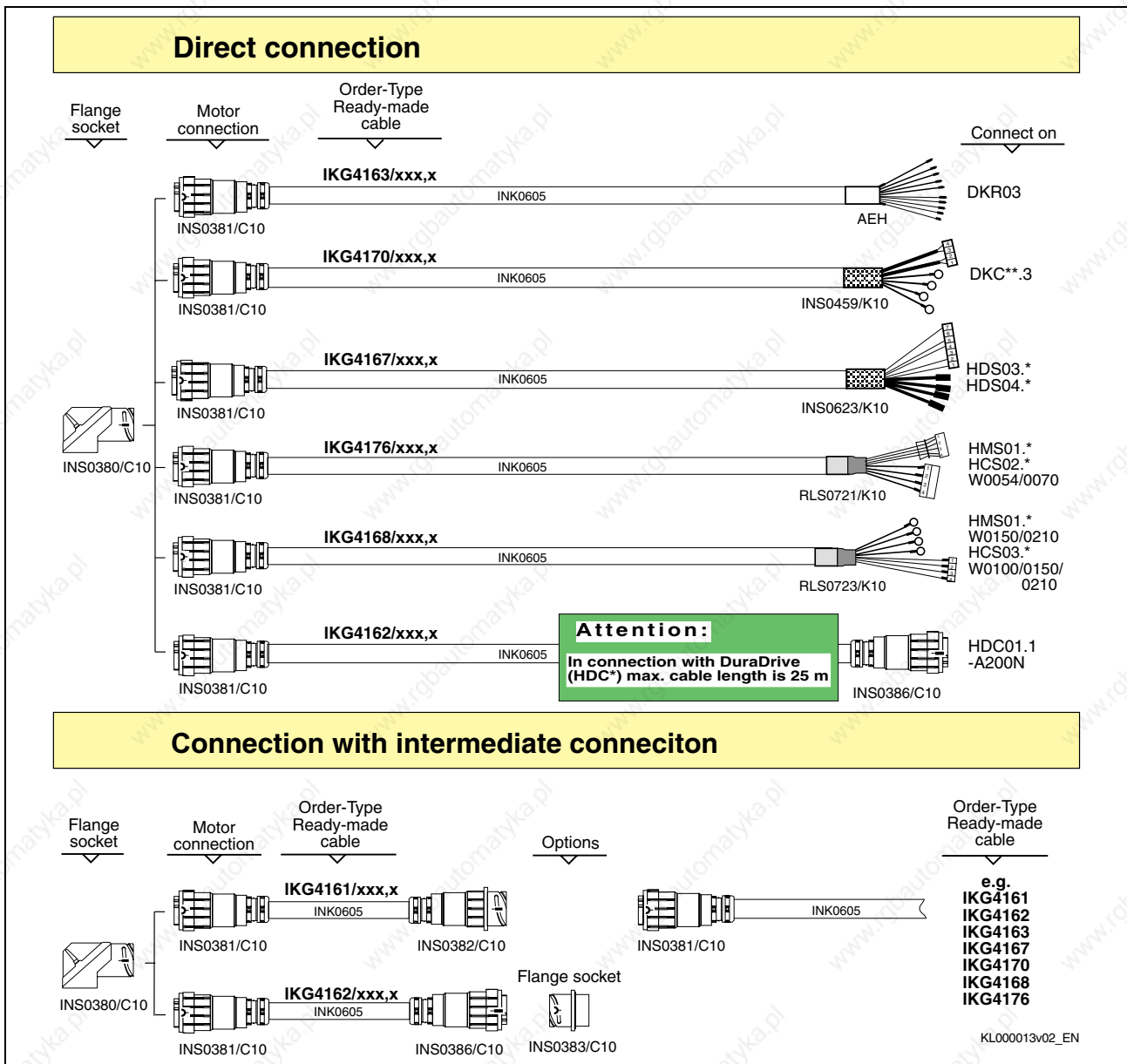

Fig. 17-10: Kabelauswahl INS0380 – 10,0mm²

INS0380 16,0mm²

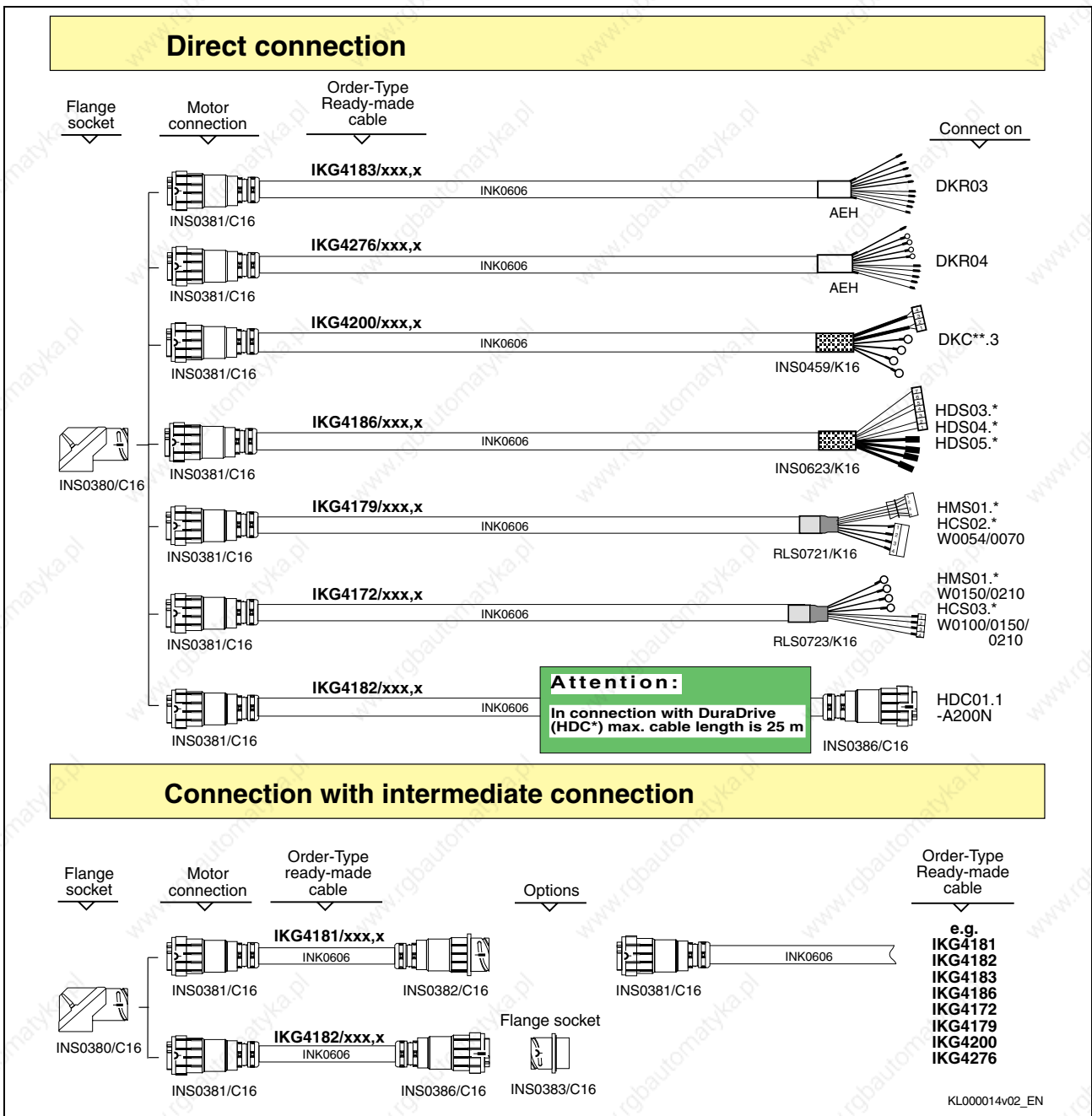

Fig. 17-11: Kabelauswahl INS0380 – 16,0mm²

17.3 Selecting Encoder Cables

Different encoder cables are available for MKD Motors. The tables and graphics represented on the following sides serve for the choice of encoder cables.

Motor	Encoder Cable Connector box	Encoder Cable Connector (straight)	Encoder Cable Connector (angled)	Encoder Cable for REFUDRIVE
MKD025*-***-***-KN	see Fig. 17-13	---	---	see Fig. 17-16
MKD025*-***-***-UN	---	see Fig. 17-14	see Fig. 17-15	see Fig. 17-16
MKD041	see Fig. 17-13	---	---	see Fig. 17-16
MKD071	see Fig. 17-13	---	---	see Fig. 17-16
MKD090	see Fig. 17-13	---	---	see Fig. 17-16
MKD112	---	see Fig. 17-14	see Fig. 17-15	see Fig. 17-16

Fig. 17-12: Selecting Encoder Cables

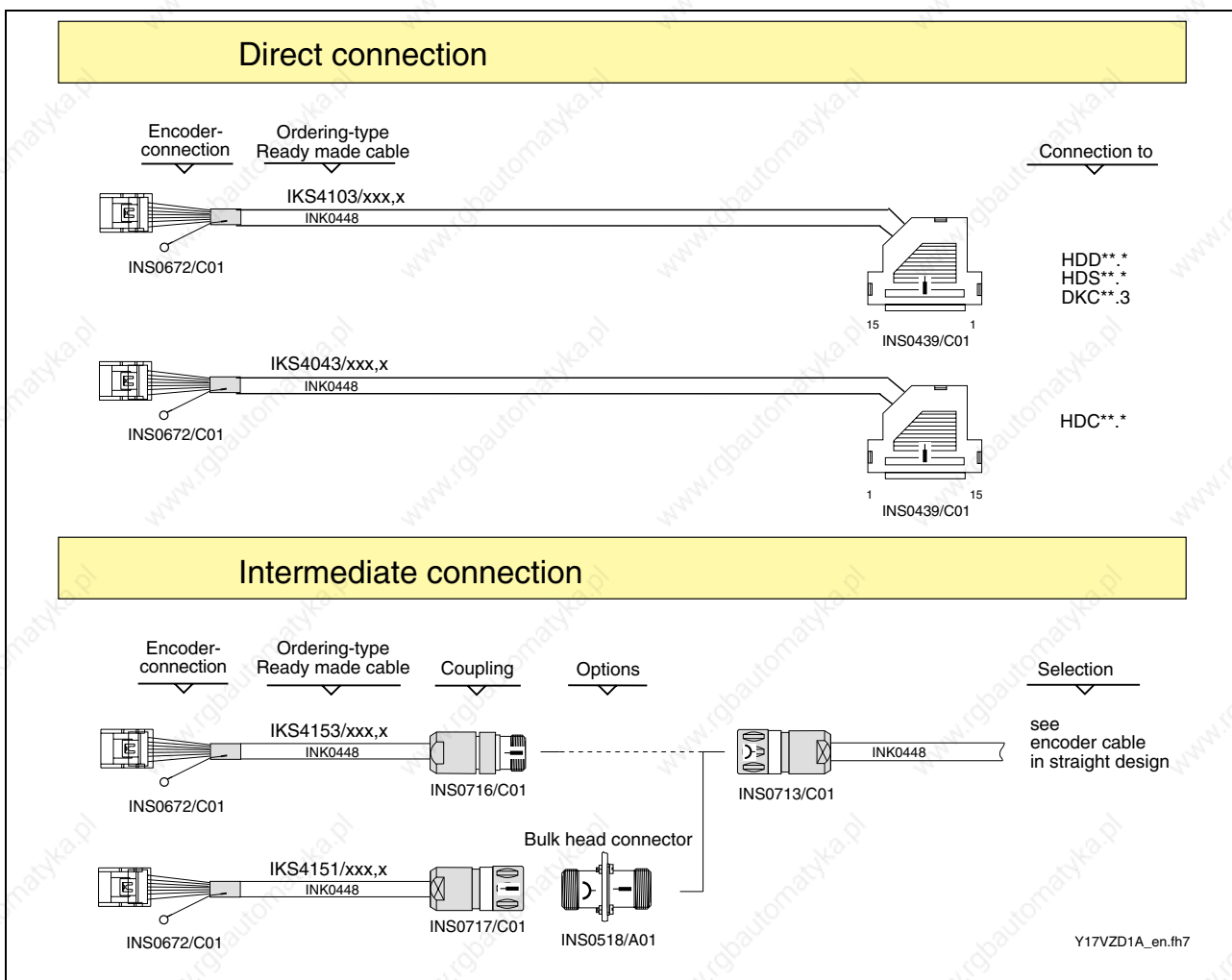

Fig. 17-13: Encoder cable for MKD025, -041, -071, -090 with Connector box

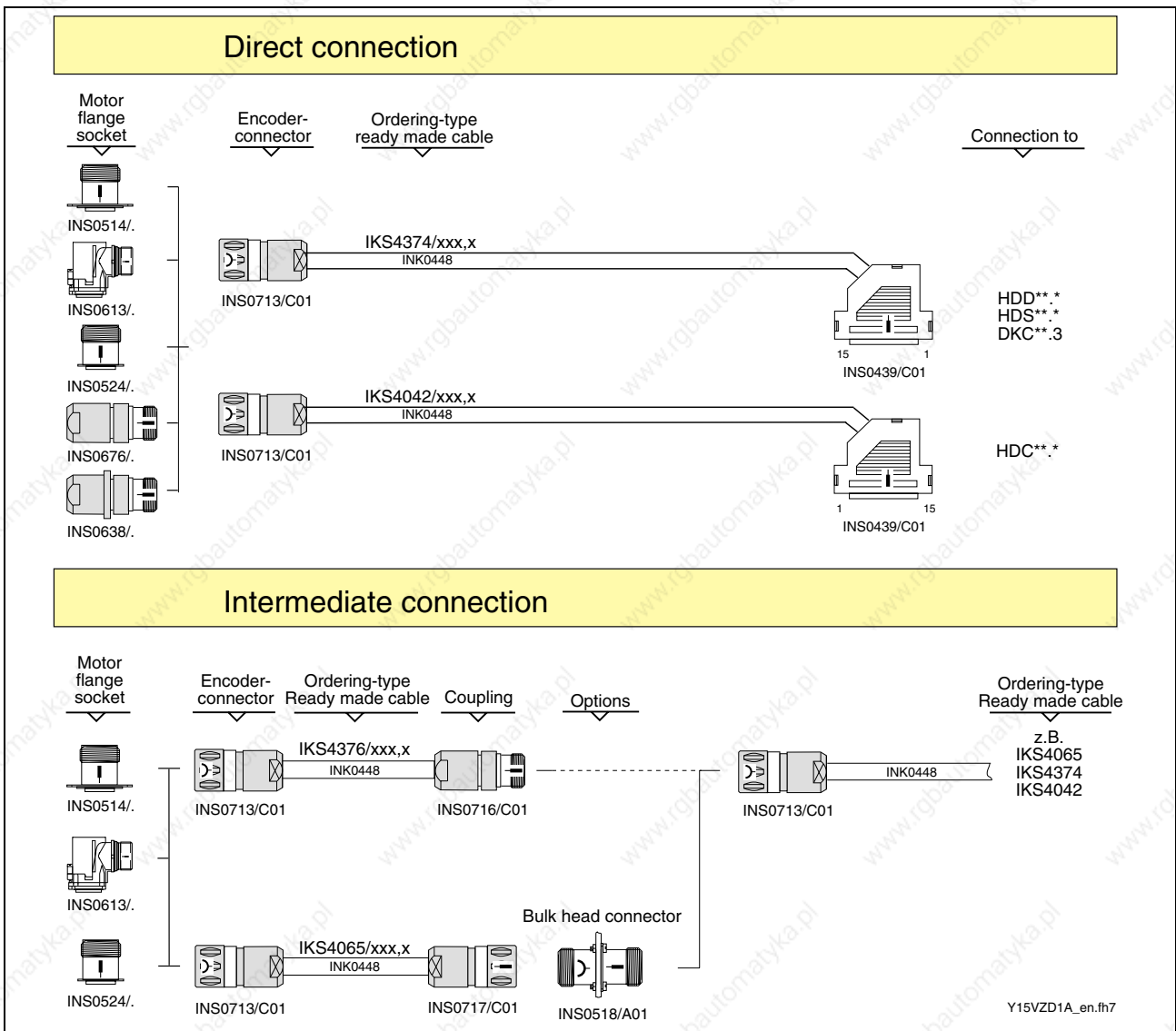

Fig. 17-14: Encoder cable (Connector straight) for MKD025, -112

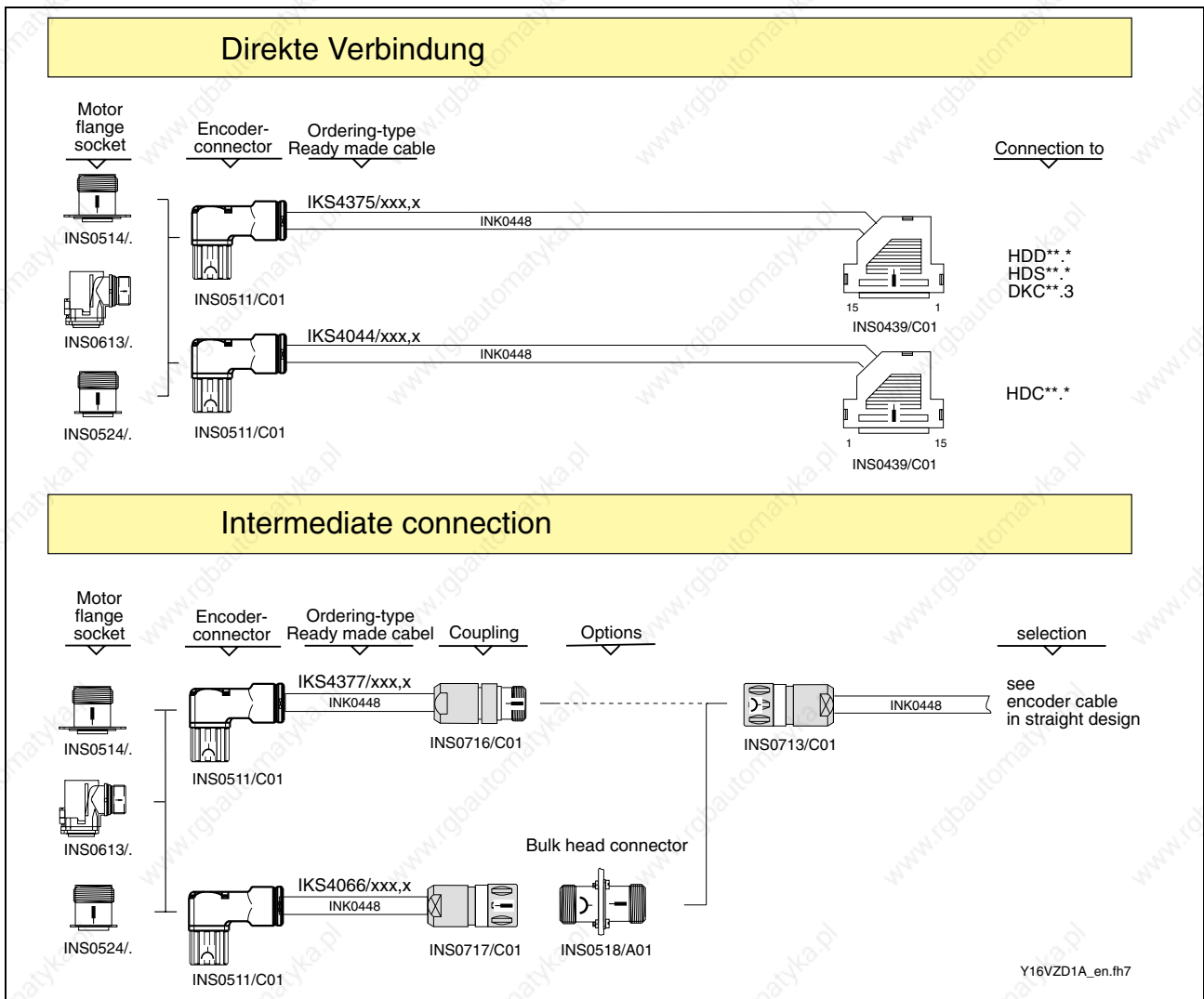

Fig. 17-15: Encoder cable (Connector angled) for MKD025, -112

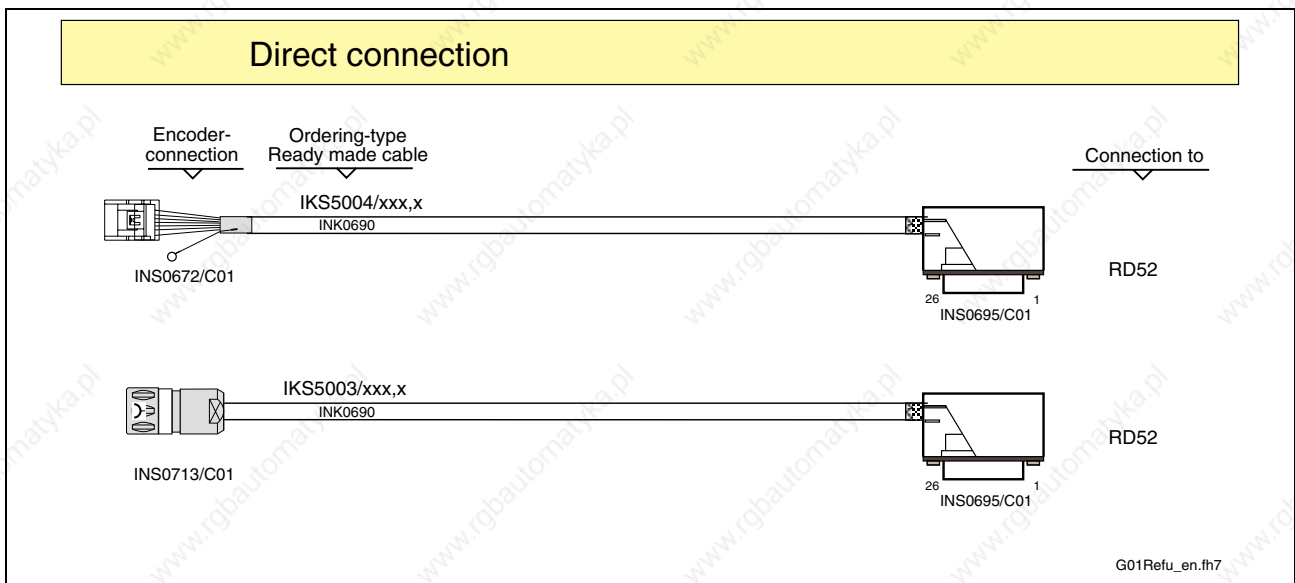

Fig. 17-16: Encoder cable MKD - REFUDRIVE RD52

18 Index

A

Ambient Temperature 13-1

B

Balance 4-3

Bar code label 14-1

Battery

assembling 16-5

changing 16-4

removing 16-4

Blower

Notes on ordering 13-7

C

Cable sets 14-2

Centering diameter 4-2

Characteristic motor speed 5-3

Characteristic voltage limit curves 5-5

commutation 1-1

Commutation 1-3

Connecting the motor

with connection box 15-4

with plug-in connectors 15-6

Connection Cable 16-2

Connection diagram

Motor with connector box 12-2

motors with connector receptacle 12-4

overview 12-1

Connection diagram blower type (1) 12-6

Continuous current at standstill 5-3

Continuous torque at standstill 1-2, 5-3

continuous torques at standstill 1-2

Cooling ribs 16-2

Cycle duration 5-2

Cyclic duration factor 5-2

D

Degree of protection 13-3

Delivery note 14-1

Designs 1-3

Drag chains 16-2

Dynamics 1-1

E

Encoder connector 15-6

Encoder data memory 13-13

Encoder system 4-3

Energy management chains 16-2

F

Fields of application 1-1

Flange size 4-2

G

Gearings 11-2

H

Heat dissipation 16-2
Holding brake 4-3
 grind in 16-3
 principle 13-8
 safety note 13-8
 startup 16-3
 wear and tear 13-8
Housing overtemperature 5-1

I

Identification 14-1
Idle time 5-2
Intended use
 Fields of application 2-2
 Introduction 2-1
 Requirements 2-1

K

Key 13-9

L

Lifting sling belts 14-3
Locking screws 15-2

M

Machine accuracy 5-1
Maintenance-free operation 1-1
Mass 5-4
Maximum speed 5-4
Moment of inertia of the rotor 5-4
Motor
 Design and components 1-3
Motor feedback
 encoder data memory 13-13
Motor feedback (Encoder system) 4-2
Motor frame length 4-2
Motor frame size 4-2
Motor overtemperature
 100-K 5-1
 60-K 5-1
Motor versions
Mounting position 13-6

N

Non-intended use 2-2
 Consequences, disclaimer of liability 2-1
Number of pole pairs 5-3

O

ON time 5-2
Operating modes 5-2
Operation Curve
 S1 5-5
 S6 5-5
Operational reliability 1-1
Order types of the sealing air connectors 11-1
Other performances 4-4
Output direction 4-4
Output Direction of Power Connector 4-4

Output shaft 4-3
 Plain shaft 4-3
 Shaft with keyway 4-3
Outside systems 1-6
Overload capability 1-1
Overload protection 1-1

P

Packing 14-2
Peak current 5-3
Performance data 1-1
Plain shaft 13-9
Planetary Gearings 11-2
Position detection 13-13
Power Cable Dimensioning 12-8
Product group 4-2

R

Radial shaft sealing ring 5-1, 13-10
Rated current 5-3
Rated frequency 5-3
Rated output 5-3
Rated speed 5-3
Rated torque 5-3
Rated voltage 5-3
Redundant bearing 13-12
Running noise 16-2

S

Safety Instructions for Electric Drives and Controls 3-1
Screw Gearings 11-3
Sealing Air 11-1
Sealing air principle 13-4
Setup Height 13-1
Shaft
 plain 13-9
 with key 13-9
 with sealing ring 13-10
Shaft sealing ring 13-10
Shock absorption 14-3
Skilled technical personnel 15-1
Standards 1-6
Startup 16-1

T

Theoretical maximum torque 5-4
Thermal limit curves 5-5
Thermal time constant 5-4
Tightness 13-10
Torque constant 5-3
Type code 4-1

U

Use *See Intended Use and see Non-Intended Use*

V

Vibrations, sinusoidal 13-2
Voltage constant 5-3

W

Winding code 4-2
Winding inductivity 5-3
Winding overtemperature 5-1
Winding resistance 5-3

19 Service & Support

19.1 Helpdesk

Unser Kundendienst-Helpdesk im Hauptwerk Lohr am Main steht Ihnen mit Rat und Tat zur Seite. Sie erreichen uns

- telefonisch: **+49 (0) 9352 40 50 60**
über Service Call Entry Center Mo-Fr 07:00-18:00
- per Fax: **+49 (0) 9352 40 49 41**
- per e-Mail: **service@indramat.de**

Our service helpdesk at our headquarters in Lohr am Main, Germany can assist you in all kinds of inquiries. Contact us

- by phone: **+49 (0) 9352 40 50 60**
via Service Call Entry Center Mo-Fr 7:00 am - 6:00 pm
- by fax: **+49 (0) 9352 40 49 41**
- by e-mail: **service@indramat.de**

19.2 Service-Hotline

Außerhalb der Helpdesk-Zeiten ist der Service direkt ansprechbar unter

oder **+49 (0) 171 333 88 26**
+49 (0) 172 660 04 06

After helpdesk hours, contact our service department directly at

or **+49 (0) 171 333 88 26**
+49 (0) 172 660 04 06

19.3 Internet

Unter www.indramat.de finden Sie ergänzende Hinweise zu Service, Reparatur und Training sowie die **aktuellen** Adressen *) unserer auf den folgenden Seiten aufgeführten Vertriebs- und Servicebüros.



Verkaufsniederlassungen



Niederlassungen mit Kundendienst

Außerhalb Deutschlands nehmen Sie bitte zuerst Kontakt mit unserem für Sie nächstgelegenen Ansprechpartner auf.

*) <http://www.indramat.de/de/kontakt/adressen>

Die Angaben in der vorliegenden Dokumentation können seit Drucklegung überholt sein.

At www.indramat.de you may find additional notes about service, repairs and training in the Internet, as well as the **actual** addresses *) of our sales- and service facilities figuring on the following pages.



sales agencies



offices providing service

Please contact our sales / service office in your area first.

*) <http://www.indramat.de/en/kontakt/adressen>

Data in the present documentation may have become obsolete since printing.

19.4 Vor der Kontaktaufnahme... - Before contacting us...

Wir können Ihnen schnell und effizient helfen wenn Sie folgende Informationen bereithalten:

1. detaillierte Beschreibung der Störung und der Umstände.
2. Angaben auf dem Typenschild der betreffenden Produkte, insbesondere Typenschlüssel und Seriennummern.
3. Tel./Faxnummern und e-Mail-Adresse, unter denen Sie für Rückfragen zu erreichen sind.

For quick and efficient help, please have the following information ready:

1. Detailed description of the failure and circumstances.
2. Information on the type plate of the affected products, especially type codes and serial numbers.
3. Your phone/fax numbers and e-mail address, so we can contact you in case of questions.

19.5 Kundenbetreuungsstellen - Sales & Service Facilities

Deutschland – Germany

vom Ausland: (0) nach Landeskennziffer weglassen!
from abroad: don't dial (0) after country code!

Vertriebsgebiet Mitte Germany Centre Rexroth Indramat GmbH Bgm.-Dr.-Nebel-Str. 2 / Postf. 1357 97816 Lohr am Main / 97803 Lohr Kompetenz-Zentrum Europa Tel.: +49 (0)9352 40-0 Fax: +49 (0)9352 40-4885	SERVICE CALL ENTRY CENTER MO – FR von 07:00 - 18:00 Uhr from 7 am – 6 pm Tel. +49 (0) 9352 40 50 60 service@indramat.de	SERVICE HOTLINE MO – FR von 17:00 - 07:00 Uhr from 5 pm - 7 am + SA / SO Tel.: +49 (0)172 660 04 06 oder / or Tel.: +49 (0)171 333 88 26	SERVICE ERSATZTEILE / SPARES verlängerte Ansprechzeit - extended office time - ♦ nur an Werktagen - only on working days - ♦ von 07:00 - 18:00 Uhr - from 7 am - 6 pm - Tel. +49 (0) 9352 40 42 22
Vertriebsgebiet Süd Germany South Rexroth Indramat GmbH Landshuter Allee 8-10 80637 München Tel.: +49 (0)89 127 14-0 Fax: +49 (0)89 127 14-490	Gebiet Südwest Germany South-West Bosch Rexroth AG Vertrieb Deutschland – VD-BI Geschäftsbereich Rexroth Indramat Regionalzentrum Südwest Ringstrasse 70 / Postfach 1144 70736 Fellbach / 70701 Fellbach Tel.: +49 (0)711 57 61-100 Fax: +49 (0)711 57 61-125	Vertriebsgebiet Ost Germany East Bosch Rexroth AG Beckerstraße 31 09120 Chemnitz Tel.: +49 (0)371 35 55-0 Fax: +49 (0)371 35 55-333	Vertriebsgebiet Ost Germany East Bosch Rexroth AG Regionalzentrum Ost Walter-Köhn-Str. 4d 04356 Leipzig Tel.: +49 (0)341 25 61-0 Fax: +49 (0)341 25 61-111
Vertriebsgebiet West Germany West Bosch Rexroth AG Vertrieb Deutschland Regionalzentrum West Borsigstrasse 15 40880 Ratingen Tel.: +49 (0)2102 409-0 Fax: +49 (0)2102 409-406	Vertriebsgebiet Mitte Germany Centre Bosch Rexroth AG Regionalzentrum Mitte Waldecker Straße 13 64546 Mörfelden-Walldorf Tel.: +49 (0) 61 05 702-3 Fax: +49 (0) 61 05 702-444	Vertriebsgebiet Nord Germany North Bosch Rexroth AG Walsroder Str. 93 30853 Langenhagen Tel.: +49 (0) 511 72 66 57-0 Service: +49 (0) 511 72 66 57-256 Fax: +49 (0) 511 72 66 57-93 Service: +49 (0) 511 72 66 57-95	Vertriebsgebiet Nord Germany North Bosch Rexroth AG Kieler Straße 212 22525 Hamburg Tel.: +49 (0) 40 81 955 966 Fax: +49 (0) 40 85 418 978

Europa (West) - Europe (West)

vom Ausland: (0) nach Landeskennziffer weglassen, **Italien:** 0 nach Landeskennziffer mitwählen
from abroad: don't dial (0) after country code, **Italy:** dial 0 after country code

Austria - Österreich Bosch Rexroth GmbH Bereich Indramat Stachegasse 13 1120 Wien Tel.: +43 (0)1 985 25 40 Fax: +43 (0)1 985 25 40-93	Austria – Österreich Bosch Rexroth G.m.b.H. Gesch.ber. Rexroth Indramat Industriepark 18 4061 Pasching Tel.: +43 (0)7221 605-0 Fax: +43 (0)7221 605-21	Belgium - Belgien Bosch Rexroth AG Electric Drives & Controls Industrielaan 8 1740 Ternat Tel.: +32 (0)2 5830719 - service: +32 (0)2 5830717 Fax: +32 (0)2 5830731 indramat@boschrexroth.be	Denmark - Dänemark BEC A/S Zinkvej 6 8900 Randers Tel.: +45 (0)87 11 90 60 Fax: +45 (0)87 11 90 61
Great Britain – Großbritannien Bosch Rexroth Ltd. Rexroth Indramat Division Broadway Lane, South Cerney Cirencester, Glos GL7 5UH Tel.: +44 (0)1285 863000 Fax: +44 (0)1285 863030 sales@boschrexroth.co.uk service@boschrexroth.co.uk	Finland - Finnland Bosch Rexroth Oy Rexroth Indramat division Ansatie 6 017 40 Vantaa Tel.: +358 (0)9 84 91-11 Fax: +358 (0)9 84 91-13 60	France - Frankreich Bosch Rexroth S.A. Division Rexroth Indramat Avenue de la Trentaine BP. 74 77503 Chelles Cedex Tel.: +33 (0)164 72-70 00 Fax: +33 (0)164 72-63 00 Hotline: +33 (0)608 33 43 28	France - Frankreich Bosch Rexroth S.A. Division Rexroth Indramat 1270, Avenue de Lardenne 31100 Toulouse Tel.: +33 (0)5 61 49 95 19 Fax: +33 (0)5 61 31 00 41
France - Frankreich Bosch Rexroth S.A. Division Rexroth Indramat 91, Bd. Irène Joliot-Curie 69634 Vénissieux – Cedex Tel.: +33 (0)4 78 78 53 65 Fax: +33 (0)4 78 78 53 62	Italy - Italien Bosch Rexroth S.p.A. Via G. Di Vittoria, 1 20063 Cernusco S/N.MI Tel.: +39 02 2 365 270 Fax: +39 02 700 408 252378	Italy - Italien Bosch Rexroth S.p.A. Via Paolo Veronesi, 250 10148 Torino Tel.: +39 011 224 88 11 Fax: +39 011 224 88 30	Italy - Italien Bosch Rexroth S.p.A. Via del Progresso, 16 (Zona Ind.) 35020 Padova Tel.: +39 049 8 70 13 70 Fax: +39 049 8 70 13 77
Italy - Italien Bosch Rexroth S.p.A. Via Mascia, 1 80053 Castellammare di Stabia NA Tel.: +39 081 8 71 57 00 Fax: +39 081 8 71 68 85	Italy - Italien Bosch Rexroth S.p.A. Viale Oriani, 38/A 40137 Bologna Tel.: +39 051 34 14 14 Fax: +39 051 34 14 22	Netherlands – Niederlande/Holland Bosch Rexroth B.V. Kruisbroeksestraat 1 (P.O. Box 32) 5281 RV Boxtel Tel.: +31 (0)411 65 19 51 Fax: +31 (0)411 65 14 83 indramat@hydraudyne.nl	Netherlands - Niederlande/Holland Bosch Rexroth Services B.V. Kruisbroeksestraat 1 (P.O. Box 32) 5281 RV Boxtel Tel.: +31 (0)411 65 19 51 Fax: +31 (0)411 67 78 14
Norway - Norwegen Bosch Rexroth AS Rexroth Indramat Division Berghagan 1 or: Box 3007 1405 Ski-Langhus 1402 Ski Tel.: +47 (0)64 86 41 00 Fax: +47 (0)64 86 90 62 jul.ruud@rexroth.no	Spain - Spanien Bosch Rexroth S.A. División Rexroth Indramat Centro Industrial Santiga Obradors s/n 08130 Santa Perpetua de Mogoda Barcelona Tel.: +34 9 37 47 94 00 Fax: +34 9 37 47 94 01	Spain – Spanien Goimendi S.A. División Rexroth Indramat Parque Empresarial Zuatzu C/ Francisco Grandmontagne no.2 20018 San Sebastian Tel.: +34 9 43 31 84 21 - service: +34 9 43 31 84 56 Fax: +34 9 43 31 84 27 - service: +34 9 43 31 84 60 sat.indramat@goimendi.es	Sweden - Schweden Rexroth Mecman Svenska AB Rexroth Indramat Division - Varuvägen 7 (Service: Konsumentvägen 4, Älfsjö) 125 81 Stockholm Tel.: +46 (0)8 727 92 00 Fax: +46 (0)8 647 32 77
Sweden - Schweden Rexroth Mecman Svenska AB Indramat Support Ekvändan 7 254 67 Helsingborg Tel.: +46 (0) 42 38 88 -50 Fax: +46 (0) 42 38 88 -74	Switzerland West - Schweiz West Bosch Rexroth Suisse SA Département Rexroth Indramat Rue du village 1 1020 Renens Tel.: +41 (0)21 632 84 20 Fax: +41 (0)21 632 84 21	Switzerland East - Schweiz Ost Bosch Rexroth Schweiz AG Geschäftsbereich Indramat Hemrietstrasse 2 8863 Buttikon Tel. +41 (0) 55 46 46 111 Fax +41 (0) 55 46 46 222	

Europa (Ost) - Europe (East)

vom Ausland: (0) nach Landeskenziffer weglassen
from abroad: don't dial (0) after country code

Czech Republic - Tschechien Bosch -Rexroth, spol.s.r.o. Hviezdoslavova 5 627 00 Brno Tel.: +420 (0)5 48 126 358 Fax: +420 (0)5 48 126 112	Czech Republic - Tschechien DEL a.s. Strojírenská 38 591 01 Zdar nad Sázavou Tel.: +420 616 64 3144 Fax: +420 616 216 57	Hungary - Ungarn Bosch Rexroth Kft. Angol utca 34 1149 Budapest Tel.: +36 (1) 364 00 02 Fax: +36 (1) 383 19 80	Poland – Polen Bosch Rexroth Sp.zo.o. ul. Staszica 1 05-800 Pruszków Tel.: +48 22 738 18 00 – service: +48 22 738 18 46 Fax: +48 22 758 87 35 – service: +48 22 738 18 42
Poland – Polen Bosch Rexroth Sp.zo.o. Biuro Poznan ul. Dabrowskiego 81/85 60-529 Poznan Tel.: +48 061 847 64 62 /-63 Fax: +48 061 847 64 02	Rumania - Rumänien Bosch Rexroth Sp.zo.o. Str. Drobety nr. 4-10, app. 14 70258 Bucuresti, Sector 2 Tel.: +40 (0)1 210 48 25 +40 (0)1 210 29 50 Fax: +40 (0)1 210 29 52	Russia - Russland Bosch Rexroth Wjatskaja ul. 27/15 125015 Moskau Tel.: +7-095-785 74 78 +7-095 785 74 79 Fax: +7 095 785 74 77 laura.kanina@boschrexroth.ru	Russia - Russland ELMIS 10, Internationalnaya Str. 246640 Gomel, Belarus Tel.: +375/ 232 53 42 70 Fax: +375/ 232 53 37 69 elmis_ltd@yahoo.com
Turkey - Türkei Bosch Rexroth Otomasyon San & Tic. A.S. Fevzi Cakmak Cad No. 3 34630 Sefaköy Istanbul Tel.: +90 212 541 60 70 Fax: +90 212 599 34 07	Slowenia - Slowenien DOMEL Otoki 21 64 228 Zelezniki Tel.: +386 5 5117 152 Fax: +386 5 5117 225 brane.ozebek@domel.si		

Africa, Asia, Australia – incl. Pacific Rim

vom Ausland: (0) nach Landeskennziffer weglassen!
from abroad: don't dial (0) after country code!

<p>Australia - Australien</p> <p>AIMS - Australian Industrial Machinery Services Pty. Ltd. Unit 3/45 Horne ST Campbellfield , VIC 3061 Melbourne</p> <p>Tel.: +61 (0) 393 590 228 Fax: +61 (0) 393 590 286 Hotline: +61 (0) 419 369 195 terryobrien@aimservices.com.au</p>	<p>Australia - Australien</p> <p>Bosch Rexroth Pty. Ltd. No. 7, Endeavour Way Braeside Victoria, 31 95 Melbourne</p> <p>Tel.: +61 (0)3 95 80 39 33 Fax: +61 (0)3 95 80 17 33 mel@rexroth.com.au</p>	<p>China</p> <p>Shanghai Bosch Rexroth Hydraulics & Automation Ltd. Wai Gao Qiao Free Trade Zone No.122, Fu Te Dong Yi Road Shanghai 200131 - P.R.China</p> <p>Tel.: +86 21 58 66 30 30 Fax: +86 21 58 66 55 23 roger.shi_sh@boschrexroth.com.cn</p>	<p>China</p> <p>Bosch Rexroth (China) Ltd. 15/F China World Trade Center 1, Jianguomenwai Avenue Beijing 100004, P.R.China</p> <p>Tel.: +86 10 65 05 03 80 Fax: +86 10 65 05 03 79</p>
<p>China</p> <p>Bosch Rexroth (China) Ltd. A-5F., 123 Lian Shan Street Sha He Kou District Dalian 116 023, P.R.China</p> <p>Tel.: +86 411 46 78 930 Fax: +86 411 46 78 932</p>	<p>China</p> <p>Bosch Rexroth (Changzhou) Co.Ltd. Guangzhou Repres. Office Room 1014-1016, Metro Plaza, Tian He District, 183 Tian He Bei Rd Guangzhou 510075, P.R.China</p> <p>Tel.: +86 20 8755-0030 +86 20 8755-0011 Fax: +86 20 8755-2387</p>	<p>Hongkong</p> <p>Bosch Rexroth (China) Ltd. 6th Floor, Yeung Yiu Chung No.6 Ind Bldg. 19 Cheung Shun Street Cheung Sha Wan, Kowloon, Hongkong</p> <p>Tel.: +852 22 62 51 00 Fax: +852 27 41 33 44 alexis.siu@boschrexroth.com.hk</p>	<p>India - Indien</p> <p>Bosch Rexroth (India) Ltd. Rexroth Indramat Division Plot. A-58, TTC Industrial Area Thane Turbhe Midc Road Mahape Village Navi Mumbai - 400 701</p> <p>Tel.: +91 (0)22 7 61 46 22 Fax: +91 (0)22 7 68 15 31</p>
<p>India - Indien</p> <p>Bosch Rexroth (India) Ltd. Rexroth Indramat Division Plot. 96, Phase III Peenya Industrial Area Bangalore - 560058</p> <p>Tel.: +91 (0)80 8 39 73 74 Fax: +91 (0)80 8 39 43 45 rexbang@bql.vsnl.net.in</p>	<p>Indonesia - Indonesien</p> <p>PT. Rexroth Wijayakusuma Building # 202, Cilandak Commercial Estate Jl. Cilandak KKO, Jakarta 12560</p> <p>Tel.: +62 21 7891169 (5 lines) Fax: +62 21 7891170 - 71</p>	<p>Japan</p> <p>Bosch Rexroth Automation Corp. Service Center Japan Yutakagaoka 1810, Meito-ku, NAGOYA 465-0035, Japan</p> <p>Tel.: +81 (0)52 777 88 41 +81 (0)52 777 88 53 +81 (0)52 777 88 79 Fax: +81 (0)52 777 89 01</p>	<p>Japan</p> <p>Bosch Rexroth Automation Corp. Rexroth Indramat Division 1F, I.R. Building Nakamachidai 4-26-44, Tsuzuki-ku YOKOHAMA 224-0041, Japan</p> <p>Tel.: +81 (0)45 942 72 10 Fax: +81 (0)45 942 03 41</p>
<p>Korea</p> <p>Bosch Rexroth-Korea Ltd. 1515-14 Dadae-Dong, Saha-Ku Rexroth Indramat Division Pusan Metropolitan City, 604-050 Republic of South Korea</p> <p>Tel.: +82 (0)51 26 00 741 Fax: +82 (0)51 26 00 747 gyhan@rexrothkorea.co.kr</p>	<p>Malaysia</p> <p>Bosch Rexroth Sdn.Bhd. 11, Jalan U8/82 Seksyen U8 40150 Shah Alam Selangor, Malaysia</p> <p>Tel.: +60 (0) 3 78 44 80 00 Fax: +60 (0) 3 78 45 48 00 hockhwa@hotmail.com rexroth1@tm.net.my</p>	<p>Singapore - Singapur</p> <p>Bosch Rexroth SDN BHD. No.11, Jalan Astaka U8/82 Seksyen U8 40150 Shah Alam Selangor Darul Ehsan</p> <p>Tel.: +65 (0) 3 7844 8000 Fax: +65 (0) 3 7845 4800 kenton.peh@boschrexroth.com.sg</p>	<p>South Africa - Südafrika</p> <p>TECTRA Automation (Pty) Ltd. 71 Watt Street, Meadowdale Edenvale 1609</p> <p>Tel.: +27 (0)11 971 94 00 Fax: +27 (0)11 971 94 40 Hotline: +27 (0)82 903 29 23 georgv@tectra.co.za</p>
<p>Taiwan</p> <p>Rexroth Uchida Co., Ltd. No.17, Lane 136, Cheng Bei 1 Rd., Yungkang, Tainan Hsien Taiwan, R.O.C.</p> <p>Tel.: +886 (0)6 25 36 565 Fax: +886 (0)6 25 34 754 indramat@mail.net.tw</p>	<p>Thailand</p> <p>NC Advance Technology Co. Ltd. 59/76 Moo 9 Ramintra road 34 Tharang, Bangkokhen, Bangkok 10230</p> <p>Tel.: +66 2 943 70 62 +66 2 943 71 21 Fax: +66 2 509 23 62 sonkawin@hotmail.com</p>		

Nordamerika – North America

USA Hauptniederlassung - Headquarters Bosch Rexroth Corporation Rexroth Indramat Division 5150 Prairie Stone Parkway Hoffman Estates, IL 60192-3707 Tel.: +1 847 6 45 36 00 Fax: +1 847 6 45 62 01 servicebrc@boschrexroth-us.com repairbrc@boschrexroth-us.com	USA Central Region - Mitte Bosch Rexroth Corporation Rexroth Indramat Division Central Region Technical Center 1701 Harmon Road Auburn Hills, MI 48326 Tel.: +1 248 3 93 33 30 Fax: +1 248 3 93 29 06	USA Southeast Region - Südwest Bosch Rexroth Corporation Rexroth Indramat Division Southeastern Technical Center 3625 Swiftwater Park Drive Suwanee, Georgia 30124 Tel.: +1 770 9 32 32 00 Fax: +1 770 9 32 19 03	USA SERVICE-HOTLINE - 7 days x 24hrs - +1-800-860-1055
USA East Region –Ost Bosch Rexroth Corporation Rexroth Indramat Division Charlotte Regional Sales Office 14001 South Lakes Drive Charlotte, North Carolina 28273 Tel.: +1 704 5 83 97 62 +1 704 5 83 14 86	USA Northeast Region – Nordost Bosch Rexroth Corporation Rexroth Indramat Division Northeastern Technical Center 99 Rainbow Road East Granby, Connecticut 06026 Tel.: +1 860 8 44 83 77 Fax: +1 860 8 44 85 95	USA West Region – West Bosch Rexroth Corporation 7901 Stoneridge Drive, Suite 220 Pleasant Hill, California 94588 Tel.: +1 925 227 10 84 Fax: +1 925 227 10 81	
Canada East - Kanada Ost Bosch Rexroth Canada Corporation Burlington Division 3426 Mainway Drive Burlington, Ontario Canada L7M 1A8 Tel.: +1 905 335 55 11 +1 905 335-41 84 michael.moro@boschrexroth.ca	Canada West - Kanada West Bosch Rexroth Canada Corporation 5345 Goring St. Burnaby, British Columbia Canada V7J 1R1 Tel.: +1 604 205-5777 Fax: +1 604 205-6944 david.gunby@boschrexroth.ca	Mexico Bosch Rexroth S.A. de C.V. Calle Neptuno 72 Unidad Ind. Vallejo 07700 Mexico, D.F. Tel.: +52 5 754 17 11 +52 5 754 36 84 +52 5 754 12 60 Fax: +52 5 754 50 73 +52 5 752 59 43	Mexico Bosch Rexroth S.A. de C.V. Calle Argentina No 3913 Fracc. las Torres 64930 Monterey, N.L. Tel.: +52 8 333 88 34...36 +52 8 349 80 91...93 Fax: +52 8 346 78 71 mario.quiroga@boschrexroth.com.mx

Südamerika – South America

Argentina - Argentinien Bosch Rexroth S.A.I.C. "The Drive & Control Company" Acaassuso 48 41/47 1605 Munro Prov. Buenos Aires Tel.: +54 (0)11 4756 01 40 Fax: +54 (0)11 4756 01 36 victor.jabif@boschrexroth.com.ar	Argentina - Argentinien NAKASE Servicio Tecnico CNC Calle 49, No. 5764/66 1653 Villa Balester Prov. - Buenos Aires Tel.: +54 (0) 11 4768 36 43 Fax: +54 (0) 11 4768 24 13 nakase@usa.net nakase@nakase.com gerencia@nakase.com (Service)	Brazil - Brasilien Bosch Rexroth Ltda. Av. Tégula, 888 Ponte Alta, Atibaia SP CEP 12942-440 Tel.: +55 (0)11 4414 56 92 +55 (0)11 4414 56 84 Fax sales: +55 (0)11 4414 57 07 Fax serv.: +55 (0)11 4414 56 86 alexandre.wittwer@rexroth.com.br	Brazil - Brasilien Bosch Rexroth Ltda. R. Dr.Humberto Pinheiro Vieira, 100 Distrito Industrial [Caixa Postal 1273] 89220-390 Joinville - SC Tel./Fax: +55 (0)47 473 58 33 Mobil: +55 (0)47 9974 6645 prochnow@zaz.com.br
Columbia - Kolumbien Reflutec de Colombia Ltda. Calle 37 No. 22-31 Santafé de Bogotá, D.C. Colombia Tel.: +57 1 368 82 67 +57 1 368 02 59 Fax: +57 1 268 97 37 reflutec@inter.net.co			

Rexroth
Bosch Group

Bosch Rexroth AG
Electric Drives and Controls
P.O. Box 13 57
97803 Lohr, Germany
Bgm.-Dr.-Nebel-Str. 2
97816 Lohr, Germany
Phone +49 (0)93 52-40-50 60
Fax +49 (0)93 52-40-49 41
service.svc@boschrexroth.de
www.boschrexroth.com



R911272495

Printed in Germany
DOK-MOTOR*-MKD*****-PR07-EN-P