

## 0920 PSL 001 – PROFIBUS-DP/V1 Network Adapter



- The 0920 PSL 001 Network Adapter connects the Profibus-DP System to the 9 pin D-sub Connector.
- The 0920 PSL 001 Network Adapter acts as a slave in a master/slave environment.
- that are extended to up to 32 Expansion units for flexibility of node size.
- Each Network Adapter can process a maximum of 1024 digital input and output signals, or 64 analog input and output channels.
- The 0920 PSL 001 Network Adapter has indicators that provide a diagnostic readout (module status, network status, expansion unit status, and field power status).
- PTO conformance tested indicates a verified high level of interoperability with other Profibus products.
- Supports auto baud rate detection up to 12MBaud.
- Set node addresses using rotary switches.

Item	PROFIBUS Adapter Module
Communication Module Interface Specifications	
Redundancy	Not supported
Repeater Control Signal	RS-485 Signal
Freeze mode	Support
Sync mode	Support
Auto baud rate	Support
Fail safe mode	Support
Station type	Slave
FMS support	Not supported
Number of Nodes	100 Node/Max (Rotary switch# 0-99).
Number of Expansion I/O slots	Max. 32 slots
I/O Data Size	Total: Input 128bytes / Output 128bytes <ul style="list-style-type: none"> <li>• Max. Discrete I/O: Input 1024points/Output 1024points</li> <li>• Max. Analog I/O: Input 64channels/Output 64channels</li> </ul>
Indicators	1 green/red Module Status Indicator 1 green Network Status Indicator 1 green/red Expansion Module Status indicator 1 green Field Power Status indicator
Communication Rate	9.6K-12M(1.2Km-100m)
Communication Speed	9.6 to 12000 Kbps (Auto baud rate selection)
Module Location	Starter module - left side of IO system
Field Power monitoring	Detect Field Power @11Vdc
General Specification	
System Power	Supply voltage: 24Vdc nominal Voltage range: 11-28.8Vdc, Protection: Output Current Limit (Min. 1.5A) Reverse polarity protection
Power dissipation	60mA typical @24Vdc
Current for I/O module	1.5A @ 5Vdc maximum
Isolation	System power: Non- isolation / System to Logic: Isolation
Field Power	Supply voltage: 24Vdc nominal / Voltage range: 11-28.8Vdc
Current in jumper contacts	DC 10A max.
Weight	150g
Module Size	42mm x 99mm x 70mm
Environment Condition	Refer to '2. Environment Specification'

## PROFIBUS Connector

Pin No.	Description
3	RxD / TxD - P
4	CNTR-P
5	DGND
6	VP
8	RxD / TxD - N
9	CNTR-N

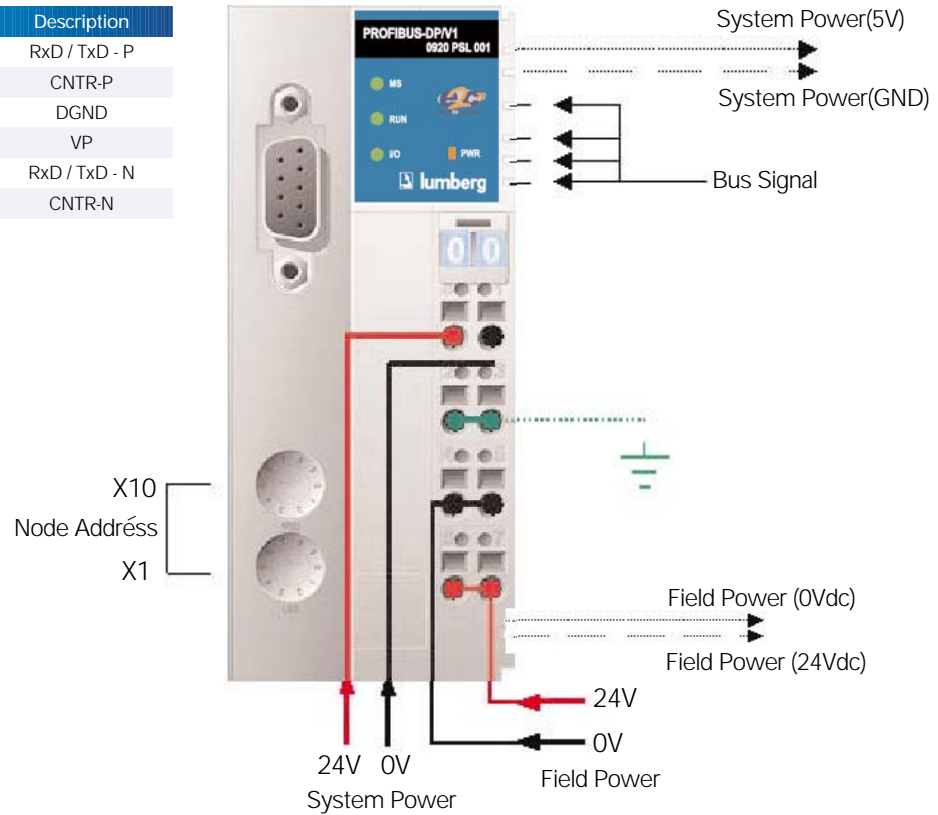

## Status Indicator LED

### Module Status LED

No Power	Off	No power is supplied to the unit.
Device Operational	Green	The unit is operating in normal condition.
Unrecoverable Fault	Red	The unit has incurred an unrecoverable fault in self-testing. - Invalid Module ID - Firmware fault - Hardware fault

### Network Status LED

Not Powered baud rate Search mode & No Data exchange mod	Off	Device is in baud rate search mode or may not be powered.
No baud rate Search mode & No Data exchange mode	Flashing Green	Device has searched the baud rate and that are parameterized by the master. ; there is no cyclic user data exchange. Wait for Parameter telegram. Parameter fault. Wait for configuration telegram. Configuration fault.
Data exchange mode	Green	Device is in cyclic data exchange mode with the parameterization master.

## Expansion Module Status LED(IO)

State	LED is	To Indicates:
Not Powered No Expansion Module	Off	Device has no expansion module or may not be powered
Bus Connection, Run Exchanging IO	Green	Bus in Normal Operation
Expansion Configuration Failed	Flashing Red	Failed to initialize expansion module - Detected invalid expansion module ID. - Overflowed Input/Output Size - Too many expansion modules - Initial protocol failure
Bus connection fault During exchanging IO	Red	One or more expansion modules active in fault state. - Changed expansion module configuration. - Bus communication failure.

## Field Power Status LED

State	LED is	To Indicates:
Not Supplied Field Power	Off	Not supplied 24V dc field power
Supplied Field Power	Green	Supplied 24V dc field power

## Mapping Data into the Image Table

