

PIN CONFIGURATION

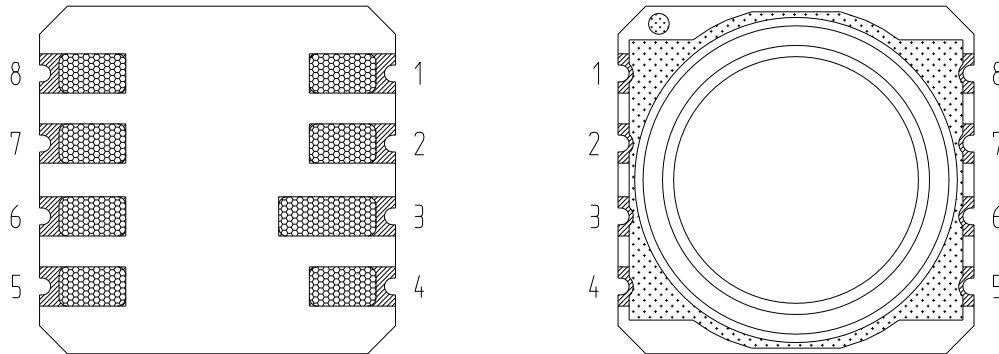

Fig. 2: Pin configuration of MS5540C

| Pin Name | Pin | Type | Function |
|----------|-----|------|------------------------------|
| SCLK | 1 | I | Serial data clock |
| GND | 2 | G | Ground |
| PV (1) | 3 | N | Negative programming voltage |
| PEN (1) | 4 | I | Programming enable |
| VDD | 5 | P | Positive supply voltage |
| MCLK | 6 | I | Master clock (32.768 kHz) |
| DIN | 7 | I | Serial data input |
| DOUT | 8 | O | Serial data output |

NOTE

- 1) Pin 3 (PV) and Pin 4 (PEN) are only used by the manufacturer for calibration purposes and should not be connected.

ABSOLUTE MAXIMUM RATINGS

| Parameter | Symbol | Conditions | Min | Max | Unit | Notes |
|---------------------|-----------------|------------------------|------|-----|------|-------|
| Supply voltage | V _{DD} | T _a = 25 °C | -0.3 | 4 | V | |
| Storage temperature | T _s | | -40 | +85 | °C | 1 |
| Overpressure | P | T _a = 25 °C | | 10 | bar | 2 |

NOTES

- 1) Storage and operation in an environment of dry and non-corrosive gases.
- 2) The MS5540C is qualified referring to the ISO 2281 standard and can withstand an absolute pressure of 11 bar in salt water or 100 m water respectively.

RECOMMENDED OPERATING CONDITIONS

(Ta = 25 °C, V_{DD} = 3.0 V unless noted otherwise)

| Parameter | Symbol | Conditions | Min | Typ | Max | Unit |
|--|--|-------------------------|--------|--------|--------|----------------|
| Operating pressure range | p | | 10 | | 1100 | mbar abs. |
| Supply voltage | V _{DD} | | 2.2 | 3.0 | 3.6 | V |
| Supply current, average (1) during conversion (2) standby (no conversion) | I _{avg} I _{sc} I _{ss} | V _{DD} = 3.0 V | | 4 1 | 0.1 | μA mA μA |
| Current consumption into MCLK (3) | | MCLK = 32.768 kHz | | | 0.5 | μA |
| Operating temperature range | T | | -40 | | +85 | °C |
| Conversion time | t _{conv} | MCLK = 32.768 kHz | | | 35 | ms |
| External clock signal (4) | MCLK | | 30.000 | 32.768 | 35.000 | kHz |
| Duty cycle of MCLK | | | 40/60 | 50/50 | 60/40 | % |
| Serial data clock | SCLK | | | | 500 | kHz |

NOTES

- 1) Under the assumption of one conversion every second. Conversion means either a pressure or a temperature measurement started by a command to the serial interface of MS5540C.
- 2) During conversion the sensor will be switched on and off in order to reduce power consumption; the total on time within a conversion is about 2 ms.
- 3) This value can be reduced by switching off MCLK while MS5540C is in standby mode.
- 4) It is strongly recommended that a crystal oscillator be used because the device is sensitive to clock jitter. A square-wave form of the clock signal is a must.