

# AC Main Spindle Drives with Controlled Asynchronous Motors and Frameless Spindle Motors

Applications Manual

DOK-DIAX01-MAIN+2AD+1M-ANW1-EN-P





Section

About this Documentation

---

Table of Contents

---

Commissioning 1

---

Operating the Controllers 2

---

Controller Functions 3

---

Diagnostics and Fault Clearance 4

---

Summary of Parameters 5

---

Overview of Interfaces and Associated Functions 6

---

Index 7

---

Abbreviations and Agreements, Type Codes 8

---

Supplementary Documentation 9

---



**Titel** AC Main Spindle Drives with Controlled Asynchronous Motors and Frameless Spindle Motors

**Type of documentation:** Applications Manual

**Documenttype** DOK-DIAX01-MAIN+2AD+1M-ANW1-EN-E1,44

**Internal file reference** • 209-0041-4109-01

**Reference** This electronic document is based on the hardcopy document with document desig.: 209-0041-4109-01 EN/06.93

**This documentation is used:** This documentation

- Assists in the commission of AC main spindle drives used in module systems with KDA/TDA or complete systems with RAC.
- Explains how to operate the controllers.
- Clarifies the technical background specific to the applications and the technical conversion of the main spindle drive functions. Complex functions are graphically illustrated where necessary.
- Explains the diagnostics of the main spindle drives and can be used as a reference when clearing faults.

This documentation:

- Offers safety guidelines on how to handle Indramat drives.
- Summarizes drive parameters and functional interfaces.
- Can be used as a reference when setting the parameters of the drive at the time of delivery and to agree with the machine (parameter protocols).

**Change procedures**

Designation of documentation up to present edition	Release-date	Coments
209-0041-4109-01 EN/06.93	Jun/93	Release
DOK-DIAX01-MAIN+2AD+1M-ANW1-EN-E1,44	Jul./97	First E-Dok

**Copyright** © INDRAMAT GmbH, 1992  
 Copying of this document, and giving it to others and the use or communication of the contents thereof, are forbidden without express authority. Offenders are liable to the payment of damages.  
 All rights are reserved in the event of the grant of a patent or the registration of a utility model or design. (DIN 34-1)

The electronic documentation (E-doc) may be copied as often as needed if such are to be used by the consumer for the purpose intended.

**Validity** All rights reserved with respect to the content of this documentation and the availability of the products.

**Publisher** INDRAMAT GmbH • Bgm.-Dr.-Nebel-Straße 2 • D-97816 Lohr  
 Telefon 0 93 52 / 40-0 • Tx 689421 • Fax 0 93 52 / 40-48 85

Dept ENA (MR, FS)

## Documentation summary "AC main spindle drives with controlled ...

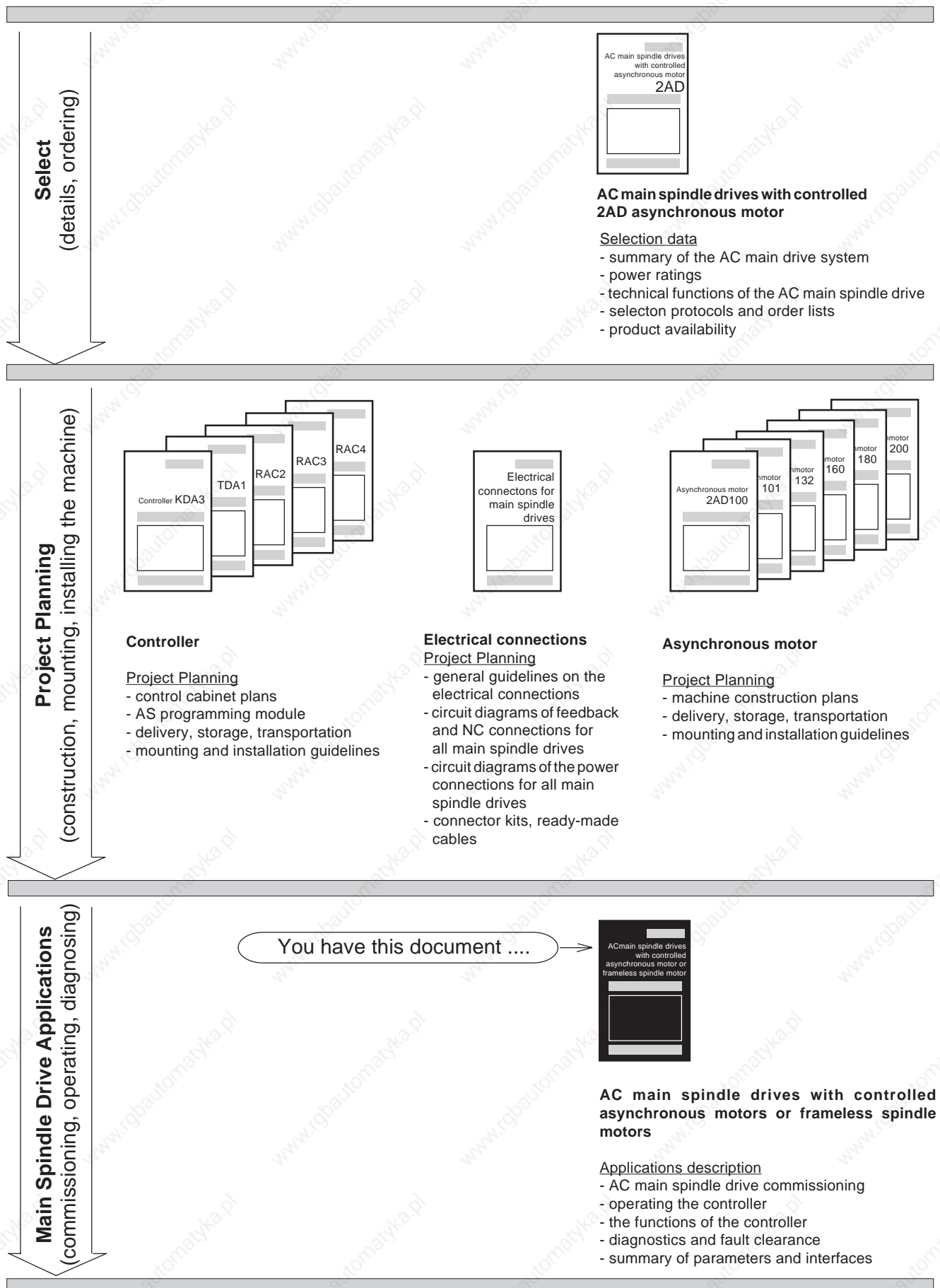
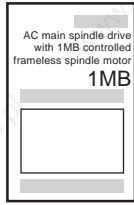

Figure 1: Documentation summary

## ... asynchronous motor or frameless spindle motor"



### AC spindle drive with 1MB controlled frameless spindle motor

#### Selection data

- summary of the AC main drive system
- power ratings
- technical functions of the AC main spindle drive
- selection protocols and order lists
- product availability

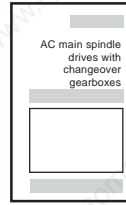

### AC main spindle drives with 2AD controlled asynchronous motor and changeover 2K planetary gearboxes

#### Selection data

- summary of the AC main drive system
- power ratings
- order guidelines

**Select**  
(details, ordering)

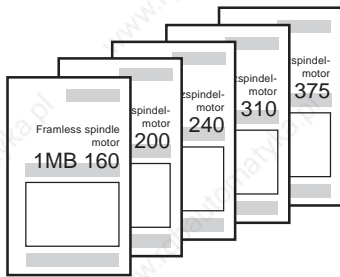

### Frameless spindle motor

#### Project Planning

- machine construction plans
- integrating into the cooling system
- electrical and coolant connections
- delivery

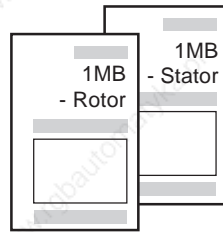

#### Mounting guidelines

- delivery, handling, transport
- mounting
- cooling guidelines

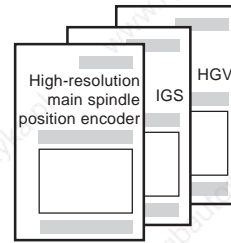

### Supplementary documentation

- high-resolution main spindle position encoder
- incremental encoder output IGS
- high-resolution encoder branching HGV

**Project Planning**  
(construction, mounting, installing the machine)

**Main Spindle Drive Applications**  
(commissioning, operating, diagnosing)



# Contents

<b>1.</b>	<b>Commissioning INDRAMAT AC Main Spindle Drives</b>	<b>13</b>
1.1	Summary of Main Spindle Drive Systems.....	13
1.2	Safety Guidelines .....	16
1.2.1	Notes on Protecting Personnel .....	16
1.2.2	Guidelines on Protecting Equipment.....	17
1.2.3	Guidelines on Protecting the Machine .....	17
1.3	The Equipment Required .....	18
1.4	Main Spindle Drives with KDA or TDA .....	19
1.4.1	Mains Supply Requirements .....	19
1.4.2	Checks with the Equipment Switched Off .....	19
1.4.3	Checks with the Signal Conditioning Powered Up.....	20
1.4.4	Checks after the Power Infeed has been Connected .....	21
1.4.5	Initial Start-Up .....	22
1.5	Main Spindle Drives with RAC Controllers .....	23
1.5.1	Mains Requirements .....	23
1.5.2	Checks with the Equipment Switched-Off .....	23
1.5.3	Checks with Mains Supply Connected/Power Circuits .....	24
	Disconnected .....	24
1.5.4	Connecting the Power Infeed.....	26
1.5.5	Initial Start-Up .....	26
<b>2.</b>	<b>Operating the Controllers</b>	<b>27</b>
2.1	The Control Panel .....	27
2.2	Main Spindle Drive in Operating Mode .....	28
2.2.1	Displaying the Internal State Variables of the Drive.....	29
2.2.2	Outputting the Drive Internal State Variables for Analogue Output N .....	29
2.3	The Main Spindle Drive in Parameter Mode .....	31
2.3.1	Parameter Value Quick-Check .....	31
2.3.2	Reading the Parameters .....	32
2.3.3	Changing the Parameters .....	33
2.3.4	Displaying the Software Version .....	35
2.3.5	Duplicating the Parameters.....	35
2.3.6	Loading Operating Parameters via Serial Interface .....	36
<b>3.</b>	<b>Controller Functions</b>	<b>37</b>
3.1	Drive "Ready" State .....	37
3.2	Speed Command Value .....	38
3.2.1	Analogue Speed Command Value (option).....	38
3.2.2	Digital Speed Command Value (option).....	41
3.3	Main Spindle Speed Signals .....	44

3.4	Speed Command Value Ramps .....	45
3.5	Command Value Smoothing .....	48
3.6	Spindle Positioning .....	50
3.6.1	Basic Data for Spindle Positioning .....	52
3.6.2	Spindle Positioning via Motor Feedback .....	56
3.6.3	Spindle Positioning via Motor Feedback with Spindle Reference Switch .....	57
3.6.4	Spindle Positioning via Spindle Feedback .....	60
3.7	Speed Controller Functions .....	62
3.8	C-Axis Function .....	64
3.9	Power and Torque Limits .....	67
3.10	Drive Utilization Output .....	69
3.10.1	Analogue output for drive utilization (analogue output M) .....	69
3.10.2	Signal output with adjustable threshold for drive utilization (LOAD LIMIT) .....	73
3.11	Temperature Pre-Warning .....	74
3.12	Maximum Spindle Speed .....	75
3.13	Spindle Monitor .....	76
3.14	Switchable Parameter Records .....	77
3.15	Gear Change .....	79
3.15.1	Automatic Gear Change via the Controller .....	79
3.15.2	Gear Change via an External Controller .....	83
3.16	Two-Motor Changeover .....	85
3.17	Master-Slave Operation .....	88
3.18	EMERGENCY-STOP circuit (RAC) .....	92
3.19	Performance during mains failure (RAC) .....	93
3.20	Performance during mains failure and E-stop (KDA, TDA) .....	95
3.21	Starting lockout in KDA/TDA .....	96
3.22	Serial Interface (option) – in preparation .....	97
3.23	SERCOS interface (option) - in preparation .....	97
3.24	Incremental Encoder Output (option) – see Section 9 .....	97
<b>4.</b>	<b>Diagnostics and Fault Clearance</b> .....	<b>98</b>
4.1	Operating Status Diagnostics .....	98
4.2	Fault Diagnostics .....	100
<b>5.</b>	<b>Overview of Parameters</b> .....	<b>106</b>

5.1	General Parameters (A Parameters) .....	106
5.2	Switchable parameter records (P,Q,R,S parameters) .....	109
5.3	Motor Parameters (M Parameters) .....	111
5.4	Parameter Protocol and Additions List .....	113
<b>6.</b>	<b>Interfaces for the NC Controller and Feedback</b>	<b>116</b>
6.1	Controller Inputs, Signal and Analogue Outputs, Bb Contact .....	116
6.2	Analogue Speed Command Value •10V (option) .....	118
6.3	Digital Speed Command Value (option) .....	119
6.4	SERCOS Interface (option) .....	120
6.5	Digital Position Command Value (option) .....	121
6.6	Incremental Encoder Output (option) .....	122
6.7	Serial Interface (option) .....	123
6.8	Motor Feedback Connection .....	124
6.9	Additional Encoder Input (option) .....	125
<b>7.</b>	<b>Index</b>	<b>126</b>
<b>8.</b>	<b>Abbreviations, Agreements, Type Codes</b>	<b>136</b>
<b>9.</b>	<b>Supplementary documentation</b>	<b>144</b>



# 1. Commissioning INDRAMAT AC Main Spindle Drives

## 1.1 Summary of Main Spindle Drive Systems

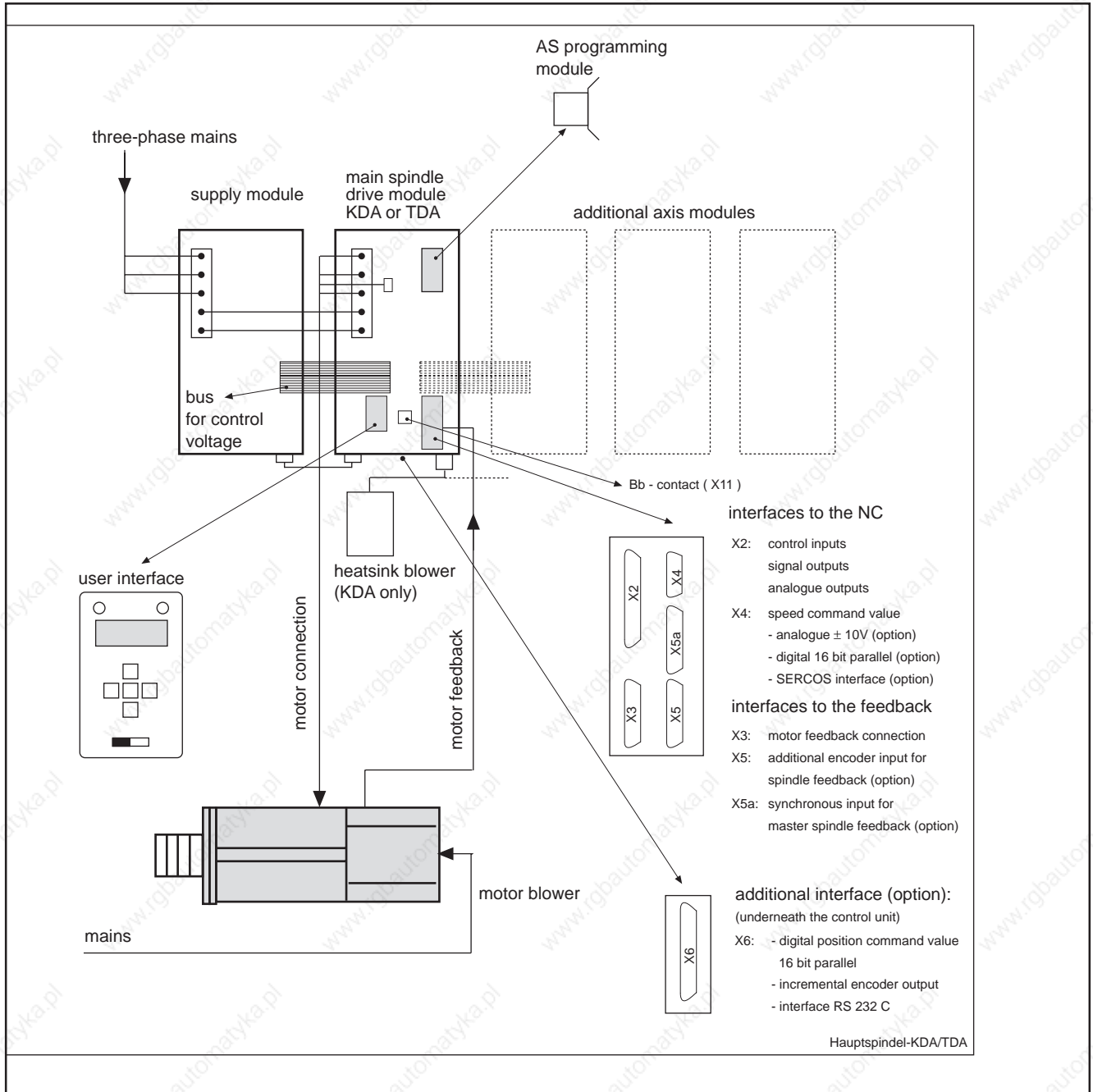

Figure 2: Main spindle drives with KDA or TDA (modular drive system)

# 1. Commissioning INDRAMAT AC Main Spindle Drives

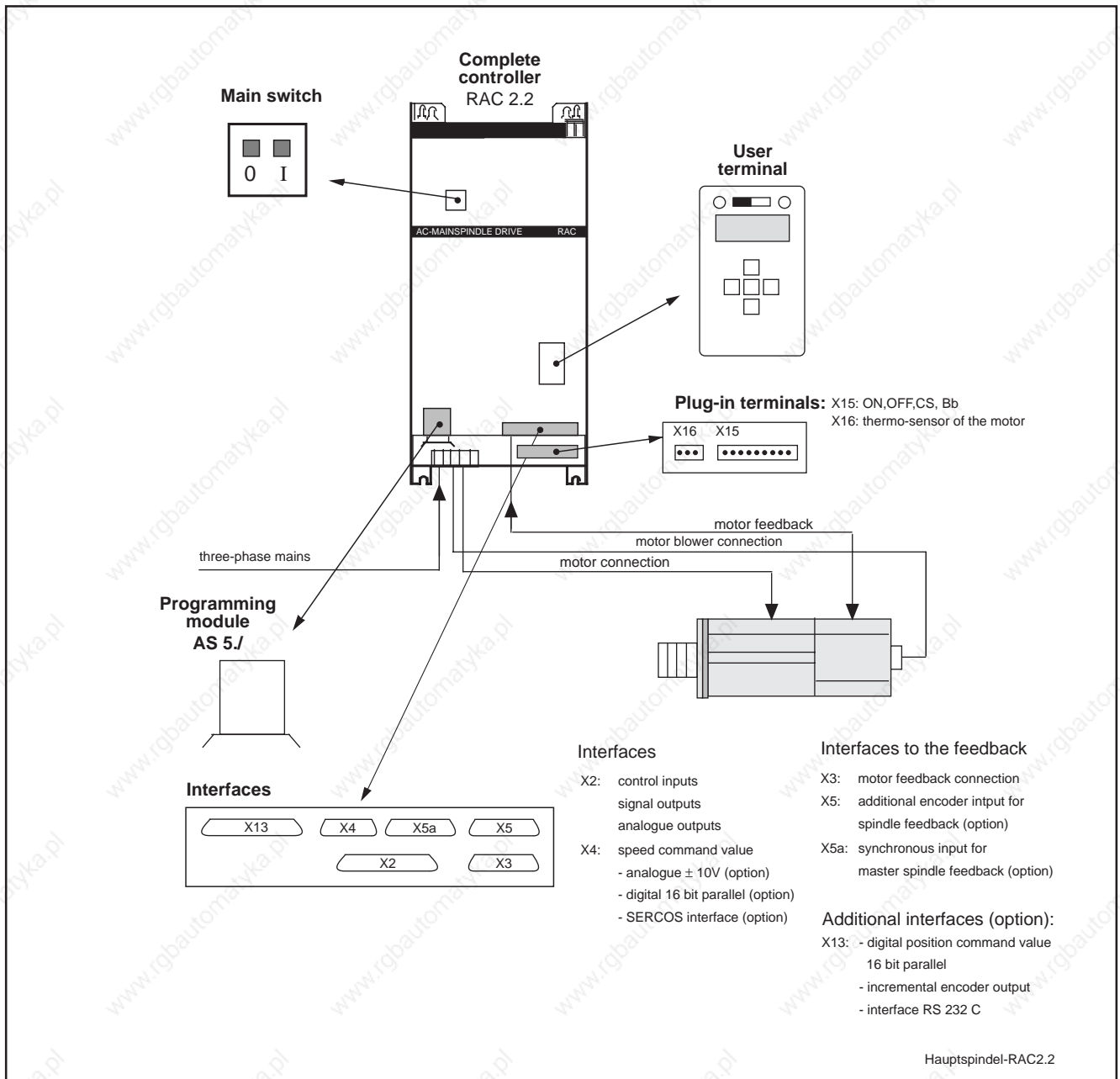

Figure 3: Main spindle drive with RAC 2.2 controller

# 1. Commissioning INDRAMAT AC Main Spindle Drives

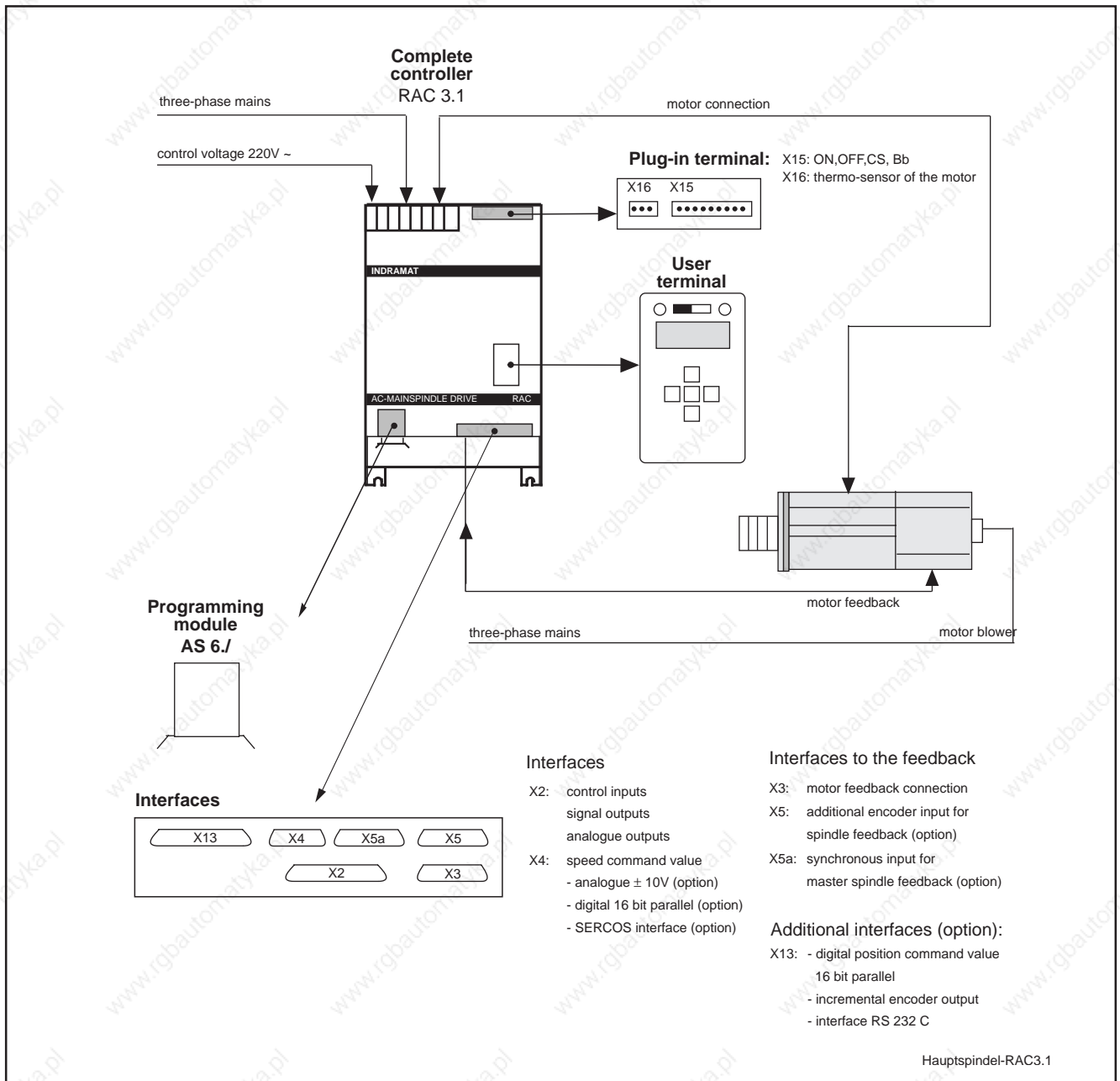

Figure 4: Main spindle drive with RAC 3.1 complete controller

For RAC 4.1:

The same arrangement applies here as with an RAC 2.2 (Figure 3). The motor blower does not receive its power from the RAC 4.1, however. It must be directly connected to the three-phase mains!

The name of the programming module is AS 8./..

## 1.2 Safety Guidelines

### 1.2.1 Notes on Protecting Personnel

The following problems can occur when operating a drive or a drive package for the first time:

- wiring fault
- fault in NC program
- for operational reasons, monitors are not working

These can cause increased risk of accidents and can lead to

- personal injuries,
- damage to drives and
- machines.

The drive may only be operated as prescribed in the relevant documentation!

#### *Danger from moving axes*

There is danger from moving axes due to

- unintentional starting due to malfunctions and faults and
- operation in the speed or position control circuit.

Precautionary measures for personnel:

- Personnel must not remain in the area of the machine in which movements can take place.
- The drives must be stopped and secured against unintentional starting when personnel are working in the hazardous area.

Precautionary measures against unintentional starting:

- Disconnect the power contactor (EMERGENCY STOP).
- Switch the master switch off during prolonged breaks in operation.

#### *Danger from contact with electrical parts*

Dangerous voltages on equipment terminals:

- mains voltage L1, L2 and L3
- DC bus voltage L+,L-
- motor voltage A1, A2 and A3



**Open master switches and secure against reconnection prior to working on electrical equipment. The drives must be securely locked because voltage appears on the motor cables when the motors rotate!**

### 1.2.2 Guidelines on Protecting Equipment

*Risk of damage due to incorrect connection*

- Allow approximately five minutes for DC bus to discharge. Check that voltage is below 50V before commencing work. If in doubt, use short-circuit!
- The transparent cover or front panel must be screwed on to prevent accidental contact during operation.
- Current-operated e.l.c.b systems cannot be used with INDRAMAT equipment. In the case of indirect contact, the mains contactor should be replaced by other means, e.g., overcurrent protective devices.

*Risk of damage due to separate source or high voltage*

Indramat electronic drive components are fitted with comprehensive protection circuits and are protected against overload as far as is technically feasible.

- Connect to the inputs of the unit only those voltages which conform to the specified data.
- Outputs must not be connected to separate voltage sources.
- Mains, DC bus and motor cables must not be connected to or brought into contact with low-voltage  $\pm 15V$  and  $+24V$  rails. They must be adequately insulated from each other.

Indramat drive components are subjected during routine testing to high-voltage tests which conform to VDE 0160 standards.

If a high-voltage or separate-source voltage withstand test is carried out on the electrical equipment of the machine, then all the connections of the unit must be disconnected or withdrawn to avoid damaging the electronic components in the units (permissible as per VDE 0113).

*Risk of damage due to electrostatic charge*

Electrostatic charges damage electronic components. The human body, which can come into contact with components and printed circuit boards, must be discharged by earthing:

- the human body by touching a conductive, earthed object
- the soldering iron when soldering
- parts and tools must be placed on a conductive substrate

Components at risk, such as programming modules, should only be stored or dispatched in conductive packaging.

### 1.2.3 Guidelines on Protecting the Machine

If, during commissioning, the position control loop of the NC controller is run and the drive is run in the speed control loop, then there exists the risk of damage to the machine because of the limited travel of linear axes.

To prevent machine damage:

- the drive enable signal and speed command value should only be applied by skilled personnel and
- the emergency stop facility should be provided by limit switches or EMERGENCY-STOP (E-stop) buttons.

### 1.3 The Equipment Required

The following equipment is needed for commissioning:

- DC and AC multimeter
- command value box (analogue command value)
- 37-pin subminiature connector
- 9-pin subminiature connector
- 10-pin plug terminal block (RAC only)

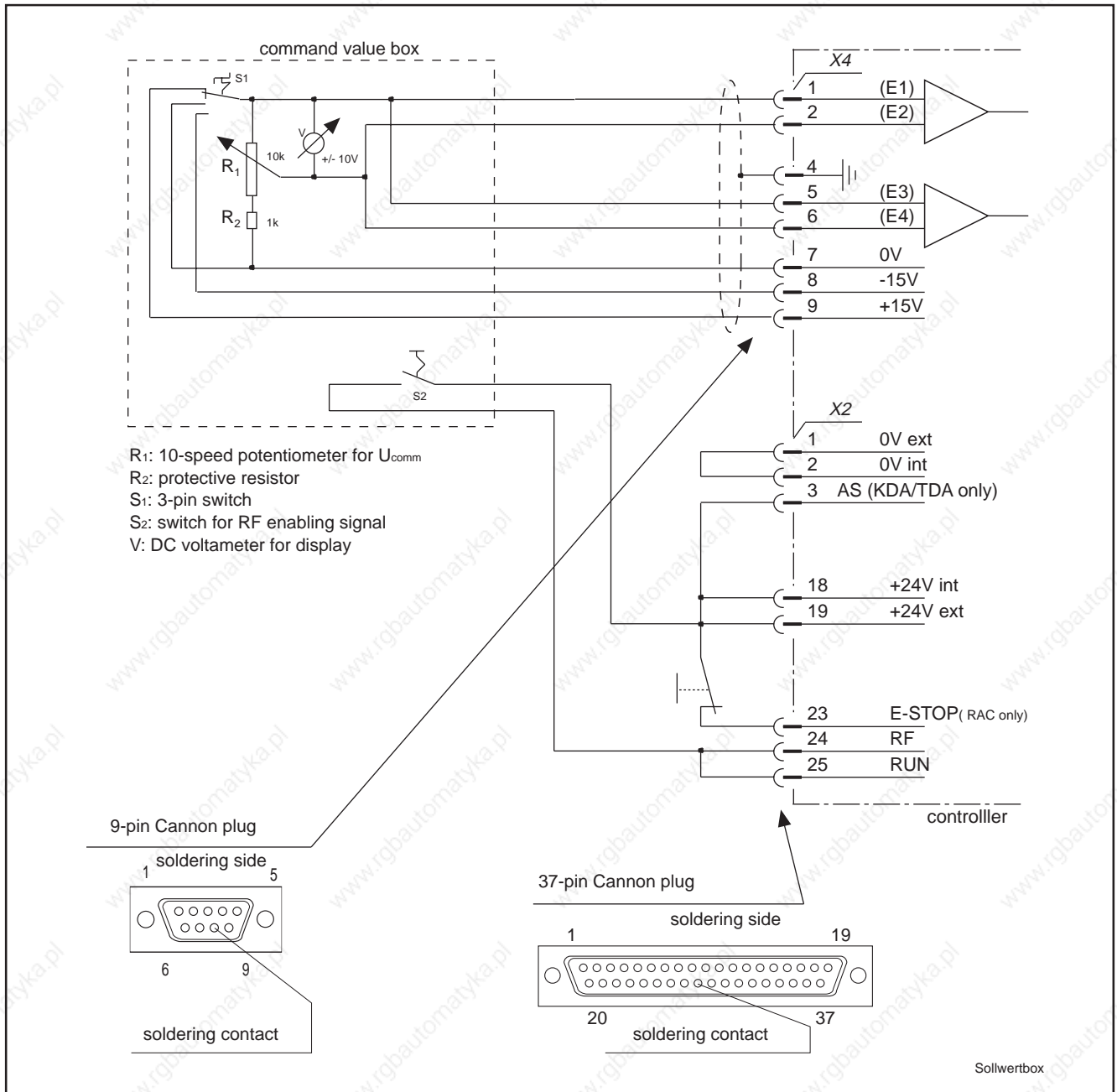

Figure 5: Circuit for operating the drive with the above equipment (command value box and subminiature connectors)

## 1.4 Main Spindle Drives with KDA or TDA

### 1.4.1 Mains Supply Requirements

Each time prior to switching on, check that the mains supply meets the requirements of the supply module being used (see supply module documentation).

### 1.4.2 Checks with the Equipment Switched Off

#### *Checking the drive components*

The installed drive components must be designed for the existing input voltages. The input voltages shown on the rating plate should be checked against the type code (see respective drive and supply module documentation).

The details on the AS programming module must match the ratings of the installed drive components, otherwise there is a risk of damage.

#### *Condition of wiring*

Check the wiring for short-circuits, breaks, incorrect connections, conductor cross sections and identify these against the Indramat connection diagram.

- **Earthing arrangements:**

The earthing arrangements should be made exactly as per the respective connection diagrams. These should also include the relevant protective measures for the machine. Each motor must be earthed at its associated drive module.

Drive modules should be separately earthed at the power supply module. The earthing point of the supply module is the central reference earth point for all drive components. This should be connected to the mains earth. The above earth connections provide an operational earth with a protective function.

When installing the modules in the control cabinet, ensure that the housing makes a good electrical connection with the control cabinet. Otherwise faults could occur.

- **Twisting the load conductors:**

The motor connections from the main drive module should be either twisted or a four-core cable (3 x phase, 1 x earth) should be used.

- **Connections to auxiliary modules:**

The power connections to the additional capacitance module or to further additional storage capacitors should be twisted and kept as short as possible.

- **Power connections to the main drive modules:**

Normally, the units are alongside each other and the connection is made via two busbars. If this is not possible, then the power connection must be made with two twisted 16 mm<sup>2</sup> conductors not more than one meter in length.

#### *Cross sections of power cables*

The cross sections of conductors must be such that the permissible current densities stipulated by the relevant specifications (VDE 0100 and VDE 0113) are not exceeded at the maximum ambient temperatures and the corresponding continuous motor and transformer currents.

<i>Checking the terminals and connectors</i>	Check that the conductors are securely attached to the terminals, otherwise there exists the risk of damage. The subminiature connectors must be screwed up!
<i>Bus connecting cable</i>	The control voltage and monitor connections are made via a bus cable the black core of which must be underneath.
<i>End connector for bus connecting cable</i>	Ensure that the line monitor end connector supplies with the power supply module is fitted to the drive module farthest from the power supply module.
<i>Shielding</i>	The shielding of the command value cable and motor feedback cable, the spindle transmitter cable and temperature sensor leads must be connected at the main drive module.
<i>Power transformer connection</i>	Where a power transformer is required for the supply module, make sure that the primary and secondary sides of the transformer are not interchanged. Excessively high supply voltage can damage the drive.

### 1.4.3 Checks with the Signal Conditioning Powered Up

First, with the drive package switched off, disconnect the speed command from the controller (X4) and remove the connections to the control inputs and signal outputs (X2). Connect the command value box to interface X4 and connect the control inputs X2 as shown in Figure 4 of section 1.3.

Control voltage must be available at the power supply module before the following checks can be carried out. The voltage for the signal conditioning circuits is then available in the drive modules. The mains contactor K1 must be switched off.

*Check LED and LCD display status signals*

<b>At the supply module:</b>	<b>Color:</b>	<b>Status:</b>
• bleeder overload	red	off
• power on	green	off

<b>At the main drive module KDA or TDA:</b>		
• FAULT	red	off
• READY	green	off
• NO POWER must appear in the LCD display.		

*Blower operation*

Check the blower and the electrical connections in the main drive modules and the main drive motors.

*Power stage on/off sequence*

The correct switching sequence is obtained when the "ready" contacts of the supply and main drive modules are installed as per the Indramat connection diagrams. The power can only then be applied when the Bb1 contact in the supply module is closed. Any series resistors are short-circuited only if the Bb contact of the main drive modules closes or +24V is present at the READY output.

*DC bus dynamic braking* To ensure that the main drive can be braked when the mains is disconnected, fit no DC bus short-circuit resistor.

*Checking motor feedback* Set mode switch to right. Pressing the "up" arrow key brings the motor speed N into the display (see Section 2, "Operating the Controllers"). Positive speed must be indicated on the display when the motor shaft is rotated clockwise by hand (motor shaft viewed from front).

*Checking the speed command value (analogue)* Press the "up" arrow until speed command C appears.

- Positive voltage at connector X4/1 with respect to X4/2 shows a positive command in the display.
- For C-axis operation, apply positive command to connector X4/5 with respect to X4/6. Activate command value input via EXT POS input and parameter PQ-FUNCT (P/Q/R/S 16). A positive command again appears in the display (see Section 3.8, "C-axis Operation").



**The null of the command value input is set at the factory with the inputs short-circuited and may be adjusted for command value input X4/1 and X4/2 with potentiometer P1 above connector X4, and command value input X4/5 and X4/6 with potentiometer P2 below X4.**

*Checking the spindle speed detector* Condition: separate spindle feedback must be connected to the optional interface on the second encoder input (X5). Press the "up" arrow key until spindle speed S appears in the display. Positive speed must appear in the display when the incremental encoder shaft is rotated clockwise by hand.

*Checking the motor temperature detector* Press the "up" arrow key until motor temperature T appears.

- Display with cold motor: „T<40°C“.
- A flashing display means that the motor temperature sensors are incorrectly connected or the motor temperature is less than 0°C.
- The drive switches off after ten minutes if the motor temperature sensors are faulty. „NO TEMP“ appears. „TEMP WARN“ goes to 0 thirty seconds before this.

#### 1.4.4 Checks after the Power Infeed has been Connected

*Check status signals* Set controller enabling switch on command value box to OFF and set speed command value to 0 volts.

Now, connect the power supply to the drive package.

- The green "power on" LED on the supply module must light up.
- "NO RF" (no controller enabling signal) must appear in the KDA module display.
- The green LED „READY“ on the KDA must light up.

*DC bus voltage* Press the "up" arrow key until the DC bus voltage (UD) appears. A voltage of between 255 and 345 V must be indicated.

### 1.4.5 Initial Start-Up

*Operating the drive with the command value box*

Switch on the controller enabling signal on the command value box. Apply a small command value. The speed of the drive must follow the command value input.



**In the event of a fault, the drive can "chatter" uncontrollably. Disconnect the controller enabling signal immediately. If the motor rotates in an uncoordinated way, check that the phasing of the motor power connections is correct. If the motor rotates at low speeds only, without following the command value, then check the feedback connections!**

*Checking the speed/ command value ratio*

The drive must reach the speed specified in parameter MAX RPM (A01) when the command value voltage programmed in parameter CMD VOLT (A02) is applied.

## 1.5 Main Spindle Drives with RAC Controllers

### 1.5.1 Mains Requirements

*For RAC 2.2 and RAC 4.1* Before switching on each time, check that the following mains requirements are met:

- For 380V type: (type code field „AC supply voltage“=380)  
3 x 400V +6% -15% 50 to 60 Hz
- For 460V type: (type code field „AC supply voltage“ = 460)  
3 x 400V  $\pm$ 15%, 50 Hz or 3 x 460V  $\pm$ 10%, 60 Hz
- mains-related earth

*For RAC 3.1* 3 x 380V...460V  $\pm$ 10% 50 to 60 Hz

- mains-related earth

A transformer is not needed if the mains supply meets these conditions.

*Other mains supplies* In the case of three-phase supplies with mains-related earth, conductor but with phase-phase voltages other than those stated above, an autotransformer must be used for voltage matching.

With three-phase supplies without mains-related conductor but with phase-phase voltages meeting the above requirements, no isolating transformer is necessary if the mains meets special conditions and the RAC is protected by overvoltage protection devices (see "Electrical Connections").

With three-phase supplies without mains-related earth conductor and different mains voltages, a three-phase isolating transformer, with a secondary voltage as stated above and a short-circuit voltage not exceeding 4%, must be used. The neutral point of the secondary must be connected to the system earth (see "Electrical Connections").

### 1.5.2 Checks with the Equipment Switched-Off

*Checking the installed drive components* Compare the data on the equipment rating plates with the existing supply voltage.

The details on the AS programming module must match the ratings of the installed drive components, otherwise there is the risk of damage.

If a KDA 34.2 is to be operated with an RAC 2.2, then the KDA must be designed for a supply voltage of 500 V (type code field "DC supply voltage" = 500).

*Condition of wiring* Check the wiring for short-circuits, breaks, incorrect connections, conductor cross sections and compare with the Indramat connection diagram.

- Earthing arrangements:  
The earthing arrangements should be made as per the respective Indramat connection diagrams. These should also include the relevant protective measures for the machine. The earth connection provides an operational earth with a protective function.

When installing the RAC into the control cabinet, ensure that the housing makes a good electrical connection with the cabinet. Faults could otherwise occur.

- Twisting the load conductors:  
The motor connections from the RAC should either be twisted or a four-core cable (3 x phase, 1 x earth) should be used.
- Connections to other KDA modules (RAC 2.2 only):  
The power connections to additional KDA main drive modules should be twisted and kept as short as possible.

### *Cross sections of power cables*

The cross sections of conductors must be such that the permissible current densities stipulated by the relevant specifications (VDE 0100 and VDE 0113) are not exceeded at the maximum ambient temperatures and the corresponding continuous motor and transformer currents.

### *Checking the terminals and the connectors*

Check that the conductors are securely attached to the terminals, otherwise there is the risk of damage. The subminiature connector must be screwed up!

### *Bus connecting cable to additional KDA drive module (RAC 2.2 only)*

The control voltage and monitor connections are made via a bus cable the black core of which is underneath. An end connector is not required.

### *Shielding*

The shields of the command cable and motor feedback cable, the spindle transmitter cable and temperature sensor leads must be connected at the RAC.

### *Power transformer connections*

Where a power transformer is required, ensure that the primary and secondary sides of the transformer are not interchanged. Excessively high supply voltage can damage the drive package!

## **1.5.3 Checks with Mains Supply Connected/Power Circuits Disconnected**

### *Control voltage ON*

First, with the RAC switched off, disconnect the speed command from the controller (X4) and remove the connections to the control inputs and signal outputs (X2). Connect the command value box to interface X4 and connect up the control inputs X2 as shown in Figure 14 of section 1.3.

RAC 2.2: set master switch to ON

RAC 3.1: apply 220 V control voltage to terminal X14

Check the following messages on the control panel:

- both the READY and FAULT LEDs remain off
- NO POWER appears in the display

### *Blower operation*

Check operation of blower on the controller and the main drive motor.

A transformer is only required for the motor blower supply if the RAC 3.1 or RAC 4.1 is connected to three-phase mains supplies with rated voltages exceeding 3 x 420 V, 50 Hz. There are terminals for the motor blower on the RAC 2.2.

The motor blower is protected internally when mounted in the RAC 2.2 by means of the Q1 circuit breaker.

The Q1 circuit breaker must be set as follows for axial blowers on 2AD motors:

RAC 2.2 with 2AD 132/2AD 160 – 0.63 A  
RAC 2.2 with 2AD 180 – 1.00 A

The value actually set depends on the respective supply module of the RAC 2.2. Blowers of separate motors must be directly connected to three-phase mains via a separate circuit breaker!

*Checking the motor feedback*

Pressing the "up" arrow key brings the motor speed N into the display. Positive speed must be indicated on the display when the motor shaft is rotated clockwise by hand (motor shaft viewed from front).

*Checking the speed command value*

Press the "up" arrow until speed command value C appears.

- Positive voltage at connector X4/1 with respect to X4/2 shows a positive command value in the display.
- For C-axis operation, apply positive command to connector X4/5 with respect to X4/6. Activate command value input via EXT POS input and parameter PQ-FUNCT (PQRS 16). A positive command value again appears in the display (see section 3.8, "C-axis Operation").



**The null of the command value input is set at the factory with the inputs short-circuited and may be adjusted for command value input X4/1 and X4/2 with potentiometer P1 to the left of connector X4, and command value input X4/5 and X4/6 with potentiometer P2 to the right of X4.**

*Checking the spindle speed detector*

Condition: separate spindle feedback must be connected to the optional interface for the second encoder input (X5).

Press the "up" arrow key until spindle speed S appears on the display.

A positive speed must appear in the display when the incremental encoder shaft is rotated clockwise by hand.

*Checking motor temperature measurement*

Press the "up" arrow key until motor temperature T appears.

- Indication with cold motor: „T<40°C“
- A flashing display means that the motor temperature sensors are incorrectly connected or the motor temperature is less than 0°C.
- The drive switches off after ten minutes if the motor temperature sensors are faulty. „NO TEMP“ appears. „TEMP WARN“ goes to zero 30 seconds before this.

### 1.5.4 Connecting the Power Infeed

Set controller enabling switch on command value box to OFF and set speed command value to 0 volts.

The power is applied by shunting the ON and OFF contacts on terminals strip X15. Do this by using a ten-pin terminal block with two switches, i.e., a N/O contact between terminals 1 and 2, and an N/C between 3 and 4. Attach the terminal to X15.



**The power must not be disconnected with the N/C contact when the motor is rotating as the motor could coast uncontrollably. Switch the control input E-stop (X2/23) to 0. Fit N/C contact between X2/18 and X2/23 (see Figure 4, section 1.3). The motor is then braked to a standstill before the main contactor is disengaged!**

*Controlling the messages*

Check the messages on the control panel:

- the green READY LED must come on and
- the message NO RF (no controller enabling signal) appears on the display.

*Checking the DC bus voltage*

Press the "up" arrow key until the DC bus voltage (UD) appears. A voltage of between 480 and 550 V must be indicated.

### 1.5.5 Initial Start-Up

*Operating the drive with the command value box*

Switch on controller enabling signal on command value box. Apply a small command value. The speed of the drive must follow the command value input.



**With a fault, the drive can "chatter" uncontrollably. Disconnect the controller enabling signal immediately. If the motor rotates in an uncoordinated way, check that the phasing of the motor power connections is correct. If the motor rotates at low speed only without following the command value, check the feedback connections.**

*Checking the speed / command value ratio*

The drive must reach the speed specified in parameter MAX RPM (A01) when the command value voltage programmed in parameter CMD VOLT (A02) is applied.

## 2. Operating the Controllers

Indramat main spindle drives make a wide range of functions available for numerous applications. The drives can be easily matched to specified applications.

The controllers are operated via the control panel, provided that the controllers are supplied with control voltage, i.e., commissioning must have already been carried out to a large extent.

### 2.1 The Control Panel

The control panel is located on the front panel of the controller. It is used for drive and fault diagnoses, checking and setting parameters. The green LED indicates the drive is OK, the red LED comes on with a fault.

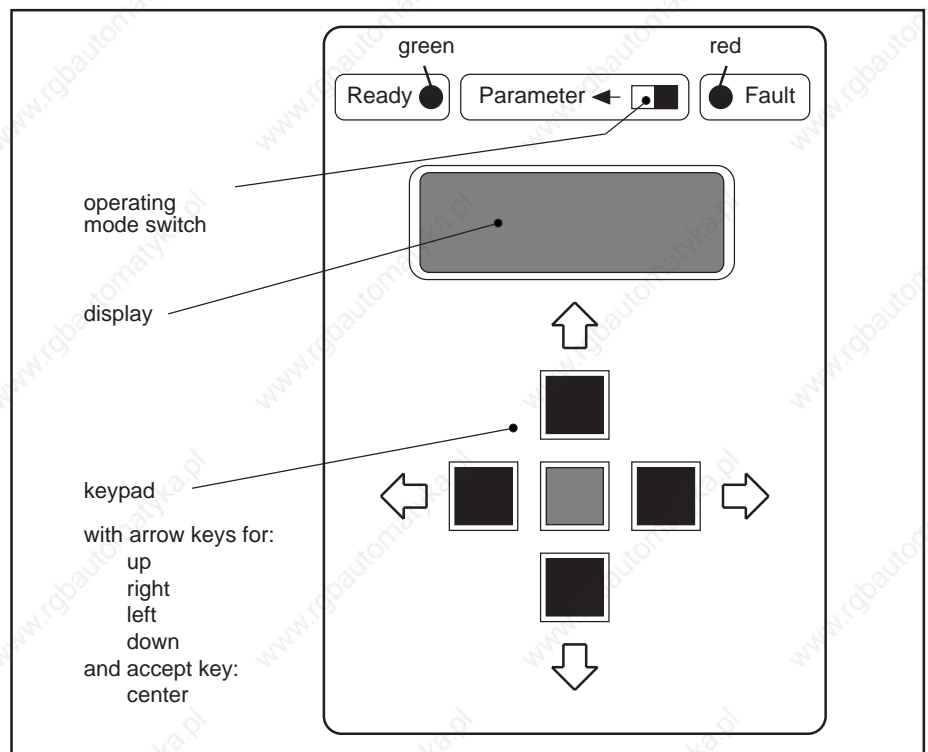

Figure 6: Control panel with legends

**Operating mode** The mode switches enable the main spindle drive to be changed from the operating mode to the parameter mode.

The main spindle drive is ready for power input or power output. The mode switch is set to the right.

**Parameter mode** Power output from the main spindle drive is inhibited. Parameters can be checked and changed. The mode switch is set to the left.

## 2.2 Main Spindle Drive in Operating Mode

The main spindle drive is ready for power input or output.

### Choice of operating mode:

The mode selection switch must be set to the right. Control voltage must be present.

### Message in Display at Power Up:

If the unit is only supplied with control voltage, NO POWER is displayed. Both LEDs are off. If the unit is ready for power output, NO RF is displayed. The green LED comes on.

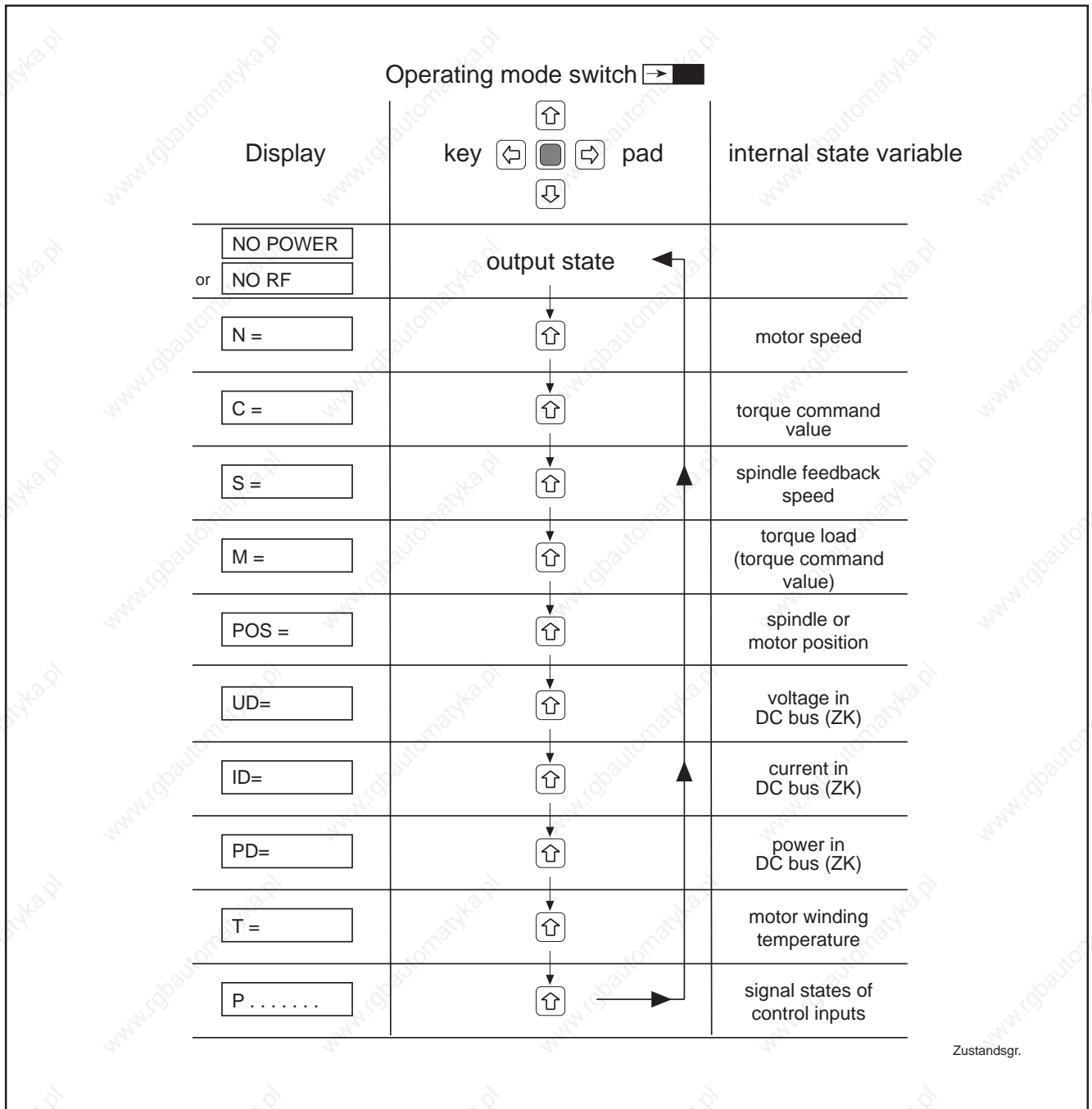

Figure 7: Internal state variables of the drive

### 2.2.1 Displaying the Internal State Variables of the Drive

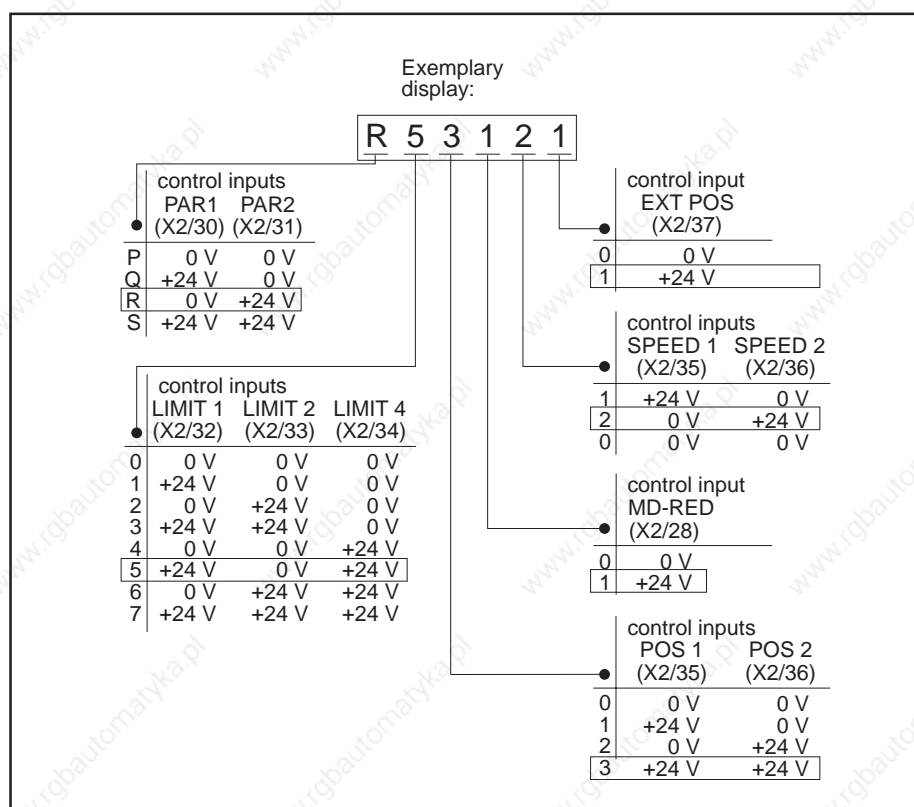

Figure 8: Display of signal states of control inputs and assignment of digits

In operating mode, all the internal state variables of the drive that are important for drive diagnostics can be called up into the display. This is done by pressing the "up" and "down" arrow keys. The "down" key enables the sequence shown in Figure 6 to be displayed in reverse order. Both keys have a continuous function.

**Note:** Pressing the red central key (accept key) moves the display back from the current position to the initial state. The signal states of the control inputs are also displayed.

### 2.2.2 Outputting the Drive Internal State Variables for Analogue Output N

























Analogue output N (X23/21) is designed as a universal output. It outputs voltage between -10 and +10 volts. The internal state variables of the drive which are displayed can be switched to the analogue output N as a voltage by pressing the LEFT arrow key. This is possible when the control voltage is applied and allows the variations in the state variables to be recorded with just one measuring set-up, e.g., via an oscilloscope, when the drive is operating.

#### Note on Figure 8

All the state variables of the drive can be called up into the display when the assignment of the analogue output N is unchanged. The contents of the previous display can be restored or scrolled backwards by pressing the DOWN key.

Pressing the red ACCEPT key resets the display to the initial state. The assignment of analogue N output remains unchanged.

## 2. Operating the Controllers

Display	key    pad 	Analogue output N (X2/21)	
		Definition	Weighting
NO POWER NO RF			
N=NCMD			
N	Output status	Motor speed	$\pm 10 \text{ V} \hat{=} \pm \text{MAX RPM}$
		Motor speed, high-resolution	$\pm 10 \text{ V} \hat{=} \pm 50 \text{ 1/min}$ over the entire speed range
		Motor speed	$\pm 10 \text{ V} \hat{=} \text{MAX RPM}$ (value in parameter A01)
C		The last selected weighting of the N output is maintained.	
		Speed command value	$\pm 10 \text{ V} \hat{=} \text{MAX RPM}$ (value in parameter A01)
		Internal speed command value (after ramp)	$\pm 10 \text{ V} \hat{=} \text{MAX RPM}$ (value in parameter A01)
S		The last selected weighting of the N output is maintained.	
		Spindle encoder speed	$\pm 10 \text{ V} \hat{=} \pm 10\,000 \text{ 1/min}$
M		The last selected weighting of the N output is maintained.	
		Torque command value, no delay	$\pm 10 \text{ V} \hat{=} \text{drive-dependent torque command value}$
POS		The last selected weighting of the N output is maintained.	
		Spindle position (motor position) in $\angle$ degrees	$\pm 10 \text{ V} \hat{=} \pm 180^\circ$
		Spindle position (motor position) in $\angle$ deg. (high-resolution)	$-10 \text{ V} \dots +10 \text{ V} \hat{=} 0.044^\circ$
UD		The last selected weighting of the N output is maintained.	
		voltage in DC bus (ZK)	$+10 \text{ V} \hat{=} +1000 \text{ V}$ in the DC bus (ZK)
ID		The last selected weighting of the N output is maintained.	
		current in DC bus (ZK)	$\pm 10 \text{ V} \hat{=} \text{rated current of the control unit}$
PD		The last selected weighting of the N output is maintained.	
		power in DC bus (ZK)	$\pm 10 \text{ V} \hat{=} \pm 100 \text{ kW}$ with RAC 2.2 $\pm 50 \text{ kW}$ with KDA 3 and RAC 3
T		The last selected weighting of the N output is maintained.	
		motor winding temperature	$0 \dots +10 \text{ V} \hat{=} 0 \dots +150^\circ \text{ C}$
P.....		The last selected weighting of the N output is maintained.	

Analoq N

Figure 9: Switching the analogue output N of the internal state variables of the drive

### 2.3 The Main Spindle Drive in Parameter Mode

Switching into parameter mode

The main spindle drive is not ready for either power input or output. The parameters can be tested, read and changed. They are stored in an EEPROM on the AS programming module.

The mode selection switch must be set to the left. Control voltage must be present.



**If parameter mode is selected when the motor is rotating, the drive brakes to a standstill and remains without torque!**

Message in display:

(P01...) appears when the parameter mode is selected for the first time after the control voltage is applied. Otherwise, the parameter displayed is the one which was current when the operating mode was reselected.

#### 2.3.1 Parameter Value Quick-Check

The parameter values of a programming module are stored with a parameter checksum. This is an advantage in that the many parameter values can be characterized by a number.

The correspondence between the current parameter values of the main spindle drive of a machine and the values in the parameter record in the machine file can be checked by comparing the checksums.

In standard production machines, the parameter checksum provides a rapid check indicating that the programming modules in use contain the correct parameter values.

The parameter checksum does not contain the value of the OFFSET parameter (A07) since this can differ, even in identical machines.

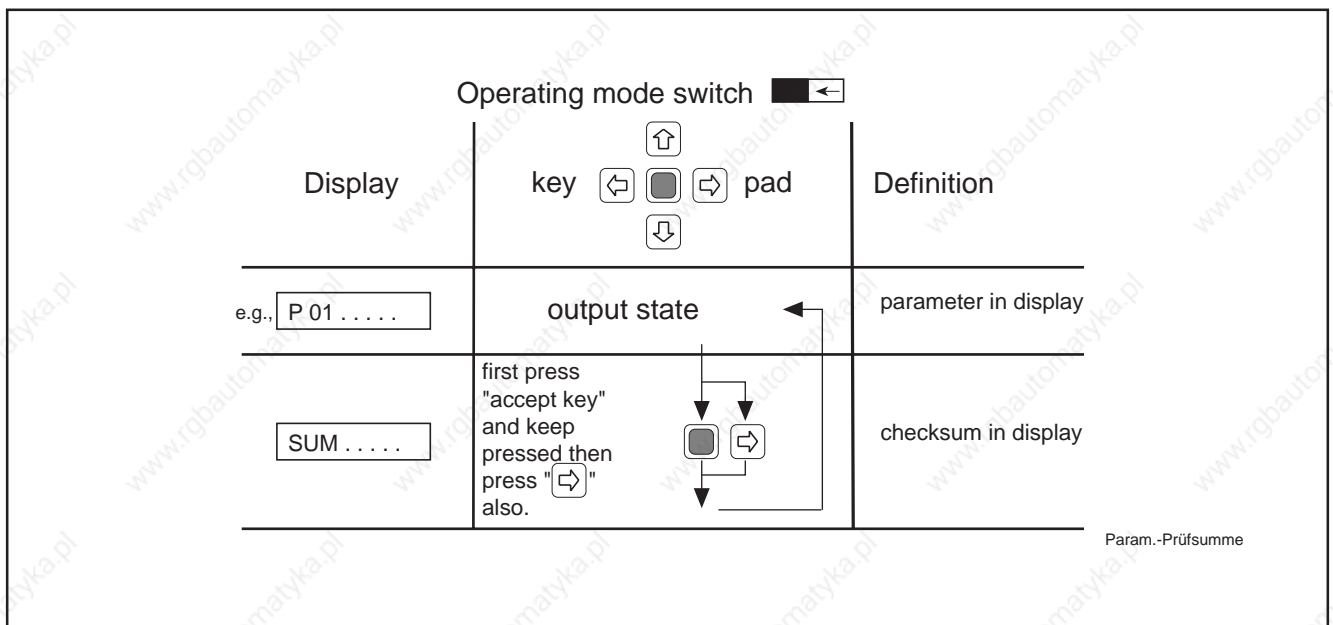

Figure 10: Parameter checksum display

### 2.3.2 Reading the Parameters

The parameter values can be called up into the display in the parameter mode. They are subdivided into six parameter records:

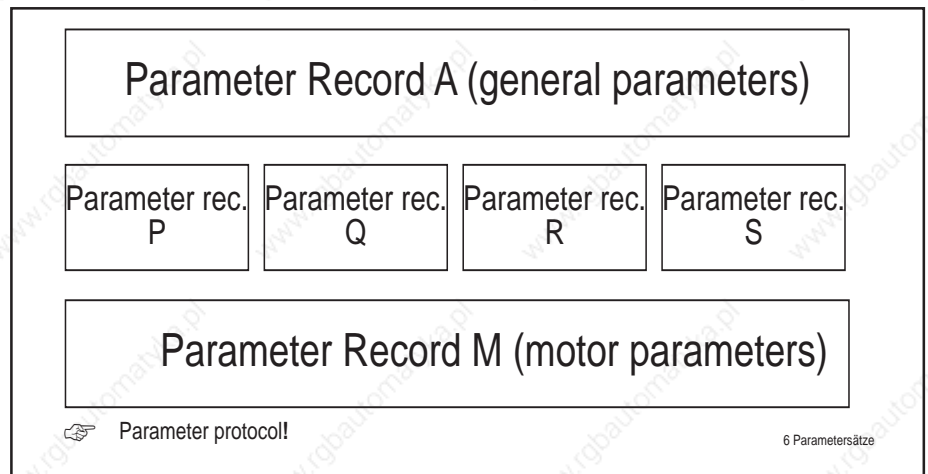

Figure 11: The six parameter records of Indramat main spindle drives

Parameter records A and M are permanently active, so is one of the four selectable parameter records P, Q, R or S.

#### Reading a parameter record

The parameter number, value and name can be displayed via the keyboard.

#### Changing to another parameter record

The other parameter records have to be displayed in order to read all the parameters. After changing to one of the other parameter records, the system for reading the parameter records as described is repeated.

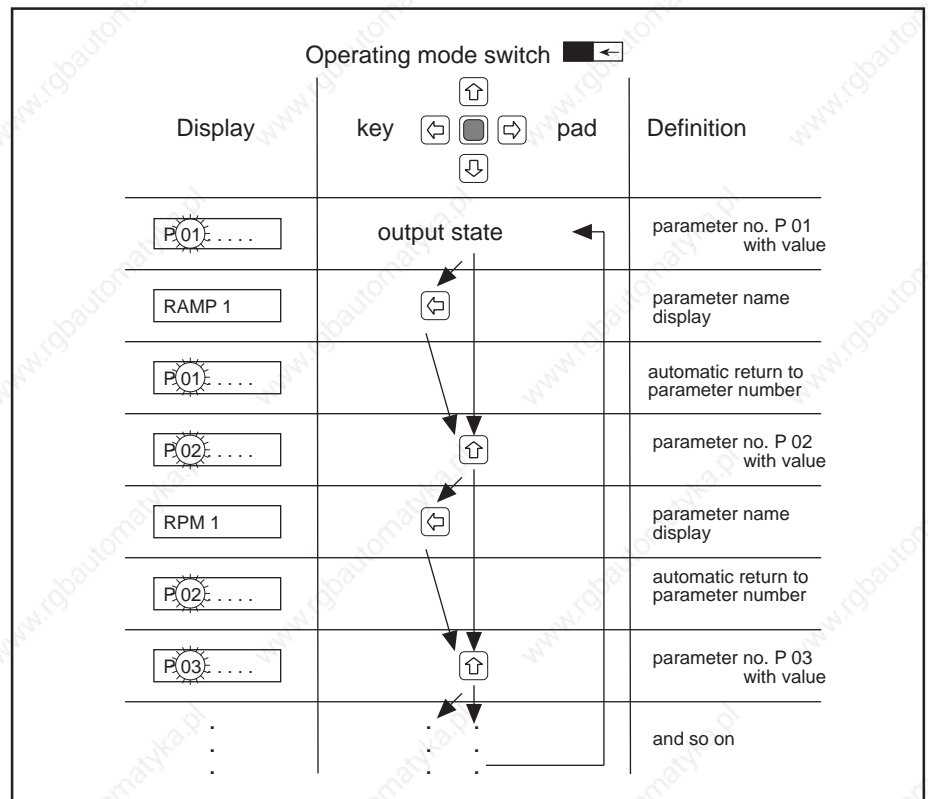

Figure 12: Reading a parameter record, e.g., parameter record P

*Recording the parameter values*

A parameter form for listing parameters is in section 5. This allows the values as supplied, and those modified by the user, to be recorded.

The permissible ranges of parameter values are also shown in the form.

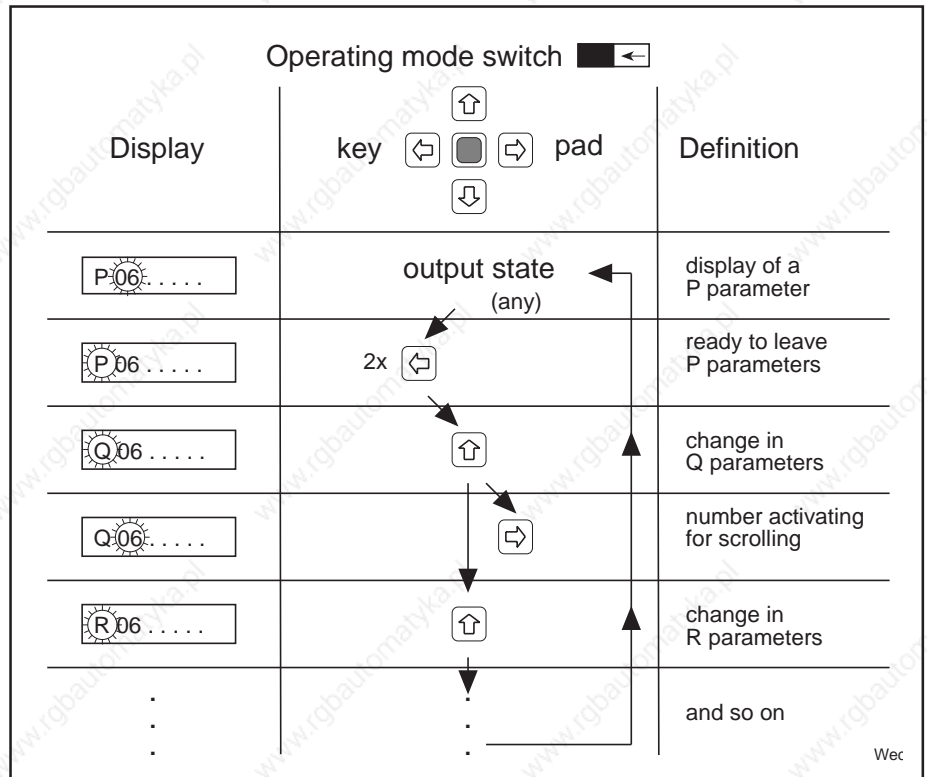

Figure 13: Changing the displayed parameter records

**2.3.3 Changing the Parameters**

The user parameters (A, P, Q, R and S) are given default values at the factory. Parameter values may need to be changed to match the drive to a special application.

The drive-specific motor parameters (m) have been optimized at the factory. They may only be modified by trained personnel, as otherwise the drive can be damaged. Exceptions are the M03 T-filter and M15 MOTFUNCT parameters (see section 5, parameter overview or list).

The parameter values are protected against unintentional modification by a code.

When a parameter gets a new value it must be transferred into the memory of the programming module by pressing the red key ("accept key").

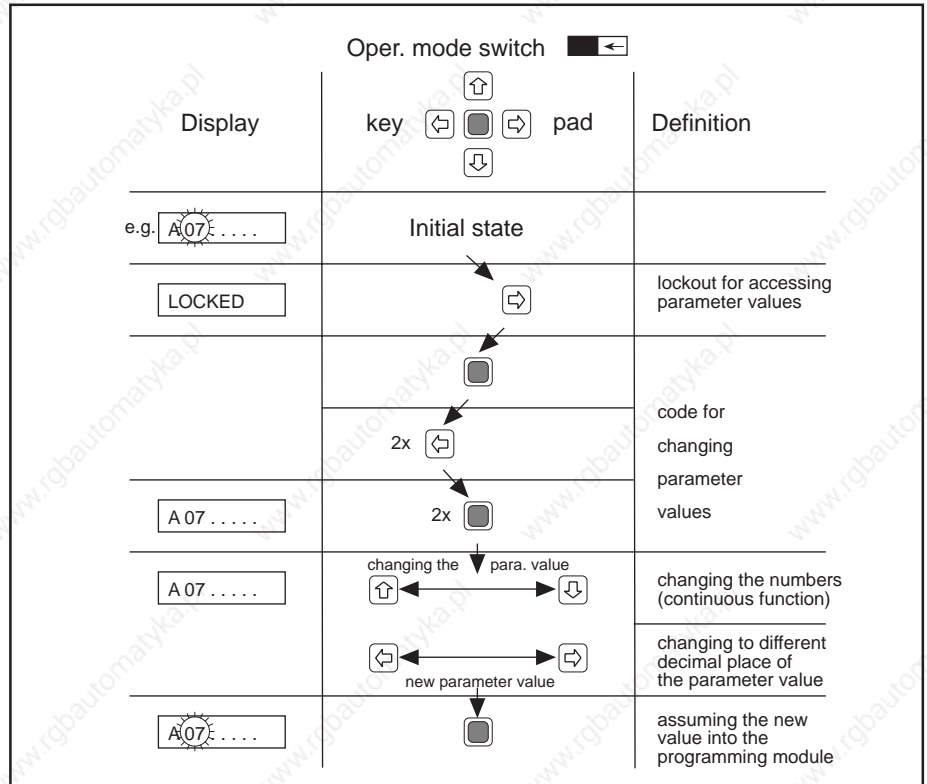

Figure 14: Changing the values in parameter records A, P, Q, R and S

**Note:**

The controller accepts the new value into memory if the LEFT key is pressed after the parameter value has been changed. The parameter number flashes and the old value is displayed.

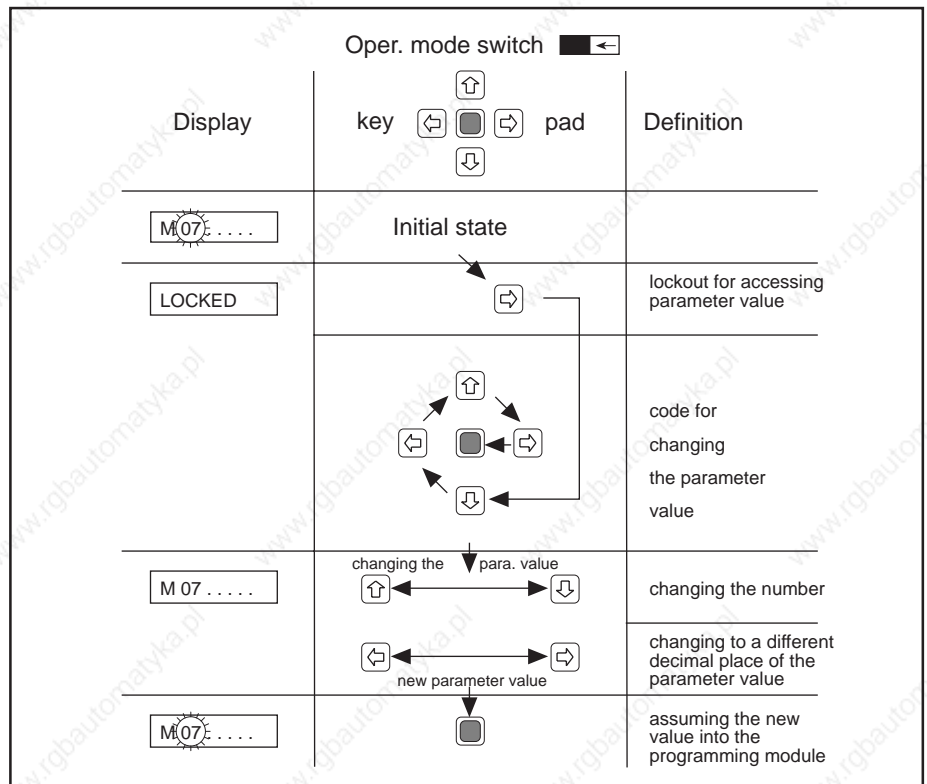

Figure 15: Changing the parameters in parameter record M



**There is a risk of damage from modified motor parameter values. To start up the drive again with the new parameters, the mode switch must be moved to the right. The message "RF-AGAIN" appears in the display. The RF control input must be switched from 0 to + 24 volts.**

*Possible fault messages*

Possible fault message: UNACCEPT  
 Cause: Invalid parameter combination  
 Remedy: Move operating mode switch to left and press the red key. The incorrect parameter is displayed. Enter a valid value.

Possible fault message: FEEDBACK  
 Cause: Type of motor feedback and value in M02 do not coincide.  
 Remedy: Move mode switch to left. Enter correct value (see 5.3).

### 2.3.4 Displaying the Software Version

Apart from the drive parameters, the AS programming module also holds the operating software. The name of the installed software can be

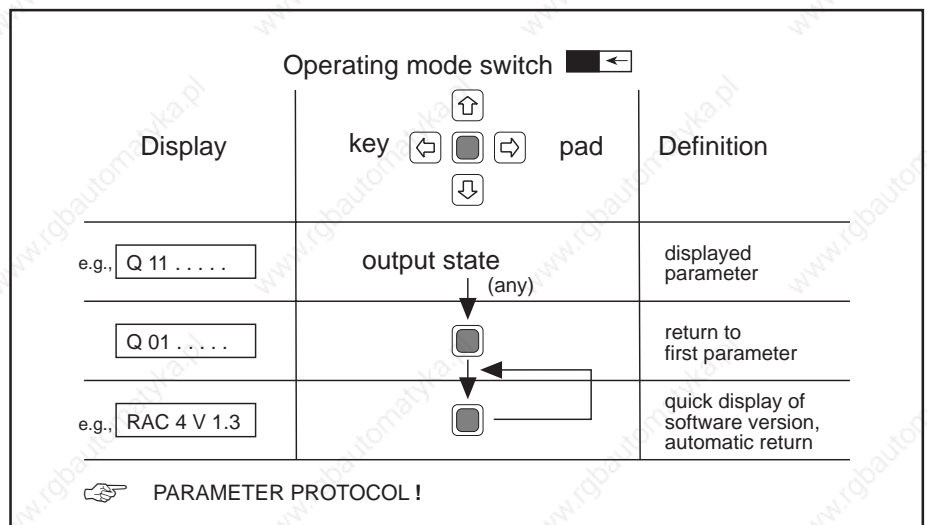

Figure 16: Software version display

called up on the display. The software version should be noted on the parameter form. It can be important when dealing with questions about applications.

### 2.3.5 Duplicating the Parameters

The parameter values of a programming module (master) can be copied to another (slave) for the same controller. This produces another programming module with the same parameter contents.

This enables

- parameter values to be protected (back-up copy) and
- programming modules to be rapidly provided with the necessary parameters for mass-produced machines.

Prerequisite:

Parameter duplication adapter PDA 1

### Procedure:

- Switch off main drive. Control voltage must not be present.
- Unplug programming module AS and replace with PDA 1.
- Plug the master programming module into the „MASTER“ connector.
- Plug the slave programming module into the „SLAVE“ connector.
- Move the operating mode switch to the left.
- Switch on the control voltage. The display now shows the checksum of the master module and a rotating pointer, i.e., transfer running (up to 30 seconds). If the mode switch is not set to the left-hand position, the prompt "SWITCH" appears and the transfer commences when the switch is moved to the left. At the end of the transfer, the display reads "SWITCH->".
- The mode switch must now be set to the right so that the contents of the slave EEPROM cannot be destroyed during any subsequent power down. If the switch is in the right-hand position, the checksum of the slave EEPROM appears along with the request to switch off the control voltage, e.g., "4B13 OFF".
- Switch off the control voltage and remove the slave module.
- If no further duplicates are to be made, replace the PDA 1 with the master programming module.



**Do not remove the programming module when power is on. The slave module is erased if no master module is plugged in.**



**During duplication, only the contents of the master EEPROM are transferred to the slave EEPROM. The system software is ignored. The checksums of the master and slave EEPROMs are not compared.**

### Possible fault messages

Possible fault message: EEPROM

Cause: EEPROM of slave module cannot be programmed.

Remedy: Switch the unit off and use a new slave module.

Possible fault message: PARALOST

Cause: Programming module has no parameters. Values are not loaded or parameters in software of master and slave modules do not agree.

Remedy: Move mode switch to left and press the red key. This loads the general parameters with which the drive can be put into service. If the message "BASISPART" appears in the display, the loading cycle is complete. Pressing the red key once again puts the drive into the parameter mode. The basic parameters are not optimized for the drive and they should be replaced by optimized values (AS/..).

### 2.3.6 Loading Operating Parameters via Serial Interface

Prerequisite: Serial interface on controller. (Type code field "additional interfaces": S), device for data input such as PC, magnetic tape, perforated tape or other control unit.

Purpose: Rapid input of parameters for mass production machines. Parameters can be printed out. For details on data transfer process see section 3.22, "Serial Interface".

## 3. Controller Functions

### 3.1 Drive "Ready" State

The main spindle drive is "ready" when the following conditions are met:

- All controller signal voltages must be present.
- The control inputs and signal outputs (terminal strip X2) must be supplied with  $\pm 24\text{ V}$  and  $0\text{ V}$ . The supply voltage should be provided via the external controller, but the internal  $+24\text{V}$  can also be used.
- The motor and controller temperatures are within permissible range:  
motor winding  $0 < J < 155^\circ\text{ C}$   
controller heatsink  $0 < J < J_{\text{maxperm}}$
- The mode switch must be to the right.
- There must be no fault message in the display.
- The DC bus voltage must be present.
- For an RAC the „E-Stop“ control input must be at 1.
- For KDA3/TDA 1 the "AS" (starting lockout) control input must be at 1.

The "ready" state of the drive can be evaluated via the "READY" signal output and the "Bb" potential-free contact.

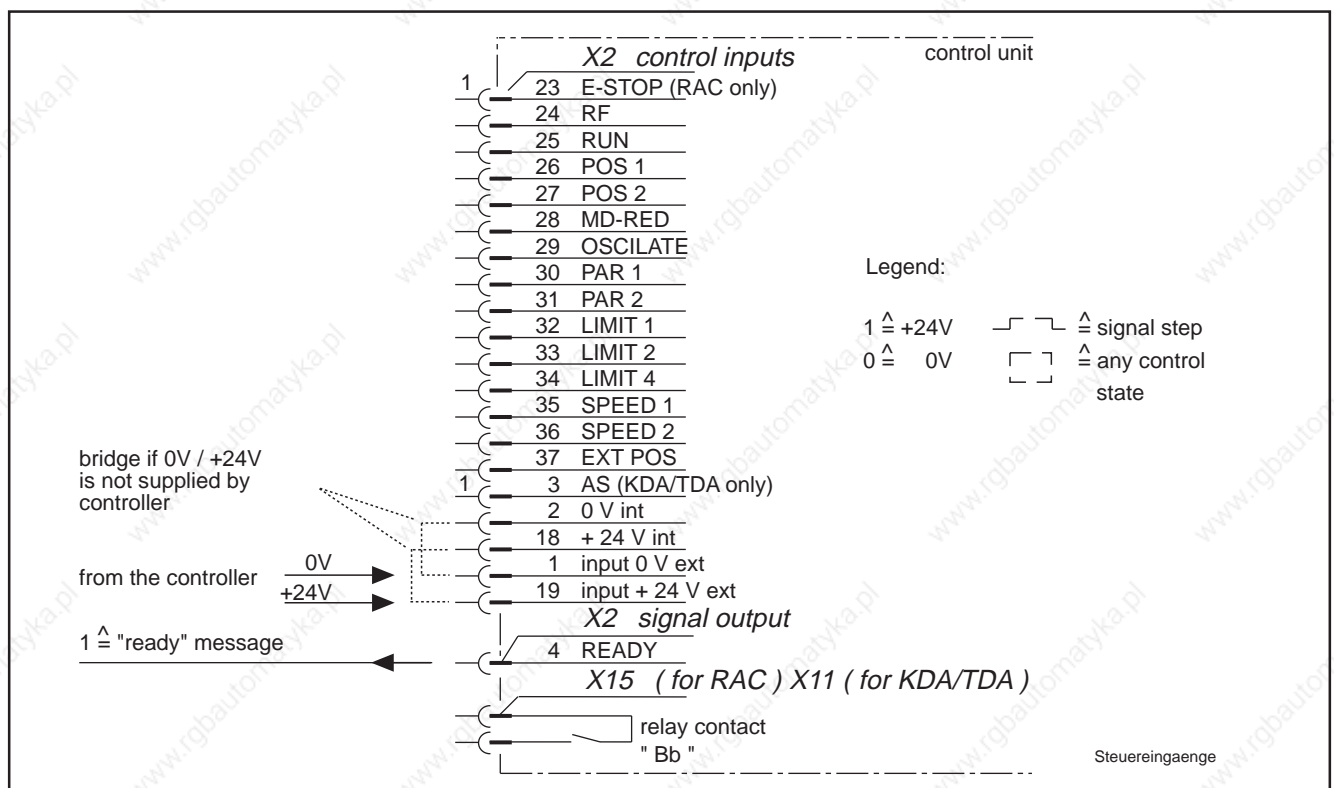

Figure 17: Control inputs and signal output, „Bb“ potential-free contact

#### "Ready" display

If the drive is "ready", it can start operating with the available functions. The green "READY" LED comes on. If there is a fault in the drive, the green "READY" LED is off, the red "FAULT" LED comes on and the fault message flashes in the display.

## 3.2 Speed Command Value

*Performance features* The speed command value can be communicated to the control devices from the controller via an analogue voltage or digitally via a bit pattern.

**Feature:** very broad speed range from minimum speed of 0.0005 rpm to maximum speed.

In addition, Indramat main spindle drives offer a far more powerful type of command value input via the "SERCOS interface" option (see section 3.2.1).

The speed command value is read at 1.2 ms intervals.

### 3.2.1 Analogue Speed Command Value (option)

The drive with interface for analogue speed command value is designed for multiple applications:

- as a main spindle drive
- as a positioning drive with various gear ratios
- as a C-axis drive for lathes

The differential input provides a large degree of decoupling between NC controller and control unit. Command value voltage matching is easily carried out. Excessive N command value produces only specified maximum speed.

One of the two available command value inputs is always active.

Suitable command value weighting is required for positioning, depending on the gear reduction ratio. C-axis operation requires high resolution for the speed command value.

Command value weighting for various speeds and C-axis operation is obtainable via parameter records (PQRS).

*Function conversion* The control unit must be fitted with the analogue command value interface (type code field "speed command value = A").

**Note:**

For noise immunity reasons (earth loops), connect screen of command value cable to controller only!

Avoid running command value line and power cable in parallel!

### 3. Controller Functions

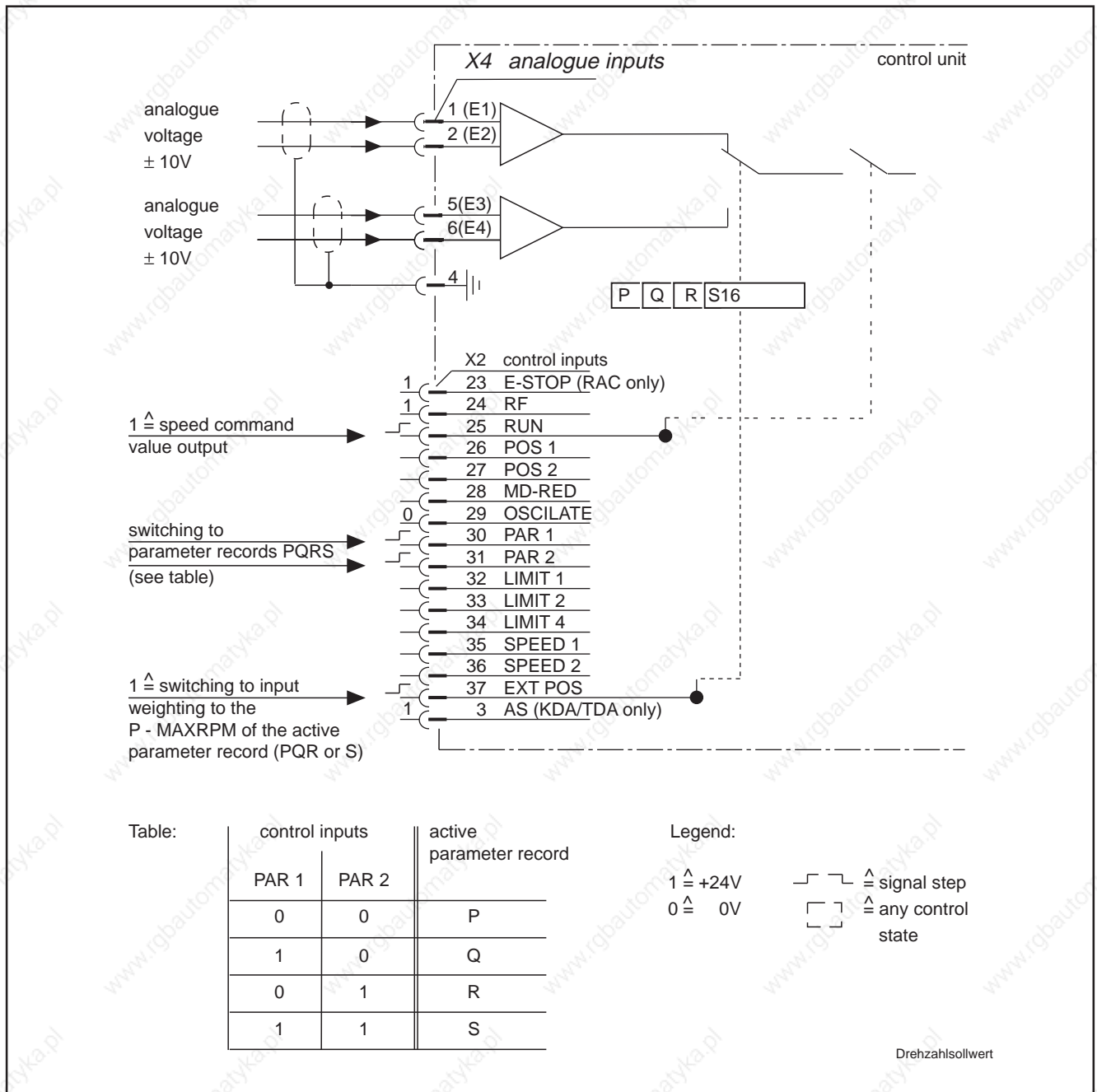

Figure 18: Inputs for analogue speed command value and control inputs

Parameter	Designation	Function	Value range or value
A 01	MAX RPM	maximum motor speed	1.....24000 ( 1/min )
A 02	CMD VOLT	analogue voltage value	6.0.....10.0 ( V )
P Q R S 15	P-MAXRPM	motor speed for additional input weightings	1.....24000 ( 1/min )
P Q R S 16	PQ-FUNCT	switching analogue inputs with switching of input weighting	< 1 >
A 05	FUNCT 1	analogue speed command value below MIN RPM is invalid!	< 2 >
A 03	MIN RPM	speed limit	1.....999 ( 1/min )
A 06	FUNCT 2	with EXTPOS = 1 is at analogue output N: 10V = P-MAXRPM	< 128 >

👉 PARAMETER PROTOCOL !

Para-Sollwert-Analog

Figure 19: Parameter for analogue speed command value

*Input weighting* **Note:** Command value weighting is CMDVOLT/MAXRPM, if control input EXTPOS is at 0.

If control input EXTPOS is at 1, then the weighting is CMDVOLT/P-MAXRPM. P-MAXRPM is part of the selected parameter record (P, Q, R or S). The voltage at the analogue output N can be output with parameter FUNCT2 with reference to P-MAXRPM.

*Input switching* Changing to the second differential input is effected with the EXTPOS control unit. In this case, the value in parameter PQ-FUNCT must be increased by <1> and EXTPOS must be at 1.

*Maximum/minimum speed command value* If the value of parameter CMDVOLT is less than 10 V, 10% of MAXRPM can be obtained by suitable voltage input. To prevent drift if the speed command value zero is affected by noise, a command value less than the value in the parameter MINRPM can be arranged to be invalid.

*Speed limiting* RPM is limited to 112 % of MAXRPM in the event of a fault!

*Possible error messages in the display*

- ADW2
- NO INPUT

### 3.2.2 Digital Speed Command Value (option)

The "digital speed command value" enables a task to be matched to the specific plant requirements.

The speed command value can be transferred directly from the PLC controller, binary or floating-point coded, depending on the required speed resolution. The parallel signals are interrogated by the control unit every 1.2 ms.

In plants with severe interference, and in the case of long lines, digital parallel transmission ensures high speed command value accuracy.

Speed command value resolution:

- binary coded 1 rpm
- floating-command coded to 0.0005 rpm

Parameter	Designation	Function	Value range or value
A 06	FUNCT 2	dig. speed comm. value, binary coded	< 0 >
		dig. speed comm. value, floating comma coded	< 2 >
A 01	MAXRPM	maximum speed of the motor	1...24000 ( 1/min )
A 05	FUNCT 1	weighting change of the digital speed command value with respect to parameter value of A 01:  $N_{\text{comm}_{A 01}} = \frac{A 01}{16383} \cdot N_{\text{comm}_{\text{digital}}}$	< 1024 >

 PARAMETER PROTOCOL !

Para-Sollwert-Digital

Figure 20: Parameters for a digital speed command value

**Function conversion** The control unit must be fitted with the digital command value interface (type code field "speed command value = D").

**Speed limits** The maximum speed of the motor MAX RPM is not exceeded, even with excessively high speed command values!

Binary Coding

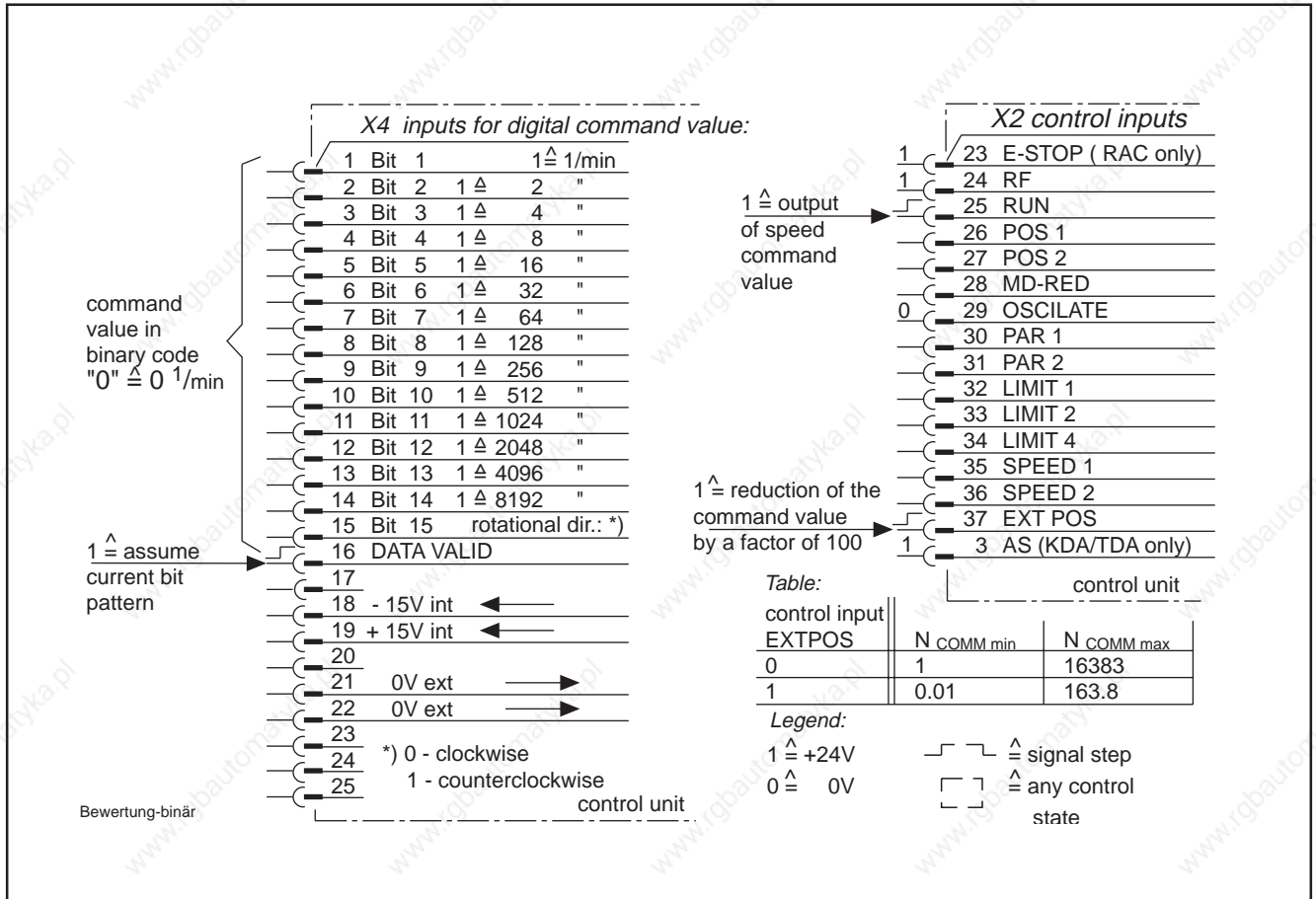

Figure 21: Inputs for digital speed command values, weighting for binary coding and control inputs

Speed command value validity

If the "DATA VALID" input is at 1, then the bit pattern is read continuously and is passed to the processor.

If the „DATA VALID“ input is at 0, then the bit pattern last read and passed to the processor is the effective speed command value.

Floating-Point Coding

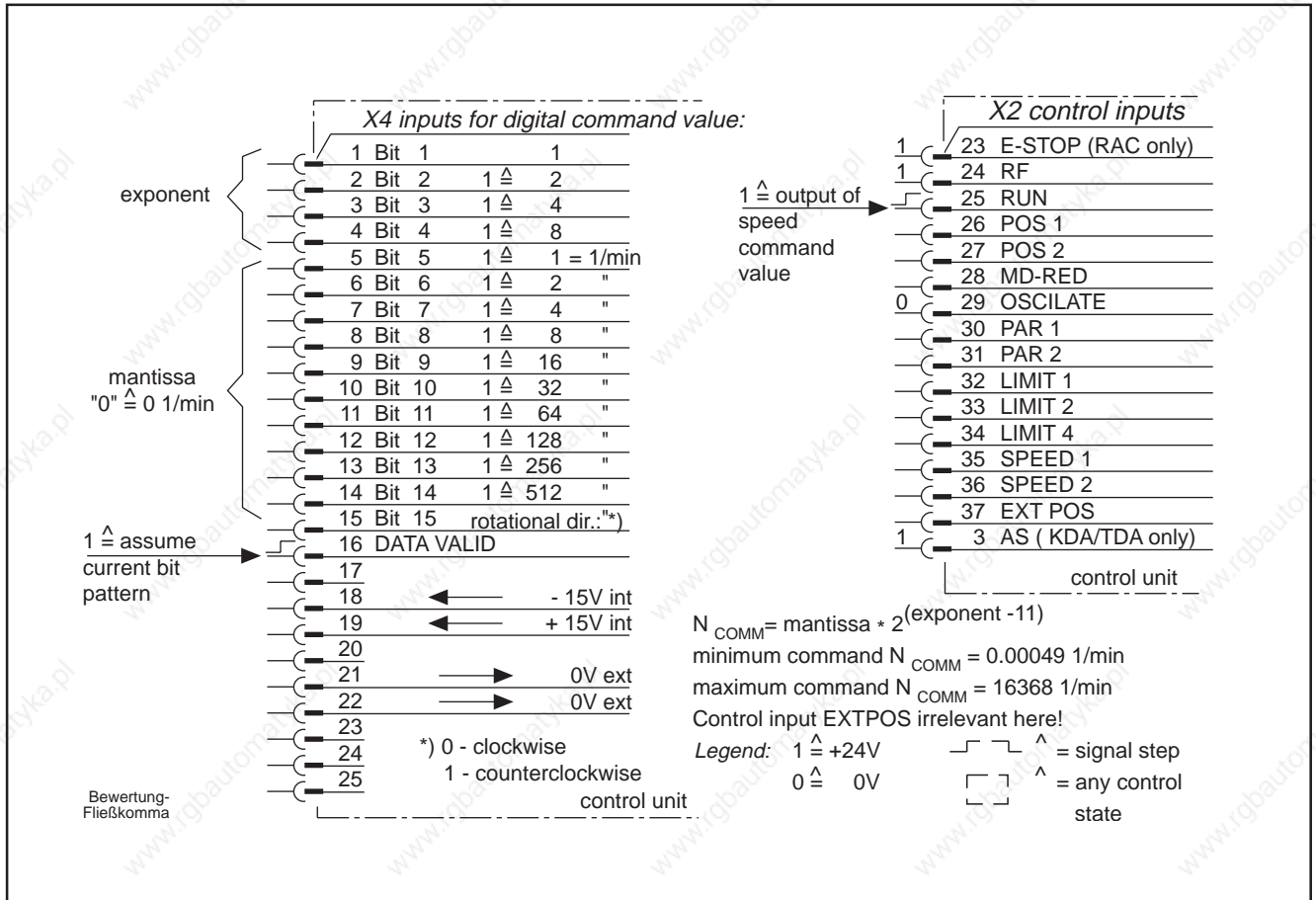

Figure 22: Inputs for digital speed command value, weighting for floating-point coding

Speed command value validity

If the "DATA VALID" input is always at 1, the bit pattern is read continuously and is passed to the processor.

If the "DATA VALID" input goes to 0, then the bit pattern last read and passed to the processor is the effective speed command value.

Possible error message in display

NO INPUT

### 3.3 Main Spindle Speed Signals

The main spindle speed determines the time point of the feed enabling signal, gear change and clamping of the holding brake.

The requirements are met if signal output „ $N_{act} = N_{comm}$ “, „ $N < N_{min}$ “ and the selectable torque disconnect is below  $N_{min}$ . The signal operating thresholds can be set as required.

Function conversion

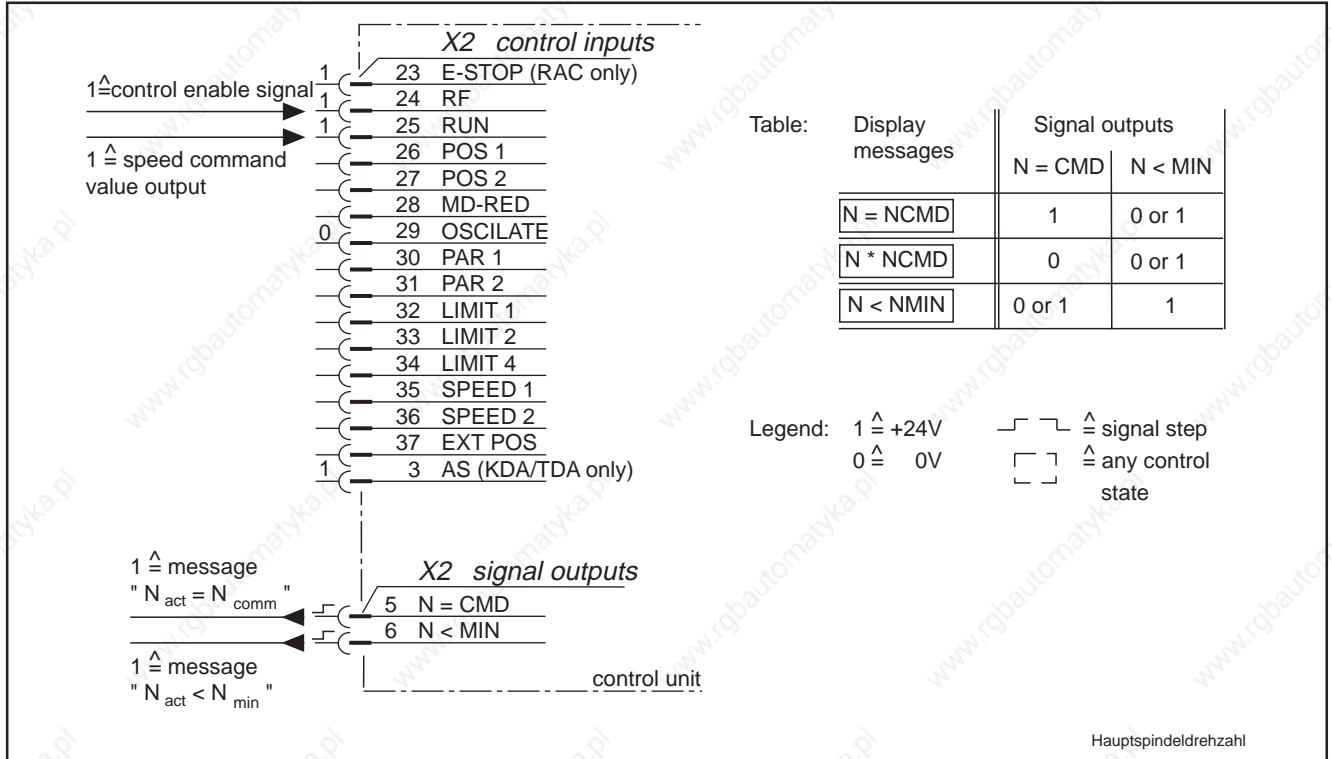

Figure 24: Control inputs, signal outputs, displays for main spindle speed

**Note:**

The display message „N \* NCMD“ means  $N_{act} \neq N_{comm}$ . This appears when the speed is above the minimum speed, but has not yet reached the command value speed.

Parameter	Designation	Function	Value range or value
A03	MIN RPM	if speed command value and motor speed are under MIN RPM, then signal output "N < MIN" goes to 1	1.....999 ( 1 / min )
A04	MAX DEV	maximum deviation of speed from command value within which signal output " N = CMD " goes to 1	1.....999 ( 1 / min )
A05	FUNCT 1	signal output " N = CMD " also signals without RF enabling signal (control input RF = 0)	< 256 >
		change of input value of " MAX DEV "; 1 = 0.1% of current Ncommand	< 512 >
		torque off if speed is less than value in MINRPM	< 4 >
PQR S 16	PQ-FUNCT	independent of speed command value, signal output "N < MIN" goes to 1 if motor speed less than MIN RPM (A 03)	< 512 >

Parameter protocol ! Parameter Hauptspindel

Figure 25: Parameter for main spindle speed signals

**Note:** When the values of parameter „MAX DEV“ (A04) are input as per cents of the speed command value, then the smallest deviation is limited to 10 rpm.

**Motor standstill** Furthermore, when the drive is stopped with the controller enable signal switched off (RF control input=0), the controller can check standstill via the signal output "N=CMD" (speed command value must be 0!).

**Torque disconnect** Torque disconnection is compatible via function parameters if the motor speed is less than the value in parameter MINRPM. This is useful if the motor has to be locked in the stopped position after controller braking, but the controller enabling signal does not have to be disconnected.



**The signal „N < MIN“ does not meet personnel protection needs in the working area of the main spindle!**

### 3.4 Speed Command Value Ramps

In many cases in main spindle drives it suffices to apply the speed command value via simple control devices (PLC and the like). Sudden changes in the speed command value can be converted in the control unit to ramp-type characteristics.

Three different selectable, successive ramp slopes are available in the controller. They can be used, for example, for breakaway damping and limiting the acceleration for belt couplings. In the constant-power range, the torque is reduced via the speed. In this case, the regulation can be maintained in the active area by means of the third ramp (constant speed increase).

Different ramp slopes can be entered for a maximum of four speed reduction stages.

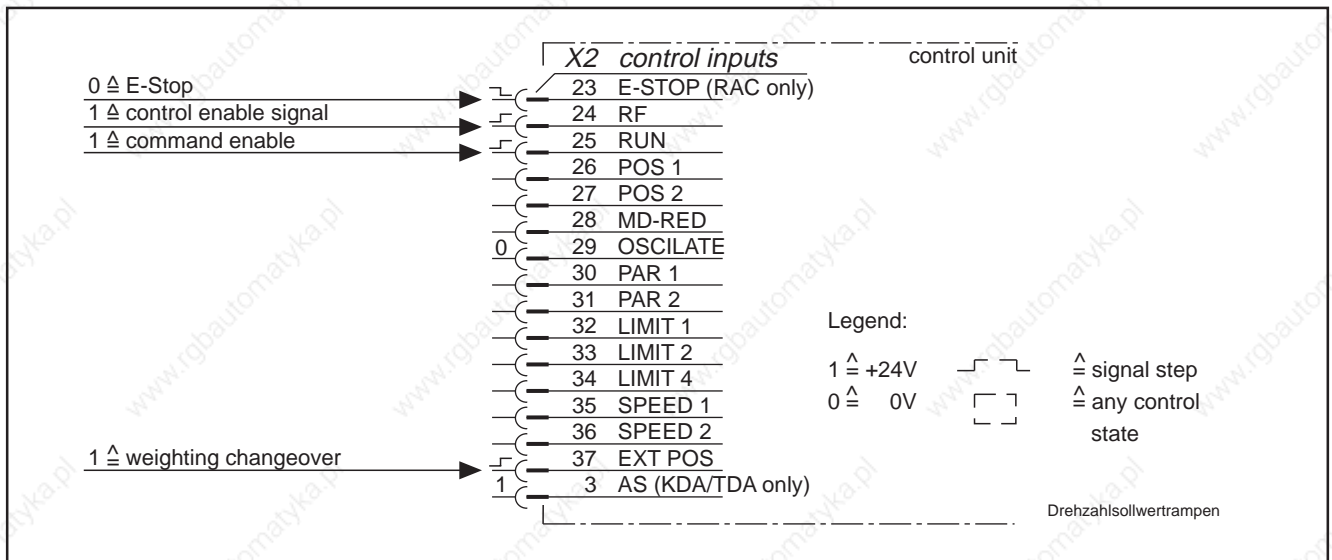



Figure 26: Control inputs affecting the speed command value ramps

**Ramps** The specified ramps are active when the controller enabling signal (RF) and the speed command value enable signal (RUN) are switched on and off!

### 3. Controller Functions

Parameter	Designation	Function	Value range or value
SRQ P01	RAMP 1	ramp 1 switched off	0
		gradient of ramp 1	1.....999 (rad / s <sup>2</sup> )
SRQ P02	RPM 1	end speed of ramp 1	1.....24000 (1 / min)
SRQ P03	RAMP 2	ramp 2 switched off	0
		gradient of ramp 2	1.....999 (rad / s <sup>2</sup> )
SRQ P04	RPM 2	end speed of ramp 2	1.....24000 (1 / min)
SRQ P05	RAMP 3	ramp 3 switched off	0
		gradient of ramp 3	1.....999 (rad / s <sup>2</sup> )
A06	FUNCT 2	the ramp set is also active - switching EXT POS and power failure (all controllers) - switching of E-STOP (RAC only)	< 32 >

 Parameter protocol !

Para.Drehzahl Sollwert rampe

Figure 27: Parameters for speed command value ramps

If the ramps are to remain active during a change of weighting (EXT POS), during an E-stop and mains off, this must be specified via function parameters.

**Note:**

All three ramps must be set when the ramp function is used. Slopes must be entered in rad/s<sup>2</sup> (see Figure 27 for conversion).

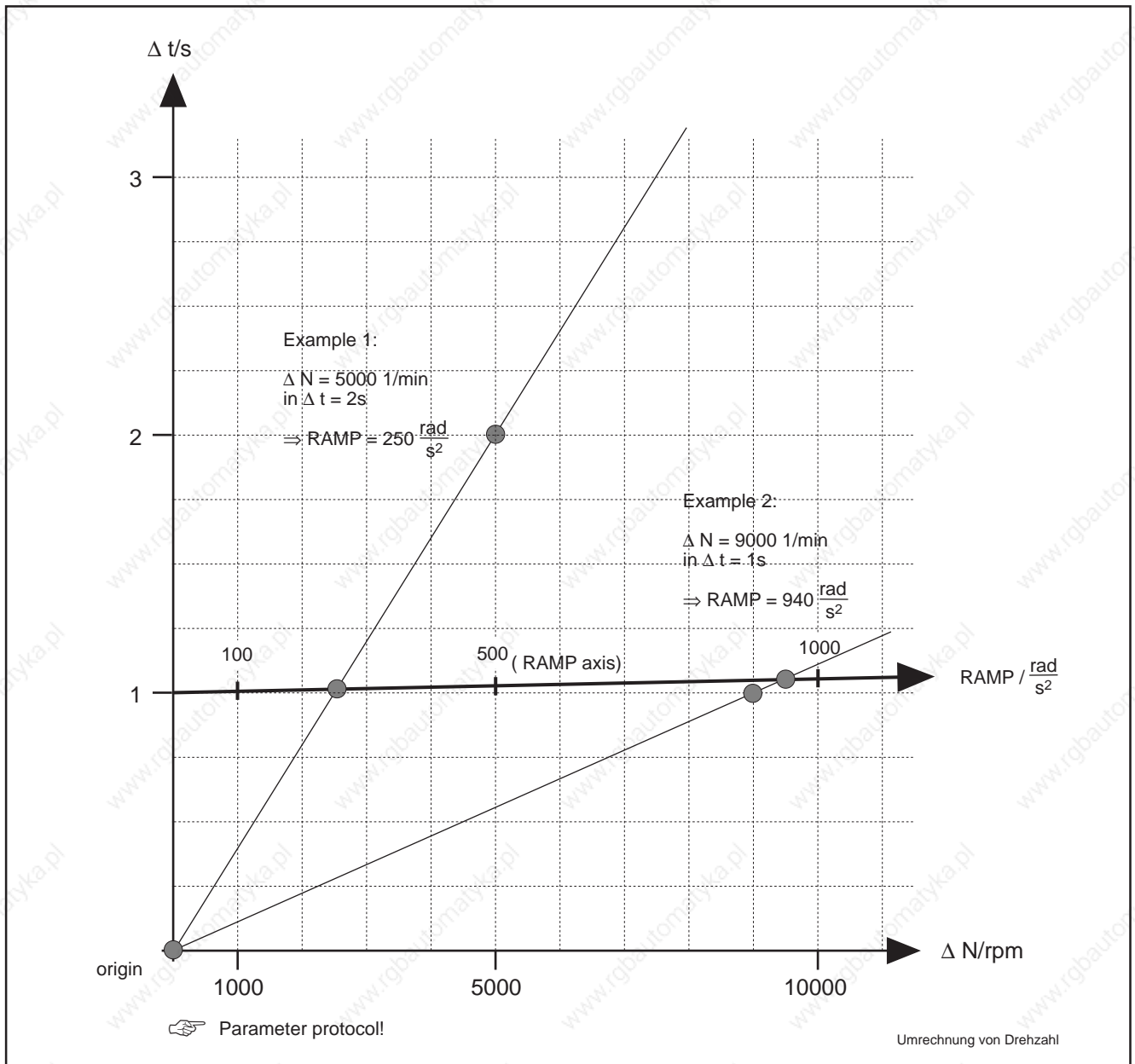

Figure 28: Converting speed  $\Delta N$  and slope times  $\Delta t$  in RAMP ( $\text{rad/s}^2$ )

*Instructions for using the conversion graph*

Slope values must be entered in  $\text{rad/s}^2$  (see Figure 28 for conversions).

- Determine your desired end speed  $\Delta N$  in rpm and the necessary time period  $\Delta t$  in seconds (s).
- Mark the point corresponding to the combined values of  $\Delta N$  and  $\Delta t$  on the graph.
- Draw a straight line through the marked point and the origin of the graph.
- Read the slope of your desired ramp in  $\text{rad/s}^2$  at the intersection of the straight line and the RAMP axis and enter the respective RAMP parameter (see example).

*Conversion formula (alternative to conversion graph)*

$$\text{RAMP} = \pi/30 * \Delta N/\Delta t * \text{min/s} \quad (\Delta N \text{ in rpm and } \Delta t \text{ in s})$$

Function sequence graph

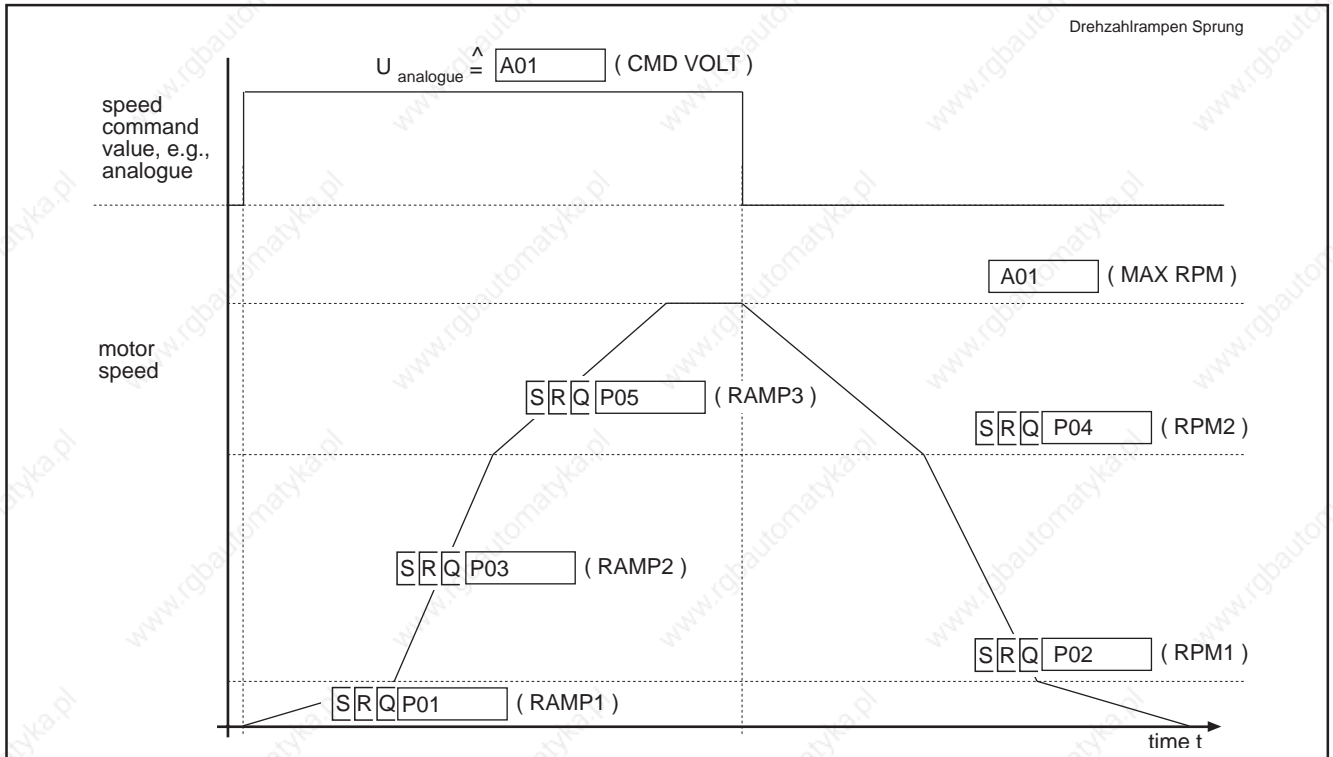

Figure 29: Speed ramps for step change in speed command value

### 3.5 Command Value Smoothing

When controlling the main spindle drive along a ramp via the NC controller or when operating in positioning mode, staircase changes in command values by the NC controller cause sudden torque changes. The speed command value can be smoothed to dampen these.

Adjustable smoothing time constants provide matching to different NC clock times and mechanical conditions for the various speed reduction stages!

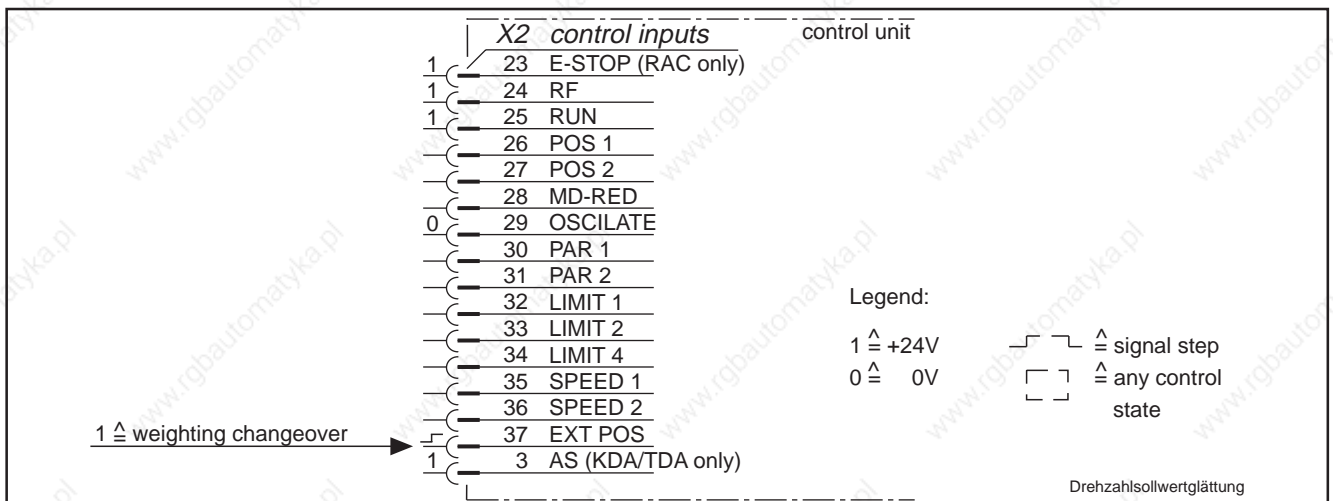

Figure 30: Control inputs affecting speed command value smoothing

Smoothing and weighting selection

**Note:** The speed command value smoothing is inoperative when the input weighting (EXTPOS=1) is changed. However, it can be made operative via parameters when EXTPOS=1.

### 3. Controller Functions

Parameter	Designation	Function	Value range or value
P01	RAMP 1	Value for smoothing time constant	0 to 11
P02	RPM 1	no function, but defined value 0 is needed!	0
P03	RAMP 2	" " " " " "	0
P04	RPM 2	" " " " " "	0
P05	RAMP 3	" " " " " "	0
A06	FUNCT 2	the smoothing set is also active with: control input EXT POS = 1	< 32 >

Parameter protocol! Para-Drehz-Glätt

Figure 31: Parameters for smoothing speed command value

**Smoothing time constant** **Note:** Smoothing is achieved via a digital filter. The smoothing time constant is calculated as follows:

$$T_g = 0.5 \times 2^{\text{RAMP1}} \text{ ms}$$

In the same parameter record the speed command value smoothing excludes the speed ramp function.

Speed command value smoothing is possible for both analogue and digital command values.

### 3.6 Spindle Positioning

Three standard spindle positions can be set for the drive via the controller for simple and rapid tool change on milling centers.

If more than three positions are required, for example,

- for aligning the tool to the workpiece contour on milling machines,
- indexing the workpiece on lathes, or,
- positioning workpieces for balance holes on balancing machines,

then 3600 optional selectable spindle positions are available.

*Positioning accuracy*

The position command values can be accurately set to 0.1 angular degrees and are corrected to a maximum of 1/1000th of an angular degree.

Three modes of mechanical coupling between motor and spindle make different types of positioning possible.

types of mechanical coupling \ positioning process	Spindle positioning with the use of.....		
	... motor feedback	... motor feedback + spindle homing switch	... spindle feedback
rigid gears, $i = 1 : 1$	X		
changeover gears, $i = \text{any}$		X	
gears with slip, $i = \text{any}$			X
	see sections 3.6.1 and 3.6.2	see sections 3.6.1 and 3.6.3	see sections 3.6.1 and 3.6.4

Mechanische Kopplung

Figure 32: Mechanical coupling and positioning methods

### 3. Controller Functions

The three spindle positioning methods:

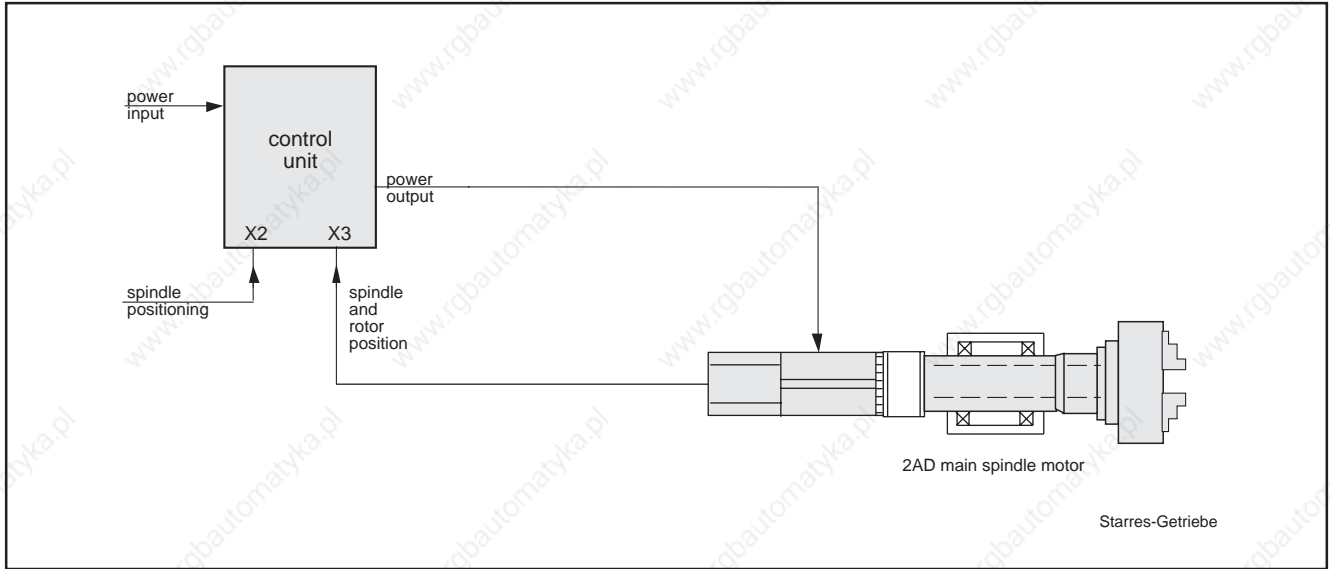

Figure 33: Spindle positioning via motor feedback with solid gearing,  $i = 1$

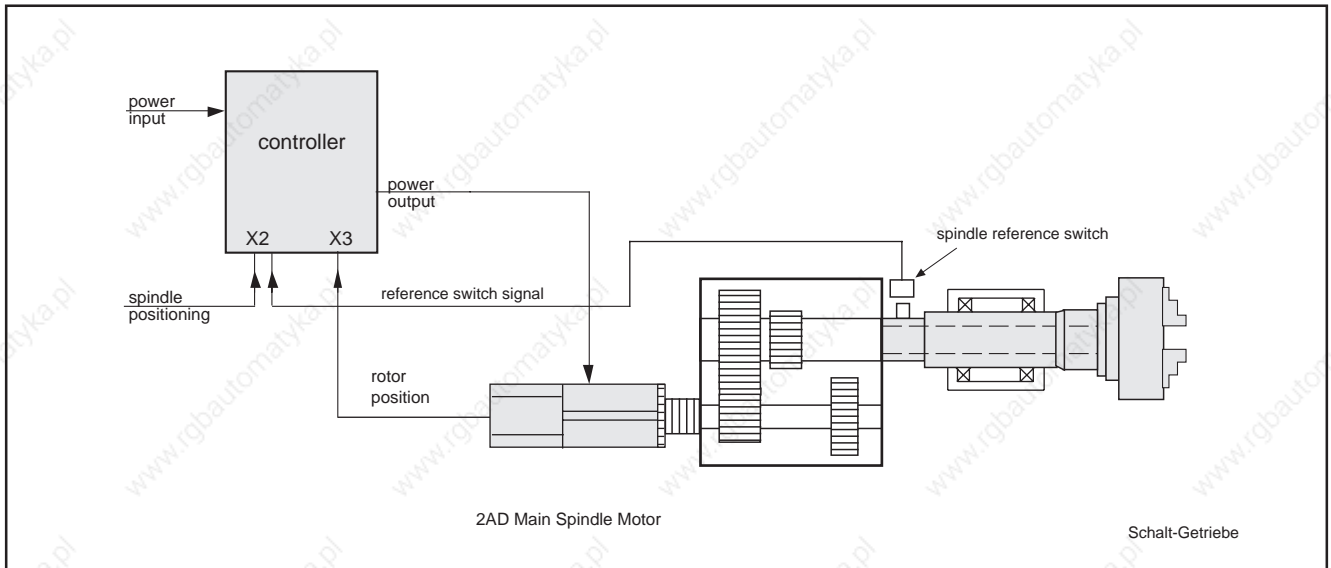

Figure 34: Spindle positioning via motor feedback with spindle reference switch and change speed gear

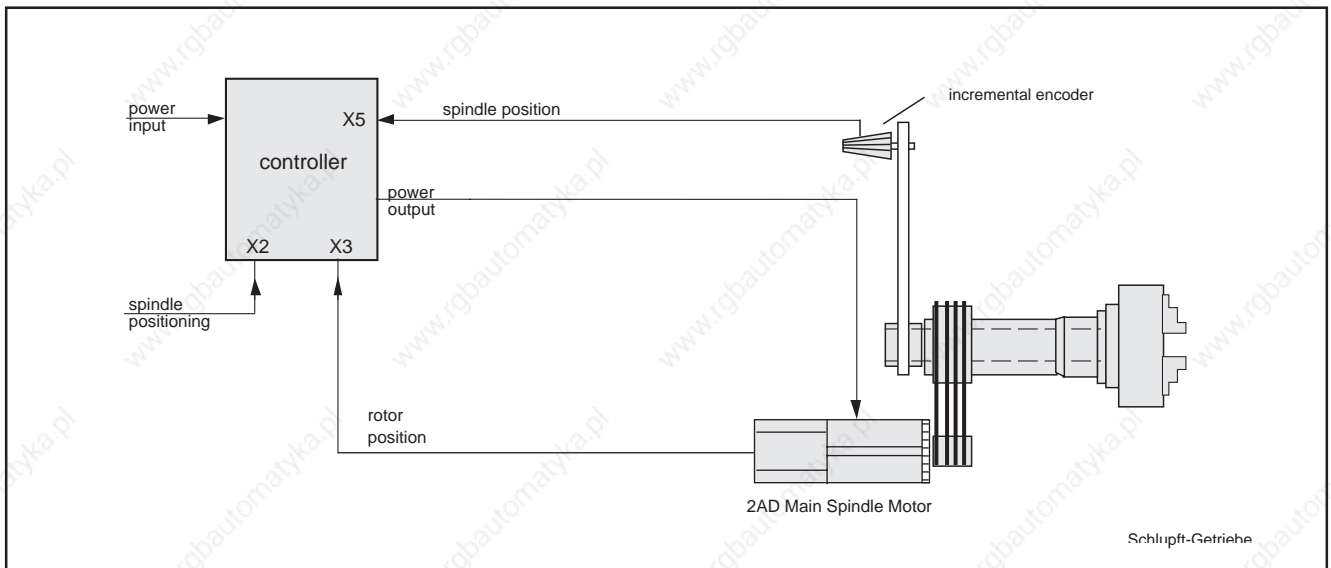

Figure 35: Spindle positioning via spindle feedback with gearing subject to slip

### 3.6.1 Basic Data for Spindle Positioning

Function conversion:

a) Standard version - three spindle positions

- Inhibit the speed command value at the control unit by removing the RUN control signal from the PLC.
- Binary selection of one of the three spindle positions via control signals POS1 and POS2 from the PLC.

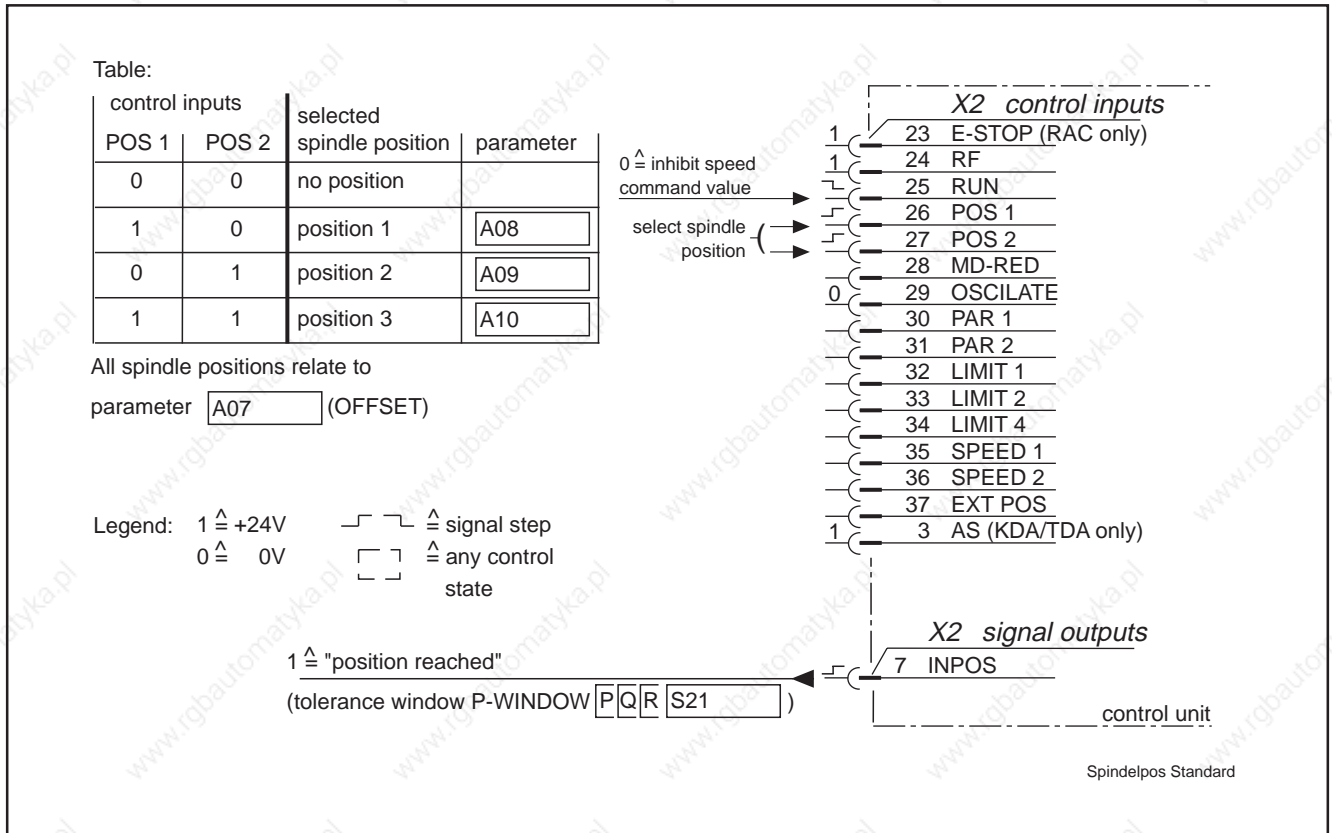

Figure 36: Control inputs and signal outputs for spindle positioning (standard unit)

**Note:**

If "no position" has been selected, the drive brakes to a standstill and remains under speed control without drift. The display then shows NO RUN.

The drive switches back to speed control when the speed command value is enabled (RUN = 1).

### 3. Controller Functions

Parameter	Designation	Function	Value range or value
A07	OFFSET	angular offset of the zero pulse and the spindle reference point	0.....360.0 (°)
A08	POS 1	spindle position 1	0.....360.0 (°)
A09	POS 2	spindle position 2	0.....360.0 (°)
A10	POS 3	spindle position 3	0.....360.0 (°)
A06	FUNCT 2	positioning direction (valid in all switching parameter records PQRS) - shortest path - relevant qualifying sign of speed command value	< 0 >  < 16 >
S R Q P16	PQ-FUNCT	positioning direction valid only in the presently active PQRS parameter record; A06 may not be <16> ! - shortest path - relevant qualifying sign of speed command value	< 0 > (A06 ≠ < 16 > !!)  < 128 > (A06 ≠ < 16 > !)
S R Q P17	POS GAIN	gain factor in position control loop 16.6 = Kv = 1	0.....99.9 (1/s)
S R Q P18	POS RPM	positioning speed (limited to 30*POSGAIN)	0.....9999 (1/min)
S R Q P21	P-WINDOW	tolerance window within which the message "INPOS" is issued	0.01.....99.99 (°)
S R Q P12	GEAR IN	gear ratio $i = \frac{N_1}{N_2}$	N <sub>1</sub> 1.....999
S R Q P13	GEAR OUT		N <sub>2</sub> 1.....999

☞ Parameter protocol !

Para-Spindel

Figure 37: Parameters for spindle positioning (standard)

**Note:**

The parameter values refer to the spindle.

The spindle position values refer to the OFFSET values (for details on OFFSET, see positioning procedure).

*Direction of positioning*

The direction of positioning can be specified in the FUNCT 2 parameter (A06) for the shortest path or according to the sign of the applied speed command value. This arrangement is then valid in each of the selectable parameter records P, Q, R and S.

*Changing the direction of positioning*

If the positioning direction has to be specified for each of the selectable parameter records via PQ FUNCT (PQRS 16), then A06 must not contain the value <16>!

3600 spindle positions Precondition is that the interface for digital position input must be fitted to control unit (type code field "additional interface" = D).

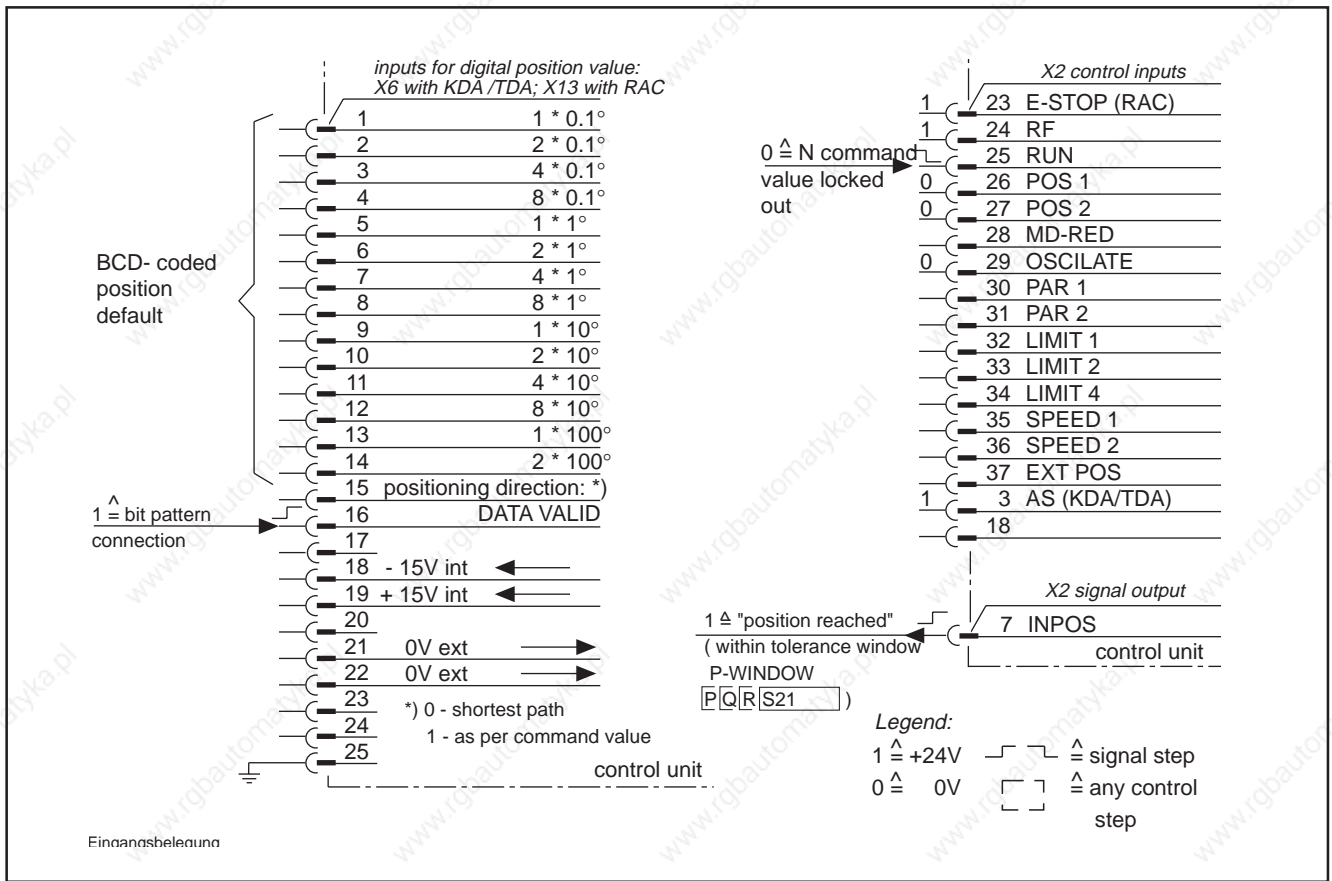

Figure 38: Allocation of inputs for digital position command, control inputs and signal outputs

Entering position command value

Note:

The applied speed command value must also be inhibited when entering digital position command values (RUN control input must be 0).

The bit pattern at the digital interface is switched through to the control unit by means of the DATA VALID input. If the bit pattern changes while the DATA VALID input is at 1, the drive moves immediately up to the new position.

Priority of the position command value

The three parameter-specific positions have priority over the digital position input. The control inputs POS1 and POS2 must therefore be set to 0!

### 3. Controller Functions

Parameter	Designation	Function	Value range or value
A07	OFFSET	angular offset of the zero pulse and spindle reference point	0.....360.0 (°)
P17	POS GAIN	gain factor in position control loop $16.6 \triangleq K_v = 1$	0.....99.9 (1/s)
P18	POS RPM	positioning speed (limited to 30*POSGAIN)	0.....9999 (1/min)
P21	P-WINDOW	tolerance window within which the message "INPOS" is issued	0.01.....99.99 (°)
P12	GEAR IN	gear ratio $i = \frac{N_1}{N_2}$	$N_1$ 1.....999
P13	GEAR OUT		$N_2$ 1.....999

Parameter protocol ! Para-Spindel-3600

Figure 39: Parameter for spindle positions (3600 positions)

**Note:**

The parameter values refer to the spindle. The digital spindle position command values refer to the OFFSET parameter (for details on OFFSET see positioning procedure).

3.6.2 Spindle Positioning via Motor Feedback

Parameter	Designation	Function	Value range or value
SRQ P16	PQ-FUNCT	rotational direction of motor and spindle	- same
			- opposite

Parameter protocol ! Para-Spindel-zusatz

Figure 40: Additional parameters to 3.6.1 for spindle position via motor feedback

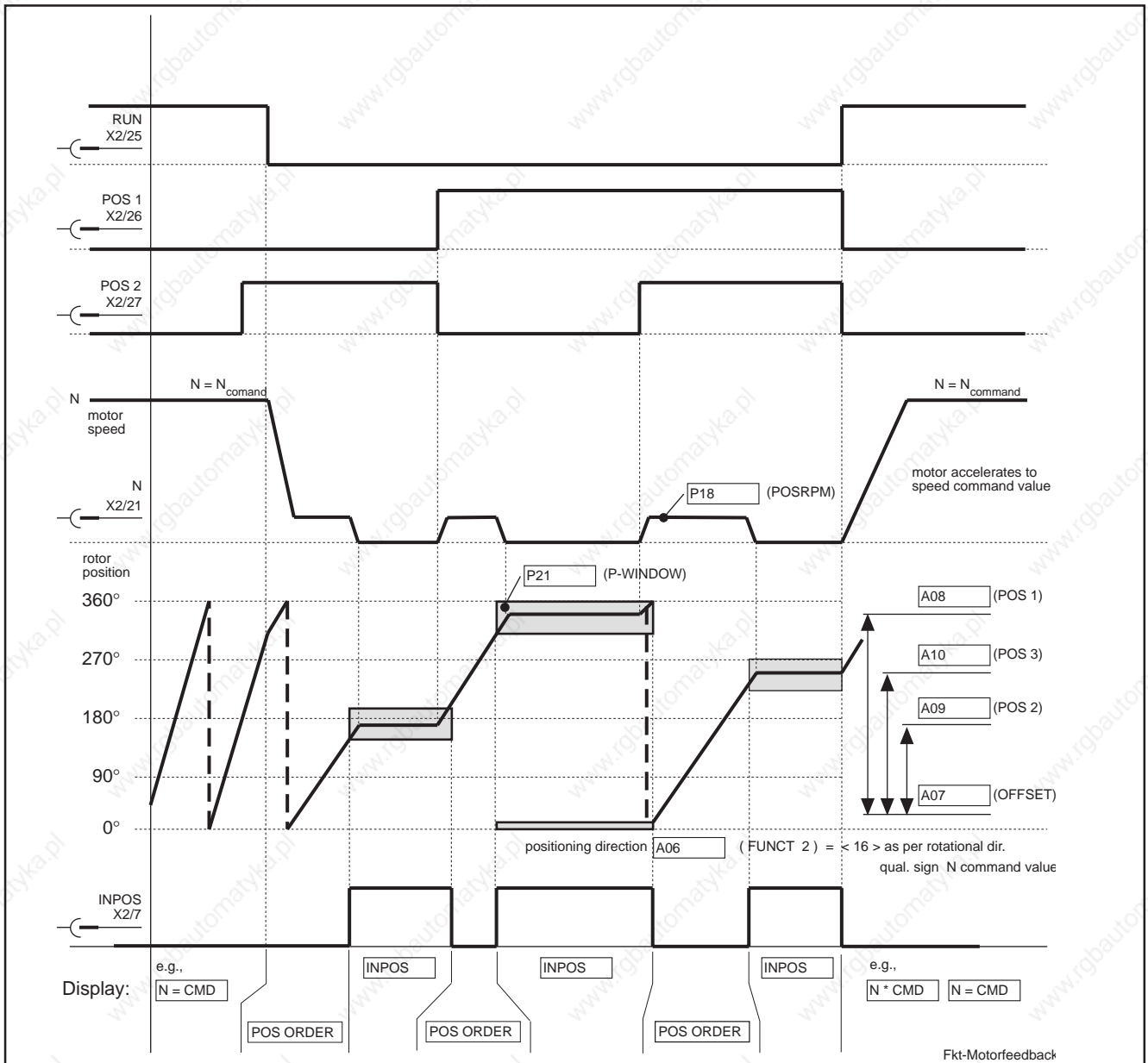

Figure 41: Operating sequence of spindle positioning via motor feedback (e.g., direction of rotation as per sign of applied speed command value)

**Positioning accuracy** The positioning accuracy of motor feedback type 1 is 0.1 angular degrees and 0.001 angular degrees for motor feedback type 3 (see type code field "Motor Feedback" of motor in use).

### 3.6.3 Spindle Positioning via Motor Feedback with Spindle Reference Switch

Parameter	Designation	Function	Value range or value
SRQ P16	PQ-FUNCT	- same	< 0 >
		rotational direction of motor and spindle	
		- opposite	< 2 >
		spindle reference switch signal to X2/37	< 64 >
		Note: invalid value	<del>&lt; 65 &gt;</del> !
SRQ P15	P-MAXRPM	Here: spindle speed for searching the reference switch signal	1.....24000 1/min

Parameter protocol! Para-Spindel-refer

Figure 42: Additional parameters for spindle positioning via motor feedback

#### Reference switch search direction

The sign of the reference switch search speed (P MAXRPM) corresponds to the sign of the speed command value that applies when positioning is initiated (control input RUN 1->0). If the speed command value at the time has to be switched to zero by the controller, then positive or negative speed can be set for locating the reference switch signal.

#### Information about the spindle reference switch

- The reference switch signal from the spindle must be connected to the EXT POS control input.
- The angle  $a_{\min}$  is the minimum  $\geq 0^\circ$  of the spindle reference switch. The maximum reference point detection error is given by the angle  $a_{\min}$  and the hysteresis of the spindle reference switch.  
The affect of the hysteresis can be eliminated, if the reference switch signal is always searched for in the same direction. In this case, the speed command value must always have the same sign when positioning is initiated.
- $a_{\min}$  depends on the search speed of the reference point on the spindle. Search speed is the value of parameter P-MAXRPM.

### 3. Controller Functions

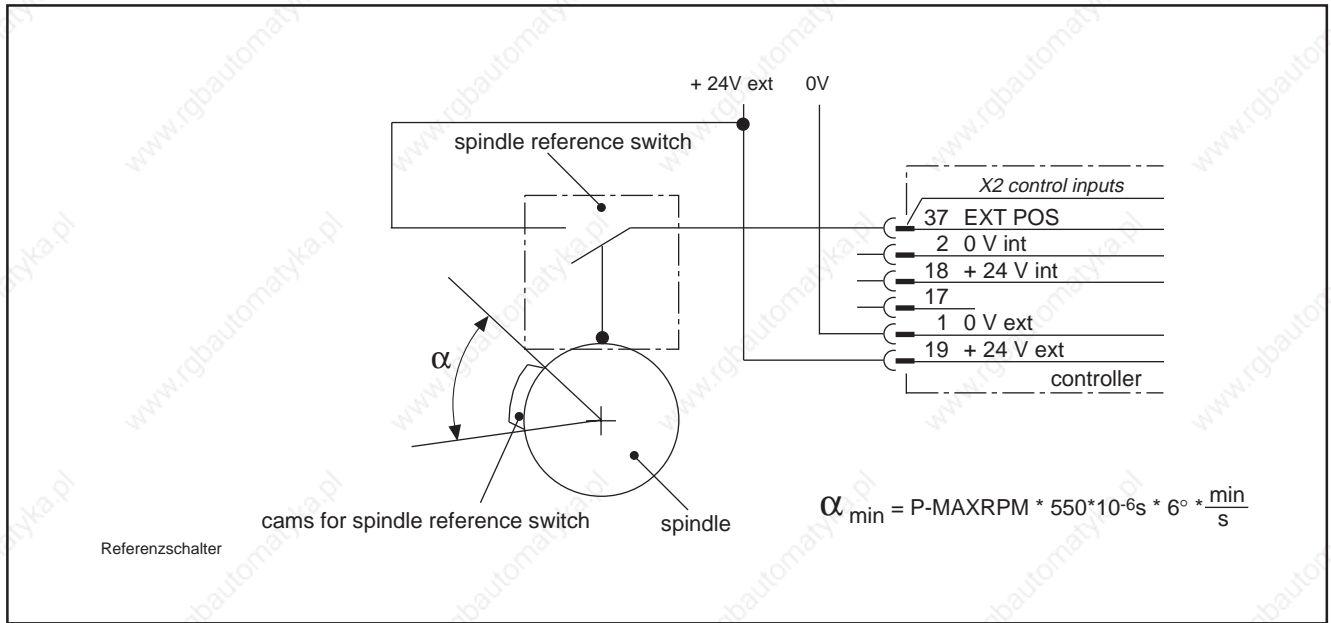

Figure 43: Reference switch connections and dwell angle

#### Note:

The reference switch can, e.g., be an inductive proximity switch such as one of the Balluf BES 516 series.

A shielded cable must be used to connect the spindle reference switch. Connect shield to X2/17. Do not run in parallel with power cables!



**Since the INPOS message can only be obtained by indirect comparison of command value and actual position, the spindle position should be monitored by a second proximity switch, since the machine can be damaged by position errors!**

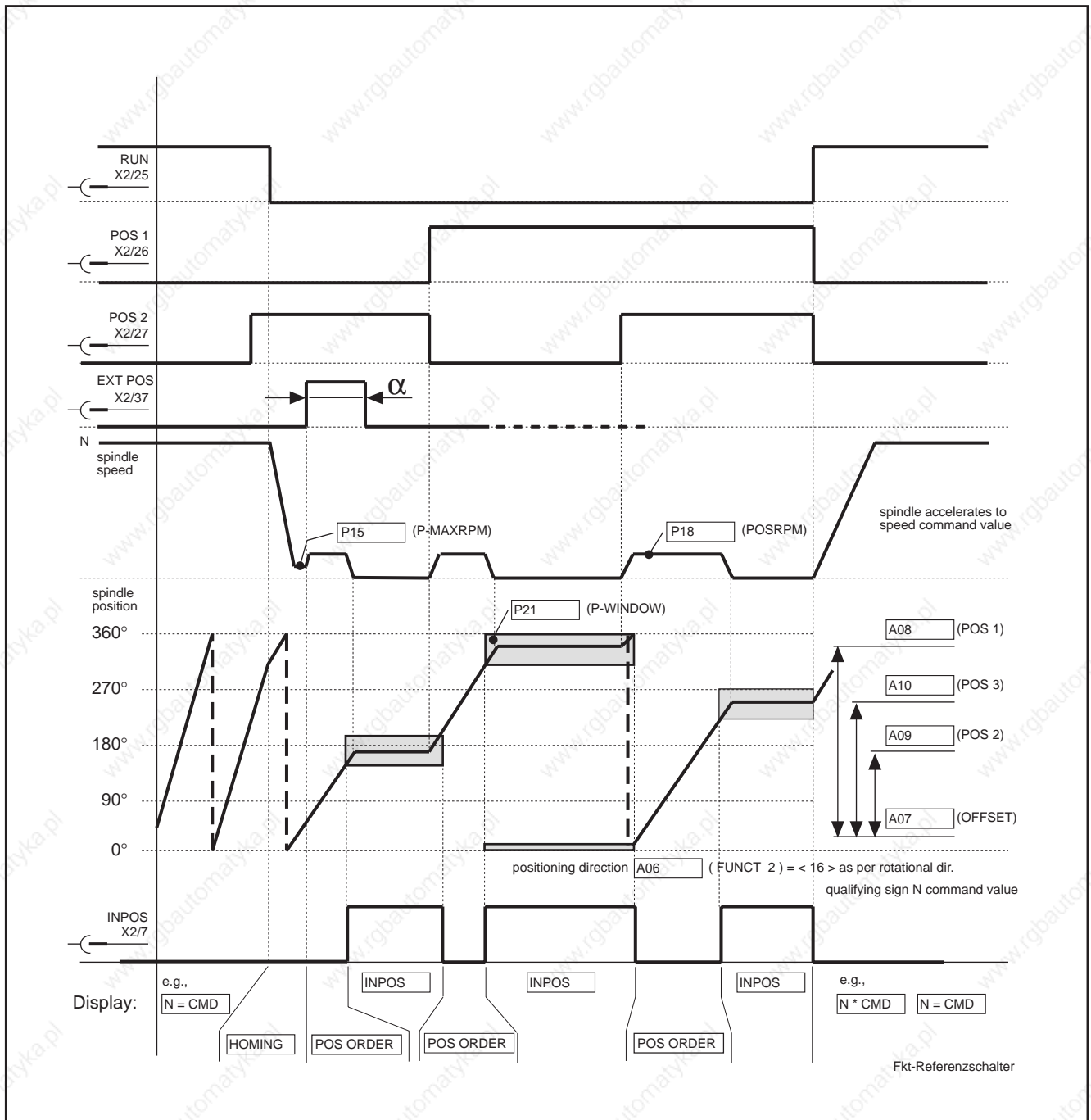

Figure 44: Operating sequence for spindle positioning via motor feedback with reference switch (e.g., direction of rotation as per sign of applied speed command value)

**Rising edge of reference switch**

The OFFSET parameter refers to the rising edge of the reference switch pulse for clockwise rotation and the trailing edge for counterclockwise rotation of the spindle. The same edge of the reference switch pulse is evaluated for either.

**Positioning accuracy**

The value of the OFFSET parameter is the angle between the reference point for spindle positioning and the edge of the reference switch pulse.

The positioning accuracy for motor feedback type 1 (see "motor feedback" type code of motor in use) is 0.1/i angular degrees, and 0.001/i angular degrees for motor feedback type 3.

**Possible fault message**

HOMING remains on the display.

### 3.6.4 Spindle Positioning via Spindle Feedback

A precondition is that the control unit is fitted with the interface for the second encoder input (type code field "second encoder input" = P).

The incremental encoder fitted to the spindle must be compatible with ROD 420/426 (5V supply voltage).

The Indramat high-resolution encoder used for spindle feedback can only be evaluated at high resolution in conjunction with the incremental encoder output or "Sercos" interface (type code "additional interface"=1).

Parameter	Designation	Function	Value range or value
SRQ P16	PQ-FUNCT	- same	< 0 >
		- opposite	< 2 >
A05	FUNCT 1	positioning not via spindle feedback, but via motor feedback	< 8 >
A11	ENCODER 2	lines, if an incremental encoder is used as spindle feedback	128 to 8192
		spindle feedback is high-resolution INDRAMAT encoder:	
		with ø 128 mm (256 teeth)	< 3 >
		with ø 256 mm (512 teeth)	< 4 >

 Parameter protocol ! Para-Spindel-lage

Figure 45: Additional parameters to 3.6.1 for spindle positioning via spindle feedback

#### Positioning accuracy

When an incremental encoder is used, the spindle positioning accuracy depends on the number of lines used.

If an Indramat high-resolution encoder is used and the control unit is modified as above, the spindle positioning accuracy is 1/1000th of an angular degree. (For further information on Indramat high-resolution main spindle position encoders, refer to document number 9.552.247.4.)

### 3. Controller Functions

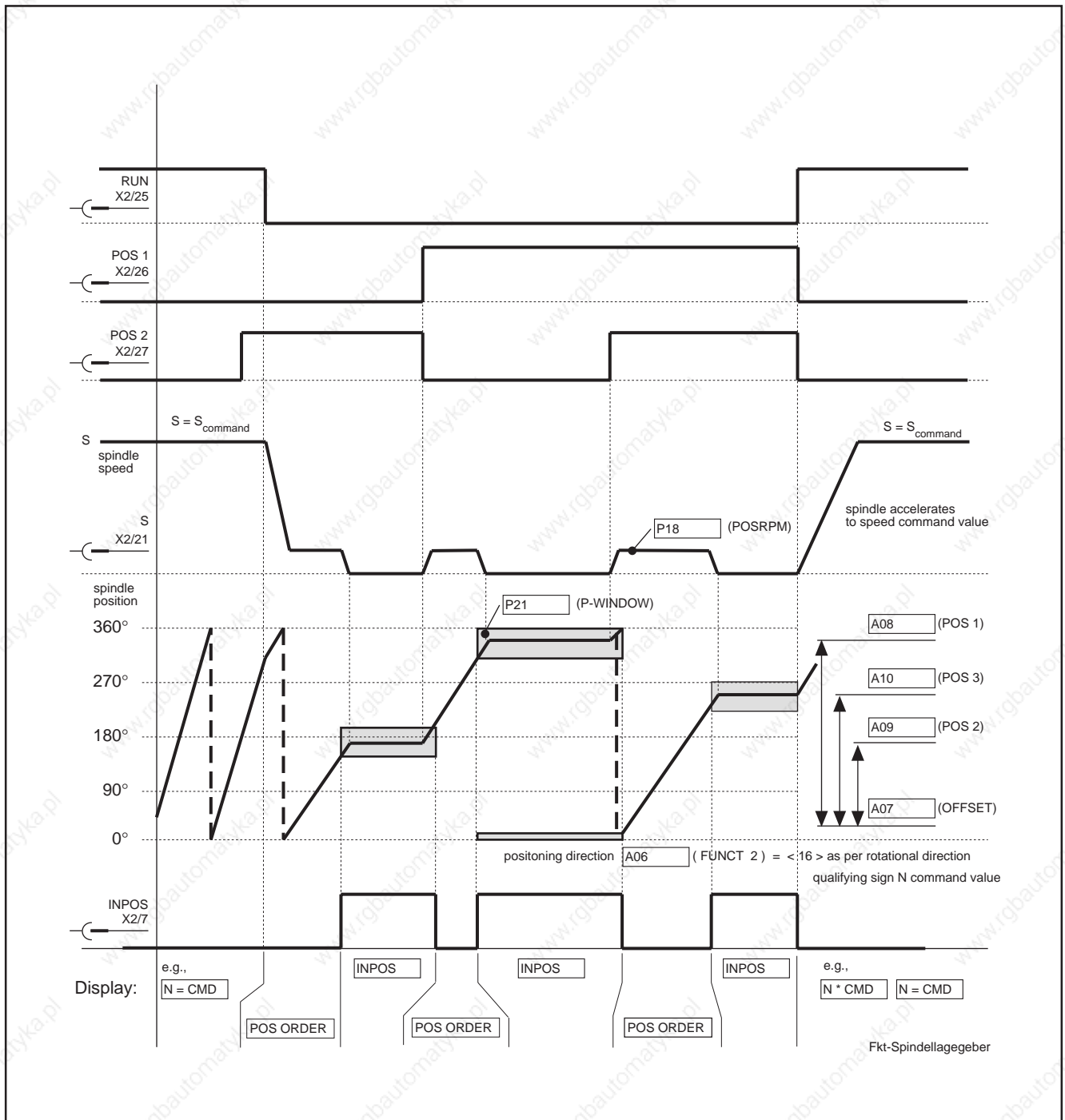

Figure 46: Operating sequence for spindle positioning via spindle feedback (e.g., direction of rotation as per sign of applied speed command value)

**Note:**

The value of the OFFSET parameter is the angle between the spindle positioning reference point and the spindle feedback zero pulse.

### 3.7 Speed Controller Functions

When changing the speed or changing the operating mode of the drive from the main spindle to the C-axis servo function, different mechanical systems make different demands on the speed controller.

**Torque build-up** Four different parameter records, which can be called up via control inputs, are available. Specified speed control parameters are in each of these parameter records for the appropriate mechanical coupling or operating mode.

**Ramp function** Because of the wide speed range, the main spindle drive operates in the constant torque or constant power range regardless of speed. This also requires the speed controller to be changed over according to the speed.

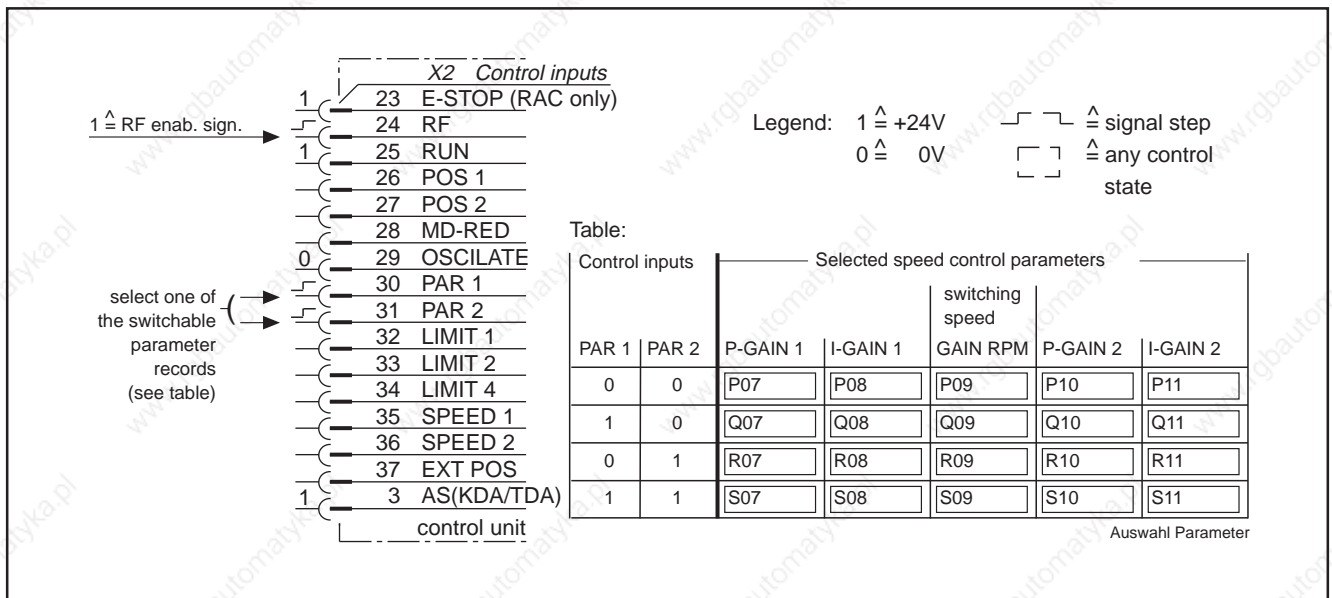

Figure 47: Control inputs for selecting the switchable parameter records

**Note:**

The motor is sufficiently magnetized and can provide the full torque only 200 ms after the controller enabling signal (RF = 1). The command value is inhibited during this interval.

If the controller enabling signal (RF) switches to 0 while the drive is turning, then the drive will brake at a set ramp until it reaches the zero velocity and only then becomes torque-free. If neither a ramp nor torque reduction are set, then the drive will brake at maximum torque!

### 3. Controller Functions

Parameter	Designation	Function	Value range or value
P07	P-GAIN 1	P-gain of the speed controller below switching speed	0.....20.00
P08	I-GAIN 1	I-gain of the speed controller below switching speed	0.....20.00
P09	GAIN RPM	switching speed from P-I-Gain1 to P-I-Gain2	0.....9999 (1/min)
P10	P-GAIN 2	P-gain of the speed controller above switching speed	0.....9.99
P11	I-GAIN 2	I-gain of the speed controller above switching speed	0.....9.999
A03	MIN RPM	speed limit	1.....999 (1/min)
A05	FUNCT 1	general switch off of I-gain of the speed controller at $N_{\text{command}}$ below MINRPM	< 16 >
P16	PQ FUNCT	parameter-dependent switch off of I-gain of the speed controller at $N_{\text{command}}$ below MINRPM	< 4 >
M03	T-FILTER	time constant value of the tachometer filter	0.....3

Parameter protocol! Para-Drehz-Fkt

Figure 48: Parameter for speed controller functions

#### Speed dependent changeovers

Changeover from P-I-GAIN 1 into P-I-GAIN 2 is automatic if the speed of the motor is below the value of GAIN RPM.

The drive automatically switches to P-GAIN 2 and I-GAIN 2 at the speed in parameter I-U-RPM (M09), even if GAIN RPM was set higher!

#### Braking without overshoot

For braking without overshoot, for a speed command value of less than MINRPM, the drive can be switched to pure P-control. This is always achieved with the FUNCT 1 parameter (A parameter), but only with the PQ FUNCT parameter (PQRS parameter) in the respective, active parameter record.

The drive can also be run with true P or I control (value 0 is set for the other respective parameter).

Further information about the speed controller and tachometer filter.

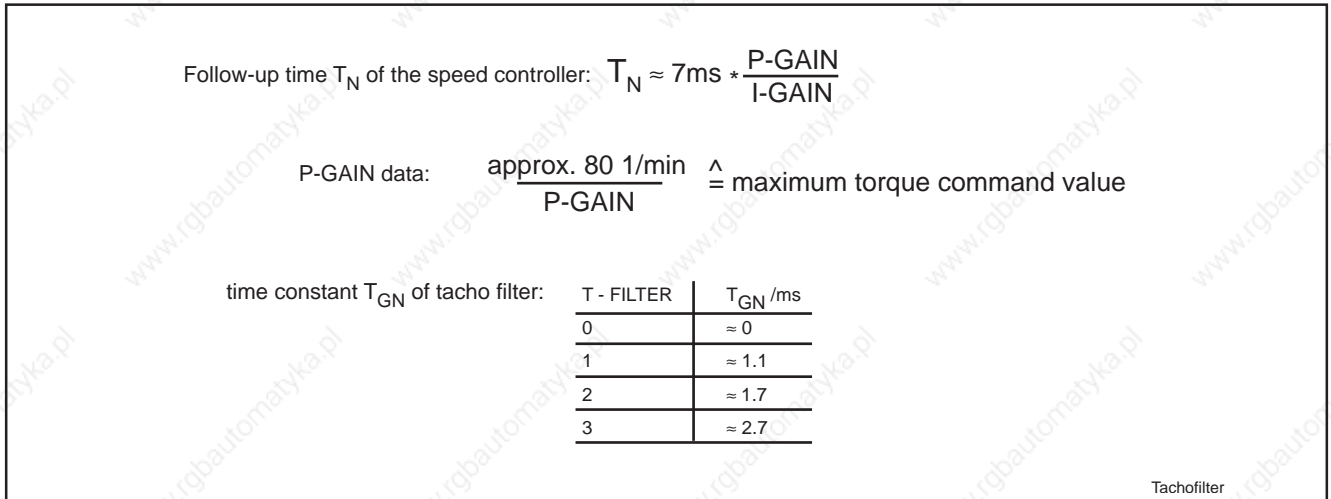

Figure 49: Data of the speed controller and tachometer filter

**Note:**

The values given are guide values only. They vary by about 10% depending on the drive.

### 3.8 C-Axis Function

At low lathe speeds, the main spindle is used as a servo axis. Contours can be cut on the workpiece through interpolation with the X-axis.

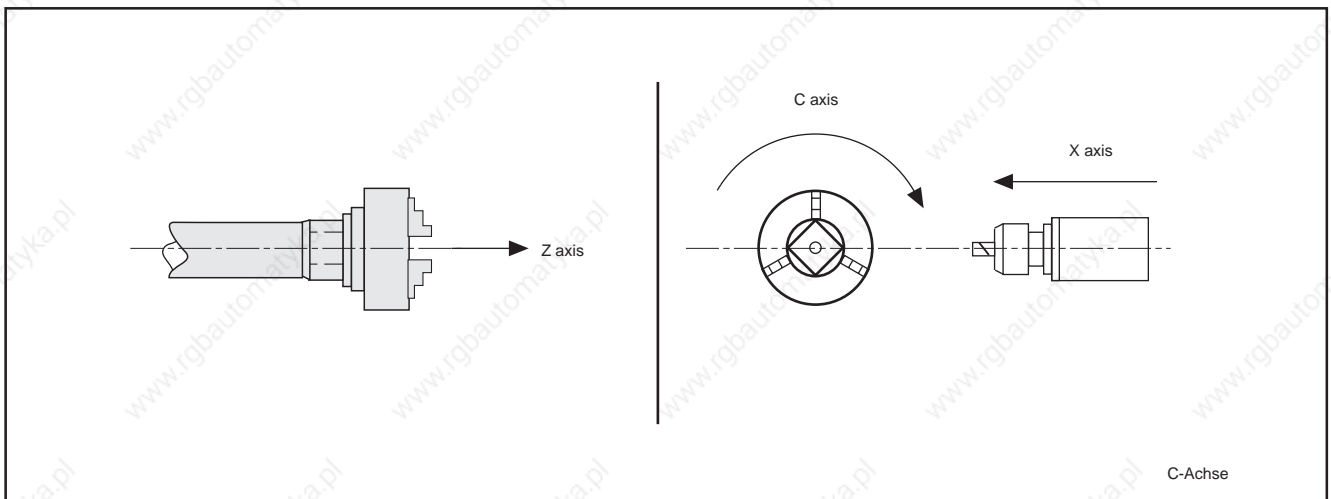

Figure 50: C-axis on turning machine

**Requirements**

The performance of the C-axis largely depends on the stiffness of the coupling between the motor and the spindle. Maximum stiffness is obtained with the 1MB frameless spindle motor.

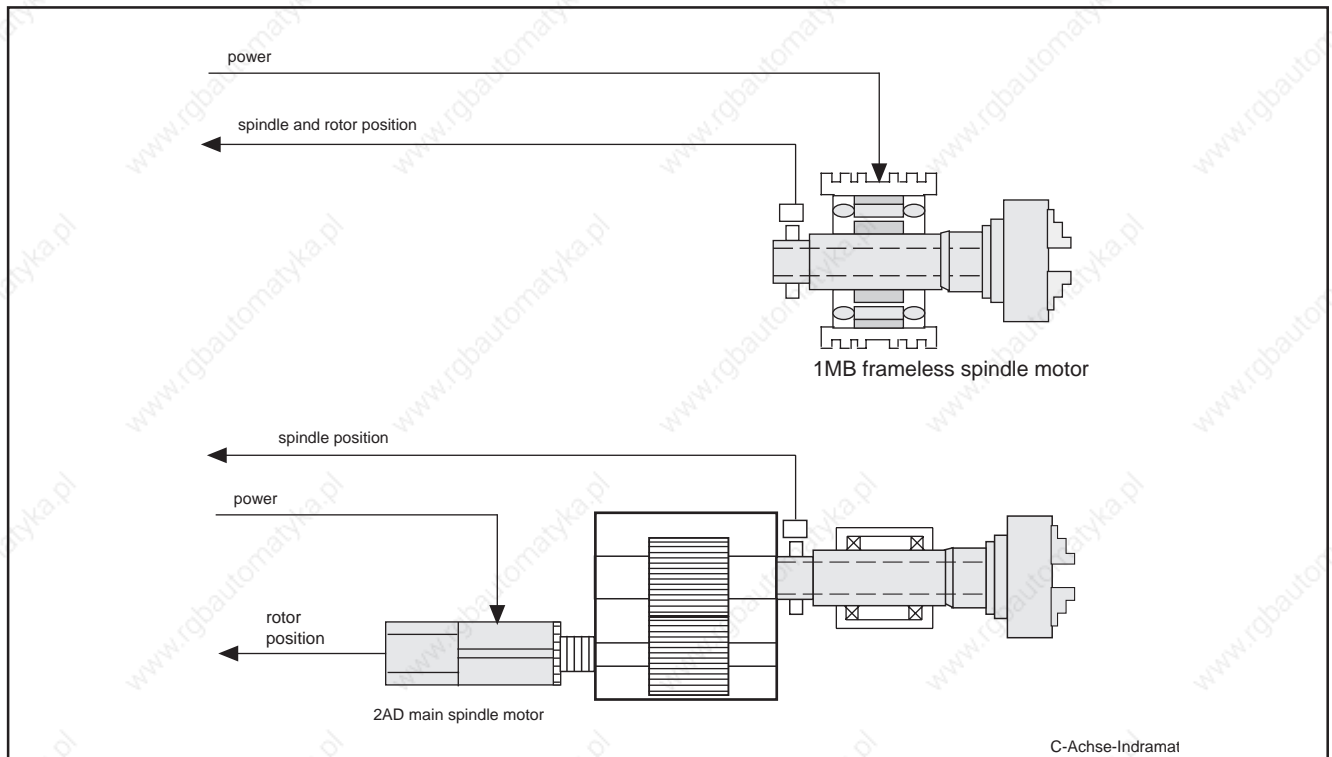

Figure 51: C-axis with Indramat main spindle drives

#### C-axis functions

In comparison to pure main spindle speed control, the drive requires the following for C-axis applications.

- higher rotational stiffness,
- finer resolution of command value input voltage and
- a second command value input, depending on the type of controller.

The following functions are available:

- changeover to a parameter record that is specially optimized to high rotational speed stiffness,
- changeover to fine resolution command value voltage and
- changeover to second command value input with function parameters.

Prerequisites:

- high-resolution motor feedback (on 2AD motor - type code field "motor feedback" = 3, 1MB motor with Indramat high-resolution encoder)
- direct measuring system on spindle (with incremental encoder or Indramat high-resolution encoder)

#### Note:

When the Indramat high-resolution encoder is used, the additional "incremental encoder output" interface is required on the control unit. This provides the NC controller with incremental encoder-compatible signals with adjustable number of encoder lines.

### 3. Controller Functions

#### Conversion of functions

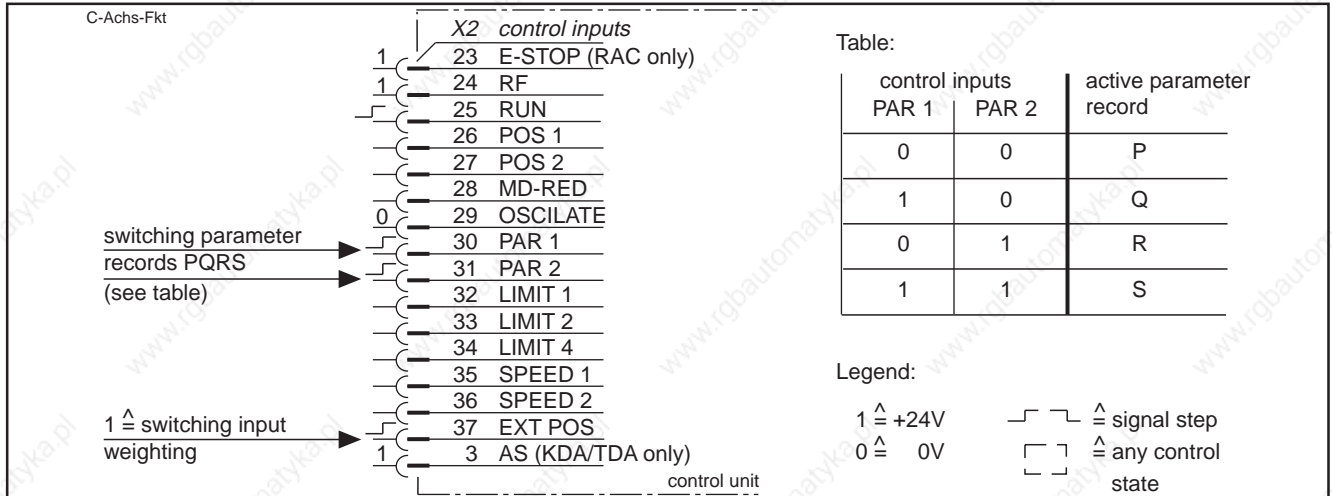

Figure 52: Controller inputs for C-axis functions

Parameter	Designation	Function	Value range or value
A01	MAXRPM	maximum motor speed	1.....24000 ( 1/min )
A02	CMD VOLT	analogue voltage value	6.0.....10.0 ( V )
S R Q P15	P-MAXRPM	motor speed for additional input weighting (low speeds)	1.....24000 ( 1/min )
S R Q P16	PQ-FUNCT	analogue input switching with input switching	< 1 >
A11	ENCODER 2	only with option "incremental encoder output":	- high-resolution INDRAMAT encoder: 128 mm ø < 3 > - high-resolution INDRAMAT-encoder: 256 mm ø < 4 >

Parameter protocol! Para-C-Achse

Figure 53: Parameter for C-axis functions

#### Note:

If the EXT POS control input is set to 0, then the weighting CMDVOLT = MAXRPM applies (for high speeds).

If the EXT POS control input is set to 1, then the weighting CMDVOLT = P-MAXRPM applies (for lower speeds).

*Weighting conversion speed command value*

Changeover to the second differential input (parameter PQ FUNCT) can be obtained with the weighting changeover (EXT POS = 1).

### 3.9 Power and Torque Limits

Torque and power limiting protects the workpiece, tool and machine from damage in some cases.

Indramat main spindle drives provide a choice between:

- limiting peak torque without limiting peak power of the drive or
- limiting peak torque and peak power of the drive at the same time.

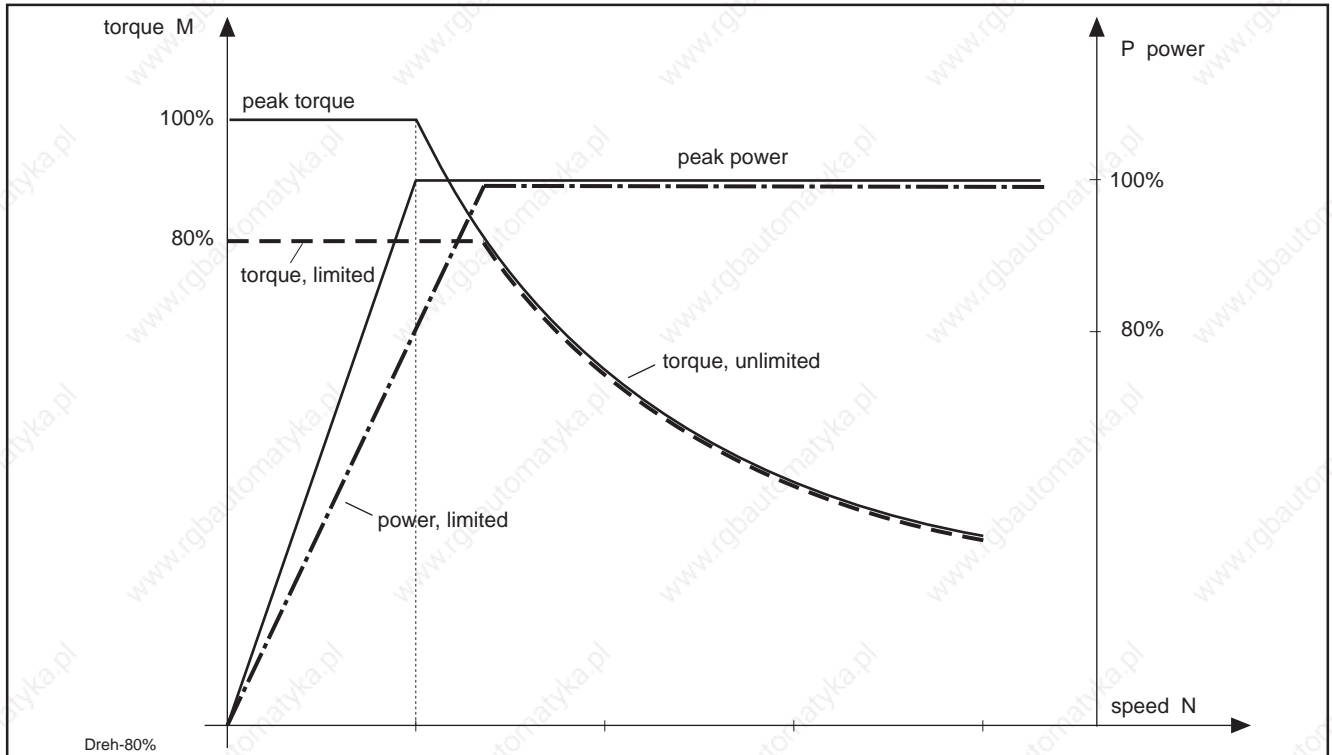

Figure 54: Example showing the torque limited to 80% of the peak value without limiting the peak power

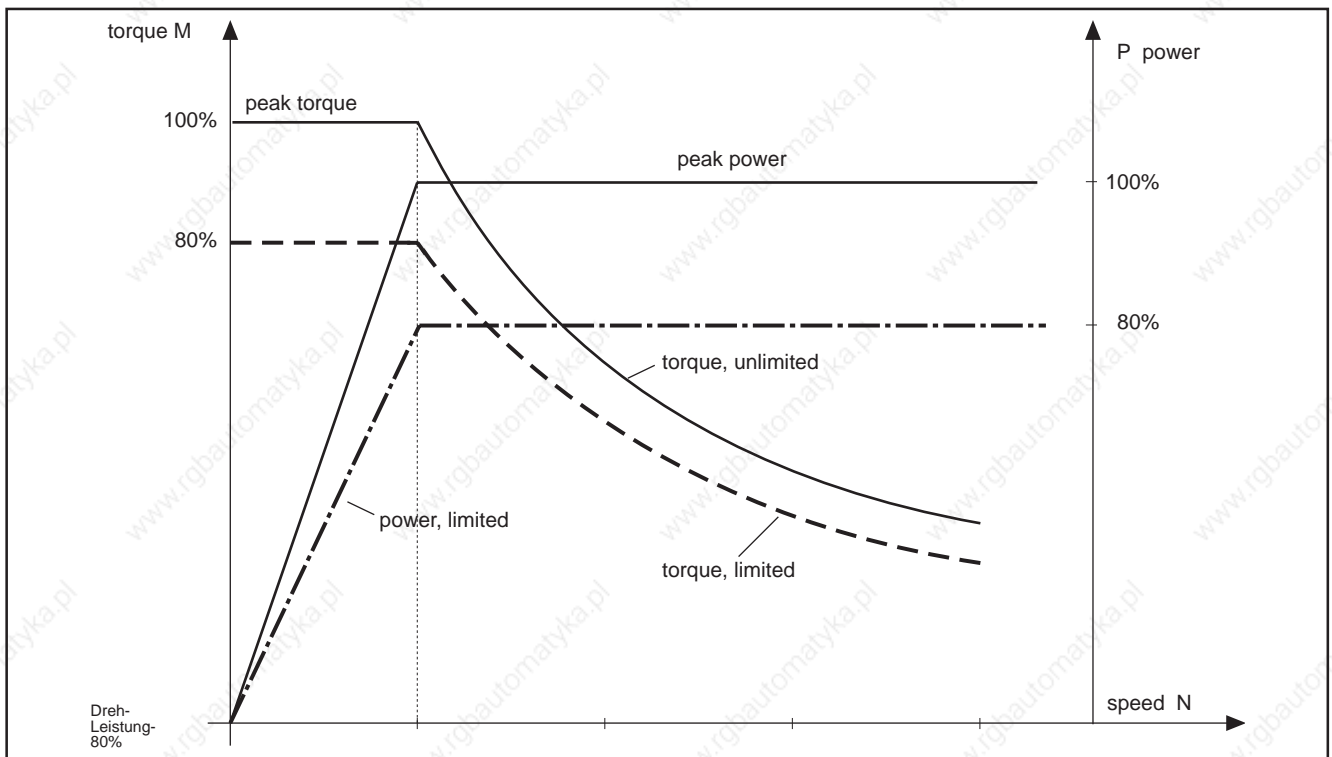

Figure 55: Example of torque and power limited to 80% of peak value

*Limiting with parameter or analogue voltage*

In the simplest case, the amount of limiting is stored as a per cent in the switchable parameter records. One value is possible per parameter record.

If several limiting values are required within the parameter records, then the limiting value can also be input as a voltage of the analogue input.

In both cases, limiting is activated via the MD-RED control input. To avoid speed dips, the drive monitors the utilization. If the utilization has reached 90% of the current possible maximum value, then the "90% LOAD" output switches from 1 to 0!

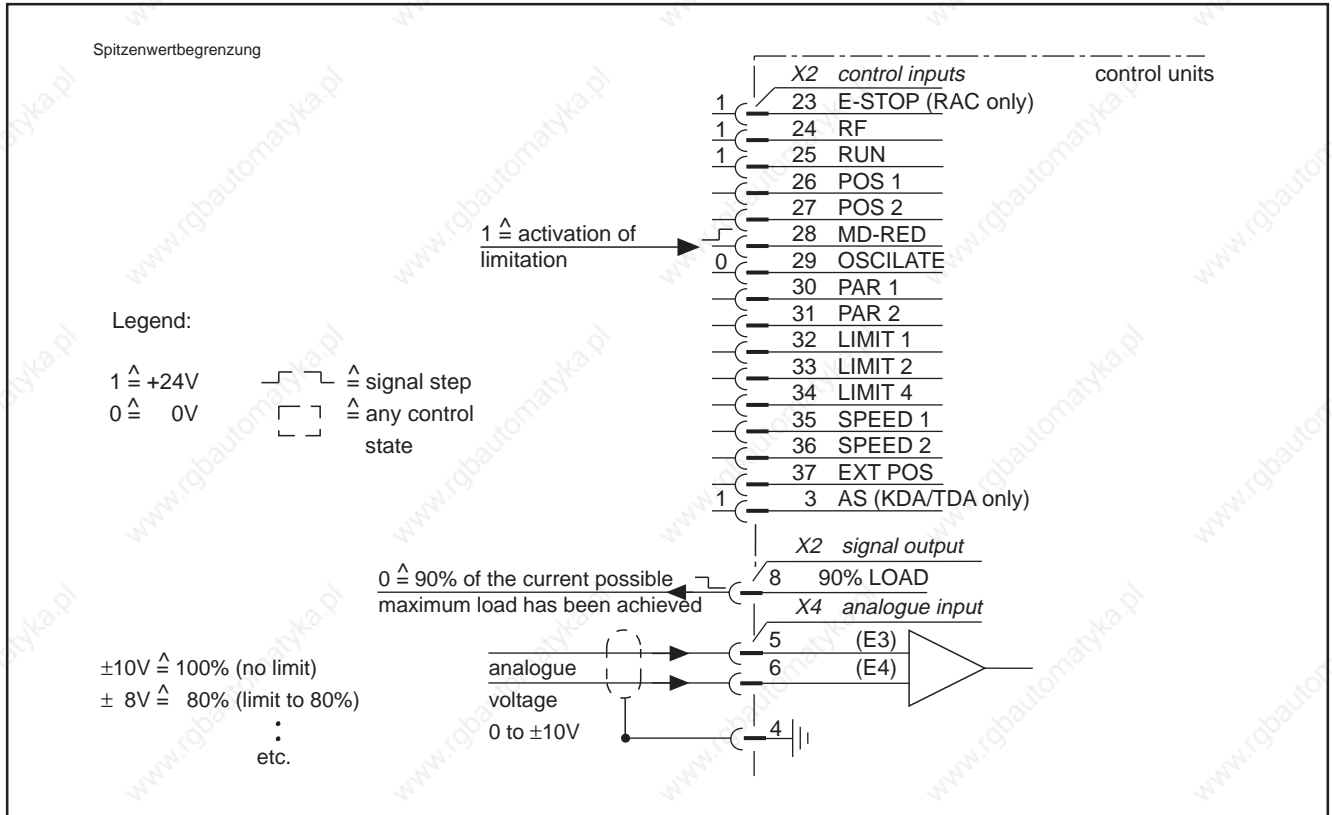

Figure 55: Control and analogue inputs, signal output for peak value limiting

Parameter	Designation	Function	Value range or value
A05	FUNCT 1	torque and power limits if control input MD-RED is at 1	< 0 >
		only torque limit with control input MD-RED at 1	< 1 >
SRQ P6	MD-RED	per cent value of peak torque	1....99 (%)
SRQ P16	PQ-FUNCT	torque limit via voltage at analogue input X4 ( E3/E4 ): ±10V = 100% = peak torque	< 32 >

Parameter protocol! Para-Spitzenwert

Figure 56: Parameter for peak value limiting

*Changeover capability of the limiting mode and values*

As the "MD-RED" and "PQ-FUNCT" parameters occur several times, both types of limiting can be used via relevant parameters or by switching parameter records, without interrupting the operation of the drive.

### 3.10 Drive Utilization Output

There is a risk of damage to tools, workpieces or the machine if cutting power is fully utilized.

To prevent damage, the main spindle drive controller has three simple ways for displaying and signalling the utilization:

- analogue output for visual display on a measuring instrument (analogue output M, see 3.1.0.1)
- 90% LOAD signal output (see 3.9)
- LOAD LIMIT signal output with adjustable signal threshold (see 3.10.2)

#### 3.10.1 Analogue output for drive utilization (analogue output M)

A simple visual indication of the drive utilization can be set up at analogue output M with a voltage value of between 0 and +10V.

The voltage value at analogue output M (0 to 10 V) corresponds to

- either the percentage torque utilization of the drive,
- a torque utilization related to the machining,
- a power level related to the machining and
- a torque value.

#### A) Percentage torque utilization

- Basic state of the analogue output M (for default parameter values).

The voltage value refers to the speed-dependent, available maximum torque (100% value). This shows how near the utilization approaches the 100% value.

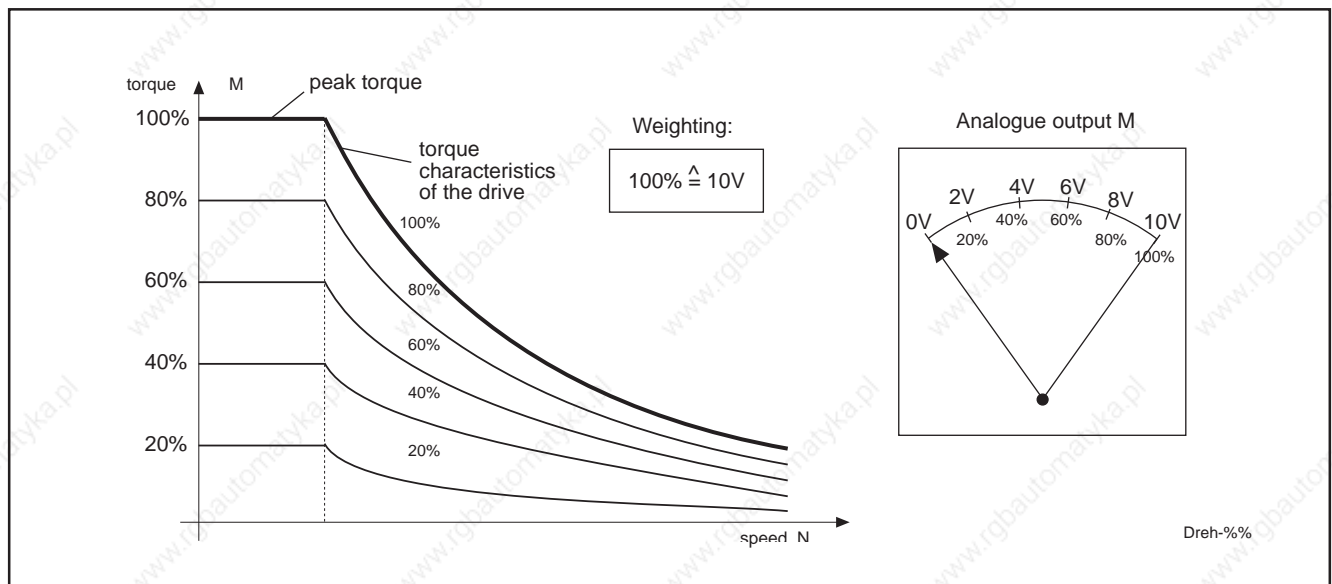

Figure 58: Display of percentage torque utilization

**B) Torque utilization related to the machining**

- The voltage value relates to the value in parameter LOAD LIM (PQRS 19).
- LOAD LIM (PQRS 19) must be arranged via function parameter FUNCT2 (A06) = < 1 > as a % value.
- The value in parameter PQ-FUNCT (PQRS 16) must contain < 16 >!

The analogue output M now indicates how near the drive approaches a set percentage torque utilization threshold. Four machining-dependent thresholds can be set by the fourfold LOAD LIM parameters.

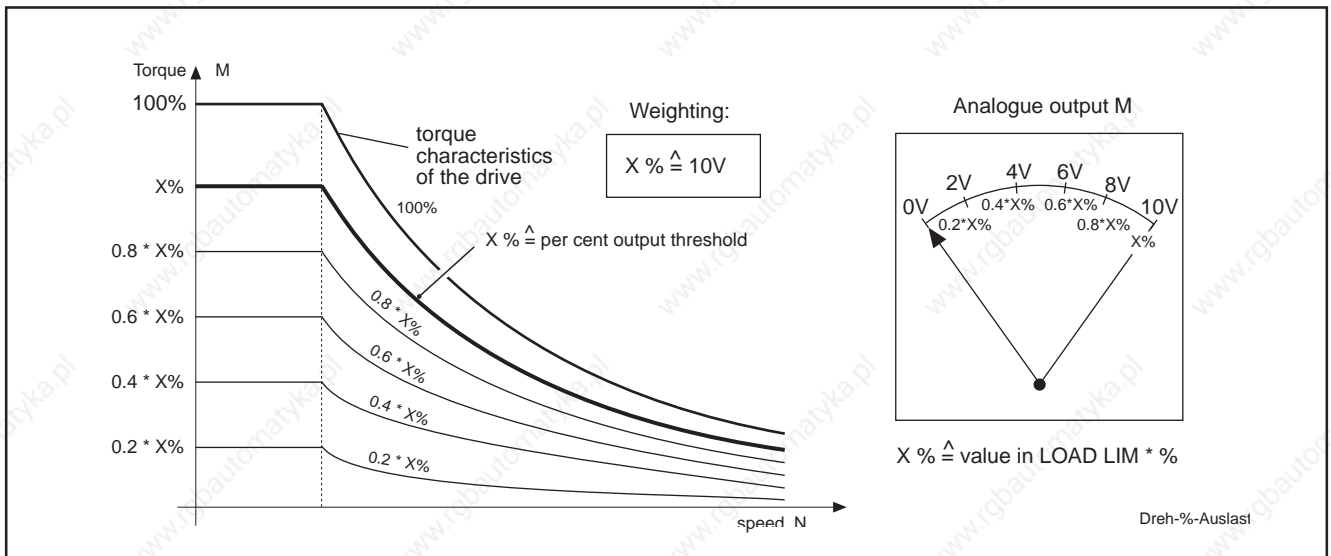

Figure 59: Display of torque utilization in relation to a set percentage utilization threshold

**C) Power level related to the machining**

- The voltage value relates to the value in parameter LOAD LIM (PQRS 19).
- LOAD LIM (PQRS 19) is arranged as the power value in the basic state (default parameter value FUNCT 2 (A06) = < 0 > ).
- The value in parameter PQ-FUNCT (PQRS 16) must contain < 16 >!

The analogue output M now indicates how near the drive approaches a set power threshold. Four machining-dependent thresholds can be set by the fourfold LOAD LIM parameters.

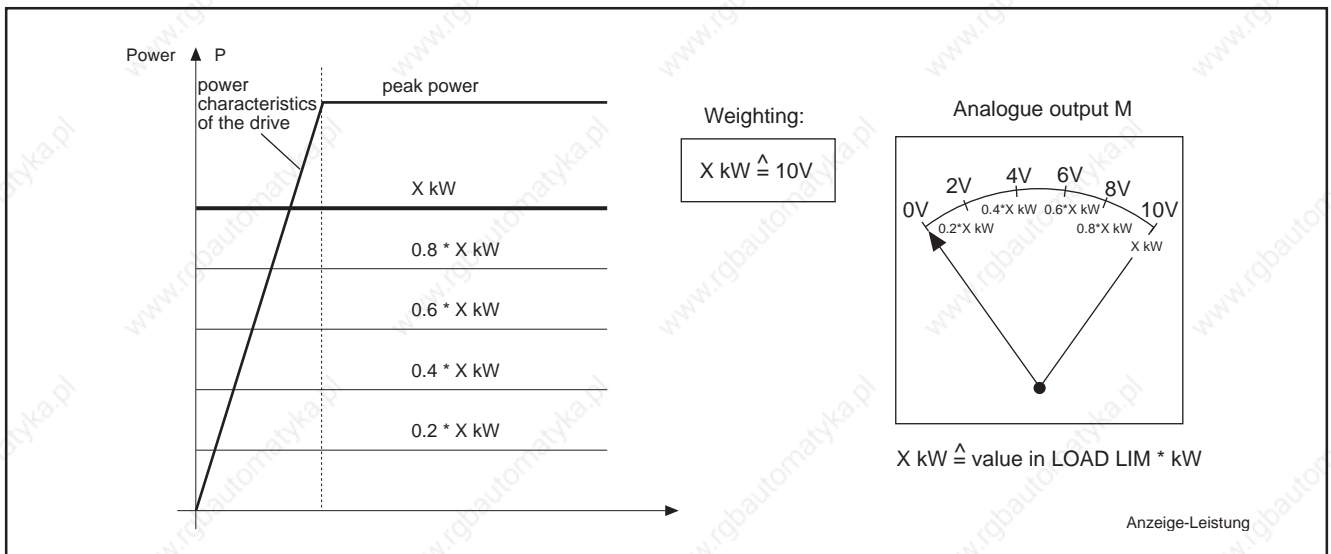

Figure 60: Display of power in relation to a set percentage power threshold

D) Torque value

- The voltage value relates to the value in parameter LOAD LIM (PQRS 19).
- The value in function parameter FUNCT2 (A06) must contain < 512 >!
- Parameter PQ-FUNCT (PQRS 16) has no significance in this case!

The analogue output M now indicates how near the load approaches a machining-dependent torque limit. Four machining-dependent torque thresholds can be set by the fourfold LOAD LIM parameters.

The torque value indicated is calculated from the DC bus power and the present motor speed.

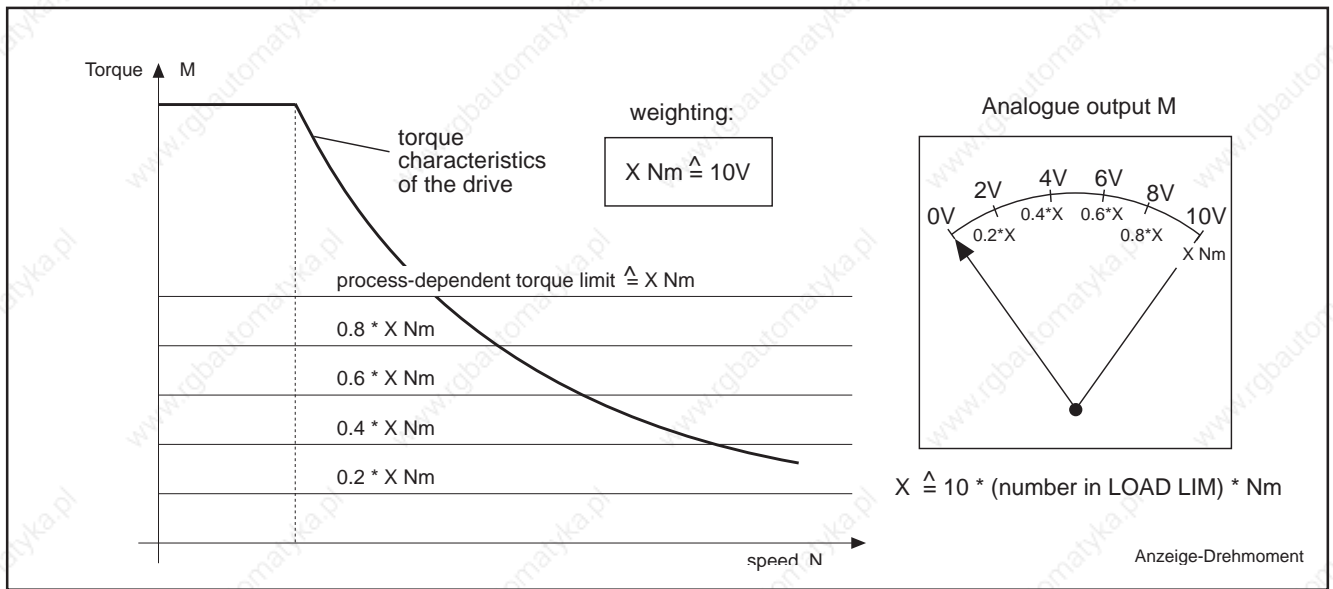

Figure 61: Torque value display

General data on the functions of the analogue output M

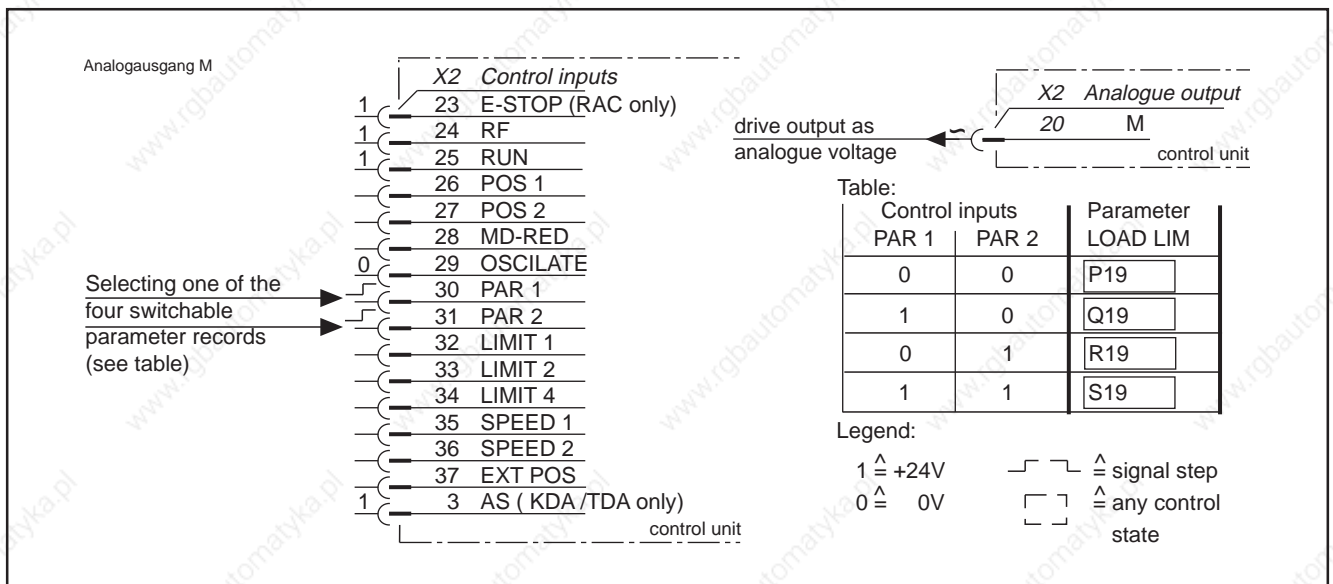

Figure 62: Control inputs and analogue output M

### 3. Controller Functions

Parameter	Designation	Function	Value range or value
SRQ P16	PQ-FUNCT	M output indicates load in per cent +10V = 100%	< 0 >
		M output indicates voltage +10V as relates to value in LOAD LIM, (kW or %) as specified in A06	< 16 >
SRQ P19	LOAD LIM	torque or power output threshold, depends on A06	0...99 ( % or kW )
A06	FUNCT2	Parameter LOAD LIM is output-related, value in kW	< 0 >
		Parameter LOAD LIM is torque-related, value in %	< 1 >
		M output indicates torque, +10V = 10 * (number in LOAD LIM) * Nm	< 512 >

 Parameter protocol ! Para-Analog M

Figure 63: Parameter for analogue output M

**Note:**

Analogue output M is designed to monitor static drive utilization. The voltage that it delivers is smoothed to suppress high-frequency variations in drive utilization. This produces a clearer display.

When the torque value is output at analogue output M, the percent drive utilization that is otherwise output at this point appears at analogue N.

If parameter LOAD LIMIT (PQRS 19) is used as a torque threshold, power threshold or as a weighting factor for torque output, then the LOAD LIMIT signal output is also active for this value.

### 3.10.2 Signal output with adjustable threshold for drive utilization (LOAD LIMIT)

The signal threshold for drive utilization is fully adjustable. It is included in each of the switchable parameter records PQRS and can be arranged as torque utilization or power signal threshold.

If the drive utilization reaches the signal threshold of the active parameter record, then the LOAD LIMIT signal output is active.

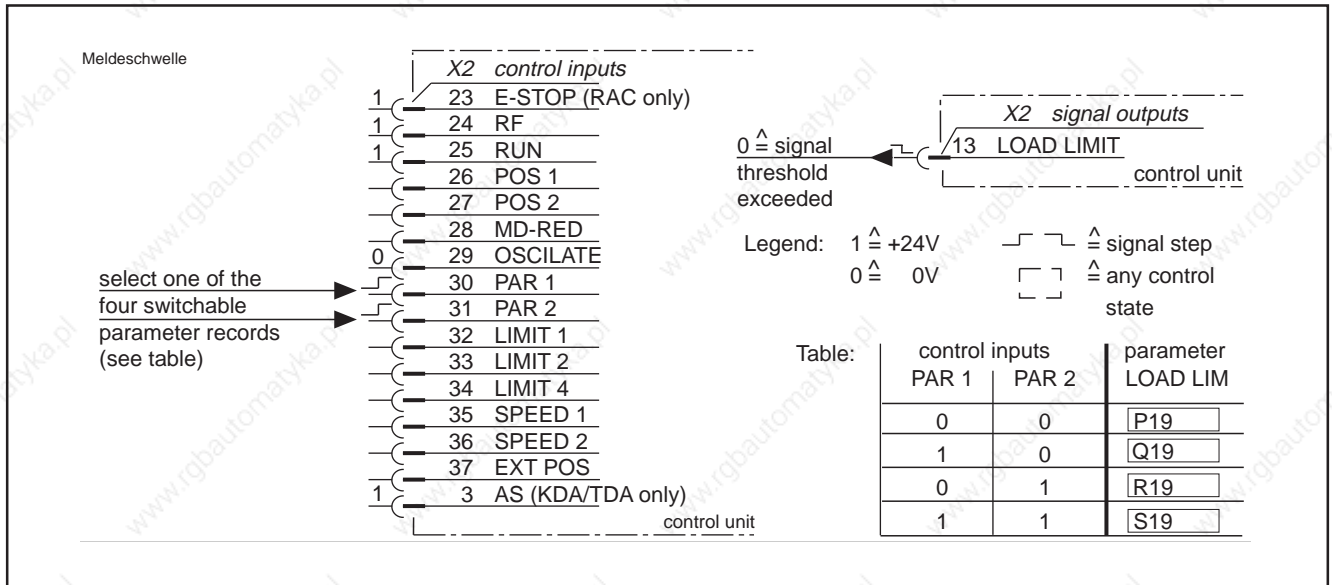

Figure 64: Control inputs and signal output for adjustable signal threshold

Parameter	Designation	Function	Value range or value
S R Q P19	LOAD LIM	signal limit for output load	1 to 99 (% or kW)
A06	FUNCT 2	signal limit is power-related, value in LOAD LIM is kW	< 0 >
		signal limit is torque-related, the value in LOAD LIM is a % of peak torque	< 1 >

Parameter protocol ! Para-Meldeschwelle

Figure 65: Parameter for adjustable signal threshold

### 3.11 Temperature Pre-Warning

Due to the overload capacity of the main drives, load cycles can be used which need more than the continuous power from the drive for short periods. Choice of correct drive size ensures that the temperature of motor and controller is always in the permissible temperature range. If, though, the cooling system of motor or controller is not operating correctly (dirt, etc.), there is a risk of damage to the drive from overheating.

*Protection against overheating*

INDRAMAT main spindle drives are protected against overheating:

- If the motor or controller temperature approaches the limit of the temperature range, this is signalled to the controller via the TEMPWARN alarm output. If the alarm is caused by the motor temperature, the message MOTWARN appears in the display. KKWARN appears if it is caused by the controller.
- The drive is switched off automatically if the load is not removed and the temperature continues to rise.

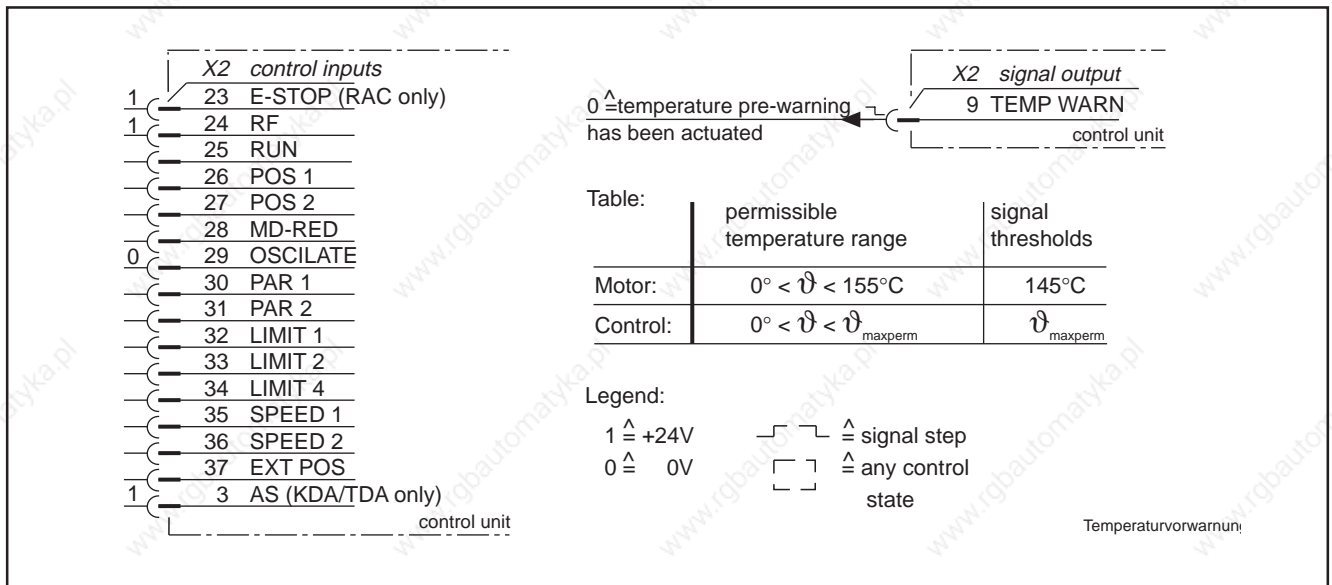

Figure 66: Control inputs and signal output for temperature pre-warning

*Heatsink pre-warning*

If KKWARN appears in the display, the drive switches off after 30 seconds and KKTEMP appears in the display.



**Drive torque is immediately limited to 50% when KKWARN appears!**

*Motor temperature pre-warning*

If MOTWARN (winding temperature 145°C) appears and the temperature continues to rise, the drive switches off at a windings temperature of 155°C and MOTTEMP then appears in the display.

*Wire break monitoring*

With no temperature sensor connected, the TEMPWARN output is also active after ten minutes with at least 10% loading. NO TEMP appears in the display and the drive switches off.

*Possible error messages in the display*

- NO TEMP
- MOT WARN
- KK WARN
- MOT TEMP
- KK TEMP

### 3.12 Maximum Spindle Speed

In machine tools, various tools or chucking devices with different permissible maximum speeds, can be used on the main spindle.

INDRAMAT main spindle drives enable the spindle speed to be monitored and limited to seven different, freely-selectable maximum speeds.

#### Function conversion

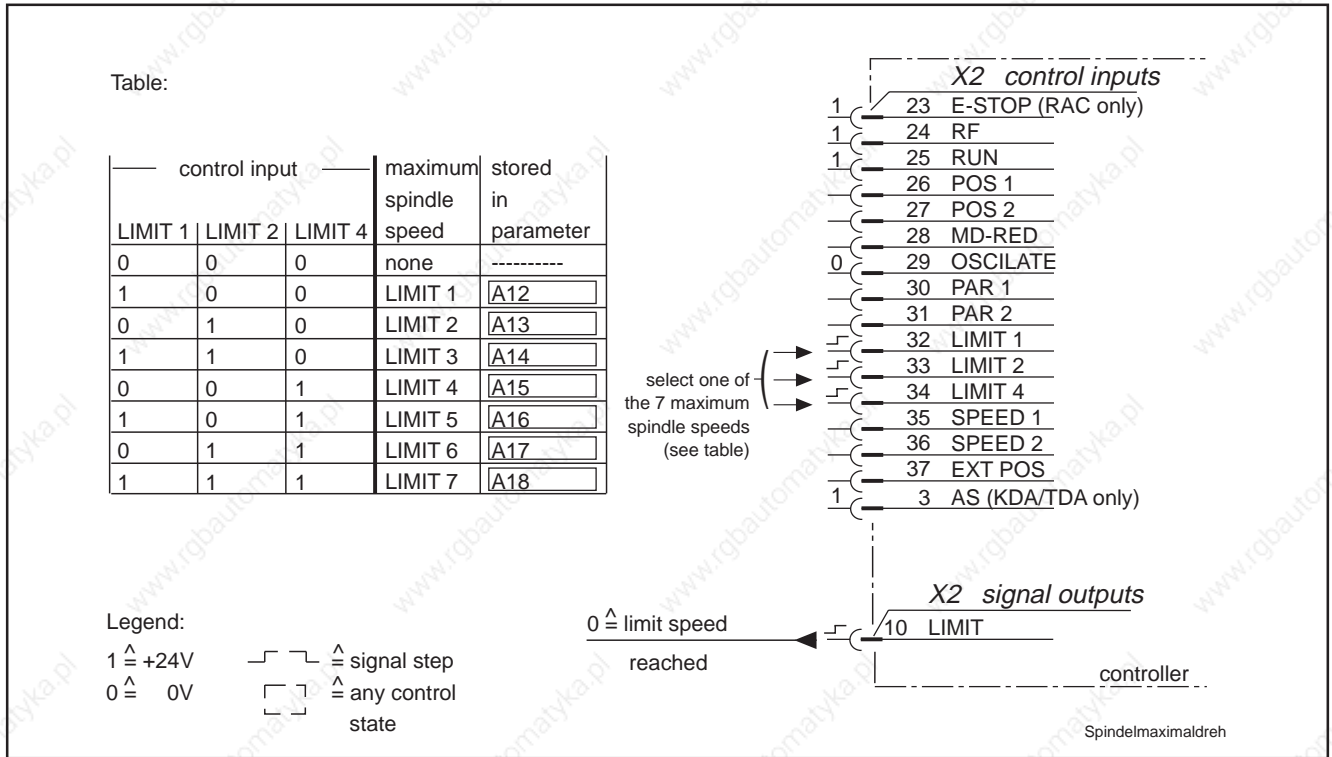

Figure 67: Control inputs and signal output for maximum spindle speed

Parameter	Designation	Function	Value range or value
A12	LIMIT 1	spindle maximum speed 1	1.....24000 (1/min)
A13	LIMIT 2	spindle maximum speed 2	1.....24000 (1/min)
A14	LIMIT 3	spindle maximum speed 3	1.....24000 (1/min)
A15	LIMIT 4	spindle maximum speed 4	1.....24000 (1/min)
A16	LIMIT 5	spindle maximum speed 5	1.....24000 (1/min)
A17	LIMIT 6	spindle maximum speed 6	1.....24000 (1/min)
A18	LIMIT 7	spindle maximum speed 7	1.....24000 (1/min)
SRQ P12	GEAR IN	gear ratio $i = \frac{N_1}{N_2}$	$N_1$ 1.....999
SRQ P13	GEAR OUT		$N_2$ 1.....999

Parameter protocol !

Para-Spindel.mox

Figure 69: Parameter for maximum spindle speed

**Acknowledging maximum speeds** The spindle speed is limited to the amount ( $\pm$ ) of the selected maximum speed, and, on reaching the limit speed, is also acknowledged via the LIMIT signal output.

**Condition for " $N_{actual} = N_{command}$ "** The controller calculates the limit speed of the motor associated with the limit speed of the spindle with the reduction ratio (GEAR IN/GEAR OUT). If the speed command value is excessively high, the message " $N_{actual} = N_{command}$ " (signal output N=CMD) does not appear.

### 3.13 Spindle Monitor

The spindle monitor detects any defective or dangerous condition when the machine is first started, if this is due to a malfunction in the mechanical transmission components.

The controller monitors breaks in the mechanical connection between the spindle and the spindle feedback. The controller also detects the absence of signals from the spindle feedback but when the motor is running.

Spindle monitoring requires a spindle feedback unit connected to the controller.

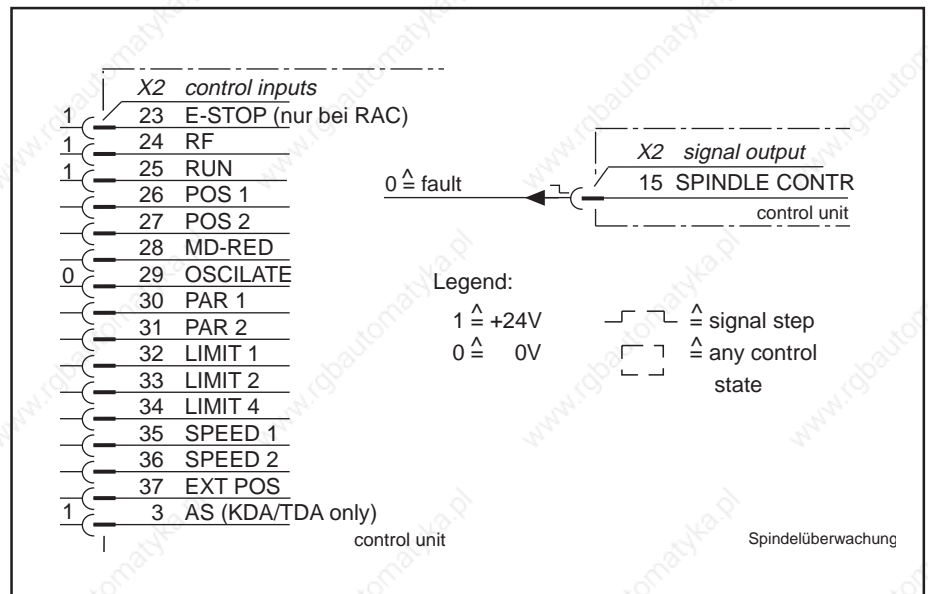

Figure 69: Control inputs and signal output for spindle monitor

**Note:**

For very slow spindle speeds (spindle coasting), the spindle monitor still signals the OK status.

Faults on the spindle encoder line can be detected as increments and the OK status is signalled despite the fact that the spindle is stationary (check function precisely during commissioning).

### 3.14 Switchable Parameter Records

The switchable parameter records enable the drive to automatically and rapidly match the various tasks of a flexible machine tool while the drive is in operating mode by

- matching to different speeds,
- providing functions for various operating processes,
- operating with position control loop parameters for spindle positioning,
- and with automatic speed change in a two-speed gearbox.

Indramat main spindle drives have six parameter records. Of these, two (the A and M parameters) are always active. In addition, one of the four switchable parameter records (P, Q, R or S) is always active.

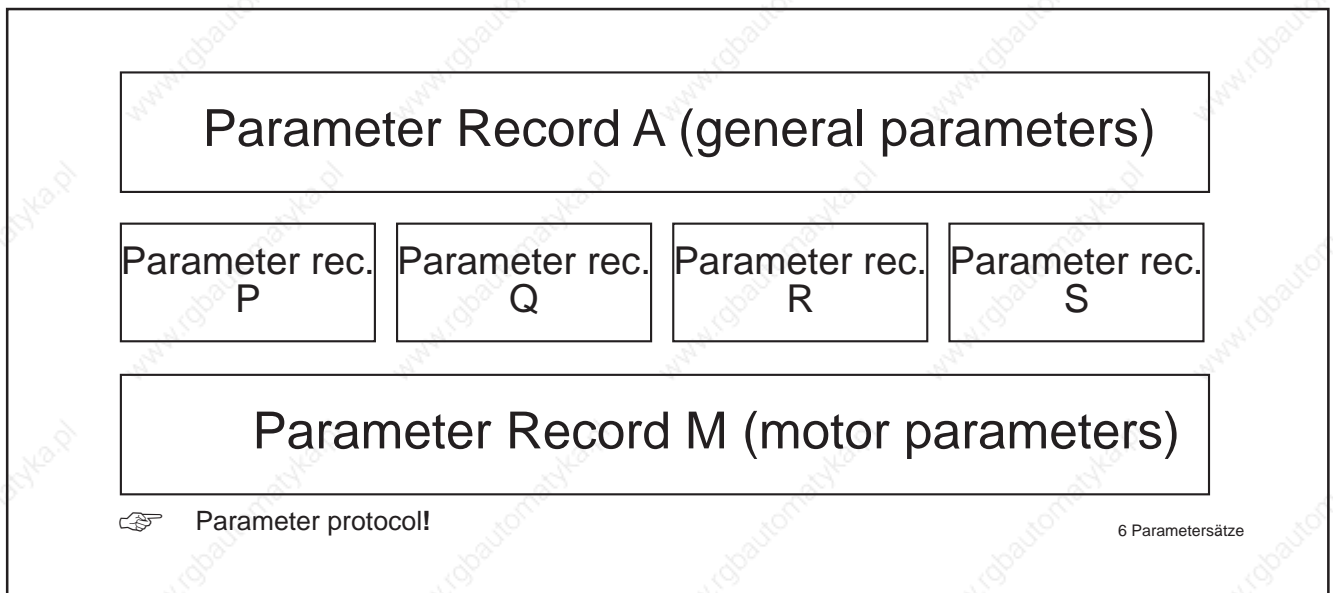

Figure 70: The six parameters records for Indramat spindle drives

#### Function conversion

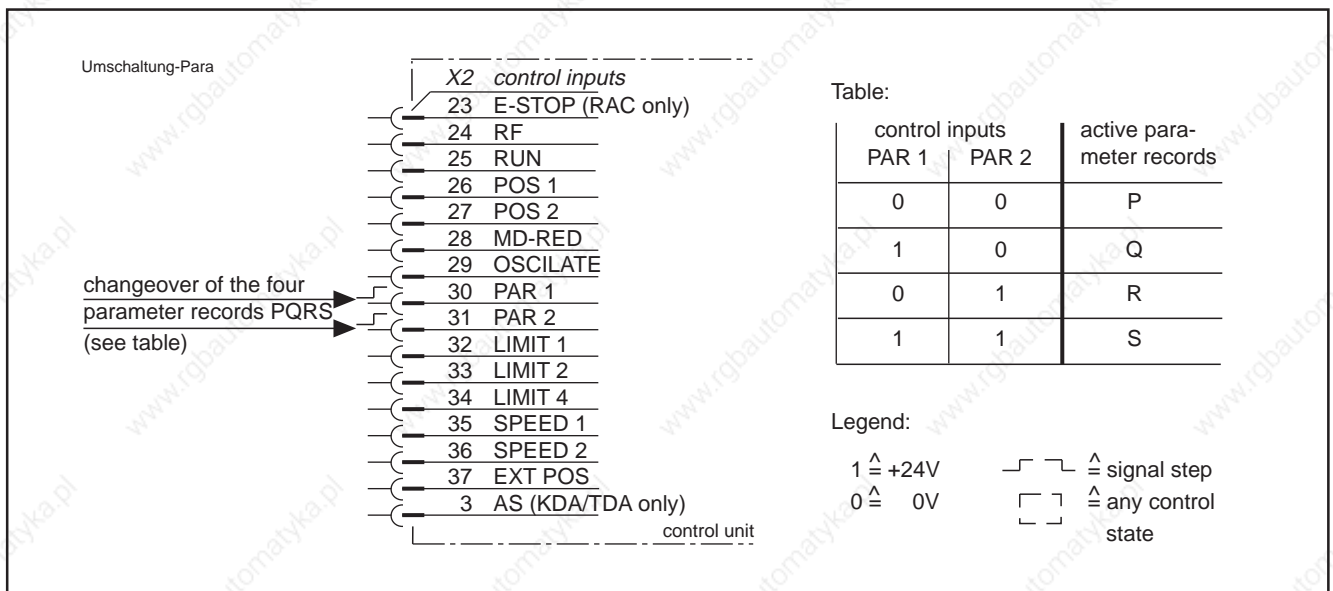

Figure 71: Control inputs for switching the parameter records

### 3. Controller Functions

Parameter name	Parameter record P	Parameter record Q	Parameter record R	Parameter record S	Function	Value range
RAMP 1	P01	Q01	R01	S01	3 speed command value ramps or command value smoothing	0.....999 (rad/s <sup>2</sup> )
RPM 1	P02	Q02	R02	S02		0.....24000 (1/min)
RAMP 2	P03	Q03	R03	S03		0.....999 (rad/s <sup>2</sup> )
RPM 2	P04	Q04	R04	S04		0.....24000 (1/min)
RAMP 3	P05	..	..	..		0.....999 (rad/s <sup>2</sup> )
MD-RED	P06	..	..	..	torque limit in %	1.....99
P-GAIN 1	P07	..	..	..	speed controller interconnect 1	0.....19.99
I-GAIN 1	P08	..	..	..		0.....9.99
GAIN-RPM	P08	..	..	..	changeover speed from P-I-GAIN 1 to 2	0.....9999 (1/min)
P-GAIN 2	P10	..	..	..	speed controller interconnect 2	0.....9.99
I-GAIN 2	P11	..	..	..		0.....9.999
GEAR IN	P12	..	..	..	gear ratio $i = \frac{N_1}{N_2}$	1.....999
GEAR OUT	P13	..	..	..		1.....999
G-CHANGE	P14	..	..	..	allocation of switchable gear stages	0.....2
P-MAX RPM	P15	..	..	..	add. weighting of command value voltage	1.....24000 (1/min)
PQ-FUNCT	P16	..	..	..	parameter record functions	0.....9999
POS GAIN	P17	..	..	..	gain factor of the position control loop	0.....99.9 (1/s)
POS RPM	P18	..	..	..	positioning speed	1.....9999 (1/min)
LOAD LIM	P19	..	..	..	output signal threshold	1.....99 (%.kW)
ALPHA	P20	..	..	..		0.....9.999
P-WINDOW	P21	Q21	R21	S21	tolerance window for positioning	0.....9.99 (°)

- only with incremental encoder output option IGS, type code field "additional interface" = I

IGS REF	P22	Q22	R22	S22	reference switch offset	0.....359.9 (°)
IGS OPEN	P23	Q23	R23	S23	acceptance angle of the reference switch	0.....359.9 (°)
IGS LINES	P24	Q24	R24	S24	resolution of the simul. encoder	1.....16383
IGS FUNCT	P25	Q25	R25	S25	functions with IGS	0.....999

☞ see section "incremental encoder output"

Para-Übersicht

Figure 72: Summary of switchable parameter records P, Q, R and S

**Switchable function parameters** When the drive is operating the parameter record functions PQ-FUNCT, the following is possible:

- changeover of analogue differential inputs (X4)
- indication of possible reversed direction of rotation of motor and spindle feedback or motor and spindle after a gear change
- changeover to stop drive without overshoot
- changeover of speed and torque controlled operations
- changeover of voltage at analogue output M from torque loading to LOAD LIM related voltage output
- changeover from torque limiting by parameter value to limiting by voltage at analogue differential input (X4)
- changeover to spindle positioning via spindle reference switch

### 3.15 Gear Change

Various gear reduction stages are used, according to the spindle speed, to obtain a wide speed range with constant power at the spindle. This requires automatic gear changes in modern machine tools.

For two reduction stages, the controller handles the automatic changeover; for more than two stages, the changeover is supported by the controller by speed oscillation (hunting).

#### 3.15.1 Automatic Gear Change via the Controller

Prerequisites:

- two auxiliary d.c. contactors (see Figure 75)
- two-stage gearbox with gear-change motor
- acknowledgement feedback for gear stages

Gear change is initiated by a change to a parameter record that is assigned to a stage that is not engaged.

#### Function conversion

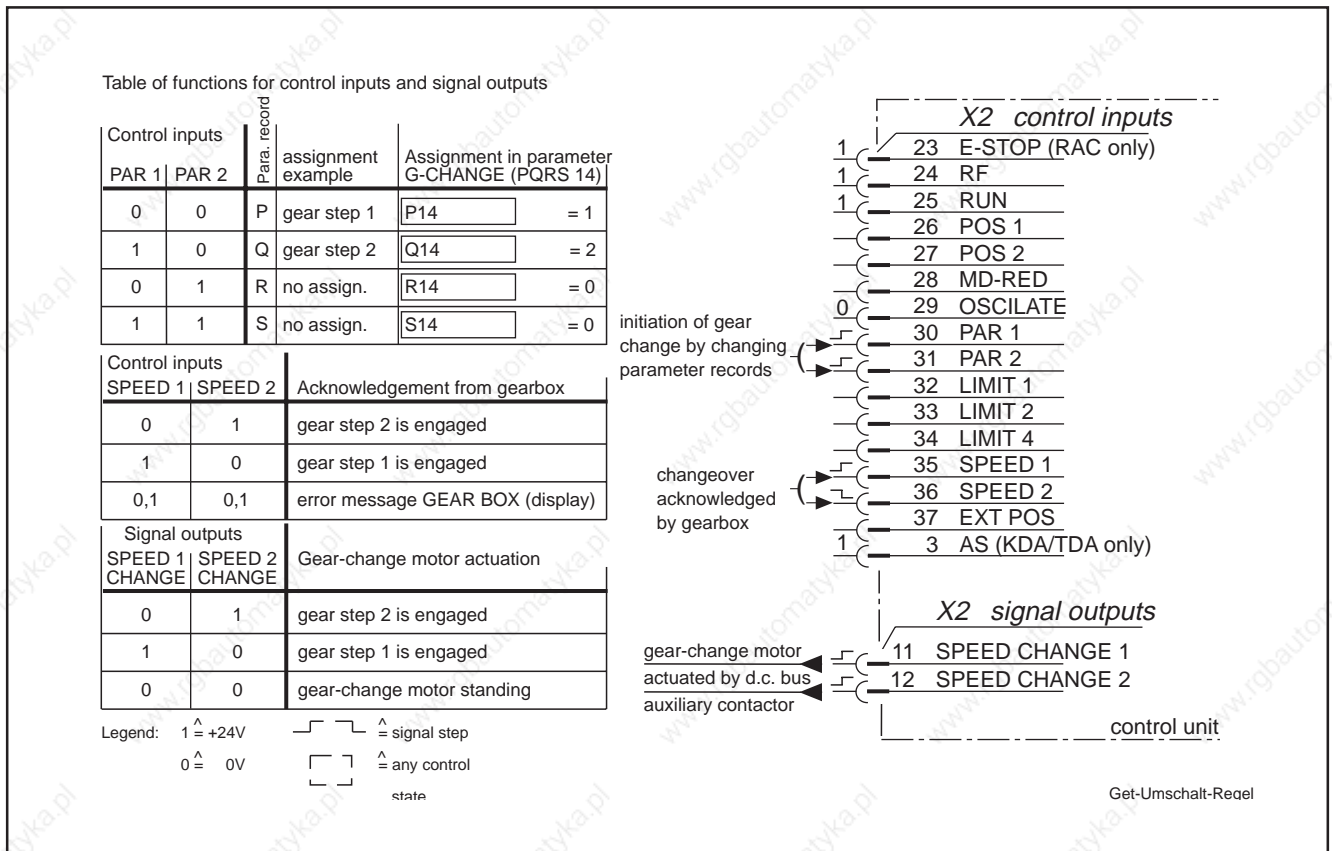



Figure 73: Control inputs and signal outputs for gear-change via the controller

Note:

The assignment of gear stages to parameter records P and Q is given as an example only. Any combination of parameter records P, Q, R and S is possible.

### 3. Controller Functions

Parameter	Designation	Function	Value range or value	
SRQ P14	G-CHANGE	allocation of parameter record to a gear stage	- none	< 0 >
			- stage 1	< 1 >
			- stage 2	< 2 >
A20	OSCI RPM	oscillation speed for gear changeover	1 to 200 (1/min)	

 Parameter protocol!

Para-Getriebeumschalt

Figure 74: Parameter for gear change via the controller

**Note:**

Gear stages 1 and 2 must each be assigned at least once to a parameter record by parameter values 1 and 2 in the G-CHANGE parameters.

When changing from a parameter record with assigned gear stage to a parameter record that is not assigned to any gear stage, the previous gear stage remains coupled.

*Gear stage dependent drive optimization*

The switchable parameter records enable the drive to be optimized according to the gear stages (see section 3.14).

### 3. Controller Functions

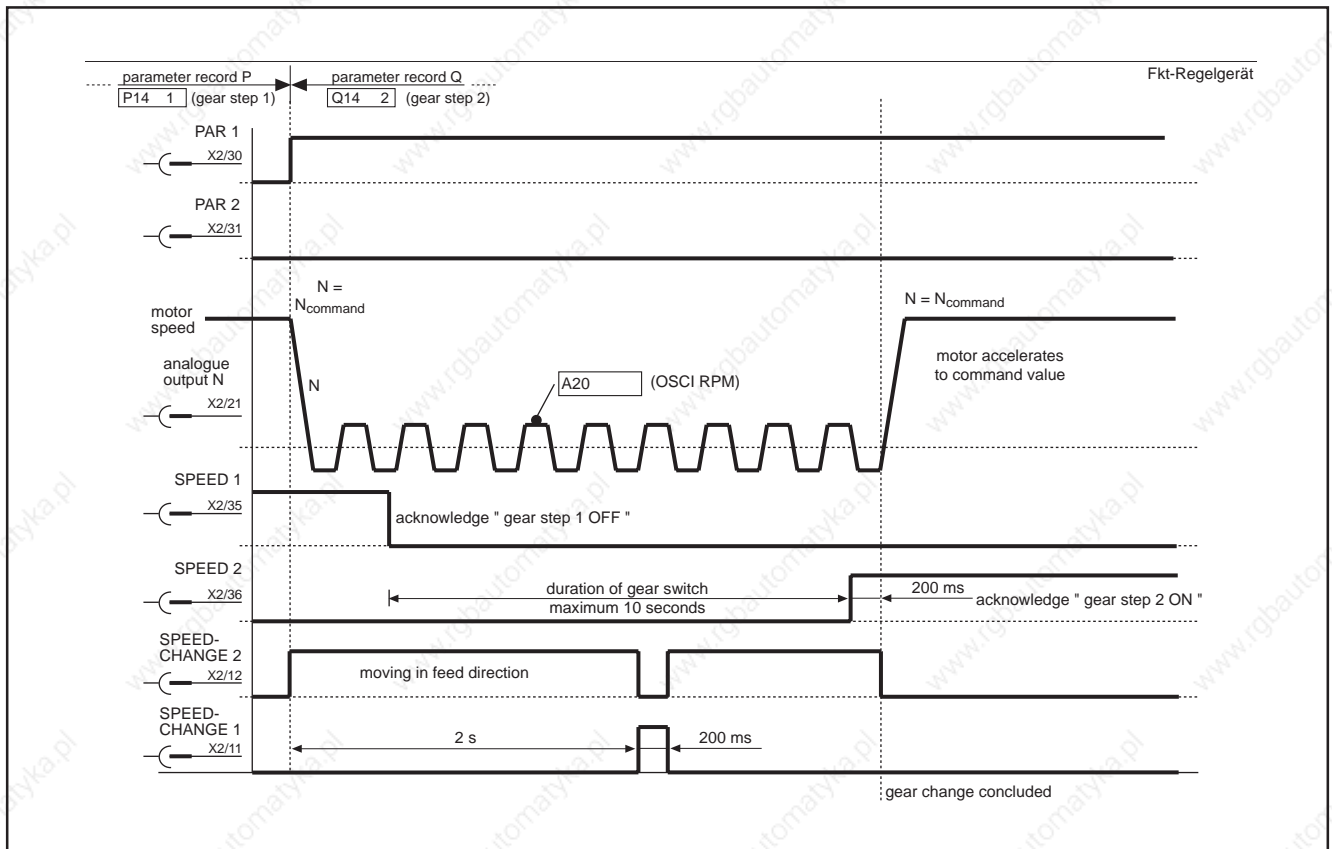

Figure 75: Sequence of operations - gear change via the controller

**Functional sequence** The gear change must be completed within ten seconds. If the gear stage to be engaged is not acknowledged via the corresponding control input SPEED 1 or SPEED 2, then the controller display shows GEARBOX and switches the drive and actuating motor off.

The indexing mechanism is displaced against the direction of engagement by the gear-change motor every two seconds for 200 ms so that the tooth-to-tooth points on the gear wheels can be released again. This can happen up to a maximum of five times during the ten-second interval.

During the gear-change process, the motor shaft hunts at the OSCI RPM speed and at a frequency of approximately 2.5 Hz. The message OSCILLATE appears in the display.

**Possible error messages on the display** GEAR BOX

### 3. Controller Functions

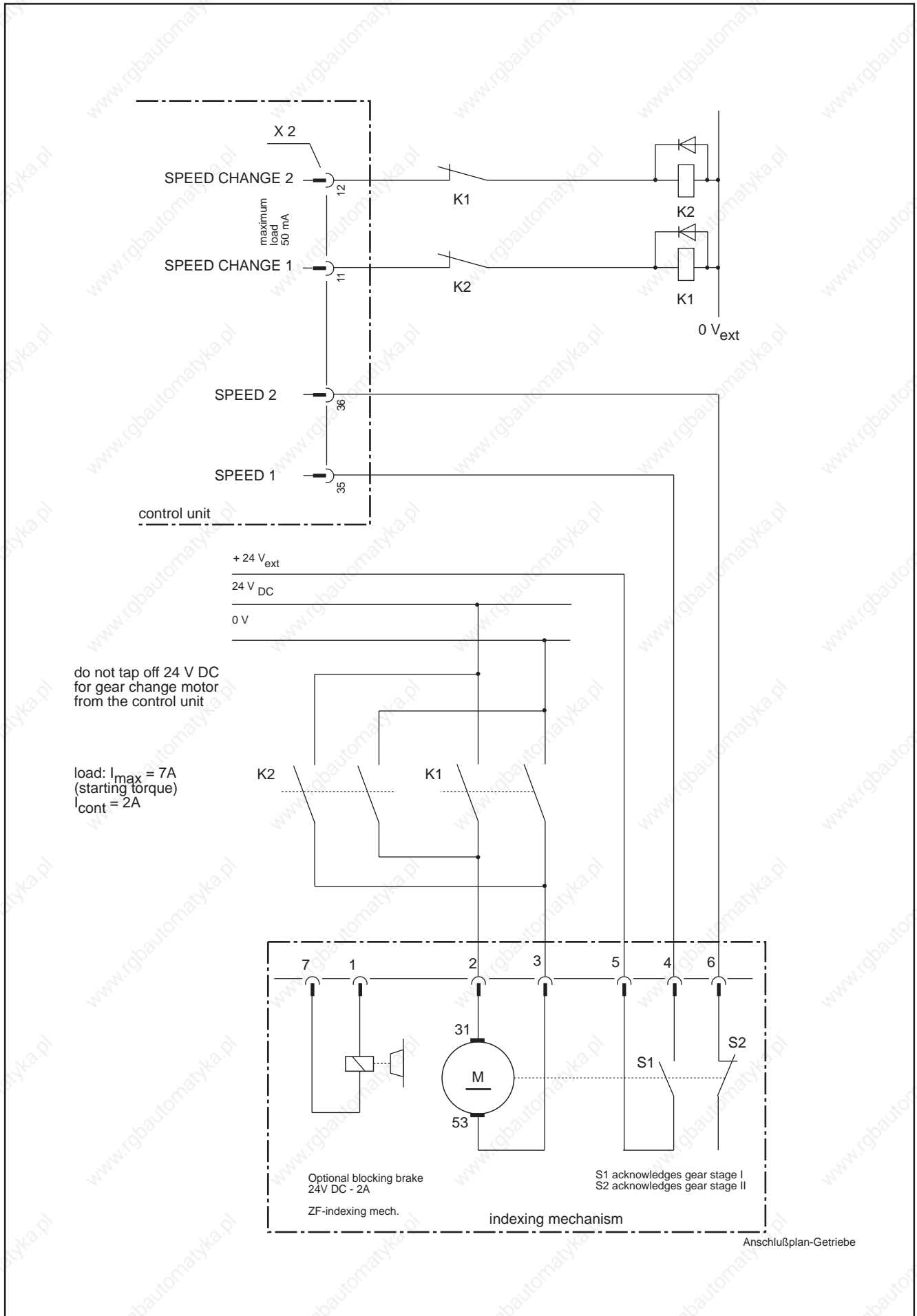

Figure 76: Connection diagram for gear change

### 3.15.2 Gear Change via an External Controller

*Gear stage dependent drive optimization*

The controller supports the gear change by the NC by:

- signalling the gear change "ready" stage ( $N < N_{min}$ )
- and oscillating the speed of the motor shaft.

The four parameter records enable the drive to be optimized according to the reduction stage.

#### Function conversion

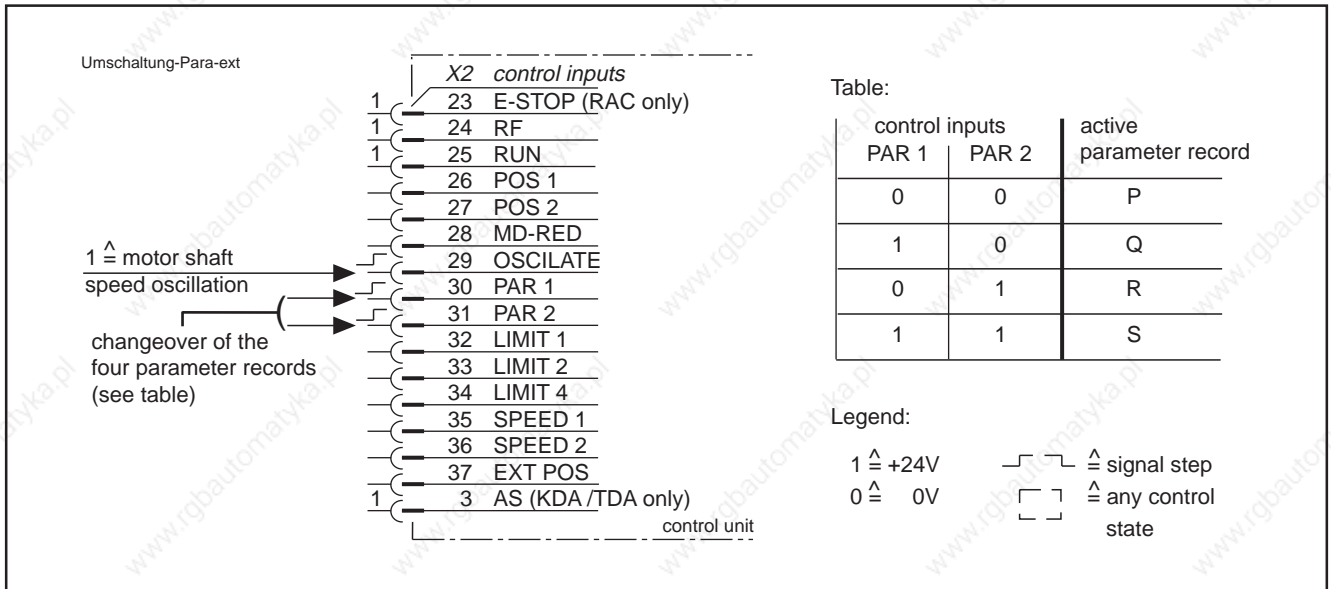

Figure 77: Control inputs for gear change via external controller

Parameter	Designation	Function	Value range or value
<input type="text" value="SRQ P14"/>	G-CHANGE	assignment of gear stage	- none 0
<input type="text" value="A20"/>	OSCI RPM	oscillation speed for gear changeover	1 to 200 (1/min)
<input type="text" value="A03"/>	MIN RPM	speed to initiate gear changeover via external control	1 to 999 (1/min)

Parameter protocol! Para-ext-Getriebeumschalt

Figure 78: Parameter for gear change via external controller

### 3. Controller Functions

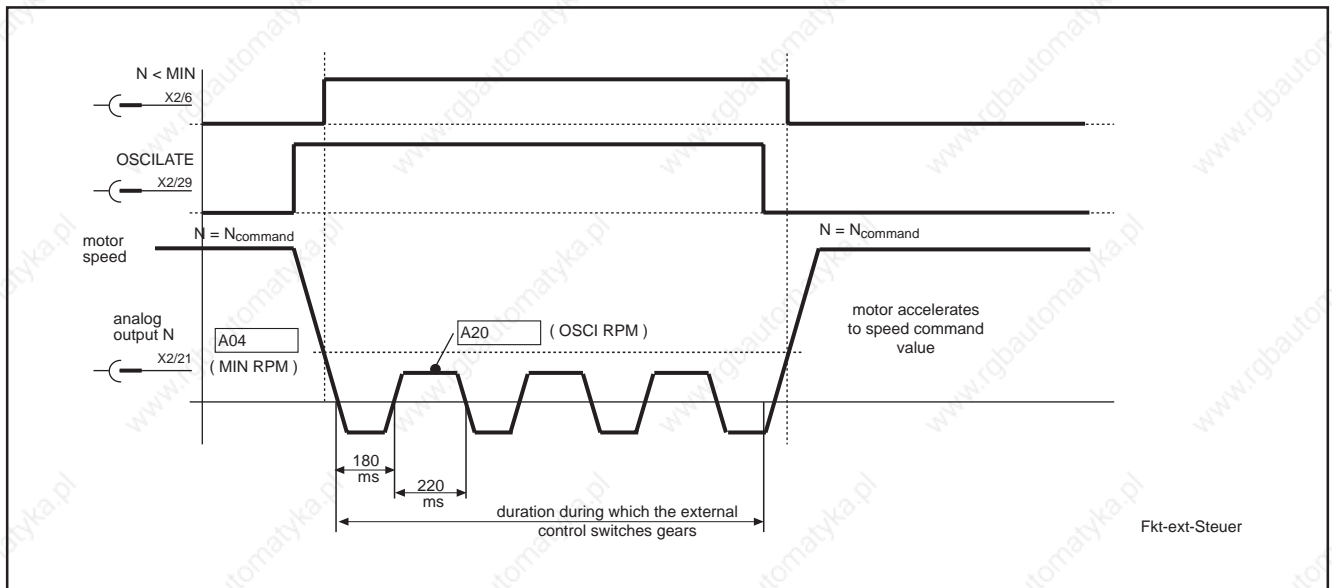

Figure 79: Sequence of operations - gear change via external controller with constant speed command value

#### Sequence of operations

The controller initiates the gear change by taking the OSCILLATE control input to 1. The drive then brakes at the set ramp and changes to oscillating speed at 2.5 Hz. The OSCILLATE message appears in the display. The oscillating speed is the value in parameter OSCI RPM.

The control unit tells the controller via the N<MIN signal output at what time point the speed of the motor permits a gear change. The signal output N<MIN gives a steady 1 if the value of the parameter MIN RPM is greater than that input by OSCI RPM.

Oscillation is asymmetrical, i.e., the motor shaft continues to turn during oscillation and can overcome tooth-tooth positions during engagement.

If the OSCILLATE control input is switched back to 0 after the gear change, the drive returns to the command value speed.

### 3.16 Two-Motor Changeover

It is conceivable in some installations that two drive tasks have to be performed at two different sites. If the two tasks never occur at the same time, then they can be performed with two motors connected to one control unit. The motors are selected by the controller.

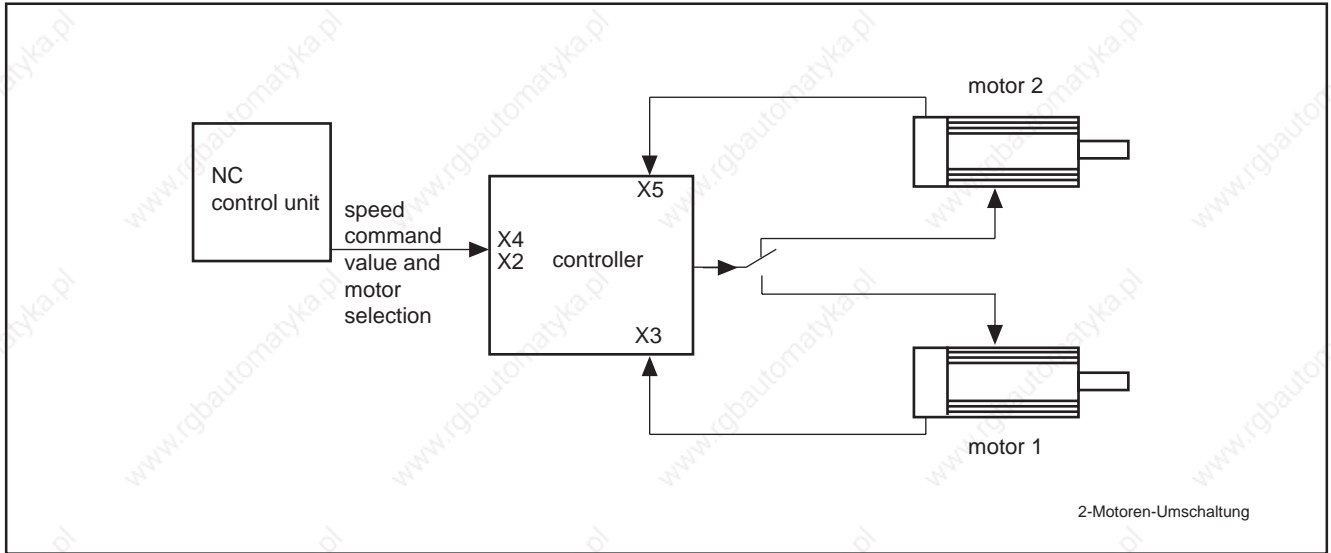

Figure 80: Schematic of two-motor changeover arrangement

Prerequisites:

- two motors of identical type
- a control unit with two encoder inputs (type code field "second encoder inputs"=P)
- two auxiliary d.c. contactors and two motor contactors (see Figure 83)

**Function conversion** Motor changeover is initiated by changing one of the parameter records that is assigned to the other motor.

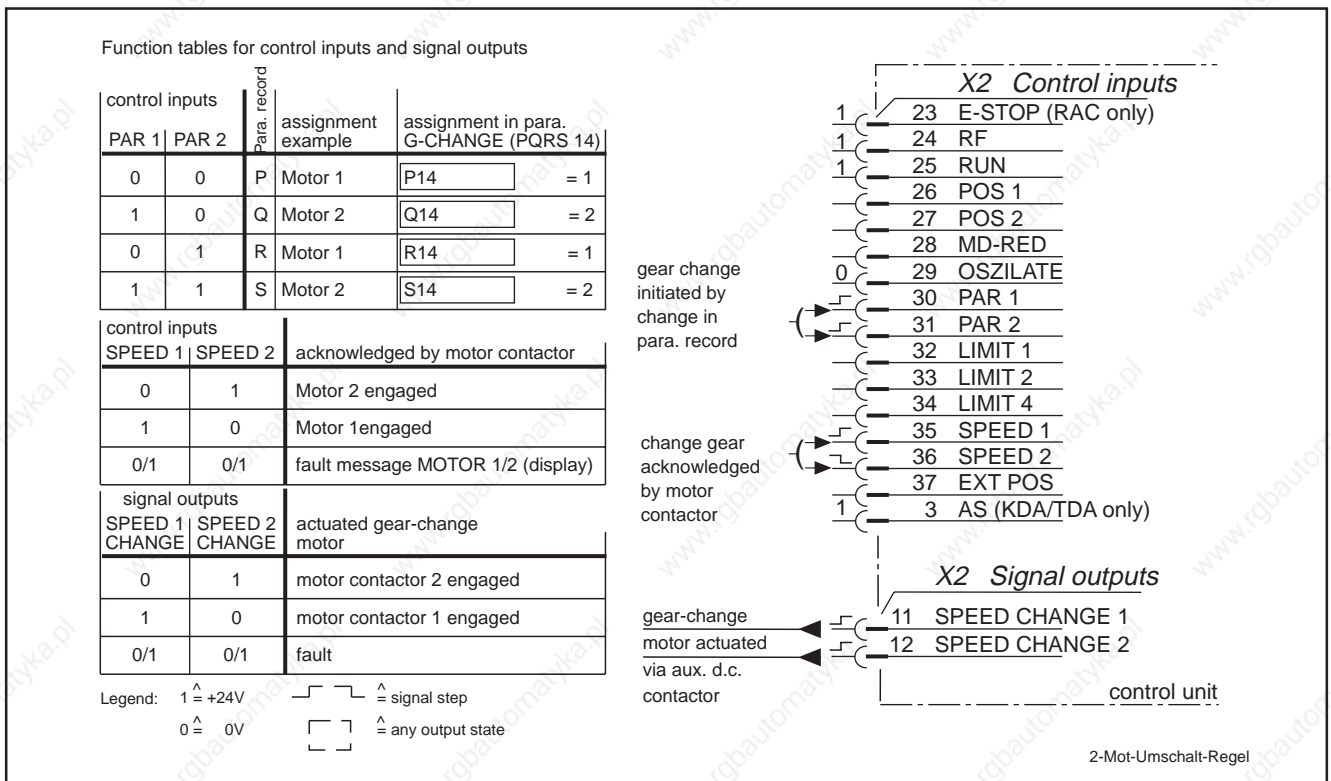

Figure 81: Control inputs and signal outputs for two-motor changeover

### 3. Controller Functions

Parameter	Designation	Function	value range or value	
SRQ P14	G-CHANGE	assignment to motor	- motor 1	< 1 >
			- motor 2	< 2 >
A06	FUNCT 2	additional encoder input is used as input for the motor feedback of motor 2	< 4 >	

 Parameter protocol!
 Para-2-Motorenumschalt

Figure 82: Parameters for two-motor changeover

**Note:** The values 1 or 2 must always be assigned to the G-CHANGE parameters in the four switchable parameter records. 0 is not allowed!

No spindle position can be performed via the spindle position encoder during two-motor changeover as the second encoder input is used for motor feedback from the second motor.

#### Functional sequence

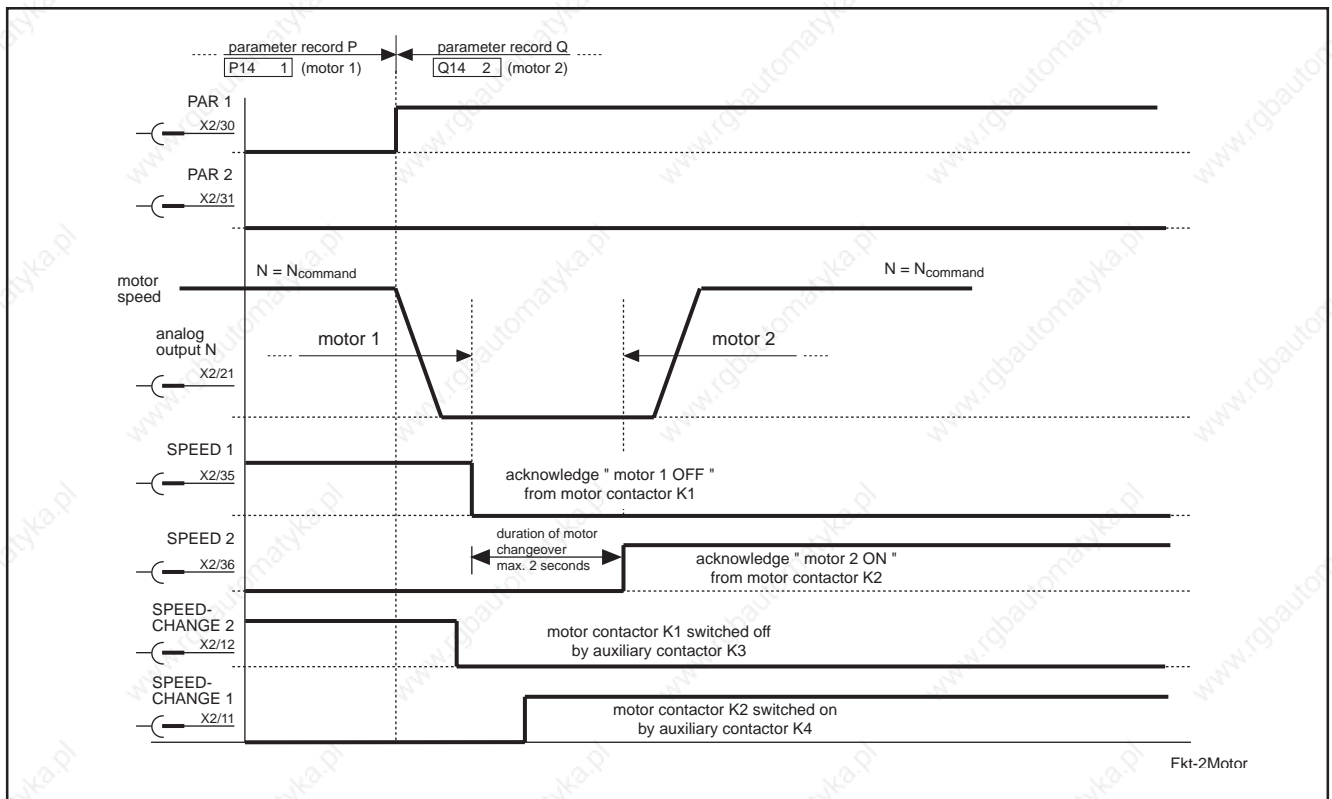

Figure 83: Functional sequence of two-motor changeover

**Note:**

Motor changeover must be completed within two seconds, otherwise "Motor 1/2" fault message appears and drive is switched off.

The auxiliary contactors must also change the temperature sensors of the motors, otherwise the active motor is not monitored.

Possible error messages in the display

- Motor 1/2
- NO TEMP
- FEEDBACK

### 3. Controller Functions

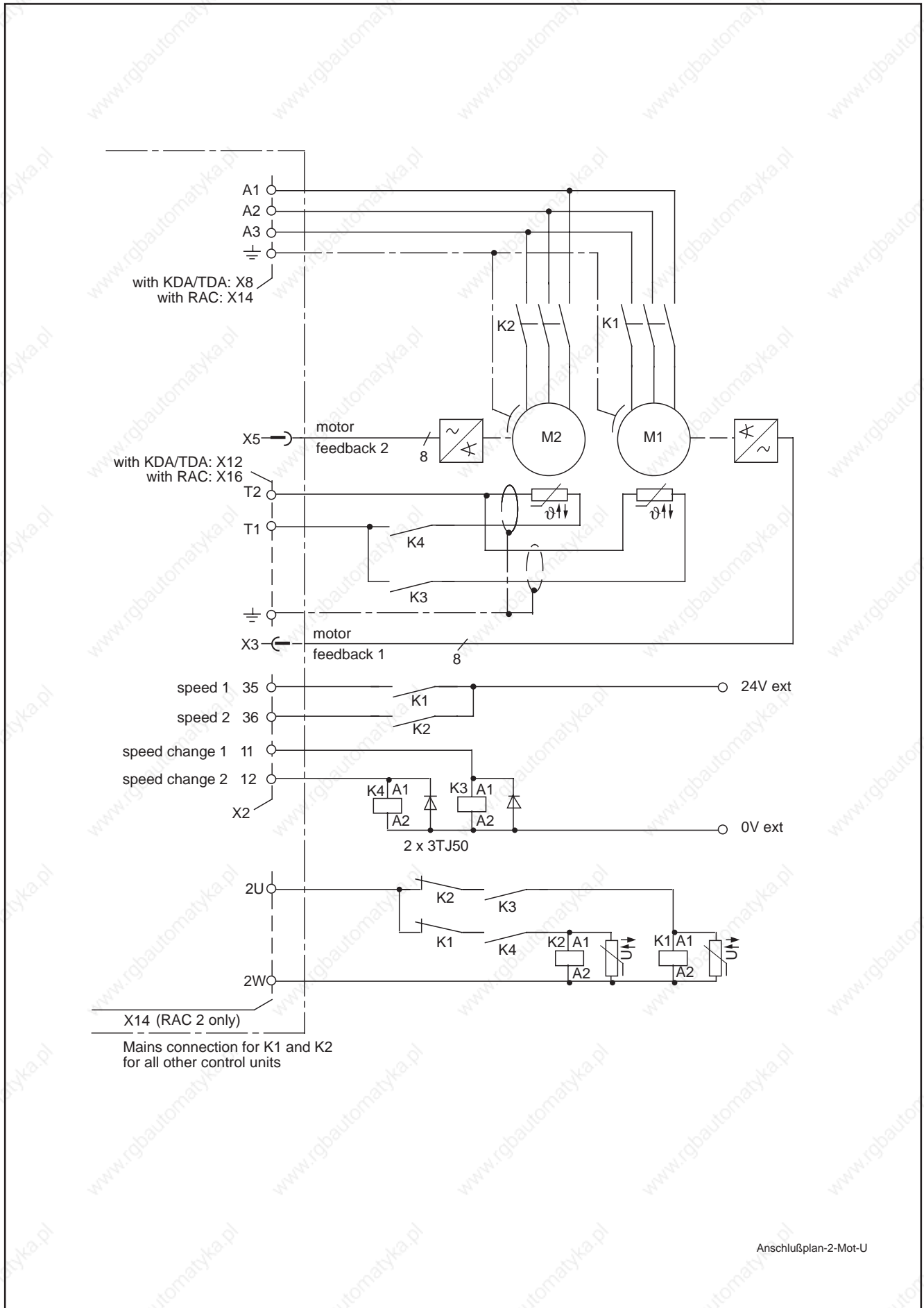

Anschlußplan-2-Mot-U

Figure 84: Connection diagram for two-motor changeover

### 3.17 Master-Slave Operation

Two drives can be combined as master/slave to increase drive power. Here, the master receives the speed command value from the NC; the slave, the torque command value from the master. Master-slave operation is used in a stiff mechanical connection for transmitting power to a common drive shaft.



**If the mechanical link between the slave and master drive is broken, the speed of the slave drive goes to maximum speed.**

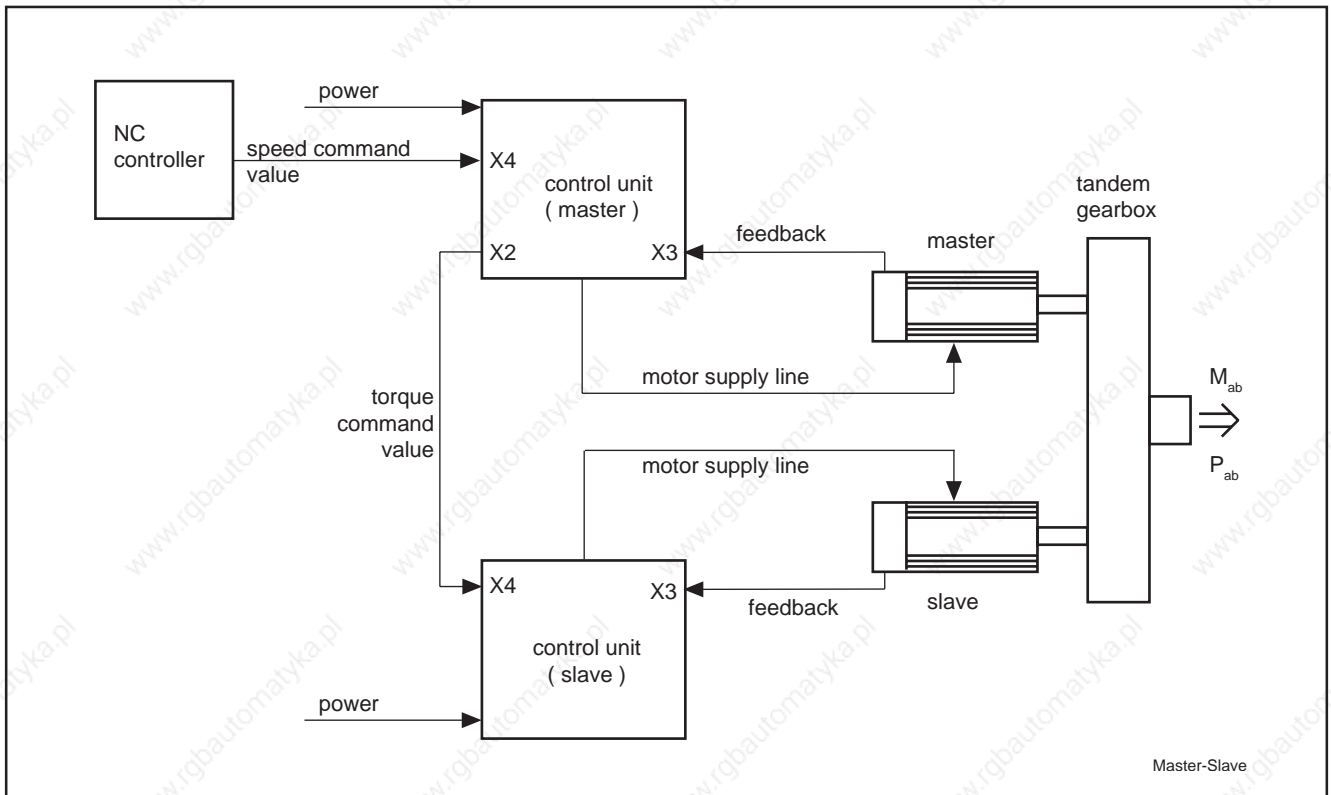

Figure 85: Schematic of master-slave drive for increasing drive power

#### Master drive data

With regard to hardware and software, the control units for the master-slave drive are identical and are defined as master and slave via parameters.

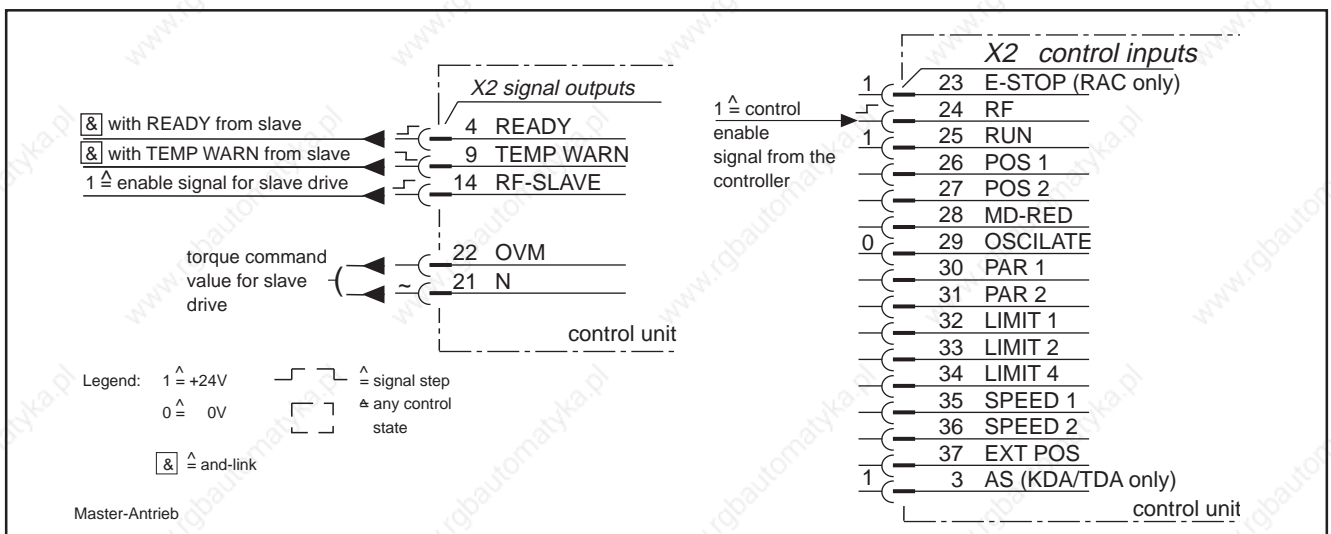

Figure 86: Control inputs and signal outputs for master drive

### 3. Controller Functions

Parameter	Designation	Function	Value range or value
A05	FUNCT 1	Analogue output N continuously outputs the torque command value, cannot be changed!	< 64 >

 Parameter protocol !
 Para-Master

Figure 87: Parameters for master drive

**Slave drive data** The slave drive must be fitted with an analogue command value interface (type code field "speed command value" = A).

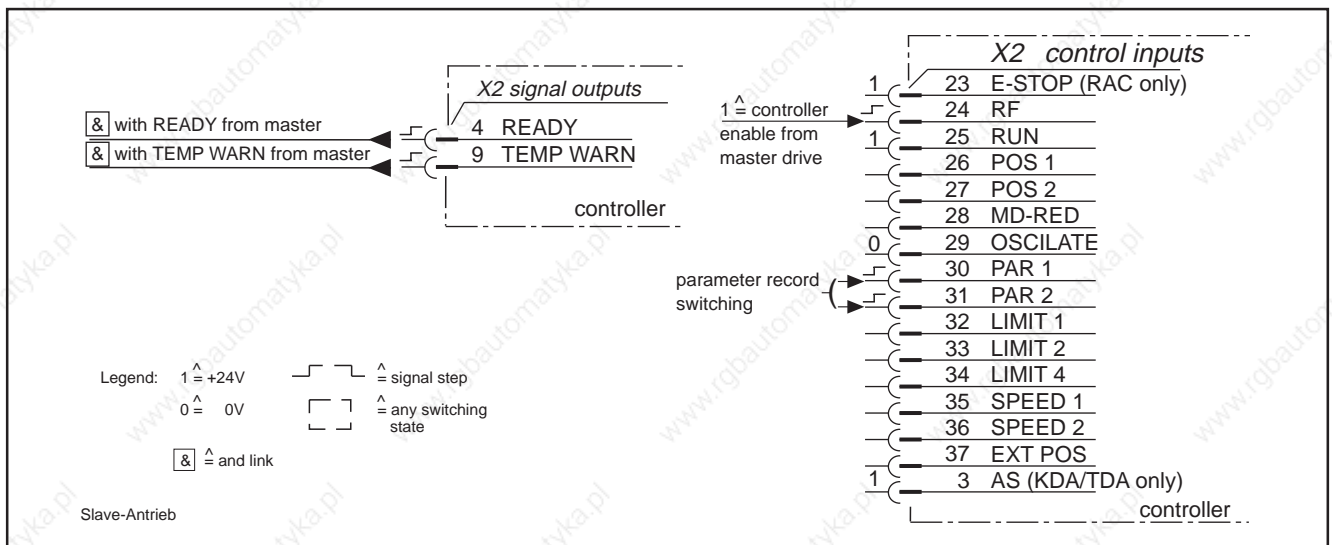

Figure 88: Control inputs and signal outputs for slave drive

Parameter	Designation	Function	Value range or value
A06	FUNCT 2	The voltage at analogue input E1/E2 (X4) is interpreted as torque command value - cannot be switched	< 8 >
S R Q P16	PQ-FUNCT	The voltage at analogue input E1/E2 (X4) is interpreted as torque command value - parameter-dependent switching	< 8 >

 Parameter protocol !
 Para-Slave

Figure 89: Slave drive parameters

**Switching torque-speed control** If a main spindle drive is programmed for torque input, the message SLAVE appears in the display.

**Matching slave to master** The drive can be switched from torque to speed input with the PQ FUNCT whilst the machine tool is operating.

**Polarity of the torque command value** The correct polarity (direction of rotation) must be observed when applying the torque command value to the slave. Connecting 0 V<sub>M</sub> of the master and E2 of the slave gives the same direction of rotation. If the master and slave act in opposition (M indication shows 100% for both), then the torque command value must be reversed.

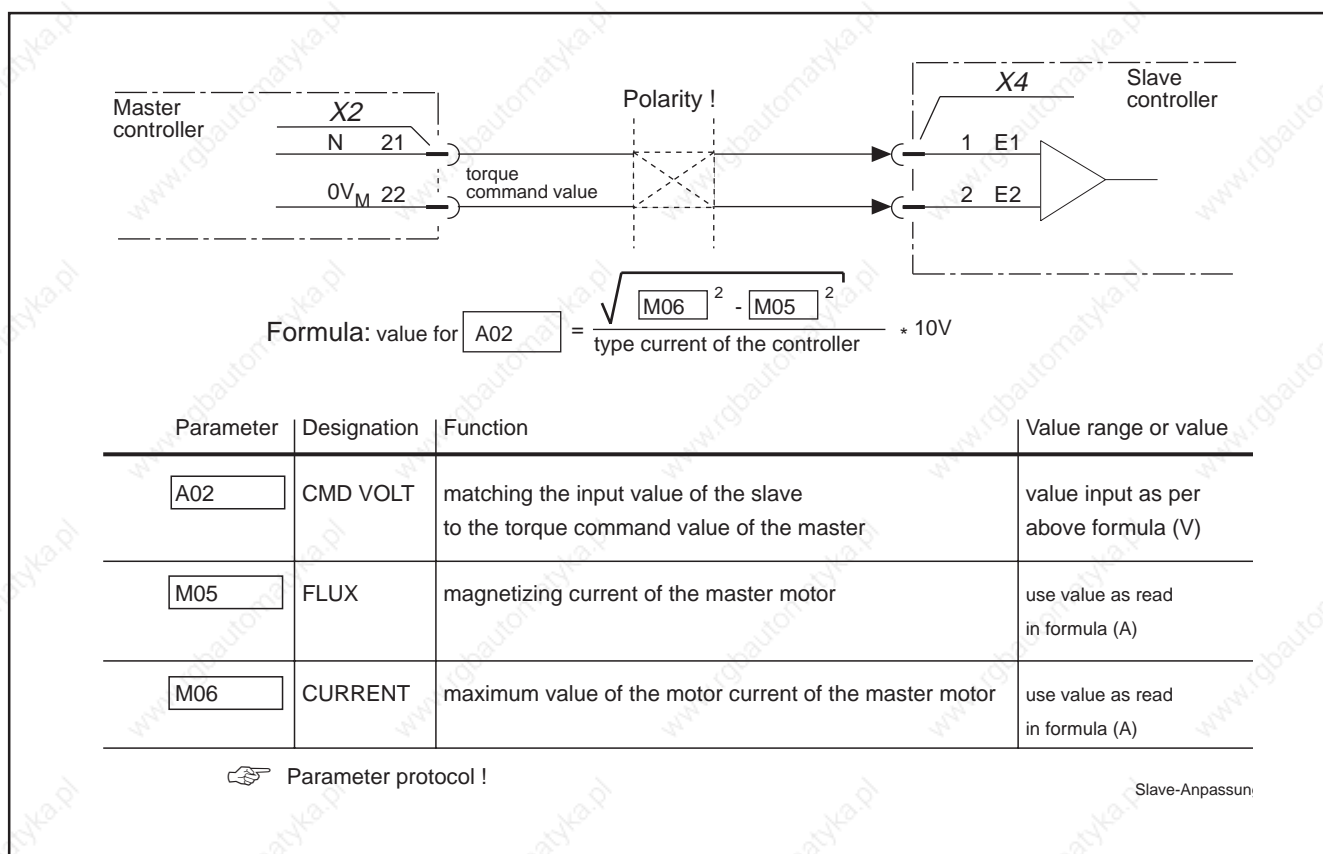

Figure 90: Data for matching the slave, parameters for slave

**Matching initial sensitivity** The slave drive is matched to the analogue output N of the master via slave parameter A02 so that both drives produce the same torque. To do this, read the values of parameter M05 and M06 and calculate the necessary value for A02 from the formula in Figure 89.

**Note:**

The motor parameter values (M parameters) for the master and slave must be identical.

### 3. Controller Functions

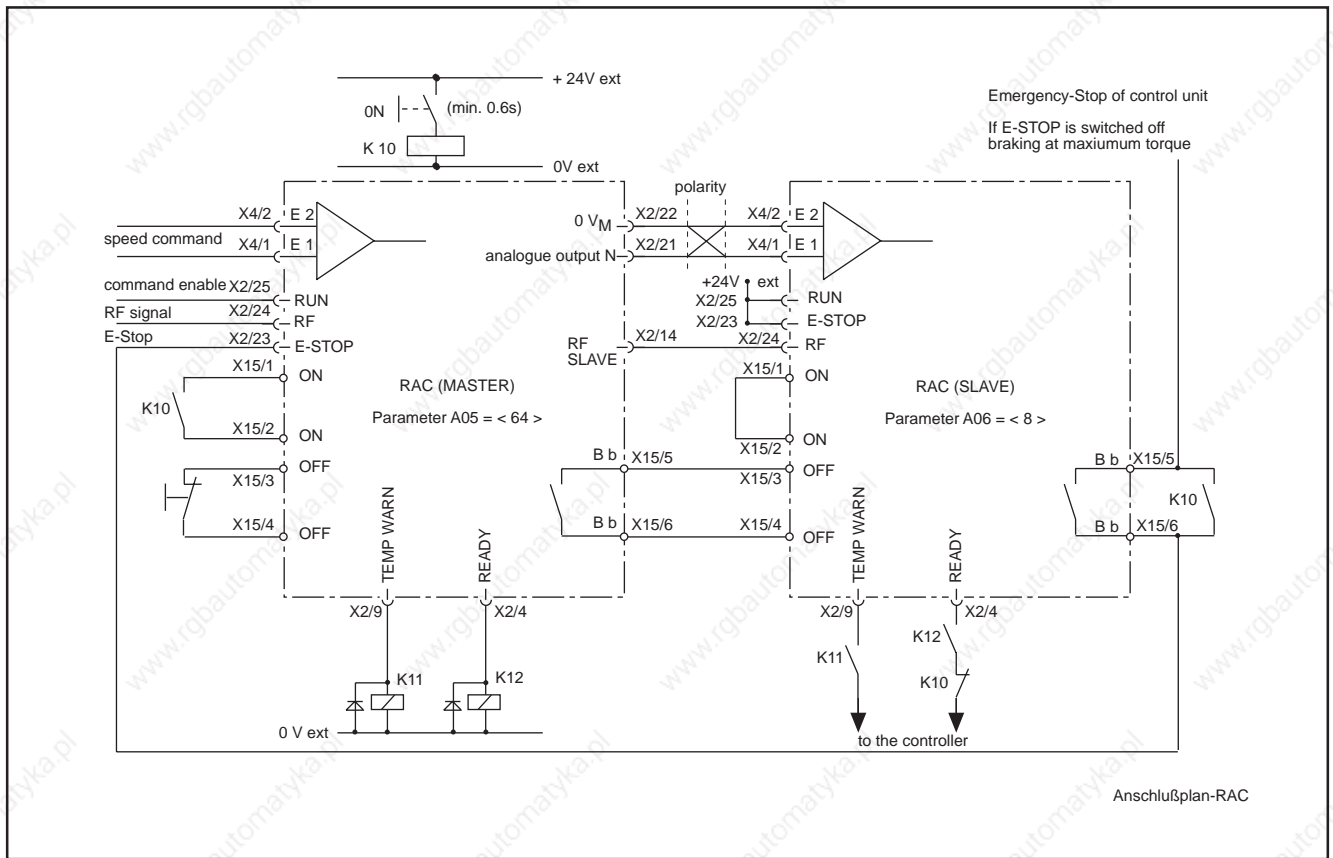

Figure 91: Connection diagram for master-slave drive with RAC

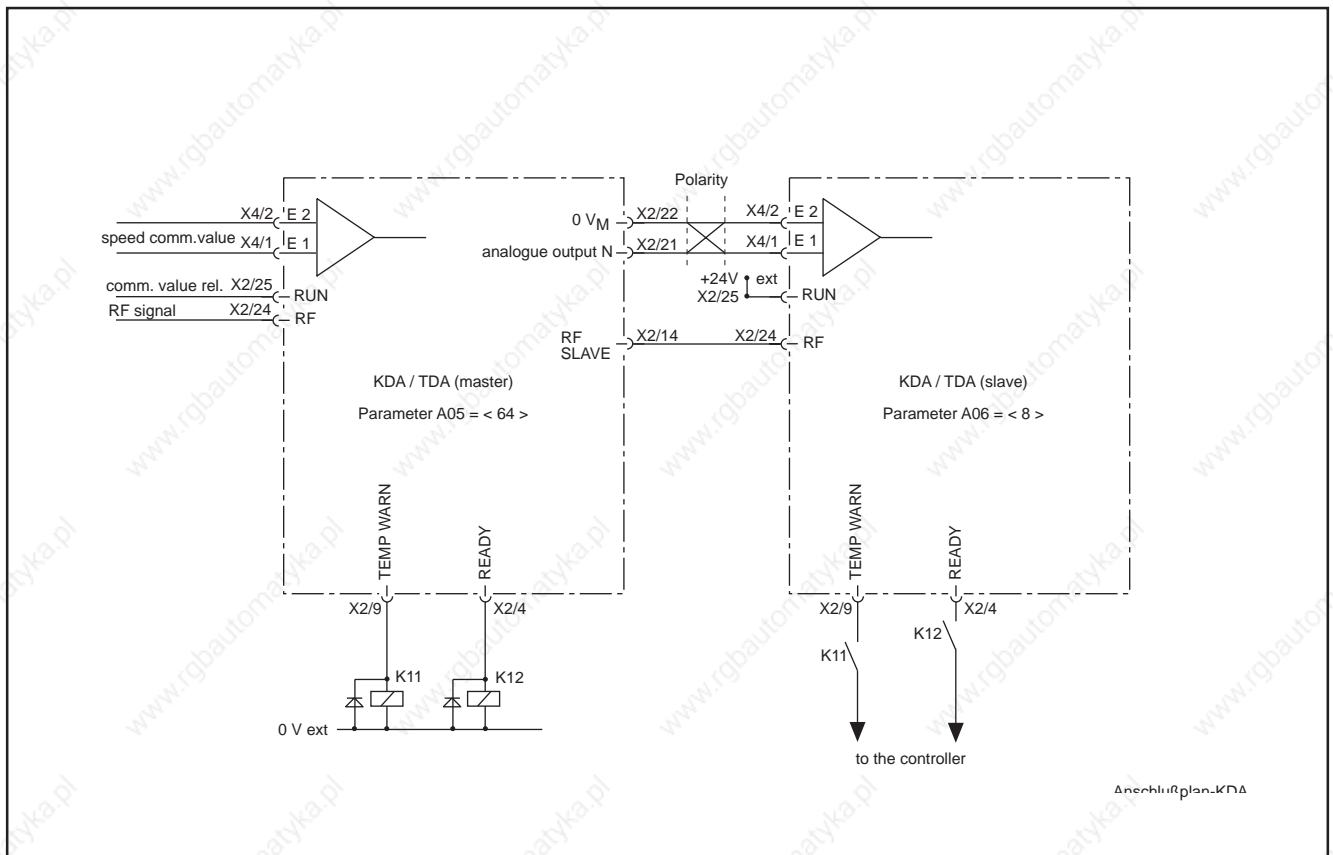

Figure 92: Connection diagram for master-slave drive with KDA/TDA

### 3.18 EMERGENCY-STOP circuit (RAC)

The EMERGENCY-STOP circuit is built into the RAC control unit. It requires no additional circuitry for the power-down logic.

In addition, energy released during braking is fed back into the mains.

For the E-stop circuit, there are two distinct methods for stopping the drive and switching off the power.

*Internal command value disconnect*

The speed command value is set to zero internally after the E-stop control inputs goes from 1 to 0. This can be effected immediately or via the speed command value ramps (selected via function parameters).

Power-down occurs when the motor shaft is stationary but no later than five seconds after the internal N command value is set to 0. If the command value is set to zero immediately, the drive brakes at maximum torque, just like when the drive follows steeply-set ramps.

*Command value input via the NC controller*

The motor coasts if the power is disconnected before the motor stops.

The OFF contact must be opened after the controller has stopped the drive. This disconnects the power.



**The E-stop system must be selected and tested according to the installation in use.**

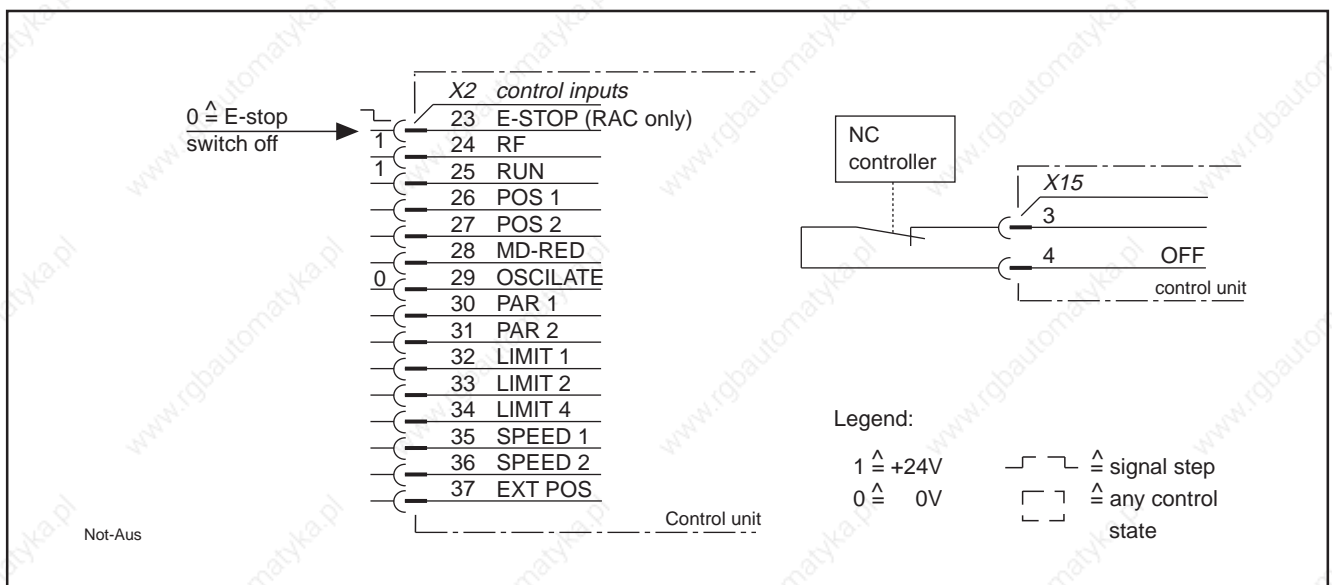

Figure 93: Control inputs for E-stop circuit

**Note:**

The message E-STOP appears in the display when the E-stop control input is at 0!

Parameter	Designation	Function	Value range or value
A06	FUNCT 2	Ramp active with E-Stop also	< 32 >

 Parameter protocol ! Para-NOT-AUS

Figure 94: Parameters to activate speed comand value ramps with E-Stop due to mains failure

### 3.19 Performance during mains failure (RAC)

To prevent the main spindle from coasting during a mains failure, the RAC control unit can also brake the asynchronous drive. This is done either at maximum or at approximately 1/5th of maximum braking torque with so-called direct-current braking.

#### DC braking

The energy regenerated during braking is converted into heat in the rotor of the motor. The braking time is approximately five times longer than that of controlled braking at maximum braking torque, but is adequate for many main spindle applications.

The permissible amount of braking energy depends on the size of the motor. Braking the load moment of inertia of the rotor from  $N_{\max}$  increases the rotor temperature by about 2K (°C). Additional moments of inertia increase the temperature-rise linearly.

When the motor is at operating temperature, the temperature-rise should not be more than 20K. This otherwise affects bearing service life. When idling, the thermal recovery time is about 30 minutes.

DC braking is included in the standard control unit and is activated in the standard parameter record.

#### Braking at maximum torque (RAC 2 and 3 only)

The energy regenerated in the RAC during braking is converted into heat via a load resistor (additional bleeder). Due to short deceleration distances and times, this type of braking is advantageous in servo applications. The deceleration time is the same as in regenerative braking. The permissible amount of energy depends on the controller:

RAC 3.1	120 kW
RAC 2.2	240 kW

Maximum-torque braking is only possible in the RAC 2.2 and 3.1 with the "additional bleeder" option (type code field = Z1)!

An additional bleeder cannot be integrated into the RAC 4.1!

### 3. Controller Functions

Parameter	Designation	Function	Value range or value
M15	MOT-FUNCT	no braking with power failure	< 0 >
		braking with power failure by " DC bus dynamic braking "	< 16 >

 Parameter protocol!

Para-Gleich-Brems

Figure 95: Parameter for d.c. braking

**Note:**

Braking is not possible with the set ramp or via the NC controller during d.c. braking!

Parameter	Designation	Function	Value range or value
A06	FUNCT 2	additional bleeder monitor (RAC 2.2 only)	- not working - active
		ramp active with mains failure	< 32 >
			< 256 >
SRQP16	PQ-FUNCT	motor brakes with mains failure	< 0 >
		the NC controller must brake the motor with power failure	< 256 >

 Parameter protocol !

Para-Brems-Max

Figure 96: Parameter for braking at maximum torque

**Note on bleeder monitor:**

So that the bleeder has time to cool down, braking operations with the additional bleeder must not be repeated in rapid succession. A cooling time of ten to 15 minutes is necessary after braking at maximum permissible energy. In addition, no large amounts of braking energy must be allowed to occur!

If bleeder overheating is detected during braking, the RAC automatically changes over to d.c. braking, if this is activated!

### Bleeder monitor features of the RAC 2.2

Activated bleeder monitoring prevents a device with overheated bleeder from being switched on again. The display then shows „BLEEDER“.

Activated bleeder monitoring also signals „BLEEDER“, if the RAC 2.2 has been inadvertently installed with a bleeder!

### Bleeder monitor features of the RAC 3.1

Bleeder monitoring is always operative when a bleeder is fitted. A missing bleeder is therefore not diagnosed!

During a mains failure, in both control units RAC 2.2 and 3.1 (with additional bleeder option), the decision to brake the drive immediately or whether the internal ramp or the NC controller specifies the speed command value for deceleration, can be made with the PQ FUNCT value in the switchable parameter records. The tool and workpiece can thus be separated without damage during NC braking.

*Possible error message in display*

BLEEDER

## 3.20 Performance during mains failure and E-stop (KDA, TDA)

Apart from the main drive with KDA or TDA, servo drives can also be connected in the modular drive system to the same power supply module.

Modular drive system requirements:

- Stopping the servo drives has priority over stopping the main drive.
- The total power regenerated by the drives during braking must not exceed the regenerated power of the supply unit, otherwise the voltage in the DC bus circuit rises to inadmissible levels.
- If the DC bus voltage, as a result of the power that is regenerated when the drives are braking, reaches the permissible limit value, then the KDA/TDA interrupts the braking of the main spindle drives. If the voltage drops, then the main spindle drives return to braking mode.

*Internal command value to zero*

The command value is switched to zero either abruptly or with the use of ramps, depending upon the parameter FUNCT2 (A06).

*NC control unit command value to zero*

If the control unit must separate tool and workpiece by switching the command value to zero, then an NCB jumper must be installed on the supply module (KDV, TVD or KVR, etc). All drives connected to the supply module must, in this case, be braked by the control unit via the speed command value!

### 3.21 Starting lockout in KDA/TDA

For safety reasons, the main spindle should be stopped when setting-up machine tools. INDRAMAT main spindle drives are thus fitted with a starting lockout.

- The modular system's main drive remains selectively and reliably shut down.
- Disconnection is safe, even if the electronics malfunction, since the opto-couplers are switched off and the power bridge is inhibited.
- Even with defective power transistors, no rotating field can be generated with an active starting lockout.

**Note:**

If the AS control input is at 0, the display shows DISABLED and the starting lockout is activated.

If the AS control input goes from 0 to 1, the controller enabling signal must be applied once again (RF control input goes from 0 to 1) in order to start the drive.

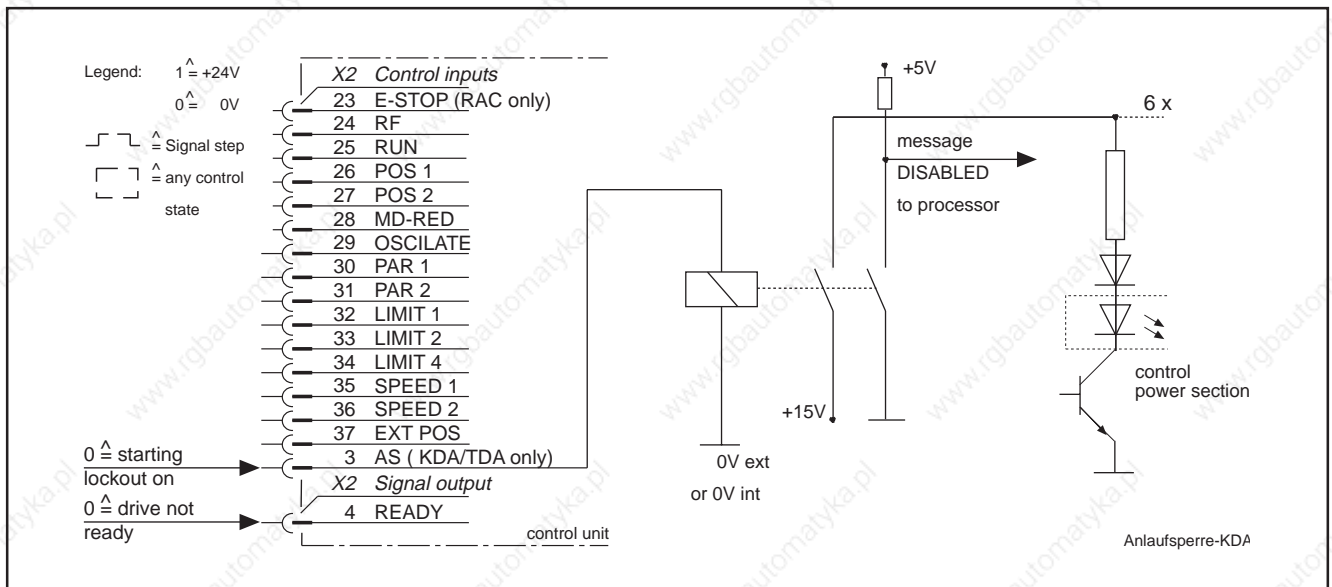

Figure 97: Control inputs for starting lockout in KDA; internal circuit of controller

If the starting lockout is active, the READY signal output goes to 0. The Bb potential-free contact remains closed so that the other control units of the drive package are not shut down.



**Safety note: Remove connector plug from terminal strip X2 to ensure that the AS input is set to 0. The starting lockout (AS) does not meet personnel safety requirements in the vicinity of the main spindle!**

**3.22 Serial Interface (option) – in preparation**

**3.23. SERCOS interface (option) - in preparation**

**3.24 Incremental Encoder Output (option) –  
see Section 9**

## 4. Diagnostics and Fault Clearance

The control unit shows main spindle drive operating states and faults in the display. Requirements are that the drive is in operating mode (mode switch to the right).

### 4.1 Operating Status Diagnostics

The green „READY“ LED comes on. The operating states appear in the display.

**DISABLED (KDA only)** The drive is free of torque, the power output stage is inhibited. The AS (X2/3) control input is at 1.

Note: see Section 3.20

**E-STOP (RAC only)** The drive is free of torque when at standstill. The E-STOP (X2/23) control input is not at 1.

Note: see Section 3.18

**HOMING** The drive searches for the spindle reference signal at the speed set in parameter P-MAXRPM, or looks for the spindle feedback or motor feedback zero pulse at the speed set in parameter POS RPM (PQRS 18).

Note: see Section 3.6

**IN POS** The spindle or rotor position has reached the position command value within tolerance. The tolerance is the value of parameter P-WINDOW (PQRS 21).

Note: see Section 3.6

**NO POWER** The DC bus voltage in the control unit is less than 400 V (KDA/TDA).

Note: see Sections 3.1

**NO RF** Controller enabling signal not input. The RF control input (X2/24) is not at 1.

Note: see Section 3.7

**NO RUN** The applied speed command value is switched off internally. The drive is controlled to zero speed without drift. The RUN control input (X2/25) is at 0.

Note: see Section 3.6.1

**N = NCMD** The speed of the motor has reached the speed command value within the tolerance (value in parameter MAX DEV (A04)) parameter.

Note: see Section 3.3

**N \* NCMD** The speed of the motor deviates from the command value speed by more than the specified tolerance. The tolerance is the value of parameter MAX DEV (A04).

**Note:**

The message appears in the acceleration and braking mode if the speed command value is changed abruptly. It can also appear when the drive is purely P-controlled under load!

Note: see Section 3.3

***N<NMIN***

The speed of the motor is less than the value set in parameter MIN RPM (A03).

Note: see Section 3.3

***OSCILATE***

The motor speed oscillates at the value set in the OSCI RPM (A20) parameter to support the gear change. The OSCILATE (X2/29) control input is at 1.

Note: see Section 3.15.2

***POS ORDER***

The drive has received a position command via POS1 (X2/26) and POS2 (X2/27) control inputs or the digital position input (optional) and approaches the command value position.

Note: see Section 3.6

***SLAVE***

**Cause:**

The drive is parametrized as the slave drive. It now operates in the torque control mode.

Note: see Section 3.17

## 4.2 Fault Diagnostics

The red „FAULT“ LED comes on. The fault messages appear in the display. The fault messages must be cancelled with the red accept key after the fault has been remedied (reset).

**ADW2** Cause:  
Plug connector X7 on the CDR board in the control unit has been fitted with an ADW2 analogue speed command value interface.  
Remedy:  
Switch off the control unit. Replace ADW2 with ADW3. Contact Indramat customer service!

**BLEEDER** Cause:  

- Bleeder monitor has tripped due to overheating.
- The bleeder in the control unit is faulty or no bleeder has been fitted.

Remedy:  

- Check whether the bleeder resistor in the upper part of the control unit is faulty (visual inspection). If the bleeder is OK, then allow for the cooling-down period (approximately 15 minutes).
- If the control unit is not fitted with the "additional bleeder" option, <256> is incorrectly contained in the value of FUNCT2 (A06).

**BS (KDA only)** Cause:  
The limiting current in the control unit set on the electronic cut-out has been exceeded.  
Remedy:  
Check the motor cable for a short-circuit or earth fault. Check the motor for shorted windings or earth fault.

**DACFAULT** Cause:  
Error on the CDR board.  
Remedy:  
Switch control unit off. Replace CDR board. Contact Indramat customer service!

**DC-FAULT** Cause:  
The DC bus circuit is not charging up properly when the power contactor is energized.  
Remedy:  

- Check supply cable is securely connected to mains terminal.
- Remove possible short-circuit in the DC bus circuit (L+,L-) (KDA/TDA and RAC2 only).
- Otherwise, contact Indramat customer service!

**EARTH CON** Cause:  
Earth fault in motor cable or DC bus circuit.  
Remedy:  
Switch off control unit. Check motor cable (cabinet cable entry gland?) and replace if necessary. Check motor. With KDA, check the DC bus wiring.

**EEPROM** Cause:  
No EEPROM (IC3) in the programming module, or the existing EEPROM is faulty.

Remedy:

Switch control unit off. Insert EEPROM into programming module, or replace faulty EEPROM. Contact Indramat customer service!

**FEEDBACK** Cause:  
• Wrong value in FEEDBACK (M03) parameter. This type of motor feedback requires a different parameter value.

• Faulty or wrong feedback cable.

Remedy:

- Set parameter value in M03 which suits the type of motor feedback.
- Repair or replace feedback cable.

Note: see Section 5.3

**GEAR BOX** Cause:  
The gear box cannot be engaged or the reduction stage acknowledgment signal is faulty.

Remedy:

Switch the control unit off. Examine contactor wiring and acknowledgement contacts. Check correct operation of change gear.

Note: see Section 3.15.1

**HOMING** (*does not go off after spindle rotates*)

Cause:

- No spindle reference signal at EXT POS control input (X2/37).
- No spindle or motor feedback zero pulse.

Remedy:

- Check correct connections and closing angle of spindle reference switch!
- Check feedback leads!

Note: see Section 3.6

**KK TEMP** Cause:  
The heatsink of the control unit has overheated. The TEMPWARN signal (X2/9) was ignored. The control unit has shut down.

Remedy:

Check the control unit fan and airways. Check ambient temperature. Check link between TEMPWARN signal output (X2/9) and controller. Reset required.

Note: see Section 3.11

***KK WARN*** Cause:  
The heatsink of the control unit has reached the cut-off temperature. The TEMP WARN signal output (X2/9) has switched from 1 to 0.

Remedy:

With KK WARN, the drive must be perceptibly unloaded because a further rise in temperature at the heatsink means the drive switches off after 30 seconds!

Note: see Section 3.11

***MOT TEMP*** Cause:  
The temperature of the motor windings has reached 155°C. The TEMPWARN signal was ignored. The control unit has switched off.

Remedy:

Check motor fan, airways, load cycle and interconnections between the TEMPWARN signal output and the controller. Reset required.

Note: see Section 3.11

***MOT WARN*** Cause:  
The motor has reached a temperature of 145°C. The TEMP WARN signal output (X2/9) has switched from 1 to 0.

Remedy:

Check motor fan, airways and load cycle. Cancel the fault message with the red accept key!

Note: see Section 3.11

***MOTOR 1/2*** Cause:  
No motor contactor changeover acknowledgement.

Remedy:

Check the wiring for agreement with the connection diagram.

Note: see Section 3.16

***NO INPUT*** Cause:  
No command value interface card is inserted, or the one fitted is not recognized.

Remedy:

Switch off the control unit. Check command value interface. Replace if necessary. Contact Indramat customer service!

***NO MAINS*** Cause:  
***(RAC 3 only)*** No voltage at mains terminals L1,L2,L3 or voltage too low.

Remedy:

Check mains supply conditions!

***NO RAC 2.2*** Cause:  
***(RAC 2.1 only)*** Software and equipment do not match.

Remedy:

Use correct programming module (AS4./...).

**NO TEMP** Cause:  
• Broken connection between motor temperature sensor and control unit, or faulty temperature sensor (signal appears approximately ten minutes after fault occurs).

Remedy:

- Check temperature sensor connections.
- If sensor is faulty, contact Indramat customer service!

Note: see Section 3.11

**NO 8 MHz or NO 12 MHz** Cause:  
Software in programming module does not match control unit.

Remedy:

Use a programming module which matches the control unit. Contact Indramat customer service.

**NO 8V** Cause:  
The control unit's 8V supply is faulty.

Remedy:

Contact Indramat customer service.

**NO 15V** Cause:  
The  $\pm 15V$  supply of the control unit is faulty.

Remedy:

- Check bus connecting cable (in KDA)
- Contact INDRAMAT customer service (with RAC)

**NO 24V** Cause:  
The  $\pm 24V$  supply of the control unit is faulty.

Remedy:

- Check bus connecting cable (in KDA)
- Contact INDRAMAT customer service (with RAC)

**NO 24 VEX** Cause:  
No external voltage for the control inputs and signal outputs (X2/1 and 19), incorrect polarity or outside the tolerance range.

Remedy:

- Check connections and voltage of external +24V supply. The voltage level must be between 18V and 36V. If the external +24V is OK, the fault message is cancelled automatically.
- If the external +24V is absent, the control unit's internal +24V/OV supply can also be used (link +24Vint/OVint to +24Vext/OVext on X2!).

Note: see Section 3.1

**OVER VOLT (RAC only)** Cause:  
The mains voltage exceeds the rated device voltage by more than 15%. The power contactor in the unit cannot be engaged.

Remedy:

Check mains conditions. If necessary, use transformer to match mains voltage.

- PARA LOST** Cause:  
Programming module has no parameter values. The values were either not loaded or erased.
- Remedy:  
Slide mode switch to left and press red button. This loads the general base parameters for running the drive. The load operation is completed when the message "BASISPAR" appears in the display. Pressing the red button again puts the drive into parameter mode. The base parameters are not the optimum ones for the drive and should be replaced (AS ../..). (Refer to parameter list supplied with the programming module.)
- PHASE (RAC only)** Cause:  
No mains supply clockwise field, or one of the three phases is missing (phase failure in RAC 3 only).
- Remedy:  
Check mains conditions.
- POS ERROR** Cause:  
Contouring error monitor has tripped during spindle positioning with spindle reference switch. Drive cannot follow the position input.
- Remedy:
- Check whether spindle is jammed, sluggish or coupling is faulty.
  - Check whether drive's torque reduction is active. Switch off torque reduction (set MD-RED (X2/28) to 0)!
  - Reduce the positioning rate (POSRPM).
- RAC or KDA TYPE** Cause:  
The value set in CURRENT parameter (M06) exceeds the rated current of the control unit.
- Remedy:  
Set the value in accordance with the parameter list supplied with the programming module!
- RAM FAULT (RAC only)** Cause:  
Fault while checking RAM in control unit.
- Remedy:  
Switch off control unit. Replace CDR board. Contact Indramat.
- RF AGAIN** Cause:  
The drive is waiting for a new controller enabling signal in order to run again.
- Remedy:  
The RF control input (X2/24) must be switched from 0 to 1 again.
- RSK FAULT (RAC 3 only)** Cause:  
The RSK board is inoperative.
- Remedy:  
Switch off control unit. If fault is indicated after switching on again, contact Indramat.

*RSKCURNT (RAC 3 only)* Cause:  
Overcurrent during regenerative feedback.  
Remedy:  
Check if infeed voltage is below minimum.

*S-CIRCUIT* Cause:  
Short-circuit in motor cable.  
Remedy:  
Switch off control unit. Check motor cable (control cabinet cable gland?) and replace, if necessary. Check motor.

*SPINDLE* Cause:  
No speed information from spindle position encoder.  
Remedy:  

- Check coupling between spindle and drive.
- Check electrical connections between spindle feedback and control unit!

Note see Section 3.13

*X12 ADW* Cause:  
Connector strip X12 on CDR board has been fitted with an ADW2 analogue interface.  
Remedy:  
Switch off control unit. Replace ADW2 board with correct interface board. Contact Indramat.

*2X SIM* Cause:  
The control unit is fitted with two serial interfaces. Only one serial interface is permitted.  
Remedy:  
Compare interface configuration indicated by type code and the interface in the control unit. Incorrect interface must be replaced. Contact Indramat.

## 5. Overview of Parameters

### 5.1 General Parameters (A Parameters)

The general parameters are always active when the drive is in operation. Changes can only be made to parameter values in the parameter mode. When the parameter mode is selected, the drive brakes to the set ramps and is then free of torque.

Parameter	Designation	Function	See sec.	Value range or value
A01	MAX RPM	maximum motor speed	3.2	1.....24000 (1/min)
A02	CMD VOLT	analogue voltage for MAX RPM	3.2	6.....10 (V)
A03	MIN RPM	if speed command and motor speed are below MIN RPM then signal output "N < MIN" goes to 1	3.3	1.....999 (1/min)
A04	MAX DEF	maximum speed deviation from command value within signal output "N = CMD" goes to 1	3.3	1.....999 (1/min)
A05	FUNCT 1	see function table for A05		sum 0.....9999 ( $\Sigma < >$ )
A06	FUNCT 2	see function table for A06		sum 0.....9999 ( $\Sigma < >$ )
A07	OFFSET	phase offset of the zero impulse	3.6.1	0.....360,0° (x deg.)
A08	POS 1	spindle position 1	3.6.1	0.....360,0° (x deg.)
A09	POS 2	spindle position 2	3.6.1	0.....360,0° (x deg.)
A10	POS 3	spindle position 3	3.6.1	0.....360,0° (x deg.)
A11	ENCODER	resolution of the spindle position encoder or i.d. of Indramat encoder	3.6.4	128,256,512,1024,2048, 4096,8192, 3 or 4
A12	LIMIT 1	maximum spindle speed 1	3.12	1.....24000 (1/min)
A13	LIMIT 2	maximum spindle speed 2	3.12	1.....24000 (1/min)
A14	LIMIT 3	maximum spindle speed 3	3.12	1.....24000 (1/min)
A15	LIMIT 4	maximum spindle speed 4	3.12	1.....24000 (1/min)
A16	LIMIT 5	maximum spindle speed 5	3.12	1.....24000 (1/min)
A17	LIMIT 6	maximum spindle speed 6	3.12	1.....24000 (1/min)
A18	LIMIT 7	maximum spindle speed 7	3.12	1.....24000 (1/min)
A19	BAUDRATE	transmission rate for serial interface	3.23	50,75,110,150,300,600, 1200,2400,4800,9600,19200
A20	OSCI RPM	oscillating speed for gear switches	3.15	1.....200 (1/min)

 Parameter protocol ! Para-allgemein

Figure 98: Overview of general parameters (A)

#### Note:

The totals of the summands ( $\Sigma < >$ ) assigned to the functions should be entered as parameter values of the function parameters FUNCT1 (A05) and FUNCT2 (A06) (see functions table). An additions list is added to the parameter list for recording the necessary summands.

## 5. Overview of Parameters

Function	Relevant summand		Function	See section
torque limit if control input MD-RED is on 1	< 1 >	< 0 >	Torque and power limit if control output MD-RED is on 1	3.9
analogue speed command value below value in parameter MIN RPM (A03) is invalid (drift prevention)	< 2 >	< 0 >	analogue speed command value is always 1	3.3
torque off if speed less than value in parameter MIN RPM (A03)	< 4 >	< 0 >	no speed-dependent torque switch off	3.3
an existing second encoder input is being ignored ( type code field " 2nd encoder input " = P )	< 8 >	< 0 >	positioning on spindle if 2nd encoder input present, otherwise on motor shaft	3.6.4
braking of the motor without overshoot (speed command dependent switch off of I-amplification of the N-control unit)	< 16 >	< 0 >	drive overshoots during braking as I amplification of the N control unit is always active	3.7
After powering up, power $P = U_D \cdot I_D$ is switched to analogue output N	< 32 >	< 0 >	after power up, speed N is switched to analogue output N (basic state)	2.2.2
Master drive, analogue output N constantly issues speed command value	< 64 >	< 0 >	analogue output N can be switched via user interface (see 2.2.2)	3.17
After switching on, the motor temperature T is switched to analogue output N	< 128 >	< 0 >	after power up, speed N is switched to analogue output N (basic state)	2.2.2
Signal output N = CMD remains active even without RF signal (control input RF = 0 )	< 256 >	< 0 >	signal output N = CMD is only active with drive running	3.3
Change in definition of parameter MAX DEV (A04), speed deviation equals $MAX DEV \cdot 0.1\%$ of current speed command value	< 512 >	< 0 >	the value of parameter MAX DEV means ( 1 / min )	3.3
$N_{comm\ A\ 01} = \frac{A\ 01}{16383} \cdot N_{comm\ digital}$	< 1024 >	< 0 >	no change in value of the digital speed command value	3.2.2

 Additions list!
 Fkt-TabelleA05

Figure 99: Function table for parameter FUNCT1 (A05)

## 5. Overview of Parameters

Function	Relevant summand		Function	See section
Value in parameter LOAD LIM ( PQRS 19 ) means torque in % of peak torque	< 1 >	< 0 >	value in parameter LOAD LIM( PQRS 19 ) means power in kW	3.10
Type code field "speed command value" = D floating decimal point of the speed command value Type code field " speed command value " = A and " add. interface " = D Analogue speed comm. value in parameter record P, Q Binary speed command value in parameter record R, S	< 2 >	< 0 >	Type code field " speed command value" = D binary coded speed command value	3.2.2
Type code field "2nd enc. input " = P 2nd encoder input is used as motor feedback of motor 2	< 4 >	< 0 >	Type code field " 2nd enc. input " = P 2nd encoder input is input for spindle feedback	3.16
Slave mode: voltage at analogue input E1/E2 at terminal strip X4 is interpreted as torque command value	< 8 >	< 0 >	analogue input E1/E2 at terminal strip X4 supports speed default	3.17
Spindle positioning with speed POS RPM ( PQRS 19 ), rotational direction as per qualifying sign of the presently applied speed command value	< 16 >	< 0 >	spindle positioning with speed POS RPM ( PQRS 19 ), using shortest path	3.6.1
with control input EXT POS = 1, control input E-STOP = 1 → 0 and power failure: command value ramp or smoothing active!	< 32 >	< 0 >	with control input EXT POS = 1 control input E-STOP 1 → 0 and mains failure: command value ramp or smoothing inactive!	3.5 3.4
with RAC 3 only: compensation of mains undervoltage active	< 64 >	< 0 >	with RAC 3 only: compensation of mains undervoltage inactive	
with control input EXT POS = 1: at analogue input N equals 10V = speed P-MAXRPM ( PQRS15 )	< 128 >	< 0 >	10V = speed MAXRPM ( A01 )	3.2
with RAC 2.2 only: bleeder monitoring active	< 256 >	< 0 >	with RAC 2.2 only: bleeder monitoring not operating	3.19
switching analogue input M: output of the approximate drive torque and switching of analogue output N: torque command value is output	< 512 >	< 0 >	no switching of analogue outputs M and N via function parameter ( A06 )	3.10.1

Additions list !

Fkt-TabelleA06

Figure 100: Function table for parameter FUNCT2 (A06)

## 5.2 Switchable parameter records (P,Q,R,S parameters)

These records can be selected when the drive is running. Use control inputs PAR1 and 2. Change parameter values only in parameter mode. When the parameter mode is selected, the drive brakes to set ramp and is then torque free. Refer to section 3.14 for explanations of the switchable parameter records.

Parameter	Designation	Function	See section	Value range or value
PQR S01	RAMP 1	increase in speed command value ramp 1	3.4 ; 3.5	0.....999 ( rad/s <sup>2</sup> )
PQR S02	RPM 1	end speed of ramp 1	3.4 ; 3.5	0.....24000 (1/min)
PQR S03	RAMP 2	increase in speed command value ramp 2	3.4 ; 3.5	0.....999 ( rad/s <sup>2</sup> )
PQR S04	RPM 2	end speed of ramp 2	3.4 ; 3.5	0.....24000 (1/min)
PQR S05	RAMP 3	increase in speed command value ramp 3	3.4 ; 3.5	0.....999 ( rad/s <sup>2</sup> )
PQR S06	MD-RED	torque limit	3.9	1.....99 (1/min)
PQR S07	P-GAIN 1	P-gain 1 of the speed controller	3.7	0.....20.0
PQR S08	I-GAIN 1	I-gain 1 of the speed controller	3.7	0.....20.0
PQR S09	GAIN RPM	changeover speed P-I-GAIN 1 to P-I-GAIN 2	3.7	0.....9999 (1/min)
PQR S10	P-GAIN 2	P-gain 2 of the speed controller	3.7	0.....9.99
PQR S11	I-GAIN 2	I-gain 2 of the speed controller	3.7	1.....9999
PQR S12	GEAR IN	gear ratio $i = \frac{N_1}{N_2}$ $N_1 = \text{motor speed}$	3.6; 3.12	1.....9999
PQR S13	GEAR OUT			1.....9999
PQR S14	G-CHANGE	allocation of the gear stage or motor	3.15; 3.16	0,1,2
PQR S15	P-MAX RPM	motor speed for additional weighting of the analogue speed command value voltage	3.2	1.....24000 (1/min)
PQR S16	PQ-FUNCT	see function table of PQRS 16		$\Sigma < >$
PQR S17	POS GAIN	gain factor in position control loop	3.6	0.....99.9 ( 1/ s )
PQR S18	POS RPM	positioning speed (limited to 30*POSGAIN)	3.6	1.....9999 (1/min)
PQR S19	LOAD LIM	signal limit for drive output	3.10	1.....99 ( % or kW )
PQR S20	ALPHA	corrective factor of the phase offset		0.....9.99
PQR S21	P-WINDOW	tolerance window within which the message "INPOS" is output	3.6	0.01.....99.99 ( $\chi$ ° )

 Parameter protocol! Para-umschaltbar

Figure 101: Overview of switchable parameters (PQRS)

Note: Enter the totals of the summands ( $\Sigma < >$ ) assigned to the functions as the parameter value of the function parameter PQ FUNCT PQRS 16 (see function tables). An additions list is added to the parameter list for recording the summands. ALPHA parameter (PQRS 20) is used to correct the phase angle between the motor current and the motor voltage in the constant torque range. In the RAC, the value is permanently set to 1.0.

## 5. Overview of parameters

Function	Relevant summand		Function	See section
If control input EXT POS = 1: analogue N command value via E3/E4 ( X4 )	< 1 >	< 0 >	If control input EXT POS = 1: analogue N command value via E1/E2 ( X4 )	3.2
Rotational direction of motor shaft and spindle or spindle feedback is counterclockwise	< 2 >	< 0 >	Rotational direction of motor shaft and spindle or spindle feedback is the same	3.6
Drive stops without overshoot by switching off I-amplification of the speed controller with $N_{comm} < MINRPM$ (A03)	< 4 >	< 0 >	I-amplification of the speed controller is always active!	3.7
Slave mode: Voltage at analogue input E1/E2 ( X4 ) is interpreted as torque command value	< 8 >	< 0 >	Speed control mode: analogue input E1/E2 ( X4 ) supports speed default	3.17
Switching to analogue input M: $10 V = \text{value of LOAD LIM ( \% or kW )}$	< 16 >	< 0 >	Analogue output M cannot be switched	3.10.1
Torque limitation via voltage at analogue input $E3/E4 ( X4 ) : 10V = 100\% M_{comm}$	< 32 >	< 0 >	No torque limitation exceeding voltage level	3.9
Spindle positioning with homing switch on the spindle	< 64 >	< 0 >	Spindle positioning without homing switch on spindle	3.6.3
Spindle positioning counter specification in A06: if A06 = <16> → affect of A06 = <0> if A06 = <0> → affect of A06 = <16>	< 128 >	< 0 >	Spindle positioning as specified in A06 ( A06 = <16> or <0> )	3.6.1
Only with RAC 2.2 and RAC 3.1 with optional additional bleeder: with power failure, braking via the NC controller	< 256 >	< 0 >	Only with RAC 2.2 and RAC 3.1 with optional additional bleeder: braking during power failure	3.19
Regardless of speed command value, signal output "N < MIN" goes to 1, if motor speed is less than MIN RPM (A03)	< 512 >	< 0 >	If speed command value and motor speed are below MIN RPM then signal output "N < MIN" goes to 1	3.3

 Additions list!
 Fkt-TabellePQ

Figure 102: Function table for parameter PQ-FUNCT (PQRS 16)

### 5.3 Motor Parameters (M Parameters)

The motor parameter values are set at the factory and guarantee the characteristics that are specified for the drive (motor controller programming module).

The M parameter values may only be changed by trained personnel. The drive could otherwise be damaged. An exception is the MOTFUNCT parameter in drives with RAC.

Parameter	Designation	Function	See section	Value range or value
M01	POLES	pole number of the motor		2,4,6,8
M02	FEEDBACK	feedback type		1.....4
M03	T-FILTER	tachometer filter	3.7	0.....3
M04	SLIP-LIM	slip limit is multiple of SIGN SLIP		1.0.....7.9
M05	FLUX	magnetizing current (peak value in A)		1..... $I_{type}$ (A)
M06	CURRENT	maximum motor current (peak value in A)		1..... $I_{type}$ (A)
M07	SIGNSLIP	characteristic slip of the drive		0.....300 (1/min)
M08	SIGN RPM	speed for increasing slip		100.....9999 (1/min)
M09	I-U RPM	speed for switching to voltage control		100.....9999 (1/min)
M10	SIGN VOLT	idle voltage of drive at 1500 rpm		0.....999 (V)
M11	BETA	corrective factor to adjust phase angle in field control range		0.....9.99
M12	PHI	corrective angle for transition to field control range		0.....45 ( $\alpha$ degrees)
M13	VOLT FACT	factor for load-dependent increase in voltage		0.....1.0
M14	SLIP FACT	factor for increase in slip in field control range		0.....1.0
M15	MOT FUNCT	see function table for M15		$\Sigma < >$
M16	PHI FACT	factor for transition to basic speed range in field control range		0.....9.99

 Parameter protocol!

Para-Motor

Figure 103: Overview of motor parameter (M)

## 5. Overview of Parameters

Function	Relevant summand		Function	See section
Parameter VOLT FACT ( M13 ) is effective	< 1 >	< 0 >	Parameter VOLT FACT ( M13 ) is not effective (standard voltage rise is active)	
Parameter SLIP FACT ( M14 ) is effective	< 2 >	< 0 >	Parameter SLIP FACT ( M14 ) is not effective (standard slip rise is active)	
Voltage amplitude in DA converter is being limited to 7V in the field control range	< 4 >	< 0 >	amplitude of voltage at DA converter is not being limited	
Voltage amplitude in DA converter is being limited in the field control range: idle: 7V acceleration: 7V + Δ U deceleration: 7V + ΔU/2	< 8 >	< 0 >	amplitude of voltage at DA converter is not being limited	
as with < 8 > but: braking: 7V + ΔU	< 12 >	< 0 >	amplitude of voltage at DA converter is not being limited	
with RAC 2.2 and RAC 3.1only d.c. dynamic braking with power failure	< 16 >	< 0 >	no d.c. braking with mains failure	3.19
with RAC 2.2 - 250: cycle time 565 μs withKDA/TDA: twice the back-up output of the voltage	< 32 >	< 0 >	with RAC 2.2 - 250: cycle time 600 μs	
With water-cooled motors: greater increase in slip	< 64 >	< 0 >	normal slip increase	

 Additions list !
 Fkt-TableM15

Figure 104: Function table for parameter MOTFUNCT (M15)

**Note:**

The user should only change the existing value in the MOTFUNCT parameter by the summand <16>. Please consult Indramat before changing the sum ( $\sum \langle \rangle$ )!

Possible error message: FEEDBACK

Cause:

- Wrong value in FEEDBACK parameter (M02). The existing motor feedback type requires a different parameter value.
- Faulty or incorrect feedback cable.

Remedy:

- Set a parameter value in M02 that corresponds to the feedback type of the motor.
- Repair or replace feedback cable.

Note:

In 2AD motors, the feedback type can be read directly from the type designation of the motor (see type code field "motor feedback").

In the case of 1MB motors (spindle motors), the feedback type cannot be obtained from the type designation as the motor feedback is fitted separately on the spindle. Only three and four can be parameter values.

Values for the FEEDBACK parameter

Parameter	Designation	Function	Value range or value
M02	FEEDBACK	Typ 1 - incremental encoder with a resolution of 1024	1
		Typ 3 - high-resolution INDRAMAT encoder with 256 teeth, 125 mm dia.	3
		Typ 4 - high-resolution INDRAMAT encoder with 512 teeth, 256 mm dia.	4
		Typ 2 - incremental encoder with a resolution of 4096	2

 Parameter protocol ! Para-M03

Figure 105: Correlation between feedback type and parameter value M02



**Interchanging feedback types 3 and 4 can damage the drive!**

### 5.4 Parameter Protocol and Additions List

Both the parameter values and the drive data can easily be compiled and fixed with the use of the parameter protocol.

The values at time of delivery (parameter list is enclosed with the AS programming module!) can be recorded together with the user-specific values matched to the machine. The permissible value range is set in the parameter protocol.

The parameter protocol is supplemented to the functional parameters A05, A06 and PQRS 16 with the use of an additions list. This list can be used to set the summands (<summand>), with comment, needed for the functions. The sum is then transferred to the parameter protocol.

## 5. Overview of Parameters

### PARAMETER PROTOCOL

Motor: \_\_\_\_\_

Software: \_\_\_\_\_

Controller: \_\_\_\_\_

Checksum: \_\_\_\_\_

Prog. module: \_\_\_\_\_

Date: \_\_\_\_\_

A Parameters									
Design.	Parameter number	current value	value at delivery	value range	Design.	Parameter number	current value	value at delivery	value range
MAX RPM	A01			1.....24000 (1/min)	LIMIT 2	A13			1.....24000 (1/min)
CMD VOLT	A02			6.....10 (V)	LIMIT 3	A14			1.....24000 (1/min)
MIN RPM	A03			1.....999 (1/min)	LIMIT 4	A15			1.....24000 (1/min)
MAX DEF	A04			1.....999 (1/min)	LIMIT 5	A16			1.....24000 (1/min)
FUNCT 1	A05			sum value 0.....9999 ( $\Sigma < >$ )	LIMIT 6	A17			1.....24000 (1/min)
FUNCT 2	A06			sum value 0.....9999 ( $\Sigma < >$ )	LIMIT 7	A18			1.....24000 (1/min)
OFFSET	A07			0.....359.9 (° deg.)	BAUDRATE	A19			see sect. 5.1, Fig. 97
POS 1	A08			0.....359.9 (° deg.)	OSCI RPM	A20			1.....200 (1/min)
POS 2	A09			0.....359.9 (° deg.)	MAXTEMP	A21			40...155 (°C)
POS 3	A10			0.....359.9 (° deg.)	FUNCT 3	A22			( $\Sigma < >$ ) see ADD. LIST
ENCODER	A11			see sect. 5.1, Fig. 97					
LIMIT 1	A12			1.....24000 (1/min)					

P Parameters				Q Parameters			R Parameters			S Parameters			
Design.	Parameter number	current value	value at delivery	Parameter number	current value	value at delivery	Parameter number	current value	value at delivery	Parameter number	current value	value at delivery	Value range
RAMP 1	P01			Q01			R01			S01			0.....999 (rad/s <sup>2</sup> )
RPM 1	P02			Q02			R02			S02			0.....24000 (1/min)
RAMP 2	P03			Q03			R03			S03			0.....999 (rad/s <sup>2</sup> )
RPM 2	P04			Q04			R04			S04			0.....24000 (1/min)
RAMP 3	P05			Q05			R05			S05			0.....999 (rad/s <sup>2</sup> )
MD-RED	P06			Q06			R06			S06			1.....99 (1/min)
P-GAIN 1	P07			Q07			R07			S07			0.....20.0
I-GAIN 1	P08			Q08			R08			S08			0.....20.0
GAIN RPM	P09			Q09			R09			S09			0.....9999 (1/min)
P-GAIN 2	P10			Q10			R10			S10			0.....9.99
I-GAIN 2	P11			Q11			R11			S11			1.....9999
GEAR IN	P12			Q12			R12			S12			1.....9999
GEAR OUT	P13			Q13			R13			S13			1.....9999
G-CHANGE	P14			Q14			R14			S14			0, 1, 2
P-MAX RPM	P15			Q15			R15			S15			1.....24000 (1/min)
PQ-FUNCT	P16			Q16			R16			S16			$\Sigma < >$ see ADD. LIST
POS GAIN	P17			Q17			R17			S17			0.....99.9 (1/s)
POS RPM	P18			Q18			R18			S18			1.....9999 (1/min)
LOAD LIM	P19			Q19			R19			S19			1.....99 (% or kW)
ALPHA	P20			Q20			R20			S20			0.....9.99
P-WINDOW	P21			Q21			R21			S21			0,1.....99.9 (° deg.)
IGS REF	P22			Q22			R22			S22			0.....359.9 (° deg.)
IGS OPEN	P23			Q23			R23			S23			1.....359.9 (° deg.)
IGS LINES	P24			Q24			R24			S24			1.....16383
IGS FUNCT	P25			Q25			R25			S25			$\Sigma < >$ see ADD. LIST
SYNC MODE	P26			Q26			R26			S26			$\Sigma < >$ see ADD. LIST
KV-SYNC	P27			Q27			R27			S27			0.....99.9 (1/s)
S-WINDOW	P28			Q28			R28			S28			0,1.....99.9 (° deg.)
SMOOTH	P29			Q29			R29			S29			_____
SYNC OFF	P30			Q30			R30			S30			0.....359.9 (° deg.)

M Parameters											
Design.	Parameter number	state at delivery	Parameter number	state at delivery	value range	Design.	Parameter number	state at delivery	Parameter number	state at delivery	value range
POLES	M01		M21		2, 4, 6, 8	VOLT FACT	M13		M33		0.....1.0
FEEDBACK	M02		M22		1.....4	SLIP FACT	M14		M34		0.....1.0
T-FILTER	M03		M23		0.....3	MOT FUNCT	M15		M35		$\Sigma < >$ see ADD. LIST
SLIP LIM	M04		M24		1.0.....7.9	PHI FACT	M16		M36		0.....9.99
FLUX	M05		M25		1..... <sub>type</sub> (A)	CONTRTYP	M17				3.050.....8.400
CURRENT	M06		M26		1..... <sub>type</sub> (A)						
SIGNSLIP	M07		M27		0.....300 (1/min)						
SIGN RPM	M08		M28		100.....9999 (1/min)	OFFSET 2	M20				0.....359.9 (° deg.)
I-U RPM	M09		M29		100.....9999 (1/min)						
SIGN VOLT	M10		M30		0.....999 (V)						
BETA	M11		M31		0.....9.99						
PHI	M12		M32		0.....45 (° deg.)						

Parameter-Blatt2

**ADDITIONS LIST for the FUNCT Parameters for the Parameter Protocol**

Motor: \_\_\_\_\_ Software: \_\_\_\_\_

Controller: \_\_\_\_\_ Checksum: \_\_\_\_\_

Prog. module: \_\_\_\_\_ Date: \_\_\_\_\_

<p><b>A05</b> FUNCT 1: Comment:</p> <p>&lt; &gt; _____</p> <p>&lt; &gt; _____</p> <p>&lt; &gt; _____</p> <p>&lt; &gt; _____</p> <p>&lt; &gt; _____</p> <p>&lt; &gt; _____</p> <p>&lt; &gt; _____</p> <p>&lt; &gt; _____</p> <p>&lt; &gt; _____</p> <p>&lt; &gt; _____</p> <p>+ &lt; &gt; _____</p> <hr/> <p>Σ &lt; &gt; =</p>	<p><b>A06</b> FUNCT 2: Comment:</p> <p>&lt; &gt; _____</p> <p>&lt; &gt; _____</p> <p>&lt; &gt; _____</p> <p>&lt; &gt; _____</p> <p>&lt; &gt; _____</p> <p>&lt; &gt; _____</p> <p>&lt; &gt; _____</p> <p>&lt; &gt; _____</p> <p>&lt; &gt; _____</p> <p>&lt; &gt; _____</p> <p>+ &lt; &gt; _____</p> <hr/> <p>Σ &lt; &gt; =</p>	<p><b>A06</b> FUNCT 2: Comment:</p> <p>&lt; &gt; _____</p> <p>&lt; &gt; _____</p> <p>&lt; &gt; _____</p> <p>&lt; &gt; _____</p> <p>&lt; &gt; _____</p> <p>&lt; &gt; _____</p> <p>&lt; &gt; _____</p> <p>&lt; &gt; _____</p> <p>&lt; &gt; _____</p> <p>&lt; &gt; _____</p> <p>+ &lt; &gt; _____</p> <hr/> <p>Σ &lt; &gt; =</p>
---	---	---

<p><b>P16</b> PQ-FUNCT: Comment:</p> <p>&lt; &gt; _____</p> <p>&lt; &gt; _____</p> <p>&lt; &gt; _____</p> <p>&lt; &gt; _____</p> <p>&lt; &gt; _____</p> <p>+ &lt; &gt; _____</p> <hr/> <p>Σ &lt; &gt; =</p>	<p><b>Q16</b> PQ-FUNCT: Comment:</p> <p>&lt; &gt; _____</p> <p>&lt; &gt; _____</p> <p>&lt; &gt; _____</p> <p>&lt; &gt; _____</p> <p>&lt; &gt; _____</p> <p>+ &lt; &gt; _____</p> <hr/> <p>Σ &lt; &gt; =</p>	<p><b>R16</b> PQ-FUNCT: Comment:</p> <p>&lt; &gt; _____</p> <p>&lt; &gt; _____</p> <p>&lt; &gt; _____</p> <p>&lt; &gt; _____</p> <p>&lt; &gt; _____</p> <p>+ &lt; &gt; _____</p> <hr/> <p>Σ &lt; &gt; =</p>	<p><b>S16</b> PQ-FUNCT: Comment:</p> <p>&lt; &gt; _____</p> <p>&lt; &gt; _____</p> <p>&lt; &gt; _____</p> <p>&lt; &gt; _____</p> <p>&lt; &gt; _____</p> <p>+ &lt; &gt; _____</p> <hr/> <p>Σ &lt; &gt; =</p>
---	---	---	---

<p><b>P25</b> IGS-FUNCT: Comment:</p> <p>&lt; &gt; _____</p> <p>&lt; &gt; _____</p> <p>&lt; &gt; _____</p> <p>&lt; &gt; _____</p> <p>&lt; &gt; _____</p> <p>+ &lt; &gt; _____</p> <hr/> <p>Σ &lt; &gt; =</p>	<p><b>Q25</b> IGS-FUNCT: Comment:</p> <p>&lt; &gt; _____</p> <p>&lt; &gt; _____</p> <p>&lt; &gt; _____</p> <p>&lt; &gt; _____</p> <p>&lt; &gt; _____</p> <p>+ &lt; &gt; _____</p> <hr/> <p>Σ &lt; &gt; =</p>	<p><b>R25</b> IGS-FUNCT: Comment:</p> <p>&lt; &gt; _____</p> <p>&lt; &gt; _____</p> <p>&lt; &gt; _____</p> <p>&lt; &gt; _____</p> <p>&lt; &gt; _____</p> <p>+ &lt; &gt; _____</p> <hr/> <p>Σ &lt; &gt; =</p>	<p><b>S25</b> IGS-FUNCT: Comment:</p> <p>&lt; &gt; _____</p> <p>&lt; &gt; _____</p> <p>&lt; &gt; _____</p> <p>&lt; &gt; _____</p> <p>&lt; &gt; _____</p> <p>+ &lt; &gt; _____</p> <hr/> <p>Σ &lt; &gt; =</p>
--	--	--	--

<p><b>P26</b> SYNCMODE:</p> <p>&lt; &gt; _____</p> <p>&lt; &gt; _____</p> <p>&lt; &gt; _____</p> <p>&lt; &gt; _____</p> <p>&lt; &gt; _____</p> <p>+ &lt; &gt; _____</p> <hr/> <p>Σ &lt; &gt; =</p>	<p><b>Q26</b> SYNCMODE:</p> <p>&lt; &gt; _____</p> <p>&lt; &gt; _____</p> <p>&lt; &gt; _____</p> <p>&lt; &gt; _____</p> <p>&lt; &gt; _____</p> <p>+ &lt; &gt; _____</p> <hr/> <p>Σ &lt; &gt; =</p>	<p><b>R26</b> SYNCMODE:</p> <p>&lt; &gt; _____</p> <p>&lt; &gt; _____</p> <p>&lt; &gt; _____</p> <p>&lt; &gt; _____</p> <p>&lt; &gt; _____</p> <p>+ &lt; &gt; _____</p> <hr/> <p>Σ &lt; &gt; =</p>	<p><b>S26</b> SYNCMODE:</p> <p>&lt; &gt; _____</p> <p>&lt; &gt; _____</p> <p>&lt; &gt; _____</p> <p>&lt; &gt; _____</p> <p>&lt; &gt; _____</p> <p>+ &lt; &gt; _____</p> <hr/> <p>Σ &lt; &gt; =</p>
--	--	--	--

<p><b>M15</b> MOT FUNCT</p> <p>Comment:</p> <p>..... value input by manufacturer</p> <p>&lt; &gt; possibly &lt; 16 &gt; for DC bus dynamic braking</p> <p>+ &lt; &gt; possible &lt; 32 &gt; for cycle time/support index</p>	<p><b>M35</b> MOT FUNCT</p> <p>Comment:</p> <p>..... value input by manufacturer</p> <p>&lt; &gt; possibly &lt; 16 &gt; for DC bus dynamic braking</p> <p>+ &lt; &gt; possible &lt; 32 &gt; for cycle time/support index</p>
--	--

## 6. Interfaces for the NC Controller and Feedback

### 6.1 Controller Inputs, Signal and Analogue Outputs, Bb Contact

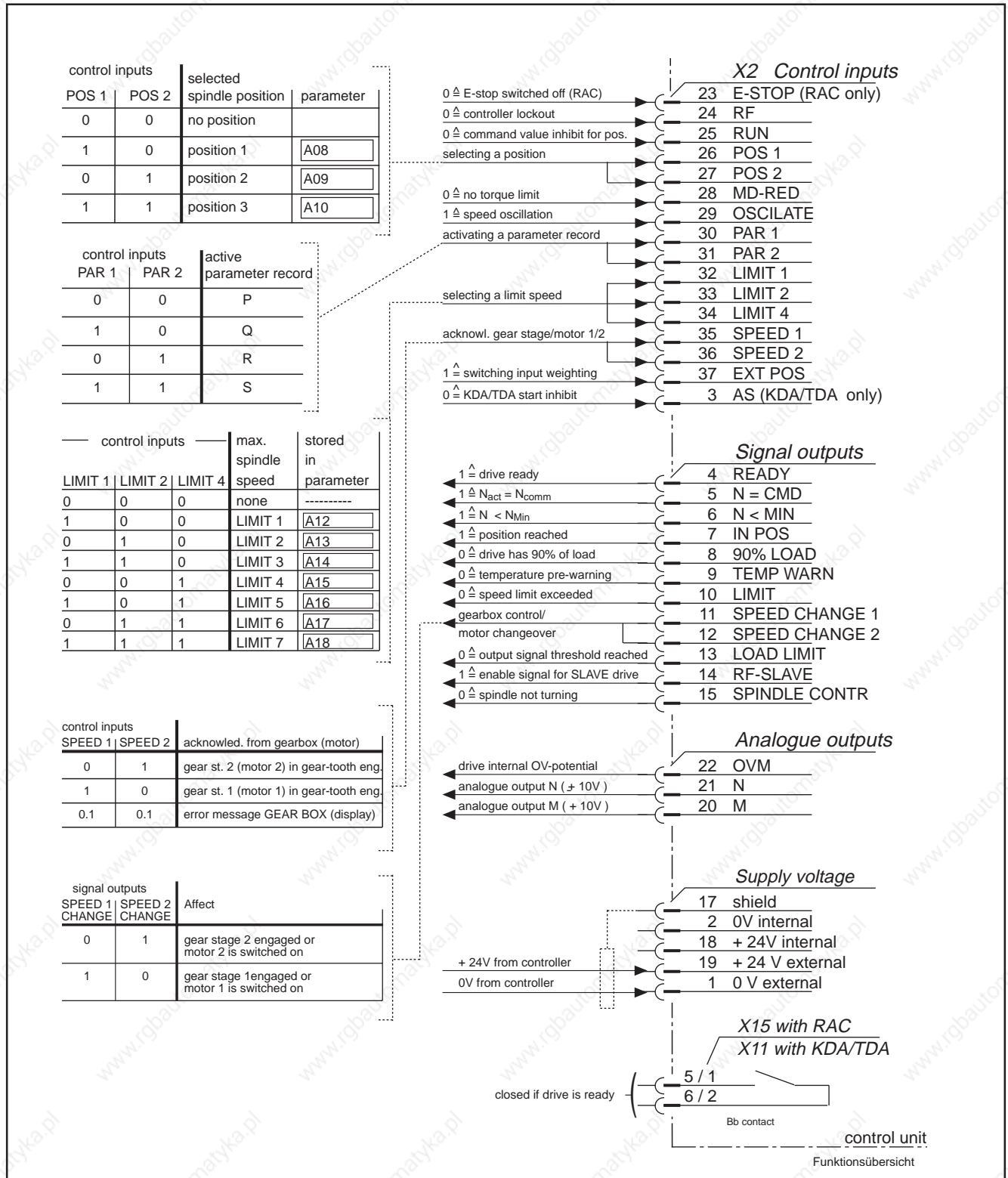

Figure 106: Function overview of controller inputs, signal and analogue outputs

## 6. Interfaces for the NC controller and feedback

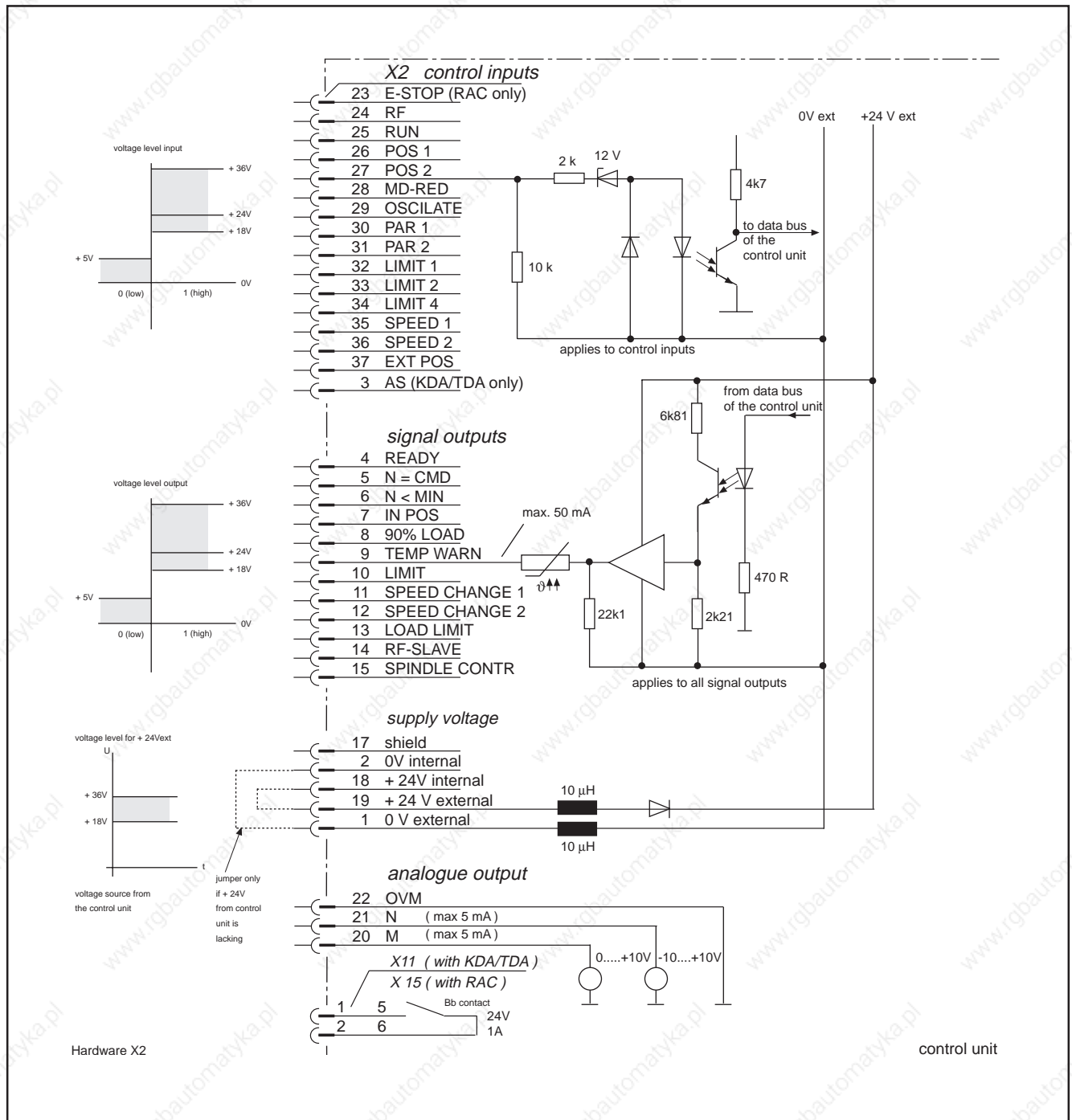

Figure 107: Hardware of the controller inputs, signal and analogue outputs (X2)

The inputs and outputs are electrically isolated. If no +24V/0V are available from the controller to supply the outputs, link terminals 18 and 19 and terminals 1 and 2.

## 6.2 Analogue Speed Command Value •10V (option)

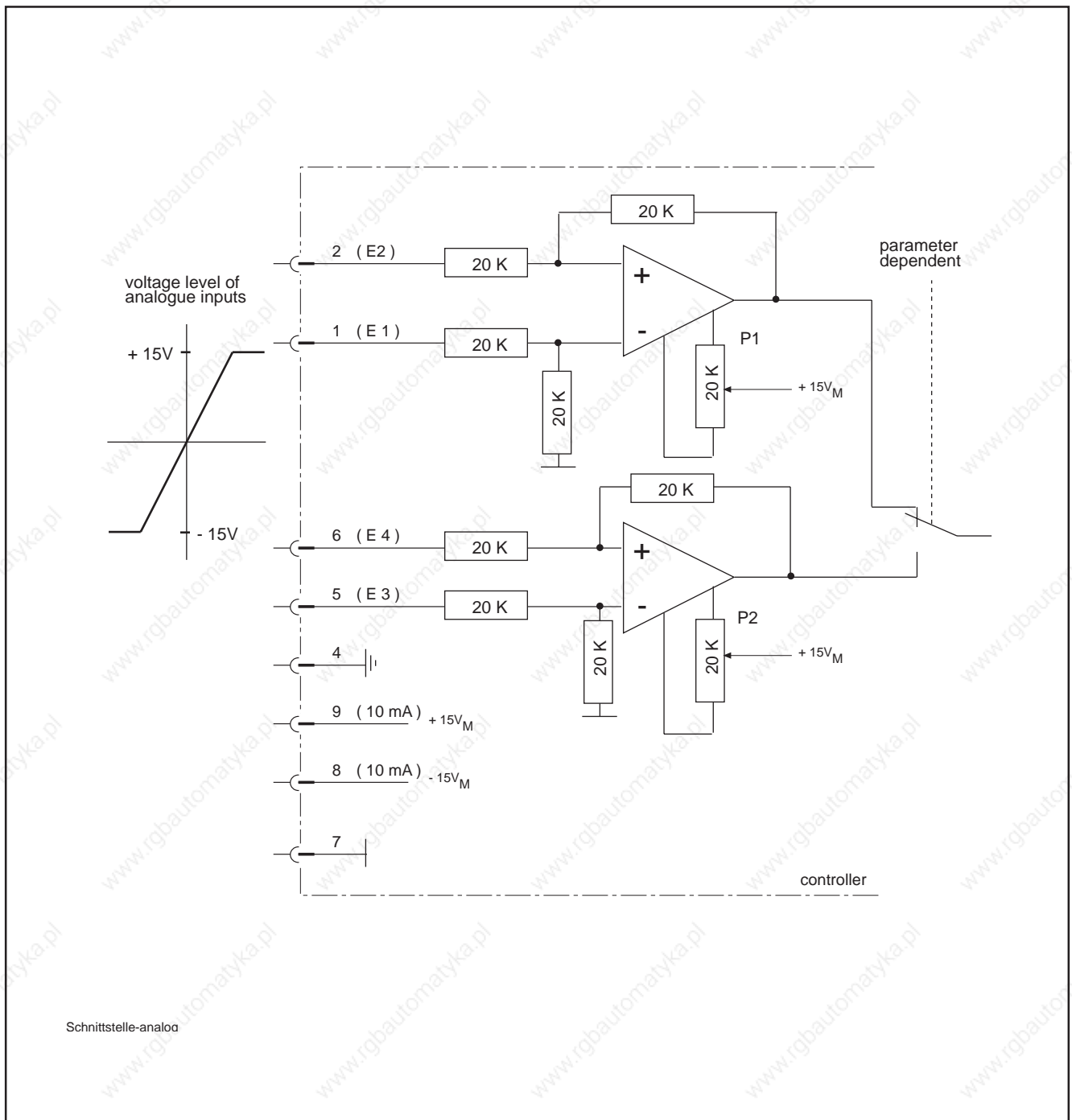

Figure 108: Interface for analogue speed command value

Analogue inputs E1/E2 are configured as differential inputs. Potentiometers P2 and P2 compensate drive when 0 V is applied to the respective analogue input. They are located to the right and left of plug terminal strip X4.

Identification in the "speed command value" type code field is: A

### 6.3 Digital Speed Command Value (option)

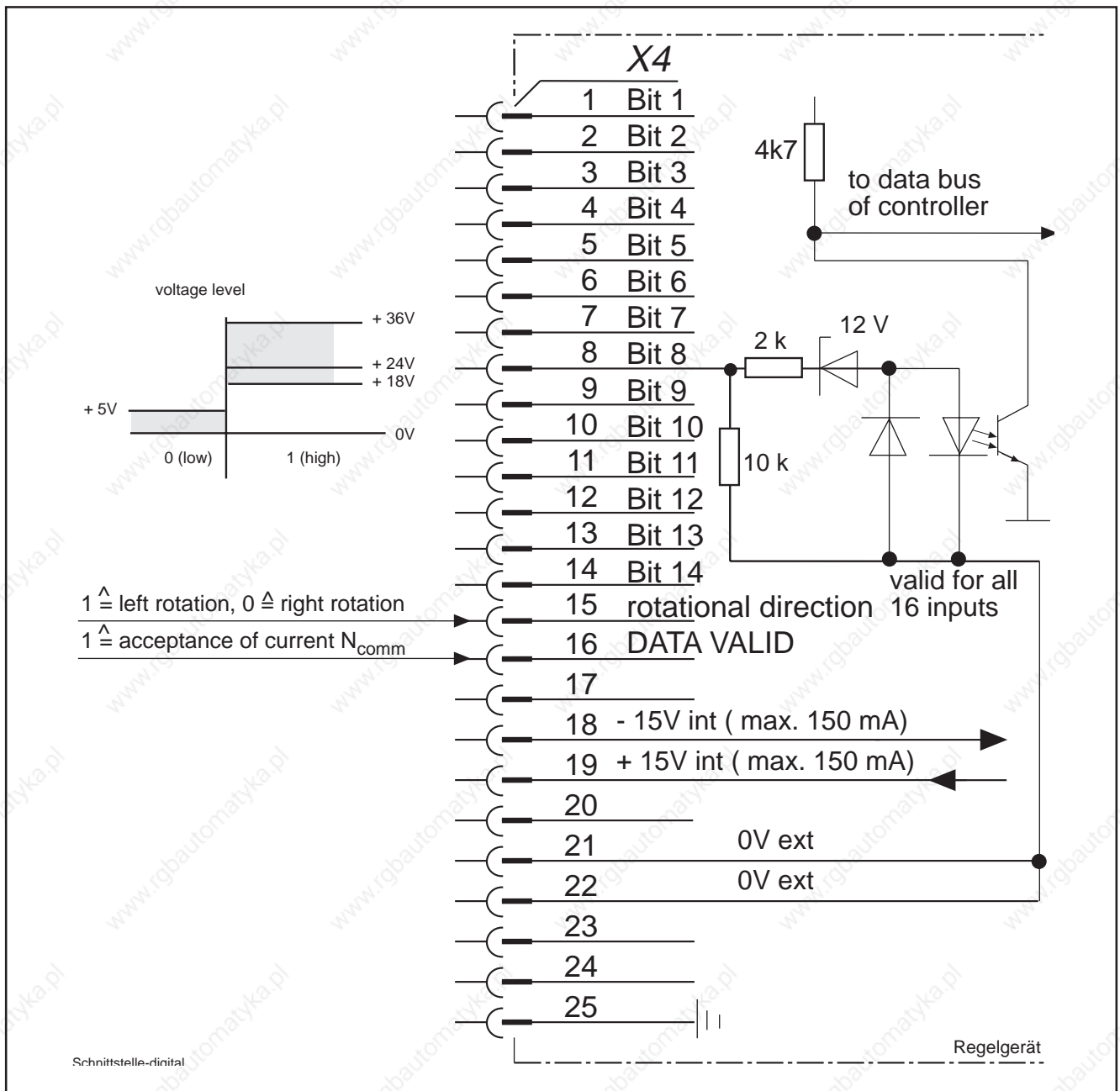

Figure 109: Interface for digital speed command value (optional)

The inputs are electrically isolated. If no +24V/0 V are available from the controller to drive the inputs, link terminals 18 and 21.

Terminal 19 is then 1 (high) and terminal 18 is 0 (low). The controller must then generate the bit pattern for the position command value via potential-free contacts.



**If the internal  $\pm 15V$  is used, the total loading must not exceed 150 mA. A digital position input above  $\pm 15V$  is also not possible!**

### 6.4 SERCOS Interface (option)

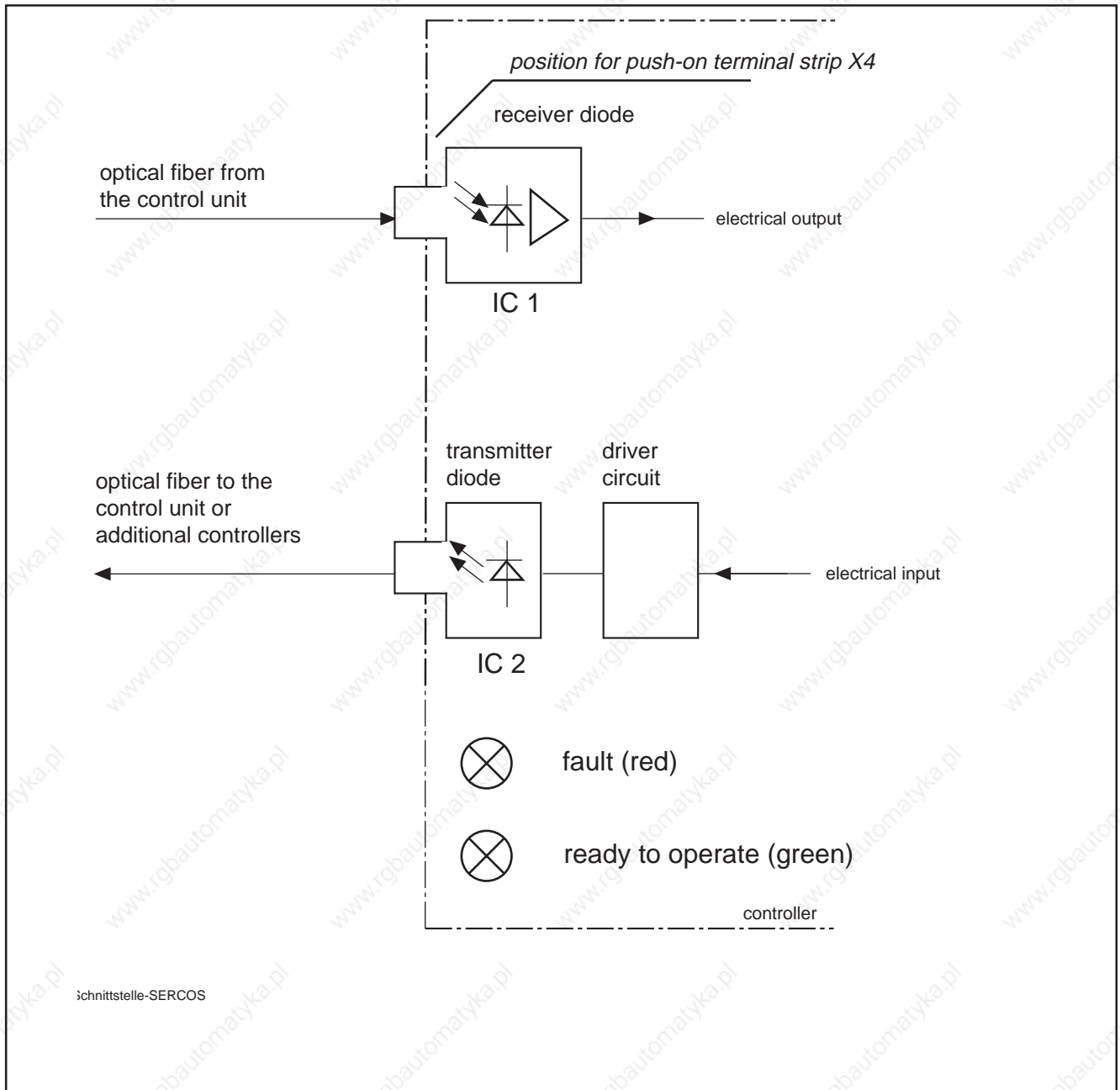

Figure 110: Interface for SERCOS interface (optional)

Identification in "speed command value" type code field: L

## 6.5 Digital Position Command Value (option)

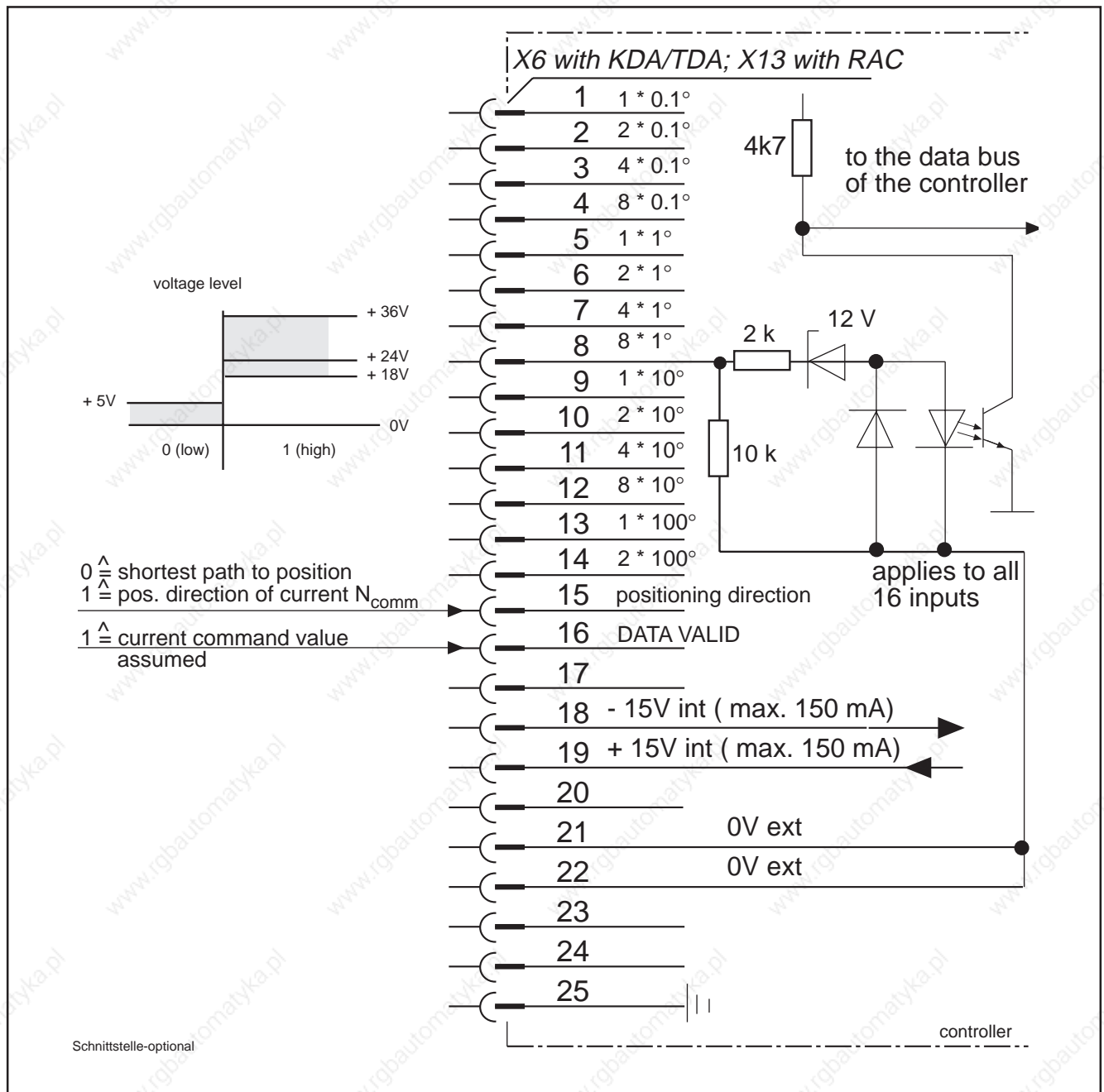

Figure 111: Interface for digital position command value (optional)

The inputs are electrically isolated. If no +24 V/0V are available from the controller to drive the inputs, link terminals 18 and 21.

Terminal 19 is then 1 (high) and terminal 18 is 0 (low). The controller must then generate the bit pattern for the position command value via potential-free contacts.

Identification in "additional interfaces" type code field: D



**If the internal  $\pm 15V$  is used, the total loading must not exceed 150mA. A digital position input above  $\pm 15V$  is also not possible!**

## 6.6 Incremental Encoder Output (option)

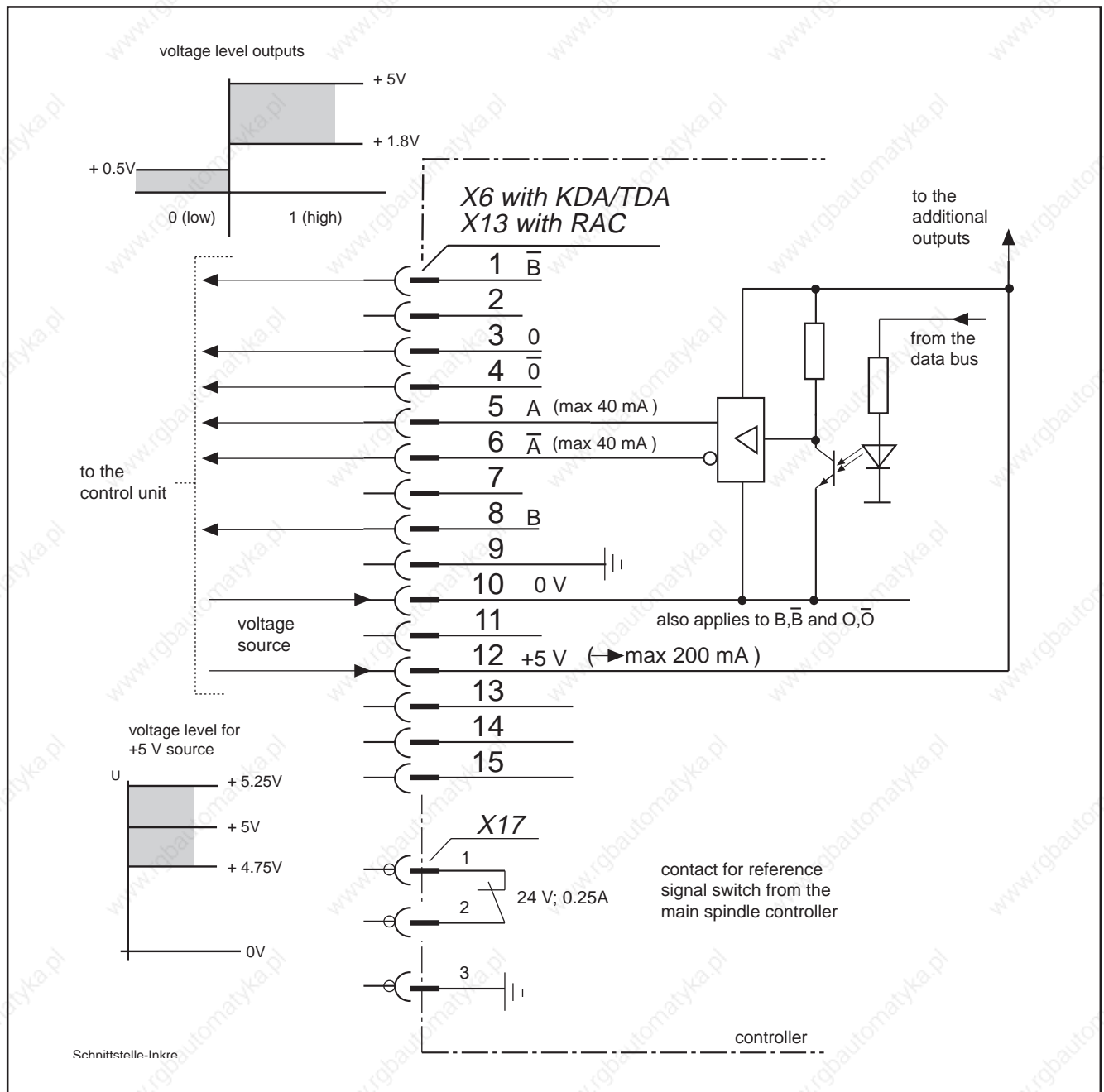

Figure 112: Interface for incremental encoder output (optional)

The control unit supplies incremental encoder-compatible signals to the controller for displacement measurement. For this option, the motor must be fitted with high-resolution feedback (feedback type 3 or 4).

The outputs are electrically isolated. The controller must provide the  $+5V$  supply.

Identification in "additional interfaces" type code field: I

## 6.7 Serial Interface (option)

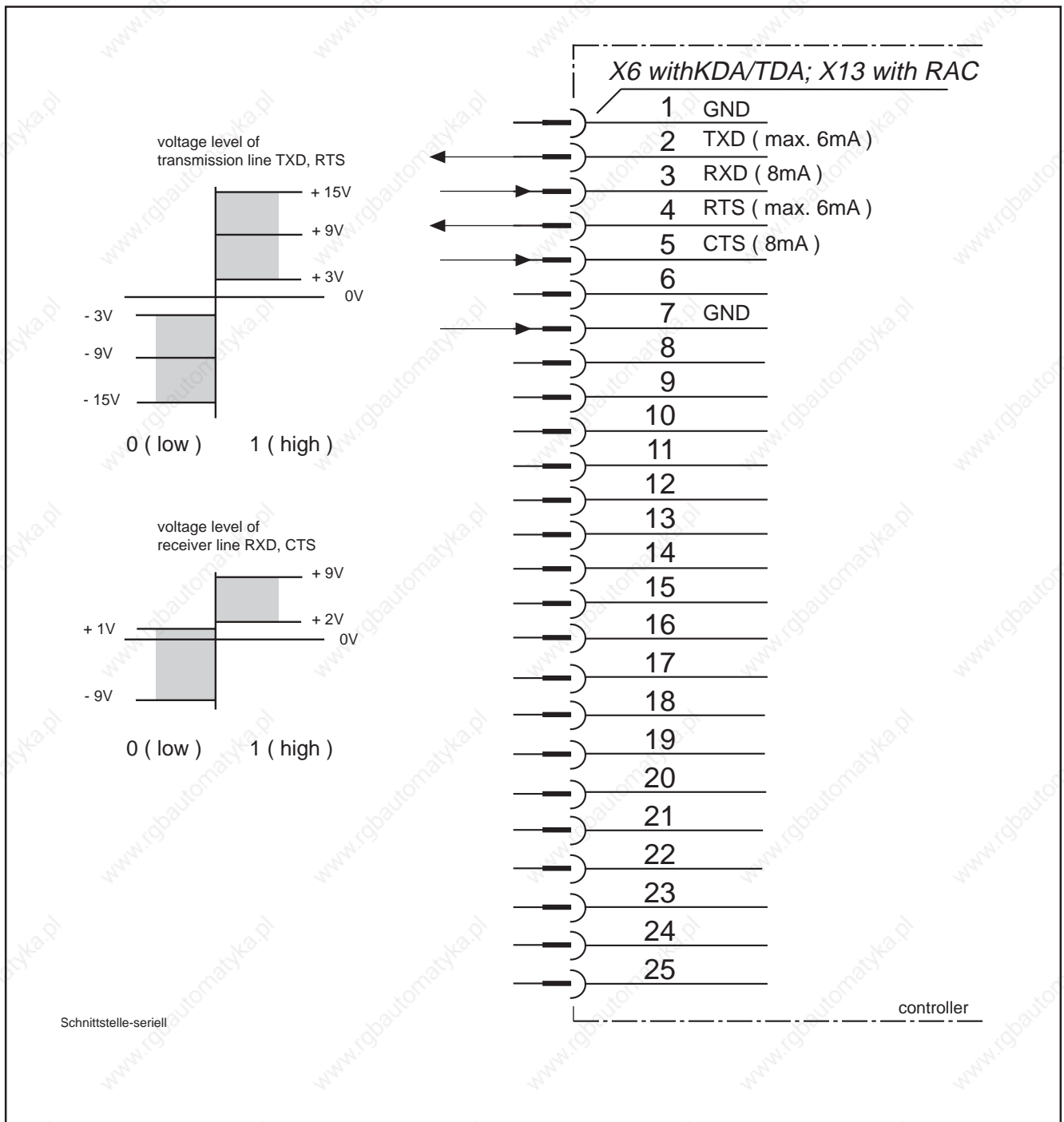

Figure 113: Serial interface RS 232 C (optional)

The serial interface is not potential-free but can be correctly run from any input device (PC or something similar) with an RS 232 C interface.

Identification in "additional interfaces" type code field: S

### 6.8 Motor Feedback Connection

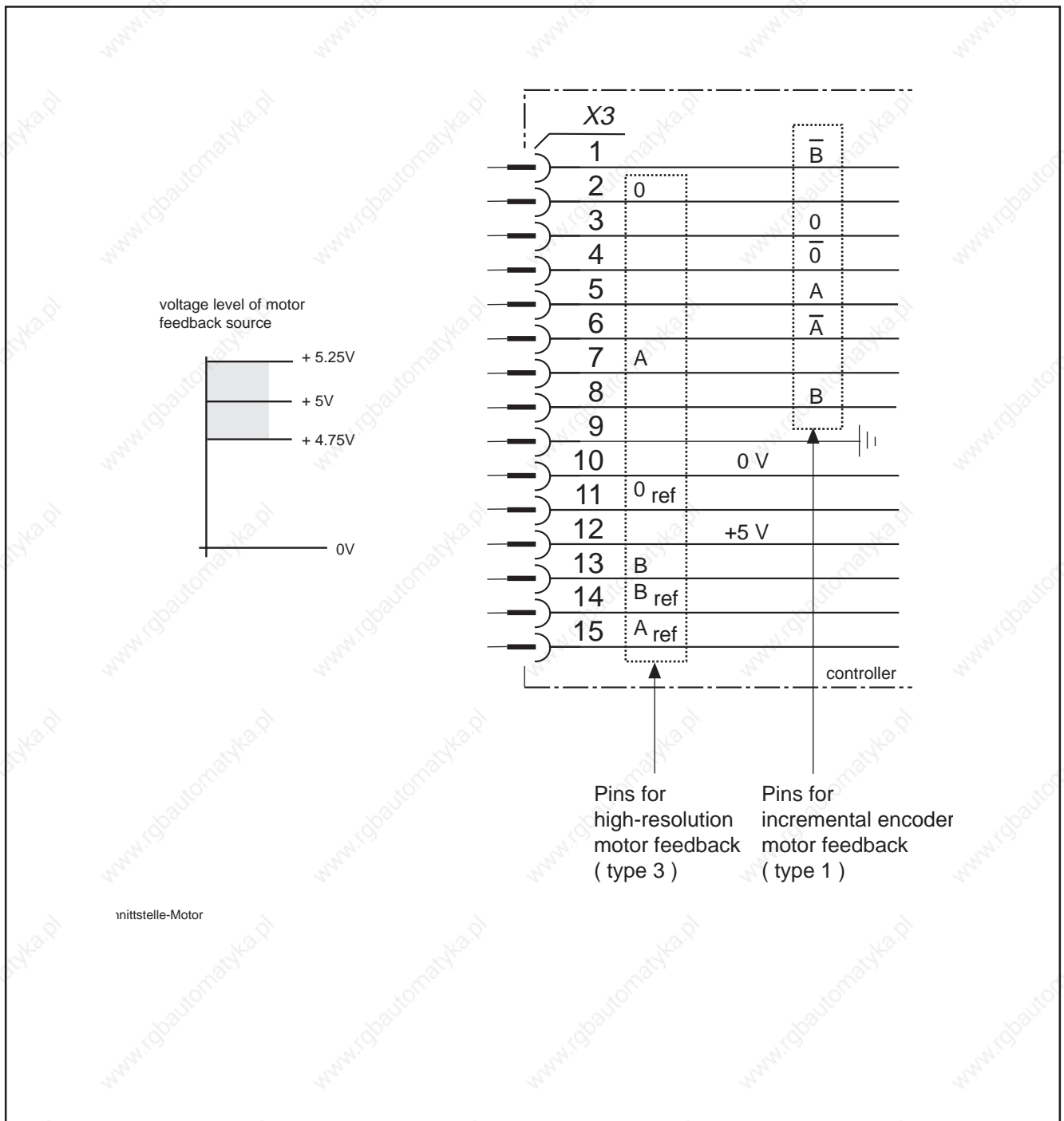

Figure 114: Motor feedback interface

Plug terminal strip X3 has pins for the high-resolution motor feedback (type 3) as well as for pins for the incremental encoder motor feedback (type 1).

## 6.9 Additional Encoder Input (option)

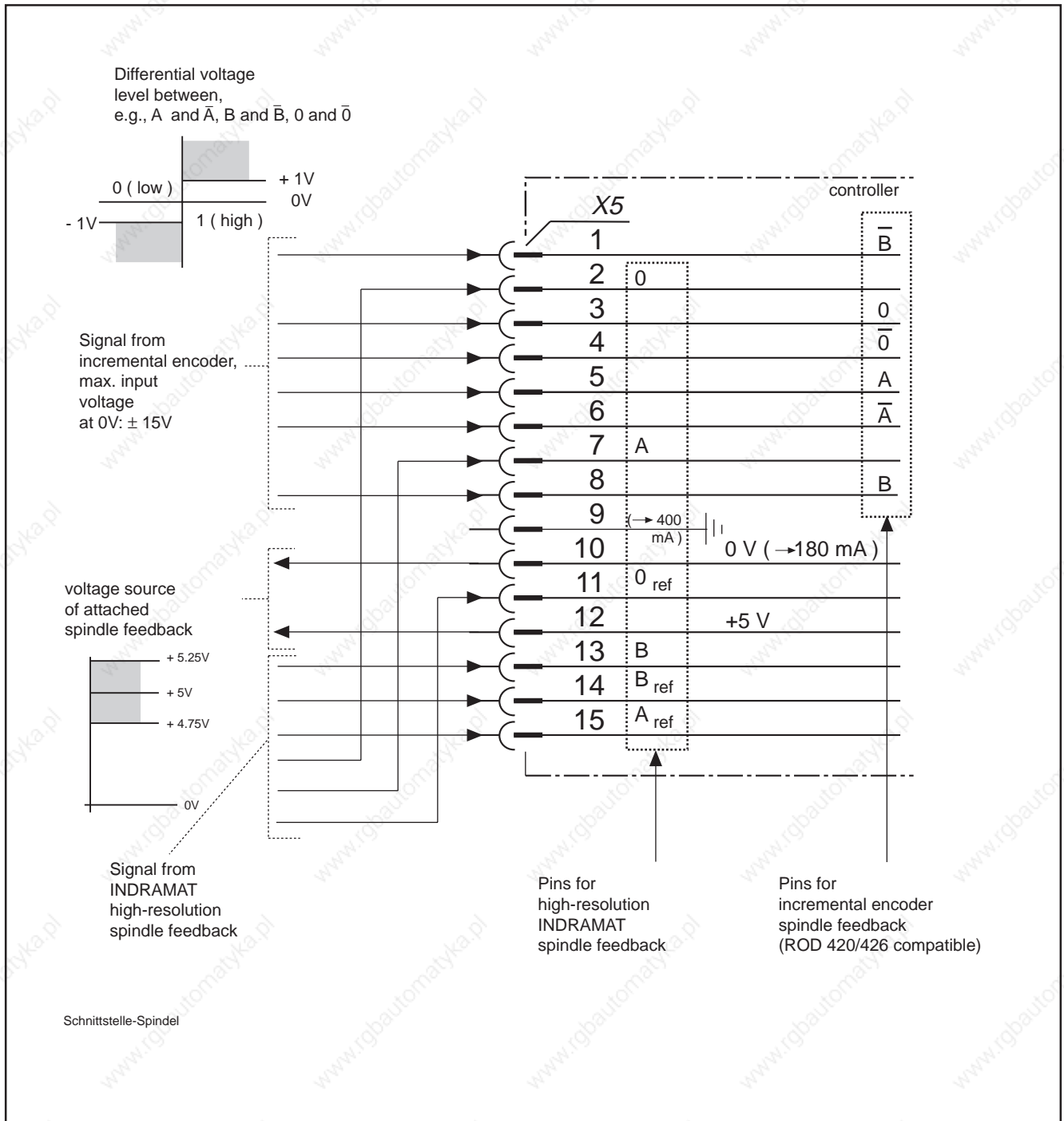

Figure 115: Interface for additional encoder input (optional)

The control unit supplies the associated spindle feedback with +5V. The inputs AA, BB and OO are differential inputs.

Plug terminal strip X5 has pins for the Indramat high-resolution spindle feedback as well as for pins for incremental encoders used as spindle feedback (compatible with ROD 420 or ROD 426).

**Only one of the quoted feedback types can be connected!**

Identification in "second encoder input" type code field: P

## 7. Index

### Symbole

< >	137
±24 V	37
ΔN in rpm	47
Δt in seconds	47
„E-Stop“ control input	37
„MASTER“	36
„MAX DEV“	44
„N * NCMD“	44
„NO TEMP“	25
„SLAVE“	36
„TEMP WARN“	25
0	136
0 V	37
0.001/i angular degrees	59
0.1/i angular degrees	59
1	136
1MB	136
1MB frameless spindle motor	64
2AD	136
2X SIM	105
3.12 Maximum Spindle Speed	75
3600 optional selectable spindle positions	50
3600 spindle positions	53, 54
"4B13 OFF"	36
"90% LOAD"	68

### A

A Parameters	106
A04	44
A06	53
A1, A2, A3	136
"accept key"	34
Accept key	29
Acknowledging maximum speeds	76
Additional bleeder	93
Additional interface	60
ADW	137
ADW2	40, 100
Aligning the tool	50
Allgemeine Parameter (A) im Überblick	106
ALPHA parameter	109
Analogausgang für Antriebsauslastung	69
Analogue command value	18
Analogue differential input (X4)	78
Analogue inputs E1/E2	118
Analogue output M	72
Analogue Output N	29
Analogue Speed Command Value (option)	38
Angle amin	57
Anpassung des Slave auf den Masterantrieb	90

**Anschlußplan**

- für Getriebeumschaltung 82
- für Master-Slave-Antrieb mit KDA/TDA 91
- für Master-Slave-Antrieb mit RAC 91
- für Zwei-Motoren-Umschaltung 87

**Antriebsauslastung**

- Analoger Ausgang für 69
- AS programming module 31, 35
- AS.. 136
- Assignment of gear stage 79
- Automatic speed change 77
- Auxiliary d.c. contactors 79

**B**

- Back-up copy 35
- Balance holes 50
- Balluf BES 516 series 58
- Basic Data for Spindle Positioning 52
- "BASISPART" 36
- "Bb" 37
- Bb 136
- Bb contact 20
- "Bb" potential-free contact 37
- Bb1 136
- Binary coded 41
- Bit pattern 42, 43
- BLEEDER 95, 100
- Bleeder monitor 94
- Bleeder monitor features of the RAC 2.2 95
- Blower operation 20
- Braking at maximum torque 93
- Braking without overshoot 63
- Breakaway damping 45
- BS (KDA only) 100
- Bus connecting cable 20
- Bus connecting cable to additional KDA drive modul 24

**C**

- C-axis drive for lathes 38
- C-axis operation 38
- C-axis servo function 62
- CDR 136
- Change of weighting 46
- Changing the Parameters 33
- Changing the parameters 34
- Changing to another parameter record 32
- "Chatter" 22, 26
- Checking the terminals and connectors 20
- Checks with the Equipment Switched-Off 23
- Checksum 36
- Circuit breakers 25
- Clockwise 59
- CMDVOLT 66
- Command cable 24
- Command value box 18, 26
- Command value input via the NC controller 92

Command Value Smoothing 48  
Commissioning 13  
Constant power range 62  
Constant torque 62  
Constant-power range 45  
Control input 37  
Control inputs for selecting the switchable parame 62  
Control Panel 27  
Control voltage 36  
Control voltage ON 24  
Controller enabling signal 62  
Controller Functions 37  
Controller heatsink 37  
Controller inputs for C-axis functions 66  
Conversion graph 47  
Converting speed  $\Delta N$  and slope times  $\Delta t$  in RAMP 47  
Counterclockwise 59  
Cross sections of power cables 19, 24

**D**

DACFAULT 100  
"DATA VALID" 42, 43  
DATA VALID 54  
DC and AC multimeter 18  
DC braking 93  
DC bus dynamic braking 21  
DC bus voltage 21, 26  
DC-FAULT 100  
Default values 33  
Digital parallel transmission 41  
Digital Speed Command Value (option) 41  
Direct measuring system on spindle 65  
DISABLED 96  
DISABLED (KDA only) 98  
Displaying the Software Version 35  
"down" 29  
"down" key 29  
Drive diagnostics 29  
Drive "Ready" State 37  
Drive-specific motor parameter 33  
Duplicating the Parameters 35

**E**

E-STOP 92  
E-stop 46  
E-STOP (RAC only) 98  
E-stop system 92  
E1/E2 136  
E3/E4 136  
EARTH CON 100  
Earth loops 38  
Earthing arrangements 19, 23  
EEPROM 31, 36, 101  
Electrostatic charge 17

- EMERGENCY STOP 16  
EMERGENCY-STOP 92  
Encoder lines, adjustable 65  
End connector for bus connecting cable 20  
Entering position command value 54  
Error message 95  
Error messages 74, 81, 86  
EXT POS 40, 46, 66
- F**  
FAULT LED 24  
Feed enabling signal 44  
FEEDBACK 35, 101, 112  
FEEDBACK parameter (M02) 112  
Floating-point coded 41  
Floating-Point Coding 43  
FUNCT 1 63  
FUNCT 2 40, 53  
Function conversion 38, 41, 52  
Funktionstabelle zu Parameter FUNCT1 (A05) 107  
Funktionstabelle zu Parameter PQ-FUNCT (PQRS 16) 110
- G**  
G-CHANGE 86  
G-CHANGE parameters 86  
GAIN RPM 63  
GEAR BOX 101  
Gear change 44  
GEAR IN/GEAR OUT 76  
Gear reduction ratio 38  
Gear stage dependent drive optimization 80, 83  
Gear-change motor 79  
GEARBOX 81  
General data 71  
Getriebeumschaltung  
Anschlußplan für 82  
Green LED 27  
Guidelines on Protecting Equipment 17
- H**  
Hardware 117  
Heatsink pre-warning 74  
High rotational speed stiffness 65  
High-resolution motor feedback 65, 124  
HOMING 59, 98  
HOMING (does not go off after spindle rotates) 101  
Hysteresis 57
- I**  
I-U-RPM 63  
IGS 136  
IN POS 98  
Incremental encoder 60  
Incremental encoder motor feedback 124  
Incremental encoder-compatible signals 65

Indication with cold motor: 25  
Indramat high-resolution encoder 60  
Inductive proximity switch 58  
Initial Start-Up 22, 26  
INPOS 58  
Input switching 40  
Input weighting 40  
Interface for analogue speed command value 118  
Interface for digital position command value 121  
Interface for digital speed command value (optional) 119  
Interface for incremental encoder output 122  
Interface for SERCOS interface 120  
Internal command value disconnect 92  
Internal command value to zero 95  
Internal State Variables 29

**J**

J 136

**K**

KDA 136  
KDA-TYPE (Display) 104  
KDA/TDA interrupts 95  
KDA3/TDA 1 37  
KK TEMP 101  
KK WARN 102  
KKWARN 74

**L**

L+/L- 136  
L1, L2, L3 136  
LED and LCD display status signals 20  
Limiting peak torque 67  
Limiting peak torque and peak power 67  
Limiting with parameter or analogue voltage 68  
LOAD LIM 78  
LOAD LIMIT 72, 73  
Loading Operating Parameters via Serial Interface 36  
Low lathe speeds 64

**M**

M parameter values 111  
M parameters 90  
M02 35  
M03 T-filter 33  
M09 63  
M15 MOTFUNCT parameters 33  
Main drive 95  
Main spindle drive 13, 14, 15, 38  
Main Spindle Drive in Operating Mode 28  
Main Spindle Drive in Parameter Mode 31  
Main Spindle Drives with KDA or TDA 19  
Main Spindle Drives with RAC Controllers 23  
Main Spindle Speed Signals 44  
Main spindle speed signals 44

Mains failure (RAC) 93  
Mains off 46  
Mains Requirements 23  
Master 136  
Master drive data 88  
Master module 36  
Matching initial sensitivity 90  
Matching slave to master 90  
Matching to different speeds 77  
Maximum torque 62  
MAXRPM 57, 66  
MD-RED 68  
MD-RED control input 68  
Mechanical link 88  
Memory of the programming module 34  
MERCENCY-STOP circuit 92  
MIN RPM 84  
Minimum  $\geq^\circ$  57  
Minimum dwell angle 57  
MINRPM 40, 45, 63  
Modified motor parameter values 35  
Modular drive system 95  
MOT TEMP 102  
MOT WARN 102  
MOTFUNCT 112  
MOTOR 1/2 102  
Motor changeover 85, 86  
Motor feedback cable 24  
Motor feedback interface 124  
Motor standstill 45  
Motor temperature measurement 25  
Motor temperature T 21  
Motor temperaturepre-warning 74  
Motor winding 37  
Motorparameter (M) im Überblick 111  
MOTWARN 74

**N**

N \* NCMD 98  
N < Nmin 44  
N = NCMD 98  
N/C contact 26  
N<MIN 84  
N<NMIN 99  
"N=CMD" 45  
Nact  $\neq$  Ncomm 44  
NC clock times 48  
NC control unit command value to zero 96  
NC controller 38  
Nist 44  
Nist = Nsoll 44  
Nist  $\neq$  Nsoll 44  
NO 12 MHz (Display) 103  
NO 15V 103  
NO 24 VEX 103

NO 24V 103  
NO 8 MHz or NO 12 MHz 103  
NO 8V 103  
NO INPUT 40, 43, 102  
NO MAINS(RAC 3 only) 102  
NO POWER 24, 28, 98  
NO RAC 2.2 (RAC 2.1 only) 102  
NO RF 26, 98  
NO RUN 52, 98  
NO TEMP 103  
Noise immunity reasons 38  
NOPOWER 28  
Nsoll. 44  
Null of the command value input 21, 25

**O**

OFFSET 31, 53, 55, 59, 61  
OK 27  
Operating mode 27  
Operating software 35  
Operating the Controllers 27  
OSCI RPM 81, 84  
OSCILATE 99  
OSCILATE (Display) 99  
OSCILLATE 81, 84  
OSCILLATE control input 84  
OSCILLATE message 84  
Oscilloscope 29  
otor parameter values 111  
OVER VOLT (RAC only) 103

**P**

P-control 63  
P-I-GAIN 1 63  
P-I-GAIN 2 63  
P-MAXRPM 40, 66  
PARA LOST 104  
Parallel signals 41  
PARALOST 36  
Parameter checksum 31  
Parameter checksum display 31  
Parameter duplication adapter PDA 1 35  
Parameter for analogue speed command value 39  
Parameter mode 27  
Parameter records P, Q,R or S 32  
Parameter Value Quick-Check 31  
Parameters for mass-produced machines 35  
Parameters for speed command value ramps 46  
PDA 137  
PDA 1 36  
PDS 137  
Percentage torque utilization 69  
Performance features 38  
Personnel protection 45  
PHASE (RAC only) 104

Plug terminal strip X3 124  
Polarity of the torque command value 90  
POS ERROR 104  
POS ORDER 99  
POS1 52  
POS2 52  
Positionieren von Werkstücken 50  
Positioning accuracy 50, 56, 59, 60  
Positioning drive with various gear ratios 38  
Possible fault message 43, 59  
Possible fault messages 35, 36, 40  
Power and Torque Limits 67  
Power input 27  
Power level related to the machining 70  
Power output 27  
Power transformer 24  
Power transformer connection 20  
Power-down 92  
PQ FUNCT 53, 63, 66, 90, 109  
PQ-FUNCT 40, 68  
PQRS parameter 63  
Protecting Personnel 16  
Protection against overheating 74  
Providing functions 77  
Proximity switch 58

**R**

RAC 37, 136  
RAC 2.2 and RAC 4.1 23  
RAC 3.1 23  
RAM FAULT (RAC only) 104  
Ramp function 62  
Ramp-type characteristics 45  
Reading a parameter record 32  
"READY" 37  
READY 24, 26  
READY output 20  
"READY" signal 37  
"READY" signal output 37  
Red central key 29  
Red key 34, 35  
Red LED 27  
Reference point 59  
Reference switch 57, 58  
RF 62  
RF AGAIN 104  
RF control input 45  
RF control input 35  
RF-AGAIN 35  
Rising edge 59  
Rising edge of reference switch 59  
ROD 420/426 60  
Rotating pointer 36  
RPM 40  
rpm 136

RSK 136  
RSK FAULT 104  
RSKCURNT 105  
RUN 45, 52, 57

**S**

S-CIRCUIT 105  
Safety Guidelines 16  
Search speed 57  
Second command value input 65  
Second differential input 66  
Second encoder input 60  
Second encoder inputs 85  
Second proximity switch 58  
Separate source or high voltage 17  
Sequence of operations 84  
"Sercos" 60  
"SERCOS interface" option 38  
"Serial Interface" 36  
Serial interface RS 232 C 123  
Severe interference 41  
Shielded cable 58  
Shielding 20, 24  
Signal output 37  
Signal output 44, 73  
Six parameter records 32  
SLAVE 99  
Slave 136  
Slave drive data 89  
Slave programming module 36  
SPEED 1 81  
SPEED 2 81  
Speed Command Value 38  
Speed Command Value Ramps 45  
Speed command value validity 42, 43  
Speed Controller Functions 62  
Speed dependent changeovers 63  
Speed dips 68  
Speed limiting 40  
Speed limits 41  
Speed reduction stages 45, 48  
SPINDLE 105  
Spindle coasting 76  
Spindle feedback zero pulse 61  
Spindle Monitor 76  
Spindle position via motor feedback 56  
Spindle Positioning 50  
Spindle positioning accuracy 60  
Spindle positioning via Motor Feedback 57  
Spindle positioning via motor feedback 51  
Spindle positioning via Spindle Feedback 60  
Spindle reference switch 57, 58, 78  
Spindle transmitter cable 24  
Staircase changes 48  
Standard production machines 31

Starting lockout 37  
Stiffness, coupling 64  
Subminiature connectors) 18  
Summands 106, 109, 113  
"SWITCH" 36  
Switchable function parameters 78  
Switchable parameter records 68  
Switching torque-speed control 90  
System for reading the parameter records 32

**T**

TDA 136  
Temperature sensor 24  
Terminal strip X2 37  
Time period  $\Delta t$  47  
Torque build-up 62  
Torque disconnect 45  
Torque utilization related to the machining 70  
Torque value 71  
Trailing edge 59  
Transfer running 36  
Two-stage gearbox 79  
Type codes for RAC 2 140  
Type codes for RAC 3 141  
Type codes for RAC 4 142  
Type codes for AS 143  
Type codes for KDA 3 138  
Type codes for TDA 1 139

**U**

UNACCEPT 35  
Unintentional modification 33  
User parameters 33

**W**

Weighting conversion speed command value 66  
Wire break monitoring 74  
Workpiece contour 50



**X**

X-axis 64  
X12 ADW 105

**Z**

Zero velocity 62

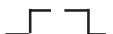
## 8. Abbreviations, Agreements, Type Codes

<i>RAC</i>	Main spindle drive controllers with 2AD and 1MB asynchronous motors with regenerative capabilities (see type codes for RAC)
<i>KDA</i>	Modular main spindle drive controller for 2AD and 1MB asynchronous motors in cold-running technology (see type codes for KDA)
<i>TDA</i>	Modular main spindle drive controller for 2AD and 1MB asynchronous motors (see type codes for TDA)
<i>AS..</i>	Programming modules for RAC, KDA and TDA drive controllers (see type codes for AS)
<i>2AD</i>	Asynchronous motor, with separate-source blower
<i>1MB</i>	Frameless spindle motor, water-cooled
<i>Bb</i>	Drive controller "ready" contact
<i>Bb1</i>	"Ready" contact on supply module
<i>E1/E2</i>	First analogue input of the main spindle controller
<i>E3/E4</i>	Second analogue input of the main spindle controller
<i>L+/L-</i>	DC bus voltage terminals (DC output)
<i>J</i>	Temperature
<i>rpm</i>	Speed in rpm
<i>IGS</i>	Incremental encoder output interface
<i>Master</i>	Master drive (speed-controlled)
<i>Slave</i>	Slave drive (speed-controlled)
<i>L1, L2, L3</i>	Mains terminals for the RAC controller
<i>A1, A2, A3</i>	Motor terminals for the controller
<i>0</i>	low = 0 V
<i>1</i>	high = +24 V
	Signal step change
	Signal state (any)
<i>RSK</i>	Board in RAC, controls mains regeneration
<i>CDR</i>	Board in controller, entails micro-processor control unit

## 8. Abbreviations, Agreements, Type Codes

---

*ADW* Interface for analogue speed command value

*PDS* Interface for digital speed command value

*PDA* Parameter duplicating adapter

< > Summand, a part of the total value for the function parameters

## 8. Abbreviations, Agreements, Type Codes

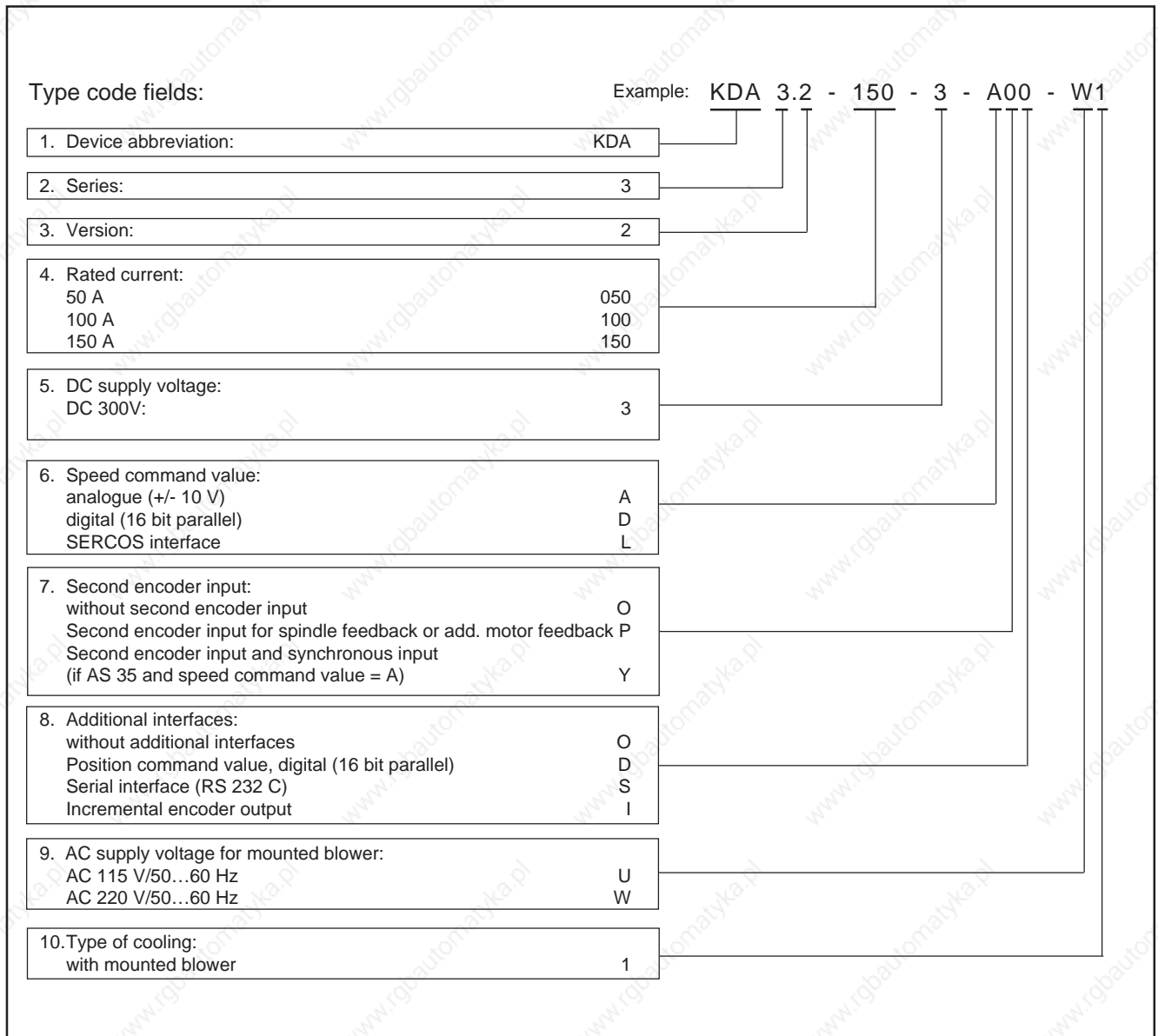

Figure 116: Type codes for KDA 3

## 8. Abbreviations, Agreements, Type Codes

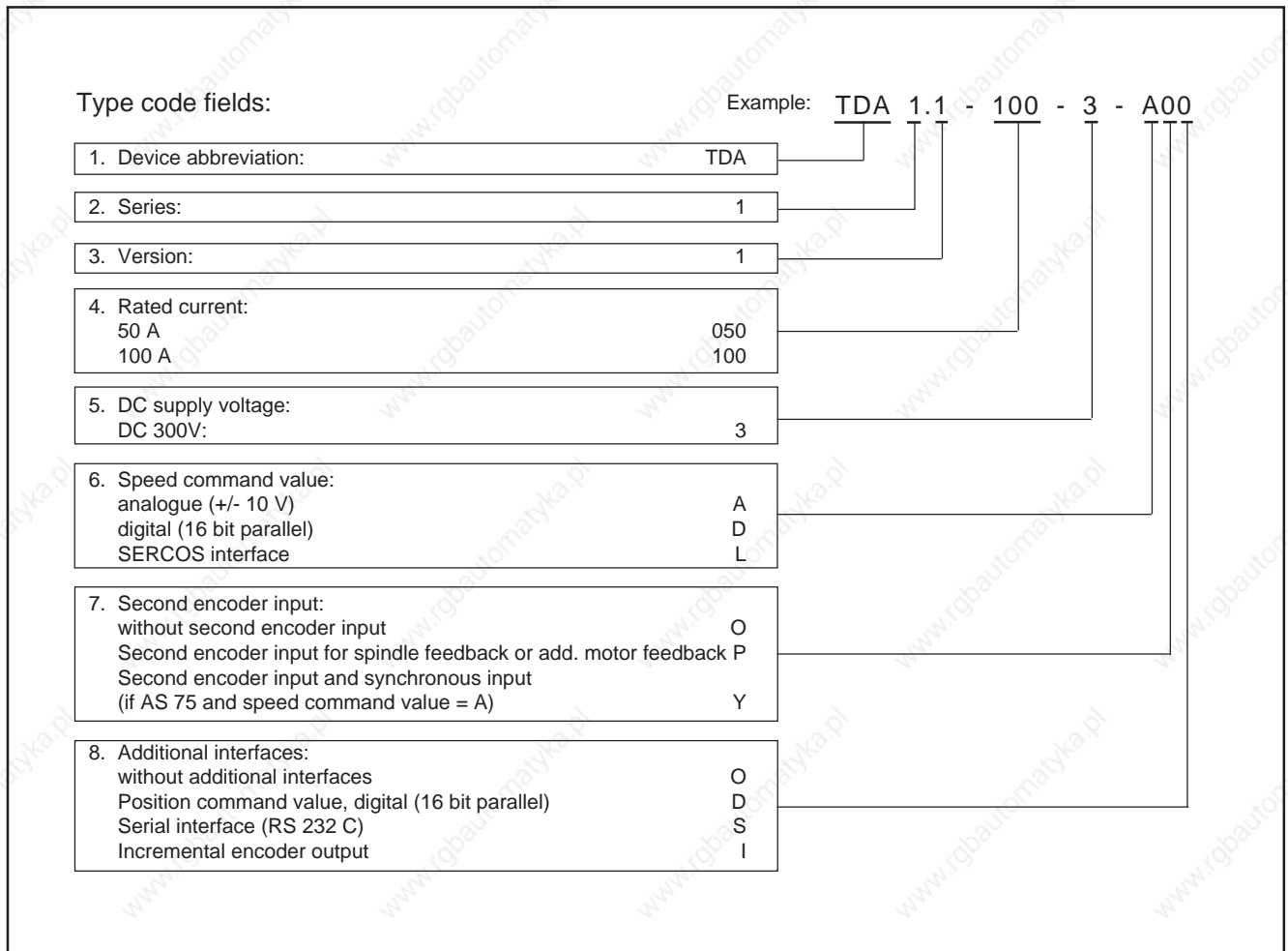
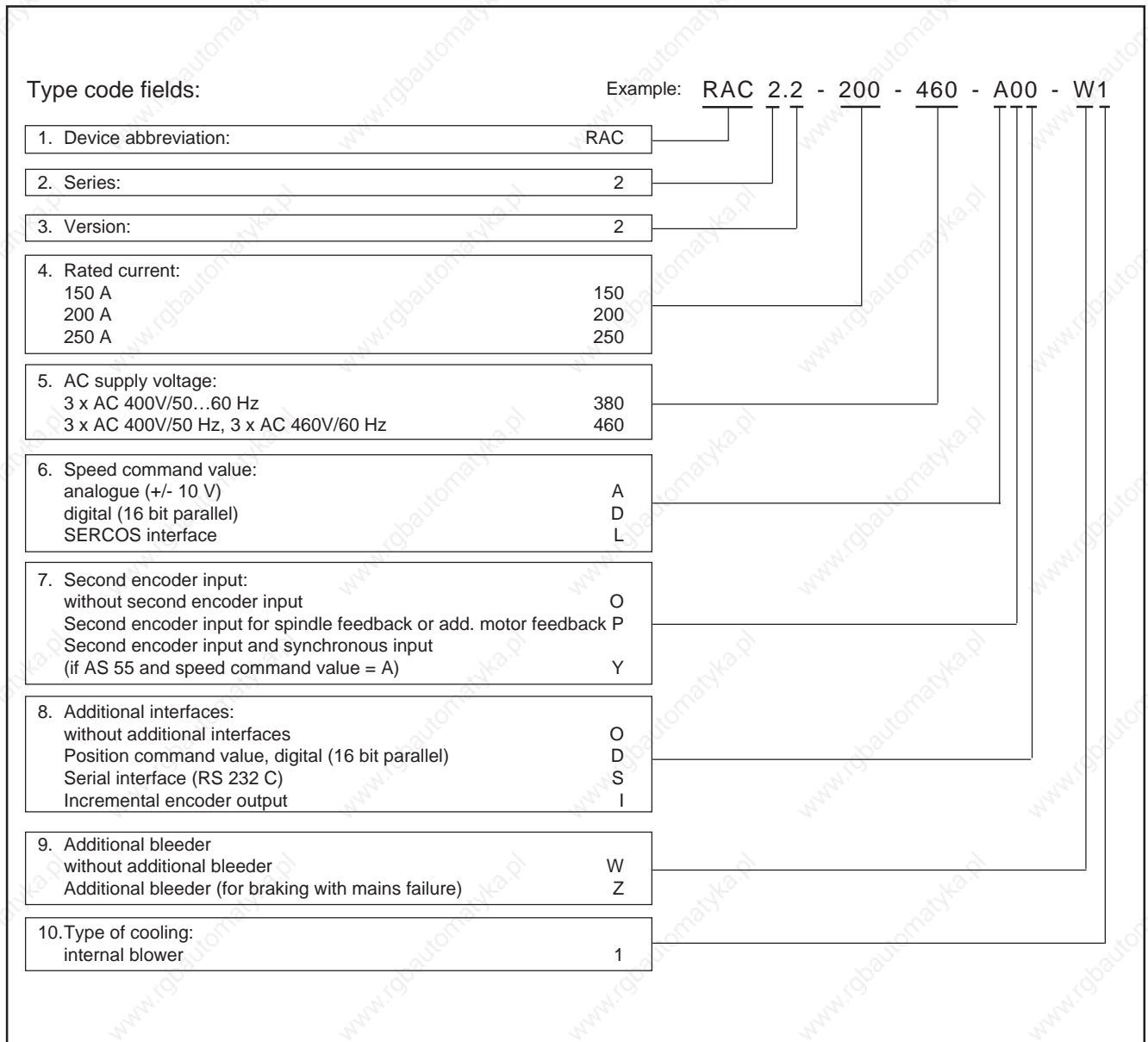

Figure 117: Type codes for TDA 1

## 8. Abbreviations, Agreements, Type Codes



*Figure 118: Type codes for RAC 2*

## 8. Abbreviations, Agreements, Type Codes

Type code fields:	Example:
1. Device abbreviation:	RAC
2. Series:	3
3. Version:	1
4. Rated current: 100 A 150 A	100 150
5. AC supply voltage for power electronics: 3 x 380V...460V; 50...60 Hz	460
6. Speed command value: analogue (+/- 10 V) digital (16 bit parallel) SERCOS interface	A D L
7. Second encoder input: without Second encoder input Second encoder input for spindle feedback or add. motor feedback P Second encoder input and synchronous input (if AS 65 and speed command value = A)	O P Y
8. Additional interfaces: without additional interfaces Position command value, digital (16 bit parallel) Serial interface (RS 232 C) Incremental encoder output	O D S I
9. Additional bleeder: without additional bleeder Additional bleeder (for braking with mains failure)	W Z
10. Type of cooling: internal blower	1
11. AC supply voltage for control electronics: AC 220 V/ 50...60 Hz	220

*Figure 119: Type codes for RAC 3*

## 8. Abbreviations, Agreements, Type Codes

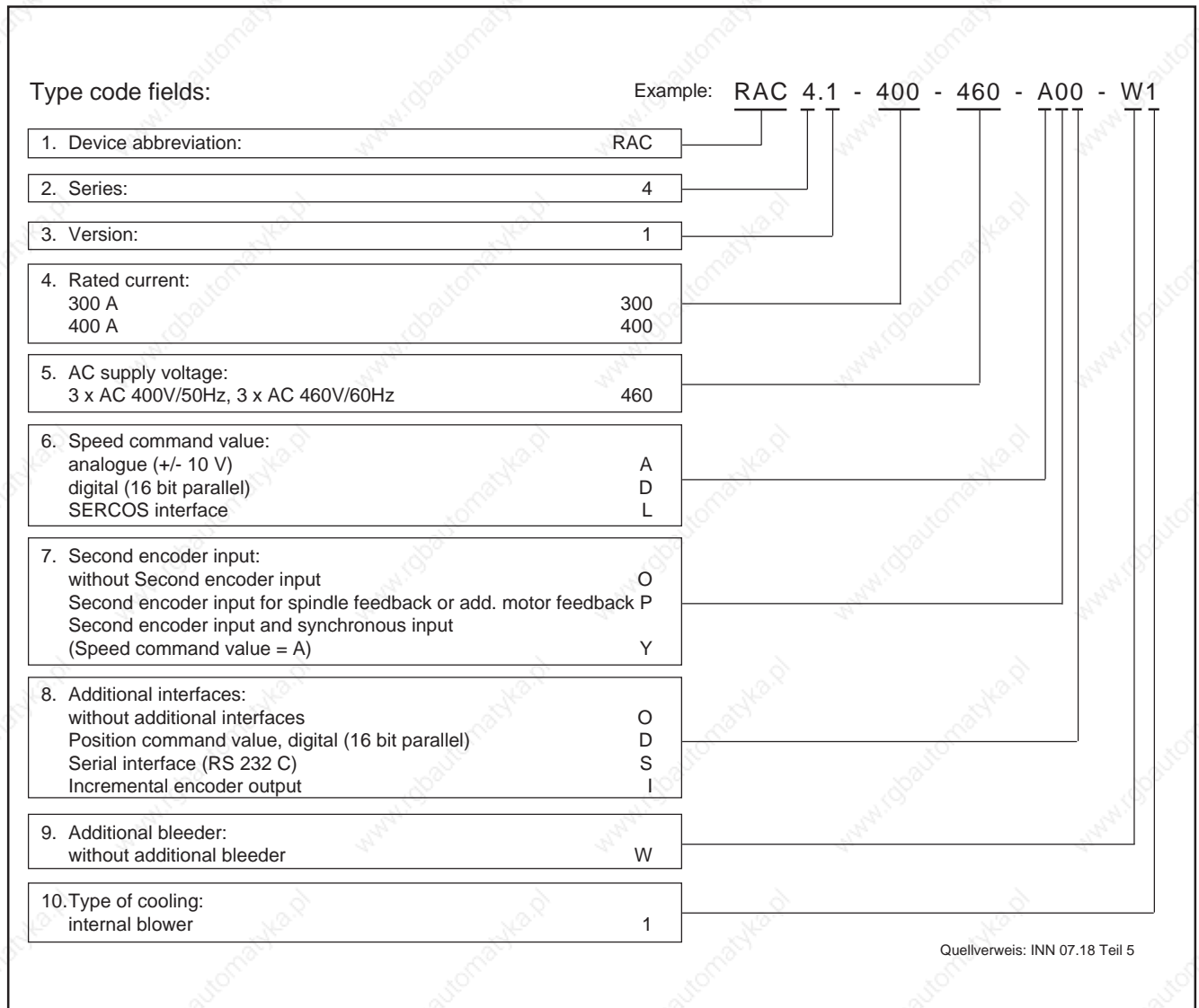

Figure 120: Type codes for RAC 4

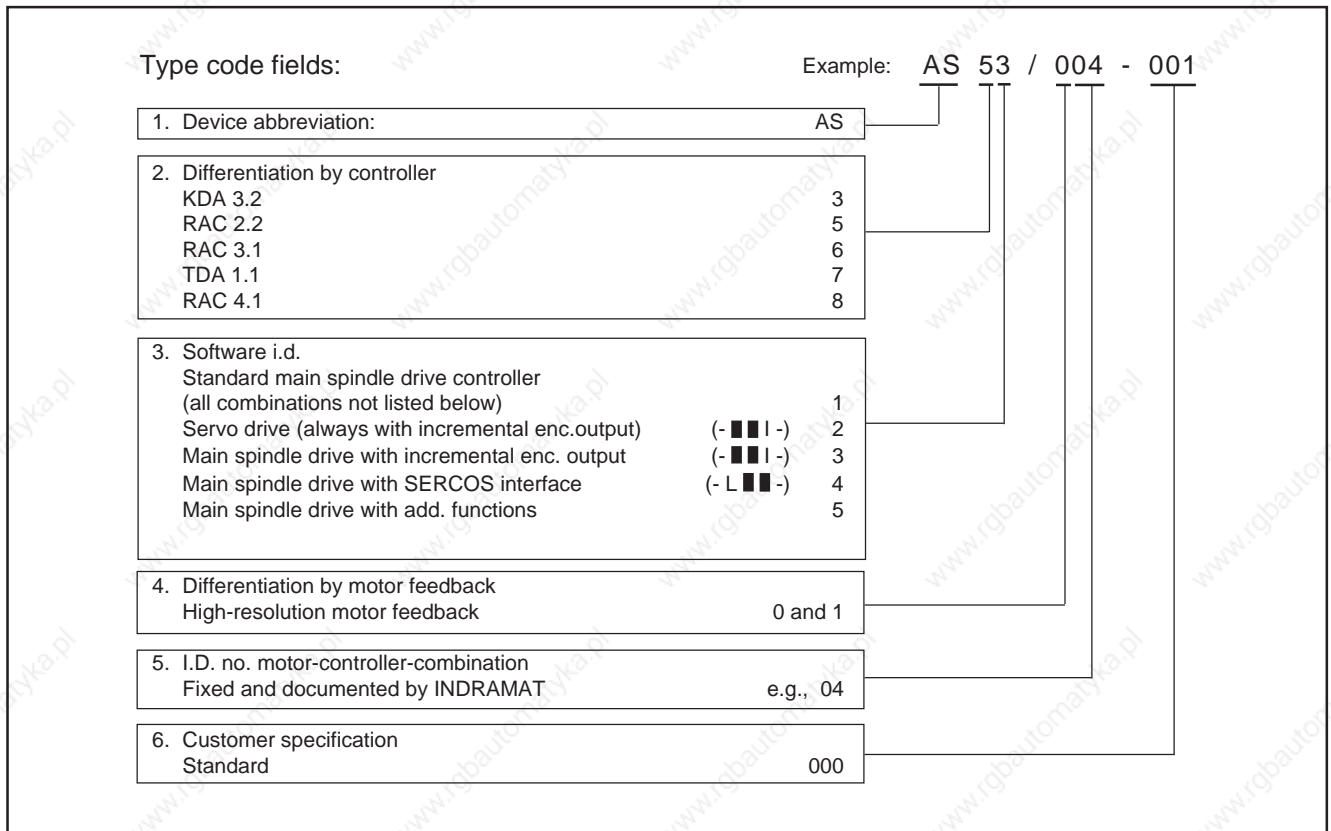

Figure 121: Type codes for AS

## 9. Supplementary documentation

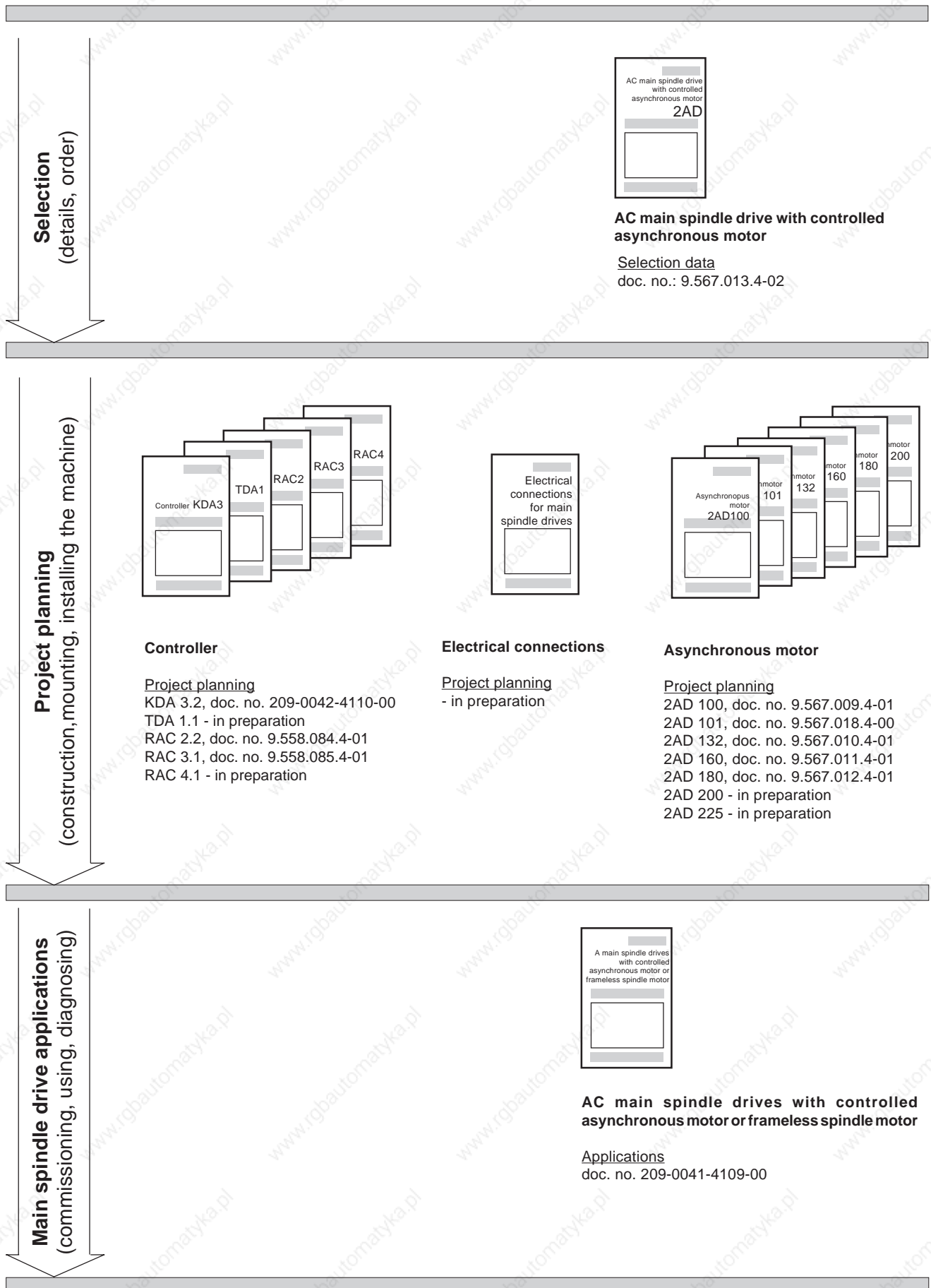
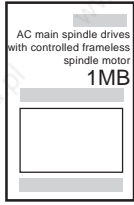
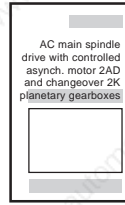

Figure 122: Supplementary documentation



**AC main spindle drive with controlled frameless spindle motor 1MB**

Selection data  
doc. no. 9.567.012.4-00



**AC main spindle drive with 2AD controlled asynchronous motor and 2K changeover planetary gearbox**

Selection data  
doc. no. 9.567.022.4-00

**Selection**  
(details, order)

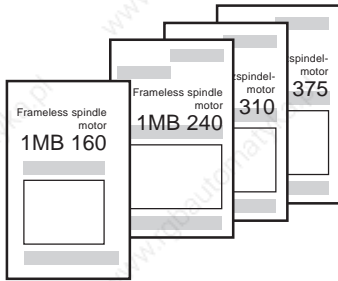

**Frameless spindle motor**

Project planning  
1MB 160, doc. no. 9.576.014.4-00  
1MB 200, doc. no. 9.576.016.4-00  
1MB 240/241, doc. no. 9.576.015.4-00  
1MB 310/312, doc. no. 9.576.008.4-00  
1MB 375, doc. no. 9.576.007.4-00

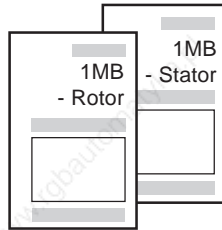

Mounting guidelines  
Stator, doc. no. 9.600.063.4-00  
Rotor, doc. no. 9.600.062.4-02

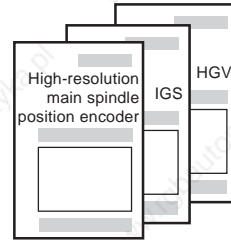

**Supplementary documentation**

- High-resolution main spindle position encoder
  - Applications doc. no. 9.552.247.4-02
  - Mounting guidelines doc. no. 9.600.060.4-01
- Incremental enc. output IGS doc. no. 9.568.015.4-02
- High-resolution encoder junction HGV doc. no. 9.568.010.4-00

**Project planning**  
(construction, mounting, installing the machine)

**Main spindle drive applications**  
(commissioning, using, diagnosing)

