



Controller

KUKA Roboter GmbH

KR C4 NA; KR C4 CK NA

Specification

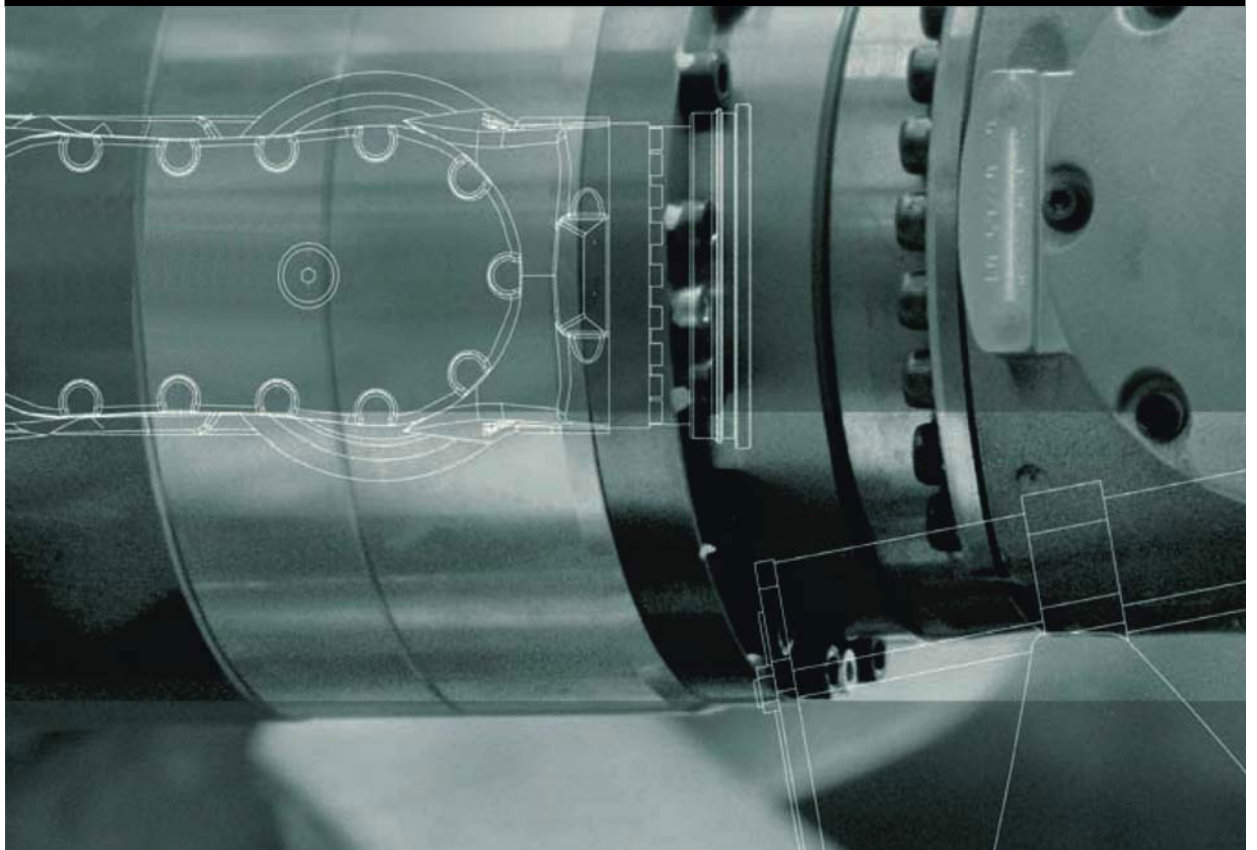

Issued: 17.04.2014

Version: Spez KR C4 NA V6



© Copyright 2014

KUKA Roboter GmbH
Zugspitzstraße 140
D-86165 Augsburg
Germany

This documentation or excerpts therefrom may not be reproduced or disclosed to third parties without the express permission of KUKA Roboter GmbH.

Other functions not described in this documentation may be operable in the controller. The user has no claims to these functions, however, in the case of a replacement or service work.

We have checked the content of this documentation for conformity with the hardware and software described. Nevertheless, discrepancies cannot be precluded, for which reason we are not able to guarantee total conformity. The information in this documentation is checked on a regular basis, however, and necessary corrections will be incorporated in the subsequent edition.

Subject to technical alterations without an effect on the function.

Translation of the original documentation

KIM-PS5-DOC

Publication:	Pub Spez KR C4 NA (PDF) en
Book structure:	Spez KR C4 NA V5.1
Version:	Spez KR C4 NA V6

Contents

1	Product description	7
1.1	Overview of the industrial robot	7
1.2	Overview of the robot controller	7
1.3	KUKA Power Pack	8
1.4	KUKA Servo Pack	9
1.5	Control PC	9
1.6	Cabinet Control Unit	10
1.7	Safety Interface Board	11
1.8	Resolver Digital Converter	11
1.9	Controller System Panel	12
1.10	Low-voltage power supply unit	12
1.11	24 V external power supply	12
1.12	Batteries	13
1.13	Mains filter	13
1.14	Bus devices	13
1.14.1	KCB devices	13
1.14.2	KSB devices and configuration variants	14
1.14.3	KEB devices and configuration variants	14
1.15	Interfaces	16
1.16	Motor connector Xxx, external axes X7.1 and X7.2	17
1.16.1	Connector pin allocation, motor connector X20	19
1.16.2	Connector pin allocation X20.1 and X20.4 (heavy-duty robot)	20
1.16.3	Connector pin allocation X7.1 for external axis 1	21
1.16.4	Connector pin allocation X7.1 and X7.2 for external axes 1 and 2	21
1.16.5	Connector pin allocation X8 (heavy-duty palletizing robot) (4 axes)	22
1.16.6	Connector pin allocation X20 (palletizing robot) (4 axes)	23
1.16.7	Connector pin allocation X20.1 and X20.4 (heavy-duty palletizing robot) (5 axes)	24
1.16.8	Connector pin allocation X20 (palletizing robot) (5 axes)	25
1.16.9	Connector pin allocation X81 (4 axes)	26
1.16.10	Connector pin allocation X82 (8 axes)	27
1.16.11	Connector pin allocation X7.1 for palletizing robot, external axis 1	27
1.16.12	Connector pin allocation X7.1 and X7.2 for palletizing robot, for external axes 1 and 2	28
1.17	Multiple connector X81, single connectors X7.1 to X7.4	28
1.17.1	Connector pin allocation X81 (3 axes)	29
1.17.2	Connector pin allocation X81 (4 axes)	30
1.17.3	Connector pin allocation X81, X7.1 (5 axes)	31
1.17.4	Connector pin allocation X81, X7.1 and X7.2 (6 axes)	32
1.17.5	Connector pin allocation X81, X7.1 to X7.3 (7 axes)	33
1.17.6	Connector pin allocation X81, X7.1 to X7.4 (8 axes)	34
1.18	Single connectors X7.1 to X7.8	36
1.18.1	Connector pin allocation X7.1 to X7.3 (3 axes)	37
1.18.2	Connector pin allocation X7.1 to X7.4 (4 axes)	38
1.18.3	Connector pin allocation X7.1 to X7.5 (5 axes)	39
1.18.4	Connector pin allocation X7.1 to X7.6 (6 axes)	40
1.18.5	Connector pin allocation X7.1 to X7.7 (7 axes)	42
1.18.6	Connector pin allocation X7.1 to X7.8 (8 axes)	44
1.19	Control PC interfaces	45

1.19.1	Motherboard D2608-K interfaces	46
1.19.2	Motherboard D3076-K interfaces	47
1.19.3	Motherboard D3236-K interfaces	48
1.20	KUKA smartPAD holder (optional)	49
1.21	Transient limiter	50
1.22	Cabinet cooling	50
1.23	Description of the space for integration of customer options	51
2	Technical data	53
2.1	External 24 V power supply	55
2.2	Safety Interface Board	55
2.3	Dimensions of robot controller	56
2.4	Minimum clearances, robot controller	57
2.5	Swing range for cabinet door	58
2.6	Dimensions of the smartPAD holder (optional)	58
2.7	Dimensions of boreholes for floor mounting	59
2.8	Plates and labels	59
3	Safety	63
3.1	General	63
3.1.1	Liability	63
3.1.2	Intended use of the industrial robot	63
3.1.3	EC declaration of conformity and declaration of incorporation	64
3.1.4	Terms used	64
3.2	Personnel	66
3.3	Workspace, safety zone and danger zone	67
3.4	Triggers for stop reactions	67
3.5	Safety functions	68
3.5.1	Overview of the safety functions	68
3.5.2	Safety controller	69
3.5.3	Mode selection	69
3.5.4	“Operator safety” signal	69
3.5.5	EMERGENCY STOP device	70
3.5.6	Logging off from the higher-level safety controller	70
3.5.7	External EMERGENCY STOP device	71
3.5.8	Enabling device	71
3.5.9	External enabling device	72
3.5.10	External safe operational stop	72
3.5.11	External safety stop 1 and external safety stop 2	72
3.5.12	Velocity monitoring in T1	72
3.6	Additional protective equipment	72
3.6.1	Jog mode	72
3.6.2	Software limit switches	73
3.6.3	Mechanical end stops	73
3.6.4	Mechanical axis range limitation (optional)	73
3.6.5	Axis range monitoring (optional)	73
3.6.6	Options for moving the manipulator without drive energy	74
3.6.7	Labeling on the industrial robot	74
3.6.8	External safeguards	75

3.7	Overview of operating modes and safety functions	75
3.8	Safety measures	76
3.8.1	General safety measures	76
3.8.2	Transportation	77
3.8.3	Start-up and recommissioning	77
3.8.3.1	Checking machine data and safety configuration	78
3.8.3.2	Start-up mode	79
3.8.4	Manual mode	80
3.8.5	Simulation	81
3.8.6	Automatic mode	81
3.8.7	Maintenance and repair	82
3.8.8	Decommissioning, storage and disposal	83
3.8.9	Safety measures for “single point of control”	83
3.9	Applied norms and regulations	84
4	Planning	87
4.1	Electromagnetic compatibility (EMC)	87
4.2	Installation conditions	87
4.3	Connection conditions	89
4.4	Fastening the KUKA smartPAD holder (optional)	90
4.5	Power supply connection on the main switch	91
4.6	Description of safety interface X11	91
4.6.1	Interface X11	92
4.6.2	Interface X11 – external enabling switch	95
4.6.3	EMERGENCY STOP device on the robot controller (optional)	96
4.6.4	Contact diagram for connector X11	97
4.6.5	Wiring example for safe inputs and outputs	98
4.7	Safety functions via Ethernet safety interface (optional)	100
4.7.1	Schematic circuit diagram for enabling switches	103
4.7.2	SafeOperation via Ethernet safety interface (optional)	104
4.8	EtherCAT connection on the CIB	107
4.9	PE equipotential bonding	107
4.10	Modifying the system configuration, exchanging devices	109
4.11	Operator safety acknowledgement	109
4.12	Performance level	109
4.12.1	PFH values of the safety functions	109
5	Transportation	111
5.1	Transportation using lifting tackle	111
5.2	Transportation by fork lift truck	112
5.3	Transportation by pallet truck	112
5.4	Transportation with the set of rollers	113
6	Start-up and recommissioning	115
6.1	Installing the robot controller	115
6.2	Connecting the connecting cables	115
6.2.1	Data cables, X21	116
6.3	Fastening the KUKA smartPAD holder (optional)	116
6.4	Plugging in the KUKA smartPAD	116

6.5	Connecting the PE equipotential bonding	117
6.6	Connecting the robot controller to the power supply	117
6.7	Reversing the battery discharge protection measures	120
6.8	Configuring and connecting safety interface X11	121
6.9	Modifying the system configuration, exchanging devices	121
6.10	Start-up mode	121
6.11	Switching on the robot controller	122
7	KUKA Service	125
7.1	Requesting support	125
7.2	KUKA Customer Support	125
	Index	133

1 Product description

1.1 Overview of the industrial robot

The industrial robot consists of the following components:

- Manipulator
- Robot controller
- Teach pendant
- Connecting cables
- Software
- Options, accessories

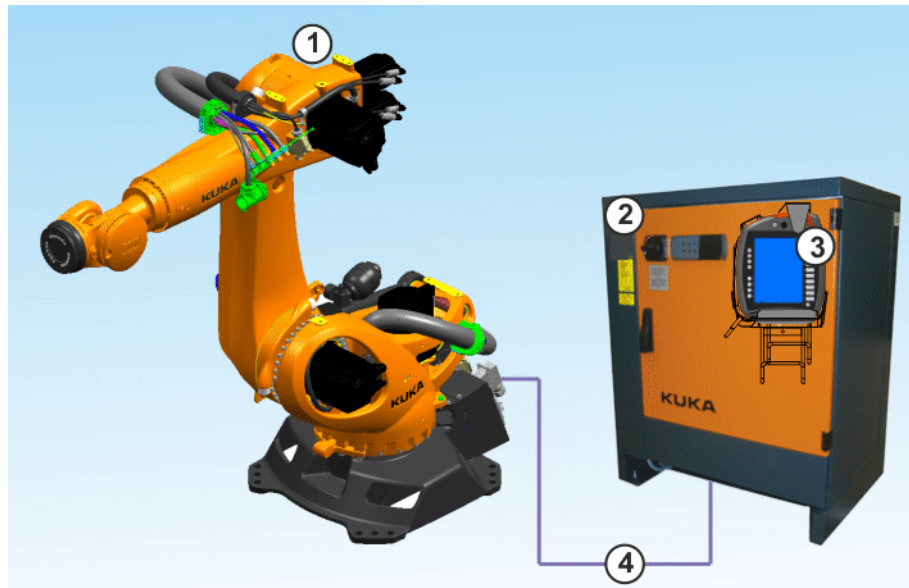

Fig. 1-1: Example of an industrial robot

- | | |
|--------------------|---------------------|
| 1 Manipulator | 3 Teach pendant |
| 2 Robot controller | 4 Connecting cables |

1.2 Overview of the robot controller

The robot controller consists of the following components:

- Control PC (KPC)
- Low-voltage power supply unit
- Drive power supply with drive controller: KUKA Power Pack (KPP)
- Drive controller: KUKA Servo Pack (KSP)
- Teach pendant (KUKA smartPAD)
- Cabinet Control Unit (CCU)
- Controller System Panel (CSP)
- Safety Interface Board (SIB)
- Fuse elements
- Batteries
- Fans
- Connection panel
- Set of rollers (optional)

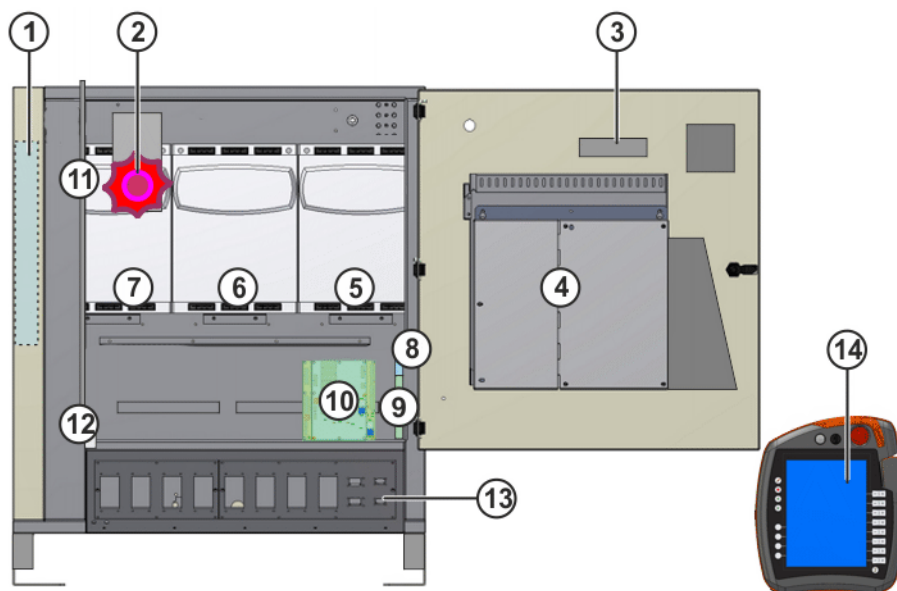

Fig. 1-2: Overview of the robot controller

- | | |
|--|----------------------|
| 1 Mains filter | 8 Brake filter |
| 2 Main switch | 9 CCU |
| 3 CSP | 10 SIB/Extended SIB |
| 4 Control PC | 11 Transient limiter |
| 5 Drive power supply (drive controller for axes 7 and 8, optional) | 12 Batteries |
| 6 Drive controller for axes 4 to 6 | 13 Connection panel |
| 7 Drive controller for axes 1 to 3 | 14 KUKA smartPAD |

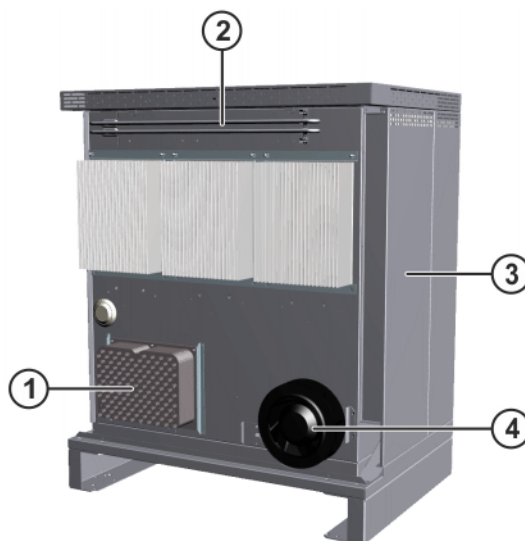

Fig. 1-3: Overview of robot controller, rear view

- | | |
|---------------------------------|------------------|
| 1 Low-voltage power supply unit | 3 Heat exchanger |
| 2 Brake resistor | 4 External fan |

1.3 KUKA Power Pack

Description

The KUKA Power Pack (KPP) is the drive power supply and generates a rectified intermediate circuit voltage from an AC power supply. This intermediate

circuit voltage is used to supply the internal drive controllers and external drives. There are 4 different device variants, all having the same size. There are LEDs on the KPP which indicate the operating state.

- KPP without axis amplifier (KPP 600-20)
- KPP with amplifier for one axis (KPP 600-20-1x40)
Peak output current 1x40 A
- KPP with amplifier for two axes (KPP 600-20-2x40)
Peak output current 2x40 A
- KPP with amplifier for one axis (KPP 600-20-1x64)
Peak output current 64 A

Functions

The KPP has the following functions:

- KPP central AC power supply connection in interconnected operation
- Power output with 400 V supply voltage: 14 kW
- Rated current: 25 A DC
- Connection and disconnection of the supply voltage
- Powering of several axis amplifiers from the DC link
- Integrated brake chopper through connection of an external ballast resistor
- Overload monitoring by the ballast resistor
- Stopping of synchronous servomotors by means of short-circuit braking

1.4 KUKA Servo Pack

Description

The KUKA Servo Pack (KSP) is the drive controller for the manipulator axes. There are 3 different device variants, all having the same size. There are LEDs on the KSP which indicate the operating state.

- KSP for 3 axes (KSP 600-3x40)
Peak output current 3x 40 A
- KSP for 3 axes (KSP 600-3x64)
Peak output current 3x 64 A
- KSP for 3 axes (KSP 600-3x20)
Peak output current 3x 20 A

Functions

The KSP has the following functions:

- Power range: 11 kW to 14 kW per axis amplifier
- Direct infeed of the DC intermediate circuit voltage
- Field-oriented control for servomotors: Torque control

1.5 Control PC

PC components

The control PC (KPC) includes the following components:

- Power supply unit
- Motherboard
- Processor
- Heat sink
- Memory modules
- Hard drive
- LAN Dual NIC network card (not present on all motherboard variants)
- PC fan

- Optional modules, e.g. field bus cards

Functions

The control PC (KPC) is responsible for the following functions of the robot controller:

- User interface
- Program creation, correction, archiving, and maintenance
- Sequence control
- Path planning
- Control of the drive circuit
- Monitoring
- Safety equipment
- Communication with external periphery (other controllers, host computers, PCs, network)

1.6 Cabinet Control Unit

Description

The Cabinet Control Unit (CCU) is the central power distributor and communication interface for all components of the robot controller. The CCU consists of the Cabinet Interface Board (CIB) and the Power Management Board (PMB). All data are transferred via this internal communication interface to the controller for further processing. If the mains voltage fails, the control components continue to be powered by batteries until the position data are saved and the controller has shut down. The charge and quality of the batteries are checked by means of a load test.

Functions

- Communication interface for the components of the robot controller
- Safe inputs and outputs
 - Control of main contactors 1 and 2
 - Mastering test
 - KUKA smartPAD plugged in
- 4 Fast Measurement inputs for customer applications
- Monitoring of the fans in the robot controller
 - External fan
 - Control PC fan
- Temperature sensing:
 - Thermostatic switch for transformer
 - Alarm contact for cooling unit
 - Alarm contact for main switch
 - Temperature sensor for ballast resistor
 - Temperature sensor for internal cabinet temperature
- The following components are connected to the KPC via the KUKA Controller Bus:
 - KPP/KSP
 - Resolver digital converter
- The following operator panels and service devices are connected to the control PC via the KUKA System Bus:
 - KUKA Operator Panel Interface
- Diagnostic LEDs
- Electronic Data Storage Interface

Power supply with battery backup

- KPP
- KSP

- KUKA smartPAD
- Multi-core control PC
- Controller System Panel (CSP)
- Resolver Digital Converter (RDC)
- Standard SIB or Standard and Extended SIB (optional)

Power supply without battery backup

- Motor brakes
- External fan
- Customer interface

1.7 Safety Interface Board

Description The Safety Interface Board (SIB) is an integral part of the safety interface. 2 different SIBs are used in the robot controller, the Standard SIB and the Extended SIB, depending on the configuration of the safety interface. The Standard SIB and the Extended SIB incorporate sensing, control and switching functions. The Extended SIB can only be operated together with the Standard SIB. The output signals are provided as electrically isolated outputs.

The Standard SIB contains the following safe inputs and outputs:

- 5 safe inputs
- 3 safe outputs

The Extended SIB contains the following safe inputs and outputs:

- 8 safe inputs
- 8 safe outputs

Functions The Standard SIB has the following functions:

- Safe inputs and outputs for the discrete safety interface of the robot controller

The Extended SIB has the following functions:

- Safe inputs and outputs for range selection and range monitoring for the SafeRobot option

or optionally

- Provision of signals for axis range monitoring

1.8 Resolver Digital Converter

Description The Resolver Digital Converter (RDC) is used to detect the motor position data. 8 resolvers can be connected to the RDC. In addition, the motor temperatures are measured and evaluated. For non-volatile data storage, the EDS is located in the RDC box.

The RDC is mounted in an RDC box on the base frame of the manipulator.

Functions The RDC has the following functions:

- Safe acquisition of up to 8 motor position data streams via resolver
- Detection of up to 8 motor operating temperatures
- Communication with the robot controller
- Monitoring of the resolver cables
- The following non-volatile data are stored on the EDS:
 - Position data
 - KUKA configuration

1.9 Controller System Panel

Description The Controller System Panel (CSP) is a display element for the operating state and has the following connections:

- USB1
- USB2
- KLI (optional)
- KSI (optional)

Overview

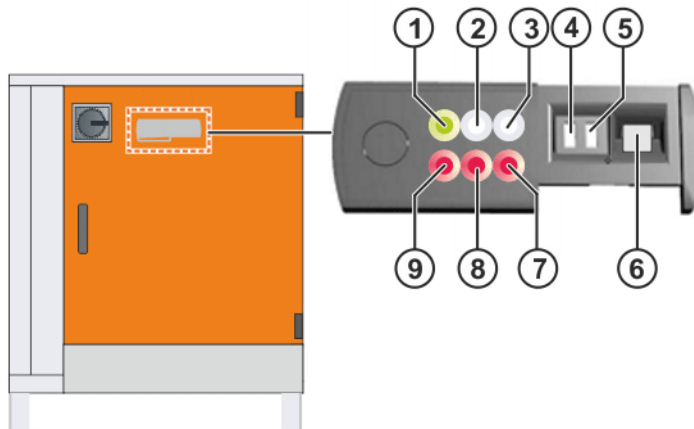

Fig. 1-4: Arrangement of LEDs and connectors on CSP

Item	Component	Color	Meaning
1	LED 1	Green	Operating LED
2	LED 2	White	Sleep LED
3	LED 3	White	Automatic LED
4	USB 1	-	-
5	USB 2	-	-
6	RJ45	-	KLI, KSI
7	LED 6	Red	Error LED 3
8	LED 5	Red	Error LED 2
9	LED 4	Red	Error LED 1

1.10 Low-voltage power supply unit

Description The low-voltage power supply unit provides power to the components of the robot controller.

A green LED indicates the operating state of the low-voltage power supply unit.

1.11 24 V external power supply

External 24 V power supply is possible via the following interfaces:

- RoboTeam X57
- Interface X11
- Connector X55

Power supply to the KLI switch in the robot controller

The external power supply to the SIB and CIB boards cannot be isolated. If the SIB is supplied externally, the CIB is also supplied externally, and vice versa.

1.12 Batteries

Description In the event of a power failure, or if the power is switched off, the batteries enable the robot controller to be shut down in a controlled manner. The batteries are charged via the CCU and the charge is checked and indicated.

1.13 Mains filter

Description The mains filter (interference suppressor filter) suppresses interference voltages on the power cable.

1.14 Bus devices

Overview

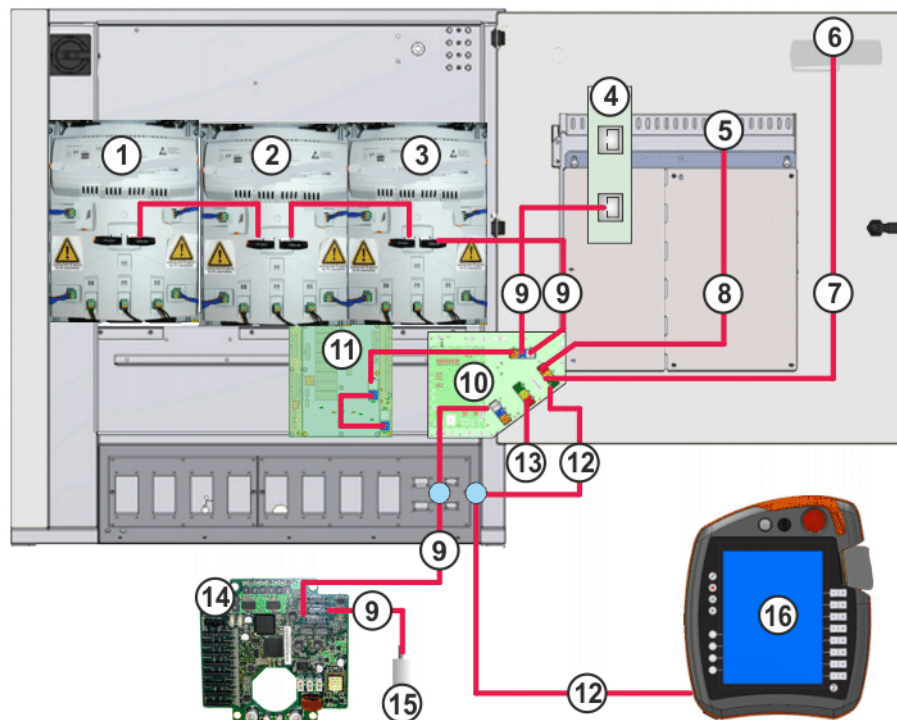

Fig. 1-5: Overview of bus devices

1	KSP, left	9	KUKA Controller Bus (KCB)
2	KSP, middle	10	CCU
3	KPP	11	Standard/Extended SIB (optional)
4	LAN Dual NIC card	12	KOI
5	Ethernet motherboard	13	KUKA Extension Bus (KEB)
6	CSP	14	RDC
7	KSI/KLI	15	Electronic Mastering Device (EMD)
8	KUKA System Bus (KSB)	16	KUKA smartPAD

1.14.1 KCB devices

KCB devices The KCB includes the following devices:

- KPP
- KSP, middle

- KSP, left
- RDC
- CIB
- EMD

1.14.2 KSB devices and configuration variants

KSB devices The KSB includes the following devices:

- CIB SION
- smartPAD SION
- Standard SIB (optional)
- Standard/Extended SIB (optional)

Configuration variants

Application	Config.	CIB	Standard SIB	Extended SIB
Standard Safety without/with SOP via PROFIsafe	Variant 1	X	-	-
Standard Safety via interface	Variant 2	X	X	-
Standard Safety with SOP via interface	Variant 3	X	X	X
Standard Safety without/with SOP via CIP Safety	Variant 4	X	-	-

1.14.3 KEB devices and configuration variants

KEB devices The following components are KEB devices:

- PROFIBUS master
- PROFIBUS slave
- PROFIBUS master/slave
- Expansion of digital I/Os 16/16
- DeviceNet master
- DeviceNet slave
- DeviceNet master/slave
- Digital I/Os 16/16
- Digital I/Os 16/16/4
- Digital I/Os 32/32/4
- Digital/analog I/Os 16/16/2
 - Additional digital I/Os 16/8, welding cabinet (optional)
- Digital/analog I/Os 32/32/4

Configuration variants

Application	Config.	Bus
Connection of PROFIBUS devices	Variant 1	PROFIBUS master
Connection to line PLC with PROFIBUS interface	Variant 2	PROFIBUS slave

Application	Config.	Bus	
Connection of PROFIBUS devices Connection to line PLC with Profibus interface	Variant 3	PROFIBUS master/slave	
Connection of PROFIBUS devices Connection of 16 dig. inputs and 16 dig. outputs with 0.5 A	Variant 4	PROFIBUS master	Expansion of digital I/Os 16/16
Connection to line PLC with PROFIBUS interface Connection of 16 dig. inputs and 16 dig. outputs with 0.5 A	Variant 5	PROFIBUS slave	
Connection of PROFIBUS devices Connection to line PLC with PROFIBUS interface Connection of 16 dig. inputs and 16 dig. outputs with 0.5 A	Variant 6	PROFIBUS master/slave	
Connection of 16 dig. inputs and 16 dig. outputs with 0.5 A	Variant 7	Digital I/Os 16/16	
Connection of 16 dig. inputs and 16 dig. outputs with 0.5/2 A	Variant 8	Digital I/Os 16/16/4	
Connection of 32 dig. inputs and 32 dig. outputs with 0.5/2 A	Variant 9	Digital I/Os 32/32/4	
VKR C2-compatible interface for connection to line PLC	Variant 10	Retrofit	
Connection of EtherCAT devices	Variant 11	-	
Connection of DeviceNet devices	Variant 12	DeviceNet master	
Connection to line PLC with DeviceNet interface	Variant 13	DeviceNet slave	
Connection of DeviceNet devices Connection to line PLC with DeviceNet interface	Variant 14	DeviceNet master/slave	
Connection of DeviceNet devices Connection of 16 dig. inputs and 16 dig. outputs with 0.5 A.	Variant 15	DeviceNet master	Expansion of digital I/Os 16/16
Connection to line PLC with DeviceNet interface Connection of 16 dig. inputs and 16 dig. outputs with 0.5 A.	Variant 16	DeviceNet slave	
Connection of DeviceNet devices Connection to line PLC with DeviceNet interface Connection of 16 dig. inputs and 16 dig. outputs with 0.5 A.	Variant 17	DeviceNet master/slave	
Connection of 16 dig. inputs and 16 dig. outputs with 0.5/2 A and 2 analog inputs	Variant 18	Expansion of digital and analog I/Os 16/16/2	

Application	Config.	Bus
Connection of 16 dig. inputs and 16 dig. outputs with 0.5/2 A and 2 analog inputs and an additional 16 digital inputs and 8 digital outputs	Variant 19	Expansion of digital I/Os 16/16/2 with additional 16 digital inputs and 8 digital outputs
Connection of 32 dig. inputs and 16 dig. outputs with 0.5/4 A and 2 analog inputs	Variant 20	Expansion of digital and analog I/Os 32/32/4

In the following cases a system modification must be carried out by the customer using WorkVisual after connecting customer-specific devices to the corresponding interfaces:

- Connection of PROFIBUS devices
- Connection of EtherCAT devices

1.15 Interfaces

Overview

The connection panel of the robot controller consists of connections for the following cables:

- Power cable / infeed
- Motor cables to the manipulator
- Data cables to the manipulator
- KUKA smartPAD cable
- PE cables
- Peripheral cables

The configuration of the connection panel varies according to the customer-specific version and the options required.

Note

The following safety interfaces can be configured in the robot controller:

- Discrete safety interface X11
- Ethernet safety interface X66
 - PROFIsafe KLI or
 - CIP Safety KLI



The discrete safety interface X11 and the Ethernet safety interface X66 cannot be connected and used together. Only one of the safety interfaces can be used at a time.

The configuration of the connection panel varies according to customer requirements and options. In this documentation, the robot controller is described with the maximum configuration.

Connection panel

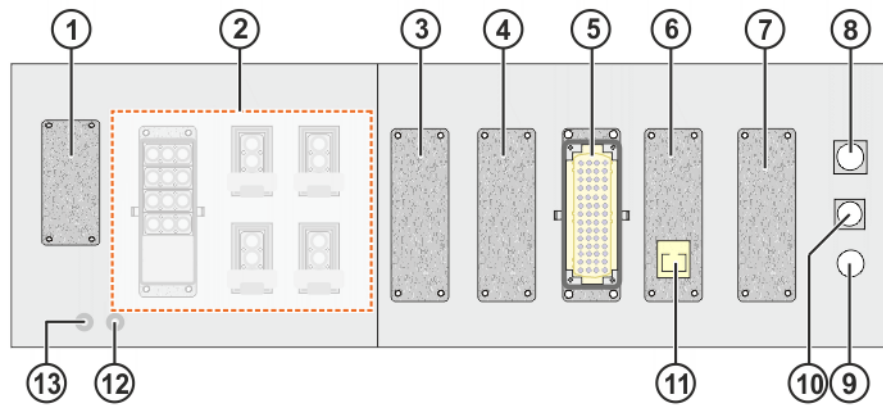

Fig. 1-6: Connection panel overview

- 1 Blanking plate
- 2 Motor connector interfaces
- 3 Optional
- 4 Optional
- 5 Interface X11
- 6 Optional
- 7 Optional
- 8 X19 smartPAD connection
- 9 X42 optional
- 10 X21 RDC connection
- 11 X66 Ethernet safety interface
- 12 PE1 Ground conductor to manipulator
- 13 PE2 Ground conductor to main infeed



Only safety interface X11 or Ethernet safety interface X66 (PRO-FIsafe/CIP Safety) can be configured.



All contactor, relay and valve coils that are connected to the robot controller by the user must be equipped with suitable suppressor diodes. RC elements and VCR resistors are not suitable.

1.16 Motor connector Xxx, external axes X7.1 and X7.2

Connection panel

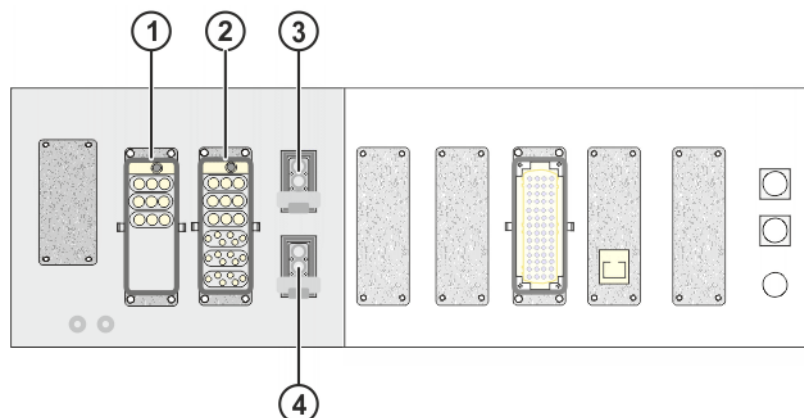

Fig. 1-7: Connection panel

- 1 Slot 1 (>>> "Assignment of slot 1" Page 18)
- 2 Slot 2 (>>> "Assignment of slot 2" Page 18)
- 3 X7.1 Motor connection for external axis 7
- 4 X7.2 Motor connection for external axis 8

Assignment of slot 1

Slot 1 can be assigned the following motor connections:

- X20.1 Motor connector, heavy-duty robot, axes 1-3
- X8 Motor connector, heavy-duty palletizing robot, axes 1-3 and 6
- X81 Motor connector, axes 1 to 4

Assignment of slot 2

Slot 2 can be assigned the following motor connections:

- X20 Motor connector, axes 1 to 6
- X20.4 Motor connector, heavy-duty robot, axes 4 to 6
- X20.4 Motor connector, heavy-duty palletizing robot, axes 5 and 6
- X82 Motor connector, axes 5 to 8

1.16.1 Connector pin allocation, motor connector X20

Connector pin allocation

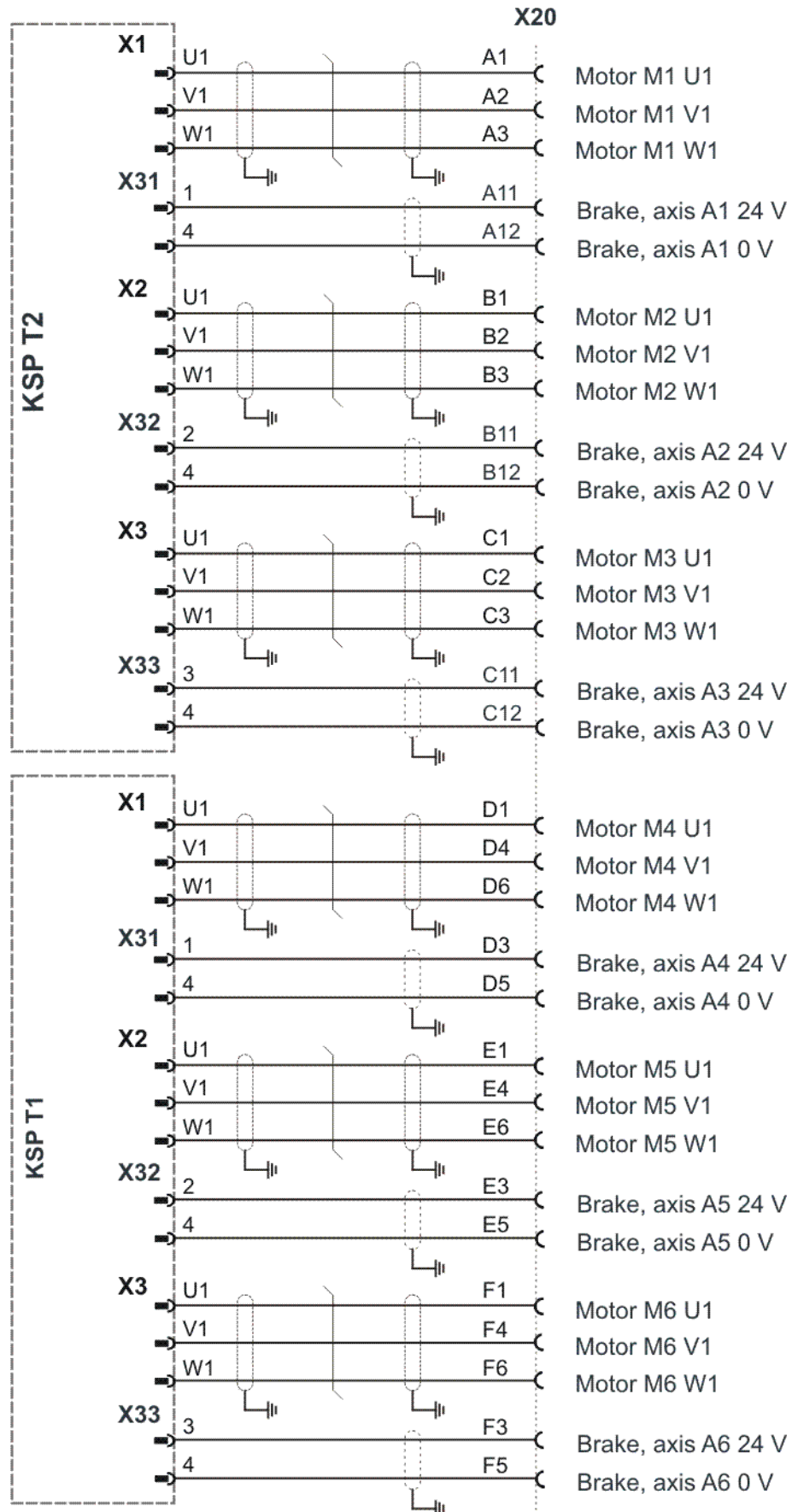

Fig. 1-8: Connector pin allocation for X20

1.16.2 Connector pin allocation X20.1 and X20.4 (heavy-duty robot)

Connector pin allocation

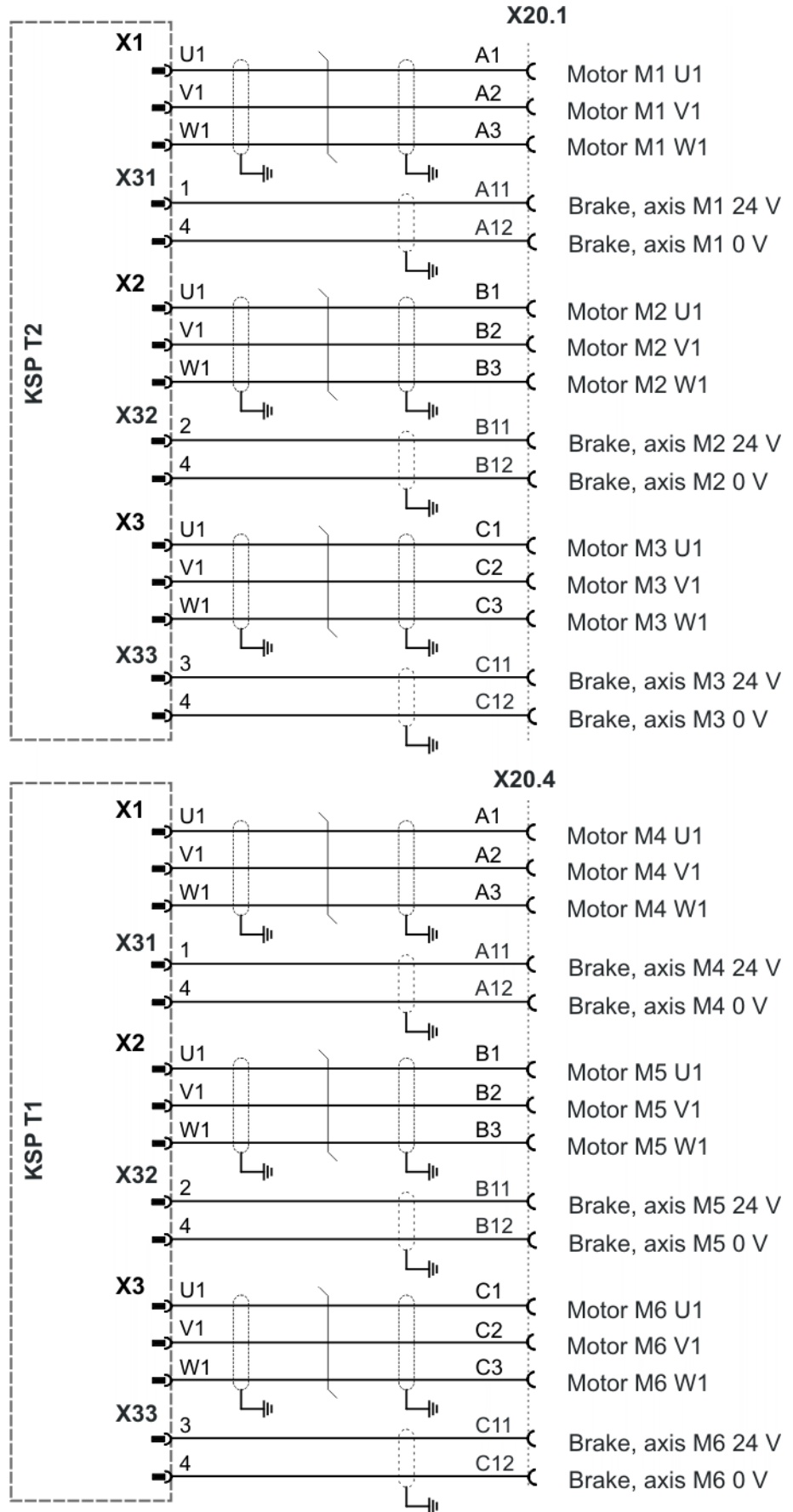

Fig. 1-9: Connector pin allocation X20.1 and X20.4 for heavy-duty robot

1.16.3 Connector pin allocation X7.1 for external axis 1

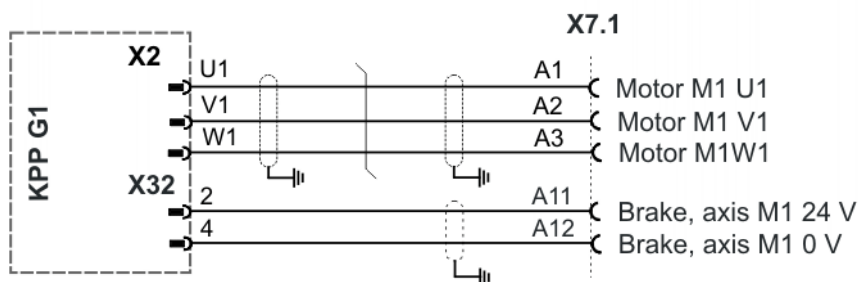

Fig. 1-10: Single connector X7.1

1.16.4 Connector pin allocation X7.1 and X7.2 for external axes 1 and 2

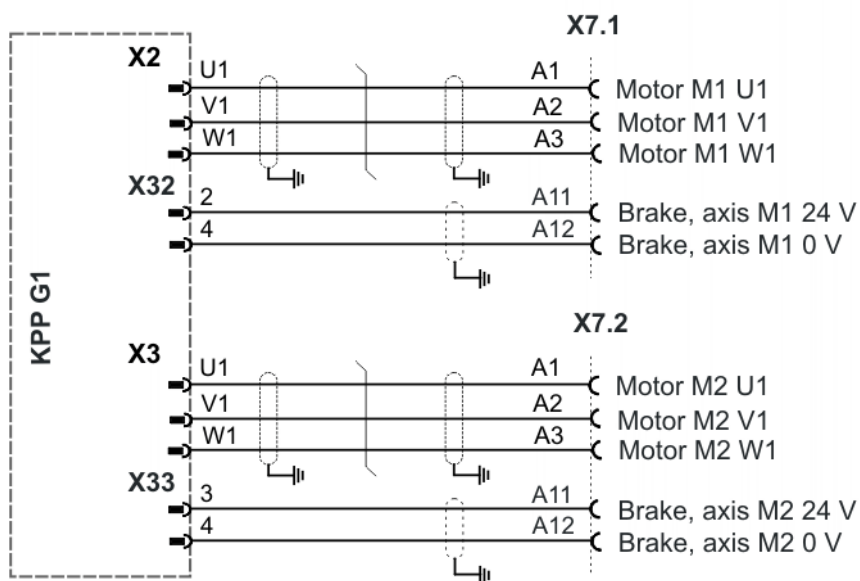

Fig. 1-11: Single connectors X7.1 and X7.2

1.16.5 Connector pin allocation X8 (heavy-duty palletizing robot) (4 axes)

Connector pin allocation

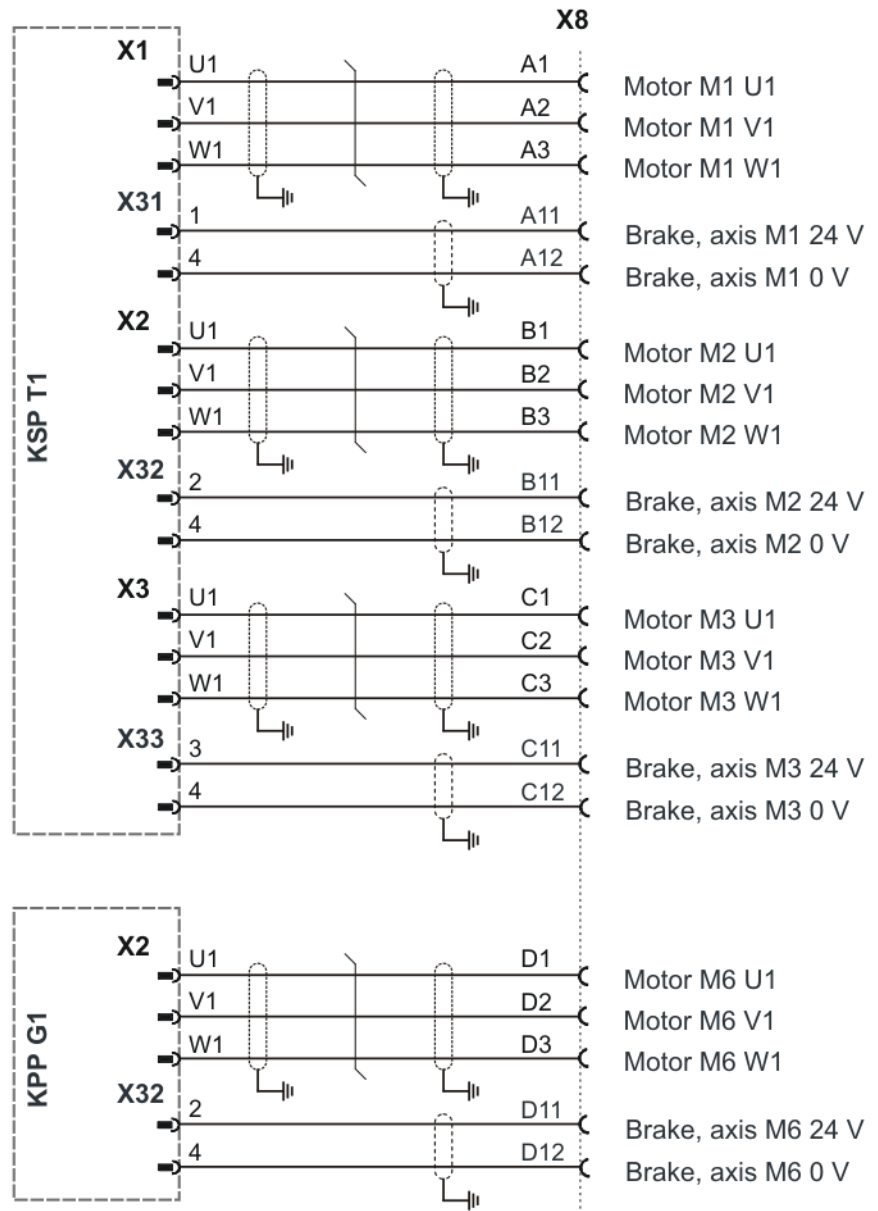

Fig. 1-12: 4-axis heavy-duty palletizing robot, connector pin allocation X8

1.16.6 Connector pin allocation X20 (palletizing robot) (4 axes)

Connector pin allocation

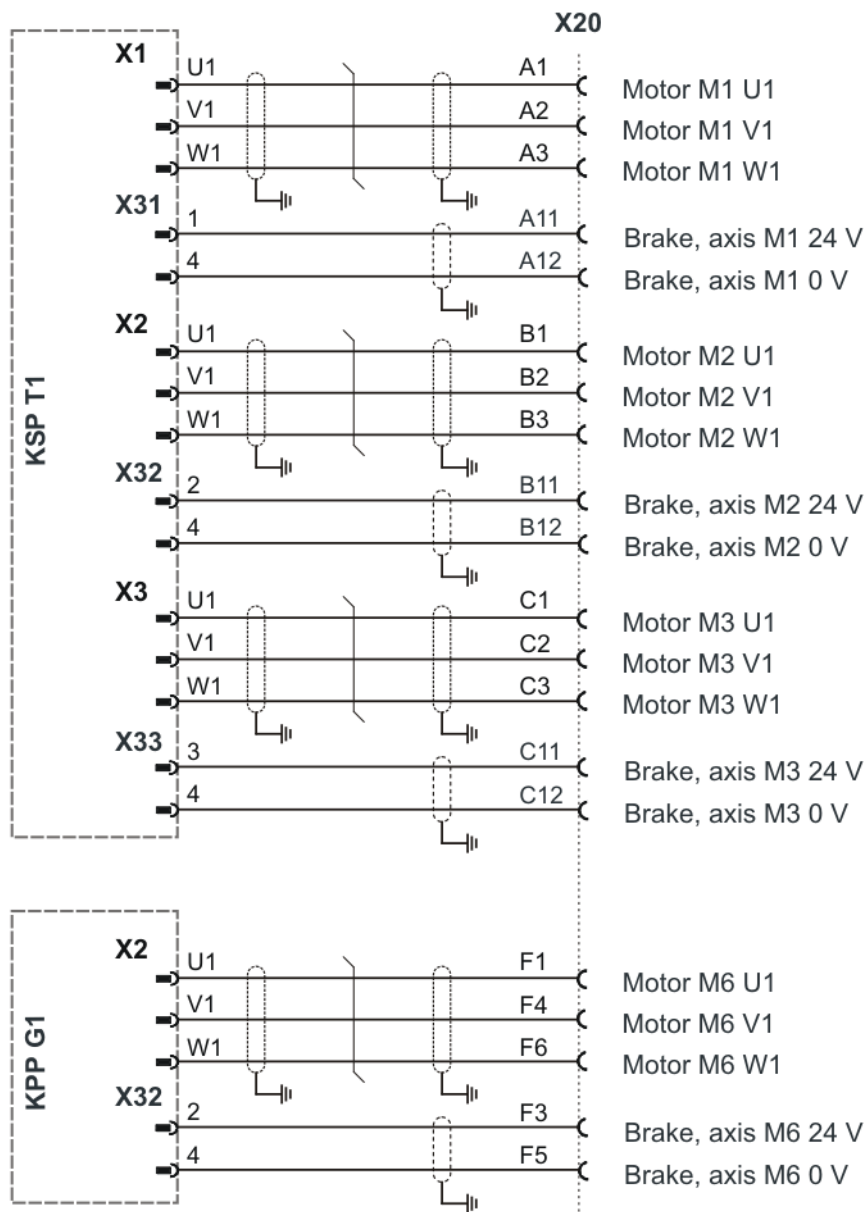

Fig. 1-13: 4-axis palletizing robot, connector pin allocation X20

1.16.7 Connector pin allocation X20.1 and X20.4 (heavy-duty palletizing robot) (5 axes)

Connector pin allocation

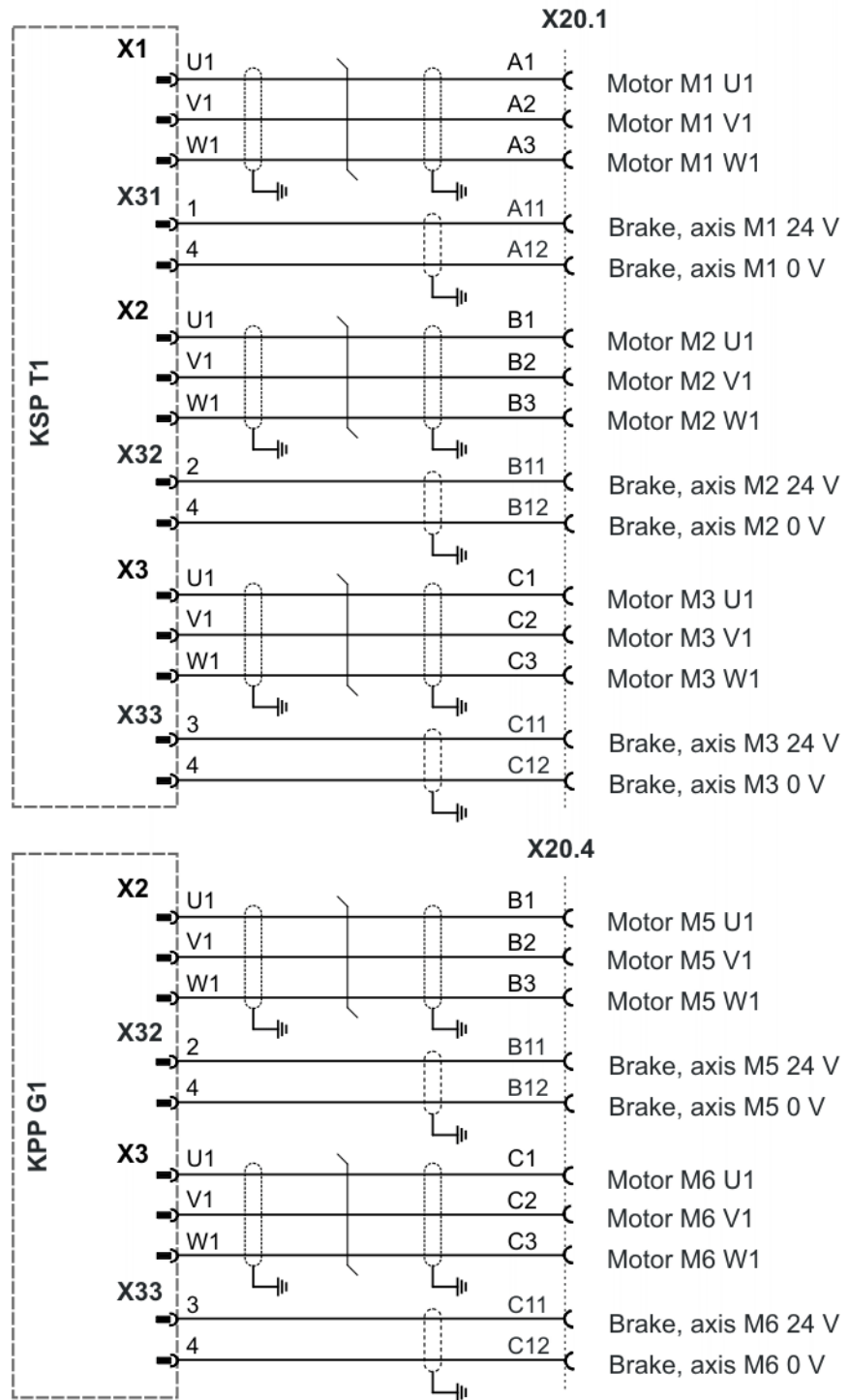

Fig. 1-14: 5-axis heavy-duty palletizing robot, connector pin allocation X20.1 and X20.4

1.16.8 Connector pin allocation X20 (palletizing robot) (5 axes)

Connector pin allocation

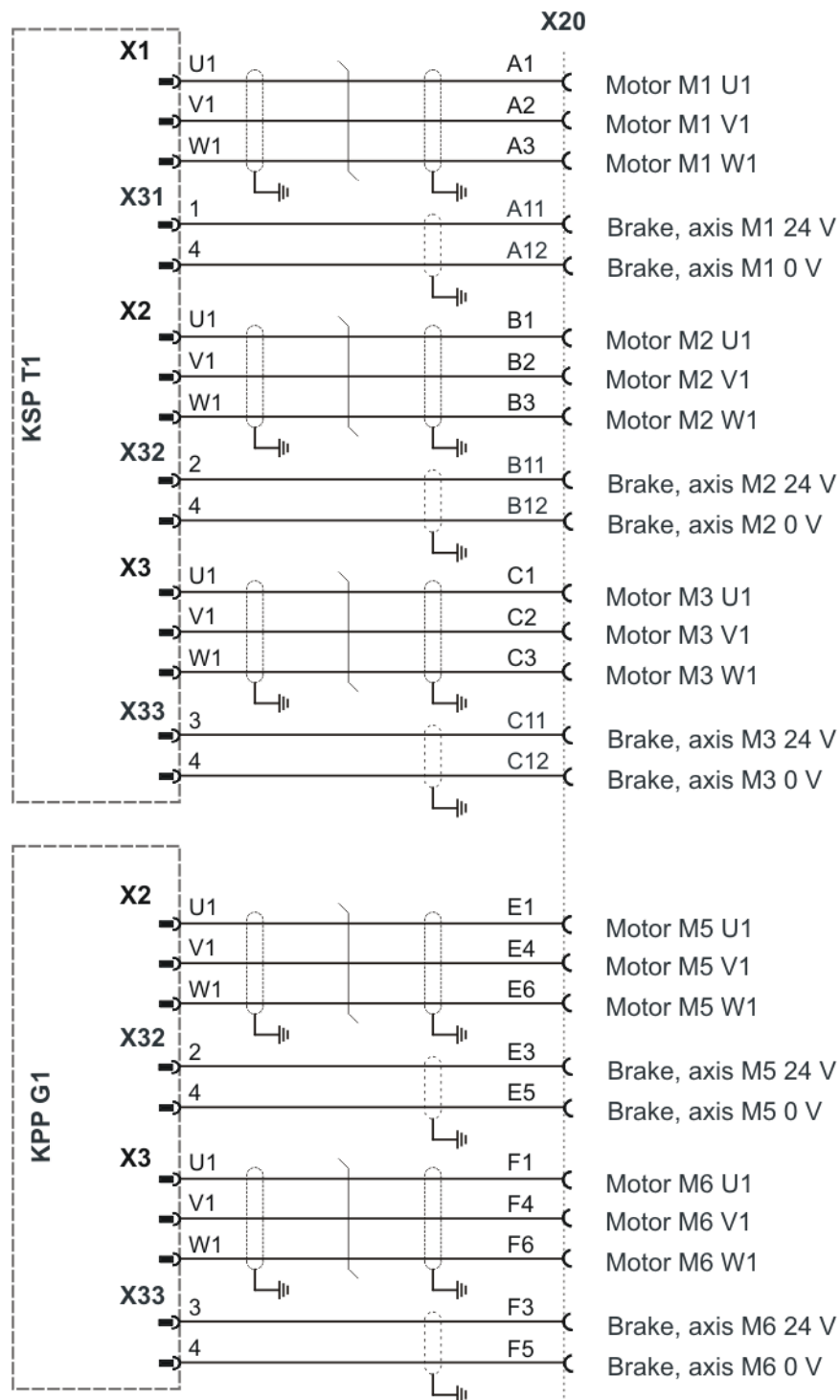

Fig. 1-15: 5-axis palletizing robot, connector pin allocation X20

1.16.9 Connector pin allocation X81 (4 axes)

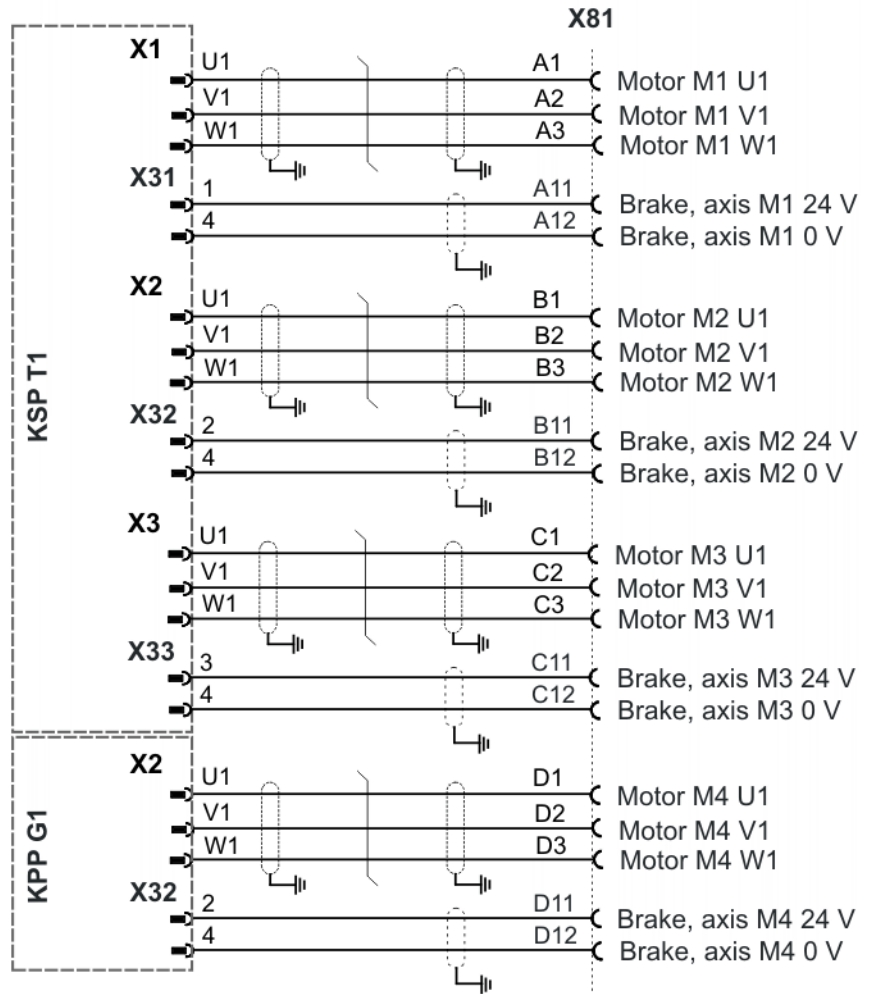

Fig. 1-16: Multiple connector X81

1.16.10 Connector pin allocation X82 (8 axes)

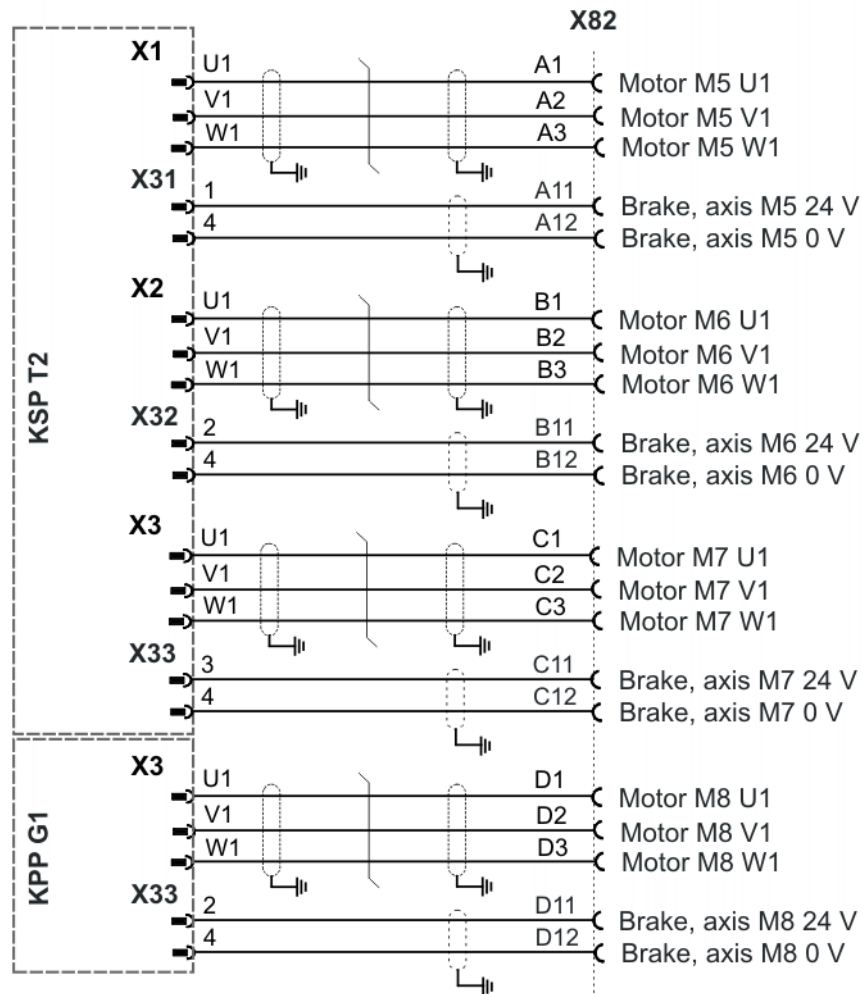

Fig. 1-17: Multiple connector X82

1.16.11 Connector pin allocation X7.1 for palletizing robot, external axis 1

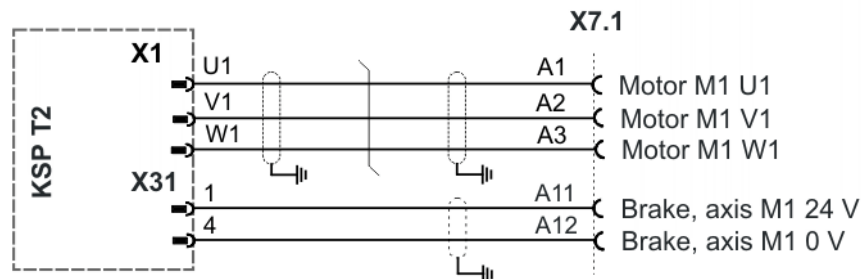

Fig. 1-18: Single connector X7.1

1.16.12 Connector pin allocation X7.1 and X7.2 for palletizing robot, for external axes 1 and 2

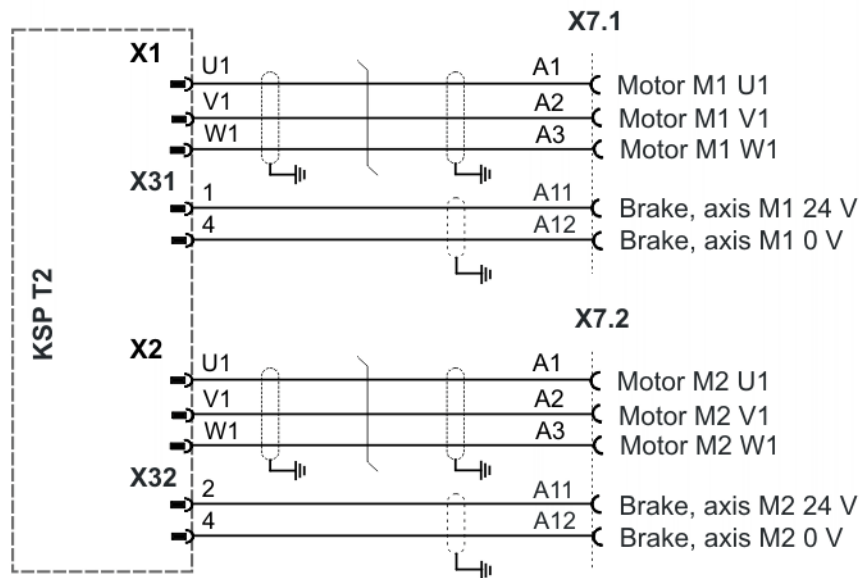

Fig. 1-19: Single connectors X7.1 and X7.2

1.17 Multiple connector X81, single connectors X7.1 to X7.4

Connection panel

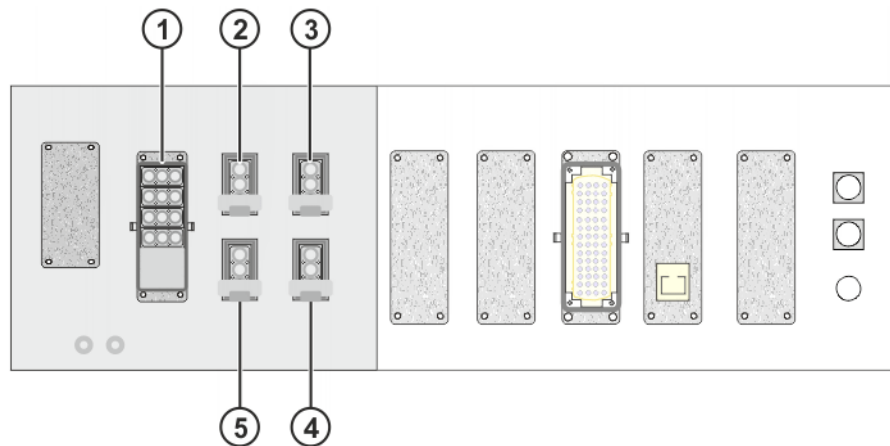

Fig. 1-20: Connection panel with X81 and X7.1 to X7.4

- 1 Multiple connector X81 for axes 1 to 4
- 2 Single connector X7.1 for axis 5
- 3 Single connector X7.3 for axis 7
- 4 Single connector X7.4 for axis 8
- 5 Single connector X7.2 for axis 6

1.17.1 Connector pin allocation X81 (3 axes)

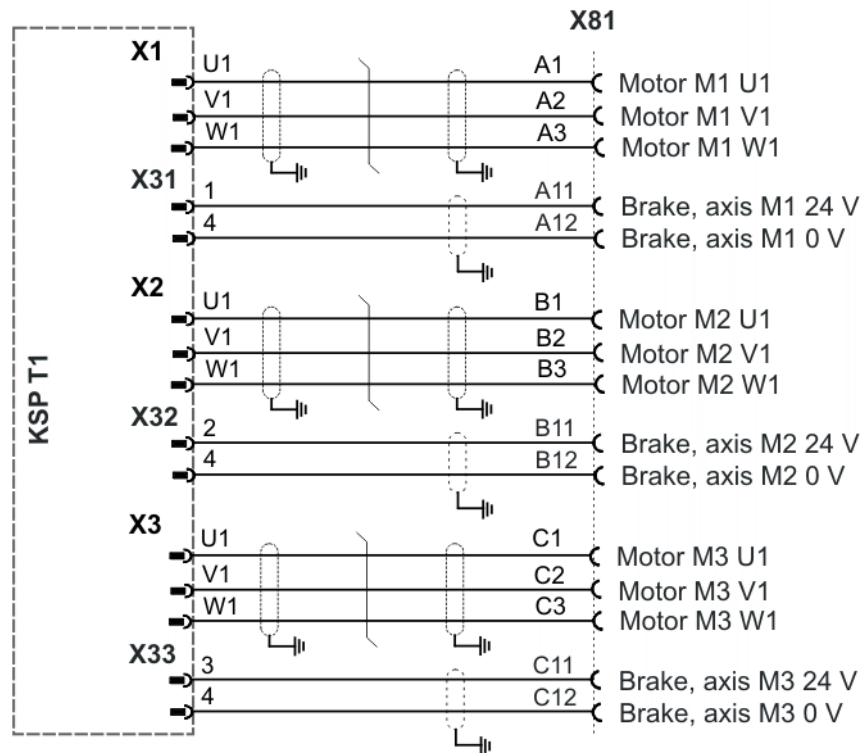

Fig. 1-21: Multiple connector X81

1.17.2 Connector pin allocation X81 (4 axes)

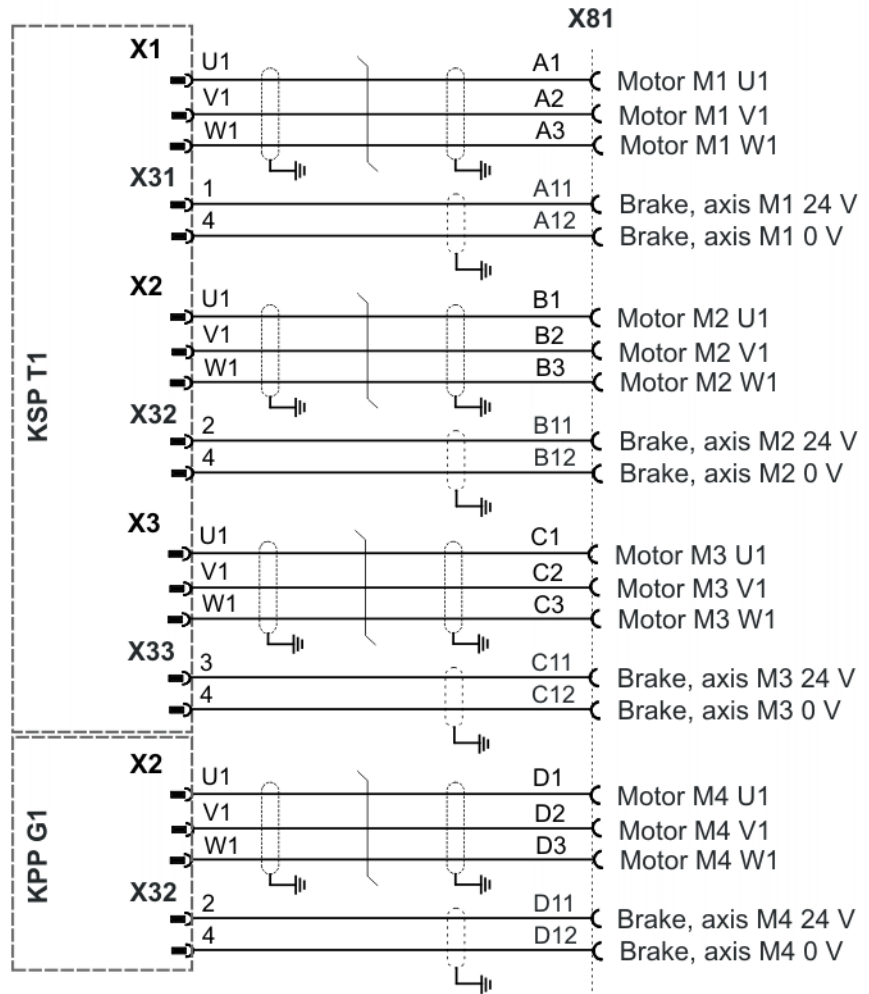

Fig. 1-22: Multiple connector X81

1.17.3 Connector pin allocation X81, X7.1 (5 axes)

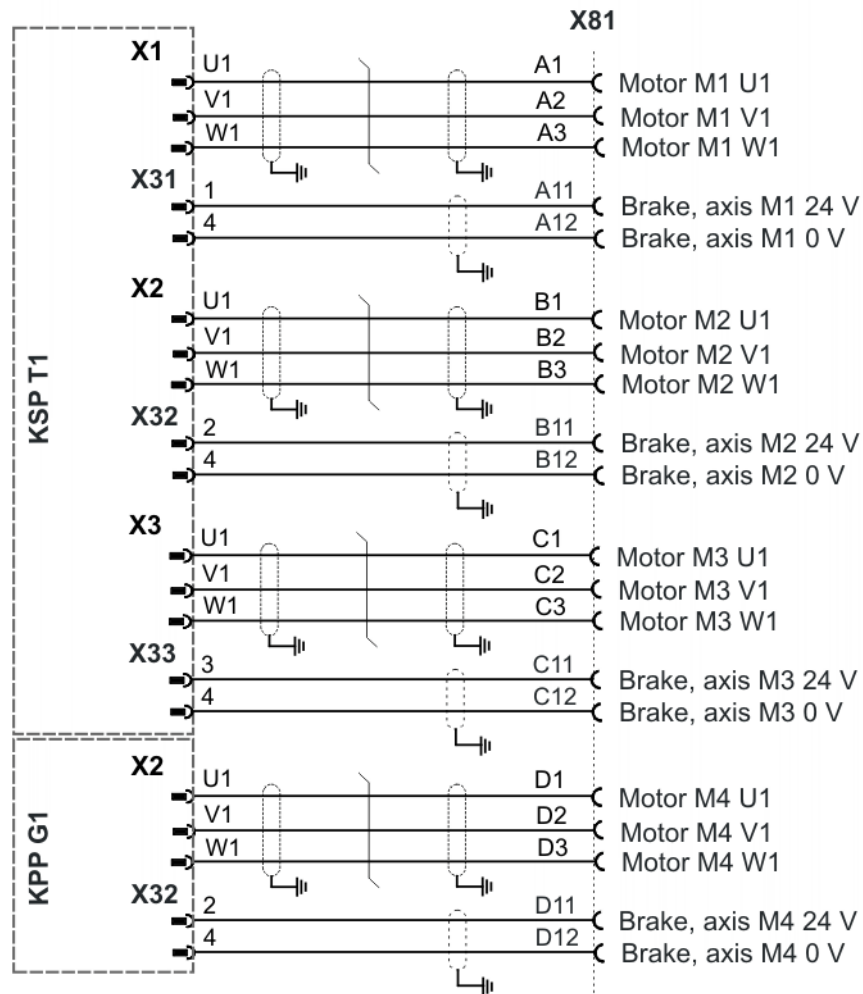

Fig. 1-23: Multiple connector X81

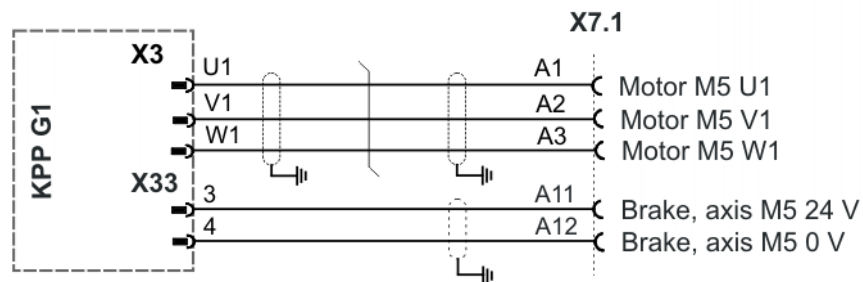

Fig. 1-24: Single connector X7.1

1.17.4 Connector pin allocation X81, X7.1 and X7.2 (6 axes)

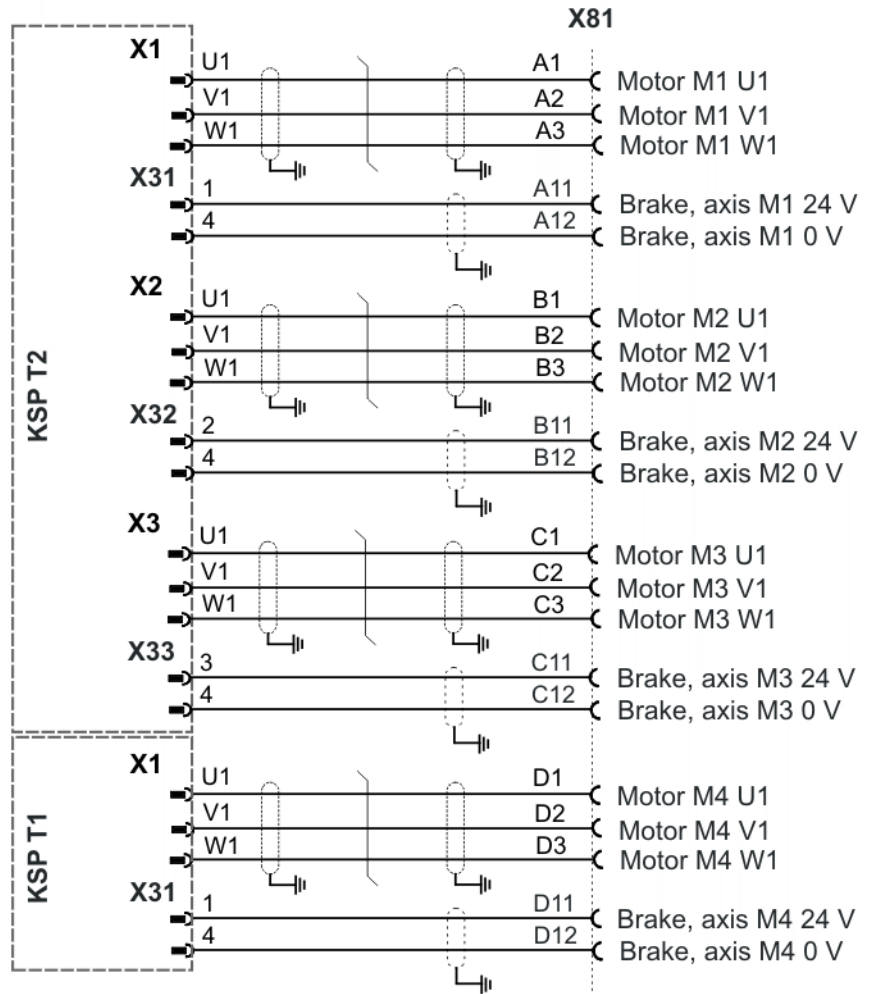

Fig. 1-25: Multiple connector X81

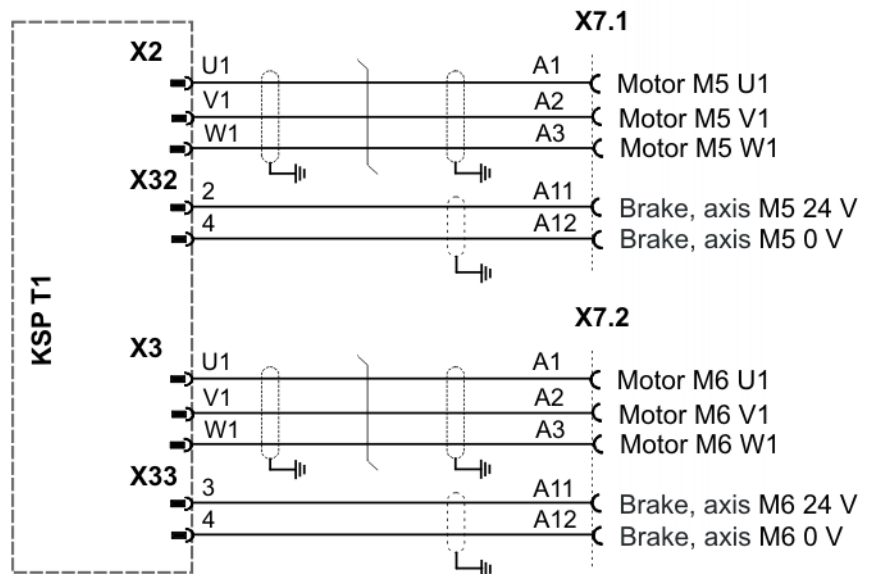

Fig. 1-26: Single connectors X7.1 and X7.2

1.17.5 Connector pin allocation X81, X7.1 to X7.3 (7 axes)

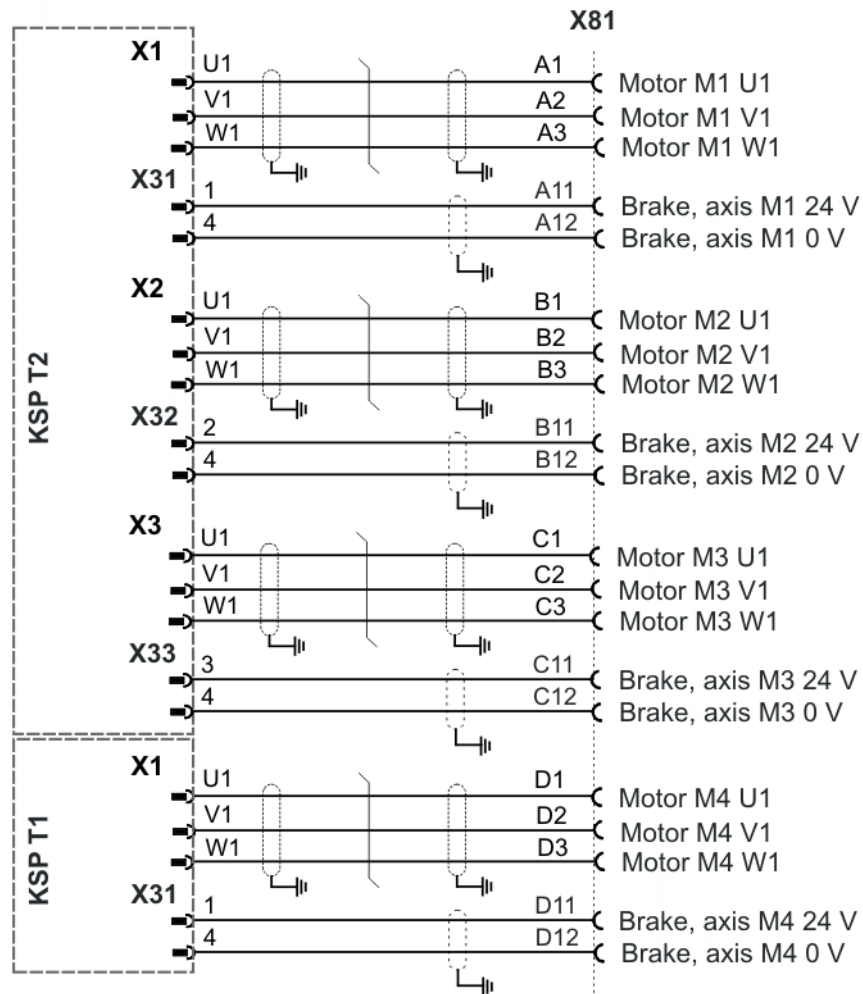

Fig. 1-27: Multiple connector X81

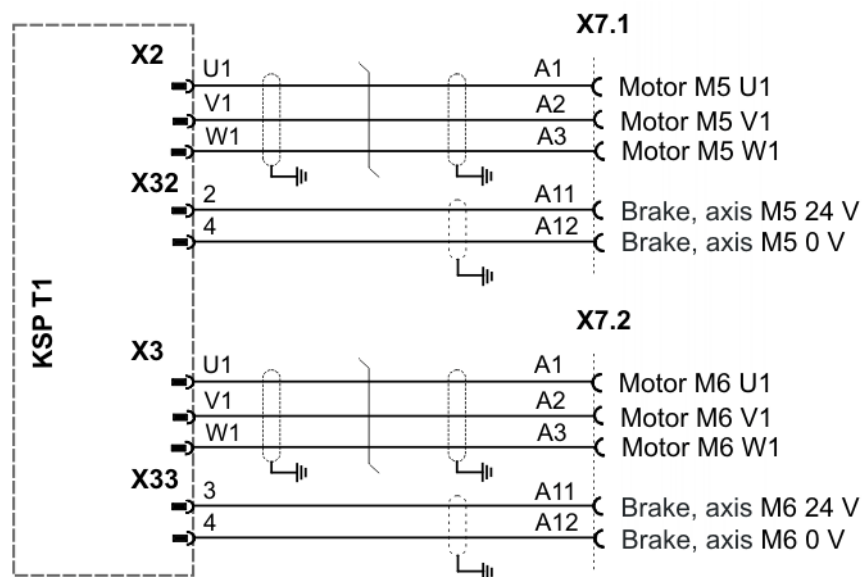

Fig. 1-28: Single connectors X7.1 and X7.2

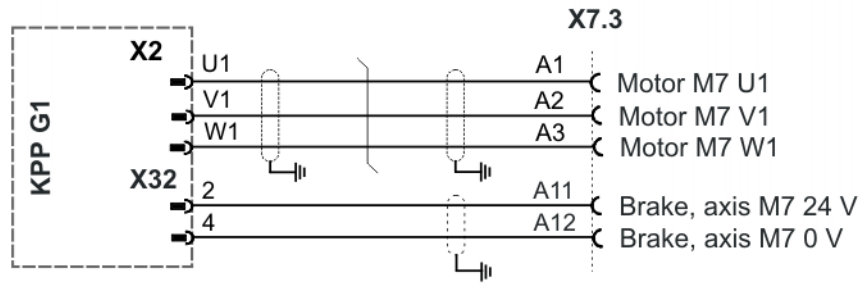

Fig. 1-29: Single connector X7.3

1.17.6 Connector pin allocation X81, X7.1 to X7.4 (8 axes)

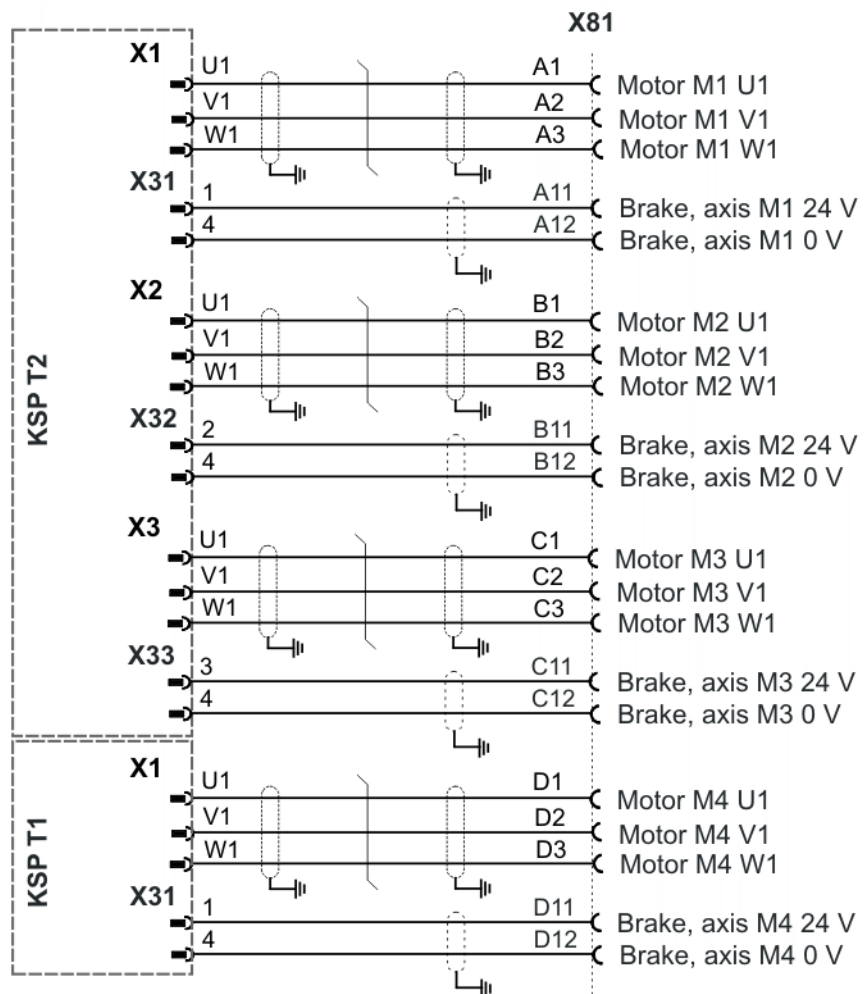

Fig. 1-30: Multiple connector X81

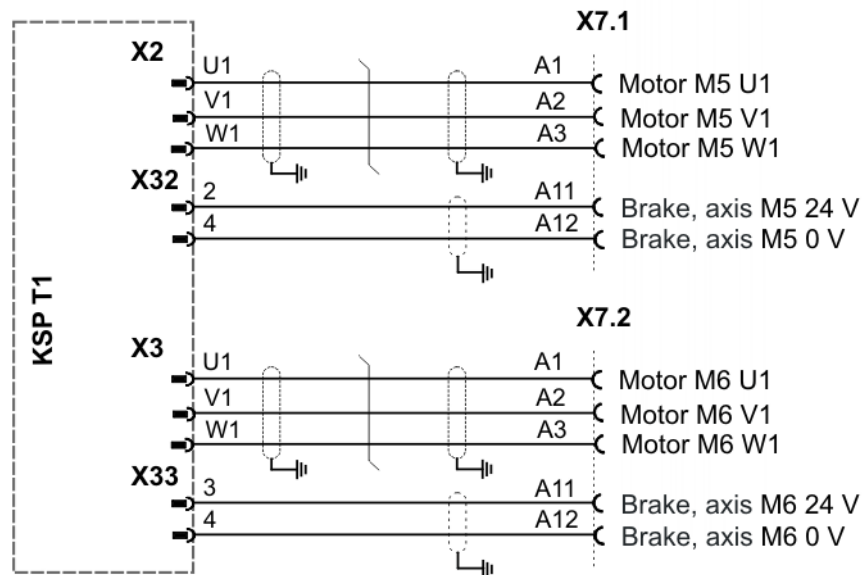

Fig. 1-31: Single connectors X7.1 and X7.2

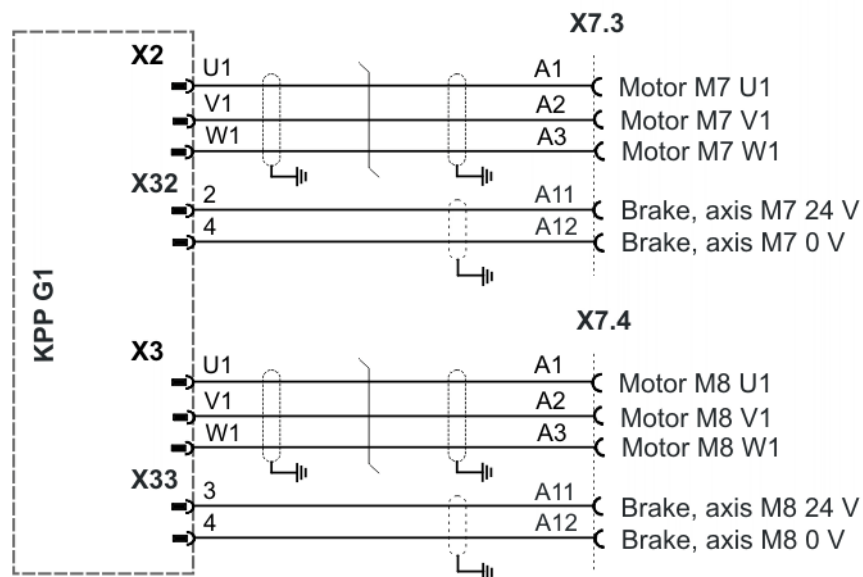

Fig. 1-32: Single connectors X7.3 and X7.4

1.18 Single connectors X7.1 to X7.8

Connector pin allocation

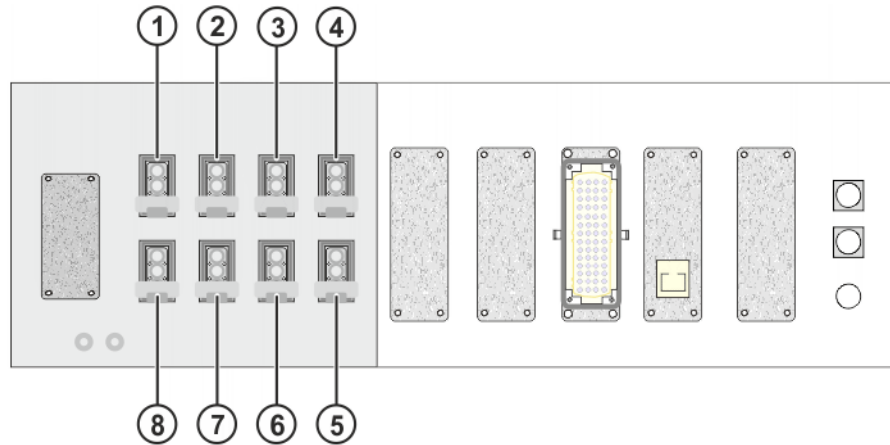

Fig. 1-33: Connection panel with X7.1 to X7.8

- 1 Single connector X7.1 for axis 1
- 2 Single connector X7.3 for axis 3
- 3 Single connector X7.5 for axis 5
- 4 Single connector X7.7 for axis 7
- 5 Single connector X7.8 for axis 8
- 6 Single connector X7.6 for axis 6
- 7 Single connector X7.4 for axis 4
- 8 Single connector X7.2 for axis 2

1.18.1 Connector pin allocation X7.1 to X7.3 (3 axes)

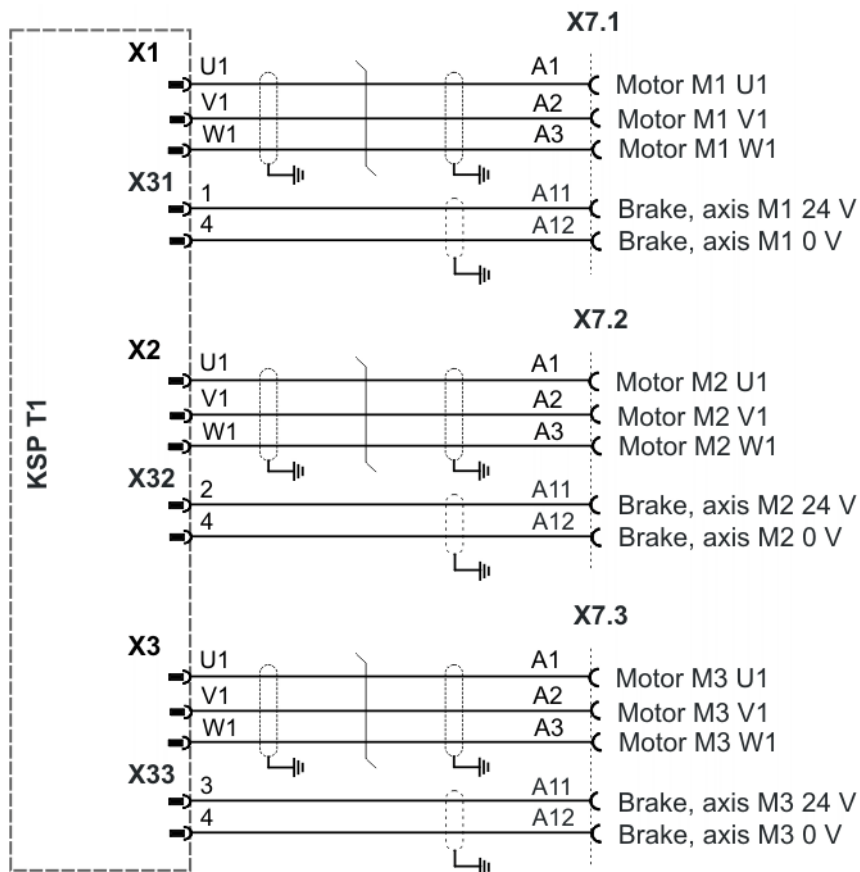

Fig. 1-34: Single connectors X7.1 to X7.3

1.18.2 Connector pin allocation X7.1 to X7.4 (4 axes)

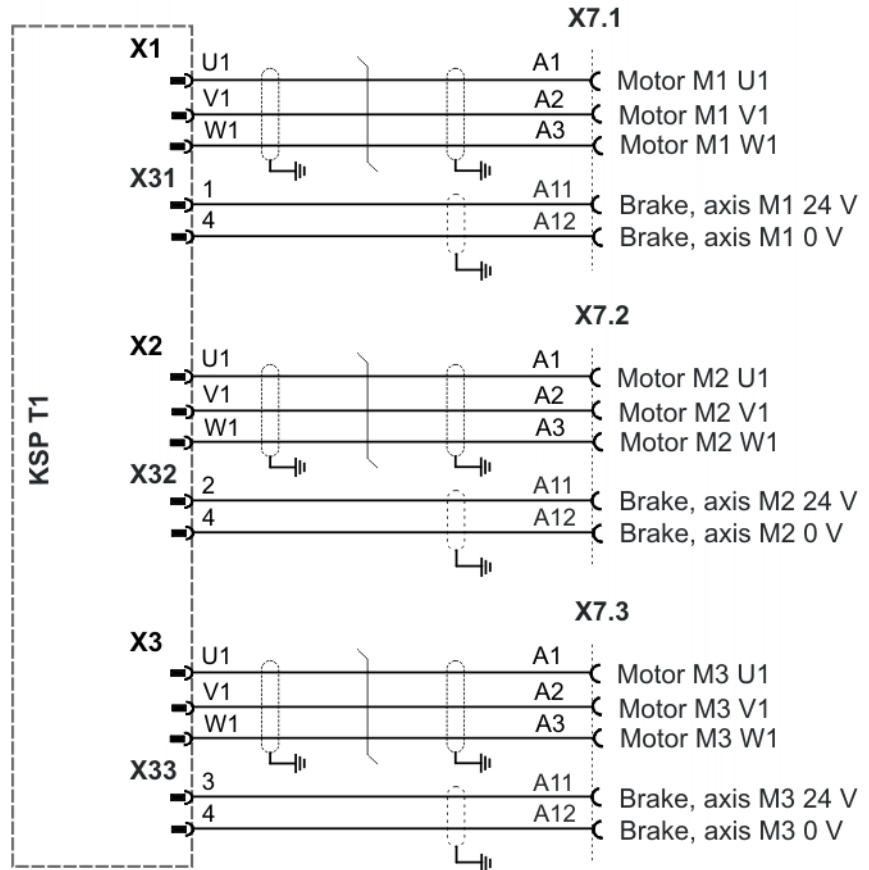

Fig. 1-35: Single connectors X7.1 to X7.3

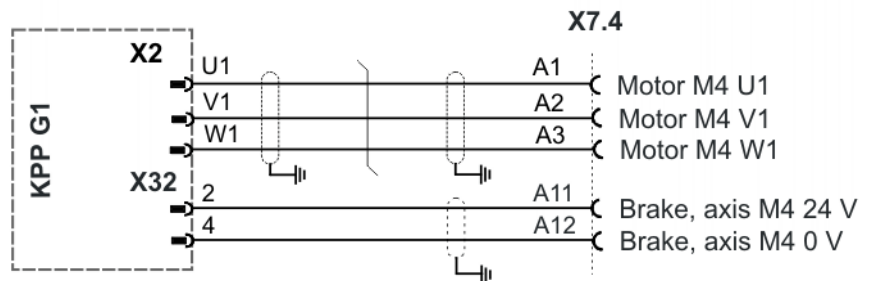

Fig. 1-36: Single connector X7.4

1.18.3 Connector pin allocation X7.1 to X7.5 (5 axes)

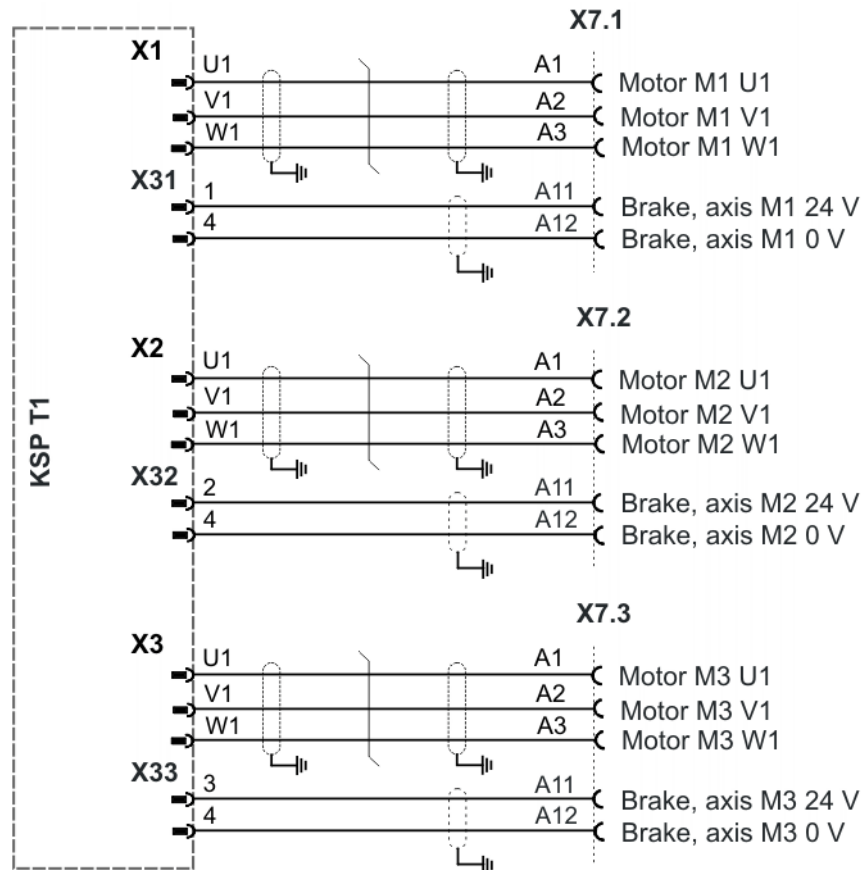

Fig. 1-37: Single connectors X7.1 to X7.3

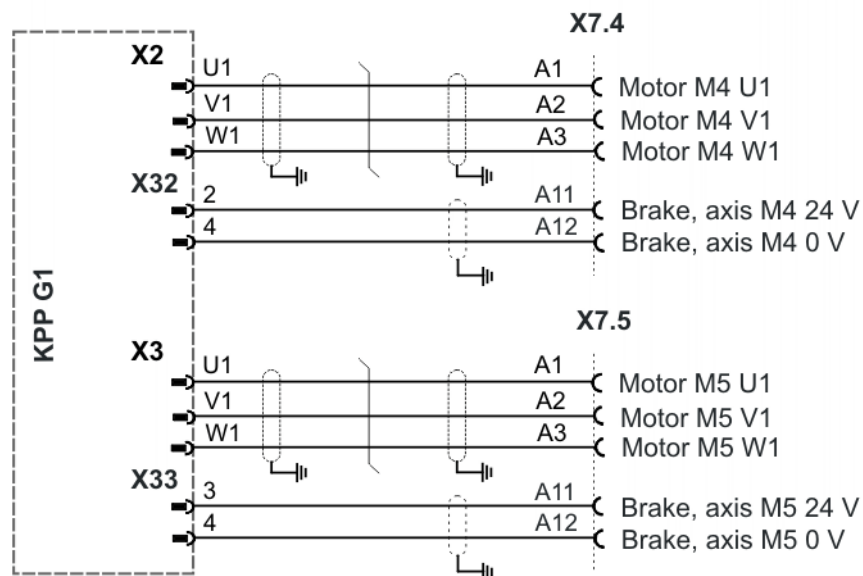

Fig. 1-38: Single connectors X7.4 and X7.5

1.18.4 Connector pin allocation X7.1 to X7.6 (6 axes)

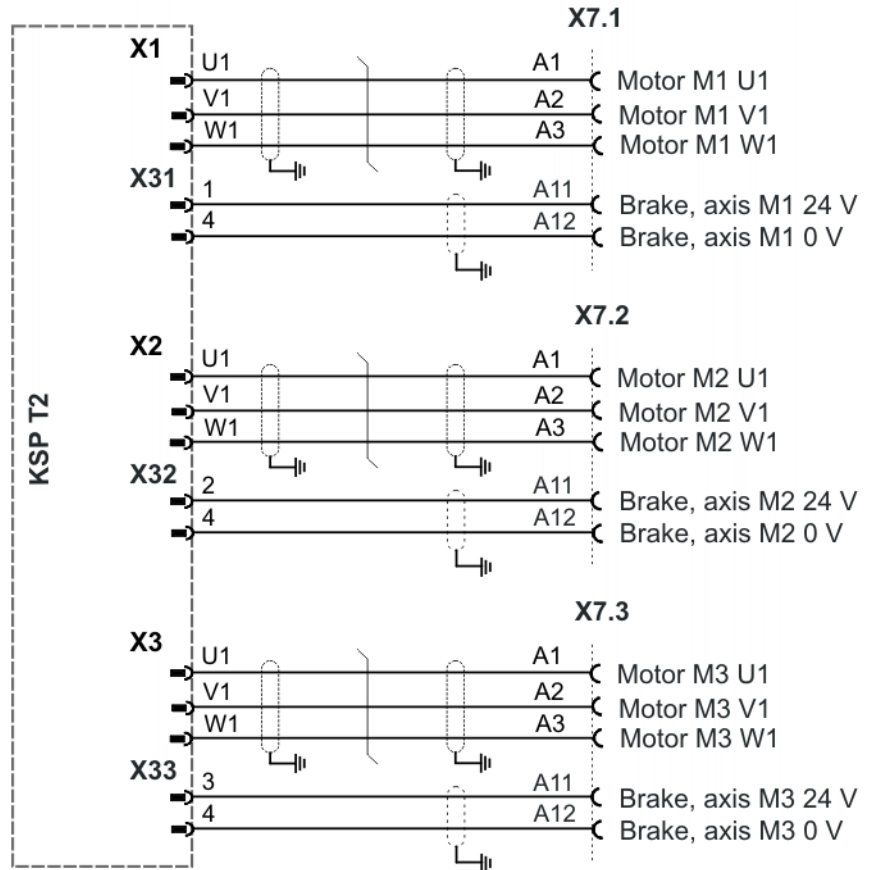

Fig. 1-39: Single connectors X7.1 to X7.3

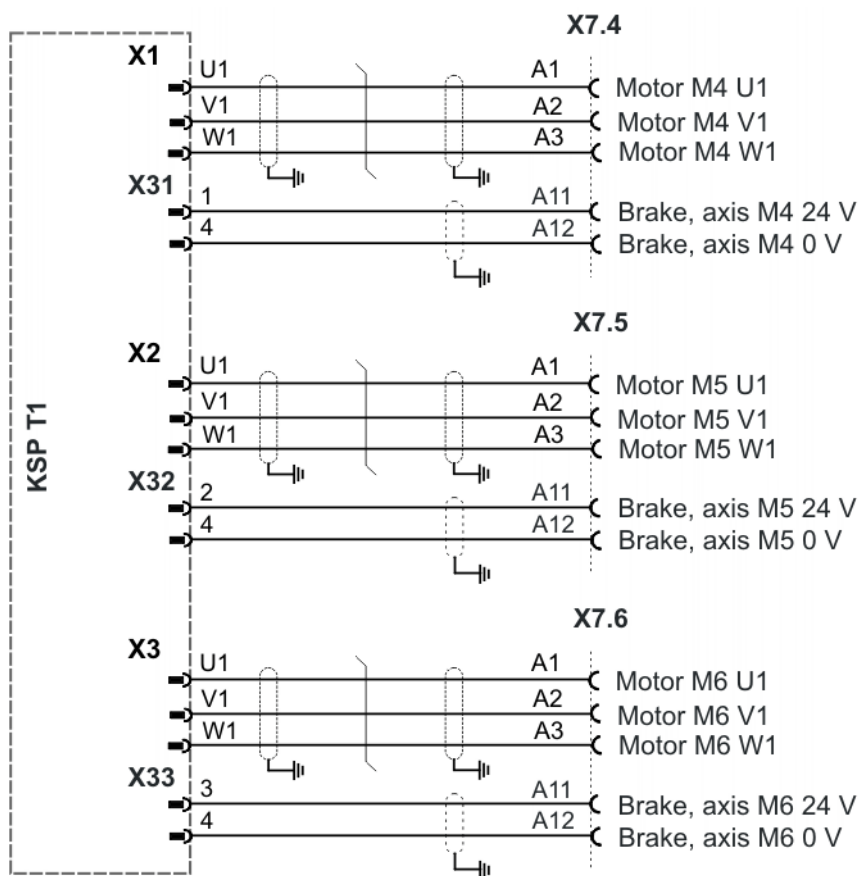

Fig. 1-40: Single connectors X7.4 to X7.6

1.18.5 Connector pin allocation X7.1 to X7.7 (7 axes)

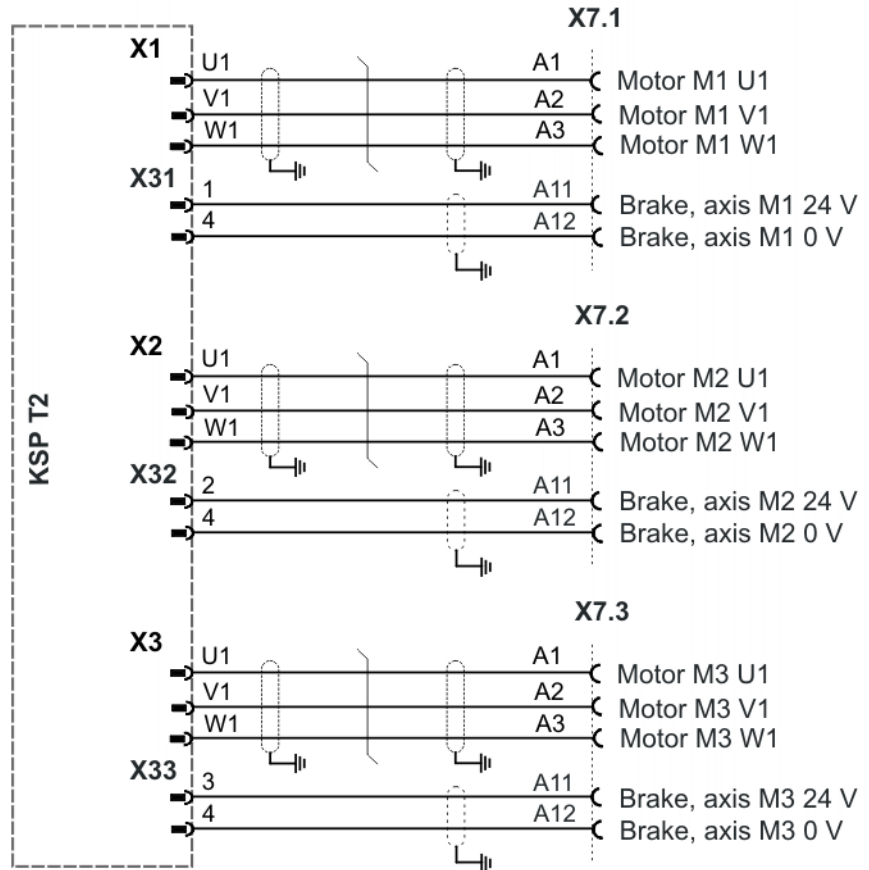

Fig. 1-41: Single connectors X7.1 to X7.3

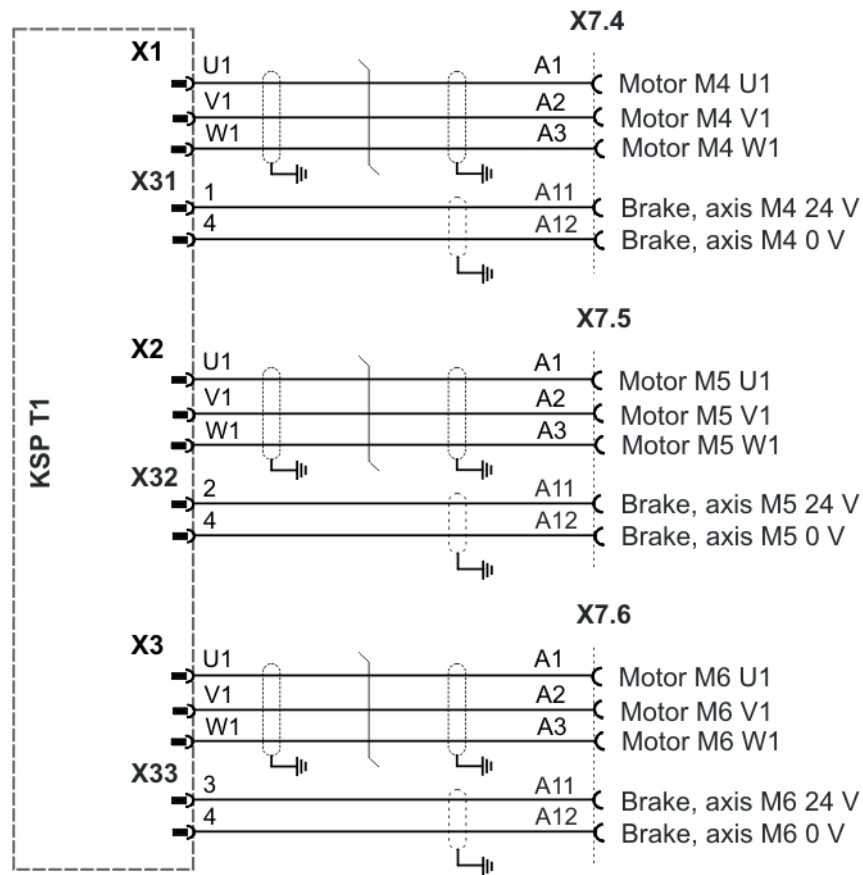

Fig. 1-42: Single connectors X7.4 to X7.6

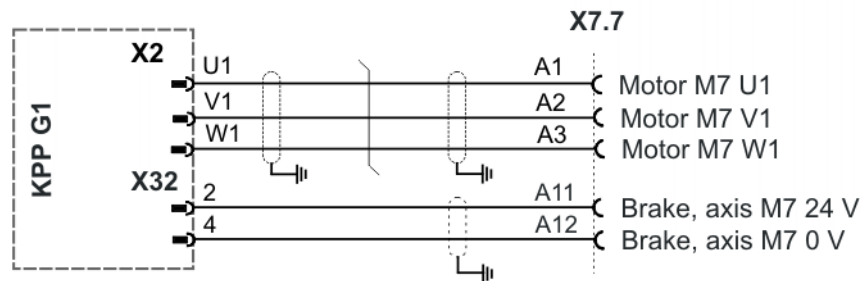

Fig. 1-43: Single connector X7.7

1.18.6 Connector pin allocation X7.1 to X7.8 (8 axes)

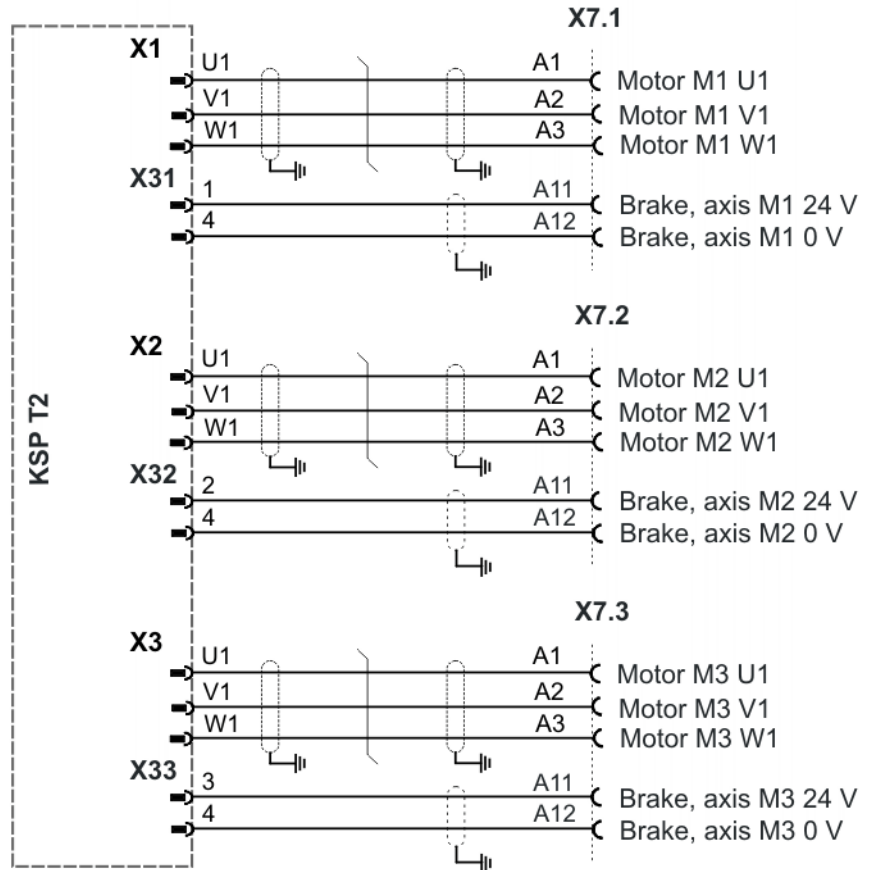

Fig. 1-44: Single connectors X7.1 to X7.3

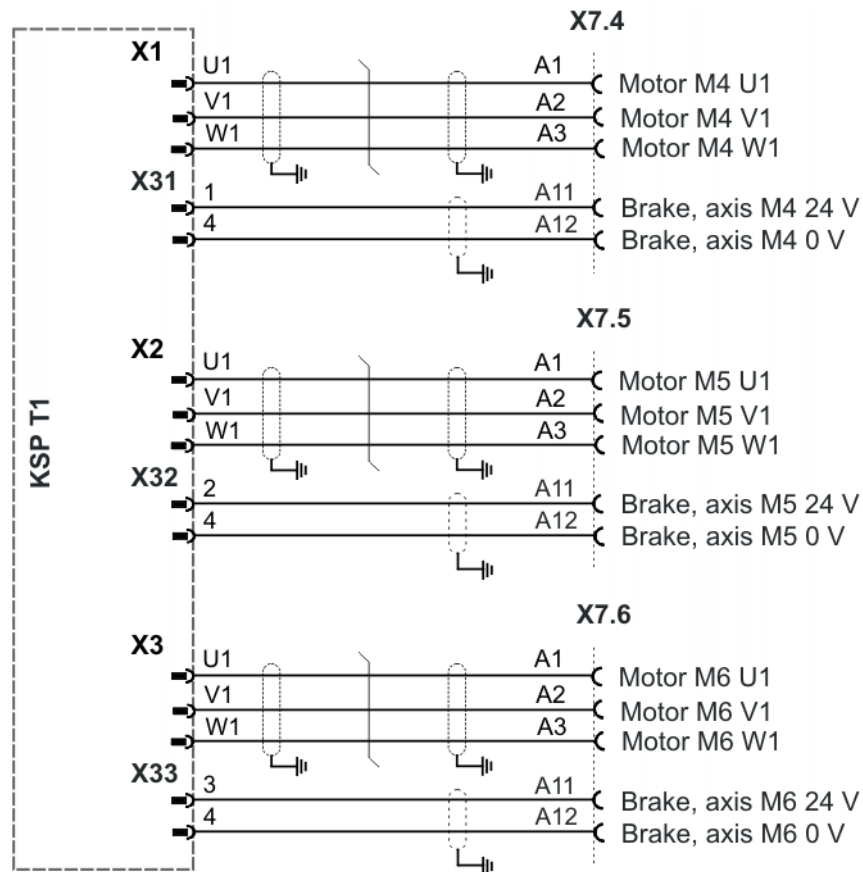

Fig. 1-45: Single connectors X7.4 to X7.6

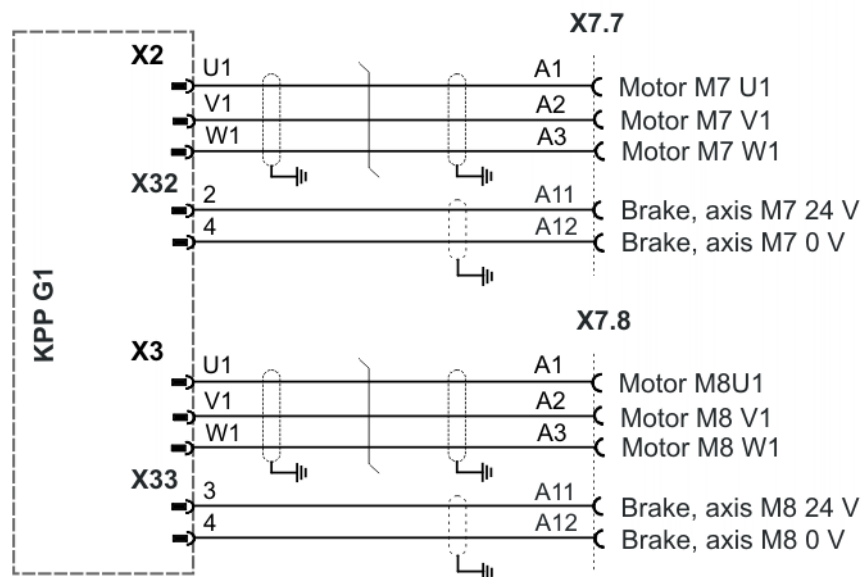

Fig. 1-46: Single connectors X7.7 and X7.8

1.19 Control PC interfaces

Motherboards

The following motherboard variants can be installed in the control PC:

- D2608-K
- D3076-K
- D3236-K

1.19.1 Motherboard D2608-K interfaces

Overview

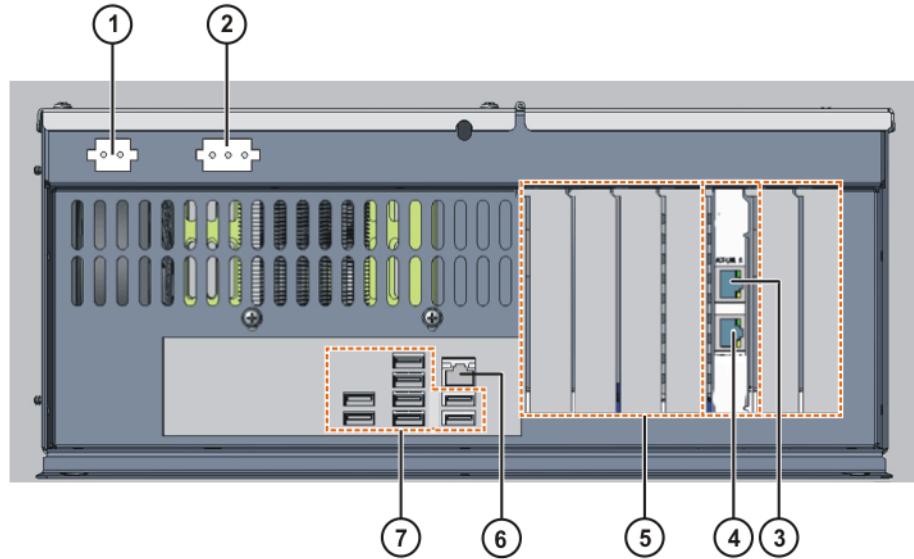

Fig. 1-47: Motherboard D2608-K interfaces

- 1 Connector X961, power supply DC 24 V
- 2 Connector X962, PC fan
- 3 LAN Dual NIC – KUKA Controller Bus
- 4 LAN Dual NIC – KUKA Line Interface
- 5 Field bus cards, slots 1 to 7
- 6 LAN Onboard – KUKA System Bus
- 7 8 USB 2.0 ports

i KUKA Roboter GmbH has assembled, tested and supplied the motherboard with an optimum configuration. No liability will be accepted for modifications to the configuration that have not been carried out by KUKA Roboter GmbH.

Slot assignment

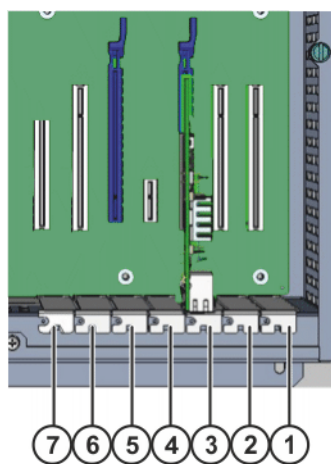

Fig. 1-48: Slot assignment, motherboard D2608-K

Slot	Type	Plug-in card
1	PCI	Field bus
2	PCI	Field bus
3	PCIe	LAN Dual NIC

Slot	Type	Plug-in card
4	PCIe	Not assigned
5	PCIe	Not assigned
6	PCI	Field bus
7	PCIe	Not assigned

1.19.2 Motherboard D3076-K interfaces

Overview

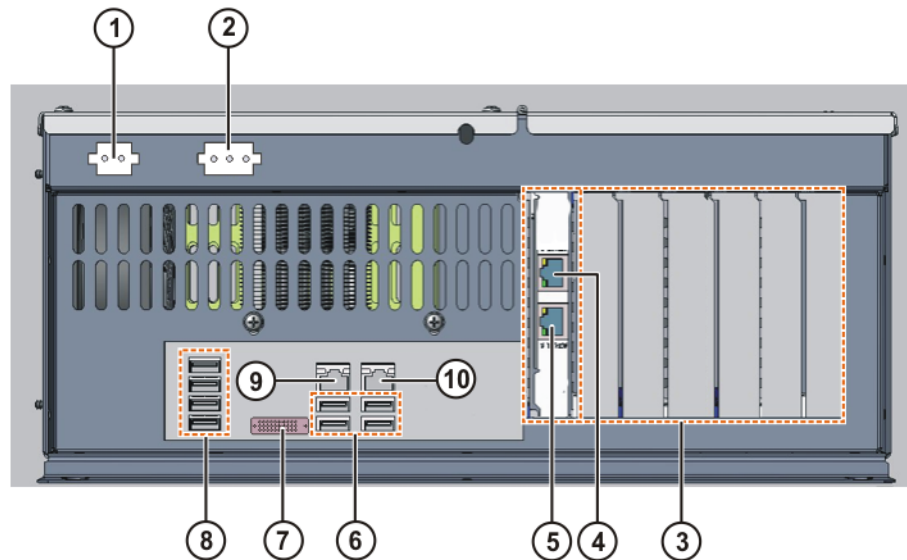

Fig. 1-49: Motherboard D3076-K interfaces

- 1 Connector X961, power supply DC 24 V
- 2 Connector X962, PC fan
- 3 Field bus cards, slots 1 to 7
- 4 LAN Dual NIC – KUKA Controller Bus
- 5 LAN Dual NIC – KUKA System Bus
- 6 4 USB 2.0 ports
- 7 DVI-I (VGA support possible via DVI on VGA adapter). The user interface of the controller can only be displayed on an external monitor if no active operator control device (smartPAD, VRP) is connected to the controller.
- 8 4 USB 2.0 ports
- 9 LAN Onboard – KUKA Option Network Interface.
- 10 LAN Onboard – KUKA Line Interface



KUKA Roboter GmbH has assembled, tested and supplied the motherboard with an optimum configuration. No liability will be accepted for modifications to the configuration that have not been carried out by KUKA Roboter GmbH.

Slot assignment

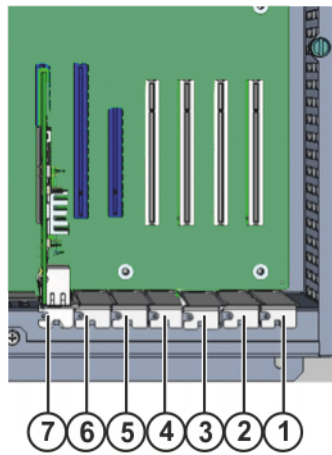

Fig. 1-50: Slot assignment, motherboard D3076-K

Slot	Type	Plug-in card
1	PCI	Field bus
2	PCI	Field bus
3	PCI	Field bus
4	PCI	Field bus
5	PCIe	Not assigned
6	PCIe	Not assigned
7	PCIe	LAN Dual NIC network card

1.19.3 Motherboard D3236-K interfaces

Overview

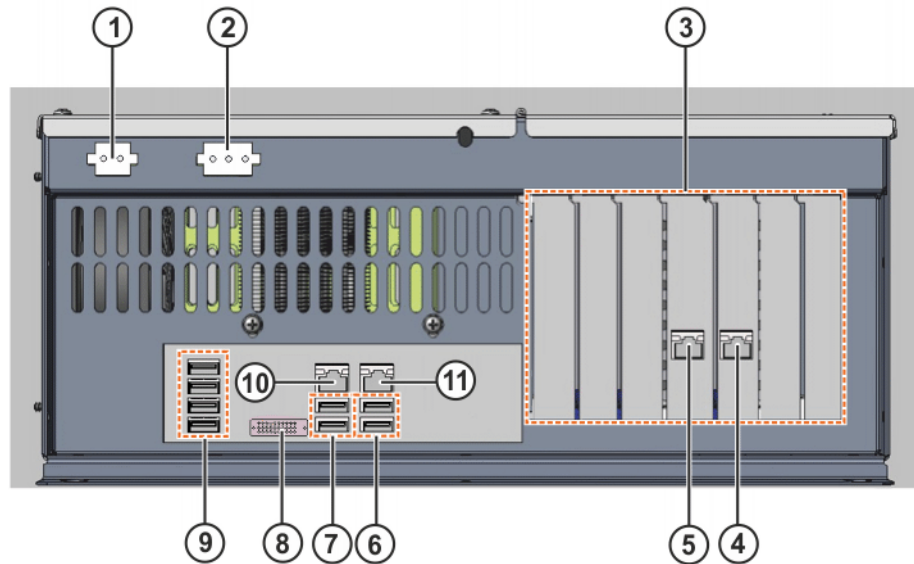

Fig. 1-51: Motherboard D3236-K interfaces

- 1 Connector X961, power supply DC 24 V
- 2 Connector X962, PC fan
- 3 Field bus cards, slots 1 to 7
- 4 LAN Onboard – KUKA Controller Bus
- 5 LAN Onboard – KUKA System Bus
- 6 2 USB 2.0 ports
- 7 2 USB 3.0 ports

- 8 DVI-I (VGA support possible via DVI on VGA adapter). The user interface of the controller can only be displayed on an external monitor if no active operator control device (smartPAD, VRP) is connected to the controller.
- 9 4 USB 2.0 ports
- 10 LAN Onboard – KUKA Option Network Interface.
- 11 LAN Onboard – KUKA Line Interface

i KUKA Roboter GmbH has assembled, tested and supplied the motherboard with an optimum configuration. No liability will be accepted for modifications to the configuration that have not been carried out by KUKA Roboter GmbH.

Slot assignment

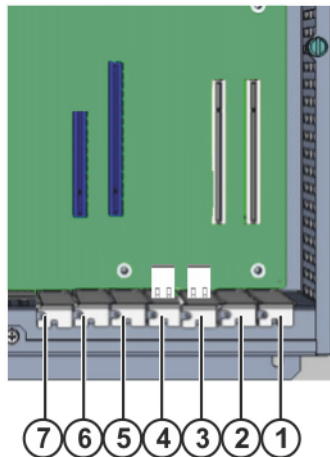

Fig. 1-52: Slot assignment, motherboard D3236-K

Slot	Type	Plug-in card
1	PCI	Field bus
2	PCI	Field bus
3	-	Not available
4	-	Not available
5	PCIe	Not assigned
6	PCIe	Not assigned
7	-	Not available

1.20 KUKA smartPAD holder (optional)

Description

The optional KUKA smartPAD holder can be used to hang up the smartPAD and its connecting cable on the door of the robot controller or on the safety fence.

Overview

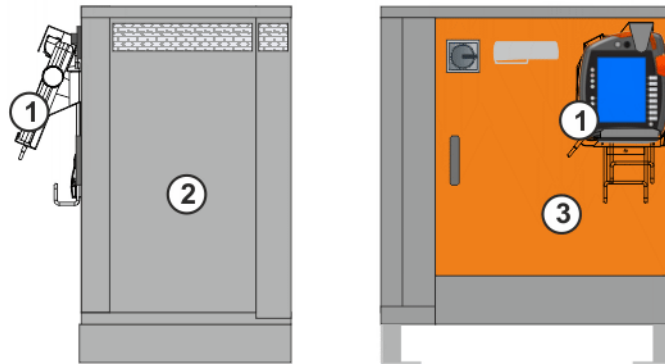

Fig. 1-53: KUKA smartPAD holder

- 1 KUKA smartPAD holder
- 2 Side view
- 3 Front view

1.21 Transient limiter

Description

The transient limiter is a surge voltage protector and consists of a base module and a plugged-on protection module.

1.22 Cabinet cooling

Description

The control cabinet is divided into two cooling circuits. The inner zone, containing the control and power electronics, is cooled by a heat exchanger. In the outer zone, the ballast resistor and the heat sinks of the KPP and KSP are cooled directly by ambient air.

NOTICE Upstream installation of filter mats at the ventilation slits causes an increase in temperature, leading to a reduction in the service life of the installed devices!

Configuration

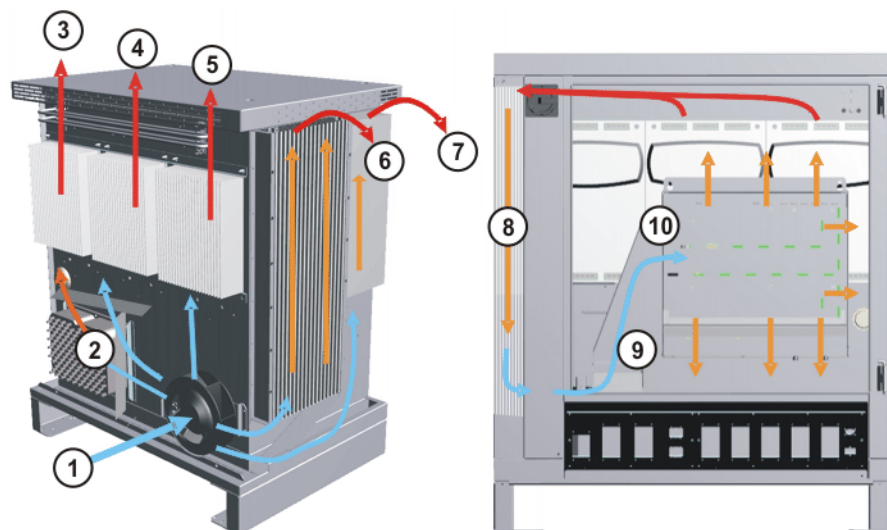

Fig. 1-54: Cooling circuits

- 1 Air inlet, external fan
- 2 Heat sink, low-voltage power supply
- 3 Air outlet, KPP
- 4
- 5
- 6 Air outlet, heat exchanger
- 7 Air outlet, mains filter
- 8 Heat exchanger
- 9
- 10

- | | | | |
|---|-----------------|----|-----------------|
| 4 | Air outlet, KSP | 9 | KPC intake duct |
| 5 | Air outlet, KSP | 10 | PC fan |

1.23 Description of the space for integration of customer options

Overview

The space for integration of customer options can be used for external customer equipment depending on the installed hardware options on the top-hat rail.

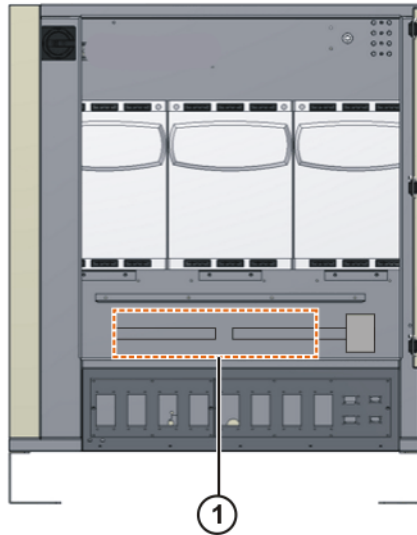

Fig. 1-55: Mounting plate for customer components

- 1 Space for integration of customer options

2 Technical data

Basic data

Cabinet type	KR C4
Number of axes	max. 8
Weight (without transformer)	150 kg
Protection classification	IP 54
Sound level according to DIN 45635-1	average: 67 dB (A)
Installation with other cabinets (with/without cooling unit)	Side-by-side, clearance 50 mm
Load on cabinet roof with even distribution	1,500 N

Power supply connection

⚠ CAUTION	If the robot controller is connected to a power system without a grounded neutral or is operated with incorrect machine data, this may cause malfunctions in the robot controller and material damage to the power supply units. Electrical voltage can cause injuries. The robot controller may only be operated with grounded-neutral power supply systems.
------------------	---

If no grounded neutral is available, or if the mains voltage differs from those specified here, a transformer must be used.

Rated supply voltage according to the machine data, optionally:	AC 3x380 V, AC 3x400 V, AC 3x440 V or AC 3x480 V
Permissible tolerance of rated supply voltage	Rated supply voltage $\pm 10\%$
Mains frequency	49 ... 61 Hz
System impedance up to the connection point of the robot controller	$\leq 300 \text{ m}\Omega$
Full-load current	See identification plate
Mains-side fusing without transformer	min. 3x25 A, slow-blowing
Mains-side fusing with transformer	min. 3x32 A, slow-blowing, with 13 kVA
Equipotential bonding	The common neutral point for the equipotential bonding conductors and all protective ground conductors is the reference bus of the power unit.

Environmental conditions

Ambient temperature during operation without cooling unit	+5 ... 45 °C (278 ... 318 K)
Ambient temperature during operation with cooling unit	+20 ... 50 °C (293 ... 323 K)
Ambient temperature during storage/transportation with batteries	-25 ... +40 °C (248 ... 313 K)
Ambient temperature during storage/transportation without batteries	-25 ... +70 °C (248 ... 343 K)
Temperature change	max. 1.1 K/min

Humidity class	3k3 acc. to DIN EN 60721-3-3; 1995
Altitude	<ul style="list-style-type: none"> ■ up to 1000 m above mean sea level with no reduction in power ■ 1000 m ... 4000 m above mean sea level with a reduction in power of 5%/1000 m

NOTICE To prevent exhaustive discharge and thus destruction of the batteries, the batteries must be recharged at regular intervals according to the storage temperature.
 If the storage temperature is +20 °C or lower, the batteries must be recharged every 9 months.
 If the storage temperature is between +20 °C and +30 °C, the batteries must be recharged every 6 months.
 If the storage temperature is between +30 °C and +40 °C, the batteries must be recharged every 3 months.

Vibration resistance

Type of loading	During transportation	During continuous operation
r.m.s. acceleration (sustained oscillation)	0.37 g	0.1 g
Frequency range (sustained oscillation)	4 to 120 Hz	
Acceleration (shock in X/Y/Z direction)	10 g	2.5 g
Waveform/duration (shock in X/Y/Z direction)	Half-sine/11 ms	

If more severe mechanical stress is expected, the controller must be installed on anti-vibration components.

Control unit

Supply voltage	DC 27.1 V ± 0.1 V
----------------	-------------------

Control PC

Main processor	See shipping version
DIMM memory modules	See shipping version (min. 2 GB)
Hard disk	See shipping version

KUKA smartPAD

Supply voltage	20 ... 27.1 V DC
Dimensions (WxHxD)	approx. 33x26x8 cm ³
Display	Touch-sensitive color display 600x800 pixels
Display size	8,4 "
Interfaces	USB
Weight	1.1 kg
Protection rating (without USB stick and USB connection closed with a plug)	IP 54

Space for integration of customer options

Designation	Values
Power dissipation of installed components	max. 20 W
Depth of installed components	approx. 200 mm

Designation	Values
Width	300 mm
Height	150 mm

Cable lengths

For cable designations, standard lengths and optional lengths, please refer to the operating instructions or assembly instructions of the manipulator and/or the assembly and operating instructions for KR C4 external cabling for robot controllers.



When using smartPAD cable extensions, only two extensions may be used. An overall cable length of 50 m must not be exceeded.



The difference in the cable lengths between the individual channels of the RDC box must not exceed 10 m.

2.1 External 24 V power supply

PELV external power supply

External voltage	PELV power supply unit acc. to EN 60950 with rated voltage 27 V (18 V ... 30 V), safely isolated
Continuous current	> 8 A
Cable cross-section of power supply cable	$\geq 1 \text{ mm}^2$
Cable length of power supply cable	< 50 m, or < 100 m wire length (outgoing and incoming lines)



The cables of the power supply unit must not be routed together with power-carrying cables.



The minus connection of the external voltage must be grounded by the customer.



Parallel connection of a basic-insulated device is not permitted.

2.2 Safety Interface Board

SIB outputs



The power contacts must only be fed from a safely isolated PELV power supply unit. (>>> 2.1 "External 24 V power supply" Page 55)

Operating voltage, power contacts	$\leq 30 \text{ V}$
Current via power contact	min. 10 mA < 750 mA
Cable lengths (connection of actuators)	< 50 m cable lengths < 100 m wire length (outgoing and incoming lines)
Cable cross-section (connection of actuators)	$\geq 1 \text{ mm}^2$

Switching cycles, Standard SIB	Service life: 20 years < 100,000 (corresponds to 13 switching cycles per day)
Switching cycles, Extended SIB	Service life: 20 years < 780,000 (corresponds to 106 switching cycles per day)

The module must be exchanged when the number of switching cycles is exceeded.

SIB inputs

Switching level of the inputs	The state for the inputs is not defined for the voltage range from 5 V to 11 V (transition range). Either the ON state or the OFF state is set. OFF state for the voltage range from -3 V to 5 V (OFF range). ON state for the voltage range from 11 V to 30 V (ON range).
Load current with 24 V supply voltage	> 10 mA
Load current with 18 V supply voltage	> 6.5 mA
Max. load current	< 15 mA
Cable length, terminal - sensor	< 50 m, or < 100 m wire length (outgoing and incoming lines)
Cable cross-section, test output - input connection	> 0.5 mm ²
Capacitive load for the test outputs per channel	< 200 nF
Resistive load for the test outputs per channel	< 33 Ω



Test outputs A and B are sustained short-circuit proof. The specified currents flow via the contact element connected to the input. This must be rated for the maximum current of 15 mA.

2.3 Dimensions of robot controller

The dimensions of the robot controller are indicated in the diagram (>>> Fig. 2-1).

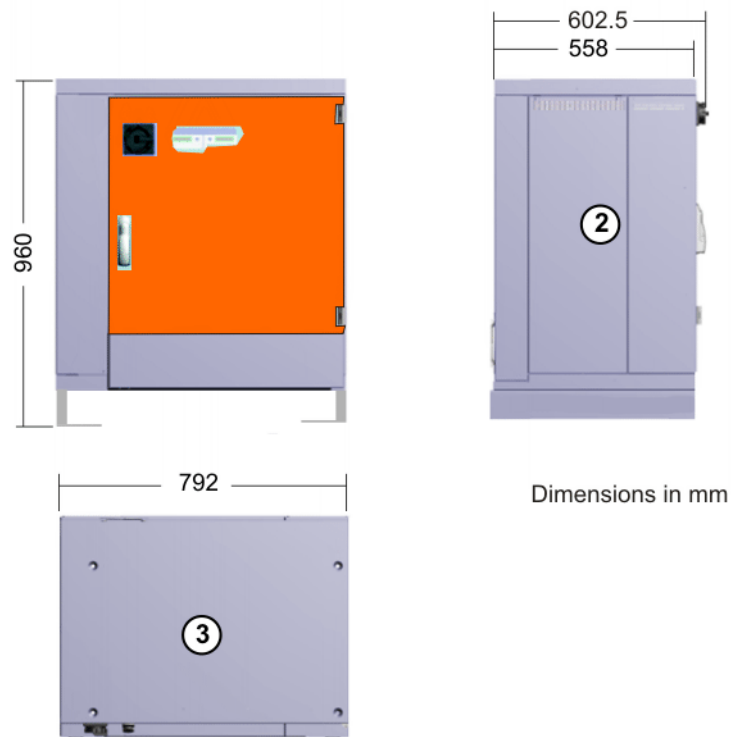

Fig. 2-1: Dimensions

- 1 Front view
- 2 Side view
- 3 Top view

2.4 Minimum clearances, robot controller

The minimum clearances that must be maintained for the robot controller are indicated in the diagram (>>> Fig. 2-2).

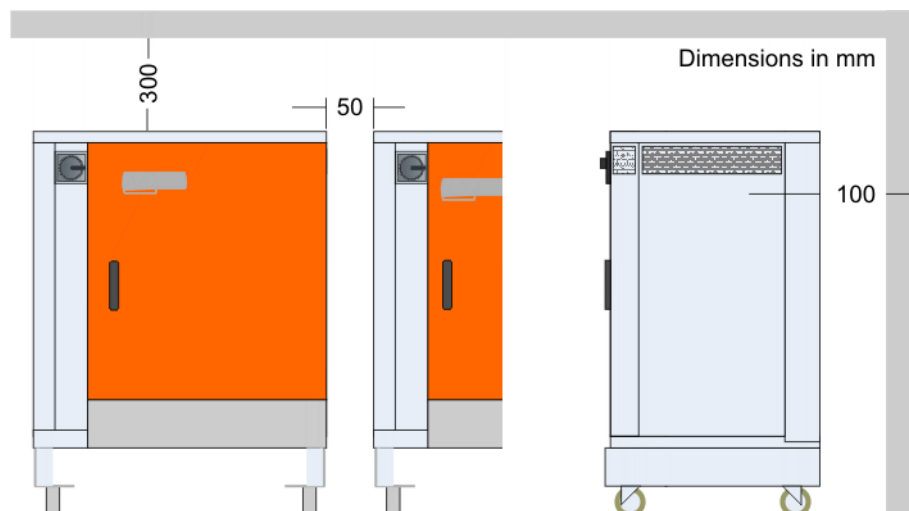

Fig. 2-2: Minimum clearances

NOTICE If the minimum clearances are not maintained, this can result in damage to the robot controller. The specified minimum clearances must always be observed.

i Certain maintenance and repair tasks on the robot controller must be carried out from the side or from the rear. The robot controller must be accessible for this. If the side or rear panels are not accessible, it must be possible to move the robot controller into a position in which the work can be carried out.

2.5 Swing range for cabinet door

The diagram (>>> Fig. 2-3) shows the swing range for the door.

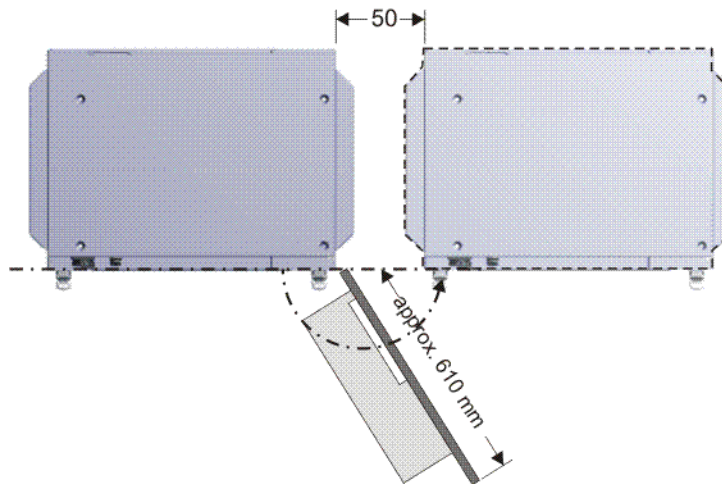

Fig. 2-3: Swing range for cabinet door

Swing range, standalone cabinet:

- Door with computer frame approx. 180°

Swing range, butt-mounted cabinets:

- Door approx. 155°

2.6 Dimensions of the smartPAD holder (optional)

The diagram (>>> Fig. 2-4) shows the dimensions and drilling locations for mounting on the robot controller or safety fence.

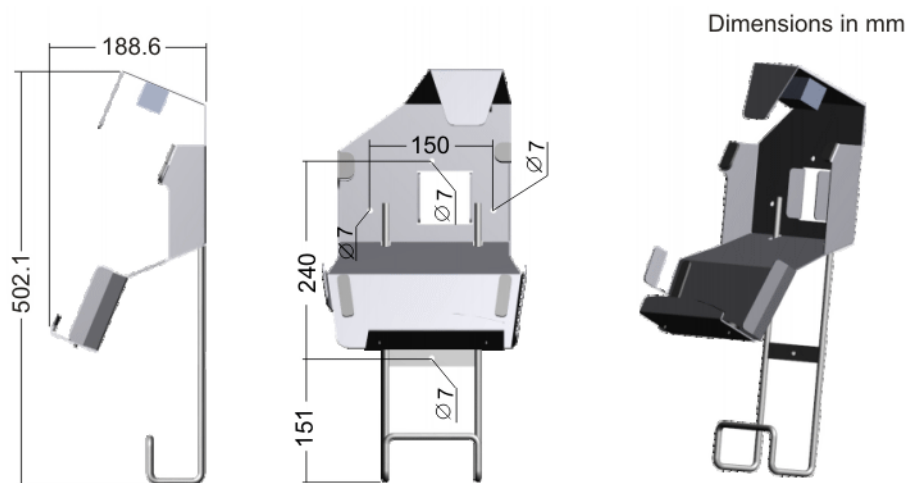

Fig. 2-4: Dimensions and drilling locations for smartPAD holder

2.7 Dimensions of boreholes for floor mounting

The dimensions of the boreholes for floor mounting are indicated in the diagram (>>> Fig. 2-5).

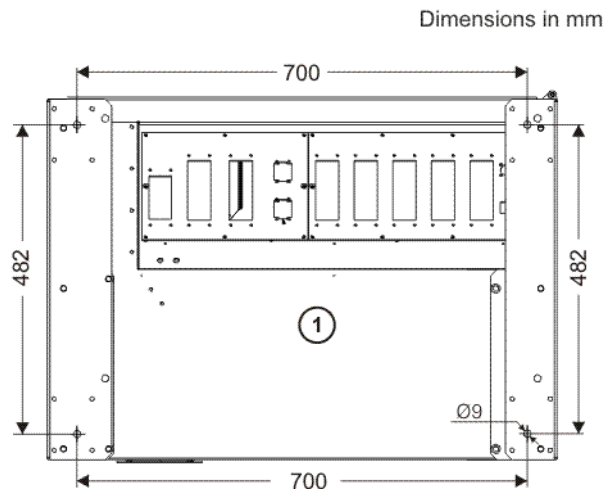

Fig. 2-5: Boreholes for floor mounting

1 View from below

2.8 Plates and labels

Overview

The following plates and labels are attached to the robot controller.

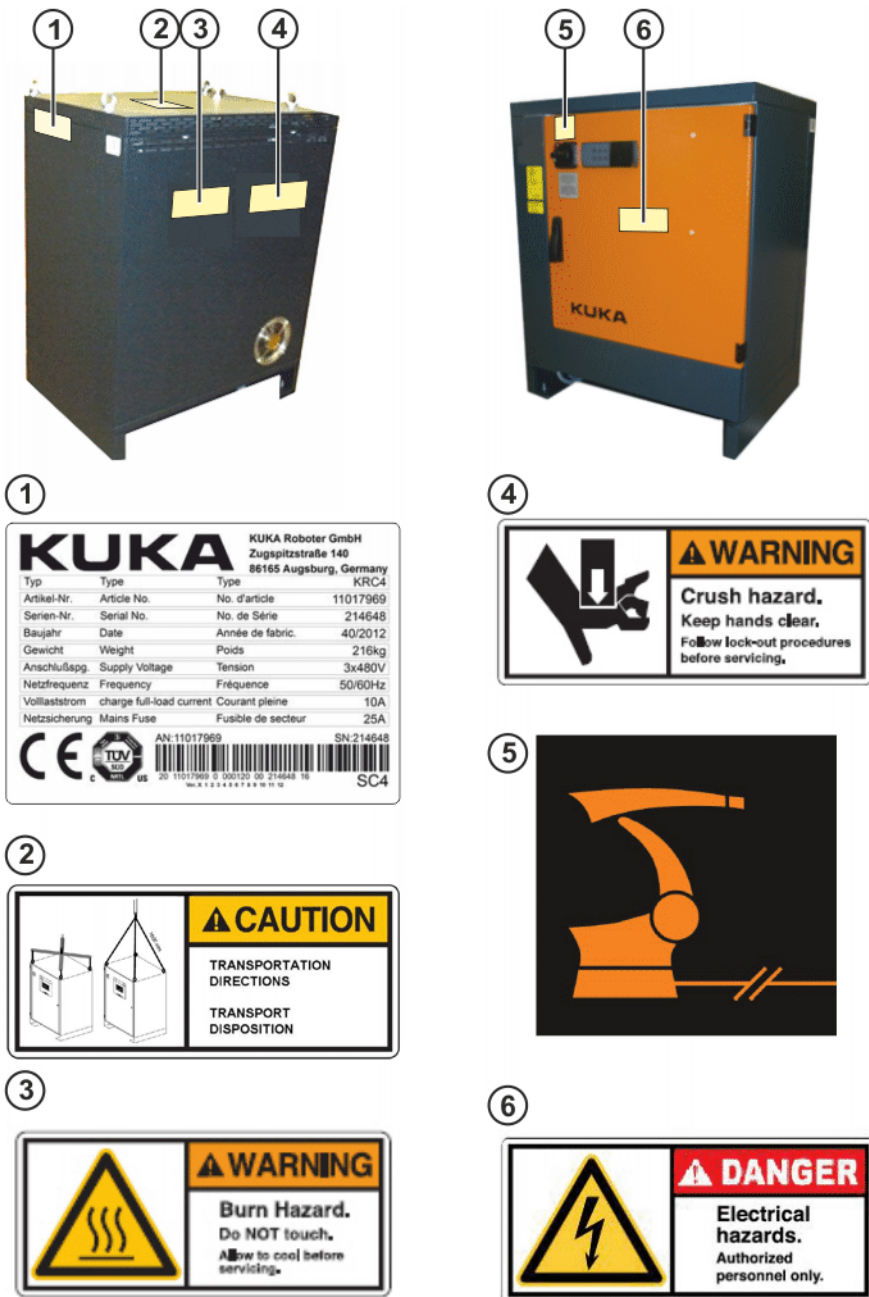
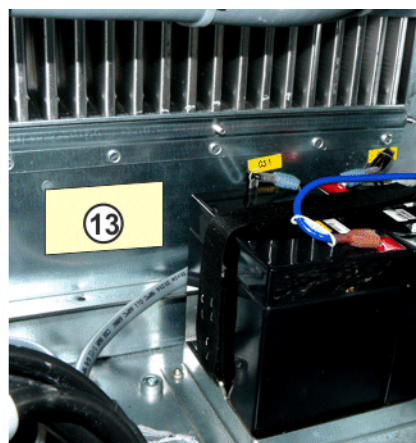
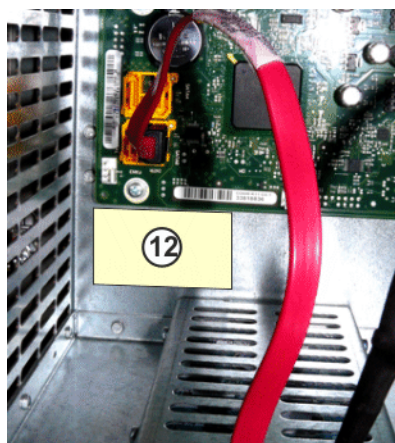

Fig. 2-6: Plates and labels, part 1



Fig. 2-7: Plates and labels, part 2



⑫ PC-BATTERY REPLACE WITH
 PILE POUR ORDINATEUR
 REMPLACEZ PAR:
 PRE CR 2032 3V

⑬ REPLACE WITH:
 REMPLACEZ PAR:
 0000115723

Fig. 2-8: Plates and labels, part 3

i The plates may vary slightly from the examples illustrated above depending on the specific cabinet type or as a result of updates.

Designations

Plate no.	Designation
1	Robot controller rating plate
2	Caution: Transportation
3	Hot surface warning sign
4	Hand injury warning sign
5	Sign: KR C4 main switch
6	Danger: Electrical hazards
7	Danger: Arc flash hazard
8	Warning: Voltage/current, SCCR value
9	Danger: ≤ 780 VDC / wait 180 s
10	Danger: read manual
11	Control PC rating plate
12	Sign: PC battery change
13	Sign: Battery change

3 Safety

3.1 General

3.1.1 Liability

The device described in this document is either an industrial robot or a component thereof.

Components of the industrial robot:

- Manipulator
- Robot controller
- Teach pendant
- Connecting cables
- External axes (optional)
e.g. linear unit, turn-tilt table, positioner
- Software
- Options, accessories

The industrial robot is built using state-of-the-art technology and in accordance with the recognized safety rules. Nevertheless, misuse of the industrial robot may constitute a risk to life and limb or cause damage to the industrial robot and to other material property.

The industrial robot may only be used in perfect technical condition in accordance with its designated use and only by safety-conscious persons who are fully aware of the risks involved in its operation. Use of the industrial robot is subject to compliance with this document and with the declaration of incorporation supplied together with the industrial robot. Any functional disorders affecting safety must be rectified immediately.

Safety information

Safety information cannot be held against KUKA Roboter GmbH. Even if all safety instructions are followed, this is not a guarantee that the industrial robot will not cause personal injuries or material damage.

No modifications may be carried out to the industrial robot without the authorization of KUKA Roboter GmbH. Additional components (tools, software, etc.), not supplied by KUKA Roboter GmbH, may be integrated into the industrial robot. The user is liable for any damage these components may cause to the industrial robot or to other material property.

In addition to the Safety chapter, this document contains further safety instructions. These must also be observed.

3.1.2 Intended use of the industrial robot

The industrial robot is intended exclusively for the use designated in the "Purpose" chapter of the operating instructions or assembly instructions.

Any use or application deviating from the intended use is deemed to be misuse and is not allowed. The manufacturer is not liable for any damage resulting from such misuse. The risk lies entirely with the user.

Operation of the industrial robot in accordance with its intended use also requires compliance with the operating and assembly instructions for the individual components, with particular reference to the maintenance specifications.

Misuse

Any use or application deviating from the intended use is deemed to be misuse and is not allowed. This includes e.g.:

- Transportation of persons and animals
- Use as a climbing aid
- Operation outside the specified operating parameters
- Use in potentially explosive environments
- Operation without additional safeguards
- Outdoor operation
- Underground operation

3.1.3 EC declaration of conformity and declaration of incorporation

The industrial robot constitutes partly completed machinery as defined by the EC Machinery Directive. The industrial robot may only be put into operation if the following preconditions are met:

- The industrial robot is integrated into a complete system.
Or: The industrial robot, together with other machinery, constitutes a complete system.
Or: All safety functions and safeguards required for operation in the complete machine as defined by the EC Machinery Directive have been added to the industrial robot.
- The complete system complies with the EC Machinery Directive. This has been confirmed by means of an assessment of conformity.

Declaration of conformity

The system integrator must issue a declaration of conformity for the complete system in accordance with the Machinery Directive. The declaration of conformity forms the basis for the CE mark for the system. The industrial robot must always be operated in accordance with the applicable national laws, regulations and standards.

The robot controller is CE certified under the EMC Directive and the Low Voltage Directive.

Declaration of incorporation

The industrial robot as partly completed machinery is supplied with a declaration of incorporation in accordance with Annex II B of the EC Machinery Directive 2006/42/EC. The assembly instructions and a list of essential requirements complied with in accordance with Annex I are integral parts of this declaration of incorporation.

The declaration of incorporation declares that the start-up of the partly completed machinery is not allowed until the partly completed machinery has been incorporated into machinery, or has been assembled with other parts to form machinery, and this machinery complies with the terms of the EC Machinery Directive, and the EC declaration of conformity is present in accordance with Annex II A.

3.1.4 Terms used

STOP 0, STOP 1 and STOP 2 are the stop definitions according to EN 60204-1:2006.

Term	Description
Axis range	Range of each axis, in degrees or millimeters, within which it may move. The axis range must be defined for each axis.
Stopping distance	Stopping distance = reaction distance + braking distance The stopping distance is part of the danger zone.
Workspace	Area within which the robot may move. The workspace is derived from the individual axis ranges.

Term	Description
User	The user of the industrial robot can be the management, employer or delegated person responsible for use of the industrial robot.
Danger zone	The danger zone consists of the workspace and the stopping distances of the manipulator and external axes (optional).
Service life	The service life of a safety-relevant component begins at the time of delivery of the component to the customer. The service life is not affected by whether the component is used or not, as safety-relevant components are also subject to aging during storage.
KUKA smartPAD	see "smartPAD"
Manipulator	The robot arm and the associated electrical installations
Safety zone	The safety zone is situated outside the danger zone.
Safe operational stop	The safe operational stop is a standstill monitoring function. It does not stop the robot motion, but monitors whether the robot axes are stationary. If these are moved during the safe operational stop, a safety stop STOP 0 is triggered. The safe operational stop can also be triggered externally. When a safe operational stop is triggered, the robot controller sets an output to the field bus. The output is set even if not all the axes were stationary at the time of triggering, thereby causing a safety stop STOP 0 to be triggered.
Safety STOP 0	A stop that is triggered and executed by the safety controller. The safety controller immediately switches off the drives and the power supply to the brakes. Note: This stop is called safety STOP 0 in this document.
Safety STOP 1	A stop that is triggered and monitored by the safety controller. The braking process is performed by the non-safety-oriented part of the robot controller and monitored by the safety controller. As soon as the manipulator is at a standstill, the safety controller switches off the drives and the power supply to the brakes. When a safety STOP 1 is triggered, the robot controller sets an output to the field bus. The safety STOP 1 can also be triggered externally. Note: This stop is called safety STOP 1 in this document.
Safety STOP 2	A stop that is triggered and monitored by the safety controller. The braking process is performed by the non-safety-oriented part of the robot controller and monitored by the safety controller. The drives remain activated and the brakes released. As soon as the manipulator is at a standstill, a safe operational stop is triggered. When a safety STOP 2 is triggered, the robot controller sets an output to the field bus. The safety STOP 2 can also be triggered externally. Note: This stop is called safety STOP 2 in this document.
Safety options	Generic term for options which make it possible to configure additional safe monitoring functions in addition to the standard safety functions. Example: SafeOperation
smartPAD	Teach pendant for the KR C4 The smartPAD has all the operator control and display functions required for operating and programming the industrial robot.

Term	Description
Stop category 0	The drives are deactivated immediately and the brakes are applied. The manipulator and any external axes (optional) perform path-oriented braking. Note: This stop category is called STOP 0 in this document.
Stop category 1	The manipulator and any external axes (optional) perform path-maintaining braking. <ul style="list-style-type: none"> ■ Operating mode T1: The drives are deactivated as soon as the robot has stopped, but no later than after 680 ms. ■ Operating mode T2, AUT, AUT EXT: The drives are switched off after 1.5 s. Note: This stop category is called STOP 1 in this document.
Stop category 2	The drives are not deactivated and the brakes are not applied. The manipulator and any external axes (optional) are braked with a path-maintaining braking ramp. Note: This stop category is called STOP 2 in this document.
System integrator (plant integrator)	The system integrator is responsible for safely integrating the industrial robot into a complete system and commissioning it.
T1	Test mode, Manual Reduced Velocity (≤ 250 mm/s)
T2	Test mode, Manual High Velocity (> 250 mm/s permissible)
External axis	Motion axis which is not part of the manipulator but which is controlled using the robot controller, e.g. KUKA linear unit, turn-tilt table, Posiflex.

3.2 Personnel

The following persons or groups of persons are defined for the industrial robot:

- User
- Personnel



All persons working with the industrial robot must have read and understood the industrial robot documentation, including the safety chapter.

User

The user must observe the labor laws and regulations. This includes e.g.:

- The user must comply with his monitoring obligations.
- The user must carry out instructions at defined intervals.

Personnel

Personnel must be instructed, before any work is commenced, in the type of work involved and what exactly it entails as well as any hazards which may exist. Instruction must be carried out regularly. Instruction is also required after particular incidents or technical modifications.

Personnel includes:

- System integrator
- Operators, subdivided into:
 - Start-up, maintenance and service personnel
 - Operating personnel
 - Cleaning personnel



Installation, exchange, adjustment, operation, maintenance and repair must be performed only as specified in the operating or assembly instructions for the relevant component of the industrial robot and only by personnel specially trained for this purpose.

System integrator The industrial robot is safely integrated into a complete system by the system integrator.

The system integrator is responsible for the following tasks:

- Installing the industrial robot
- Connecting the industrial robot
- Performing risk assessment
- Implementing the required safety functions and safeguards
- Issuing the declaration of conformity
- Attaching the CE mark
- Creating the operating instructions for the complete system

Operator

The operator must meet the following preconditions:

- The operator must be trained for the work to be carried out.
- Work on the industrial robot must only be carried out by qualified personnel. These are people who, due to their specialist training, knowledge and experience, and their familiarization with the relevant standards, are able to assess the work to be carried out and detect any potential hazards.



Work on the electrical and mechanical equipment of the industrial robot may only be carried out by specially trained personnel.

3.3 Workspace, safety zone and danger zone

Workspaces are to be restricted to the necessary minimum size. A workspace must be safeguarded using appropriate safeguards.

The safeguards (e.g. safety gate) must be situated inside the safety zone. In the case of a stop, the manipulator and external axes (optional) are braked and come to a stop within the danger zone.

The danger zone consists of the workspace and the stopping distances of the manipulator and external axes (optional). It must be safeguarded by means of physical safeguards to prevent danger to persons or the risk of material damage.

3.4 Triggers for stop reactions

Stop reactions of the industrial robot are triggered in response to operator actions or as a reaction to monitoring functions and error messages. The following table shows the different stop reactions according to the operating mode that has been set.

Trigger	T1, T2	AUT, AUT EXT
Start key released	STOP 2	-
STOP key pressed	STOP 2	
Drives OFF	STOP 1	
"Motion enable" input drops out	STOP 2	
Power switched off via main switch or power failure	STOP 0	
Internal error in non-safety-oriented part of the robot controller	STOP 0 or STOP 1 (dependent on the cause of the error)	

Trigger	T1, T2	AUT, AUT EXT
Operating mode changed during operation	Safety stop 2	
Safety gate opened (operator safety)	-	Safety stop 1
Enabling switch released	Safety stop 2	-
Enabling switch pressed fully down or error	Safety stop 1	-
E-STOP pressed	Safety stop 1	
Error in safety controller or periphery of the safety controller	Safety stop 0	

3.5 Safety functions

3.5.1 Overview of the safety functions

The following safety functions are present in the industrial robot:

- Mode selection
- Operator safety (= connection for the guard interlock)
- EMERGENCY STOP device
- Enabling device
- External safe operational stop
- External safety stop 1 (not for the controller variant "KR C4 compact")
- External safety stop 2
- Velocity monitoring in T1

The safety functions of the industrial robot meet the following requirements:

- **Category 3** and **Performance Level d** in accordance with EN ISO 13849-1:2008

The requirements are only met on the following condition, however:

- The EMERGENCY STOP device is pressed at least once every 6 months.

The following components are involved in the safety functions:

- Safety controller in the control PC
- KUKA smartPAD
- Cabinet Control Unit (CCU)
- Resolver Digital Converter (RDC)
- KUKA Power Pack (KPP)
- KUKA Servo Pack (KSP)
- Safety Interface Board (SIB) (if used)

There are also interfaces to components outside the industrial robot and to other robot controllers.

 DANGER	<p>In the absence of operational safety functions and safeguards, the industrial robot can cause personal injury or material damage. If safety functions or safeguards are dismantled or deactivated, the industrial robot may not be operated.</p>
---	---



During system planning, the safety functions of the overall system must also be planned and designed. The industrial robot must be integrated into this safety system of the overall system.

3.5.2 Safety controller

The safety controller is a unit inside the control PC. It links safety-relevant signals and safety-relevant monitoring functions.

Safety controller tasks:

- Switching off the drives; applying the brakes
- Monitoring the braking ramp
- Standstill monitoring (after the stop)
- Velocity monitoring in T1
- Evaluation of safety-relevant signals
- Setting of safety-oriented outputs

3.5.3 Mode selection

The industrial robot can be operated in the following modes:

- Manual Reduced Velocity (T1)
- Manual High Velocity (T2)
- Automatic (AUT)
- Automatic External (AUT EXT)



Do not change the operating mode while a program is running. If the operating mode is changed during program execution, the industrial robot is stopped with a safety stop 2.

Operating mode	Use	Velocities
T1	For test operation, programming and teaching	<ul style="list-style-type: none"> ■ Program verification: Programmed velocity, maximum 250 mm/s ■ Manual mode: Jog velocity, maximum 250 mm/s
T2	For test operation	<ul style="list-style-type: none"> ■ Program verification: Programmed velocity ■ Manual mode: Not possible
AUT	For industrial robots without higher-level controllers	<ul style="list-style-type: none"> ■ Program mode: Programmed velocity ■ Manual mode: Not possible
AUT EXT	For industrial robots with higher-level controllers, e.g. PLC	<ul style="list-style-type: none"> ■ Program mode: Programmed velocity ■ Manual mode: Not possible

3.5.4 “Operator safety” signal

The “operator safety” signal is used for interlocking physical safeguards, e.g. safety gates. Automatic operation is not possible without this signal. In the

event of a loss of signal during automatic operation (e.g. safety gate is opened), the manipulator stops with a safety stop 1.

Operator safety is not active in modes T1 (Manual Reduced Velocity) and T2 (Manual High Velocity).

WARNING Following a loss of signal, automatic operation may only be resumed when the safeguard has been closed and when the closing has been acknowledged. This acknowledgement is to prevent automatic operation from being resumed inadvertently while there are still persons in the danger zone, e.g. due to the safety gate closing accidentally. The acknowledgement must be designed in such a way that an actual check of the danger zone can be carried out first. Other acknowledgement functions (e.g. an acknowledgement which is automatically triggered by closure of the safeguard) are not permitted. The system integrator is responsible for ensuring that these criteria are met. Failure to meet them may result in death, severe injuries or considerable damage to property.

3.5.5 EMERGENCY STOP device

The EMERGENCY STOP device for the industrial robot is the EMERGENCY STOP device on the smartPAD. The device must be pressed in the event of a hazardous situation or emergency.

Reactions of the industrial robot if the EMERGENCY STOP device is pressed:

- The manipulator and any external axes (optional) are stopped with a safety stop 1.

Before operation can be resumed, the EMERGENCY STOP device must be turned to release it.

WARNING Tools and other equipment connected to the manipulator must be integrated into the EMERGENCY STOP circuit on the system side if they could constitute a potential hazard. Failure to observe this precaution may result in death, severe injuries or considerable damage to property.

There must always be at least one external EMERGENCY STOP device installed. This ensures that an EMERGENCY STOP device is available even when the smartPAD is disconnected.

(>>> 3.5.7 "External EMERGENCY STOP device" Page 71)

3.5.6 Logging off from the higher-level safety controller

If the robot controller is connected to a higher-level safety controller, this connection will inevitably be terminated in the following cases:

- Switching off the voltage via the main switch of the robot
Or power failure
- Shutdown of the robot controller via the smartHMI
- Activation of a WorkVisual project in WorkVisual or directly on the robot controller
- Changes to **Start-up > Network configuration**
- Changes to **Configuration > Safety configuration**
- **I/O drivers > Reconfigure**
- Restoration of an archive

Effect of the interruption:

- If a discrete safety interface is used, this triggers an EMERGENCY STOP for the overall system.
- If the Ethernet interface is used, the KUKA safety controller generates a signal that prevents the higher-level controller from triggering an EMERGENCY STOP for the overall system.



If the Ethernet safety interface is used: In his risk assessment, the system integrator must take into consideration whether the fact that switching off the robot controller does not trigger an EMERGENCY STOP of the overall system could constitute a hazard and, if so, how this hazard can be countered.
Failure to take this into consideration may result in death, injuries or damage to property.



If a robot controller is switched off, the E-STOP device on the smartPAD is no longer functional. The user is responsible for ensuring that the smartPAD is either covered or removed from the system. This serves to prevent operational and non-operational EMERGENCY STOP devices from becoming interchanged.
Failure to observe this precaution may result in death, injuries or damage to property.

3.5.7 External EMERGENCY STOP device

Every operator station that can initiate a robot motion or other potentially hazardous situation must be equipped with an EMERGENCY STOP device. The system integrator is responsible for ensuring this.

There must always be at least one external EMERGENCY STOP device installed. This ensures that an EMERGENCY STOP device is available even when the smartPAD is disconnected.

External EMERGENCY STOP devices are connected via the customer interface. External EMERGENCY STOP devices are not included in the scope of supply of the industrial robot.

3.5.8 Enabling device

The enabling devices of the industrial robot are the enabling switches on the smartPAD.

There are 3 enabling switches installed on the smartPAD. The enabling switches have 3 positions:

- Not pressed
- Center position
- Panic position

In the test modes, the manipulator can only be moved if one of the enabling switches is held in the central position.

- Releasing the enabling switch triggers a safety stop 2.
- Pressing the enabling switch down fully (panic position) triggers a safety stop 1.
- It is possible to hold 2 enabling switches in the center position simultaneously for up to 15 seconds. This makes it possible to adjust grip from one enabling switch to another one. If 2 enabling switches are held simultaneously in the center position for longer than 15 seconds, this triggers a safety stop 1.

If an enabling switch malfunctions (jams), the industrial robot can be stopped using the following methods:

- Press the enabling switch down fully
- Actuate the EMERGENCY STOP system
- Release the Start key

**WARNING**

The enabling switches must not be held down by adhesive tape or other means or tampered with in any other way.
Death, injuries or damage to property may result.

3.5.9 External enabling device

External enabling devices are required if it is necessary for more than one person to be in the danger zone of the industrial robot.

External enabling devices are not included in the scope of supply of the industrial robot.



Which interface can be used for connecting external enabling devices is described in the "Planning" chapter of the robot controller operating instructions and assembly instructions.

3.5.10 External safe operational stop

The safe operational stop can be triggered via an input on the customer interface. The state is maintained as long as the external signal is FALSE. If the external signal is TRUE, the manipulator can be moved again. No acknowledgement is required.

3.5.11 External safety stop 1 and external safety stop 2

Safety stop 1 and safety stop 2 can be triggered via an input on the customer interface. The state is maintained as long as the external signal is FALSE. If the external signal is TRUE, the manipulator can be moved again. No acknowledgement is required.



No external safety stop 1 is available for the controller variant "KR C4 compact".

3.5.12 Velocity monitoring in T1

The velocity at the TCP is monitored in T1 mode. If the velocity exceeds 250 mm/s, a safety stop 0 is triggered.

3.6 Additional protective equipment

3.6.1 Jog mode

In the operating modes T1 (Manual Reduced Velocity) and T2 (Manual High Velocity), the robot controller can only execute programs in jog mode. This means that it is necessary to hold down an enabling switch and the Start key in order to execute a program.

- Releasing the enabling switch triggers a safety stop 2.

- Pressing the enabling switch down fully (panic position) triggers a safety stop 1.
- Releasing the Start key triggers a STOP 2.

3.6.2 Software limit switches

The axis ranges of all manipulator and positioner axes are limited by means of adjustable software limit switches. These software limit switches only serve as machine protection and must be adjusted in such a way that the manipulator/positioner cannot hit the mechanical end stops.

The software limit switches are set during commissioning of an industrial robot.



Further information is contained in the operating and programming instructions.

3.6.3 Mechanical end stops

Depending on the robot variant, the axis ranges of the main and wrist axes of the manipulator are partially limited by mechanical end stops.

Additional mechanical end stops can be installed on the external axes.



WARNING If the manipulator or an external axis hits an obstruction or a mechanical end stop or axis range limitation, the manipulator can no longer be operated safely. The manipulator must be taken out of operation and KUKA Roboter GmbH must be consulted before it is put back into operation (>>> 7 "KUKA Service" Page 125).

3.6.4 Mechanical axis range limitation (optional)

Some manipulators can be fitted with mechanical axis range limitation in axes A1 to A3. The adjustable axis range limitation systems restrict the working range to the required minimum. This increases personal safety and protection of the system.

In the case of manipulators that are not designed to be fitted with mechanical axis range limitation, the workspace must be laid out in such a way that there is no danger to persons or material property, even in the absence of mechanical axis range limitation.

If this is not possible, the workspace must be limited by means of photoelectric barriers, photoelectric curtains or obstacles on the system side. There must be no shearing or crushing hazards at the loading and transfer areas.



This option is not available for all robot models. Information on specific robot models can be obtained from KUKA Roboter GmbH.

3.6.5 Axis range monitoring (optional)

Some manipulators can be fitted with dual-channel axis range monitoring systems in main axes A1 to A3. The positioner axes may be fitted with additional axis range monitoring systems. The safety zone for an axis can be adjusted and monitored using an axis range monitoring system. This increases personal safety and protection of the system.



This option is not available for all robot models. Information on specific robot models can be obtained from KUKA Roboter GmbH.

3.6.6 Options for moving the manipulator without drive energy



The system user is responsible for ensuring that the training of personnel with regard to the response to emergencies or exceptional situations also includes how the manipulator can be moved without drive energy.

Description

The following options are available for moving the manipulator without drive energy after an accident or malfunction:

- Release device (optional)
The release device can be used for the main axis drive motors and, depending on the robot variant, also for the wrist axis drive motors.
- Brake release device (option)
The brake release device is designed for robot variants whose motors are not freely accessible.
- Moving the wrist axes directly by hand
There is no release device available for the wrist axes of variants in the low payload category. This is not necessary because the wrist axes can be moved directly by hand.



Information about the options available for the various robot models and about how to use them can be found in the assembly and operating instructions for the robot or requested from KUKA Roboter GmbH.

NOTICE

Moving the manipulator without drive energy can damage the motor brakes of the axes concerned. The motor must be replaced if the brake has been damaged. The manipulator may therefore be moved without drive energy only in emergencies, e.g. for rescuing persons.

3.6.7 Labeling on the industrial robot

All plates, labels, symbols and marks constitute safety-relevant parts of the industrial robot. They must not be modified or removed.

Labeling on the industrial robot consists of:

- Identification plates
- Warning signs
- Safety symbols
- Designation labels
- Cable markings
- Rating plates



Further information is contained in the technical data of the operating instructions or assembly instructions of the components of the industrial robot.

3.6.8 External safeguards

The access of persons to the danger zone of the industrial robot must be prevented by means of safeguards. It is the responsibility of the system integrator to ensure this.

Physical safeguards must meet the following requirements:

- They meet the requirements of EN 953.
- They prevent access of persons to the danger zone and cannot be easily circumvented.
- They are sufficiently fastened and can withstand all forces that are likely to occur in the course of operation, whether from inside or outside the enclosure.
- They do not, themselves, represent a hazard or potential hazard.
- The prescribed minimum clearance from the danger zone is maintained.

Safety gates (maintenance gates) must meet the following requirements:

- They are reduced to an absolute minimum.
- The interlocks (e.g. safety gate switches) are linked to the operator safety input of the robot controller via safety gate switching devices or safety PLC.
- Switching devices, switches and the type of switching conform to the requirements of Performance Level d and category 3 according to EN ISO 13849-1.
- Depending on the risk situation: the safety gate is additionally safeguarded by means of a locking mechanism that only allows the gate to be opened if the manipulator is safely at a standstill.
- The button for acknowledging the safety gate is located outside the space limited by the safeguards.

 Further information is contained in the corresponding standards and regulations. These also include EN 953.

Other safety equipment

Other safety equipment must be integrated into the system in accordance with the corresponding standards and regulations.

3.7 Overview of operating modes and safety functions

The following table indicates the operating modes in which the safety functions are active.

Safety functions	T1	T2	AUT	AUT EXT
Operator safety	-	-	active	active
EMERGENCY STOP device	active	active	active	active
Enabling device	active	active	-	-
Reduced velocity during program verification	active	-	-	-
Jog mode	active	active	-	-
Software limit switches	active	active	active	active

3.8 Safety measures

3.8.1 General safety measures

The industrial robot may only be used in perfect technical condition in accordance with its intended use and only by safety-conscious persons. Operator errors can result in personal injury and damage to property.

It is important to be prepared for possible movements of the industrial robot even after the robot controller has been switched off and locked out. Incorrect installation (e.g. overload) or mechanical defects (e.g. brake defect) can cause the manipulator or external axes to sag. If work is to be carried out on a switched-off industrial robot, the manipulator and external axes must first be moved into a position in which they are unable to move on their own, whether the payload is mounted or not. If this is not possible, the manipulator and external axes must be secured by appropriate means.

 **DANGER** In the absence of operational safety functions and safeguards, the industrial robot can cause personal injury or material damage. If safety functions or safeguards are dismantled or deactivated, the industrial robot may not be operated.

 **DANGER** Standing underneath the robot arm can cause death or injuries. For this reason, standing underneath the robot arm is prohibited!

 **CAUTION** The motors reach temperatures during operation which can cause burns to the skin. Contact must be avoided. Appropriate safety precautions must be taken, e.g. protective gloves must be worn.

smartPAD

The user must ensure that the industrial robot is only operated with the smartPAD by authorized persons.

If more than one smartPAD is used in the overall system, it must be ensured that each smartPAD is unambiguously assigned to the corresponding industrial robot. They must not be interchanged.

 **WARNING** The operator must ensure that decoupled smartPADs are immediately removed from the system and stored out of sight and reach of personnel working on the industrial robot. This serves to prevent operational and non-operational EMERGENCY STOP devices from becoming interchanged. Failure to observe this precaution may result in death, severe injuries or considerable damage to property.

Modifications

After modifications to the industrial robot, checks must be carried out to ensure the required safety level. The valid national or regional work safety regulations must be observed for this check. The correct functioning of all safety functions must also be tested.

New or modified programs must always be tested first in Manual Reduced Velocity mode (T1).

After modifications to the industrial robot, existing programs must always be tested first in Manual Reduced Velocity mode (T1). This applies to all components of the industrial robot and includes modifications to the software and configuration settings.

Faults

The following tasks must be carried out in the case of faults in the industrial robot:

- Switch off the robot controller and secure it (e.g. with a padlock) to prevent unauthorized persons from switching it on again.
- Indicate the fault by means of a label with a corresponding warning (tag-out).
- Keep a record of the faults.
- Eliminate the fault and carry out a function test.

3.8.2 Transportation

Manipulator The prescribed transport position of the manipulator must be observed. Transportation must be carried out in accordance with the operating instructions or assembly instructions of the robot.

Avoid vibrations and impacts during transportation in order to prevent damage to the manipulator.

Robot controller The prescribed transport position of the robot controller must be observed. Transportation must be carried out in accordance with the operating instructions or assembly instructions of the robot controller.

Avoid vibrations and impacts during transportation in order to prevent damage to the robot controller.

External axis (optional) The prescribed transport position of the external axis (e.g. KUKA linear unit, turn-tilt table, positioner) must be observed. Transportation must be carried out in accordance with the operating instructions or assembly instructions of the external axis.

3.8.3 Start-up and recommissioning

Before starting up systems and devices for the first time, a check must be carried out to ensure that the systems and devices are complete and operational, that they can be operated safely and that any damage is detected.

The valid national or regional work safety regulations must be observed for this check. The correct functioning of all safety functions must also be tested.



The passwords for the user groups must be changed in the KUKA System Software before start-up. The passwords must only be communicated to authorized personnel.



The robot controller is preconfigured for the specific industrial robot. If cables are interchanged, the manipulator and the external axes (optional) may receive incorrect data and can thus cause personal injury or material damage. If a system consists of more than one manipulator, always connect the connecting cables to the manipulators and their corresponding robot controllers.



If additional components (e.g. cables), which are not part of the scope of supply of KUKA Roboter GmbH, are integrated into the industrial robot, the user is responsible for ensuring that these components do not adversely affect or disable safety functions.

NOTICE

If the internal cabinet temperature of the robot controller differs greatly from the ambient temperature, condensation can form, which may cause damage to the electrical components. Do not put the robot controller into operation until the internal temperature of the cabinet has adjusted to the ambient temperature.

Function test

The following tests must be carried out before start-up and recommissioning:

General test:

It must be ensured that:

- The industrial robot is correctly installed and fastened in accordance with the specifications in the documentation.
- There are no foreign bodies or loose parts on the industrial robot.
- All required safety equipment is correctly installed and operational.
- The power supply ratings of the industrial robot correspond to the local supply voltage and mains type.
- The ground conductor and the equipotential bonding cable are sufficiently rated and correctly connected.
- The connecting cables are correctly connected and the connectors are locked.

Test of the safety functions:

A function test must be carried out for the following safety functions to ensure that they are functioning correctly:

- Local EMERGENCY STOP device
- External EMERGENCY STOP device (input and output)
- Enabling device (in the test modes)
- Operator safety
- All other safety-relevant inputs and outputs used
- Other external safety functions

3.8.3.1 Checking machine data and safety configuration

WARNING The industrial robot must not be moved if incorrect machine data or an incorrect controller configuration are loaded. Death, severe injuries or considerable damage to property may otherwise result. The correct data must be loaded.

- It must be ensured that the rating plate on the robot controller has the same machine data as those entered in the declaration of incorporation. The machine data on the rating plate of the manipulator and the external axes (optional) must be entered during start-up.
- The practical tests for the machine data must be carried out within the scope of the start-up procedure.
- Following modifications to the machine data, the safety configuration must be checked.
- After activation of a WorkVisual project on the robot controller, the safety configuration must be checked!
- If machine data are adopted when checking the safety configuration (regardless of the reason for the safety configuration check), the practical tests for the machine data must be carried out.
- System Software 8.3 or higher: If the checksum of the safety configuration has changed, the safe axis monitoring functions must be checked.



Information about checking the safety configuration and the safe axis monitoring functions is contained in the Operating and Programming Instructions for System Integrators.

If the practical tests are not successfully completed in the initial start-up, KUKA Roboter GmbH must be contacted.

If the practical tests are not successfully completed during a different procedure, the machine data and the safety-relevant controller configuration must be checked and corrected.

General practical test

If practical tests are required for the machine data, this test must always be carried out.

The following methods are available for performing the practical test:

- TCP calibration with the XYZ 4-point method

The practical test is passed if the TCP has been successfully calibrated.

Or:

1. Align the TCP with a freely selected point.
The point serves as a reference point. It must be located so that reorientation is possible.
2. Move the TCP manually at least 45° once in each of the A, B and C directions.

The movements do not have to be accumulative, i.e. after motion in one direction it is possible to return to the original position before moving in the next direction.

The practical test is passed if the TCP does not deviate from the reference point by more than 2 cm in total.

Practical test for axes that are not mathematically coupled

If practical tests are required for the machine data, this test must be carried out when axes are present that are not mathematically coupled.

1. Mark the starting position of the axis that is not mathematically coupled.
2. Move the axis manually by a freely selected path length. Determine the path length from the display **Actual position** on the smartHMI.
 - Move linear axes a specific distance.
 - Move rotational axes through a specific angle.
3. Measure the length of the path covered and compare it with the value displayed on the smartHMI.

The practical test is passed if the values differ by no more than 10%.

4. Repeat the test for each axis that is not mathematically coupled.

Practical test for couplable axes

If practical tests are required for the machine data, this test must be carried out when axes are present that can be physically coupled and uncoupled, e.g. a servo gun.

1. Physically uncouple the couplable axis.
2. Move all the remaining axes individually.

The practical test is passed if it has been possible to move all the remaining axes.

3.8.3.2 Start-up mode

Description

The industrial robot can be set to Start-up mode via the smartHMI user interface. In this mode, the manipulator can be moved in T1 without the external safeguards being put into operation.

When Start-up mode is possible depends on the safety interface that is used.

If a discrete safety interface is used:

- System Software 8.2 or earlier:

Start-up mode is always possible if all input signals at the discrete safety interface have the state "logic zero". If this is not the case, the robot controller prevents or terminates Start-up mode.

If an additional discrete safety interface for safety options is used, the inputs there must also have the state "logic zero".

- System Software 8.3:

Start-up mode is always possible. This also means that it is independent of the state of the inputs at the discrete safety interface.

If an additional discrete safety interface for safety options is used: the states of these inputs are not relevant either.

If the Ethernet safety interface is used:

The robot controller prevents or terminates Start-up mode if a connection to a higher-level safety system exists or is established.

Hazards

Possible hazards and risks involved in using Start-up mode:

- A person walks into the manipulator's danger zone.
- In a hazardous situation, a disabled external EMERGENCY STOP device is actuated and the manipulator is not shut down.

Additional measures for avoiding risks in Start-up mode:

- Cover disabled EMERGENCY STOP devices or attach a warning sign indicating that the EMERGENCY STOP device is out of operation.
- If there is no safety fence, other measures must be taken to prevent persons from entering the manipulator's danger zone, e.g. use of warning tape.

Use

Intended use of Start-up mode:

- Start-up in T1 mode when the external safeguards have not yet been installed or put into operation. The danger zone must be delimited at least by means of warning tape.
- Fault localization (periphery fault).
- Use of Start-up mode must be minimized as much as possible.



WARNING

Use of Start-up mode disables all external safeguards. The service personnel are responsible for ensuring that there is no-one in or near the danger zone of the manipulator as long as the safeguards are disabled. Failure to observe this precaution may result in death, injuries or damage to property.

Misuse

Any use or application deviating from the intended use is deemed to be misuse and is not allowed. KUKA Roboter GmbH is not liable for any damage resulting from such misuse. The risk lies entirely with the user.

3.8.4 Manual mode

Manual mode is the mode for setup work. Setup work is all the tasks that have to be carried out on the industrial robot to enable automatic operation. Setup work includes:

- Jog mode
- Teaching
- Programming
- Program verification

The following must be taken into consideration in manual mode:

- New or modified programs must always be tested first in Manual Reduced Velocity mode (T1).
- The manipulator, tooling or external axes (optional) must never touch or project beyond the safety fence.
- Workpieces, tooling and other objects must not become jammed as a result of the industrial robot motion, nor must they lead to short-circuits or be liable to fall off.
- All setup work must be carried out, where possible, from outside the safeguarded area.

If the setup work has to be carried out inside the safeguarded area, the following must be taken into consideration:

In **Manual Reduced Velocity mode (T1)**:

- If it can be avoided, there must be no other persons inside the safeguarded area.

If it is necessary for there to be several persons inside the safeguarded area, the following must be observed:

- Each person must have an enabling device.
- All persons must have an unimpeded view of the industrial robot.
- Eye-contact between all persons must be possible at all times.
- The operator must be so positioned that he can see into the danger area and get out of harm's way.

In **Manual High Velocity mode (T2)**:

- This mode may only be used if the application requires a test at a velocity higher than Manual Reduced Velocity.
- Teaching and programming are not permissible in this operating mode.
- Before commencing the test, the operator must ensure that the enabling devices are operational.
- The operator must be positioned outside the danger zone.
- There must be no other persons inside the safeguarded area. It is the responsibility of the operator to ensure this.

3.8.5 Simulation

Simulation programs do not correspond exactly to reality. Robot programs created in simulation programs must be tested in the system in **Manual Reduced Velocity mode (T1)**. It may be necessary to modify the program.

3.8.6 Automatic mode

Automatic mode is only permissible in compliance with the following safety measures:

- All safety equipment and safeguards are present and operational.
- There are no persons in the system.
- The defined working procedures are adhered to.

If the manipulator or an external axis (optional) comes to a standstill for no apparent reason, the danger zone must not be entered until an EMERGENCY STOP has been triggered.

3.8.7 Maintenance and repair

After maintenance and repair work, checks must be carried out to ensure the required safety level. The valid national or regional work safety regulations must be observed for this check. The correct functioning of all safety functions must also be tested.

The purpose of maintenance and repair work is to ensure that the system is kept operational or, in the event of a fault, to return the system to an operational state. Repair work includes troubleshooting in addition to the actual repair itself.

The following safety measures must be carried out when working on the industrial robot:

- Carry out work outside the danger zone. If work inside the danger zone is necessary, the user must define additional safety measures to ensure the safe protection of personnel.
- Switch off the industrial robot and secure it (e.g. with a padlock) to prevent it from being switched on again. If it is necessary to carry out work with the robot controller switched on, the user must define additional safety measures to ensure the safe protection of personnel.
- If it is necessary to carry out work with the robot controller switched on, this may only be done in operating mode T1.
- Label the system with a sign indicating that work is in progress. This sign must remain in place, even during temporary interruptions to the work.
- The EMERGENCY STOP systems must remain active. If safety functions or safeguards are deactivated during maintenance or repair work, they must be reactivated immediately after the work is completed.

 **DANGER** Before work is commenced on live parts of the robot system, the main switch must be turned off and secured against being switched on again. The system must then be checked to ensure that it is deenergized. It is not sufficient, before commencing work on live parts, to execute an EMERGENCY STOP or a safety stop, or to switch off the drives, as this does not disconnect the robot system from the mains power supply. Parts remain energized. Death or severe injuries may result.

Faulty components must be replaced using new components with the same article numbers or equivalent components approved by KUKA Roboter GmbH for this purpose.

Cleaning and preventive maintenance work is to be carried out in accordance with the operating instructions.

Robot controller

Even when the robot controller is switched off, parts connected to peripheral devices may still carry voltage. The external power sources must therefore be switched off if work is to be carried out on the robot controller.

The ESD regulations must be adhered to when working on components in the robot controller.

Voltages in excess of 50 V (up to 780 V) can be present in various components for several minutes after the robot controller has been switched off! To prevent life-threatening injuries, no work may be carried out on the industrial robot in this time.

Water and dust must be prevented from entering the robot controller.

Counterbalancing system

Some robot variants are equipped with a hydropneumatic, spring or gas cylinder counterbalancing system.

The hydropneumatic and gas cylinder counterbalancing systems are pressure equipment and, as such, are subject to obligatory equipment monitoring and the provisions of the Pressure Equipment Directive.

The user must comply with the applicable national laws, regulations and standards pertaining to pressure equipment.

Inspection intervals in Germany in accordance with Industrial Safety Order, Sections 14 and 15. Inspection by the user before commissioning at the installation site.

The following safety measures must be carried out when working on the counterbalancing system:

- The manipulator assemblies supported by the counterbalancing systems must be secured.
- Work on the counterbalancing systems must only be carried out by qualified personnel.

Hazardous substances

The following safety measures must be carried out when handling hazardous substances:

- Avoid prolonged and repeated intensive contact with the skin.
- Avoid breathing in oil spray or vapors.
- Clean skin and apply skin cream.



To ensure safe use of our products, we recommend that our customers regularly request up-to-date safety data sheets from the manufacturers of hazardous substances.

3.8.8 Decommissioning, storage and disposal

The industrial robot must be decommissioned, stored and disposed of in accordance with the applicable national laws, regulations and standards.

3.8.9 Safety measures for “single point of control”

Overview

If certain components in the industrial robot are operated, safety measures must be taken to ensure complete implementation of the principle of “single point of control” (SPOC).

The relevant components are:

- Submit interpreter
- PLC
- OPC server
- Remote control tools
- Tools for configuration of bus systems with online functionality
- KUKA.RobotSensorInterface



The implementation of additional safety measures may be required. This must be clarified for each specific application; this is the responsibility of the system integrator, programmer or user of the system.

Since only the system integrator knows the safe states of actuators in the periphery of the robot controller, it is his task to set these actuators to a safe state, e.g. in the event of an EMERGENCY STOP.

T1, T2

In modes T1 and T2, the components referred to above may only access the industrial robot if the following signals have the following states:

Signal	State required for SPOC
\$USER_SAF	TRUE
\$SPOC_MOTION_ENABLE	TRUE

Submit interpreter, PLC

If motions, (e.g. drives or grippers) are controlled with the submit interpreter or the PLC via the I/O system, and if they are not safeguarded by other means, then this control will take effect even in T1 and T2 modes or while an EMERGENCY STOP is active.

If variables that affect the robot motion (e.g. override) are modified with the submit interpreter or the PLC, this takes effect even in T1 and T2 modes or while an EMERGENCY STOP is active.

Safety measures:

- In T1 and T2, the system variable \$OV_PRO must not be written to by the submit interpreter or the PLC.
- Do not modify safety-relevant signals and variables (e.g. operating mode, EMERGENCY STOP, safety gate contact) via the submit interpreter or PLC.

If modifications are nonetheless required, all safety-relevant signals and variables must be linked in such a way that they cannot be set to a dangerous state by the submit interpreter or PLC. This is the responsibility of the system integrator.

OPC server, remote control tools

These components can be used with write access to modify programs, outputs or other parameters of the robot controller, without this being noticed by any persons located inside the system.

Safety measure:

If these components are used, outputs that could cause a hazard must be determined in a risk assessment. These outputs must be designed in such a way that they cannot be set without being enabled. This can be done using an external enabling device, for example.

Tools for configuration of bus systems

If these components have an online functionality, they can be used with write access to modify programs, outputs or other parameters of the robot controller, without this being noticed by any persons located inside the system.

- WorkVisual from KUKA
- Tools from other manufacturers

Safety measure:

In the test modes, programs, outputs or other parameters of the robot controller must not be modified using these components.

3.9 Applied norms and regulations

Name	Definition	Edition
2006/42/EC	Machinery Directive: Directive 2006/42/EC of the European Parliament and of the Council of 17 May 2006 on machinery, and amending Directive 95/16/EC (recast)	2006

2004/108/EC	EMC Directive: Directive 2004/108/EC of the European Parliament and of the Council of 15 December 2004 on the approximation of the laws of the Member States relating to electromagnetic compatibility and repealing Directive 89/336/EEC	2004
97/23/EC	Pressure Equipment Directive: Directive 97/23/EC of the European Parliament and of the Council of 29 May 1997 on the approximation of the laws of the Member States concerning pressure equipment (Only applicable for robots with hydropneumatic counterbalancing system.)	1997
EN ISO 13850	Safety of machinery: Emergency stop - Principles for design	2008
EN ISO 13849-1	Safety of machinery: Safety-related parts of control systems - Part 1: General principles of design	2008
EN ISO 13849-2	Safety of machinery: Safety-related parts of control systems - Part 2: Validation	2012
EN ISO 12100	Safety of machinery: General principles of design, risk assessment and risk reduction	2010
EN ISO 10218-1	Industrial robots: Safety Note: Content equivalent to ANSI/RIA R.15.06-2012, Part 1	2011
EN 614-1	Safety of machinery: Ergonomic design principles - Part 1: Terms and general principles	2009
EN 61000-6-2	Electromagnetic compatibility (EMC): Part 6-2: Generic standards; Immunity for industrial environments	2005
EN 61000-6-4 + A1	Electromagnetic compatibility (EMC): Part 6-4: Generic standards; Emission standard for industrial environments	2011
EN 60204-1 + A1	Safety of machinery: Electrical equipment of machines - Part 1: General requirements	2009

4 Planning

4.1 Electromagnetic compatibility (EMC)

Description

If connecting cables (e.g. field buses, etc.) are routed to the control PC from outside, only shielded cables with an adequate degree of shielding may be used. The cable shield must be connected with maximum surface area to the PE rail in the cabinet using shield terminals (screw-type, no clamps).



The robot controller corresponds to EMC class A, Group 1, in accordance with EN 55011 and is intended for use in an **industrial setting**. Ascertaining the electromagnetic compatibility in other environments can result in difficulties due to conducted and radiated disturbance that may occur.

4.2 Installation conditions

The dimensions of the robot controller are indicated in the diagram (>>> Fig. 4-1).

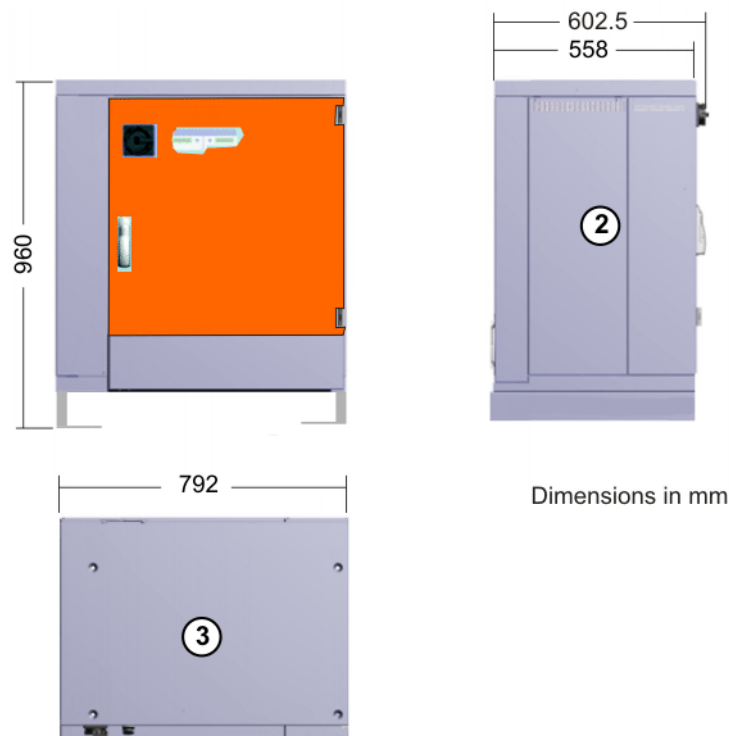

Fig. 4-1: Dimensions

- 1 Front view
- 2 Side view
- 3 Top view

The minimum clearances that must be maintained for the robot controller are indicated in the diagram (>>> Fig. 4-2).

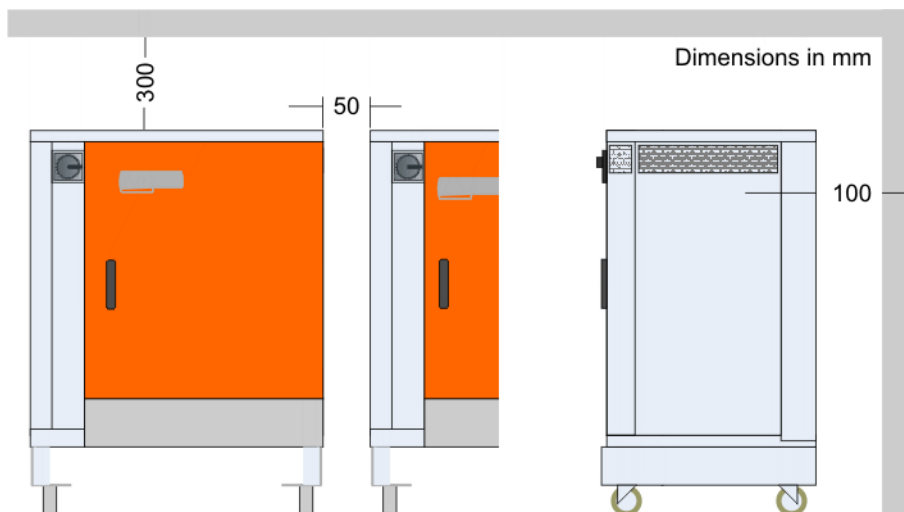

Fig. 4-2: Minimum clearances

NOTICE If the minimum clearances are not maintained, this can result in damage to the robot controller. The specified minimum clearances must always be observed.

i Certain maintenance and repair tasks on the robot controller must be carried out from the side or from the rear. The robot controller must be accessible for this. If the side or rear panels are not accessible, it must be possible to move the robot controller into a position in which the work can be carried out.

The diagram (>>> Fig. 4-3) shows the swing range for the door.

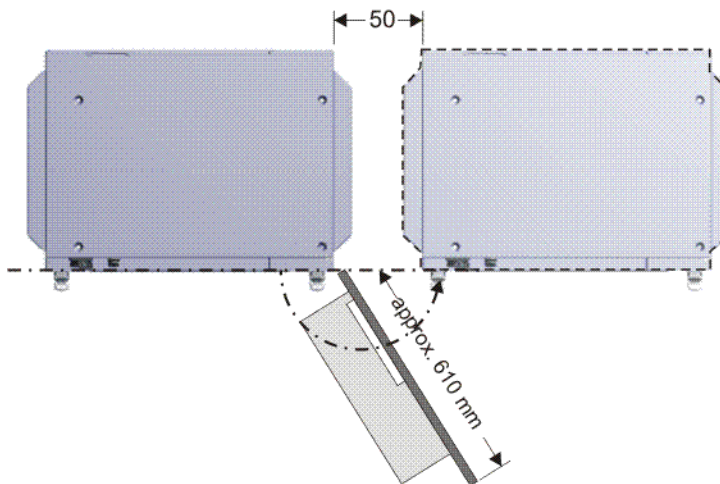

Fig. 4-3: Swing range for cabinet door

Swing range, standalone cabinet:

- Door with computer frame approx. 180°

Swing range, butt-mounted cabinets:

- Door approx. 155°

4.3 Connection conditions

Power supply connection

CAUTION If the robot controller is connected to a power system without a grounded neutral or is operated with incorrect machine data, this may cause malfunctions in the robot controller and material damage to the power supply units. Electrical voltage can cause injuries. The robot controller may only be operated with grounded-neutral power supply systems.

If no grounded neutral is available, or if the mains voltage differs from those specified here, a transformer must be used.

Rated supply voltage according to the machine data, optionally:	AC 3x380 V, AC 3x400 V, AC 3x440 V or AC 3x480 V
Permissible tolerance of rated supply voltage	Rated supply voltage $\pm 10\%$
Mains frequency	49 ... 61 Hz
System impedance up to the connection point of the robot controller	$\leq 300 \text{ m}\Omega$
Full-load current	See identification plate
Mains-side fusing without transformer	min. 3x25 A, slow-blowing
Mains-side fusing with transformer	min. 3x32 A, slow-blowing, with 13 kVA
Equipotential bonding	The common neutral point for the equipotential bonding conductors and all protective ground conductors is the reference bus of the power unit.

CAUTION If the robot controller is connected to a power system **without** a grounded neutral, this may cause malfunctions in the robot controller and material damage to the power supply units. Electrical voltage can cause injuries. The robot controller may only be operated with grounded-neutral power supply systems.

NOTICE If the robot controller is operated with a supply voltage other than that specified on the rating plate, this may cause malfunctions in the robot controller and material damage to the power supply units. The robot controller may only be operated with the supply voltage specified on the rating plate.

i The appropriate machine data must be loaded in accordance with the rated supply voltage.

i If use of a residual-current circuit-breaker (RCCB) is planned, we recommend the following RCCB: trip current difference 300 mA per robot controller, universal-current sensitive, selective.

Cable lengths

For cable designations, standard lengths and optional lengths, please refer to the operating instructions or assembly instructions of the manipulator and/or the assembly and operating instructions for KR C4 external cabling for robot controllers.

! When using smartPAD cable extensions, only two extensions may be used. An overall cable length of 50 m must not be exceeded.

 The difference in the cable lengths between the individual channels of the RDC box must not exceed 10 m.

PELV external power supply

External voltage	PELV power supply unit acc. to EN 60950 with rated voltage 27 V (18 V ... 30 V), safely isolated
Continuous current	> 8 A
Cable cross-section of power supply cable	≥ 1 mm ²
Cable length of power supply cable	< 50 m, or < 100 m wire length (outgoing and incoming lines)

 The cables of the power supply unit must not be routed together with power-carrying cables.

 The minus connection of the external voltage must be grounded by the customer.

 Parallel connection of a basic-insulated device is not permitted.

4.4 Fastening the KUKA smartPAD holder (optional)

Overview

The smartPAD holder can be installed on the door of the robot controller or on the safety fence.

The following diagram (>>> Fig. 4-4) shows the options for fastening the smartPAD holder.

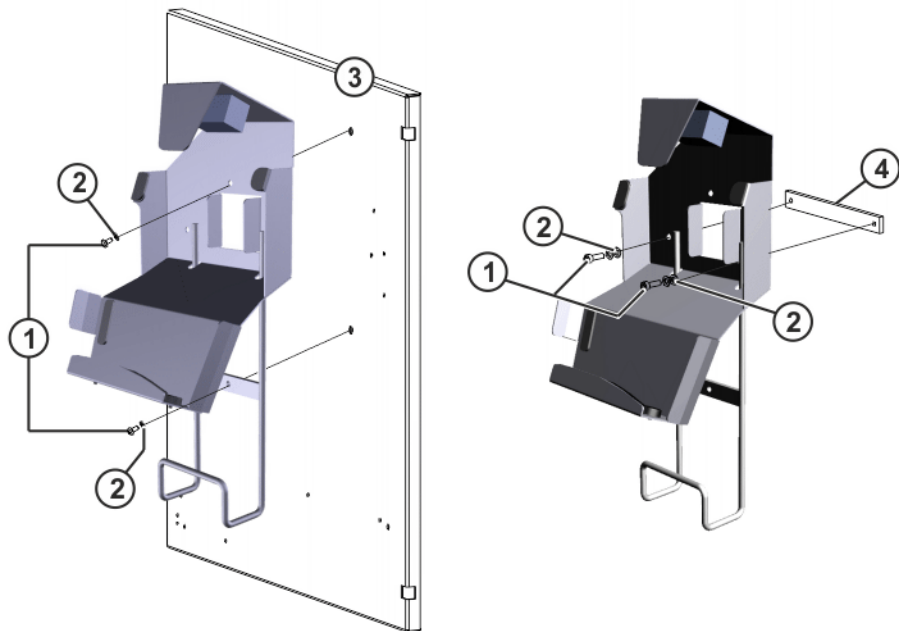

Fig. 4-4: smartPAD holder

- 1 M6x12 Allen screw
- 2 Spring lock washer A6.1 and plain washer
- 3 Door of robot controller
- 4 Iron flat for fence mounting

4.5 Power supply connection on the main switch

Description Power infeed is via a cable gland located on the top of the control cabinet on the left-hand side. The power supply connection cable is routed and connected to the main switch.



Fig. 4-5: Power supply connection at main switch

- 1 Cable inlet
- 2 PE connection
- 3 Power supply connection at main switch

4.6 Description of safety interface X11

Description EMERGENCY STOP devices must be connected via safety interface X11 or linked together by means of higher-level controllers (e.g. PLC). (>>> "SIB outputs" Page 55)

Wiring Take the following points into consideration when wiring safety interface X11:

- System concept
- Safety concept

4.6.1 Interface X11

Connector pin allocation

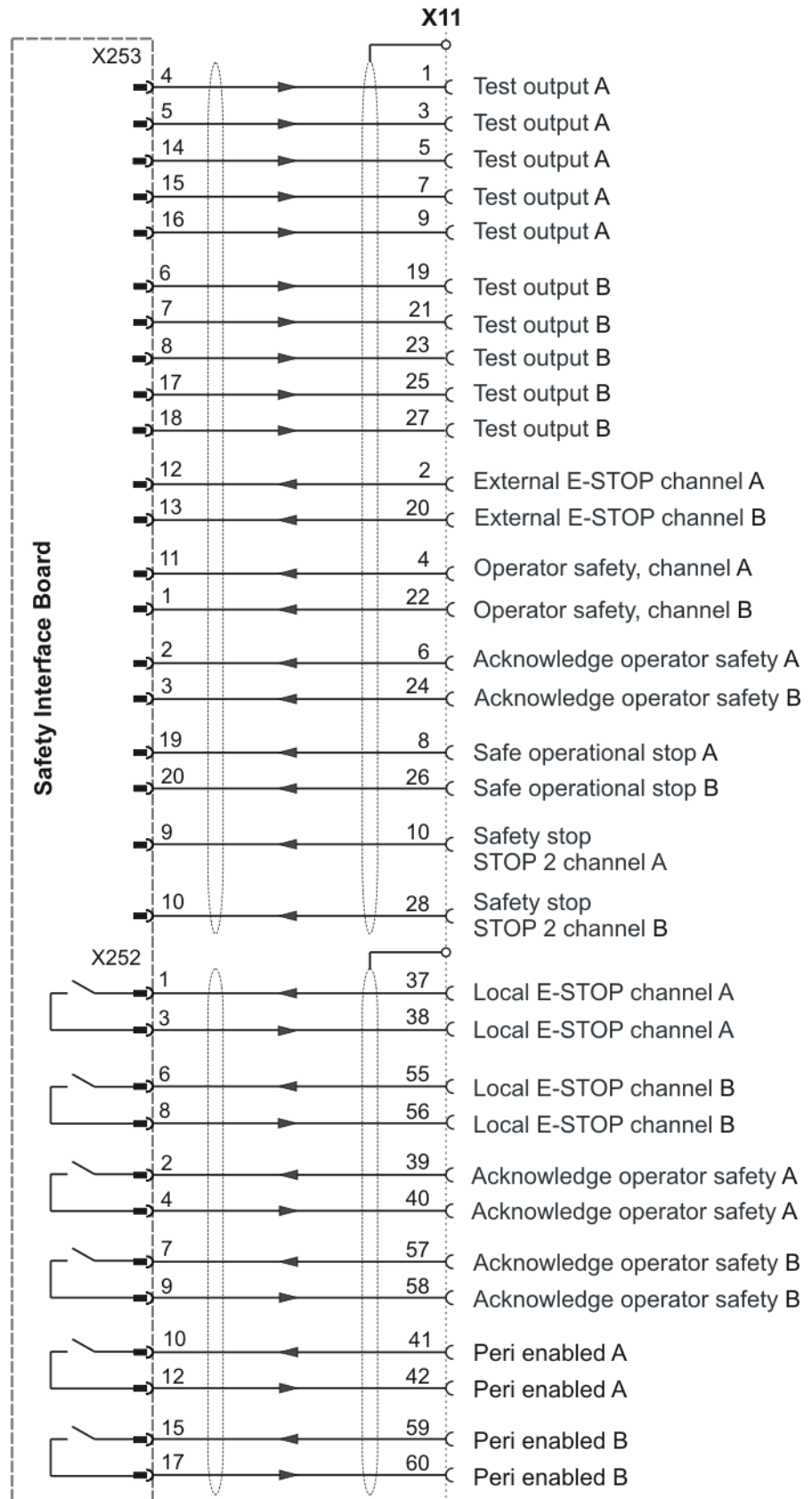

Fig. 4-6: Interface X11, connector pin allocation

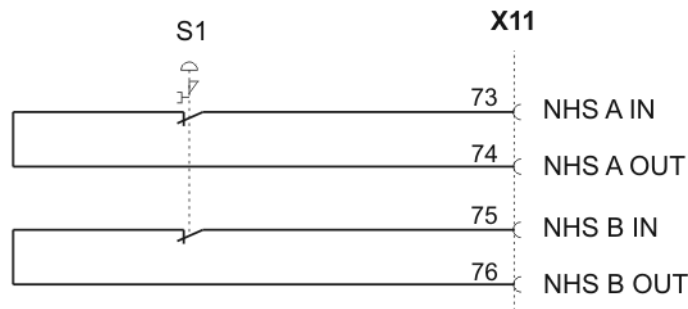

Fig. 4-7: X11 interface, EMERGENCY STOP device pin allocation (optional)

Signal	Pin	Description	Comments
Test output A (test signal)	1	Makes the pulsed voltage available for the individual interface inputs of channel A.	-
	3		
	5		
	7		
	9		
	11		
Test output B (test signal)	13	Makes the clocked voltage available for the individual interface inputs of channel B.	-
	19		
	21		
	23		
	25		
	27		
Safe operational stop, channel A	8	Safe operational stop input for all axes	Activation of standstill monitoring Stop 0 is initiated if the activated monitoring is violated.
Safe operational stop, channel B	26		
Safety stop, Stop 2 channel A	10	Safety stop (Stop 2) input for all axes	Triggering of Stop 2 and activation of standstill monitoring at standstill of all axes. Stop 0 is initiated if the activated monitoring is violated.
Safety stop, Stop 2 channel B	28		
Local E-STOP channel A	37	Output, floating contacts from internal E-STOP, (>>> "SIB outputs" Page 55)	The contacts are closed if the following conditions are met: <ul style="list-style-type: none"> ■ E-STOP on smartPAD not actuated ■ Controller switched on and operational The contacts open if any condition is not met.
Local E-STOP channel B	38		
Local E-STOP channel B	55		
Local E-STOP channel B	56		
External E-STOP channel A	2	Dual-channel E-STOP input, (>>> "SIB inputs" Page 56)	Triggering of the E-STOP function in the robot controller.
External E-STOP channel B	20		

Signal	Pin	Description	Comments
Acknowledge operator safety, channel A	6	For connection of a dual-channel input for acknowledging operator safety with floating contacts, (>>> "SIB inputs" Page 56)	The response of the "Operator safety acknowledgement" input can be configured in the KUKA system software. After closing the safety gate (operator safety), manipulator motion can be enabled in the automatic modes using an acknowledge button outside the safety fence. This function is deactivated on delivery.
Acknowledge operator safety, channel B	24		
Operator safety, channel A	4	For 2-channel connection of a safety gate locking mechanism, (>>> "SIB inputs" Page 56)	As long as the signal is active, the drives can be switched on. Only effective in the AUTOMATIC modes.
Operator safety, channel B	22		
Peri enabled channel A	41	Output, floating contacts (>>> "SIB outputs" Page 55)	(>>> "Signal "Peri enabled" (PE)" Page 94)
	42		
Peri enabled channel B	59	Output, floating contacts (>>> "SIB outputs" Page 55)	
	60		
Acknowledge operator safety, channel A	39	Output, floating contact for operator safety acknowledgement, connection 1 (>>> "SIB outputs" Page 55)	Relaying of the acknowledge operator safety input signal to other robot controllers at the same safety fencing.
	40		
Acknowledge operator safety, channel B	57	Output, floating contact for operator safety acknowledgement, connection 1 (>>> "SIB outputs" Page 55)	
	58		
NHS channel A	73	Output, floating EMERGENCY STOP contact, channel A	For connection, see (>>> 4.6.3 "EMERGENCY STOP device on the robot controller (optional)" Page 96)
	74		
NHS channel B	75	Output, floating EMERGENCY STOP contact, channel B	
	76		

Signal "Peri enabled" (PE)

The signal "Peri enabled" is set to 1 (active) if the following conditions are met:

- Drives are switched on.
- Safety controller motion enable signal present.
- The message "Operator safety open" must not be active.
This message is only active in the modes T1 and T2.

"Peri enabled" in conjunction with the signal "Safe operational stop"

- In the case of activation of the signal "Safe operational stop" during the motion:
 - Error -> braking with Stop 0. "Peri enabled" eliminated.

- Activation of the signal “Safe operational stop” with the manipulator stationary:
Release the brakes, switch drives to servo-control and monitor for restart. “Peri enabled” remains active.

- Signal “Motion enable” remains active.
- US2 voltage (if present) remains active.
- Signal “Peri enabled” remains active.

“Peri enabled” in conjunction with the signal “Safety stop 2”

- In the case of activation of the signal “Safety stop 2”:
 - Stop 2 of the manipulator.
 - Signal “Drive enable” remains active.
 - Brakes remain released.
 - Manipulator remains under servo-control.
 - Monitoring for restart active.
 - Signal “Motion enable” is deactivated.
 - US2 voltage (if present) is deactivated.
 - Signal “Peri enabled” is deactivated.



In the cabling for the input signals and test signals in the system, suitable measures must be taken to prevent a cross-connection between the voltages (e.g. separate cabling of input signals and test signals).



In the cabling for the output signals and test signals in the system, suitable measures must be taken to prevent a cross-connection between the output signals of a channel (e.g. separate cabling).

4.6.2 Interface X11 – external enabling switch

Connector pin allocation

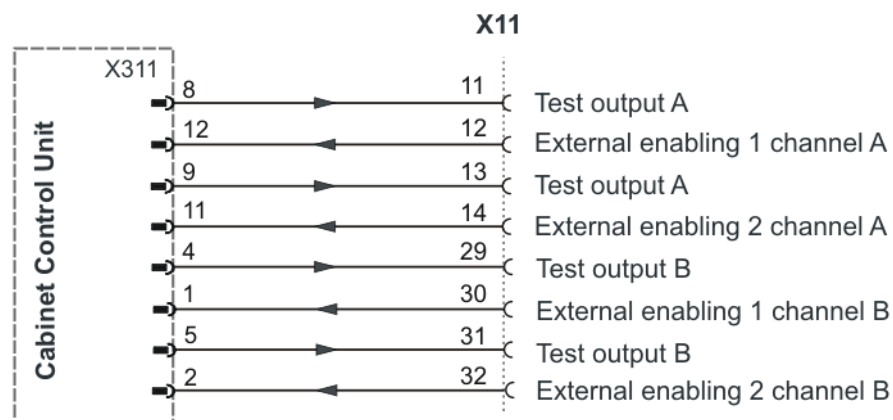

Fig. 4-8: Interface X11, connector pin allocation for external enabling switch

Signal	Pin	Description	Comments
CCU test output A (test signal)	11 13	Makes the pulsed voltage available for the individual interface inputs of channel A.	These signals may only be mapped with the CCU.
CCU test output B (test signal)	29 31	Makes the clocked voltage available for the individual interface inputs of channel B.	

Signal	Pin	Description	Comments
External enabling 1 channel A	12	For connection of an external 2-channel enabling switch 1 with floating contacts.	If no external enabling switch 1 is connected, channel A pins 11/12 and channel B 29/30 must be jumpered. Only effective in TEST modes. (>>> "Function of external axis enabling switch" Page 96)
External enabling 1 channel B	30		
External enabling 2 channel A	14	For connection of an external 2-channel enabling switch 2 with floating contacts.	If no external enabling switch 2 is connected, channel A pins 13/14 and channel B 31/32 must be jumpered. Only effective in TEST modes. (>>> "Function of external axis enabling switch" Page 96)
External enabling 2 channel B	32		

Function of external axis enabling switch

- External enabling 1
Enabling switch must be pressed for jogging in T1 or T2. Input is closed.
- External enabling 2
Enabling switch is not in the panic position. Input is closed.
- If a smartPAD is connected, its enabling switches and the external enabling are ANDed.

Function (only active for T1 and T2)	External enabling 1	External enabling 2	Switch position
Safety stop 1 (drives switched off when axis at standstill)	Input open	Input open	No operational state
Safety stop 2 (safe operational stop, drives switched on)	Input open	Input closed	Not pressed
Safety stop 1 (drives switched off when axis at standstill)	Input closed	Input open	Panic position
Axes enabled (axis jogging possible)	Input closed	Input closed	Center position

4.6.3 EMERGENCY STOP device on the robot controller (optional)

Description

The EMERGENCY STOP device in the robot controller is connected to X11.

 **WARNING** The EMERGENCY STOP devices on the robot controller must be integrated into the EMERGENCY STOP circuit of the system by the system integrator. Failure to do this may result in death, severe injuries or considerable damage to property.

Circuit example, series connection

The figure (>>> Fig. 4-9) shows a circuit example of the EMERGENCY STOP device connected in series.

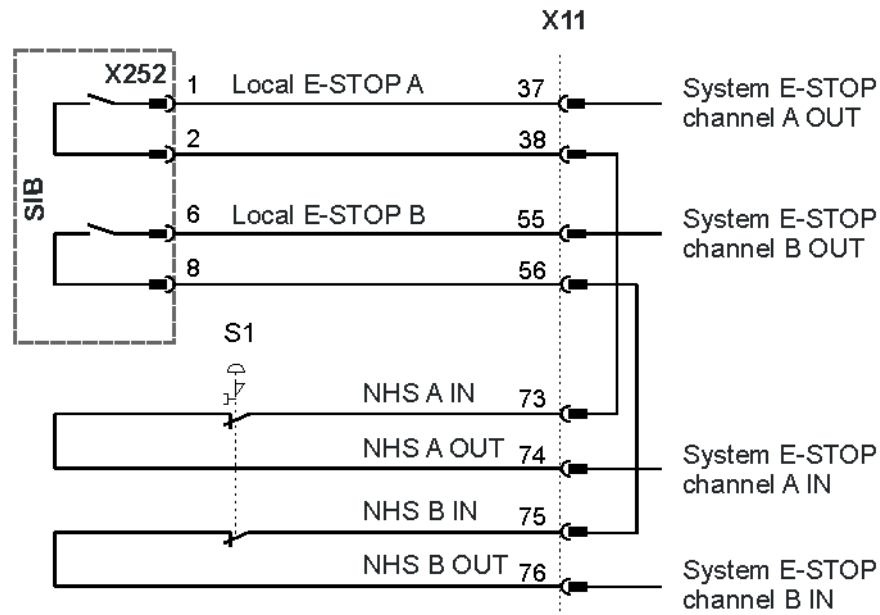

Fig. 4-9: EMERGENCY STOP device, series connection

Circuit example, star configuration

The figure (>>> Fig. 4-10) shows a circuit example of the EMERGENCY STOP device with a star configuration connected to a higher-level controller.

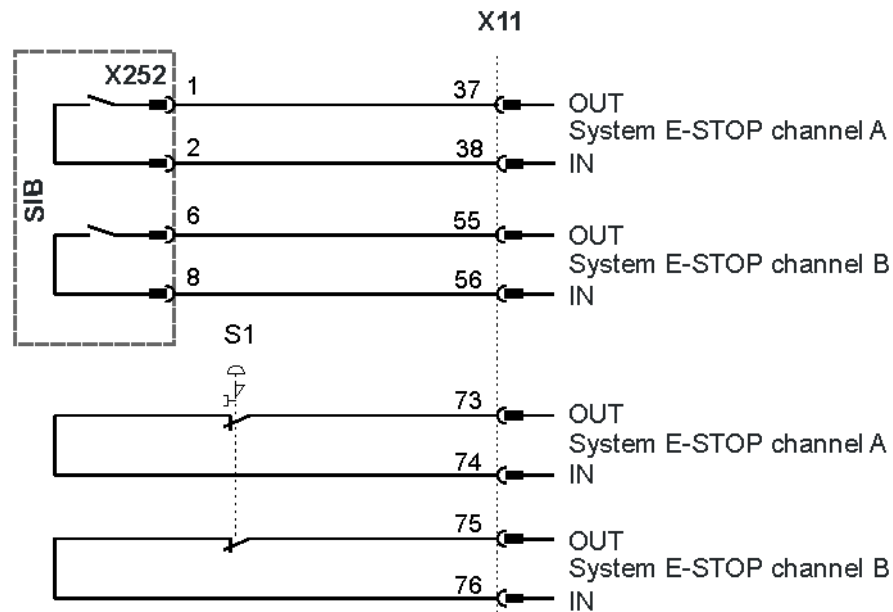

Fig. 4-10: EMERGENCY STOP device, star configuration

4.6.4 Contact diagram for connector X11

Connector X11, contact diagram

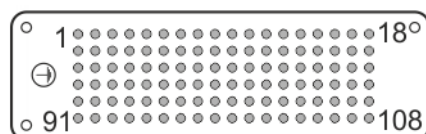

Fig. 4-11: Contact diagram

- X11, mating connector: Han 108DD with a male insert
- Housing size: 24B

- Cable gland M32
- Cable diameter 14-21 mm
- Cable cross-section $\geq 1 \text{ mm}^2$



In the cabling for the input signals and test signals in the system, suitable measures must be taken to prevent a cross-connection between the voltages (e.g. separate cabling of input signals and test signals).



In the cabling for the output signals and test signals in the system, suitable measures must be taken to prevent a cross-connection between the output signals of a channel (e.g. separate cabling).

4.6.5 Wiring example for safe inputs and outputs

Safe input

The switch-off capability of the inputs is monitored cyclically.

The inputs of the SIB are of dual-channel design with external testing. The dual-channel operation of the inputs is monitored cyclically.

The following diagram illustrates the connection of a safe input to a floating contact provided by the customer.

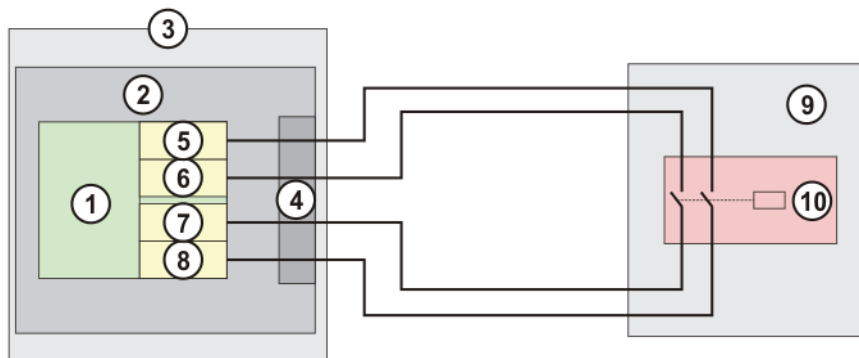

Fig. 4-12: Connection schematic for safe input

- 1 Safe input, SIB
- 2 SIB/CIB
- 3 Robot controller
- 4 Interface X11 (XD211) or X13 (XD213)
- 5 Test output channel B
- 6 Test output channel A
- 7 Input X, channel A
- 8 Input X, channel B
- 9 System side
- 10 Floating contact

Test outputs A and B are fed with the supply voltage of the SIB. Test outputs A and B are sustained short-circuit proof. The test outputs must only be used to supply the SIB inputs, and for no other purpose.

The wiring example described can be used to achieve compliance with Category 3 and Performance Level (PL) d according to EN ISO 13849-1.

Dynamic testing

- The switch-off capability of the inputs is tested cyclically. For this, the test outputs TA_A and TA_B are switched off alternately.
- The switch-off pulse length is defined for the SIBs as $t_1 = 625 \mu\text{s}$ (125 μs – 2.375 ms).

- The duration t_2 between two switch-off pulses on one channel is 106 ms.
- The input channel SIN_x_A must be supplied by the test signal TA_A. The input channel SIN_x_B must be supplied by the test signal TA_B. No other power supply is permissible.
- It is only permitted to connect sensors which allow the connection of test signals and which provide floating contacts.
- The signals TA_A and TA_B must not be significantly delayed by the switching element.

Switch-off pulse diagram

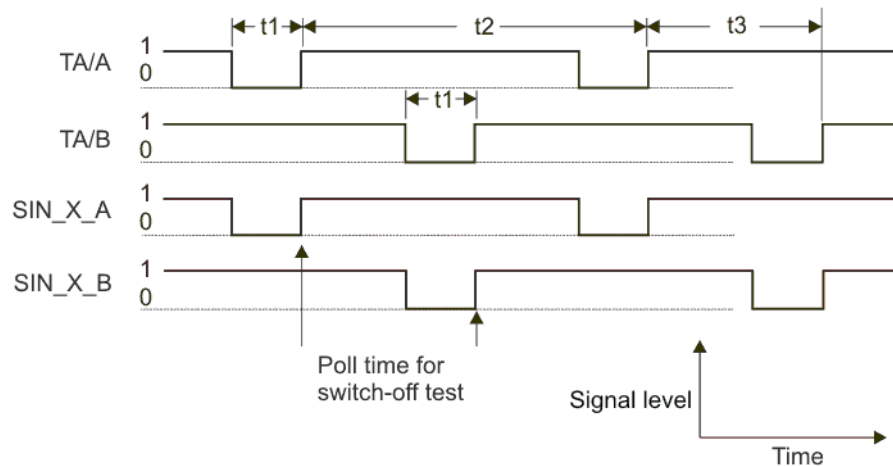

Fig. 4-13: Switch-off pulse diagram, test outputs

- t1 Switch-off pulse length (fixed or configurable)
- t2 Switch-off period per channel (106 ms)
- t3 Offset between switch-off pulses of both channels (53 ms)
- TA/A Test output channel A
- TA/B Test output channel B
- SIN_X_A Input X, channel A
- SIN_X_B Input X, channel B

Safe output

On the SIB, the outputs are provided as dual-channel floating relay outputs.

The following diagram illustrates the connection of a safe output to a safe input provided by the customer with external test facility. The input used by the customer must be monitored externally for cross-connection.

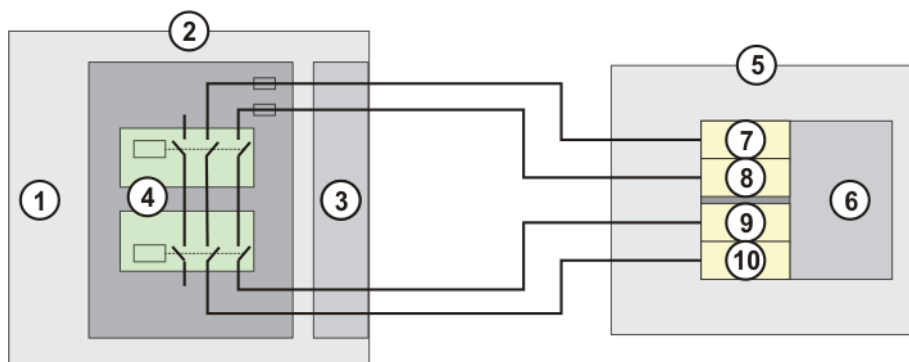

Fig. 4-14: Connection schematic for safe output

- 1 SIB
- 2 Robot controller
- 3 Interface X11 (XD211) or X13 (XD213)
- 4 Output wiring

- 5 System side
- 6 Safe input (Fail Safe PLC, safety switching device)
- 7 Test output channel B
- 8 Test output channel A
- 9 Input X, channel A
- 10 Input X, channel B

The wiring example described can be used to achieve compliance with Category 3 and Performance Level (PL) d according to EN ISO 13849-1.

4.7 Safety functions via Ethernet safety interface (optional)

Description

The exchange of safety-relevant signals between the controller and the system is carried out via the Ethernet safety interface (e.g. PROFIsafe or CIP Safety). The assignment of the input and output states within the Ethernet safety interface protocol are listed below. In addition, non-safety-oriented information from the safety controller is sent to the non-safe section of the higher-level controller for the purpose of diagnosis and control.

Reserved bits

Reserved safe inputs can be pre-assigned by a PLC with the values **0** or **1**. In both cases, the manipulator will move. If a safety function is assigned to a reserved input (e.g. in the case of a software update) and if this input is preset with the value **0**, then the manipulator would either not move or would unexpectedly come to a standstill.



KUKA recommends pre-assignment of the reserved inputs with **1**. If a reserved input has a new safety function assigned to it, and the input is not used by the customer's PLC, the safety function is not activated. This prevents the safety controller from unexpectedly stopping the manipulator.

Input byte 0

Bit	Signal	Description
0	RES	Reserved 1 The value 1 must be assigned to the input.
1	NHE	Input for external Emergency Stop 0 = external E-STOP is active 1 = external E-STOP is not active
2	BS	Operator safety 0 = operator safety is not active, e.g. safety gate open 1 = operator safety is active
3	QBS	Acknowledgement of operator safety Precondition for acknowledgement of operator safety is the signal "Operator safety assured" set in the BS bit. Note: If the "BS" signal is acknowledged by the system, this must be specified under Hardware options in the safety configuration. Information is contained in the Operating and Programming Instructions for System Integrators. 0 = operator safety has not been acknowledged Edge 0 ->1 = operator safety has been acknowledged

Bit	Signal	Description
4	SHS1	<p>Safety STOP 1 (all axes)</p> <ul style="list-style-type: none"> ■ FF (motion enable) is set to 0. ■ Voltage US2 is switched off. ■ AF (drives enable) is set to 0 after 1.5 s. <p>Cancelation of this function does not require acknowledgement.</p> <p>This function is not permissible for the EMERGENCY STOP function.</p> <p>0 = safety stop is active 1 = safety stop is not active</p>
5	SHS2	<p>Safety STOP 2 (all axes)</p> <ul style="list-style-type: none"> ■ FF (motion enable) is set to 0. ■ Voltage US2 is switched off. <p>Cancelation of this function does not require acknowledgement.</p> <p>This function is not permissible for the EMERGENCY STOP function.</p> <p>0 = safety stop is active 1 = safety stop is not active</p>
6	RES	-
7	RES	-

Input byte 1

Bit	Signal	Description
0	US2	<p>Supply voltage US2 (signal for switching the second supply voltage, US2, without battery backup)</p> <p>If this output is not used, it should be set to 0.</p> <p>0 = switch off US2 1 = switch on US2</p> <p>Note: Whether and how input US2 is used must be specified under Hardware options in the safety configuration. Information is contained in the Operating and Programming Instructions for System Integrators.</p>
1	SBH	<p>Safe operational stop (all axes)</p> <p>Precondition: All axes are stationary</p> <p>Cancelation of this function does not require acknowledgement.</p> <p>This function is not permissible for the EMERGENCY STOP function.</p> <p>0 = safe operational stop is active. 1 = safe operational stop is not active.</p>
2	RES	<p>Reserved 11</p> <p>The value 1 must be assigned to the input.</p>
3	RES	<p>Reserved 12</p> <p>The value 1 must be assigned to the input.</p>

Bit	Signal	Description
4	RES	Reserved 13 The value 1 must be assigned to the input.
5	RES	Reserved 14 The value 1 must be assigned to the input.
6	RES	Reserved 15 The value 1 must be assigned to the input.
7	SPA	System Powerdown Acknowledge The system confirms that it has received the power-down signal. A second after the "SP" (System Powerdown) signal has been set by the controller, the requested action is executed, without the need for confirmation from the PLC, and the controller shuts down. 0 = confirmation is not active 1 = confirmation is active

Output byte 0

Bit	Signal	Description
0	NHL	Local E-STOP (local E-STOP triggered) 0 = local E-STOP is active 1 = local E-STOP is not active
1	AF	Drives enable (the internal safety controller in the KRC has enabled the drives so that they can be switched on) 0 = drives enable is not active (the robot controller must switch the drives off) 1 = drives enable is active (the robot controller must switch the drives to servo-control)
2	FF	Motion enable (the internal safety controller in the KRC has enabled robot motions) 0 = motion enable is not active (the robot controller must stop the current motion) 1 = motion enable is active (the robot controller may trigger a motion)
3	ZS	One of the enabling switches is in the center position (enabling in test mode) 0 = enabling is not active 1 = enabling is active
4	PE	The signal "Peri enabled" is set to 1 (active) if the following conditions are met: <ul style="list-style-type: none"> ■ Drives are switched on. ■ Safety controller motion enable signal present. ■ The message "Operator safety open" must not be active. (>>> "Signal "Peri enabled" (PE)" Page 94)
5	AUT	The manipulator is in AUT or AUT EXT mode. 0 = AUT or AUT EXT mode is not active 1 = AUT or AUT EXT mode is active

Bit	Signal	Description
6	T1	The manipulator is in Manual Reduced Velocity mode. 0 = T1 mode is not active 1 = T1 mode is active
7	T2	The manipulator is in Manual High Velocity mode. 0 = T2 mode is not active 1 = T2 mode is active

Output byte 1

Bit	Signal	Description
0	NHE	External E-STOP has been triggered. 0 = external E-STOP is active 1 = external E-STOP is not active
1	BS	Operator safety 0 = operator safety is not assured 1 = operator safety is assured (input BS = 1 and, if configured, input QBS acknowledged)
2	SHS1	Safety stop 1 (all axes) 0 = Safety stop 1 is not active 1 = Safety stop 1 is active (safe state reached)
3	SHS2	Safety stop 2 (all axes) 0 = Safety stop 2 is not active 1 = Safety stop 2 is active (safe state reached)
4	RES	Reserved 13
5	RES	Reserved 14
6	PSA	Safety interface active Precondition: An Ethernet interface must be installed on the controller, e.g. PROFINET or Ethernet/IP 0 = safety interface is not active 1 = safety interface is active
7	SP	System Powerdown (controller will be shut down) One second after the SP signal has been set, the PSA output is reset by the robot controller, without confirmation from the PLC, and the controller is shut down. 0 = controller on safety interface is active. 1 = controller will be shut down

4.7.1 Schematic circuit diagram for enabling switches**Description**

An external enabling switch can be connected to the higher-level safety controller. The signals (ZSE make contact and External panic break contact) must be correctly linked to the Ethernet safety interface signals in the safety controller. The resulting Ethernet safety interface signals must then be routed to the PROFIsafe of the KR C4. The response to the external enabling switch is then identical to that for a discretely connected X11.

Signals

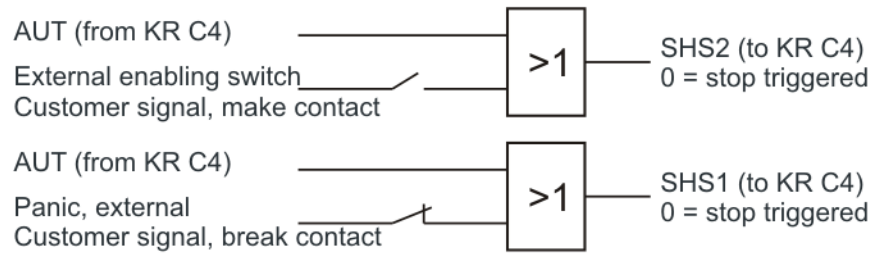

Fig. 4-15: Schematic circuit diagram of external enabling switch

- Enabling switch center position (make contact closed (1) = enabled) OR AUT at SHS2
- Panic (break contact open (0) = panic position) = AND not AUT at SHS1

4.7.2 SafeOperation via Ethernet safety interface (optional)

Description

The components of the industrial robot move within the limits that have been configured and activated. The actual positions are continuously calculated and monitored against the safety parameters that have been set. The safety controller monitors the industrial robot by means of the safety parameters that have been set. If a component of the industrial robot violates a monitoring limit or a safety parameter, the manipulator and external axes (optional) are stopped. The Ethernet safety interface can be used, for example, to signal a violation of safety monitoring functions.

In the case of the KR C4 compact robot controller, safety options such as SafeOperation are only available via the Ethernet safety interface from KSS/VSS 8.3 onwards.

Reserved bits

Reserved safe inputs can be pre-assigned by a PLC with the values **0** or **1**. In both cases, the manipulator will move. If a safety function is assigned to a reserved input (e.g. in the case of a software update) and if this input is preset with the value **0**, then the manipulator would either not move or would unexpectedly come to a standstill.

i KUKA recommends pre-assignment of the reserved inputs with **1**. If a reserved input has a new safety function assigned to it, and the input is not used by the customer's PLC, the safety function is not activated. This prevents the safety controller from unexpectedly stopping the manipulator.

Input byte 2

Bit	Signal	Description
0	JR	Mastering test (input for the reference switch of the mastering test) 0 = reference switch is active (actuated). 1 = reference switch is not active (not actuated).

Bit	Signal	Description
1	VRED	Reduced axis-specific and Cartesian velocity (activation of reduced velocity monitoring) 0 = reduced velocity monitoring is active. 1 = reduced velocity monitoring is not active.
2 ... 7	SBH1 ... 6	Safe operational stop for axis group 1 ... 6 Assignment: Bit 2 = axis group 1 ... bit 7 = axis group 6 Signal for safe operational stop. The function does not trigger a stop, it only activates the safe standstill monitoring. Cancellation of this function does not require acknowledgement. 0 = safe operational stop is active. 1 = safe operational stop is not active.

Input byte 3

Bit	Signal	Description
0 ... 7	RES	Reserved 25 ... 32 The value 1 must be assigned to the inputs.

Input byte 4

Bit	Signal	Description
0 ... 7	UER1 ... 8	Monitoring spaces 1 ... 8 Assignment: Bit 0 = monitoring space 1 ... bit 7 = monitoring space 8 0 = monitoring space is active. 1 = monitoring space is not active.

Input byte 5

Bit	Signal	Description
0 ... 7	UER9 ... 16	Monitoring spaces 9 ... 16 Assignment: Bit 0 = monitoring space 9 ... bit 7 = monitoring space 16 0 = monitoring space is active. 1 = monitoring space is not active.

Input byte 6

Bit	Signal	Description
0 ... 7	WZ1 ... 8	Tool selection 1 ... 8 Assignment: Bit 0 = tool 1 ... bit 7 = tool 8 0 = tool is not active. 1 = tool is active. Exactly one tool must be selected at all times.

Input byte 7

Bit	Signal	Description
0 ... 7	WZ9 ... 16	Tool selection 9 ... 16 Assignment: Bit 0 = tool 9 ... bit 7 = tool 16 0 = tool is not active. 1 = tool is active. Exactly one tool must be selected at all times.

Output byte 2

Bit	Signal	Description
0	SO	Safety option active SafeOperation activation status 0 = safety option is not active 1 = safety option is active
1	RR	Manipulator referenced Mastering test display 0 = mastering test required. 1 = mastering test performed successfully.
2	JF	Mastering error Space monitoring is deactivated because at least one axis is not mastered. 0 = mastering error. Space monitoring has been deactivated. 1 = no error.
3	VRED	Reduced axis-specific and Cartesian velocity (activation status of reduced velocity monitoring) 0 = reduced velocity monitoring is not active. 1 = reduced velocity monitoring is active.
4 ... 7	SBH1 ... 4	Activation status of safe operational stop for axis group 1 ... 4 Assignment: Bit 4 = axis group 1 ... bit 7 = axis group 4 0 = safe operational stop is not active. 1 = safe operational stop is active.

Output byte 3

Bit	Signal	Description
0 ... 1	SBH5 ... 6	Activation status of safe operational stop for axis group 5 ... 6 Assignment: Bit 0 = axis group 5 ... bit 1 = axis group 6 0 = safe operational stop is not active. 1 = safe operational stop is active.
2 ... 7	RES	Reserved 27 ... 32

Output byte 4

Bit	Signal	Description
0 ... 7	MR1 ... 8	Alarm space 1 ... 8 Assignment: Bit 0 = alarm space 1 (associated monitoring space 1) ... bit 7 = alarm space 8 (associated monitoring space 8) 0 = monitoring space is violated. 1 = monitoring space is not violated. Note: An inactive monitoring space is considered to be violated by default, i.e. in this case the associated safe output MRx has the state "0".

Output byte 5

Bit	Signal	Description
0 ... 7	MR9 ... 16	Alarm space 9 ... 16 Assignment: Bit 0 = alarm space 9 (associated monitoring space 9) ... bit 7 = alarm space 16 (associated monitoring space 16) 0 = monitoring space is violated. 1 = monitoring space is not violated. Note: An inactive monitoring space is considered to be violated by default, i.e. in this case the associated safe output MRx has the state "0".

Output byte 6

Bit	Signal	Description
0 ... 7	RES	Reserved 49 ... 56

Output byte 7

Bit	Signal	Description
0 ... 7	RES	Reserved 57 ... 64

4.8 EtherCAT connection on the CIB**Description**

Connector X44 on the CIB is the interface for connection of EtherCAT slaves inside the robot controller (on the mounting plate for customer components). The EtherCAT line remains in the robot controller. The EtherCAT line can be routed out of the robot controller via the optional connector X65. Information about connector X65 can be found in the assembly and operating instructions of the optional KR C4 interfaces.

 The EtherCAT devices must be configured with WorkVisual.

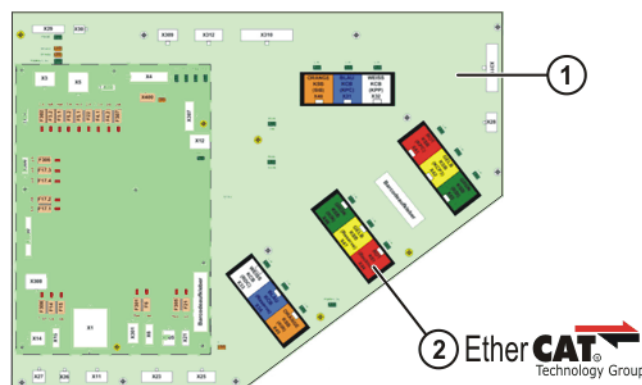
**Fig. 4-16: EtherCAT connection X44**

- 1 CIB
- 2 EtherCAT connection X44

4.9 PE equipotential bonding**Description**

The following cables must be connected before start-up:

- A 16 mm² cable as equipotential bonding between the manipulator and the robot controller.

- An additional PE conductor between the central PE rail of the supply cabinet and the PE bolt of the robot controller. A cross section of 16 mm² is recommended.

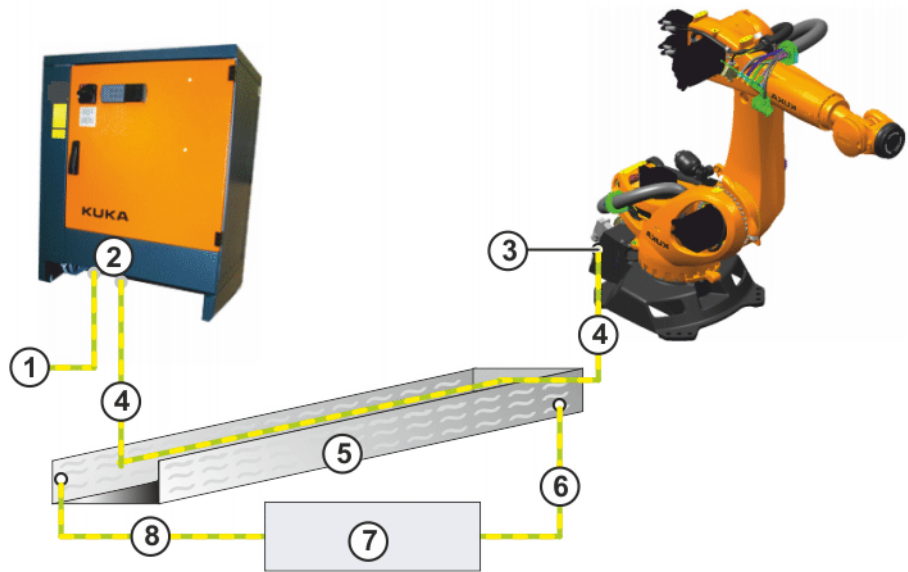

Fig. 4-17: Equipotential bonding from robot controller to manipulator via cable duct

- 1 PE to central PE rail of the supply cabinet
- 2 Connection panel on robot controller
- 3 Equipotential bonding connection on the manipulator
- 4 Equipotential bonding from the robot controller to the manipulator
- 5 Cable duct
- 6 Equipotential bonding from the start of the cable duct to the main equipotential bonding
- 7 Main equipotential bonding
- 8 Equipotential bonding from the end of the cable duct to the main equipotential bonding

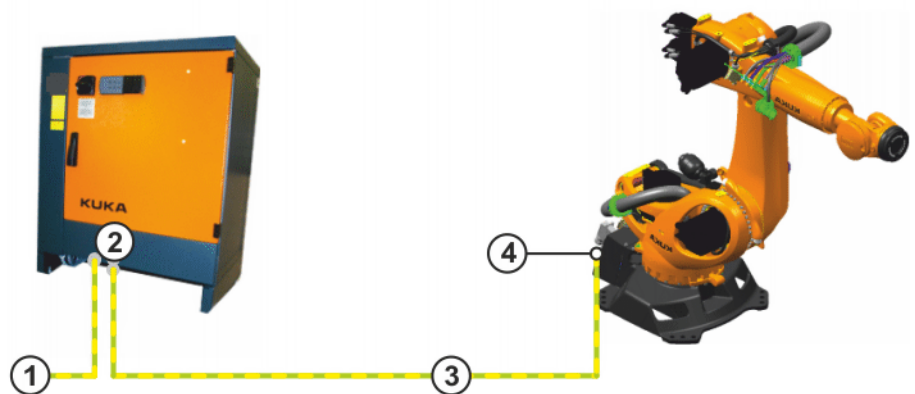



Fig. 4-18: Equipotential bonding, robot controller - manipulator

- 1 PE to central PE rail of the supply cabinet
- 2 Connection panel on robot controller
- 3 Equipotential bonding from the robot controller to the manipulator
- 4 Equipotential bonding connection on the manipulator

4.10 Modifying the system configuration, exchanging devices

Description	<p>The system configuration of the industrial robot must be configured using WorkVisual in the following cases:</p> <ul style="list-style-type: none"> ■ Installation of KSS/VSS 8.2 or higher <p>This is the case if KSS/VSS 8.2 or higher is installed without KSS/VSS 8.2 or higher already being present (because it has been uninstalled or deleted or has never been installed).</p> ■ The hard drive has been exchanged. ■ A device has been replaced by a device of a different type. ■ More than one device has been replaced by a device of a different type. ■ One or more devices have been removed. ■ One or more devices have been added.
Exchanging devices	<p>If a device is exchanged, at least one KCB, KSB or KEB device is replaced by a device of the same type. Any number of KCB, KSB and KEB devices can be exchanged until all devices in the KCB, KSB and KEB have been replaced simultaneously by devices of the same type. Simultaneous exchange of two identical components of the KCB is not possible. Only one of the identical components may be exchanged at any one time.</p>

	The interchanging of 2 identical devices can only occur in the case of the KSP3x40 if the current system configuration contains 2 KSP3x40.
---	--

4.11 Operator safety acknowledgement

A dual-channel acknowledge button must be installed outside the physical safeguard. The closing of the safety gate must be confirmed by pressing the acknowledge button before the industrial robot can be started again in Automatic mode.

4.12 Performance level

The safety functions of the robot controller conform to category 3 and Performance Level d according to EN ISO 13849-1.

4.12.1 PFH values of the safety functions

The safety values are based on a service life of 20 years.

The PFH value classification of the controller is only valid if the E-STOP device is tested at least once every 6 months.

When evaluating system safety functions, it must be remembered that the PFH values for a combination of multiple controllers may have to be taken into consideration more than once. This is the case for RoboTeam systems or higher-level hazard areas. The PFH value determined for the safety function at system level must not exceed the limit for PL d.

The PFH values relate to the specific safety functions of the different controller variants.

Safety function groups:

- Standard safety functions
 - Operating mode selection
 - Operator safety

- EMERGENCY STOP device
- Enabling device
- External safe operational stop
- External safety stop 1
- External safety stop 2
- Velocity monitoring in T1
- Control of the peripheral contactor
- Safety functions of KUKA.SafeOperation (option)
 - Monitoring of axis spaces
 - Monitoring of Cartesian spaces
 - Monitoring of axis velocity
 - Monitoring of Cartesian velocity
 - Monitoring of axis acceleration
 - Safe operational stop
 - Tool monitoring

Overview of controller variant PFH values:

Robot controller variant	PFH value
KR C4; KR C4 CK	$< 1 \times 10^{-7}$
KR C4 midsize; KR C4 midsize CK	$< 1 \times 10^{-7}$
KR C4 extended; KR C4 extended CK	$< 1 \times 10^{-7}$
KR C4 NA; KR C4 CK NA	$< 1 \times 10^{-7}$
KR C4 NA variant: TTE1	$< 1 \times 10^{-7}$
KR C4 extended NA; KR C4 extended CK NA	$< 1 \times 10^{-7}$
KR C4 variant: TBM1	$< 1 \times 10^{-7}$
KR C4 variants: TDA1; TDA2; TDA3; TDA4	$< 1 \times 10^{-7}$
KR C4 variants: TFO1; TFO2	$< 2 \times 10^{-7}$
KR C4 variants: TRE1; TRE2	$< 1.5 \times 10^{-7}$
KR C4 variant: TRE3	$< 1 \times 10^{-7}$
KR C4 variants: TVO1; TVO2; TVO3	$< 1 \times 10^{-7}$
VKR C4 variants: TVW1; TVW2; TVW3; TVW4	$< 1 \times 10^{-7}$
VKR C4 Retrofit	
<ul style="list-style-type: none"> ■ Without external EMERGENCY STOP and operator safety functions ■ External EMERGENCY STOP and operator safety functions 	$< 1 \times 10^{-7}$ 5×10^{-7}

 For controller variants that are not listed here, please contact KUKA Roboter GmbH.

5 Transportation

5.1 Transportation using lifting tackle

- Precondition**
- The robot controller must be switched off.
 - No cables may be connected to the robot controller.
 - The door of the robot controller must be closed.
 - The robot controller must be upright.
 - The anti-toppling bracket must be fastened to the robot controller.

Necessary equipment Lifting tackle with or without lifting frame.

- Procedure**
1. Attach the lifting tackle with or without a lifting frame to all 4 transport eyebolts on the robot controller.

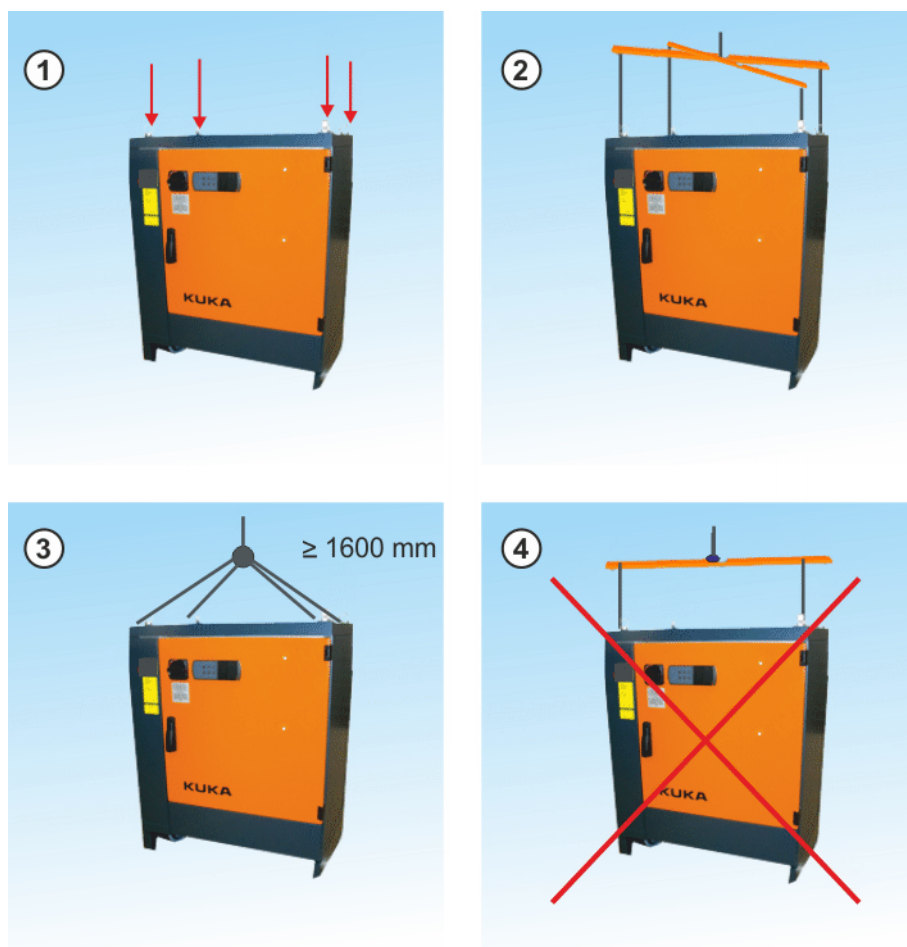

Fig. 5-1: Transportation using lifting tackle

- 1 Transport eyebolts on the robot controller
 - 2 Correctly attached lifting tackle
 - 3 Correctly attached lifting tackle
 - 4 Incorrectly attached lifting tackle
2. Attach the lifting tackle to the crane.

WARNING If the suspended robot controller is transported too quickly, it may swing and cause injury or damage. Transport the robot controller slowly.

3. Slowly lift and transport the robot controller.
4. Slowly lower the robot controller at its destination.
5. Unhook lifting tackle on the robot controller.

5.2 Transportation by fork lift truck

Precondition

- The robot controller must be switched off.
- No cables may be connected to the robot controller.
- The door of the robot controller must be closed.
- The robot controller must be upright.
- The anti-toppling bracket must be fastened to the robot controller.

Procedure

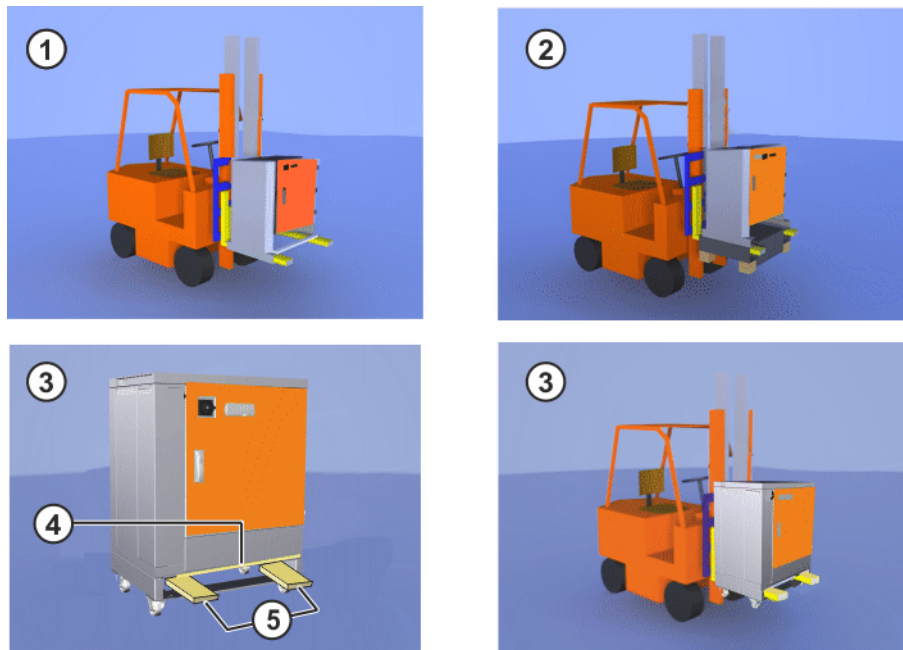

Fig. 5-2: Transportation by fork lift truck

- 1 Robot controller with fork slots
- 2 Robot controller with transformer installation kit
- 3 Robot controller with set of rollers
- 4 Anti-toppling bracket
- 5 Forks of the fork lift truck

5.3 Transportation by pallet truck

Precondition

- The robot controller must be switched off.
- No cables may be connected to the robot controller.
- The door of the robot controller must be closed.
- The robot controller must be upright.
- The anti-toppling bracket must be fastened to the robot controller.

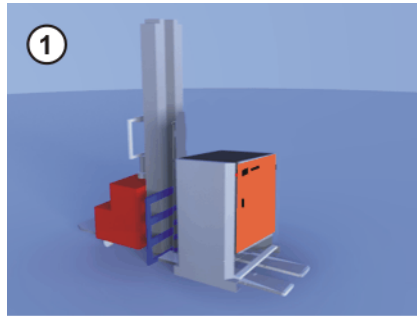
Procedure**Fig. 5-3: Transportation by pallet truck**

- 1 Robot controller with anti-toppling bracket

5.4 Transportation with the set of rollers**Description**

The robot controller rollers may only be used to roll the cabinet into and out of a row of cabinets – not to transport the cabinet over longer distances. The floor must be level and free from obstacles, as there is a permanent risk of toppling.

NOTICE	If the robot controller is towed by a vehicle (fork lift truck, electrical vehicle), this can result in damage to the rollers and to the robot controller. The robot controller must not be hitched to a vehicle and transported using its rollers.
---------------	---

6 Start-up and recommissioning

6.1 Installing the robot controller

- Procedure**
1. Install the robot controller. The minimum clearances to walls, other cabinets, etc. must be observed. (>>> 4.2 "Installation conditions" Page 87)
 2. Check the robot controller for any damage caused during transportation.
 3. Check that fuses, contactors and boards are fitted securely.
 4. Secure any modules that have come loose.
 5. Check that all screwed and clamped connections are securely fastened.
 6. The operator must cover the warning label **Read manual** with the label in the relevant local language. (>>> 2.8 "Plates and labels" Page 59)

6.2 Connecting the connecting cables

- Overview**
- A connecting cable set is supplied with the industrial robot. In the standard version this consists of:
 - Motor cables to the manipulator
 - Data cables to the manipulator
 - The following cables may be provided for additional applications:
 - Motor cables for external axes
 - Peripheral cables



The robot controller is preconfigured for the specific industrial robot. If cables are interchanged, the manipulator and the external axes (optional) may receive incorrect data and can thus cause personal injury or material damage. If a system consists of more than one manipulator, always connect the connecting cables to the manipulators and their corresponding robot controllers.

- Bending radius**
- The following bending radii must be observed:
- Fixed installation: 3 ... 5 x cable diameter.
 - Installation in cable carrier: 7 ... 10 x cable diameter (cable must be specified for this).

- Procedure**
1. Route and connect the motor cables to the manipulator junction box separately from the data cables.
 2. Route and connect the motor cables of the external axes.
 3. Route the data cables to the manipulator junction box separately from the motor cable. Plug in connector X21.
 4. Connect the peripheral cables.

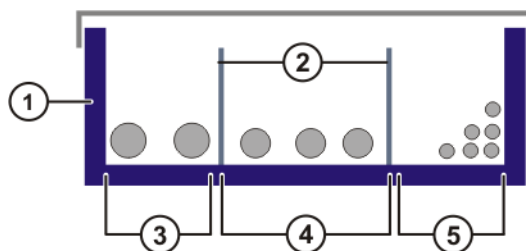

Fig. 6-1: Example: Installing the cables in the cable duct

- 1 Cable duct
- 2 Separating webs
- 3 Welding cables
- 4 Motor cables
- 5 Data cables

6.2.1 Data cables, X21

Connector pin allocation

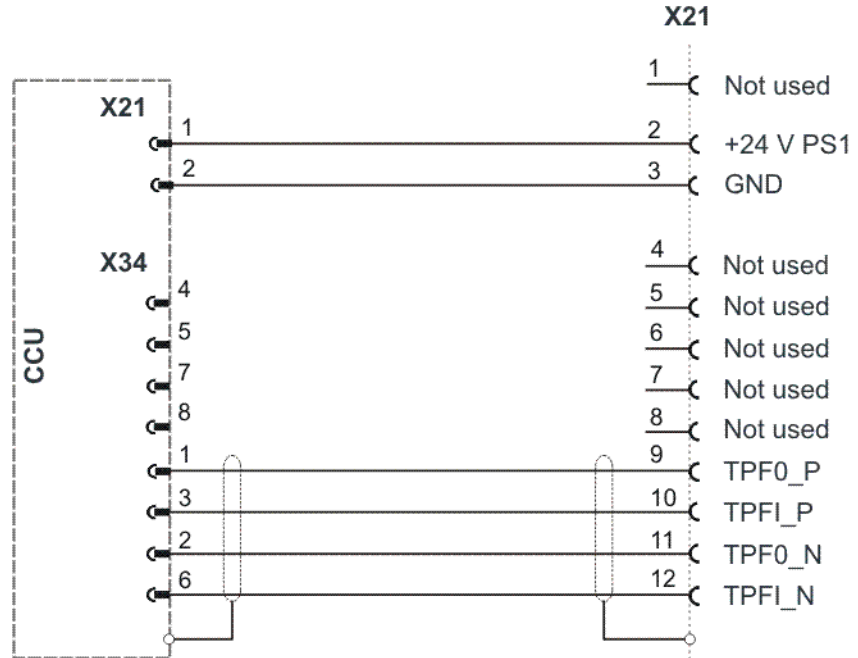

Fig. 6-2: Connector pin allocation for X21

6.3 Fastening the KUKA smartPAD holder (optional)

- Procedure**
- Fasten the smartPAD holder on the door of the robot controller or on the wall. (>>> 4.4 "Fastening the KUKA smartPAD holder (optional)" Page 90)

6.4 Plugging in the KUKA smartPAD

- Procedure**
- Plug the KUKA smartPAD to X19 on the robot controller.

WARNING If the smartPAD is disconnected, the system can no longer be switched off by means of the EMERGENCY STOP device on the smartPAD. For this reason, an external EMERGENCY STOP must be connected to the robot controller. The user is responsible for ensuring that the smartPAD is immediately removed from the system when it has been disconnected. The smartPAD must be stored out of sight and reach of personnel working on the industrial robot. This prevents operational and non-operational EMERGENCY STOP devices from becoming interchanged. Failure to observe these precautions may result in death, injuries or damage to property.

Connector pin allocation X19

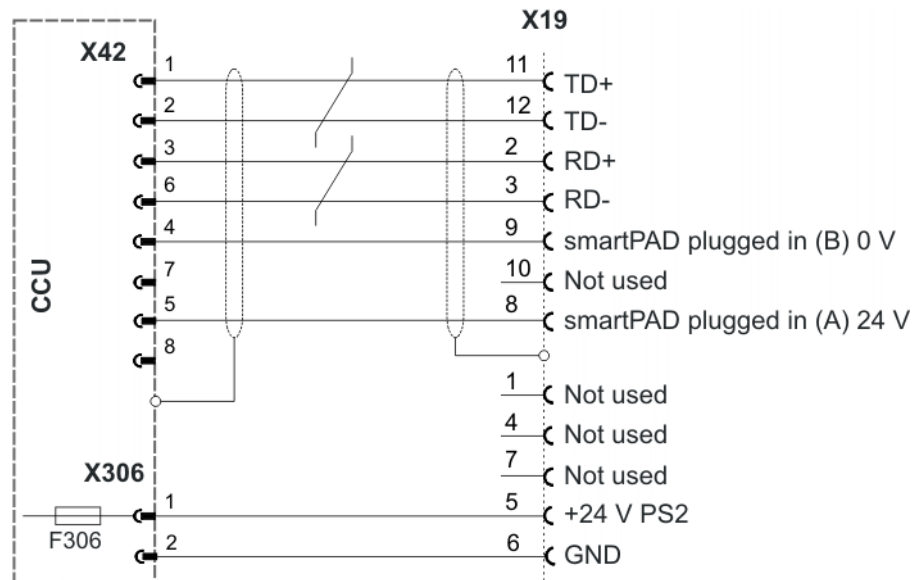

Fig. 6-3: Connector pin allocation X19

6.5 Connecting the PE equipotential bonding

Procedure

1. Connect an additional PE conductor between the central PE rail of the supply cabinet and the PE bolt of the robot controller.
2. Connect a 16 mm² cable as equipotential bonding between the manipulator and the robot controller.
(>>> 4.9 "PE equipotential bonding" Page 107)
3. Carry out a ground conductor check for the entire industrial robot in accordance with DIN EN 60204-1.

6.6 Connecting the robot controller to the power supply

Connection assignment Q1

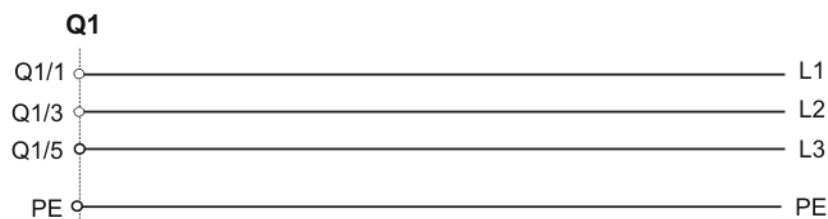

Fig. 6-4: Connection assignment

Precondition

- The power supply connection cable to the robot controller must be de-energized.

WARNING The power supply connection cable must not be energized. Mains voltage can cause life-threatening injuries.

! Work on the electrical and mechanical equipment of the robot system may only be carried out by specially trained personnel.

Procedure

1. Open the door lock and set the rotary main switch to the Reset position. Open the door.

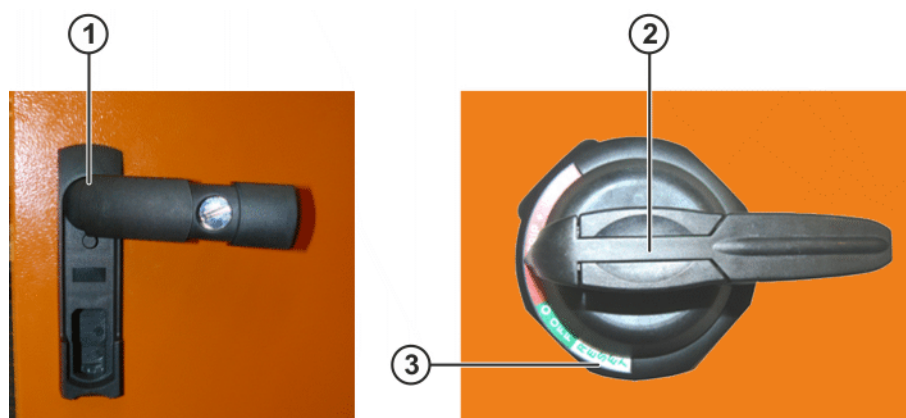

Fig. 6-5: Door lock and main switch position

- 1 Door lock
 - 2 Rotary main switch
 - 3 Rotary main switch Reset position
2. Remove main switch covers.
Pull off upper cover.
Release and remove rotary actuator fastening.
Release and remove auxiliary switch cover fastening.
Release and pull off the cover of the rear cable connections.

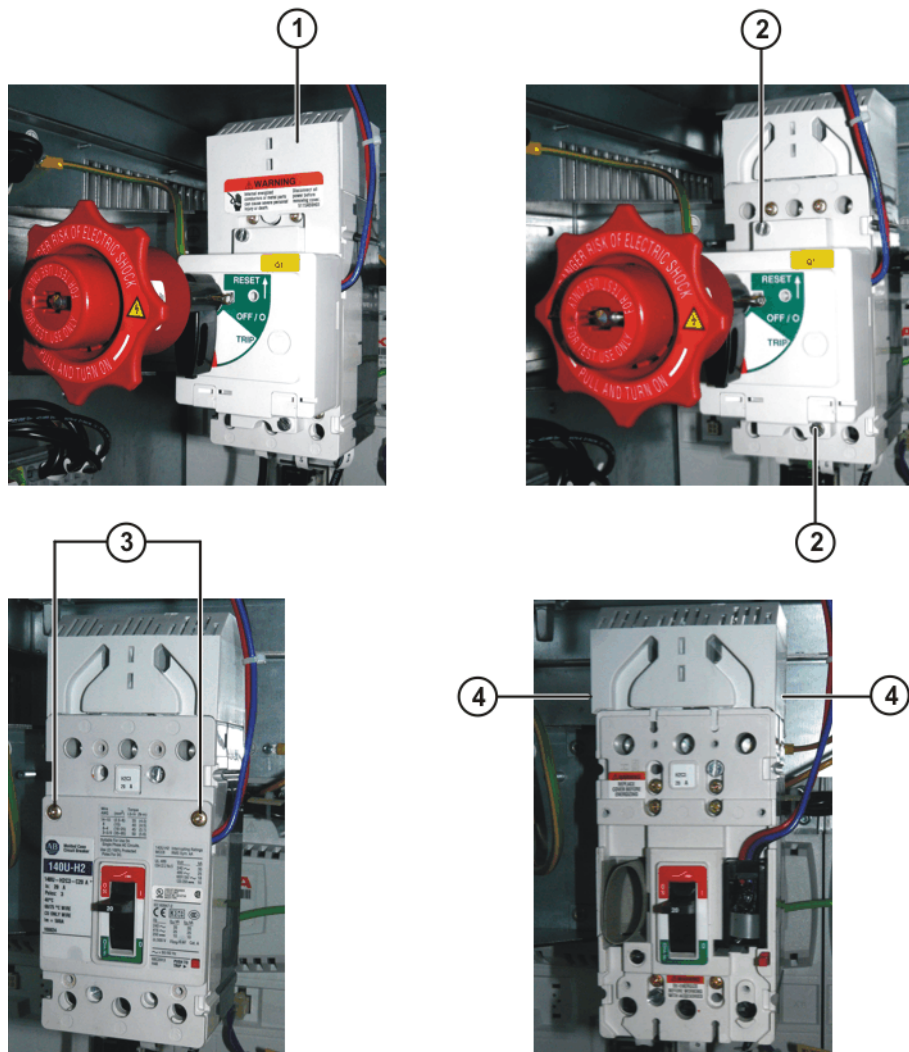

Fig. 6-6: Main switch covers

- 1 Upper cover
 - 2 Rotary actuator fastening
 - 3 Auxiliary switch cover fastening
 - 4 Cable connections cover
3. Feed the power supply connection cable into the M32 cable gland and route it to the main switch. Tighten the strain relief.
 4. Connect the 3 phases to the main switch terminals.
 5. Connect the ground conductor to the PE connecting bolt.

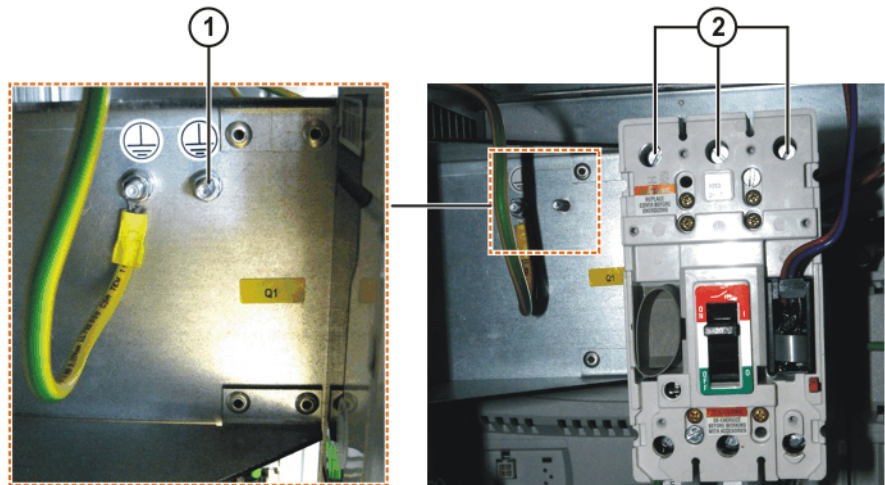

Fig. 6-7: Main switch connections

- 1 PE connecting bolt
 - 2 Main switch terminals
6. Fasten all main switch covers.

6.7 Reversing the battery discharge protection measures

Description

To prevent the batteries from discharging before the controller has been started up for the first time, the robot controller is supplied with connector X305 disconnected from the CCU.

Procedure

- Plug connector X305 into the CCU.

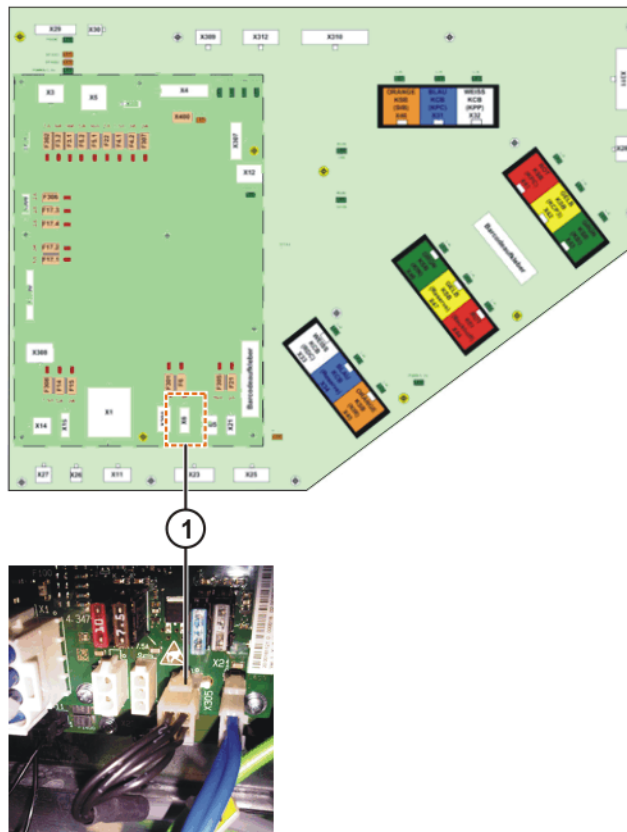

Fig. 6-8: Battery discharge protection X305

1 Connector X305 on the CCU

6.8 Configuring and connecting safety interface X11

Precondition ■ The robot controller is switched off.

Procedure

1. Configure connector X11 in accordance with the system and safety concepts. (>>> 4.6 "Description of safety interface X11" Page 91)
2. Connect interface connector X11 to the robot controller.

NOTICE	Connector X11 may only be plugged in or unplugged when the robot controller is switched off. If connector X11 is plugged in or unplugged when energized, damage to property may occur.
---------------	--

6.9 Modifying the system configuration, exchanging devices

Description The system configuration of the industrial robot must be configured using WorkVisual in the following cases:

- Installation of KSS/VSS 8.2 or higher
This is the case if KSS/VSS 8.2 or higher is installed without KSS/VSS 8.2 or higher already being present (because it has been uninstalled or deleted or has never been installed).
- The hard drive has been exchanged.
- A device has been replaced by a device of a different type.
- More than one device has been replaced by a device of a different type.
- One or more devices have been removed.
- One or more devices have been added.

6.10 Start-up mode

Description The industrial robot can be set to Start-up mode via the smartHMI user interface. In this mode, the manipulator can be moved in T1 without the external safeguards being put into operation.

When Start-up mode is possible depends on the safety interface that is used.

If a discrete safety interface is used:

- System Software 8.2 or earlier:
Start-up mode is always possible if all input signals at the discrete safety interface have the state "logic zero". If this is not the case, the robot controller prevents or terminates Start-up mode.

If an additional discrete safety interface for safety options is used, the inputs there must also have the state "logic zero".

- System Software 8.3:
Start-up mode is always possible. This also means that it is independent of the state of the inputs at the discrete safety interface.

If an additional discrete safety interface for safety options is used: the states of these inputs are not relevant either.

If the Ethernet safety interface is used:

The robot controller prevents or terminates Start-up mode if a connection to a higher-level safety system exists or is established.

Hazards

Possible hazards and risks involved in using Start-up mode:

- A person walks into the manipulator's danger zone.
- In a hazardous situation, a disabled external EMERGENCY STOP device is actuated and the manipulator is not shut down.

Additional measures for avoiding risks in Start-up mode:

- Cover disabled EMERGENCY STOP devices or attach a warning sign indicating that the EMERGENCY STOP device is out of operation.
- If there is no safety fence, other measures must be taken to prevent persons from entering the manipulator's danger zone, e.g. use of warning tape.



External safeguards are disabled in Start-up mode. Observe the safety instructions relating to Start-up mode. (>>> 3.8.3.2 "Start-up mode" Page 79)

In Start-up mode, the system switches to the following simulated input image:

- The external EMERGENCY STOP is not active.
- The safety gate is open.
- No safety stop 1 has been requested.
- No safety stop 2 has been requested.
- No safe operational stop has been requested.
- Only for VKR C4: E2 is closed.

If SafeOperation or SafeRangeMonitoring is used, Start-up mode also influences other signals.



Information about the effects of Start-up mode in conjunction with SafeOperation or SafeRangeMonitoring can be found in the documentation **SafeOperation** and **SafeRangeMonitoring**.

Mapping of standard signals:

Byte 0: 0100 1110

Byte 1: 0100 0000

SafeOperation or SafeRangeMonitoring signal mapping:

Byte 2: 1111 1111

Byte 3: 1111 1111

Byte 4: 1111 1111

Byte 5: 1111 1111

Byte 6: 1000 0000

Byte 7: 0000 0000

6.11 Switching on the robot controller**Preconditions**

- The door of the robot controller is closed.
- All electrical connections are correct and the power supply is within the specified limits.
- It must be ensured that no persons or objects are present within the danger zone of the manipulator.
- All safety devices and protective measures are complete and fully functional.
- The internal temperature of the cabinet must have adapted to the ambient temperature.



We recommend that all motions of the manipulator should be triggered from outside the safety fencing.

Procedure

1. Switch on the mains power to the robot controller.
2. Release the E-STOP device on the KUKA smartPAD.
3. Turn the rotary main switch to ON.

The control PC begins to run up the operating system and the control software.

Switching off

The main switch can be switched off with the door open. To switch it off, turn the red rotary switch counterclockwise.

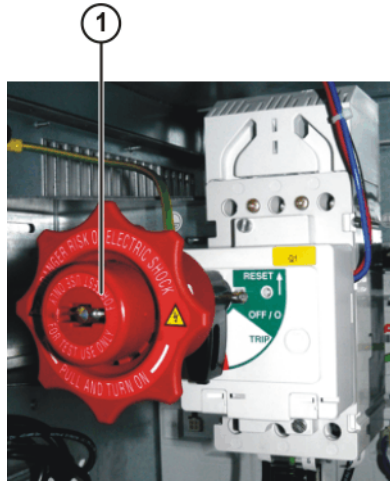

Fig. 6-9: Main switch with door open

- 1 Red rotary switch on main switch

7 KUKA Service

7.1 Requesting support

Introduction	This documentation provides information on operation and operator control, and provides assistance with troubleshooting. For further assistance, please contact your local KUKA subsidiary.
Information	<p>The following information is required for processing a support request:</p> <ul style="list-style-type: none"> ■ Model and serial number of the manipulator ■ Model and serial number of the controller ■ Model and serial number of the linear unit (if present) ■ Model and serial number of the energy supply system (if present) ■ Version of the system software ■ Optional software or modifications ■ Diagnostic package KrcDiag: Additionally for KUKA Sunrise: Existing projects including applications For versions of KUKA System Software older than V8: Archive of the software (KrcDiag is not yet available here.) ■ Application used ■ External axes used ■ Description of the problem, duration and frequency of the fault

7.2 KUKA Customer Support

Availability	KUKA Customer Support is available in many countries. Please do not hesitate to contact us if you have any questions.
Argentina	<p>Ruben Costantini S.A. (Agency) Luis Angel Huergo 13 20 Parque Industrial 2400 San Francisco (CBA) Argentina Tel. +54 3564 421033 Fax +54 3564 428877 ventas@costantini-sa.com</p>
Australia	<p>Headland Machinery Pty. Ltd. Victoria (Head Office & Showroom) 95 Highbury Road Burwood Victoria 31 25 Australia Tel. +61 3 9244-3500 Fax +61 3 9244-3501 vic@headland.com.au www.headland.com.au</p>

Belgium	KUKA Automatisering + Robots N.V. Centrum Zuid 1031 3530 Houthalen Belgium Tel. +32 11 516160 Fax +32 11 526794 info@kuka.be www.kuka.be
Brazil	KUKA Roboter do Brasil Ltda. Travessa Claudio Armando, nº 171 Bloco 5 - Galpões 51/52 Bairro Assunção CEP 09861-7630 São Bernardo do Campo - SP Brazil Tel. +55 11 4942-8299 Fax +55 11 2201-7883 info@kuka-roboter.com.br www.kuka-roboter.com.br
Chile	Robotec S.A. (Agency) Santiago de Chile Chile Tel. +56 2 331-5951 Fax +56 2 331-5952 robotec@robotec.cl www.robotec.cl
China	KUKA Robotics China Co.,Ltd. Songjiang Industrial Zone No. 388 Minshen Road 201612 Shanghai China Tel. +86 21 6787-1888 Fax +86 21 6787-1803 www.kuka-robotics.cn
Germany	KUKA Roboter GmbH Zugspitzstr. 140 86165 Augsburg Germany Tel. +49 821 797-4000 Fax +49 821 797-1616 info@kuka-roboter.de www.kuka-roboter.de

France KUKA Automatismes + Robotique SAS
Techvallée
6, Avenue du Parc
91140 Villebon S/Yvette
France
Tel. +33 1 6931660-0
Fax +33 1 6931660-1
commercial@kuka.fr
www.kuka.fr

India KUKA Robotics India Pvt. Ltd.
Office Number-7, German Centre,
Level 12, Building No. - 9B
DLF Cyber City Phase III
122 002 Gurgaon
Haryana
India
Tel. +91 124 4635774
Fax +91 124 4635773
info@kuka.in
www.kuka.in

Italy KUKA Roboter Italia S.p.A.
Via Pavia 9/a - int.6
10098 Rivoli (TO)
Italy
Tel. +39 011 959-5013
Fax +39 011 959-5141
kuka@kuka.it
www.kuka.it

Japan KUKA Robotics Japan K.K.
YBP Technical Center
134 Godo-cho, Hodogaya-ku
Yokohama, Kanagawa
240 0005
Japan
Tel. +81 45 744 7691
Fax +81 45 744 7696
info@kuka.co.jp

Canada KUKA Robotics Canada Ltd.
6710 Maritz Drive - Unit 4
Mississauga
L5W 0A1
Ontario
Canada
Tel. +1 905 670-8600
Fax +1 905 670-8604
info@kukarobotics.com
www.kuka-robotics.com/canada

Korea	KUKA Robotics Korea Co. Ltd. RIT Center 306, Gyeonggi Technopark 1271-11 Sa 3-dong, Sangnok-gu Ansan City, Gyeonggi Do 426-901 Korea Tel. +82 31 501-1451 Fax +82 31 501-1461 info@kukakorea.com
Malaysia	KUKA Robot Automation Sdn Bhd South East Asia Regional Office No. 24, Jalan TPP 1/10 Taman Industri Puchong 47100 Puchong Selangor Malaysia Tel. +60 3 8061-0613 or -0614 Fax +60 3 8061-7386 info@kuka.com.my
Mexico	KUKA de México S. de R.L. de C.V. Progreso #8 Col. Centro Industrial Puente de Vigas Tlalnepantla de Baz 54020 Estado de México Mexico Tel. +52 55 5203-8407 Fax +52 55 5203-8148 info@kuka.com.mx www.kuka-robotics.com/mexico
Norway	KUKA Sveiseanlegg + Roboter Sentrumsvegen 5 2867 Hov Norway Tel. +47 61 18 91 30 Fax +47 61 18 62 00 info@kuka.no
Austria	KUKA Roboter CEE GmbH Gruberstraße 2-4 4020 Linz Austria Tel. +43 7 32 78 47 52 Fax +43 7 32 79 38 80 office@kuka-roboter.at www.kuka.at

Poland KUKA Roboter Austria GmbH
Spółka z ograniczoną odpowiedzialnością
Oddział w Polsce
Ul. Porcelanowa 10
40-246 Katowice
Poland
Tel. +48 327 30 32 13 or -14
Fax +48 327 30 32 26
ServicePL@kuka-roboter.de

Portugal KUKA Sistemas de Automatización S.A.
Rua do Alto da Guerra n° 50
Armazém 04
2910 011 Setúbal
Portugal
Tel. +351 265 729780
Fax +351 265 729782
kuka@mail.telepac.pt

Russia KUKA Robotics RUS
Werbnaja ul. 8A
107143 Moskau
Russia
Tel. +7 495 781-31-20
Fax +7 495 781-31-19
info@kuka-robotics.ru
www.kuka-robotics.ru

Sweden KUKA Svetsanläggningar + Robotar AB
A. Odhners gata 15
421 30 Västra Frölunda
Sweden
Tel. +46 31 7266-200
Fax +46 31 7266-201
info@kuka.se

Switzerland KUKA Roboter Schweiz AG
Industriestr. 9
5432 Neuenhof
Switzerland
Tel. +41 44 74490-90
Fax +41 44 74490-91
info@kuka-roboter.ch
www.kuka-roboter.ch

Spain	KUKA Robots IBÉRICA, S.A. Pol. Industrial Torrent de la Pastera Carrer del Bages s/n 08800 Vilanova i la Geltrú (Barcelona) Spain Tel. +34 93 8142-353 Fax +34 93 8142-950 Comercial@kuka-e.com www.kuka-e.com
South Africa	Jendamark Automation LTD (Agency) 76a York Road North End 6000 Port Elizabeth South Africa Tel. +27 41 391 4700 Fax +27 41 373 3869 www.jendamark.co.za
Taiwan	KUKA Robot Automation Taiwan Co., Ltd. No. 249 Pujong Road Jungli City, Taoyuan County 320 Taiwan, R. O. C. Tel. +886 3 4331988 Fax +886 3 4331948 info@kuka.com.tw www.kuka.com.tw
Thailand	KUKA Robot Automation (M)SdnBhd Thailand Office c/o Maccall System Co. Ltd. 49/9-10 Soi Kingkaew 30 Kingkaew Road Tt. Rachatheva, A. Bangpli Samutprakarn 10540 Thailand Tel. +66 2 7502737 Fax +66 2 6612355 atika@ji-net.com www.kuka-roboter.de
Czech Republic	KUKA Roboter Austria GmbH Organisation Tschechien und Slowakei Sezemická 2757/2 193 00 Praha Horní Počernice Czech Republic Tel. +420 22 62 12 27 2 Fax +420 22 62 12 27 0 support@kuka.cz

Hungary KUKA Robotics Hungaria Kft.
Fő út 140
2335 Taksony
Hungary
Tel. +36 24 501609
Fax +36 24 477031
info@kuka-robotics.hu

USA KUKA Robotics Corporation
51870 Shelby Parkway
Shelby Township
48315-1787
Michigan
USA
Tel. +1 866 873-5852
Fax +1 866 329-5852
info@kukarobotics.com
www.kukarobotics.com

UK KUKA Automation + Robotics
Hereward Rise
Halesowen
B62 8AN
UK
Tel. +44 121 585-0800
Fax +44 121 585-0900
sales@kuka.co.uk

Index

Numbers

2004/108/EC 85
 2006/42/EC 84
 24 V external power supply 12
 89/336/EEC 85
 95/16/EC 84
 97/23/EC 85

A

Accessories 7, 63
 Additional PE cable 108
 Altitude 54
 Ambient temperature 53
 ANSI/RIA R.15.06-2012 85
 Applied norms and regulations 84
 Automatic mode 81
 Axis range 64
 Axis range limitation 73
 Axis range monitoring 73

B

Basic data 53
 Batteries 7, 13
 Battery discharge protection, reversing 120
 Brake defect 76
 Brake release device 74
 Braking distance 64
 Bus devices 13

C

Cabinet Control Unit 7, 10
 Cabinet cooling 50
 Cabinet Interface Board 10
 Cabinet type 53
 Cable lengths 55, 89
 CCU 10
 CCU functions 10
 CE mark 64
 Charge 13
 CIB 10
 Cleaning work 82
 Configuration of cooling circuit 50
 Connecting cables 7, 63
 Connecting cables, connecting 115
 Connecting the power supply 117
 Connection conditions 89
 Connection panel 7
 Connector pin allocation X11 92
 Connector pin allocation X20 19
 Connector pin allocation X7.1 and X7.2 21
 Connector pin allocation, heavy-duty robot 20
 Control PC 7, 9
 Control PC, functions 10
 Control unit 54
 Controller System Panel 7, 12
 Cooling circuits 50
 Counterbalancing system 82
 CSP 12

CSP overview 12
 Customer equipment 51

D

Danger zone 65
 Data cables 16, 116
 Declaration of conformity 64
 Declaration of incorporation 63, 64
 Decommissioning 83
 Dimensions of boreholes 59
 Dimensions of robot controller 56
 Dimensions, smartPAD holder 58
 Disposal 83
 Drive controller 7
 Drive power supply 7
 Dynamic testing 98

E

EC declaration of conformity 64
 Electromagnetic compatibility (EMC) 85
 Electromagnetic compatibility, EMC 87
 EMC Directive 64, 85
 EMERGENCY STOP device 70, 71, 75
 EMERGENCY STOP device on the robot controller 96
 EMERGENCY STOP device, X11 96
 EMERGENCY STOP, external 71, 78
 EMERGENCY STOP, local 78
 EMERGENCY STOP, series connection 96
 EMERGENCY STOP, star configuration 97
 EN 60204-1 + A1 85
 EN 61000-6-2 85
 EN 61000-6-4 + A1 85
 EN 614-1 85
 EN ISO 10218-1 85
 EN ISO 12100 85
 EN ISO 13849-1 85
 EN ISO 13849-2 85
 EN ISO 13850 85
 Enabling device 71, 75
 Enabling device, external 72
 Enabling switches 71, 103
 Environmental conditions 53
 Equipotential bonding 53, 89
 EtherCAT connection on the CIB 107
 Exchanging devices 109, 121
 Exhaustive discharge of battery 54
 External axes 63, 66
 External axes 1 and 2 21
 External axis 1 21
 External axis X7.1 17
 External axis X7.2 17
 External enabling switch, function 96
 External voltage 55, 90

F

Fans 7
 Faults 76

Filter mats 50
 Floor mounting 59
 Full-load current 53, 89
 Function test 78
 Fuse elements 7

G

General safety measures 76
 Guard interlock 69

H

Hazardous substances 83
 Humidity class 54

I

Industrial robot 7, 63
 Infeed 16
 Installation conditions 87
 Installing the robot controller 115
 Intended use 63
 Interfaces 16
 Interfaces, control PC 45
 Interfaces, motherboard D2608-K 46
 Interfaces, motherboard D3076-K 47
 Interfaces, motherboard D3236-K 48

J

Jog mode 72, 75

K

KCB devices 13
 KEB configuration variants 14
 KEB devices 14
 KPP 8
 KSB configuration variants 14
 KSB devices 14
 KSP 9
 KUKA Customer Support 125
 KUKA Power Pack 7, 8
 KUKA Servo Pack 7, 9
 KUKA smartPAD 54, 65
 KUKA smartPAD cable 16
 KUKA smartPAD holder (optional) 49
 KUKA smartPAD holder, fastening 90

L

Labeling 74
 Liability 63
 Lifting frame 111
 Linear unit 63
 Low Voltage Directive 64
 Low-voltage power supply unit 7, 12

M

Machine data 78
 Machinery Directive 64, 84
 Mains filter 13
 Mains frequency 53, 89
 Mains-side fusing 53, 89
 Maintenance 82
 Manipulator 7, 63, 65

Manual mode 80
 Mechanical axis range limitation 73
 Mechanical end stops 73
 Minimum clearances, robot controller 57
 Mode selection 68, 69
 Monitoring, velocity 72
 Motherboard D2608-K 46
 Motherboard D3076-K 47, 48
 Motherboard D3236-K 48, 49
 Motherboards 45
 Motor cables 16
 Motor connector X20 19
 Motor connector Xxx 17
 Multiple connector X81 28

O

Operator 67
 Operator safety 68, 69, 75
 Operator safety acknowledgement 109
 Options 7, 63
 Overload 76
 Overview of robot controller 7
 Overview of the industrial robot 7

P

Palletizing robot, connector pin allocation X7.1 27
 Palletizing robot, connector pin allocation X7.1 and X7.2 28
 Palletizing robot, external axes 1 and 2 28
 Palletizing robot, external axis 1 27
 Panic position 71
 PE cables 16
 PE equipotential bonding 107
 PE equipotential bonding, connecting 117
 PELV power supply unit 55, 90
 Performance level 109
 Performance Level 68
 Peripheral cables 16
 Permissible tolerance of rated voltage 53, 89
 Personnel 66
 PFH values 109
 PL 109
 Planning 87
 Plant integrator 66
 Plates and labels 59
 PMB 10
 Positioner 63
 Power cable 16
 Power failure 13
 Power Management Board 10
 Power supply connection on the main switch 91
 Power supply connection, technical data 53, 89
 Power supply with battery backup 10
 Power supply without battery backup 11
 Power switched off 13
 Pressure Equipment Directive 83, 85
 Preventive maintenance work 82
 Product description 7
 Protection classification 53
 Protective equipment 72

R

Rated supply voltage 53, 89
 RDC functions 11
 Reaction distance 64
 Recommissioning 77, 115
 Release device 74
 Repair 82
 Resolver cable, length difference 55, 90
 Resolver Digital Converter 11
 Robot controller 7, 63

S

Safe operational stop 65, 72
 Safeguards, external 75
 Safely isolated 55, 90
 SafeOperation via Ethernet safety interface 104
 Safety 63
 Safety controller 69
 Safety functions 68, 75
 Safety functions, Ethernet safety interface 100
 Safety functions, overview 68
 Safety Interface Board 7, 11, 55
 Safety interface X11, description 91
 Safety of machinery 85
 Safety options 65
 Safety STOP 0 65
 Safety STOP 1 65
 Safety STOP 2 65
 Safety STOP 0 65
 Safety STOP 1 65
 Safety STOP 2 65
 Safety stop, external 72
 Safety zone 65, 67
 Safety, general 63
 Service life 65
 Service, KUKA Roboter 125
 SIB 11, 55
 SIB description 11
 SIB functions 11
 SIB inputs 56
 SIB outputs 55
 SIB wiring 91
 SIB, safe input 98
 SIB, safe output 98
 Signal "Peri enabled" 94
 Simulation 81
 Single connectors X7.1 to X7.4 28
 Single connectors X7.1 to X7.8 36
 Single point of control 83
 Slot assignment, motherboard D2608-K 46
 Slot assignment, motherboard D3076-K 48
 Slot assignment, motherboard D3236 49
 smartPAD 65, 76
 smartPAD cable extensions 55, 89
 smartPAD holder, fastening 116
 smartPAD, plugging in 116
 Software 7, 63
 Software limit switches 73, 75
 Sound level 53
 Space for integration of customer options 51
 SPOC 83

Start-up 77, 115
 Start-up mode 79, 121
 STOP 0 64, 66
 STOP 1 64, 66
 STOP 2 64, 66
 Stop category 0 66
 Stop category 1 66
 Stop category 2 66
 Stop reactions 67
 Stopping distance 64
 Storage 83
 Support request 125
 Swing range for cabinet door 58
 Switching on the robot controller 122
 System configuration, modifying 109, 121
 System integrator 64, 66, 67

T

T1 66
 T2 66
 Teach pendant 7, 63
 Technical data 53
 Terms used, safety 64
 Test output A 93, 95
 Test output B 93, 95
 Transient limiter, description 50
 Transportation 77, 111
 Transportation, fork lift truck 112
 Transportation, lifting tackle 111
 Transportation, pallet truck 112
 Transportation, set of rollers 113
 Turn-tilt table 63

U

Use, contrary to intended use 63
 Use, improper 63
 User 65, 66

V

Velocity monitoring 72
 Vibration resistance 54

W

Weight 53
 Working range limitation 73
 Workspace 64, 67

X

X11, configuring 121
 X11, contact diagram 97
 X19 connector pin allocation 117
 X20, palletizing robot, 4 axes 23
 X20, palletizing robot, 5 axes 25
 X20.1 and X20.4, palletizing robot, 5 axes 24
 X20.1 connector pin allocation 20
 X20.4 connector pin allocation 20
 X21 connector pin allocation 116
 X7.1 to X7.3, 3 axes 37
 X7.1 to X7.4, 4 axes 38
 X7.1 to X7.5, 5 axes 39
 X7.1 to X7.6, 6 axes 40

X7.1 to X7.7, 7 axes 42
X7.1 to X7.8, 8 axes 44
X7.1, connector pin allocation 21
X8, palletizing robot, 4 axes 22
X81, 3 axes 29
X81, 4 axes 26, 30
X81, X7.1 and X7.2, 6 axes 32
X81, X7.1 to X7.3, 7 axes 33
X81, X7.1 to X7.4, 8 axes 34
X81, X7.1, 5 axes 31
X82, 8 axes 27

