

TSX ESY 007 Module Installation Manual

October 2005 eng

35010594 02



Telemecanique

Table of Contents



Safety Information	7
About the Book	9
Part I The TSX ESY 007 Module	11
At a Glance	11
Chapter 1 General Presentation of the TSX ESY 007 Module	13
At a glance	13
At a Glance	14
Note concerning the input/output extension bus	15
Panorama of the Series 7 products in the Schneider catalog	16
Main components - Presentation	17
Figure showing sample topology of input/output extension bus	20
Main features of input/output extension bus	21
Part II Hardware Installation of TSX ESY 007 Input/Output Extension Bus Interface Coupler	23
At a Glance	23
Chapter 2 Input/Output Extension Bus Coupler Interface: TSX ESY 007	25
At a Glance	25
2.1 Description of the TSX ESY CM 007 Module	26
At a Glance	26
Physical presentation	27
Mounting/Installation	28
Connections	30
LED module status indicators	32
Special LED indicators of the TSX ESY 007 Module	33
Technical Features	34
User safety	36
2.2 Use of the TSX ESY 007 Module for System Upgrade	37
At a Glance	37

At a Glance	38
Installation	39
Recovering racks 0 to 3	42
For double format racks	44
LES120/LFS120 Remote Entrance Links	45
Methodology for Upgrading the PL7-3 PLC Program	47
2.3 Input/Output Extension Bus Diagnostics	50
I/O extension bus diagnostics - Presentation	50
2.4 Operating Modes of the TSX ESY CM 007 Module	51
TSX ESY 007 Module Operating Modes	51
2.5 Precautions for Use	53
Double rack addressing	53
Part III Software Installation for the TSX ESY 007 Module	55
At a Glance	55
Chapter 3 TSX ESY 007 Module Software Installation - Principles	57
At a Glance	57
Installation of the I/O extension bus - Presentation	58
TSX ESY 007 Module Architecture	60
Structure of a Series 7 module	61
Addressing Language Objects Associated with Series 7 Devices On the I/O Extension Bus	63
Use of EF SEND_REQ for Handling Series 7 Modules with Extended and Message Registers	65
Chapter 4 Configuring the TSX ESY 007 Module	75
At a Glance	75
Declaring a TSX ESY 007 Module in the PLC rack	76
Description of the Configuration Screen of a TSX ESY 007 Module	77
Declaring a Series 7 Device to the TSX ESY 007 Module	79
Displaying the I/O Extension Bus in the Project Browser	82
Modifying the software configuration of a TSX ESY 007 Module	84
Accessing the Description of a Series 7 Module	85
Accessing the Description of a Series 7 Rack	86
Accessing the Description of a Series 7 Module	87
Modifying General Parameters of a Series 7 Rack	88
Chapter 5 Debugging the TSX ESY 007 Module	89
At a Glance	89
The debug function - Presentation	90
Description of the Debug Screen of a TSX ESY 007 Module	91
Accessing TSX ESY 007 Module Diagnostics and Channel Diagnostics Functions	93
Viewing Status of Series 7 Racks and Modules	95
Accessing the Forcing/Unforcing Discrete Channels Function	97

	Modifying the Value of an Analog Channel	98
Chapter 6	Performance of the TSX ESY 007 Module	99
	Performance of the TSX ESY 007 Module	99
Chapter 7	Language Objects of the TSX ESY 007 Module	101
	At a Glance	101
7.1	Language Objects and IODDT of TSX ESY 007 Module Communications . . .	102
	At a Glance	102
	TSX ESY 007 Module Language Objects - Presentation	103
	Implicit Exchange Language Objects Associated With an Application-specific Function	104
	Explicit Language Objects Associated With an Application-specific Function	105
	Management of the exchange and report with explicit objects	107
7.2	General Language Objects and IODDT for All Communication Protocols . . .	110
	At a Glance	110
	Implicit Exchange Objects of the T_COM_STS_GEN-type IODDT - Details . .	111
	T_COM_STS_GEN-type IODDT Explicit Exchange Objects - Details	112
7.3	Language Objects and IODDT Associated with the TSX ESY 007 Module . . .	114
	At a Glance	114
	Details of the implicit exchange objects of the IODDT of the T_COM_ESY type.	115
	Details of the T_COM_ESY-type IODDT Explicit Exchange Objects	119
	Implicit Exchange Objects of the TSX ESY 007 Module - Details.	120
	Configuration Objects for the TSX ESY 007 Module - Details	122
7.4	The T_GEN_MOD IODDT Applicable to All Modules	123
	Details of the Language Objects of the IODDT of Type T_GEN_MOD.	123
Index	125

Safety Information

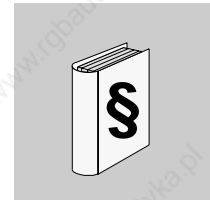

Safety Instructions

NOTICE

Read these instructions carefully and examine the materials so you become familiar with the device before attempting to install, operate or maintain it. You may see the following special messages in this documentation or on the device. The purpose of these messages is to alert you to potential risks or bring to your attention information to clarify or simplify a procedure.



The appearance of this symbol on a Danger or Warning safety panel indicates an electrical risk. Failure to follow instructions could result in bodily harm.



This is the safety warning symbol. It alerts you of a risk of bodily injury. You must scrupulously follow all safety instructions associated with this symbol to avoid bodily harm or place your life in danger.



DANGER

DANGER indicates an imminent dangerous situation that, if not avoided, **will result in** death, grave injury or material damage.



WARNING

WARNING indicates a potentially dangerous situation that, if not avoided, **could result in** death, grave injury or material damage.



ATTENTION indicates a potentially dangerous situation that, if not avoided, **may result in** injury or material damage.

Important Notice

All pertinent state, regional, and local safety regulations must be observed when installing and using this product. For reasons of safety and to ensure compliance with documented system data, only the manufacturer should perform repairs to components. When controllers are used for applications with technical safety requirements, please follow the relevant instructions. Schneider Electric assumes no liability for consequences that may result from the use of this documentation. This document should not serve as a guide for persons who do not have in-depth knowledge of this product.

About the Book

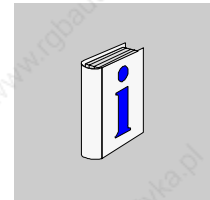

At a Glance

Document Scope This manual describes how to install hardware and software for the TSX ESY 007 Module.

Validity Note The data and illustrations found in this documentation are not binding. We reserve the right to modify our products in line with our policy of continuous product development.

The information in this document is subject to change without notice and should not be construed as a commitment by Schneider Electric.

Product Related Warnings Schneider Electric assumes no responsibility for any errors that may appear in this document. If you have any suggestions for improvements or amendments or have found errors in this publication, please notify us.

No part of this document may be reproduced in any form or by any means, electronic or mechanical, including photocopying, without express written permission of Schneider Electric.

All pertinent state, regional, and local safety regulations must be observed when installing and using this product.

For reasons of safety and to ensure compliance with documented system data, only the manufacturer should perform repairs to components.

When controllers are used for applications with technical safety requirements, please follow the relevant instructions.

Failure to observe this product-related warning can result in injury or equipment damage.

User Comments We welcome your comments about this document. You can reach us by e-mail at techpub@schneider-electric.com

The TSX ESY 007 Module



At a Glance

Subject of this Section

This section presents the TSX ESY 007 Module on Premium and Atrium PLCs.

What's in this Part?

This part contains the following chapters:

Chapter	Chapter Name	Page
1	General Presentation of the TSX ESY 007 Module	13

General Presentation of the TSX ESY 007 Module

1

At a glance

Object of this chapter

This chapter provides general information about the TSX ESY 007 Module.

What's in this Chapter?

This chapter contains the following topics:

Topic	Page
At a Glance	14
Note concerning the input/output extension bus	15
Panorama of the Series 7 products in the Schneider catalog	16
Main components - Presentation	17
Figure showing sample topology of input/output extension bus	20
Main features of input/output extension bus	21

At a Glance

TSX ESY 007 Module

The TSX ESY 007 Module acts as gateway for retrieval of I/O of TSX Series 7 PLC racks to a Premium PLC, via the I/O extension bus. It is intended for upgrading automated systems equipped with programmable TSX Series 7 PLCs 40 (47, 67, 87 and 107 in version V2, V3, V4 or V5).

It is mounted in a Premium rack equipped with a Premium UNITY V2.00 minimum processor.

The configuration of this coupler in UNITY Pro is protected by access rights. These rights may only be used by Schneider Services Industries entities in France, and abroad by Schneider Services entities or otherwise by its representatives.

Recovery of the PL7-3 program of the system to be upgraded is possible through the successive use of PL7-3/PL7 Pro and PL7 Pro/UNITY Pro converters.

Note concerning the input/output extension bus

Overview

The input/output bus is a serial bus that enables control of TSX Series 7 racks. It allows routing of "All Or None", "Analog" and "Message" type information between bus master and Series 7 modules by intermediary of LES20 slave modules.

The input/output bus is made up of three major base components:

- a bus master,
- slaves (input/output entrance link modules),
- TSX Series 7 I/O modules.

Note: For additional information on the input/output bus and the features of Series 7 devices, see the Series 7 documentation.

Panorama of the Series 7 products in the Schneider catalog

Overview

Complete list of Series 7 products in the Schneider catalog supported by the **TSX ESY 007 Module**:

Discrete I	Discrete O	I ANA	O ANA	Other
TSX DET 4 66	TSX DST 4 17	TSX AEM 4 11	TSX ADT 2 01	TSX AXT 2 00
TSX DET 8 02	TSX DST 8 04	TSX AEM 4 12	TSX ADT 2 02	TSX CCM 1 00
TSX DET 8 03	TSX DST 8 05	TSX AEM 4 13	TSX ADT 2 03	TSX CTM 1 00
TSX DET 8 05	TSX DST 8 17	TSX AEM 8 11	TSX AST 2 00	TSX DTM 1 00
TSX DET 8 12	TSX DST 8 35	TSX AEM 8 21	TSX ASR 2 00	TSX DMR 16 52
TSX DET 8 13	TSX DST 8 82	TSX AEM 12 12	TSX ASR 4 01	TSX DEM 24xx
TSX DET 8 14	TSX DST 16 04	TSX AEM 16 01	TSX ASR 4 02	
TSX DET 8 24	TSX DST 16 12	TSX AEM 16 02	TSX ASR 4 03	
TSX DET 16 03	TSX DST 16 32	TSX AEM 16 13	TSX ASR 8 00	
TSX DET 16 04	TSX DST 16 33			
TSX DET 16 12	TSX DST 16 34			
TSX DET 16 13	TSX DST 16 35			
TSX DET 16 33	TSX DST 16 82			
TSX DET 32 12	TSX DST 24 72			
TSX DET 32 32	TSX DST 24 82			
TSX DET 32 42	TSX DST 32 92			
TSX DET 32 52				

List of products in the Schneider catalog not supported by the **TSX ESY 007 Module**:

- TSX AXM 171/1711 axial command couplers,
- TSX AXM 162/172/182 axial command couplers,
- TSX AXM 292/492 axial command couplers,
- TSX SCM XXX, TSX MPT 10, TSX ETH XXX, TSX FMP XXX, TSX IBS XXX, TSX MAP XXX communication couplers,
- TSX PCM37(MMX), PCM00, TSX LSM 200, TSXLSM240 (warm-standby), TSX ADA200, TSX ETH 200, TSY MSM XXX couplers,
- couplers specifically designed for target clients.

Main components - Presentation

The cable

It transmits data: It may be one of the following:

- a TSX CBC xxx cable for a local entrance link,
- a TSX CBD xxx 100/140 diameter fiber optical cable for an optical entrance link,
- or a TSX CBC xxx cable for an electrical entrance link,

TSX LES20 slave modules

Installed in first position in the TSX Series 7 tray, they dialog with the TSX ESY 007 module and control the TSX Series 7 present on their main and direct extension (optional) racks.

Illustration:

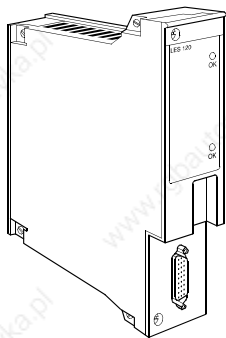

Note: In the case of electrical or optical entrance links, the slave couplers used will be TSX LES 200 or TSX LFS 200 modules.

The terminal block connectors

They provide chaining between the cables and the TSX LES20 slave modules. They allow encoding of the TSX Series 7 rack address on the LES20 bus.

On the TSX ESY 007 side, mainly the TSX LES 64, 65, 74 and 75 references will be used.

On the Series 7 rack side, mainly the TSX LES 61, 62, 70 and 71 references will be used.

Illustration:

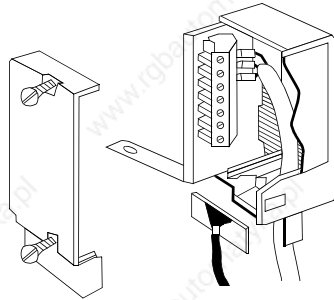

The Bus master

The I/O bus master manages all data exchange on the I/O extension bus.

It is possible to integrate the TSX ESY 007 Module in a Premium/Atrium PLC station to manage the I/O extension bus.

**Premium
Illustration**

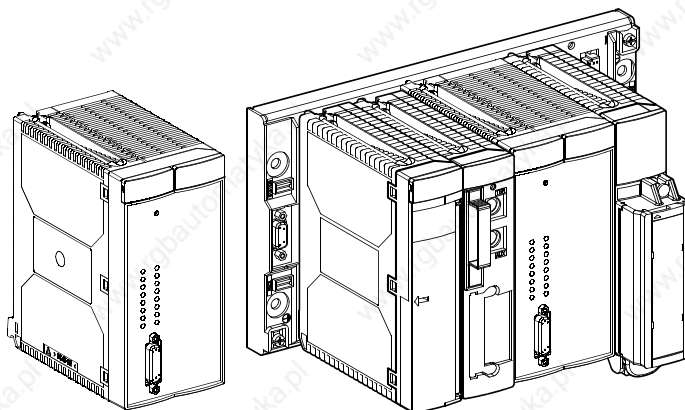

TSX ESY 007

Premium Station

**Atrium
Illustration:**

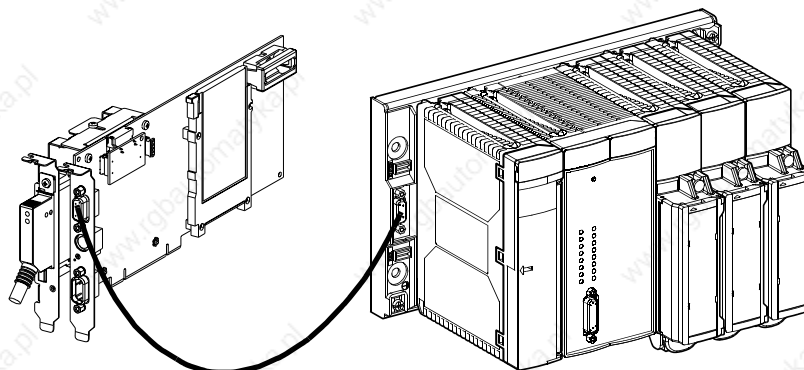

Atrium Station

Figure showing sample topology of input/output extension bus

Illustration

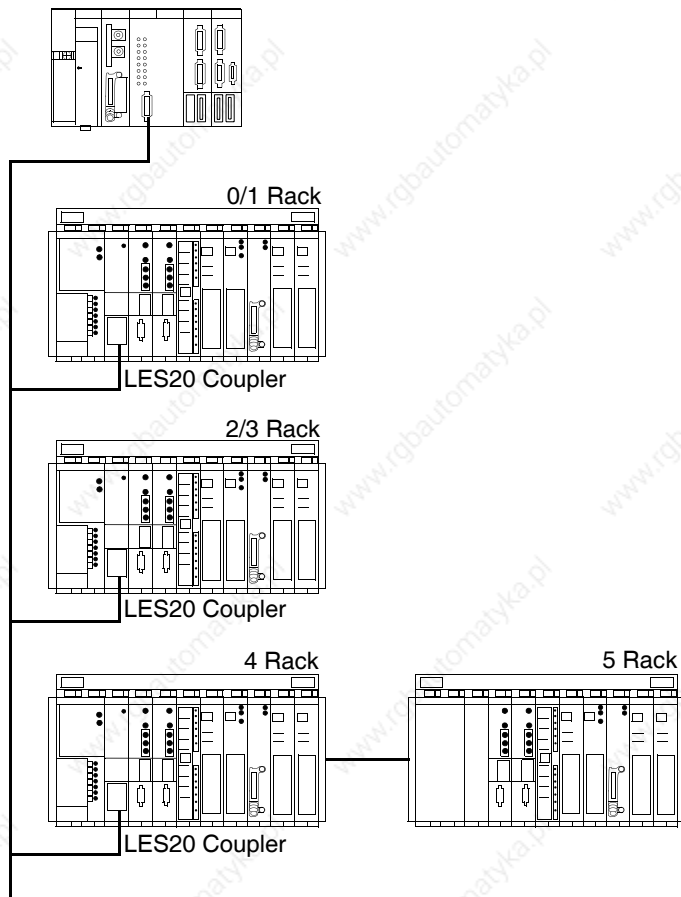

Main features of input/output extension bus

General Points The I/O extension bus is a system in which interchange management is ensured by a single master that calls each LES20 slave module.

The serial communication frame sends the following services:

- read 4/8/16 bits Discrete,
- write 4/8/16 bits Discrete,
- read 8 words ANA,
- write 8 words ANA,
- message read in module,
- message write in module,
- read module status,
- read LES20 module status,
- LES20 module command.

The I/O Serial Extension Bus is a type RS422 Bus with a speed of 2 Mbits/s on TSX 47/67/87/107 and 4 Mbits/s on some TSX 107.

TSX LES20 slave addressing Each LES 20 module must have an even address between 0 and 14.
The address is encoded using switches in the TSX LES 6x/7x terminal blocks.
For electrical or optical entrance links, addresses are encoded directly on the LES200 or LFS200 modules.

Maximum number of inputs/outputs An I/O extension bus may handle a maximum of 16 8-slot racks.
The maximum number of I/O is 2048 E Discrete, 2048 S Discrete, 256 E ANA and 256 S ANA.

I/O Bus Extension Cable The I/O extension cable depends on the type of cable entrance link reference: TSX CBC xxx, TSX CBD xxx or TSX CB xxx.
For additional information on its features, see the TSX Series 7 documentation.

I/O extension bus layout and maximum length The I/O extension bus layout is defined by the number of racks to connect.
Based on the type of entrance link (local, electrical, optical), the total length of all bus branches must not exceed 30, 500, or 2000 meters.

I/O extension bus scan time

This is the scan time between output transmit to Series 7 modules by the TSX ESY 007 module and recovery of Series 7 module inputs.

The TSX ESY 007 module transmits or requests variable length information to each Series 7 module via the bus based on the type of module (Track No., Discrete/ANA, Messaging). The I/O extension bus scan time depends on the number and type of Series 7 module to drive on the bus.

With a complete representative configuration, this time will be maximum of 90 ms.

Reliability, flexibility

The transmission procedure used guarantees reliable operation. The master monitors the activity of the LES20 slave modules and the data sent.

It detects transmission errors as well as Series 7 and LES20 slave module failures and sends data to the PLC.

Hardware Installation of TSX ESY 007 Input/Output Extension Bus Interface Coupler

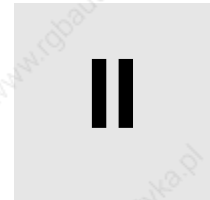

At a Glance

Subject of this Section

This section presents the hardware installation of the TSX ESY 007 Module interface coupler, I/O extension bus master.

What's in this Part?

This part contains the following chapters:

Chapter	Chapter Name	Page
2	Input/Output Extension Bus Coupler Interface: TSX ESY 007	25

Input/Output Extension Bus Coupler Interface: TSX ESY 007

2

At a Glance

Subject of this Chapter

This chapter covers hardware installation of the **TSX ESY 007** interface coupler, I/O extension bus master from a Premium/Atrium PLC.

What's in this Chapter?

This chapter contains the following sections:

Section	Topic	Page
2.1	Description of the TSX ESY CM 007 Module	26
2.2	Use of the TSX ESY 007 Module for System Upgrade	37
2.3	Input/Output Extension Bus Diagnostics	50
2.4	Operating Modes of the TSX ESY CM 007 Module	51
2.5	Precautions for Use	53

2.1 Description of the TSX ESY CM 007 Module

At a Glance

Subject of this Section

This section covers hardware installation and features of the TSX ESY 007 Module.

What's in this Section?

This section contains the following topics:

Topic	Page
Physical presentation	27
Mounting/Installation	28
Connections	30
LED module status indicators	32
Special LED indicators of the TSX ESY 007 Module	33
Technical Features	34
User safety	36

Physical presentation

Description

The TSX ESY 007 Module presents a double slot format.

Illustration:

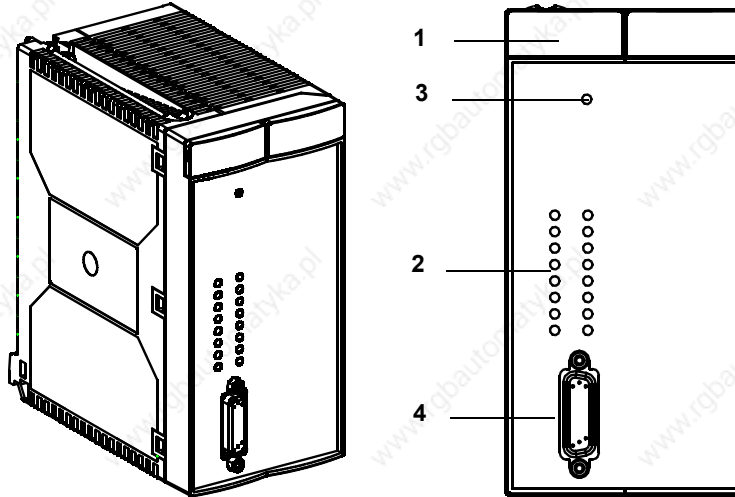

The following table describes the diagrams according to address:

Number	Description
1	Status indicator panel with 4 indicator lights for display of module operation modes: <ul style="list-style-type: none"> ● RUN indicator (green): on, signals normal operation of module, ● BAT indicator (red): on, signals module fault, ● I/O indicator (red): on, signals input/output fault on I/O extension bus.
2	Status indicator panel with 16 indicator lights (0 to F) for diagnostics of racks on the I/O extension bus.
3	Pencil point button for module reset.
4	SUB D 26-pin high-density connector for connection to the I/O extension bus. Receives the TSX LES 64/65/74/75 terminal block connectors.

Mounting/Installation

Overview

The TSX ESY 007 Module mounts in any position on a Premium TSX RKY rack on the main segment of bus X, except for positions dedicated for processor and power supply. The processor is a Premium UNITY processor version V2.00 minimum.

	WARNING
	Not allowed in an extension rack This module cannot operate in an extension rack (distance > 100m), and absolutely must be assembled in a main segment rack of the X bus. Failure to follow this instruction can result in death, serious injury, or equipment damage.

The mounting and dismounting procedure (See Premium and Atrium UNITY Pro Manual, Discrete input/output modules, Installation of input/output modules) is identical to the mounting and dismounting procedure of other modules.

Installation and removal of this module is performed using a flat or cross-slot screwdriver.

These operations can be performed whether the power is on or off, with no adverse effect on the module or the rack holding it.

Note: Mounting and dismounting of the module may be performed with PLC power on and I/O extension bus connected.

Number of modules per station

The maximum number of TSX ESY 007 modules that may be installed in a Premium/Atrium station depends on the features of the processor used. The coupler is installed as a field bus and not as an application track.

Processor reference	Authorized TSX ESY CM 007 Module number
TSX P57 0244	1
TSX P57 104	2
TSX P57 154	2
TSX P57 1634	2
TSX P57 204	4
TSX P57 254	4
TSX P57 2634	4
TSX P57 304	8
TSX P57 354	8
TSX P57 3634	8
TSX P57 454	8
TSX P57 4634	8
TSX P57 554	8
TSX P57 5634	8
TSX PCI57 204	4
TSX PCI57 354	7

It is recommended to choose at least a TSX P57 3xxx/4xxx/5xxx processor to ensure proper functioning of the TSX ESY 007 Module.

For further information, refer to the following documents:

Number of field bus connections managed

- Premium (See UNITY Pro Premium and Atrium User Manual, Processors, racks and power supply, TSX 57 Processor Catalogue)
- Atrium (See UNITY Pro Premium and Atrium Manual, Processors, racks and power supply, Atrium Catalog)

Maximum number of input/outputs managed by the TSX ESY 007 Module

The TSX ESY 007 Module may control a maximum of 16 8-slot racks.

The maximum number of I/O that it can manage is 2048 E Discrete, 2048 S Discrete, 256 E ANA and 256 S ANA.

The Series 7 Discrete, analog and working tracks controlled by the TSX ESY 007 Module are not included in the calculation of the maximum number of Discrete, analog or application tracks of a Premium/Atrium processor.

Connections

Connecting to the X bus

The module is automatically connected to the X bus when it is inserted into the receiving rack. If the module is placed in the base rack, its connection with the CPU and the power supply module is assumed. When this is not the case, the module is powered by the power supply of the rack on which is positioned and the connection with the processor is assured by connection of X bus to all racks.

Connecting to the LES20 bus

The I/O extension bus connection procedure is not chronological between equipment (Bus Master or TSX 7 Rack), but the overall operation cannot be guaranteed during this phase of installation.

The I/O extension bus does not require a specific ground connection, on the other hand Power Supply and PLC equipment must follow standard installation requirements. It is recommended not to place the I/O extension bus next to high-energy cables.

The medium connection system is designed to connect by means of the TSX CBC xxx cable. Whatever the layout, the sum of cable lengths of the same I/O extension bus should not exceed 30 meters. Moreover, an electrical or optical entrance link should be used.

I/O Extension Bus Cables

The I/O extension bus cables carry signals to TSX 7 racks and modules. The features of this cable are available in the documentation for I/O configuration installation on TSX Series 7 modules.

Recommended Cable: TSX CBC xxx.

Cable Routing

The I/O extension bus cables and high-energy power cables must be in separate channels, protected by a metallic divider.

When routed together with control cables, it is imperative to make control link connections according to generally accepted practices.

Connector plug

The TSX LES 64/65/74/75 terminal blocks allow connection of the module to the I/O extension bus. These terminal blocks are connected to the I/O extension bus cable and assembled by the user according to steps described later.

In most cases, you can use the existing TSX LES 64/65/74/75 connector from the existing installation that was used to connect the TSX 7 processor to the I/O extension bus.

In all cases, a TSX LES 64 or 65 terminal block will be used when the TSX ESY 007 module drives Series 7 racks as local entrance link and a TSX LES 74 or 75 terminal block is used when it drives electrical or optical entrance link racks.

Illustration:

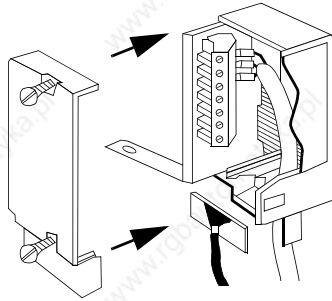
**Connecting the module to the bus.**

To connect the module to the bus, follow the procedure below (if no existing terminal block is available):

Step	Action
1	Preparing the TSX LES 64/65/74/75 connection box: <ul style="list-style-type: none"> ● open the cover, ● connect one end of the TSX CBC chaining cable to the connecting connector (Cf. TSX Series 7 documentation), ● close the cover.
2	Position the box on the 26-pin connector of the TSX ESY 007 Module.
3	Connect the ground wire of the box to the ground lug of the case. If the ground wire is too short to be connected to the case, replace it with a longer wire while respecting the length/width in order to avoid "Pigtail" phenomena.

LED module status indicators

General Points 4 LED indicators located on the module, RUN, ERR, TER, I/O provide information on module operation (LED off, blinking or on).

LED indicators	On	Flashing	Off
RUN (green)	Module operating normally	Module self-tests (1) or in standby for configuration	Module failure, or module power off
ERR (red)	Serious internal fault, module failure	Module self-tests (1) or fault: system OK however: <ul style="list-style-type: none">● application fault or,● I/O extension bus cables fault	No internal fault
COM (yellow)	-	Module self-tests (1)	
I/O (red)	Default inputs/outputs	Module self-tests (1)	Module operating normally

(1) simultaneous flashing of all 4 LED indicators during self-tests on module power-up.

Special LED indicators of the TSX ESY 007 Module

Overview

16 LED indicators allow visual inspection of operation status of TSX 7 extension racks controlled by the TSX ESY 007 Module.

LED appearance:

Rack	
0	1
2	3
4	5
6	7
8	9
A	B
C	D
Of	F

LED status:

LED status:	Meaning
LED green	Corresponding rack configured in the UNITY Pro Premium application and operating normally
LED flashing green	Corresponding rack configured in the UNITY Pro Premium application and by default
LED off	Corresponding rack not configured in the UNITY Pro Premium application

Technical Features

LES20 bus

Feature	Value
Maximum I/O extension bus scan time	50 ms
Rack number on I/O extension bus	16
Maximum length of I/O extension bus (without optical or electrical link)	30 meters
Maximum number of inputs/outputs	2048 I/O Discrete + 256 I/O ANA

TSX ESY 007 Module

Feature	Value
Programming the TSX ESY 007 Module	Unity Pro
Response time for 128 16-channel discrete modules in the MAST task (1)	75 ms typical 85 ms maximum
Calculation of I/O extension bus polling time for n modules (normal operation)	0.192 ms x Number of 4-channel discrete modules + 0.228 ms x Number of 8-channel discrete modules + 0.300 ms x Number of 16-channel discrete modules + 1.900 ms x Number of ANA/ Analog modules + 7.3 ms
Current consumed by 5 V PLC	75 mA typical/100 mA maximum
Power dissipation	0.5 W maximum
Level of protection	IP20
Operating temperature	0 to 60 degrees Celsius
Standards and conditions of service	In conformity with those of Premium PLCs

(1) Logical response time = time between one I/O extension bus input activated on the bus, processed in the PLC application and applied on an I/O extension bus output.

Note:

The PLC scan time must be adjusted on the periodic mode and not on the scan mode and a task period calculated according to the following formula:
 "Scan time task X \geq Estimated scan time of theoretical LES20 X bus task + Execution time of programmed task X".
 Program execution time for a given task may be calculated from %SW30 to 35. For details on I/O extension bus scan time, see in Chapter 6. In debug phase, information on the real scan time of the I/O extension bus (current and maximum) is provided to allow more exact adjustment of the PLC scan time.
 If the PLC scan time is less than the LES20 bus scan time or if the task is in scan mode, synchronization of cycles is not guaranteed. In cases such as this, the operation mode will be asynchronous between the PLC scan and the LES20 bus scan.
 If the PLC program uses messaging features for the TSX Series 7 modules, you must increase the configured cycle type to enable the TSX ESY 007 module to manage the messaging requests.

User safety

Overview

To ensure user safety, you must:

- Connect the PLC ground wire to the ground.
- For a PLC connected to an AC networks, place a differential circuit breaker upstream in the network to interrupt the PLC power supply in the event that a leak with the ground is detected.
- For a PLC connected to a DC power supply, to ensure that the power supply placed upstream of the PLC is TBTS.
- To use certified Schneider Electric products on the bus.

On account of its technology and connection, the TSX ESY 007 Module only receives 5 VDC and its zero electrical volt is connected to the ground of the PLC.

2.2 Use of the TSX ESY 007 Module for System Upgrade

At a Glance

Subject of this Section

This section covers installation of the TSX ESY 007 Module for a system upgrade.

What's in this Section?

This section contains the following topics:

Topic	Page
At a Glance	38
Installation	39
Recovering racks 0 to 3	42
For double format racks	44
LES120/LFS120 Remote Entrance Links	45
Methodology for Upgrading the PL7-3 PLC Program	47

At a Glance

Overview

The TSX ESY 007 Module is a Premium X bus module for revamping automated systems equipped with TSX Series 7 programmable PLCs. It allows creation of a gateway between a Premium PLC and the I/O serial extension bus of TSX Series 7 PLCs. It offers the possibility of replacing the processor of a TSX Series 7 system by a TSX Premium processor and keeping the base racks and extension racks of the TSC Series 7. It thus allows recovery of all in a TSX Series 7 by connecting and controlling the LES20 series bus.

It thus offers a solution to modernize TSX Series 7 systems and benefit from Premium / UNITY technology without having to redo all the cabling of the I/O modules.

Installation

A TSX Series 7 PLC, versions V3, V4 and V5, is composed of 2 main racks numbered 0/1 and 2/3 and 12 extension racks numbered from 4 to 15.

The two main racks are linked by a parallel bus when the extension racks are linked to the CPU by a serial bus. Each direct extension is linked to its main extension rack by a parallel bus.

The diagram is the following:

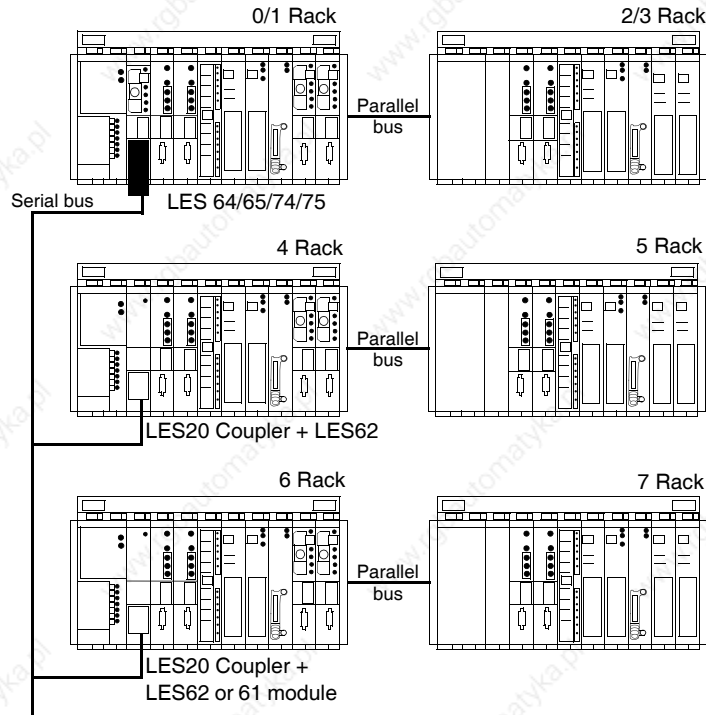

The LES20 Series 7 module manages data exchange with the TSX7 CPU. It transforms the I/O data that it receives via serial bus into data on the parallel bus of the extension racks. Through a TSX LES 61/62 connection box, the LES20 Series 7 module has an extension rack address representing the address of the extension rack it manages.

Special architecture

- 2/3 rack managed by a LES20 coupler.
In certain configurations, the 2/3 rack is not managed as a direct extension of the base rack by a parallel bus, but is managed as a serial bus by a LES20 coupler. When this is the case, the 2/3 rack may also be kept without any problem during upgrade.
- Double format rack
In version V2, 67/30, 87/10 and 87/20 processors and in version V3, 87/30 processors are positioned in the double format racks. The lower part has a complete bus, and the upper part has a simplified bus. For 87/10 and 87/20 processors, positions 00 and 10 may be occupied by a memory extension card (TSXMEM4x). To upgrade these configurations, a LES20 coupler should be installed in place of the processor in the lower part of the rack.
- Electrical (LES120) and optical (LFS120) remote extension
Remote input/output extensions allow entrance linkage at great distances from base controller cases capable of supporting modules of any kind. Two technologies may be used: entrance linkage by fiber optical bus (maximum distance of link 2000 meters) or entrance linkage by electrical bus (maximum distance 500 meters). Remote I/O extensions are composed of cases that have integrated either a TSX LFS 200 optical chaining module for entrance linkage via fiber optical bus or a TSX LES 200 electrical chaining module for entrance linkage via electric bus. In both cases, upgrade by use of a TSX ESY 007 module will be possible.

The upgrade solution offered by the TSX ESY 007 Module can substitute racks 0/1 and 2/3 with a Premium rack and keep Series 7 extension racks. Recovery of racks 0/1 and 2/3 is also possible. When this is the case, the Premium rack is added to the top of the I/O configuration.

Illustration:

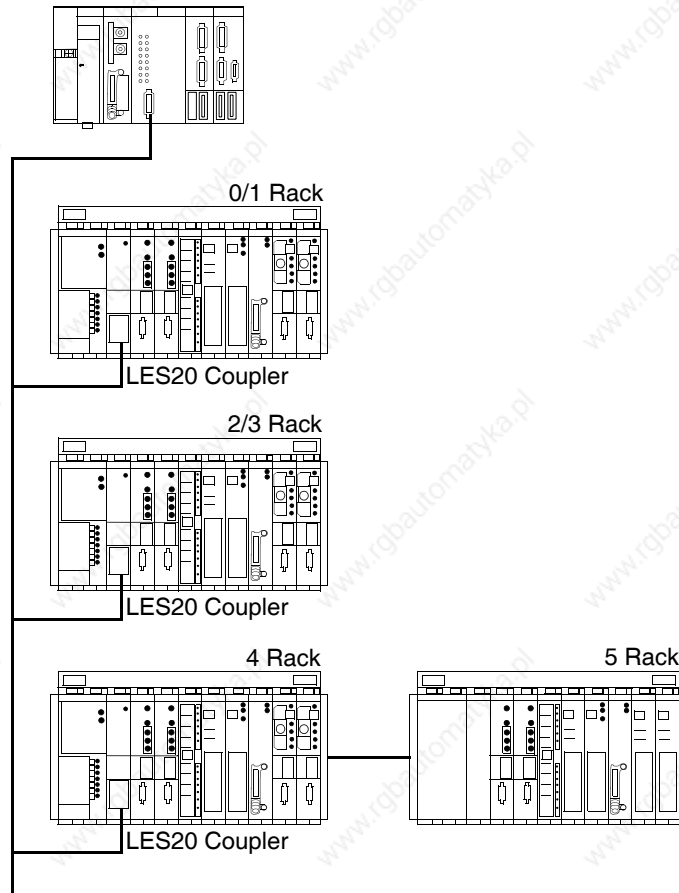

In the illustration below, the TSX Series 7 processor for the 0/1 rack was replaced by a TSX LES 20 coupler. A TSX LES 20 coupler was installed in position M of the 2/3 rack. The 2/3 rack is fitted with a power supply. These two couplers were connected to the I/O extension bus by two TSX LES 62 connector terminal blocks.

The existing TSX LES 65 terminal block that was previously plugged into the TSX Series 7 processor is now plugged into the front panel connector of the TSX ESY 007 coupler.

The TSX Series 7 PL7-3 processor application program was migrated to UNITY Pro software using PL7-3/PL7 Pro and PL7 Pro/UNITY Pro converters.

Recovering racks 0 to 3

At a Glance

Recovery of the 0/1 rack and the 2/3 rack managed as a direct extension is possible when the following conditions are met:

- Move the 2/3 rack from direct extension to local extension and install a TSX LES 20 Coupler in slot M with a power supply. On type RKE 8 racks, there are slots for installing a power supply and the TSX LES 20 Coupler. On the other hand, on type RKE 7 racks these slots do not exist and the cards in the first two slots must be removed in order to mount a power supply and the LES20 Coupler.
- Install a TSX LES 20 Coupler in the place of the Series 7 CPU in the 0/1 rack.
- In the LES62 terminal block of the LES20 module of the 0/1 rack, encode address 0 and in the LES62 terminal block of the LES20 module of the 2/3 rack, encode address 2.

Encoding addresses:



Address 0



Address 2

Illustration

Forward:

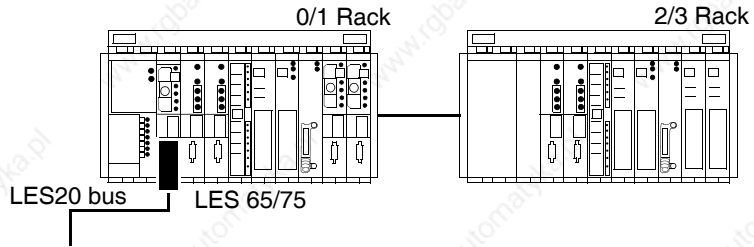

After:

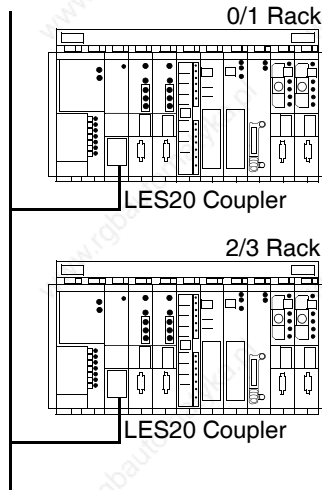

For double format racks

Recovering a double-format rack involves installing a LES20 Coupler in place of the processor in the lower part of the rack.

Recovering I/O modules on the upper side follows the same principle as for a double address rack. In the case of a double format direct extension I/O rack, a LES20 Coupler should be placed in slot M.

Illustration

Forward

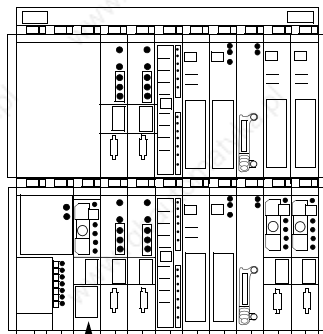

TSX Series 7 processor

After

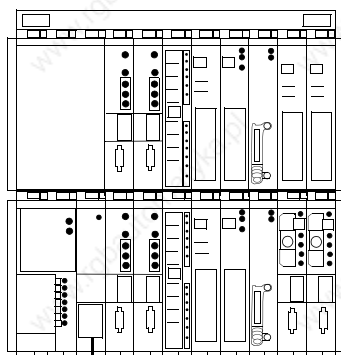

LES20 Coupler

to TSX ESY 007

LES120/LFS120 Remote Entrance Links

At a Glance

There are two types of links in configurations with I/O remote entrance linkage:

- Fiber optical remote I/O link: LFS-120,
- Electric remote I/O link: LES-120.

Recuperation of this type of remote link by the TSX ESY 007 coupler is possible if the base configuration is modified as indicated hereafter.

Optical configuration before configuration:

Illustration:

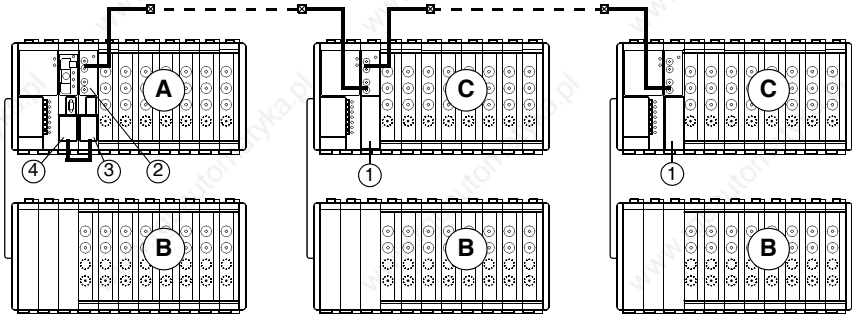

Definitions:

Code	Definition
A	PLC base tray
B	Direct extension input/output tray:
C	Remote optical direct extension input/output tray
1	TSX LFS 200 optical chaining module
2	TSX LFS 120 optical entrance link module
3	TSX LES 70 Module
4	TSX LES 74/75 Module

Optical configuration after upgrade:

Illustration:

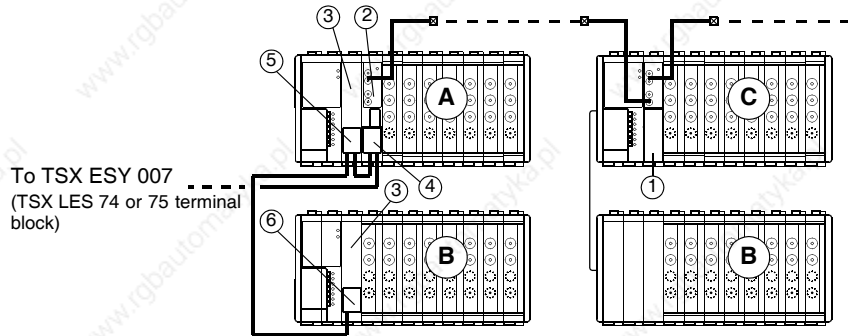

To TSX ESY 007
(TSX LES 74 or 75 terminal block)

Definitions:

Code	Definition
A	PLC base tray
B	Direct extension input/output tray:
C	Remote optical direct extension input/output tray
1	TSX LFS 200 optical chaining module
2	TSX LFS 120 optical entrance link module
3	TSX LES 20 Module
4	TSX LES 70 Module
5	TSX LES 62 Module
6	TSX LES 61 Module

The above principle is the same in the case of electrical entrance link architecture.

Methodology for Upgrading the PL7-3 PLC Program

At a Glance

The different steps for migrating a PL7-3 program of a TSX Series 7 PLC for updating to a UNITY Pro program are presented below. Porting a PL7-3 program to UNITY Pro requires the successive use of PL7-3/PL7 Pro and PL7 Pro/UNITY Pro converters. It also requires XTEL (V5 minimum), PL7-3 (V5 minimum), PL7 Pro (V4.3 minimum) and UNITY Pro (V2.1 minimum) software.

- Analysis of the I/O configuration of the PL7-3 program (under XTEL-CONF): establish the list of I/O modules supported by the TSX ESY 007 Module and those that are not supported.
- Modular backup under XTEL-PL7-3 of each part of the PL7-3 (PRL, G7, POST, Sri) program: obtain the text file (.LAD, .LIT, .GR7).
- Backup the symbols file (.SCY) and the constants file (.CST)
- Conversion of the exported files (.LAD, .LIT, .GR7, .SCY, .CST) to a PL7 Pro compatible file format (.LD, .ST, .GR7, .SCY) using the PL7-3/PL7 Pro converter associating PL7-3 and PL7 Pro objects.
- Creating a PL7 Pro receiving program and successive importing of compatible exported PL7-3 files. Be sure to respect the order in which you import the sections to preserve the structure of the source program.
- Exporting the PL7 Pro application to .FEF file.
- Creating the receiving station in UNITY Pro by adding the TSX ESY 007 Module and creating the I/O extension bus configuration.
- Importing the FEF application in UNITY Pro using the PL7 Pro/UNITY Pro converter associating PL7 Pro objects with UNITY Pro objects. The correspondence of the Series 7 I/Os with the UNITY Pro I/Os is described in detail in chapter 3.
- Adaptation of the program to the upgrade through the use of the TSX ESY 007 Module (Porting PL7-3 instructions for explicit read/write and text block send through the use of EF SEND_REQ in UNITY Pro).

For steps 1 to 5, see the documentation for the PL7-3/PL7 Pro converter (on-line converter help: [convpl73.hlp](#))

For step 8, see the documentation for the PL7 Pro/UNITY Pro converter (on-line UNITY help).

Key points for migrating a PL7-3 program to UNITY Pro

Application structure:

- A PL7-3 application may include up to seven tasks (six FAST/MAST/AUX0/AUX1/AUX2/AUX3 periodic tasks and one interruption task. A UNITY Pro application using the TSX ESY 007 Module can only include the MAST and FAST tasks for the I/O configured on the LES20 Bus.
- Modular backup and import of each part of the program involves a loss of program structure. Successful recovery of this structure is the responsibility of the user when importing into PL7 Pro. Because the PL7-3 task number is greater than the PL7 Pro task number, there may be collision problems that must be resolved by the user.

Objects:

- Objects handled by a PL7-3, PL7 Pro or UNITY Pro application are predefined. Some PL7-3 objects still exist in PL7 Pro and UNITY Pro, others not. A key point in conversion is to associate each PL7-3 object used with its equivalent in PL7 Pro then UNITY Pro.
- Converter documentation contains correspondence tables for PL7-3/PL7 Pro and PL7 Pro/UNITY Pro objects.

Languages syntax:

- The PL7-3 (LIT) literal language is transformed into structured language in PL7 Pro and UNITY Pro (ST). Syntactical differences exist between the two languages. A table of equivalencies is available in the documentation of the converters.
- The Ladder PL7-3 language is not processed in the same manner as the Ladder PL7 Pro and UNITY Pro language. In PL7-3, the Ladder is processed, for each rung, from left to right, column by column, and in each column from top to bottom. In PL7 Pro and UNITY Pro, the Ladder is processed connected network by connected network, and within a connected network, in the direction of the equation. Even though they are converted in identical graphical form, some networks of contacts may thus be processed differently (producing a different result on execution).
- The Grafcet language is transformed in UNITY Pro into SFC language. Because of this, some functions no longer exist and their migration is the responsibility of the user (Section PRL/POST, Jump,). Moreover, some execution rules are different (empty receptivity, macro steps). See the converter documentation for more information on the differences between Grafcet and the SFC language.

Hardware and software configuration:

- Software configuration is partially recovered. Configuring task parameters, memory (number of internal bits/words), management of common words and OFBs, information relating to Grafset are not recovered and are the responsibility of the user.

Explicit exchange instructions:

- Because the converters are not able to preserve the explicit exchange instructions with Series 7 modules, porting instructions is the user's responsibility.
 - The READEXT and WRITEEXT instructions, as well as the exchanges by text block send may be reproduced by using EF SEND_REQ and request send to the TSX ESY 007 Module.
-

2.3 Input/Output Extension Bus Diagnostics

I/O extension bus diagnostics - Presentation

Overview

LED indicators block for the modules allows:

- Indicator lights for the presence of each TSX7 rack configured in the UNITY Pro application.
- Indicator lights for the status of these TSX7 racks configured in the UNITY Pro application.

Illustration:

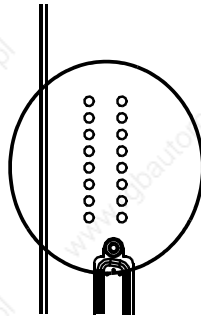

A green LED on indicates whether the corresponding TSX7 rack or one of its modules has a communication fault.

A flashing green LED indicates that the corresponding TSX7 rack or one of its modules has a communication fault.

2.4 Operating Modes of the TSX ESY CM 007 Module

TSX ESY 007 Module Operating Modes

Output fallback strategy

The fallback mode is defined for each TSX 7 rack in the configuration screen and may be read in the word %KWr.m.0:

- %KWr.m.0.i = 0: I/O fallback to 0 of the Series 7 rack number i on the I/O extension bus
- %KWr.m.0.i = 1: maintain I/O status of the Series 7 rack number i on the I/O extension bus

(r = address rack TSX ESY 007, m = TSX ESY 007 address module)

Operation:

On communication fault of TSX ESY 007 Module with TSX LES20 coupler:

- With **fallback** option to 0: outputs of this rack are forced to 0 until communication resumes.
- With **Maintain status** option: outputs of this rack are maintained in status until communication resumes.

Communication fault

In case of communication break with the CPU, following a CPU watchdog (in case of placement of TSX ESY 007 Module in the main rack), or removal of the X Bus cable (in the case of a placement of TSX ESY 007 Module in an extension rack), the module sends outputs in fallback to 0 or to maintain according to the chosen configuration.

Extracting a module with power on

When extracting a module with power on, communication with the X bus stops, the processor signals a module fault.

Communication on the I/O extension bus is also interrupted with warning. In this case, the Series 7 racks put their outputs in the desired status (maintain or fallback).

Module Fault

In the event of a serious TSX ESY 007 Module fault (defective component, etc.), the module stops communicating with the X Bus and with the I/O extension bus. The same behavior also occurs when extracting a module with power on.

Inserting a module with power on

After power-up, the TSX ESY 007 Module waits to receive the configuration from the processor, until which it remains stopped.

Outage of I/O extension medium

In the event of medium outage, several situations are possible:

- The medium is cut off or disconnected from the module output: Disappearance of all Series 7 modules and activation of corresponding channel fault bits and the module fault bit.
 - The medium is disconnected from some Series 7 racks (the TSX LES 61/62 terminal blocks are present but disconnected from the TSX LES 20 modules): Disappearance of disconnected Series 7 modules and activation of corresponding channel fault bits and the module fault bit. Communication with the remaining Series 7 Modules is maintained. The disconnected Series 7 racks enter fallback or maintain mode according to their configurations.
 - The medium is cut off after the TSX ESY 007 Module and several Series 7 racks (complete cut off of the medium): Disappearance of disconnected Series 7 modules and activation of corresponding channel fault bits and the module fault bit. Communication with the remaining modules is possible but possibly affected by communication error. The disconnected Series7 racks enter fallback or maintain mode according to their configurations.
-

2.5 Precautions for Use

Double rack addressing

Recommendations

When connecting the I/O extension bus to the TSX ESY 007 Module, do not assign the same address to two Series 7 racks by encoding TSX LES 61/62 module terminal blocks or encoding LES200 and LFS200.

Illustration

A single combination of the connectors below by terminal block LES61/62.

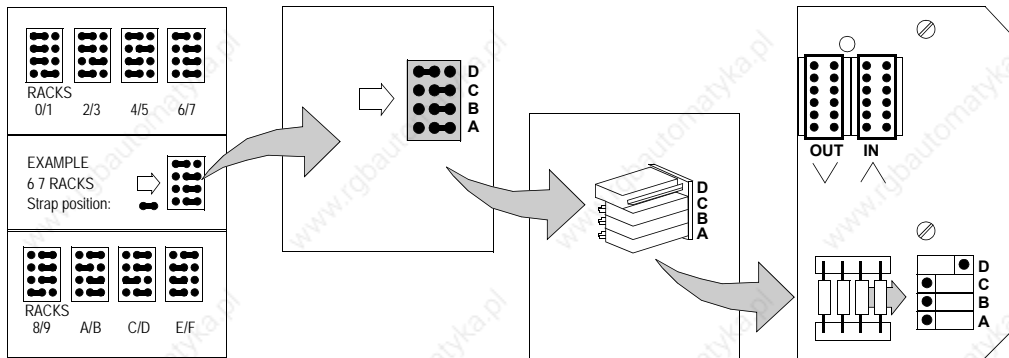

Software Installation for the TSX ESY 007 Module



At a Glance

Subject of this Section

This section covers software installation for the TSX ESY 007 Module with UNITY Pro software.

What's in this Part?

This part contains the following chapters:

Chapter	Chapter Name	Page
3	TSX ESY 007 Module Software Installation - Principles	57
4	Configuring the TSX ESY 007 Module	75
5	Debugging the TSX ESY 007 Module	89
6	Performance of the TSX ESY 007 Module	99
7	Language Objects of the TSX ESY 007 Module	101

TSX ESY 007 Module Software Installation - Principles

3

At a Glance

Subject of this Chapter

This chapter presents the software installation principles for the TSX ESY 007 Module.

What's in this Chapter?

This chapter contains the following topics:

Topic	Page
Installation of the I/O extension bus - Presentation	58
TSX ESY 007 Module Architecture	60
Structure of a Series 7 module	61
Addressing Language Objects Associated with Series 7 Devices On the I/O Extension Bus	63
Use of EF SEND_REQ for Handling Series 7 Modules with Extended and Message Registers	65

Installation of the I/O extension bus - Presentation

Introduction

The TSX ESY 007 Module allows Series 7 rack control via a Premium PLC programmed with Unity Pro software. The TSX ESY 007 Module is used for revamping automated systems equipped with TSX Series 7 programmable PLCs. It allows creation of a gateway between a Premium PLC and the I/O serial extension bus of TSX Series 7 PLCs. It offers the possibility of replacing the main rack of a TSX Series 7 system by a TSX Premium rack and keeping the TSX Series 7 extension racks. It thus allows recuperation of all extension racks in a TSX Series 7 by connecting and controlling the input/output serial extension bus.

It thus offers a solution to modernize TSX Series 7 systems and benefit from Premium / UNITY technology without having to redo all the cabling of the I/O modules.

Installation of the TSX ESY 007 Module frame requires definition of the physical context of the project in which it will be used (rack, power supply, processor, modules, Series 7 devices connected by the bus), followed by installation of the software. The software installation of the application-specific modules is carried out from the various Unity Pro editors:

- in offline mode,
- and in online mode.

The following order of installation phases is recommended but it is possible to change the order of certain phases (for example, starting with the configuration phase).

Installation of the TSX ESY 007 Module The table below shows the various phases of installation of the TSX ESY 007 Module:

Phase	Description	Mode
Declaration of variables	Declaration of IODDT-type variables for the application-specific modules and project variables.	Offline (1)
Programming	Programming of the project and functions of the TSX ESY 007 Module.	Offline (1)
Configuration	Declaration of Series 7 modules and devices. Module channel configuration. Entry of configuration parameters.	Offline
Association	Association of IODDTs with the modules configured (variable editor).	Offline (1)
Build	Project generation (analysis and editing of links).	Offline
Transfer	Transfer project to PLC.	Online
Adjustment / Debugging	Debug project from debug screens, animation tables. Modifying the program and adjustment parameters.	Online
Documentation	Building documentation file and printing miscellaneous information relating to the project.	Online (1)
Operation / Diagnostic	Displaying miscellaneous information necessary for supervisory control of the project. Diagnostic of project and modules.	Online

(1): These various phases can also be performed in the other mode.

*: Predefined structure containing standard language objects of the module.

TSX ESY 007 Module Architecture

At a Glance

The TSX ESY 007 Module operates according to master/slave modes. The master alone commands exchanges on the bus.

The module integrates data fields that allow to manage Series 7 module lists and the images of input/output data.

Illustration of the architecture

The figure below shows the architecture of the TSX ESY 007 Module.

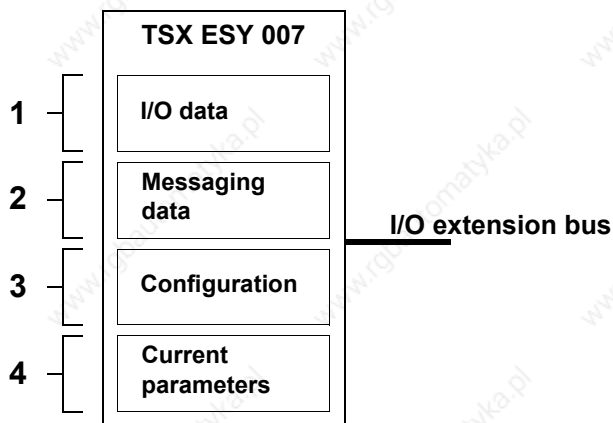

Description of components

The table below shows the different elements that make up the architecture of the TSX ESY 007 Module.

Address	Element	Description
1	I/O data	Images of the I/O of the 16 8-slot racks.
2	Messaging data	Image of the messages sent to Series 7 modules.
3	Configuration	This field contains all the codes of the Series 7 I/O modules configured on the I/O extension bus.
4	Current parameters	Image of the parameters of all Series 7 modules and racks.

Structure of a Series 7 module

At a Glance

The TSX ESY 007 Module allows to control the 128 Series 7 devices in the following list:

Discrete I	Discrete O	I ANA	O ANA	Other
TSX DET 4 66	TSX DST 4 17	TSX AEM 4 11	TSX ADT 2 01	TSX AXT 2 00
TSX DET 8 02	TSX DST 8 04	TSX AEM 4 12	TSX ADT 2 02	TSX CCM 1 00
TSX DET 8 03	TSX DST 8 05	TSX AEM 4 13	TSX ADT 2 03	TSX CTM 1 00
TSX DET 8 05	TSX DST 8 17	TSX AEM 8 11	TSX AST 2 00	TSX DTM 1 00
TSX DET 8 12	TSX DST 8 35	TSX AEM 8 21	TSX ASR 2 00	TSX DMR 16 52
TSX DET 8 13	TSX DST 8 82	TSX AEM 12 12	TSX ASR 4 01	TSX DEM 24xx
TSX DET 8 14	TSX DST 16 04	TSX AEM 16 01	TSX ASR 4 02	
TSX DET 8 24	TSX DST 16 12	TSX AEM 16 02	TSX ASR 4 03	
TSX DET 16 03	TSX DST 16 32	TSX AEM 16 13	TSX ASR 8 00	
TSX DET 16 04	TSX DST 16 33			
TSX DET 16 12	TSX DST 16 34			
TSX DET 16 13	TSX DST 16 35			
TSX DET 16 33	TSX DST 16 82			
TSX DET 32 12	TSX DST 24 72			
TSX DET 32 32	TSX DST 24 82			
TSX DET 32 42	TSX DST 32 92			
TSX DET 32 52				

The Discrete input modules have 4, 8 or 16 input channels. The 32-channel modules are represented as two 16-channel modules in the same slot of the even-numbered rack and the next odd-numbered rack.

Discrete output modules have 4, 8 or 16 output channels. The 32-channel modules are represented as two 16-channel modules in the same slot of the even-numbered rack and the next odd-numbered rack.

The ANA input modules have 16 Discrete channels, 8 analog input channels and 8 analog output channels. Some even have an internal memory area called "extended registers" that allow management of more than 8 analog channels.

The ANA output modules have 16 Discrete output channels, 8 analog input channels and 8 analog channels for output.

The other ANA modules have either:

- 16 Discrete input channels, 8 analog input channels and 8 analog output channels.
- 16 Discrete output channels, 8 analog input channels and 8 analog output channels.
- 8 Discrete input channels, 8 Discrete output channels, 8 analog input channels and 8 analog output channels.

Some also have an internal memory area called "extended registers" that allow management of more than 8 analog channels and a second internal memory area called "message registers" that allows management of messages.

Addressing Language Objects Associated with Series 7 Devices On the I/O Extension Bus

At a Glance

Acquisition of inputs and updating of outputs from Series 7 devices connected to the I/O extension bus are performed in two different ways based on the channel type at the start and the end of each device type:

- automatically, respectively at the beginning and at the end of each scan of the task for which they are configured for the Discrete and ANA implicit I/O objects,
- by messaging with the use of EF SEND_REQ for objects based on extended registers and message registers.

The program user has access to these inputs and these outputs by language objects.

Addressing is defined as follows:

%	I,Q,IW,QW \	b.1 \	r	.	m	.	c
Symbol	Object type	Bus number followed by .1	Rack No.		Module position		channel

Syntax

The table below describes the different elements included in addressing:

Family	Element	Values	Meaning
Symbol	%	-	-
Object type	I Q IW QW	-	Image of the All or None module input, Image of the All or None module output, Image of the analog input of the module, Image of the analog output of the module, This information is exchanged automatically for each cycle of the task to which they are attached.
Bus no.	b	2 to 999	Bus number (assigned by UNITY Pro)
Rack No.	r	0 to 15	Series 7 rack number
Module position	m	0 to 7	Series7 module number
Channel	c	0 to 15	Channel number

Example

`%I\3.1\0.2.6` indicates: input 6 of Series 7 module in slot 2 of 0 rack (formerly I2,6 in PL7-3).

Illustration:

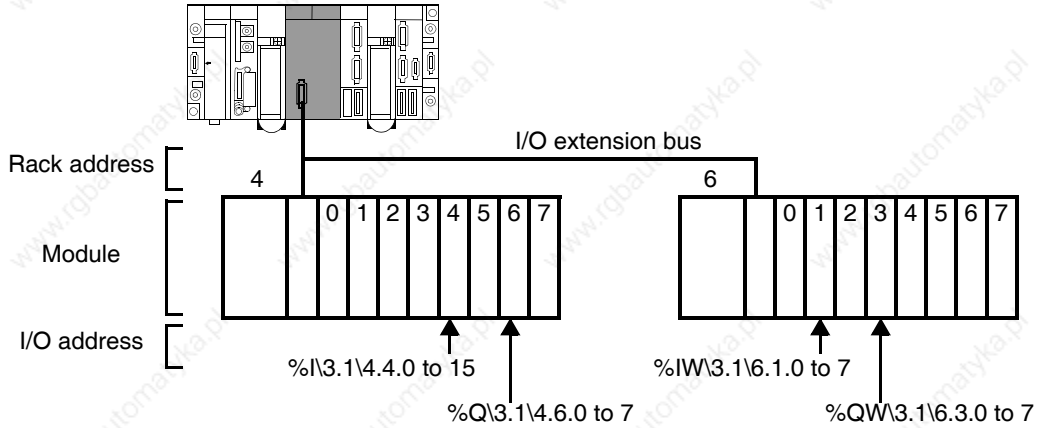

Word bit addressing for an analog variable

To address a word bit, comply with the following syntax:

<code>%</code>	<code>IW/QW</code>	<code>\b.1\</code>	<code>r</code>	<code>.</code>	<code>m</code>	<code>.</code>	<code>c</code>	<code>.0.</code>	<code>i</code>
Symbol	Object type	Bus number followed by .1	Rack No.		Module position		Channel		Bit position

Example: `%IW\3.1\0.5.6.0.4` indicates: bit 4 of analog input 6 for the Series 7 module in slot 5 of rack 0 (formerly IW5,6:X4 in PL7-3).

Multiple addressing

When connecting one or several Series 7 racks, do not assign an address already used by another rack on the bus.

In the event of double rack addressing, two cases can occur:

- the two racks are composed of the same I/O modules: the TSX ESY 007 Module does not detect any error on output modules but detects transmission errors on the input modules,
- the two racks are not composed of the same I/O modules: the TSX ESY 007 Module does not detect any error on identical modules but detects transmission errors on the different modules.

Use of EF SEND_REQ for Handling Series 7 Modules with Extended and Message Registers

At a Glance

Some Series 7 modules have a specific operation mode for management of analog channels and for management of their internal configuration. They have two internal memory areas respectively called "extended register" and "message register".

The former allows management of analog channels and the latter allows management of module configuration modes.

Management with PL7-3

PL7-3 software allowed, through the use of the "send text block, explicit read/write" functions to communicate with the extended register areas and message register areas of the Series 7 Modules.

The table below describes the different PL7-3 functions for dialogue with the extended and message registers:

Instruction	Meaning
READEXT	Read Series 7 module extended registers and store in a PLC internal word area.
WRITEEXT	Write Series 7 module extended registries from a PLC internal word area.
CPL TXT	Coupler type text block for sending PLC internal words area and receiving data for configuration, reading data and diagnostic of Series 7 module.

Note: For all additional information on the use of explicit read/write instructions and sending text block (procedure for transfer of a configuration for example), see the TSX Series 7 documentation.

Management using Unity Pro

The TSX ESY 007 Module allows, with the use of EF SEND_REQ, emulation of PL7-3 instructions for managing Series 7 modules with extended and message registries.

With the TSX ESY 007 Module, EF SEND_REQ is used in the following manner:

SEND_REQ(ADDR('r.m.SYS'),C,%MWx:x,%MWy:4,%MWz:z); with

- ADDR('r.m.SYS') address encoding of the TSX ESY 007 Module,
- C the request code to send to the TSX ESY 007 Module ,%MWx:x the table containing data to send to the TSX ESY 007 Module,
- %MWy:4 the exchange management table with the TSX ESY 007 Module,
- %MWz:z the receive table of the TSX ESY 007 Module response.

Illustration Send identification request

```

if RE (%M0) then
%mw13:=0;
SEND_REQ(ADDR('0.4.SYS'),16#0F,%MW0:1,%MW10:4,%MW100:24);
end_if;

```

Illustration Send request for read object

```

if RE (%M0) then
%mw13:= 8;
%MW0: = 16#0696;
%MW1: = 16#0101;
%MW2: = 16#00FF;
%MW3: = 16#0001;
SEND_REQ(ADDR('0.4.SYS'),16#82,%MW0:4,%MW10:4,%MW100:24);
end_if;

```

The table containing data to send to the coupler (%MW0:4 in the illustration above) contains a series of bytes representing the send request. The contents and length of this table depends on the type of request to send.

The management table of the data exchange with the coupler (%MW10:4 in the illustration above) is a 4-word table containing the following information:

	Word number	Most significant bit of the word	Least significant bit of the word
System data	1	Exchange number	Activity bit
	2	Request response	Communication result
User data	3	Timeout to apply to the request	
	4	Length of request to be broadcast, then length received in response.	

The receive table (%MW100:24 in the above illustration) contains the response request sent by the TSX ESY 007 Module. The contents and length of this table depend on the type of send request.

Read extended registers To emulate the READEXT instruction with the TSX ESY 007 Module, the EF SEND_REQ parameters are the following:

Parameter	Meaning	Values (hexadecimal)
ADDR('r.m.SYS')	address encoding of the TSX ESY 007 Module	
C	request code	82
%MWx:4	table containing send data	0696,FFii,00FF,0001 with ii the address of the Series 7 recipient (rack*8 + module = 0 to 127)
%MWy:4	exchange management table	xxxx,xxxx (exchange result), 000A (exchange timeout), 0008 (transmit time except for DEM24xx modules with the request code 1 which requires a length of 12)
%MWz:20	response receive table	only if response.

The management and receive tables contain the following data if the exchange was successful:

- %MWy[1]=16#B200,
- %MWy[3]=
 - 16#002A if TSX AEM 1601/1602/1603 module,
 - 16#0024 if TSX AEM 1212 module,
 - 16#001C if TSX AEM 821 module,
- %MWz[0-2] contains the request header: 16#0696, 16#FFii, 16#0100,
- %MWz[3] contains the status of the exchange with the Series 7 module (16#FE if exchange OK, 16#FD if exchange KO),
- %MWz[4 to 19] contains the data for the 16 analog channels for the Series 7 TSX AEM 16xx modules,
- %MWz[4 to 16] contain the data for the 13 analog channels for the Series 7 TSX AEM 1212 module (13th channel: Cold Junction),
- %MWz[4 to 11] contain the data for the 8 analog channels for the Series 7 TSX AEM 821 module.

Illustration

```

if RE (%M1) then
%mw13:= 8;
%MW0: = 16#0696;
%MW1: = 16#FF01;
%MW2: = 16#00FF;
%MW3: = 16#0001;
SEND_REQ (ADDR ('0.4.SYS'), 16#82, %MW0:4, %MW10:4, %MW100:20);
end_if;

```

Note: Use of EF SEND_REQ to reproduce a READEXT instruction is only possible on the following module: TSX AEM 821, TSX AEM 1212, TSX AEM 1601, TSX AEM 1602 and TSX AEM 1613.

Write extended registers

To emulate the WRITEEXT instruction with the TSX ESY 007 Module, the EF SEND_REQ parameters are the following:

Parameter	Meaning	Values (hexadecimal)
ADDR('r.m.SYS')	address encoding of the TSX ESY 007 Module	
C	request code	83
%MWx:20	table containing send data	0696,FEii,00FF,0001,jj...jj with ii the address of the destination Series 7 module (rack*8 + module = 0 to 127) and jj..jj the data for the 8 registers for the TSX ASR 800 module
%MWy:4	exchange management table	xxxx,xxxx (exchange result), 000A (exchange timeout), 0018 (transmit time)
%MWz:4	response receive table	only if response.

The management and receive tables contain the following data if the exchange was successful:

- %MWy[1]=16#B300,
- %MWy[3]=16#0008,
- %MWz[0-2] contains the request header: 16#0696, 16#FEii, 16#0100,
- %MWz[3] contains the status of the exchange with the Series 7 module (16#FE if exchange OK, 16#FD if exchange KO).

Illustration

```
if RE (%M2) then
%mw13 := 16#28;
%MW0: = 16#0696;
%MW1: = 16#FE01;
%MW2: = 16#00FF;
%MW3: = 16#0001;
%MW3: = 16#1234;
...
SEND_REQ(ADDR('0.4.SYS'),16#83,%MW0:20,%MW10:4,%MW100:4);
end_if;
```

Note: Use of EF SEND_REQ to reproduce a WRITEEXT instruction is only possible on the TSX ASR 800 module.

Read message registers To emulate the use of send text block to read data using the TSX ESY 007 Module, the parameters of the EF SEND_REQ instruction are the following:

Parameter	Meaning	Values (hexadecimal)
ADDR('r.m.SYS')	address encoding of the TSX ESY 007 Module	
C	request code	82
%MWx:4	table containing send data	0696,jjii,00FF,00kk, nn..nn with ii the address of the Series 7 destination module (rack*8 + module = 0 to 127), jj the request code (1=read data, 3= read threshold 0 value, 5= read threshold 1 value, 41=read configuration, 47= read default chain, 4A=read application name, F=read version, F7= read parameters) and kk the amount of data in bytes: see table below)
%MWy:4	exchange management table	xxxx,xxxx (exchange result), 000A (exchange timeout), 0008 (transmit time)
%MWz:zz	response receive table	only if response.

The management and receive tables contain the following data if the exchange was successful:

- %MWy[1]=16#B200,
- %MWy[3]=16#00xx where xx is the length received according to the request (kk+8),
- %MWz[0-2] contains the request header: 16#0696, 16#jjii, 16#kk00,
- %MWz[3] contains the status of the exchange with the Series 7 module (16#81 if exchange OK for request 16#01, 16#83 if exchange OK for request 16#03, 16#85 if exchange OK for request 16#05, 16#71 if exchange OK for request 16#41, 16#77 if exchange OK for request 16#47, 16#7A if exchange OK for request 16#4A, 16#3F if exchange OK for request 16#0F, 16#FD if exchange KO),
- %MWz[4 to kk+4] contains the data received.

TSX Series 7 Module	Request code (Hexa)	Length (decimal)	Meaning
AEM 411/412/413	41	4 to 36 bytes	Read configuration
	47	6 bytes	Character string fault
	4A	1 to 20 bytes	Read application name
	F	27 bytes	Read version

TSX Series 7 Module	Request code (Hexa)	Length (decimal)	Meaning
AEM 811/821	1	16 bytes	Read 8 channel ANA,
	3	16 bytes	Read threshold 0
	5	16 bytes	Read threshold 1
	41	4 to 68 bytes	Read configuration
	47	10 bytes	Character string fault
	4A	1 to 20 bytes	Read application name
	F	27 bytes	Read version
AEM 1212	1	26 bytes	Read 12 channels ANA, + Cold Junction
	41	74 bytes	Read configuration
	47	10 bytes	Character string fault
	4A	1 to 20 bytes	Read application name
	F	27 bytes	Read version
AEM 1601/1602	1	32 bytes	Read 16 channel ANA,
	41	34 bytes	Read configuration
	47	12 bytes	Character string fault
	4A	1 to 20 bytes	Read application name
	F	27 bytes	Read version
AEM 1613	1	32 bytes	Read 16 channel ANA,
	3	32 bytes	Read threshold 0
	5	32 bytes	Read threshold 1
	41	98 bytes	Read configuration
	47	12 bytes	Character string fault
	4A	1 to 20 bytes	Read application name
	F	27 bytes	Read version
CCM 100	41	16/18 or 6 to 92 bytes	Read configuration
	47	4 bytes	Character string fault
	4A	1 to 20 bytes	Read application name
	F	27 bytes	Read version
CTM 100 / DTM 100	41	16 or 6 to 108 bytes	Read configuration
	47	4 bytes	Character string fault
	4A	1 to 20 bytes	Read application name
	F	27 bytes	Read version
	F7	2 bytes	Read parameters before PWF

TSX Series 7 Module	Request code (Hexa)	Length (decimal)	Meaning
DEM 24xx	1	1 to 234 bytes	Read setpoints
	41	18 bytes	Read configuration
	47	12 bytes	Character string fault
	4A	1 to 20 bytes	Read application name
	F	27 bytes	Read version

Write message registers

To emulate the use of send text block to write data using the TSX ESY 007 Module, the parameters of the EF SEND_REQ instruction are the following:

Parameter	Meaning	Values (hexadecimal)
ADDR('r.m.SYS')	address encoding of the TSX ESY 007 Module	
C	request code	83
%MWx:xx	table containing send data	0696,jjii,00FF,00kk, nn..nn with ii the address of the Series 7 destination module (rack*8 + module = 0 to 127), jj the request code (2= read threshold value 0 or time, 4=write threshold value 1, 40=write configuration, 49=write application name) and kk the amount of data in bytes, based on the request (see table below) and nn..nn the data to send
%MWy:4	exchange management table	xxxx,xxxx (exchange result), 000A (exchange timeout), 00mm (transmit time with mm=kk+8)
%MWz:4	response receive table	only if response.

The management and receive tables contain the following data if the exchange was successful:

- %MWy[1]=16#B300,
- %MWy[3]=16#0008,
- %MWz[0-2] contains the request header: 16#0696, 16#jjii, 16#kk00,
- %MWz[3] contains the status of the exchange with the Series 7 module (16#FE if exchange OK, 16#FD if exchange KO).

TSX Series 7 Module	Request code (Hexa)	Length (Decimal)	Meaning
AEM 411/412/413	40	4 to 36 bytes	Write configuration
	49	1 to 20 bytes	Write application name

TSX Series 7 Module	Request code (Hexa)	Length (Decimal)	Meaning
AEM 811/821	2	16 bytes	Write threshold 0
	4	16 bytes	Write threshold 1
	40	4 to 68 bytes	Write configuration
	49	1 to 20 bytes	Write application name
AEM 1212	40	74 bytes	Write configuration
	49	1 to 20 bytes	Write application name
AEM 1601/1602	40	34 bytes	Write configuration
	49	1 to 20 bytes	Write application name
AEM 1613	2	32 bytes	Write threshold 0
	4	32 bytes	Write threshold 1
	40	98 bytes	Write configuration
	49	1 to 20 bytes	Write application name
CCM 100	40	16/18 or 6 to 92 bytes	Write configuration
	49	1 to 20 bytes	Write application name
CTM 100 / DTM 100	40	16 or 6 to 108 bytes	Write configuration
	49	1 to 20 bytes	Write application name
DEM 24xx	2	8 bytes	Write
	40	18 bytes	Write configuration
	49	1 to 20 bytes	Write application name

Error management

If an exchange error occurs between the EF SEND_REQ and the TSX ESY 007 module, an error request code (16#FD) is returned in the second exchange management table word.

16#FD returned may mean the following:

- module TSX ESY 007 absent or faulty,
- maximum number of requests processed per TSX ESY 007 module (4/mast cycle) attained,
- exchange destination module TSX Series 7 absent or faulty,
- exchange destination module TSX Series 7 cannot support request,
- exchange destination module TSX Series 7 cannot support length to be written,
- exchange destination module TSX Series 7 cannot support length to be read,
- exchange destination module TSX Series 7 not ready.

Configuring the TSX ESY 007 Module

4

At a Glance

Subject of this Chapter

This chapter describes the configuration process during set-up of the I/O extension bus.

What's in this Chapter?

This chapter contains the following topics:

Topic	Page
Declaring a TSX ESY 007 Module in the PLC rack	76
Description of the Configuration Screen of a TSX ESY 007 Module	77
Declaring a Series 7 Device to the TSX ESY 007 Module	79
Displaying the I/O Extension Bus in the Project Browser	82
Modifying the software configuration of a TSX ESY 007 Module	84
Accessing the Description of a Series 7 Module	85
Accessing the Description of a Series 7 Rack.	86
Accessing the Description of a Series 7 Module	87
Modifying General Parameters of a Series 7 Rack	88

Declaring a TSX ESY 007 Module in the PLC rack

Procedure This operation allows insertion of a TSX ESY 007 Module in the PLC rack.

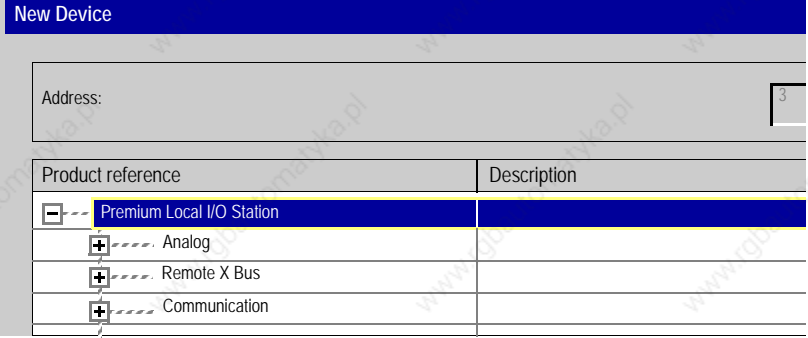
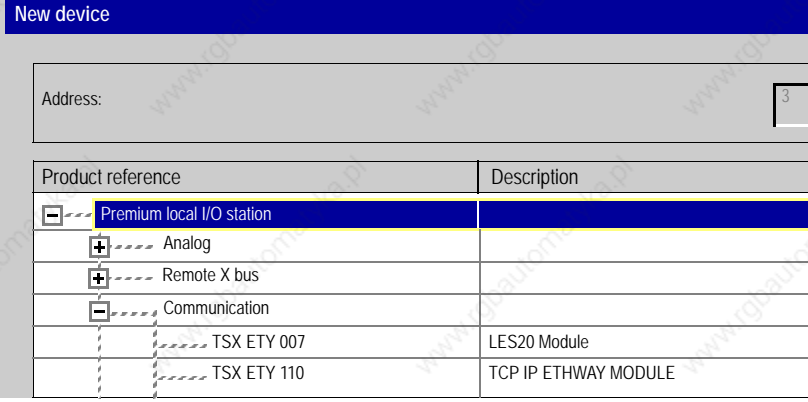
Step	Action
1	Open the hardware configuration editor.
2	Select the slot in which you wish to insert the module.
3	<p>Select the New device command in the context menu. Result: The New device window appears.</p> 
4	<p>Develop the Premium local input/output station and the Communication lines by clicking on the + sign. Result:</p> 
5	Select the TSX ESY 007 Module then confirm by clicking on OK.

Description of the Configuration Screen of a TSX ESY 007 Module

At a Glance

The configuration screen is a graphic tool designed for configuring a selected module in a rack. It provides access to the module's parameters and to devices on the I/O extension bus.

The configuration of this coupler in UNITY Pro is protected by access rights. These rights may only be used by Schneider Services Industries entities in France, and abroad by Schneider Services entities or otherwise by its representatives.

Illustration

The diagram below shows a configuration screen.

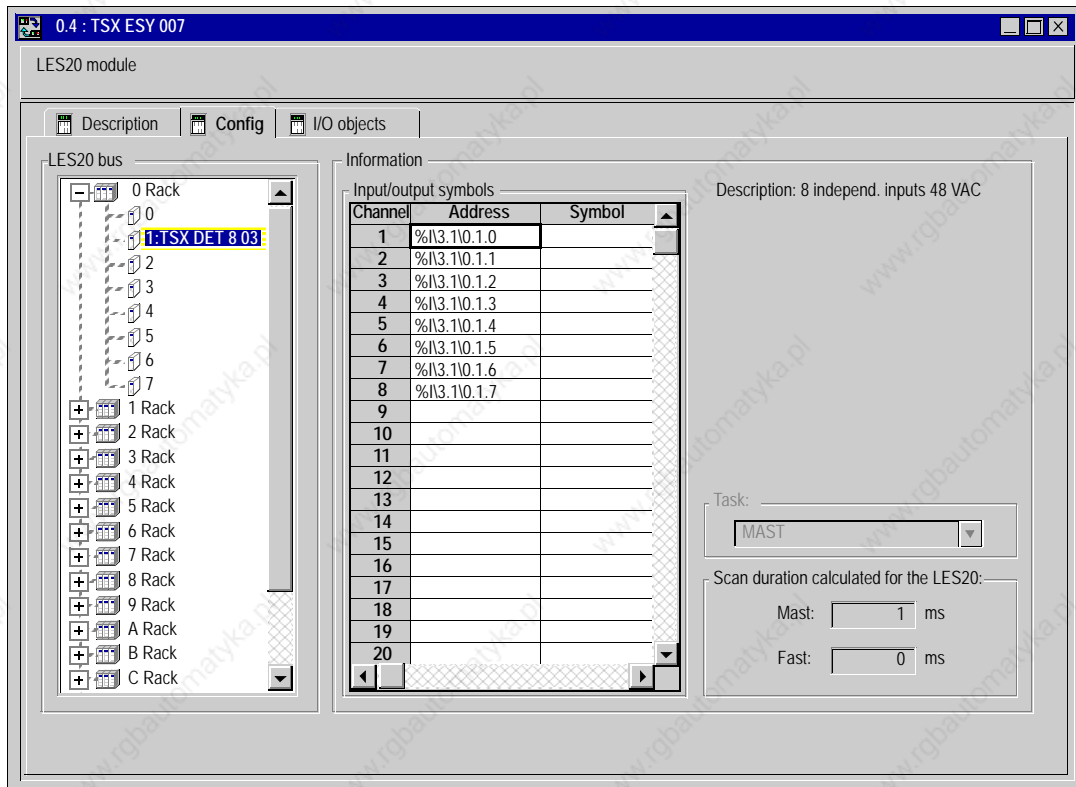

The front tab indicates the currently used mode (**Config** in this example). Each mode may be selected using the tab for the mode.

The following modes are available:

- **Description**,
- **Config** (configuration),
- **Debug** (or Diagnostics), accessible only in online mode.
- **Diagnostics** (Fault) only accessible in online mode.

The **I/O objects** tab (See UNITY Pro Manual, Operation modes, I/O objects tab for a module) allows to presymbolize the I/O objects.

The configuration screen allows you to choose or view the following features:

- The behavior of the Series 7 rack in fallback mode,
- The entrance link of the Series 7 rack (local, electrical or optical),
- The task controlling a Series 7 module,
- The I/O objects of a Series 7 module,
- The theoretical scan time of the I/O extension bus in milliseconds for MAST and FAST tasks.

Note: The PLC scan time must be configured in periodic mode and not in scan mode and with a task period calculated according to the following formula:

"Mast/Fast task scan time> Theoretical Mast/Fast I/O bus scan time + Execution time of the Mast/Fast program task".

The execution time of the program for a given task may be calculated from %SW30 to 35. Please see Chapter 6 for details on I/O extension bus scan time.

In debug phase, information on the real scan time of the I/O extension bus (current and maximum) is provided to allow more exact adjustment of the PLC scan time.

If using messaging with the TSX Series 7 modules by EF SEND_REQ, also provide request processing time during the master task period.

Declaring a Series 7 Device to the TSX ESY 007 Module

At a Glance

The Unity Pro software offers a catalog including all Series 7 modules available. This catalog is structured in families:

- discrete inputs,
- discrete outputs,
- ANA inputs,
- ANA outputs,
- other.

Procedure

This operation is used to declare a Series 7 device on the I/O extension bus.

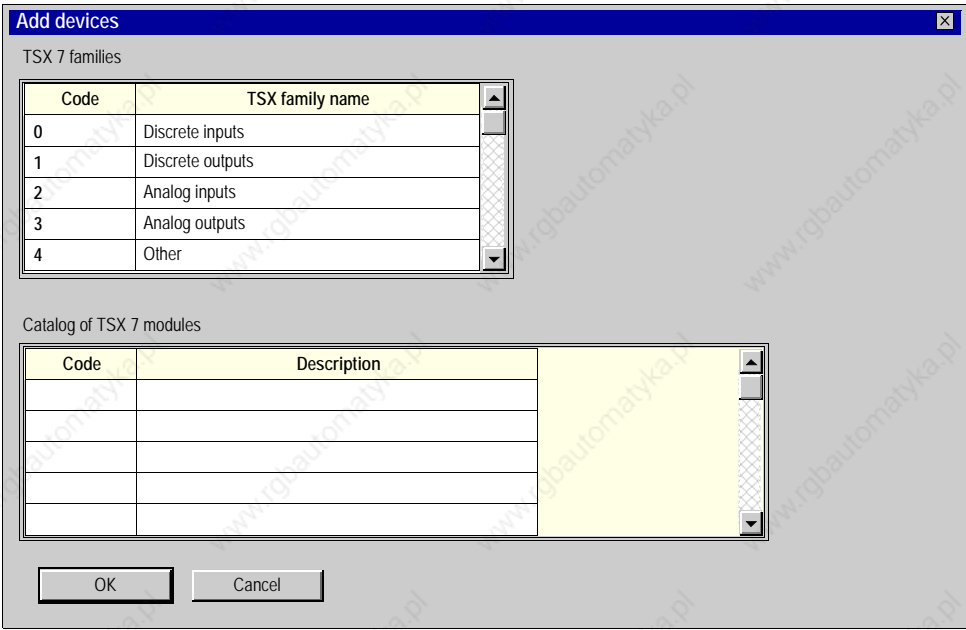
Step	Action																														
1	Access the hardware configuration screen of the TSX ESY 007 Module.																														
2	<p>In the I/O extension bus field, double click in the cell corresponding to the receiving slot number of the new device (0 rack to F, slot 0 to 7) or select that cell then execute the Edit command. Add a Series 7 module.</p> <p>Results: The Add a module screen appears.</p>  <table border="1" data-bbox="259 837 753 1032"> <thead> <tr> <th>Code</th> <th>TSX family name</th> </tr> </thead> <tbody> <tr> <td>0</td> <td>Discrete inputs</td> </tr> <tr> <td>1</td> <td>Discrete outputs</td> </tr> <tr> <td>2</td> <td>Analog inputs</td> </tr> <tr> <td>3</td> <td>Analog outputs</td> </tr> <tr> <td>4</td> <td>Other</td> </tr> </tbody> </table> <table border="1" data-bbox="259 1101 1009 1295"> <thead> <tr> <th>Code</th> <th>Description</th> </tr> </thead> <tbody> <tr><td> </td><td> </td></tr> <tr><td> </td><td> </td></tr> <tr><td> </td><td> </td></tr> <tr><td> </td><td> </td></tr> <tr><td> </td><td> </td></tr> <tr><td> </td><td> </td></tr> <tr><td> </td><td> </td></tr> <tr><td> </td><td> </td></tr> </tbody> </table>	Code	TSX family name	0	Discrete inputs	1	Discrete outputs	2	Analog inputs	3	Analog outputs	4	Other	Code	Description																
Code	TSX family name																														
0	Discrete inputs																														
1	Discrete outputs																														
2	Analog inputs																														
3	Analog outputs																														
4	Other																														
Code	Description																														

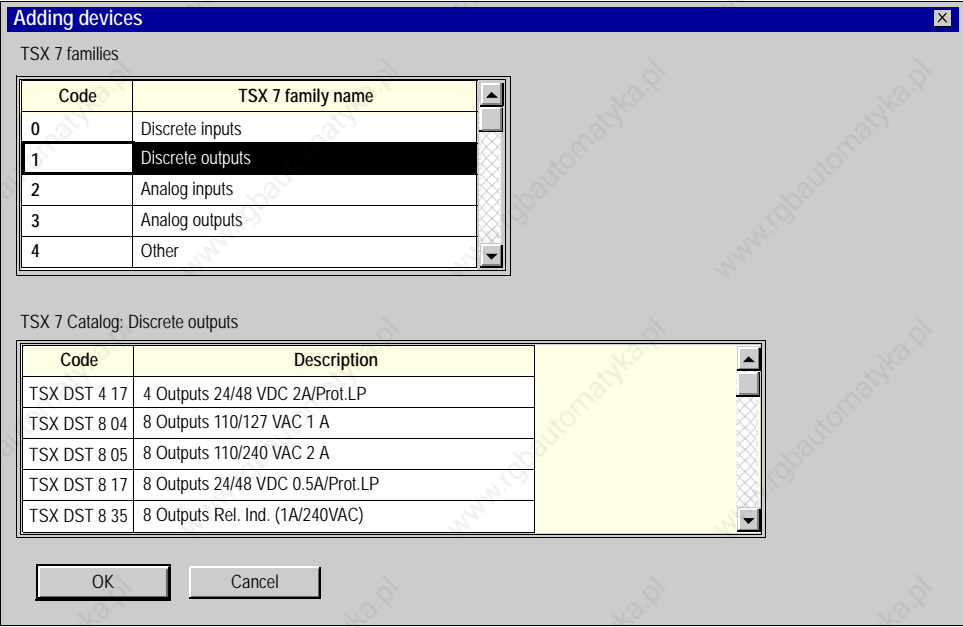
Step	Action																								
3	<p>In the TSX7 family name field, select the desired family. Results: The Modules catalog linked to the selected family appears.</p>  <p>The screenshot shows a dialog box titled "Adding devices". It contains two tables. The first table, "TSX 7 families", has columns "Code" and "TSX 7 family name". The second table, "TSX 7 Catalog: Discrete outputs", has columns "Code" and "Description".</p> <table border="1" data-bbox="285 337 779 532"> <thead> <tr> <th>Code</th> <th>TSX 7 family name</th> </tr> </thead> <tbody> <tr> <td>0</td> <td>Discrete inputs</td> </tr> <tr> <td>1</td> <td>Discrete outputs</td> </tr> <tr> <td>2</td> <td>Analog inputs</td> </tr> <tr> <td>3</td> <td>Analog outputs</td> </tr> <tr> <td>4</td> <td>Other</td> </tr> </tbody> </table> <table border="1" data-bbox="285 597 1035 792"> <thead> <tr> <th>Code</th> <th>Description</th> </tr> </thead> <tbody> <tr> <td>TSX DST 4 17</td> <td>4 Outputs 24/48 VDC 2A/Prot.LP</td> </tr> <tr> <td>TSX DST 8 04</td> <td>8 Outputs 110/127 VAC 1 A</td> </tr> <tr> <td>TSX DST 8 05</td> <td>8 Outputs 110/240 VAC 2 A</td> </tr> <tr> <td>TSX DST 8 17</td> <td>8 Outputs 24/48 VDC 0.5A/Prot.LP</td> </tr> <tr> <td>TSX DST 8 35</td> <td>8 Outputs Rel. Ind. (1A/240VAC)</td> </tr> </tbody> </table>	Code	TSX 7 family name	0	Discrete inputs	1	Discrete outputs	2	Analog inputs	3	Analog outputs	4	Other	Code	Description	TSX DST 4 17	4 Outputs 24/48 VDC 2A/Prot.LP	TSX DST 8 04	8 Outputs 110/127 VAC 1 A	TSX DST 8 05	8 Outputs 110/240 VAC 2 A	TSX DST 8 17	8 Outputs 24/48 VDC 0.5A/Prot.LP	TSX DST 8 35	8 Outputs Rel. Ind. (1A/240VAC)
Code	TSX 7 family name																								
0	Discrete inputs																								
1	Discrete outputs																								
2	Analog inputs																								
3	Analog outputs																								
4	Other																								
Code	Description																								
TSX DST 4 17	4 Outputs 24/48 VDC 2A/Prot.LP																								
TSX DST 8 04	8 Outputs 110/127 VAC 1 A																								
TSX DST 8 05	8 Outputs 110/240 VAC 2 A																								
TSX DST 8 17	8 Outputs 24/48 VDC 0.5A/Prot.LP																								
TSX DST 8 35	8 Outputs Rel. Ind. (1A/240VAC)																								
4	In the Modules catalog select the desired device.																								
5	Click OK to confirm your choice. Result: The Series 7 device is defined in its slot, the device reference appears opposite the slot number.																								
6	To declare other Series 7 devices on the TSX ESY 007 Module, repeat the step 2 procedure.																								

Note: When adding the first device, the following message may appear:



This means that you do not have adequate rights to configure the TSX ESY 007 Module. Contact Schneider Services Industries entities in France, and abroad Schneider Services entities or otherwise their representative.

Displaying the I/O Extension Bus in the Project Browser

At a Glance

When you declare a TSX ESY 007 Module on the PLC rack, the I/O extension bus is shown in the **configuration** folder of the project browser. The extension bus number is automatically calculated by UNITY Pro. **This value cannot be modified.**

After **declaring** all Series 7 devices on the I/O extension bus and **confirming** the configuration, the Series 7 modules also appear on the I/O extension bus of the project browser. Each module appears with its address number. Display of the I/O extension bus and Series 7 devices allows you to quickly know their topological address.

The following illustration shows the LES20 bus with its Series 7 modules in the project browser:

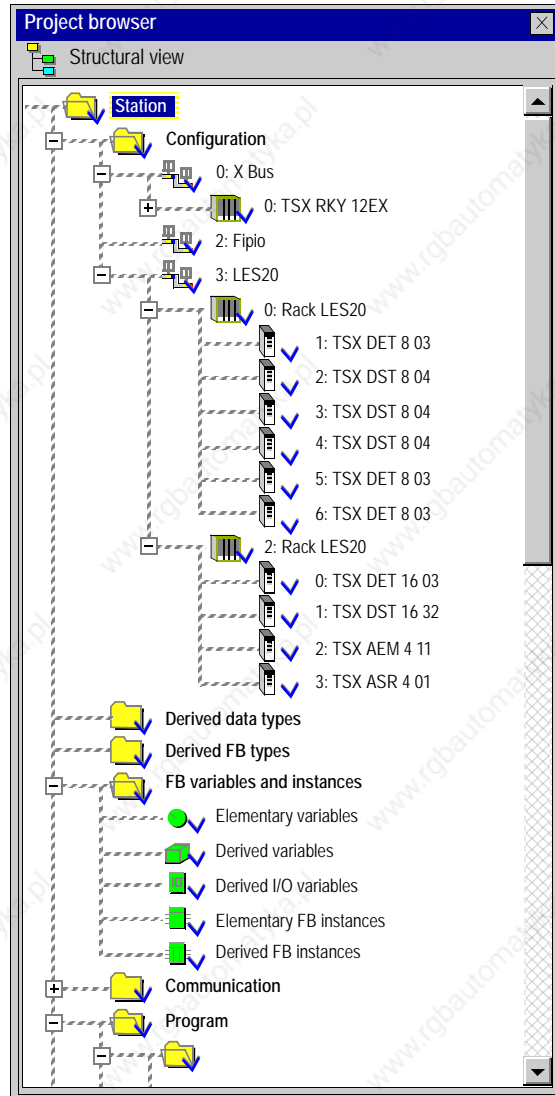

The I/O extension bus is shown by LES20 in the project browser.

Modifying the software configuration of a TSX ESY 007 Module

Introduction

Unity Pro software offers, from the module configuration screen, a range of functions that allow easy modification of the software configuration of the I/O extension bus in offline mode.

Note: Standard Windows keyboard shortcut commands (Del, Ctrl-X, Ctrl-C, Ctrl-V) are also available for the following operations.

Note: The move and copy commands are only available with configuration rights.

Procedure for deleting a Series 7 module

This operation is used to delete a module declared on the I/O extension bus.

Step	Action
1	Select the module to be deleted.
2	Select the Edit> command. Delete a Series 7 module.

Procedure for moving a Series 7 module

This operation is used to move a module declared on the I/O extension bus.

Step	Action
1	Select the module to be moved.
2	Select the Edit> command. Cut a Series 7 module.
3	Select the new slot desired.
4	Select the Edit> command. Paste a Series 7 module.

Procedure for copying a Series 7 module

This operation is used to copy a module declared on the I/O extension bus.

Step	Action
1	Select the module to be copied.
2	Select the Edit> command. Copy a Series 7 module.
3	Select the slot of the new module.
4	Select the Edit> command. Paste a Series 7 module.

Accessing the Description of a Series 7 Module

At a Glance

The UNITY Pro software provides access to all information relating to a Series 7 device, such as:

- description of the module,
- the task for which is configured,
- the list of I/O objects that it controls.

Procedure for accessing device information

The table below shows the procedure for viewing the features of a Series 7 device.

Step	Action
1	Open the TSX ESY 007 Module to be configured.
2	Access the configuration screen by clicking on the Configuration tab.
3	Click on the desired Series 7 device. Results: The right side of the configuration screen shows information about the selected device.

Information

Input/Output symbols

Channel	Address	Symbol
1	%I3.1I0.2.0	
2	%I3.1I0.2.1	
3	%I3.1I0.2.2	
4	%I3.1I0.2.3	
5	%I3.1I0.2.4	
6	%I3.1I0.2.5	
7	%I3.1I0.2.6	
8	%I3.1I0.2.7	
9		
10		
11		
12		
13		
14		
15		
16		
17		
18		
19		
20		

Description: 8 independ. inputs 24 VAC

Task:

Scan duration calculated for the

Mast: ms

Fast: ms

Accessing the Description of a Series 7 Rack.

At a Glance

The UNITY Pro software provides access to all information relating to a Series 7 rack, such as:

- fallback mode,
- type of extension (local/electrical/optical).

Procedure for accessing rack information

The table below shows the procedure for viewing the features of a Series 7 rack.

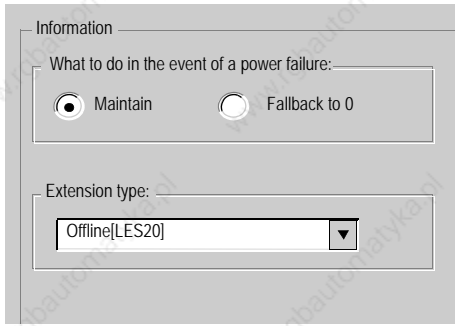
Step	Action
1	Open the TSX ESY 007 Module to be configured.
2	Access the configuration screen by clicking on the Configuration tab.
3	<p>Click on the desired Series 7 rack.</p> <p>Results: The right side of the configuration screen shows information about the selected rack.</p> 

Accessing the Description of a Series 7 Module

At a Glance

Each Series 7 device must have assigned to it (by configuration) a PLC task that is either MAST or FAST.

Procedure

The table below shows the procedure for defining the **Task** parameter.

Step	Action
1	Open the TSX ESY 007 Module to be configured.
2	Access the configuration screen by clicking on the Configuration tab.
3	Click on the device whose Task parameter you wish to modify.
4	In the Task parameter drop-down list select the task that you wish to define for the module.

Modifying General Parameters of a Series 7 Rack

At a Glance

Each Series 7 rack must have assigned to it (by configuration) a fallback mode as well as a type of entrance link.

Procedure

The table below shows the procedure for defining the **Fallback mode** parameter.

Step	Action
1	Open the TSX ESY 007 Module to be configured.
2	Access the configuration screen by clicking on the Configuration tab.
3	Click on the device whose Fallback mode parameter you wish to modify.
4	Select the radio button that corresponds to the type of fallback mode (Maintain/Fallback) that you wish to define for the rack.

Procedure

The table below shows the procedure for defining the **Entrance link** parameter.

Step	Action
1	Open the TSX ESY 007 Module to be configured.
2	Access the configuration screen by clicking on the Configuration tab.
3	Click on the device whose Entrance link type parameter you wish to modify.
4	In the Entrance link type parameter drop-down list select the entrance link type (local, electrical or optical) that you wish to define for the rack.

Debugging the TSX ESY 007 Module

5

At a Glance

Subject of this Chapter

This chapter describes the TSX ESY 007 Module debug feature.

What's in this Chapter?

This chapter contains the following topics:

Topic	Page
The debug function - Presentation	90
Description of the Debug Screen of a TSX ESY 007 Module	91
Accessing TSX ESY 007 Module Diagnostics and Channel Diagnostics Functions	93
Viewing Status of Series 7 Racks and Modules	95
Accessing the Forcing/Unforcing Discrete Channels Function	97
Modifying the Value of an Analog Channel	98

The debug function - Presentation

Introduction

For each TSX ESY 007 communication module in the project the **Debug** function allows:

- display of Series 7 racks (connection, parameters etc.),
- display of status of Series 7 modules (connection, parameters, channel values),

The function also provides access to module diagnostics in the event of a fault.

Note: This function is only accessible in online mode.

Rack viewer

It is also possible to access information about a TSX ESY 007 Module from the **Rack viewer** page of an on board Web FactoryCast server in a TSX ETY 4102 or TSX ETY 5102 module. These Web pages are accessible using an Internet web browser.

Actual ETHERNET couplers are TSX ETY 4103, TSX TEY 5103 or TSX WMY 100 modules. WEB pages are also accessible on the Ethernet ports of the CPUs.

See Ethernet installation manual (See UNITY Pro Premium and Atrium Manual, Ethernet Networks, Installation of Ethernet communication software) and in the FactoryCast Manual for more information.

Description of the Debug Screen of a TSX ESY 007 Module

At a Glance

The debug screen dynamically displays the status of the TSX ESY 007 Module and the devices connected on the bus.

Note: if you use the READ_STS () function in your user program to read information about the TSX ESY 007 Module, you should not execute the function more than once every 5 seconds, otherwise the debug screen will not display properly.

Illustration

The figure below shows a sample debug screen.

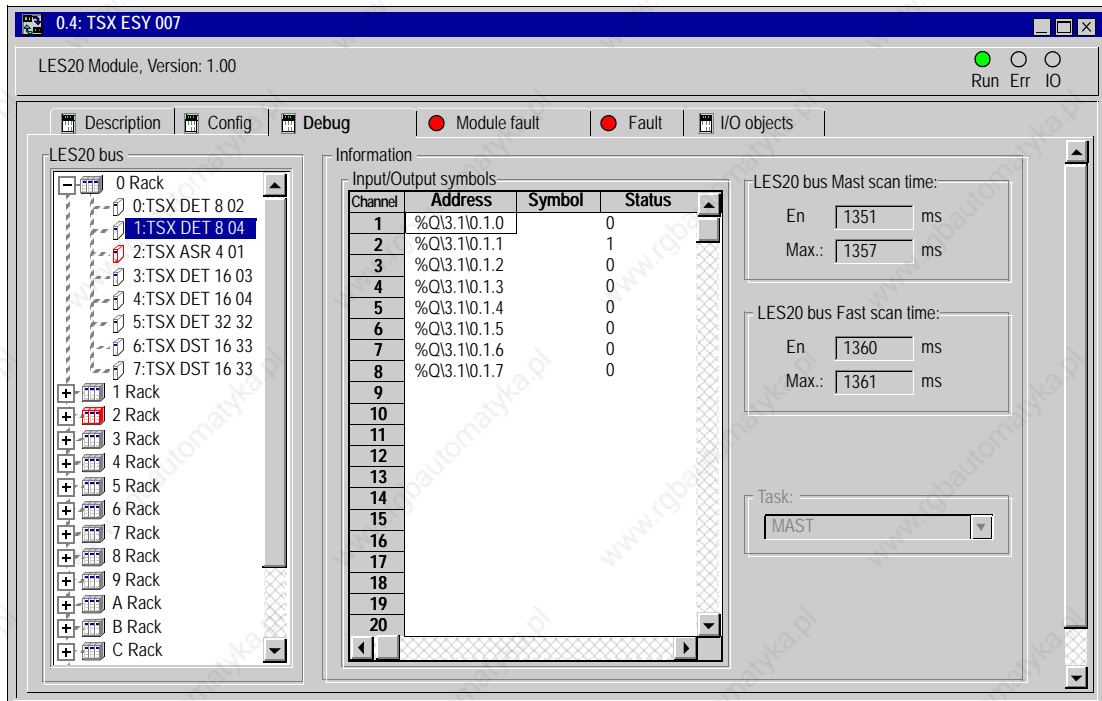

The tab in the foreground indicates the mode in progress (**Debug** in this example). Each mode may be selected using the tab for the mode. The following modes are available:

- **Description**,
- **Debug** only accessible in online mode,
- **Diagnostics** (fault) only accessible in online mode,
- **Configuration**.

The **I/O objects** tab (See UNITY Pro Manual, Operation Modes, Module I/O Objects Tab) allows to presymbolize I/O objects.

The debug screen allows you to view the following features:

- The behavior type of the Series 7 rack in fallback mode,
- The entrance link type of the Series 7 rack (local, electrical or optical),
- The task controlling a Series 7 module,
- The I/O objects of a Series 7 module and their values,
- The current and maximum scan times of the I/O extension bus in milliseconds for MAST and FAST tasks,
- Faults present on the Series 7 modules and racks.

In the upper area are 3 LED indicators which indicate the operating mode of the module

- **RUN** indicates the operating status of the module,
 - **ERR** indicates an internal module fault,
 - **I/O** indicates an input/output fault on the I/O extension bus.
-

Accessing TSX ESY 007 Module Diagnostics and Channel Diagnostics Functions

At a Glance

The module and channel diagnostics are displayed, when current errors exist, and are classed according to their category:

- internal faults (software internal fault, communication failure with processor, configuration or parameter fault, or command fault),
- external faults (Series 7 device fault),
- other faults (module absent or power off).

A module or channel fault is signaled when some LED indicators turn red, such as:

- in the rack configuration screen, a red square in the place of the faulty I/O entrance link module,
- in all module level screens (**Description** and **Fault** tabs), the presence of the **I/O** LED indicator,
- in all channel level screens (**Description**, **Config**, **Debug** and **Fault** tabs), the presence of the **I/O** LED indicator and the channel fault LED indicator,
- in the fault screen accessible by the **Fault** tab, the fault diagnostics description.

The fault is also signaled:

- on the module, on the central display,
 - by dedicated language objects: **CH_ERROR** (%lr.m.c.ERR) and module error **MOD_ERROR** (%lr.m.MOD.ERR), **%MWr.m.MOD.2**, etc., and the status words (See T_GEN_MOD-type IODDT Language Objects, Chapter 7.4).
-

Procedure for accessing module diagnostics

The following table shows the procedure for accessing the **Diagnostics** screen for the module and the LES20 channel.

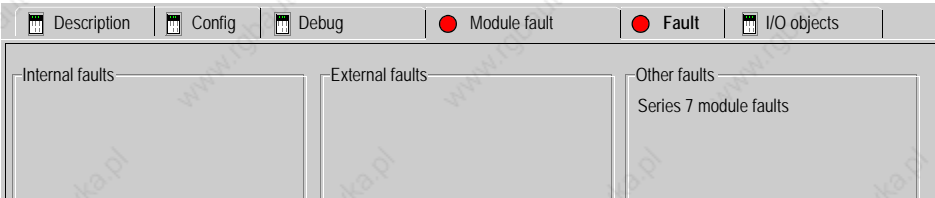
Step	Action
1	Open the TSX ESY 007 Module that you would like to diagnose.
2	<p>Access the diagnostics screen by clicking on the Fault tab.</p> <p>Results: The list of module faults is displayed.</p> 

Viewing Status of Series 7 Racks and Modules

At a Glance

The left side of the TSX ESY 007 Module debug screen is reserved for I/O extension bus diagnostics.

Series 7 devices connected to the bus may be viewed in the LES20 bus area. Each Series 7 device and rack is colored in red or gray according to its status. Red indicates a failure on the rack or module concerned. When a module is selected, the I/O list of the module is displayed with the corresponding values.

Display status of Series 7 modules and racks

Illustration :

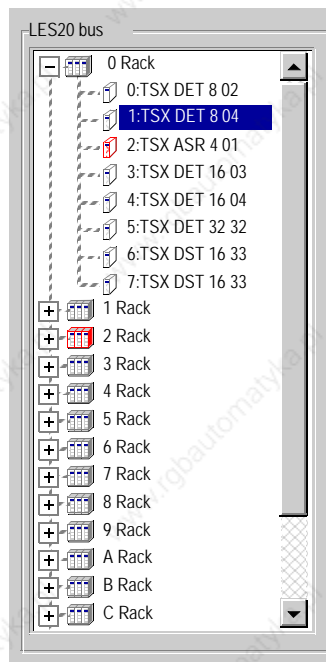

Display of Channel Status of a Series 7 Module

Illustration :

Channel	Address	Symbol	Status
1	%Q43.140.1.0		1
2	%Q43.140.1.1		0
3	%Q43.140.1.2		0
4	%Q43.140.1.3		0
5	%Q43.140.1.4		0
6	%Q43.140.1.5		0
7	%Q43.140.1.6		0
8	%Q43.140.1.7		0
9			
10			

Note: The 32-channel modules being represented as two 16-channel modules in the same slot in the even rack and the next odd rack, for displaying the states of channels 16 to 31 of these modules (TSX DET 32 xx, TSX DST 24 xx, TSX DST 32 xx), you must click on the slot marked "reserved" of the odd rack.

Accessing the Forcing/Unforcing Discrete Channels Function

At a Glance

This function allows modification of the status of the channels associated with a Series 7 module.

The different commands available are:
for a channel:

- forcing to 0,
- forcing to 1,
- unforcing,
- positioning to 0 (Discrete outputs only),
- positioning to 1 (Discrete outputs only).

Procedure

The table below shows the procedure for forcing, unforcing or positioning channels associated with the features of Series 7 module.

Step	Action
1	Open the I/O entrance link module on which you wish to modify a channel.
2	Access the diagnostics screen by clicking on the Debug tab.
3	Select a module in the LES20 bus area.
4	Note the channel to modify in the I/O list of the module.
5	Opening an animation table.
6	Enter the name of the channel to modify.
7	Select the desired function (Modify, Forcing).
8	Modify the value of the channel based on available functions (set to 0, set to 1, forcing to 0, forcing to 1, unforcing).

The screenshot shows a software interface for channel modification. At the top, there is a blue header bar with the word 'Table'. Below it is a toolbar with a 'Modification' button (selected) and a 'Force' button. To the right of these buttons are several icons for channel manipulation. Below the toolbar is a table with the following data:

Name	Value	Type	Comment
%q3.110.1.0	1	EBOOL	
%q3.110.3.0	0	EBOOL	
%q3.110.5.0	0	EBOOL	
%q3.110.7.0	0	EBOOL	
%q3.110.0.0	F1	EBOOL	

Modifying the Value of an Analog Channel

At a Glance

This function allows you to modify the value of channels associated with a Series 7 module that has analog-type channels.

This function applies only to analog outputs.

Procedure

The table below shows the procedure for modifying analog channels associated with the features of Series 7 module.

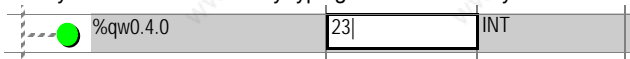
Step	Action
1	Open the I/O entrance link module you wish to configure.
2	Access the diagnostics screen by clicking on the Debug tab.
3	Select a module in the I/O extension bus area.
4	Note the channel to modify in the I/O list of the module.
5	Opening an animation table.
6	Enter the name of the channel to modify.
7	Select the Modify function.
8	Modify the channel's value by typing the value directly into the value field and confirm pressing Enter. 

Performance of the TSX ESY 007 Module

6

Performance of the TSX ESY 007 Module

Introduction

The I/O extension bus is autonomously managed by the TSX ESY 007 Module, which exchanges data with each Series 7 device configured on the bus every cycle.

For Series 7 modules configured in the MAST task, the scan cycle on the I/O extension bus is cadenced by the MAST task of the PLC.

I/O extension bus scan time

The maximum scan time t represents the exchange time between the master and the Series 7 n models (128 maximum). The t and t_{max} values depend on the number and types of Series 7 modules to control.

Either:

- $t = 0.192\text{ms} \times \text{Number of 4-channel discrete modules} + 0.228\text{ms} \times \text{Number of 8-channel discrete modules} + 0.300\text{ms} \times \text{Number of 16-channel discrete modules} + 1.900\text{ms} \times \text{Number of ANA/Analog modules} + 7.3 \text{ ms}$
- $t_{max} = 0.200\text{ms} \times \text{Number of 4-channel discrete modules} + 0.250\text{ms} \times \text{Number of 8-channel discrete modules} + 0.350\text{ms} \times \text{Number of 16-channel discrete modules} + 2.0\text{ms} \times \text{Number of ANA/Analog modules} + 7.3 \text{ ms}$

Thus the scan time can not exceed 110 ms.

I/O extension bus response time

The response time T represents the I/O extension bus scan time.

This latter includes the following:

- bus scan time,
 - internal memory update of the TSX ESY 007 Module,
 - the PLC scan.
-

Example

The table below shows three examples of response time T for a PLC task of 10 ms, 30 ms, 60 ms.

This time T lengthens with a bus loaded with 128 16-channel discrete modules in the Mast task normally functioning without link fault.

PLC Task	Typical response time	Maximum response time
10 ms	35 ms	45 ms
30 ms	55 ms	65 ms
60 ms	85 ms	95 ms

Language Objects of the TSX ESY 007 Module

7

At a Glance

Subject of this Chapter

This chapter describes the language objects associated with the TSX ESY 007 Module, along with their different uses.

What's in this Chapter?

This chapter contains the following sections:

Section	Topic	Page
7.1	Language Objects and IODDT of TSX ESY 007 Module Communications	102
7.2	General Language Objects and IODDT for All Communication Protocols	110
7.3	Language Objects and IODDT Associated with the TSX ESY 007 Module	114
7.4	The T_GEN_MOD IODDT Applicable to All Modules	123

7.1 Language Objects and IODDT of TSX ESY 007 Module Communications

At a Glance

Subject of This Section

This section presents general information about language objects and IODDT associated with I/O extension bus.

What's in this Section?

This section contains the following topics:

Topic	Page
TSX ESY 007 Module Language Objects - Presentation	103
Implicit Exchange Language Objects Associated With an Application-specific Function	104
Explicit Language Objects Associated With an Application-specific Function	105
Management of the exchange and report with explicit objects	107

TSX ESY 007 Module Language Objects - Presentation

General Points

IODDT are predefined by the manufacturer, and contain input/output language objects belonging to an application-specific module.

The TSX ESY 007 Module has two associated IODDT:

- T_COM_STS_GEN which applies to all communication protocols,
- T_COM_ESY specific to the TSX ESY 007 Module.

Note : IODDT variables can be created in two different ways:

- the **I/O objects** tab (see UNITY Pro Manual, Operation Modes, Module I/O Objects Tab),
- data editor (see UNITY Pro Manual, Operation Modes, Creating an IODDT data instance).

Language object types

Each IODDT includes a series of language objects used to drive and monitor their operation.

There are two types of language objects:

- **implicit exchange objects**, which are automatically exchanged on each scan of the task associated with the module,
- **explicit exchange objects**, which are exchanged when requested to do so by the project, using explicit exchange instructions.

Implicit exchange objects allow retrieval of Series 7 module status, LESBUS scan times, etc.

Explicit exchanges allow module diagnostics.

Implicit Exchange Language Objects Associated With an Application-specific Function

At a Glance

An integrated application-specific interface or the addition of a module automatically enhances the language objects application used to program this interface or module.

These objects correspond to the input/output images and software data of the module or integrated application-specific interface.

Reminders

The module inputs (%I and %IW) are updated in the PLC memory at the start of the task, the PLC being in RUN or STOP mode.

The outputs (%Q and %QW) are updated at the end of the task, only when the PLC is in RUN mode.

Note: When the task is in STOP mode, outputs are maintained at their last value.

Illustration

The following diagram shows the operating cycle of a PLC task (scan execution).

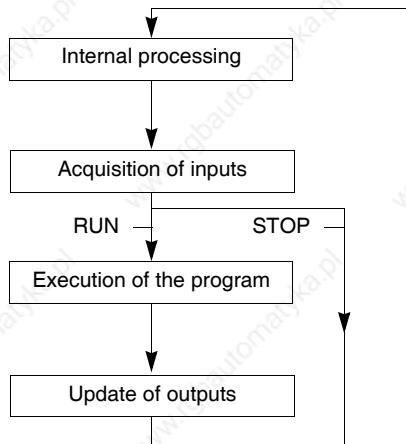

Explicit Language Objects Associated With an Application-specific Function

At a Glance

Explicit exchanges are exchanges performed at the program user request using the following instructions:

- READ_STS (See Unity Pro, I/O Management Manual, READ_STS) (read status words),
- WRITE_CMD (See Unity Pro, I/O Management Manual, WRITE_CMD) (write command words),
- WRITE_PARAM (See Unity Pro, I/O Management Manual, WRITE_PARAM) (write adjustment parameters),
- READ_PARAM (See Unity Pro, I/O Management Manual, READ_PARAM) (read adjustment parameters),
- SAVE_PARAM (See Unity Pro, I/O Management Manual, SAVE_PARAM) (save adjustment parameters),
- RESTORE_PARAM (See Unity Pro, I/O Management Manual, RESTORE_PARAM) (restore adjustment parameters).

These exchanges apply to a set of %MW objects of the same type (status, commands or parameters) that belong to a channel.

Note: These objects provide information about the module (e.g.: type of channel fault, etc.), can be used to command them (e.g.: switch command) and to define their operating modes (save and restore adjustment parameters in the process of application).

General principle for using explicit instructions

The diagram below shows the different types of explicit exchanges that can be made between the processor and module.

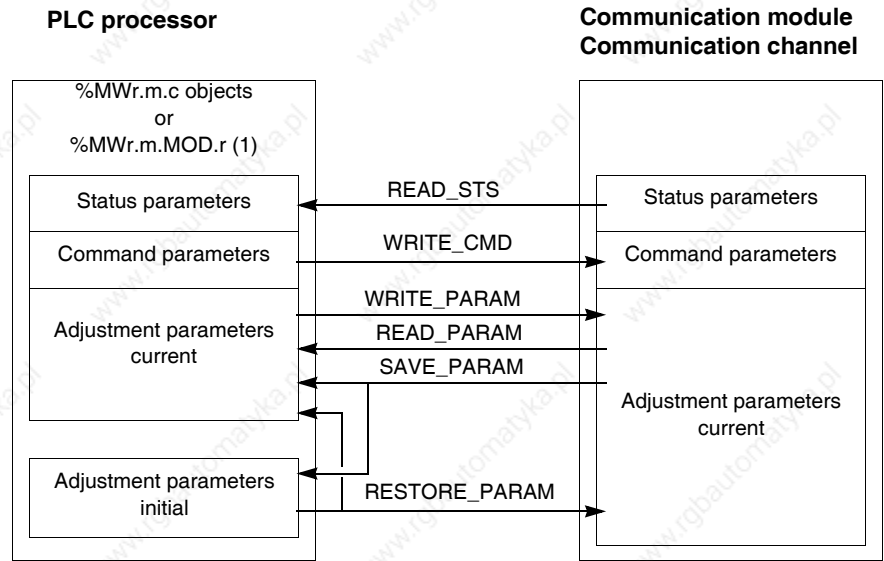

(1) Only with the instructions READ_STS and WRITE_CMD.

Managing exchanges

During an explicit exchange, it is necessary to check its performance in order that data is only taken into account when the exchange has been correctly executed.

To do this, two types of information are available:

- information concerning the exchange in progress (See Unity Pro, I/O Management Manual, Explicit Exchange Report: EXCH_RPT),
- the exchange report (see Unity Pro, I/O Management Manual, Execution Indicators for an Explicit Exchange: EXCH_STS).

The following diagram describes the management principle for an exchange



Management of the exchange and report with explicit objects

At a Glance

When data is exchanged between the PCL memory and the module, the module may require several task cycles to acknowledge this information. All IODDTs use two words to manage exchanges:

- EXCH_STS (%MWr.m.c.0): exchange in progress,
- EXCH_RPT (%MWr.m.c.1): report.

Illustration

The illustration below shows the different significant bits for managing exchanges:

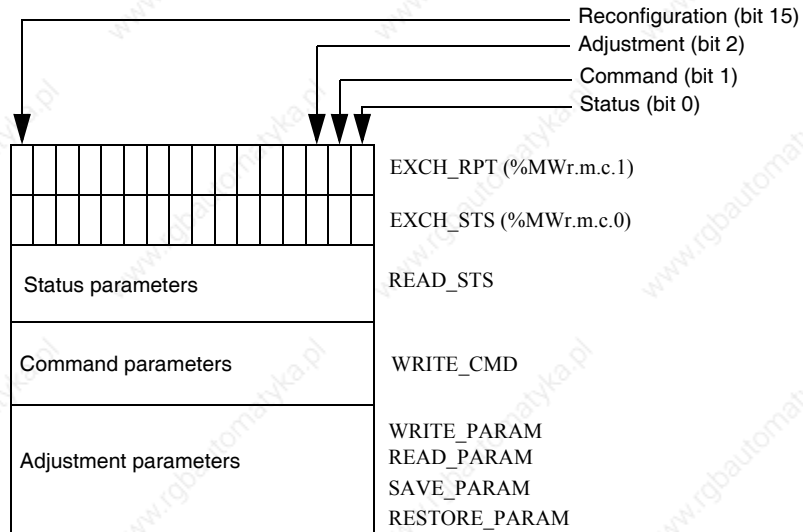

Description of significant bits

Each bit of the words EXCH_STS (%MWr.m.c.0) and EXCH_RPT (%MWr.m.c.1) is associated with a type of parameter:

- Rank 0 bits are associated with the status parameters:
 - the STS_IN_PROGR bit (%MWr.m.c.0.0) indicates whether a read request for the status words is in progress,
 - the STS_ERR bit (%MWr.m.c.1.0) specifies whether a read request for the status words is accepted by the module channel.
- Rank 1 bits are associated with the command parameters:
 - the CMD_IN_PROGR bit (%MWr.m.c.0.1) indicates whether command parameters are being sent to the module channel,
 - the CMD_ERR bit (%MWr.m.c.1.1) specifies whether the command parameters are accepted by the module channel.
- Rank 2 bits are associated with the adjustment parameters:
 - the ADJ_IN_PROGR bit (%MWr.m.c.0.2) indicates whether the adjustment parameters are being exchanged with the module channel (via WRITE_PARAM, READ_PARAM, SAVE_PARAM, RESTORE_PARAM),
 - the ADJ_ERR bit (%MWr.m.c.1.2) specifies whether the adjustment parameters are accepted by the module. If the exchange is correctly executed, the bit is set to 0.
- rank 15 bits indicate a reconfiguration on channel c of the module from the console (modification of the configuration parameters + cold start-up of the channel).

Note: The TSX ESY 007 Module only supports the exchange instruction READ_STS.

Note: r represents the rack number and m the position of the module in the rack, while c represents the channel number in the module.

Note: Exchange and report words also exist at module level EXCH_STS (%MWr.m.MOD) and EXCH_RPT (%MWr.m.MOD.1) as per IODDT type T_GEN_MOD.

**Execution flags
of an explicit
exchange:
EXCH_STS**

The table below shows the control bits of the explicit exchanges: EXCH_STS (%MWr.m.c.0).

Standard symbol	Type	Access	Meaning	Address
STS_IN_PROGR	BOOL	R	Reading of channel status words in progress	%MWr.m.c.0.0
CMD_IN_PROGR	BOOL	R	Command parameters exchange in progress	%MWr.m.c.0.1
ADJ_IN_PROGR	BOOL	R	Adjustment parameters exchange in progress	%MWr.m.c.0.2
RECONF_IN_PROGR	BOOL	R	Reconfiguration of the module in progress	%MWr.m.c.0.15

Note: If the module is not present or is disconnected, explicit exchange objects (Read_Sts for example) are not sent to the module (STS_IN_PROG (%MWr.m.c.0) = 0).

**Explicit
exchange report:
EXCH_RPT**

The table below shows the report bits: EXCH_RPT (%MWr.m.c.1).

Standard symbol	Type	Access	Meaning	Address
STS_ERR	BOOL	R	Error reading channel status words (1 = failure)	%MWr.m.c.1.0
CMD_ERR	BOOL	R	Error when exchanging command parameters (1 = failure)	%MWr.m.c.1.1
ADJ_ERR	BOOL	R	Error when exchanging adjustment parameters (1 = failure)	%MWr.m.c.1.2
RECONF_ERR	BOOL	R	Fault when reconfiguring the channel (1 = failure)	%MWr.m.c.1.15

R: Read access only W: Write access only R/W: Read/Write access

7.2 General Language Objects and IODDT for All Communication Protocols

At a Glance

Subject of This Section

This section presents the general language objects and IODDT that apply to all communication protocols.

What's in this Section?

This section contains the following topics:

Topic	Page
Implicit Exchange Objects of the T_COM_STS_GEN-type IODDT - Details	111
T_COM_STS_GEN-type IODDT Explicit Exchange Objects - Details	112

Implicit Exchange Objects of the T_COM_STS_GEN-type IODDT - Details

At a Glance

The table below presents the IODDT implicit exchange objects of type T_COM_STS_GEN applicable to all communication protocols except Fipio.

Error bit

Meaning of the CH_ERROR (%r.m.c.ERR) error bit.

Standard symbol	Type	Access	Meaning	Address
CH_ERROR	EBOOL	R	Communication channel error bit.	%r.m.c.ERR

T_COM_STS_GEN-type IODDT Explicit Exchange Objects - Details

At a Glance

This section presents the T_COM_STS_GEN type IODDT explicit exchange objects applicable to all communication protocols except Fipio. It includes the word type objects whose bits have a specific meaning. These objects are presented in detail below.

Example of a declaration of a variable: **IODDT_VAR1** of type T_COM_STS_GEN.

Observations

- In general, the meaning of the bits is given for bit status 1. In specific cases an explanation is given for each status of the bit.
- Not all bits are used.

Execution flags of an explicit exchange: EXCH_STS

The following table explains the various meanings of EXCH_STS (%MWr.m.c.0) channel exchange control bits.

Standard symbol	Type	Access	Meaning	Address
STS_IN_PROGR	BOOL	R	Reading of channel status words in progress.	%MWr.m.c.0.0
CMD_IN_PROGR	BOOL	R	Current parameter exchange in progress.	%MWr.m.c.0.1
ADJ_IN_PROGR	BOOL	R	Adjustment parameter exchange in progress.	%MWr.m.c.0.2

Explicit Exchange Report: EXCH_RPT

The following table explains the various meanings of EXCH_RPT (%MWr.m.c.1) reporting bits.

Standard symbol	Type	Access	Meaning	Address
STS_ERR	BOOL	R	Reading error for channel status words.	%MWr.m.c.1.0
CMD_ERR	BOOL	R	Error during command parameter exchange.	%MWr.m.c.1.1
ADJ_ERR	BOOL	R	Error during adjustment parameter exchange.	%MWr.m.c.1.2

Standard channel faults, CH_FLT

The table below shows the meaning of the bits of the status word CH_FLT (%MWr.m.c.2). Reading is performed by a **READ_STS(IODDT_VAR1)**.

Standard symbol	Type	Access	Meaning	Address
NO_DEVICE	BOOL	R	No device is working on the channel.	%MWr.m.c.2.0
1_DEVICE_FLT	BOOL	R	A device on the channel is faulty.	%MWr.m.c.2.1

Standard symbol	Type	Access	Meaning	Address
BLK	BOOL	R	Terminal block fault (not connected).	%MWr.m.c.2.2
TO_ERR	BOOL	R	Time out error (defective wiring).	%MWr.m.c.2.3
INTERNAL_FLT	BOOL	R	Internal error or channel self-test.	%MWr.m.c.2.4
CONF_FLT	BOOL	R	Different hardware and software configurations.	%MWr.m.c.2.5
COM_FLT	BOOL	R	Problem communicating with the PLC.	%MWr.m.c.2.6
APPLI_FLT	BOOL	R	Application error (adjustment or configuration error).	%MWr.m.c.2.7

7.3 Language Objects and IODDT Associated with the TSX ESY 007 Module

At a Glance

Subject of This Section

This section presents the language objects and IODDT associated with the TSX ESY 007 Module.

What's in this Section?

This section contains the following topics:

Topic	Page
Details of the implicit exchange objects of the IODDT of the T_COM_ESY type	115
Details of the T_COM_ESY-type IODDT Explicit Exchange Objects	119
Implicit Exchange Objects of the TSX ESY 007 Module - Details	120
Configuration Objects for the TSX ESY 007 Module - Details	122

Details of the implicit exchange objects of the IODDT of the T_COM_ESY type

At a Glance

The following tables present the T_COM_ESY-type IODDT implicit exchange objects that apply to the TSX ESY 007 Module.

Error bit

The following table presents the meaning of the error bit CH_ERROR (%I.r.m.0.ERR).

Standard symbol	Type	Access	Meaning	Address
CH_ERROR	EBOOL	R	Communication channel error bit.	%I.r.m.0.ERR r.m: slot of the TSX ESY 007 Module in the Premium rack

Validation bit

The following table presents the meaning of the validation bit VALID_IN (%I.r.m.0.0).

Standard symbol	Type	Access	Meaning	Address
VALID_IN	EBOOL	R	Indicates that all inputs are valid. Note: when this bit has status 0, it means that at least one input is not valid: The module is in auto-test, initialization or fault.	%I.r.m.0.0 r.m: slot of the TSX ESY 007 Module in the Premium rack

List of racks 0 to 15 in fault The following table presents the meaning of the bits of the word (%IW.r.m.c.0).

Standard symbol	Type	Access	Meaning	Address
LES20_FLT_RACKS	INT	R	Rack 0 to F faulty or absent.	%IW.r.m.c.0
LES20_FLT_0	BOOL	R	0 Rack faulty or absent.	%IW.r.m.c.0.0
LES20_FLT_1	BOOL	R	1 Rack faulty or absent.	%IW.r.m.c.0.1
LES20_FLT_2	BOOL	R	2 Rack faulty or absent.	%IW.r.m.c.0.2
LES20_FLT_3	BOOL	R	3 Rack faulty or absent.	%IW.r.m.c.0.3
LES20_FLT_4	BOOL	R	4 Rack faulty or absent.	%IW.r.m.c.0.4
LES20_FLT_5	BOOL	R	5 Rack faulty or absent.	%IW.r.m.c.0.5
LES20_FLT_6	BOOL	R	6 Rack faulty or absent.	%IW.r.m.c.0.6
LES20_FLT_7	BOOL	R	7 Rack faulty or absent.	%IW.r.m.c.0.7
LES20_FLT_8	BOOL	R	8 Rack faulty or absent.	%IW.r.m.c.0.8
LES20_FLT_9	BOOL	R	9 Rack faulty or absent.	%IW.r.m.c.0.9
LES20_FLT_10	BOOL	R	A Rack faulty or absent.	%IW.r.m.c.0.10
LES20_FLT_11	BOOL	R	B Rack faulty or absent.	%IW.r.m.c.0.11
LES20_FLT_12	BOOL	R	C Rack faulty or absent.	%IW.r.m.c.0.12
LES20_FLT_13	BOOL	R	D Rack faulty or absent.	%IW.r.m.c.0.13
LES20_FLT_14	BOOL	R	E Rack faulty or absent.	%IW.r.m.c.0.14
LES20_FLT_15	BOOL	R	F Rack faulty or absent.	%IW.r.m.c.0.15

I/O extension bus scan time value The following table shows the meaning of the words (%Iwr.m.c.1 to 4) and of the bit (%QWr.m.c.0).

Standard symbol	Type	Access	Meaning	Address
CLEAR_LES20_DISPLAY_CYCLE_TIME	BOOL	W/R	reset to 0 the LES20 scan time.	%QWr.m.c.0.0
LES20_CUR	INT	R	LES20 MAST scan time (in ms).	%IW.r.m.c.1
LES20_MAX	INT	R	LES20 MAST maximum scan time (in ms).	%IW.r.m.c.2
LES20_CUR_FAST	INT	R	LES20 FAST scan time (in ms).	%IW.r.m.c.3
LES20_MAX_FAST	INT	R	LES20 FAST maximum scan time (in ms).	%IW.r.m.c.4

Optimization of the I/O extension bus scan time value

The following table presents the meaning of the bit (%QWr.m.c.0.1).

Standard symbol	Type	Access	Meaning	Address
OPTIMIZE_LES20_SYNCHRO_CYCLE_TIME	BOOL	W/R	Activation of a waiting time between positioning the outputs and reading the inputs on the I/O extension bus. The value of the waiting time is encoded on the most significant byte of %QWr.m.c.0 (bits 8 to 15).	%QWr.m.c.0.1

This option is used to approach the operation of the TSX Series 7 CPUs.

Without this option, the principle of exchanging I/Os with the Series 7 module is the following:

- tabulation of outputs on the X Bus by the Premium CPU sent to ESY 007,
- tabulation of outputs on the LES20 Bus by the ESY sent to the TSX Series 7 modules,
- recovery by the ESY 007 of TSX Series 7 module inputs on the LES20 bus,
- wait for the end of the task period of the Premium CPU,
- recovery of inputs on the X Bus by the Premium CPU from the ESY 007,
- normal execution of the application program.

With this option, the principle of exchanging I/Os with the Series 7 module is the following:

- tabulation of outputs on the X Bus by the Premium CPU sent to ESY 007,
- tabulation of outputs on the LES20 Bus by the ESY sent to the TSX Series 7 modules,
- waiting period $\%QWr.m.c.8 \text{ to } 15 = (\%SW0 - \%SW30 - LES20_CUR) \times 0.8$,
- recovery by the ESY 007 of TSX Series 7 module inputs on the LES20 bus,
- wait for the end of the task period of the Premium CPU,
- recovery of inputs on the X Bus by the Premium CPU from the ESY 007,
- normal execution of the application program.

This option allows to respect a waiting time between the positioning of the outputs on the LES20 Bus and the recovery of the inputs. This waiting period is defined by the user. It is encoded on the most significant bit of the word %QWr.m.c.0 and will respect the following formula: $(\%SW0 - \%SW30 - LES20_CUR) \times 0.8$.

Example: For a periodic cycle time set at 100 ms with an average execution time of 40 ms and a LES20 bus cycle time of 30 ms, the wait time will be set at $(100 - 40 - 30) \times 0.8 = 24$ ms. In this case the value of the word %QWr.m.0 of the ESY 007 will be 16#1802 (most significant bit of the 24 decimal word and least significant with bit 1 at 1 for wait activation).

Note: This option should be avoided when making intensive use of messaging with the TSX Series 7 modules by EF SEND_REQ. However, it is possible to modify the coefficient (0.8) in order to improve request handling, when requests exist.

Details of the T_COM_ESY-type IODDT Explicit Exchange Objects

At a Glance

This section shows the explicit exchange objects of the IODDT of type T_COM_ESY_ESY that applies to the TSX ESY 007 Module. It includes word objects whose bits have a special meaning. These objects are described in detail below.

Sample variable declaration: **IODDT_VAR1** de type T_COM_ESY

Observations

- In general, the meaning of the bits is given for bit status 1. In specific cases an explanation is given for each status of the bit.
- Not all bits are used.

Execution flags of an explicit exchange: EXCH_STS

The table below shows the meaning of channel exchange control bits from channel EXCH_STS (%MWr.m.c.0).

Standard symbol	Type	Access	Meaning	Address
STS_IN_PROGR	BOOL	R	Reading of channel status words in progress.	%MWr.m.c.0.0
CMD_IN_PROGR	BOOL	R	Current parameter exchange in progress.	%MWr.m.c.0.1
ADJ_IN_PROGR	BOOL	R	Adjustment parameter exchange in progress.	%MWr.m.c.0.2

Note: When the explicit exchange has a duration less than the scan time of the PLC task, the %MWr.m.c.0.0 but is never set to 1.

Explicit exchange report: EXCH_RPT

The table below presents the meaning of the exchange report bits EXCH_RPT (%MWr.m.c.1).

Standard symbol	Type	Access	Meaning	Address
STS_ERR	BOOL	R	Reading error for channel status words.	%MWr.m.c.1.0
CMD_ERR	BOOL	R	Error during command parameter exchange.	%MWr.m.c.1.1
ADJ_ERR	BOOL	R	Error during adjustment parameter exchange.	%MWr.m.c.1.2

Implicit Exchange Objects of the TSX ESY 007 Module - Details

At a Glance

The table below shows the different implicit exchange word objects. These objects are not integrated in the T_COM_ESY_007-type IODDT.

Discrete input channel bits

The table below shows the meaning of the Discrete input channel bits.

Address	Type	Access	Meaning
%Ib.1r.m.c	EBOOL	R	Indicates that the input channel (c = 0 to 15) of the Series 7 module (m=0 to 7) of the rack (r=0 to 15) is activated.

Discrete output channel bits

The table below shows the meaning of the Discrete output channel bits.

Address	Type	Access	Meaning
%Qb.1r.m.c	EBOOL	R/W	Indicates that the output channel (c = 0 to 15) of the Series 7 module (m=0 to 7) of the rack (r=0 to 15) is activated.

Analog input channel bits

The table below shows the meaning of the analog input channel word bits.

Address	Type	Access	Meaning
%IWb.1r.m.c	INT	R	Indicates that the input channel (c = 0 to 15) of the Series 7 module (m=0 to 7) of the rack (r=0 to 15) is activated.

Analog output channel bits

The table below shows the meaning of the analog output channel word bits.

Address	Type	Access	Meaning
%QWb.1r.m.c	INT	R/W	Indicates that the output channel (c = 0 to 15) of the Series 7 module (m=0 to 7) of the rack (r=0 to 15) is activated.
%QWr.m.c.0.0	BOOL	R/W	Setting this bit to 1 (Set to 1) allows Set to 0 of calculation values of current and maximum I/O extension bus scan time for the MAST and FAST.

Series 7 module error bit The table below shows the meaning of the error bits of Series 7 modules.

Address	Type	Access	Meaning
%Ib.1\r.m.0.ERR	EBOOL	R	Indicates whether the Series 7 module (m=0 to 7) of the rack (r=0 to 15) is in fault mode.

Configuration Objects for the TSX ESY 007 Module - Details

At a Glance

%KWr.m.c.d configuration constants are accessible only in read mode and correspond to configuration parameters entered using the configuration editor.

Configuration objects

The table below shows the I/O extension bus constants-type objects.

Number	Type	Access	Meaning
%KWr.m.c.0.n	BOOL	R	n = 0 to 15 -> respectively the fallback type (0=fallback to 0, 1=maintain)
%KWr.m.c.1.n	BOOL	R	n = 0 to 15 -> respectively the type of entrance link (0=local, 1=electrical/optical)

7.4 The T_GEN_MOD IODDT Applicable to All Modules

Details of the Language Objects of the IODDT of Type T_GEN_MOD

At a Glance All the modules of Premium PLCs have an associated IODDT of type T_GEN_MOD.

Observations

- In general, the meaning of the bits is given for bit status 1. In specific cases an explanation is given for each status of the bit.
- Not all bits are used.

List of Objects The table below presents the objects of the IODDT:

Standard symbol	Type	Access	Meaning	Address
MOD_ERROR	BOOL	R	Module error bit	%I.r.m.MOD.ERR
EXCH_STS	INT	R	Module exchange control word.	%MWr.m.MOD.0
STS_IN_PROGR	BOOL	R	Reading of status words of the module in progress.	%MWr.m.MOD.0.0
EXCH_RPT	INT	R	Exchange report word.	%MWr.m.MOD.1
STS_ERR	BOOL	R	Fault when reading module status words.	%MWr.m.MOD.1.0
MOD_FLT	INT	R	Internal error word of the module.	%MWr.m.MOD.2
MOD_FAIL	BOOL	R	Internal error, module failure.	%MWr.m.MOD.2.0
CH_FLT	BOOL	R	Faulty channel(s).	%MWr.m.MOD.2.1
BLK	BOOL	R	Terminal block fault.	%MWr.m.MOD.2.2
CONF_FLT	BOOL	R	Hardware or software configuration fault.	%MWr.m.MOD.2.5
NO_MOD	BOOL	R	Module missing or inoperative.	%MWr.m.MOD.2.6
EXT_MOD_FLT	BOOL	R	Internal error word of the module (Fipio extension only).	%MWr.m.MOD.2.7
MOD_FAIL_EXT	BOOL	R	Internal fault, module unserviceable (Fipio extension only).	%MWr.m.MOD.2.8
CH_FLT_EXT	BOOL	R	Faulty channel(s) (Fipio extension only).	%MWr.m.MOD.2.9
BLK_EXT	BOOL	R	Terminal block fault (Fipio extension only).	%MWr.m.MOD.2.10
CONF_FLT_EXT	BOOL	R	Hardware or software configuration fault (Fipio extension only).	%MWr.m.MOD.2.13
NO_MOD_EXT	BOOL	R	Module missing or inoperative (Fipio extension only).	%MWr.m.MOD.2.14

Index

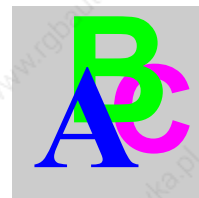

A

Adding a Series 7 Module, 79
Addressing, 21, 53, 63
Analog Value Modification, 98

C

Commands, 60, 76, 79, 84, 97, 105, 107
Configuring Series 7 Modules, 65
Connect I/O extension bus, 30
Connecting the I/O extension bus, 53
Connection, 30

D

Debug, 58, 77, 89, 90, 91, 95
Diagnostics
 I/O Extension Bus, 95
 I/O extension bus, 50
 TSX ESY 007, 90, 93
Display, 90

E

Entrance Link, 45, 88
Entrance link, 17, 21, 39
External defaults, 27
External Faults, 91, 93

F

Fallback, 51, 88
Forcing, 97

I

I/O Extension Bus, 21
I/O Extension bus, 30
I/O extension bus, 15, 17, 20, 58
I/O extension bus components, 17
Installation, 39, 58
Internal defaults, 32
Internal Faults, 91, 93
IODDT, 114, 123
 Communication, 102, 110
 Overview, 103

L

Language Objects, 101, 114
 Communication, 102
 Explicit Exchange, 105, 112, 119
 Implicit Exchange, 104, 111, 120
Language objects
 Explicit exchange, 103
 Implicit exchange, 103, 115
 Management of exchanges, 107
 Overview, 103
LED indicator lights, 50
LED indicators, 32, 33

M

Maintenance, 51
Mode of Operation, 65
Mounting, 28

O

Operating Mode, 51, 91

P

Parameter Modification, 88
Parameters, 77, 88, 105, 107, 122
Performance, 99
Physical presentation, 27
Precautions, 53
Project Browser, 82

S

Safety equipment, 36
Series 7 Insertion Module, 30
Series 7 Module Status, 95
Series 7 Rack Status, 95
Status indicator lights, 27

T

T_COM_ESY, 119
T_COM_ESY_007, 115
T_COM_STS_GEN, 111, 112
T_GEN_MOD, 123
Technical features
 I/O extension bus, 34
 TSX ESY 007, 34
TSX ESY 007 Configuration Screen, 77
TSX ESY 007 Debug Screen, 91
TSX ESY 007 installation, 28

U

Unforcing, 97

V

View I/O, 95
View TSX ESY 007, 95