



Industrial PC

PC Control for all applications



46 Panel PCs



84 Control cabinet Industrial PCs



140 Control Panels

Industrial PC

The right Industrial PC for every application

32	Product overview	84	Control cabinet Industrial PCs	140	Control Panels
38	System description	86	C5xxx 19-inch slide-in Industrial PC	142	Multi-touch Control Panels
42	TwinCAT 3	86	For 19-inch rack installations with 1 or 4 rack units	144	CP29xx Multi-touch built-in Control Panel with DVI/USB Extended interface
46	Panel PCs	92	C61xx Control cabinet Industrial PC	145	The PC operating terminal for installation in the control cabinet door
48	CP62xx "Economy" built-in Panel PC	98	ATX or slot motherboard on pas- sive backplane in 5 housing sizes	146	CP39xx Multi-touch Control Panel with DVI/USB Extended interface
54	CP64xx Built-in Panel PC	104	ATX or slot motherboard on passive backplane in compact drawer housing	146	The PC operating panel for mounting arm installation
58	CP65xx Built-in Panel PC	110	C63xx Control cabinet Industrial PC	148	Accessories for multi-touch Control Panels and Panel PCs
62	CP71xx Panel PC IP 65	118	Slot motherboard on passive backplane in compact aluminium housing	152	Push-button extensions
66	CP72xx Panel PC IP 65	122	C65xx Control cabinet Industrial PC	156	Single-touch Control Panels
70	CP77xx Panel PC IP 65	130	Built-in PC with 3½-inch mother- board and external cooling fins	162	CP66xx Built-in Control Panel with Ethernet interface
74	C33xx 19-inch Panel PC	138	C66xx Control cabinet Industrial PC		The PC operating terminal for installation in the control cabinet door
80	C36xx Built-in Panel PC		ATX motherboard with 3 PCI and 4 PCIe slots		CP69xx Built-in Control Panel with DVI/USB interface
	Industrial PC with display, ATX motherboard with 3 PCI and 4 PCIe slots		C69xx Control cabinet Industrial PC		The PC operating terminal for installation in the control cabinet door
	Industrial PC with display, 3½-inch motherboard, 1 Mini PCI slot		3½-inch motherboard with 1 Mini PCI slot in compact aluminium housing		CP79xx Control Panel with DVI/USB interface
	Industrial PC with display and keyboard, ATX motherboard with 3 PCI and 4 PCIe slots		Industrial PC accessories		The PC operating terminal for mounting arm installation
	Industrial PC with display, ATX motherboard with 3 PCI and 4 PCIe slots		Adapter to extend/branch out DVI/USB, USB flash drive devices, battery pack, slotbox		Accessories for single-touch Control Panels and Panel PCs
			CP-Link 3		Push-button extensions, key- board shelf, additional keyboards, touch screen pen, RFID reader
			Desktop transfer software		

Product overview

Panel PCs

CP62xx-0020,
-0035CP62xx-0010, -0030,
-0040, -0050

CP64xx



CP65xx



CP6207



CP6219



CP6x11



CP6x02



CP6x33



CP6204

Built-in Panel PCs, front side IP 65

	Display Resolution Format	5.7-inch 640 x 480 4:3	6.5-inch 640 x 480 4:3	12-inch 800 x 600 4:3	15-inch 1024 x 768 4:3	19-inch 1280 x 1024 5:4	24-inch 1920 x 1200 16:10					
CP62xx-0010 – 3½-inch motherb. – up to Core™2 Duo – depth 58–67 mm	without keys			CP6201	50	CP6202	50	CP6203	50			
	function keys			CP6211	50	CP6212	50	CP6213	50			
	numerical			CP6221	50	CP6222	50	CP6223	50			
	alphanumeric			CP6231	50	CP6232	50	CP6233	50			
CP62xx-0020 – 3½-inch motherb. – Atom™ processor – depth 58–67 mm	without keys	CP6207	50	CP6209	50	CP6201	50	CP6202	50	CP6203	50	
	function keys			CP6219	50	CP6211	50	CP6212	50	CP6213	50	
	numerical			CP6229	50	CP6221	50	CP6222	50	CP6223	50	
	alphanumeric					CP6231	50	CP6232	50	CP6233	50	
CP62xx-0030, -0035, -0040, -0050 – 3½-inch motherb. – up to Core™ i3/i5/i7 2 nd gen. – depth 58–67 mm	without keys				CP6201	50	CP6202	50	CP6203	50	CP6204	50
	function keys				CP6211	50	CP6212	50	CP6213	50		
	numerical				CP6221	50	CP6222	50	CP6223	50		
	alphanumeric				CP6231	50	CP6232	50	CP6233	50		
CP64xx – slot CPU – up to Core™2 Duo – depth 111–122 mm – 2 slots free	without keys				CP6401	56	CP6402	56	CP6403	56		
	function keys				CP6411	56	CP6412	56	CP6413	56		
	numerical				CP6421	56	CP6422	56	CP6423	56		
	alphanumeric				CP6431	56	CP6432	56	CP6433	56		
CP65xx – ATX – up to Core™ i3/i5/i7 2 nd gen. – depth 196–207 mm – 7 slots free	without keys				CP6501	60	CP6502	60	CP6503	60		
	function keys				CP6511	60	CP6512	60	CP6513	60		
	numerical				CP6521	60	CP6522	60	CP6523	60		
	alphanumeric				CP6531	60	CP6532	60	CP6533	60		
						CP6542	60					



CP71xx



CP72xx



CP77xx



CP770x-14xx



C3320



C3330



C3340



C3350



C3620



C3640

Panel PCs, all sides IP 65

	Display	6.5-inch	12-inch	15-inch	19-inch	24-inch				
	Resolution	640 x 480	800 x 600	1024 x 768	1280 x 1024	1920 x 1200				
	Format	4:3	4:3	4:3	5:4	16:10				
CP71xx – slot CPU – up to Core™ Duo – depth 216–234 mm – 1 slot free	without keys		CP7101	64	CP7102	64	CP7103	64		
	function keys		CP7111	64	CP7112	64	CP7113	64		
	numerical		CP7121	64	CP7122	64	CP7123	64		
	alphanumeric		CP7131	64	CP7132	64	CP7133	64		
					CP7142	64				
CP72xx – 3½-inch motherb. – up to Core™ i3/i5/i7 2 nd gen. – depth 107–123 mm	without keys		CP7201	68	CP7202	68	CP7203	68	CP7204	68
	function keys		CP7211	68	CP7212	68	CP7213	68		
	numerical		CP7221	68	CP7222	68	CP7223	68		
	alphanumeric		CP7231	68	CP7232	68	CP7233	68		
					CP7242	68				
CP77xx-0020 – CP motherboard – AMD LX800 – depth 28–45 mm	without keys	CP7709	72	CP7701	72	CP7702	72	CP7703	72	
	function keys	CP7719	72	CP7711	72	CP7712	72	CP7713	72	
	numerical	CP7729	72	CP7721	72	CP7722	72	CP7723	72	
	alphanumeric			CP7731	72	CP7732	72	CP7733	72	
CP77xx-0030 – CP motherboard – Atom™ processor – depth 28–45 mm	without keys	CP7709	72	CP7701	72	CP7702	72	CP7703	72	
	function keys	CP7719	72	CP7711	72	CP7712	72	CP7713	72	
	numerical	CP7729	72	CP7721	72	CP7722	72	CP7723	72	
	alphanumeric			CP7731	72	CP7732	72	CP7733	72	
Stainless steel opt.			CP7701-14xx	72	CP7702-14xx	72	CP7703-14xx	72		

Built-in Panel PCs, front side IP 65

	Display	6.5-inch	12-inch	15-inch	19-inch	24-inch
	Resolution	640 x 480	800 x 600	1024 x 768	1280 x 1024	1920 x 1200
	Format	4:3	4:3	4:3	5:4	16:10
C33xx – ATX – up to Core™ i3/i5/i7 2 nd gen. – depth 282 mm – 7 slots free	partial keyboard		C3320	76	C3340	78
	full keyboard		C3330	77	C3350	79
C36xx – ATX – up to Core™ i3/i5/i7 2 nd gen. – depth 200 mm – 7 slots free	without keys		C3620	82	C3640	83

Product overview control cabinet Industrial PCs

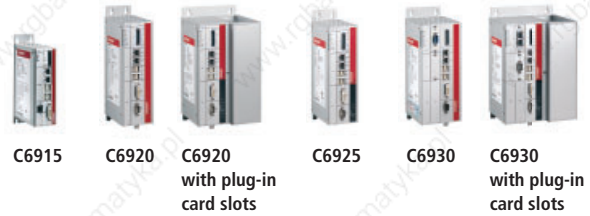

C6515
basic configuration



C6515
with PCIe module slots



C6525
basic configuration



C6525
with PCIe module slots



C6525
with plug-in card slots

Control cabinet Industrial PCs

	Motherboard	3½-inch motherboard			
		Processor	Intel® Atom™	Celeron® ULV, 1.2 GHz	Intel® Core™2 Duo
19-inch slide-in Industrial PC series C5xxx	14 slots, 4 rack units				
	7 slots, 4 rack units 1 Mini PCI slot, 1 rack unit				C5210-0000 90
Control cabinet PC series C61xx, connectors on top	4 slots				
	5 slots 8 slots 7 slots				
Control cabinet PC series C62xx, connectors on front	4 slots				
	6 slots 7 slots				
Compact control cabinet PC series C63xx	3 slots				
	3 slots, fanless 3 slots 3 slots, fanless 5 slots				
Control cabinet PC series C65xx	1 Mini PCI slot			C6515-0010 112	C6515-0020/30 112
	1 Mini PCI, RAID			C6525-0010 114	C6525-0020/30 114
Control cabinet PC series C66xx	7 slots 7 slots, 2 removable frames				
Control cabinet PC series C69xx, connectors on front	1 Mini PCI slot			C6920-0010 125	C6920-0020/30 125
	1 Mini PCI, fanless 1 Mini PCI, RAID	C6915-0000 124	C6925-0010 127	C6930-0010 128	C6930-0020/30 128



	Processor	Intel® IXP420, 266 MHz		Intel® Atom™, 1.1 GHz	
		ARM, 400 MHz	Cortex™-A8, 1 GHz	Pentium® MMX, 500 MHz	Intel® Atom™, 1.6 GHz
Embedded PCs	CX8000 196	CX9000 200	CX1010 210	CX5010 216	
		CX9010 202		CX5020 216	
		CX9020 206			



	Intel® Celeron®, 1.6 GHz Intel® Core™ i3/i5/i7 2 nd gen.	Slot motherboard Intel® Core™ Duo Intel® Core™2 Duo	ATX motherboard Intel® Core™ Duo Intel® Core™2 Duo	Intel® Celeron®, 1.9 GHz Intel® Core™2 Duo	Intel® Celeron®, 1.6 GHz Intel® Core™ i3/i5/i7 2 nd gen.
		C5101-0030 88			
			C5102-0030 89	C5102-0040 89	C5102-0050 89
	C5210-0010 90				
		C6110-0030 94			
		C6120-0030 94			
		C6130-0030 95			
			C6140-0030 96	C6140-0040 96	C6140-0050 96
			C6150-0030 97	C6150-0040 97	C6150-0050 97
		C6210-0030 100			
		C6220-0030 101			
			C6240-0030 102	C6240-0040 102	C6240-0050 102
			C6250-0040 103	C6250-0050 103	C6250-0060 103
		C6320-0040 106			
		C6325-0040 107			
		C6330-0040 106			
		C6335-0040 107			
		C6340-0040 108			
		C6350-0040 109			
	C6515-0040 112				
	C6525-0040 114				
			C6640-0010 120	C6640-0020 120	C6640-0030 120
			C6650-0010 121	C6650-0020 121	C6650-0030 121
	C6920-0040 125				
	C6930-0040 128				

Intel® Celeron® M ULV, 1 GHz Intel® Pentium® M, 1.8 GHz	Intel® Celeron®, 1.4 GHz, single-core	Intel® Core™ i7, 1.5 GHz, dual-core	Intel® Core™ i7, 2.1 GHz, quad-core
CX1020	220	CX2020	234
CX1030	222	CX2030	234
		CX2040	234

Product overview Control Panels



Single-touch built-in Control Panels, front side IP 65

	Display	5.7-inch	6.5-inch	12-inch	15-inch	19-inch	24-inch
	Resolution	640 x 480	640 x 480	800 x 600	1024 x 768	1280 x 1024	1920 x 1200
	Format	4:3	4:3	4:3	4:3	5:4	16:10
Ethernet interface (Embedded PC) – Intel® IXP420 CPU, 533 MHz	without keys	CP6607	CP6609	CP6601	CP6602		
	function keys		CP6619	CP6611	CP6612		
	numerical		CP6629	CP6621	CP6622		
	alphanumerical			CP6631	CP6632		
DVI/USB Extended interface, 50 m	without keys	CP6907	CP6909	CP6901	CP6902	CP6903	CP6904
	function keys		CP6919	CP6911	CP6912	CP6913	
	numerical		CP6929	CP6921	CP6922	CP6923	
	alphanumerical			CP6931	CP6932	CP6933	
					CP6942		



Multi-touch built-in Control Panels, front side IP 65

	Display	7-inch	12-inch	15-inch	15.6-inch	18.5-inch	19-inch	24-inch
	Resolution	800 x 480	800 x 600	1024 x 768	1366 x 768	1366 x 768	1280 x 1024	1920 x 1080
	Format	16:9.6	4:3	4:3	16:9	16:9	5:4	16:9
DVI/USB Extended interface, 50 m	multi-finger touch screen	CP2907	CP2912	CP2915	CP2916	CP2918	CP2919	CP2924



CP7909

CP7911

CP7922

CP7933

CP7904

CP770x-14xx

Single-touch Control Panels, all sides IP 65

	Display	6.5-inch	12-inch	15-inch	19-inch	24-inch
	Resolution	640 x 480	800 x 600	1024 x 768	1280 x 1024	1920 x 1200
	Format	4:3	4:3	4:3	5:4	16:10
DVI/USB Extended interface, 50 m	without keys	CP7909 160	CP7901 160	CP7902 160	CP7903 160	CP7904 160
	function keys	CP7919 160	CP7911 160	CP7912 160	CP7913 160	
	numerical	CP7929 160	CP7921 160	CP7922 160	CP7923 160	
	alphanumeric		CP7931 160	CP7932 160 CP7942 160	CP7933 160	

Single-touch Control Panels in stainless steel housing, all sides IP 65

	Display	6.5-inch	12-inch	15-inch	19-inch	24-inch
	Resolution	640 x 480	800 x 600	1024 x 768	1280 x 1024	1920 x 1200
	Format	4:3	4:3	4:3	5:4	16:10
DVI/USB Extended interface, 50 m	without keys		CP7901-14xx 160	CP7902-14xx 160	CP7903-14xx 160	



CP3907

CP3912

CP3915

CP3916

CP3918

CP3919

CP3924

Multi-touch Control Panels, all sides IP 65

	Display	7-inch	12-inch	15-inch	15.6-inch	18.5-inch	19-inch	24-inch
	Resolution	800 x 480	800 x 600	1024 x 768	1366 x 768	1366 x 768	1280 x 1024	1920 x 1080
	Format	16:9.6	4:3	4:3	16:9	16:9	5:4	16:9
DVI/USB Extended interface, 50 m	multi-finger touch screen	CP3907 145	CP3912 145	CP3915 145	CP3916 145	CP3918 145	CP3919 145	CP3924 145

The right Industrial PC for every application

Robust industrial design PCs with highest performance components

Beckhoff Industrial PCs satisfy industry's demands:

- the right Industrial PC for every controller
- highest performance PCs with Intel® Celeron® up to Intel® Core™ i7 processors
- PCs with low power consumption with Intel® Mobile processors
- open standards following the norm ATX
- components carefully tested to ensure appropriateness for industrial applications
- appealing industrial design housings
- easy access to PC components
- Individual housing construction allows optimum adaptation to controller requirements.
- integration of electromechanical buttons, switches, scanners, handwheels and other components in the Control Panel
- designed for machine-oriented use
- long-term availability of components







Requirements for PC-based control technology

Balance between latest PC technology and long-term availability of control components

The personal computer has experienced an unprecedented success story and has become a firmly established part of everyday life, including industrial environments. Together with associated software, PCs in different shapes and forms are at the core of a wide range of diverse automation tasks such as control of machines, processes or logistics systems, networking of system components, data acquisition, or image processing. For classic control tasks, PC-based control technology offers excellent scalability and flexibility and is therefore increasingly used in place of hardware PLCs.

Beckhoff is one of the pioneers of PC-based automation: the first PC control system was delivered as early as 1986. Beckhoff Industrial PCs are characterised by a wealth of technology know-how accumulated over recent years. In combination with the TwinCAT automation software, they offer a high-performance control system for PLC, NC and CNC functionalities.

An important feature of the Beckhoff product philosophy is the use of advanced, high-performance components and proces-

sors for the development and design of Industrial PCs: they integrate the latest developments offered by the technology market and are used successfully worldwide. Fine scaling is provided for through processor incrementing from Intel® Atom™ up to Intel® Core™ i7. Due to the low processor power dissipation, Intel® Atom™ processors enable extremely small, fanless controllers and are to be found in the lower price range.

In addition to long-standing experience, another factor driving the development of our comprehensive IPC product portfolio is customer-orientation. More than ten Industrial PC series with a wide range of basic PC types form the basis of our product range. The optimally tailored control computer can be found for every application from the large choice of devices and options.

The PC housing varies in size between paperback format to 14-slot passive backplane, depending on the device type. In addition to long-term availability of the built-in processors and motherboards, Beckhoff also offers full commissioning of all integrated components, including software and different drives. Customised solutions can also be realised for optimum adaptation to the respective task.

Elegant Control Panels and Panel PCs

The IPC is complemented by an industrial display unit. The Beckhoff Control Panels and Panel PCs are the visual front end for machines or plants. Spatial separation of display/control unit and control computer offers maximum flexibility. Appealing design, robustness and suitability for industrial applications were important criteria in the development of the Control Panel series, which comes with display sizes between 5.7" and 24".

All displays can be fully tailored to customer requirements: options include visual adaptation to the corporate design or application of a customer logo a wide range of special mechanical keys, emergency stop switches, card scanners or RFID readers.

The Control Panel housing is made from high-quality solid aluminium and is suitable for protection class IP 65, as usually required in industrial environments. Thorough development and integration of electronic modules, displays, touch screens and front membranes ensure high availability and reliability during operation. All Beckhoff Control Panels can optionally be operated as:



- stand-alone device (Panel PC with Windows 7 or Embedded Standard and Ethernet panel with Windows CE);
 - DVI/USB Extended Control Panel for direct or indirect operation at the PC (distance up to 50 m)
- or via
- CP-Link 3 (Panel PCs connected to the host PC via Ethernet).

The CP-Link 3 technology is described on page **138**.

Careful selection of components

A great deal of attention and care is put into the development and choice of the IPC components used, their compatibility, their long-term availability, mechanical loading capacity and industrial suitability. In developing electronic modules, Beckhoff fulfils the high requirements for Industrial PC components that are necessary in order to ensure permanent reliable operation.

Beckhoff is the developer and manufacturer of the motherboards in the Industrial PCs. The BIOS for the motherboards even has its own development department. In addition to that, 24 V DC power supplies with integrated UPS, Ethernet adapters and

Ethernet switches, Fieldbus Cards, DVI display interfaces, DVI/USB extensions and USB hubs are produced by Beckhoff's own development and manufacturing facilities. International standards and experience in the application of PC systems under difficult industrial conditions provide the basis for Beckhoff system integration. Only a few LC displays, plug-in cards or hard disks are suited to use in tough industrial environments. Experience and detailed testing are therefore required for checking whether the components meet the stringent requirements in terms of temperature resistance, resistance to vibration, and electromagnetic compatibility. Prior to delivery, all Industrial PCs are subjected to comprehensive quality control procedures in order to verify that they are fit for the purpose. Beckhoff Industrial PCs satisfy the Machine Guidelines and carry the CE mark: all PC components are checked for electromagnetic compatibility (EMC) and comply with the relevant standards.





TwinCAT 3 | eXtended Automation Technology

Beckhoff created a global standard for automation with the launch of PC-based control technology in 1986. On the software side, the TwinCAT (The Windows Control and Automation Technology) automation suite forms the core of the control system. The TwinCAT software system turns almost any PC-based

system into a real-time control with multiple PLC, NC, CNC and/or robotics runtime systems. TwinCAT 3 is the systematic further development of TwinCAT 2, with which the world of automation technology is being redefined.

TwinCAT 3 highlights

- only one software for programming and configuration
- Visual Studio® integration
- more freedom in selecting programming languages
- support for the object-oriented extension of IEC 61131-3
- use of C/C++ as the programming language for real-time applications
- link to Matlab®/Simulink®
- open interfaces for expandability and adaptation to the tools landscape
- flexible runtime environment
- active support of multi-core and 64-bit systems
- migration of TwinCAT 2 projects

For further information on TwinCAT 3 see page **846**
or ► www.beckhoff.com/TwinCAT3

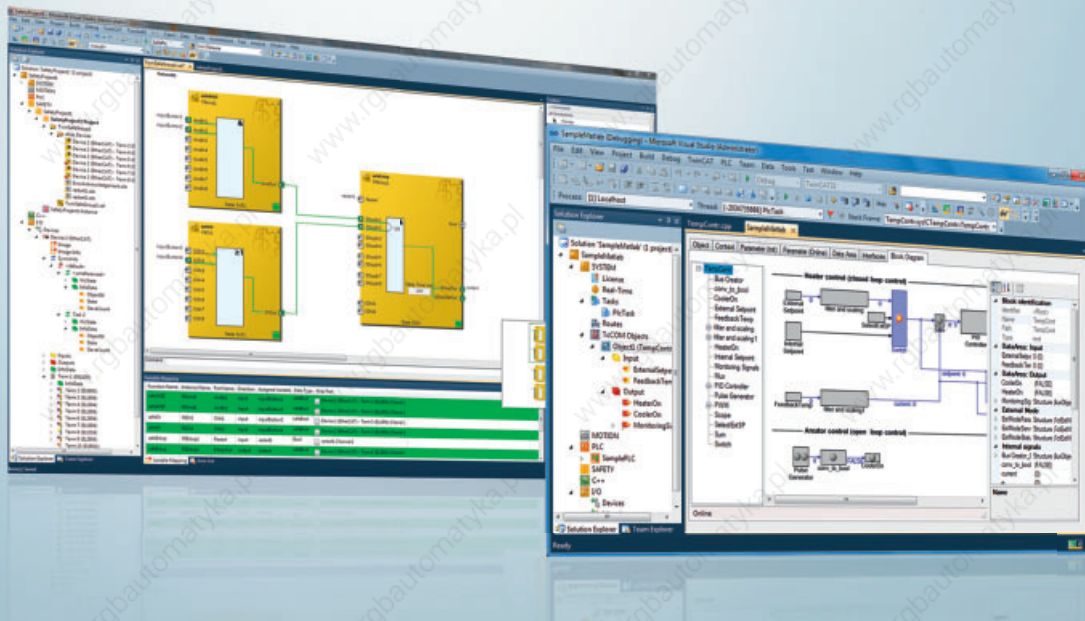

Overview of the TwinCAT 3 performance classes

TwinCAT 3 price structure

TwinCAT offers a modular and component-based price system. Different software modules can be combined. The prices are determined based on the performance of the CPU used (Industrial PC, Panel PC, Embedded PC).

TwinCAT 3 – Platforms

Example of a TwinCAT 3 performance class:

C6920 | Control cabinet Industrial PC with Intel® Core™ i3, 2 cores, processor
 TwinCAT 3 performance class: (TC3: 60), corresponds to the TwinCAT 3 platform P60 Mid performance

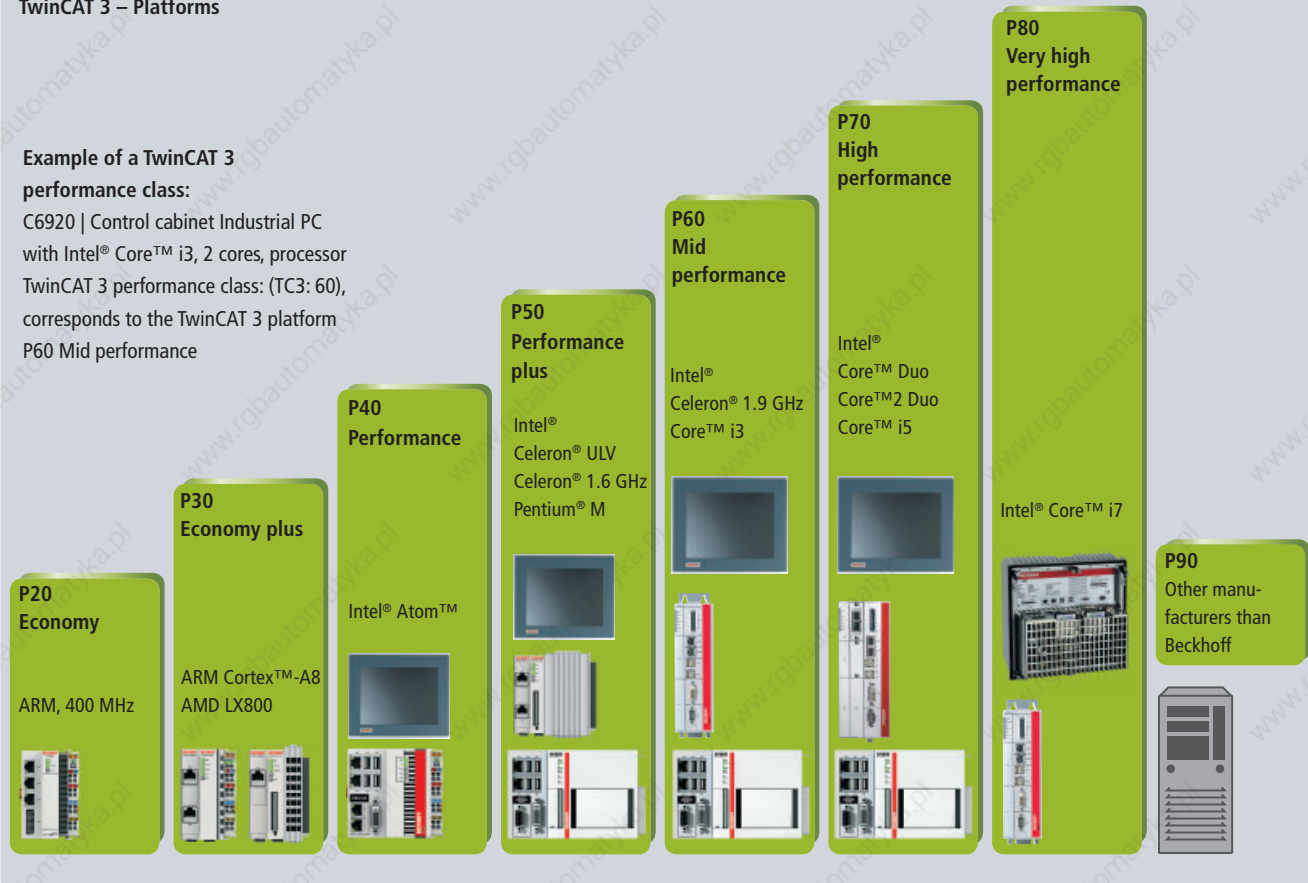

The controllers integrated in the platform categorisation are only example configurations.

The right Industrial PC for every application



Panel PCs

A Beckhoff Panel PC consisting of a Control Panel and an Industrial PC is suitable for control cabinet installation (CP6xxx) or mounting arm installation (CP7xxx). High-performance components make machine-level operation, control and monitoring one of the strengths of the Beckhoff Panel PCs, whose elegant housings are designed for easy accessibility of all components and optimal space utilisation. Different display sizes between 5.7-inch and 24-inch (12-, 15- and 19-inch displays are available in stainless steel design) and various add-on PCs with processors ranging from Intel® Atom™ to Core™ i7 can be combined to form tailored high-performance platforms for machine construction and plant engineering applications.

See page **46**

► www.beckhoff.com/Panel-PC

BECKHOFF New Automation Technology



Control cabinet Industrial PCs

Beckhoff Industrial PCs for control cabinet installation can be scaled in size (paperback format up to 14-slot passive backplane) and performance class (Intel® Atom™ to Core™ i7), depending on the application. The Industrial PC technology represents a balance between the latest PC technology and long-term component availability. In addition, the different product lines are characterised by adaptation to the special circumstances in industrial applications.

See page **84**

► www.beckhoff.com/Control-cabinet-PC

We reserve the right to make technical changes.



Control Panels

The Beckhoff Control Panels used as human-machine interfaces in conjunction with the high-performance Industrial PCs round off a system through their elegant design and the latest PC technology. The display sizes between 5.7-inch and 24-inch meet almost any industrial application requirements and are suitable for mounting arm installation (CP39xx and CP79xx) or direct installation (CP29xx, CP66xx and CP69xx). A wide range of different push-button extensions in conjunction with custom housing designs enable the Control Panel as the visual front end of a system or machine to be tailored to match the corporate identity.

See page **140**

► www.beckhoff.com/ControlPanel



Accessories

Beckhoff accessories complement the Industrial PCs while complying with industrial standards: CP-Link 3 desktop transfer software, DVI splitters, USB extensions and hubs, USB CFast slot, USB Compact Flash slot, USB Ethernet controllers, WLAN controllers and antennas, battery packs, USB sticks, PCIe modules, add-in cards.

Industrial PC accessories see page **130**

Extensions for Control Panels and Panel PCs: push-button extensions (with electromechanical buttons, switches and indicator lamps), auxiliary keyboards, keyboard shelves, touch screen pens, RFID readers

Control Panel accessories see page **162**

Panel PCs



CP77xx | Panel PC with mounting arm

Fanless, compact central processing unit

- display sizes: 6.5-, 12-, 15- or 19-inch
- CP motherboard
- protection class IP 65
- operating temperature range: 0...55 °C

See page **70**

► www.beckhoff.com/Panel-PC



CP64xx |

Built-in Panel PC

- display sizes: 12-, 15- or 19-inch
- slot motherboard

See page **54**

CP65xx |

Built-in Panel PC

- display sizes: 12-, 15- or 19-inch
- ATX motherboard

See page **58**

CP71xx |

Panel PC with mounting arm

- display sizes: 12-, 15- or 19-inch
- slot motherboard

See page **62**

C33xx |

19-inch built-in Panel PC

- display sizes: 12- or 15-inch
- ATX motherboard

See page **74**

C36xx |

Built-in Panel PC

- display sizes: 12- or 15-inch
- ATX motherboard

See page **80****CP72xx | Panel PC with mounting arm**

"Economy" Industrial PC

- display sizes: 12-, 15-, 19- or 24-inch
- 3½-inch motherboard
- protection class IP 65
- operating temperature range: 0...45 °C

See page **66****CP62xx | Built-in Panel PC**

The slimline built-in Industrial PC

- display sizes: 5.7-, 6.5-, 12-, 15-, 19- or 24-inch
- 3½-inch motherboard
- protection class front side IP 65, rear side IP 20
- operating temperature range: 0...55 °C

See page **48**

CP62xx | "Economy" built-in Panel PC

The CP62xx built-in Panel PC-series is designed for installation in the front of a control cabinet. The CP62xx series combines the Beckhoff Control Panel design with state-of-the-art Industrial PC technology. The right display size and keyboard are available for every application. With their highly integrated 3½-inch motherboards, the CP62xx built-in Industrial PCs represent a high-performance platform for machine construction and plant

engineering applications that can be used in conjunction with TwinCAT automation software under Windows Embedded Standard, Windows XP or Windows 7.

The CP62xx Panel PCs are available with a choice of Intel® processors. They are equipped with CFast and have no rotating parts. Alternatively a hard disk is available. Units containing the more powerful Intel® Core™ i3/i5/i7 processors of the 2nd genera-

tion feature a fan cartridge with speed-controlled fans supported by dual ball bearings. In front of the fan cartridge a 2 cm space is required for ventilation. In each configuration the Panel PCs of this series are approved for ambient temperatures between 0 and 55 °C.

The CP62xx are supplied with a 24 V power supply unit, optionally also with an integrated uninterruptible power supply (UPS). A battery pack can be connected



Front laminates



Without keys

Function keys

Numeric keyboard

Alphanumeric keyboard

With PLC keys on the sides

externally and installed on a DIN rail close to the PC. For the CP62xx with Intel® Atom™ a 1-second UPS solution without battery pack is available. Capacitors integrated on the motherboard maintain PC operation for a few seconds, so that key variables can be saved.

Different basic configurations are available for the individual versions, ranging from a 2 GB CFast card with Windows CE to a 2½-inch hard disk. Two CFast cards or a hard

disk and a CFast plus the lithium battery of the system clock are accessible from the rear in the plug connector panel.

Due to its two independent Ethernet interfaces the CP62xx is ideally suited as a compact central processing unit for an EtherCAT control system. A free Mini PCI slot enables different fieldbus cards or a third, independent Ethernet interface to be used. NOVRAM for fail-safe data storage

can also be plugged into the Mini PCI slot. The CP62xx-0030, -0035, -0040 and -0050 versions can optionally be extended with module or plug-in card slots (see page 52).

DVI connection

Hard disk or SSD

CF or CFast flash card

TFT display

1 Mini PCI slot for fieldbus cards

3½-inch motherboard

Power supply 24 V DC, optionally with UPS

On-board dual Ethernet adapter

4 USB 2.0 ports

1 serial interface RS232

Lithium battery accessible from the rear side

optionally 2 PCI or PCIe plug-in card slots
optionally 2 PCIe module slots

► www.beckhoff.com/CP62xx



CP62xx | "Economy" built-in Panel PC

The slimline built-in Industrial PC with 3½-inch motherboard

Ordering information	without touch screen	with single-touch screen	with touch pad
Display only			
5.7-inch display 640 x 480	CP6207-0000-0020*	CP6207-0001-0020*	
6.5-inch display 640 x 480	CP6209-0000-0020*	CP6209-0001-0020*	
12-inch display 800 x 600	CP6201-0000-00xx	CP6201-0001-00xx	
15-inch display 1024 x 768	CP6202-0000-00xx	CP6202-0001-00xx	
19-inch display 1280 x 1024	CP6203-0000-00xx	CP6203-0001-00xx	
24-inch display 1920 x 1200	CP6204-0000-0030/-40/-50	CP6204-0000-0030/-40/-50	
Display only, USB A socket in the front			
12-inch display 800 x 600	CP6201-0020-00xx	CP6201-0021-00xx	
15-inch display 1024 x 768	CP6202-0020-00xx	CP6202-0021-00xx	
19-inch display 1280 x 1024	CP6203-0020-00xx	CP6203-0021-00xx	
24-inch display 1920 x 1200	CP6204-0000-0030/-40/-50	CP6204-0000-0030/-40/-50	
With function keys			
6.5-inch display 640 x 480	CP6219-0000-0020*	CP6919-0001-0020*	
12-inch display 800 x 600	CP6211-0000-00xx	CP6211-0001-00xx	
15-inch display 1024 x 768	CP6212-0000-00xx	CP6212-0001-00xx	
19-inch display 1280 x 1024	CP6213-0000-00xx	CP6213-0001-00xx	
Numeric keyboard			
6.5-inch display 640 x 480	CP6229-0000-0020*	CP6929-0001-0020*	
12-inch display 800 x 600	CP6221-0000-00xx	CP6221-0001-00xx	CP6221-0002-00xx
15-inch display 1024 x 768	CP6222-0000-00xx	CP6222-0001-00xx	CP6222-0002-00xx
19-inch display 1280 x 1024	CP6223-0000-00xx	CP6223-0001-00xx	CP6223-0002-00xx
Alphanumeric keyboard			
12-inch display 800 x 600	CP6231-0000-00xx	CP6231-0001-00xx	CP6231-0002-00xx
15-inch display 1024 x 768	CP6232-0000-00xx	CP6232-0001-00xx	CP6232-0002-00xx
19-inch display 1280 x 1024	CP6233-0000-00xx	CP6233-0001-00xx	CP6233-0002-00xx
Alphanumeric keyboard with PLC keys on the sides			
15-inch display 1024 x 768	CP6242-0000-00xx	CP6242-0001-00xx	

*without hard disk slot, max. 1 CF slot

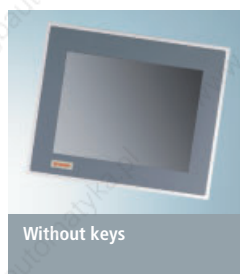

Without keys



Function keys



Numeric keyboard



Alphanumeric keyboard

Alphanumeric keyboard
with PLC keys on the sides

CP62xx	CP62xx-xxxx-0010, -0020, -0030, -0035, -0040, -0050
Housing	aluminium front with steel sheet rear cover drives easily accessible all connectors at the bottom of the rear side 1 slot for one 2½-inch hard disk or SSD and 1 slot for one flash card accessible from the rear side fan cartridge at the rear side, accessible from outside for CP62xx-0010, -0030, -0040, -0050 fanless for CP62xx-0020, -0035 lithium battery of the system clock accessible from the rear side pull-out clamping levers for fast installation without loose parts protection class front side IP 65, rear side IP 20 operating temperature 0...55 °C

Features	CP62xx-xxxx-0010	CP62xx-xxxx-0020	CP62xx-xxxx-0030	CP62xx-xxxx-0035	CP62xx-xxxx-0040	CP62xx-xxxx-0050
Display	12-, 15- or 19-inch TFT display	5.7-, 6.5-, 12-, 15- or 19-inch TFT display	12-, 15-, 19- or 24-inch TFT display	12-, 15- or 19-inch TFT display	12-, 15-, 19- or 24-inch TFT display	12-, 15-, 19- or 24-inch TFT display
Processor	Intel® Core™ Duo or Core™2 Duo	Intel® Atom™	Intel® Core™2 Duo	Intel® Celeron® ULV	Intel® Celeron® up to Core™2 Duo	up to Core™ i3/i5/i7 2 nd generation
Motherboard	3½-inch	3½-inch	3½-inch	3½-inch	3½-inch	3½-inch
Slots	1 Mini PCI slot	1 Mini PCI slot	1 Mini PCI, optionally 2 PCIe modules or 2 plug-in card slots	1 Mini PCI, optionally 2 PCIe modules or 2 plug-in card slots	1 Mini PCI, optionally 2 PCIe modules or 2 plug-in card slots	1 Mini PCI, optionally 2 PCIe modules or 2 plug-in card slots
Free slots	1 Mini PCI slot	1 Mini PCI slot	1 Mini PCI and optionally 2 PCIe modules or 2 PCI/PCIe plug-in card slots	1 Mini PCI and optionally 2 PCIe modules or 2 PCI/PCIe plug-in card slots	1 Mini PCI and optionally 2 PCIe modules or 2 PCI/PCIe plug-in card slots	1 Mini PCI and optionally 2 PCIe modules or 2 PCI/PCIe plug-in card slots
Max. card length	Mini PCI	Mini PCI	Mini PCI, optionally 2 PCIe modules or 2 x 190 mm plug-in cards	Mini PCI, optionally 2 PCIe modules or 2 x 190 mm plug-in cards	Mini PCI, optionally 2 PCIe modules or 2 x 190 mm plug-in cards	Mini PCI, optionally 2 PCIe modules or 2 x 190 mm plug-in cards
Memory	1...3 GB DDR2RAM	1...2 GB DDR2RAM	1...8 GB DDR3 RAM	1...8 GB DDR3 RAM	1...8 GB DDR3 RAM	2...16 GB DDR3 RAM
Graphic adapter	on-board	on-board	on-board	on-board	on-board	integrated in the processor
Ethernet	2 on-board	2 on-board	2 on-board	2 on-board	2 on-board	2 on-board
Hard disks/flash	2½-inch HDD or SSD and/or CF card or 2 CF cards	2½-inch HDD or SSD and/or CF card or 2 CF cards	2½-inch HDD or SSD and/or CF card or 2 CF cards	2½-inch HDD or SSD and/or 1 x CFast or 2 x CFast	2½-inch HDD or SSD and/or 1 x CFast or 2 x CFast	2½-inch HDD or SSD and/or 1 x CFast or 2 x CFast
RAID 1	–	–	–	2 x CFast	2 x CFast	2 x CFast
Power supply	24 V DC	24 V DC	24 V DC	24 V DC	24 V DC	24 V DC
Recommendation	not recommended for new projects	available	available	recommended for new projects	recommended for new projects	recommended for new projects
Further information	for further options, technical drawings, documentations, etc. see www.beckhoff.com/CP62xx					



CP62xx-xxxx-0030/-0035/-0040/-0050 with PCIe module slots C9900-B500; CP62xx-xxxx-0035 is fanless.



CP62xx-xxxx-0030, -0035, -0040 and -0050 | Extension for PCIe modules

The Panel PCs CP62xx-xxxx-0030, -0035, -0040 and -0050 can be expanded by two additional PCIe module slots. The rear cover is constructed 30 mm deeper for PCIe modules (see above). The module slots can accept Beckhoff PCIe modules, for example,

the FC9062 dual gigabit Ethernet module, or they can serve to lead out motherboard interfaces, such as COM ports, USB or sound.



PCIe module FC9062, dual gigabit Ethernet

Ordering information	Options for CP62xx-xxxx-0030, -0035, -0040, -0050
C9900-B500	2 PCIe module slots integrated inside CP62xx, to plug-in Beckhoff PCIe modules or to lead out interfaces of the motherboard ex factory. The depth of the back cover is increased by 30 mm (1.2").

Ordering information	Options for CP62xx with 2 module slots C9900-B500
FC9062	gigabit Ethernet PCIe module for PCs with Beckhoff PCIe module slots, 2-channel, PCI Express x1 bus
C9900-E232	sound line input and sound line output of the motherboard led out at the connection section of a CP62xx
C9900-E233	1 serial port RS232 of the motherboard led out at the connection section of a CP62xx
C9900-E234	2 USB ports of the motherboard led out at the connection section of a CP62xx



CP62xx-xxxx-0030/-0035/-0040/-0050 with plug-in card slots C9900-B504, -B508 or -B512; CP62xx-xxxx-0035 is fanless.

CP62xx-xxxx-0030, -0035, -0040 and -0050 | Extension for PCI and PCIe plug-in cards

The Panel PCs CP62xx-xxxx-0030, -0035, -0040 and -0050 can be expanded by two slots for standard PC plug-in cards. They can accept conventional PC plug-in cards up to 190 mm in length. The 66 mm deeper hood at the rear (see above) covers

a backplane that provides a choice of two PCI slots, two PCI Express slots or one PCI and one PCI Express slot. Card holders ensure the secure fixation of large cards.

Ordering information	Options for CP62xx-xxxx-0030, -0035, -0040, -0050
C9900-B504	2 PCIe plug-in card slots on the passive backplane integrated inside CP62xx, to plug-in PCIe x1 cards up to 190 mm length. The depth of the back cover is increased by 66 mm (2.6").
C9900-B508	2 PCI plug-in card slots on the passive backplane integrated inside CP62xx, to plug-in PCI cards up to 190 mm length. The depth of the back cover is increased by 66 mm (2.6").
C9900-B512	1 PCI and 1 PCIe plug-in card slot on a passive backplane integrated inside CP62xx, to plug-in one PCI and one PCIe x1 card up to 190 mm (6.3") length. The depth of the back cover is increased by 66 mm (2.6").

CP64xx | Built-in Panel PC

The Panel PC series CP64xx is designed for installation in the front of a control cabinet. A built-in Control Panel CP68xx with DVI and USB interface is the front of the Panel PC. The correct display size and keyboard are thus available for every application. The CP64xx

built-in Industrial PCs represent a powerful platform for machine construction and plant engineering applications, for example with the TwinCAT automation software under Windows Embedded Standard, Windows XP or Windows 7.

The 4-slot add-on PC CP64xx complements the built-in Control Panels by a full Industrial PC. The Panel PCs can be equipped with a 12-, 15- or 19-inch TFT display, as a monitor without keys or with different types of keyboards. A touch screen or touch pad



Front laminates



Without keys

Function keys

Numeric keyboard

Alphanumeric keyboard

With PLC keys on the sides

is optionally available. A large number of expansion options with electromechanical keys is also available. A compact PC housing is installed on the back wall of the Control Panel, which is equipped with Intel® Core™ Duo or Core™2 Duo on an all-in-one slot

motherboard with passive backplane. Two free slots are available. A CD/DVD-ROM or multi DVD drive can be installed. A 100 to 240 V AC full range or a 24 V DC power supply unit is installed in the PC. The Control Panel is connected to the PC

via DVI and USB. The PC supplies power to the Control Panel. The cables are installed in the PC housing.

Power supply 100–240 V full range or 24 V DC, optionally with 24 V DC UPS

Fan with speed monitoring and double ball bearing, easily exchangeable

Slot motherboard

Hard disk or SSD

DVD drive slot

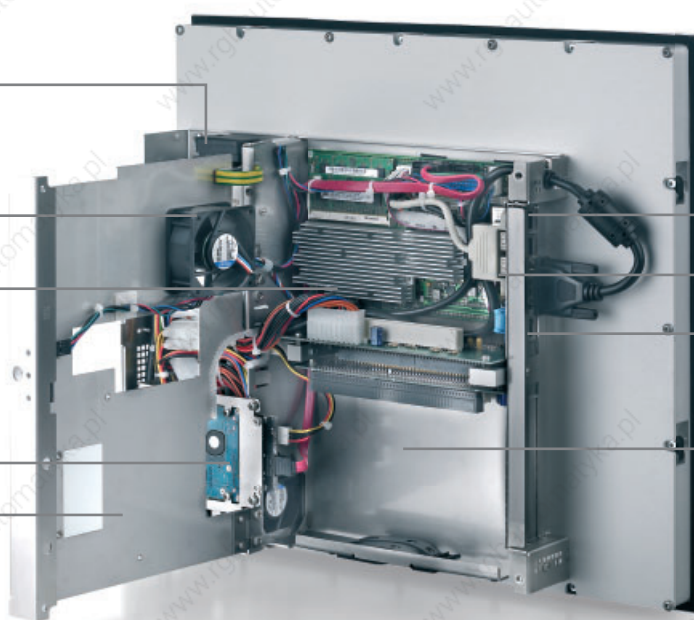

TFT display

On-board dual Ethernet adapter

3 USB 2.0 ports

1 serial interface RS232

2 PCI slots free

► www.beckhoff.com/CP64xx



CP64xx | Built-in Panel PC

The flat built-in Industrial PC with slot motherboard

Ordering information	without touch screen	with single-touch screen	with touch pad
Display only			
12-inch display 800 x 600	CP6401-0000-0040	CP6401-0001-0040	
15-inch display 1024 x 768	CP6402-0000-0040	CP6402-0001-0040	
19-inch display 1280 x 1024	CP6403-0000-0040	CP6403-0001-0040	
Display only, USB A socket in the front			
12-inch display 800 x 600	CP6401-0020-0040	CP6401-0021-0040	
15-inch display 1024 x 768	CP6402-0020-0040	CP6402-0021-0040	
19-inch display 1280 x 1024	CP6403-0020-0040	CP6403-0021-0040	
With function keys			
12-inch display 800 x 600	CP6411-0000-0040	CP6411-0001-0040	
15-inch display 1024 x 768	CP6412-0000-0040	CP6412-0001-0040	
19-inch display 1280 x 1024	CP6413-0000-0040	CP6413-0001-0040	
Numeric keyboard			
12-inch display 800 x 600	CP6421-0000-0040	CP6421-0001-0040	CP6421-0002-0040
15-inch display 1024 x 768	CP6422-0000-0040	CP6422-0001-0040	CP6422-0002-0040
19-inch display 1280 x 1024	CP6423-0000-0040	CP6423-0001-0040	CP6423-0002-0040
Alphanumeric keyboard			
12-inch display 800 x 600	CP6431-0000-0040	CP6431-0001-0040	CP6431-0002-0040
15-inch display 1024 x 768	CP6432-0000-0040	CP6432-0001-0040	CP6432-0002-0040
19-inch display 1280 x 1024	CP6433-0000-0040	CP6433-0001-0040	CP6433-0002-0040
Alphanumeric keyboard with PLC keys on the sides			
15-inch display 1024 x 768	CP6442-0000-0040	CP6442-0001-0040	



Without keys

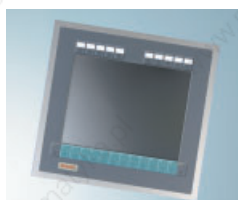

Function keys



Numeric keyboard



Alphanumeric keyboard

Alphanumeric keyboard
with PLC keys on the sides

CP64xx	CP64xx-xxxx-0040
Housing	4-slot housing
	2 slots for plug-in cards with a length of up to 190 mm
	drives and plug-in cards easily accessible
	status LEDs and protected reset key
	card holders, actuated without tools
	pull-out clamping levers for fast installation without loose parts
	protection class front side IP 65, rear side IP 20
	operating temperature 0...55 °C

Features	CP64xx-xxxx-0040
Display	12-, 15- or 19-inch TFT display
Processor	Intel® Core™ Duo or Core™2 Duo
Motherboard	passive backplane
Slots	4
Free slots	2 PCI
Max. card length	2 x 190 mm
Memory	1...3 GB DDR2RAM
Graphic adapter	on-board
Ethernet	2 on-board
Hard disks/flash	1 x 2½-inch HDD or SSD
Possible disk drives	CD/DVD-ROM or multi-DVD
Power supply	100...240 V AC or 24 V DC
Recommendation	not recommended for new projects
Further information	for further options, technical drawings, documentations, etc. see www.beckhoff.com/CP64xx

CP65xx | Built-in Panel PC

The Panel PC series CP65xx is designed for installation in the front of a control cabinet. A built-in Control Panel with DVI and USB interface is the front of the Panel PC. The correct display size and keyboard are thus available for every application.

The CP65xx built-in Industrial PCs represent a powerful platform for machine construction and plant engineering applications, for example with the TwinCAT automation software under Windows Embedded Standard, Windows XP or Windows 7.

The 7-slot ATX add-on PC CP65xx complements all types of built-in Control Panels CP68xx by a full Industrial PC. The Panel PCs can be equipped with 12-, 15- or 19-inch TFT display, as a monitor without keys or with different types of keyboards. A touch screen



Front laminates



Without keys

Function keys

Numeric keyboard

Alphanumeric keyboard

With PLC keys on the sides

or touch pad is optionally available. A large number of push-button extensions are also available.

An ATX PC housing is mounted on the backplane of the Control Panel, which can be equipped with Intel® Celeron®, Core™2

Duo or Core™ i3/i5/i7 processors of the 2nd generation on an ATX motherboard. Three PCI and three PCI Express slots are available. A CD/DVD-ROM or multi DVD drive can be installed. A 100 to 240 AC full range power supply or a 24 V DC power supply is

used in the PC. The Control Panel is connected to the PC via DVI and USB. The PC deals with the power supply for the Control Panel. The cables are installed in the PC housing.

TFT display

4 USB 2.0 ports

6 slots free

ATX motherboard

Fan with speed monitoring and double ball bearing, easily exchangeable

Hard disk or SSD

On-board Ethernet adapter

1 serial interface RS232

Power supply 100–240 V full range or 24 V DC, optionally with 24 V DC UPS

DVD drive slot

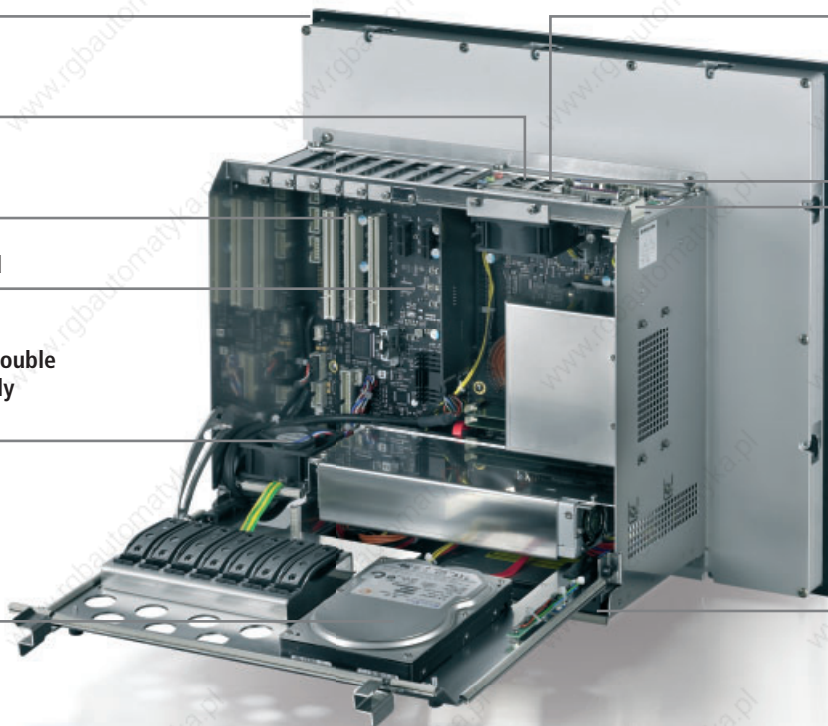

► www.beckhoff.com/CP65xx



CP65xx | Built-in Panel PC

The universal built-in Industrial PC with ATX motherboard

Ordering information	without touch screen	with single-touch screen	with touch pad
Display only			
12-inch display 800 x 600	CP6501-0000-xxxx	CP6501-0001-xxxx	
15-inch display 1024 x 768	CP6502-0000-xxxx	CP6502-0001-xxxx	
19-inch display 1280 x 1024	CP6503-0000-xxxx	CP6503-0001-xxxx	
Display only, USB A socket in the front			
12-inch display 800 x 600	CP6501-0020-xxxx	CP6501-0021-xxxx	
15-inch display 1024 x 768	CP6502-0020-xxxx	CP6502-0021-xxxx	
19-inch display 1280 x 1024	CP6503-0020-xxxx	CP6503-0021-xxxx	
With function keys			
12-inch display 800 x 600	CP6511-0000-xxxx	CP6511-0001-xxxx	
15-inch display 1024 x 768	CP6512-0000-xxxx	CP6512-0001-xxxx	
19-inch display 1280 x 1024	CP6513-0000-xxxx	CP6513-0001-xxxx	
Numeric keyboard			
12-inch display 800 x 600	CP6521-0000-xxxx	CP6521-0001-xxxx	CP6521-0002-xxxx
15-inch display 1024 x 768	CP6522-0000-xxxx	CP6522-0001-xxxx	CP6522-0002-xxxx
19-inch display 1280 x 1024	CP6523-0000-xxxx	CP6523-0001-xxxx	CP6523-0002-xxxx
Alphanumeric keyboard			
12-inch display 800 x 600	CP6531-0000-xxxx	CP6531-0001-xxxx	CP6531-0002-xxxx
15-inch display 1024 x 768	CP6532-0000-xxxx	CP6532-0001-xxxx	CP6532-0002-xxxx
19-inch display 1280 x 1024	CP6533-0000-xxxx	CP6533-0001-xxxx	CP6533-0002-xxxx
Alphanumeric keyboard with PLC keys on the sides			
15-inch display 1024 x 768	CP6542-0000-xxxx	CP6542-0001-xxxx	



Without keys

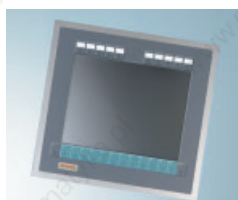

Function keys



Numeric keyboard



Alphanumeric keyboard

Alphanumeric keyboard
with PLC keys on the sides

CP65xx	CP65xx-xxxx-0050, -0060, -0070
Housing	7-slot ATX housing all slots for up to 190 mm long plug-in cards drives and plug-in cards easily accessible all connectors on the top detailed PC configuration information on the housing card holders, actuated without tools status LEDs and protected reset key pull-out clamping levers for fast installation without loose parts protection class front side IP 65, rear side IP 20 operating temperature 0...55 °C

Features	CP65xx-xxxx-0050	CP65xx-xxxx-0060	CP65xx-xxxx-0070
Display	12-, 15- or 19-inch TFT display	12-, 15- or 19-inch TFT display	12-, 15- or 19-inch TFT display
Processor	Intel® Core™ Duo or Core™2 Duo	Intel® Celeron® up to Core™2 Duo	up to Core™ i3/i5/i7 2 nd generation
Motherboard	ATX	ATX	ATX
Slots	7	7	7
Free slots	3 PCI and 3 PCIe x1	3 PCI and 3 PCIe x1	3 PCI, 2 PCIe x1, 1 PCIe x4 and 1 PCIe x16
Max. card length	6 x 190 mm	6 x 190 mm	7 x 190 mm
Memory	1...3 GB DDR2RAM	1...8 GB DDR3 RAM	2...16 GB DDR3 RAM
Graphic adapter	on-board	on-board	integrated in the processor
Ethernet	on-board	on-board	2 on-board
Hard disks/flash	1 x 3½-inch HDD or 2½-inch SSD	1 x 3½-inch HDD or 2½-inch SSD	1 x 3½-inch HDD or 2½-inch SSD
Possible disk drives	CD/DVD-ROM or multi-DVD	CD/DVD-ROM or multi-DVD	CD/DVD-ROM or multi-DVD
Power supply	100...240 V AC or 24 V DC	100...240 V AC or 24 V DC	100...240 V AC or 24 V DC
Recommendation	not recommended for new projects	available	recommended for new projects
Further information	for further options, technical drawings, documentations, etc. see www.beckhoff.com/CP65xx		

CP71xx | Waterproof Panel PC with mounting arm

The CP71xx Panel PC series is designed for installation on a mounting arm. Control Panels form the front of the IP 65 Panel PC. The right display size and keyboard are thus available for every application. The CP71xx Industrial PCs represent a high-performance platform for machine construction and plant engineering applications that can be used

in conjunction with TwinCAT automation software under Windows Embedded Standard, Windows XP or Windows 7.

The CP71xx 4-slot add-on PC complements the Control Panel series with a fully-fledged Industrial PC. Behind the Control Panel there is an aluminium housing with protection class IP 65 that can accommo-

date all components required for a high-performance PC with Intel® Core™ Duo or Core™2 Duo.

A CD/DVD-ROM or multi DVD drive can be installed behind a door at the side. The cooling is achieved by means of cooling fins on the outer wall. A fan within the enclosed housing ensures uniform distri-



Front laminates



Without keys

Function keys

Numeric keyboard

Alphanumeric keyboard

With PLC keys on the sides

bution of the heat. The PC can be operated at up to 45 °C ambient temperature. The housing is designed for mounting arm installation with the Rolec mounting arm system. The mounting arm can be fitted from above or below. The connecting cables are laid through the mounting arm. The housing

can be opened without having to remove the device from the mounting arm, offering fast access to all integrated components.

The CP71xx add-on PC is designed for mounting behind a Beckhoff Control Panel. The IP 65 Panel PCs can be equipped with 12-, 15- or 19-inch LC displays, as a moni-

tor without keyboard or different types of keyboards. Optionally a touch screen or touch pad is available. In addition, a large number of push-button extensions are available.

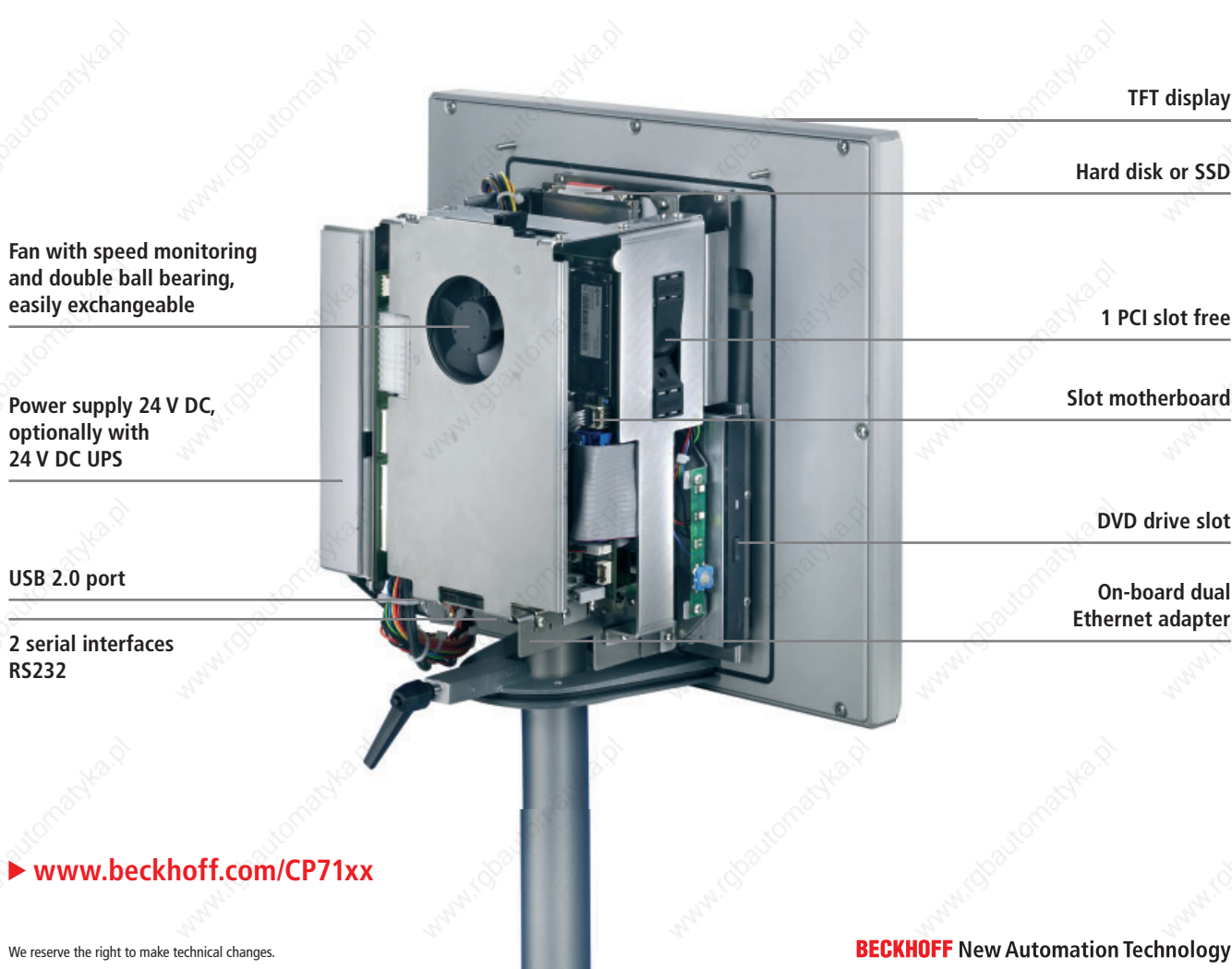

Fan with speed monitoring and double ball bearing, easily exchangeable

Power supply 24 V DC, optionally with 24 V DC UPS

USB 2.0 port

2 serial interfaces RS232

TFT display

Hard disk or SSD

1 PCI slot free

Slot motherboard

DVD drive slot

On-board dual Ethernet adapter

► www.beckhoff.com/CP71xx



CP71xx | Panel PC

The Industrial PC with mounting arm and slot motherboard

Ordering information	without touch screen	with single-touch screen	with touch pad
Display only			
12-inch display 800 x 600	CP7101-0000-0050	CP7101-0001-0050	
15-inch display 1024 x 768	CP7102-0000-0050	CP7102-0001-0050	
19-inch display 1280 x 1024	CP7103-0000-0050	CP7103-0001-0050	
Display only, USB A socket in the front			
12-inch display 800 x 600	CP7101-0020-0050	CP7101-0021-0050	
15-inch display 1024 x 768	CP7102-0020-0050	CP7102-0021-0050	
19-inch display 1280 x 1024	CP7103-0020-0050	CP7103-0021-0050	
With function keys			
12-inch display 800 x 600	CP7111-0000-0050	CP7111-0001-0050	
15-inch display 1024 x 768	CP7112-0000-0050	CP7112-0001-0050	
19-inch display 1280 x 1024	CP7113-0000-0050	CP7113-0001-0050	
Numeric keyboard			
12-inch display 800 x 600	CP7121-0000-0050	CP7121-0001-0050	CP7121-0002-0050
15-inch display 1024 x 768	CP7122-0000-0050	CP7122-0001-0050	CP7122-0002-0050
19-inch display 1280 x 1024	CP7123-0000-0050	CP7123-0001-0050	CP7123-0002-0050
Alphanumeric keyboard			
12-inch display 800 x 600	CP7131-0000-0050	CP7131-0001-0050	CP7131-0002-0050
15-inch display 1024 x 768	CP7132-0000-0050	CP7132-0001-0050	CP7132-0002-0050
19-inch display 1280 x 1024	CP7133-0000-0050	CP7133-0001-0050	CP7133-0002-0050
Alphanumeric keyboard with PLC keys on the sides			
15-inch display 1024 x 768	CP7142-0000-0050	CP7142-0001-0050	



Without keys



Function keys



Numeric keyboard



Alphanumeric keyboard

Alphanumeric keyboard
with PLC keys on the sides

CP71xx	CP71xx-xxxx-0050
Housing	4-slot housing
	1 slot for plug-in cards with a length of up to 190 mm
	drives and plug-in cards easily accessible
	mounting arm connector for Roolec part 146.025.016 from top or bottom
	side door to access the CD/DVD drive
	status LEDs and reset key behind the side door
	card holders, actuated without tools
	passive cooling through heat sink structure at the outer housing, internal fan for equal heat distribution to all the walls of the housing
	50 cm free space required around the PC for air circulation
	fan quickly exchangeable from outside
	protection class IP 65
	operating temperature 0...45 °C

Features	CP71xx-xxxx-0050
Display	12-, 15- or 19-inch TFT display
Processor	Intel® Core™ Duo or Core™2 Duo
Motherboard	passive backplane
Slots	4
Free slots	1 PCI
Max. card length	1 x 190 mm
Memory	1...3 GB DDR2RAM
Graphic adapter	on-board
Ethernet	2 on-board
Hard disks/flash	1 x 2½-inch HDD or SSD
Possible disk drives	DVD-ROM or multi-DVD
Power supply	24 V DC
Recommendation	not recommended for new projects
Further information	for further options, technical drawings, documentations, etc. see www.beckhoff.com/CP71xx

CP72xx | "Economy" Panel PC with mounting arm

The CP72xx "Economy" Panel PC series is designed for mounting arm installation. Control Panels form the front of the IP 65 Panel PC. The right display size and keyboard are thus available for every application. The CP72xx Industrial PCs represent a powerful platform for use in machine and plant construction, for example using the TwinCAT automation software under Windows Embedded Standard, Windows XP Professional or Windows 7.

The PC can be equipped with a 12-, 15-, 19- or 24-inch LC display as a monitor without keys or with different types of keyboards. Optionally, a touch screen or touch pad is available. In addition, a large number of push-button extensions are available.

Cooling is achieved via cooling ribs between the Control Panel and the add-on PC. A fan inside the closed housing ensures that the heat is distributed evenly. The PC can be operated at up to 45 °C ambient temperature.

The housing is designed for installation on a mounting arm. There is a choice of attaching the mounting arm from above or below. The Panel PC features an integrated rotatable mounting arm adapter for a 48 mm diameter mounting arm tube. Optionally, a rotatable and tiltable mounting arm adapter can be integrated in the Panel PC. The connecting cables are laid through the mounting arm.

The compact aluminium housing of the CP72xx Panel PCs is equipped with a 3½-inch



Front laminates



Without keys

Function keys

Numeric keyboard

Alphanumeric keyboard

With PLC keys on the sides

Beckhoff Motherboard for Intel® Core™ i3/i5/i7 processors of the 2nd generation.

The Industrial PC connections (up to six) with IP 65 connectors are positioned in the large wiring space and are easily accessible. The wiring area can be opened easily without dismantling the device from the mounting arm, offering fast access to the IP 65 connectors for power supply, Ethernet and optional fieldbus, USB or RS232. Prefabricated cables in various lengths are available for all connections.

Due to its two independent Ethernet interfaces the CP72xx is ideally suited as a compact central processing unit for an EtherCAT control system.

The C72xx series Panel PCs are supplied with a 24 V power supply unit, optionally with integrated uninterruptible power supply (UPS). A battery pack can be connected externally and installed on a DIN rail in the control cabinet.

One or two CF or CFast cards or up to two hard disks or SSDs, as well as the lithium

battery for the system clock, are accessible from the rear side underneath a cover.

Two hard disks, two SSDs or two CFast cards can be mirrored using the on-board SATA RAID 1 controller.

There is a Mini PCI slot in the CP72xx. The Beckhoff Mini PCI Ethernet or fieldbus cards can be factory-fitted. NOVRAM up to 512 kB is also available in the form of an optional Mini PCI plug-in card for fail-safe data storage.

TFT display

CF or CFast flash card easily accessible

Lithium battery easily accessible

On-board Ethernet adapter

Hard disk or SSD easily accessible

3½-inch motherboard

1 Mini PCI slot for fieldbus cards

Power supply 24 V DC, optionally with UPS

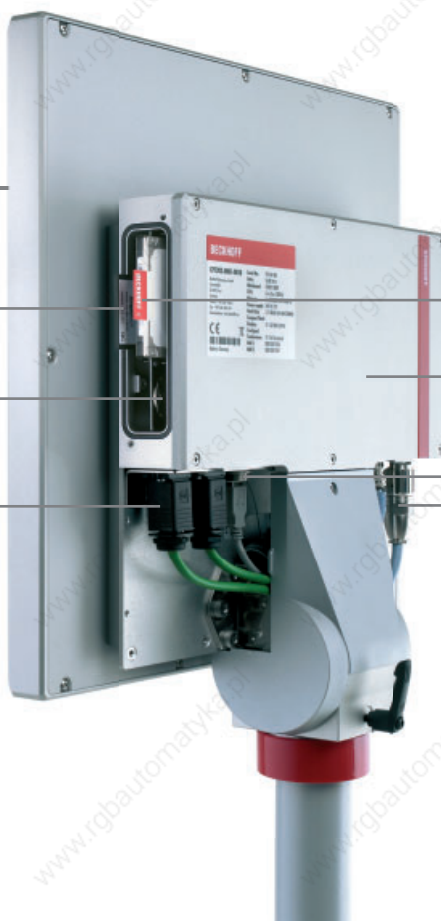

► www.beckhoff.com/CP72xx

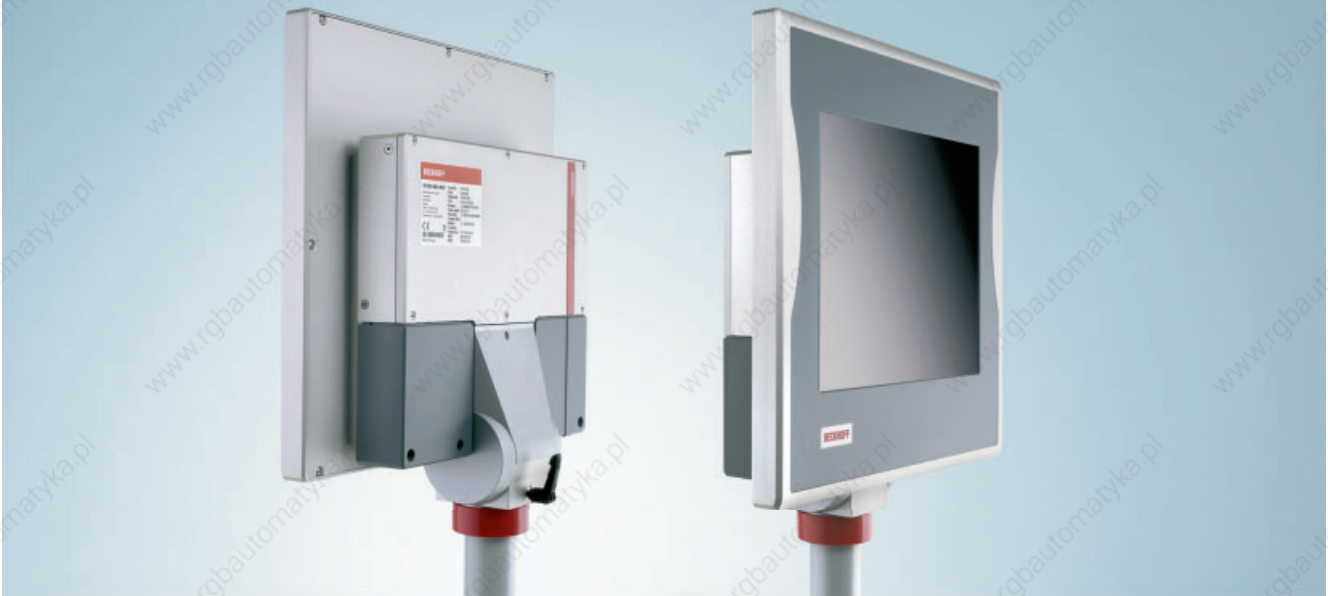

CP72xx | "Economy" Panel PC

The Industrial PC with mounting arm and 3½-inch motherboard

Ordering information	without touch screen	with single-touch screen	with touch pad
Display only			
12-inch display 800 x 600	CP7201-0000-xxxx	CP7201-0001-xxxx	
15-inch display 1024 x 768	CP7202-0000-xxxx	CP7202-0001-xxxx	
19-inch display 1280 x 1024	CP7203-0000-xxxx	CP7203-0001-xxxx	
24-inch display 1920 x 1200	CP7204-0000-xxxx	CP7204-0001-xxxx	
Display only, USB A socket in the front			
12-inch display 800 x 600	CP7201-0020-xxxx	CP7201-0021-xxxx	
15-inch display 1024 x 768	CP7202-0020-xxxx	CP7202-0021-xxxx	
19-inch display 1280 x 1024	CP7203-0020-xxxx	CP7203-0021-xxxx	
24-inch display 1920 x 1200	CP7204-0020-xxxx	CP7204-0021-xxxx	
With function keys			
12-inch display 800 x 600	CP7211-0000-xxxx	CP7211-0001-xxxx	
15-inch display 1024 x 768	CP7212-0000-xxxx	CP7212-0001-xxxx	
19-inch display 1280 x 1024	CP7213-0000-xxxx	CP7213-0001-xxxx	
Numeric keyboard			
12-inch display 800 x 600	CP7221-0000-xxxx	CP7221-0001-xxxx	CP7221-0002-xxxx
15-inch display 1024 x 768	CP7222-0000-xxxx	CP7222-0001-xxxx	CP7222-0002-xxxx
19-inch display 1280 x 1024	CP7223-0000-xxxx	CP7223-0001-xxxx	CP7223-0002-xxxx
Alphanumeric keyboard			
12-inch display 800 x 600	CP7231-0000-xxxx	CP7231-0001-xxxx	CP7231-0002-xxxx
15-inch display 1024 x 768	CP7232-0000-xxxx	CP7232-0001-xxxx	CP7232-0002-xxxx
19-inch display 1280 x 1024	CP7233-0000-xxxx	CP7233-0001-xxxx	CP7233-0002-xxxx
Alphanumeric keyboard with PLC keys on the sides			
15-inch display 1024 x 768	CP7242-0000-xxxx	CP7242-0001-xxxx	



Without keys



Function keys



Numeric keyboard



Alphanumeric keyboard

Alphanumeric keyboard
with PLC keys on the sides

CP72xx	CP72xx-xxxx-0010, -0020, -0030, -0040
Housing	Industrial PC with Control Panel for mounting arm installation
	rotatable mounting arm adapter for Rittal and Roolec mounting arm systems with 48 mm tube from top
	wiring area for up to 6 IP 65 connectors
	1 slot for one 2½-inch hard disk or SSD and 1 slot for one Compact Flash card
	lithium battery of the system clock, changeable from outside
	passive cooling through heat sink structure between Control Panel and add-on PC, internal fan for equal heat distribution to all the walls of the housing
	20 cm free space required around the PC for air circulation
	protection class IP 65
	operating temperature 0...45 °C

Features	CP72xx-xxxx-0010	CP72xx-xxxx-0020	CP72xx-xxxx-0030	CP72xx-xxxx-0040
Display	12-, 15-, 19- or 24-inch TFT display	12-, 15-, 19- or 24-inch TFT display	12-, 15-, 19- or 24-inch TFT display	12-, 15-, 19- or 24-inch TFT display
Processor	Intel® Core™ Duo or Core™2 Duo	Intel® Celeron® up to Core™2 Duo	Intel® Celeron® up to Core™2 Duo	up to Core™ i3/i5/i7 2 nd generation
Motherboard	3½-inch	3½-inch	3½-inch	3½-inch
Slots	1 Mini PCI slot	1 Mini PCI slot	1 Mini PCI slot	1 Mini PCI slot
Free slots	1 Mini PCI slot	1 Mini PCI slot	1 Mini PCI slot	1 Mini PCI slot
Max. card length	Mini PCI	Mini PCI	Mini PCI	Mini PCI
Memory	1...3 GB DDR2RAM	1...8 GB DDR3 RAM	1...8 GB DDR3 RAM	2...16 GB DDR3 RAM
Graphic adapter	on-board	on-board	on-board	integrated in the processor
Ethernet	2 on-board	2 on-board	2 on-board	2 on-board
Hard disks/flash	1 or 2 x 2½-inch HDD or SSD, 1 x 2½-inch HDD or SSD and CF card or 2 x CF card	1 or 2 x 2½-inch HDD or SSD, 1 x 2½-inch HDD or SSD and CF card or 2 x CF card	1 or 2 x 2½-inch HDD or SSD, 1 x 2½-inch HDD or SSD and 1 x CFast or 2 x CFast	1 or 2 x 2½-inch HDD or SSD, 1 x 2½-inch HDD or SSD and 1 x CFast or 2 x CFast
RAID 1	2 x 2½-inch HDD	2 x 2½-inch HDD	2 x 2½-inch HDD or 2 x CFast	2 x 2½-inch HDD or 2 x CFast
Power supply	24 V DC	24 V DC	24 V DC	24 V DC
Recommendation	not recommended for new projects	available	recommended for new projects	recommended for new projects
Further information	for further options, technical drawings, documentations, etc. see www.beckhoff.com/CP72xx			

CP77xx | Panel PC with Intel® Atom™

The CP77xx Panel PC series is designed for installation on a mounting arm. Control Panels form the front of the IP 65 Panel PC. The right display size and keyboard are thus available for every application. The CP77xx Industrial PCs represent a high-performance platform for machine construction and plant engineering applications that can be used in conjunction with TwinCAT automation software.

The PC can be equipped with a 6.5-, 12-, 15- or 19-inch LC display, as a monitor without keyboard or with different types of keyboards. Optionally, a touch screen or touch pad is available. In addition, a large number of push-button extensions are available.

Cooling is achieved directly via the rear panel of the Control Panel. No fan is required. The PC can be operated at up to 55 °C

ambient temperature. The case is optionally designed for direct wall mounting or for mounting arm installation. The mounting arm can be attached from above or below. If a mounting arm is used, the connection cables are fed through the mounting arm adapter attached centrally at the rear. Pre-assembled cables in various lengths are available for the Ethernet connections.



Front laminates



Without keys



Function keys



Numeric keyboard



Alphanumeric keyboard

The compact aluminium housing of the CP77xx Panel PCs is equipped with a Beckhoff motherboard for Intel® Atom™ 1.1 or 1.6 GHz.

Due to its two independent Gigabit Ethernet interfaces the CP77xx is ideally suited as a compact central processing unit for an EtherCAT control system.

Both Ethernet ports offer optimum performance for all tasks of the EtherCAT controller or for the connection of the higher-level network.

The CP77xx series Panel PCs are supplied with a 24 V power supply unit. With the optional 1-second UPS, capacitors integrated on the motherboard can maintain PC opera-

tion for a few seconds, so that key variables can be saved. The Compact Flash cards and the lithium battery for the system clock are located under a cover and accessible from the rear.

TFT display

1 serial interface RS232

Power supply 24 V DC

CF card easily accessible from the rear side

On-board dual Ethernet adapter

Lithium battery accessible from the rear side

CP motherboard



► www.beckhoff.com/CP77xx



CP77xx | Panel PC with Intel® Atom™

The compact Industrial PC with mounting arm

Ordering information	without touch screen	with single-touch screen	with touch pad
Display only			
6.5-inch display 640 x 480	CP7709-0000-xxxx	CP7709-0001-xxxx	
12-inch display 800 x 600	CP7701-0000-xxxx	CP7701-0001-xxxx	
15-inch display 1024 x 768	CP7702-0000-xxxx	CP7702-0001-xxxx	
19-inch display 1280 x 1024	CP7703-0000-xxxx	CP7703-0001-xxxx	
Display only, USB A socket in the front			
12-inch display 800 x 600	CP7701-0020-xxxx	CP7701-0021-xxxx	
15-inch display 1024 x 768	CP7702-0020-xxxx	CP7702-0021-xxxx	
19-inch display 1280 x 1024	CP7703-0020-xxxx	CP7703-0021-xxxx	
With function keys			
6.5-inch display 640 x 480	CP7719-0000-xxxx	CP7719-0001-xxxx	
12-inch display 800 x 600	CP7711-0000-xxxx	CP7711-0001-xxxx	
15-inch display 1024 x 768	CP7712-0000-xxxx	CP7712-0001-xxxx	
19-inch display 1280 x 1024	CP7713-0000-xxxx	CP7713-0001-xxxx	
Numeric keyboard			
6.5-inch display 640 x 480	CP7729-0000-xxxx	CP7729-0001-xxxx	
12-inch display 800 x 600	CP7721-0000-xxxx	CP7721-0001-xxxx	CP7721-0002-xxxx
15-inch display 1024 x 768	CP7722-0000-xxxx	CP7722-0001-xxxx	CP7722-0002-xxxx
19-inch display 1280 x 1024	CP7723-0000-xxxx	CP7723-0001-xxxx	CP7723-0002-xxxx
Alphanumeric keyboard			
12-inch display 800 x 600	CP7731-0000-xxxx	CP7731-0001-xxxx	CP7731-0002-xxxx
15-inch display 1024 x 768	CP7732-0000-xxxx	CP7732-0001-xxxx	CP7732-0002-xxxx
19-inch display 1280 x 1024	CP7733-0000-xxxx	CP7733-0001-xxxx	CP7733-0002-xxxx
Stainless steel housing		with single-touch screen	with single-touch screen, push-buttons and USB-socket
12-inch display 800 x 600		CP7701-1400-0030	CP7701-1401-0030
15-inch display 1024 x 768		CP7702-1400-0030	CP7702-1401-0030
19-inch display 1280 x 1024		CP7703-1400-0030	CP7703-1401-0030



Stainless steel finish



Without keys



Function keys



Numeric keyboard



Alphanumeric keyboard

CP77xx	CP77xx-xxxx-0020, -0030
Housing	TFT display in four sizes
	aluminium housing, protection class IP 65
	front laminate in four variants
	special keys identified by slide-in labels
	operating temperature 0...55 °C
	for mounting 4 M6 x 18 mm threaded holes in the backplane

Features	CP77xx-xxxx-0020	CP77xx-xxxx-0030
Display	6.5, 12-, 15- or 19-inch TFT display	6.5, 12-, 15- or 19-inch TFT display
Processor	AMD LX800	Intel® Atom™
Motherboard	CP format	CP format
Memory	256 MB DDR RAM	1...2 GB DDR2RAM
Graphic adapter	on-board	on-board
Ethernet	2 on-board	2 on-board
Hard disks/flash	CF card	CF card
Power supply	24 V DC	24 V DC
Recommendation	available	available
Options	–	stainless steel housing with flush-mounted touch screen for CP7701, CP7702 or CP7703
Further information	for further options, technical drawings, documentations, etc. see www.beckhoff.com/CP77xx	

C33xx | 19-inch Panel PC series

The 19-inch Panel PC series C33xx, fitted with Intel® Celeron®, Intel® Core™2 Duo or Core™ i3/i5/i7 of the 2nd generation on a standard ATX motherboard, offers controllers of the highest performance class, with a 12- or 15-inch TFT display, optionally with alphanumeric PC keyboard or numeric keyboard, with a touch screen or a touch pad.

The housing can be installed and re-fitted from the front. A CD/DVD-ROM or multi DVD drive can be fitted behind the lockable front cover. It is also possible to fit USB connection sockets for keyboard and mouse under the front cover, permitting commissioning and software updates with the aid of standard input devices. In this case the connected

keyboard operates in parallel with the front keyboard. The mouse works in parallel with the touch screen or touch pad. Additionally, a second 3½-inch hard disk can be installed. The on-board RAID 1 controller can mirror two SATA hard disks.

Card holders for the plug-in cards generate insensitivity to shocks and vibrations.





C3320



C3330



C3340



C3350

The card holders can be fixed and removed without tools.

The Industrial PC corresponds to the ATX standard, and is therefore compatible with all new PC components.

The type plate provides detailed information regarding the PC's configuration.

The construction of the housing has been designed to allow individual changes, and many features can be optimised for the application.

A variety of front panels can be combined with the computer core. Although the front panels have different heights,

the computer core is always made to fit eight rack units. It is possible that the front panel will extend one or two rack units further at the lower side. The fitting cut-out required for installation is always the same.

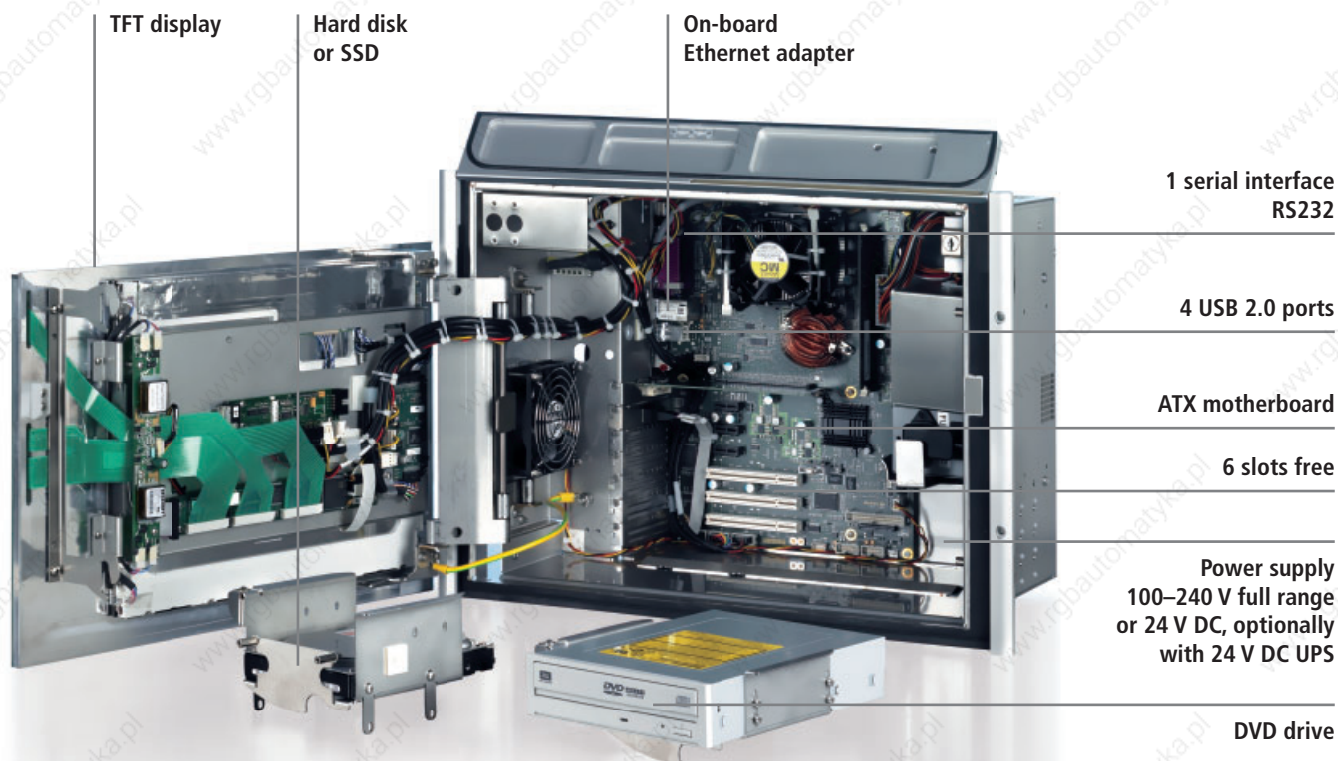

► www.beckhoff.com/C33xx



C3320 | 19-inch Panel PC

C3320	C3320-0030, -0040, -0050
Housing	19-inch built-in housing, 8 rack units
	7-slot processor core for ATX motherboard
	PC to be opened from the front; all components easily accessible from the front
	3 PCI slots for full-length plug-in cards and 4 PCI Express slots for up to 240 mm long plug-in cards
	card holders, actuated without tools
	protection class front side IP 65, rear side IP 20
	operating temperature 0...55 °C
	weight of the basic configuration 18 kg (39.8 lbs)
	dimensions (W x H x D) 482.7 x 355 x 282 mm (19" x 14" x 11.1"), depth behind front 261 mm (10.4")

Features	C3320-0030	C3320-0040	C3320-0050
Display	12-inch TFT display, resolution 800 x 600	12-inch TFT display, resolution 800 x 600	12-inch TFT display, resolution 800 x 600
Touch screen	single-touch as an option	single-touch as an option	single-touch as an option
Processor	Intel® Core™ Duo or Core™2 Duo	Intel® Celeron® up to Core™2 Duo	up to Core™ i3/i5/i7 2 nd generation
Motherboard	ATX	ATX	ATX
Slots	7	7	7
Free slots	3 PCI and 3 PCIe x1	3 PCI and 3 PCIe x1	3 PCI, 2 PCIe x1, 1 PCIe x4 and 1 PCIe x16
Max. card length	3 x fullsize, 3 x 240 mm	3 x fullsize, 3 x 240 mm	3 x fullsize, 4 x 240 mm
Memory	1...3 GB DDR2RAM	1...8 GB DDR3 RAM	2...16 GB DDR3 RAM
Graphic adapter	on-board	on-board	integrated in the processor
Ethernet	on-board	on-board	on-board
Hard disks/flash	1–2 x 3½-inch HDD or 2½-inch SSD	1–2 x 3½-inch HDD or 2½-inch SSD	1–2 x 3½-inch HDD or 2½-inch SSD
RAID 1	2 x 3½-inch HDD	2 x 3½-inch HDD	2 x 3½-inch HDD
Possible disk drives	CD/DVD-ROM or multi-DVD	CD/DVD-ROM or multi-DVD	CD/DVD-ROM or multi-DVD
Power supply	100...240 V AC or 24 V DC	100...240 V AC or 24 V DC	100...240 V AC or 24 V DC
Recommendation	not recommended for new projects	available	recommended for new projects
Further information	for further options, technical drawings, documentations, etc. see www.beckhoff.com/C3320		



C3330 | 19-inch Panel PC

C3330	C3330-0030, -0040, -0050
Housing	19-inch built-in housing, 9 rack units
	7-slot processor core for ATX motherboard
	PC to be opened from the front; all components easily accessible from the front
	3 PCI slots for full-length plug-in cards and 4 PCI Express slots for up to 240 mm long plug-in cards card holders, actuated without tools
	protection class front side IP 65, rear side IP 20
	operating temperature 0...55 °C
	weight of the basic configuration 18.5 kg (40.9 lbs)
	dimensions (W x H x D) 482.7 x 400 x 282 mm (19" x 15.7" x 11.1"), depth behind front 261 mm (10.4")

Features	C3330-0030	C3330-0040	C3330-0050
Display	12-inch TFT display, resolution 800 x 600	12-inch TFT display, resolution 800 x 600	12-inch TFT display, resolution 800 x 600
Touch screen	single-touch as an option	single-touch as an option	single-touch as an option
Processor	Intel® Core™ Duo or Core™2 Duo	Intel® Celeron® up to Core™2 Duo	up to Core™ i3/i5/i7 2 nd generation
Motherboard	ATX	ATX	ATX
Slots	7	7	7
Free slots	3 PCI and 3 PCIe x1	3 PCI and 3 PCIe x1	3 PCI, 2 PCIe x1, 1 PCIe x4 and 1 PCIe x16
Max. card length	3 x fullsize, 3 x 240 mm	3 x fullsize, 3 x 240 mm	3 x fullsize, 4 x 240 mm
Memory	1...3 GB DDR2RAM	1...8 GB DDR3 RAM	2...16 GB DDR3 RAM
Graphic adapter	on-board	on-board	integrated in the processor
Ethernet	on-board	on-board	on-board
Hard disks/flash	1-2 x 3½-inch HDD or 2½-inch SSD	1-2 x 3½-inch HDD or 2½-inch SSD	1-2 x 3½-inch HDD or 2½-inch SSD
RAID 1	2 x 3½-inch HDD	2 x 3½-inch HDD	2 x 3½-inch HDD
Possible disk drives	CD/DVD-ROM or multi-DVD	CD/DVD-ROM or multi-DVD	CD/DVD-ROM or multi-DVD
Power supply	100...240 V AC or 24 V DC	100...240 V AC or 24 V DC	100...240 V AC or 24 V DC
Recommendation	not recommended for new projects	available	recommended for new projects
Further information	for further options, technical drawings, documentations, etc. see www.beckhoff.com/C3330		



C3340 | 19-inch Panel PC

C3340	C3340-0030, -0040, -0050
Housing	19-inch built-in housing, 8 rack units
	7-slot processor core for ATX motherboard
	PC to be opened from the front; all components easily accessible from the front
	3 PCI slots for full-length plug-in cards and 4 PCI Express slots for up to 240 mm long plug-in cards
	card holders, actuated without tools
	protection class front side IP 65, rear side IP 20
	operating temperature 0...55 °C
	weight of the basic configuration 18.5 kg (40.9 lbs)
	dimensions (W x H x D) 482.7 x 355 x 282 mm (19" x 14" x 11.1"), depth behind front 261 mm (10.4")

Features	C3340-0030	C3340-0040	C3340-0050
Display	15-inch TFT display, resolution 1024 x 768	15-inch TFT display, resolution 1024 x 768	15-inch TFT display, resolution 1024 x 768
Touch screen	single-touch as an option	single-touch as an option	single-touch as an option
Processor	Intel® Core™ Duo or Core™2 Duo	Intel® Celeron® up to Core™2 Duo	up to Core™ i3/i5/i7 2 nd generation
Motherboard	ATX	ATX	ATX
Slots	7	7	7
Free slots	3 PCI and 3 PCIe x1	3 PCI and 3 PCIe x1	3 PCI, 2 PCIe x1, 1 PCIe x4 and 1 PCIe x16
Max. card length	3 x fullsize, 3 x 240 mm	3 x fullsize, 3 x 240 mm	3 x fullsize, 4 x 240 mm
Memory	1...3 GB DDR2RAM	1...8 GB DDR3 RAM	2...16 GB DDR3 RAM
Graphic adapter	on-board	on-board	integrated in the processor
Ethernet	on-board	on-board	on-board
Hard disks/flash	1–2 x 3½-inch HDD or 2½-inch SSD	1–2 x 3½-inch HDD or 2½-inch SSD	1–2 x 3½-inch HDD or 2½-inch SSD
RAID 1	2 x 3½-inch HDD	2 x 3½-inch HDD	2 x 3½-inch HDD
Possible disk drives	CD/DVD-ROM or multi-DVD	CD/DVD-ROM or multi-DVD	CD/DVD-ROM or multi-DVD
Power supply	100...240 V AC or 24 V DC	100...240 V AC or 24 V DC	100...240 V AC or 24 V DC
Recommendation	not recommended for new projects	available	recommended for new projects
Further information	for further options, technical drawings, documentations, etc. see www.beckhoff.com/C3340		



C3350 | 19-inch Panel PC

C3350	C3350-0030, -0040, -0050
Housing	19-inch built-in housing, 10 rack units
	7-slot processor core for ATX motherboard
	PC to be opened from the front; all components easily accessible from the front
	3 PCI slots for full-length plug-in cards and 4 PCI Express slots for up to 240 mm long plug-in cards card holders, actuated without tools
	protection class front side IP 65, rear side IP 20
	operating temperature 0...55 °C
	weight of the basic configuration 19 kg (42 lbs)
	dimensions (W x H x D) 482.7 x 444 x 282 mm (19" x 17.5" x 11.1"), depth behind front 261 mm (10.4")

Features	C3350-0030	C3350-0040	C3350-0050
Display	15-inch TFT display, resolution 1024 x 768	15-inch TFT display, resolution 1024 x 768	15-inch TFT display, resolution 1024 x 768
Touch screen	single-touch as an option	single-touch as an option	single-touch as an option
Processor	Intel® Core™ Duo or Core™2 Duo	Intel® Celeron® up to Core™2 Duo	up to Core™ i3/i5/i7 2 nd generation
Motherboard	ATX	ATX	ATX
Slots	7	7	7
Free slots	3 PCI and 3 PCIe x1	3 PCI and 3 PCIe x1	3 PCI, 2 PCIe x1, 1 PCIe x4 and 1 PCIe x16
Max. card length	3 x fullsize, 3 x 240 mm	3 x fullsize, 3 x 240 mm	3 x fullsize, 4 x 240 mm
Memory	1...3 GB DDR2RAM	1...8 GB DDR3 RAM	2...16 GB DDR3 RAM
Graphic adapter	on-board	on-board	integrated in the processor
Ethernet	on-board	on-board	on-board
Hard disks/flash	1-2 x 3½-inch HDD or 2½-inch SSD	1-2 x 3½-inch HDD or 2½-inch SSD	1-2 x 3½-inch HDD or 2½-inch SSD
RAID 1	2 x 3½-inch HDD	2 x 3½-inch HDD	2 x 3½-inch HDD
Possible disk drives	CD/DVD-ROM or multi-DVD	CD/DVD-ROM or multi-DVD	CD/DVD-ROM or multi-DVD
Power supply	100...240 V AC or 24 V DC	100...240 V AC or 24 V DC	100...240 V AC or 24 V DC
Recommendation	not recommended for new projects	available	recommended for new projects
Further information	for further options, technical drawings, documentations, etc. see www.beckhoff.com/C3350		

C36xx | Panel PC series

The Panel PC series C36xx, fitted with Intel® Celeron®, Intel® Core™2 Duo or Core™ i3/i5/i7 processors of the 2nd generation on an ATX motherboard, offers controllers of the highest performance class with 12- or 15-inch TFT display, as a display/computer unit optionally with touch screen. The housing is opened from the rear.

All components can be reached quickly and easily.

A CD/DVD-ROM for commissioning and software updates or a multi DVD or Blu-ray multi DVD drive for data backup are accessible from the rear side. The drives can be removed without tools once the housing has been opened. Card holders for the plug-in

cards generate insensitivity to shocks and vibrations. The card holders can be fixed and removed without tools.

The type plate on the rear provides detailed information regarding the PC's configuration. Data on the function and type is listed for the fitted plug-in cards. Data about drives indicates not just the





C3620



C3640

manufacturer and type, but also provides information about type of connection and jumpers.

The construction of the housing of the C36xx series accords with the ATX standard, thus ensuring long-term compatibility with any PC components that will appear in the next few years. If, in a few years, the Indus-

trial PC needs to be upgraded, you swap the motherboard, the processor, the memory or the hard disk, but the housing, display and touch screen remain unchanged, being compatible with the technology of the future. The computing power can be upgraded with anything that the PC market has to offer in the highest performance class.

Customer-specific design

Beckhoff designs Industrial PCs in a modular way and has a long experience in customising designs to specific needs, e.g. for individual artwork and company logo on the front. An Industrial PC should express Corporate Identity.

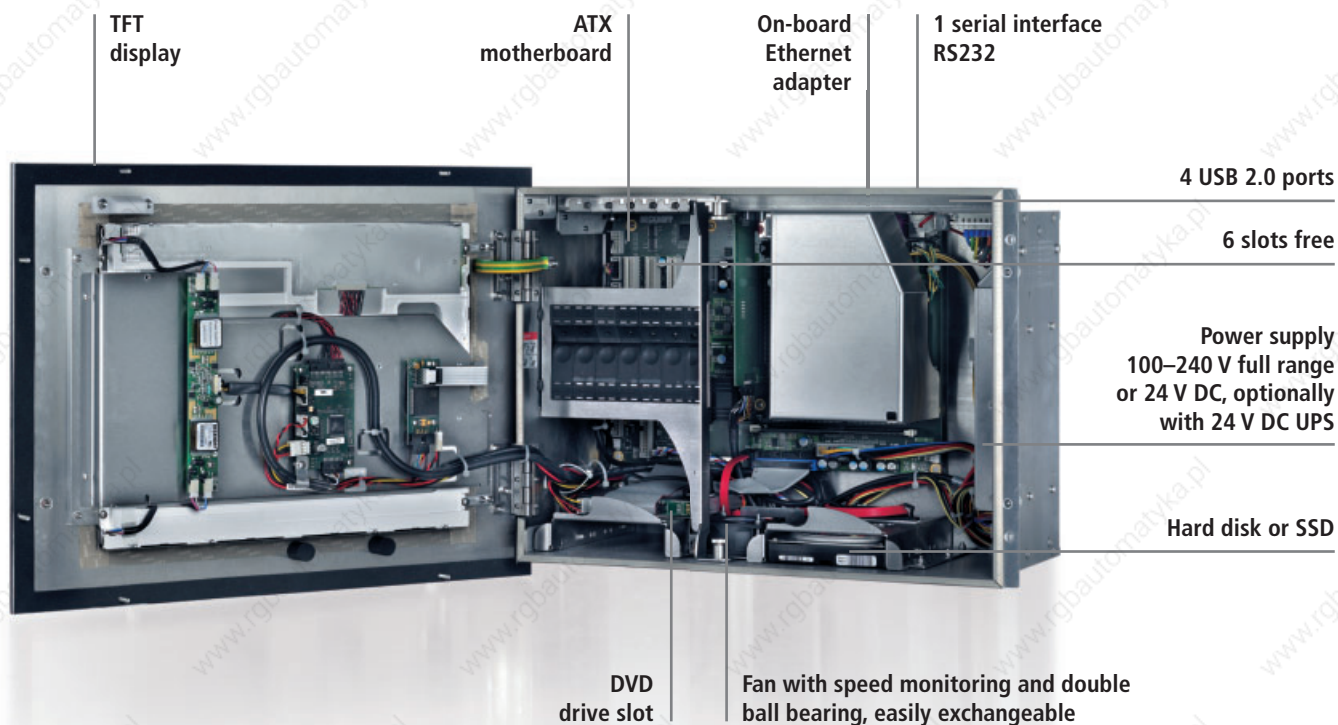

► www.beckhoff.com/C36xx



C3620 | Panel PC

C3620	C3620-0030, -0040, -0050
Housing	built-in housing, 388 x 324 mm 7-slot processor core for ATX motherboard PC to be opened from the back side all components easily accessible 7 slots for up to 220 mm long plug-in cards card holders, actuated without tools protection class front side IP 65, rear side IP 20 operating temperature 0...55 °C weight of the basic configuration 11.5 kg (25.4 lbs) dimensions (W x H x D) 388 x 324 x 201 mm (15.3" x 12.8" x 7.9"), depth behind front 193 mm (7.6")

Features	C3620-0030	C3620-0040	C3620-0050
Display	12-inch TFT display, resolution 800 x 600	12-inch TFT display, resolution 800 x 600	12-inch TFT display, resolution 800 x 600
Touch screen	single-touch as an option	single-touch as an option	single-touch as an option
Processor	Intel® Core™ Duo or Core™2 Duo	Intel® Celeron® up to Core™2 Duo	up to Core™ i3/i5/i7 2 nd generation
Motherboard	ATX	ATX	ATX
Slots	7	7	7
Free slots	3 PCI and 3 PCIe x1	3 PCI and 3 PCIe x1	3 PCI, 2 PCIe x1, 1 PCIe x4 and 1 PCIe x16
Max. card length	7 x 220 mm	7 x 220 mm	7 x 220 mm
Memory	1...3 GB DDR2RAM	1...8 GB DDR3 RAM	2...16 GB DDR3 RAM
Graphic adapter	on-board	on-board	integrated in the processor
Ethernet	on-board	on-board	on-board
Hard disks/flash	1 x 3½-inch HDD or 2½-inch SSD	1 x 3½-inch HDD or 2½-inch SSD	1 x 3½-inch HDD or 2½-inch SSD
RAID 1	–	–	–
Possible disk drives	slimline CD/DVD-ROM or multi DVD	slimline CD/DVD-ROM or multi DVD	slimline CD/DVD-ROM or multi DVD
Power supply	100...240 V AC or 24 V DC	100...240 V AC or 24 V DC	100...240 V AC or 24 V DC
Recommendation	not recommended for new projects	available	recommended for new projects
Further information	for further options, technical drawings, documentations, etc. see www.beckhoff.com/C3620		



C3640 | Panel PC

C3640	C3640-0030, -0040, -0050
Housing	built-in housing, 470 x 348 mm
	7-slot processor core for ATX motherboard
	PC to be opened from the back side
	all components easily accessible
	7 slots for up to 235 mm long plug-in cards
	card holders, actuated without tools
	protection class front side IP 65, rear side IP 20
	operating temperature 0...55 °C
	weight of the basic configuration 14.1 kg (31.1 lbs)
	dimensions (W x H x D) 470 x 348 x 199 mm (18.5" x 13.7" x 7.8"), depth behind front 191 mm (7.5")

Features	C3640-0030	C3640-0040	C3640-0050
Display	15-inch TFT display, resolution 1024 x 768	15-inch TFT display, resolution 1024 x 768	15-inch TFT display, resolution 1024 x 768
Touch screen	single-touch as an option	single-touch as an option	single-touch as an option
Processor	Intel® Core™ Duo or Core™2 Duo	Intel® Celeron® up to Core™2 Duo	up to Core™ i3/i5/i7 2 nd generation
Motherboard	ATX	ATX	ATX
Slots	7	7	7
Free slots	3 PCI and 3 PCIe x1	3 PCI and 3 PCIe x1	3 PCI, 2 PCIe x1, 1 PCIe x4 and 1 PCIe x16
Max. card length	7 x 235 mm	7 x 235 mm	7 x 235 mm
Memory	1...3 GB DDR2RAM	1...8 GB DDR3 RAM	2...16 GB DDR3 RAM
Graphic adapter	on-board	on-board	integrated in the processor
Ethernet	on-board	on-board	on-board
Hard disks/flash	1-2 x 3½-inch HDD or 2½-inch SSD	1-2 x 3½-inch HDD or 2½-inch SSD	1-2 x 3½-inch HDD or 2½-inch SSD
RAID 1	2 x 3½-inch HDD	2 x 3½-inch HDD	2 x 3½-inch HDD
Possible disk drives	slimline CD/DVD-ROM or multi DVD	slimline CD/DVD-ROM or multi DVD	slimline CD/DVD-ROM or multi DVD
Power supply	100...240 V AC or 24 V DC	100...240 V AC or 24 V DC	100...240 V AC or 24 V DC
Recommendation	not recommended for new projects	available	recommended for new projects
Further information	for further options, technical drawings, documentations, etc. see www.beckhoff.com/C3640		

Control cabinet Industrial PCs



C69xx | Control cabinet Industrial PC

Compact IPC wonders for control cabinets

- 3½-inch motherboard
- protection class IP 20
- operating temperature range: 0...55 °C
- all connections on the front

See page **122**

► www.beckhoff.com/Control-cabinet-PC



C5xxx | 19-inch slide-in Industrial PC

- slot, ATX or 3½-inch motherboard
- protection class IP 20
- operating temperature range: 0...55 °C

See page **86**

C61xx | Control cabinet Industrial PC

- slot or ATX motherboard
- protection class IP 20
- operating temperature range: 0...55 °C

See page **92**

C62xx | Control cabinet Industrial PC

- slot or ATX motherboard
- protection class IP 20
- operating temperature range: 0...55 °C

See page **98**

C63xx | Control cabinet Industrial PC

- slot motherboard
- protection class IP 20
- operating temperature range: with fan 0...55 °C, fanless 0...45 °C

See page **104**



C65xx | Fanless built-in Industrial PC

The Industrial PC for more flexibility

- 3½-inch motherboard
- protection class: outside IP 67, inside IP 20
- operating temperature range: outside 0...45 °C, inside 0...55 °C

See page **110**



C66xx | Control cabinet Industrial PC

The power pack for big automation tasks

- ATX motherboard
- protection class IP 20
- operating temperature range: 0...55 °C
- all connections on the top

See page **118**

C5xxx | Industrial PC series for 19-inch rack installation

The 19-inch rack mount Industrial PC series C51xx, equipped with Intel® Core™ Duo or Core™2 Duo on a slot motherboard or with Intel® Celeron®, Intel® Core™2 Duo or Core™ i3/i5/i7 of the 2nd generation on an ATX motherboard, offers maximum performance class controls. The 19-inch slide-in housing measures only four rack units, yet

has plenty of internal space for expansions of any form. A CD/DVD-ROM or multi DVD drive can be fitted behind the lockable front door.

The type plate provides detailed information regarding the PC's configuration. Carefully designed ventilation creates a slight excess pressure inside the housing, effectively preventing the entry of dust. A stable card

holder generates insensitivity to shocks and vibrations. A C51xx series Industrial PC and a Control Panel as its operating unit create an ideal combination.

The C5210 19-inch slide-in Industrial PC measures only one height unit. This IPC has an Intel® Celeron®, Intel® Core™2 Duo or Core™ i3/i5/i7 processor of the 2nd genera-





C5101

tion on a 3½-inch motherboard with on-board RAID controller and two SATA 3½-inch hard drive removable frames.

The combination of industrially-capable performance and functionality with an extremely flat design makes the C5210 particularly well-suited for space-saving applications. The low installation height is made



C5102

possible with the Beckhoff 3½-inch motherboards. The motherboard is equipped with a multitude of on-board interfaces, such as two Gigabit Ethernet ports, a DVI and a COM port as well as four USB ports. Further COM or USB ports as well as a sound interface and a second DVI connection can be led out as an option. The C5210 can be extended with



C5210

two PCIe modules or a Mini PCI card. A DVD-ROM or multi DVD drive can be optionally installed behind the front flap. The following operating systems are offered for the 19-inch Industrial PC: Windows Embedded Standard, Windows XP, Windows 7 or Windows 2008 Server.

On-board Ethernet adapter

6 free slots

ATX motherboard

Fan with double ball bearing, easily exchangeable

Power supply 100–240 V full range or 24 V DC, optionally with 24 V DC UPS

1 serial interface RS232

4 USB 2.0 ports

DVD drive slot

Optional removable frame for hard disks

Hard disk or SSD

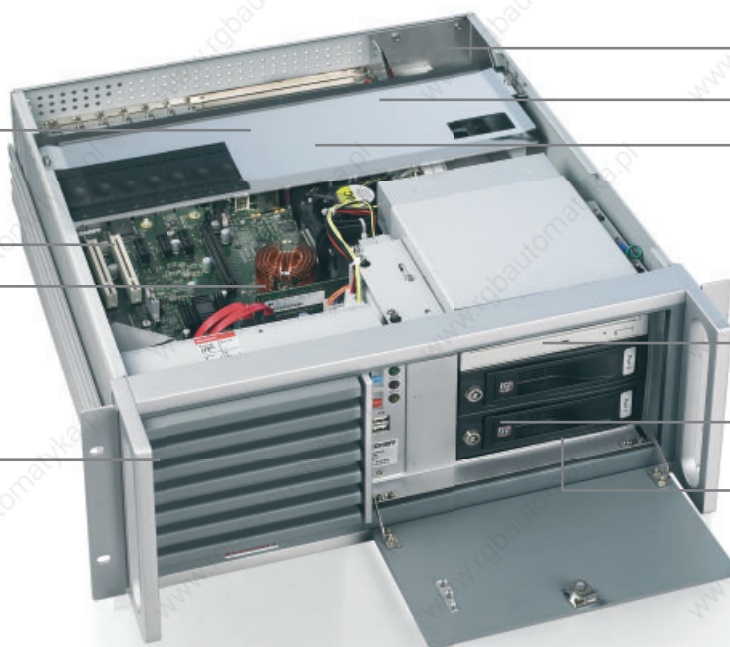

► www.beckhoff.com/C5xxx



C5101 | 19-inch slide-in Industrial PC

C5101	C5101-0030
Housing	14-slot slide-in housing for 19-inch racks, 4 rack units
	lockable front flap
	card holders
	protection class IP 60 when operating
	operating temperature 0...55 °C
	weight of the basic configuration 17.0 kg (37.5 lbs)
	dimensions (W x H x D) 483 x 177 x 500 mm (19" x 7" x 19.5")

Features	C5101-0030
Processor	Intel® Core™ Duo or Core™2 Duo
Motherboard	passive backplane
Slots	14
Free slots	11 PCI
Max. card length	8 x fullsize, 6 x 190 mm
Memory	1...3 GB DDR2RAM
Graphic adapter	on-board
Ethernet	2 on-board
Hard disks/flash	1-3 x 3½-inch HDD or 2½-inch SSD
Possible disk drives	CD/DVD-ROM or multi-DVD
Power supply	100...240 V AC or 24 V DC
Recommendation	not recommended for new projects
Further information	for further options, technical drawings, documentations, etc. see www.beckhoff.com/C5101



C5102 | 19-inch slide-in Industrial PC

C5102	C5102-0030, -0040, -0050
Housing	7-slot slide-in housing ATX for 19-inch racks, 4 rack units all slots for full-length plug-in cards lockable front flap card holders protection class IP 60 when operating operating temperature 0...55 °C weight of the basic configuration 17.0 kg (37.5 lbs) dimensions (W x H x D) 483 x 177 x 500 mm (19" x 7" x 19.5")

Features	C5102-0030	C5102-0040	C5102-0050
Processor	Intel® Core™ Duo or Core™2 Duo	Intel® Celeron® up to Core™2 Duo	up to Core™ i3/i5/i7 2 nd generation
Motherboard	ATX	ATX	ATX
Slots	7	7	7
Free slots	3 PCI, 3 PCIe x1 and 1 PCIe x16 graphic card slot	3 PCI, 3 PCIe x1 and 1 PCIe x16 graphic card slot	3 PCI, 2 PCIe x1, 1 PCIe x4 and 1 PCIe x16
Max. card length	7 x fullsize	7 x fullsize	7 x fullsize
Memory	1...3 GB DDR2RAM	1...8 GB DDR3 RAM	2...16 GB DDR3 RAM
Graphic adapter	on-board	on-board	integrated in the processor
Ethernet	on-board	on-board	on-board
Hard disks/flash	1-3 x 3½-inch HDD or 2½-inch SSD	1-3 x 3½-inch HDD or 2½-inch SSD	1-3 x 3½-inch HDD or 2½-inch SSD
RAID 1	2 x 3½-inch HDD	2 x 3½-inch HDD	2 x 3½-inch HDD
Possible disk drives	CD/DVD-ROM or multi-DVD	CD/DVD-ROM or multi-DVD	CD/DVD-ROM or multi-DVD
Power supply	100...240 V AC or 24 V DC	100...240 V AC or 24 V DC	100...240 V AC or 24 V DC
Recommendation	not recommended for new projects	available	recommended for new projects
Further information	for further options, technical drawings, documentations, etc. see www.beckhoff.com/C5102		



C5210 | 19-inch slide-in Industrial PC

C5210	C5210-0000, -0010
Housing	slide-in housing for 19-inch racks, 1 rack unit
	all drives accessible from the front
	2 removable frames for hard disks
	1 DVD drive slot, 2 USB sockets, reset key and ATX key behind a lockable front flap
	status LEDs
	all connectors at the rear side
	2 PCIe module slots to plug-in Beckhoff PCIe modules or to lead out interfaces of the motherboard ex factory
	protection class IP 20
	operating temperature 0...55 °C
	dimensions (W x H x D) 482.7 x 44 x 493.8 mm (19" x 1.7" x 19.44")
	depth behind the front 471.3 mm (18.56")

Features	C5210-0000	C5210-0010
Processor	Intel® Celeron® up to Core™2 Duo	up to Core™ i3/i5/i7 2 nd generation
Motherboard	3½-inch	3½-inch
Slots	1 Mini PCI and 2 PCIe modules	1 Mini PCI and 2 PCIe modules
Free slots	2 PCIe	2 PCIe
Max. card length	–	–
Memory	1...8 GB DDR3 RAM	2...16 GB DDR3 RAM
Graphic adapter	on-board	integrated in the processor
Ethernet	2 on-board	2 on-board
Hard disks/flash	1–2 x 3½-inch HDD	1–2 x 3½-inch HDD
RAID 1	2 x 3½-inch HDD	2 x 3½-inch HDD
Possible disk drives	CD/DVD-ROM or multi-DVD	CD/DVD-ROM or multi-DVD
Power supply	100...240 V AC or 24 V DC	100...240 V AC or 24 V DC
Recommendation	available	recommended for new projects
Further information	for further options, technical drawings, documentations, etc. see www.beckhoff.com/C5210	



C61xx | Industrial PC series for control cabinet installation

The C61xx control cabinet PC series comprises five devices of different sizes, all equipped with maximum performance class components with Intel® Core™ Duo or Core™2 Duo on a slot motherboard or with Intel® Celeron®, Intel® Core™2 Duo or Core™ i3/i5/i7 of the 2nd generation on an ATX motherboard. The series provides the appropriate Industrial PC for every application, according to the available installation space. All the PCs in the C61xx series are

constructed according to a uniform plan, optimised for the exploitation of available space and easy accessibility of all components.

The construction of the housing for the C61xx series ensures long-term compatibility with any new PC components that appear over the next few years. If, in a few years, the Industrial PC needs to be upgraded, you swap the motherboard, the processor, the memory or the hard disk, but the housing

remains unchanged and is compatible with the technology of the future.

All the PC's connections face upwards, so that the connecting cable can be taken directly to the wiring channel. The side walls are completely passive and allow the Industrial PC to be fitted immediately next to other control cabinet devices.

The housing permits fast access to the fitted components. After removing the front cover, plug-in cards and drives are freely





C6110

C6120

C6130

C6140

C6150

accessible. Hard disks are held by spring-loaded ball catches and can be removed in a single action. Three screws must be undone, after which the PC's inner chassis, to which all the components are attached, can be removed from the outer housing. The inner chassis can be placed on a table in any orientation for maintenance purposes. When removed, the inner chassis still has the full function of a PC and can be operated with a standard monitor and a standard keyboard.

The C61xx series PCs are supplied with a 100...240 V AC full range or 24 V DC power supply unit. An industrial latching socket strip is used for the power supply. A CD/DVD-ROM or multi DVD drive can be fitted. Card holders for the plug-in cards generate insensitivity to shocks and vibrations. The card holders can be fixed and removed without tools.

Additional slot brackets for C6110, C6120 and C6130 offer room to connect interfaces to the outside without occupy-

ing the space for real slots. A type plate is located on the front cover behind an inspection window, giving detailed information about the configuration of the PC. The construction of the housing has been designed to allow individual adaptation, and many features can be adjusted for your application.

4 USB 2.0 ports

1 serial interface RS232

On-board Ethernet adapter

Power supply 100–240 V full range or 24 V DC, optionally with 24 V DC UPS

All connections on the top

6 free slots

Fan with speed monitoring and double ball bearing, easily exchangeable

ATX motherboard

Hard disk or SSD

Passive side wall: fitting possible immediately next to other devices

DVD drive slot



► www.beckhoff.com/C61xx



C6110



C6120

C6110, C6120 | Control cabinet Industrial PC

C6110, C6120	C6110-0030	C6120-0030
Housing	4-slot Industrial PC for space-saving control cabinet installation	5-slot Industrial PC for space-saving control cabinet installation
	1 PCI slot for plug-in cards with a length of up to 190 mm	all slots for full-length plug-in cards
	drives and plug-in cards easily accessible	drives and plug-in cards easily accessible
	all connectors on the top	all connectors on the top
	detailed PC configuration information on the front	detailed PC configuration information on the front
	status LEDs and protected reset key	status LEDs and protected reset key
	card holders, actuated without tools	card holders, actuated without tools
	protection class IP 20	protection class IP 20
	operating temperature 0...55 °C	operating temperature 0...55 °C
	weight of the basic configuration 7 kg (15.4 lbs)	weight of the basic configuration 9 kg (19.8 lbs)
	compact dimensions (W x H x D)	compact dimensions (W x H x D)
	180 x 287 x 250 mm (7.1" x 11.3" x 9.9")	195 x 423 x 250 mm (7.7" x 16.7" x 9.9")

Features	C6110-0030	C6120-0030
Processor	Intel® Core™ Duo or Core™2 Duo	Intel® Core™ Duo or Core™2 Duo
Motherboard	passive backplane	passive backplane
Slots	4	5
Free slots	1 PCI	2 PCI
Max. card length	4 x 190 mm	5 x fullsize
Memory	1...3 GB DDR2RAM	1...3 GB DDR2RAM
Graphic adapter	on-board	on-board
Ethernet	2 on-board	2 on-board
Hard disks/flash	1 x 3½-inch HDD and/or 2½-inch SSD	1–2 x 3½-inch HDD or 2½-inch SSD
Possible disk drives	–	CD/DVD-ROM or multi-DVD
Power supply	100...240 V AC or 24 V DC	100...240 V AC or 24 V DC
Recommendation	not recommended for new projects	not recommended for new projects
Further information	for further options, technical drawings, documentations, etc. see www.beckhoff.com/C6110	



C6130 | Control cabinet Industrial PC

C6130	C6130-0030
Housing	8-slot Industrial PC for control cabinet installation
	2 PCI slots for full-length plug-in cards and 4 PCI slots for up to 290 mm long plug-in cards
	drives and plug-in cards easily accessible
	all connectors on the top
	detailed PC configuration information on the front
	status LEDs and protected reset key
	card holders, actuated without tools
	protection class IP 20
	operating temperature 0...55 °C
	weight of the basic configuration 12 kg (26.5 lbs)
	dimensions (W x H x D) 295 x 423 x 250 mm (11.6" x 16.7" x 9.9")

Features	C6130-0030
Processor	Intel® Core™ Duo or Core™2 Duo
Motherboard	passive backplane
Slots	8
Free slots	6 PCI
Max. card length	4 x fullsize, 4 x 250 mm
Memory	1...3 GB DDR2RAM
Graphic adapter	on-board
Ethernet	2 on-board
Hard disks/flash	1-3 x 3½-inch HDD or 2½-inch SSD
Possible disk drives	CD/DVD-ROM or multi-DVD
Power supply	100...240 V AC or 24 V DC
Recommendation	not recommended for new projects
Further information	for further options, technical drawings, documentations, etc. see www.beckhoff.com/C6130



C6140 | Control cabinet Industrial PC

C6140	C6140-0030, -0040, -0050
Housing	7-slot ATX Industrial PC for control cabinet installation
	3 PCI slots for up to 270 mm long plug-in cards and 4 PCI Express slots for up to 240 mm long plug-in cards
	drives and plug-in cards easily accessible
	all connectors on the top
	detailed PC configuration information on the front
	status LEDs and protected reset key
	card holders, actuated without tools
	protection class IP 20
	operating temperature 0...55 °C
	weight of the basic configuration 14 kg (30.9 lbs)
	dimensions (W x H x D) 383 x 362 x 265 mm (14.9" x 14.1" x 10.5")

Features	C6140-0030	C6140-0040	C6140-0050
Processor	Intel® Core™ Duo or Core™2 Duo	Intel® Celeron® up to Core™2 Duo	up to Core™ i3/i5/i7 2 nd generation
Motherboard	ATX	ATX	ATX
Slots	7	7	7
Free slots	3 PCI, 3 PCIe x1 and 1 PCIe x16 graphic card slot	3 PCI, 3 PCIe x1 and 1 PCIe x16 graphic card slot	3 PCI, 2 PCIe x1, 1 PCIe x4 and 1 PCIe x16
Max. card length	3 x 270 mm and 4 x 240 mm	3 x 270 mm and 4 x 240 mm	3 x 270 mm and 4 x 240 mm
Memory	1...3 GB DDR2RAM	1...8 GB DDR3 RAM	2...16 GB DDR3 RAM
Graphic adapter	on-board	on-board	integrated in the processor
Ethernet	on-board	on-board	on-board
Hard disks/flash	1-3 x 3½-inch HDD or 2½-inch SSD	1-3 x 3½-inch HDD or 2½-inch SSD	1-3 x 3½-inch HDD or 2½-inch SSD
RAID 1	2 x 3½-inch HDD	2 x 3½-inch HDD	2 x 3½-inch HDD
Possible disk drives	CD/DVD-ROM or multi-DVD	CD/DVD-ROM or multi-DVD	CD/DVD-ROM or multi-DVD
Power supply	100...240 V AC or 24 V DC	100...240 V AC or 24 V DC	100...240 V AC or 24 V DC
Recommendation	not recommended for new projects	available	recommended for new projects
Further information	for further options, technical drawings, documentations, etc. see www.beckhoff.com/C6140		



C6150 | Control cabinet Industrial PC

C6150	C6150-0030, -0040, -0050
Housing	7-slot ATX Industrial PC for control cabinet installation
	all slots for full-length plug-in cards
	drives and plug-in cards easily accessible
	all connectors on the top
	detailed PC configuration information on the front
	status LEDs and protected reset key
	card holders, actuated without tools
	protection class IP 20
	operating temperature 0...55 °C
	weight of the basic configuration 15 kg (33.1 lbs)
	dimensions (W x H x D) 381 x 423 x 265 mm (14.9" x 16.7" x 10.5")

Features	C6150-0030	C6150-0040	C6150-0050
Processor	Intel® Core™ Duo or Core™2 Duo	Intel® Celeron® up to Core™2 Duo	up to Core™ i3/i5/i7 2 nd generation
Motherboard	ATX	ATX	ATX
Slots	7	7	7
Free slots	3 PCI, 3 PCIe x1 and 1 PCIe x16 graphic card slot	3 PCI, 3 PCIe x1 and 1 PCIe x16 graphic card slot	3 PCI, 2 PCIe x1, 1 PCIe x4 and 1 PCIe x16
Max. card length	7 x fullsize	7 x fullsize	7 x fullsize
Memory	1...3 GB DDR2RAM	1...8 GB DDR3 RAM	2...16 GB DDR3 RAM
Graphic adapter	on-board	on-board	integrated in the processor
Ethernet	on-board	on-board	on-board
Hard disks/flash	1-3 x 3½-inch HDD or 2½-inch SSD	1-3 x 3½-inch HDD or 2½-inch SSD	1-3 x 3½-inch HDD or 2½-inch SSD
RAID 1	2 x 3½-inch HDD	2 x 3½-inch HDD	2 x 3½-inch HDD
Possible disk drives	CD/DVD-ROM or multi-DVD	CD/DVD-ROM or multi-DVD	CD/DVD-ROM or multi-DVD
Power supply	100...240 V AC or 24 V DC	100...240 V AC or 24 V DC	100...240 V AC or 24 V DC
Recommendation	not recommended for new projects	available	recommended for new projects
Further information	for further options, technical drawings, documentations, etc. see www.beckhoff.com/C6150		

C62xx | Industrial PC series for control cabinet installation

The control cabinet PC series C62xx comprises four devices of different size, all equipped with maximum performance class components: with Intel® Core™ Duo or Core™2 Duo on a slot motherboard or with Intel® Celeron®, Intel® Core™2 Duo or Core™ i3/i5/i7 of the 2nd generation on an ATX motherboard. The series provides the appropriate Industrial PC for every application, according to the available installation

space. All the PCs in the C62xx series are constructed according to a uniform plan, optimised for the exploitation of available space and easy accessibility of all components.

The construction of the housing for the C62xx series ensures long-term compatibility with any new PC components that appear over the next few years. If, in a few years, the Industrial PC needs to be upgraded,

you swap the motherboard, the processor, the memory or the hard disk, but the housing remains unchanged, and is compatible with the technology of the future.

All the PC's connections face to the front. The inner chassis can be drawn out forward on telescopic rails, thus offering free access to all the fitted components.

The C62xx series PCs are supplied with a 100...240 V AC full range or 24 V DC power





C6210

C6220

C6240

C6250

supply unit. An industrial latching socket strip is used for the power supply.

Card holders for the plug-in cards generate insensitivity to shocks and vibrations. The card holders can be fixed and removed without tools. Data describing the function and type for the fitted plug-in cards is listed on the front.



DVD drive slot

Power supply 100–240 V full range or 24 V DC, optionally with 24 V DC UPS

Passive side wall: fitting possible immediately next to other devices

6 free slots

Fan with speed monitoring and double ball bearing, easily exchangeable

1 serial interface RS232

Fan with speed monitoring and double ball bearing, easily exchangeable

Hard disk or SSD

ATX industrial motherboard

Inner chassis can be pulled forward

All connections on the front

On-board Ethernet adapter

4 USB 2.0 ports

► www.beckhoff.com/C62xx



C6210 | Control cabinet Industrial PC

C6210	C6210-0030
Housing	4-slot Industrial PC for space-saving control cabinet installation all slots for plug-in cards with a length of up to 190 mm drives and plug-in cards are easily accessible all connectors on the front detailed PC configuration information on the front status LEDs and protected reset key card holders, actuated without tools protection class IP 20 operating temperature 0...55 °C weight of the basic configuration 9.5 kg (21 lbs) dimensions (W x H x D) 257 x 170 x 286 mm (10.1" x 6.7" x 11.3")

Features	C6210-0030
Processor	Intel® Core™ Duo or Core™2 Duo
Motherboard	passive backplane
Slots	4
Free slots	1 PCI
Max. card length	4 x 190 mm
Memory	1...3 GB DDR2RAM
Graphic adapter	on-board
Ethernet	2 on-board
Hard disks/flash	1 x 2½-inch HDD or SSD
Possible disk drives	CD/DVD-ROM or multi-DVD
Power supply	100...240 V AC or 24 V DC
Recommendation	not recommended for new projects
Further information	for further options, technical drawings, documentations, etc. see www.beckhoff.com/C6210



C6220 | Control cabinet Industrial PC

C6220	C6220-0030
Housing	6-slot Industrial PC for space-saving control cabinet installation
	all slots for plug-in cards with a length of up to 190 mm
	drives and plug-in cards are easily accessible
	all connectors on the front
	detailed PC configuration information on the front
	status LEDs and protected reset key
	card holders, actuated without tools
	protection class IP 20
	operating temperature 0...55 °C
	weight of the basic configuration 10 kg (22 lbs)
	dimensions (W x H x D) 307 x 170 x 286 mm (12.1" x 6.7" x 11.3")

Features	C6220-0030
Processor	Intel® Core™ Duo or Core™2 Duo
Motherboard	passive backplane
Slots	6
Free slots	3 PCI
Max. card length	6 x 190 mm
Memory	1...3 GB DDR2RAM
Graphic adapter	on-board
Ethernet	2 on-board
Hard disks/flash	1 x 2½-inch HDD or SSD
Possible disk drives	CD/DVD-ROM or multi-DVD
Power supply	100...240 V AC or 24 V DC
Recommendation	not recommended for new projects
Further information	for further options, technical drawings, documentations, etc. see www.beckhoff.com/C6220



C6240 | Control cabinet Industrial PC

C6240	C6240-0030, -0040, -0050
Housing	7-slot ATX Industrial PC for control cabinet installation
	all slots for up to 190 mm long plug-in cards
	drives and plug-in cards easily accessible
	all connectors on the front
	detailed PC configuration information on the front
	status LEDs and protected reset key
	card holders, actuated without tools
	protection class IP 20
	operating temperature 0...55 °C
	weight of the basic configuration 12.3 kg (27.2 lbs)
	dimensions (W x H x D) 430 x 170 x 274 mm (16.9" x 6.7" x 10.8")

Features	C6240-0030	C6240-0040	C6240-0050
Processor	Intel® Core™ Duo or Core™2 Duo	Intel® Celeron® up to Core™2 Duo	up to Core™ i3/i5/i7 2 nd generation
Motherboard	ATX	ATX	ATX
Slots	7	7	7
Free slots	3 PCI, 3 PCIe x1 and 1 PCIe x16 graphic card slot	3 PCI, 3 PCIe x1 and 1 PCIe x16 graphic card slot	3 PCI, 2 PCIe x1, 1 PCIe x4 and 1 PCIe x16
Max. card length	7 x 190 mm	7 x 190 mm	7 x 190 mm
Memory	1...8 GB DDR3 RAM	1...8 GB DDR3 RAM	2...16 GB DDR3 RAM
Graphic adapter	on-board	on-board	integrated in the processor
Ethernet	on-board	on-board	on-board
Hard disks/flash	1 x 3½-inch HDD or 2 x 2½-inch HDD or SSD	1 x 3½-inch HDD or 2 x 2½-inch HDD or SSD	1 x 3½-inch HDD or 2 x 2½-inch HDD or SSD
RAID 1	2 x 2½-inch HDD	2 x 2½-inch HDD	2 x 2½-inch HDD
Possible disk drives	CD/DVD-ROM or multi-DVD	CD/DVD-ROM or multi-DVD	CD/DVD-ROM or multi-DVD
Power supply	100...240 V AC or 24 V DC	100...240 V AC or 24 V DC	100...240 V AC or 24 V DC
Recommendation	not recommended for new projects	available	recommended for new projects
Further information	for further options, technical drawings, documentations, etc. see www.beckhoff.com/C6240		



C6250 | Control cabinet Industrial PC

C6250	C6250-0040, -0050, -0060
Housing	7-slot ATX Industrial PC for control cabinet installation
	mounting sheet for horizontal installation
	all slots for up to 190 mm long plug-in cards
	drives and plug-in cards easily accessible
	all connectors on the front
	detailed PC configuration information on the front
	status LEDs and protected reset key
	card holders, actuated without tools
	protection class IP 20
	operating temperature 0...55 °C
	weight of the basic configuration 19.8 kg (43.7 lbs)
	dimensions (W x H x D) 680 x 184 x 270 mm (26.8" x 7.2" x 10.7")

Features	C6250-0040	C6250-0050	C6250-0060
Processor	Intel® Core™ Duo or Core™2 Duo	Intel® Celeron® up to Core™2 Duo	up to Core™ i3/i5/i7 2 nd generation
Motherboard	ATX	ATX	ATX
Slots	7	7	7
Free slots	3 PCI, 3 PCIe x1 and 1 PCIe x16 graphic card slot	3 PCI, 3 PCIe x1 and 1 PCIe x16 graphic card slot	3 PCI, 2 PCIe x1, 1 PCIe x4 and 1 PCIe x16
Max. card length	7 x 190 mm	7 x 190 mm	7 x 190 mm
Memory	1...3 GB DDR2RAM	1...8 GB DDR3 RAM	2...16 GB DDR3 RAM
Graphic adapter	on-board	on-board	integrated in the processor
Ethernet	on-board	on-board	on-board
Hard disks/flash	1-3 x 3½-inch HDD or 2½-inch SSD	1-3 x 3½-inch HDD or 2½-inch SSD	1-3 x 3½-inch HDD or 2½-inch SSD
RAID 1	2 x 3½-inch HDD	2 x 3½-inch HDD	2 x 3½-inch HDD
Possible disk drives	CD/DVD-ROM or multi-DVD	CD/DVD-ROM or multi-DVD	CD/DVD-ROM or multi-DVD
Power supply	100...240 V AC or 24 V DC	100...240 V AC or 24 V DC	100...240 V AC or 24 V DC
Recommendation	not recommended for new projects	available	recommended for new projects
Further information	for further options, technical drawings, documentations, etc. see www.beckhoff.com/C6250		

C63xx | Industrial PC series for control cabinet installation

The C63xx series of Industrial PCs has been designed for control cabinet installation. The compact housing is equipped with a slot motherboard for Intel® Core™ Duo or Core™2 Duo. One or three free PCI slots are available. A graphics adapter and two Ethernet adapters are available on-board

without occupying a slot. The use of a field-bus interface card transforms the C6320 into a very compact, high performance machine control. C6330, C6335 and C6350 offer an additional CD/DVD-ROM or multi DVD drive, although they are only 14 mm wider than the C6320, C6325 and C6340.

All PC connections are on one side of the housing. The PC can optionally be equipped with mounting plates on two sides and fastened with screws in the control cabinet. In terms of the photograph, installation is possible at the rear panel or on the right-hand panel. For maintenance purposes,





C6320

C6325

C6330

C6335

C6340

C6350

the internal chassis can be removed from the external housing. Once removed, the internal chassis is still fully operational as a PC and can be operated with a standard USB keyboard and a standard DVI display. The PCs of this series are supplied with a 24 V DC power supply unit.

The DVI and USB interfaces supplied with the basic configuration enable the connection of a Control Panel. The Industrial PCs of this series and a Beckhoff Control Panel as its operating unit create an ideal combination.

The C6325 and C6335 enable fanless operation up to 45 °C. Because Compact

Flash or a solid-state disk (SSD) is used instead of a conventional hard disk, the C6325 is a PC without moving parts.



Fan with speed monitoring and double ball bearing, easily exchangeable

DVI-I connection

1 serial interface RS232

Slot motherboard

Hard disk or SSD

On-board dual Ethernet adapter

USB 2.0 ports

PCI slots

DVD drive

24 V DC power supply, optionally with UPS

► www.beckhoff.com/C63xx



C6320



C6330

C6320, C6330 | Control cabinet Industrial PC

C6320, C6330	C6320-0040	C6330-0040
Housing	3-slot Industrial PC for space-saving control cabinet installation	3-slot Industrial PC for space-saving control cabinet installation
	mounting sheet at the rear wall	mounting sheet at the rear wall
	1 slot for plug-in cards with a length of up to 190 mm	1 slot for plug-in cards with a length of up to 190 mm
	drives and plug-in cards easily accessible	drives and plug-in cards easily accessible
	all connectors at one side	all connectors at one side
	detailed PC configuration information on the housing	detailed PC configuration information on the housing
	protection class IP 20	protection class IP 20
	operating temperature 0...55 °C	operating temperature 0...55 °C
	weight of the basic configuration 4 kg (8.8 lbs)	weight of the basic configuration 4.6 kg (10.1 lbs)
	compact dimensions (W x H x D) 93 x 196 x 226 mm (3.6" x 7.7" x 8.8") without mounting plate	compact dimensions (W x H x D) 107 x 196 x 226 mm (4.2" x 7.7" x 8.8") without mounting plate

Features	C6320-0040	C6330-0040
Processor	Intel® Core™ Duo or Core™2 Duo	Intel® Core™ Duo or Core™2 Duo
Motherboard	passive backplane	passive backplane
Slots	3	3
Free slots	1 PCI	1 PCI
Max. card length	1 x 190 mm	1 x 190 mm
Memory	1...3 GB DDR2RAM	1...3 GB DDR2RAM
Graphic adapter	on-board	on-board
Ethernet	2 on-board	2 on-board
Hard disks/flash	1 x 2½-inch HDD or SSD or CF card	1 x 2½-inch HDD or SSD or CF card
Possible disk drives	–	CD/DVD-ROM or multi-DVD
Power supply	24 V DC	24 V DC
Recommendation	not recommended for new projects	not recommended for new projects
Further information	for further options, technical drawings, documentations, etc. see www.beckhoff.com/C6320	



C6325



C6335

C6325, C6335 | Fanless control cabinet Industrial PC

C6325, C6335	C6325-0040	C6335-0040
Housing	fanless 3-slot Industrial PC for space-saving control cabinet installation	fanless 3-slot Industrial PC for space-saving control cabinet installation
	mounting sheet at the rear wall	mounting sheet at the rear wall
	1 slot for plug-in cards with a length of up to 190 mm	1 slot for plug-in cards with a length of up to 190 mm
	drives and plug-in cards easily accessible	drives and plug-in cards easily accessible
	all connectors on one side	all connectors on one side
	detailed PC configuration information on the housing	detailed PC configuration information on the housing
	passive cooling without fan through heat sink structure at the outer housing	passive cooling without fan through heat sink structure at the outer housing
	10 cm (4") free space on top and bottom of the PC necessary for air circulation	10 cm (4") free space on top and bottom of the PC necessary for air circulation
	protection class IP 20	protection class IP 20
	operating temperature 0...45 °C	operating temperature 0...45 °C
	weight of the basic configuration 6 kg (13.2 lbs)	weight of the basic configuration 6.6 kg (14.6 lbs)
	compact dimensions (W x H x D) 133 x 196 x 226 mm (5.2" x 7.7" x 8.8") without mounting plate	compact dimensions (W x H x D) 147 x 196 x 226 mm (5.8" x 7.7" x 8.8") without mounting plate

Features	C6325-0040	C6335-0040
Processor	Intel® Core™ Duo or Core™2 Duo	Intel® Core™ Duo or Core™2 Duo
Motherboard	passive backplane	passive backplane
Slots	3	3
Free slots	1 PCI	1 PCI
Max. card length	1 x 190 mm	1 x 190 mm
Memory	1...3 GB DDR2RAM	1...3 GB DDR2RAM
Graphic adapter	on-board	on-board
Ethernet	2 on-board	2 on-board
Hard disks/flash	1 x 2½-inch HDD or SSD or CF card	1 x 2½-inch HDD or SSD or CF card
Possible disk drives	–	CD/DVD-ROM or multi-DVD
Power supply	24 V DC	24 V DC
Recommendation	not recommended for new projects	not recommended for new projects
Further information	for further options, technical drawings, documentations, etc. see www.beckhoff.com/C6325	



C6340 | Control cabinet Industrial PC

C6340	C6340-0040
Housing	5-slot Industrial PC for space-saving control cabinet installation
	mounting sheet at the rear wall
	3 slots for plug-in cards with a length of up to 190 mm
	drives and plug-in cards easily accessible
	all connectors on one side
	detailed PC configuration information on the housing
	protection class IP 20
	operating temperature 0...55 °C
	weight of the basic configuration 4.5 kg (9.9 lbs)
	compact dimensions (W x H x D) 134 x 196 x 226 mm (5.3" x 7.7" x 8.8") without mounting plate

Features	C6340-0040
Processor	Intel® Core™ Duo or Core™2 Duo
Motherboard	passive backplane
Slots	5
Free slots	3 PCI
Max. card length	3 x 190 mm
Memory	1...3 GB DDR2RAM
Graphic adapter	on-board
Ethernet	2 on-board
Hard disks/flash	1 x 2½-inch HDD or SSD or CF card
Power supply	24 V DC
Recommendation	not recommended for new projects
Further information	for further options, technical drawings, documentations, etc. see www.beckhoff.com/C6340



C6350 | Control cabinet Industrial PC

C6350	C6350-0040
Housing	5-slot Industrial PC for space-saving control cabinet installation
	mounting sheet at the rear wall
	3 slots for plug-in cards with a length of up to 190 mm
	drives and plug-in cards easily accessible
	all connectors on one side
	detailed PC configuration information on the housing
	protection class IP 20
	operating temperature 0...55 °C
	weight of the basic configuration 5.1 kg (11.2 lbs)
	compact dimensions (W x H x D) 148 x 196 x 226 mm (5.8" x 7.7" x 8.8") without mounting plate

Features	C6350-0040
Processor	Intel® Core™ Duo or Core™2 Duo
Motherboard	passive backplane
Slots	5
Free slots	3 PCI
Max. card length	3 x 190 mm
Memory	1...3 GB DDR2RAM
Graphic adapter	on-board
Ethernet	2 on-board
Hard disks/flash	1 x 2½-inch HDD or SSD or CF card
Possible disk drives	CD/DVD-ROM or multi-DVD
Power supply	24 V DC
Recommendation	not recommended for new projects
Further information	for further options, technical drawings, documentations, etc. see www.beckhoff.com/C6350

C65xx | Industrial PC series for control cabinet installation

The C65xx Industrial PC series is designed to be installed in control cabinet walls or in the rear panel of a control housing or console housing. The heat sink of the IPC is thereby fed to the outside through a suitable cut-out in the panel or wall of the control cabinet. Power dissipation from the processor and chipset takes place directly to ambient. Integrated seals provide for an

IP 67 closure. This enables high thermal stability and at the same time fanless operation. Industrial PCs of type C65xx can thus be constructed completely without rotating parts. Installation in a control housing in combination with a Beckhoff Control Panel results in a fanless Panel PC that can be operated at ambient temperatures up to 45 °C.

The compact housing is equipped with a Beckhoff 3½-inch motherboard for Intel® Celeron®, Intel® Core™2 Duo or Core™ i3/ i5/i7 of the 2nd generation. All of the PC's connectors are located on the top side of the housing. The C65xx series PCs are supplied with an integrated power supply unit with 24 V DC input voltage, optionally with integrated uninterruptible power supply (UPS).

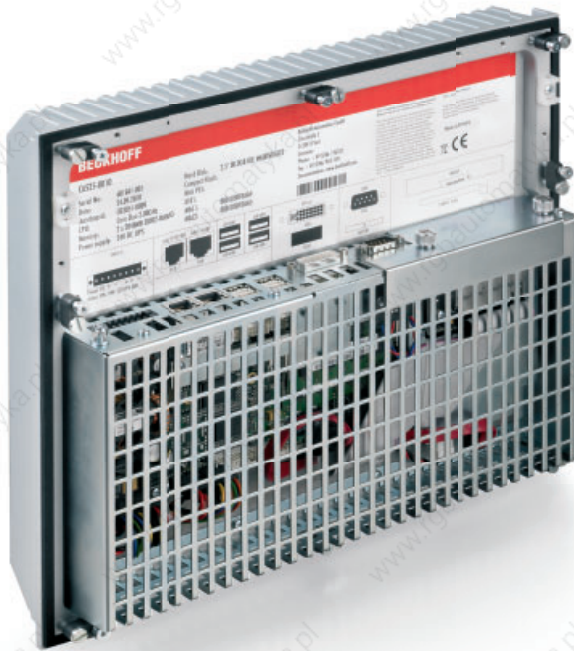



C6515
basic configuration



C6515
with PCIe module slots



C6525
basic configuration



C6525
with PCIe module slots



C6525
with plug-in card slots

A battery pack can be connected externally and installed on a DIN rail close to the PC. The PC has a free Mini PCI slot that can be used for NOVRAM modules for fail-safe storage of process data. The C6525 also enables the use of Mini PCI fieldbus cards or a further Ethernet card.

Industrial PCs from this series and Beckhoff Control Panels as control units

make an ideal combination for high-performance control platforms in machine construction and plant engineering applications, particularly in conjunction with TwinCAT automation software under Windows CE, Windows XP, Windows 7 or Windows Embedded Standard. Due to their two independent Ethernet interfaces the C6515 and C6525 Industrial PCs are ideally suited as

compact central processing units for an EtherCAT control system.

The C6525 enables the installation of two hard disks, which can be mirrored using the on-board SATA RAID 1 controller with Intel® matrix storage technology. If one of the hard disks fails, the system continues to run. The faulty hard disk can be replaced and mirrored during operation.

DVI connection

24 V DC power supply,
optionally with UPS

On-board dual
Ethernet adapter

4 USB 2.0 ports

1 Mini PCI slot for
fieldbus cards

3½-inch motherboard

Lithium battery easily accessible

1 serial interface RS232

For C6525 hard disks or SSDs

CF or CFast flash card

For C6525 optionally 2 PCI or
PCIe plug-in card slots

or 2 PCIe module slots



► www.beckhoff.com/C65xx



C6515 | Fanless built-in Industrial PC

C6515	C6515-0010, -0020, -0030, -0040
Housing	built-in Industrial PC with external cooling to be mounted in the back panel of a control housing or in the wall of a control cabinet
	2 slots for flash cards
	flash cards and lithium battery of the system clock easily exchangeable
	passive cooling through heat sink structure outside
	20 cm free space required around the heat sink of the PC for air circulation
	protection class outside IP 67, inside IP 20
	operating temperature outside 0...45 °C, inside 0...55 °C
	dimensions (W x H x D) 240 x 230 x 81 mm (9.5" x 9.1" x 3.2")

Features	C6515-0010	C6515-0020	C6515-0030	C6515-0040
Processor	Intel® Core™ Duo or Core™2 Duo	Intel® Core™2 Duo	Intel® Celeron® up to Core™2 Duo	up to Core™ i3/i5/i7 2 nd generation
Motherboard	3½-inch	3½-inch	3½-inch	3½-inch
Slots	1 Mini PCI slot	1 Mini PCI, optionally 2 PCIe modules	1 Mini PCI, optionally 2 PCIe modules	1 Mini PCI, optionally 2 PCIe modules
Free slots	1 Mini PCI for NOVRAM	1 Mini PCI for NOVRAM and optionally 2 PCIe modules	1 Mini PCI for NOVRAM and optionally 2 PCIe modules	1 Mini PCI for NOVRAM and optionally 2 PCIe modules
Max. card length	Mini PCI	Mini PCI, optionally 2 PCIe modules	Mini PCI, optionally 2 PCIe modules	Mini PCI, optionally 2 PCIe modules
Memory	1...3 GB DDR2RAM	1...8 GB DDR3 RAM	1...8 GB DDR3 RAM	2...16 GB DDR3 RAM
Graphic adapter	on-board	on-board	on-board	integrated in the processor
Ethernet	2 on-board	2 on-board	2 on-board	2 on-board
Hard disks/flash	1 or 2 x CF card	1 or 2 x CF card	1 or 2 x CFast	1 or 2 x CFast
RAID 1	–	–	2 x CFast	2 x CFast
Power supply	24 V DC	24 V DC	24 V DC	24 V DC
Recommendation	not recommended for new projects	available	recommended for new projects	recommended for new projects
Further information	for further options, technical drawings, documentations, etc. see www.beckhoff.com/C6515			



C6515-0020/-0030/-0040 with PCIe module slots



C6515-0020, -0030 and -0040 | Extension for PCIe modules

The built-in PCs C6515-0020, -0030 and -0040 can be expanded by two additional PCIe module slots. The inner enclosure cover is constructed 26 mm deeper for PCIe modules (see above). The module slots can accept Beckhoff PCIe modules, for example, the FC9062 dual gigabit Ethernet module, or they can serve to lead out motherboard interfaces, such as COM ports, USB or sound. The module slots also enable the use of field-

bus cards in the Mini PCI slot. Module slots that are not occupied by a PCIe module can be used to lead out the fieldbus connection of a Mini PCI card from the PC. An Ethernet or fieldbus interface for PROFIBUS, CANopen, DeviceNet or SERCOS can be inserted into the Mini PCI slot on the C6515, even though the basic configuration of this PC only allows NOVRAM Mini PCI cards.



PCIe module FC9062, dual gigabit Ethernet

Ordering information	Options for C6515-0020, -0030, -0040
C9900-B502	2 PCIe module slots integrated inside C6515, to plug-in Beckhoff PCIe modules or to lead out interfaces of the motherboard ex factory. The depth of the inner enclosure cover is increased by 26 mm (1").

Ordering information	Options for C6515 with 2 module slots C9900-B502
FC9062	gigabit Ethernet PCIe module for PCs with Beckhoff PCIe module slots, 2-channel, PCI Express x1 bus
C9900-E159	serial port COM2, RS232, optically linked, overload protection, D-sub 9-pin connector
C9900-E188	serial port COM2, RS485, optically linked, overload protection, D-sub 9-pin connector
C9900-E189	serial port COM2, RS422, optically linked, overload protection, D-sub 9-pin connector
C9900-E232	sound line input and sound line output of the motherboard led out at the connection section of a C6515
C9900-E233	1 serial port RS232 of the motherboard led out at the connection section of a C6515
C9900-E234	2 USB ports of the motherboard led out at the connection section of a C6515
C9900-E237	additional DVI-D plug led out on a modul bracket



C6525 | Fanless built-in Industrial PC

C6525	C6525-0010, -0020, -0030, -0040
Housing	built-in Industrial PC with external cooling to be mounted in the back panel of a control housing or in the wall of a control cabinet
	1 slot for 2½-inch hard disk or SSD and 1 slot for a flash card
	hard disk, SSD, flash card and lithium battery of the system clock easily exchangeable
	passive cooling through heat sink structure outside
	20 cm free space required around the heat sink of the PC for air circulation
	protection class outside IP 67, inside IP 20
	operating temperature outside 0...45 °C, inside 0...55 °C
	dimensions (W x H x D) 330 x 275 x 82 mm (13" x 10.8" x 3.2")



Features	C6525-0010	C6525-0020	C6525-0030	C6525-0040
Processor	Intel® Core™ Duo or Core™2 Duo	Intel® Core™2 Duo	Intel® Celeron® up to Core™2 Duo	up to Core™ i3/i5/i7 2 nd generation
Motherboard	3½-inch	3½-inch	3½-inch	3½-inch
Slots	1 Mini PCI slot	1 Mini PCI, optionally 2 PCIe modules or 2 plug-in card slots	1 Mini PCI, optionally 2 PCIe modules or 2 plug-in card slots	1 Mini PCI, optionally 2 PCIe modules or 2 plug-in card slots
Free slots	1 Mini PCI slot	1 Mini PCI and optionally 2 PCIe modules or 2 PCI/PCIe plug-in card slots	1 Mini PCI and optionally 2 PCIe modules or 2 PCI/PCIe plug-in card slots	1 Mini PCI and optionally 2 PCIe modules or 2 PCI/PCIe plug-in card slots
Max. card length	Mini PCI	Mini PCI, optionally 2 PCIe modules or 2 x 190 mm plug-in cards	Mini PCI, optionally 2 PCIe modules or 2 x 190 mm plug-in cards	Mini PCI, optionally 2 PCIe modules or 2 x 190 mm plug-in cards
Memory	1...3 GB DDR2RAM	1...8 GB DDR3 RAM	1...8 GB DDR3 RAM	2...16 GB DDR3 RAM
Graphic adapter	on-board	on-board	on-board	integrated in the processor
Ethernet	2 on-board	2 on-board	2 on-board	2 on-board
Hard disks/flash	2½-inch HDD or SDD and/or CF card or 2 x CF card or 2 x 2½-inch HDD or SDD	2½-inch HDD or SDD and/or CF card or 2 x CF card or 2 x 2½-inch HDD or SDD	2½-inch HDD or SDD and/or CFast or 2 x CFast or 2 x 2½-inch HDD or SDD	2½-inch HDD or SDD and/or CFast or 2 x CFast or 2 x 2½-inch HDD or SDD
RAID 1	2 x 2½-inch HDD	2 x 2½-inch HDD	2 x 2½-inch HDD or 2 x CFast	2 x 2½-inch HDD or 2 x CFast
Power supply	24 V DC	24 V DC	24 V DC	24 V DC
Recommendation	not recommended for new projects	available	recommended for new projects	recommended for new projects
Further information	for further options, technical drawings, documentations, etc. see www.beckhoff.com/C6525			



C6525-0020/-0030/-0040
with PCIe module slots

C6525-0020, -0030 and -0040 | Extension for PCIe modules

The built-in PCs C6525-0020, -0030 and -0040 can be expanded by two additional PCIe module slots. The inner enclosure cover is constructed 27 mm deeper for PCIe modules (see above). The module slots can accept Beckhoff PCIe modules, for example, the

FC9062 dual gigabit Ethernet module, or they can serve to lead out motherboard interfaces, such as COM ports, USB or sound.



PCIe module FC9062, dual gigabit Ethernet

Ordering information	Options for C6525-0020, -0030, -0040
C9900-B503	2 PCIe module slots integrated inside C6525, to plug-in Beckhoff PCIe modules or to lead out interfaces of the motherboard ex factory. The depth of the inner enclosure cover is increased by 27 mm (1.1").

Ordering information	Options for C6525 with 2 module slots C9900-B503
FC9062	gigabit Ethernet PCIe module for PCs with Beckhoff PCIe module slots, 2-channel, PCI Express x1 bus
C9900-E232	sound line input and sound line output of the motherboard led out at the connection section of a C6525
C9900-E233	1 serial port RS232 of the motherboard led out at the connection section of a C6525
C9900-E234	2 USB ports of the motherboard led out at the connection section of a C6525
C9900-E237	additional DVI-D plug led out on a modul bracket



C6525-0020/-0030/-0040
with plug-in card slots

C6525-0020, -0030 and -0040 | Extension for PCI and PCIe plug-in cards

The built-in PCs C6525-0020, -0030 and -0040 can be expanded by two slots for standard PC plug-in cards. They can accept conventional PC plug-in cards up to 190 mm in length. The 58 mm deeper hood at the rear (see above) covers a backplane that provides

a choice of two PCI slots, two PCI Express slots or one PCI and one PCI Express slot. Card holders ensure the secure fixation of large cards.

Ordering information	Options for C6525-0020, -0030, -0040
C9900-B505	2 PCIe plug-in card slots on the passive backplane integrated inside C6525, to plug-in PCIe x1 cards up to 190 mm (6.3") length. The depth of the inner enclosure cover is increased by 58 mm (2.3").
C9900-B509	2 PCI plug-in card slots on the passive backplane integrated inside C6525, to plug-in PCI cards up to 190 mm (6.3") length, the depth of the inner enclosure cover is increased by 58 mm (2.3").
C9900-B513	1 PCI and 1 PCIe plug-in card slot on a passive backplane integrated inside C6525, to plug-in one PCI and one PCIe x1 card up to 190 mm (6.3") length. The depth of the back cover is increased by 58 mm (2.3").

C66xx | Industrial PC series for control cabinet installation

The C66xx control cabinet PC series includes two devices, both of which are equipped with top-performance components with Intel® Celeron®, Intel® Core™2 Duo or Core™ i3/ i5/i7 of the 2nd generation on an ATX motherboard. Three free PCI and three PCI Express x1 slots are available for plug-in cards with a length of up to 210 mm. Graphics and

10/100 Mbit Ethernet adapters are already available on-board, without taking up a slot.

All PC connections face upwards, so that the connecting cable can be taken directly to the wiring channel. The side walls are completely passive, and allow the Industrial PC to be fitted immediately next to other control cabinet devices.

The C66xx series is designed for optimum space utilisation and easy accessibility of all components. The C6640 is the most compact PC with ATX motherboard but nevertheless offers convenient access to drives, memory and plug-in cards.

The C6650 features hard drive removable frames which, together with the on-board





C6640

RAID controller, form a RAID 1 system with two mirrored hard disks. This ensures high data security. Hard disks which failed can easily be exchanged during operation.

The housing design of the C66xx series ensures long-term compatibility with new PC components. The motherboard, processor, memory or hard disk are upgradable, while



C6650

the same housing can be used for years to come.

The device can be equipped with a CD/DVD ROM or multi DVD drive. A choice of a Compact Flash socket or a 2½-inch SSD slot is offered for flash disks. Card holders for the plug-in cards generate insensitivity to impacts and vibrations. The C66xx series

PCs are supplied with 100 to 240 V AC full range or 24 V DC power supply unit.

A type plate is located on the front cover, giving detailed information about the PC configuration.

The housing design offers plenty of scope for adjustment to the respective application.

On-board Ethernet adapter

4 USB 2.0 ports

All connections on the top

ATX motherboard

6 free slots

Fan with speed monitoring and double ball bearing, easily exchangeable

1 serial interface RS232

Power supply 100–240 V full range or 24 V DC, optionally with 24 V DC UPS

Passive side wall: fitting possible immediately next to other devices

Optional SSD, CF or CFAST flash card

DVD drive slot

Hard disks in removable frames



► www.beckhoff.com/C66xx



C6640 | Control cabinet Industrial PC

C6640	C6640-0010, -0020, -0030
Housing	7-slot ATX Industrial PC for control cabinet installation all slots for up to 210 mm long plug-in cards drives and plug-in cards easily accessible 3 brackets to led out serial interfaces all connectors on the top detailed PC configuration information on the front card holders, actuated without tools protection class IP 20 operating temperature 0...55 °C weight of the basic configuration 11 kg (24.3 lbs) dimensions (W x H x D) 371 x 336 x 198 mm (14.6" x 13.2" x 7.8")

Features	C6640-0010	C6640-0020	C6640-0030
Processor	Intel® Core™ Duo or Core™2 Duo	Intel® Celeron® up to Core™2 Duo	up to Core™ i3/i5/i7 2 nd generation
Motherboard	ATX	ATX	ATX
Slots	7	7	7
Free slots	3 PCI, 3 PCIe x1 and 1 PCIe x16 graphic card slot	3 PCI, 3 PCIe x1 and 1 PCIe x16 graphic card slot	3 PCI, 2 PCIe x1, 1 PCIe x4 and 1 PCIe x16
Max. card length	6 x 210 mm	6 x 210 mm	7 x 210 mm
Memory	1...3 GB DDR2RAM	1...8 GB DDR3 RAM	2...16 GB DDR3 RAM
Graphic adapter	on-board	on-board	integrated in the processor
Ethernet	on-board	on-board	on-board
Hard disks/flash	1 x 3½-inch and 1 x 2½-inch HDD or SSD or CF card	1 x 3½-inch and 1 x 2½-inch HDD or SSD or CF card	1 x 3½-inch and 1 x 2½-inch HDD or SSD or CFast
RAID 1	–	–	–
Possible disk drives	CD/DVD-ROM or multi-DVD	CD/DVD-ROM or multi-DVD	CD/DVD-ROM or multi-DVD
Power supply	100...240 V AC or 24 V DC	100...240 V AC or 24 V DC	100...240 V AC or 24 V DC
Recommendation	not recommended for new projects	available	recommended for new projects
Further information	for further options, technical drawings, documentations, etc. see www.beckhoff.com/C6640		



C6650 | Control cabinet Industrial PC

C6650	C6650-0010, -0020, -0030
Housing	7-slot ATX Industrial PC for control cabinet installation
	all slots for up to 210 mm long plug-in cards
	2 removable frames for hard disks
	drives and plug-in cards easily accessible
	3 brackets to lead out serial interfaces
	all connectors on the top
	detailed PC configuration information on the front
	card holders, actuated without tools
	protection class IP 20
	operating temperature 0...55 °C
	weight of the basic configuration 12 kg (26.5 lbs)
	dimensions (W x H x D) 410 x 360 x 201 mm (16.1" x 14.2" x 7.9")

Features	C6650-0010	C6650-0020	C6650-0030
Processor	Intel® Core™ Duo or Core™2 Duo	Intel® Celeron® up to Core™2 Duo	up to Core™ i3/i5/i7 2 nd generation
Motherboard	ATX	ATX	ATX
Slots	7	7	7
Free slots	3 PCI, 3 PCIe x1 and 1 PCIe x16 graphic card slot	3 PCI, 3 PCIe x1 and 1 PCIe x16 graphic card slot	3 PCI, 2 PCIe x1, 1 PCIe x4 and 1 PCIe x16
Max. card length	6 x 210 mm	6 x 210 mm	7 x 210 mm
Memory	1...3 GB DDR2RAM	1...8 GB DDR3 RAM	2...16 GB DDR3 RAM
Graphic adapter	on-board	on-board	integrated in the processor
Ethernet	on-board	on-board	on-board
Hard disks/flash	1–2 x 3½-inch and 1 x 2½-inch HDD or SSD or CF card	1–2 x 3½-inch and 1 x 2½-inch HDD or SSD or CF card	1–2 x 3½-inch and 1 x 2½-inch HDD or SSD or CFast
RAID 1	2 x 3½-inch HDD	2 x 3½-inch HDD	2 x 3½-inch HDD
Possible disk drives	CD/DVD-ROM or multi-DVD	CD/DVD-ROM or multi-DVD	CD/DVD-ROM or multi-DVD
Power supply	100...240 V AC or 24 V DC	100...240 V AC or 24 V DC	100...240 V AC or 24 V DC
Recommendation	not recommended for new projects	available	recommended for new projects
Further information	for further options, technical drawings, documentations, etc. see www.beckhoff.com/C6650		

C69xx | Industrial PC series for control cabinet installation

The C69xx Industrial PC series is designed for installation in control cabinets. The compact aluminium housing of the C69xx Industrial PCs is equipped with a 3½-inch motherboard. All PC connections are on one side of the housing. The PC can optionally be equipped with mounting plates on two sides and fastened with screws in the control cabinet. Installation is possible at the rear panel or on the right-hand side panel (see figure).

The C69xx series PCs are supplied with a 24 V DC power supply unit, optionally with integrated uninterruptible power supply (UPS). A battery pack can be connected externally and installed on a DIN rail close to the PC. Cooling fins behind the right-hand side panel enable fanless operation of the PC at temperatures up to 55 °C. The four types of Industrial PCs in the C69xx series differ in their processors and data storage devices.

Cooling of the C6915 with Intel® Atom™ 1.1 or 1.6 GHz and the C6925 with Intel® Celeron® ULV 1.2 GHz requires no fan. The basic configuration of the C6915 and C6925 features a flash disk, thereby creating PCs without moving parts. A hard disk or a second flash CF card can be integrated in all of the PCs from this series as an option.

The C6920 with Intel® Celeron®, Intel® Core™2 Duo or Core™ i3/i5/i7 of the 2nd





C6915

C6920

basic configuration

C6920

with plug-in card slots

C6925

C6930

basic configuration

C6930

with plug-in card slots

generation has an easily exchangeable fan cartridge on the underside of the housing. The C6930 Industrial PC is also offered with Intel® Celeron®, Intel® Core™2 Duo or Core™ i3/i5/i7 of the 2nd generation. It has a SATA RAID controller for mirroring two hard disks, SSDs or CFast cards. In the basic configuration, one of the two hard disk slots is equipped with a 80 GB drive. A second hard disk is offered as an option. In addition,

a Compact Flash or CFast slot is accessible behind the front cover.

All of the CP69xx PCs feature a free Mini PCI slot. The Beckhoff Mini PCI fieldbus cards for PROFIBUS (FC3151), CANopen (FC5151), DeviceNet (FC5251), SERCOS (FC7551), or a further Ethernet card (FC9151) can be used.

Industrial PCs of this series and a Beckhoff Control Panel with DVI and USB connection or an Ethernet Control Panel

as operating unit make an ideal combination and offer a high-performance control platform for machine construction and plant engineering applications, particularly in conjunction with the TwinCAT automation software under Windows Embedded Standard or Windows XP Professional. Due to its two independent Ethernet interfaces, the C69xx is ideally suited as a compact central processing unit for an EtherCAT control system.

Lithium battery easily accessible

CF or CFast flash card

2nd RS232 serial interface with output via PCIe module slot

4 USB 2.0 ports

Hard disk or SSD

1 serial interface RS232

24 V DC power supply, optionally with UPS

C6930: 2 PCIe module slots

On-board dual Ethernet adapter

Optionally 2 PCI or PCIe plug-in card slots

3½-inch motherboard

DVI-I connection

1 Mini PCI slot for fieldbus cards



► www.beckhoff.com/C69xx



C6915 | Control cabinet Industrial PC with Intel® Atom™

C6915	C6915-0000
Housing	fanless industrial PC for space-saving control cabinet installation
	mounting sheet at the rear wall
	all connectors on the front
	status LEDs
	lithium battery accessible behind the front flap
	1 slot for one Compact Flash card behind the front flap
	passive cooling without fan
	5 cm (2") free space on top and bottom of the PC necessary for air circulation
	protection class IP 20
	operating temperature 0...55 °C
weight of the basic configuration 1.25 kg (2.8 lbs)	
compact dimensions (W x H x D) 48 x 164 x 119 mm (1.9" x 6.5" x 4.7") without mounting plate	

Features	C6915-0000
Processor	Intel® Atom™
Motherboard	3½-inch
Slots	1 Mini PCI slot
Free slots	1 Mini PCI slot
Max. card length	Mini PCI
Memory	1...2 GB DDR2RAM
Graphic adapter	on-board
Ethernet	2 on-board
Hard disks/flash	2½-inch HDD or SSD or 1 CF card or 2 CF cards
Power supply	24 V DC
Recommendation	available
Further information	for further options, technical drawings, documentations, etc. see www.beckhoff.com/C6915



C6920 | Control cabinet Industrial PC

C6920	C6920-0010, -0020, -0030, -0040
Housing	industrial PC for space-saving control cabinet installation
	mounting sheet at the rear wall
	all connectors on the front, status LEDs
	lithium battery accessible behind the front flap
	1 slot for one 2½-inch hard disk or SSD behind the front flap
	1 slot for one flash card behind the front flap
	fan cartridge with speed control and double ball bearing fans, accessible from the front
	5 cm (2") free space above and under the PC required for air circulation
	protection class IP 20
	operating temperature 0...55 °C
weight of the basic configuration 1.9 kg (4.2 lbs)	
compact dimensions (W x H x D) 65 x 231 x 119 mm (2.6" x 9.1" x 4.7") without mounting plate	

Features	C6920-0010	C6920-0020	C6920-0030	C6920-0040
Processor	Intel® Core™ Duo or Core™2 Duo	Intel® Core™2 Duo	Intel® Celeron® up to Core™2 Duo	up to Core™ i3/i5/i7 2 nd generation
Motherboard	3½-inch	3½-inch	3½-inch	3½-inch
Slots	1 Mini PCI slot	1 Mini PCI, optionally 2 plug-in card slots	1 Mini PCI, optionally 2 plug-in card slots	1 Mini PCI, optionally 2 plug-in card slots
Free slots	1 Mini PCI slot	1 Mini PCI and optionally 2 PCI/PCIe plug-in card slots	1 Mini PCI and optionally 2 PCI/PCIe plug-in card slots	1 Mini PCI and optionally 2 PCI/PCIe plug-in card slots
Max. card length	Mini PCI	Mini PCI, optionally 2 x 190 mm plug-in cards	Mini PCI, optionally 2 x 190 mm plug-in cards	Mini PCI, optionally 2 x 190 mm plug-in cards
Memory	1...3 GB DDR2RAM	1...8 GB DDR3 RAM	1...8 GB DDR3 RAM	2...16 GB DDR3 RAM
Graphic adapter	on-board	on-board	on-board	integrated in the processor
Ethernet	2 on-board	2 on-board	2 on-board	2 on-board
Hard disks/flash	2½-inch HDD or SDD and/or CF card or 2 CF cards	2½-inch HDD or SDD and/or CF card or 2 CF cards	2½-inch HDD or SDD and/or 1 x CFast or 2 x CFast	2½-inch HDD or SDD and/or 1 x CFast or 2 x CFast
RAID 1	–	–	2 x CFast	2 x CFast
Power supply	24 V DC	24 V DC	24 V DC	24 V DC
Recommendation	not recommended for new projects	available	recommended for new projects	recommended for new projects
Further information	for further options, technical drawings, documentations, etc. see www.beckhoff.com/C6920			



C6920-0020/-0030/-0040 with plug-in card slots



C6920-0020, -0030 and -0040 | Extension for PCI and PCIe plug-in cards

The control cabinet PCs C6920-0020, -0030 and -0040 can be expanded by two slots for standard PC plug-in cards. They can accept conventional PC plug-in cards up to 190 mm in length. The 70 mm wider PC (see above) housing includes a backplane that provides a choice of two PCI slots, two PCI Express slots or one PCI and one PCI Express slot. The plug-in card connectors are located on

the top side of the PC. The plug-in card slots are arranged on the right side of the PC. An aluminium cover on the front of the slot expansion enables easy installation of the plug-in cards without having to open the housing of the computer core. The slots are powered internally by the PC power supply.

Ordering information	Options for C6920-0020, -0030, -0040
C9900-B506	2 PCIe plug-in card slots on the passive backplane integrated inside C6920, to plug-in PCIe x1 cards up to 190 mm (6.3") length. The connectors of the plug-in cards are located at the top side of the PC on the right. The width of the PC housing is increased by 70 mm (2.76"), the depth is increased by 18 mm (0.7").
C9900-B510	2 PCI plug-in card slots on the passive backplane integrated inside C6920, to plug-in PCI cards up to 190 mm (6.3") length. The connectors of the plug-in cards are located at the top side of the PC on the right. The width of the PC housing is increased by 70 mm (2.76"), the depth is increased by 18 mm (0.7").
C9900-B514	1 PCI and 1 PCIe plug-in card slot on a passive backplane integrated inside C6920, to plug-in one PCI and one PCIe x1 card up to 190 mm (6.3") length. The connectors of the plug-in cards are located at the top side of the PC on the right. The width of the PC enclosure is increased by 70 mm (2.76"), the depth is increased by 18 mm (0.7").



C6925 | Fanless control cabinet Industrial PC

C6925	C6925-0010
Housing	fanless industrial PC for space-saving control cabinet installation mounting sheet at the rear wall all connectors on the front status LEDs lithium battery accessible behind the front flap 1 slot for one 2½-inch hard disk or SSD behind the front flap 1 slot for one CFast flash card behind the front flap passive cooling without fan with a heat sink 5 cm (2") free space on top and bottom of the PC necessary for air circulation protection class IP 20 operating temperature 0...55 °C weight of the basic configuration 1.75 kg (3.9 lbs) compact dimensions (W x H x D) 65 x 208 x 119 mm (2.6" x 8.2" x 4.7") without mounting plate

Features	C6925-0010
Processor	Intel® Celeron® ULV
Motherboard	3½-inch
Slots	1 Mini PCI slot
Free slots	1 Mini PCI slot
Max. card length	Mini PCI
Memory	1...8 GB DDR3 RAM
Graphic adapter	on-board
Ethernet	2 on-board
Hard disks/flash	2½-inch HDD or SSD and/or 1 x CFast or 2 x CFast
RAID 1	2 x CFast
Power supply	24 V DC
Recommendation	recommended for new projects
Further information	for further options, technical drawings, documentations, etc. see www.beckhoff.com/C6925



C6930 | Control cabinet Industrial PC

C6930	C6930-0010	C6930-0020	C6930-0030	C6930-0040
Housing	industrial PC for space-saving control cabinet installation			
	mounting sheet at the rear wall	mounting sheet at the rear wall	mounting sheet at the rear wall	mounting sheet at the rear wall
	all connectors on the front	all connectors on the front	all connectors on the front	all connectors on the front
	status LEDs	status LEDs	status LEDs	status LEDs
	lithium battery accessible behind the front flap			
	2 slots for 2½-inch hard disks or SSDs behind the front flap			
	1 slot for one Compact Flash card (C6930-0010) or CFast flash card (C6930-0020, -0030 or -0040) behind the front flap			
	2 brackets for additional interfaces installed ex factory	2 PCIe module slots to plug-in Beckhoff PCIe modules or to lead out interfaces of the motherboard ex factory	2 PCIe module slots to plug-in Beckhoff PCIe modules or to lead out interfaces of the motherboard ex factory	2 PCIe module slots to plug-in Beckhoff PCIe modules or to lead out interfaces of the motherboard ex factory
	fan cartridge with speed control and double ball bearing fans, accessible from the front			
	5 cm (2") free space above and under the PC required for air circulation			
	protection class IP 20	protection class IP 20	protection class IP 20	protection class IP 20
	operating temperature 0...55 °C	operating temperature 0...55 °C	operating temperature 0...55 °C	operating temperature 0...55 °C
	weight of the basic configuration 2.1 kg (4.6 lbs)			
	compact dimensions (W x H x D) 89 x 231 x 119 mm (3.5" x 9.1" x 4.7") without mounting plate			

Features	C6930-0010	C6930-0020	C6930-0030	C6930-0040
Processor	Intel® Core™ Duo or Core™2 Duo	Intel® Core™2 Duo	Intel® Celeron® up to Core™2 Duo	up to Core™ i3/i5/i7 2 nd generation
Motherboard	3½-inch	3½-inch	3½-inch	3½-inch
Slots	1 Mini PCI slot	1 Mini PCI and 2 PCIe modules, optionally 2 plug-in card slots	1 Mini PCI and 2 PCIe modules, optionally 2 plug-in card slots	1 Mini PCI and 2 PCIe modules, optionally 2 plug-in card slots
Free slots	1 Mini PCI slot	1 Mini PCI and 2 PCIe modules, optionally 2 PCI/PCIe plug-in card slots	1 Mini PCI and 2 PCIe modules, optionally 2 PCI/PCIe plug-in card slots	1 Mini PCI and 2 PCIe modules, optionally 2 PCI/PCIe plug-in card slots



C6930-0020/-0030/-0040 with plug-in card slots



Features	C6930-0010	C6930-0020	C6930-0030	C6930-0040
Max. card length	Mini PCI	Mini PCI and 2 PCIe modules, optionally 2 x 190 mm plug-in cards	Mini PCI and 2 PCIe modules, optionally 2 x 190 mm plug-in cards	Mini PCI and 2 PCIe modules, optionally 2 x 190 mm plug-in cards
Memory	1...3 GB DDR2RAM	1...8 GB DDR3 RAM	1...8 GB DDR3 RAM	2...16 GB DDR3 RAM
Graphic adapter	on-board	on-board	on-board	integrated in the processor
Ethernet	2 on-board	2 on-board	2 on-board	2 on-board
Hard disks/flash	1 or 2 x 2½-inch HDD or SSD and/or 1 x CF card or 2 x CF card	1 or 2 x 2½-inch HDD or SSD and/or 1 x CF card or 2 x CF card	1 or 2 x 2½-inch HDD or SSD and/or 1 x CFast or 2 x CFast	1 or 2 x 2½-inch HDD or SSD and/or 1 x CFast or 2 x CFast
RAID 1	2 x 2½-inch HDD	2 x 2½-inch HDD	2 x 2½-inch HDD or 2 x CFast	2 x 2½-inch HDD or 2 x CFast
Power supply	24 V DC	24 V DC	24 V DC	24 V DC
Recommendation	not recommended for new projects	available	recommended for new projects	recommended for new projects
Further information	for further options, technical drawings, documentations, etc. see www.beckhoff.com/C6930			

C6930-0020, -0030, -0040 | Extension for PCI and PCIe plug-in cards

Ordering information	Options for C6930-0020, -0030, -0040
FC9062	gigabit Ethernet PCIe module for PCs with Beckhoff PCIe module slots, 2-channel, PCI Express x1 bus
C9900-B507	2 PCIe plug-in card slots on the passive backplane integrated inside C6930, to plug-in PCIe x1 cards up to 190 mm (6.3") length. The connectors of the plug-in cards are located at the top side of the PC on the right. The width of the PC housing is increased by 70 mm (2.76"), the depth is increased by 18 mm (0.7").
C9900-B511	2 PCI plug-in card slots on the passive backplane integrated inside C6930, to plug-in PCI cards up to 190 mm (6.3") length. The connectors of the plug-in cards are located at the top side of the PC on the right. The width of the PC housing is increased by 70 mm (2.76"), the depth is increased by 18 mm (0.7").
C9900-B515	1 PCI and 1 PCIe plug-in card slot on a passive backplane integrated inside C6930, to plug-in one PCI and one PCIe x1 card up to 190 mm (6.3") length. The connectors of the plug-in cards are located at the top side of the PC on the right. The width of the back cover is increased by 70 mm (2.76"), the depth is increased by 18 mm (0.7").

Industrial PC accessories

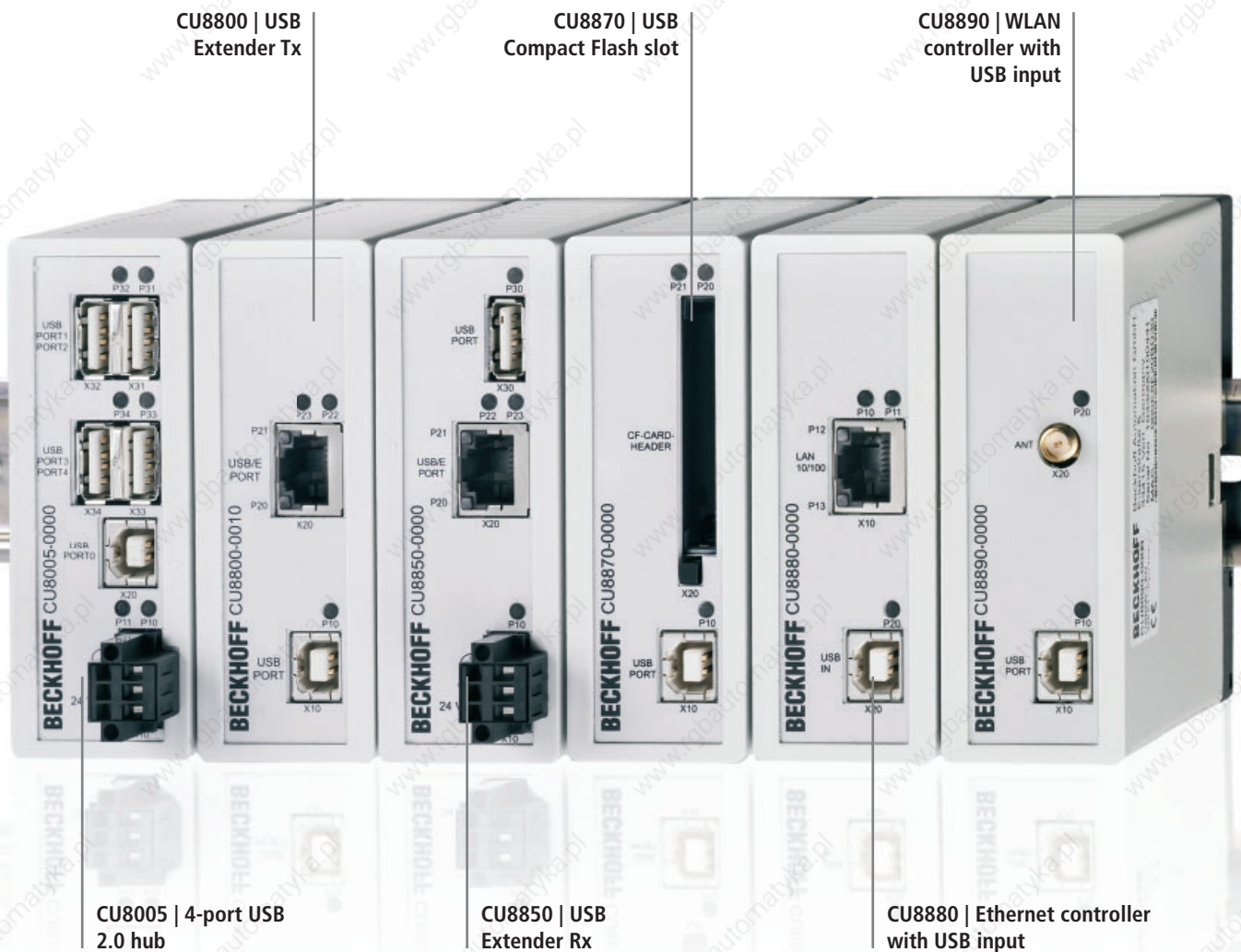

CU8810 | DVI splitter for CP69xx and CP79xx

A common application in machine and plant construction is the simultaneous display of a PC screen on several monitors. Up to four CP69xx or CP79xx DVI/USB Control Panels can be connected to a PC via the CU8810 DVI splitter. Thanks to DVI/USB extension technology, the Control Panels can each be connected at distances of 50 m from the DVI splitter. PCs with two DVI outputs, which are configured as extended desktops, generate two different screen contents. Both DVI outputs can be fed into the DVI splitter. Using DIP switches, the four DVI outputs can each be assigned to one of the two DVI inputs, so that the Control Panels show either the left or the right half of the desktop, as selected.



Technical data	CU8810 DVI splitter for CP69xx and CP79xx
	metal housing for DIN rail installation
	compact industrial design
	2 DVI-D inputs
	4 DVI-D outputs
	assignment of the 4 DVI outputs to the 2 inputs freely configurable via DIP switches
	DVI inputs and outputs with full DVI data range up to 1.65 Gbit/s
	unused DVI input and outputs can be switched off to save energy
	1 USB input with USB B socket
	4-port USB hub with 4 USB Extended outputs as RJ 45 connectors
	USB transfer rate up to 12 Mbit/s for USB 1.1, downwards compatible to USB 1.0
	protection class IP 20
	operating temperature 0...55 °C
	dimensions (W x H x D) 146.5 x 100 x 38 mm (5.8" x 4" x 1.5")
	24 V DC power supply

CU8800, CU8850 | USB extension

The USB specification allows a distance of 5 m between the PC and the USB devices. A further 5 metres of cable can be added by using a USB hub. In the construction of machines and plants, larger distances must be bridged without having to insert a USB hub every 5 metres. The CU8800 USB Extender sends the USB signal via a CAT5 cable that can be up to 50 m long to the CU8850 USB Extended receiver, which converts the signal back to USB. Data rates of up to 12 Mbit/s can be transmitted. Both USB Extender boxes are designed for DIN rail mounting. The CU8800 transmitter is powered by the PC. The CU8850 receiver has an integrated 24 V DC power supply unit.



Technical data	CU8800 USB Extender Tx	CU8850 USB Extender Rx
	USB Extended transmitter box	USB Extended receiver box
	1 USB input with USB B socket to be connected to the PC in maximum 1 m distance	1 USB Extended input with RJ 45 socket for up to 50 m CAT5 cable
	1 USB Extended output with RJ 45 socket for up to 50 m CAT5 cable	1 USB output with USB A socket to be connected to an USB device in maximum 5 m distance
	–	quick error analysing with diagnostic LEDs
	plastic housing for DIN rail installation	plastic housing for DIN rail installation
	USB transfer rate up to 12 MBit/s for USB 1.1, downwards compatible to USB 1.0	
	protection class IP 20	protection class IP 20
	operating temperature 0...55 °C	operating temperature 0...55 °C
	dimensions (W x H x D) 34 x 98 x 77 mm (1.3" x 3.9" x 3")	dimensions (W x H x D) 34 x 98 x 77 mm (1.3" x 3.9" x 3")
	power supply via USB	24 V DC power supply

CU8005 | 4-port USB 2.0 hub

The CU8005 USB hub for DIN rail-mounting has four ports and supports the USB 2.0 data transfer rate of 480 Mbit/s, but is also compatible with slower USB standards. Whereas the USB standard prescribes a power supply of 5 V/0.5 A for each USB downstream output, the CU8005 even provides 5 V/1 A for each USB device.



Technical data	CU8005 4-port USB 2.0 hub
	1 USB 2.0 input with USB B socket
	4 USB 2.0 outputs with USB A socket
	delivers up to 1 A supply current at each USB downstream output
	USB transfer rate up to 480 Mbit/s, compatible to all USB standards
	plastic housing for DIN rail installation
	protection class IP 20
	operating temperature 0...55 °C
	dimensions (W x H x D) 34 x 98 x 77 mm (1.3" x 3.9" x 3")
	24 V DC power supply

CU8870 | USB Compact Flash slot

The CU8870 offers a Compact Flash socket with USB connector. The Compact Flash cards are hot-plug capable in the CU8870 and can hence be plugged and unplugged like removable data storage devices for exchanging data with other PCs during operation. Together with the CU8800 and the CU8850, this CF socket can be mounted on a DIN rail at a distance of up to 50 m from the PC.



Technical data	CU8870 USB Compact Flash slot
	Compact Flash slot for CF cards type I and II
	front LED indicators for: PWR (power), LOCK (read only) and CF access
	1 USB 2.0 input with USB B socket
	USB transfer rate up to 480 Mbit/s, compatible to all USB standards
	plastic housing for DIN rail installation
	protection class IP 20
	operating temperature 0...55 °C
	dimensions (W x H x D) 34 x 98 x 77 mm (1.3" x 3.9" x 3")
	power supply via USB

CU8871 | USB CFast slot

The CU8871 offers a CFast socket with USB connector in a compact housing for DIN rail mounting. CFast Flash cards are used in the industrial environment as data memory for process and control data. The CFast cards are hot-plug capable in the CU8871 and can hence be plugged and unplugged like removable data storage devices for exchanging data with other PCs during operation. The USB 3.0 connection offers the highest data transfer rate possible with a CFast card, but the CFast adapter can also be connected to PCs with a USB 2.0 interface. Power is also supplied via USB. Status LEDs indicate whether the CU8871 is connected in addition to indicating data accesses and providing information on the write protection of the inserted CFast card.



Technical data	CU8871 USB CFast slot
	CFast slot
	status LEDs for PWR (power), LOCK (only read permission) and CFast (access)
	1 USB 3.0 input with USB B socket
	compatible to all USB standards
	plastic housing for DIN rail installation
	protection class IP 20
	operating temperature 0...55 °C
	dimensions (W x H x D) 34 x 98 x 77 mm (1.3" x 3.9" x 3")
	power supply via USB
	1 m USB connector cable

CU8880 | Ethernet controller with USB input

With the CU8880 USB-to-LAN adapter, Industrial PCs can be extended with an additional industrially-suited and independent Ethernet interface. The CU8880 is used for necessary IT communication. It is not suitable for EtherCAT or real-time Ethernet communication. However, the on-board Ethernet interfaces of the respective Industrial PCs are available for this. Drivers for the USB-to-LAN adapter are available for Windows XP, Windows 7 as well as Windows Embedded Standard.



Technical data	CU8880 Ethernet controller with USB input
	Ethernet controller box
	1 USB 2.0 input with USB B socket
	1 Ethernet interface with 1 x 10/100BASE-T connector RJ 45
	not suitable for real-time Ethernet or EtherCAT
	plastic housing for DIN rail installation
	protection class IP 20
	operating temperature 0...55 °C
	dimensions (W x H x D) 34 x 98 x 77 mm (1.3" x 3.9" x 3")
	power supply via USB

CU8890 | WLAN controller with USB input

The industrial grade CU8890 WLAN controller is based on the standard IEEE 802.11 b/g and is designed for DIN rail installation. Connected to an IPC it offers a fieldbus-independent data exchange. The data exchange module has a reverse SMA plug for connection of various radio antennas. The free choice of antenna enables adaptation to the respective environment. The outdoor range between two modules depends on the environment and can be up to 300 m. The CU8890 can be used either as access-point or as client. Status and data exchange are displayed via LEDs, thereby offering fast and simple diagnostics. Client drivers are available for Windows XP, Embedded Standard as well as Windows CE 6. With the drivers for Windows XP and Embedded Standard, the CU8890 can also operate as an access-point.



Technical data	CU8890 WLAN controller with USB input
	WLAN controller box
	1 USB 2.0 input with USB B socket
	1 antenna connection: reverse SMA connector (RP-SMA)
	IEEE 802.11b/g standard
	bit rate: max. 54 Mbit/s (ad-hoc mode: max. 11 Mbit/s)
	dynamic data rate adaption in mode b: 1, 5, 11 Mbit/s; in mode g: 6, 9, 12, 18, 24, 36, 48, 54 Mbit/s
	not suitable for real-time Ethernet or EtherCAT
	64/128 bit encryption, WEP, WPA, WPA2
	cisco compatible extension CCX, supports PEAP and LEAP
	plastic housing for DIN rail installation
	protection class IP 20
	operating temperature 0...55 °C
	dimensions (W x H x D) 34 x 98 x 77 mm (1.3" x 3.9" x 3")
	power supply via USB

Accessories	Description	
ZS6200-0400	omni-directional antenna 4 dBi, matching cables: ZK6000-0102-0020/-0040 (not included in the scope of supply), see page	654
ZS6100-0900	directional antenna 9 dBi, matching cables: ZK6000-0102-0020/-0040 (not included in the scope of supply), see page	654
ZS6201-0410	rod antenna 4 dBi, 1 m cable with reverse SMA socket (included in the scope of supply), see page	655
ZS6201-0500	rod antenna 5 dBi, direct connection, reverse SMA socket, see page	655

C9900-H35x | USB sticks

The USB stick replaces the floppy disk drive for the exchange of data between PCs that are not networked with one another. With a storage capacity one thousand times larger than a floppy disk and a speed similar to a hard disk, the hot-plug capable data storage device is in demand everywhere PCs are used. The USB stick can also be used for data backups. A 8 GB USB stick can store the contents of 11 CDs, whereby the housing of the Beckhoff stick is so small that no collision with adjacent USB plugs occurs, even when the USB sockets are arranged directly alongside one another. Together with the USB extension comprised of the CU8800 and CU8850, a USB stick can be operated at a distance of 50 m from the PC. In the case of systems with a detached DVI/USB Control Panel, a USB stick can be plugged into either the PC or the Control Panel as desired.



Ordering information	USB sticks
C9900-H356	USB stick, 4 GB, USB 2.0
C9900-H359	USB stick, 8 GB, USB 2.0

C9900-U33x | Battery pack

All Industrial PCs can be equipped with a 24 V power supply unit and an integrated UPS. The UPS supplies the PC with power if the mains power fails. This allows data to be saved on the hard disk or Flash, after which the PC can be shut down properly. A battery pack, which serves as the energy storage device, is mounted on a DIN rail outside the PC.

Rated at 3.4 Ah, the maintenance-free C9900-U330 24 V battery pack offers a very high nominal capacity in a compact package. With their rated capacity of 1.3 Ah, the very compact 24 V battery packs C9900-U332 (vertical mounting) and C9900-U333 (horizontal mounting) are designed for PCs with Intel® Atom™ processor.



Technical data	C9900-U330	C9900-U332, C9900-U333
	battery pack for PCs with 24 V power supply with intergrated UPS	
	metal housing for mounting on norm rail TS35x15 2.3	metal housing for mounting on norm rail TS35x15 2.3
	24 V nominal voltage	24 V nominal voltage
	3.4 Ah nominal capacity (20 h discharge)	1.3 Ah nominal capacity (20 h discharge)
	two 12 V batteries in series connection	two 12 V batteries in series connection
	VRLA AGM Technology = valve regulated lead acid batteries with glass fiber mat inside the separator (VRLA = valve regulated lead acid, AGM = absorbed glass mat technology)	
	maintenance-free	maintenance-free
	9 A fuse by PTC element	9 A fuse by PTC element
	operating temperature 0...50 °C	operating temperature 0...50 °C
	weight 3.3 kg (7.3 lb)	weight 2.1 kg (4.63 lb)
	dimensions (W x H x D)	dimensions (W x H x D)
	157 x 70 x 175 mm (6.2" x 2.8" x 6.9")	C9900-U332: 68.7 x 106.6 x 143.8 mm (4.2" x 2.8" x 5.66") C9900-U333: 106.6 x 68.7 x 143.8 mm (6.2" x 4.2" x 5.66")

FC9062 | Beckhoff PCIe module

The compact PC expansion card with industrial form factor

Beckhoff PCIe modules are highly integrated PCI Express plug-in cards and follow the trend towards ever smaller PCs. The function of PC plug-in cards is integrated in a compact format that is suitable for harsh industrial environments.

Compared with PCI or PCIe plug-in cards, which require a special card holder in the Industrial PC, the Beckhoff PCIe module is a industrially compatible plug-in card that is firmly screwed to the inside of the PC via the plug connector bracket. The PCIe modules can be retro-fitted on site without special PC knowledge. The PC housing does not have to be opened.

The 3½-inch motherboard offers four PCI Express lanes to be distributed to the PCIe module slots or standard plug-in card slots. The result are PCs with module slots and/or slots for plug-in cards. A PCIe module is connected to the motherboard via one PCI Express lane with a data transfer rate of 2 Gigabit. A module can therefore provide two Gigabit Ethernet interfaces, for example. This function was already realised in a PCIe module: the FC9062 module complements the PCs CP62xx, C6515, C6525 and C6930 with two Gigabit Ethernet ports. If two modules are used, these PCs have a total of six Ethernet interfaces, while the PCI Express socket continues to be available for a seventh Ethernet port or a fieldbus interface for PROFIBUS, CANopen, DeviceNet or SERCOS. If only one of the two module slots is equipped with a PCIe module, the second slot is available for feeding motherboard interfaces such as COM ports, USB or sound out of the PC. The connection for a Mini PCI card can also be fed out through the module slots, even if the basic configuration of the PC, e.g. the C6515, does not allow for Mini PCI fieldbus cards.



Ordering information	PCI Express module
FC9062	gigabit Ethernet PC module for PCs with Beckhoff PCIe module slots, 2-channel, PCI Express x1 bus



C9900-A2xx | ADD-IN cards

A common application in machine and plant construction is the display of a PC screen on two monitors simultaneously. The ADD-IN cards offer one or two DVI outputs for PCs with ATX motherboard for Intel® Celeron® or Core™2 Duo, i.e. the Industrial PCs CP65xx-0060, C3xxx-0040, C5102-0040, C6140-0040, C6150-0040, C6240-0040, C6250-0050 and C66xx-0020. The second DVI output is active under Windows and optionally shows the same image as the first DVI connection or different image content, i.e. half the extended desktop in each display.

The ADD-IN cards are available in different versions, i.e. with two external outputs, two internal outputs, or one internal and one external output. An internal output is used for connecting the display in the Panel PC front or for one to three CP-Link cards, each controlling a Control Panel at maximum distance of 100 m from the PC.

The C9900-A257 ADD-IN card with an internal and an external DVI connection

enables an additional DVI/USB Control Panel to be operated at a C3xxx or CP65xx Panel PC. The C9900-A257 enables DVI and CP-Link Control Panels to be connected simultaneously at a C5102 or C6140, C6150, C6240, C6250 or C66xx control cabinet PCs.

A C9900-A258 ADD-IN card with two internal DVI outputs enables connection of additional CP-Link Control Panels at a C3xxx or CP65xx Panel PC. For 19-inch rack PCs and ATX control cabinet PCs CP-Link Control Panels can be configured as extended desktop so that they display different image content.

The C9900-A259 ADD-IN card, which features two external DVI connections, enables two DVI/USB Control Panels to be connected to the C5102, C6140, C6150, C6240, C6250 or C66xx PCs. Via the CU8810 DVI splitter these two DVI outputs can be branched further to up to four Control Panels.

DVI/USB Control Panels can be operated up to 50 m away from the PC using DVI/USB extension technology.

The two-channel ADD-IN card can be configured as an extended desktop to generate different image content. The desktop has twice the display resolution. Each display shows half the screen. The Start menu and the taskbar are shown on one of the two displays and can be moved to the other display. The mouse cursor always jumps to the display on which the operator touches the touch screen. Keyboard entries are always entered in the active window, irrespective of which display this window is currently displayed in. Programs generally start on display no. 1 and can then be moved to the second display. If a window is set to full screen, it will fill the display that previously showed the larger part of the window. In the Windows XP Control Panel the displays can be configured as no. 1 or no. 2, and their relative arrangement can be determined.

Ordering information	ADD-IN cards
C9900-A257	ADD-IN card with one internal DVI interface and one external DVI interface, PCI Express x16 plug-in card
C9900-A258	ADD-IN card with two internal DVI interfaces, PCI Express x16 plug-in card
C9900-A259	ADD-IN card with two external DVI interfaces, PCI Express x16 plug-in card
C9900-A260	ADD-IN card with one external DisplayPort interface, PCI Express x16 plug-in card
C9900-A264	ADD-IN card with one internal DVI interfaces, PCI Express x16 plug-in card
C9900-A265	ADD-IN card with one external DVI interfaces, PCI Express x16 plug-in card



C9900-E2xx | Slotbox for extending Industrial PCs with two plug-in card slots

The slotbox makes PCI Express and PCI slots available outside the IPC as well. The PCI Express bus is fed via a plug connector and cable to a slotbox located up to seven meters (23-ft) away. Users can use the installation space in the control cabinet flexibly and

locate further plug-in cards locally. Both PCI and PCI Express card slots are available by using different versions of the slotbox. The slotbox is made of sturdy aluminium and ideal for use in industrial environments.



PCIe module C9900-E239 for installation in the PC

C9900-E2xx	C9900-E249	C9900-E250	C9900-E251
Technical data	fanless aluminium housing for control cabinet installation		
	2 slots for up to 190 mm long plug-in cards		
	all connectors on the top	all connectors on the top	all connectors on the top
	PCIe x1 input for connection with an Industrial PC with PCIe module C9900-E236 or -E239		
	7 m max. distance between Industrial PC and slotbox		
	1 PCI and 1 PCIe x1 slot	2 PCIe x1 slots	2 PCI slots
	IP 20	IP 20	IP 20
	operating temperature 0...55 °C	operating temperature 0...55 °C	operating temperature 0...55 °C
	weight without plug-in cards 1.7 kg	weight without plug-in cards 1.7 kg	weight without plug-in cards 1.7 kg
	dimensions (W x H x D) 94 x 222 x 132 mm (3.7" x 8.7" x 5.2") without mounting plate		
	24 V DC power supply	24 V DC power supply	24 V DC power supply
C9900-E23x	PCIe modules		
C9900-E236	PCIe modules with external PCIe x1 connector for C5210, CP62xx or C65xx with PCIe module slot		
C9900-E239	PCIe modules with external PCIe x1 connector for C6930		
C9900-K50x	Connection cables for the slotbox		
C9900-K501	connecting cable PCIe x1 external, 1 m		
C9900-K502	connecting cable PCIe x1 external, 3 m		
C9900-K503	connecting cable PCIe x1 external, 5 m		
C9900-K504	connecting cable PCIe x1 external, 7 m		

Panel PC



USB 1.1/2.0

Ethernet TCP/IP

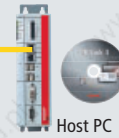

Host PC

Single Desktop

Panel PC 1



USB 1.1/2.0

Ethernet
UDP/IP (TCP/IP)
(Multicast)

Host PC

Multi Desktop

Panel PC 2



USB 1.1/2.0

Panel PC x



USB 1.1/2.0

Panel PC 1

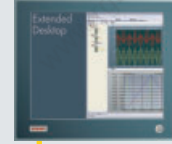

USB 1.1/2.0

Ethernet TCP/IP



Host PC

Extended Desktop

CP-Link 3 | Ethernet- and IP protocol-based desktop transfer software

CP-Link 3 transfers the desktop of a PC via Ethernet to several Panel PCs and the operator mouse and keyboard entries to the host PC. The screen contents are captured by a virtual graphic adapter in the host PC and sent using Ethernet to one or more Panel PCs with Windows operating systems (CE, XP, Windows 7 or Embedded Standard). Networking can be done using cost-effective standard Ethernet cables (CAT 5) which are suitable for drag chains.

Since the data and image transfer are based on TCP/IP, the operating and display functions can be extended using the Internet. Panel PCs can be integrated using the Internet via VPN (Virtual Private Network). A VPN service must be available for the Internet security functions.

Keyboard entries, touch screen and special key functions are transferred from the client to the host PC via Virtual USB. USB devices connected to a Panel PC appear in the host PC like locally plugged-in devices and can be used in the normal way.

Virtual USB emulates a USB root hub in the host PC. If a USB device is plugged into a Panel PC, then the virtual hub logs the

device on to the operating system of the host PC and transparently transmits the ensuing communication. For the operating system, the USB device behaves as though it was directly connected to the PC. Virtual USB transfers the standards USB 1.1 and USB 2.0. As communication takes place using 100 Mbit/s Ethernet, the USB 2.0 transmission performance (480 Mbit/s) is restricted.

Additional input/output devices on the Panel PCs, such as rotary switches, buttons, etc., are read in by the host PC using an additional communication channel. Printers and webcams, which are connected to a Panel PC by means of USB, can be used from the host PC.

The scope of delivery for CP-Link 3 includes host and client software. The host PC may have Windows XP, Windows 7 or Embedded Standard installed. Panel PCs with Windows CE, Windows XP, Windows 7 or Embedded Standard are used as clients. As the application software (PLC/NC, HMI, etc.), once started, runs on the host PC, any necessary software licences are only payable once for the host PC. The client Panel PCs only receive image data. Apart from the operat-

ing system and CP-Link 3, no other software licence is required for the clients. Even for PCs with more than one graphics card only one license per application software is required.

The CP-Link 3 software is available in three versions:

- Single Desktop
- Multi Desktop
- Extended Desktop

Single Desktop

A Panel PC is connected with a host PC via Ethernet and shows the image of the host PC. Communication takes place using TCP/IP.

Keyboard entries, touch screen and special key functions are transferred from the client to the host PC via Virtual USB. USB devices connected to a Panel PC appear in the host PC just like locally connected devices.

Ordering information	CP-Link 3 Single Desktop
CP-Link 3 Single Desktop	Ethernet and IP protocol-based desktop transfer software CP-Link 3
	transfers the desktop of a PC via Ethernet to one Panel PC
	transmission of mouse and keyboard inputs of the client user to the host PC
	connection by Ethernet or Internet, TCP/IP or UDP/IP
	1 virtual graphic adapter
	Virtual USB
	USB devices connected at the client are found by the host PC like a local USB device.
	1 client controllable
	The client shows the screen of the host PC.
	host software for Beckhoff Industrial PCs with Windows XP, Windows 7 or Windows Embedded Standard
	client software for Beckhoff Panel PCs with Windows CE, Windows XP, Windows 7 or Windows Embedded Standard

Multi Desktop

Several Panel PCs are connected with a PC via Ethernet and display the image of the host PC. All connected client Panel PCs show the same image.

Communication takes place using TCP/IP (up to 10 Panel PCs) or via UDP Multicast (up to 255 Panel PCs). The benefit of Multicast lies in the fact that messages can be transferred to several Panel PCs simultaneously without the transmitter bandwidth multiplying by the number of receivers.

Ordering information	CP-Link 3 Multi Desktop
CP-Link 3 Multi Desktop	Ethernet and IP protocol-based desktop transfer software CP-Link 3
	transfers the desktop of a PC via Ethernet to Panel PCs
	transmission of mouse and keyboard inputs of client users to the host PC
	connection by Ethernet or Internet, TCP/IP or UDP/IP (Multicast)
	1 virtual graphic adapter
	Virtual USB
	USB devices connected at a client are found by the host PC like a local USB device.
	Up to 255 clients are controllable in UDP/IP mode, up to 10 clients in TCP/IP mode.
	All clients show the same picture, the screen of the host PC.
	The input devices can be locked at any client by TwinCAT-PLC or via application programming interface (API)
	host software for Beckhoff Industrial PCs with Windows XP, Windows 7 or Windows Embedded Standard
client software for Beckhoff Panel PCs with Windows CE, Windows XP, Windows 7 or Windows Embedded Standard	

Extended Desktop

One or several virtual graphic adapters are used to extend the host PC desktop. The program windows of the application software can be moved to additional monitors covered by the extended desktop. Applications may be started on a specific monitor. The desktop can be extended to up to 9 monitors. CP-Link 3 can transfer the data via Ethernet to several client Panel PCs.

The mouse and keyboard entries of individual clients can be locked via TwinCAT PLC or a software interface (API), in order to prevent interference between several users.

Ordering information	CP-Link 3 Extended Desktop
CP-Link 3 Extended Desktop	Ethernet and IP protocol-based desktop transfer software CP-Link 3
	transfers up to 9 screens of the extended desktop of a PC via Ethernet to Panel PCs
	transmission of mouse and keyboard inputs of client users to the host PC
	connection via Ethernet or Internet, TCP/IP or UDP/IP (Multicast)
	Up to 9 virtual graphic adapters extend the desktop of the host PC.
	Virtual USB
	USB devices connected at a client are found by the host PC like a local USB device.
	Up to 255 clients are controllable in UDP/IP mode, up to 10 clients in TCP/IP mode.
	Each client shows 1 of maximally 9 screens of the extended desktop of the host PC.
	The input devices can be locked at any client by TwinCAT PLC or via application programming interface (API).
	Applications are allocable to one of the additional screens of the extended desktop.
host software for Beckhoff Industrial PCs with Windows XP, Windows 7 or Windows Embedded Standard	
client software for Beckhoff Panel PCs with Windows CE, Windows XP, Windows 7 or Windows Embedded Standard	

Control Panel



Multi-touch Control Panel

- built-in (CP29xx) or mounting arm devices (CP39xx)
- multi-finger touch screen
- 7-, 12-, 15-, 15.6-, 18.5-, 19- and 24-inch displays
- vertical or horizontal variants (portrait/landscape)
- DVI/USB Extended interface

See page **142**

Single-touch Control Panel

- built-in (CP66xx, CP69xx) or mounting arm devices (CP79xx)
- without touch screen, single-finger touch screen or touch pad
- 5.7-, 6.5-, 12-, 15-, 19- and 24-inch displays
- Ethernet (CP66xx) or DVI/USB Extended interface (CP69xx, CP79xx)

See page **148**



► www.beckhoff.com/multitouch

Multi-touch Control Panel | Display sizes

Built-in Control Panel,
front side IP 65



Control Panel,
IP 65 on all sides



Single-touch Control Panel | Display sizes

Built-in Control Panel,
front side IP 65



Control Panel,
IP 65 on all sides



► www.beckhoff.com/ControlPanel

Multi-touch Control Panel CP2xxx and CP3xxx

With Windows 7 the multi-finger touch screen is becoming popular at PCs. Industrial applications are using the projected capacitive multi-touch technology. An anti-reflective glass plate forms the display front. The operation with hand gloves is possible. Five fingers are detected separately even if the distance between the fingers is only 1 cm.

The multi-touch Control Panels are conceived both for control cabinet installation and for the mounting arm installation. The CP29xx built-in Panel series is implemented with IP 65 protection at the front and IP 20 at the rear. The CP39xx Control Panels for mounting arm installation feature all-round IP 65 protection. The panels with DVI/USB Extended

interface be operated up to 50 m away from the Industrial PC.

The following display sizes are available:

Wide screen (16:9)

- 7-inch, resolution of 800 x 480
- 15.6-inch, resolution 1366 x 768
- 18.5-inch, resolution 1366 x 768
- 24-inch, full HD resolution of 1920 x 1080



Further display sizes

- 12-inch, resolution of 800 x 600 (4:3)
- 15-inch, resolution 1024 x 768 (4:3)
- 19-inch, resolution 1280 x 1024 (5:4)

With the option C9900-M575 all of the displays are also available in portrait format.

Customer-specific adaptations for a push-button extension individualise the multi-touch Control Panel series.

Modern, elegant device design

Multi-touch for 5-finger touch

Vertical or horizontal variants (portrait/landscape)

Use of aluminium for extremely robust design

Continuous glass surface – highest resistance to environmental influences

Display formats 4:3, 5:4 or wide-screen 16:9

LED backlight

Narrow housing edges

High protection class IP 65

Push-button extension with emergency stop, also in customer-specific design



► www.beckhoff.com/multitouch



CP29xx | Multi-touch built-in Control Panel with DVI/USB Extended interface

CP29xx	Multi-touch built-in Control Panel
Features	<p>TFT display in seven sizes</p> <ul style="list-style-type: none"> – 7-inch display 800 x 480 – 12-inch display 800 x 600 – 15-inch display 1024 x 768 – 15.6-inch display 1366 x 768 – 18.5-inch display 1366 x 768 – 19-inch display 1280 x 1024 – 24-inch display 1920 x 1080 <p>aluminium housing with glass front, front side IP 65, rear side IP 20</p> <p>multi-finger touch screen</p> <ul style="list-style-type: none"> – multi-finger touch screen driver for Windows 7 – single-finger touch screen driver for Windows XP <p>integrated DVI/USB extension technology</p> <ul style="list-style-type: none"> – DVI-E and USB-E 2.0 enable remote panel operation at a distance of up to 50 m from the PC. – USB-E 2.0 transmits USB 2.0 with 480 Mbit/s. – DVI-E input is compatible to the standard DVI output of a PC. <p>USB 3.0 input for the direct connection to a standard USB output of a PC with distances of up to 5 m</p> <p>2-port USB 3.0 socket inside the Control Panel backplane, for USB-E 2.0 limited to USB 2.0</p> <p>all connectors at the lower rear side</p> <p>24 V power supply</p> <p>operating temperature 0...55 °C</p>
Further information	for further options, technical drawings, documentations, etc. see www.beckhoff.com/CP29xx

Ordering information	Multi-touch built-in Control Panel with DVI/USB Extended interface
CP2907-0000	7-inch display 800 x 480, multi-finger touch screen
CP2912-0000	12-inch display 800 x 600, multi-finger touch screen
CP2915-0000	15-inch display 1024 x 768, multi-finger touch screen
CP2916-0000	15.6-inch display 1366 x 768, multi-finger touch screen
CP2918-0000	18.5-inch display 1366 x 768, multi-finger touch screen
CP2919-0000	19-inch display 1280 x 1024, multi-finger touch screen
CP2924-0000	24-inch display 1920 x 1080, multi-finger touch screen



CP39xx | Multi-touch Control Panel with DVI/USB Extended interface

CP39xx	Multi-touch Control Panel
Features	<p>TFT display in seven sizes</p> <ul style="list-style-type: none"> – 7-inch display 800 x 480 – 12-inch display 800 x 600 – 15-inch display 1024 x 768 – 15.6-inch display 1366 x 768 – 18.5-inch display 1366 x 768 – 19-inch display 1280 x 1024 – 24-inch display 1920 x 1080 <p>aluminium housing with glass front, protection class IP 65</p> <p>multi-finger touch screen</p> <ul style="list-style-type: none"> – multi-finger touch screen driver for Windows 7 – single-finger touch screen driver for Windows XP <p>integrated DVI/USB extension technology</p> <ul style="list-style-type: none"> – DVI-E and USB-E 2.0 enable remote panel operation at a distance of up to 50 m from the PC. – USB-E 2.0 transmits USB 2.0 with 480 Mbit/s. – DVI-E input is compatible to the standard DVI output of a PC. <p>connection via 3 round connectors (IP 65) for DVI, USB-E 2.0 and 24 V power supply unit in the backplane</p> <p>24 V power supply</p> <p>operating temperature 0...55 °C</p>
Further information	for further options, technical drawings, documentations, etc. see www.beckhoff.com/CP39xx
Ordering information	Multi-touch Control Panel with DVI/USB Extended interface
CP3907-0000	7-inch display 800 x 480, multi-finger touch screen
CP3912-0000	12-inch display 800 x 600, multi-finger touch screen
CP3915-0000	15-inch display 1024 x 768, multi-finger touch screen
CP3916-0000	15.6-inch display 1366 x 768, multi-finger touch screen
CP3918-0000	18.5-inch display 1366 x 768, multi-finger touch screen
CP3919-0000	19-inch display 1280 x 1024, multi-finger touch screen
CP3924-0000	24-inch display 1920 x 1080, multi-finger touch screen



C9900-G00x, -G01x | Push-button extension for built-in multi-touch panels

C9900-G00x, -G01x	Push-button extension for built-in multi-touch panels
Features	push-button extension for CP2xxx
	push-button extension below
	push-button keys with signal lamp, type RAFI RAFIX 22FS, round, 30 mm
	1 emergency stop key, type RAFI RAFIX 22FS
	labels for push-button caps for individual marking of each push-button
	All push-buttons are transmitted via USB with one normally-open contact.
	Additionally, all push-buttons are directly wireable with a second normally-open contact via a terminal row.
	All signal lamps are transmitted via USB only.
	Selector switches and keylock switches as well as other elements from the series RAFIX 22FS are integrateable.

Ordering information	Push-button extension for built-in multi-touch panels
C9900-G002	push-button extension for CP2x12 12" landscape: 4 push-button keys and 1 emergency stop key
C9900-G003	push-button extension for CP2x15 15" landscape: 7 push-button keys and 1 emergency stop key
C9900-G004	push-button extension for CP2x16 15.6" landscape: 8 push-button keys and 1 emergency stop key
C9900-G005	push-button extension for CP2x18 18.5" landscape: 10 push-button keys and 1 emergency stop key
C9900-G006	push-button extension for CP2x19 19" landscape: 9 push-button keys and 1 emergency stop key
C9900-G007	push-button extension for CP2x24 24" landscape: 13 push-button keys and 1 emergency stop key
C9900-G012	push-button extension for CP2x12 12" portrait: 3 push-button keys and 1 emergency stop key
C9900-G013	push-button extension for CP2x15 15" portrait: 4 push-button keys and 1 emergency stop key
C9900-G014	push-button extension for CP2x16 15.6" portrait: 4 push-button keys and 1 emergency stop key
C9900-G015	push-button extension for CP2x16 15.6" portrait: 3 push-button keys and 1 emergency stop key
C9900-G016	push-button extension for CP2x19 19" portrait: 7 push-button keys and 1 emergency stop key
C9900-G017	push-button extension for CP2x24 24" portrait: 6 push-button keys and 1 emergency stop key



C9900-G02x, -G03x | Push-button extension for multi-touch panels with mounting arm

C9900-G02x, -G03x	Push-button extension for multi-touch panels with mounting arm
Features	push-button extension for CP3xxx
	push-button extension below
	push-button keys with signal lamp, type RAFI RAFIX 22FS, round, 30 mm
	1 emergency stop key, type RAFI RAFIX 22FS
	labels for push-button caps for individual marking of each push-button
	All push-buttons are transmitted via USB with one normally-open contact.
	Additionally, all push-buttons are directly wireable with a second normally-open contact via a terminal row.
	All signal lamps are transmitted via USB only.
	aluminium cable channel to the mounting arm adapter on the backside
	Selector switches and keylock switches as well as other elements from the series RAFIX 22FS are integrateable.

Ordering information	Push-button extension for multi-touch panels with mounting arm
C9900-G022	push-button extension for CP3x12 12" landscape: 4 push-button keys and 1 emergency stop key
C9900-G023	push-button extension for CP3x15 15" landscape: 7 push-button keys and 1 emergency stop key
C9900-G024	push-button extension for CP3x16 15.6" landscape: 8 push-button keys and 1 emergency stop key
C9900-G025	push-button extension for CP3x18 18.5" landscape: 10 push-button keys and 1 emergency stop key
C9900-G026	push-button extension for CP3x19 19" landscape: 9 push-button keys and 1 emergency stop key
C9900-G027	push-button extension for CP3x24 24" landscape: 13 push-button keys and 1 emergency stop key
C9900-G032	push-button extension for CP3x12 12" portrait: 3 push-button keys and 1 emergency stop key
C9900-G033	push-button extension for CP3x15 15" portrait: 4 push-button keys and 1 emergency stop key
C9900-G034	push-button extension for CP3x16 15.6" portrait: 4 push-button keys and 1 emergency stop key
C9900-G035	push-button extension for CP3x18 18.5" portrait: 4 push-button keys and 1 emergency stop key
C9900-G036	push-button extension for CP3x19 19" portrait: 7 push-button keys and 1 emergency stop key
C9900-G037	push-button extension for CP3x24 24" portrait: 6 push-button keys and 1 emergency stop key

Single-touch Control Panel CP6xxx and CP7xxx

What frame does an image need?

The carefully planned use of design elements gives the Control Panel its reserved and elegant appearance.

The open design possibilities of a membrane keyboard are fully exploited here. The robust keyboard ensures that the IP 65 protection class is retained as if new, even after long use in a tough industrial environment.

Light emitting diodes are integrated into the keys, while slide-in labels mean that exchangeable key identification can match the needs of the plant.

The emergency stop at the Control Panel

Push-button extensions in the design of the Control Panel make it thicker, but permit the application-specific arrangement of electromechanical keys and other compo-

nents such as all kinds of switches, barcode scanners, graycode switches and handwheels. External housings can be attached to either side of the Control Panel. The signal leads may be laid separately or can be operated via USB.

Assembly

The back plate of the Control Panel series CP7xxx offers a free surface for a variety of assembly methods, for example a mounting arm system.





Mounting arm



Additional keyboard in IP 65



Touch pad



USB socket in IP 65

Control Panel for installation in the control cabinet door

The built-in Control Panels CP6xxx are designed for control cabinet installation. Only 4 mm of the front are visible in front of the control cabinet wall. Installation via pull-out clamping levers makes the process very simple without loose parts.

The built-in Control Panels CP66xx are available with 5.7-, 6.5-, 12- or 15-inch TFT display, CP69xx in addition with 19- or 24-inch TFT display, with touch screen or touch pad, as a monitor without keyboard with different membrane keyboard models up to full alphanumeric keyboards with 10 PLC special keys and 10 LEDs. The same range of push-button extensions with elec-

tromechanical keys as for the CP7xxx series is available.

The built-in Control Panels are connected to the PC by two different interfaces:

- CP66xx "Economy" Ethernet Control Panel with Intel® IXP processor for Windows CE, with 2 Ethernet interfaces
- CP69xx "Economy" Control Panel with DVI/USB Extended interface for distances of up to 50 m

The Ethernet Control Panels with integrated processor can be used as an independent controller. For higher performance with Intel® Core™ Duo and Core™2 Duo the built-in Panel PCs CP62xx are available with the same front design.

The Control Panel toolkit

A housing that can be dimensioned precisely in line with the needs of the particular application according to the customer's wishes can be combined with an individually designed membrane keyboard. This puts customisation on a new footing at Beckhoff. Hardly one Control Panel is like another, and yet mass production is in operation.

The Bus Terminal interface integrated into the Control Panel permits the connection of standard Beckhoff Bus Terminals to realise handwheels, graycode switches, buttons, switches, indicator lamps or other components without any additional wiring. Such elements can be integrated into the Control Panel and connected to the PC via USB.

Aluminium housing in IP 65

Single-touch screen or glass plate

Interchangeable logo



Push-button extension with emergency stop

► www.beckhoff.com/ControlPanel

Customised Beckhoff CP6xxx/CP7xxx Control Panels

- cost-effective implementation of company logos in form of a slide-in label for standard Control Panels
- complete revision of the colour scheme of the front membrane based on the corporate design of the company
- customised keyboard extensions according to customer specifications
- realisation of customer-specific bracket adapter plates for integrating different bracket systems
- realisation of complex operating terminals with fieldbus connections (PROFIBUS, Lightbus, CANopen, Ethernet, ...)
- modification of the mechanical/electrical connection of the devices according to the local situation
- development and realisation of the design jointly with the customer



Individual housing construction



Stainless steel Panel PC



Push-button extension with hand wheel

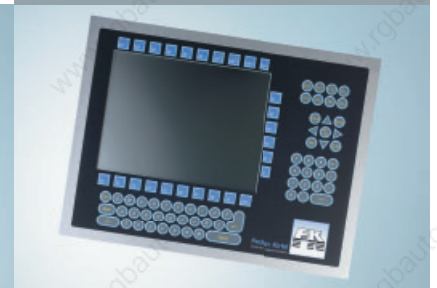

Front membrane design with modified colour scheme and different size membrane keys



Control solution for blow molding machines



Individual housing construction



Modified membrane keypad colour scheme and keypad matrix



Panel PC for injection molding applications



Complex operating terminal with fieldbus connection



Individual housing design, colour scheme and key shape/layout according to customer requirements



Customer-specific front laminate



Extension with joystick, graycode switch and incremental encoder



Multifunctional terminal



Individual housing construction for flush-mounted installation



Customised colour scheme with customer-specific, separate key extension



Keyboard with larger number and higher density of membrane keys



Integration of a barcode scanner and signal transducer



Extension with additional display, incremental encoders and switch elements



Individual housing adaptation

CP66xx | "Economy" built-in Control Panel with Ethernet interface

CP66xx Ethernet Control Panels have a wide range of uses including independent Panel PC, remote desktop display, or server terminal. A PC with Microsoft Windows XP Professional can transfer its image to an Ethernet Control Panel via the remote desktop function. The Ethernet connection between PC and Control Panel can bridge almost any distance, even via the internet.

The image of the PC can optionally be displayed on one of several Control Panels distributed across large systems. When a user logs into an Ethernet Control Panel, the other panels are logged out since Windows XP Professional only has one desktop license. A Windows 2003 server enables all Control Panels to be used simultaneously as independent terminals with different display

content. In each case communication takes place via one of the two 100 Mbit Ethernet interfaces integrated in the rear of the Control Panel. The processor of the Control Panel is only used for setting up the image on the display and for querying the keyboard and mouse or touch screen. Application software is installed on the server and executed by the high-performance processor of the server.



Front laminates



Without keys



Function keys



Numeric keyboard



Alphanumeric keyboard

Data can be entered simultaneously at the different Ethernet Control Panels. In contrast to a PC with a multi-channel graphics card, each Ethernet Control Panel connected to the terminal server has its own mouse and keyboard cursor, so that several operators can work on the same system at the same time. If the same image is to be displayed on several displays, it is

advisable to use CP-Link 3 as described on page 138.

The Ethernet Panels can also be used as independent Panel PCs. These devices are ideally suited as small controllers for machine construction and plant engineering applications in conjunction with the TwinCAT automation software.

Ethernet Control Panel

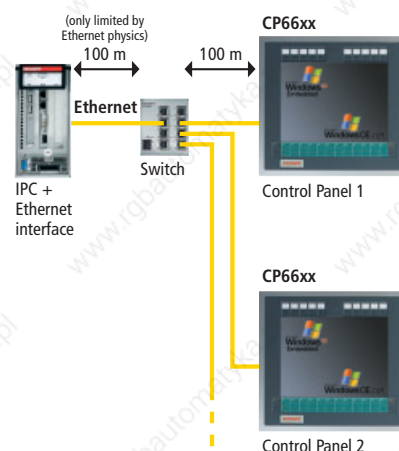

TFT display

1 Mini PCI slot for fieldbus cards

Compact Flash

Lithium battery easily accessible

1 serial interface RS232



3½-inch motherboard

On-board dual Ethernet adapter

Power supply 24 V DC

2 USB ports

► www.beckhoff.com/CP66xx



CP66xx | “Economy” built-in Control Panel with Ethernet interface

Ordering information	without touch screen	with single-touch screen	with touch pad
Display only			
5.7-inch display 640 x 480	CP6607-0000-0000	CP6607-0001-0000	
6.5-inch display 640 x 480	CP6609-0000-0000	CP6609-0001-0000	
12-inch display 800 x 600	CP6601-0000-0000	CP6601-0001-0000	
15-inch display 1024 x 768	CP6602-0000-0000	CP6602-0001-0000	
Display only, USB A socket in the front			
12-inch display 800 x 600	CP6601-0020-0000	CP6601-0021-0000	
15-inch display 1024 x 768	CP6602-0020-0000	CP6602-0021-0000	
With function keys			
6.5-inch display 640 x 480	CP6619-0000-0000	CP6619-0001-0000	
12-inch display 800 x 600	CP6611-0000-0000	CP6611-0001-0000	
15-inch display 1024 x 768	CP6612-0000-0000	CP6612-0001-0000	
Numeric keyboard			
6.5-inch display 640 x 480	CP6629-0000-0000	CP6629-0001-0000	
12-inch display 800 x 600	CP6621-0000-0000	CP6621-0001-0000	CP6621-0002-0000
15-inch display 1024 x 768	CP6622-0000-0000	CP6622-0001-0000	CP6622-0002-0000
Alphanumeric keyboard			
12-inch display 800 x 600	CP6631-0000-0000	CP6631-0001-0000	CP6631-0002-0000
15-inch display 1024 x 768	CP6632-0000-0000	CP6632-0001-0000	CP6632-0002-0000



Without keys



Function keys



Numeric keyboard



Alphanumeric keyboard

CP66xx	"Economy" built-in Control Panel
Features	TFT display in four sizes <ul style="list-style-type: none"> – 5.7-inch display 640 x 480 – 6.5-inch display 640 x 480 – 12-inch display 800 x 600 – 15-inch display 1024 x 768
	aluminium front with sheet-steel rear cover, front side IP 65, rear side IP 20
Options	front laminate in four variants <ul style="list-style-type: none"> – only display – function keys and 10 PLC special keys with LED – numeric keyboard and 10 PLC special keys with LED – alphanumeric PC keyboard in US layout and 10 PLC special keys with LED
	integrated PC, 3½-inch motherboard for Intel® IXP processor with XScale® technology
	Intel® IXP420 with XScale® technology, clock frequency 533 MHz
	128 MB on-board RAM
	32 MB on-board flash
	slot for 1 Compact Flash card accessible from the rear side
	lithium battery of the system clock, accessible from the rear side
	on-board graphic adapter, graphic chip SM501 (max. resolution 1024 x 768)
	1 Mini PCI slot free, e.g. for a fieldbus interface card
	2 USB ports
	2 RJ 45 Ethernet connectors 10/100 Mbps
	1 RS232 serial port, D-sub, 9-pin
	all connectors at the lower rear side
	24 V power supply
	operating temperature 0...55 °C
	pull-out clamping levers for fast installation without loose parts
	operating system Microsoft Windows CE, English
Stainless steel options	touch screen pen with wall holder
	push-button extension with electromechanical switches and keys
	Compact Flash card
	1 Mini PCI slot for cards installed ex factory with fieldbus interface, Ethernet port or NOVRAM
Further information	TwinCAT run-time for Windows CE
	wall mounting frame for building installation
	stainless steel front (1.4301) with bevelled edges at top and bottom and touch screen for CP660x
	for further options, technical drawings, documentations, etc. see www.beckhoff.com/CP66xx

CP69xx, CP79xx | "Economy" Control Panel with DVI/USB Extended interface

The digital visual interface (DVI), defined as successor to analog VGA connections, digitally transfers the PC image to the display. The universal serial bus (USB) enables connection of input devices and drives to the PC. DVI/USB Extended enables CP69xx and CP79xx "Economy" Control Panels to be operated at a distance of up to 50 metres from the PC. Apart from a graphics card

or a motherboard with DVI output and the USB port available with every motherboard, no additional card is required in the PC.

CP79xx Control Panels are designed for mounting arm installation. They offer all-round IP 65 protection. To this end they are equipped via industrial IP 65 round connectors for DVI or USB Extended and the 24 V power supply.

The CP69xx built-in Control Panels are connected via standard USB and DVI connectors and feature an industrial pin contact strip for the 24 V power supply. A 2-port USB socket in the rear panel enables connection of keyboard, mouse, USB stick or CD/DVD drive. The integrated USB 1.1 hub enables a transfer rate of 12 Mbit/s.



DVI interface

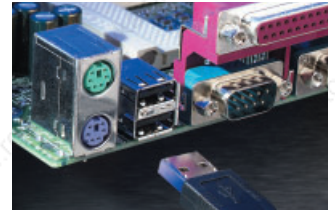

USB interface





CP69xx | "Economy"
built-in Control Panel



CP79xx | "Economy"
Control Panel

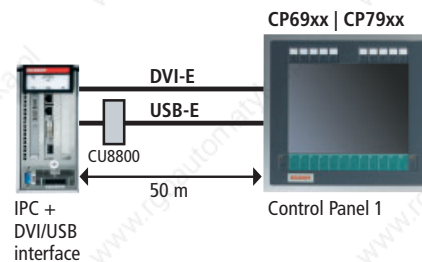

DVI/USB Extended

DVI/USB Extended

The DVI/USB Extended technology integrated in each CP69xx and CP79xx "Economy" DVI/USB panel enables remote panel operation at a distance of up to 50 m from the PC via standard cables. The graphics signal is transferred directly via DVI cable over a maximum distance of 50 m, while the USB signal is transferred to a CAT 5 cable at the PC in order to extend the 5 m limit of the USB specification to a distance of up to 50 m.

A 50 m DVI cable has 10 times the length allowed by the DVI specification. Such a cable length leads to strong distortion of the graphics signal on arrival at the Control Panel. The CP69xx "Economy" Control Panel features a signal processor that restores the DVI signal. Since it is a digital

signal, it can be fully restored. The display shows a perfect image without interference. The PC requires a conventional DVI output. An on-board graphics controller such as Intel® Extreme Graphic or a graphics card can be used.

For USB the specification requires installation of a hub every 5 m. In order to realise a distance of 50 m without hubs, with USB Extended the USB signal is converted so that it can be transferred via 50 m CAT 5 cables with RJ 45 connectors commonly used for Ethernet wiring. In the Control Panel the signal is converted back to USB. Through the 12 Mbit/s transfer rate a USB 1.1 interface is available in the Control Panel. In addition to touch screen, membrane keyboard and push-button extension, a hub in the Control

Panel enables connection of two external USB devices such as keyboard, mouse, USB stick or CD/DVD drive. However, no further USB hub can be connected to the Control Panel. The PC must have a USB 1.1 or USB 2.0 interface. The CU8800 USB-to-USB Extended converter box requires no auxiliary power supply. It has a USB input and an RJ 45 USB Extended output. The box together with all required cables is offered as a set for distances of 10, 20, 30, 40 or 50 m between the PC and the Control Panel. For distances up to 5 m the PC and the Control Panels CP69xx can be connected directly via a USB cable. The Control Panels CP79xx are connected via the adapter CU8800, even at short distance.

5.7-, 6.5-, 12-, 15-, 19- or
24-inch TFT display

DVI Extended input for distances
up to 50 m to the PC

USB Extended input for distances
up to 50 m to the PC



2 USB ports for the
connection of keyboard,
mouse or storage media

Power supply 24 V DC

USB input for distances
up to 5 m to the PC

► www.beckhoff.com/CP69xx
► www.beckhoff.com/CP79xx



CP69xx | "Economy" built-in Control Panel with DVI/USB Extended interface

Ordering information	without touch screen	with single-touch screen	with touch pad
Display only			
5.7-inch display 640 x 480	CP6907-0000-0000	CP6907-0001-0000	
6.5-inch display 640 x 480	CP6909-0000-0000	CP6909-0001-0000	
12-inch display 800 x 600	CP6901-0000-0000	CP6901-0001-0000	
15-inch display 1024 x 768	CP6902-0000-0000	CP6902-0001-0000	
19-inch display 1280 x 1024	CP6903-0000-0000	CP6903-0001-0000	
24-inch display 1920 x 1200	CP6904-0000-0000	CP6904-0001-0000	
Display only, USB A socket in the front			
12-inch display 800 x 600	CP6901-0020-0000	CP6901-0021-0000	
15-inch display 1024 x 768	CP6902-0020-0000	CP6902-0021-0000	
19-inch display 1280 x 1024	CP6903-0020-0000	CP6903-0021-0000	
24-inch display 1920 x 1200	CP6904-0020-0000	CP6904-0021-0000	
With function keys			
6.5-inch display 640 x 480	CP6919-0000-0000	CP6919-0001-0000	
12-inch display 800 x 600	CP6911-0000-0000	CP6911-0001-0000	
15-inch display 1024 x 768	CP6912-0000-0000	CP6912-0001-0000	
19-inch display 1280 x 1024	CP6913-0000-0000	CP6913-0001-0000	
Numeric keyboard			
6.5-inch display 640 x 480	CP6929-0000-0000	CP6929-0001-0000	
12-inch display 800 x 600	CP6921-0000-0000	CP6921-0001-0000	CP6921-0002-0000
15-inch display 1024 x 768	CP6922-0000-0000	CP6922-0001-0000	CP6922-0002-0000
19-inch display 1280 x 1024	CP6923-0000-0000	CP6923-0001-0000	CP6923-0002-0000
Alphanumeric keyboard			
12-inch display 800 x 600	CP6931-0000-0000	CP6931-0001-0000	CP6931-0002-0000
15-inch display 1024 x 768	CP6932-0000-0000	CP6932-0001-0000	CP6932-0002-0000
19-inch display 1280 x 1024	CP6933-0000-0000	CP6933-0001-0000	CP6933-0002-0000
Alphanumeric keyboard with PLC keys on the sides			
15-inch display 1024 x 768	CP6942-0000-0000	CP6942-0001-0000	



Without keys

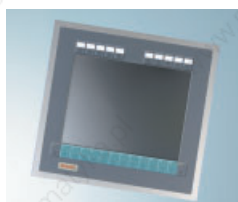

Function keys



Numeric keyboard



Alphanumeric keyboard

Alphanumeric keyboard
with PLC keys on the sides

CP69xx	"Economy" built-in Control Panel	
Features	TFT display in six sizes <ul style="list-style-type: none"> – 5.7-inch display 640 x 480 – 6.5-inch display 640 x 480 – 12-inch display 800 x 600 – 15-inch display 1024 x 768 – 19-inch display 1280 x 1024 – 24-inch display 1920 x 1200 	
	aluminium front with sheet-steel rear cover, front side IP 65, rear side IP 20	
	front laminate in five variants <ul style="list-style-type: none"> – only display – function keys and 10 PLC special keys with LED – numeric keyboard and 10 PLC special keys with LED – alphanumeric PC keyboard in US layout and 10 PLC special keys with LED – alphanumeric PC keyboard in US layout and 16 PLC special keys with LED on the sides 	
	integrated DVI/USB extension technology <ul style="list-style-type: none"> – DVI-E and USB-E enable remote panel operation at a distance of up to 50 m from the PC. – DVI-E input is compatible to the standard DVI output of a PC. 	
	USB input for the direct connection to a standard USB output of a PC with distances of up to 5 m	
	all connectors at the lower rear side	
	24 V power supply	
	operating temperature 0...55 °C	
	pull-out clamping levers for fast installation without loose parts	
	Options	touch screen pen with wall holder
		push-button extension with electromechanical switches and keys
		connecting kits for up to 50 m distance to the PC
		wall mounting frame for building installation
Stainless steel options	stainless steel front (1.4301) with bevelled edges at top and bottom and touch screen for CP690x	
Further information	for further options, technical drawings, documentations, etc. see www.beckhoff.com/CP69xx	



CP79xx | "Economy" Control Panel with DVI/USB Extended interface

Ordering information	without touch screen	with single-touch screen	with touch pad
Display only			
6.5-inch display 640 x 480	CP7909-0000-0000	CP7909-0001-0000	
12-inch display 800 x 600	CP7901-0000-0000	CP7901-0001-0000	
15-inch display 1024 x 768	CP7902-0000-0000	CP7902-0001-0000	
19-inch display 1280 x 1024	CP7903-0000-0000	CP7903-0001-0000	
24-inch display 1920 x 1200	CP7904-0000-0000	CP7904-0001-0000	
Display only, USB A socket in the front			
12-inch display 800 x 600	CP7901-0020-0000	CP7901-0021-0000	
15-inch display 1024 x 768	CP7902-0020-0000	CP7902-0021-0000	
19-inch display 1280 x 1024	CP7903-0020-0000	CP7903-0021-0000	
24-inch display 1920 x 1200	CP7904-0020-0000	CP7904-0021-0000	
With function keys			
6.5-inch display 640 x 480	CP7919-0000-0000	CP7919-0001-0000	
12-inch display 800 x 600	CP7911-0000-0000	CP7911-0001-0000	
15-inch display 1024 x 768	CP7912-0000-0000	CP7912-0001-0000	
19-inch display 1280 x 1024	CP7913-0000-0000	CP7913-0001-0000	
Numeric keyboard			
6.5-inch display 640 x 480	CP7929-0000-0000	CP7929-0001-0000	
12-inch display 800 x 600	CP7921-0000-0000	CP7921-0001-0000	CP7921-0002-0000
15-inch display 1024 x 768	CP7922-0000-0000	CP7922-0001-0000	CP7922-0002-0000
19-inch display 1280 x 1024	CP7923-0000-0000	CP7923-0001-0000	CP7923-0002-0000
Alphanumeric keyboard			
12-inch display 800 x 600	CP7931-0000-0000	CP7931-0001-0000	CP7931-0002-0000
15-inch display 1024 x 768	CP7932-0000-0000	CP7932-0001-0000	CP7932-0002-0000
19-inch display 1280 x 1024	CP7933-0000-0000	CP7933-0001-0000	CP7933-0002-0000
Alphanumeric keyboard with PLC keys on the sides			
15-inch display 1024 x 768	CP7942-0000-0000	CP7942-0001-0000	
Stainless steel housing		with single-touch screen	with single-touch screen, push-buttons and USB socket
12-inch display 800 x 600		CP7901-1400-0000	CP7901-1401-0000
15-inch display 1024 x 768		CP7902-1400-0000	CP7902-1401-0000
19-inch display 1280 x 1024		CP7903-1400-0000	CP7903-1401-0000



Stainless steel finish



Without keys



Function keys



Numeric keyboard



Alphanumeric keyboard

Alphanumeric keyboard
with PLC keys on the sides

CP79xx	"Economy" Control Panel	
Features	TFT display in five sizes <ul style="list-style-type: none"> – 6.5-inch display 640 x 480 – 12-inch display 800 x 600 – 15-inch display 1024 x 768 – 19-inch display 1280 x 1024 – 24-inch display 1920 x 1200 	
	aluminium housing, protection class IP 65	
	front laminate in five variants <ul style="list-style-type: none"> – only display – function keys and 10 PLC special keys with LED – numeric keyboard and 10 PLC special keys with LED – alphanumeric PC keyboard in US layout and 10 PLC special keys with LED – alphanumeric PC keyboard in US layout and 16 PLC special keys with LED on the sides 	
	special keys identified by slide-in labels	
	integrated DVI/USB extension technology <ul style="list-style-type: none"> – DVI-E and USB-E enable remote panel operation at a distance of up to 50 m from the PC. – DVI-E input is compatible to the standard DVI output of a PC. 	
	connection via 3 round connectors (IP 65) for DVI, USB-E and 24 V power supply unit in the backplane	
	operating temperature 0...55 °C	
	for mounting 4 M6 x 18 mm threaded holes in the backplane	
	Options	2-port IP 65 USB interface in the backplane
		touch screen pen with holder for aluminium Control Panels
additional keyboard IP 65 or toolboard for keyboard and tools		
push-button extension with electromechanical switches and keys		
connection set up to 50 m length		
Stainless steel options	adapter plate for mounting arm installation	
	stainless steel housing with flush-mounted touch screen for CP7901, CP7902 and CP7903	
Further information	for further options, technical drawings, documentations, etc. see www.beckhoff.com/CP79xx	

Accessories for CP6xxx and CP7xxx single-touch Control Panels and Panel PCs

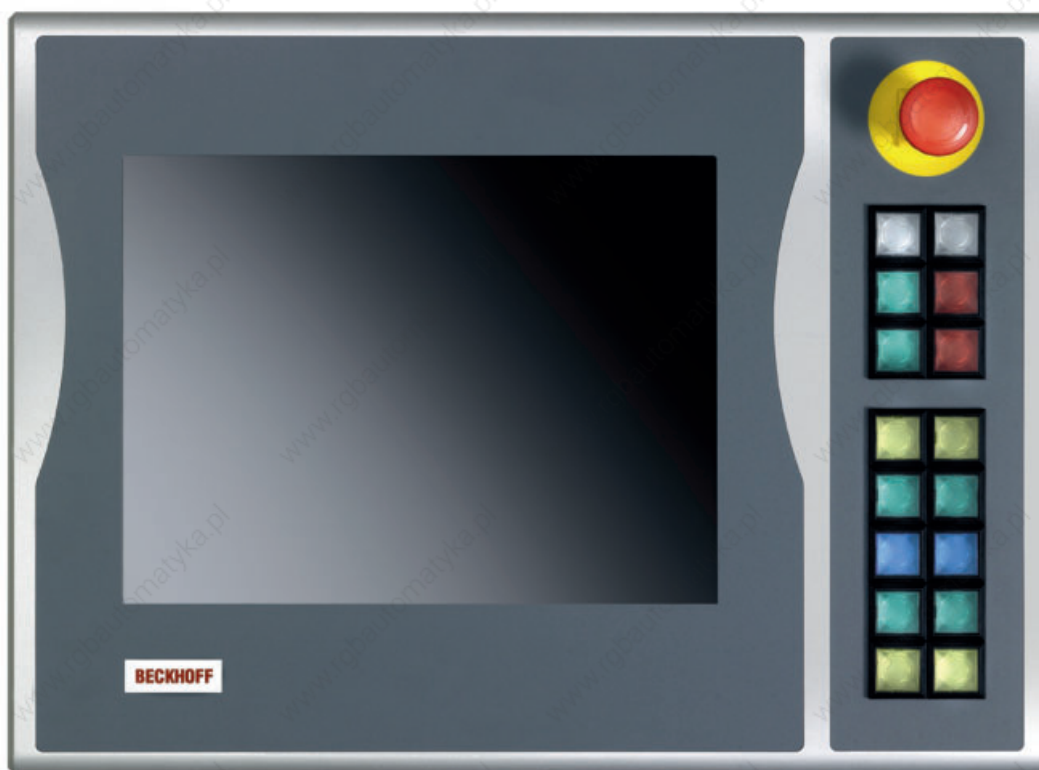



C9900-M400 | Keyboard shelf
for Control Panels and Panel PCs



C9900-T90x | Touch screen pen
for Control Panels and Panel PCs



K7xxx, KT7xxx | Additional keyboard
for Control Panels and Panel PCs



C9900-E21x | RFID reader
in the Control Panel front

Electromechanical buttons on the Control Panel

Control Panels and Panel PCs with push-button extension enable the application-specific arrangement of electromechanical buttons, switches, signal lamps, additional membrane keys and a hand wheel directly on the operating unit. It enables precise adaptation of the Control Panel to the machine control requirements. In many cases, a machine operator control panel is no longer required, since all functions are integrated in the Control Panel. The Control Panel housing is increased in size on one side. Depending on the required functions and the electromechanical components, the flat rear panel is enlarged or extended with a trough-shaped rear panel for the button area.

For the CP77xx and CP79xx units the Rolec Tara Plus mounting arm system, article numbers 149.025.012, 149.025.013, 149.025.014, 149.035.012, 149.035.013 or 149.035.015, can be mounted centrally at the rear of the Control Panel. The mounting

arm can optionally be connected from above or below. The Rittal mounting arm system is available as an additional option. The CP6508.020 or CP6501.170 Rittal adapters can be mounted at the back of the Control Panel. The cables are routed through the mounting arm, through a cable gland in the mounting arm adapter and from there concealed through a channel at the rear of the Control Panel to the push-button extension. The housings of the CP7xxx range have protection class IP 65 on all sides. The wiring space can be opened without removing the Control Panel from the mounting arm. The buttons, switches and indicator lamps are connected to the control system via USB. A second contact on the buttons and switches can at the same time be wired directly via a terminal row. Besides the push-button extensions shown on the following pages, numerous other variants are conceivable, which can be individually designed in accordance with requirements.





The photo presents an application-specific push-button configuration.

C9900-Ex0x | Push-button extension for CP6xxx and CP7xxx Control Panels and Panel PCs with 12-inch display and numeric keyboard

C9900-Ex0x	
Features	push-button extension for CP6x21-00xx and CP7x21-00xx
	push-button extension on the right side
	12 push-button keys with signal lamp, type Siemens Signum square, 30 x 30 mm
	1 emergency stop key Siemens Signum, directly wireable
	Labels for push-button caps allow individual marking.
	All push-buttons are transmitted via USB with one normally-open contact.
Dimensions	Additionally, all push-buttons are directly wireable with a second normally-open contact via a terminal row.
	All signal lamps are transmitted via USB only.
	www.beckhoff.com/C9900-Ex0x

Panel PC			ordering no.	additional ordering option	
– 12-inch display – numeric keyboard	built-in	CP6221 Economy	50	C9900-E505	–
		CP6521	60	C9900-E705	–
	mounting arm	CP7121	64	C9900-E506	–
		CP7221 Economy	68	C9900-E507	–
		CP7721	72	C9900-E808*	mounting arm system Rittal instead of Rolec: C9900-M405
	without mounting arm	CP7721	72	C9900-E801	screwed cable gland: C9900-M931

Control Panel			ordering no.	additional ordering option	
– 12-inch display – numeric keyboard	built-in	CP6621 Economy	154	C9900-E406	–
		CP6921 Economy	158	C9900-E905	–
	mounting arm	CP7921 Economy	160	C9900-E708*	mounting arm system Rittal instead of Rolec: C9900-M205
	without mounting arm	CP7921 Economy	160	C9900-E701	screwed cable gland: C9900-M931

* Circular plug-in connector instead of screwed cable gland on request



The photo presents an application-specific push-button configuration.

C9900-Ex1x | Push-button extension for CP6xxx and CP7xxx Control Panels and Panel PCs with 12-inch display and alphanumeric keyboard

C9900-Ex1x	
Features	push-button extension for CP6x31-00xx and CP7x31-00xx
	push-button extension on the right side
	16 push-button keys with signal lamp, type Siemens Signum square, 30 x 30 mm
	1 emergency stop key Siemens Signum, directly wireable
	Labels for push-button caps allow individual marking.
	All push-buttons are transmitted via USB with one normally-open contact.
	Additionally, all push-buttons are directly wireable with a second normally-open contact via a terminal row.
Dimensions	All signal lamps are transmitted via USB only.
	www.beckhoff.com/C9900-Ex1x

Panel PC			ordering no.	additional ordering option	
– 12-inch display – alphanumeric keyboard	built-in	CP6231 Economy	50	C9900-E515	–
		CP6531	60	C9900-E715	–
	mounting arm	CP7131	64	C9900-E516	–
		CP7231 Economy	68	C9900-E517	–
		CP7731	72	C9900-E818*	mounting arm system Rittal instead of Rolec: C9900-M405
		CP7731	72	C9900-E811	screwed cable gland: C9900-M931
	without mounting arm				

Control Panel			ordering no.	additional ordering option	
– 12-inch display – alphanumeric keyboard	built-in	CP6631 Economy	154	C9900-E416	–
		CP6931 Economy	158	C9900-E915	–
	mounting arm	CP7931 Economy	160	C9900-E718*	mounting arm system Rittal instead of Rolec: C9900-M205
	without mounting arm	CP7931 Economy	160	C9900-E711	screwed cable gland: C9900-M931

* Circular plug-in connector instead of screwed cable gland on request



C9900-Ex4x | Push-button extension for CP6xxx and CP7xxx Control Panels and Panel PCs with 15-inch display without keyboard

C9900-Ex4x	
Features	push-button extension for CP6x02-00xx and CP7x02-00xx
	push-button extension on the right side
	16 push-button keys with signal lamp, type Siemens Signum square, 30 x 30 mm
	1 emergency stop key Siemens Signum, directly wireable
	Labels for push-button caps allow individual marking.
	All push-buttons are transmitted via USB with one normally-open contact.
Dimensions	Additionally, all push-buttons are directly wireable with a second normally-open contact via a terminal row.
	All signal lamps are transmitted via USB only.
	www.beckhoff.com/C9900-Ex4x

Panel PC			ordering no.	additional ordering option	
– 15-inch display – without keyboard	built-in	CP6202 Economy	50	C9900-E545	–
		CP6502	60	C9900-E745	–
	mounting arm	CP7102	64	C9900-E546	–
		CP7202 Economy	68	C9900-E547	–
		CP7702	72	C9900-E848*	mounting arm system Rittal instead of Rolec: C9900-M405
	without mounting arm	CP7702	72	C9900-E841	screwed cable gland: C9900-M931

Control Panel			ordering no.	additional ordering option	
– 15-inch display – without keyboard	built-in	CP6602 Economy	154	C9900-E446	–
		CP6902 Economy	158	C9900-E945	–
	mounting arm	CP7902 Economy	160	C9900-E748*	mounting arm system Rittal instead of Rolec: C9900-M205
		CP7902 Economy	160	C9900-E741	screwed cable gland: C9900-M931
	without mounting arm				

* Circular plug-in connector instead of screwed cable gland on request



C9900-Ex5x | Push-button extension for CP6xxx and CP7xxx Control Panels and Panel PCs with 15-inch display and function keys

C9900-Ex5x	
Features	push-button extension for CP6x12-00xx and CP7x12-00xx
	push-button extension on the right side
	16 push-button keys with signal lamp, type Siemens Signum square, 30 x 30 mm
	1 emergency stop key Siemens Signum, directly wireable
	Labels for push-button caps allow individual marking.
	All push-buttons are transmitted via USB with one normally-open contact.
	Additionally, all push-buttons are directly wireable with a second normally-open contact via a terminal row.
Dimensions	All signal lamps are transmitted via USB only.
	www.beckhoff.com/C9900-Ex5x

Panel PC			ordering no.	additional ordering option	
– 15-inch display – function keys	built-in	CP6212 Economy	50	C9900-E555	–
		CP6512	60	C9900-E755	–
	mounting arm	CP7112	64	C9900-E556	–
		CP7212 Economy	68	C9900-E557	–
		CP7712	72	C9900-E858*	mounting arm system Rittal instead of Rolec: C9900-M405
	without mounting arm	CP7712	72	C9900-E851	screwed cable gland: C9900-M931

Control Panel			ordering no.	additional ordering option	
– 15-inch display – function keys	built-in	CP6612 Economy	154	C9900-E456	–
		CP6912 Economy	158	C9900-E955	–
	mounting arm	CP7912 Economy	160	C9900-E758*	mounting arm system Rittal instead of Rolec: C9900-M205
	without mounting arm	CP7912 Economy	160	C9900-E751	screwed cable gland: C9900-M931

* Circular plug-in connector instead of screwed cable gland on request



C9900-Ex6x | Push-button extension for CP6xxx and CP7xxx Control Panels and Panel PCs with 15-inch display and numeric keyboard

C9900-Ex6x	
Features	push-button extension for CP6x22-00xx and CP7x22-00xx
	push-button extension on the right side
	14 push-button keys with signal lamp, type Siemens Signum square, 30 x 30 mm
	1 emergency stop key Siemens Signum, directly wireable
	Labels for push-button caps allow individual marking.
	All push-buttons are transmitted via USB with one normally-open contact.
Dimensions	Additionally, all push-buttons are directly wireable with a second normally-open contact via a terminal row.
	All signal lamps are transmitted via USB only.
	www.beckhoff.com/C9900-Ex6x

Panel PC			ordering no.	additional ordering option	
– 15-inch display – numeric keyboard	built-in	CP6222 Economy	50	C9900-E565	–
		CP6522	60	C9900-E765	–
	mounting arm	CP7122	64	C9900-E566	–
		CP7222 Economy	68	C9900-E567	–
		CP7722	72	C9900-E868*	mounting arm system Rittal instead of Rolec: C9900-M405
	without mounting arm	CP7722	72	C9900-E861	screwed cable gland: C9900-M931

Control Panel			ordering no.	additional ordering option	
– 15-inch display – numeric keyboard	built-in	CP6622 Economy	154	C9900-E466	–
		CP6922 Economy	158	C9900-E965	–
	mounting arm	CP7922 Economy	160	C9900-E768*	mounting arm system Rittal instead of Rolec: C9900-M205
	without mounting arm	CP7922 Economy	160	C9900-E761	screwed cable gland: C9900-M931

* Circular plug-in connector instead of screwed cable gland on request



C9900-Ex7x | Push-button extension for CP6xxx and CP7xxx Control Panels and Panel PCs with 15-inch display and alphanumeric keyboard

C9900-Ex7x	
Features	push-button extension for CP6x32-00xx and CP7x32-00xx
	push-button extension on the right side
	18 push-button keys with signal lamp, type Siemens Signum square, 30 x 30 mm
	1 emergency stop key Siemens Signum, directly wireable
	Labels for push-button caps allow individual marking.
	All push-buttons are transmitted via USB with one normally-open contact.
	Additionally, all push-buttons are directly wireable with a second normally-open contact via a terminal row.
Dimensions	All signal lamps are transmitted via USB only.
	www.beckhoff.com/C9900-Ex7x

Panel PC			ordering no.	additional ordering option	
– 15-inch display – alphanumeric keyboard	built-in	CP6232 Economy	50	C9900-E575	–
		CP6532	60	C9900-E775	–
	mounting arm	CP7132	64	C9900-E576	–
		CP7232 Economy	68	C9900-E577	–
		CP7732	72	C9900-E878*	mounting arm system Rittal instead of Rolec: C9900-M405
		CP7732	72	C9900-E871	screwed cable gland: C9900-M931
	without mounting arm				

Control Panel			ordering no.	additional ordering option	
– 15-inch display – alphanumeric keyboard	built-in	CP6632 Economy	154	C9900-E476	–
		CP6932 Economy	158	C9900-E975	–
	mounting arm	CP7932 Economy	160	C9900-E778*	mounting arm system Rittal instead of Rolec: C9900-M205
	without mounting arm	CP7932 Economy	160	C9900-E771	screwed cable gland: C9900-M931

* Circular plug-in connector instead of screwed cable gland on request



C9900-Ex2x | Push-button extension for CP6xxx and CP7xxx Control Panels and Panel PCs with 19-inch display without keyboard

C9900-Ex2x	
Features	push-button extension for CP6x03-00xx and CP7x03-00xx
	push-button extension on the right side
	20 push-button keys with signal lamp, type Siemens Signum square, 30 x 30 mm
	1 emergency stop key Siemens Signum, directly wireable
	Labels for push-button caps allow individual marking.
	All push-buttons are transmitted via USB with one normally-open contact.
	Additionally, all push-buttons are directly wireable with a second normally-open contact via a terminal row.
Dimensions	All indicator lights are controlled exclusively via USB.
	www.beckhoff.com/C9900-Ex2x

Panel PC			ordering no.	additional ordering option	
– 19-inch display – without keyboard	built-in	CP6203 Economy	50	C9900-E525	–
		CP6503	60	C9900-E725	–
	mounting arm	CP7103	64	C9900-E526	–
		CP7203 Economy	68	C9900-E527	–
		CP7703	72	C9900-E828*	mounting arm system Rittal instead of Rolec: C9900-M405
	without mounting arm	CP7703	72	C9900-E823	screwed cable gland: C9900-M931

Control Panel			ordering no.	additional ordering option	
– 19-inch display – without keyboard	built-in	CP6903 Economy	158	C9900-E925	–
		CP7903 Economy	160	C9900-E728*	mounting arm system Rittal instead of Rolec: C9900-M205
	without mounting arm	CP7903 Economy	160	C9900-E723	screwed cable gland: C9900-M931

* Circular plug-in connector instead of screwed cable gland on request



C9900-Ex3x | Push-button extension for CP6xxx and CP7xxx Control Panels and Panel PCs with 19-inch display and function keys

C9900-Ex3x	
Features	push-button extension for CP6x13-00xx and CP7x13-00xx
	push-button extension on the right side
	20 push-button keys with signal lamp, type Siemens Signum square, 30 x 30 mm
	1 emergency stop key Siemens Signum, directly wireable
	Labels for push-button caps allow individual marking.
	All push-buttons are transmitted via USB with one normally-open contact.
	Additionally, all push-buttons are directly wireable with a second normally-open contact via a terminal row.
Dimensions	All signal lamps are transmitted via USB only.
	www.beckhoff.com/C9900-Ex3x

Panel PC				ordering no.	additional ordering option
– 19-inch display – function keys	built-in	CP6213 Economy	50	C9900-E535	–
		CP6513	60	C9900-E735	–
	mounting arm	CP7113	64	C9900-E536	–
		CP7213 Economy	68	C9900-E537	–
		CP7713	72	C9900-E838*	mounting arm system Rittal instead of Rolec: C9900-M405
	without mounting arm	CP7713	72	C9900-E831	screwed cable gland: C9900-M931

Control Panel				ordering no.	additional ordering option
– 19-inch display – function keys	built-in	CP6913 Economy	158	C9900-E935	–
	mounting arm	CP7913 Economy	160	C9900-E738*	mounting arm system Rittal instead of Rolec: C9900-M205
	without mounting arm	CP7913 Economy	160	C9900-E731	screwed cable gland: C9900-M931

* Circular plug-in connector instead of screwed cable gland on request



C9900-Ex9x | Push-button extension for CP6xxx and CP7xxx Control Panels and Panel PCs with 19-inch display and numeric keyboard

C9900-Ex9x	
Features	push-button extension for CP6x23-00xx and CP7x23-00xx
	push-button extension on the right side
	20 push-button keys with signal lamp, type Siemens Signum square, 30 x 30 mm
	1 emergency stop key Siemens Signum, directly wireable
	Labels for push-button caps allow individual marking.
	All push-buttons are transmitted via USB with one normally-open contact.
	Additionally, all push-buttons are directly wireable with a second normally-open contact via a terminal row.
Dimensions	All signal lamps are transmitted via USB only.
	www.beckhoff.com/C9900-Ex9x-n

Panel PC			ordering no.	additional ordering option	
– 19-inch display	built-in	CP6223 Economy	50	C9900-E594	–
		CP6523	60	C9900-E796	–
– numeric keyboard	mounting arm	CP7123	64	C9900-E596	–
		CP7223 Economy	68	C9900-E597	–
		CP7723	72	C9900-E898*	mounting arm system Rittal instead of Rolec: C9900-M405
		CP7723	72	C9900-E892	screwed cable gland: C9900-M931
	without mounting arm				

Control Panel			ordering no.	additional ordering option	
– 19-inch display	built-in	CP6923 Economy	158	C9900-E996	–
		CP7923 Economy	160	C9900-E798*	mounting arm system Rittal instead of Rolec: C9900-M205
– numeric keyboard	without mounting arm	CP7923 Economy	160	C9900-E792	screwed cable gland: C9900-M931

* Circular plug-in connector instead of screwed cable gland on request



C9900-Ex9x | Push-button extension for CP6xxx and CP7xxx Control Panels and Panel PCs with 19-inch display and alphanumeric keyboard

C9900-Ex9x	
Features	push-button extension for CP6x33-00xx and CP7x33-00xx
	push-button extension on the right side
	20 push-button keys with signal lamp, type Siemens Signum square, 30 x 30 mm
	1 emergency stop key Siemens Signum, directly wireable
	Labels for push-button caps allow individual marking.
	All push-buttons are transmitted via USB with one normally-open contact.
	Additionally, all push-buttons are directly wireable with a second normally-open contact via a terminal row.
Dimensions	All signal lamps are transmitted via USB only.
	www.beckhoff.com/C9900-Ex9x-a

Panel PC				ordering no.	additional ordering option
– 19-inch display – alphanumeric keyboard	built-in	CP6233 Economy	50	C9900-E595	–
		CP6533	60	C9900-E797	–
	mounting arm	CP7133	64	C9900-E598	–
		CP7233 Economy	68	C9900-E599	–
		CP7733	72	C9900-E899*	mounting arm system Rittal instead of Rolec: C9900-M405
		CP7733	72	C9900-E893	screwed cable gland: C9900-M931
	without mounting arm	CP7733	72	C9900-E893	screwed cable gland: C9900-M931

Control Panel				ordering no.	additional ordering option
– 19-inch display – alphanumeric keyboard	built-in	CP6933 Economy	158	C9900-E997	–
		CP7933 Economy	160	C9900-E799*	mounting arm system Rittal instead of Rolec: C9900-M205
	without mounting arm	CP7933 Economy	160	C9900-E793	screwed cable gland: C9900-M931

* Circular plug-in connector instead of screwed cable gland on request



C9900-E78x | PLC push-button extension for tool machines at CP6xxx and CP7xxx Control Panels and Panel PCs

C9900-E78x	
Features	PLC push-button extension for tool machines at Control Panel CP6942, CP7942 and Panel PC CP6242, CP6542, CP7142 and CP7242 push-button extension below 16 push-button keys with signal lamp, type Siemens Signum square, 30 x 30 mm 1 emergency stop key Siemens Signum, directly wireable Labels for push-button caps allow individual marking. push-button status readable via USB Additionally, all push-buttons are directly wireable with a second normally-open contact via a terminal row. All indicator lights are controlled exclusively via USB. 1 graycode switch with 23 positions, controlled via USB 2-port USB A interface in the front with screw cap IP 65
Dimensions	www.beckhoff.com/C9900-E78x-PLC

Panel PC			ordering no.	additional ordering option
built-in	CP6242 Economy	50	C9900-E781*	–
	CP6542	60	C9900-E780*	–
mounting arm from top/bottom	CP7142	64	C9900-E782*	–
	CP7242 Economy	68	C9900-E784	–

Control Panel			ordering no.	additional ordering option
built-in	CP6942 Economy	158	C9900-E781*	–
	CP7942 Economy	160	C9900-E783*	mounting arm system Rittal instead of Rolec: C9900-M205* mounting arm system Rose instead of Rolec: – mounting arm from top: C9900-M203 – mounting arm from bottom: C9900-M204

* Circular plug-in connector instead of screwed cable gland on request



C9900-E78x | CNC push-button extension for tool machines at CP6xxx and CP7xxx Control Panels and Panel PCs

C9900-E78x	
Features	CNC push-button extension for tool machines at Control Panel CP6942, CP7942 and Panel PC CP6242, CP6542, CP7142 and CP7242 push-button extension below 2 push-button keys with signal lamp, type Siemens Signum round, directly wireable 1 emergency stop key Siemens Signum, directly wireable 1 key switch, type Siemens Signum round, directly wireable 45 membrane keys with a LED in each key, controlled via USB inscription of the keys via slide-in labels 1 graycode switch with 17 positions, controlled via USB 1 graycode switch with 23 positions, controlled via USB
Dimensions	www.beckhoff.com/C9900-E78x-CNC

Panel PC			ordering no.	additional ordering option
built-in	CP6242 Economy	50	C9900-E787	–
	CP6542	60	C9900-E786	–
mounting arm from top/bottom	CP7142	64	C9900-E788	connection for control unit: C9900-E181
	CP7242 Economy	68	C9900-E791	connection for control unit: C9900-E181

Control Panel			ordering no.	additional ordering option
built-in	CP6942 Economy	158	C9900-E787	–
	CP7942 Economy	160	C9900-E789	connection for control unit: C9900-E181
mounting arm from top/bottom				mounting arm system Rittal instead of Rolec: C9900-M206
				mounting arm system Rose instead of Rolec:
				– mounting arm from top: C9900-M203 – mounting arm from bottom: C9900-M204

K7xxx, KT7xxx | Additional keyboard for CP7xxx Control Panels and Panel PCs

The indestructible PC keyboard

The K7xxx and KT7xxx PC keyboards add a keyboard to the Control Panel which allows the comfortable entry of large amounts of data with a keyboard designed for industrial use. The Control Panel keyboards K7xxx and KT7xxx are even more robust than a membrane keyboard and yet feel almost like a standard keyboard. They offer the optimum in operating comfort in tough industrial environments.

An aluminium keyboard housing in Control Panel design combines the keyboard and the Control Panel to form a homogeneous unit. The width of the housing is adapted to the Control Panel for which the keyboard is intended.

A touch pad can be integrated into the keyboard housing. Here, large, easily accessible keys meeting protection class IP 67 serve as mouse keys. The keyboards K7xxx and KT7xxx are mounted in a holder on the Control Panel which is available in a version located at a fixed angle of 100° and a version which can be adjusted between 90° and 180°. The Control Panel is modified to have additional open sections in the side contour which allow the cabling to be stored in an invisible way.



Ordering information	
K7100-0000	additional keyboard to be mounted to a Control Panel CP79xx or to a Panel PC CP71xx, CP72xx and CP77xx
KT7100-0000	additional keyboard with touch pad to be mounted to a Control Panel CP79xx or to a Panel PC CP71xx, CP72xx and CP77xx
C9900-M300	mounting adapter with fixed 100° angle for mounting a keyboard K7xxx or KT7xxx to a Control Panel
C9900-M310	mounting adapter with adjustable 90° to 180° angle for mounting a keyboard K7xxx or KT7xxx to a Control Panel

C9900-M400 | Keyboard shelf for CP7xxx Control Panels and Panel PCs

The keyboard shelf at a Beckhoff Control Panel permits a standard PC keyboard to be placed in front of the Control Panel, allowing convenient operation during commissioning or software updates. During normal production, the machine operator can rest tools and other items here while using the Control Panel.

The shelf is constructed from anodised aluminium. Its design matches that of the Control Panel. A ribbed rubber mat is glued to the surface of the shelf. The keyboard shelf is made as wide as the Control Panel. In the case of small Control Panels, the shelf is wider than the Control Panel housing, so that a keyboard can be rested on it. The Control Panel is given additional holes on the lower side, so the shelf should be ordered at the same time as the Control Panel.



Ordering information	
C9900-M400	toolboard for keyboard or tools, mounted under a Control Panel CP7xxx or Panel PCs CP7xxx
C9900-M401	drill holes at the bottom of a Control Panel or Panel PC CP7xxx for assembly of a keyboard shelf (supply without shelf)

C9900-T90x | Touch screen pen for CP6xxx, CP7xxx and C3xxx Control Panels and Panel PCs

The Beckhoff touch screen pen enables touch screen technology to be used in harsh areas of application and offers higher operating precision than fingers or other pointing media. Shavings and dirt are no longer an obstacle: even wearing gloves the operator can make precise entries, since the robust, spherical tip of the pen enables easy and smooth operation while at the same time improving visibility of the display. Direct operation (without pen) is still possible, although the plastic tip of the pen protects the surface of the touch screen. The user of the Beckhoff touch screen pen receives an extremely precise input medium with an ergonomically formed, non-slip aluminium shaft, in a design which conforms to that of the Control Panel, and with the right balance of weight, form and friction. The pen is also suitable for built-in Panel PCs with touch screen.



Ordering information	
C9900-T900	touch screen pen with holder for Control Panel and Panel PCs CP7xxx
C9900-T902	touch screen pen with wall holder for built-in Control Panel and Panel PCs CP6xxx and C3xxx

C9900-E21x | RFID reader in the CP7xxx Control Panel front

The CP710x, CP720x and CP770x Panel PCs and the CP790x Control Panels with 15- or 19-inch display without membrane keyboard are available with RFID reader in the front panel. The card reader enables user identification at the device. The RFID module reads Legic transponders at a distance of up to 30 mm. The data are transferred to the PC via USB. The RFID reader is integrated in the Control Panel or the Panel PC behind the front laminate. The print on the front laminate indicates the position of the RFID reader below the display on the right-hand side. IP 65 protection class is maintained and enables operation in harsh industrial environments. The RFID option has no influence on the dimensions of the Control Panel.



C9900-E21x	RFID reader
	Legic transponder type
	transponder frequency 13.56 MHz
	integrated in the Control Panel behind the front laminate
	up to 30 mm reading distance
	internally connected via USB interface
	protection class IP 65

Ordering information	
C9900-E213	RFID reader for Legic transponder inside the front of a Panel PC CP7102, CP7202 or CP7702 or of a Control Panel CP7902, integrated behind the front laminate, protection class IP 65, connected internally by USB
C9900-E214	RFID reader for Legic transponder inside the front of a Panel PC CP7103, CP7203 or CP7703 or of a Control Panel CP7903, integrated behind the front laminate, protection class IP 65, connected internally by USB