



HEIDENHAIN

HEIDENHAIN Motors

for Axis and Spindle Drives

Information for the
Machine Tool Builder

July 2013



Synchronous motors for feed drives

Motors for axis and spindle drives

HEIDENHAIN supplies motors for axis and spindle drives as accessories to its controls with integrated inverter.

This brochure provides an overview of all the available motors and contains technical data and mating dimensions.

For commissioning, please request the *Inverter Systems and Motors* Technical Manual.

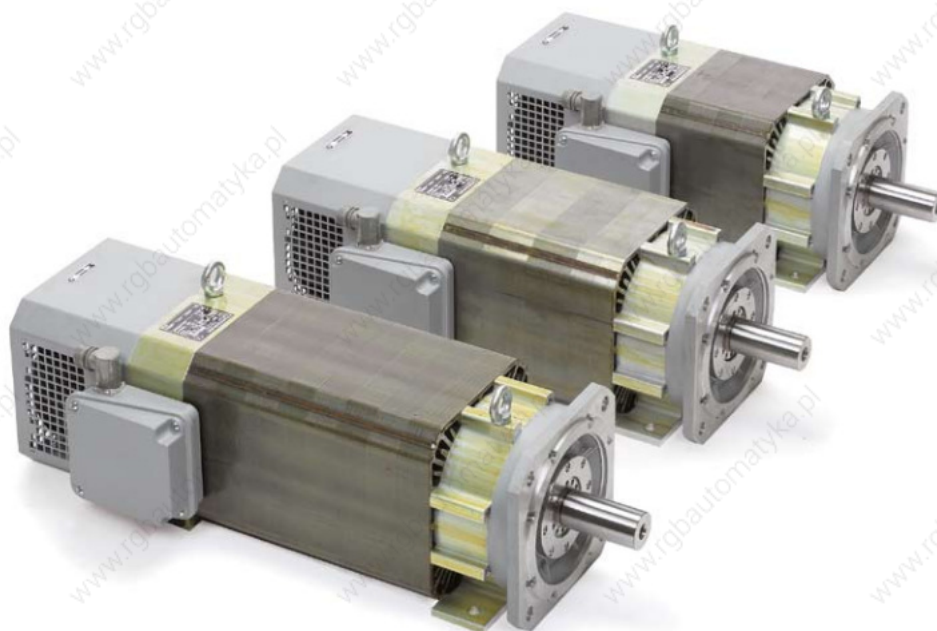

Asynchronous motors for spindles

This catalog supersedes all previous editions, which thereby become invalid. The basis for ordering from HEIDENHAIN is always the catalog edition valid when the contract is made.

Standards (ISO, EN, etc.) apply only where explicitly stated in the catalog.

Expendable parts

HEIDENHAIN motors contain components that are subject to wear, depending on the application and handling. These include in particular the following parts:

- s Bearings
- s Brakes
- s Shaft sealing rings
- s Fan

Contents

Synchronous motors	Overview QSY		4
	Specifications	Series QSY 55	6
		Series QSY 96	8
		Series QSY 116 QSY 116 EcoDyn	10
		Series QSY 130 EcoDyn	12
		Series QSY 155	14
		Series QSY 155 EcoDyn	16
		Series QSY 190 EcoDyn	18
		Torque characteristics QSY	
	Cables and connectors		23
Asynchronous motors	Overview QAN		24
	Specifications	Series QAN 200	26
		Series QAN 260	28
		Series QAN 320	30
		Series QAN 200UH	32
		Series QAN 260xH	34
	Power and torque characteristics QAN		36
Cables and connectors		42	
Accessories	Toroidal cores		43

Synchronous motors

QSY overview

General technical information

Synchronous motors from HEIDENHAIN fulfill all requirements of a numerically controlled machine tool. Some special characteristics include

- s an excellent running smoothness,
- s an appropriate mass moment of inertia,
- s a very good ratio of the rated torque to the stall torque,
- s and a low torque ripple.

Specifications

The specifications and the characteristic curves apply to motors mounted without thermal insulation. The temperature of the winding may differ from the maximum permissible ambient temperature of 40 °C by a maximum of 100 K. If the motor is mounted so that it is thermally insulated, it is necessary to reduce the motor torque in order to avoid thermal overloading of the motor.

For motors with ECN 1313 or EQN 1325 absolute rotary encoders, the rated torque is reduced by 10 %.

Speed measurement

Synchronous motors from HEIDENHAIN operate with sinusoidal commutation. An integrated rotary encoder from HEIDENHAIN measures the rotor position and shaft speed. The following versions are available (see *Specifications*):

- s ERN 1387 incremental rotary encoder or
- s ECN 1313 absolute singleturn rotary encoder (only one motor revolution can be evaluated) or
- s EQN 1325 absolute multiturn rotary encoder

Mechanical life

The service life of the bearings depends on the shaft load and the average shaft speed (see the *Inverter Systems and Motors Technical Manual*).

The nominal bearing service life—which depends on the specific motor and applies for a certain maximum shaft load at an average shaft speed—is 30 000 hours for QSY motors.

EcoDyn motors

Motors of the EcoDyn series are characterized by reduced current consumption together with higher rated torque and a max. permissible rated speed of 3000 min⁻¹. The following controls are required in order to drive the motors in EcoDyn mode:

- s iTNC 530 as of software 340420-06
- s iTNC 530 HSCI
- s TNC 640
- s TNC 620
- s MANUALplus 620
- s CNC PILOT 4290 as of software 340460-14 and 362796-10

For all other controls, the rated speed is 2000 min⁻¹.

Electronic ID label

The synchronous motors with ECN 1313 or EQN 1325 feature an electronic ID label to make commissioning and diagnosis easier. The information, such as motor designation, ID number or serial number, stored in this ID label can be read and displayed by the TNCdiag diagnostic software as well as by the internal diagnostic functions of the iTNC 530 (as of software 340422-07 and 340480-07).

The control automatically identifies the motor type and, if required, updates the machine parameters every time it is switched on.

Mechanical data

Design IM B5 (mounting via flange) according to EN 60034-7

Mounting of the motor

The following screws are recommended for securing the motor:

QSY 55	M5
QSY 96	M6
QSY 116	M8
QSY 130	M8
QSY 155	M10
QSY 190	M12 x 40

DIN EN ISO 4017

Flange: Dimensions as per DIN 42 948 and IEC 72

Protection as per EN 60 529

Motor: IP 65

Shaft exit: IP 64

Suitability with regard to gear drive

Only for enclosed gear drives. The shaft is suitable only for dry connection.

Vibration severity

Grade N as per IEC 60034-14

Radial runout, concentricity and axial runout

Tolerance N as per IEC 60072-1 (DIN 42955)

Shaft end

Cylindrical **without keyway** as per IEC 72-1 and DIN 748-1 with centering hole as per ISO 866 BS 5 and thread

Upon request:

Shaft **with keyway** and feather key as per DIN 6885-1

s QSY 55: A 3 x 3 x 15

s QSY 96: A 6 x 6 x 32

s QSY 116: A 8 x 7 x 40

s QSY 130: A 8 x 7 x 40

s QSY 155: A 10 x 8 x 50

s QSY 190: A 10 x 8 x 70

The motors with feather key are flush feather-key balanced as per DIN 6885-1.

Bearings free of maintenance

Holding brake as option

Low backlash $\leq 1^\circ$

Thermal specifications

Natural cooling

Temperature monitoring with KTY 84-130 thermistor in the stator winding

Thermal class F

Synchronous motors	Stall torque	Stall current	Rated speed	Recommended inverters ²⁾				Page
				1-axis module	2-axis module	Compact inverters/axis		
						UR 2xxD UE 2xxB	UE 1xx	
QSY 55C	0.4 Nm	1.6 A	6000 min ⁻¹	UM 111 D	UM 121 D	1 to 4	1 to 4	6
QSY 96A	1.5 Nm	1.5 A	4500 min ⁻¹	UM 111 D	UM 121 D	1 to 4	1 to 4	8
QSY 96G	5.2 Nm	5.2 A	4500 min ⁻¹	UM 111 D	UM 121 D	1 to 4	1 to 4	
QSY 116C	5.2 Nm	3.3 A	3000 min ⁻¹	UM 111 D	UM 121 D	1 to 4	1 to 4	
QSY 116E	7.2 Nm	4.8 A	3000 min ⁻¹	UM 111 D	UM 121 D	1 to 4	4	10
QSY 116J	10.0 Nm	6.8 A	3000 min ⁻¹	UM 111 D	UM 121 D	1 to 4	4	
QSY 116J EcoDyn	10.0 Nm	5.0 A	3000 min ⁻¹	UM 111 D	UM 121 D	1 to 4	4	
QSY 130C EcoDyn	6.0 Nm	3.0 A	3000 min ⁻¹	UM 111 D	UM 121 D	1 to 4	1 to 4	
QSY 130E EcoDyn	9.0 Nm	4.5 A	3000 min ⁻¹	UM 111 D	UM 121 D	1 to 4	1 to 4	12
QSY 155B	13.0 Nm	9.1 A	3000 min ⁻¹	UM 111 BD	UM 121 BD	4	–	14
QSY 155C	17.7 Nm	11.8 A	3000 min ⁻¹	UM 111 BD	UM 121 BD	4	–	
QSY 155D	21.6 Nm	14.6 A	3000 min ⁻¹	UM 111 BD	UM 121 BD	4	–	
QSY 155F	26.1 Nm	18.0 A	3000 min ⁻¹	UM 112 D	UM 122 D	4 ¹⁾	–	
QSY 155B EcoDyn	13.0 Nm	6.5 A	3000 min ⁻¹	UM 111 D	UM 121 D	1 to 4	–	16
QSY 155C EcoDyn	17.7 Nm	8.5 A	3000 min ⁻¹	UM 111 BD	UM 121 BD	4	–	
QSY 155D EcoDyn	21.6 Nm	10.6 A	3000 min ⁻¹	UM 111 BD	UM 121 BD	4	–	
QSY 155F EcoDyn	26.1 Nm	12.8 A	3000 min ⁻¹	UM 111 BD	UM 121 BD	4	–	
QSY 190C EcoDyn	28.0 Nm	14.0 A	3000 min ⁻¹	UM 111 BD	UM 121 BD	4	–	18
QSY 190D EcoDyn	38.0 Nm	18.1 A	3000 min ⁻¹	UM 112 D	UM 122 D	4 ¹⁾	–	
QSY 190F EcoDyn	47.6 Nm	22.7 A	3000 min ⁻¹	UM 112 D	UM 122 D	4 ¹⁾	–	
QSY 190K EcoDyn	62.5 Nm	29.8 A	3000 min ⁻¹	UM 113 D	–	–	–	

¹⁾ Only UE 242 B, UR 242 D

²⁾ The maximum acceleration of the motor might not be achievable with the recommended inverters. If necessary, a more powerful power module must be selected.

Synchronous motors

QSY 55 series

Feed motors with 3 pole pairs
 Stall torque 0.4 Nm
 With incremental rotary encoder



Motor	QSY 55C	
Rated voltage U_N	110 V	
Rated power output P_N	0.2 kW	
Rated shaft speed n_N	6000 min ⁻¹	
Rated torque M_N ¹⁾	0.33 Nm	
Rated current I_N ¹⁾	1.4 A	
Stall torque M_0 ¹⁾	0.4 Nm	
Stall current I_0 ¹⁾	1.6 A	
Max. speed n_{max}	8000 min ⁻¹	
Max. torque M_{max} ²⁾	1.4 Nm	
Max. current I_{max} ²⁾	6.15 A	
Weight m	1.4 kg	1.6 kg
Rotor inertia J	0.190 kgcm ²	0.206 kgcm ²
Brake	Without	With
Rated voltage U_{Br}	–	24 V DC
Rated current I_{Br}	–	0.3 A
Holding torque M_{Br}	–	1.0 Nm
ID		
For motor with ERN 1185	524348-03	524348-04

¹⁾ At 100 K ²⁾ Max. 200 ms

Rotatable connections

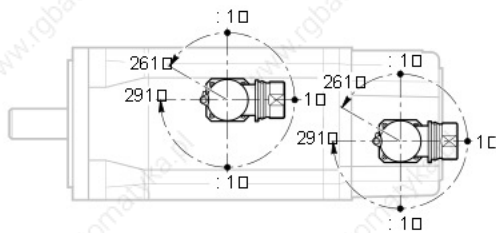

Power connector

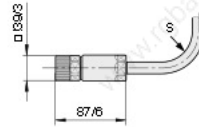

Encoder connector

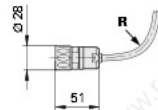

For R, see page 35

QSY 55 C Without brake

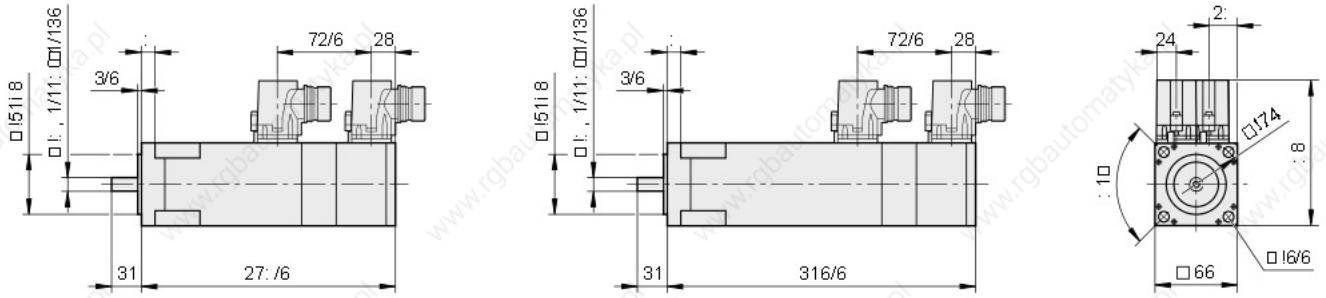

mm

Tolerancing ISO 8015
ISO 2768 - m H
< 6 mm: ± 0.2 mm

Synchronous motors

QSY 96 series

Feed motors with 3 pole pairs
 Stall torque 1.5 Nm and 5.2 Nm
 Choice of incremental or absolute rotary encoder



Motor	QSY 96A		QSY 96G	
Rated voltage U_N	310 V/308 V		291 V/290 V	
Rated power output P_N	0.5 kW/0.45 kW		1.4 kW/1.3 kW	
Rated shaft speed n_N	4 500 min ⁻¹			
Rated torque M_N ¹⁾	1.05 Nm/0.95 Nm		3.0 Nm/2.7 Nm at 4 500 min ⁻¹	
Rated current I_N ¹⁾	1.1 A/1.0 A		3.3 A/3.0 A	
Stall torque M_0 ¹⁾	1.5 Nm		5.2 Nm	
Stall current I_0 ¹⁾	1.5 A		5.2 A	
Max. speed n_{max}	6 000 min ⁻¹			
Max. torque M_{max} ²⁾	5.5 Nm		22 Nm	
Max. current I_{max} ²⁾	6.3 A		25.4 A	
Weight m	3.6 kg	4.5 kg	72 kg	8.1 kg
Rotor inertia J	1.8 kgcm ²	2.1 kgcm ²	6.3 kgcm ²	6.6 kgcm ²
Brake	Without	With	Without	With
Rated voltage U_{Br}	–	24 V DC	–	24 V DC
Rated current I_{Br}	–	0.5 A	–	0.5 A
Holding torque M_{Br}	–	5.0 Nm	–	5.0 Nm
ID				
For motor with ERN 1387	344512-03	344512-04	339875-03	339875-04
For motor with ECN 1313	344512-83	344512-84	339875-83	339875-84
For motor with EQN 1325	344512-53	344512-54	339875-53	339875-54

¹⁾ At 100 K ²⁾ Max. 200 ms

In italics: Data for motors with ECN 1313 or EQN 1325 (rated torque reduced by 10 %)

Rotatable connections

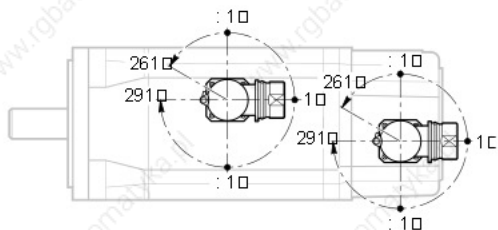

Power connector

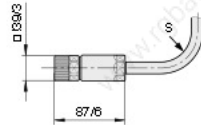

Encoder connector

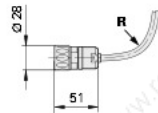

For R, see page 35

QSY 96A Without brake

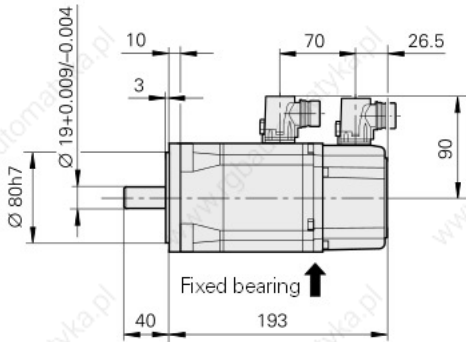

With brake

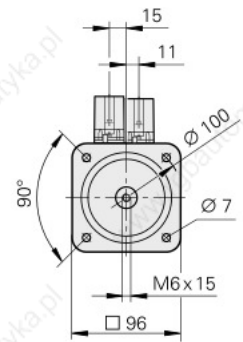
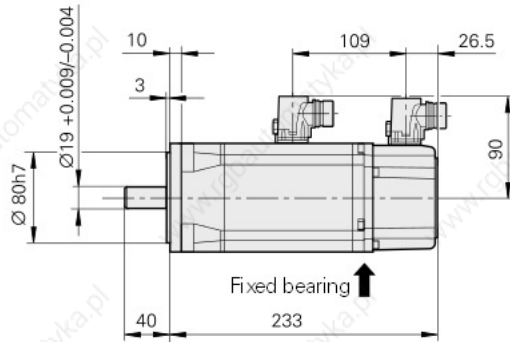

QSY 96G Without brake

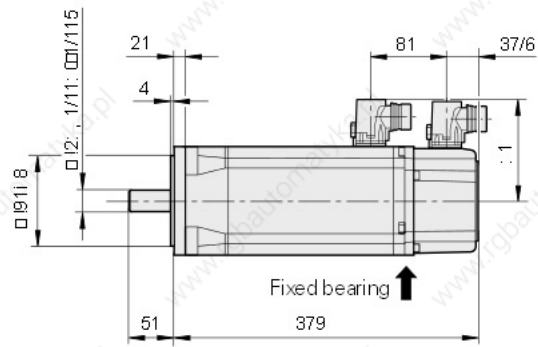

With brake

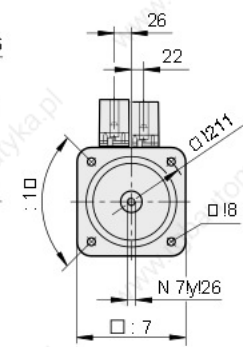
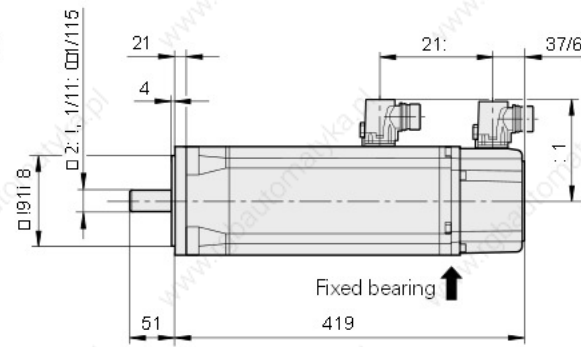

mm

 Tolerancing ISO 8015
 ISO 2768 - m H
 < 6 mm: ± 0.2 mm

Synchronous motors

QSY 116 series

Feed motors with 3 pole pairs
 Stall torque of 5.2 Nm to 10 Nm
 Choice of incremental or absolute rotary encoder



Motor	QSY 116C		QSY 116E		QSY 116J		QSY 116J EcoDyn	
Rated voltage U_N	315 V/311 V		302 V/299 V		290 V/288 V		408 V/405 V	
Rated power output P_N	1.45 kW/1.30 kW		1.85 kW/1.67 kW		2.42 kW/2.18 kW		2.64 kW/2.38 kW	
Rated shaft speed n_N	3000 min ⁻¹						3000 min ⁻¹ ³⁾	
Rated torque M_N ¹⁾	4.6 Nm/4.1 Nm		5.9 Nm/5.3 Nm		7.7 Nm/6.9 Nm		8.4 Nm/7.6 Nm	
Rated current I_N ¹⁾	3.3 A/3.0 A		4.1 A/3.7 A		5.4 A/4.8 A		4.3 A/3.9 A	
Stall torque M_0 ¹⁾	5.2 Nm		7.2 Nm		10.0 Nm		10.0 Nm	
Stall current I_0 ¹⁾	3.3 A		4.8 A		6.8 A		5.0 A	
Max. speed n_{max}	5400 min ⁻¹						4200 min ⁻¹ ³⁾	
Max. torque M_{max} ²⁾	16 Nm		25 Nm		41 Nm		41 Nm	
Max. current I_{max} ²⁾	12.7 A		19.0 A		32.6 A		23.0 A	
Weight m	6.9 kg	7.8 kg	8.6 kg	9.5 kg	12.0 kg	13.3 kg	12.0 kg	13.3 kg
Rotor inertia J	7.5 kgcm ²	7.9 kgcm ²	9.9 kgcm ²	10.3 kgcm ²	15.0 kgcm ²	15.4 kgcm ²	15.0 kgcm ²	15.4 kgcm ²
Brake	Without	With	Without	With	Without	With	Without	With
Rated voltage U_{Br}	–	24 V DC	–	24 V DC	–	24 V DC	–	24 V DC
Rated current I_{Br}	–	0.6 A	–	0.6 A	–	0.85 A	–	0.85 A
Holding torque M_{Br}	–	13.5 Nm	–	13.5 Nm	–	13.5 Nm	–	13.5 Nm
ID								
For motor with ERN 1387	339876-03	339876-04	339877-03	339877-04	339878-03	339878-04	339878-13	339878-14
For motor with ECN 1313	339876-83	339876-84	339877-83	339877-84	–	–	339878-83	339878-84
For motor with EQN 1325	339876-53	339876-54	339877-53	339877-54	339878-53	339878-54	339878-63	339878-64

¹⁾ At 100 K ²⁾ Max. 200 ms ³⁾ In EcoDyn mode
In italics: Data for motors with ECN 1313 or EQN 1325 (rated torque reduced by 10 %)

Rotatable connections

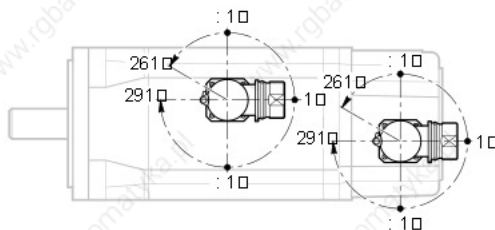

Power connector

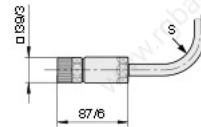

Encoder connector

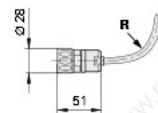

For R, see page 35

mm



Tolerancing ISO 8015

ISO 2768 - m H

< 6 mm: ±0.2 mm

QSY 116C Without brake

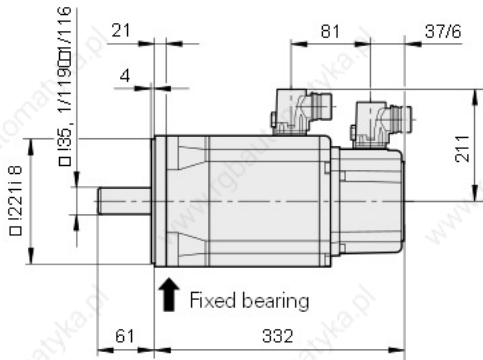

With brake

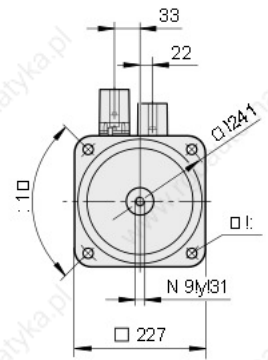
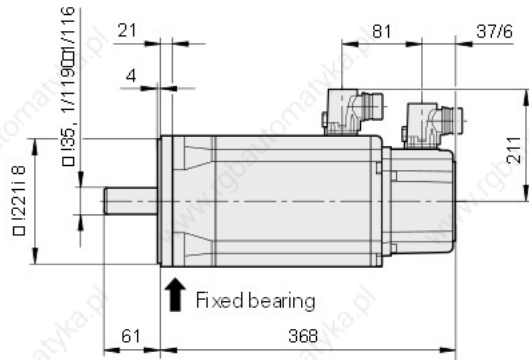

QSY 116E Without brake

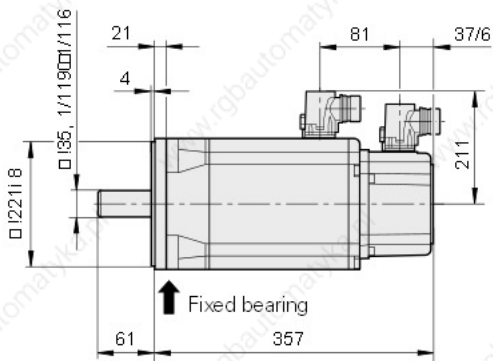

With brake

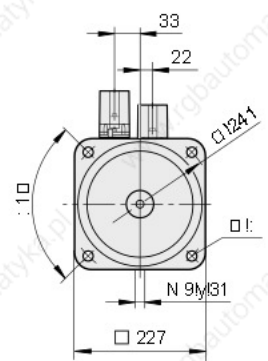
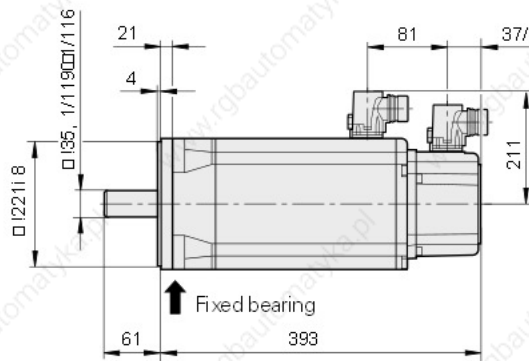

QSY 116J

QSY 116J EcoDyn Without brake

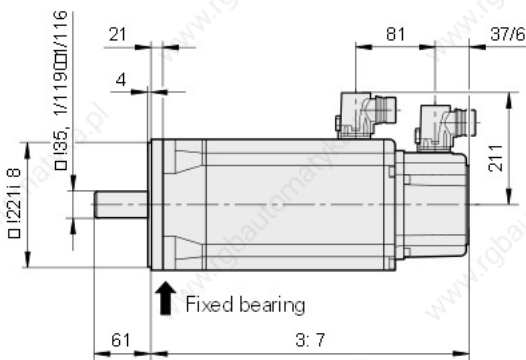

With brake

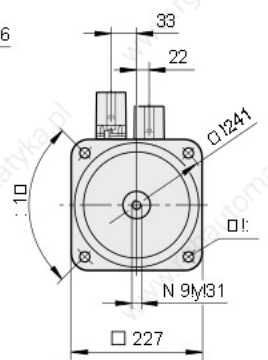
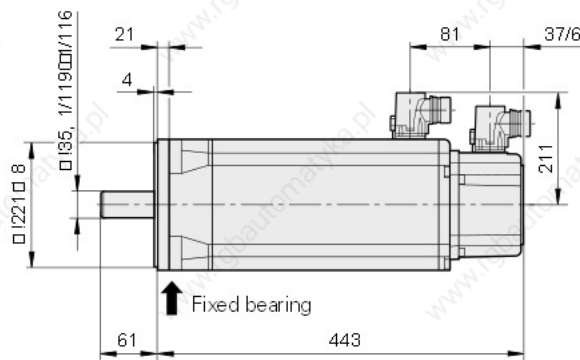

Synchronous motors

QSY 130 EcoDyn series

Feed motors with 4 pole pairs
 Stall torque 6 Nm and 9 Nm
 Choice of incremental or absolute rotary encoder



Motor	QSY 130C EcoDyn		QSY 130E EcoDyn	
Rated voltage U_N	415 V/411 V		407 V/403 V	
Rated power output P_N	1.6 kW/1.5 kW		2.3 kW/2.1 kW	
Rated shaft speed n_N	3000 min ⁻¹ (in EcoDyn mode)			
Rated torque M_N ¹⁾	5.2 Nm/4.7 Nm		7.4 Nm/6.7 Nm	
Rated current I_N ¹⁾	2.7 A/2.4 A		3.8 A/3.4 A	
Stall torque M_0 ¹⁾	6.0 Nm		9.0 Nm	
Stall current I_0 ¹⁾	3.0 A		4.5 A	
Max. speed n_{max}	4200 min ⁻¹ (in EcoDyn mode)			
Max. torque M_{max} ²⁾	16 Nm		23 Nm	
Max. current I_{max} ²⁾	8.6 A		12.7 A	
Weight m	7.9 kg	8.8 kg	9.7 kg	10.6 kg
Rotor inertia J	16.0 kgcm ²	16.4 kgcm ²	21.0 kgcm ²	21.4 kgcm ²
Brake	Without	With	Without	With
Rated voltage U_{Br}	–	24 V DC	–	24 V DC
Rated current I_{Br}	–	0.6 A	–	0.6 A
Holding torque M_{Br}	–	13.5 Nm	–	13.5 Nm
ID				
For motor with ERN 1387	389053-13	389053-14	388422-13	388422-14
For motor with ECN 1313	389053-83	389053-84	388422-83	388422-84
For motor with EQN 1325	389053-63	389053-64	388422-63	388422-64

¹⁾ At 100 K ²⁾ Max. 200 ms

In italics: Data for motors with ECN 1313 or EQN 1325 (rated torque reduced by 10 %)

Rotatable connections

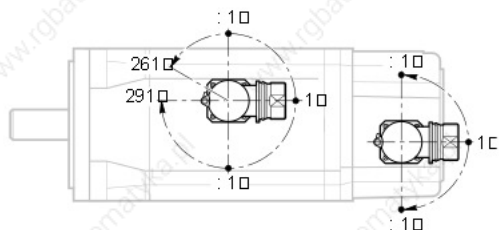

Power connector

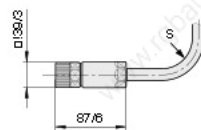

Encoder connector

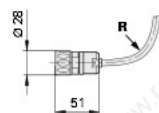

For R, see page 35

QSY 130C Without brake

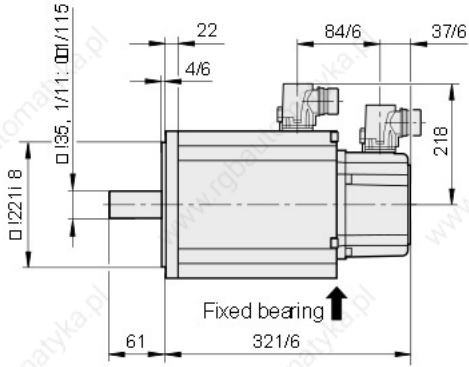

With brake

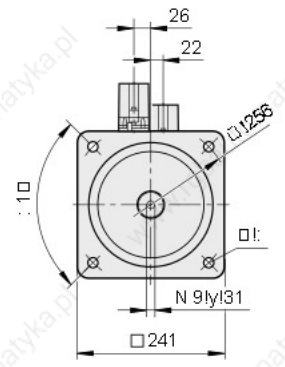
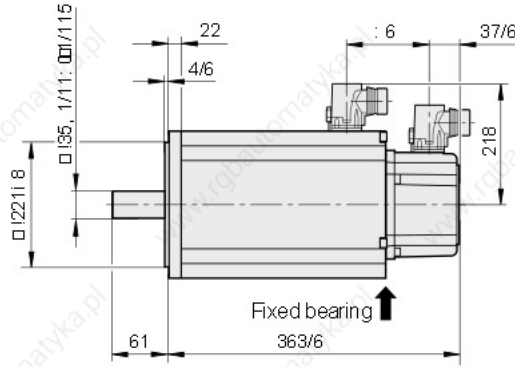

QSY 130E Without brake

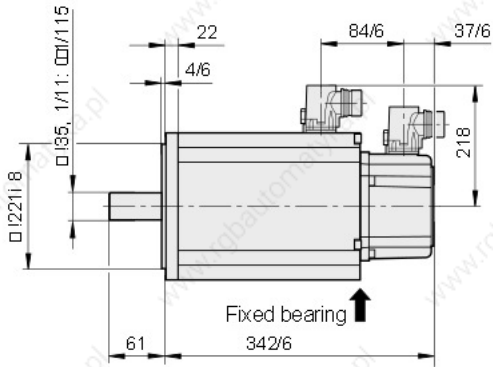

With brake

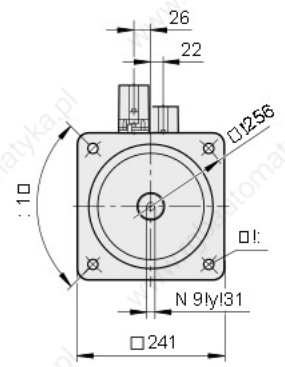
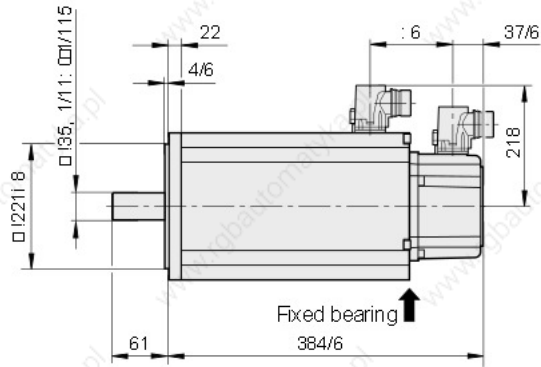

mm

 Tolerancing ISO 8015
 ISO 2768 - m H
 < 6 mm: ± 0.2 mm

Synchronous motors

QSY 155 series

Feed motors with 4 pole pairs
 Stall torque of 13 Nm to 26.1 Nm
 Choice of incremental or absolute rotary encoder



Motor	QSY 155 B		QSY 155 C		QSY 155 D		QSY 155 F	
Rated voltage U_N	298 V/295 V		294 V/291 V		293 V/291 V		289 V/287 V	
Rated power output P_N	2.9 kW/2.6 kW		3.9 kW/3.5 kW		4.6 kW/4.1 kW		5.2 kW/4.7 kW	
Rated shaft speed n_N	3000 min ⁻¹							
Rated torque M_N ¹⁾	9.2 Nm/8.3 Nm		12.5 Nm/11.3 Nm		14.8 Nm/13.3 Nm		16.7 Nm/15.0 Nm	
Rated current I_N ¹⁾	6.9 A/6.2 A		8.7 A/7.8 A		10.6 A/9.5 A		12.0 A/10.8 A	
Stall torque M_0 ¹⁾	13.0 Nm		17.7 Nm		21.6 Nm		26.1 Nm	
Stall current I_0 ¹⁾	9.1 A		11.8 A		14.6 A		18.0 A	
Max. speed n_{max}	5000 min ⁻¹							
Max. torque M_{max} ²⁾	39 Nm		52 Nm		64 Nm		90 Nm	
Max. current I_{max} ²⁾	29.7 A		38.9 A		49.5 A		68.6 A	
Weight m	15.0 kg	18.0 kg	17.5 kg	20.5 kg	20.0 kg	23.0 kg	25.0 kg	28.0 kg
Rotor inertia J	33 kgcm ²	35 kgcm ²	43 kgcm ²	45 kgcm ²	54 kgcm ²	56 kgcm ²	75 kgcm ²	77 kgcm ²
Brake	Without	With	Without	With	Without	With	Without	With
Rated voltage U_{Br}	–	24 V DC	–	24 V DC	–	24 V DC	–	24 V DC
Rated current I_{Br}	–	1.04 A	–	1.04 A	–	1.04 A	–	1.04 A
Holding torque M_{Br}	–	40 Nm	–	40 Nm	–	40 Nm	–	40 Nm
ID								
For motor with ERN 1387	339880-03	339880-04	365308-03	365308-04	339881-03	339881-04	339882-03	339882-04
For motor with EQN 1325	339880-53	339880-54	365308-53	365308-54	339881-53	339881-54	339882-53	339882-54

¹⁾ At 100 K ²⁾ Max. 200 ms

In italics: Data for motors with EQN 1325 (rated torque reduced by 10 %)

Rotatable connections

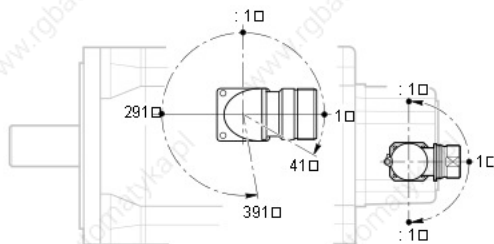

Power connector

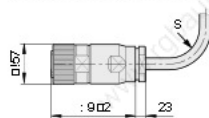

Encoder connector

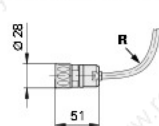

For R, see page 35

mm



Tolerancing ISO 8015

ISO 2768 - m H

< 6 mm: ±0.2 mm

QSY 155 B Without brake

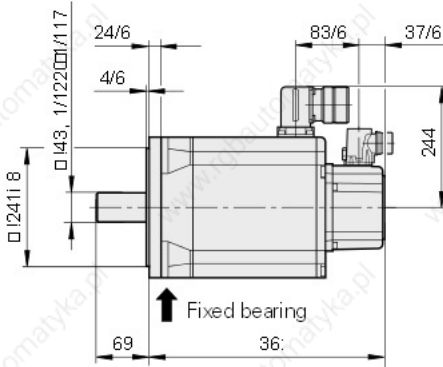

With brake

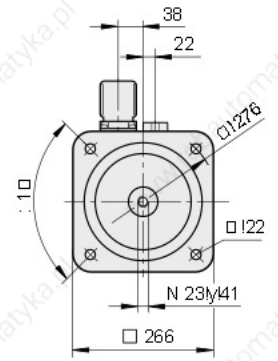
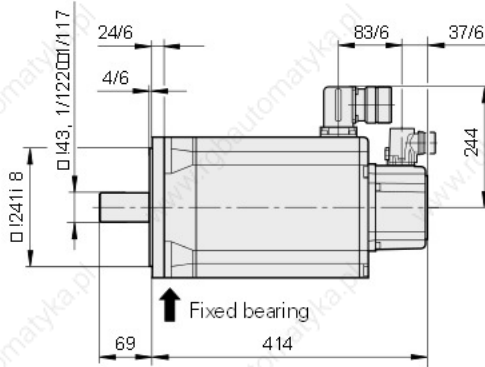

QSY 155 C Without brake

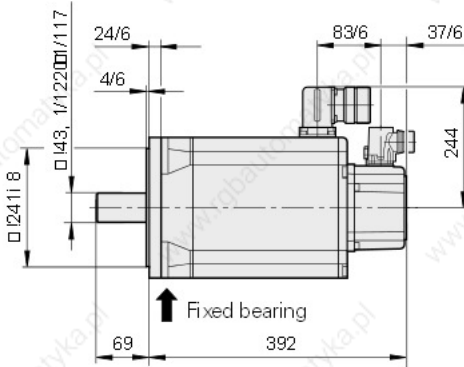

With brake

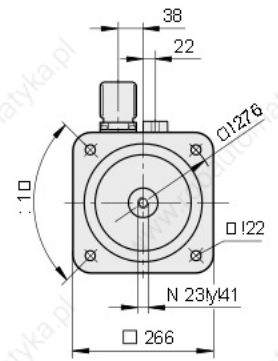
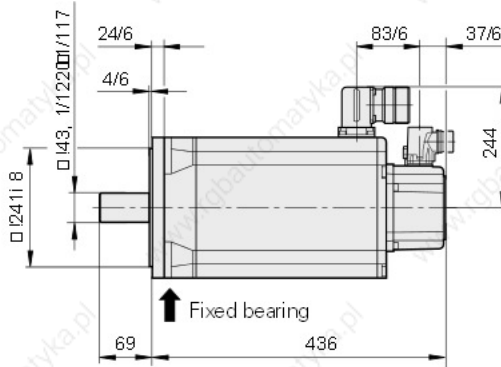

QSY 155 D Without brake

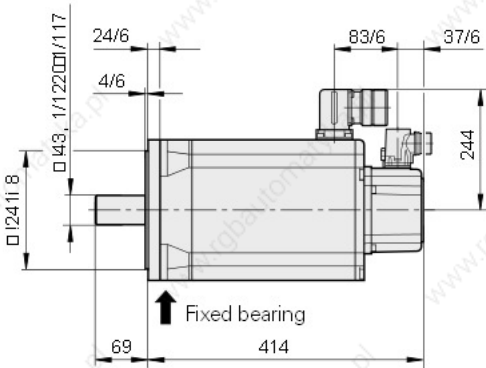

With brake

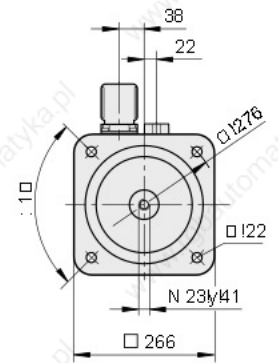
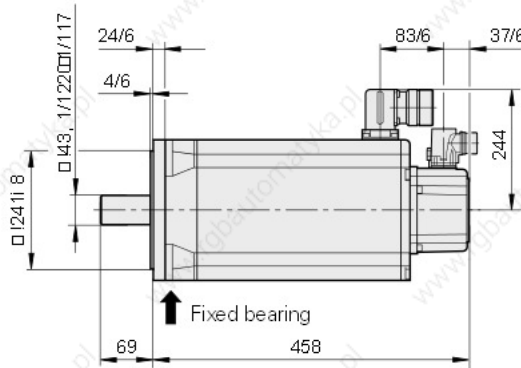

QSY 155 F Without brake

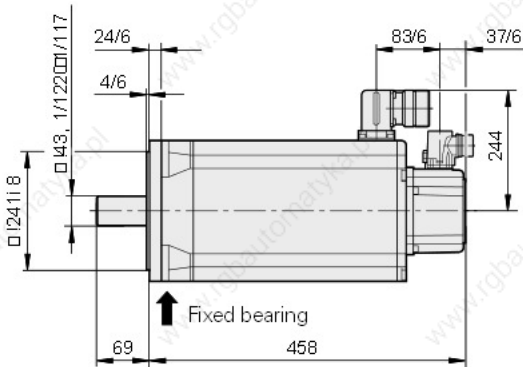

With brake

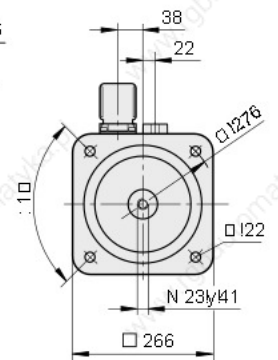
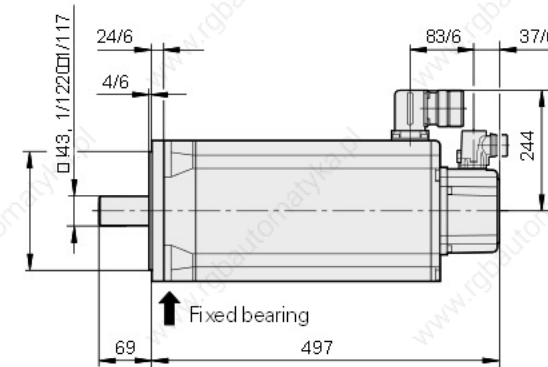

Synchronous motors

QSY 155 EcoDyn series

Feed motors with 4 pole pairs
 Stall torque of 13 Nm to 26.1 Nm
 Choice of incremental or absolute rotary encoder



Motor	QSY 155B EcoDyn		QSY 155C EcoDyn		QSY 155D EcoDyn		QSY 155F EcoDyn	
Rated voltage U_N	417V/412V		420V/415V		412V/407V		399V/397V	
Rated power output P_N	3.5 kW/3.1 kW		5.0 kW/4.5 kW		5.7 kW/5.1 kW		6.0 kW/5.4 kW	
Rated shaft speed n_N	3000 min ⁻¹ (in EcoDyn mode)							
Rated torque M_N ¹⁾	11.0 Nm/9.9 Nm		16.0 Nm/14.4 Nm		18.1 Nm/16.3 Nm		19.2 Nm/17.3 Nm	
Rated current I_N ¹⁾	5.6 A/5.0 A		8.2 A/7.4 A		9.1 A/8.2 A		9.8 A/8.8 A	
Stall torque M_0 ¹⁾	13.0 Nm		17.7 Nm		21.6 Nm		26.1 Nm	
Stall current I_0 ¹⁾	6.5 A		8.5 A		10.6 A		12.8 A	
Max. speed n_{max}	4200 min ⁻¹ (in EcoDyn mode)							
Max. torque M_{max} ²⁾	39 Nm		52 Nm		64 Nm		90 Nm	
Max. current I_{max} ²⁾	21.2 A		27.6 A		35.0 A		49.5 A	
Weight m	15.0 kg	18.0 kg	17.5 kg	20.5 kg	20.0 kg	23.0 kg	25.0 kg	28.0 kg
Rotor inertia J	33 kgcm ²	35 kgcm ²	43 kgcm ²	45 kgcm ²	54 kgcm ²	56 kgcm ²	75 kgcm ²	77 kgcm ²
Brake	Without	With	Without	With	Without	With	Without	With
Rated voltage U_{Br}	-	24 V DC	-	24 V DC	-	24 V DC	-	24 V DC
Rated current I_{Br}	-	1.04 A	-	1.04 A	-	1.04 A	-	1.04 A
Holding torque M_{Br}	-	40 Nm	-	40 Nm	-	40 Nm	-	40 Nm
ID								
For motor with ERN 1387	339880-13	339880-14	365308-13	365308-14	339881-13	339881-14	339882-13	339882-14
For motor with ECN 1313	339880-83	339880-84	365308-83	365308-84	339881-83	339881-84	339882-83	339882-84
For motor with EQN 1325	339880-63	339880-64	365308-63	365308-64	339881-63	339881-64	339882-63	339882-64

¹⁾ At 100 K ²⁾ Max. 200 ms

In italics: Data for motors with ECN 1313 or EQN 1325 (rated torque reduced by 10 %)

Rotatable connections

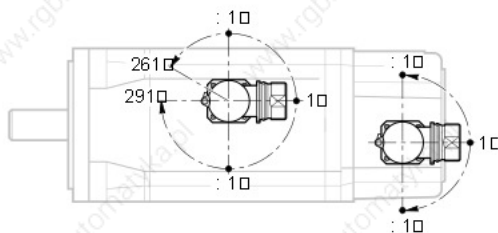

Power connector for QSY 155B/C/D EcoDyn

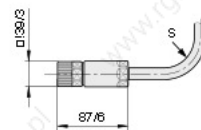

Power connector for QSY 155F EcoDyn

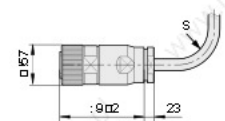

Encoder connector

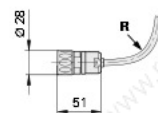

Synchronous motors

QSY 190 EcoDyn series

Feed motors with 4 pole pairs
Stall torque of 28 Nm to 62.5 Nm
Choice of incremental or absolute rotary encoder



Motor	QSY 190C EcoDyn		QSY 190D EcoDyn		QSY 190F EcoDyn		QSY 190K EcoDyn	
Rated voltage U_N	427 V/420 V		421 V/412 V		408 V/404 V		399 V/396 V	
Rated power output P_N	7.2 kW/6.5 kW		9.6 kW/8.6 kW		9.9 kW/8.9 kW		12.2 kW/11.0 kW	
Rated shaft speed n_N	3000 min ⁻¹ (in EcoDyn mode)							
Rated torque M_N ¹⁾	23.0 Nm/20.7 Nm		30.6 Nm/27.5 Nm		31.5 Nm/28.4 Nm		39.0 Nm/35.1 Nm	
Rated current I_N ¹⁾	11.8 A/10.6 A		14.4 A/13.0 A		15.0 A/13.5 A		20.2 A/18.2 A	
Stall torque M_0 ¹⁾	28.0 Nm		38.0 Nm		47.6 Nm		62.5 Nm	
Stall current I_0 ¹⁾	14.0 A		18.1 A		22.7 A		29.8 A	
Max. speed n_{max}	3900 min ⁻¹ (in EcoDyn mode)							
Max. torque M_{max} ²⁾	85 Nm		107 Nm		150 Nm		240 Nm	
Max. current I_{max} ²⁾	50.2 A		62.9 A		88.4 A		134.3 A	
Weight m	29.0 kg	37.0 kg	33.5 kg	41.5 kg	42.5 kg	50.5 kg	61 kg	69.0 kg
Rotor inertia J	106 kgcm ²	115 kgcm ²	133 kgcm ²	142 kgcm ²	190 kgcm ²	199 kgcm ²	290 kgcm ²	299 kgcm ²
Brake	Without	With	Without	With	Without	With	Without	With
Rated voltage U_{Br}	–	24 V DC	–	24 V DC	–	24 V DC	–	24 V DC
Rated current I_{Br}	–	1.38 A	–	1.38 A	–	1.38 A	–	1.38 A
Holding torque M_{Br}	–	70 Nm	–	70 Nm	–	70 Nm	–	70 Nm
ID								
For motor with ERN 1387	392023-13	392023-14	392024-13	392024-14	388244-13	388244-14	392025-13	392025-14
For motor with ECN 1313	392023-83	392023-84	392024-83	392024-84	388244-83	388244-84	392025-83	392025-84
For motor with EQN 1325	392023-63	392023-64	392024-63	392024-64	388244-63	388244-64	392025-63	392025-64

¹⁾ At 100 K ²⁾ Max. 200 ms

In italics: Data for motors with ECN 1313 or EQN 1325 (rated torque reduced by 10 %)

Rotatable connections

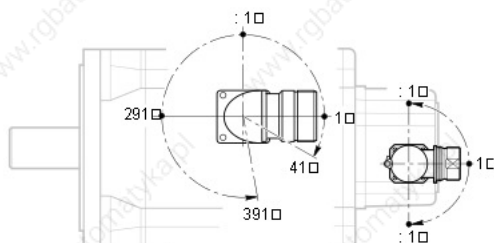

Power connector

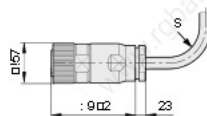

Encoder connector

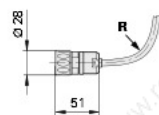

For R, see page 35

mm



Tolerancing ISO 8015

ISO 2768 - m H

< 6 mm: ±0.2 mm

QSY 190C EcoDyn Without brake

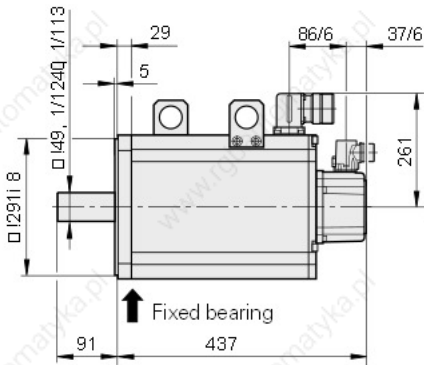

With brake

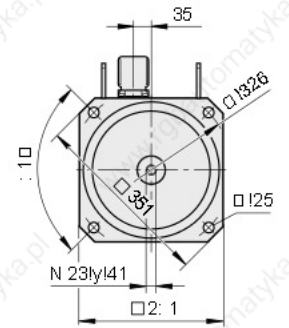
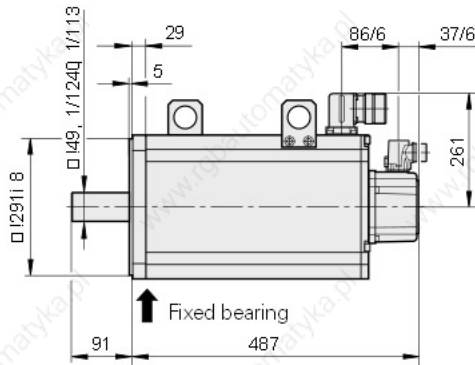

QSY 190D EcoDyn Without brake

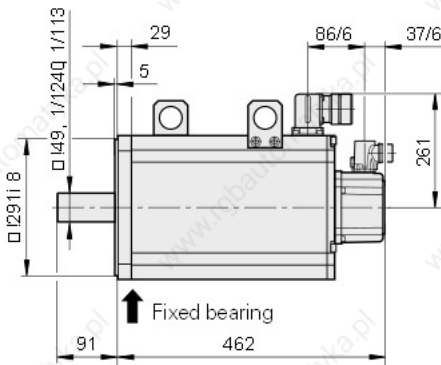

With brake

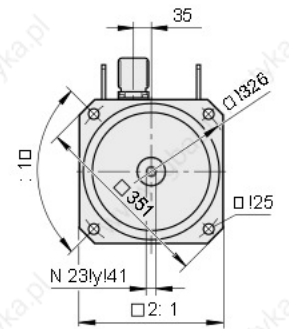
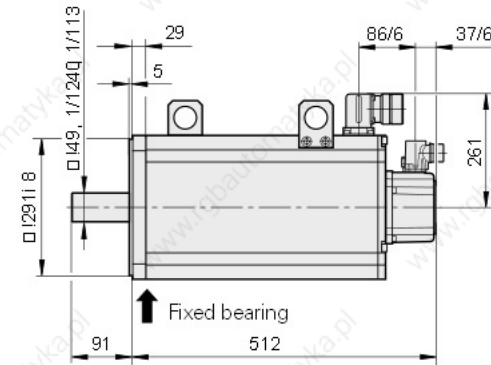

QSY 190F EcoDyn Without brake

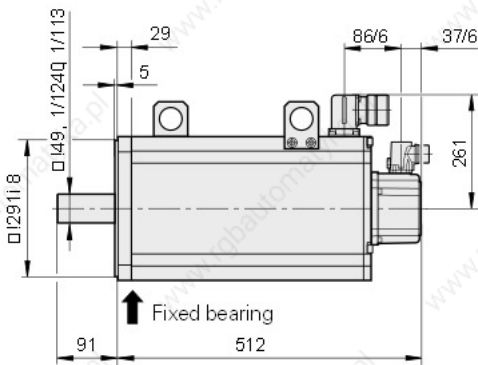

With brake

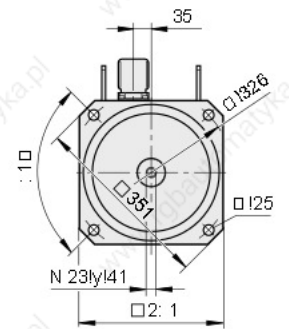
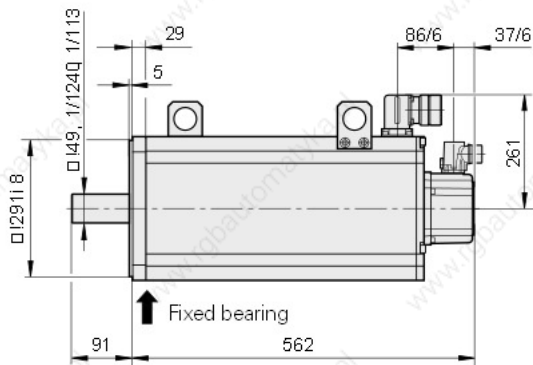

QSY 190K EcoDyn Without brake

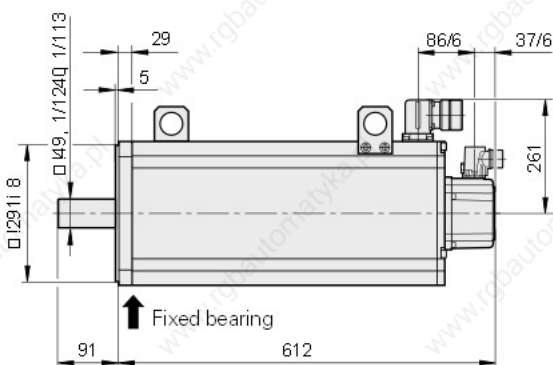

With brake

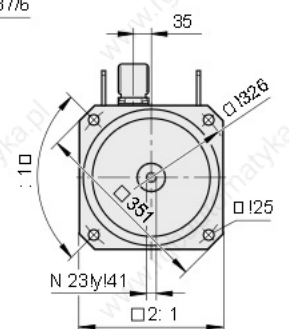
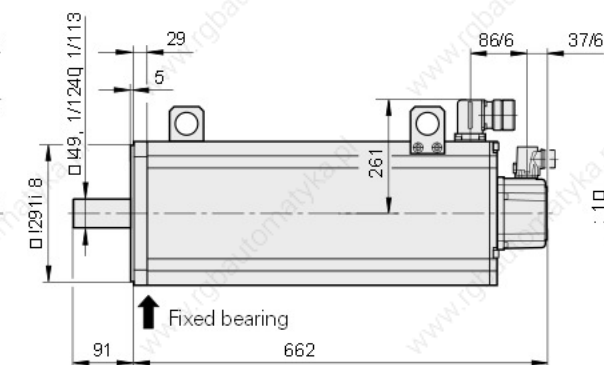

Synchronous motors

Torque characteristics

--- Characteristic curve according to the specifications
 — Measured characteristic curve of one motor

*) Characteristic curve at maximum motor current
 **) Characteristic curve when using compact inverters

QSY 55C

*) $M_{max} = 1.4 \text{ Nm}$ at $I_{max} = 6.15 \text{ A}_{eff}$

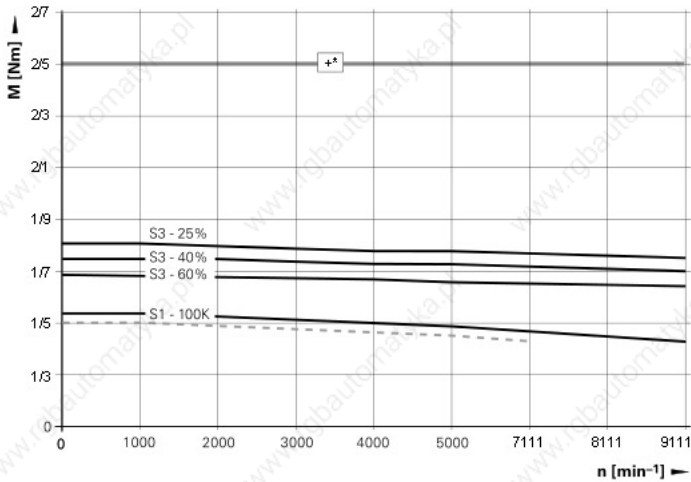

QSY 116C

*) $M_{max} = 16 \text{ Nm}$ at $I_{max} = 12.7 \text{ A}_{eff}$

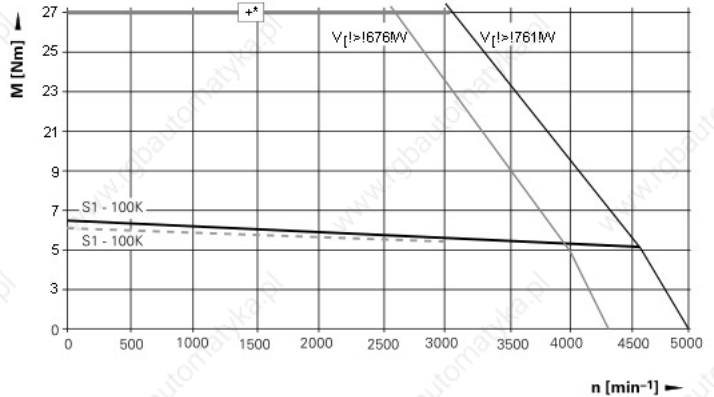

QSY 96A

*) $M_{max} = 5.5 \text{ Nm}$ at $I_{max} = 6.3 \text{ A}_{eff}$

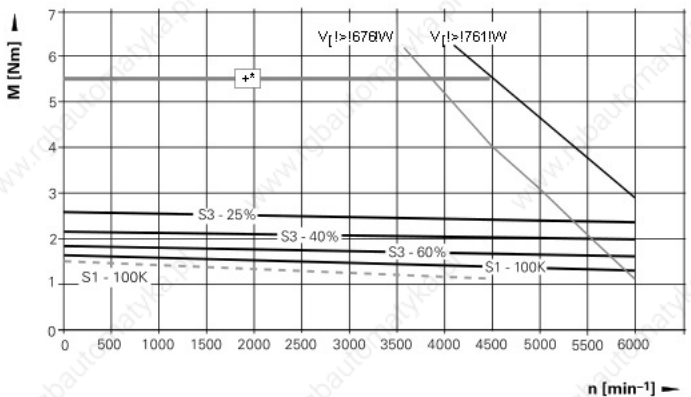

QSY 116E

*) $M_{max} = 25 \text{ Nm}$ at $I_{max} = 19 \text{ A}_{eff}$
 **) $M_{max} = 21 \text{ Nm}$ at $I_{max} = 15 \text{ A}_{eff}$

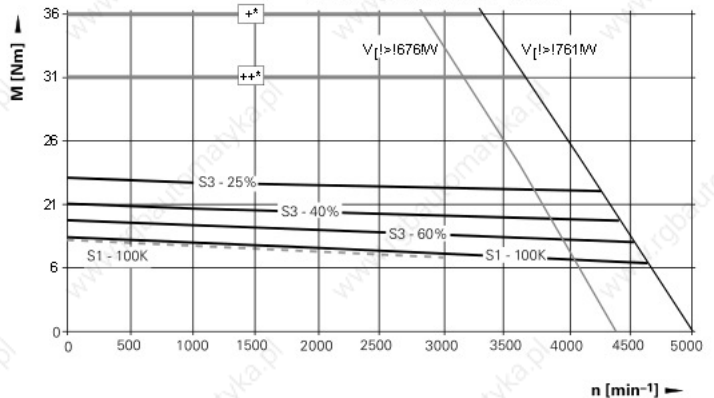

QSY 96G

*) $M_{max} = 22 \text{ Nm}$ at $I_{max} = 25.4 \text{ A}_{eff}$
 **) $M_{max} = 14 \text{ Nm}$ at $I_{max} = 15 \text{ A}_{eff}$

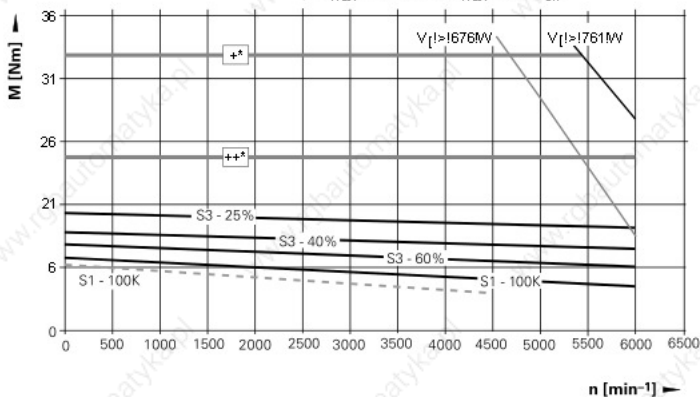

QSY 116J

*) $M_{max} = 41 \text{ Nm}$ at $I_{max} = 32.6 \text{ A}_{eff}$
 **) $M_{max} = 21 \text{ Nm}$ at $I_{max} = 15 \text{ A}_{eff}$

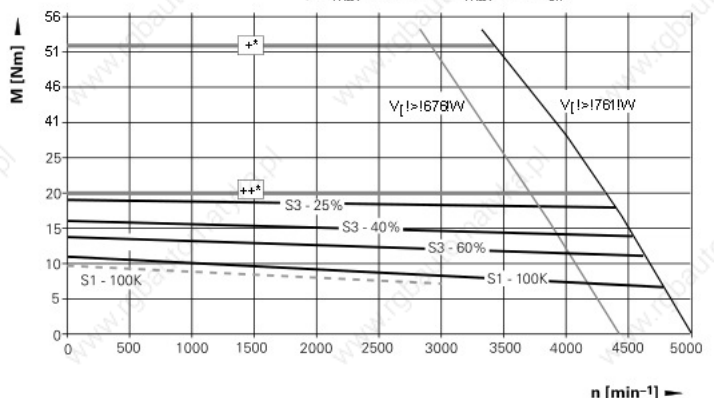

QSY 116J EcoDyn

*) $M_{max} = 41 \text{ Nm}$ at $I_{max} = 23 \text{ A}_{eff}$
 **) $M_{max} = 29 \text{ Nm}$ at $I_{max} = 15 \text{ A}_{eff}$

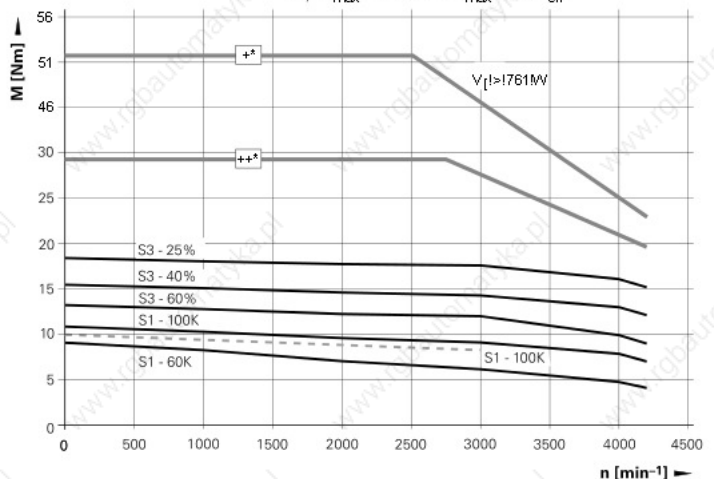

Notes

s The characteristic curves apply to motors with ERN 1387.

s S3 mode

Cycle duration 10 min.
 In the rest period the motor must be stopped and disconnected from power.

QSY 130C EcoDyn

*) $M_{max} = 16 \text{ Nm}$ at $I_{max} = 8.6 \text{ A}_{eff}$
 **) $M_{max} = 14.5 \text{ Nm}$ at $I_{max} = 7.5 \text{ A}_{eff}$

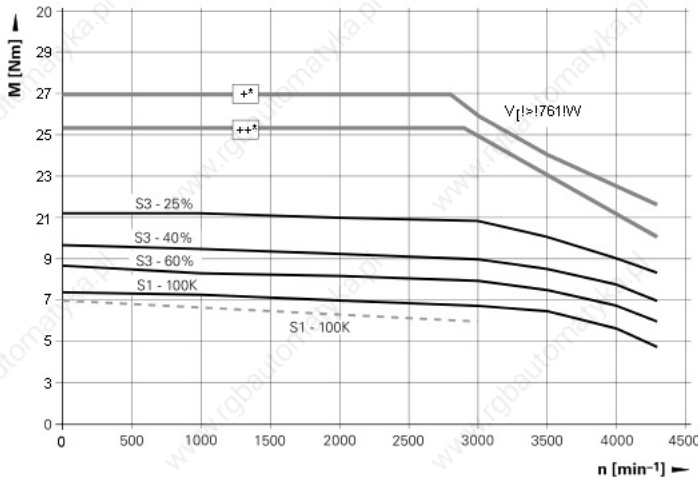

QSY 155B

*) $M_{max} = 39 \text{ Nm}$ at $I_{max} = 29.7 \text{ A}_{eff}$
 **) $M_{max} = 21 \text{ Nm}$ at $I_{max} = 15 \text{ A}_{eff}$

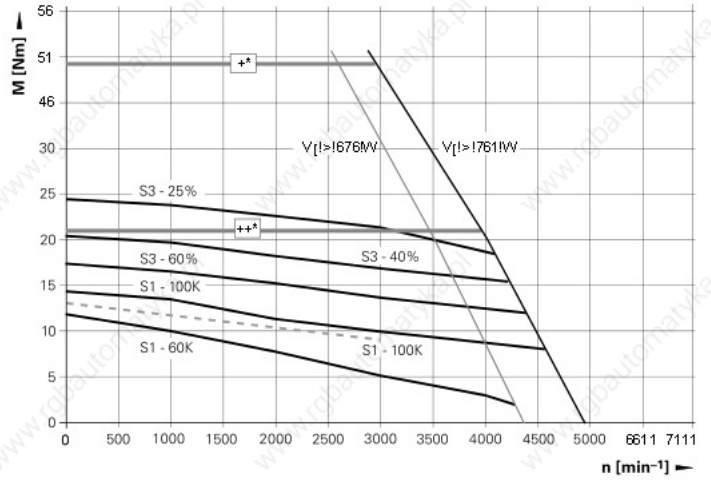

QSY 130E EcoDyn

*) $M_{max} = 23 \text{ Nm}$ at $I_{max} = 12.7 \text{ A}_{eff}$
 **) $M_{max} = 14.5 \text{ Nm}$ at $I_{max} = 7.5 \text{ A}_{eff}$

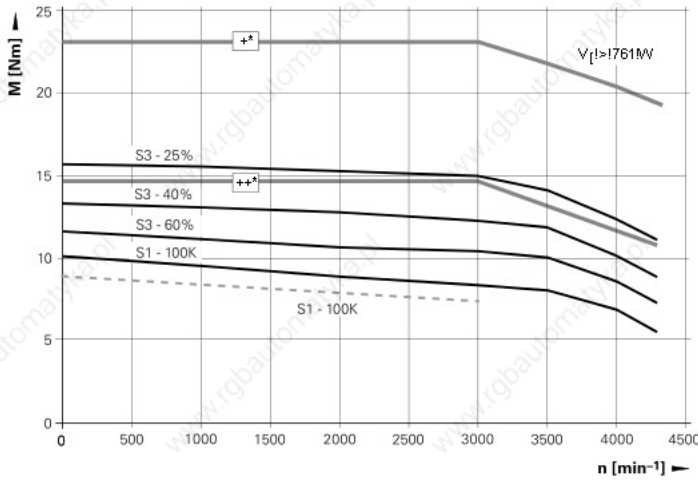

QSY 155C

*) $M_{max} = 52 \text{ Nm}$ at $I_{max} = 38.9 \text{ A}_{eff}$
 **) $M_{max} = 42 \text{ Nm}$ at $I_{max} = 30 \text{ A}_{eff}$

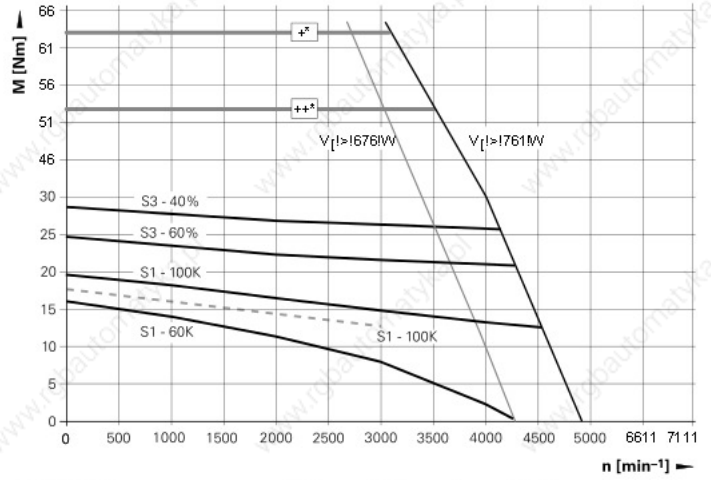

QSY 155D

*) $M_{max} = 64 \text{ Nm}$ at $I_{max} = 49.5 \text{ A}_{eff}$
 **) $M_{max} = 42 \text{ Nm}$ at $I_{max} = 30 \text{ A}_{eff}$

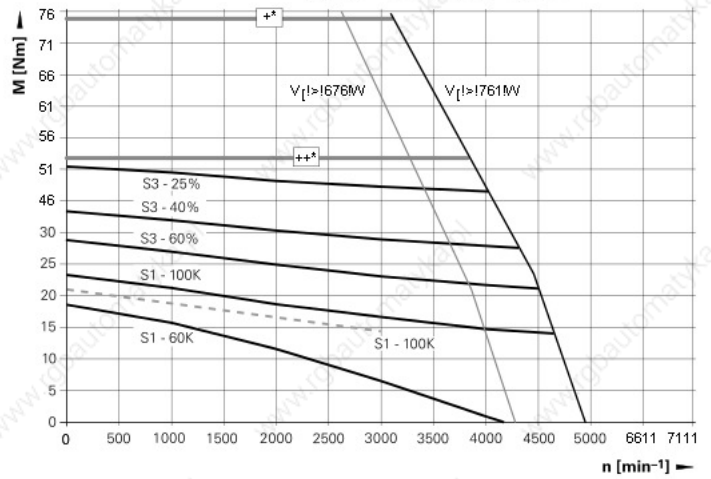

QSY 155F

*) $M_{max} = 90 \text{ Nm}$ at $I_{max} = 68.6 \text{ A}_{eff}$
 **) $M_{max} = 64 \text{ Nm}$ at $I_{max} = 46 \text{ A}_{eff}$

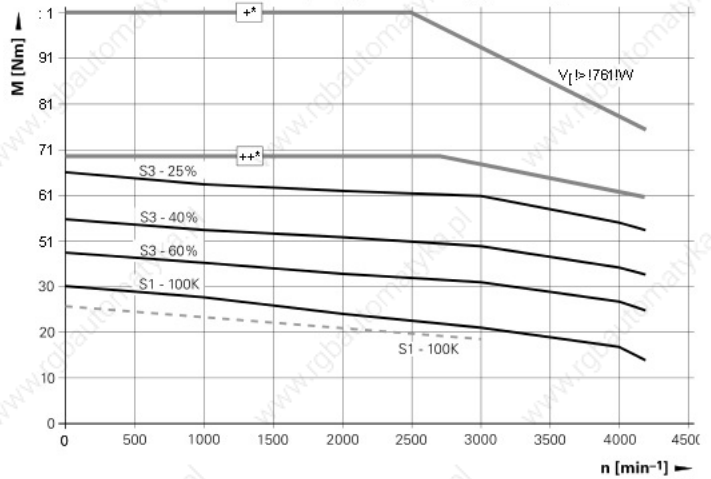

QSY 155 B EcoDyn

*) $M_{max} = 39 \text{ Nm}$ at $I_{max} = 21.2 \text{ A}_{eff}$
 **) $M_{max} = 29 \text{ Nm}$ at $I_{max} = 15 \text{ A}_{eff}$

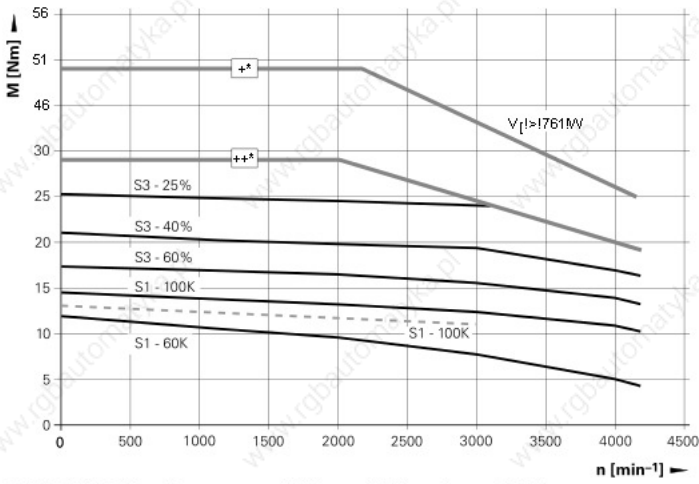

QSY 190 C EcoDyn

*) $M_{max} = 85 \text{ Nm}$ at $I_{max} = 50.2 \text{ A}_{eff}$
 **) $M_{max} = 59 \text{ Nm}$ at $I_{max} = 30 \text{ A}_{eff}$

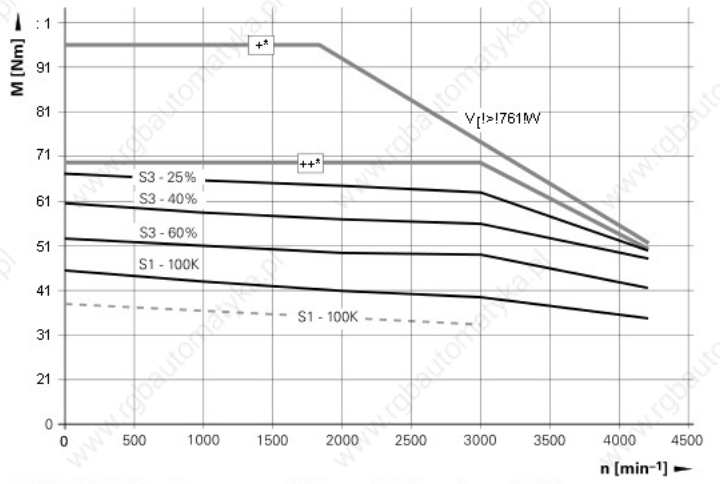

QSY 155 C EcoDyn

*) $M_{max} = 52 \text{ Nm}$ at $I_{max} = 27.6 \text{ A}_{eff}$
 **) $M_{max} = 29 \text{ Nm}$ at $I_{max} = 15 \text{ A}_{eff}$

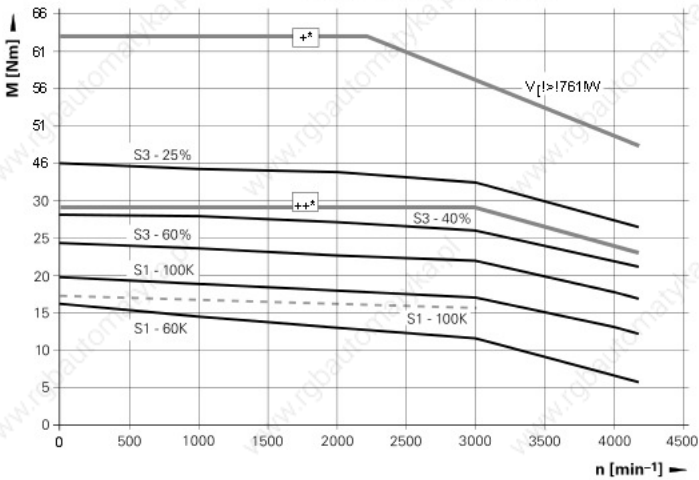

QSY 190 D EcoDyn

*) $M_{max} = 107 \text{ Nm}$ at $I_{max} = 62.9 \text{ A}_{eff}$
 **) $M_{max} = 59 \text{ Nm}$ at $I_{max} = 30 \text{ A}_{eff}$

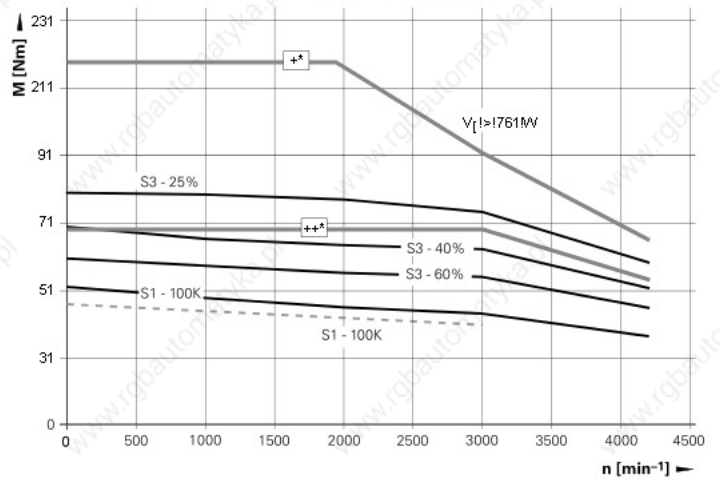

QSY 155 D EcoDyn

*) $M_{max} = 64 \text{ Nm}$ at $I_{max} = 35 \text{ A}_{eff}$
 **) $M_{max} = 59 \text{ Nm}$ at $I_{max} = 30 \text{ A}_{eff}$

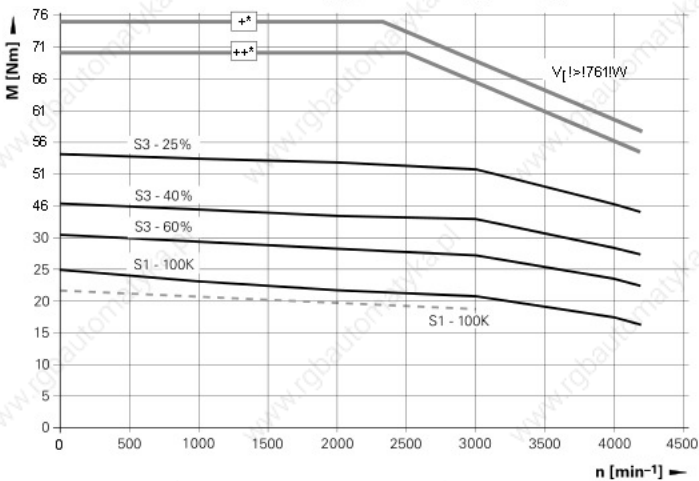

QSY 190 F EcoDyn

*) $M_{max} = 150 \text{ Nm}$ at $I_{max} = 88.4 \text{ A}_{eff}$
 **) $M_{max} = 59 \text{ Nm}$ at $I_{max} = 30 \text{ A}_{eff}$

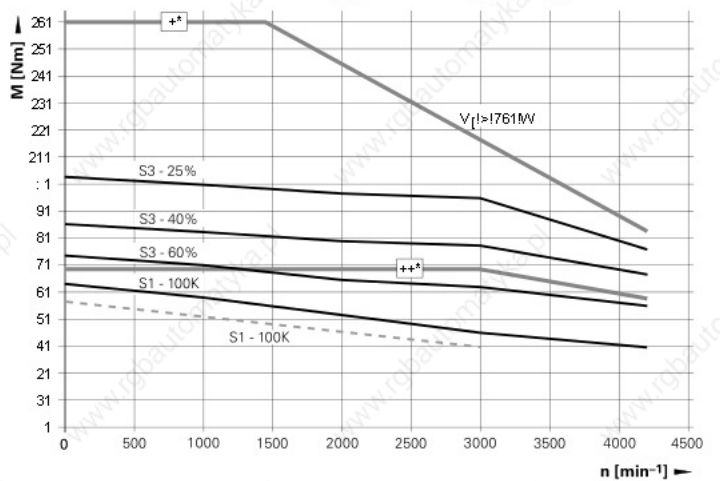

QSY 155 F EcoDyn

*) $M_{max} = 90 \text{ Nm}$ at $I_{max} = 49.5 \text{ A}_{eff}$
 **) $M_{max} = 59 \text{ Nm}$ at $I_{max} = 30 \text{ A}_{eff}$

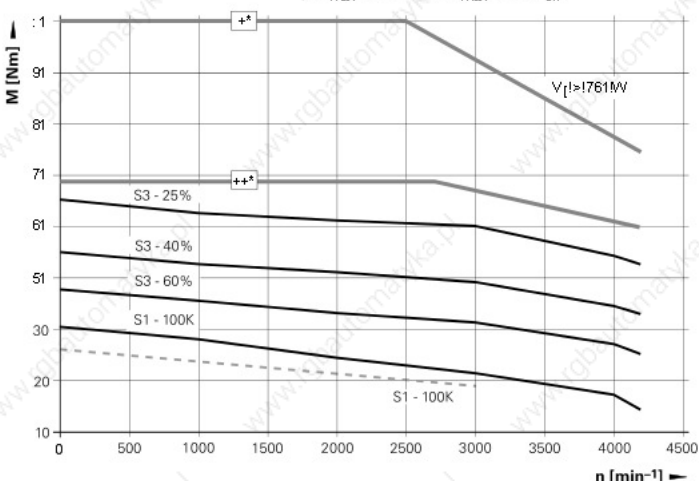

QSY 190 K EcoDyn

*) $M_{max} = 240 \text{ Nm}$ at $I_{max} = 134.3 \text{ A}_{eff}$
 **) $M_{max} = 123 \text{ Nm}$ at $I_{max} = 64 \text{ A}_{eff}$

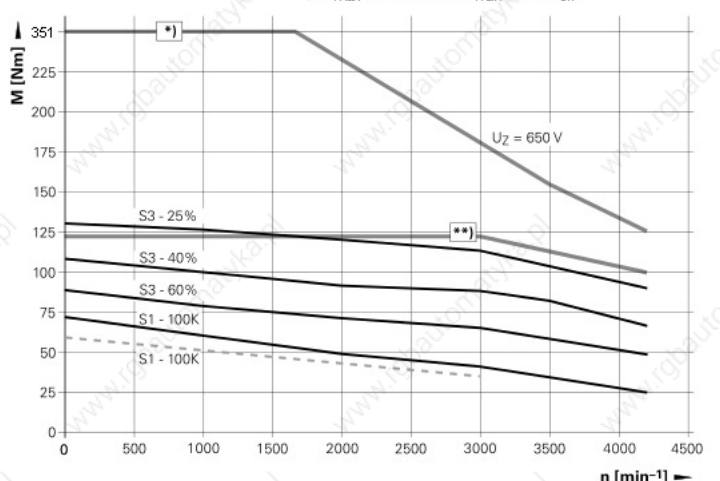

Synchronous motors

Cables and connectors

Power cables

Current load at ambient temperature up to 40 °C

	Cable with one connector ID	Connector ID	Cable without connectors ID	Bend radius R for frequent flexing	Cable type	Diameter
Current load up to 13.8 A						
QSY 55 QSY 96 QSY 116 QSY 130 QSY 155B EcoDyn QSY 155C EcoDyn QSY 155D EcoDyn	352960-xx	325165-02	348948-01	□ 65 mm	PUR [4 x 1.5 mm ² + (2 x 1.0 mm ²)]	12.5 mm
QSY 155B QSY 155C QSY 155F EcoDyn	352962-xx	333090-02				
Current load up to 26.0 A						
QSY 155D QSY 155F QSY 190C EcoDyn QSY 190D EcoDyn QSY 190F EcoDyn	352963-xx	333090-02	348948-03	□ 75 mm	PUR [4 x 4 mm ² + (2 x 1.0 mm ²)]	14.8 mm
Current load up to 32.8 A						
QSY 190K EcoDyn	393570-xx	333090-03	348948-04	□ 85 mm	PUR [4 x 6 mm ² + (2 x 1.0 mm ²)]	16.4 mm

Encoder cables

	Cable length	Cable complete with connectors ID	Line drop compensator ID	Extension cable ID	Bend radius R for frequent flexing
QSY with ECN 1313 or EQN 1325	< 15 m	336376-xx	–	340302-xx (as required)	□ 100 mm
	> 15 m	336376-xx	370224-01	340302-xx	
QSY synchronous motor with ERN 1185 or ERN 1387	< 30 m	289440-xx	–	336847-xx (as required)	□ 100 mm
	> 30 m	289440-xx	370226-01	336847-xx	

Asynchronous motors

QAN overview

General technical information

Speed measurement

- An integrated rotary encoder from HEIDENHAIN measures the shaft speed.
- s ERN 1381 with 1024 lines for motors with stub shaft
 - s ERM 280 with 600 lines for motors with hollow shaft and QAN 200 M/18 000

Specifications

The specifications and the characteristic curves apply to motors mounted without thermal insulation. The temperature may differ from the maximum permissible ambient temperature of 40 °C by a maximum of 105 K. If the motor is mounted so that it is thermally insulated, it is necessary to reduce the motor torque in order to avoid thermal overloading of the motor.

Shaft bearing

HEIDENHAIN asynchronous motors are equipped with maintenance-free bearings. The shaft bearing on **motors with stub shaft** is optionally available as either standard bearing or as spindle bearing. The version with spindle bearing can withstand greater radial forces and allows higher spindle speeds. Motors with spindle bearing have a slightly larger overall length.

The **hollow-shaft motors** always have spindle bearings.

Mechanical life

The service life of the bearings depends on the shaft load and the average shaft speed (see the *Inverter Systems and Motors* Technical Manual). The nominal bearing service life—which depends on the specific motor and applies for a certain maximum shaft load at an average shaft speed—is 10 000 hours for QAN motors.

Shaft end

QAN asynchronous motors from HEIDENHAIN have a cylindrical shaft end as per DIN 748-1. The stub-shaft motors have a centering hole as per DIN 332-DR.

Asynchronous motors with **standard bearing** are supplied with keyway and feather key as per DIN 6885-1 and are full-key balanced. They are also available with smooth shaft upon request.

Feather key:
QAN 200: AS 10 x 8 x 70
QAN 260: AS 12 x 8 x 90
QAN 320: AS 16 x 10 x 90

The standard version of the asynchronous motors **with spindle bearing** has a smooth shaft (without keyway and feather key). Upon request motors with stub shaft are also available with keyway and feather key as per DIN 6885-1.

Precision balancing

QAN asynchronous motors from HEIDENHAIN can be balanced at any time.

Hollow-shaft motors

The QAN 200 UH and QAN 260 xH motors with hollow shaft are suited for direct mounting to mechanical spindles. The hollow shaft permits you to convey coolant to tools with inner cooling.

The coolant is introduced at the rear of the motor through a rotating manifold (e.g. from Deublin, order no.: 1109-020-188). The shaft end is designed for this.

Mechanical data

Design IM B35 (mounting via flange/base) according to EN 60034-7

Mounting of the motor

We recommend using the following screws according to DIN EN ISO 4017 to mount the motor:

Fastening:	Flange	Base
QAN 200	M12 x 30	M10 x 30
QAN 260	M16 x 40	M12 x 35
QAN 320	M18 x 60	M14 x 40

Flange: Dimensions as per DIN 42 948 and IEC 72

Protection as per EN 60 529

Motor: IP 54

Shaft end: IP 43

Vibration severity

Grade SR (external precision balancing possible)
(IEC 60034-14)

Thermal specifications

Separate cooling via integrated fan

Temperature monitoring with KTY 84-130 thermistor in the stator winding

Thermal class F

Asynchronous motors with stub shaft	Rated power output	Rated speed	Max. speed		Rated torque	Rated current	Recommended inverters			Page
			Standard bearing	Spindle bearing			1-axis module	2-axis module	Compact inverter	
QAN 200M	5.5 kW	1500 min ⁻¹	9000 min ⁻¹	12000 min ⁻¹	35.0 Nm	18.0 A	UM 112D	UM 122 D	Spindle output	26
QAN 200L	7.5 kW	1500 min ⁻¹	9000 min ⁻¹	12000 min ⁻¹	47.8 Nm	20.1 A	UM 112D	UM 122 D	Spindle output	
QAN 200U	10.0 kW	1500 min ⁻¹	9000 min ⁻¹	12000 min ⁻¹	63.7 Nm	25.0 A	UM 112D	UM 122 D	Spindle output ¹⁾	
QAN 260M	15.0 kW	1500 min ⁻¹	8000 min ⁻¹	10000 min ⁻¹	95.5 Nm	35.0 A	UM 113D	–	Spindle output ²⁾	28
QAN 260L	20.0 kW	1500 min ⁻¹	8000 min ⁻¹	10000 min ⁻¹	127.3 Nm	46.0 A	UM 113D	–	–	
QAN 260U	24.0 kW	1500 min ⁻¹	8000 min ⁻¹	10000 min ⁻¹	152.8 Nm	58.0 A	UM 114D	–	–	
QAN 260W	12.0 kW	750 min ⁻¹	8000 min ⁻¹	10000 min ⁻¹	152.8 Nm	29.0 A	UM 112D	–	Spindle output ²⁾	
QAN 320M	32.0 kW	1500 min ⁻¹	8000 min ⁻¹	10000 min ⁻¹	203.7 Nm	77.5 A	UM 114D	–	–	30
QAN 320L	40.0 kW	1500 min ⁻¹	8000 min ⁻¹	10000 min ⁻¹	254.6 Nm	99.0 A	UM 115D	–	–	
QAN 320W	18.0 kW	750 min ⁻¹	8000 min ⁻¹	10000 min ⁻¹	229.2 Nm	43.0 A	UM 114D	–	–	

Asynchronous motors with hollow shaft	Rated power output	Rated speed	Max. speed		Rated torque	Rated current	Recommended inverters			Page
			Standard bearing	Spindle bearing			1-axis module	2-axis module	Compact inverter	
QAN 200UH	10.0 kW	1500 min ⁻¹	–	12000 min ⁻¹ 15000 min ⁻¹	63.7 Nm	25.0 A	UM 112D	UM 122 D	Spindle output ¹⁾	32
QAN 260MH	15.0 kW	1500 min ⁻¹	–	12000 min ⁻¹	96.0 Nm	35.0 A	UM 113D	–	Spindle output ²⁾	34
QAN 260LH	20.0 kW	1500 min ⁻¹	–	12000 min ⁻¹	128.0 Nm	46.0 A	UM 113D	–	–	
QAN 260UH	22.0 kW	1500 min ⁻¹	–	10000 min ⁻¹ 12000 min ⁻¹	140.0 Nm	54.0 A	UM 113D ¹⁾ UM 114D ³⁾	–	–	

¹⁾ Only UE 24xB, UR 24x

²⁾ Only UR 24x

³⁾ Depending on the required acceleration of the spindle (I_{max})

Asynchronous motors with stub shaft

QAN 200 series

Spindle motors with 2 pole pairs
 Rated power output 5.5 kW to 10 kW
 Choice of standard or spindle bearing

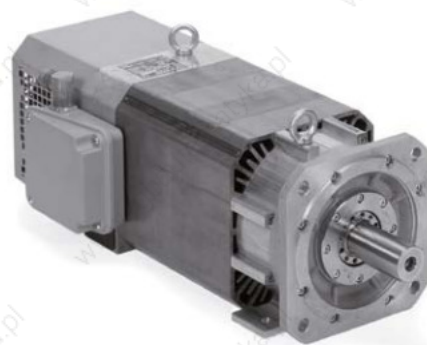

Motor	QAN 200M	QAN 200L	QAN 200U
Rated voltage U_N	250 V	305 V	330 V
Rated power output P_N	5.5 kW	7.5 kW	10.0 kW
Rated shaft speed n_N	1 500 min^{-1}		
Rated torque M_N (105 K)	35.0 Nm	478 Nm	63.7 Nm
Rated current I_N (105 K)	18.0 A	20.1 A	25.0 A
Efficiency	0.85		
Max. speed n_{max} ¹⁾ Standard bearing Spindle bearing	9 000 min^{-1} 12 000 min^{-1}	9 000 min^{-1} 12 000 min^{-1}	
Max. current I_{max}	33 A	36 A	44 A
Weight m	51 kg	68 kg	83 kg
Rotor inertia J	245 kgcm^2	353 kgcm^2	405 kgcm^2
Protection	IP 54		
Fan Rated voltage U_L Rated current I_L Frequency f_L	3 x 400 V AC 0.2 A 50 Hz/60 Hz		
ID Motor with standard bearing Motor with spindle bearing	374328-01 374328-13	374329-01 374329-13	374330-01 374330-13

¹⁾ The max. speed depends on the motor's application conditions, such as the shaft load (see the *Inverter Systems and Motors* Technical Manual).

Rotatable connections

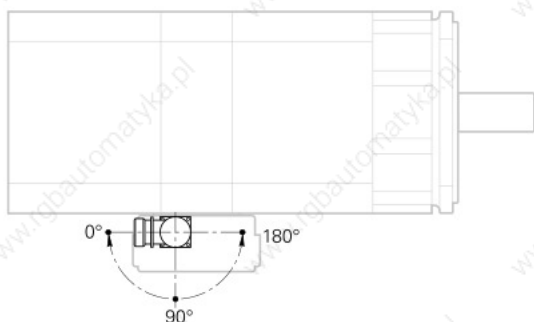

Encoder connector

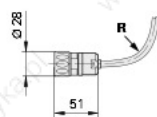

For R, see page 61

mm



Tolerancing ISO 8015

ISO 2768 - m H

< 6 mm: ±0.2 mm

QAN 200M

With standard bearing

With spindle bearing

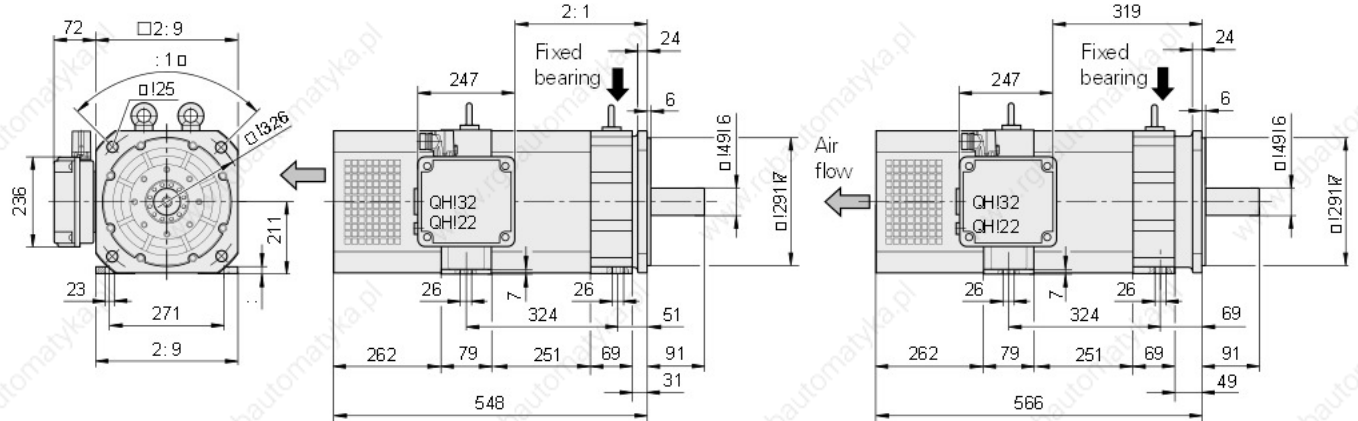

QAN 200L

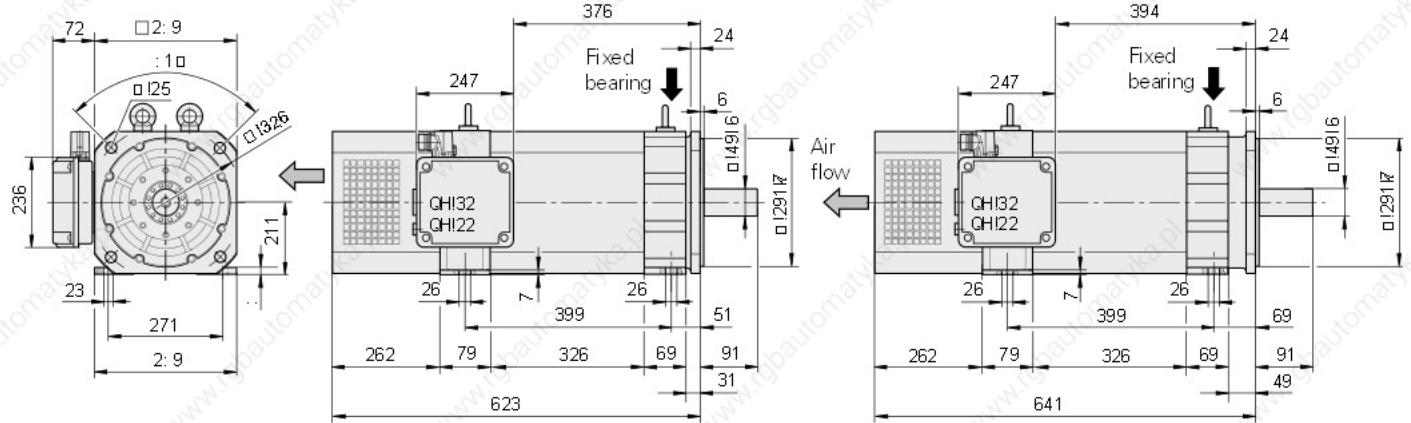

QAN 200U

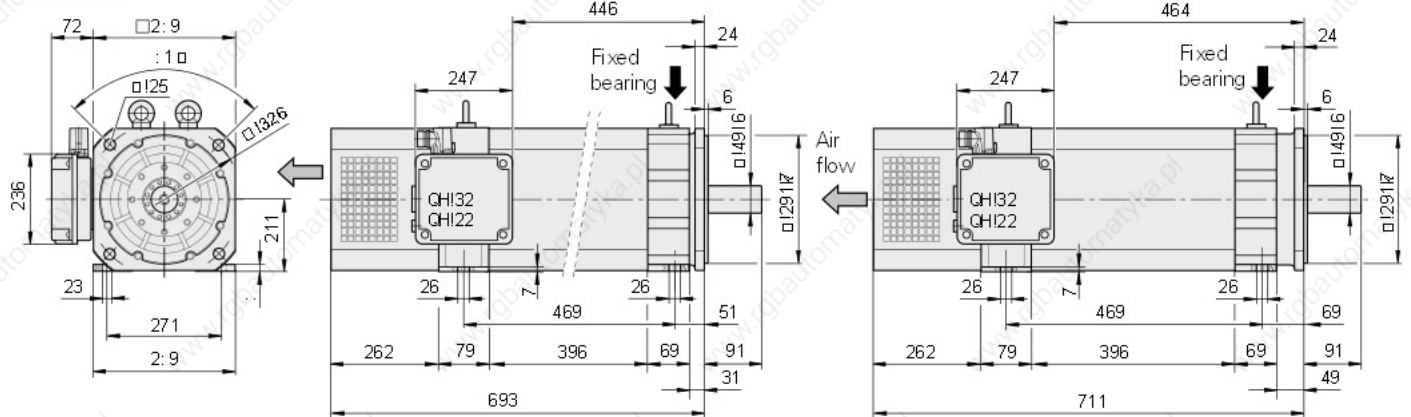

Asynchronous motors with stub shaft

QAN 260 series

Spindle motors with 2 pole pairs
 Rated power output 12 kW to 24 kW
 Choice of standard or spindle bearing



Motor	QAN 260M	QAN 260L	QAN 260U	QAN 260W
Rated voltage U_N	348 V	331 V	318 V	335 V
Rated power output P_N	15 kW	20 kW	24 kW	12 kW
Rated shaft speed n_N	1 500 min ⁻¹			750 min ⁻¹
Rated torque M_N (105 K)	96.0 Nm	128.0 Nm	153.0 Nm	153.0 Nm
Rated current I_N (105 K)	35.0 A	46.0 A	58.0 A	29.0 A
Efficiency	0.85			
Max. speed n_{max} ¹⁾ Standard bearing Spindle bearing*	8 000 min ⁻¹ 10 000 min ⁻¹ or 12 000 min ⁻¹		8 000 min ⁻¹ 10 000 min ⁻¹	
Max. current I_{max}	70 A	96 A	116 A	62 A
Weight m	112 kg	135 kg	158 kg	158 kg
Rotor inertia J	700 kgcm ²	920 kgcm ²	1 100 kgcm ²	1 100 kgcm ²
Protection	IP 54			
Fan Rated voltage U_L Rated current I_L Frequency f_L	3 x 400 V AC 0.19 A 50 Hz/60 Hz			
ID Motor with standard bearing Motor with spindle bearing 10 000 min ⁻¹ 12 000 min ⁻¹	510019-41 510019-53 510019-73	510020-41 510020-53 510020-73	510021-41 510021-53 -	510022-41 510022-53 -

¹⁾ The max. speed depends on the motor's application conditions, such as the shaft load (see the *Inverter Systems and Motors* Technical Manual).

* Please select when ordering

Rotatable connections

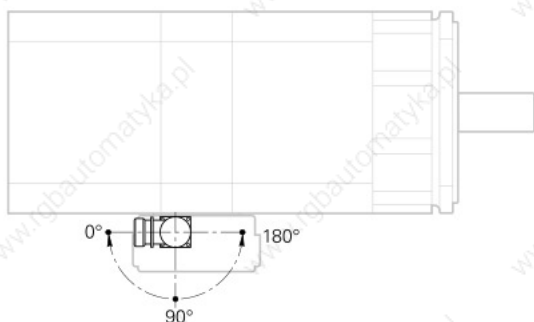

Encoder connector

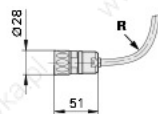

For R, see page 61

mm



Tolerancing ISO 8015

ISO 2768 - m H

< 6 mm: ±0.2 mm

QAN 260M

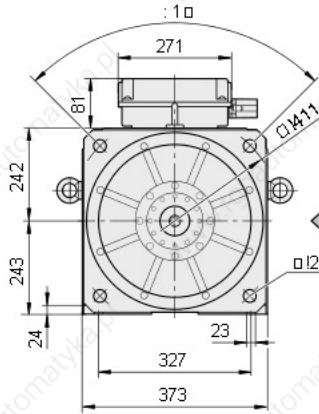

With standard bearing

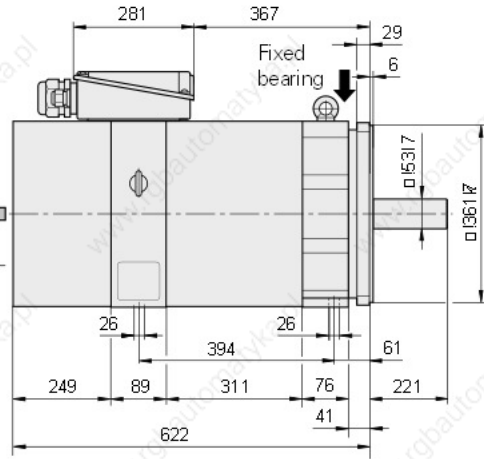

With spindle bearing

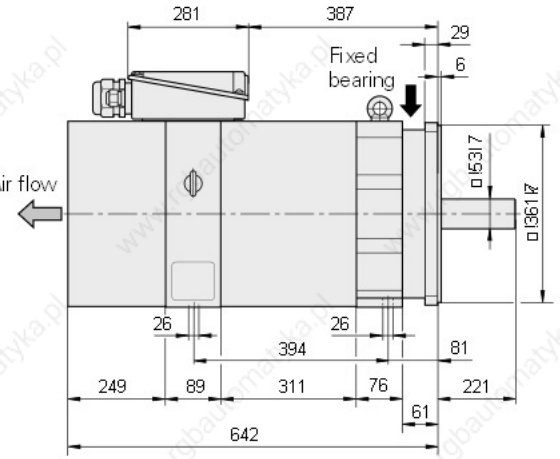

QAN 260L

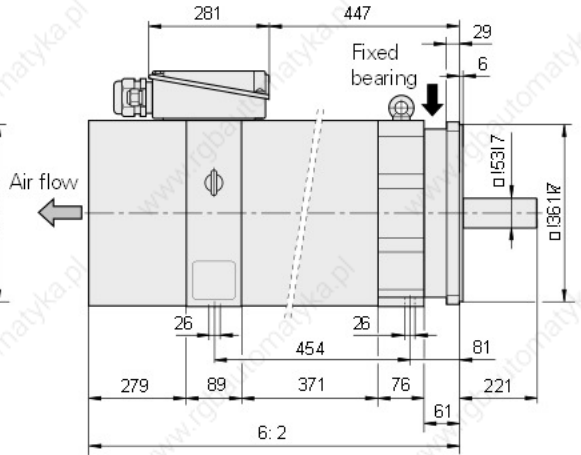
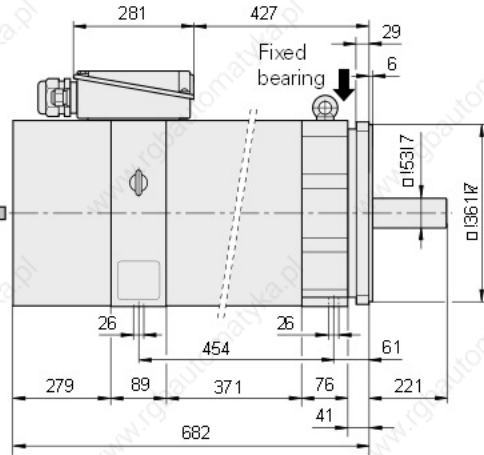
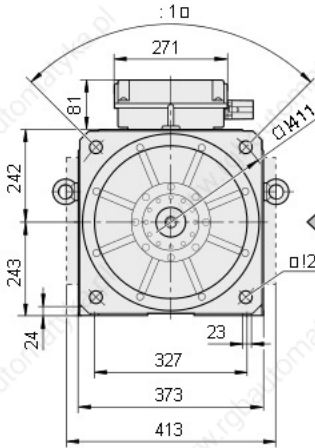

QAN 260U QAN 260W

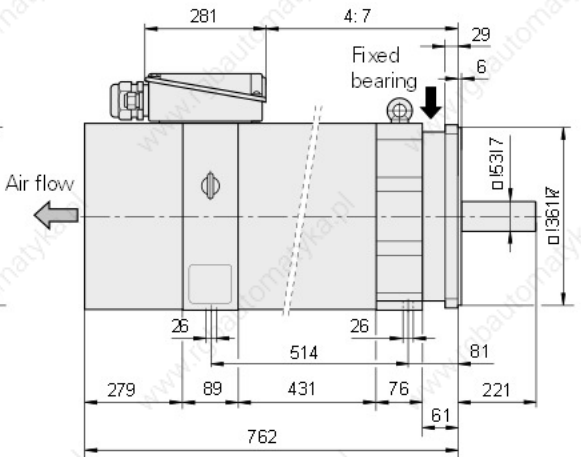
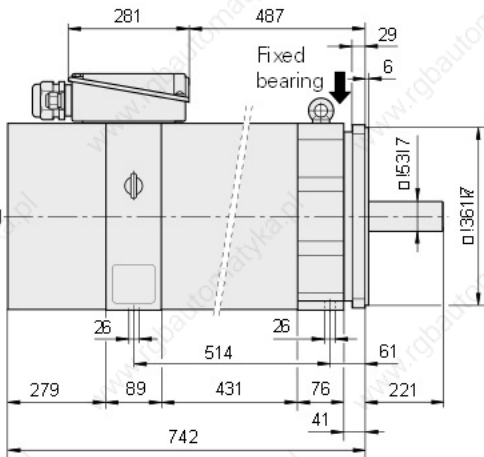
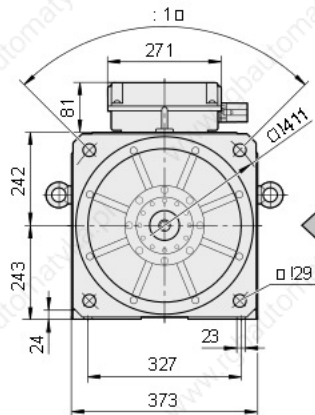

Asynchronous motors with stub shaft

QAN 320 series

Spindle motors with 2 pole pairs
Rated power output 18 kW to 40 kW



Motor	QAN 320M	QAN 320W	QAN 320L
Rated voltage U_N	317V	320V	315V
Rated power output P_N	32 kW	18 kW	40 kW
Rated shaft speed n_N	1 500 min ⁻¹	750 min ⁻¹	1 500 min ⁻¹
Rated torque M_N (105 K)	203.7 Nm	229.2 Nm	254.6 Nm
Rated current I_N (105 K)	77.5 A	43.0 A	99.0 A
Efficiency	0.85		0.91
Max. speed n_{max} ¹⁾ Standard bearing Spindle bearing	8 000 min ⁻¹ 10 000 min ⁻¹		
Max. current I_{max}	155 A	86 A	186 A
Weight m	240 kg		280 kg
Rotor inertia J	1 870 kgcm ²		2 300 kgcm ²
Fan Rated voltage U_L Rated current I_L Frequency f_L	3 x 400 V AC 0.6 A 50 Hz/60 Hz		
ID Motor with standard bearing Motor with spindle bearing	513302-01 513302-13	517952-01 517952-13	577484-01 577484-13

¹⁾ The max. speed depends on the motor's application conditions, such as the shaft load (see the *Inverter Systems and Motors* Technical Manual).

Rotatable connections

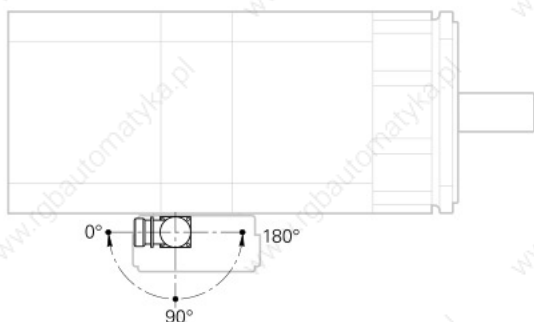

Encoder connector

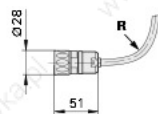

For R, see page 61

mm

 Tolerancing ISO 8015
 ISO 2768 - m H
 < 6 mm: ±0.2 mm

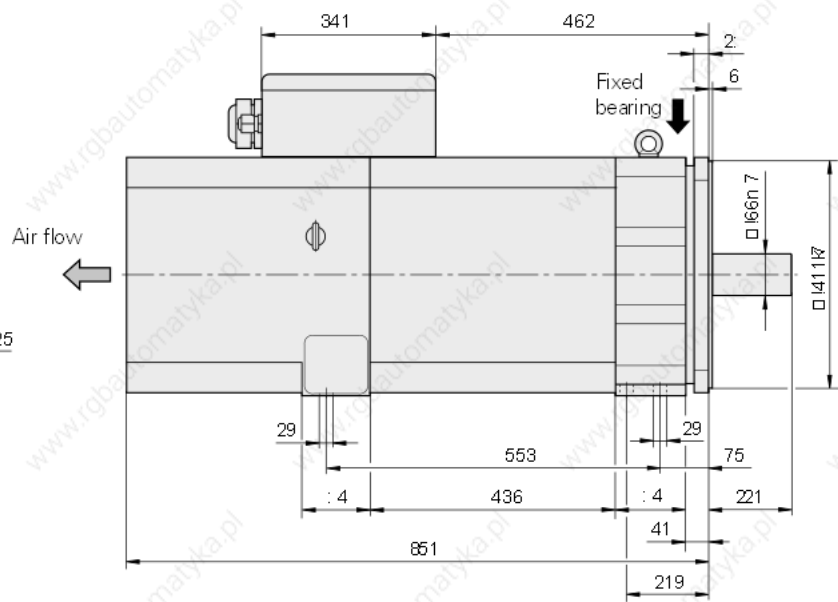
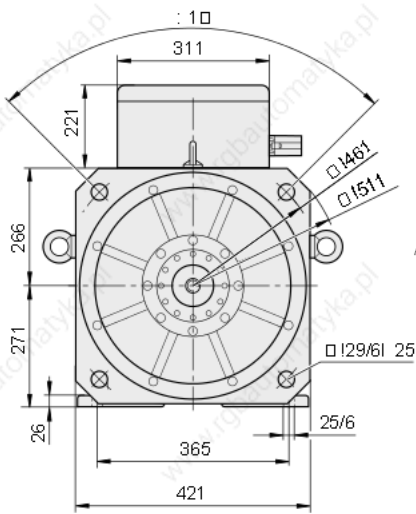
QAN 320M
QAN 320W

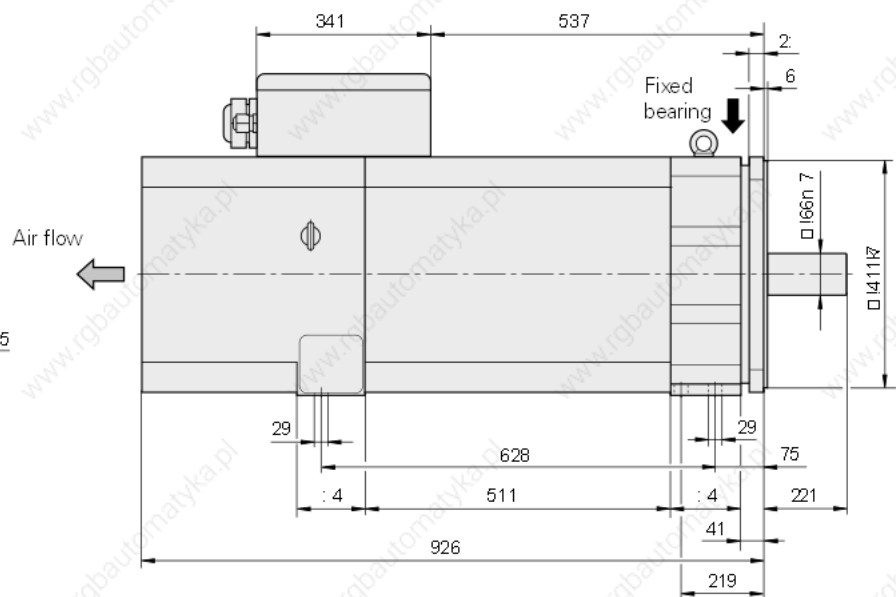
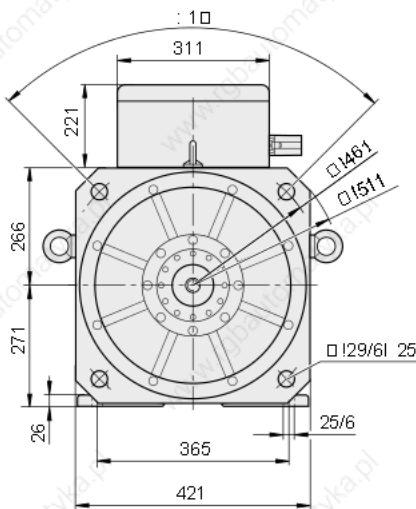

QAN 320L



Asynchronous motors with hollow shaft

QAN 200UH

Hollow-shaft spindle motor with 2 pole pairs
 Rated power output to 10 kW
 With spindle bearing



Motor	QAN 200UH	
Rated voltage U_N	330 V	
Rated power output P_N	10.0 kW	
Rated shaft speed n_N	1 500 min ⁻¹	
Rated torque M_N (105 K)	63.7 Nm	
Rated current I_N (105 K)	25.0 A	
Efficiency	0.85	
Max. speed $n_{max}^{1)}$ Spindle bearing	12 000 min ⁻¹	15 000 min ⁻¹
Max. current I_{max}	44 A	
Bore hole in shaft	□ 9 mm	
Weight m	91 kg	
Rotor inertia J	405 kgcm ²	
Protection	IP 54	
Fan Rated voltage U_L Rated current I_L Frequency f_L	3 x 400 V AC 0.2 A 50 Hz/60 Hz	
ID Motor with spindle bearing	536257-18	536257-43

¹⁾ The max. speed depends on the motor's application conditions, such as the shaft load (see the *Inverter Systems and Motors* Technical Manual).

Rotatable connections

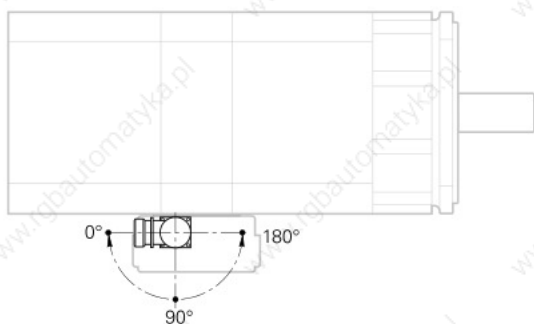

Encoder connector

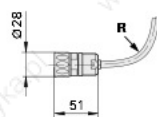

For R, see page 61

mm

 Tolerancing ISO 8015
 ISO 2768 - m H
 < 6 mm: ±0.2 mm

QAN 200UH 12 000 min⁻¹

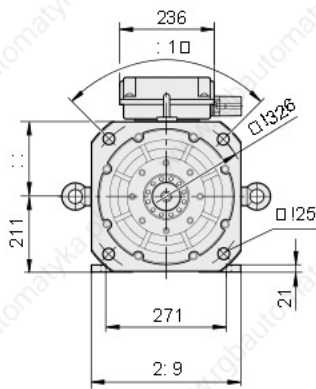

With spindle bearing

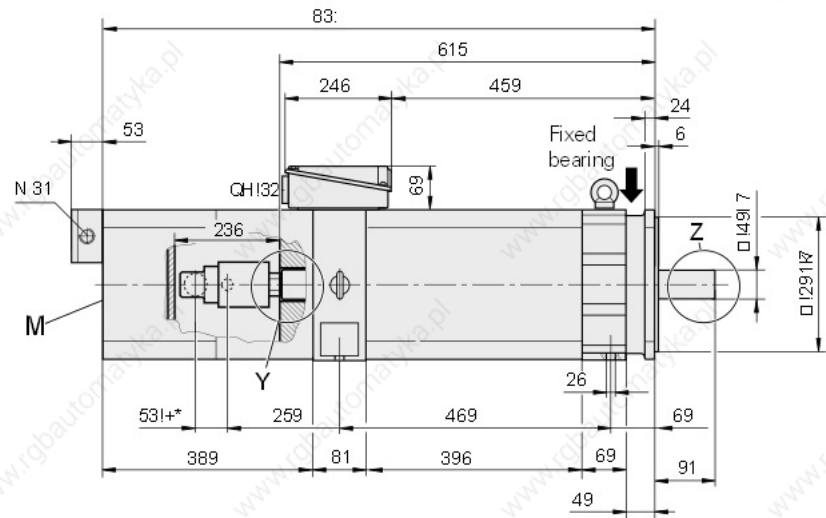

QAN 200UH 15 000 min⁻¹

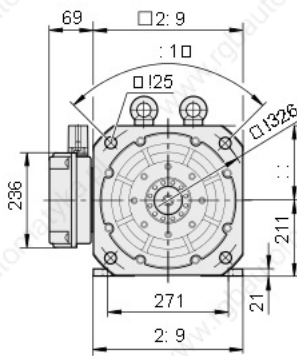

With spindle bearing

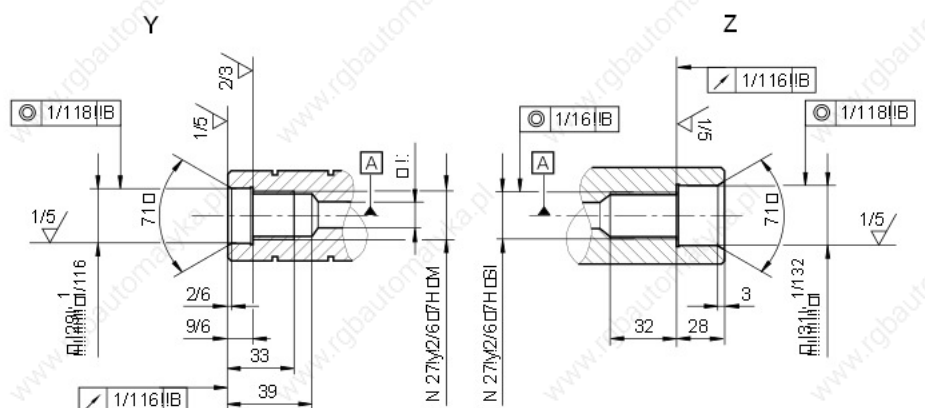
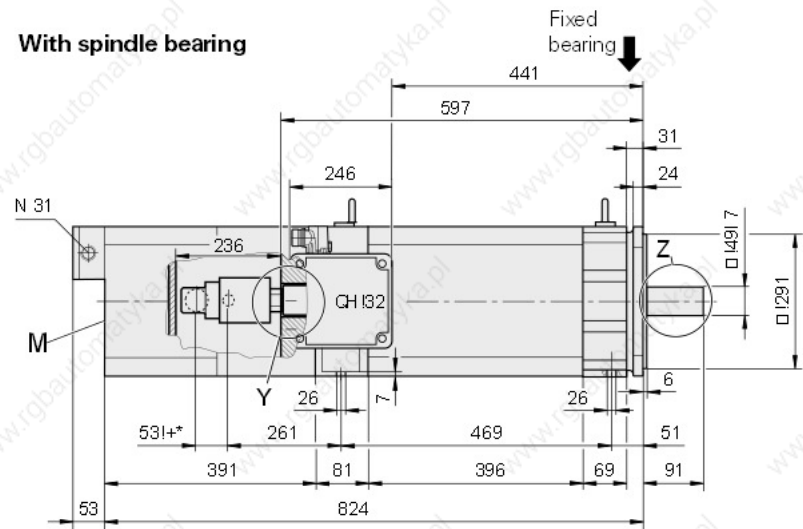

 = Air outlet at the rear

***)** = Coolant connection on the right side, e.g. from Deublin 1109-020-188

Asynchronous motors with hollow shaft

QAN 260xH series

Hollow-shaft spindle motor with 2 pole pairs
 Rated power output 15 kW to 22 kW
 With spindle bearing



Motor	QAN 260MH	QAN 260LH	QAN 260UH
Rated voltage U_N	348 V	331 V	318 V
Rated power output P_N	15 kW	20 kW	22 kW
Rated shaft speed n_N	1 500 min^{-1}		
Rated torque M_N (105 K)	96.0 Nm	128.0 Nm	140.0 Nm
Rated current I_N (105 K)	35.0 A	46.0 A	54.0 A
Efficiency	0.85		
Max. speed $n_{\text{max}}^{1)}$ Spindle bearing*	12 000 min^{-1}		10 000 min^{-1} or 12 000 min^{-1}
Max. current I_{max}	70 A	96 A	116 A
Weight m	120 kg	143 kg	158 kg
Rotor inertia J	700 kgcm^2	920 kgcm^2	1 100 kgcm^2
Protection	IP 54		
Fan Rated voltage U_L Rated current I_L Frequency f_L	3 x 400 V AC 0.19 A 50 Hz/60 Hz		
ID Motor with spindle bearing			
10 000 min^{-1}	–	–	536259-53
12 000 min^{-1}	642855-73	631449-73	536259-73

¹⁾ The max. speed depends on the motor's application conditions, such as the shaft load (see the *Inverter Systems and Motors* Technical Manual).

* Please select when ordering

Rotatable connections

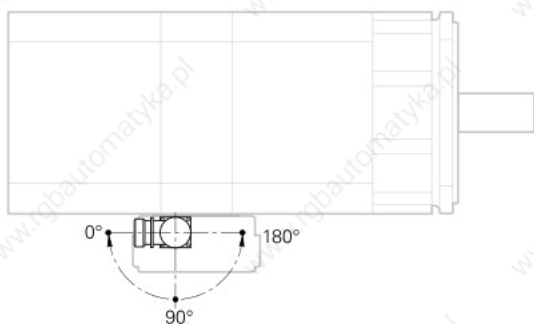

Encoder connector

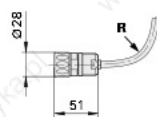

For R, see page 61

QAN 260MH

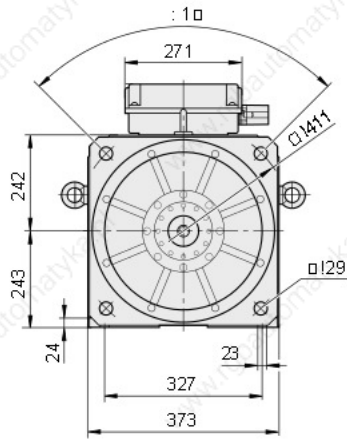

With spindle bearing

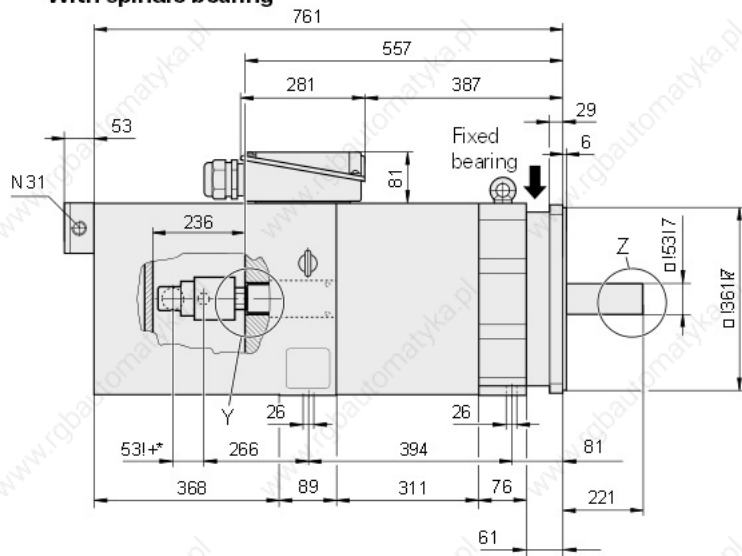

QAN 260LH

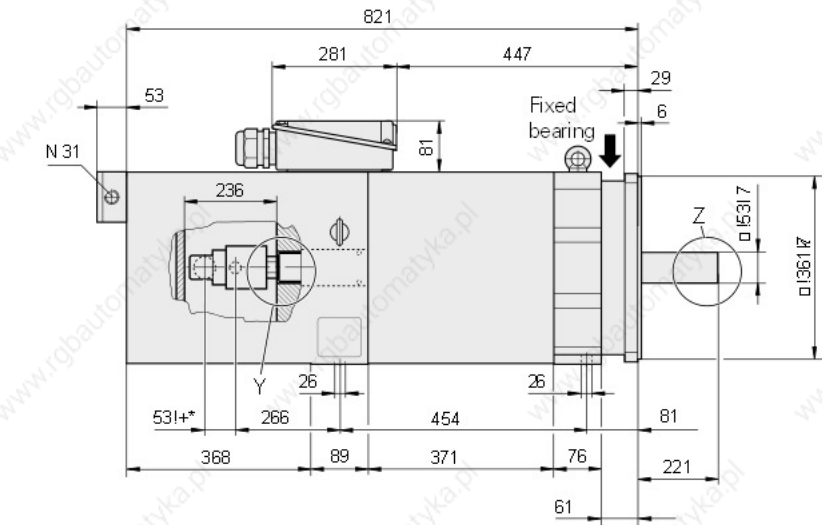
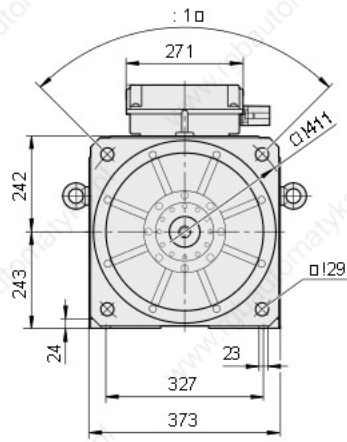

QAN 260UH

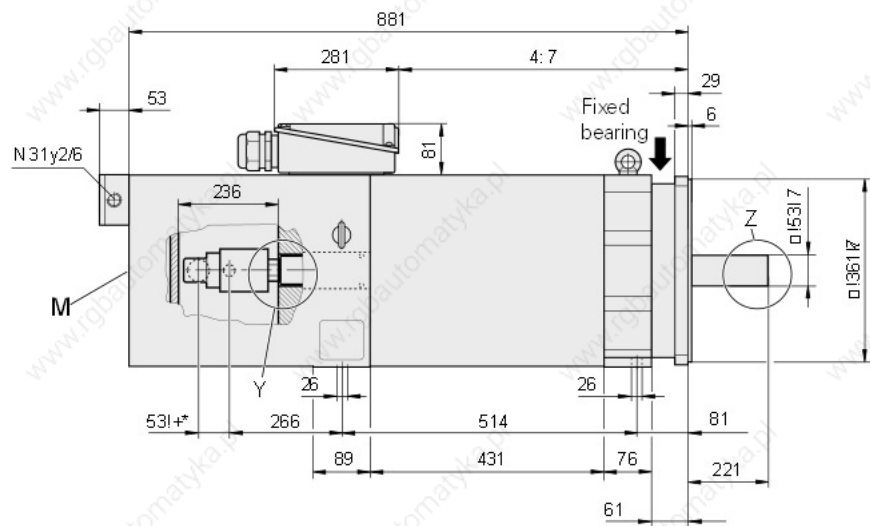
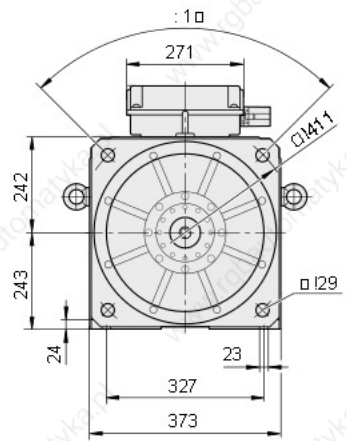

mm
 Tolerancing ISO 8015
 ISO 2768 - m H
 < 6 mm: ±0.2 mm

□ = Air outlet on both sides

*) = Coolant connection on the right side, e.g. from Deublin 1109-020-188

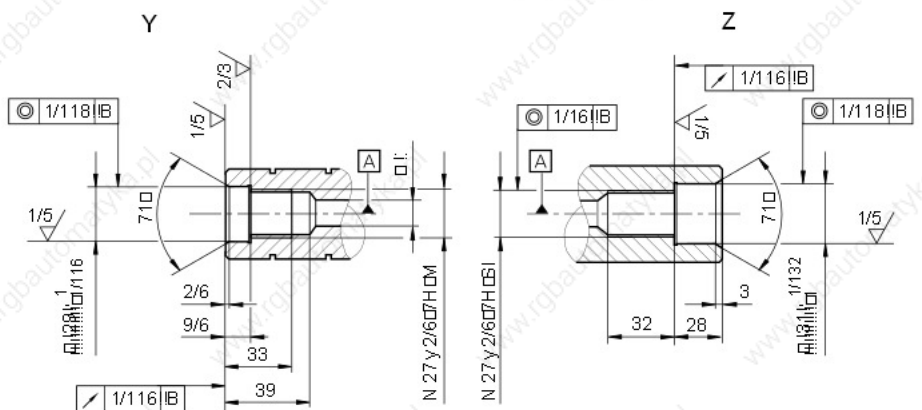

Asynchronous motors

Characteristics of power and torque

QAN 200M

Duty cycle	Speed n	Power P	Torque M	Current I
S1	1 500 min ⁻¹	5.5 kW	35.0 Nm	18.0 A
	6 000 min ⁻¹	5.5 kW	8.8 Nm	–
	12 000 min ⁻¹	5.5 kW	4.4 Nm	–
S6-60%	1 500 min ⁻¹	7.0 kW	44.7 Nm	22.0 A
	6 000 min ⁻¹	7.0 kW	11.2 Nm	–
	12 000 min ⁻¹	7.0 kW	5.6 Nm	–
S6-40%	1 500 min ⁻¹	7.9 kW	50.4 Nm	24.0 A
	6 000 min ⁻¹	7.9 kW	12.6 Nm	–
	12 000 min ⁻¹	7.9 kW	6.3 Nm	–
S6-25%	1 500 min ⁻¹	9.5 kW	60.7 Nm	28.0 A
	6 000 min ⁻¹	9.5 kW	15.2 Nm	–
	12 000 min ⁻¹	9.5 kW	7.6 Nm	–

Power characteristic curve

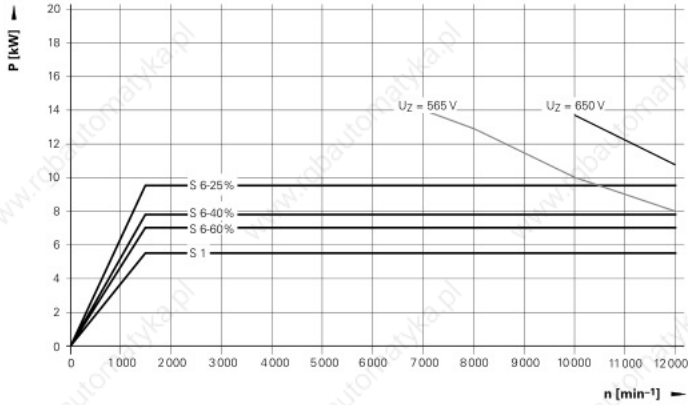

Torque characteristic curve

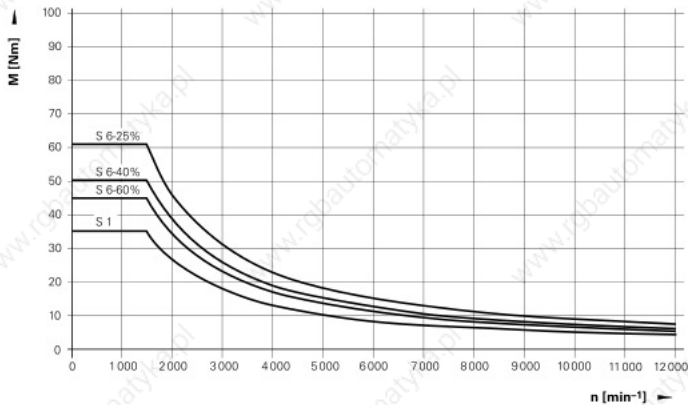

QAN 200L

Duty cycle	Speed n	Power P	Torque M	Current I
S1	1 500 min ⁻¹	7.5 kW	478 Nm	20.1 A
	6 000 min ⁻¹	7.5 kW	12.0 Nm	–
	12 000 min ⁻¹	7.5 kW	6.0 Nm	–
S6-60%	1 500 min ⁻¹	9.8 kW	62.6 Nm	24.0 A
	10 700 min ⁻¹	9.8 kW	9.5 Nm	–
	12 000 min ⁻¹	8.5 kW	6.8 Nm	–
S6-40%	1 500 min ⁻¹	11.5 kW	73.4 Nm	27.0 A
	9 000 min ⁻¹	11.5 kW	11.0 Nm	–
	12 000 min ⁻¹	8.5 kW	6.8 Nm	–
S6-25%	1 500 min ⁻¹	13.0 kW	83.0 Nm	31.0 A
	7 500 min ⁻¹	13.0 kW	16.6 Nm	–
	12 000 min ⁻¹	8.5 kW	6.8 Nm	–

Power characteristic curve

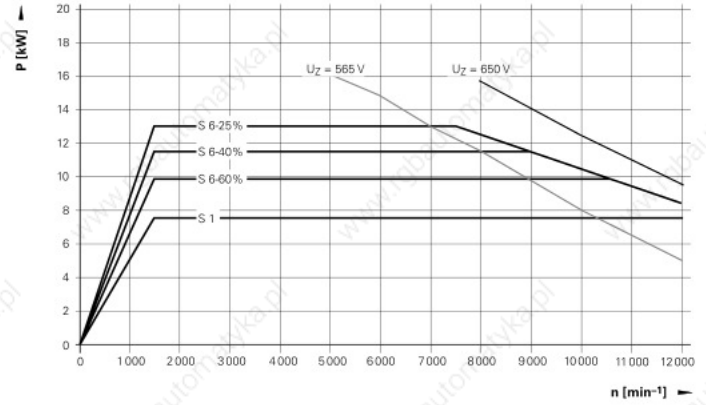

Torque characteristic curve

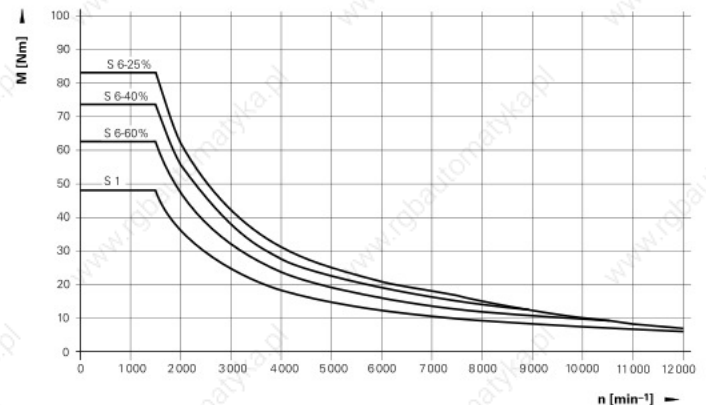

Note

s S6 mode

Cycle duration 10 min.
In the rest period the motor is idle.

QAN 200U

Duty cycle	Speed n	Power P	Torque M	Current I
S1	1 500 min ⁻¹	10.0 kW	63.7 Nm	25.0 A
	10 000 min ⁻¹	10.0 kW	9.5 Nm	–
	12 000 min ⁻¹	8.0 kW	6.4 Nm	–
S6-60%	1 500 min ⁻¹	12.5 kW	79.8 Nm	29.0 A
	10 000 min ⁻¹	12.5 kW	11.9 Nm	–
	12 000 min ⁻¹	10.0 kW	8.0 Nm	–
S6-40%	1 500 min ⁻¹	14.0 kW	89.4 Nm	32.0 A
	9 000 min ⁻¹	14.0 kW	19.1 Nm	–
	12 000 min ⁻¹	11.0 kW	8.8 Nm	–
S6-25%	1 500 min ⁻¹	17.0 kW	108.6 Nm	37.0 A
	7 500 min ⁻¹	17.0 kW	21.7 Nm	–
	12 000 min ⁻¹	12.0 kW	9.5 Nm	–

Power characteristic curve

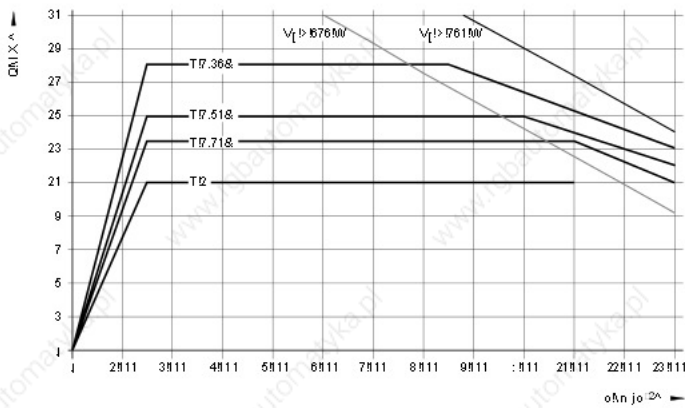

Torque characteristic curve

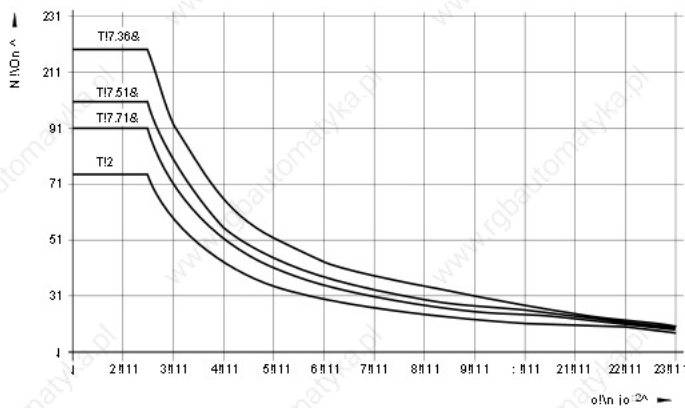

QAN 200UH

Duty cycle	Speed n	Power P	Torque M	Current I
S1	1 500 min ⁻¹	10.0 kW	63.7 Nm	25.0 A
	10 000 min ⁻¹	10.0 kW	9.5 Nm	–
	12 000 min ⁻¹	8.0 kW	6.4 Nm	–
	15 000 min ⁻¹	4.0 kW	2.5 Nm	–
S6-60%	1 500 min ⁻¹	12.5 kW	79.8 Nm	29.0 A
	10 000 min ⁻¹	12.5 kW	11.9 Nm	–
	12 000 min ⁻¹	10.0 kW	8.0 Nm	–
	15 000 min ⁻¹	5.0 kW	3.2 Nm	–
S6-40%	1 500 min ⁻¹	14.0 kW	89.4 Nm	32.0 A
	9 000 min ⁻¹	14.0 kW	19.1 Nm	–
	12 000 min ⁻¹	11.0 kW	8.8 Nm	–
	15 000 min ⁻¹	6.0 kW	3.8 Nm	–
S6-25%	1 500 min ⁻¹	17.0 kW	108.6 Nm	37.0 A
	7 500 min ⁻¹	17.0 kW	21.7 Nm	–
	12 000 min ⁻¹	12.0 kW	9.5 Nm	–
	15 000 min ⁻¹	7.0 kW	4.5 Nm	–

Power characteristic curve

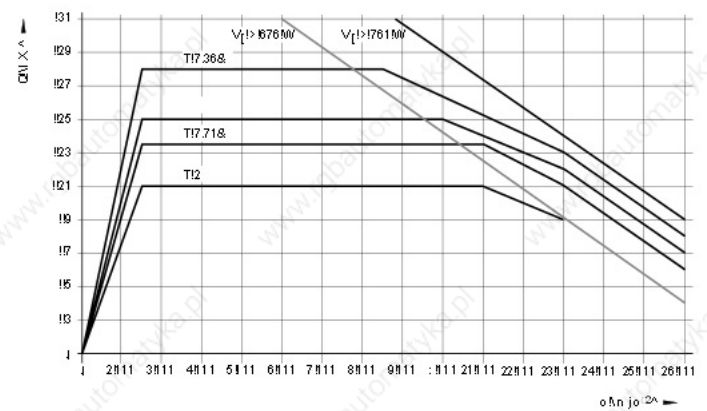

Torque characteristic curve

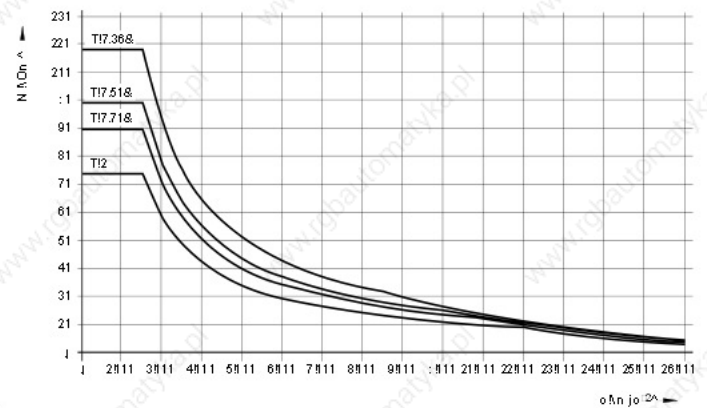

QAN 260M, QAN 260MH

Duty cycle	Speed n	Power P	Torque M	Current I
S1	1 500 min ⁻¹	15.0 kW	95.5 Nm	35.0 A
	6 500 min ⁻¹	15.0 kW	22.0 Nm	–
	10 000 min ⁻¹	10.0 kW	9.5 Nm	–
	12 000 min ⁻¹	4.0 kW	3.2 Nm	–
S6-60%	1 500 min ⁻¹	20.0 kW	1273 Nm	43.3 A
	5 000 min ⁻¹	20.0 kW	38.2 Nm	–
	9 000 min ⁻¹	13.5 kW	14.3 Nm	–
S6-40%	1 500 min ⁻¹	25.0 kW	159.2 Nm	52.3 A
	4 500 min ⁻¹	25.0 kW	53.1 Nm	–
	8 000 min ⁻¹	16.8 kW	20.1 Nm	–
S6-25%	1 500 min ⁻¹	32.0 kW	203.7 Nm	65.0 A
	4 000 min ⁻¹	32.0 kW	76.4 Nm	–
	6 000 min ⁻¹	23.7 kW	37.7 Nm	–

Power characteristic curve

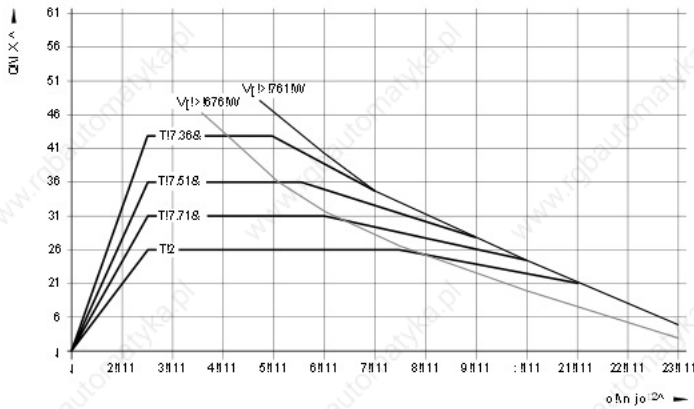

Torque characteristic curve

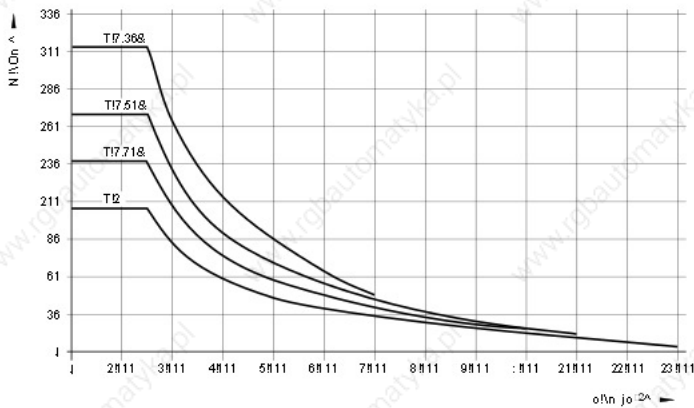

QAN 260L, QAN 260LH

Duty cycle	Speed n	Power P	Torque M	Current I
S1	1 500 min ⁻¹	20.0 kW	1273 Nm	46.0 A
	6 500 min ⁻¹	20.0 kW	29.4 Nm	–
	10 000 min ⁻¹	13.0 kW	12.4 Nm	–
	12 000 min ⁻¹	8.0 kW	6.4 Nm	–
S6-60%	1 500 min ⁻¹	25.0 kW	159.2 Nm	56.0 A
	6 000 min ⁻¹	25.0 kW	39.4 Nm	–
	10 000 min ⁻¹	16.0 kW	15.3 Nm	–
	12 000 min ⁻¹	8.0 kW	6.4 Nm	–
S6-40%	1 500 min ⁻¹	30.0 kW	191.0 Nm	65.0 A
	5 500 min ⁻¹	30.0 kW	52.1 Nm	–
	10 000 min ⁻¹	17.5 kW	16.7 Nm	–
S6-25%	1 500 min ⁻¹	37.0 kW	235.5 Nm	79.0 A
	5 000 min ⁻¹	37.0 kW	70.7 Nm	–
	8 000 min ⁻¹	24.0 kW	28.6 Nm	–

Power characteristic curve

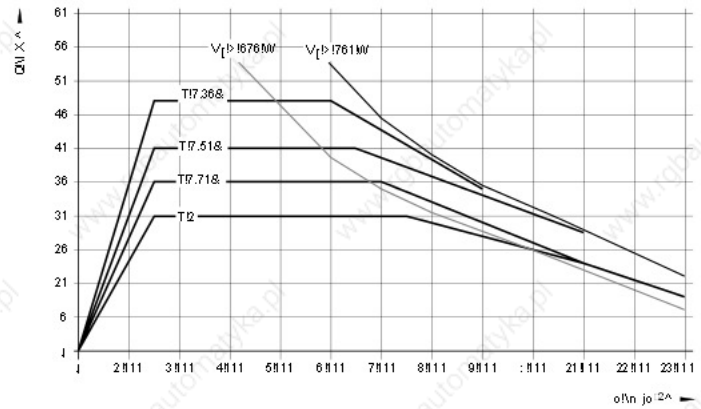

Torque characteristic curve

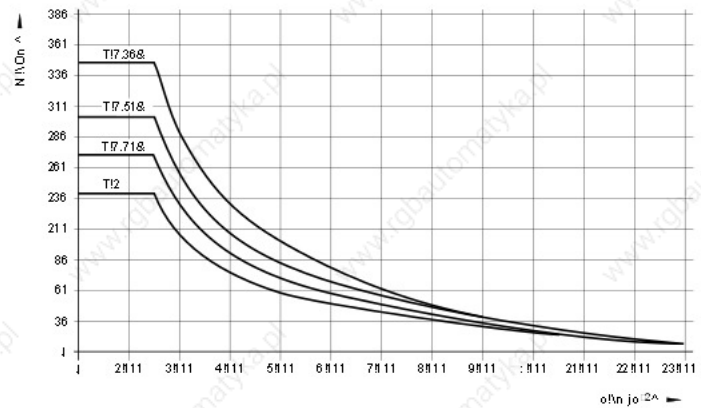

QAN 260U

Duty cycle	Speed n	Power P	Torque M	Current I
S1	1 500 min ⁻¹	24.0 kW	152.8 Nm	58.0 A
	7 400 min ⁻¹	24.0 kW	31.0 Nm	–
	10 000 min ⁻¹	18.0 kW	172 Nm	–
S6-60%	1 500 min ⁻¹	30.0 kW	191.0 Nm	67.2 A
	7 000 min ⁻¹	30.0 kW	40.9 Nm	–
	10 000 min ⁻¹	22.5 kW	21.5 Nm	–
S6-40%	1 500 min ⁻¹	38.0 kW	241.9 Nm	81.8 A
	5 500 min ⁻¹	38.0 kW	66.0 Nm	–
	10 000 min ⁻¹	26.0 kW	24.8 Nm	–
S6-25%	1 500 min ⁻¹	48.0 kW	305.6 Nm	100.6 A
	4 500 min ⁻¹	48.0 kW	101.9 Nm	–
	7 000 min ⁻¹	41.0 kW	55.9 Nm	–

Power characteristic curve

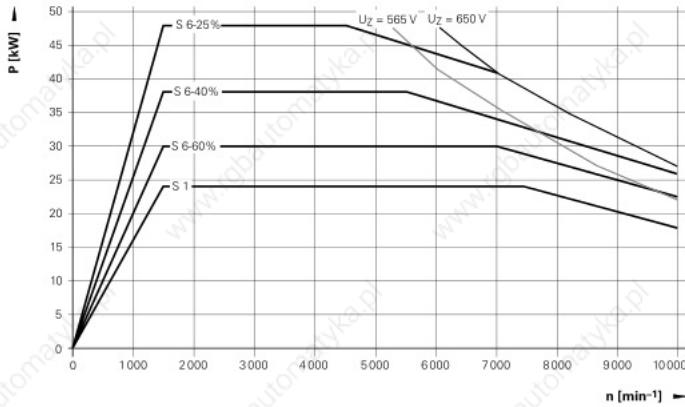

Torque characteristic curve

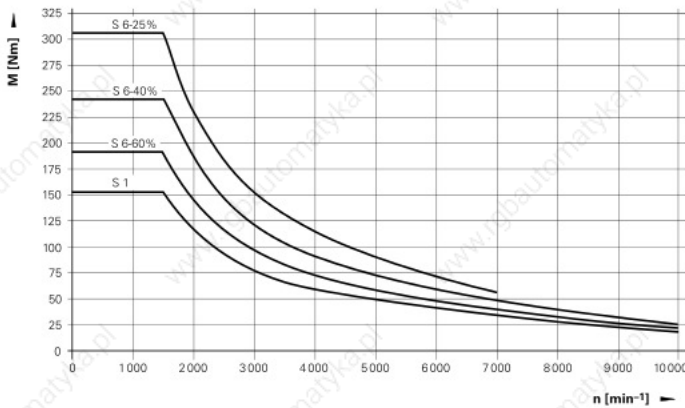

QAN 260UH

Duty cycle	Speed n	Power P	Torque M	Current I
S1	1 500 min ⁻¹	22.0 kW	140.1 Nm	54.0 A
	7 400 min ⁻¹	22.0 kW	28.4 Nm	–
	10 000 min ⁻¹	16.0 kW	15.3 Nm	–
S6-60%	1 500 min ⁻¹	30.0 kW	191.0 Nm	67.0 A
	6 500 min ⁻¹	30.0 kW	44.1 Nm	–
	10 000 min ⁻¹	20.0 kW	19.5 Nm	–
S6-40%	1 500 min ⁻¹	35.0 kW	222.8 Nm	77.0 A
	6 500 min ⁻¹	35.0 kW	66.8 Nm	–
	10 000 min ⁻¹	24.0 kW	22.9 Nm	–
S6-25%	1 500 min ⁻¹	46.0 kW	286.5 Nm	97.0 A
	5 000 min ⁻¹	46.0 kW	85.9 Nm	–
	10 000 min ⁻¹	27.0 kW	25.8 Nm	–

Power characteristic curve

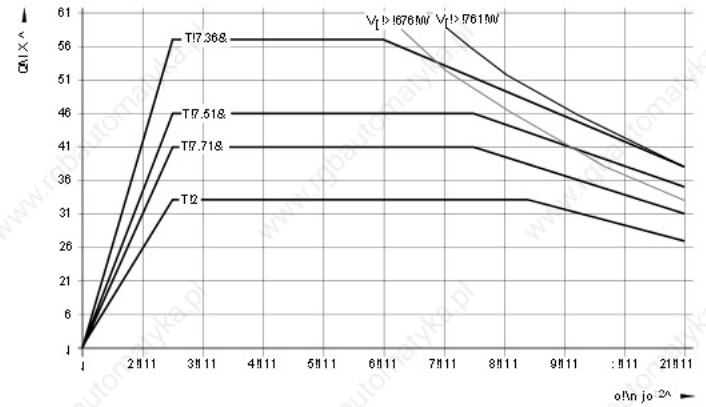

Torque characteristic curve

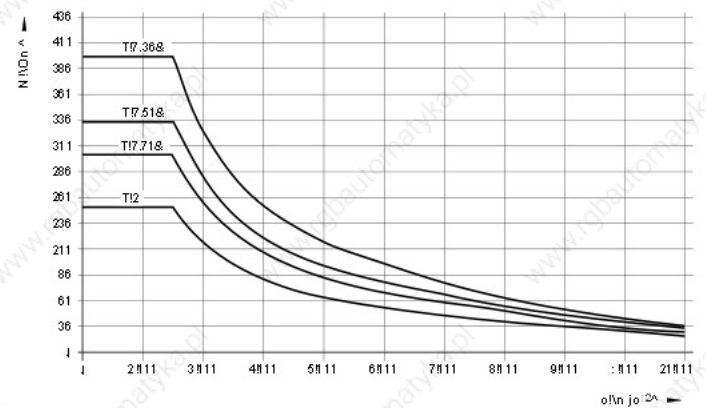

QAN 260 W

Duty cycle	Speed n	Power P	Torque M	Current I
S1	750 min ⁻¹	12.0 kW	152.8 Nm	29.0 A
	5000 min ⁻¹	12.0 kW	22.9 Nm	–
	10000 min ⁻¹	4.0 kW	3.8 Nm	–
S6-60%	750 min ⁻¹	175 kW	222.8 Nm	38.1 A
	3000 min ⁻¹	175 kW	55.7 Nm	–
	6000 min ⁻¹	11.3 kW	18.0 Nm	–
S6-40%	750 min ⁻¹	22.0 kW	280.1 Nm	46.4 A
	2500 min ⁻¹	22.0 kW	84.0 Nm	–
	3500 min ⁻¹	19.0 kW	51.8 Nm	–

Power characteristic curve

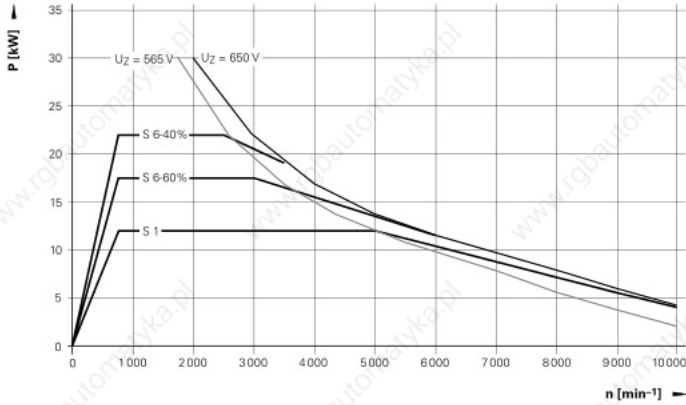

Torque characteristic curve

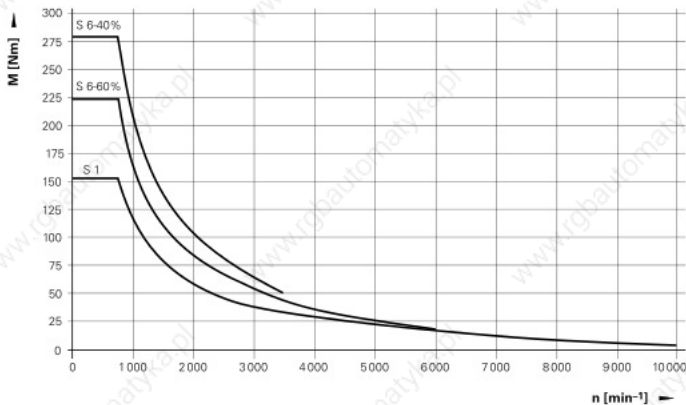

QAN 320 M

Duty cycle	Speed n	Power P	Torque M	Current I
S1	1500 min ⁻¹	32.0 kW	203.7 Nm	77.5 A
	5500 min ⁻¹	32.0 kW	55.0 Nm	–
	10000 min ⁻¹	19.5 kW	18.6 Nm	–
S6-60%	1500 min ⁻¹	43.0 kW	273.7 Nm	98.0 A
	5500 min ⁻¹	43.0 kW	71.5 Nm	–
	10000 min ⁻¹	25.0 kW	23.9 Nm	–
S6-40%	1500 min ⁻¹	53.0 kW	337.4 Nm	118.0 A
	5500 min ⁻¹	53.0 kW	86.2 Nm	–
	6000 min ⁻¹	48.0 kW	76.4 Nm	–

Power characteristic curve

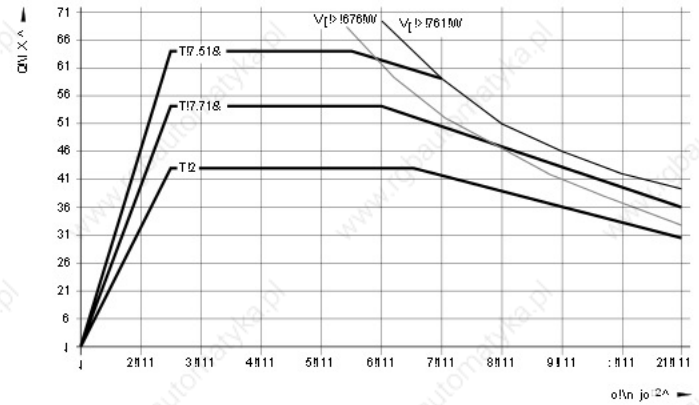

Torque characteristic curve

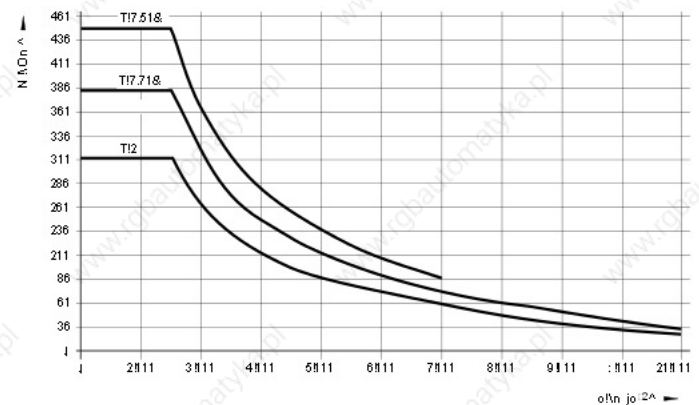

QAN 320L

Duty cycle	Speed n	Power P	Torque M	Current I
S1	1 500 min ⁻¹	40.0 kW	254.6 Nm	99.0 A
	5 000 min ⁻¹	40.0 kW	77.9 Nm	–
	10 000 min ⁻¹	21.0 kW	21.0 Nm	–
S6-60%	1 500 min ⁻¹	53.0 kW	337.4 Nm	123.0 A
	4 500 min ⁻¹	53.0 kW	112.5 Nm	–
	10 000 min ⁻¹	24.0 kW	22.9 Nm	–
S6-40%	1 500 min ⁻¹	66.0 kW	420.2 Nm	148.0 A
	4 500 min ⁻¹	66.0 kW	140.1 Nm	–
	10 000 min ⁻¹	28.0 kW	26.7 Nm	–

Power characteristic curve

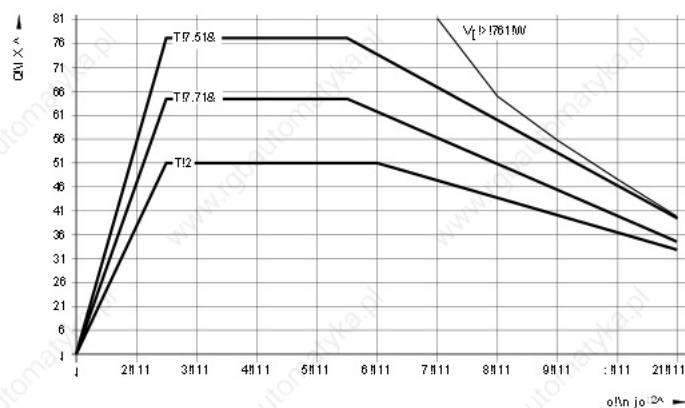

Torque characteristic curve

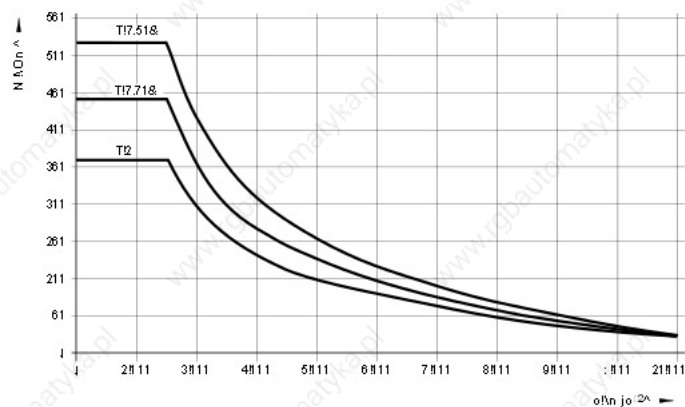

QAN 320W

Duty cycle	Speed n	Power P	Torque M	Current I
S1	750 min ⁻¹	18.0 kW	229.2 Nm	43.0 A
	3500 min ⁻¹	18.0 kW	49.1 Nm	–
	10 000 min ⁻¹	5.0 kW	4.8 Nm	–
S6-60%	750 min ⁻¹	24.0 kW	305.6 Nm	54.0 A
	2000 min ⁻¹	24.0 kW	114.6 Nm	–
	4000 min ⁻¹	18.5 kW	44.2 Nm	–
S6-40%	750 min ⁻¹	30.0 kW	382.0 Nm	71.0 A
	2000 min ⁻¹	30.0 kW	143.2 Nm	–
	3000 min ⁻¹	25.0 kW	79.6 Nm	–

Power characteristic curve

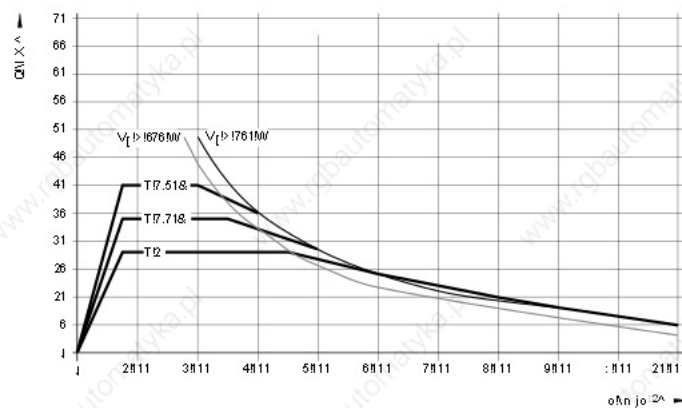

Torque characteristic curve

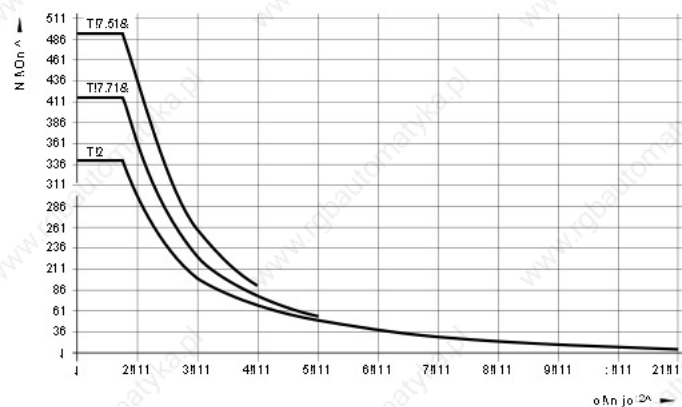

Asynchronous motors

Cables

Power cables

Current load at ambient temperature up to 40 °C

	Cable without connectors ID	Bend radius R for frequent flexing	Cable type	Diameter
Current load up to 26 A (installation type B2)				
QAN 200M QAN 200L QAN 200U QAN 200UH	348949-04	□ 70 mm	PUR [4 x 4 mm ²]	14.1 mm
Current load up to 32.8 A (installation type B2)				
QAN 260W	348949-05	□ 75 mm	PUR [4 x 6 mm ²]	15.6 mm
Current load up to 45.2 A (installation type B2)				
QAN 260M QAN 260MH QAN 320W	348949-06		PUR [4 x 10 mm ²]	20.3 mm
Current load up to 59.9 A (installation type B2)				
QAN 260L QAN 260LH QAN 260U QAN 260UH	348949-07	□ 135 mm	PUR [4 x 16 mm ²]	27.3 mm
Current load up to 93.8 A (installation type B2)				
QAN 320M	348949-09	□ 175 mm	PUR [4 x 35 mm ²]	35.5 mm
Current load up to 117.5 A (installation types C and E)				
QAN 320L	348949-09	□ 175 mm	PUR [4 x 35 mm ²]	35.5 mm

Encoder cables

	Cable length	Cable complete with connectors ID	Line drop compensator ID	Extension cable ID	Bend radius R for frequent flexing
All QAN	< 30 m	289440-xx	–	336847-xx (as required)	□ 100 mm
	> 30 m	289440-xx	370226-01	336847-xx	

Cables for fans

	Cable without connectors ID	Bend radius R for frequent flexing	Cable type	Diameter
All QAN	348949-01	□ 50 mm	PUR [4 x 0.75 mm ²]	10 mm

Accessories

Toroidal cores

With large line lengths, voltage peaks that may damage the motor can occur. For this reason, toroidal cores need to be used in motor lines with lengths greater than 15 m. One toroidal core is required per phase. The toroidal cores must be located close to the inverter (max. 2 m).

Toroidal core

For motor line > 15 m
ID 827054-01

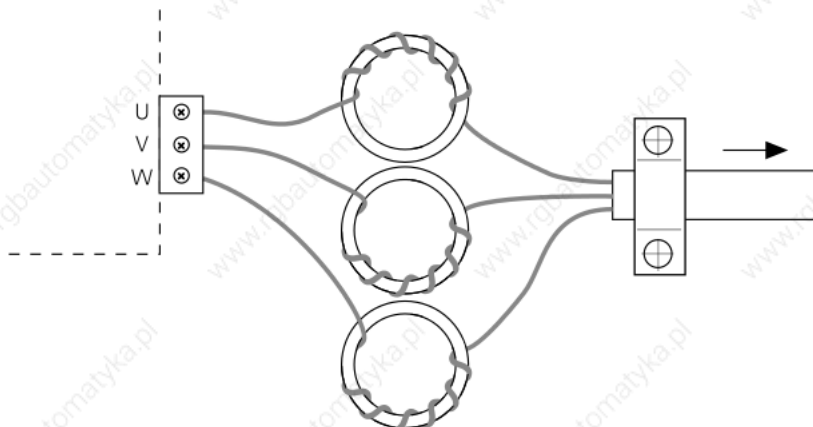

Dimensions

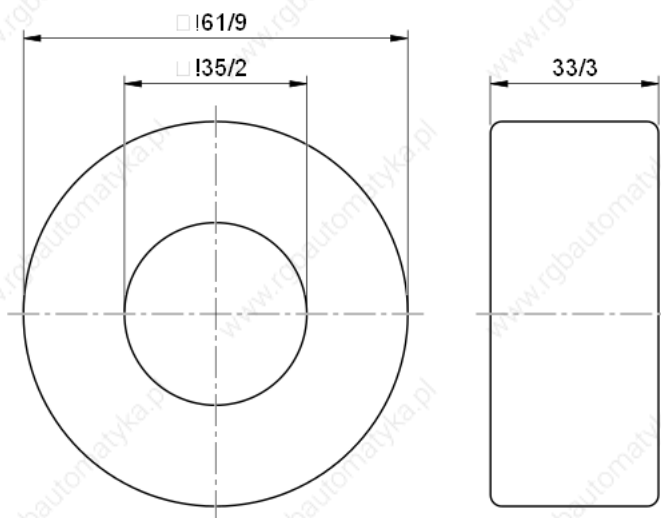

mm

Tolerancing ISO 8015
ISO 2768 - m H
< 6 mm: ± 0.2 mm

HEIDENHAIN

ES/IKPI BOOFTII F.EFOI B.DIHn cl
 Es/ kpi boof t .l f jef oi bjo.TusbDf l6
 94412!Uobv of v u!Hf sn boz
 | , 5: 1977: 142.1
 } , 5: 1977: 16172
 F.n bjrtjogpAi f jef oi bjo/ef

x x x /i f jef oi bjo/ef

Vollständige und weitere Adressen siehe www.heidenhain.de
 For complete and further addresses see www.heidenhain.de

DE	HEIDENHAIN Vertrieb Deutschland 83301 Traunreut, Deutschland ☐ 08669 31-3132 08669 32-3132 EMail: hd@heidenhain.de HEIDENHAIN Technisches Büro Nord 12681 Berlin, Deutschland ☐ 030 54705-240 HEIDENHAIN Technisches Büro Mitte 07751 Jena, Deutschland ☐ 03641 4728-250 HEIDENHAIN Technisches Büro West 44379 Dortmund, Deutschland ☐ 0231 618083-0 HEIDENHAIN Technisches Büro Südwest 70771 Leinfelden-Echterdingen, Deutschland ☐ 0711 993395-0 HEIDENHAIN Technisches Büro Südost 83301 Traunreut, Deutschland ☐ 08669 31-1345	ES	FARRESA ELECTRONICA S.A. 08028 Barcelona, Spain www.farresa.es	PL	APS 02-384 Warszawa, Poland www.heidenhain.pl
		FI	HEIDENHAIN Scandinavia AB 02770 Espoo, Finland www.heidenhain.fi	PT	FARRESA ELECTRONICA, LDA. 4470 - 177 Maia, Portugal www.farresa.pt
		FR	HEIDENHAIN FRANCE sarl 92310 Sures, France www.heidenhain.fr	RO	HEIDENHAIN Reprezentanta Romania Brasov, 500407, Romania www.heidenhain.ro
		GB	HEIDENHAIN (G.B.) Limited Burgess Hill RH15 9RD, United Kingdom www.heidenhain.co.uk	RS	Serbia ☐ BG
		GR	MB Milionis Vassilis 17341 Athens, Greece www.heidenhain.gr	RU	OOO HEIDENHAIN 125315 Moscow, Russia www.heidenhain.ru
		HK	HEIDENHAIN LTD Kowloon, Hong Kong E-mail: sales@heidenhain.com.hk	SE	HEIDENHAIN Scandinavia AB 12739 Sköholmen, Sweden www.heidenhain.se
		HR	Croatia ☐ SL	SG	HEIDENHAIN PACIFIC PTE.LTD. Singapore 408593 www.heidenhain.com.sg
		HU	HEIDENHAIN Kereskedelmi Köpvelet 1239 Budapest, Hungary www.heidenhain.hu	SK	KOPRETINA TN s.r.o. 91101 Trenčín, Slovakia www.kopretina.sk
AR	NAKASE SRL B1653AOX Villa Ballester, Argentina www.heidenhain.com.ar	ID	PT Servitama Era Toolsindo Jakarta 13930, Indonesia E-mail: ptset@group.gts.co.id	SL	NAVO d.o.o. 2000 Maribor, Slovenia www.heidenhain.si
AT	HEIDENHAIN Techn. Büro Österreich 83301 Traunreut, Germany www.heidenhain.de	IL	NEUMO VARGUS MARKETING LTD. Tel Aviv 61570, Israel E-mail: neumo@neumo-vargus.co.il	TH	HEIDENHAIN (THAILAND) LTD Bangkok 10250, Thailand www.heidenhain.co.th
AU	FCR Motion Technology Pty. Ltd Laverton North 3026, Australia E-mail: vicsales@fcrmotion.com	IN	HEIDENHAIN Optics & Electronics India Private Limited Chetpet, Chennai 600 031, India www.heidenhain.in	TR	T&M Mühendislik San. ve Tic. LTD. ŞTİ. 34728 Ömraniye-Istanbul, Turkey www.heidenhain.com.tr
BE	HEIDENHAIN NV/SA 1760 Roosdaal, Belgium www.heidenhain.be	IT	HEIDENHAIN ITALIANA S.r.l. 20128 Milano, Italy www.heidenhain.it	TW	HEIDENHAIN Co., Ltd. Taichung 40768, Taiwan R.O.C. www.heidenhain.com.tw
BG	ESD Bulgaria Ltd. Sofia 1172, Bulgaria www.esd.bg	JP	HEIDENHAIN K.K. Tokyo 102-0083, Japan www.heidenhain.co.jp	UA	Gertner Service GmbH Büro Kiev 01133 Kiev, Ukraine www.heidenhain.ua
BR	DIADUR Indústria e Comércio Ltda. 04763-070 São Paulo SP, Brazil www.heidenhain.com.br	KR	HEIDENHAIN Korea LTD. Gasan-Dong, Seoul, Korea 153-782 www.heidenhain.co.kr	US	HEIDENHAIN CORPORATION Schaumburg, IL 60173-5337, USA www.heidenhain.com
BY	GERTNER Service GmbH 220026 Minsk, Belarus www.heidenhain.by	MX	HEIDENHAIN CORPORATION MEXICO 20235 Aguascalientes, Ags., Mexico E-mail: info@heidenhain.com	VE	Maquinaria Diekmann S.A. Caracas, 1040-A, Venezuela E-mail: purchase@diekmann.com.ve
CA	HEIDENHAIN CORPORATION Mississauga, Ontario L5T2N2, Canada www.heidenhain.com	MY	ISOSERVE SDN. BHD. 43200 Balakong, Selangor E-mail: isoserve@pojaring.my	VN	AMS Co. Ltd HCM City, Vietnam E-mail: davidgoh@amsvn.com
CH	HEIDENHAIN (SCHWEIZ) AG 8603 Schwerzenbach, Switzerland www.heidenhain.ch	NL	HEIDENHAIN NEDERLAND B.V. 6716 BM Ede, Netherlands www.heidenhain.nl	ZA	MAFEMA SALES SERVICES C.C. Midrand 1685, South Africa www.heidenhain.co.za
CN	DR. JOHANNES HEIDENHAIN (CHINA) Co., Ltd. Beijing 101312, China www.heidenhain.com.cn	NO	HEIDENHAIN Scandinavia AB 7300 Orkanger, Norway www.heidenhain.no		
CZ	HEIDENHAIN s.r.o. 102 00 Praha 10, Czech Republic www.heidenhain.cz	PH	Machinebanks Corporation Quezon City, Philippines 1113 E-mail: info@machinebanks.com		
DK	TPTEKNIK A/S 2670 Greve, Denmark www.tp-gruppen.dk				

Zum Abheften hier falzen! / Fold here for lining!

* I _ 2 0 8 8 9 3 - 2 M *