

Mechanical Dimensions

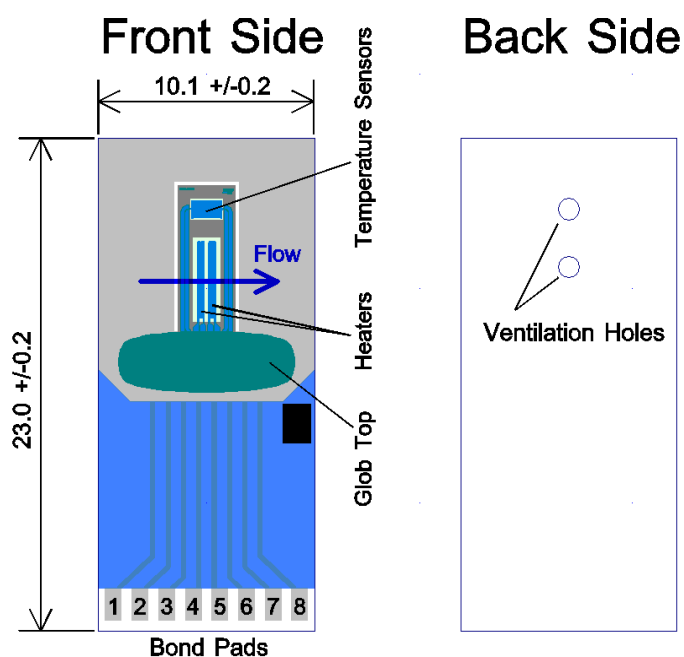

Mechanical dimensions and connections of LMM-H03

The sensor membrane has a thickness of about ~2 µm. Therefore it should not be exposed to any mechanical stress. One has to take care of a filter unit around the measurement device. High speed particles coming direct to the surface of the membrane can result in damages or shortage of the life time. The ventilation holes shall be kept open to release air pressure built up due to heating.

Parameter	Symbol	Condition	Min	Typ	Max	Unit
Length	L	+25 °C	22.8	23.0	23.2	mm
Width	W	+25 °C	9.95	10.15	10.35	mm
Height Ceramics	$H_{ceramics}$	+25 °C	0.48	0.63	0.78	mm
Height Ceramics + Metall	H_{Flow}	+25 °C	0.9	1.1	1.2	mm
Height max. Overall	H_{Total}	+25 °C	–	–	1.8	mm
Bond Pad Width	W_{Pad}	+25 °C	–	0.5	–	mm
Bond Pad Length	L_{Pad}	+25 °C	–	1.5	–	mm

Specification further

Parameter	Specification
Package Type	Hybride Ceramics
Pad Material	AgPt bondable with 150 µm Al-wire, also solderable

Application Example

One application of the LMM-H03 is to measure the amount of air coming into an engine. The actual mass air flow sensor module consists of a flow channel and a measurement channel, the so called Venturi channel. The measurement channel with the LMM-H03 should be placed in the center of the flow channel because at this place the flow is almost laminar and the flow velocity reaches its maximum. The cross sections of both channels can be adjusted to the amount of air which is supposed to be measured. For reproducible measurement results it is strictly required to avoid any turbulence at the surface of the sensing element.

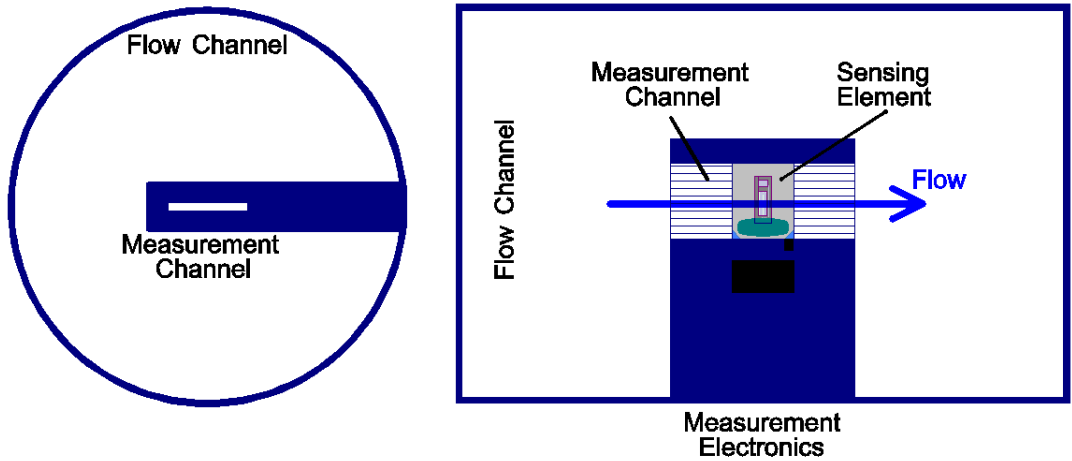

Flow channel of application example of a mass air flow sensor

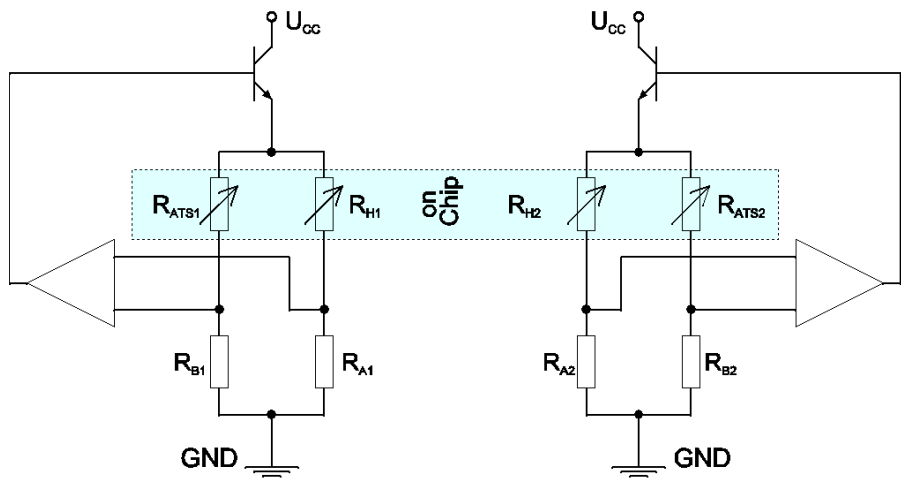

Above is shown an example of a measurement electronics using a Wheatstone-bridge. The resistors R_{Ax} and R_{Bx} need to be trimmed to operate the heater at a defined over-temperature
NOTE: This drawing shows only the basic functionality. This is not a ready to use circuit diagram!