

# Tachogeneratoren

## Vollwelle mit EURO-Flansch B10

### Mit eigener Lagerung

#### TDP 0,2, TDPZ 0,2



TDP 0,2

#### Technische Daten - elektrisch

Reversiertoleranz	≤0,1 %
Linearitätstoleranz	≤0,15 %
Temperaturkoeffizient	±0,05 %/K (Leerlauf)
Isolationsklasse	B
Kalibriertoleranz	±1 %
Klimatische Prüfung	Feuchte Wärme, konstant (IEC 60068-2-3, Ca)
Störfestigkeit	EN 61000-6-2
Störaussendung	EN 61000-6-3

#### TDP 0,2

Leistung	12 W (Drehzahl ≥3000 U/min)
Ankerkreis-Zeitkonstante	<75 µs
Leerlaufspannung	10...150 mV pro U/min

#### TDPZ 0,2

Leistung	2x 3 W (Drehzahl ≥3000 U/min)
Ankerkreis-Zeitkonstante	<40 µs
Leerlaufspannung	20...100 mV pro U/min

#### Merkmale

- Kurze Reaktionszeit
- Leerlaufspannung 10...150 mV pro U/min
- Redundanter Ausgang (TDPZ)
- EURO-Flansch B10 / Vollwelle ø11 mm
- Sehr hohe Schockfestigkeit
- Hohe Signalgüte über den gesamten Drehzahlbereich dank patentierter Longlife Technik
- Drehrichtungserkennung über Steuerung möglich

#### Optional

- Seeluft-/Tropenschutz
- Zweites Wellenende (B14) / Gehäusefuß (B3)
- Vollwelle ø7 und ø14 mm

#### Technische Daten - mechanisch

Baugröße (Flansch)	ø115 mm
Wellenart	ø11 mm Vollwelle ø7 mm Vollwelle (optional) ø14 mm Vollwelle (optional)
Flansch	EURO-Flansch B10
Schutzart DIN EN 60529	IP 55, IP 56 (optional)
Betriebsdrehzahl	≤10000 U/min
Drehmoment	1,5 Ncm
Zulässige Wellenbelastung	≤60 N axial ≤80 N radial
Werkstoffe	Gehäuse: Aluminium-Druckguss Welle: Edelstahl
Betriebstemperatur	-30...+130 °C
Widerstandsfähigkeit	DIN EN 60068-2-6 Vibration 10 g, 10-2000 Hz IEC 60068-2-27 Schock 300 g, 1 ms
Anschluss	Klemmenkasten

#### TDP 0,2

Trägheitsmoment Rotor	1,1 kgcm <sup>2</sup>
Masse ca.	2,4 kg

#### TDPZ 0,2

Trägheitsmoment Rotor	1,2 kgcm <sup>2</sup>
Masse ca.	2,9 kg

# Tachogeneratoren

## Vollwelle mit EURO-Flansch B10

### Mit eigener Lagerung

TDP 0,2, TDPZ 0,2

#### Bestellbezeichnung

##### Tachogenerator

TDP0,2LT-

	Leerlaufspannung
6	10 mV pro U/min
7	20 mV pro U/min
10	30 mV pro U/min
5	40 mV pro U/min
4	60 mV pro U/min
3	100 mV pro U/min
1	150 mV pro U/min

##### Doppel-Tachogenerator

TDPZ0,2LT-

	Leerlaufspannung
7	20 mV pro U/min
5	40 mV pro U/min
4	60 mV pro U/min
3	100 mV pro U/min

#### Daten nach Typ

Typ	Leerlaufspannung $U_0$ [mV/U/min]	Min. erforderlicher Lastwiderstand in Abhängigkeit vom Drehzahlbereich [U/min]			Max. Betriebsdrehzahl $n_{max}$ [U/min]	Anker-Widerstand $R_A(20^\circ C)$ [ $\Omega$ ]	Anker-Induktivität $L_A$ [mH]
		0-3000 $R_L$ [k $\Omega$ ]	0-6000 $R_L$ [k $\Omega$ ]	0- $n_{max}$ $R_L$ [k $\Omega$ ]			
TDP0,2LT-6	10	$\geq 0,1$	$\geq 0,3$	$\geq 0,9$	10000	3	6
TDP0,2LT-7	20	$\geq 0,3$	$\geq 1,2$	$\geq 3,3$	10000	11	23
TDP0,2LT-10	30	$\geq 0,7$	$\geq 2,7$	$\geq 7,5$	10000	26	50
TDP0,2LT-5	40	$\geq 1,2$	$\geq 5$	$\geq 13,5$	10000	47	90
TDP0,2LT-4	60	$\geq 2,7$	$\geq 11$	$\geq 30$	10000	99	200
TDP0,2LT-3	100	$\geq 7,5$	$\geq 30$	$\geq 30$	6000	271	550
TDP0,2LT-1	150	$\geq 16$	---	$\geq 30$	4000	630	1260

Doppel-Tachogenerator mit redundanten Ausgang  
(Die Daten gelten für jeden der beiden Tachogeneratorausgänge)

TDPZ0,2LT-7	20	$\geq 1,2$	$\geq 4,8$	$\geq 14$	10000	19	45
TDPZ0,2LT-5	40	$\geq 4,8$	$\geq 20$	$\geq 54$	10000	70	170
TDPZ0,2LT-4	60	$\geq 11$	$\geq 44$	$\geq 120$	10000	160	390
TDPZ0,2LT-3	100	$\geq 30$	$\geq 120$	---	6000	445	1080

Überlagerte Welligkeit (für  $\tau_{RC} = 0,7$  ms):  $\leq 0,5\%$  (Spitze-Spitze)  $\leq 0,2\%$  (effektiv)

#### Ersatzschaltbild

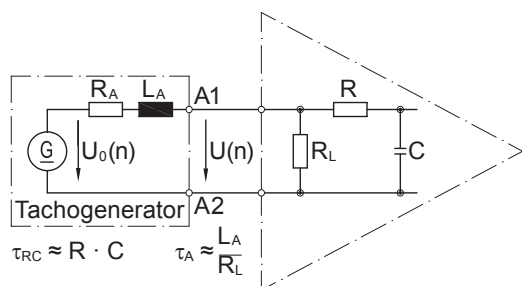

Polarität bei positiver Drehrichtung: A1 (TDPZ: 1A1, 2A1): + (VDE)  
A2 (TDPZ: 1A2, 2A2): - (VDE)

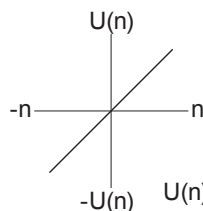

$$U(n) = U_0(n) \frac{R_L}{R_A + R_L} \approx U_0(n) \text{ für } R > R_L \gg R_A$$

# Tachogeneratoren

## Vollwelle mit EURO-Flansch B10

### Mit eigener Lagerung

TDP 0,2, TDPZ 0,2

#### Anschlussbelegung

**Ansicht A** - Anschlussklemmen TDP 0,2

Polarität bei positiver Drehrichtung

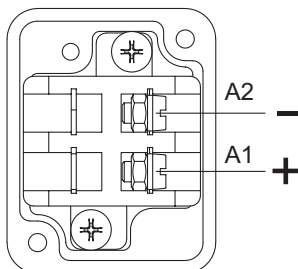

**Ansicht A** - Anschlussklemmen TDPZ 0,2

Polarität bei positiver Drehrichtung

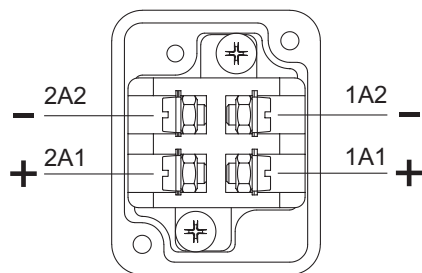

#### Zubehör

Kohlebürsten

#### Montagezubehör

K 35	Federscheiben-Kupplung für Vollwelle $\varnothing 6 \dots 12$ mm
K 50	Federscheiben-Kupplung für Vollwelle $\varnothing 11 \dots 16$ mm
K 60	Federscheiben-Kupplung für Vollwelle $\varnothing 11 \dots 22$ mm

# Tachogeneratoren

## Vollwelle mit EURO-Flansch B10

### Mit eigener Lagerung

TDP 0,2, TDPZ 0,2

#### Abmessungen

TDP 0,2 (TDPZ 0,2) - Version mit Euro-Flansch (B10)

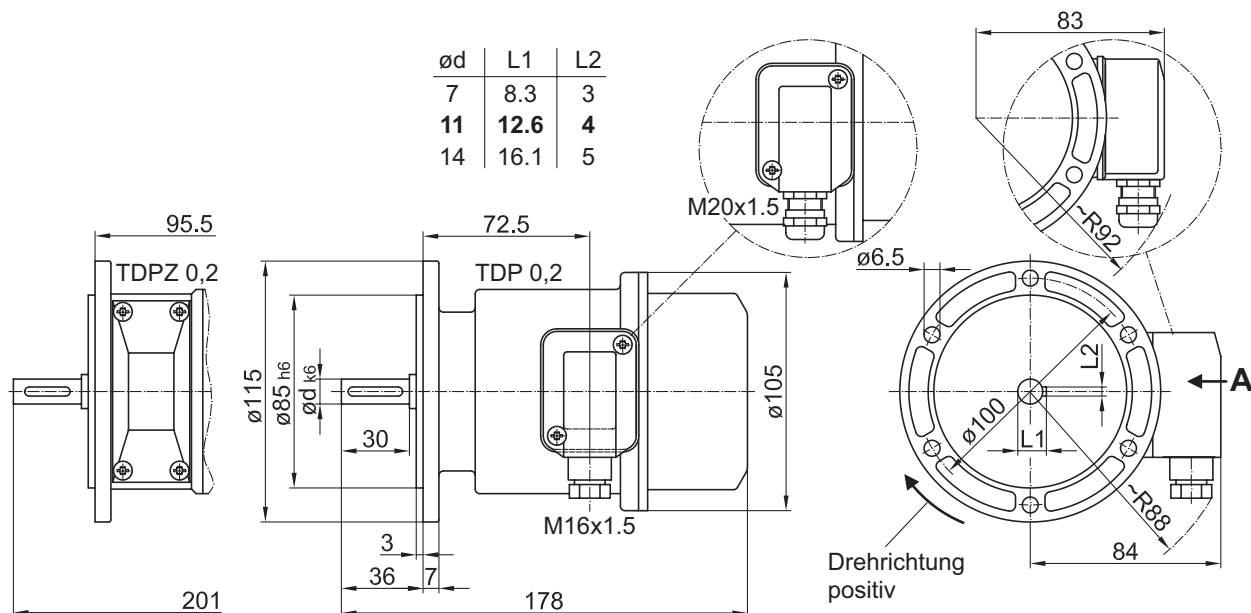

TDP 0,2 (TDPZ 0,2) - Version mit Gehäusefuss (B3)

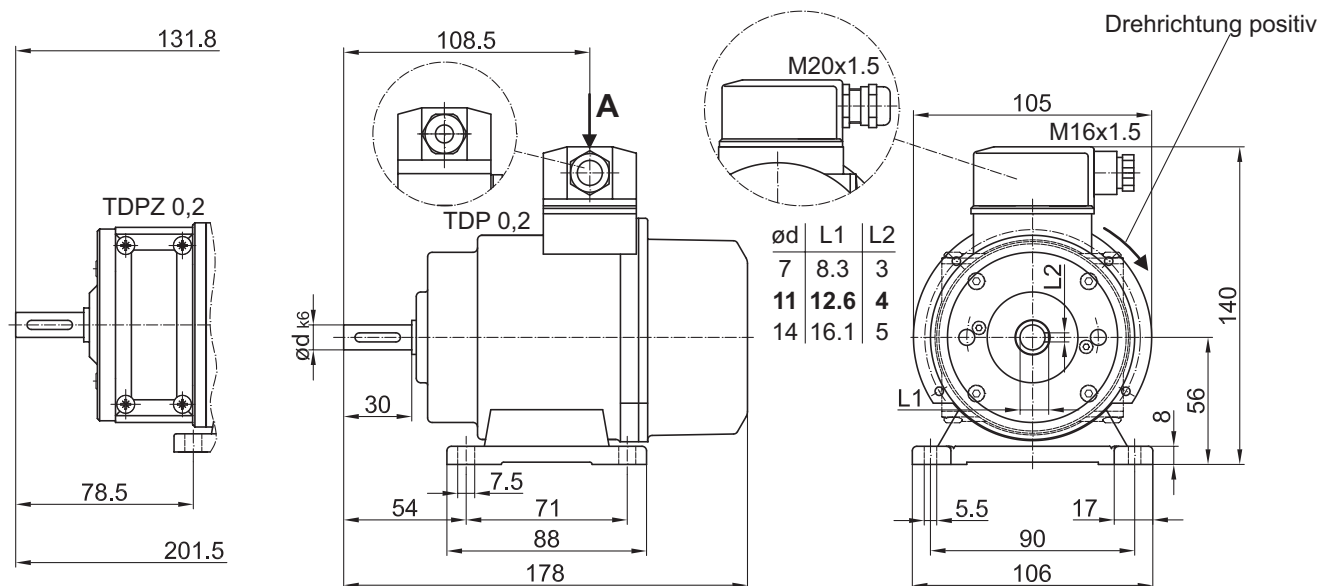

# Tachogenerators

## Solid shaft with EURO flange B10

### With own bearings

#### TDP 0,2, TDPZ 0,2



TDP 0,2

#### Technical data - electrical ratings

Reversal tolerance	≤0.1 %
Linearity tolerance	≤0.15 %
Temperature coefficient	±0.05 %/K (open-circuit)
Isolation class	B
Calibration tolerance	±1 %
Climatic test	Humid heat, constant (IEC 60068-2-3, Ca)
Interference immunity	EN 61000-6-2
Emitted interference	EN 61000-6-3

#### TDP 0,2

Performance	12 W (speed ≥3000 rpm)
Armature-circuit time-constant	<75 μs
Open-circuit voltage	10...150 mV per rpm

#### TDPZ 0,2

Performance	2x 3 W (speed ≥3000 rpm)
Armature-circuit time-constant	<40 μs
Open-circuit voltage	20...100 mV per rpm

#### Features

- Low response time
- Open circuit voltage 10...150 mV per rpm
- Redundant output (TDPZ)
- EURO-flange B10 / solid shaft ø11 mm
- Very high resistance to shock
- High signal quality due to patented LongLife technology
- Recognition of sense of rotation possible via control

#### Optional

- Marine air protected/tropicalized
- Second shaft end (B14) / Housing foot (B3)
- Solid shaft ø7 and ø14 mm

#### Technical data - mechanical design

Size (flange)	ø115 mm
Shaft type	ø11 mm solid shaft ø7 mm solid shaft (optional) ø14 mm solid shaft (optional)
Flange	EURO flange B10
Protection DIN EN 60529	IP 55, IP 56 (option)
Operating speed	≤10000 rpm
Torque	1.5 Ncm
Shaft loading	≤60 N axial ≤80 N radial
Materials	Housing: aluminium die-cast Shaft: stainless steel
Operating temperature	-30...+130 °C
Resistance	DIN EN 60068-2-6 Vibration 10 g, 10-2000 Hz IEC 60068-2-27 Shock 300 g, 1 ms
Connection	Terminal box

#### TDP 0,2

Rotor moment of inertia	1.1 kgcm <sup>2</sup>
Weight approx.	2.4 kg

#### TDPZ 0,2

Rotor moment of inertia	1.2 kgcm <sup>2</sup>
Weight approx.	2.9 kg

# Tachogenerators

## Solid shaft with EURO flange B10

### With own bearings

TDP 0,2, TDPZ 0,2

#### Part number

#### Tachogenerator

TDP0,2LT-

Open-circuit voltage

6	10 mV per rpm
7	20 mV per rpm
10	30 mV per rpm
5	40 mV per rpm
4	60 mV per rpm
3	100 mV per rpm
1	150 mV per rpm

#### Twin tachogenerator

TDPZ0,2LT-

Open-circuit voltage

7	20 mV per rpm
5	40 mV per rpm
4	60 mV per rpm
3	100 mV per rpm

#### Data according to type

Type	Open-circuit voltage $U_0$ [mV/rpm]	Minimum load required depending on speed range [rpm]			Maximum operating speed $n_{max}$ [rpm]	Armature resistance $R_A(20^\circ C)$ [ $\Omega$ ]	Armature inductance $L_A$ [mH]
		0-3000 $R_L$ [k $\Omega$ ]	0-6000 $R_L$ [k $\Omega$ ]	0- $n_{max}$ $R_L$ [k $\Omega$ ]			
TDP0,2LT-6	10	$\geq 0.1$	$\geq 0.3$	$\geq 0.9$	10000	3	6
TDP0,2LT-7	20	$\geq 0.3$	$\geq 1.2$	$\geq 3.3$	10000	11	23
TDP0,2LT-10	30	$\geq 0.7$	$\geq 2.7$	$\geq 7.5$	10000	26	50
TDP0,2LT-5	40	$\geq 1.2$	$\geq 5$	$\geq 13.5$	10000	47	90
TDP0,2LT-4	60	$\geq 2.7$	$\geq 11$	$\geq 30$	10000	99	200
TDP0,2LT-3	100	$\geq 7.5$	$\geq 30$	$\geq 30$	6000	271	550
TDP0,2LT-1	150	$\geq 16$	---	$\geq 30$	4000	630	1260

Twin tachogenerator with redundant output  
(The data refer to each of the two tachogenerator outputs)

TDPZ0,2LT-7	20	$\geq 1.2$	$\geq 4.8$	$\geq 14$	10000	19	45
TDPZ0,2LT-5	40	$\geq 4.8$	$\geq 20$	$\geq 54$	10000	70	170
TDPZ0,2LT-4	60	$\geq 11$	$\geq 44$	$\geq 120$	10000	160	390
TDPZ0,2LT-3	100	$\geq 30$	$\geq 120$	---	6000	445	1080

Superimposed ripple (for  $\tau_{RC} = 0.7$  ms):  $\leq 0.5\%$  (peak-peak)  $\leq 0.2\%$  (rms)

#### Replacement switching diagram

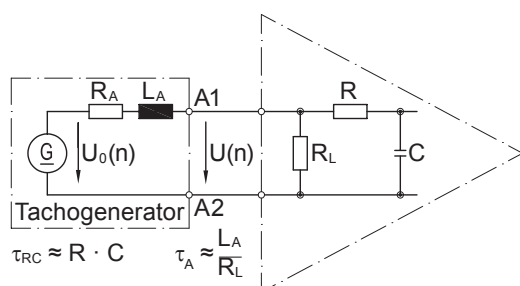

Polarity for positive rotating direction: A1 (TDPZ: 1A1, 2A1): + (VDE)  
A2 (TDPZ: 1A2, 2A2): - (VDE)

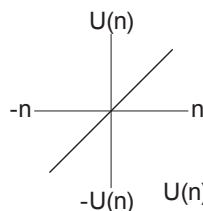

$$U(n) = U_0(n) \frac{R_L}{R_A + R_L} \approx U_0(n) \text{ for } R > R_L \gg R_A$$

# Tachogenerators

## Solid shaft with EURO flange B10

### With own bearings

#### TDP 0,2, TDPZ 0,2

##### Terminal assignment

**View A** - Connecting terminal TDP 0,2

Polarity for positive direction of rotation

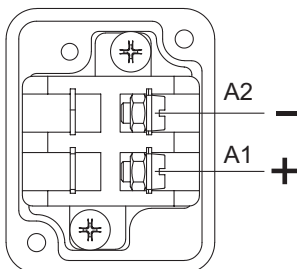

**View A** - Connecting terminal TDPZ 0,2

Polarity for positive direction of rotation

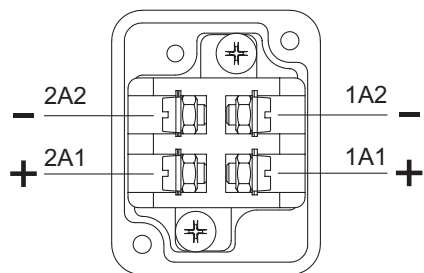

##### Accessories

Carbon brushes

##### Mounting accessories

K 35	Spring disk coupling for solid shaft $\varnothing 6...12$ mm
K 50	Spring disk coupling for solid shaft $\varnothing 11...16$ mm
K 60	Spring disk coupling for solid shaft $\varnothing 11...22$ mm

# Tachogenerators

## Solid shaft with EURO flange B10

### With own bearings

TDP 0,2, TDPZ 0,2

#### Dimensions

TDP 0,2 (TDPZ 0,2) - Version with Euro flange (B10)

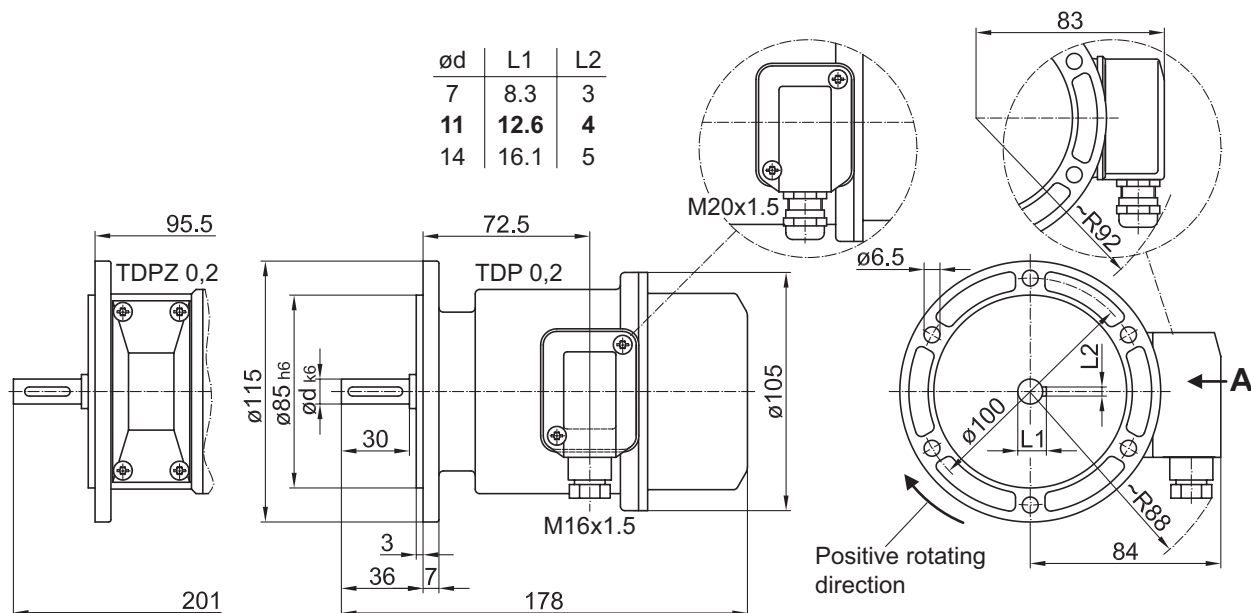

TDP 0,2 (TDPZ 0,2) - Version with housing foot (B3)

