

# RAC 2

## Main Spindle Drive Controller

Project Planning Manual

DOK-DIAX01-RAC02\*\*\*\*\*-PRJ1-EN-P





---

About this Documentation

---

Table of Contents

---

Construction of the RAC 2 Main Spindle Drive Controller 1

---

Planning the Control Cabinet 2

---

AS Programming Module 3

---

Condition Upon Delivery 4

---

Identification of Hardware 5

---

Storage and Transport 6

---

Mounting 7

---

Installation Guidelines 8

---

Commissioning Guidelines 9

---

Servicing Guidelines 10

---

Index 11

---

Overview of Supplementary Documentation 12

---



**Titel** RAC 2  
Main Spindle Drive Controller

**Type of documentation:** Project Planning Manual

**Documenttype** DOK-DIAX01-RAC02\*\*\*\*\*-PRJ1-EN-E1,44

**Internal file reference** • 209-0042-4115-00

**Reference** This electronic document is based on the hardcopy document with document desig.: 209-0042-4115 EN/02.94

**This documentation is used:** This documentation serves —

- to introduce the drive controller,
- to integrate the drive controller into the mechanical design of the control cabinet,
- to assist in mounting and installation,
- to describe programming module AS,
- to explain the hardware delivered and storage conditions.

**Function of the supplementary documentation** The supplementary documentation is used:

- when commissioning, operating and servicing,
- to integrate the drive controller into the electrical design of the control cabinet.

„Documentation Summary“ lists all technical documentation for the main spindle drives and their contents.

The „Supplementary Documentation“ contains all titles with their order numbers.

**Change procedures**

Designation of documentation up to present edition	Release-date	Comments
209-0042-4115-01 EN/02.94	Feb/94	First Edition
DOK-DIAX01-RAC02*****-PRJ1-EN-E1,44	Jul./97	First E-Dok

**Copyright** © INDRAMAT GmbH, 1994

Copying of this document, and giving it to others and the use or communication of the contents thereof, are forbidden without express authority. Offenders are liable to the payment of damages.

All rights are reserved in the event of the grant of a patent or the registration of a utility model or design. (DIN 34-1)

The electronic documentation (E-doc) may be copied as often as needed if such are to be used by the consumer for the purpose intended.

**Validity** All rights reserved with respect to the content of this documentation and the availability of the products.

**Publisher** INDRAMAT GmbH • Bgm.-Dr.-Nebel-Straße 2 • D-97816 Lohr  
Telefon 0 93 52 / 40-0 • Tx 689421 • Fax 0 93 52 / 40-48 85

Dept ENA (MR, KK, FS)

## Summary of documentation „AC - Main Spindle Drives with ...

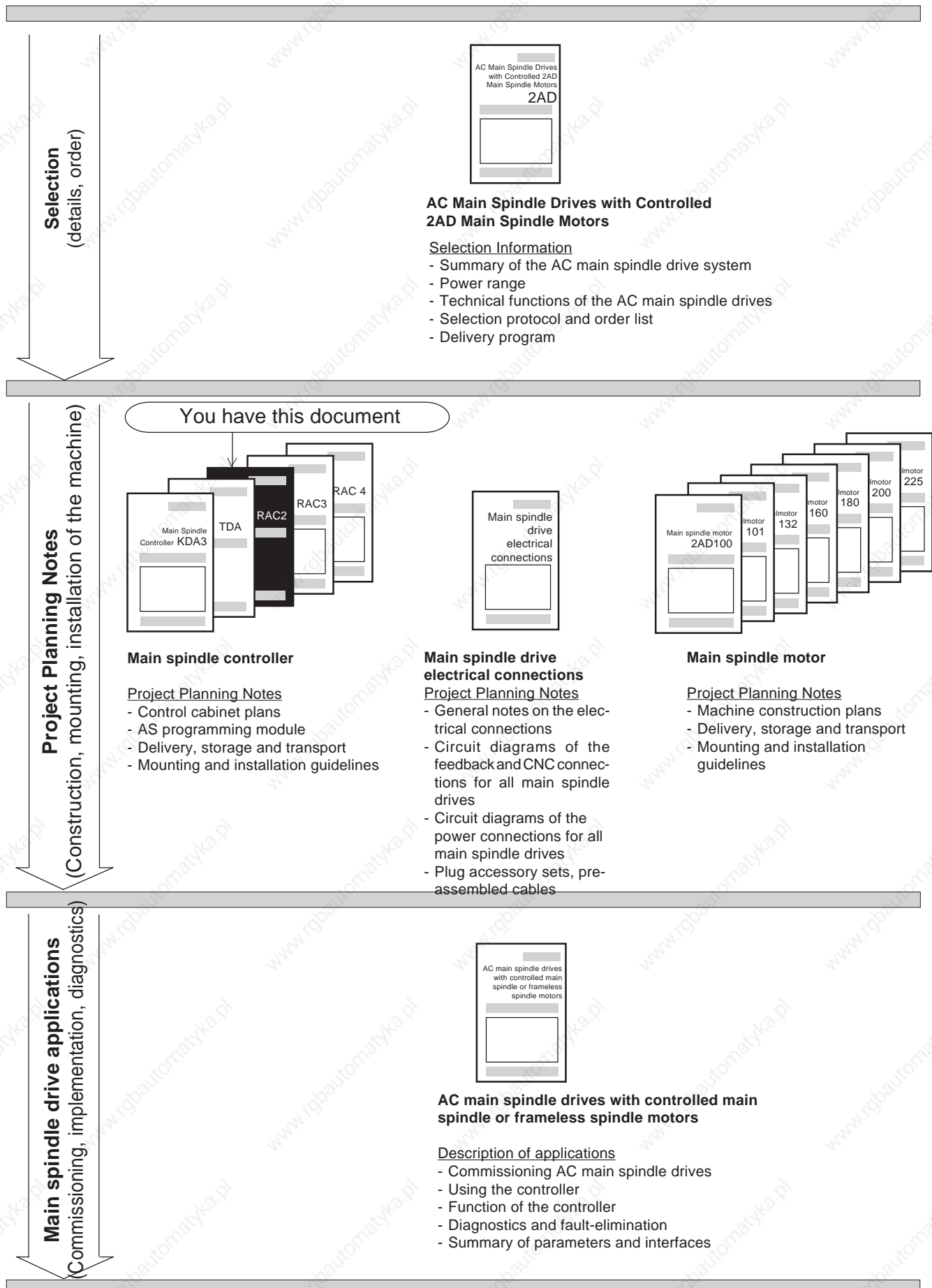
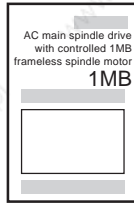

Figure: Summary of Documentation

## ... controlled main spindle motor or frameless spindle motor“



### AC main spindle drive with controlled 1MB frameless spindle motor

Selection data

- Summary of the AC main spindle drive system
- Power ratings
- Application functions of the AC main spindle drive
- Selection protocol and order list
- Available versions

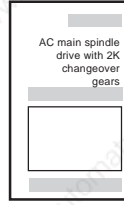

### AC main spindle drive with 2AD controlled main spindle motor and 2K changeover planetary gears

Selection data

- Summary of the AC main spindle drive system
- Power ratings
- Order guidelines

**Selection**  
(details, order)

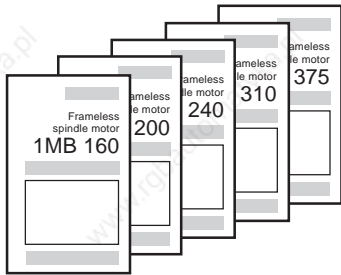

### Frameless spindle motor

Project Planning Notes

- Machine construction plans
- Integration into the cooling system
- Electrical and coolant connections
- Delivery

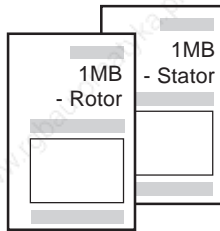

Mounting Guidelines

- Delivery, handling, transport
- Mounting
- Cooling specifications

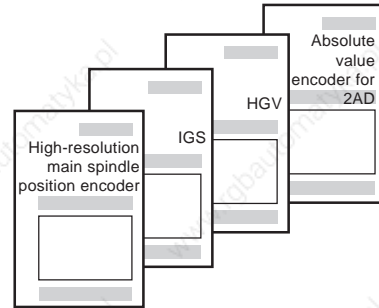

### Supplementary documentation

- High-resolution main spindle position encoder
- IGS incremental encoder output
- HGV high-resolution main spindle position encoder junctions
- Absolute value encoder attachment for 2AD 132, 2AD 160, 2AD 180

**Project Planning Notes**  
(Construction, mounting, installation of the machine)

**Main spindle drive applications**  
(Commissioning, implementation, diagnostics)



<b>Table of Contents</b>	<b>Page</b>
<b>1. Construction of the RAC 2 Main Spindle Drive Controller</b>	<b>11</b>
<b>2. Planning the Control Cabinet</b>	<b>17</b>
2.1. Operating Conditions .....	17
2.2. Mechanical Data .....	20
2.3. Thermal Data .....	26
2.3.1. Guidelines on the Use of Cooling Devices in Control Cabinets .....	28
2.4. Electrical Data .....	30
2.5. Summary of Technical Data .....	37
2.6. Type Codes .....	38
<b>3. AS Programming Module</b>	<b>39</b>
3.1. AS Programming Module Types .....	40
3.2. AS Programming Module Compatibility .....	40
3.3. Type Plate Data .....	41
3.4. Type Code .....	41
<b>4. Condition Upon Delivery</b>	<b>42</b>
<b>5. Identification of Hardware</b>	<b>43</b>
<b>6. Storage and Transport</b>	<b>46</b>
<b>7. Mounting</b>	<b>47</b>
7.1. Mounting in the Control Cabinet .....	48
<b>8. Installation Guidelines</b>	<b>50</b>
<b>9. Commissioning Guidelines</b>	<b>51</b>
<b>10. Servicing Guidelines</b>	<b>52</b>
10.1. Fault Diagnoses .....	52
10.2. Equipment Defect .....	52
10.3. Service Representatives .....	55
<b>11. Index</b>	<b>57</b>
<b>12. Overview of Supplementary Documentation</b>	<b>60</b>



## 1. Presenting the RAC 2 Main Spindle Drive Controller



Figure 1.1: RAC 2 Main Spindle Drive Controller

The RAC 2 main spindle drive controller provides intelligent digital control of INDRAMAT 2AD asynchronous main spindle motors and 1MB frameless spindle motors with a continuous motor output of 30 to 52 kw at the drive shaft of the motor.

### Main Spindle Drive

Drives implementing the RAC 2 drive controller are characterized by high stiffness and a broad speed range with continuous power. This makes them particularly well-suited for use as main spindle drives in numerically controlled machine tools.

### Spindle Positioning

In addition to the broad speed range, the AC main spindle drive with RAC 2 has an internal position control loop. It independently positions the spindle in response to a signal, e.g., for the purpose of exchanging a work piece. Maximum resolution is 1/4 000 000 revolutions. The drive controller internal position control loop is closed either by motor feedback (with direct drive or 1:1 gears) or by additional, optional spindle feedback (change speed or belt gears).

### C-Axis Operation

The AC main spindle drive with RAC 2 is also capable of operating the spindle as a servo-axis (C-axis) with extreme precision in the position control loop. The main spindle drive is equipped with high-resolution feedback to handle the low speeds which this requires. The controller acknowledges rotor position with a maximum resolution of 1/4 000 000 revolutions. This means that even the lowest speeds can be precisely controlled.

## 1. Presenting the RAC 2 Main Spindle Drive Controller

### Controller for Direct Mains Connection

The RAC 2 can be directly connected to three-phase supply networks with either 3\* 400 volts, 50 Hz, +/- 15%, or 3\* 460 volts, 60 Hz, +/- 10%. Both the mains contactor and the emergency stop switch are integrated. The energy regenerated during braking is fed back into the three-phase supply network. This occurs even in an emergency stop. The RAC 2 is capable of stopping the main spindle via direct current braking in the event of a power failure.

### Cooling

The heatsink for both power electronics and fan are built into the RAC main spindle drive controller housing. The cooling air flow is guided through the unit in an air shaft.

RAC drive controllers can be cooled with control cabinet outside or inside air. Either is possible in every RAC. The necessary structural changes are simple to make and can be performed without accessories.

### Cooling with Air Inside the Control Cabinet

The cooling air is drawn in from inside the control cabinet and then blown out.

### Cooling with Air Outside the Control Cabinet

The cooling air is drawn in and blown out of the control cabinet through cut-outs in the control cabinet backwall. The heat from energy loss is fed into the control cabinet outside air.

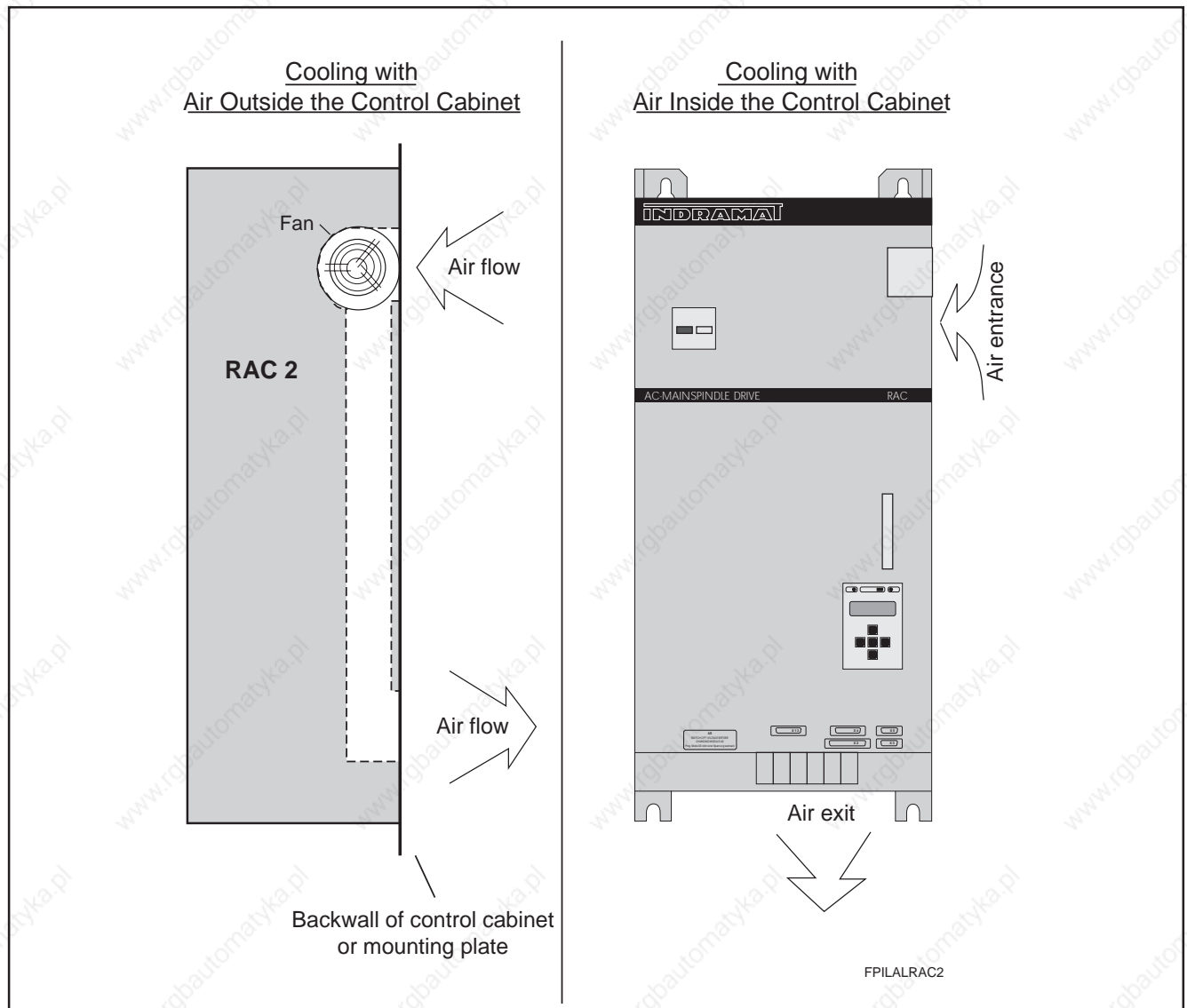

Figure 1.2: Possible cooling methods for the RAC 2

## 1. Presenting the RAC 2 Main Spindle Drive Controller

### Hose Cooling

If for structural reasons it should be not be possible to place cut-outs in the control cabinet backwall, then the RAC 2 controller can be equipped with hose cooling.

The cooling air is then drawn in over a hose outside of the control cabinet and blown out again.



**Mounting parts are needed for hose cooling. These parts are supplied as an accessory kit. The hose itself is not part of the kit, but can be ordered from INDRAMAT.**

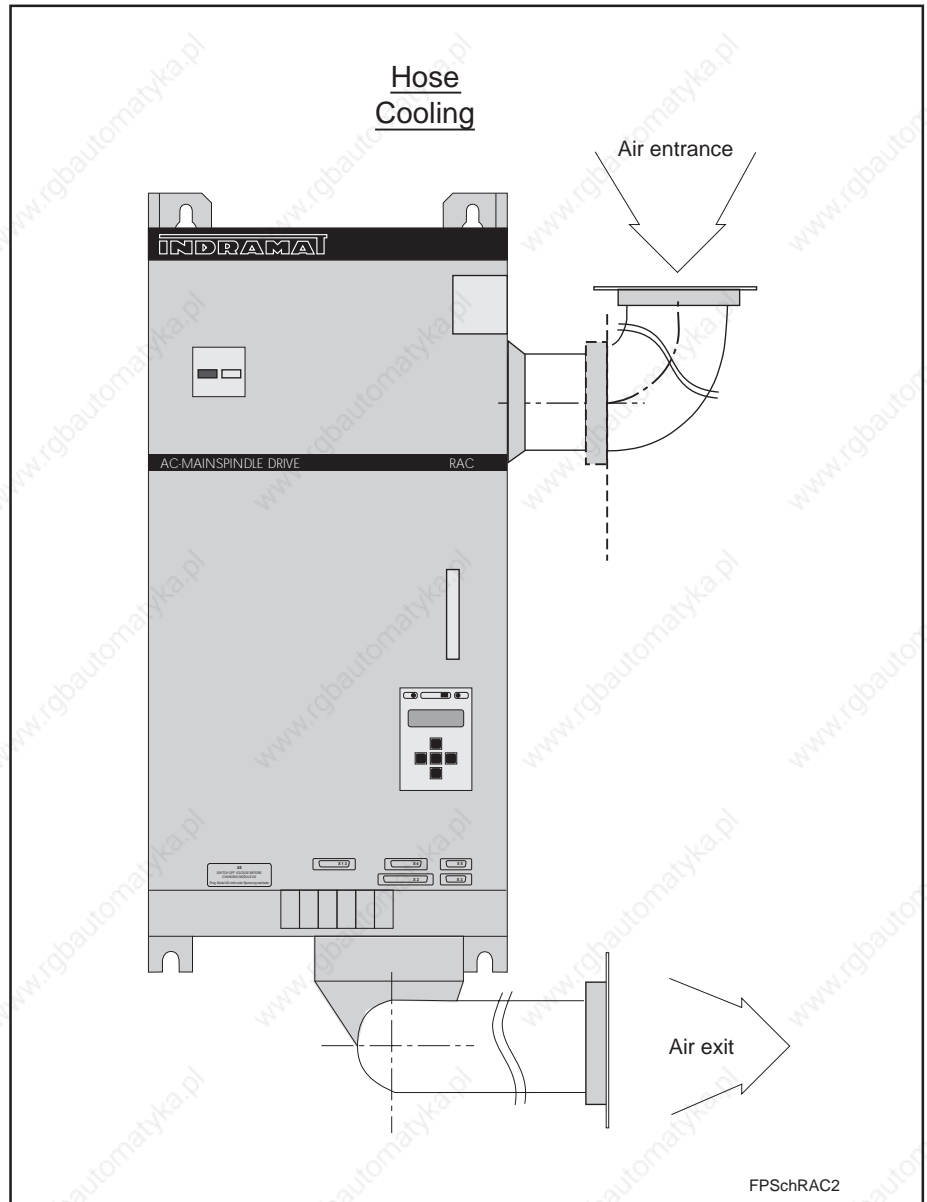

Figure 1.3: Hose cooling in the RAC 2

# 1. Presenting the RAC 2 Main Spindle Drive Controller

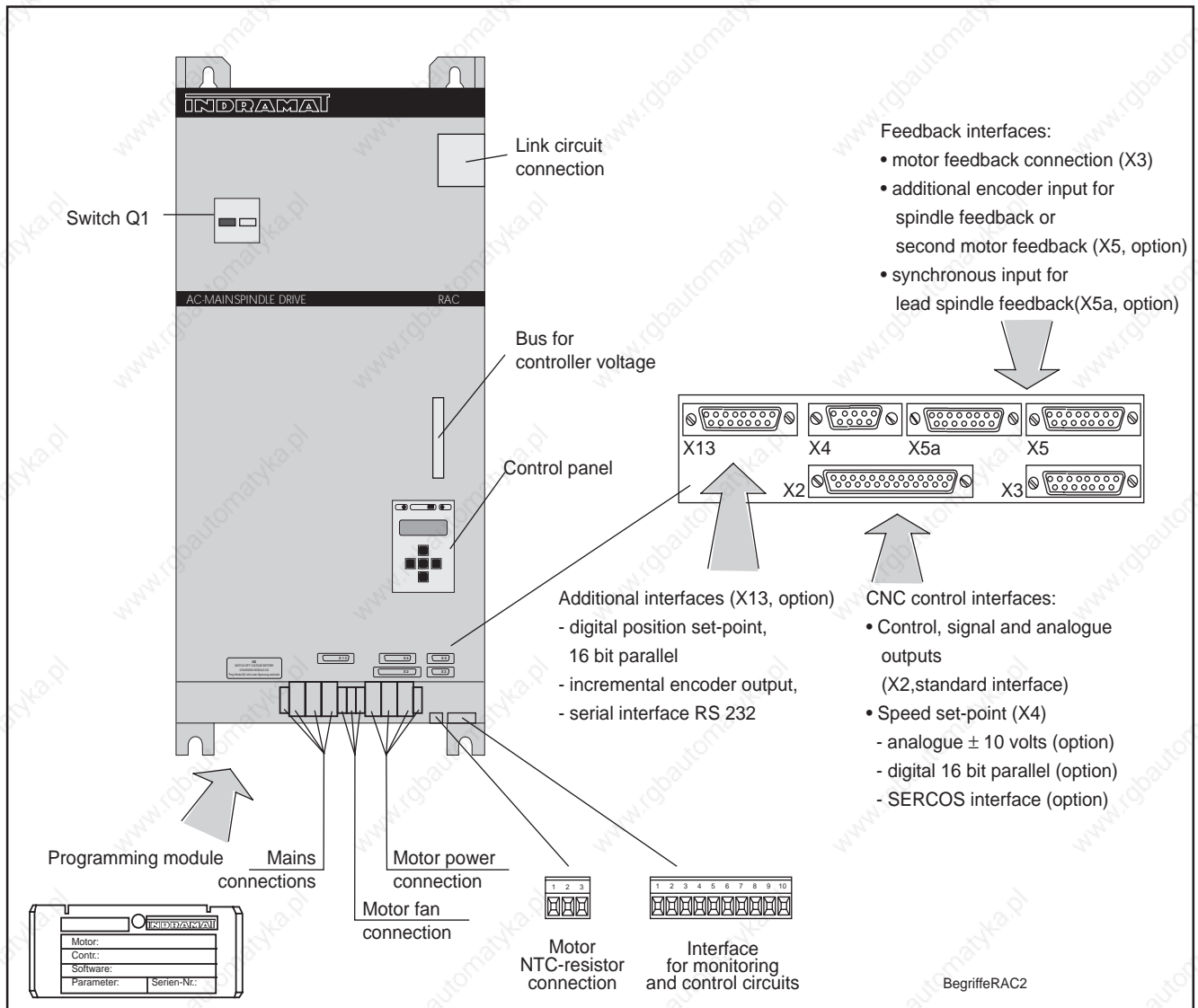

Figure 1.4: Allocation of terms on the RAC 2

With the presence of the link circuit connection and the control voltage bus, the RAC 2 is equipped to supply an additional modular main spindle controller.

## Programming Module

The individual parameters, needed for installation and application, are input on site during commissioning, using the keypad on the control panel. These parameter values are stored, together with the motor optimizing parameter values, on the plugged-in programming module.

Only the controller needs to be exchanged should servicing become necessary. The programming module is reused in the new controller. The drive features are stored on the programming module and are immediately available.

## Interface Options

### Speed Set-Point

The controllers are available with different interfaces for the speed set-point:

- Analogue speed set-point  
+/- 10 volts for connection to conventional CNC controls,
- Digital speed set-point  
16 bit parallel for connection to PLC controllers, advantageous with longer circuit lengths and low set-points,
- SERCOS interface  
The real-time communication of set-point and actual values of speed, position and torque, including parameter handling to the CNC controls.

### Additional encoder input, synchronous input

An additional encoder input is available for connecting spindle feedback to the internal position controller. Additional encoder input and synchronous input (connection of lead spindle feedback) are available for spindle synchronization.

### Additional Interface

The RAC 2 drive controller offers an optional additional interface which is available as

- an incremental encoder output  
for position control via the CNC control during C-axis operation or screwing, tapping,
- a serial interface  
for storing and loading parameters with a PC,
- an input for digital position set-points  
16-bit parallel, using the PLC controller to dial 3,600 positions

1. Presenting the RAC 2 Main Spindle Drive Controller

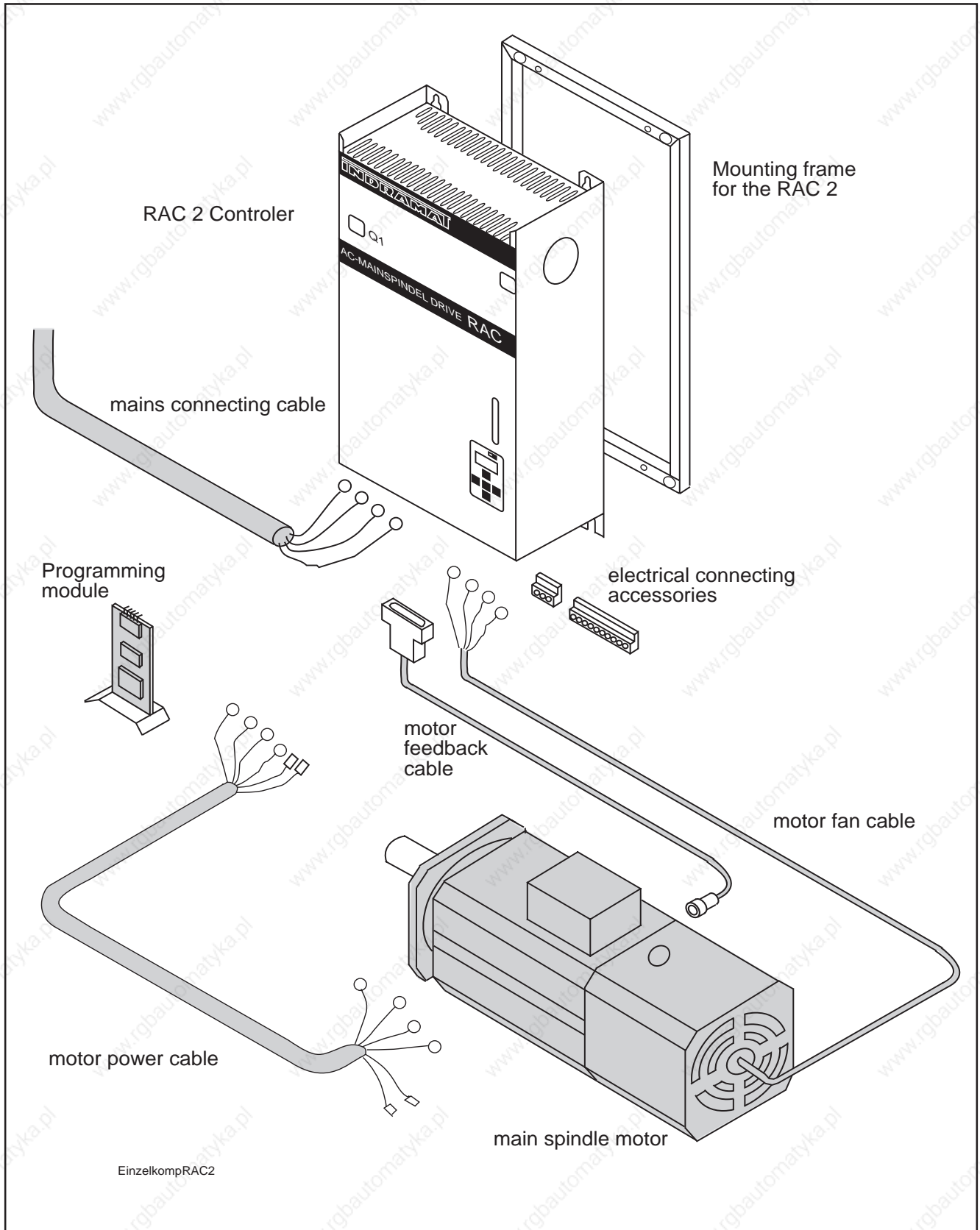

Figure 1.5: Individual components of a main spindle drive with allocation of terms.

## 2. Planning the Control Cabinet

The information to structurally integrate the RAC 2 main spindle drive controller is broken down into:

- operating conditions
- mechanical data
- thermal data
- electrical data
- technical data/type code

### 2.1. Operating Conditions

#### Ambient Temperature

The main spindle drive values listed apply without restriction if the controller is operated within an ambient temperature range of +5 to +45 degrees C. Maximum permissible ambient temperature equals +55 degrees C. There is a reduction in the given values as indicated in the diagram in Fig. 2.1.

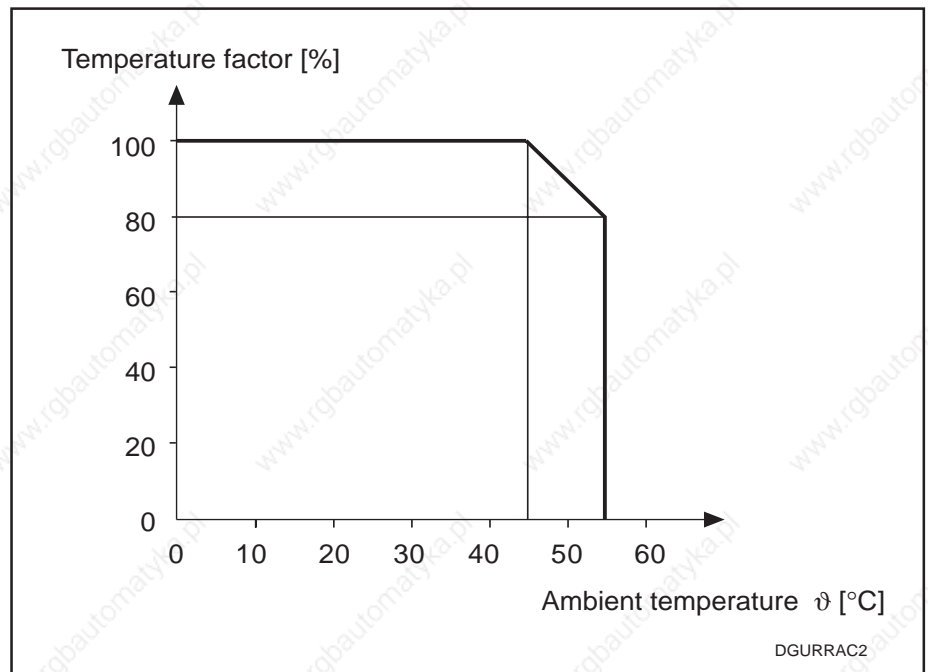

Figure 2.1: Ambient temperature-dependent reductions in drive data.

Installation Altitude

Maximum installation altitude equals 1000 meters above sea level. The values for rated torque and power, as listed for the main spindle drives, decrease with greater altitude. This decrease is depicted in the diagram in Figure 2.2.

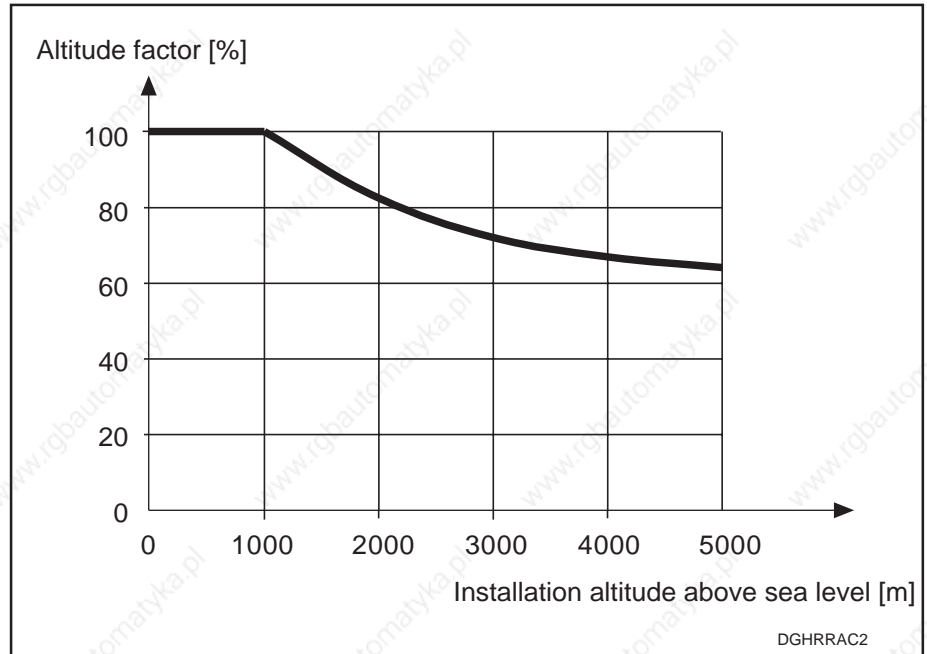

Figure 2.2: Altitude-dependent reduction in drive data

Permissible ambient humidity

Maximum ambient humidity corresponds to humidity class F, in acc. with DIN 40 040.

This means that it is possible to operate the controller in humidity-risk rooms such as workshops in cold/moderate and dry/warm climates. Average relative humidity must not exceed 70% in the most humid month of the year! Condensation water must not be permitted to form!

Protection Classification for the RAC Controller

The protection class is IP 10 in acc. with EN 60 529 (DIN VDE 0470).

This means that the controller is protected against penetration by solid objects with a diameter greater than 50 mm.

The controller is not protected against

- water and
- deliberate penetration, e.g., by a hand. It does keep larger body surfaces out.

The RAC 2 has been manufactured in accordance with DIN VDE 0160, Sec. 5.5.1.3 and 6.5.1.3 for mounting into a control cabinet or sealed housing. Sufficient protective measures to prevent contact must be implemented by engineering in a manner appropriate to the respective control cabinet design, and these must be in acc. with the safety guidelines for the specific application. (For industrial use, e.g., EN 60204 / DIN VDE 0113, Sect. 1).

### Control Cabinet Protection Type

The type of protection used for the control cabinet is not affected if the RAC control cabinet is cooled with inside air.

The type of protection is affected if the RAC is cooled with outside air because the air flow is drawn in over cut-outs and fed through the control cabinet.

IP 54 is the protection category for the inside of the control cabinet, if mounted according to guidelines (Chap. 7). IP 24 is the protection category for the fan (see Fig. 1.2.).

2.2. Mechanical Data

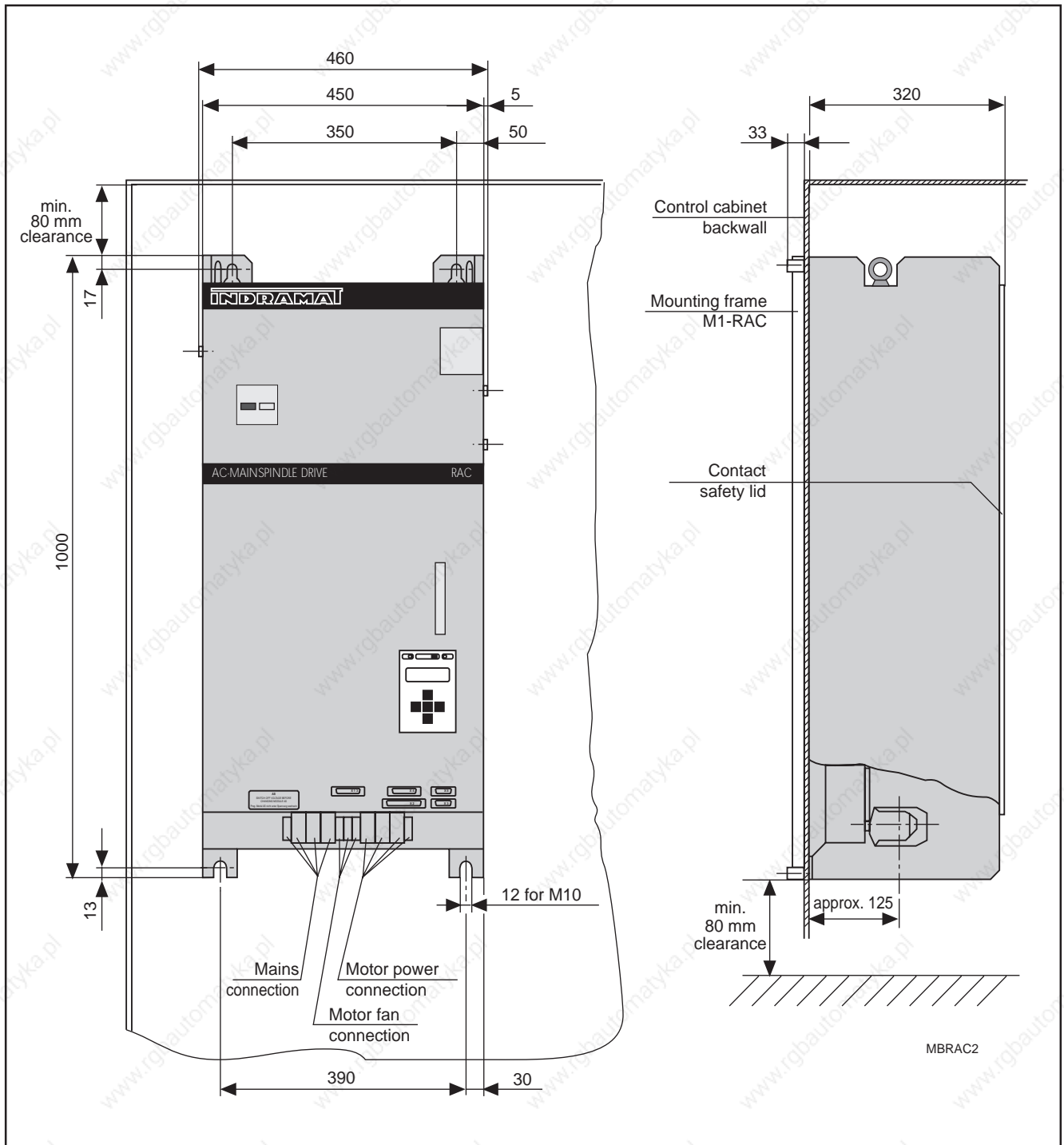

Figure 2.3: RAC 2 Main Spindle Drive Controller Dimensional Data

The controller may only be operated in the position depicted!

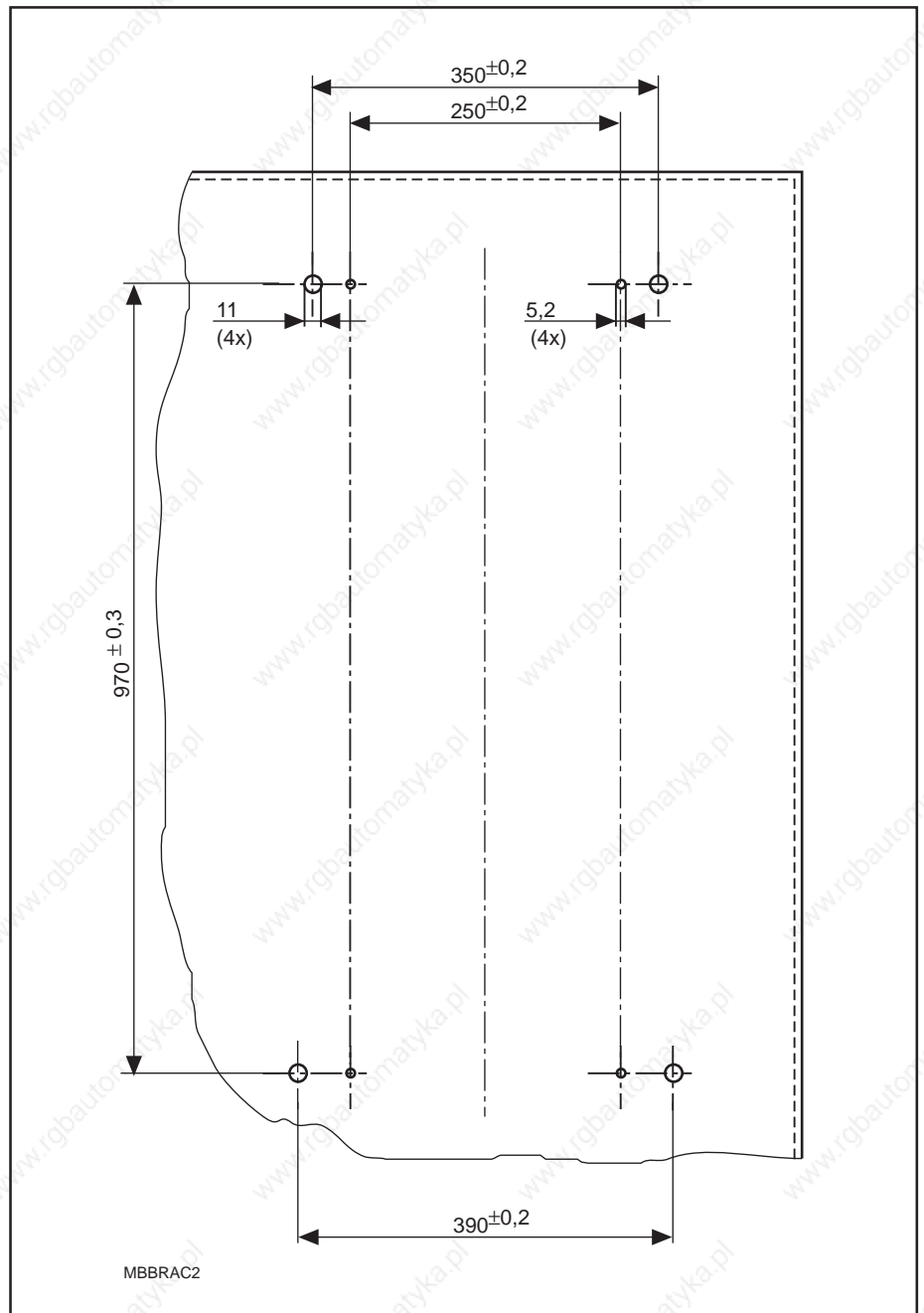

Figure 2.4: Drill diagram for backwall of control cabinet.

## 2. Planning the Control Cabinet

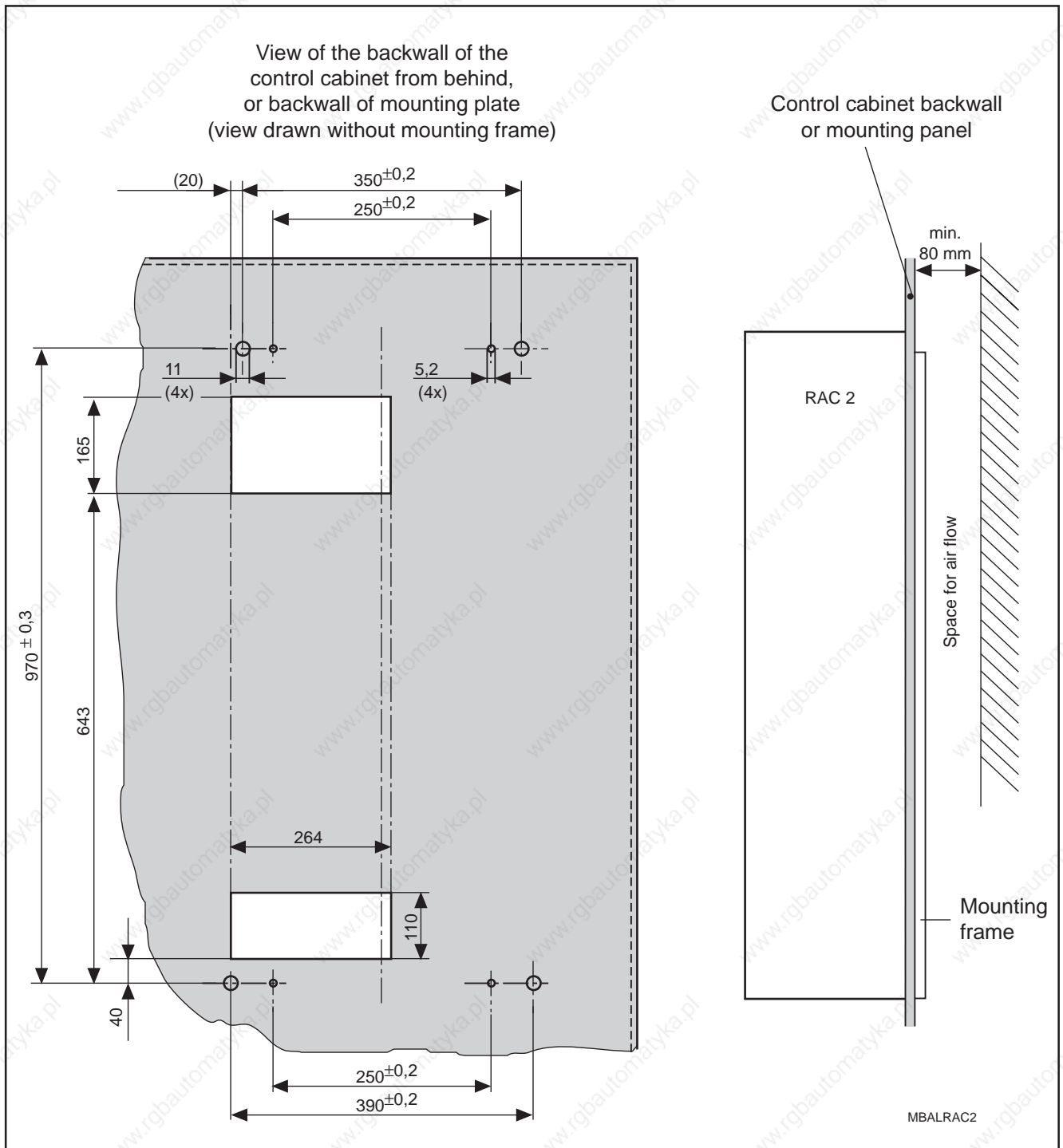

Figure 2.5: Additional dimensions for cooling control cabinet with outside air.

## 2. Planning the Control Cabinet

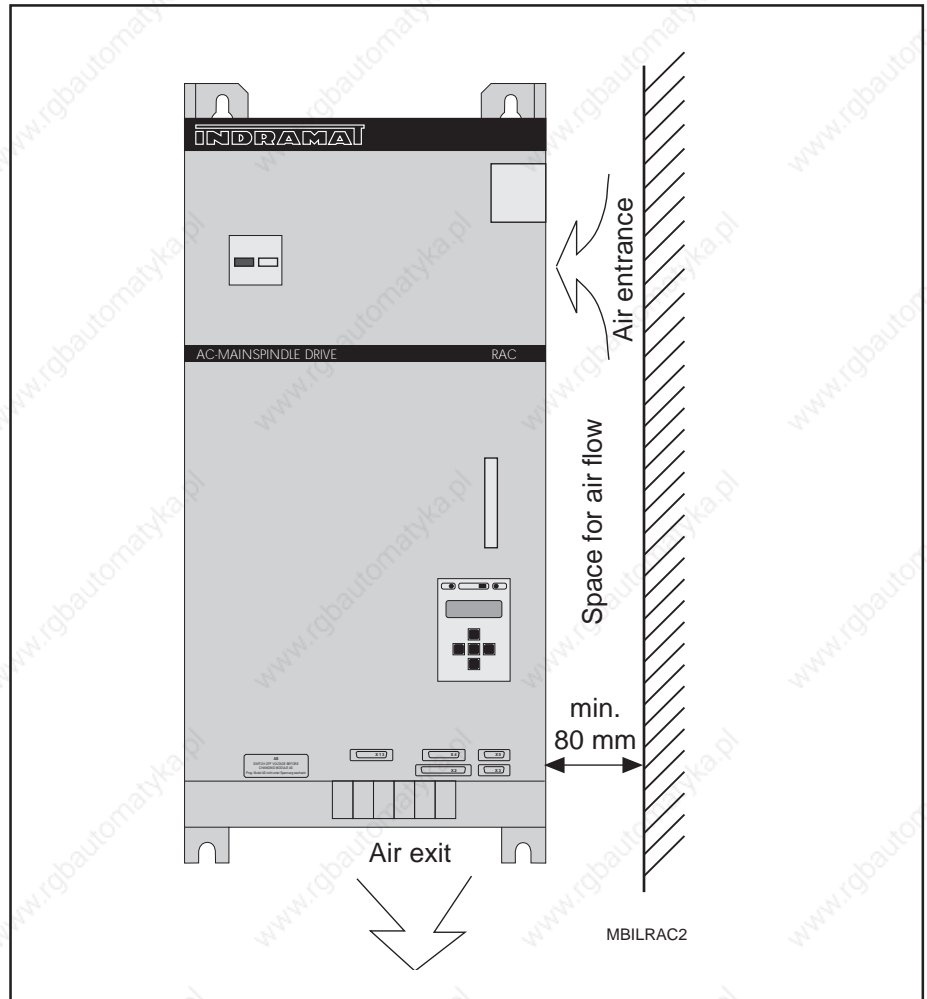

Fig. 2.6: Additional dimensions for cooling control cabinet with inside air.

## 2. Planning the Control Cabinet

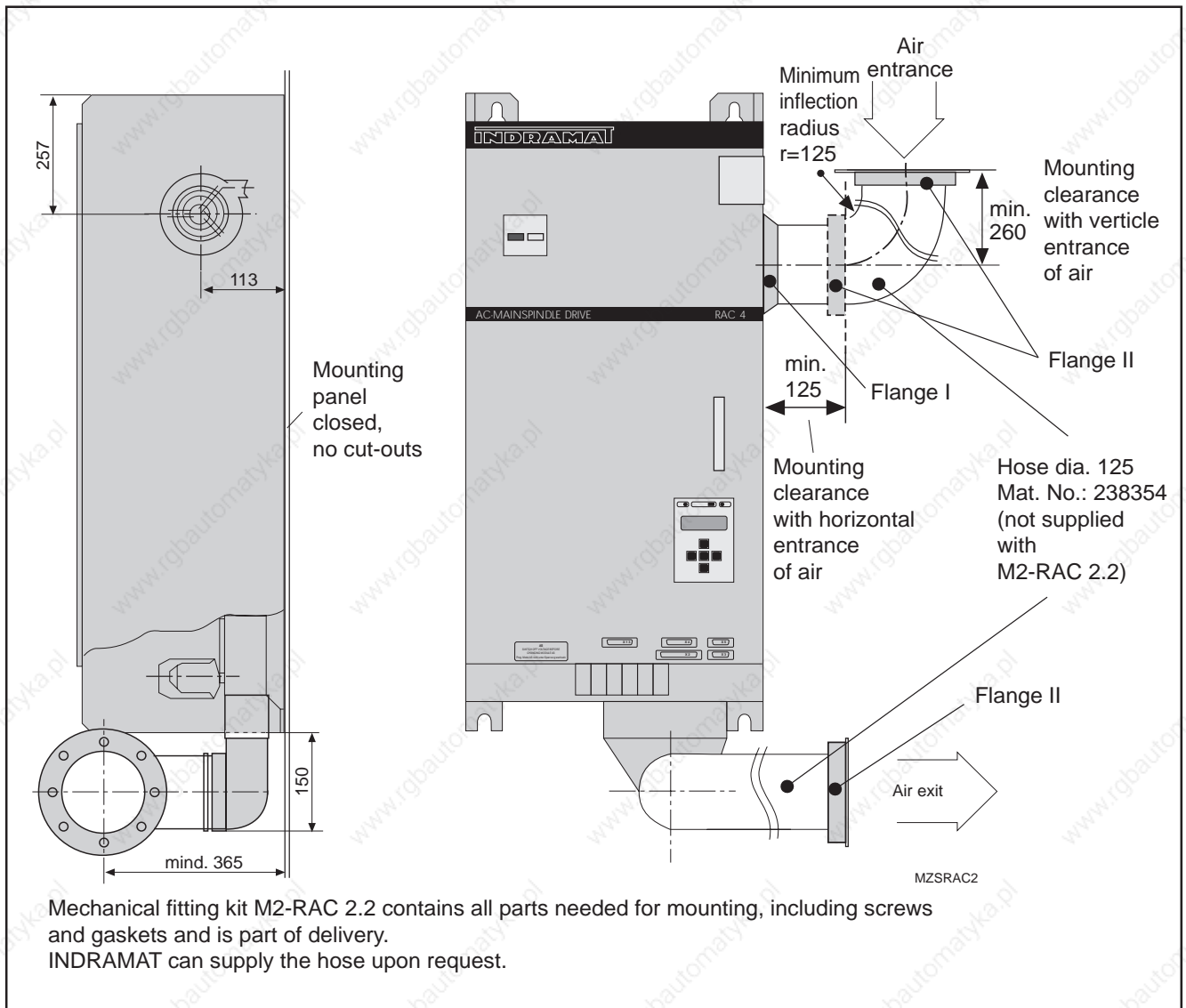

Figure 2.7: Additional dimensional data for hose cooling.

## 2. Planning the Control Cabinet

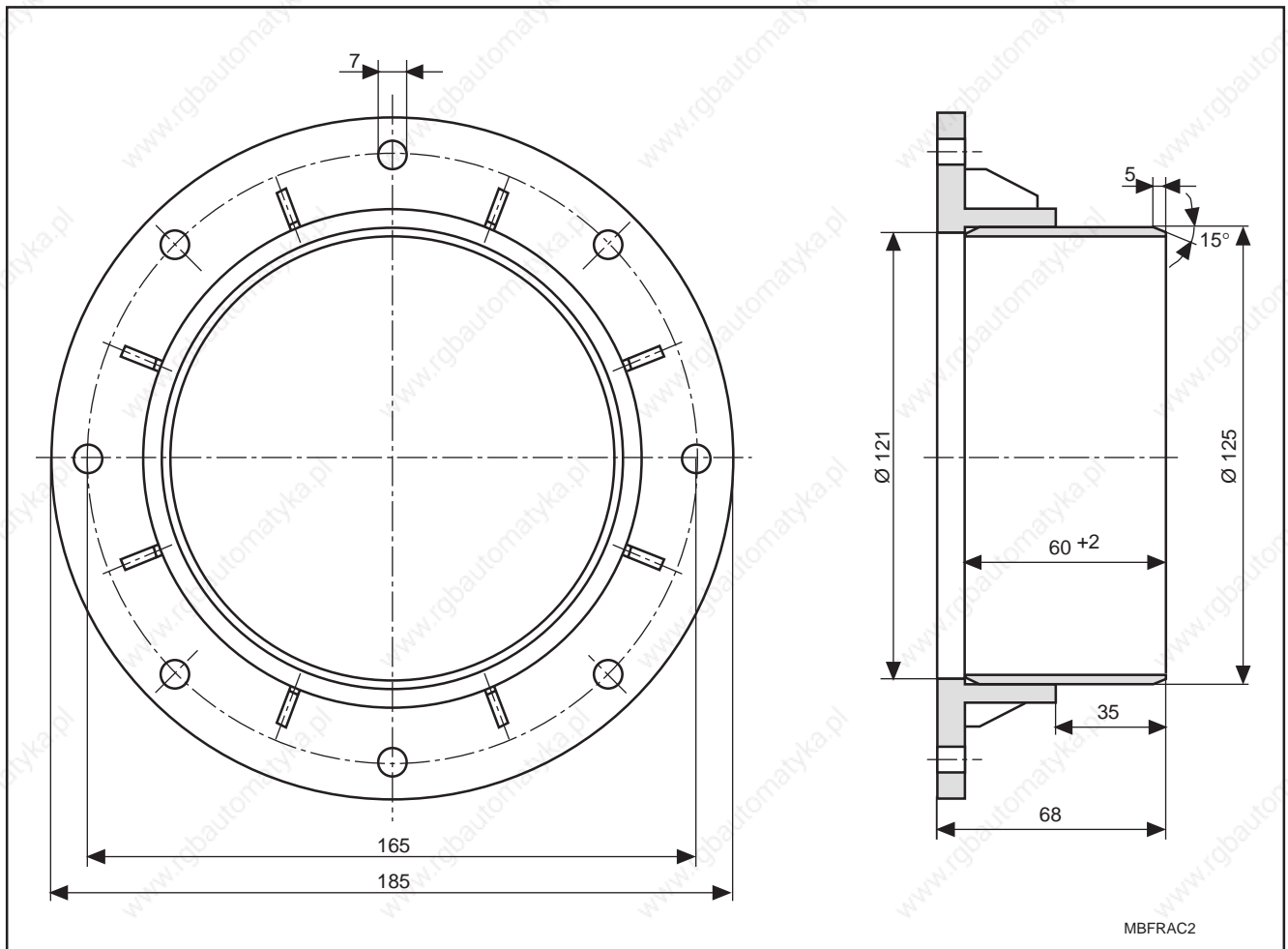

Figure 2.8: Flange II dimensions sheet for hose cooling.

2.3. Thermal Data

Power Dissipation

The RAC 2 drive controller emits heat during operation which is discharged over the air slits in the cover and the built-in heatsink.

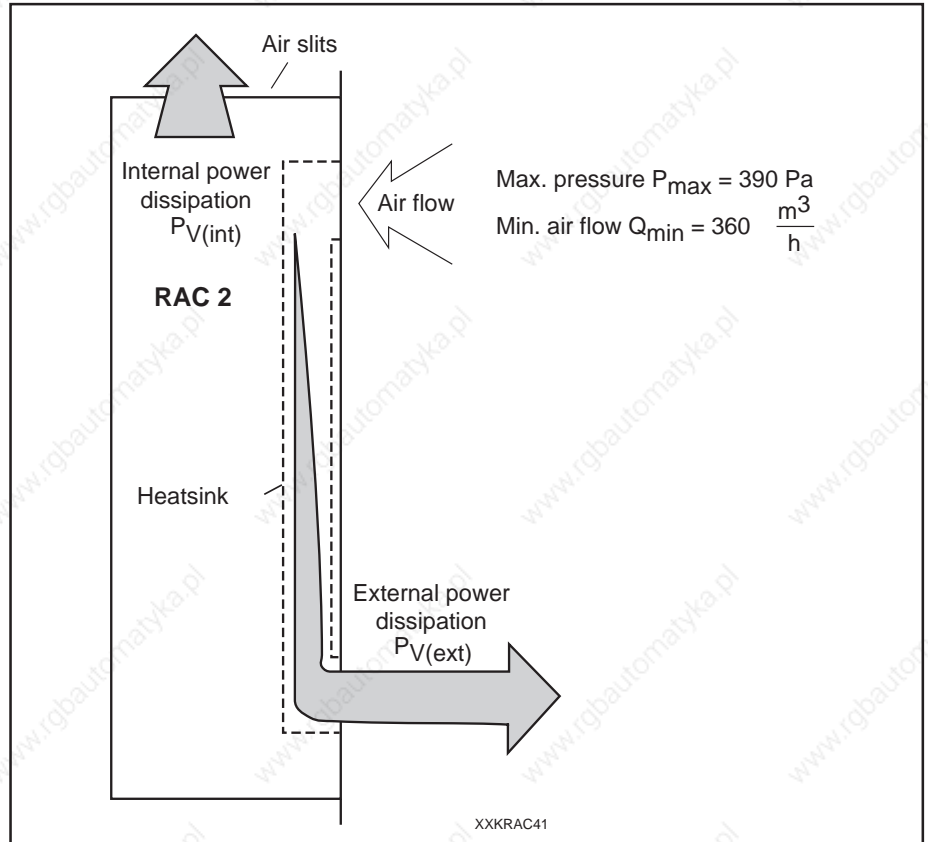

Figure 2.9: Cooling the RAC 2 drive controller

The internal and external power dissipated by the RAC 2 controller is workload-dependent. It suffices to know what the power dissipation dependent upon rated power of the main spindle motor is, when working out the dimensions for the control cabinet or cooling system.

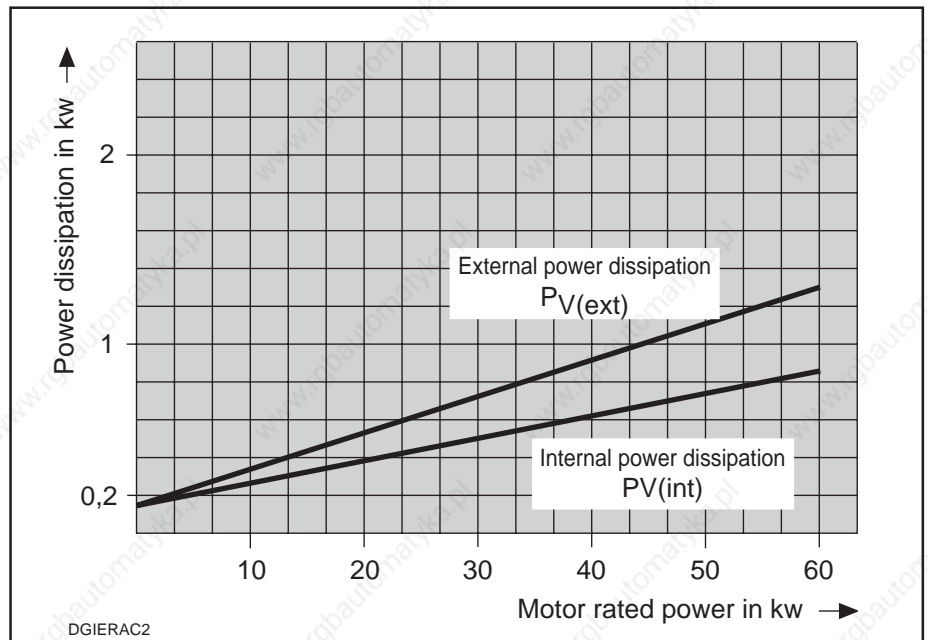

Figure 2.10: Breakdown of internal and external power dissipation

## 2. Planning the Control Cabinet

---

The controller can be cooled with either control cabinet inside or outside air. Depending upon the mounting method, the cooling air for the heatsink either remains in the control cabinet or is drawn in from outside and then blown back outside. (Heat exchange principle.)

The controller is supplied with the outside air cooling method. Structural changes are necessary if inside air or hose cooling are to be used (see Chap. 7).

If air is to be fed in and out over an air shaft, then some consideration must be given to the dimensions of the air shaft (required air flow)! If hose cooling is used, then the hoses must be kept as short as possible with no more than two 90 degree inflections.

The air flow value,  $Q$ , and maximum permissible overpressure,  $P_{max}$ , should be monitored as a safety measure.



**Both air shafts and heatsinks must be kept clean, otherwise there is danger of overheating!**

### 2.3.1. Guidelines on the Use of Cooling Devices in Control Cabinets

The RAC 2 controller can only be operated with an ambient temperature of up to 45 degrees C. without reduction in drive data. In order to be able to maintain this, it may be necessary to use a cooling device cool the inside air of the control cabinet.

Danger from Humidity

Humidity and condensation water endanger the installed controller if the cooling devices used are not properly installed!

Danger from Condensation Water

Humid air enters the control cabinet and creates condensation on the controller as it cools down!

Proper Use of Cooling Devices

If the cooling unit is improperly arranged in the control cabinet, then it is possible that the condensation water constantly being created in the cooling unit can either drip on or be sprayed onto the controller with the air flow.

Avoiding Condensation

- Only well-sealed control cabinets should be used with cooling devices. This helps avoid condensation caused by hot, humid outside air which could otherwise enter the cabinet!
- If control cabinets are operated with the door open (during commissioning, servicing, etc.), it must be warranted when closing the door, that the controllers are not cooler than the outside air, as otherwise dew could form. This means it is necessary to run the cooling unit, even if the facility is shut down, until the temperature of the control cabinet air and that of the installed units has reached the same level.
- Set the cooling device at a constant 40 degrees C, no lower!
- Cooling devices with follow-up temperature should be set so that the temperature of the air inside the control cabinet is less than 2 degrees C. lower than the temperature of the air outside the control cabinet. Set temperature limit at 40 degrees C.!
- The cooling units must always be arranged so that any condensation water formed cannot drip onto the installed controllers. Cooling units mounted on the top of the controllers necessitate a special control cabinet design (see Fig. 2.11)!
- The control cabinet should be constructed in such a way that the cooling unit fan cannot spray the condensation water, which has collected after shutdowns, onto the controller (see Fig. 2.12)!

Avoiding Dripping or Spraying Water

## 2. Planning the Control Cabinet

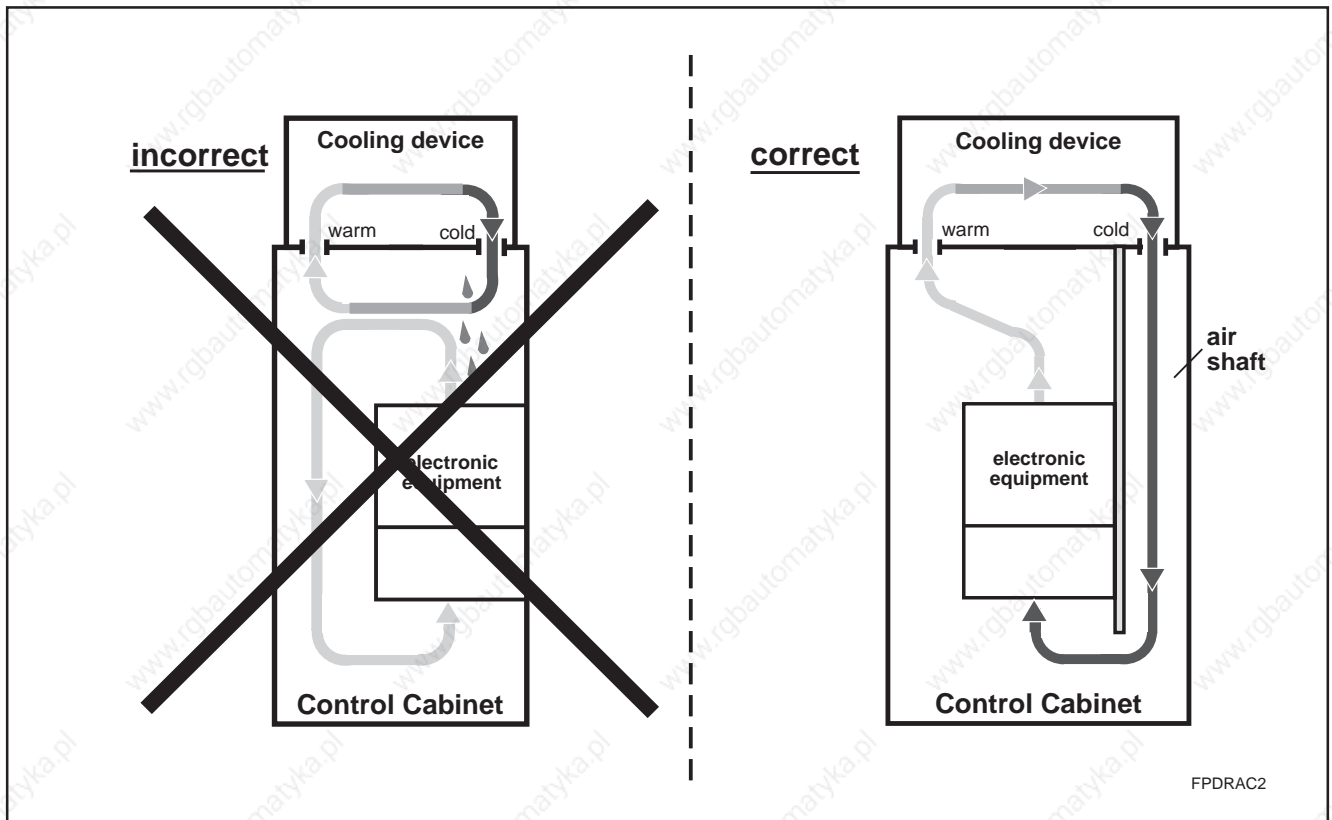

Fig. 2.11: Cooling device mounted on top of control cabinet

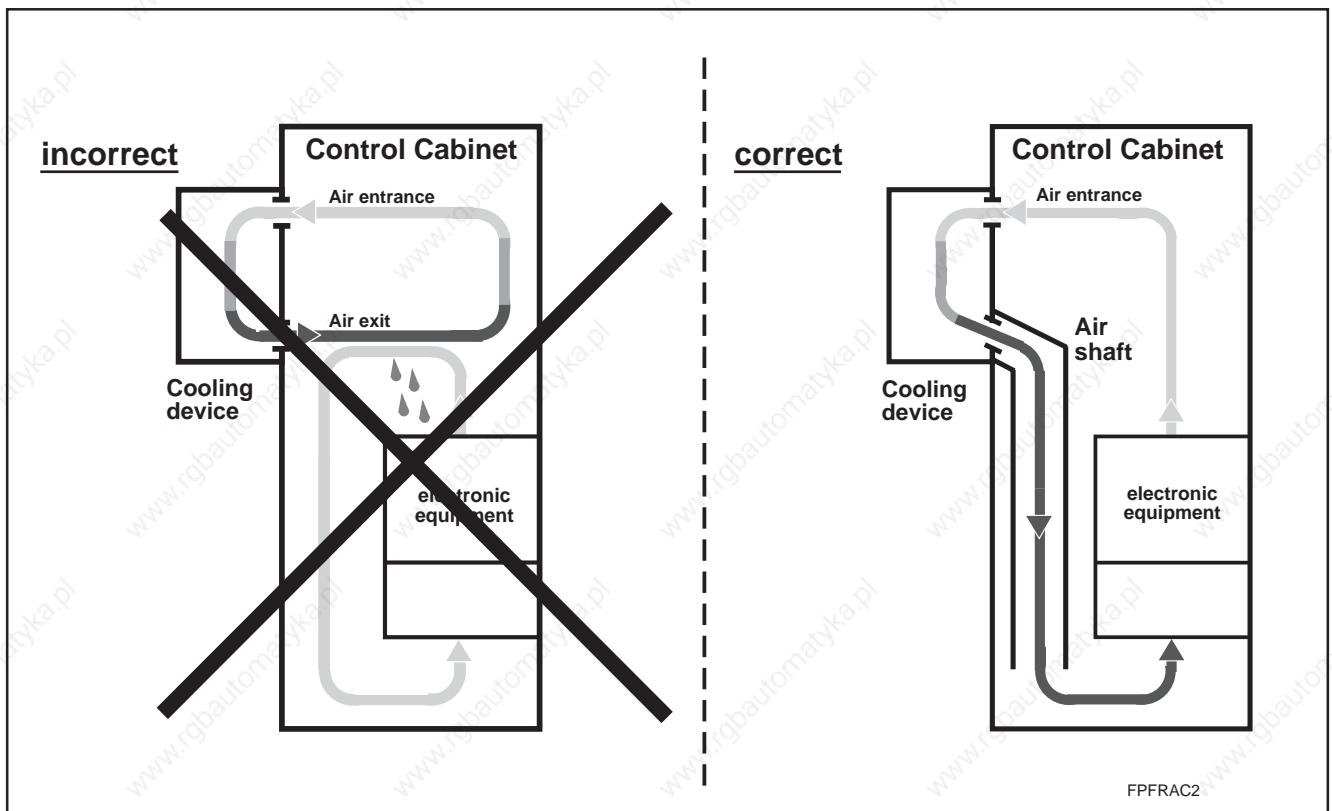

Figure 2.12: Cooling device arranged on front of control cabinet



**The cooling device must not be permitted to drip condensation water onto the installed controller!  
Cooling device temperature must be properly set!**

## 2.4. Electrical Data

### Connection Plan (schematic)

The connection plan depicted in Fig. 2.13 is schematic in nature. It is a checklist for all electrical connections required for operating a main spindle drive.

The electrical connections of INDRAMAT's main spindle drives are standardized to keep the variety of cables limited.

There are three categories of electrical connections for all of INDRAMAT's main spindle drives:

- feedback and CNC connections
- power connections
- controller-specific connections

### Connection diagrams for feedback, CNC and power connections

Independent of the main spindle controller, the feedback and CNC connections and the power connections (mains supply, motor power supply) have identical plug and terminal assignments. The circuit diagrams are summarized in the document: „Electrical Connections of the Main Spindle Drive; Planning and Design“ (doc. no. 209-0042-4111). This documentation is a must when generating the facility circuit diagrams!

### Installing the controller-specific interfaces

In addition to the already noted electrical connections, mains contactor controls and monitors, as well as a „ready state“ evaluation contact are needed to integrate the RAC 2 controller into the control cabinet circuits. These connections are specific to all RAC controllers. They are connected via terminal strip X15 (see Fig. 2.17) The aforementioned documentation contains a connection diagram.

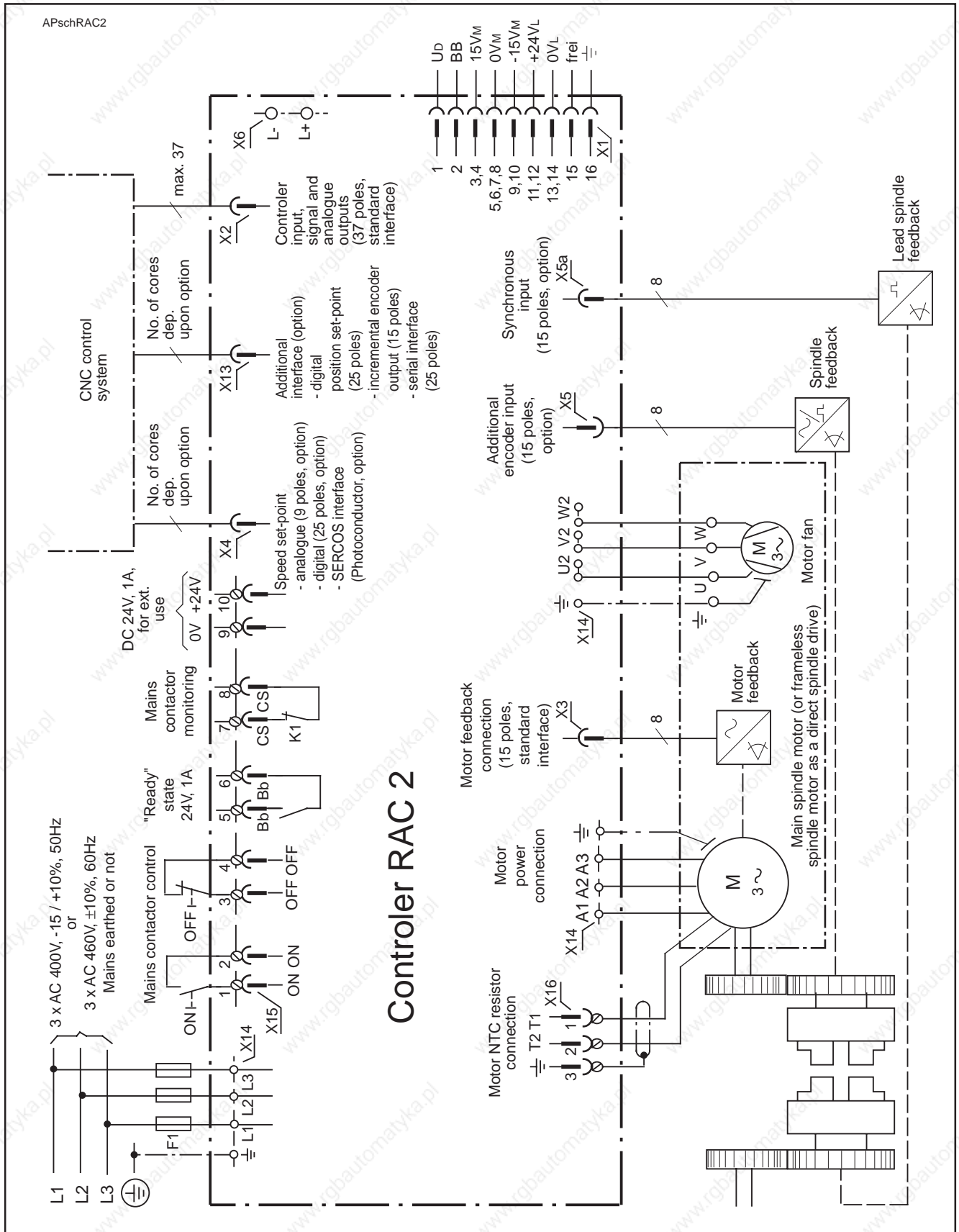

Figure 2.13: Schematic drawing of the RAC 2 connection plan

## 2. Planning the Control Cabinet

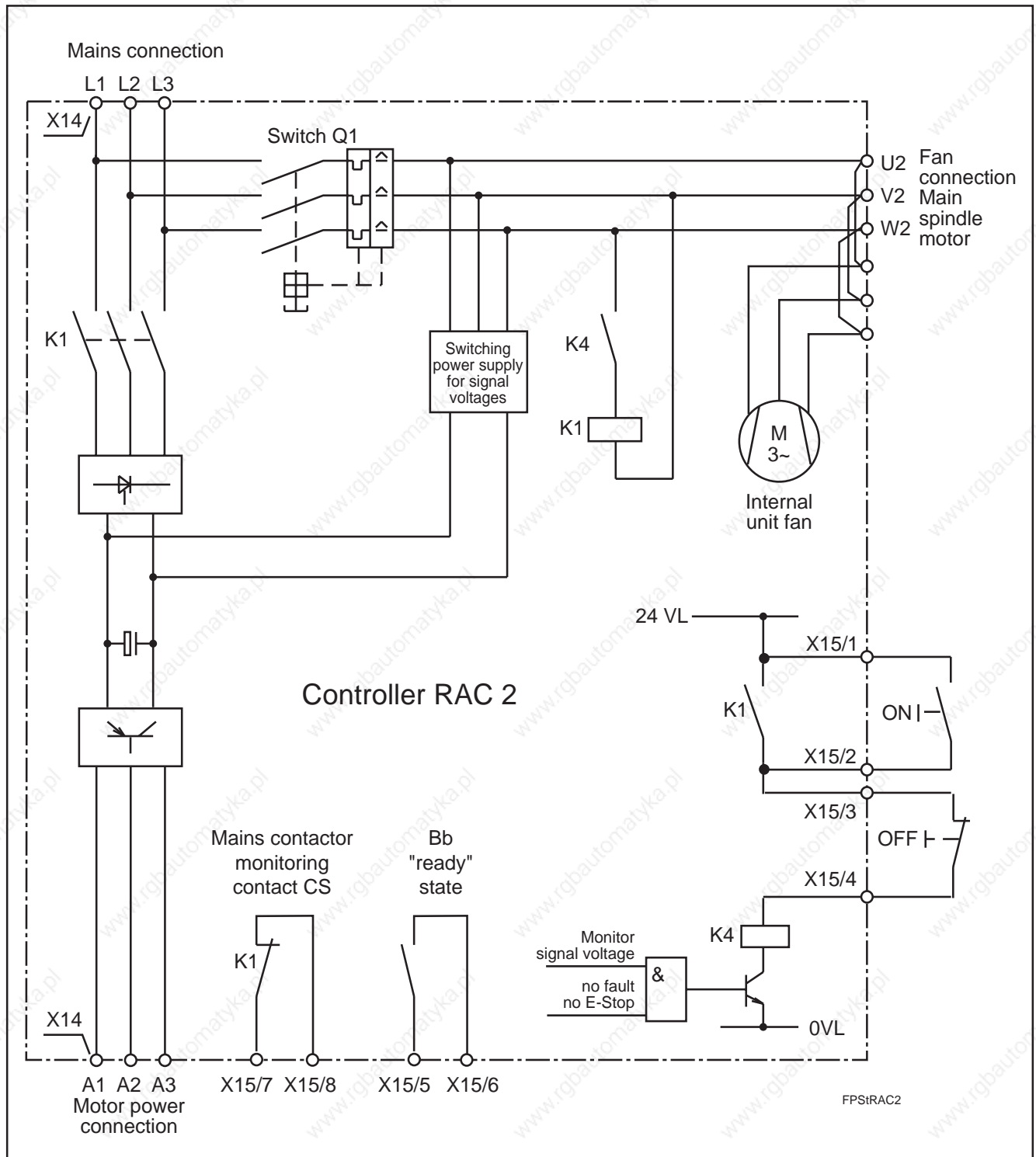

Figure 2.14: Principle circuit diagram of the RAC 2 control circuit and power supply

See documentation for Bb „ready“ state conditions.

„AC Main Spindle Drives with Controlled Asnyhconous Motor or Frameless Spindle Motor-Description of Application“, doc. no. 209-0041-4109.

### Feedback and CNC Connections

Assignment and designation of terminals are the same for all interfaces of all feedback and CNC connections independent of the main spindle controller. They can be found in the document: „Electrical Connections of the Main Spindle Drives“ (doc. no. 209.0042.4111) and in „AC Main Spindle Drives with Controlled Asynchronous Motor or Frameless Spindle Motor; Description of Application“ (doc. no. 209-0041-4109).

Both the function and the signal level linked to this interface are also the same independent of the main spindle controller. They can be found in the latter documentation.

The required electrical connections are dependent upon

– the selected functional options of the controller.

The interfaces found in every main spindle controller (standard interfaces) are allocated to the respective connection plan with the use of a text string. Figure 2.15 depicts this allocation. Figure 2.16 depicts the allocation of the functional options of the controller to the respective connection plan with the use of a text string.

The connection plans for the feedback and CNC connections can easily be located with the use of the text string (last column of Figs. 2.15 and 2.16) in the documentation entitled „Electrical Connections of the Main Spindle Drive; Project Planning Notes“. The index at the end of this documentation lists these text strings.

Type Designation: **RAC 2.2- ●●●-●●●-●●●-●●●**

see doc.  
"Electr. Connections  
of the Main  
Spindle Drives"

Standard interfaces	Designation	Connecting terminal	Text string
CNC interfaces	Controller input, signal and analogue outputs	X2, 37 poles	IKS 610
Feedback interface	Motor feedback connection	X3, 15 poles	IKS 315

Figure 2.15: Allocation of standard interfaces to the connection plans of the feedback and CNC connections.

Type Designation: **RAC 2.2- ●●●-●●●-□□□ - ●●**

functional options

Circuit diagram  
see doc.  
"Electr. connections  
of the Main  
Spindle Drive"



Functional options	Codes	Designation	Connecting terminal	Text string
 Speed set-point value input (type key field 6)	A	analogue	X4, 9 poles	IKS 613
	D	digital 16 bit parallel	X4, 25 poles	IKS 612
	L	SERCOS-interface	X4, optical waveguides	IKO
 Additional encoder input (type code field 7)	O	without additional encoder input		
	P Y	with additional encoder	X5 — with high-resolution <b>INDRAMAT</b> encoder (↷)	IKS 312
		incremental encoder with 15 poles (↷)	IKS 327	
		synchronous input	X5a, 15 poles (↷)	lead spindle feedback
 Additional interface (type code field 8)	O	none		
	D	digital position set-point	X13, 25 poles	IKS 612
	I	incremental encoder output	X13, 15 poles	IKS 323
	S	serial interface RS 232-C	X13, 25 poles	IKS 016

Figure 2.16: Allocation of the functional options of the controller to the electrical connections on the unit and the connecting plans for feedback and CNC connections

Controller-Specific Connections

There are specific plug-and-socket connections for integrating the controller into the control cabinet circuitry and for connecting the NTC-resistor of the motor. They are included in electrical connecting accessories E1-RAC.

The electrical connecting accessories consist of the following parts:

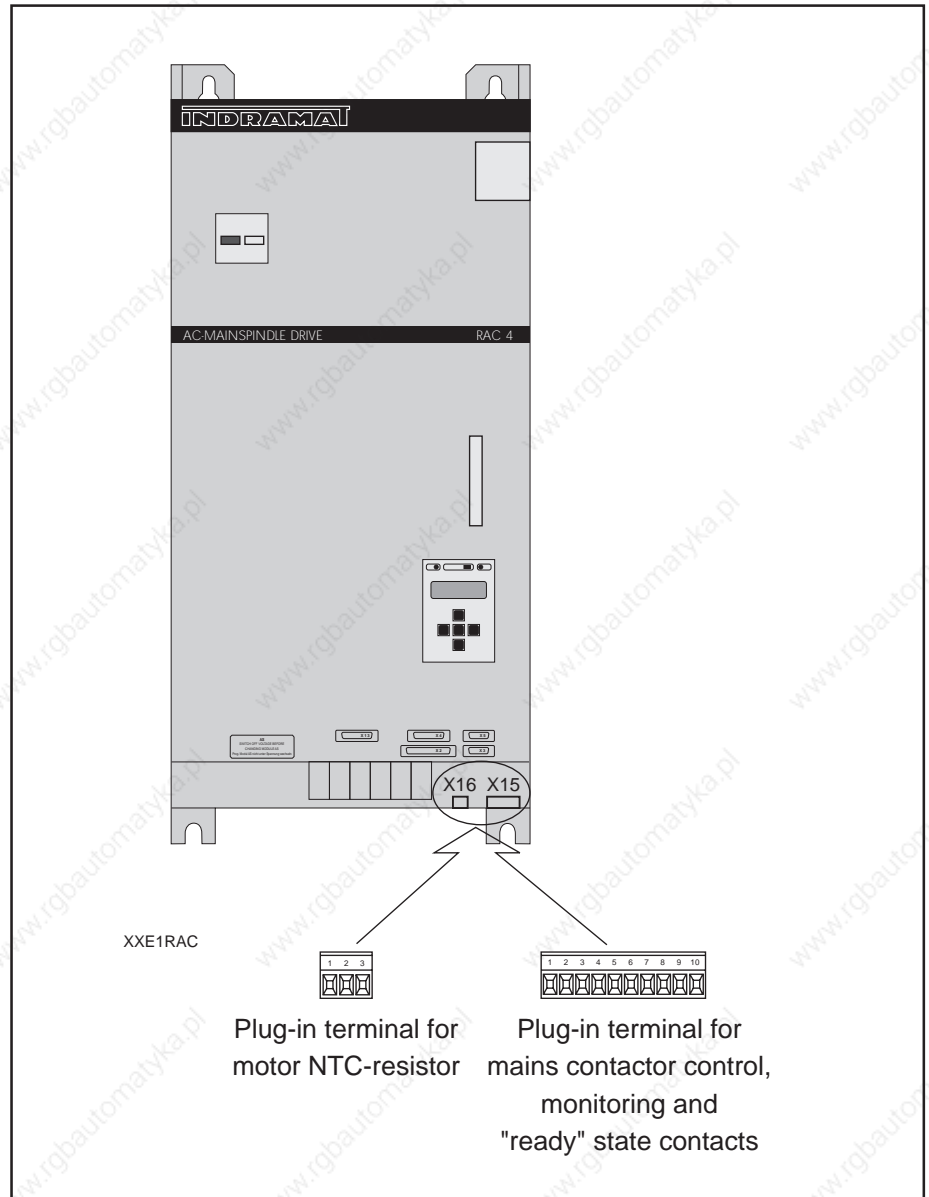

Figure 2.17: E1-RAC Electrical Connecting Accessories

Power connections to the motor

Connection plans and conductor cross sections can easily be located using the text string (last column of Figure 2.18) listed in the document: „Electrical connections of the main spindle drives; Project Planning Notes“. The index of this document lists this text string.

The conductor cross sections are dependent upon the motor rated current of drives which permit motor overload over short periods of operation.

Drive combination: RAC 2.2 - ●●● - ●●● - ●●● - ●●●	
with ...	
...main spindle motor	Circuit plan see doc. "Elec. Conn. of the Main Spindle Drive" text string
2AD 160 B 2AD 160 C	Connection 2AD 160
2AD 180 C 2AD180 D	Connection 2AD 180
1MB 310 D 1MB 310 F 1MB 375 B	Connection 1MB on RAC

Figure 2.18: Allocation of the Main Spindle Motors in the Power Connection Plan

The smaller values can be used for dimensioning in the case of those motor-controller combinations where the continuous output of the controller is smaller than that of the motor.

See Figure 2.19, „RAC 2 Technical Data“ for continuous controller output with different current types.

Power Connections to the Three-Phase Alternating Current Network

If the mains voltage and the rated connection voltage of the RAC agree, then the controllers can be connected to either grounded or ungrounded three-phase current networks.

The mains connection plans for the different mains types are the same for all RAC controllers (RAC 2, RAC 3, RAC 4). They can be found in the document applicable to all main spindle drives: „Electrical Connections of Main Spindle Drives; Project Planning Notes“ (doc. no. 209.0042.4111). This document contains the data for conductor cross sections, rated fuse currents and any power transformers which might be needed.

**2.5. Technical Data Summary**

Designation	Symbol	Unit	RAC 2.2-200	RAC 2.2-250
<p><b>Cooling</b></p> <p>Rated connection voltage</p> <p>Continuous controller output (as relates to motor output shaft)</p> <p>Peak controller output (as relates to motor output shaft)</p> <p>Continuous regeneration output (as relates to motor output shaft)</p> <p>Peak regeneration output (max. 5 secs.) (as relates to motor output shaft)</p>	<p><math>U_{(AC)}</math></p> <p><math>P_{(cont)}</math></p> <p><math>P_{(max)}</math></p> <p><math>P_{(reg)}</math></p> <p><math>P_{(reg,max)}</math></p>	<p>V</p> <p>kW</p> <p>kW</p> <p>kW</p> <p>kW</p>	<p>via built-in fan</p> <p>380V-type: 3 x AC 400 V, 50-60Hz, -15/+10%</p> <p>460V-type: 3 x AC 400 V, 50 Hz, <math>\pm 15\%</math> or 3 x AC 460 V, 60 Hz, <math>\pm 10\%</math></p> <p>55</p> <p>55</p> <p>37</p> <p>55</p>	<p>65</p> <p>78</p> <p>43</p> <p>78</p>
<p><b>Weights</b></p> <p>Weight of controllers</p> <p>Weight of mounting frame M1-RAC4</p> <p>Weight of accessories M2-RAC (hose cooling)</p>	<p>m</p> <p>m</p> <p>m</p>	<p>kg</p> <p>kg</p> <p>kg</p>	<p>121</p> <p>2</p> <p>1,7</p>	
<p><b>Environmental conditions</b></p> <p>Perm. ambient temperature range with rated data</p> <p>Max. perm. ambient temperature range with rated data reduced to 80%</p> <p>Storage and Transport Temperatures</p> <p>Installation altitudes without reduction of rated data</p> <p>Perm. humidity in acc. with humidity category</p> <p>Type of protection</p>	<p><math>^{\circ}</math>Celsius</p> <p><math>^{\circ}</math>Celsius</p> <p><math>^{\circ}</math>Celsius</p> <p>m above sea level</p>	<p><math>^{\circ}</math>Celsius</p> <p><math>^{\circ}</math>Celsius</p> <p><math>^{\circ}</math>Celsius</p> <p>m above sea level</p>	<p>+5 ... +45</p> <p>+55</p> <p>-30 ... +85</p> <p>max. 1000</p> <p>F acc. to DIN 40 040</p> <p>IP 10 acc. to EN 60 529 (DIN VDE 0470)</p>	

Figure 2.19: RAC 2 Technical Data

## 2.6. Type Codes

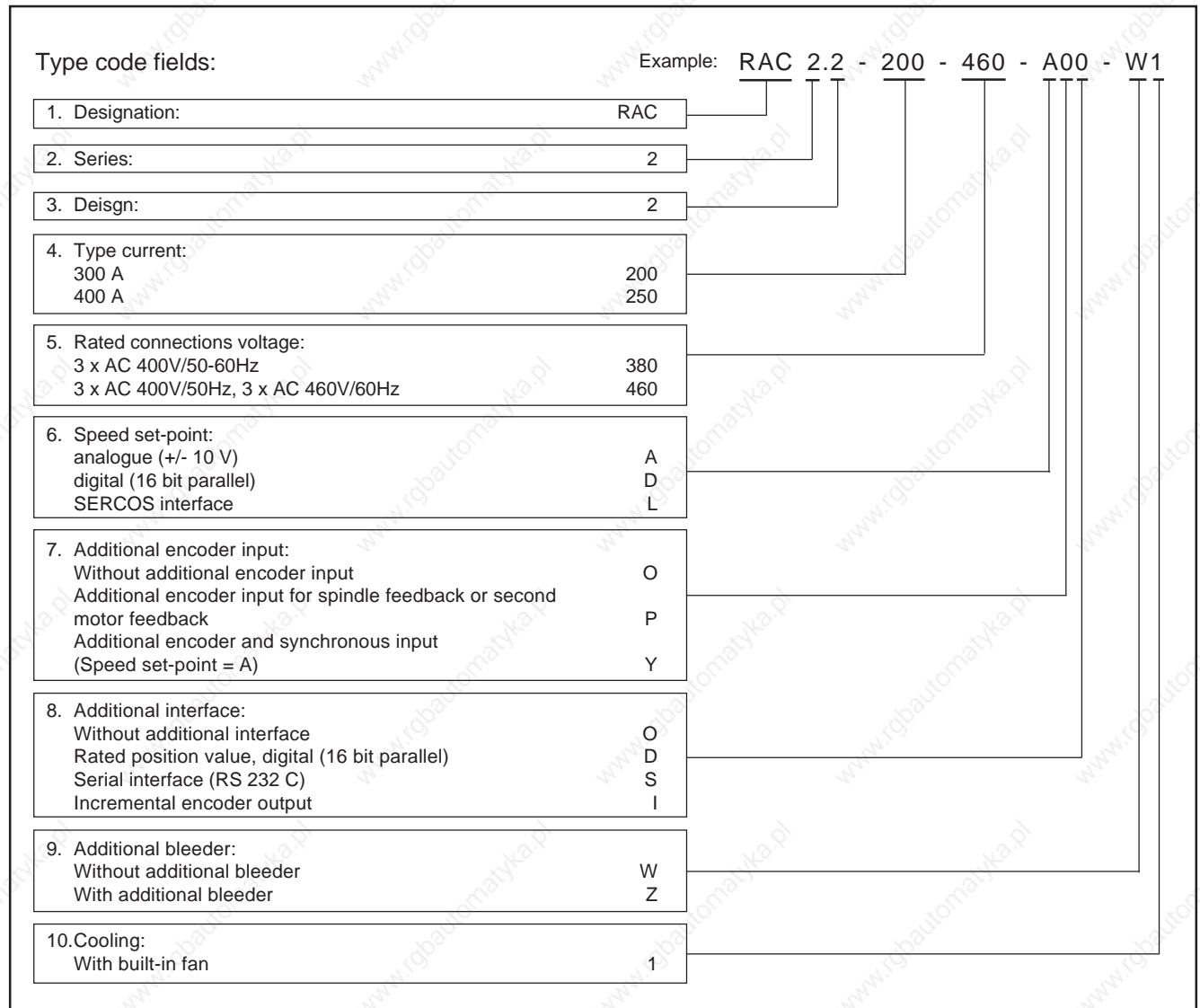

Figure 2.20: Type Codes for RAC 2

### 3. AS Programming Module

The AS programming module plugged into the controller adapts the controller to the main spindle motor and implements the operating characteristics of the main spindle drive.

INDRAMAT supplies a matching AS programming module (standard delivery acc. to selection list) for every main spindle drive offered.

INDRAMAT main spindle drives are microprocessor controlled.

#### Quick Drive Commissioning

A matching AS programming module means that the main spindle drive will be ready with the first run without any adjustment work. Expert connection work (see Chap. 2.4) and proper commissioning are prerequisites (see Chap. 9).

INDRAMAT main spindle drives can be adapted via the parameters to the facility situation and the functional demands of the application.

#### Advantages derived from exchange of units

The AS programming module contains both software and parameters. Should a unit need to be exchanged, then the controller requires no additional adjusting. It is immediately matched to both motor and facility by simply plugging the programming module – thus far used and therefore already matched – into it.

#### Duplicating

Already adapted programming modules can be easily duplicated for additional, similar machines. This is done either with the parameter duplicating adaptor or by means of serial interfaces and a storage device (PC or something similar).

#### Parameters

The software contains two groups of parameters:

- drive-related and
- application-related parameters.

The drive-related parameters affect the operating characteristics of the drive. INDRAMAT defines and fixes the appropriate parameter values which implement the operating characteristics of the drives offered.

The drive-related parameters activate or affect, according to application, the functions of the main spindle drive, and the drive is adapted to the facility's application.

#### Input and Change of Parameter Values

Input and change of parameter values is the same in all INDRAMAT main spindle controllers. The task is performed using the keypad on the control panel.

For further information, please see the chapter on „Using the Controller“ in document „AC Main Spindle Drives with Controlled Asynchronous Motor or Frameless Spindle Motor; Description of Application“, (doc. no. 209-0041-4109).

### 3.1. AS Programming Module Design

AS programming modules contain the application-related parameter values defined by INDRAMAT.

#### Standard

The application-related parameters are set to standard values. The facility or the application-dependent parameter values are input on site.

The customer is responsible for documentation and administration of these facility and application-dependent parameter values.

#### Customer-Specific Values (for larger series)

If, after facility and applications-dependent parameter values have been input, a programming module is also to be documented, administered and delivered by INDRAMAT in this condition, then it becomes necessary to define a customer-specific programming module. This can be done upon request in agreement with INDRAMAT for an additional fee.

### 3.2. AS Programming Module Compatibility

A state-of-the-art (updating programming module AS) programming module for the operation of the drive is automatically part of a delivery without a change in order specifications being necessary (type designation). Updated programming modules are compatible with programming modules already delivered.

#### Updating AS Programming Modules

It is not necessary to make any changes in an order as there should be no doubt that the drive being operated is state-of-the-art.

This means:

- software fault correction,
- expansion of the range of functions without impairing existing functions, and,
- improved parameter values for the motor-controller combination.

### 3.3. Type Plate Information

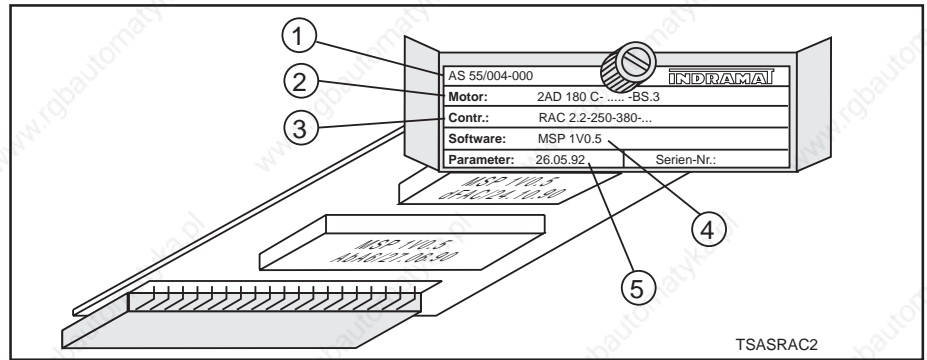

Figure 3.1: AS Programming module with type plate specifications

#### ① Type designation

The final digits of a standard design programming module are -000. The final digits of customer-specific programming modules are the customer-specific digits assigned by INDRAMAT.

#### ② Motor type data

#### ③ Drive controller type data

The type data for motor and controller found on the programming module must agree with that of the motor and controller installed, as otherwise there is risk of damage!

#### ④ Software designation

The letter-digit combination, including the letter „V“, indicate the type of software with version. The digits that follow are the counter digits of the software update.

#### ⑤ Date parameters determined

This helps determine parameter status.

### 3.4. Type Code

Type code fields:	Example:	AS 53/004-003
1. Designation:	AS	AS
2. Main spindle drive controller KDA 3.2 RAC 2.2 RAC 3.1 TDA 1.1 RAC 4.1	3 5 6 7 8	53
3. Software coefficient Main spindle drive (standard) (all combinations not listed below) Servo-drive (always includes incremental encoder output) Main spindle drive with incremental encoder output Main spindle drive with SERCOS interface Main spindle drive with additional functions	1 2 3 4 5	004
4. Motor feedback High-resolution motor feedback	0	0
5. Coefficient for motor-controller combination Defined and documented by INDRAMAT	e.g., 04	00
6. Design Standard Customer-specific, e.g.,: 003	000 003	003

Quellverweis: INN 07.20

Figure 3.2: Type codes for AS programming modules

## 4. Condition Upon Delivery

The RAC 2 and its accessories are packed into one carton (transport container) for delivery. Accessories have been screwed onto the unit (M1-RAC2), or packed into plastic bags loosely placed in the cartons (possibly M2-RAC 4 and E1-RAC).

An envelope containing two delivery slips is attached to the outside of the transport container. There are no additional accompanying documents unless specifically requested.

By splitting the glue strips open, it is possible to unpack without causing damage.

The cooling method of the RAC 2 controller as generally supplied is the control cabinet outside air type (see Chapter 1). Current and insulation have been tested in acc. with VDE 0160.

## 5. Identification of Hardware

A delivery slip in duplicate is attached to the transport container. The listed contents of the delivery are distributed over several cartons (transport containers). This is noted on either the delivery slip or the bill of lading.

The delivery slip lists the merchandise by designation and order designation.

In the case of mixed orders, individually packed controllers and accessories are packed into the transport containers. With multiple-orders of the same units, the accessories might be found in a separate transport container.

### Main Spindle Controller RAC 2

There is a barcode sticker on the RAC 2 packaging. It identifies contents in terms of design and order handling.

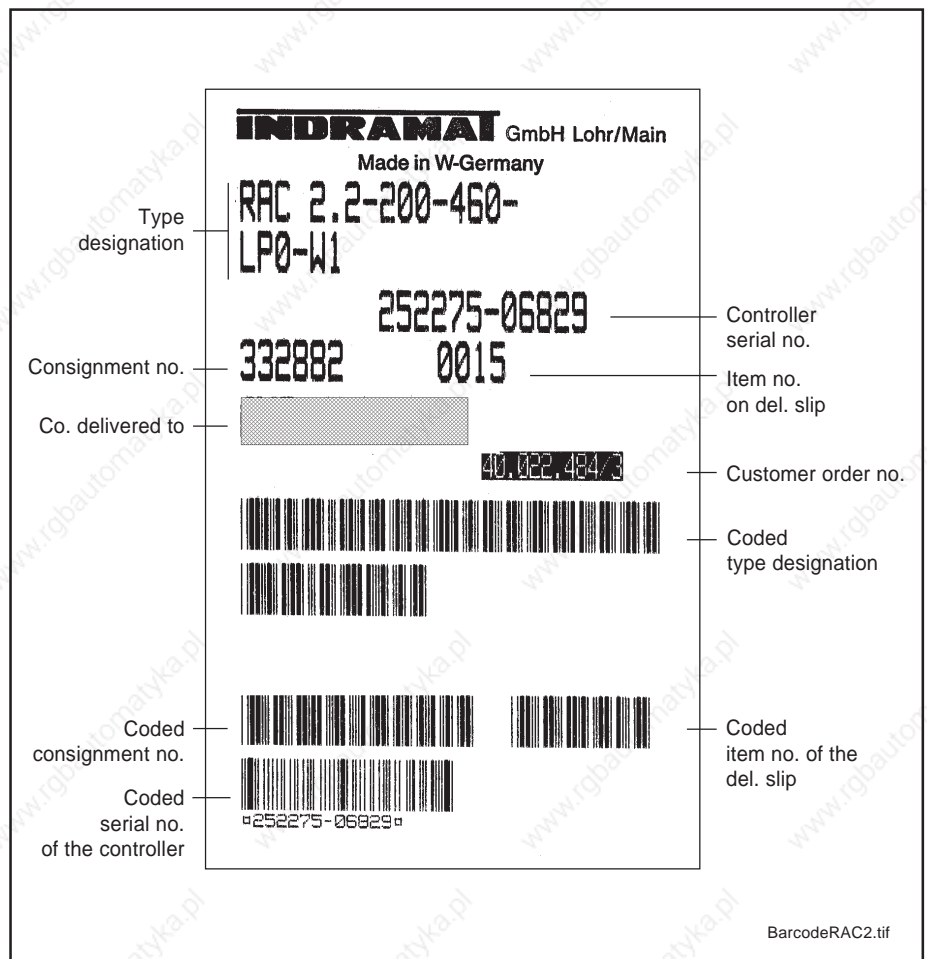

Figure 5.1: Barcode sticker on the RAC packaging (example)

A sticker is located on the side of the RAC 2 itself. It contains all necessary information in the event that servicing should be necessary. It corresponds to the barcode sticker and contains all delivery information (see Figure 5.2).

The type plate (see Fig. 5.3) is located on the lower left side of the inside of the RAC 2 housing.

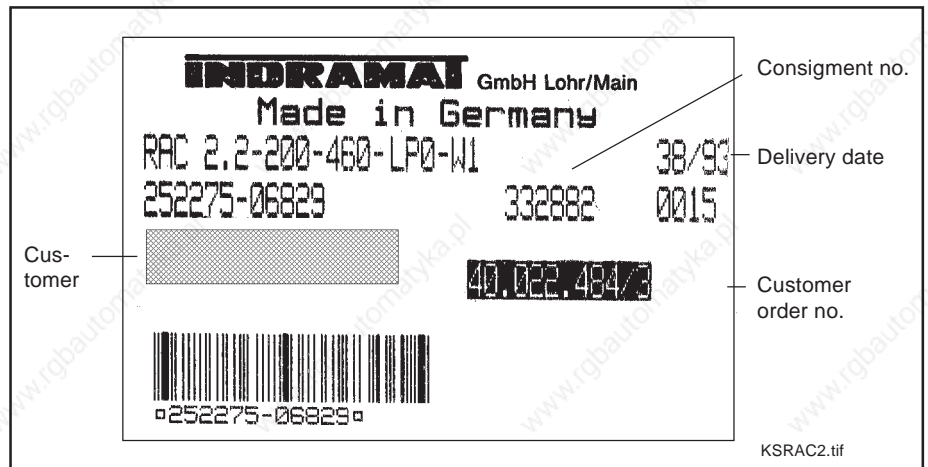

Figure 5.2: Service sticker (on the side of the unit, example)

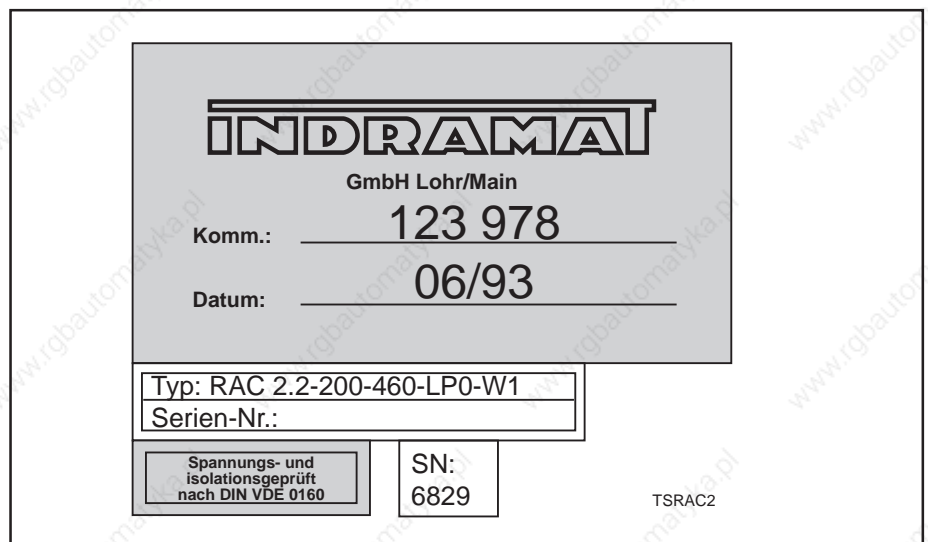

Figure 5.3: RAC 2 type plate (on inside left side wall)

### AS Programming Module

Programming modules are always packed individually in plastic bags and then, additionally, in a carton.

There is a barcode sticker on the side of the carton on which the individual data is additionally printed in text form (Figure 5.4).

The plastic bag protects the AS programming module against static loads.



**Touching the printed circuit board can cause damage!**

The parameter list is in the plastic bag with the programming module. It contains all the data about the programming module and documents the parameter values set at delivery.

If the parameter values should, for example, be lost upon commissioning, it is then possible to manually input the original values, taking them from the parameter list. The parameter list should be put in the machine file!

There is a type plate on the front of the programming module (see Fig. 3.1).



Figure 5.4: Barcode sticker on programming module carton

## Accessories

The electrical accessories are packed in plastic bags with order information manually written on them.

Mechanical accessories M1-RAC 2 (mounting frame) are screwed onto the backwall of the controller.

Mechanical accessories M2-RAC 2 (optional hose cooling method) is delivered in a separate carton. It contains four flanges (unpacked) and all the screws (in a plastic bag) which will be needed to attach hose cooling. „M2-RAC 2“ is written on the outside of the carton. The hose is not automatically part of the general delivery!

## 6. Storage and Transport

The controller must be kept dry, stored dust and impact free. The permissible ambient temperature range is from -30 degrees to +85 degrees C.

In the event of the danger of excessive vibrations, use a vibration-damping base during transport!

Transport tips on the packaging:



Figure 6.1: Safety tips for transport

## 7. Mounting

### Condition Upon Delivery

The controller is standardly delivered with a cooling system which uses control cabinet outside air. If this should not agree with the cooling method intended in the machine, then structural changes become necessary. This should be done before the controller is built into the control cabinet because of screw access.

### Structural Alterations to Accomodate Control Cabinet Inside Air Cooling

- Remove lid of cooling housing (1) (snap attachment)
- Detach lower skin plate of heatsink (2) by removing the fixing bolt. The screws are easily accessible from the underside of the controller.
- Remove cooling baffle (3) at the lower end of the heatsink. The fixing screws can only be reached from the back side of the controller!

A mounting plate without cut-outs should be used for cooling with control cabinet inside air.

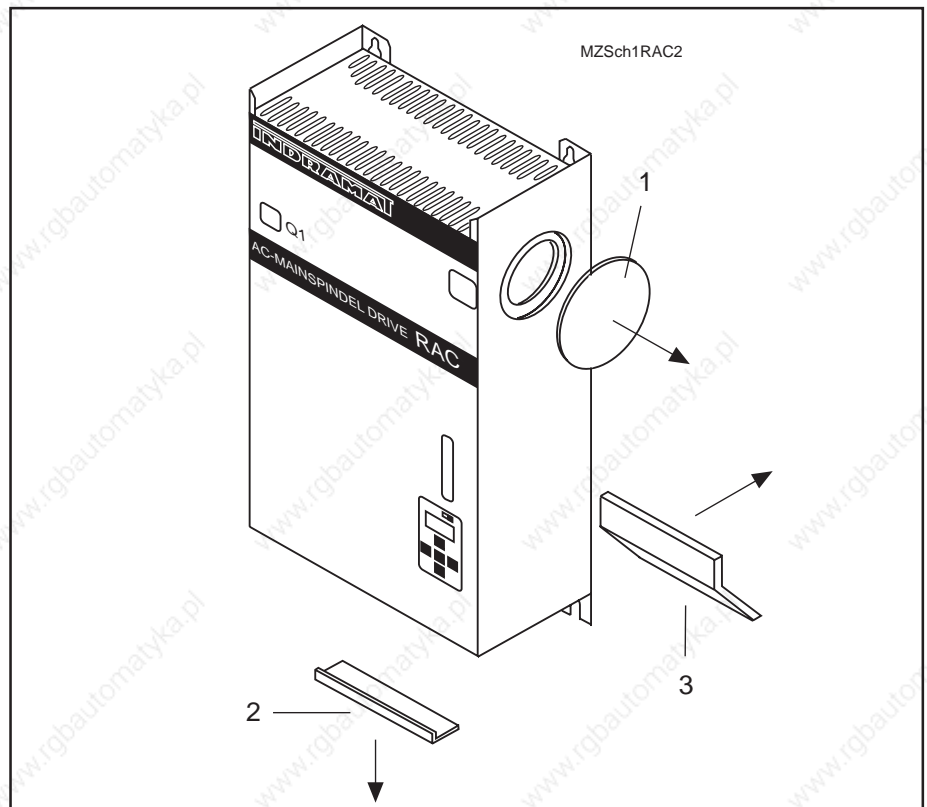

Figure 7.1: Structural changes for control cabinet inside air cooling.

### Structural Changes to Accomodate Hose Cooling

- Remove lid of cooling housing (1) (snap attachment)
- Detach lower skin plate of heatsink (2) by removing fixing bolt. The screws are easily accessible from the underside of the controller.
- Remove cooling baffle (3) at lower end of heatsink. The fixing screws can only be reached from the back of the controller!
- Assemble the hose cooling accessories (4) in accordance with the supplied plans for structural alteration (drawing no. 9.588.052.3-00).

An assembly plate without cut-outs should be used for hose cooling here as well.

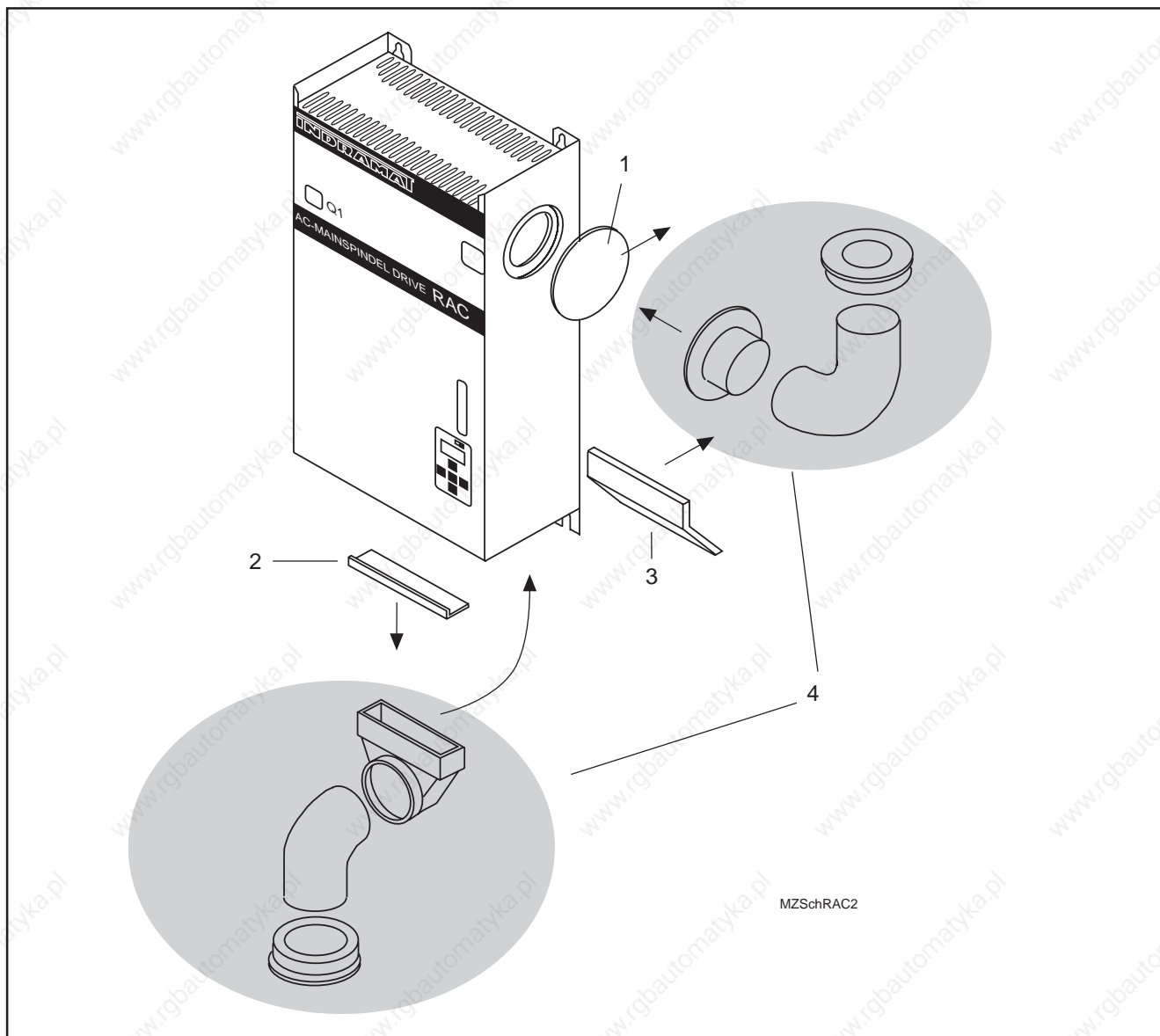

Figure 7.2: Structural alterations for hose cooling

### 7.1. Mounting the Drive Controller in the Control Cabinet

The following parts are needed for mounting into the control cabinet:

- mechanical mounting accessories M1-RAC 2
- RAC 2 controller
- lifting equipment (weight RAC 2 = 121 kg)

The control cabinet should accordingly be prepared for the intended cooling method.

#### Installing the Mounting Frame for the Controller

Remove the mounting frame from the backwall of the controller. Using the screws supplied, fix it to the backwall of the control cabinet or mounting plate. The mounting frame is located behind the control cabinet wall or mounting plate. The screws for fixing the controller should be screwed in so far that they cannot fall out.

The mounting frame serves to reinforce the backwall of the control cabinet or mounting plate and creates a level surface for the flat gasket ring on the controller. It carries all threads and sealing rings that are needed to secure support for itself and the controller, and to guarantee the sealing of the control cabinet (see „Category of Protection“, Chapter 2.1).

## Mounting the Controller

Lift the controller into its position in the control cabinet with the use of lifting equipment (a crane or something similar), and hang it onto the already mounted screws. Tighten the screws firmly into place.

## Installing the Controller

The socket for the programming module is located on the left on the lower edge of the front plate of the RAC 2. The programming module is pushed into this socket and then secured with a knurled screw!



**Before commissioning the RAC 2, plug in the programming module and secure it with a knurled screw.**

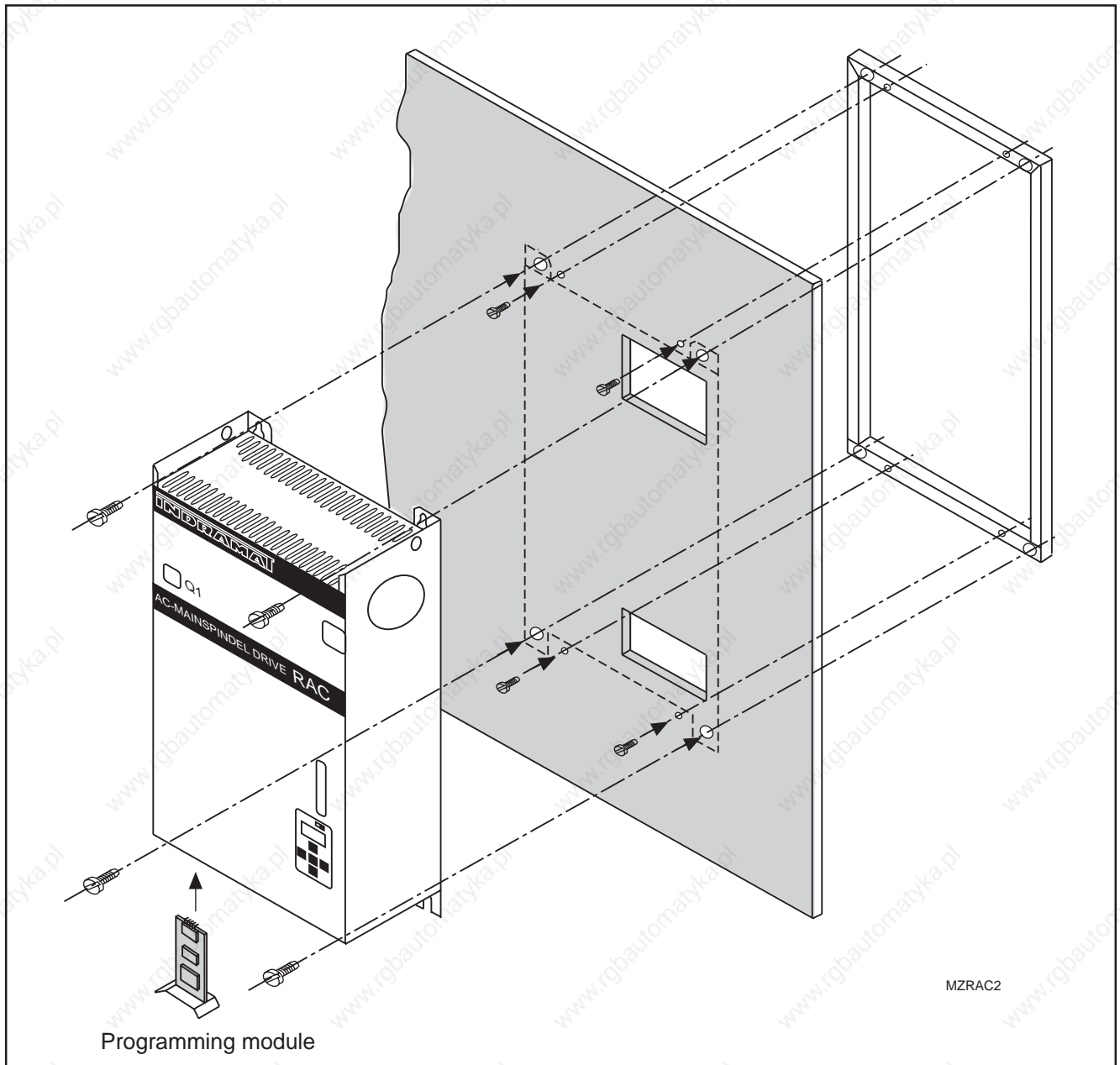

Figure 7.3: Installing the RAC 2

## 8. Installation Guidelines

- The wiring diagrams of the machine manufacturer must be followed when wiring the facility!
- INDRAMAT connection plans see „Electrical Connections of Main Spindle Drives; Project Planning Notes“, (doc. no. 209-0042-4111) must be used when developing the facility wiring plans.
- The power connections safety guards on the front side of the unit must be in place before the unit is turned on and commissioned!
- The D-sub-plug-and-socket connection must be firmly screwed into place upon commissioning!
- The unit should be shut down prior to removing the AS programming module. The knurled screw must be firmly screwed into place during operation!
- The power cable cores must be twisted!
- The motor must be grounded on the controller!

## 9. Commissioning Guidelines

Commissioning procedures are identical for all main spindle controllers (RAC 2, RAC 3, RAC 4). For this reason, and because of the extensive range of functions, this procedure is explained only once in the INDRAMAT main spindle drive document and valid for them all, namely, in the document entitled „AC Main Spindle Drive with Controlled Asynchronous Motors or Frameless Spindle Motor, Description of Application“ (doc. no. 209-0041-4109).

## 10. Servicing Guidelines

### 10.1. Fault Diagnosis

The RAC 2 diagnosis drive faults via the display located on the control panel. In the event of a fault, the drive brakes until it is standing still, at which point the RAC 2 then shuts power down. The fault diagnoses of the different main spindle controllers are the same.

The fault diagnoses and fault recovery guidelines are, therefore, described in the document entitled „AC Main Spindle Drives with Controlled Asynchronous Motors or Frameless Spindle Motor Description of Application“, (doc. no. 209-0041-4109). It is valid for all INDRAMAT main spindle drives.

### 10.2. Defective Controllers

As a result of the excessive weight of the controller, its exchange is only possible with the use of suitable lifting equipment (crane or something similar). In most cases, any occurring problem is repaired on location.

Should an exchange become necessary, then the drive can be adapted without any problem by unplugging the existing programming module from the defective controller and plugging it into the replacement controller. The RAC2 is matched to the drive and machine via parameters. These parameters are stored on the AS programming module. The drive with the new controller and existing programming module now operates in the same manner as the original drive.

#### Repairs

Should the controller not work because of a fault, then this procedure must be followed:

- The master switch must be accessed and secured against switching back on before any work can be performed on the electrical equipment.
- Only INDRAMAT customer service personnel or comparably trained personnel should be permitted to repair the equipment!

#### Controller Exchange

- All connections should be released and removed prior to exchanging equipment. The fixing screws should be released and lifting equipment should be used to remove the RAC 2 from the control cabinet.
- Lifting equipment should also be used to lift the replacement back into the control cabinet. Remove the programming module from the defective unit, plug it into the replacement and, using the knurled screw, secure it against falling out.



**Do not remove or plug in the programming module with power on! The fixing bolt on the programming module must be tightly screwed into place when the RAC 2 is in operation!**

## 10. Servicing Guidelines

---

### Returning a Faulty Controller

- Connect the new RAC 2 in accordance with the wiring plans.
- Assume operation (see document, „AC Main Spindle Drive with Controlled Asynchronous Motor or Frameless Spindle Motor, Description of Application“), (doc. no. 209-0041-4109), the chapter on commissioning.
- Fill out the return card for return of equipment/trouble protocol! A sample of this card is depicted in Figure 10.1. It can be copied and used for your convenience.
- Return faulty equipment with the return card to the appropriate INDRAMAT service representative!

<b>Repair Card for INDRAMAT equipment and components</b>			
Completed by: _____		Company/Town: _____	
Date: _____			
When replacing single components, enter component designation		SN: _____	Supply job no.: _____
		SN: _____	Shipment date: _____
Machine manufacturer/Company: _____	Type: _____	Machine no.: _____	if necessary - commissioning date _____
Fault in axis no. _____	<input type="checkbox"/> horizontal <input type="checkbox"/> vertical <input type="checkbox"/>	Operating hours: _____	Date fault occurred: _____
<b>Fault status:</b> Fault _____ _____ <input type="checkbox"/> always present <input type="checkbox"/> occurs sporadically <input type="checkbox"/> occurs after _____ hrs <input type="checkbox"/> occurs on impact/vibration <input type="checkbox"/> is temperature-dependent <input type="checkbox"/> other * _____ * _____ * _____	<b>Additional information:</b> (e.g. LED diagnosis messages in display) _____ _____ _____ _____ _____ _____	<b>Cause of fault:</b> <input type="checkbox"/> not known <input type="checkbox"/> fault connection <input type="checkbox"/> ext. short-circuit <input type="checkbox"/> mech. damage <input type="checkbox"/> loose cable connections <input type="checkbox"/> other * _____ * _____ * _____	
Supplementary information			
<b>General details:</b> <input type="checkbox"/> no function <input type="checkbox"/> drive running irregularly <input type="checkbox"/> uncontrolled drive motion <input type="checkbox"/> fault in only one direction <input type="checkbox"/> burnt-out fuse on supply <input type="checkbox"/> other	<b>Related incidents:</b> <input type="checkbox"/> mechanical problems <input type="checkbox"/> failure of power supply <input type="checkbox"/> failure of controller <input type="checkbox"/> motor failure <input type="checkbox"/> cable break <input type="checkbox"/> other	<b>Controller, supply unit, amplifier, mains power:</b> <input type="checkbox"/> faulty control voltage <input type="checkbox"/> mains power fuse burnt out <input type="checkbox"/> defective fan <input type="checkbox"/> defective bleeder resistor <input type="checkbox"/> faulty power supply voltage <input type="checkbox"/> connection bolt sheared off <input type="checkbox"/> other	
<b>Control system:</b> <input type="checkbox"/> no function <input type="checkbox"/> faulty display <input type="checkbox"/> no set-point output <input type="checkbox"/> diagnosis <input type="checkbox"/> dimensional shift in direction <input type="checkbox"/> E-STOP circuit broken <input type="checkbox"/> pos. control loop does not close <input type="checkbox"/> programme sequence fault <input type="checkbox"/> faulty internal auxiliary function (outputs) <input type="checkbox"/> acknowledgements not accepted (inputs) <input type="checkbox"/> other _____ _____ _____	<b>Motor:</b> <input type="checkbox"/> defective thermocouple <input type="checkbox"/> defective brake <input type="checkbox"/> defective fan <input type="checkbox"/> defective feedback <input type="checkbox"/> defective speed encoder signal <input type="checkbox"/> defective BLC signal <input type="checkbox"/> earthing short-circuit <input type="checkbox"/> overheating <input type="checkbox"/> other _____ _____ _____ _____	<b>Remarks:</b> _____ _____ _____ _____ _____ _____	

Fig. 10.1: Repair-Card

## 10.3. Service Representatives

GERMANY	ITALY	NETHERLANDS
<p>Lohr:</p> <p>Indramat GmbH Bgm.-Dr.-Nebel-Str. 2 D - 97816 Lohr am Main Telefon 0 93 52/40-0 Telex 6 89 421 Telefax 0 93 52/40-4885</p>	<p>Rexroth S.p.A. Divisione Indramat Via G. Di Vittorio, 1 I - 20 063 Cernusco S/N. MI Telefon 02/9 23 65 - 270 Telex 331 695 Telefax 02/92 10 80 69</p>	<p>Hydraudyne Hydrauliek B.V. Kruisbroeksestraat 1a P.O.Box 32 NL - 5280 AA Boxtel Telefon 04 116/51 951 Telefax 04 116/51 483</p>
<p>Chemnitz:</p> <p>Indramat GmbH c/o Rexroth Vertriebs- und Servicegesellschaft mbH Beckerstraße 31 O - 09120 Chemnitz Telefon 03 71/355-0 Telefax 03 71/355-225</p>	<p>ENGLAND</p> <p>G.L. Rexroth Ltd. Indramat Division 4 Esland Place, Love Lane Cirencester, Glos GL 7 1 YG Telefon 02 85/65 86 71 Telex 43 565 Telefax 02 85/65 49 91</p>	<p>SWEDEN</p> <p>AB Rexroth Mecman Indramat Division Vuravägen 7 S - 125 81 Stockholm Telefon 08/727 92 00 Telefax 08/99 75 15</p>
<p>Düsseldorf:</p> <p>Indramat GmbH Technisches Büro Ratingen Harkortstraße 25 Postfach 32 02 D - 40880 Ratingen Telefon 0 21 02/44 20 48 /-49 Telefax 0 21 02/41 315</p>	<p>AUSTRIA</p> <p>G.L. Rexroth GmbH Geschäftsbereich Indramat Randlstraße 14 A - 4061 Pasching Telefon 07 229/44 01-36 Telefax 07 229/44 01-80</p>	<p>SPAIN</p> <p>Rexroth S.A. Centro Industrial Santiga Obradors s/n E-08130 Santa Perpetua de Mogoda (Barcelona) Telefon 03/7 18 68 51 Telex 59 181 Telefax 03/718 98 62</p>
<p>FRANCE</p> <p>Rexroth - Sigma Division Indramat Parc des Barbanniers 4, Place du Village F - 92632 Gennevilliers Cedex Telefon 1/47 98 44 66 Telex 616 581 Telefax 1/47 94 69 41</p>	<p>REPUBLIC OF SLOVENIA</p> <p>Domel Otoki 21 SLO - 64 228 Zelezniki (Slowenien) Telefon 064/66 441 Telefax 064/ 673 49</p>	<p>Goimendi S.A. División Indramat Jolastokieta (Herrera) Apartado 11 37 San Sebastian, 20 017 Telefon 043/40 01 63 Telex 36 172 Telefax 043/39 93 95</p>

Fig. 10.2: Service Representatives

USA	KOREA	AUSTRALIA
<p>Rexroth Corporation            Indramat Division            255 Mittel Drive            Wood Dale, Illinois 60 191            Telefon 708/8 60 - 10 10            Telefax 708/5 30 - 46 31</p>	<p>Seo Chang Corperation Ltd.            44 - 35 Yeouido-Dong            Yeongdeungpo Ku            Seoul, Korea            Telefon 02/780 - 82 08 ~9            Telex K 22 686 SCCLTD            Telefax 02/784 - 54 08</p>	<p>Australian Machine Tool            Co. Pty. Ltd.            9 Webber Parade            East Keilor (Melbourne)            Victoria, 3033 Australia            Telefon 03/336 78 22            Telefax 03/336 17 52</p>
<p>Rexroth Corporation            Indramat Division            2110 Austin Avenue            Rochester Hills, Michigan 48 309            Telefon 313/853 - 82 90            Telefax 313/853 - 82 98</p>		<p>INDIA</p> <p>G. L. Rexroth Ind. Ltd.            Indramat Division            67/2 Lavelle Road            Bangalore - 560 001            Telefon 08/56 49 43            Telex 08 45 87 12 giril in            Telefax 08/21 49 43</p>
<p>BRAZIL</p> <p>Rexroth Hidráulica Ltda.            Divisão Indramat            Rua Heinrich Passold,130            CP 156            BR - 89. 107 000 Pomerode SC            Telefon 04 73/87 03 21            Telex 47 32 88 REXR BR            Telefax 04 73/87 02 51</p>		

Fig. 10.3: Service Representatives

## 11. Index

### A

Additional encoder input 31  
Additional interface 14, 31  
Allocation of standard interfaces to the connectio 34  
Allocation of the functional options of the contro 34  
Allocation of the Main Spindle Motors in the Power 36  
ambient humidity 18  
Ambient temperature-dependent reductions 17

### B

Bb "ready state" 32

### C

CNC control interfaces 14  
Commissioning Guidelines 51  
Condition Upon Delivery 42  
Connection Plan 30  
Contact safety lid 20  
Control panel 14  
Controler input 31  
Controller Exchange 52  
Controller-Specific Connections 35  
Cooling with Air Inside the Control Cabinet 12  
Cooling with Air Outside the Control Cabinet 12

### D

Defective Controllers 52  
Dimensions for cooling control cabinet with inside 23  
Dimensions for cooling control cabinet with outsid 22  
Dimensions for hose cooling 24  
Dimensions Sheet 20  
Dimensions sheet for hose cooling 25  
Drill diagram 21

### E

electrical connecting accessories 16  
Electrical Data 30  
Environmental Conditions 17

### F

Fault Diagnosis 52  
Feedback and CNC Connections 33  
Feedback interfaces 14

### I

Identification of Hardware 43  
Installation Altitude 18  
Installation Guidelines 50  
Installing the RAC 2 49  
Interface for monitoring and control circuits 14  
Interface Options 15  
Internal unit fan 32

### L

Lead spindle feedback 31

**M**

Main spindle motor 31  
main spindle motor 16  
mains connecting cable 16  
Mains connection 14, 32  
Mains contactor control 31  
mains contactor controls 30  
Mains contactor monitoring contact 32  
motor fan cable 16  
Motor feedback 31  
motor feedback cable 16  
Motor NTC resistor connection 31  
Motor NTC-resistor connection 14  
motor power cable 16  
Motor power connection 14, 31  
Mounting 47  
Mounting frame 16  
Mounting the Drive Controller 48

**P**

Plug-in terminal for motor NTC-resistor 35  
Power connections to the motor 36  
Power Connections to the Three-Phase Alternating C 36  
Power Dissipation 26  
Principle circuit diagram 32  
Programming modul 16  
Programming module 14  
Programming Module AS 39

**R**

RAC 2 controler 16  
Ready state 31  
Repair Card 54  
Repairs 52  
Returning a Faulty Controller 53

**S**

Service Representatives 55  
Signal and analogue outputs 31  
Spindle feedback 31  
Storage and Transport 46  
Structural Alterations to Accomodate Control Cabin 47  
Structural Changes to Accomodate Hose Cooling 47  
Switch Q1 14, 32  
Switching power supply 32  
Synchronous input 31

**T**

Technical Data 37  
Thermal Data 26  
Type Codes 38  
Type codes for AS programming modules 41

**U**

Use of Cooling Devices in Control Cabinets 28

**W**

Weights 37



## Summary of Supplementary Documentation

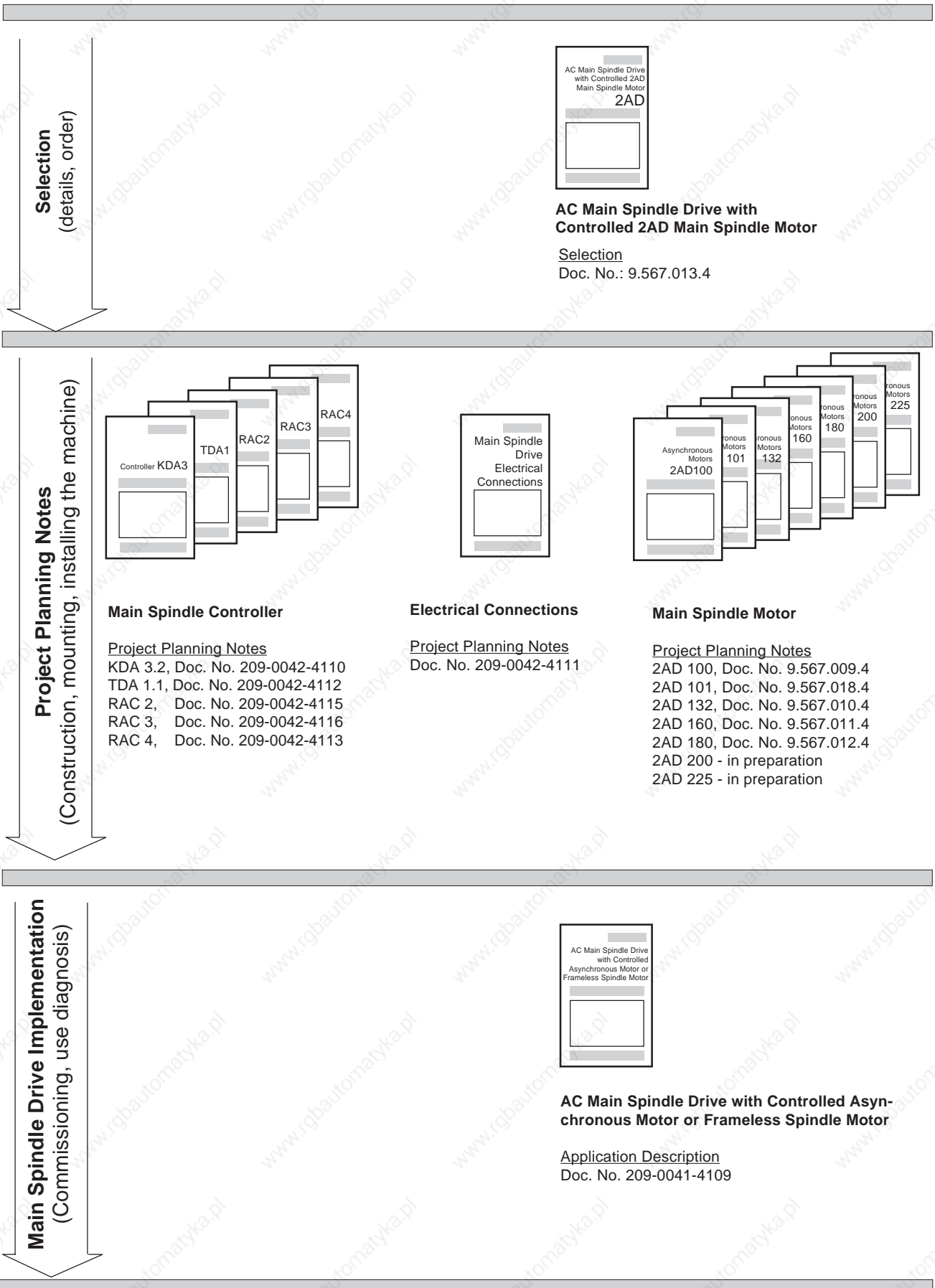
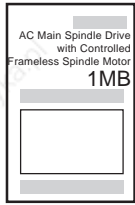
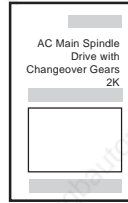

Figure 12.1: Summary of supplementary documentation



**AC Main Spindle Drive with Controlled Frameless Spindle Motor 1MB Selection**  
Doc. No. 9.567.012.4



**AC Main Spindle Drive with Controlled 2AD Asynchronous Motor and 2K Changeover Planetary Gearboxes Selection**  
Doc. No. 9.567.022.4

**Selection**  
(details, order)

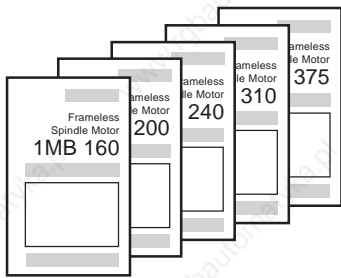

**Frameless Spindle Motor**

Project Planning Notes

1MB 160, Doc. No. 9.576.014.4  
1MB 200, Doc. No. 9.576.016.4  
1MB 240/241, Doc. No. 9.576.015.4  
1MB 310/312, Doc. No. 9.576.008.4  
1MB 375, Doc. No. 9.576.007.4

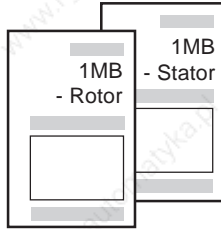

Mounting Guidelines

Stator, Doc. No. 9.600.063.4  
Rotor, Doc. No. 9.600.062.4

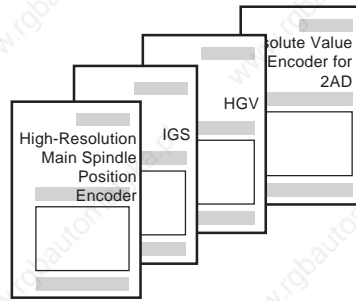

**Supplementary Documentation**

- High-resolution main spindle position encoder
  - Application description  
Doc. No. 9.552.247.4
  - Mounting guidelines  
Doc. No. 9.600.060.4
- Incremental encoder output IGS  
Doc. No. 9.568.015.4
- High-resolution encoder branching HGV  
Doc. No. 9.568.010.4
- Attachment absolute value encoder for 2AD 132, 2AD 160, 2AD 180  
Doc. No. 9.568.020.4

**Project Planning Notes**  
(Construction, mounting, installing the machine)

**Main Spindle Drive Implementation**  
(Commissioning, use diagnosis)

