

SIEMENS

SIMATIC

C7-621 / C7-621 AS-i Control Systems

Volume 1 Hardware and Installation

Manual

C79000-G7076-C621-01

Preface, Contents

User Information

Product Overview

1

Installation

Installing and Preparing
the C7

2

Configuring an MPI Network

3

Connecting a Programming
Device / PC to a C7

4

AS-i

Attaching a C7-621 AS-i

5

I/Os

C7-621 Digital I/Os

6

C7-621 Analog I/Os

7

Maintenance

8

Appendix

General Technical Specifica-
tions

A

Guidelines for Handling ESD
Devices

B

Safety of Electronic Controllers

C

SIMATIC C7 and S7 Refer-
ences

D

Glossary, Index

Safety Guidelines

This manual contains notices which you should observe to ensure your own personal safety, as well as to protect the product and connected equipment. These notices are highlighted in the manual by a warning triangle and are marked as follows according to the level of danger:



Danger

indicates that death, severe personal injury or substantial property damage will result if proper precautions are not taken.



Warning

indicates that death, severe personal injury or substantial property damage can result if proper precautions are not taken.



Caution

indicates that minor personal injury or property damage can result if proper precautions are not taken.

Note

draws your attention to particularly important information on the product, handling the product, or to a particular part of the documentation.

Qualified Personnel

The device/system may only be set up and operated in conjunction with this manual.

Only **qualified personnel** should be allowed to install and work on this equipment. Qualified persons are defined as persons who are authorized to commission, to ground, and to tag circuits, equipment, and systems in accordance with established safety practices and standards.

Correct Usage

Note the following:



Warning

This device and its components may only be used for the applications described in the catalog or the technical description, and only in connection with devices or components from other manufacturers which have been approved or recommended by Siemens.

This product can only function correctly and safely if it is transported, stored, set up, and installed correctly, and operated and maintained as recommended.

Trademarks

SIMATIC® and SMATIC NET® are registered trademarks of SIEMENS AG.

Third parties using for their own purposes any other names in this document which refer to trademarks might infringe upon the rights of the trademark owners.

Copyright © Siemens AG 1997 All rights reserved

The reproduction, transmission or use of this document or its contents is not permitted without express written authority. Offenders will be liable for damages. All rights, including rights created by patent grant or registration of a utility model or design, are reserved.

Siemens AG
Bereich Automatisierungstechnik
Industrial Automation Systems
Postfach 4848, D-90327 Nuernberg

Disclaimer of Liability

We have checked the contents of this manual for agreement with the hardware and software described. Since deviations cannot be precluded entirely, we cannot guarantee full agreement. However, the data in this manual are reviewed regularly and any necessary corrections included in subsequent editions. Suggestions for improvement are welcomed.

Subject to change without prior notice.
© Siemens AG 1997

Preface

Purpose

This manual will help you with the following tasks:

- Installing and wiring up a C7-621 or C7-621 AS-i (Volume 1)
- Assigning parameters to the CPU of the C7-621 or C7-621 AS-i, downloading a user program to the CPU, and starting up (Volume 2)
- Making the settings required on the C7-621 and C7-621 AS-i for operation and using the operator interface functions (Volume 2)

Audience

This manual is intended for two different groups of readers:

- Volume 1:
Users installing the C7 mechanically and electrically on site and preparing the C7 so that it is ready for operation.
- Volume 2:
Users creating control programs and operator interface configurations and downloading them to the C7.

Contents of the Manual

This manual describes the hardware and software of the C7-621 and C7-621 AS-i. It consists of two volumes.

Volume 1 of the manual deals with the following topics:

- Installing and preparing the C7-621 or C7-621 AS-i
- Networking the C7-621 or C7-621 AS-i with a programming device and other devices
- Connecting the digital and analog I/Os
- Connecting the IM 621 interface module

Volume 2 of the manual deals with the following topics:

- Startup of the C7
- Controlling with the C7 CPU
- Addressing and assigning parameters for the C7 I/Os
- C7 diagnostics
- AS-i system concept
- Using and operating AS-i
- Using the operator interface functions of the C7

Conventions for C7

To make the manual easier to read, the device types C7-621 or C7-621 AS-i will simply be called **C7** in the manual.

If the device is simply called **C7** in the manual, the information applies to both versions of the control system. Where differences occur, the full name of the unit will be used.

Scope of the Manual

This manual is valid for the following C7s:

C7	Order Number	Versions and Higher
C7-621	6ES7621-1AD00-0AE3	01
C7-621 AS-i	6ES7621-6BD00-0AE3	01

C7 Manual

This manual can be obtained under the order number 6ES7621-1AD00-8BA0.

Other Manuals Required

This manual describes the C7-621 and C7-621 AS-i. To program, expand and configure a C7, you also require the following manuals:

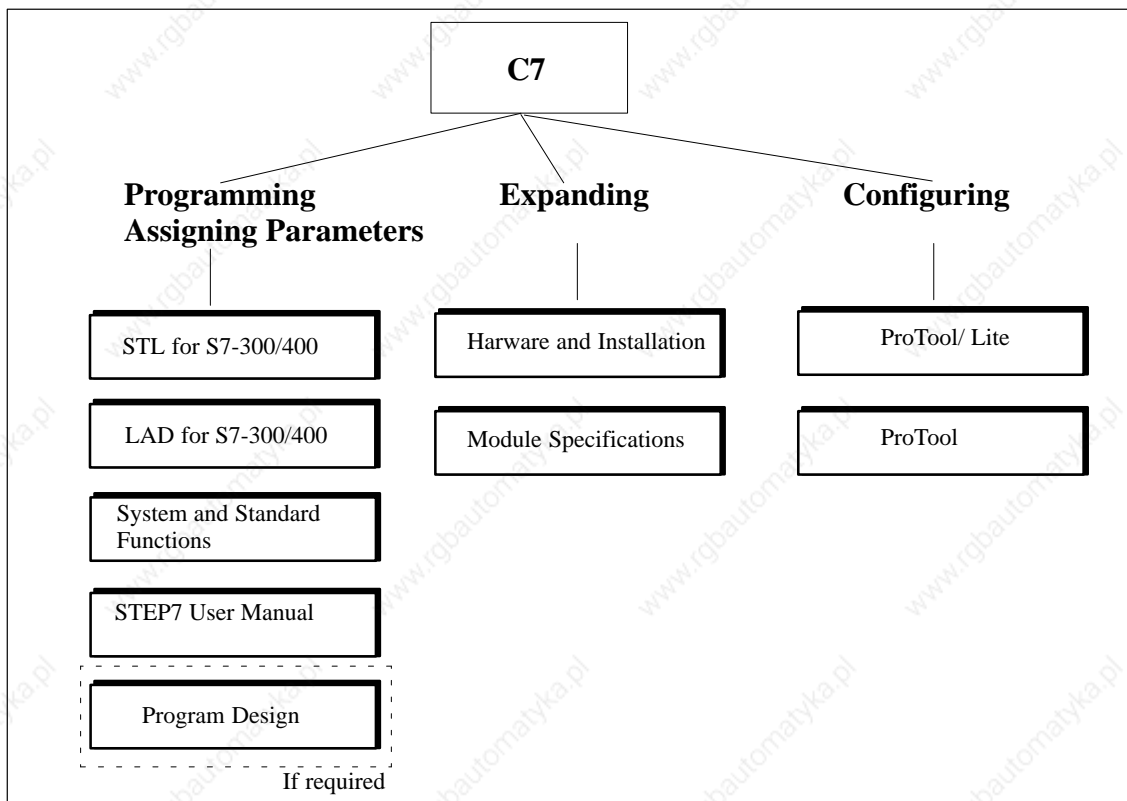

C7-621 AS-i Brochure

To familiarize yourself with the AS-i system, we recommend the following procedure:

- You should certainly read the AS-i brochure.

Actuator Sensor Interface

Order number E20001-P285-A497-V2-X-7600

This brochure can be ordered from all Siemens offices.

Table 1-1 STEP 7 Documentation Package, Order Number 6ES7810-4AA00-8AA0

Manual	Topics
<p><i>Standard Software for S7 and M7</i> <i>STEP 7 User Manual</i></p>	<p>This provides information about working with the STEP 7 tools.</p> <ul style="list-style-type: none"> • Installation and startup of STEP 7 on a PC/programming device • Using the tools: <ul style="list-style-type: none"> – Managing projects and files – Configuring the S7-300 and assigning parameters – Assigning symbolic names for user programs – Creating and debugging user programs in STL/LAD – Creating data blocks – Configuring communication between CPUs – Downloading, saving, and deleting user programs on CPUs and programming devices – Monitoring and modifying user programs (for example variables) – Monitoring and modifying the CPU (for example mode, memory reset, compress memory, protection levels)
<p>Manual: <i>STL for S7-300/400, Programming</i> or Manual: <i>LAD for S7-300/400, Programming</i></p>	<p>Reference manuals for programming with STL or LAD:</p> <ul style="list-style-type: none"> • Basics of working with STL/LAD (for example structure of STL/LAD, numerical formats, syntax) • Description of all instructions in STEP 7 (with program examples) • Description of the various ways of addressing in STEP 7 (with examples) • Description of all integrated functions on the CPUs • Description of the CPU-internal registers
<p>Reference Manual: <i>System Software for S7-300 and S7-400, System and Standard Functions</i></p>	<p>Detailed description of:</p> <ul style="list-style-type: none"> • All the standard functions (FCs) integrated in STEP 7 • All the system functions (SFCs) integrated in the operating system of the CPU
<p>User Manual: <i>Standard Software for S7, Converting S5 Programs</i></p>	<p>This manual provides information about converting STEP 5 programs to STEP 7:</p> <ul style="list-style-type: none"> • Working with the S5/S7 converter • Rules for conversion • Using converted STEP 5 standard function blocks in STEP 7
<p>Manual: General Index</p>	<p>General index of all the manuals in the documentation package.</p>

Further Information

Appendix D of Volume 2 of this manual contains a list with further sources of information about the S7-300 and programmable logic controllers.

Table 1-2 Further Manuals

Manual	Topics
Programming Manual: <i>System Software for S7-300 and S7-400, Program Design</i>	This manual contains basic information about designing STEP 7 programs: <ul style="list-style-type: none"> • Introduction to the efficient solution of programming tasks using a PC/programming device and STEP 7 • How the CPUs function (for example memory concept, access to inputs and outputs, addressing, blocks, data types, data management) • Description of STEP 7 data management • Using data types of STEP 7 • Using linear and structured programming (with program examples) • Using block call instructions • Overview of using STEP 7 tools for developing projects (with an extensive example) • Using test and diagnostic functions of the CPUs in user programs (for example error OBs, status word)
Manual: <i>S7-300 Programmable Controller, Hardware and Installation</i>	This manual describes the hardware of the S7-300: <ul style="list-style-type: none"> • Configuring the S7-300 • Installing the S7-300 • Wiring and preparing the S7-300 for startup • Properties and technical data of the S7-300 modules
Reference Manual: <i>Programmable Controllers S7-300, M7-300, Module Data</i>	This manual describes the hardware of the S7-300 modules: <ul style="list-style-type: none"> • Analog modules • Digital modules • Interface modules • Properties and technical data of the S7-300 modules
Instruction List: <i>S7-300 Programmable Controller, CPU 312/314/315/315-DP</i>	This describes the set of instructions of the CPU 312, CPU 314, CPU 315, and CPU 315-DP including the run times of all instructions.

Table 1-2 Further Manuals, continued

Manual	Topics
PG 7xx	Descriptions of the PG hardware: <ul style="list-style-type: none"> • Configuration and startup of the PG • Possible expansions • Configuration • Trouble shooting
SIMATIC HMI ProTool/ Lite	Manual for creating configurations: <ul style="list-style-type: none"> • Working with ProTool/Lite • Configuration • Displays and messages • Downloading a configuration to the C7
SIMATIC HMI ProTool	Manual for creating configurations: <ul style="list-style-type: none"> • Working with ProTool • Configuration • Displays and messages • Downloading configurations to the C7

Finding Your Way Round the Manual

To help you find specific information, the manual is laid out as follows:

- At the start of both volumes of the manual, you will find a complete table of contents.
- In the left margin of the chapters, there is a subtitle indicating the content of the section.
- After the appendix, there is a glossary listing important terminology used in the manual.
- At the end of the manual there is a detailed subject index.

Standards

The C7 control system complies with the standards described in Appendix A.1.

Questions

If you have questions about the C7 control system, please contact your Siemens representative.

There is a list with the addresses of Siemens representatives world-wide in Appendix E of Volume 2 of the manual.

If you have questions or comments about the manual itself, please complete and return the remarks form. You will find this at the end of Volume 2.

Contents

1	Product Overview	1-1
2	Installing and Preparing the C7	2-1
2.1	Components and Accessories of the C7	2-2
2.2	Installing a C7	2-3
2.3	Location of the C7	2-6
2.4	Electrical Installation and Pinouts	2-7
2.5	Guidelines for Trouble-Free Installation	2-13
2.6	Connecting Up Cables	2-15
2.7	Connector Key Inserts	2-16
2.8	Contrast	2-17
2.9	I/O Expansion with the IM 621	2-18
2.10	Memory Reset on the C7	2-20
2.11	Status and Error LEDs on the C7	2-23
2.12	Clocks on the C7	2-24
3	Configuring an MPI Network	3-1
3.1	Communication via the MPI Interface	3-2
3.2	Rules for Configuring an MPI Network	3-4
3.3	Cable Lengths	3-8
3.4	Network Components	3-10
3.5	Bus Connectors	3-12
3.5.1	PROFIBUS Bus Connector	3-13
3.5.2	Bus Connector 6ES7 972-0B.20-0XA0	3-14
3.5.3	Bus Connector 6ES7 972-0B.10-0XA0	3-17
3.5.4	Connecting the Bus Connector to a Module	3-19
4	Connecting a Programming Device / PC to a C7	4-1
4.1	Connecting a Programming Device / PC to a C7	4-2
4.2	Connecting a Programming Device/PC to Several Nodes	4-3
5	Attaching a C7-621 AS-i	5-1
5.1	AS-i Attachments	5-2
5.2	The AS-i Cable	5-3

6	C7-621 Digital I/Os	6-1
6.1	Digital Inputs	6-2
6.2	Digital Outputs	6-4
6.3	Status Displays of the DI/DO	6-7
7	C7-621 Analog I/Os	7-1
7.1	Connecting Sensors to Analog Inputs	7-2
7.1.1	Connecting Voltage and Current Sensors	7-5
7.2	Connecting Loads/Actuators to the Analog Output	7-7
7.3	Analog Input	7-10
7.3.1	Properties and Technical Data of the Analog Input Module	7-11
7.4	Analog Output	7-15
8	Maintenance	8-1
A	General Technical Specifications	A-1
A.1	Technical Specifications	A-2
A.2	Notes on the CE Approval	A-5
A.3	Notes for Manufacturers of Machines	A-7
B	Guidelines for Handling Electrostatically Sensitive Devices (ESD)	B-1
B.1	What is ESD?	B-2
B.2	Electrostatic Charging of Objects and Persons	B-3
B.3	General Protective Measures Against Electrostatic Discharge Damage ..	B-4
B.4	Taking Measurements and Working on ESD Modules	B-6
B.5	Packing Electrostatic Sensitive Devices	B-7
C	Safety of Electronic Controllers	C-1
D	SIMATIC C7 and S7 References	D-1
	Glossary	Glossary-1
	Index	Index-1

Product Overview

1

In This Chapter

This chapter introduces you to the C7-621 and C7-621 AS-i. A brief overview of the range of performance will give you a first impression of the two devices.

This chapter also explains the additional components that you can connect to a C7.

Accessories for Installing and Starting Up a C7

To install and start up the C7, you require the following accessories:

- Programming device or PC with an MPI interface and PG cable
- The following software must be loaded on the programming device or PC
 - STEP 7 Tools
 - ProTool or ProTool/Lite

Overview

There are two versions of the C7:

C7-621

With a two-line display and 20 characters per line with 5 mm high characters (see Figure 1-1).

The C7-621 has the following components:

- MPI interface
- Digital inputs and outputs
- Analog inputs and outputs
- P bus connection (for the IM 621 module)

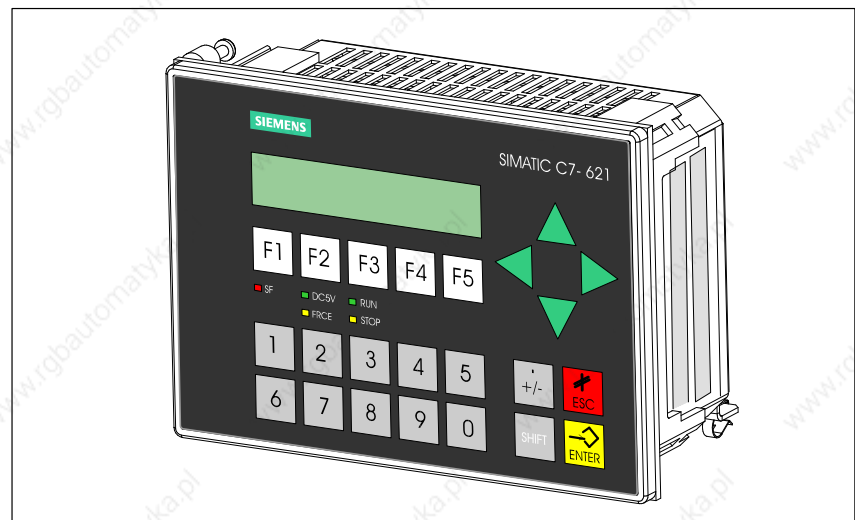

Figure 1-1 C7-621

Range of Functions

You can do the following with the C7-621:

- Run user programs that were written in STL, LAD or FBD and downloaded to the C7 CPU.
- Process digital and analog signals using the I/Os integrated on the C7.
- Download and use operator interface applications that you created with the “ProTool” or “ProTool/Lite” configuration tool.
- Using these configurations, you can monitor and intervene in the process you are controlling with the user program.
- Connect further S7-300 modules.

C7-621 Units

The C7 has two independent units that communicate with each other via an internal MPI interface:

- C7 CPU with digital and analog inputs and outputs
- C7 OP

Where necessary, these units are dealt with separately in the manuals.

C7-621 AS-i

With a two-line display and 20 characters per line with characters 5 mm high (see Figure 1-2).

The C7-621 AS-i has the following components:

- MPI interface
- AS-interface
- P bus connection (for the IM 621 module)

This model does not have digital inputs/outputs and analog inputs/outputs.

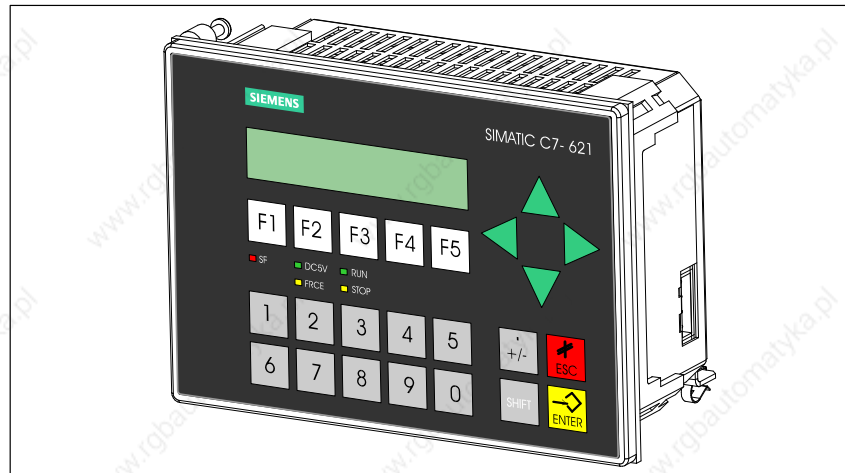

Figure 1-2 C7-621 AS-i

Range of Functions

You can do the following with the C7-621 AS-i control system:

- Run user programs that were written in STL, LAD or FBD and downloaded to the C7 CPU.
- Connect actuators and sensors via the AS-interface to the C7-621 AS-i.
- Download and use operator interface applications that you created with the “ProTool” or “ProTool/Lite” configuration tool.
- Using these configurations, you can monitor and intervene in the process you are controlling with the user program.
- Connect further S7-300 modules.

C7-621 AS-i Units

The C7 has two independent units that communicate with each other via an internal MPI interface.

- C7 CPU with C7 AS-i CP
- C7 OP

When necessary, these units are dealt with separately in the manuals.

Components that Can Be Connected to a C7

Apart from the connections to the process you can also connect various components to the C7. The most important components and their functions are listed in Table 1-1:

Table 1-1 Components that Can Be Connected to a C7





Component	Function	Schematic
IM 621 interface module with cable	...connects a C7 with an expansion rack for S7-300 modules	
Signal module (SM) (Digital input modules, digital output modules, analog input modules, analog output modules, analog input/output modules)	...adapt various process signal levels to the C7 CPU. Can be connected to the C7 via an IM 621.	
S7-300 (CPU)	...communicates via the MPI interface with C7 and with other nodes on an MPI network.	
S7-400 (CPU)	...communicates via the MPI interface with C7 and other nodes on an MPI network.	
OP (Operator Panel)	...allows operator interface functions.	
PROFIBUS LAN cable with bus connector	...interconnects nodes on an MPI network.	
PG cable	...connects a programming device/PC with a C7.	

Table 1-1 Components that Can Be Connected to a C7, continued

Component	Function	Schematic
Programming device (PG) or PC with the STEP 7 software package and ProTool or Pro Tool/Lite	...configures, assigns parameters, programs, and tests the C7.	
RS 485 repeater	...amplifies the signals in an MPI or PROFIBUS DP network and connects segments of an MPI or PROFIBUS DP network.	
Sensors and actuators		
AS-i slaves	Refer to the various catalogs (applies only to the C7-621 AS-i).	

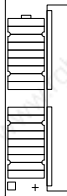
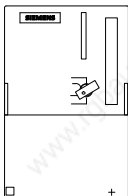
Overview of the C7

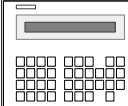
The SIMATIC C7-621/C7-621 AS-i devices consist of several components that interact with each other:

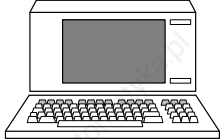
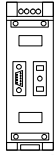
- A programmable controller CPU of the SIMATIC S7-300 class (C7 CPU),
- A line-oriented SIMATIC OP (C7 OP),
- Integrated digital and analog I/Os (C7-621 I/Os),
- A P bus connection for expanding the C7-621 with an IM 621 using S7-300 modules,
- An MPI interface for communication with the programming device/PC and other S7 CPUs, C7 control systems and OPs,
- An AS-interface (AS-i) for connecting sensors and actuators (version C7-621 AS-i, see Figure 1-4)

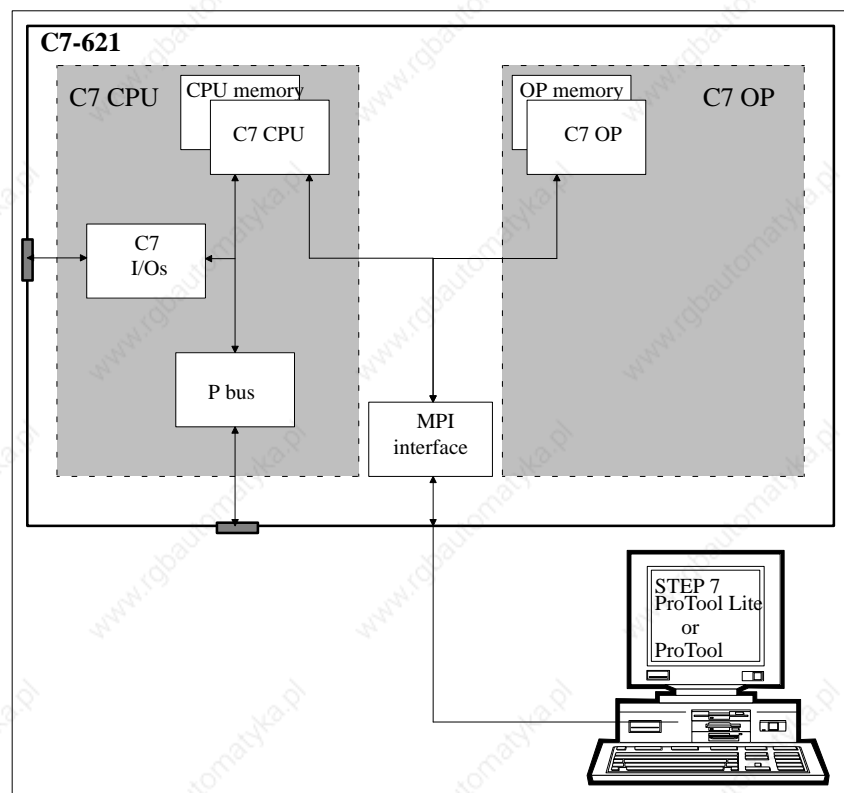

Figure 1-3 Components of the C7-621

The individual components integrated in the SIMATIC C7 correspond to the components that can also be used in the modular configuration consisting of an S7-300 CPU, OP etc. The I/O expansion via the P bus interface (IM 621) allows the connection of a maximum of four SIMATIC S7-300 modules. The AS-interface allows the connection of sensors and actuators to the C7-621 AS-i (Figure 1-4).

The basic functions also correspond to those of a modular configuration with standard modules from the programmable controller and OP families, the individual components operate independently of each other and each of the processors has its own memory.

C7 CPU is programmed with STEP 7 and the C7 OP is configured with ProTool/Lite.

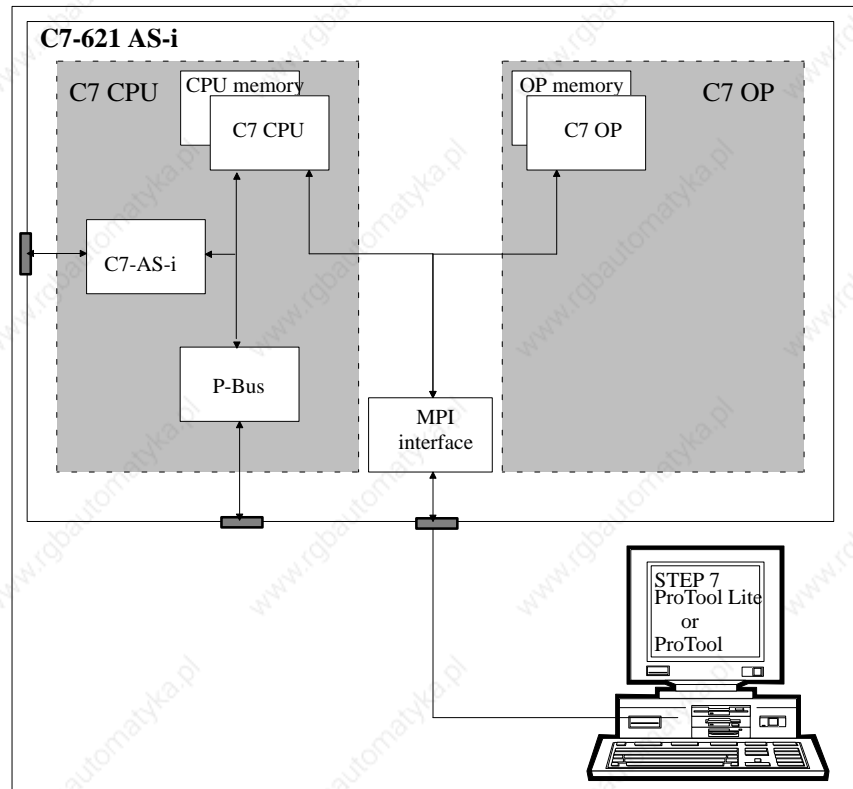

Figure 1-4 Components of the C7-621 AS-i

Installing and Preparing the C7

2

Chapter Overview

Section	Description	Page
2.1	Components and Accessories of the C7	2-2
2.2	Installing a C7	2-3
2.3	Location of the C7	2-6
2.4	Electrical Installation and Pinouts	2-7
2.5	Guidelines for Trouble-Free Installation	2-13
2.6	Connecting Up Cables	2-15
2.7	Connector Key Inserts	2-16
2.8	Contrast	2-17
2.9	I/O Expansion with the IM 621	2-18
2.10	Memory Reset on the C7	2-20
2.11	Status and Error LEDs on the C7	2-23
2.12	Clocks on the C7	2-24

2.1 Components and Accessories of the C7

Components Supplied with the C7-621

The following components are supplied with the C7-621:

- C7-621 (order number 6ES7 621-1AD00-0AE3)
- Grounding bar
- 6 shield clips
- Seal and 4 securing posts
- Set of connectors for C7 I/Os with key inserts
- Product information

Components of the C7-621 AS-i

The following components are supplied with the C7-621 AS-i:

- C7-621 AS-i (order number 6ES7 621-6BD00-0AE3)
- Seal and 4 securing posts
- Set of connectors for AS-i and C7 power supply with key inserts
- Product information

Accessories

The following components can be ordered as accessories for the C7:

- Manual: *C7-621, C7-621 AS-i Control Systems* consisting of two volumes in the following languages:
 - German: 6ES7 621-1AD00-8AA0
 - English: 6ES7 621-1AD00-8BA0
 - French: 6ES7 621-1AD00-8CA0
 - Italian: 6ES7 621-1AD00-8DA0
 - Spanish: 6ES7 621-1AD00-8EA0
- Service package (seal and 4 securing posts) 6ES7 623-1AE00-3AA0
- Set of connectors for C7 I/Os with key inserts 6ES7 623-1AE00-4AA0
- IM 621 interface module with cable 6ES7 621-1AD00-6AE3

2.2 Installing a C7

The Installation

The C7 is designed for fixed installation in a switching panel or wiring closet door. To install the C7, follow the steps outlined below:

Step	Action
1.	Cut out a section of the switching panel as shown in Figure 2-2.
2.	Insert the sealing ring behind the front panel (see Figure 2-1).
3.	Insert the C7 into the cutout in the switching panel.
4.	Insert the 4 securing posts (see Figure 2-3) into the guides, pushing them until the spring engages.
5.	Screw the 4 securing screws supplied with the C7 into the 4 securing posts (see Figure 2-4 ①).
6.	Tighten the 4 screws with a screwdriver (tightening torque 0.6 Nm).

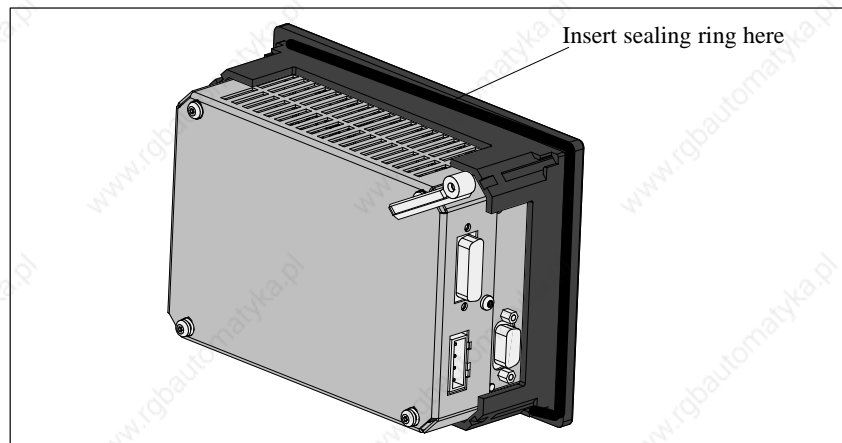

Figure 2-1 Inserting the Sealing Ring

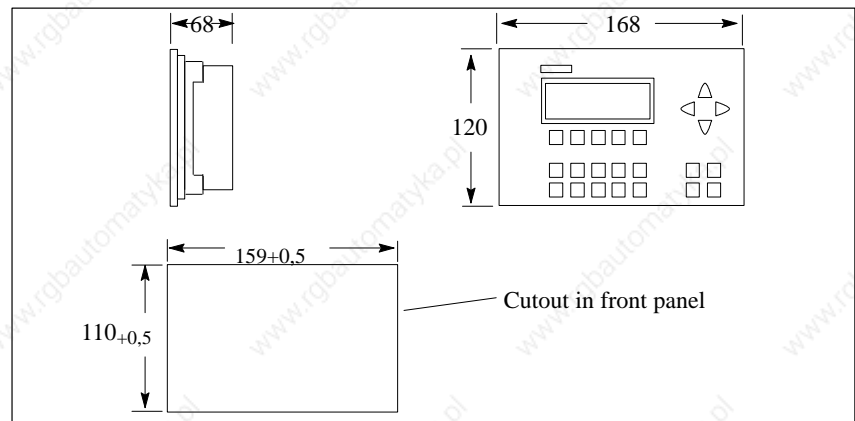

Figure 2-2 Dimension Drawings for the C7

Securing Post Before Engaging

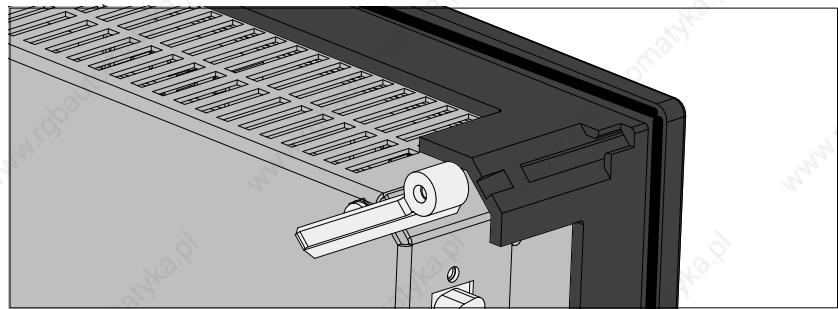

Figure 2-3 Securing Post Before Engaging

Securing Post Engaged

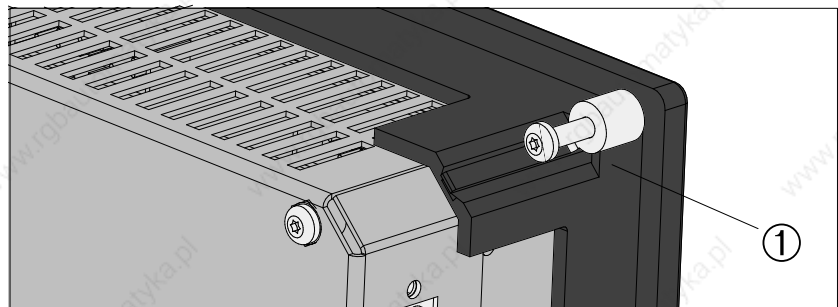

Figure 2-4 Securing Post Engaged, with Screw

Releasing the Securing Post

To release a securing post, follow the steps outlined below:

Step	Action
1.	Loosen the screw.
2.	Lever the securing post upwards (① in Figure 2-5).
3.	Lever the securing post out of the guide (② in Figure 2-5).

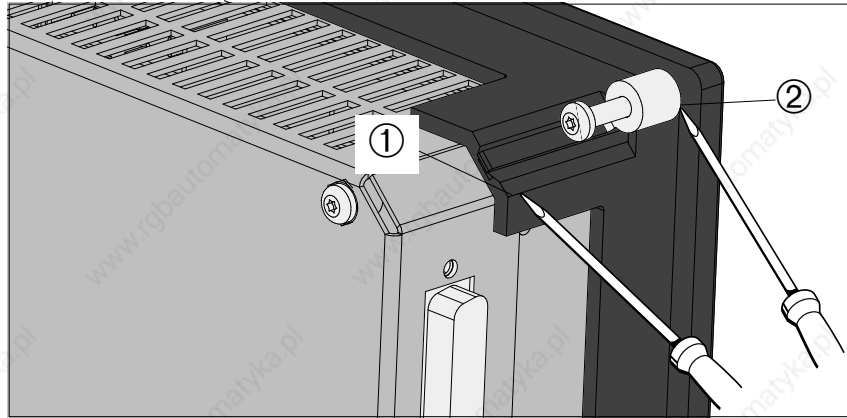

Figure 2-5 Removing the Securing Post

2.3 Location of the C7

Points to Note When Installing the C7

When installing the C7, please remember the following points:

- The thickness of the switching panel can be between 1 and 4 mm. Make sure that the sealing ring makes a tight seal all round.
- There must be a clearance of at least 50 mm above and below and 70 mm at the sides of the C7 as shown in Figure 2-6.
- Make sure that the sealing ring on the front panel sits correctly.
- Choose a location for the C7 away from direct sunlight.

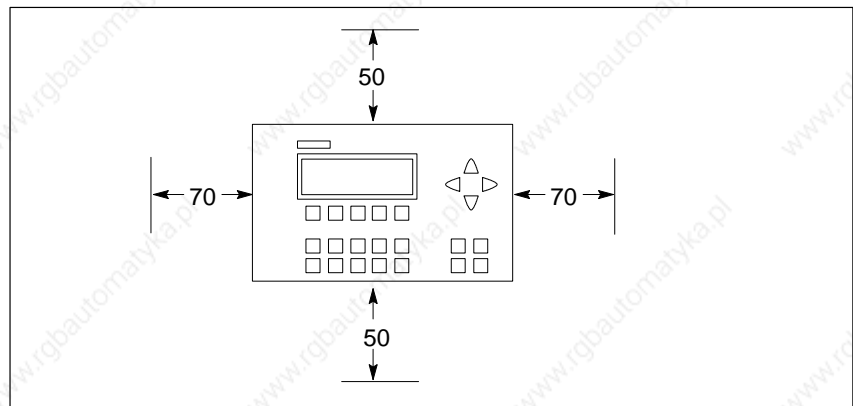

Figure 2-6 Minimum Clearances when Installing the C7

2.4 Electrical Installation and Pinouts

Overview To allow various components to be connected, the C7 is equipped with male and female connectors.

C7-621 and C7-621 AS-i Figure 2-7 illustrates the connection of the C7 power supply for a C7-621. The pinouts of the connectors are shown in the following tables.

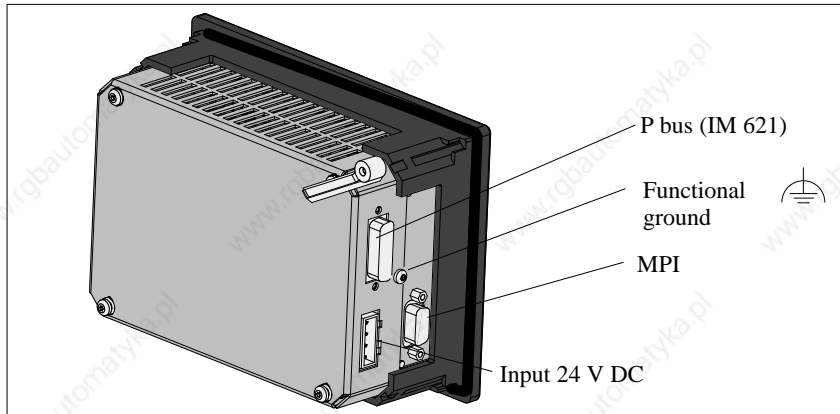



Figure 2-7 Power Supply Connectors for the C7-621

Input 24V DC The pinout of the input 24V DC (C7 power supply) and DI/DO power supply is shown below. The C7 CPU, C7 OP and digital/analog sections (C7-621) are supplied with power.

Table 2-1 Pinout

Pin	Function
L+	DC 24V
M	(chassis M24V)
NC	not connected
NC	not connected

MPI Connector for MPI-compliant components.

Functional Ground Connect functional ground  (see Figure 2-7) to the closest available point of the closet chassis using a cable lug and a cable with a minimum cross-sectional area of 4 mm².

P Bus (IM 621) To connect an S7-300 expansion rack via an IM 621.

C7-621

Figure 2-8 illustrates the C7-621 with digital and analog connectors. These connectors only exist on the C7-621. The pinouts of the connectors are shown in the following tables.

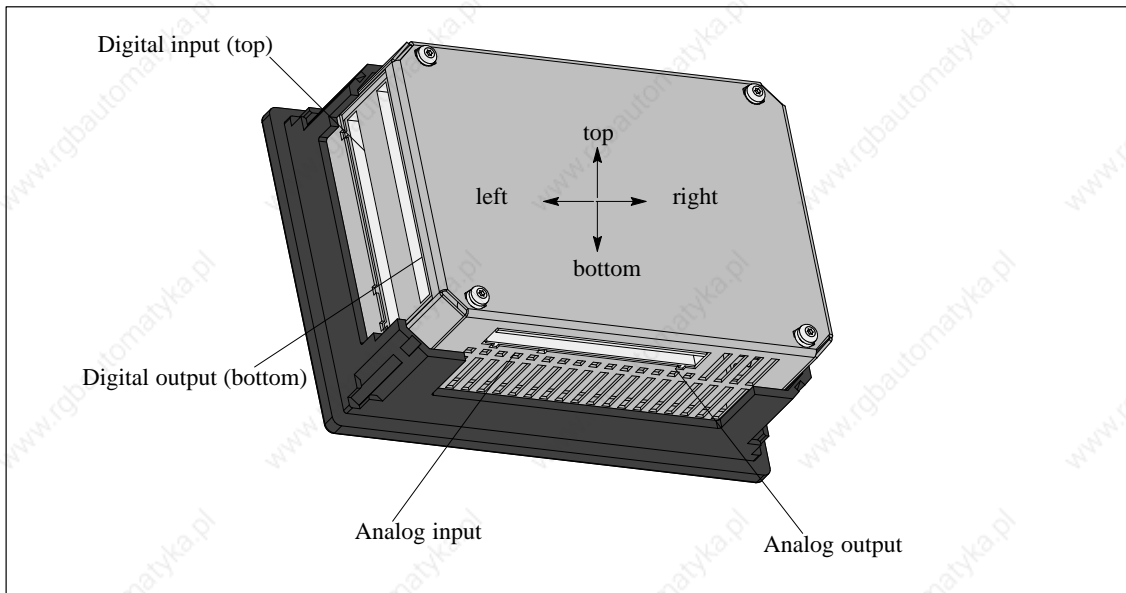

Figure 2-8 View of a C7-621 with External I/O Ports

Digital Input

Table 2-2 Pinout of the Digital Inputs

Pin	Signal	Function
0.0	I124.0	Digital input 0
0.1	I124.1	Digital input 1
0.2	I124.2	Digital input 2
0.3	I124.3	Digital input 3
0.4	I124.4	Digital input 4
0.5	I124.5	Digital input 5
0.6	I124.6	Digital input 6
0.7	I124.7	Digital input 7
1.0	I125.0	Digital input 8
1.1	I125.1	Digital input 9
1.2	I125.2	Digital input 10
1.3	I125.3	Digital input 11
1.4	I125.4	Digital input 12
1.5	I125.5	Digital input 13

Table 2-2 Pinout of the Digital Inputs, continued

Pin	Signal	Function
1.6	I125.6	Digital input 14
1.7	I125.7	Digital input 15

Digital Output

Table 2-3 Pinout of the Digital Outputs

Pin	Signal	Function
0.0	Q124.0	Digital output 0
0.1	Q124.1	Digital output 1
0.2	Q124.2	Digital output 2
0.3	Q124.3	Digital output 3
0.4	Q124.4	Digital output 4
0.5	Q124.5	Digital output 5
0.6	Q124.6	Digital output 6
0.7	Q124.7	Digital output 7
1.0	Q125.0	Digital output 8
1.1	Q125.1	Digital output 9
1.2	Q125.2	Digital output 10
1.3	Q125.3	Digital output 11
1.4	Q125.4	Digital output 12
1.5	Q125.5	Digital output 13
1.6	Q125.6	Digital output 14
1.7	Q125.7	Digital output 15

Analog Input/ Output

Table 2-4 Pinout of the Analog Inputs/Outputs

Pin	Function
AI1-U	Analog input 1, signal input for voltage
AI1-I	Analog input 1, signal input for current
AI1-M	Analog input 1, reference potential
AI2-U	Analog input 2, signal input for voltage
AI2-I	Analog input 2, signal input for current
AI2-M	Analog input 2, reference potential
AI3-U	Analog input 3, signal input for voltage
AI3-I	Analog input 3, signal input for current
AI3-M	Analog input 3, reference potential
AI4-U	Analog input 4, signal input for voltage
AI4-I	Analog input 4, signal input for current
AI4-M	Analog input 4, reference potential
AO-U	Analog output, signal output für voltage
AO-I	Analog output, signal output für current
AO-M	Analog output, reference potential

P Bus (IM 621)

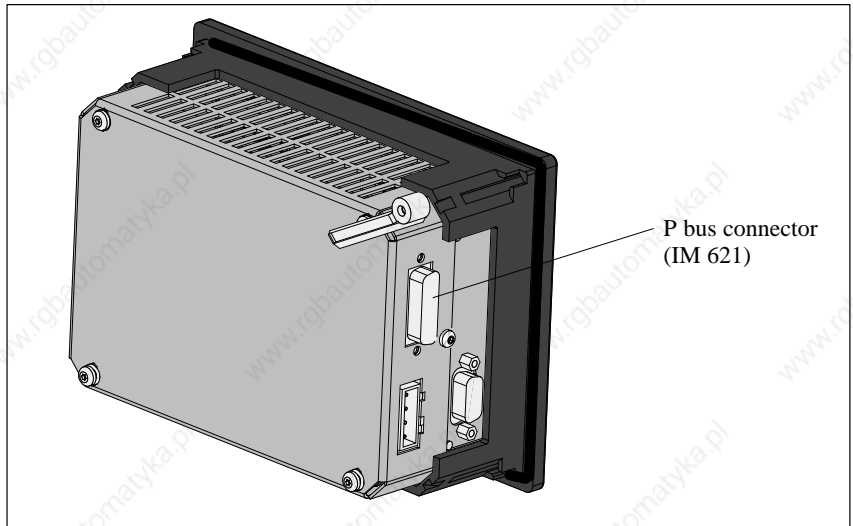

Figure 2-9 C7-621 with IM 621 Connector

C7-621 AS-i

The figure illustrates the AS-i connector of the C7-621 AS-i. This connector only exists on the C7-621 AS-i.

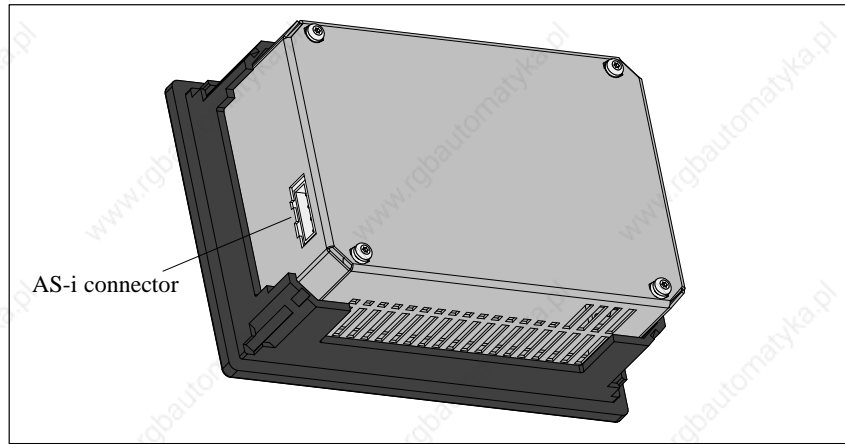

Figure 2-10 C7-621 AS-i with AS-i Connector

AS-i Connector

To connect actuators, sensors and the AS-i power supply unit

Table 2-5 Pinout of the AS-Interface

Pin	Function
AS-i -	Connected internally with AS-i -
AS-i +	Connected internally with AS-i +
AS-i -	Connected internally with AS-i -
AS-i +	Connected internally with AS-i +

Device Connectors of the C7

You can use the following connecting cables to connect the C7 to other components:

Table 2-6 Connecting Cables for the C7 Connectors

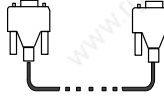
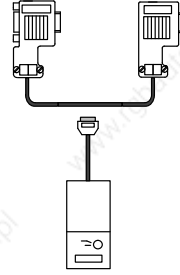
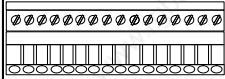
Connecting Cable	Comments	Schematic	Connection Between ...
MPI Interface			
PG cable	-		C7 ↔ PG C7 ↔ S7-300 C7 ↔ S7-400 C7 ↔ OP
PROFIBUS LAN cable, Interior cable, Underground cable and bus connector, without PG interface, with PG interface and PROFIBUS bus terminal RS 485, with 1.5 m, and 3 m cable, with PG interface and 1.5 m cable.	The cable must be assembled by the user		C7 ↔ PG C7 ↔ C7 C7 ↔ S7-300 C7 ↔ S7-400 C7 ↔ OP
Connectors for C7 I/Os			
Connector for C7 I/Os Conductor cross-section	16 pin 4 pin 0.2 to 2.5 mm ²		C7 ↔ external sensor

2.5 Guidelines for Trouble-Free Installation

Overview

To prevent disturbances, the wiring and cabling in an automation system must be installed according to certain rules.

If a system is poorly grounded or not shielded, low frequency and high frequency interference signals can be coupled into the internal bus of the controller and cause malfunctions.

Interference signals or noise can be caused for example by switching relays or contactors (rapid changes in current or voltage levels, high frequency interference signals) or by different ground potentials between two sections of the system (low frequency interference signals).

Cabling Rules

Only shielded cables are permitted for data lines and analog signal lines.

- Cable shields must be grounded at both ends.

The standard cables in the catalogs *ST80.1* and *ST70* meet these requirements.

- All plug-in connectors must be secured by screws or locked in position.
- Data lines and signal lines must not be laid parallel to power lines. Use a separate cable duct for signal lines with a minimum clearance of 50 cm to power lines.

Wiring Closet Layout

Install devices that could introduce interference signals from the outside at the bottom of the wiring closet. The grounding rail should be located directly at the point of entry to the closet so that cables that could be carrying interference signals can be connected directly to ground. The shields of all shielded cables must make contact here. If the signal lines have a double shield, only the outer shield makes contact here.

Install long signal lines along the walls of the wiring closet. To reduce interference, it is important to plan the layout of the wiring closet in keeping with the EMC guidelines. All the chassis connections in the wiring closet must be established with large conductor cross-sections and contact should be over a large an area as possible.

Analog devices installed in the wiring closet should be insulated and grounded at one point in the closet (use copper band!).

Always use metal parts with the same electrical characteristics in the cabinet (do not use aluminum due to the danger of oxidization).

All the doors and metal panels (side, rear and top panels) of the wiring closet should be connected at least three times to the closet frame (keep the connections short and make sure that contact is over a large area with bare, unpainted metal).

Note

If you use equipment that generates high electrostatic voltages (for example textile machinery), the grounding cables of the machine parts producing high voltage interference signals should be connected to a separate ground (surface grounding with building construction, reinforcement) from the grounding point of the wiring closet.

The manual */70/* contains installation guidelines and deals with measures for protecting from interference.

Overvoltage Protection

Measures to prevent overvoltage and lightning protection are described in the guidelines in */70/* .

2.6 Connecting Up Cables

Overview

This chapter describes how to connect the shield of shielded signal cables with ground. The shield is connected directly to the ground terminal of the C7 via a grounding bar.

Procedure

Fit the grounding bar and the shield clips supplied with the C7-621 as follows:

1. Remove the two screws from the C7-621 as shown in Figure 2-11.
2. Position the grounding bar as shown in Figure 2-11 and fasten it in position with the two screws previously removed.
3. Fit the shield clips on to the grounding bar as shown in Figure 2-11.
4. Press the stripped cable into the shield clips so that the shield of the cable makes the best possible contact.

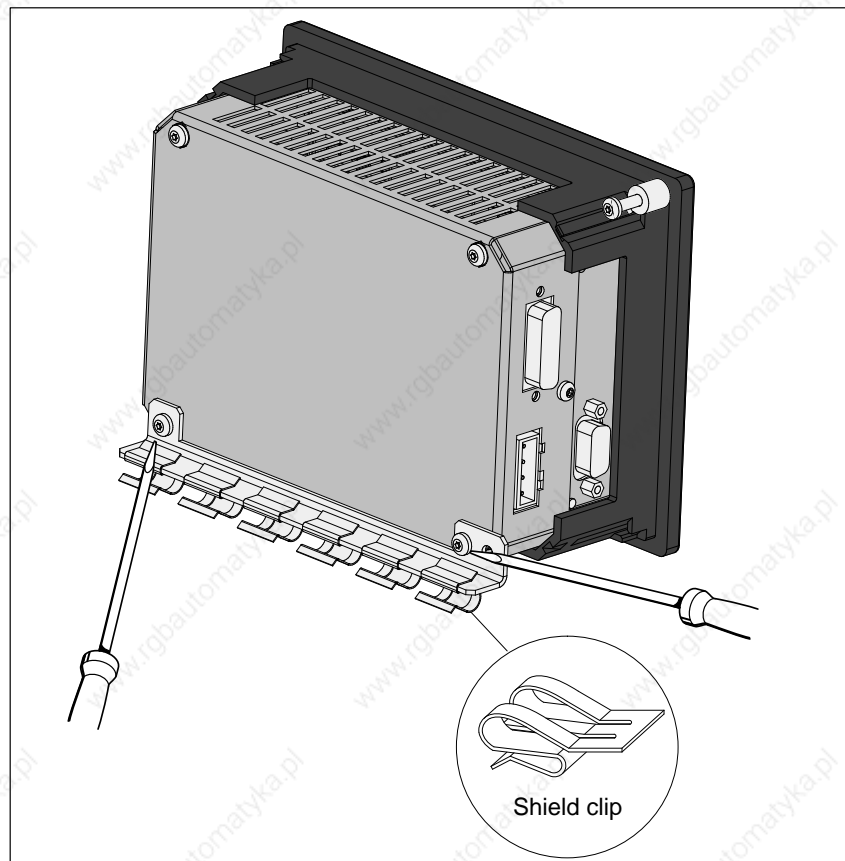

Figure 2-11 C7-621 with Grounding Bar and Shield Clips

2.7 Connector Key Inserts

Overview

You can order a set of connectors with key inserts for a C7 (see Section 2.1, Accessories). How you key or code the connectors is explained below:

Keying Connectors

With the solid keys ① and the profile keys ② (see Figure 2-12) you can configure a connector so that it cannot be inserted in the wrong receptacle without having to sacrifice a pin.

Follow the steps below:

1. Insert solid keys ① into the grooves on the connector ❶ .
2. Insert the profile keys ② into the cutouts on the housing ❷ .

Where solid and profile keys face each other, the connector cannot be inserted.

If the solid and profile keys do not face each other, the connector can be inserted.

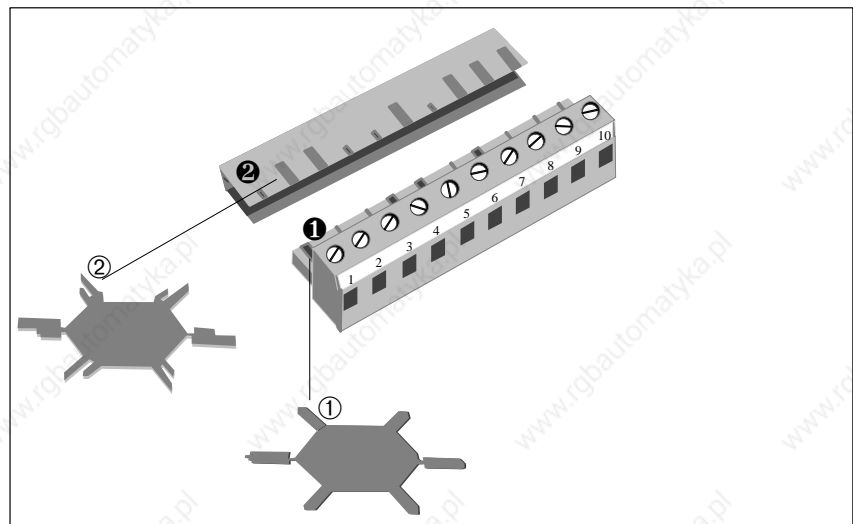

Figure 2-12 Preventing Insertion of the Wrong Connector



Warning

Keying connectors is strongly advised to prevent damage to the C7-621.

2.8 Contrast

Setting the Contrast

You can set the contrast of the C7 display using the screw as shown in Figure 2-13 and adapt the contrast to the lighting conditions.

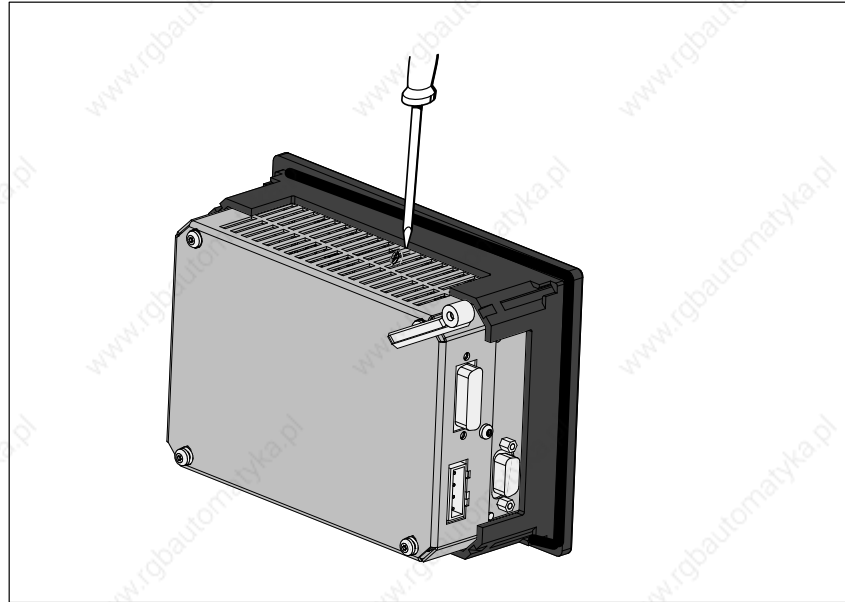

Figure 2-13 Setting the Contrast

2.9 I/O Expansion with the IM 621

Additional S7-300 Modules

You can connect further S7-300 I/Os to the C7 via the P bus connector of the C7-621 or C7-621 AS-i.

How you install the S7 modules, is described in the manual /71/.

Note

You can connect a maximum of four I/O modules to the C7.

Requirements

The S7-300 system must have an IM 621 interface module.

Connecting the Additional I/Os

Connect the additional I/Os as following:

1. Install the additional I/O modules as described for the rack in the manual /70/.
2. Connect the C7-621 or C7-621 AS-i to the IM 621 interface module via an IM 621 standard cable (for the connection to C7, see also Figure 2-9). An IM 621 cable is supplied with the module and is connected to the IM 621 interface module.

The first time you start up the C7, it detects the connected additional modules.

Addresses

Addressing on the C7 is described in Volume 2 Chapter 4.

P Bus Interface

The C7 has an integrated P bus interface for I/O expansions with external S7-300 standard I/Os.

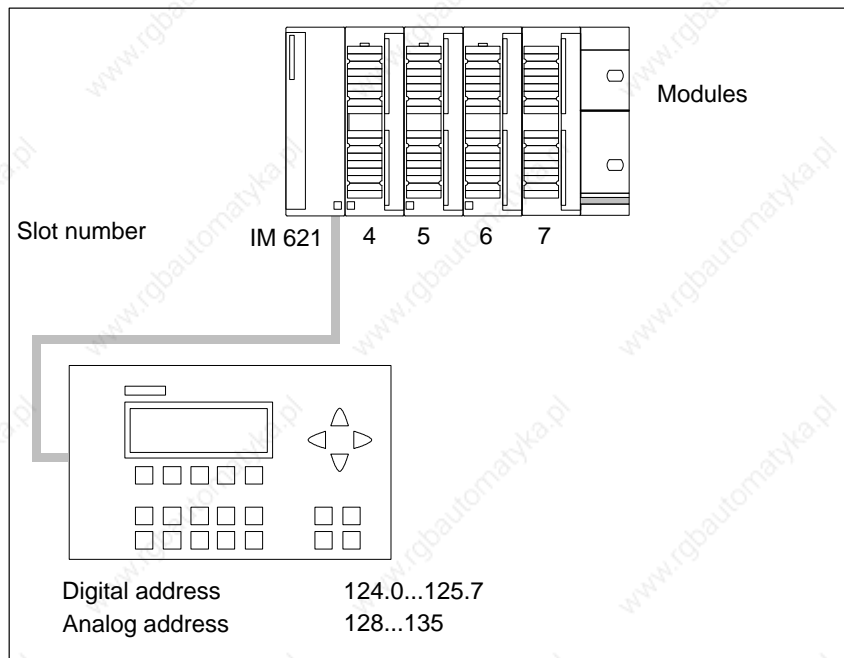

Figure 2-14 Maximum Configuration with a C7-621

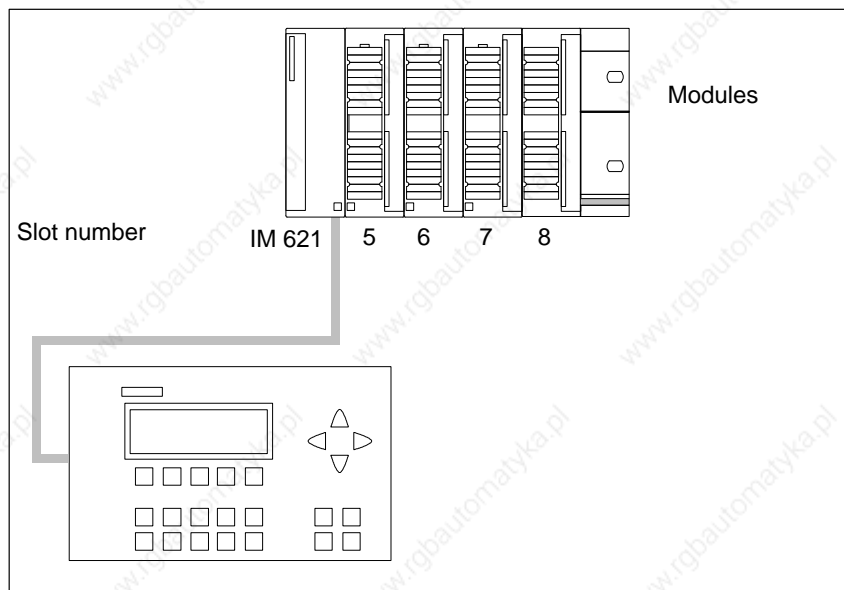

Figure 2-15 Maximum Configuration for a C7-621 AS-i

2.10 Memory Reset on the C7

Memory Reset on the C7 OP

The C7 must be turned off. To reset the memory of the C7 OP, follow the steps outlined below:

1. Press and hold down the following keys at the same time:



2. Turn on the power to the C7.
3. Wait until a line appears under the text FLASHTEST.
4. The C7 OP then starts up with English texts.
5. Following this the memory of the C7 OP is reset, in other words the C7 OP is reinitialized and the **entire configuration is deleted**.

Note

The default configuration contained in the firmware in English remains available and can be worked with.

Memory Reset on the C7 CPU

A memory reset on the C7 CPU means that the C7 CPU is reinitialized, the current user program in the RAM is deleted and any user program currently in the flash memory of the C7 CPU is reloaded.



There are two ways of resetting the C7 CPU memory:

- Memory reset using the C7 system function “C7 CPU Mode” on the C7
- Memory reset using the PG function (see programming device manual)

A memory reset using the PG function is only possible with the C7 CPU in the STOP mode.

Memory Reset on the C7 CPU Using the System Function

The section below describes how to reset the C7 CPU memory with the **C7 CPU Mode** system function:

1. Select the system functions menu by pressing the keys  

The following is displayed on the C7-621:

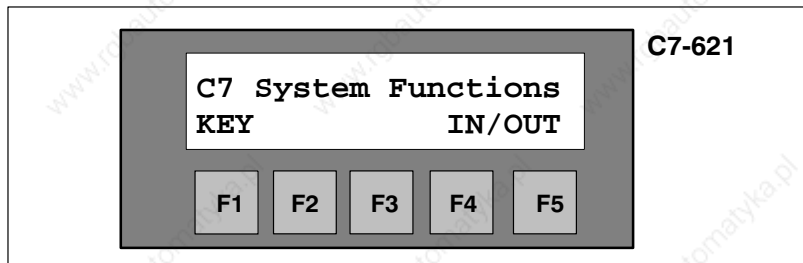

Figure 2-16 C7-621 System Functions Menu with Function Keys

or for the C7-621 AS-i

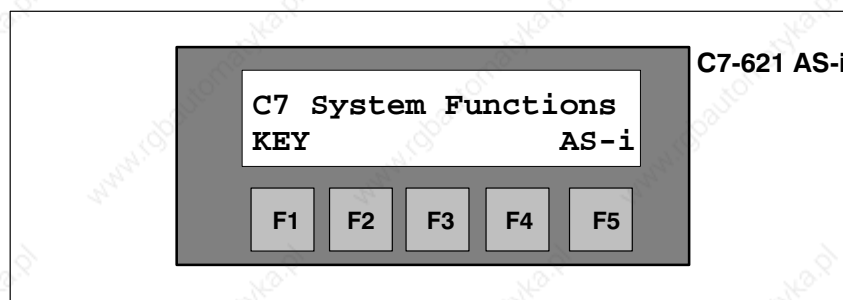

Figure 2-17 C7-621 AS-i System Functions Menu with Function Keys

2. Select the **C7 CPU Mode** menu by pressing 

If you have not yet entered a password, this will be requested.

3. Enter the password (this is explained in Volume 2 Section 7.6).

The following menu is displayed.

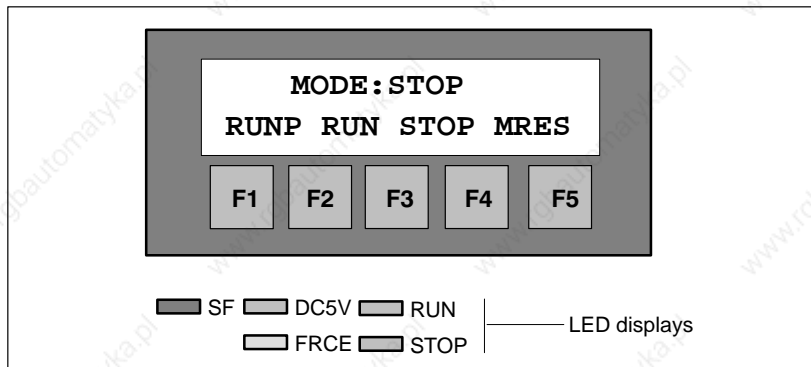

Figure 2-18 “C7 CPU Modes” Menu with Function Keys

4. Select the STOP function by pressing **F3**.
The STOP LED lights up.
 5. Select the MRES (Memory Reset) function by pressing **F4** and wait until the STOP LED goes off twice.
 6. Immediately after the STOP LED lights up again:
Select STOP and immediately afterwards MRES (within 1 second). If there is more than 1 second between pressing the two keys, the memory reset is not performed.
- Result:**
- When the STOP LED flashes quickly for approximately 3 seconds and is then lit continuously again, the memory on the C7 CPU has been reset.
 - If the STOP LED of the C7 lights up without first flashing, then repeat Steps 4 and 5.
7. Following the memory reset, you must set the C7 CPU explicitly to STOP or RUN/RUNP otherwise the C7 CPU is still set to MRES.

Note

A memory reset does not affect the content of the C7 CPU flash memory.

How to delete the content of the flash memory is described in Volume 2, Section 3.8.

2.11 Status and Error LEDs on the C7

Status and Error LEDs

The C7-621 or C7-621 AS-i has the following status and error LEDs:

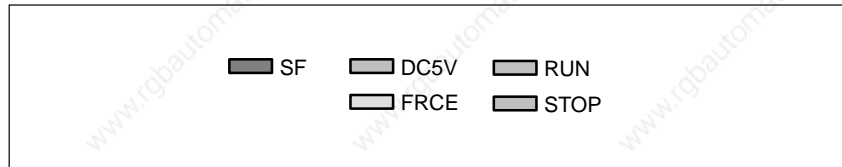

Figure 2-19 Status and Error LEDs of the C7-621 or C7-621 AS-i

Meaning of the Status and Error LEDs

The status and error LEDs are explained in the order in which they appear on the C7.

LED	Meaning	Explanation
SF (red)	C7 CPU group error	<p>Lights up in the following situations:</p> <ul style="list-style-type: none"> • Hardware faults • Firmware errors • Programming errors • Parameter assignment errors • Math errors • Time errors • Defective internal memory • I/O fault/error in the internal I/O functions <p>To find out the exact cause of the problem read out the diagnostic buffer using a programming device..</p>
DC5V (green)	5V DC power supply for the C7	Lights up when the internal 5V DC power supply is functioning correctly.
FRCE (yellow)	Reserved	-
RUN (green)	RUN or RUNP mode on the C7 CPU	<p>Lights up when the C7 is executing the user program.</p> <p>Flashes (several times) during the C7 startup. After the STOP LED goes off, the outputs are enabled.</p>
STOP (yellow)	STOP mode on the C7 CPU	<p>Lights up when the C7 is not executing the user program.</p> <p>Flashes at 1 second intervals when a memory reset has been requested by the operator or by the C7 CPU.</p> <p>Flashes twice; refer to installation.</p>

2.12 Clocks on the C7

Overview

The C7 devices have two software clocks:

- One clock on the C7 CPU
- One clock in the C7 OP

Clock on the C7 CPU

The clock of the C7 CPU is a software clock. This clock is independent of the clock of the C7 OP.

Default C7 CPU Time

When the unit is shipped, the following value is set:
DT#1994-0-01-00:00:00.

Master Clock

As an integrated clock, the C7 CPU clock can also function as the master clock within the C7 I/O configuration.

Setting and Reading Out the C7 CPU Clock

You set and read the time as follows:

- With a programming device using STEP 7
or
- In the STEP 7 user program using SFC 0 "SET_CLK". With SFC 1 "READ_CLK" you can read out the current time (refer to the reference manual /235/).

Clock Reaction to Power Off

If the power is turned off, the current time is saved in the non-volatile memory. When power is turned on again, the clock continues to run starting from the saved time.

When the power is turned off, the C7 CPU clock itself stops.

Clock on the C7 OP

The clock on the C7 OP is independent of the clock on the C7 CPU. When the power is turned off, the C7 OP clock stops.

Default OP Time

When the device is shipped, the clock is set to the following value:
01.01.94 -00:00.

Setting and Reading Out the C7 OP Clock

You set the time as follows:

- Using a job in the user program and interface block.
or
- Online by selecting the special display "Time/Date" if this was configured.

Run-Time Meter

The C7 CPU is equipped with a run-time meter.

This allows you to count the operating hours of the C7 CPU or a resource it controls.

You program the run-time meter in the user program using the SFCs 2 “SET_RTM”, 3 “CTRL_RTM” and 4 “READ_RTM” (see reference manual /235/).

Configuring an MPI Network

In this Chapter

This chapter describes how to configure an MPI network. You will learn the following:

- Which communication options are available to you with an MPI network.
- The components to which you can connect the nodes of an MPI network.
- The maximum and minimum cable lengths you can use.
- How to connect the PROFIBUS LAN cable to the bus connector.
- How to use an RS 485 repeater.
- Special considerations when connecting a programming device.

Before the individual nodes on an MPI network can communicate with each other, you must assign MPI addresses to them. How you assign MPI addresses and the rules to be observed are described in the user manual /231/ for S7 and in the *ProTool* documentation for the C7 OP.

Volume 2 of this manual, Section 3.4.10 contains the information you require for configuring communication with specific C7 CPUs.

Chapter Overview

Section	Description	Page
3.1	Communication via the MPI Interface	3-2
3.2	Rules for Configuring an MPI Network	3-4
3.3	Cable Lengths	3-8
3.4	Network Components	3-10
3.5	Bus Connectors	3-12
3.5.1	PROFIBUS Bus Connector	3-13
3.5.2	Bus Connector 6ES7 972-0B.20-0XA0	3-14
3.5.3	Bus Connector 6ES7 972-0B.10-0XA0	3-17
3.5.4	Plugging the Bus Connector into a Module	3-19

3.1 Communication via the MPI Interface

**Definition:
Multipoint
Interface MPI** The C7 interface for connecting devices such as programming devices is known as the Multipoint Interface since several devices at different locations (points) can communicate with the C7 via this interface.

Transmission Rate The transmission rate of the C7 is fixed at 187.5 Kbps.

**Connectable
Devices** You can create an MPI network by interconnecting the following devices:

- Programming devices (PG/PC)
- Operator interface systems (OPs)
- S7-300 / M7-300
- S7-400 / M7-400
- Further C7s
- FMs, CPs

Device/Node Convention: In the following sections, all the devices interconnected on an MPI network will be called nodes. Please note that the C7 itself occupies two MPI addresses and therefore represents two nodes, as follows:

- One for the C7 CPU
- One for the C7 OP

Segment A segment is a section of the network between two terminating resistors. A segment can include up to 32 nodes. A segment is also limited by the maximum permitted cable length that depends on the transmission rate (see Section 3.3)

Number of Nodes You can interconnect up to 126 (addressable) nodes on an MPI network.

MPI Addresses To allow all the nodes connected to the MPI network to communicate with each other, you must assign an MPI address to each node and you must also set a highest MPI address. Before you network the nodes, you must assign the MPI addresses individually on a programming device.

Note

The RS 485 repeater is not assigned an MPI address.

Default MPI Addresses of the C7

The following table shows the default MPI addresses set on the devices when they are shipped.

Node (Device)	Default MPI Address	Default Highest MPI Address
PG	0	15
C7 OP	1	Depends on the OP
C7 CPU	2	15

Rules for MPI Addresses

When assigning MPI addresses, keep to the following rules:

- Each MPI address within an MPI network must be unique.
- The highest possible MPI address must be higher than the highest actual MPI address and must be set to the same value on all nodes. (Exception: connecting a programming device to several nodes; see Chapter 4).

CPU-CPU Communication

A CPU can communicate with up to four C7 CPUs or S7-300 CPUs. These can exchange shared data with each other. For more detailed information about shared data, refer to the manual /231/.

GD Circles

The transmission and reception of shared data is organized in GD circles. Each C7 CPU can be included in up to four different GD circles.

3.2 Rules for Configuring an MPI Network

Overview

This section deals with the following topics:

- How to configure an MPI network
- Rules for configuring the network

Rules

Remember the following rules when connecting nodes to an MPI network:

- **Before** interconnecting the individual nodes of the MPI network, you must first assign the MPI address and the highest MPI address to each node (except for the RS 485 repeater).

Tip: Put a label with the MPI address on the housing of all the nodes in the MPI network. This means that you can always see which MPI address has been assigned to which node in your system.

- Connect up all the nodes on the MPI network as shown in Figure 3-3, in other words integrate the stationary programming devices and OPs directly in the MPI network.

This means that only the programming devices or OPs required for installation or maintenance must be connected via tap lines to the MPI network.

- If you operate more than 32 nodes in a network, the bus segments must be connected via RS 485 repeaters.
- Ungrounded bus segments and grounded bus segments are connected via RS 485 repeaters.
- Each RS 485 repeater in the network reduces the maximum number of nodes per bus segment. This means that if there is an RS 485 repeater in a bus segment, the maximum number of other nodes is reduced to 31 for this segment. The number of RS 485 repeaters in the network, however, does **not** affect the maximum number of nodes on the network.

Up to 10 segments can be connected in series.

- Activate the terminating resistor on the first and last node in a segment.
- **Before** you include a new node in the MPI network, you must first turn off its power supply.

Recommendation for MPI Addresses on the Network

Avoid assigning the default MPI addresses (see below) as fixed node addresses in the network otherwise address conflicts can occur when you replace devices or expand the network (MPI addresses assigned twice).

- Reserve MPI address “0” for a service programming device
- Reserve address “1” for the C7 OP
- Reserve address “2” for the C7 CPU.

This avoids double assignment of MPI addresses if you install a further C7 or S7-300 with its default address (for example when replacing a C7).

Components

The individual components are interconnected via bus connectors and the PROFIBUS LAN cable. Remember to use a bus connector with a PG interface for nodes to which a PG might need to be connected (see also Section 3.5).

To connect two segments or to extend the length of the cable, use RS 485 repeaters.

Using the RS 485 Repeater

Installing and using the repeater is explained in the reference manual /71/.

Terminating Resistor

A cable must be terminated by its characteristic resistance. This is achieved simply by activating the integrated terminating resistor on the first and last node of a network.

Remember that the terminating resistor requires power to be effective. Make sure that the power supply to the nodes on which the terminating resistor is activated is on during startup and operation.

Terminating Resistor on the Bus Connector

Figure 3-1 shows you the switch settings for the terminating resistor on the bus connector.

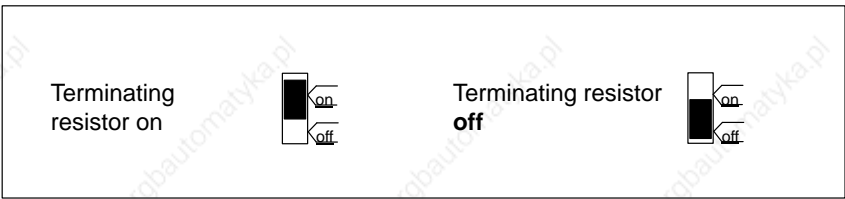

Figure 3-1 Terminating Resistor on the Bus Connector (On and Off)

Terminating Resistor on the RS 485 Repeater

Figure 3-2 shows the switches on the RS 485 repeater for activating the terminating resistor.

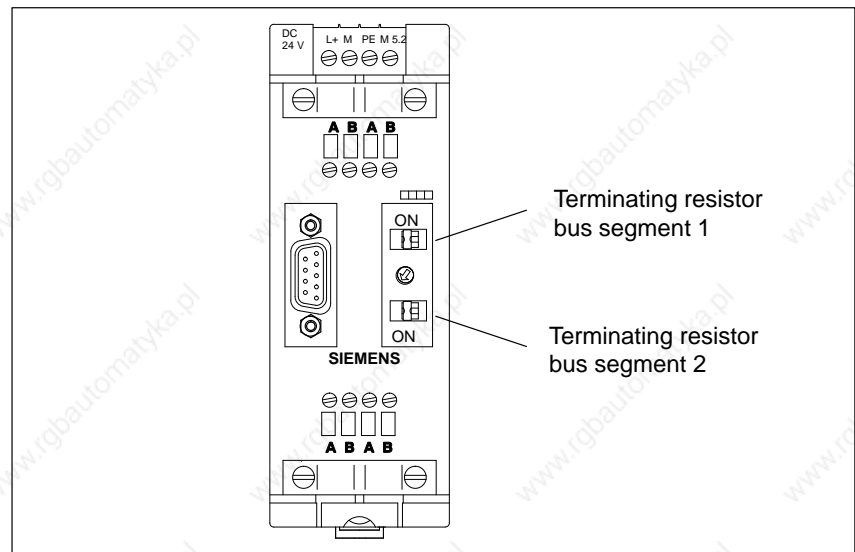

Figure 3-2 Terminating Resistor on the RS 485 Repeater

Example of Termination in an MPI Network

Figure 3-3 shows a possible MPI configuration in which the terminating resistor must be activated.

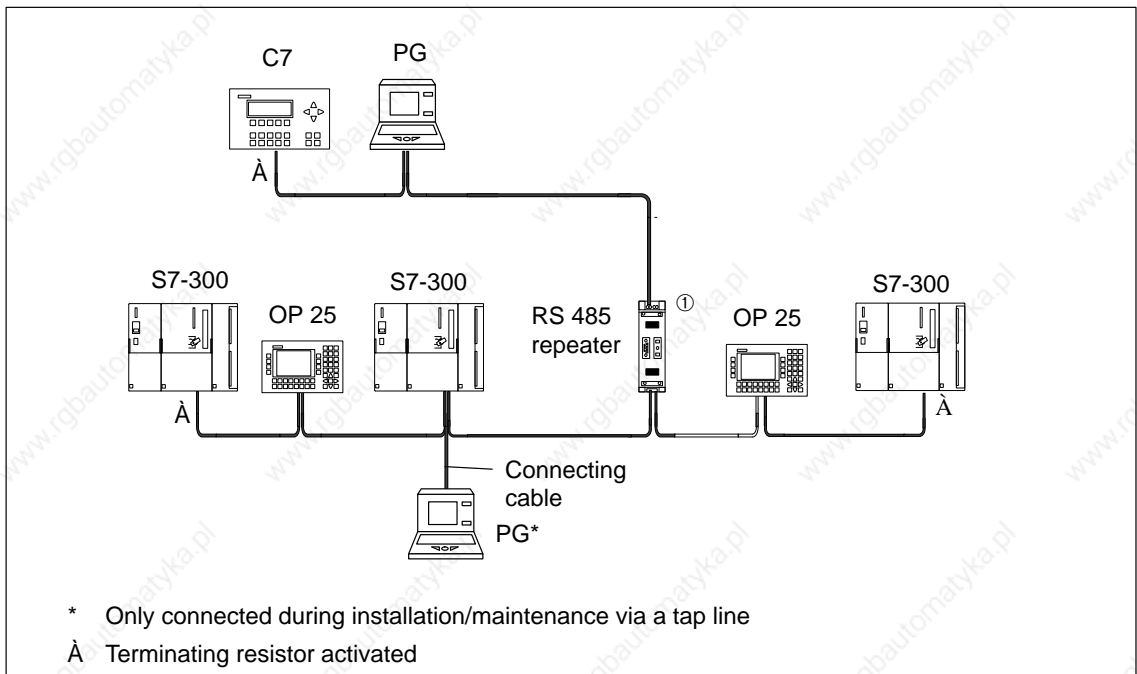

Figure 3-3 Activating Terminating Resistors in an MPI Network

Example of an MPI Subnet

Figure 3-4 shows the basic configuration of an MPI subnet using the rules listed above.

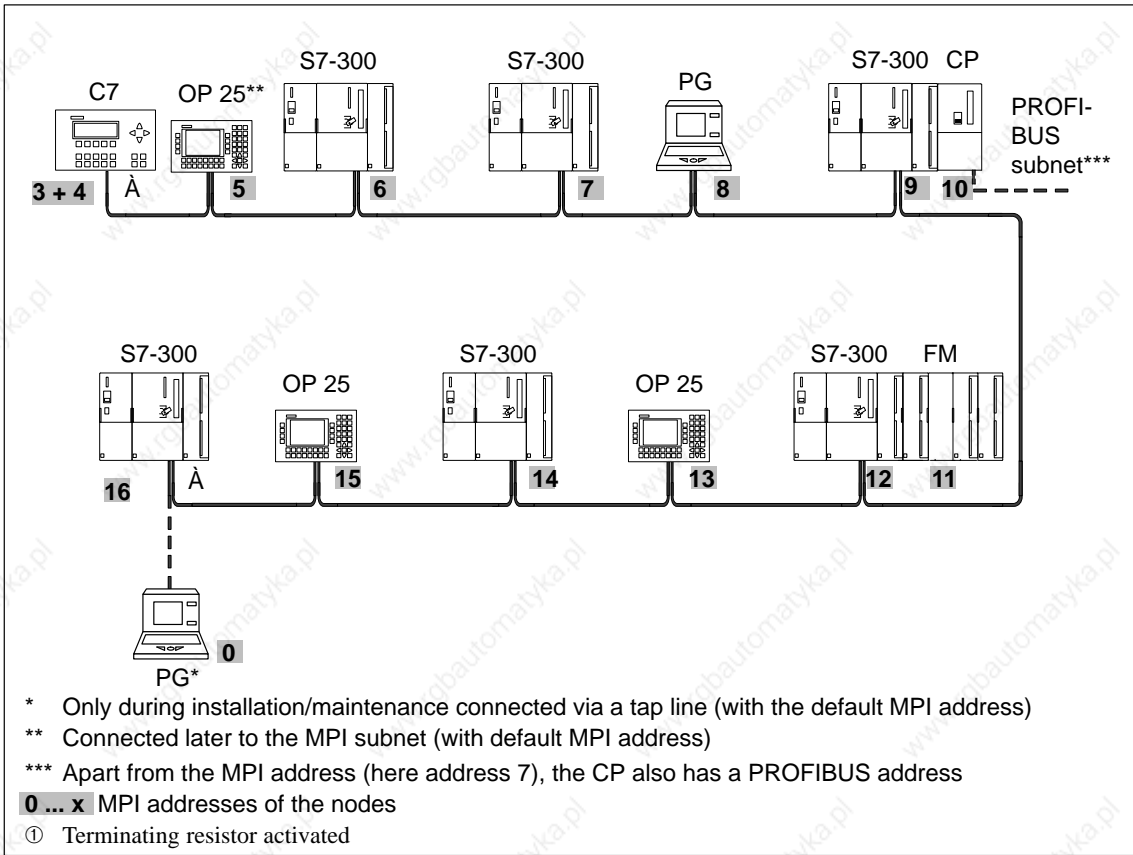

Figure 3-4 Example of an MPI Subnet

3.3 Cable Lengths

Segment in an MPI Network

The maximum cable length in one segment of an MPI network is 50 m. These 50 m represent the distance from the first node to the last node on the segment.

Longer Cable Lengths

If you require longer cable lengths than permitted in one segment, you must then use RS 485 repeaters. The maximum possible cable length between RS 485 repeaters corresponds to the cable length of a segment. Remember, however, that when using these maximum lengths, **no** further node (remote segment) can be located between the two RS 485 repeaters. You can connect up to nine RS 485 repeaters in series.

If you use an RS 485 repeater, remember that this must also be included in the number of nodes when calculating the number of nodes although it is not assigned its own MPI number.

Figure 3-5 shows how the cable for an MPI network can be extended using RS 485 repeaters.

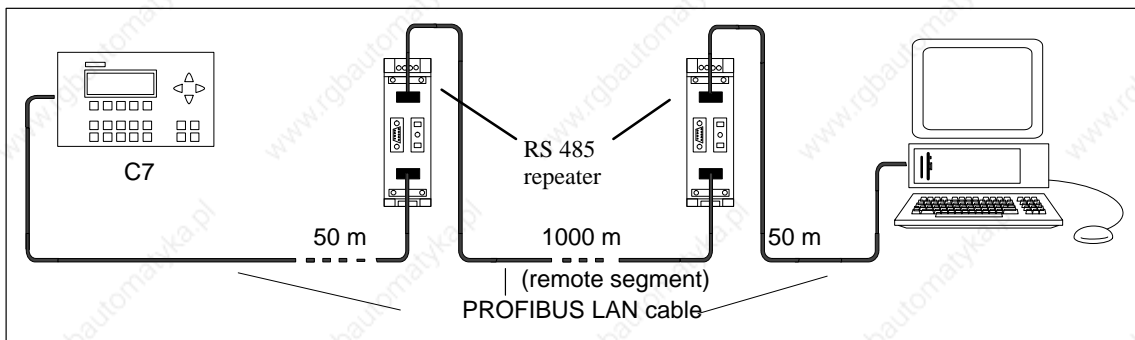

Figure 3-5 Maximum Cable Length Between Two RS 485 Repeaters

Tap Lines

Tap lines are cables with which the programming devices or OPs can be connected to the network for installation or during maintenance. Tap lines should be kept as short as possible. The number and length of tap lines that can be used is restricted.

The following table shows the maximum length of tap lines per bus segment:

Table 3-1 Length of the Tap Lines per Segment

Transmission Rate	Max. Length of Tap Line per Segment	Number of Nodes with Tap Line Lengths of ...	
		1.5 m or 1.6 m	3 m
187.5 Kbps	75 m	32	25

Example

Figure 3-6 shows a possible MPI network configuration. The example illustrates the distances that can be achieved in an MPI network.

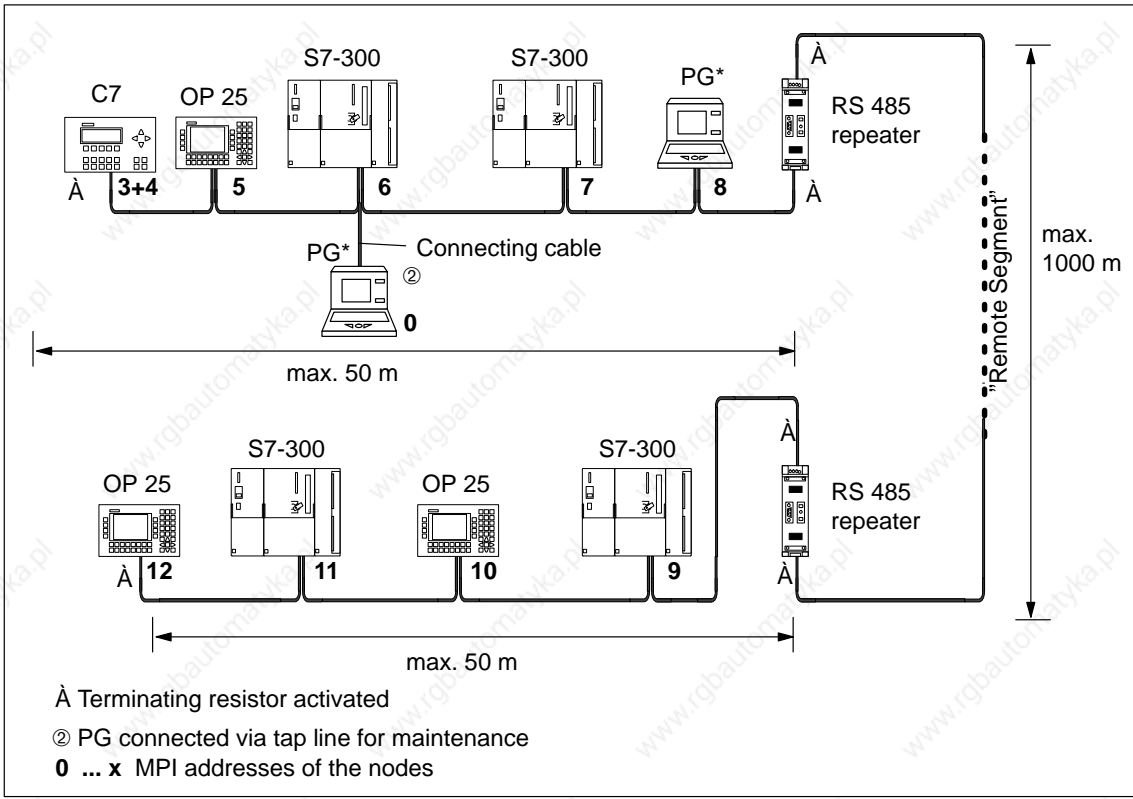

Figure 3-6 Cable Lengths in an MPI Network

3.4 Network Components

Purpose

You require network components in the following situations:

Table 3-2 Network Components

Purpose	Component
... to install the network	PROFIBUS LAN cable
... to connect a node to the network	Bus connector
... to amplify the signal ... to link segments	RS 485 repeater
... to convert signals for fiber-optic transmission (only PROFIBUS DP networks)	Optical link module
... to connect programming devices/OPs to the network	PG connecting cable (tap line)

PROFIBUS LAN Cable

The following PROFIBUS LAN cables are available:

Table 3-3 LAN Cables

PROFIBUS LAN cable	6XV1 830-0AH10
PROFIBUS underground cable	6XV1 830-3AH10
PROFIBUS trailing cable	6XV1 830-3BH10
PROFIBUS LAN cable with PE sheath (for the food, drinks and tobacco industry)	6XV1 830-0BH10
PROFIBUS LAN cable for festoons	6XV1 830-3CH10

Characteristics of the PROFIBUS LAN cable

The PROFIBUS LAN cable is a shielded twisted pair cable with the following characteristics:

Table 3-4 Characteristics of the PROFIBUS LAN Cable

Characteristics	Values
Characteristic resistance	Approx. 135 to 160 Ω ($f = 3$ to 20 MHz)
DC loop resistance	$\leq 115 \Omega/\text{km}$
Operating capacitance	30 nF/km
Attenuation	0.9 dB/100 m ($f = 200$ kHz)
Permitted core cross-section	0.3 mm ² to 0.5 mm ²
Permitted cable diameter	8 mm \pm 0.5 mm

Cabling Rules

When laying the PROFIBUS LAN cable, make sure you keep to the following rules:

- Do not twist the cable
- Do not stretch the cable
- Do not crimp the cable

When laying the interior LAN cable, the following restrictions must also be taken into account (d_O = outer diameter of the cable):

Table 3-5 Restrictions when Laying the Interior LAN Cable

Characteristics	Limits
Bending radius (bending once)	$\geq 80 \text{ mm } (10 \times d_O)$
Bending radius (repeated bending)	$\geq 160 \text{ mm } (20 \times d_O)$
Permitted temperature range during installation	- 5 °C to + 50 °C
Permitted temperature range during storage and when installed	- 30 °C to + 65 °C

3.5 Bus Connectors

Purpose of the Bus Connector

The bus connector is used to connect the PROFIBUS LAN cable to the MPI interface. This establishes the connection to further nodes.

There are five different bus connectors:

- Up to 12 Mbps PROFIBUS bus connector (6GK1500-0EA00)
- Up to 12 Mbps
 - Without PG interface (6ES7 972-0BA10-0XA0)
 - With PG interface (6ES7 972-0BB10-0XA0)
- Up to 12 Mbps, with swivelling cable outlet (straight or angled)
 - Without PG interface (6ES7 972-0BA20-0XA0)
 - With PG interface (6ES7 972-0BB20-0XA0)

No Area of Application

You do **not** require a bus connector for the RS 485 repeater.

3.5.1 PROFIBUS Bus Connector

**Appearance
(6GK1500-0EA00.)**

Figure 3-7 shows the PROFIBUS bus connector with order number 6GK1500-0EA00

Figure II:

Bus connector for the first and last node on the PROFIBUS network. The cable can be connected either from the left or right.

- ① Switch setting for the first and last station on the PROFIBUS network: “ON” (terminating resistor activated).
- ② The cable shield must lie on the bare metal.

Figure III:

- ① Terminator resistor deactivated.
- ② The cable shield must lie on bare metal.

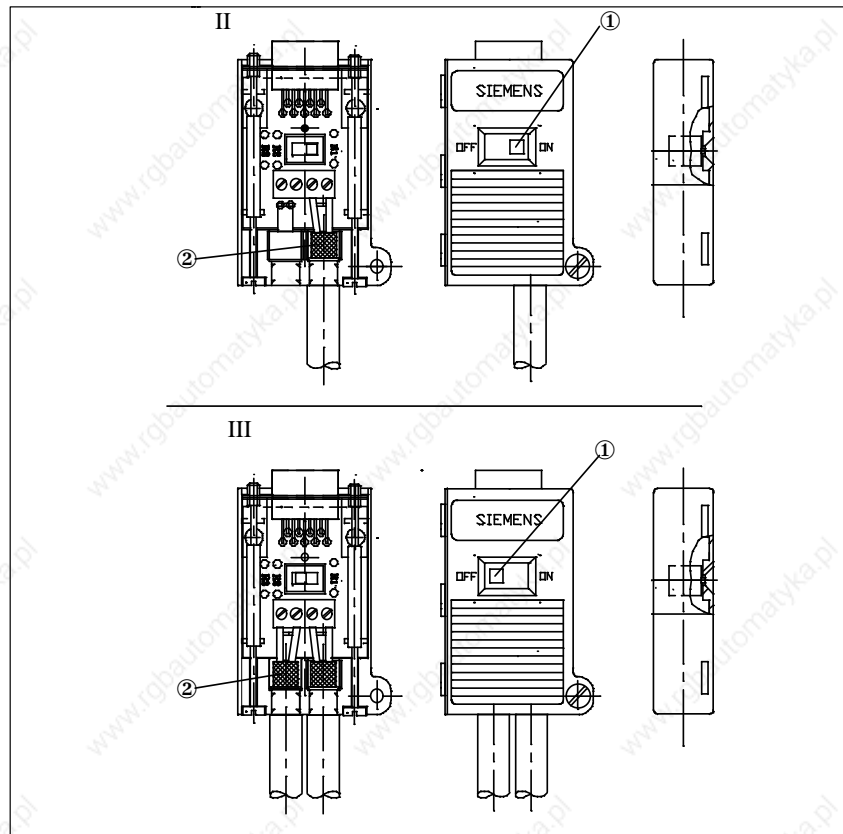

Figure 3-7 Appearance of the PROFIBUS Bus Connector

Fitting the Connector to the LAN Cable

Fit the PROFIBUS bus connector with order number 6GK1500-0EA00 to the LAN cable as follows:

1. Strip the cable.
2. Insert the green and red wires into the screw terminals.
3. Press the cable sheath between the two clips.
4. Tighten the screw terminals to secure the green and red wires.

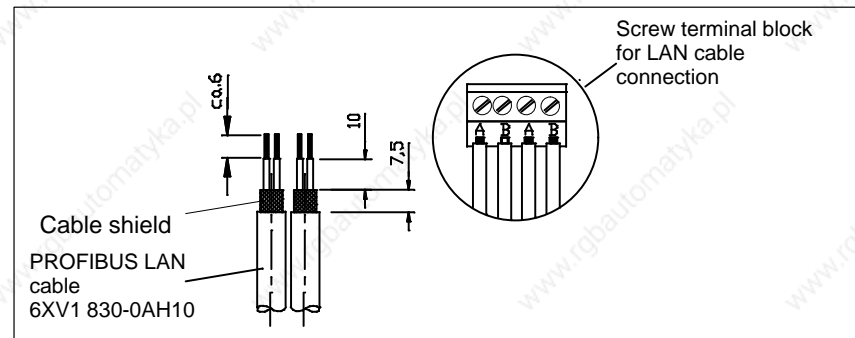

Figure 3-8 Connecting the PROFIBUS LAN Cable to the Screw Terminal Block

3.5.2 Bus Connector 6ES7 972-0B.20-0XA0

Appearance (6ES7-972-0B.20 ...)

Figure 3-9 shows the bus connector with order number 6ES7 972-0B.20 ...:

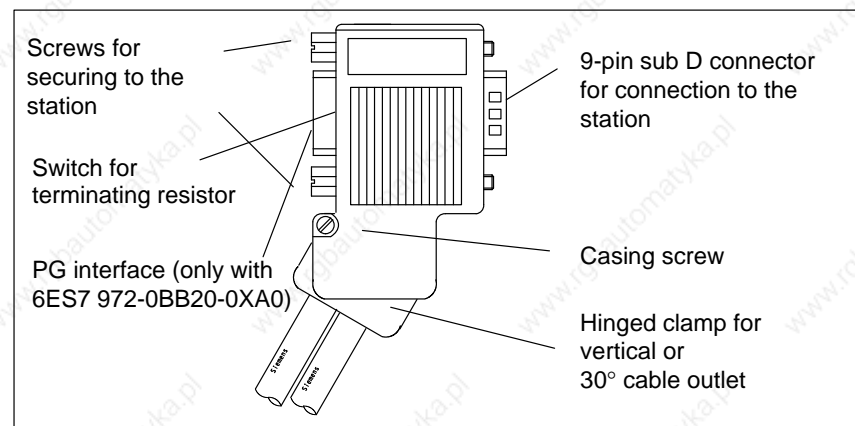

Figure 3-9 Appearance of the Bus Connector (Order Number 6ES7 972-0B.20 ...)

Fitting the Bus Connector to the LAN Cable

Fit the bus connector with order number 6ES7 972-0B.20 ... to the LAN cable as follows:

- Strip the insulation from the LAN cable as shown in Figure 3-10.

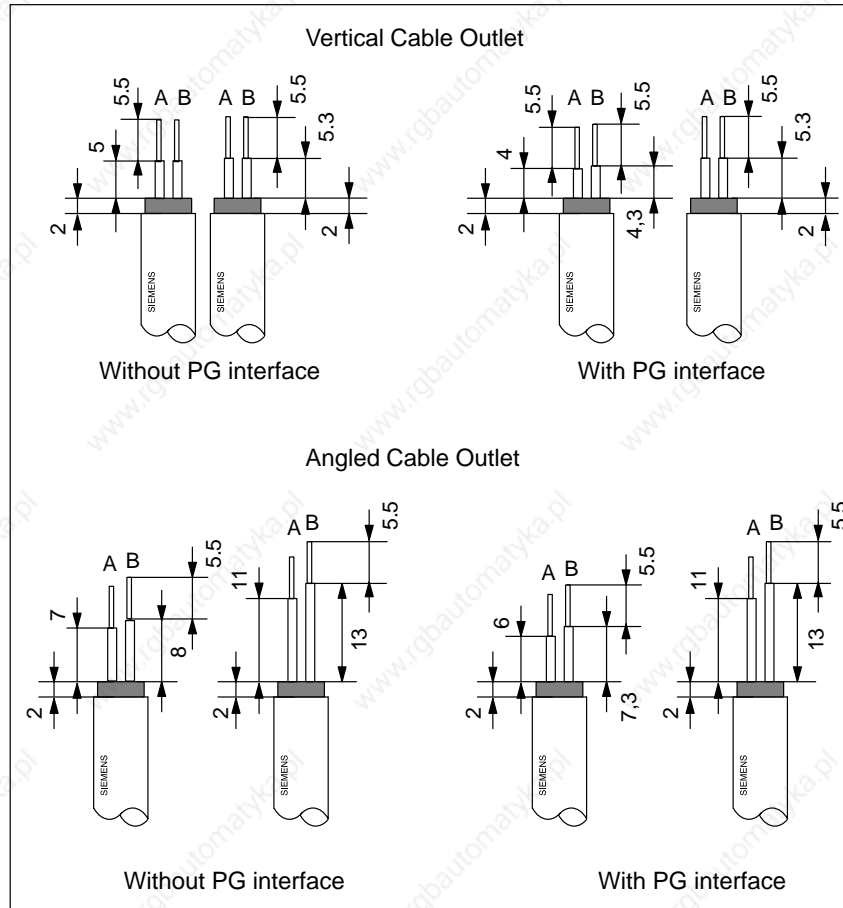

Figure 3-10 Length of Insulation to be Removed when Fitting the Bus Connector (6ES7 972-0B.20 ...)

- Open the casing of the bus connector by undoing the screw and lifting the cover.
- Release the cover of the hinged clamp.
- The bus connector with order number 6ES7 972-0B.20 is shipped with the cable outlet at 30 degrees.

If you require a vertical cable outlet,

- Loosen the left screw on the hinged clamp,
- Lever the hinged clamp upwards slightly
- Turn the hinged clamp inwards.
- To fix the clamp in position tighten the left screw again.

5. Fit the green and red wires into the screw terminal as shown in Figure 3-11.

Make sure that you always insert the same colored wire into the same terminal on all connectors (for example the green wire into terminal A and the red wire into terminal B, or vice-versa).

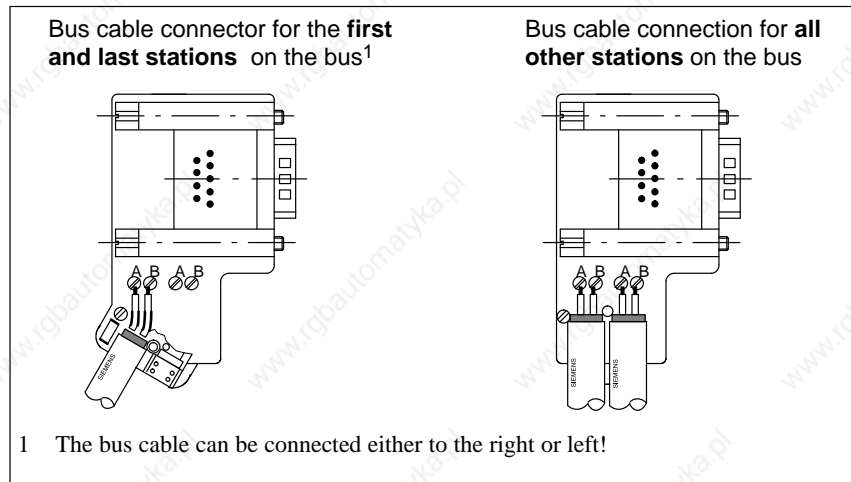

Figure 3-11 Fitting the Bus Connector (6ES7 972-0B.20 ...) to the LAN Cable

6. Screw down the hinged clamp again.

Make sure that the bare cable shield makes contact under the shield clamp.

7. Secure the green and red wires in the screw terminal.
8. Close the cover of the bus connector.
9. Tighten the cover screw.

3.5.3 Bus Connector 6ES7 972-0B.10-0XA0

Appearance Table 3-6 shows the bus connector 6ES7 972-0B.10-0XA0

Table 3-6 Description and Functions of the Bus Connector 6ES7 972-0B.10-0XA0

Front View of the Bus Connector		No.	Function
	①	Connection to the MPI, PROFIBUS DP interface (9-pin sub D connector)	
	②	Connector for the PROFIBUS LAN cable	
	③	Terminating resistor	
	④	Interface for PG/OP	
	⑤	Screws for fixing to the node	

Preparing the PROFIBUS LAN Cable for the Bus Connector

To connect the bus connector 6ES7 972-0B.10-0XA0 to the PROFIBUS LAN cable, follow the steps outlined below:

1. Cut the bus cable to the required length
2. Strip the insulation from the bus cable as shown in Figure 3-12.

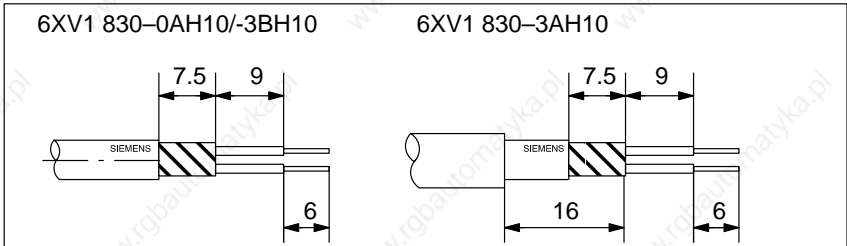

Figure 3-12 Preparing the LAN Cable for Connecting the Bus Connector 6ES7 972-0B.10-0XA0

3. Open the housing of the bus connector by undoing the screws in the housing.
4. Remove the cover.

5. Fit the green and red wires into the screw terminal block as shown in Figure 3-13.

Make sure that you always fit the same wires to the same terminal A or B (for example always connect the green wire to terminal A and the red wire to terminal B or vice-versa).

6. Press the cable sheath between the two clips. This fixes the cable in position.
7. Tighten the screw terminals for the green and red wires.

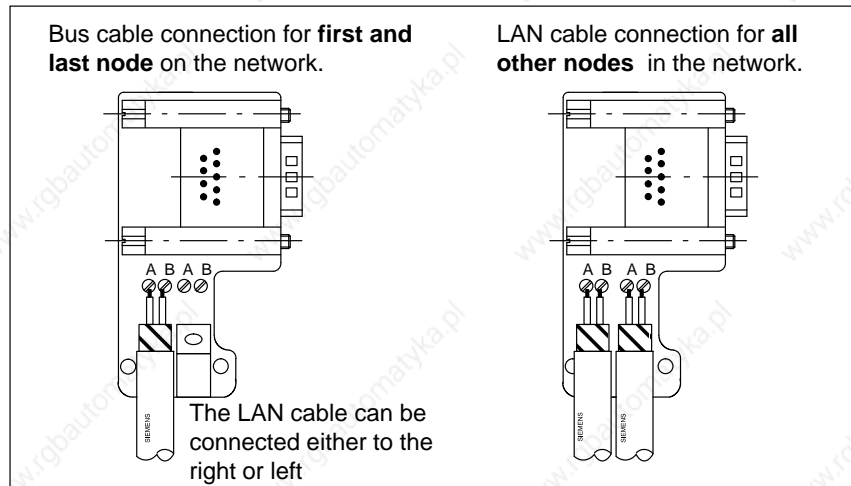

Figure 3-13 Connecting the LAN Cable to the Bus Connector
6ES7 972-0B.10-0XA0

8. Close the housing again using the screws.
Make sure that the cable shield makes contact below the shield clamp.

3.5.4 Connecting the Bus Connector to a Module

Connecting the Bus Connector

To connect the bus connector, follow the steps outlined below:

1. Plug the bus connector into the module.
2. Screw the bus connector securely to the module.
3. If the bus connector with the order number 6ES7 ... is located at the start or end of a segment, you must activate the terminating resistor (switch setting "ON") (see Figure 3-14).

Note

The bus connector 6ES7 972-0BA30-0XA0 does not have a terminating resistor. You cannot plug in this bus connector at the start or end of a segment.

Make sure that the stations on which the terminating resistor is located are always turned on during startup and operation.

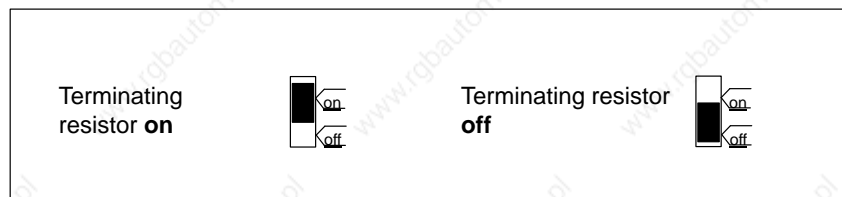

Figure 3-14 Bus Connector (6ES7 ...): Terminating Resistor Activated and Deactivated

Removing the Bus Connector

You can remove the bus connector with a **LAN cable connected through** at any time from the PROFIBUS DP interface without interrupting the data exchange on the bus.



Warning

Disturbance of data exchange on the bus is possible!

A bus segment must always be terminated at both ends. This is, for example, not the case if the power supply to the last slave with a bus connector is not turned on. Since the bus connector takes its power from the station, this would make the terminating resistor ineffective.

Make sure that the stations on which the terminating resistor is activated, are always turned on.

Connecting a Programming Device / PC to a C7

4

Chapter Overview

Section	Description	Page
4.1	Connecting a Programming Device/PC to a C7	4-2
4.2	Connecting a Programming Device/PC to Several Nodes	4-3

4.1 Connecting a Programming Device / PC to a C7

Possibilities

This chapter explains the ways in which you can connect a programming device or PC to the C7 via the multipoint interface.

Cable Lengths

For information about the possible cable lengths, refer to Section 3.3.

Connecting a Programming Device/PC to a C7

You can connect a programming device or PC to the MPI port of the C7 using a preassembled PG cable.

As an alternative, you can use PROFIBUS LAN cable and bus connectors to make your own connecting cable (see Section 3.5).

Figure 4-1 shows the components for connecting a programming device/PC to a C7.

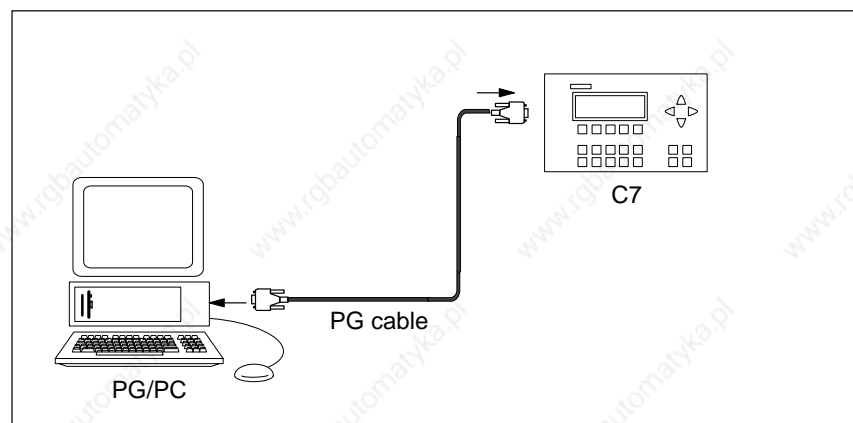

Figure 4-1 Connecting a Programming Device/PC to a C7

4.2 Connecting a Programming Device/PC to Several Nodes

Possibilities

This section explains how to connect a programming device or PC to more than one node networked via the multipoint interface.

Two Installation Options

When you connect a programming device/PC to more than one node, you must distinguish between two different types of connection:

- Fixed installation of the programming device/PC in the MPI network
- Programming device/PC connected only for installation and maintenance work.

Depending on the network attachment, you connect the programming device/PC with other nodes as follows (see also Section 3.2).

Network Attachment	Connection
Programming Device/PC installed permanently in the network.	The programming device/PC is included directly in the MPI network.
PG/PC attached for installation and maintenance.	The programming device/PC is connected to a node via a tap line.

Permanently Installed Programming Device/PC

You connect the permanently installed PG/PC in the MPI network to one or more nodes of the MPI network according to the rules explained in Section 3.2.

Figure 4-2 shows a C7 network with two C7s. The two C7s are interconnected using a PROFIBUS LAN cable.

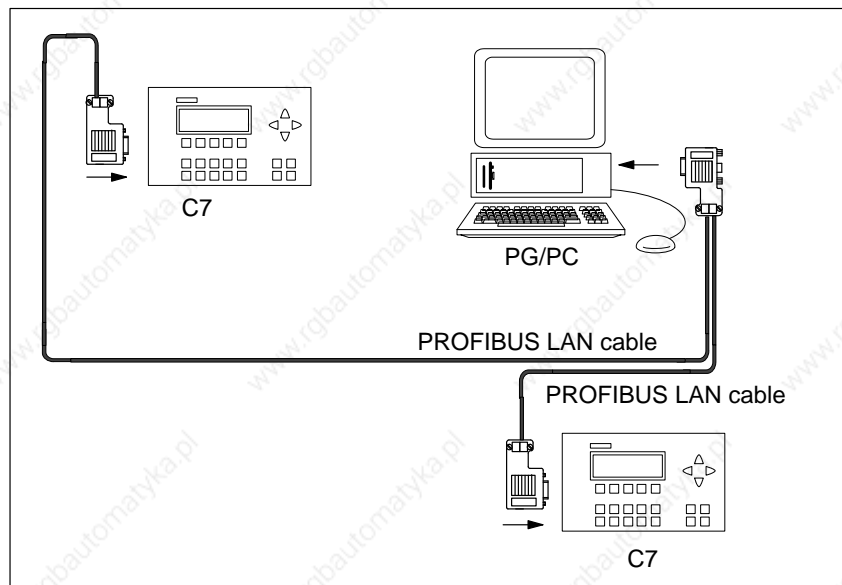

Figure 4-2 Connecting a PG/PC to more than One C7

Connecting a Programming Device/PC when Service is Required

If there is no stationary programming device/PC, we recommend the following procedure:

To attach a programming device/PC to an MPI network with an “Unknown” node address, it is advisable to set the following address on the service programming device/PC:

- MPI address: 0
- Highest MPI address: 126.

Following this, use the STEP 7 function *Hardware Configuration* to find out the highest MPI address in the MPI network and then set the highest MPI address on the programming device/PC to the same value as that of the MPI network.

Programming Device/PC for Installation or Maintenance

For installation or maintenance purposes, attach the programming device/PC to a node of the MPI network using a tap line. The bus connector of this node must have a PG interface (see also Section 3.5).

Figure 4-3 shows two networked C7s to which a programming device/PC is connected.

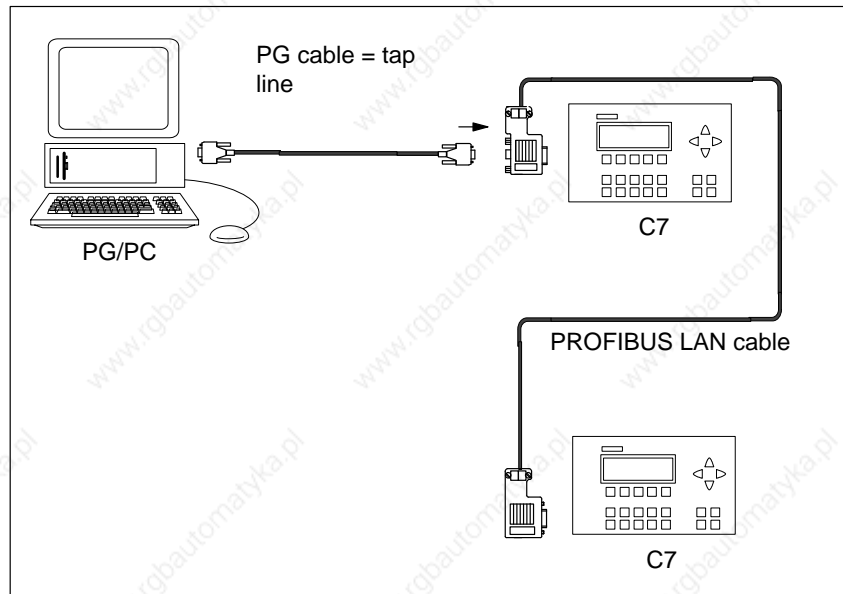

Figure 4-3 Attaching a Programming Device/PC to an MPI Network

Attaching a Programming Device to an Ungrounded Node

If you install the nodes of a subnet or an S7-300 without grounding, only an ungrounded programming device can be connected to the subnet or to the S7-300.

Connecting a Grounded Programming Device to the MPI

You want to use ungrounded nodes. If the MPI is grounded on the PG, you must include an RS 485 repeater between the nodes and the PG. The ungrounded nodes must be connected to bus segment 2 if the PG is connected to bus segment 1 (terminals A1 B1) or the programming device/OP interface (see Chapter 7 in the reference manual *Module Data*).

Figure 4-4 shows the RS 485 repeater as an interface between a grounded and an ungrounded node in an MPI subnet.

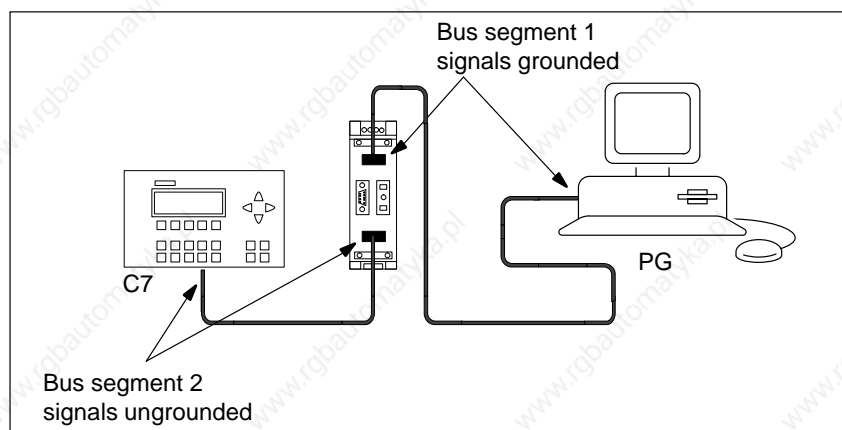

Figure 4-4 PG Connected to an Ungrounded S7-300

Attaching a C7-621 AS-i

5

Note

The information in this chapter applies only to the C7-621 AS-i.

5.1 AS-i Attachments

Properties

The C7-621 AS-i has connectors for two AS-i cables that are connected internally in the C7. The maximum load on the contacts is 4 A.

You can connect the following to the AS-i connectors:

- Actuators, sensors
- AS-i power supply unit

AS-i CP Power Supply

The AS-i CP is not supplied with power via the 24V DC input. The AS-i CP must be supplied with power via terminals AS-i+ and AS-i-.

AS-i Power Supply Unit

Connect the power supply unit either directly to the C7-621 AS-i or supply power to the AS-i CP in the C7-621 AS-i by connecting the AS-i power supply in the network with the actuators or sensors.

Connections and Block Diagram

Figure 5-1 shows the connections and block diagram of the AS-i terminals.

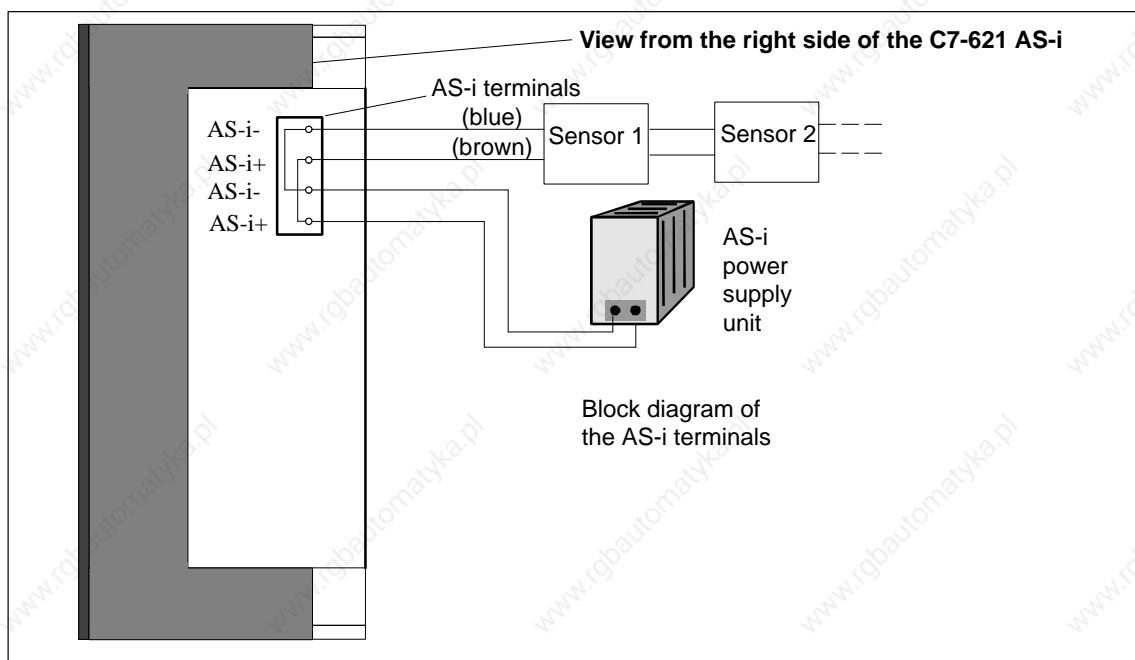

Figure 5-1 Connections and Block Diagram of the AS-i Terminals

5.2 The AS-i Cable

Overview

The AS-i cable (a profile cable) allows simple and fast installation of an AS-i system. The AS-i cable is a rubberized 2-wire cable ($2 \times 1.5 \text{ mm}^2$). The special profile of the cable prevents polarity reversal when connecting nodes.

Attaching to the AS-i Cable

Attachments are made to the AS-i cable using the penetration technique. Contacts penetrate the rubberized jacket and make contact to the two cores. This guarantees a low transition resistance and a reliable data connection. The cable does not need to be cut, stripped or screwed. To attach to the network, there are coupling modules that use the penetration technique.

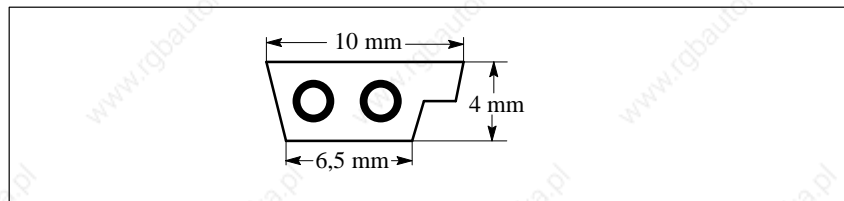

Figure 5-2 Cross-Section of the Cable

The jacket of the AS-i cable is rubber. If it becomes necessary to move modules after they have been connected to the AS-i cable, this can be done without any problem. The AS-i cable is self-healing. This means that the holes made by the contacts penetrating the jacket close automatically and re-establish degree of protection IP67. When the cable is installed in an AS-i module, the cable seals the cable inlets. This allows degree of protection IP67 to be achieved.

Using Other 2-Wire Cables

Apart from the special AS-i cable, any 2-wire cable with a cross-section of $2 \times 1.5 \text{ mm}^2$ can be used. Shielding or twisting is not necessary. For the change from the special AS-i cable to another cable (for example a standard round cable), there is a special module without integrated electronics available (transition from the AS-i cable to four M12 terminals and transition from the AS-i cable to one M12 terminal).

Operation and Display Elements

How to use the AS-i CP and the meaning of the displays on the AS-i module are described in Volume 2 Section 6.4.

C7-621 Digital I/Os

6

Chapter Overview

Section	Description	Page
6.1	Digital Inputs	6-2
6.2	Digital Outputs	6-4
6.3	Status Displays of the DI/DO	6-7

Note

The information this chapter applies only to the C7-621. The C7-621 AS-i does not have digital I/Os.

6.1 Digital Inputs

Characteristics

The digital inputs have the following characteristics:

- 16 inputs, non-floating
- Rated input voltage: 24V DC
- Suitable, for example, for switches and 2-wire proximity switches (BEROs)

Terminals and Block Diagram

Figure 6-1 shows the terminals and block diagram of the digital inputs.

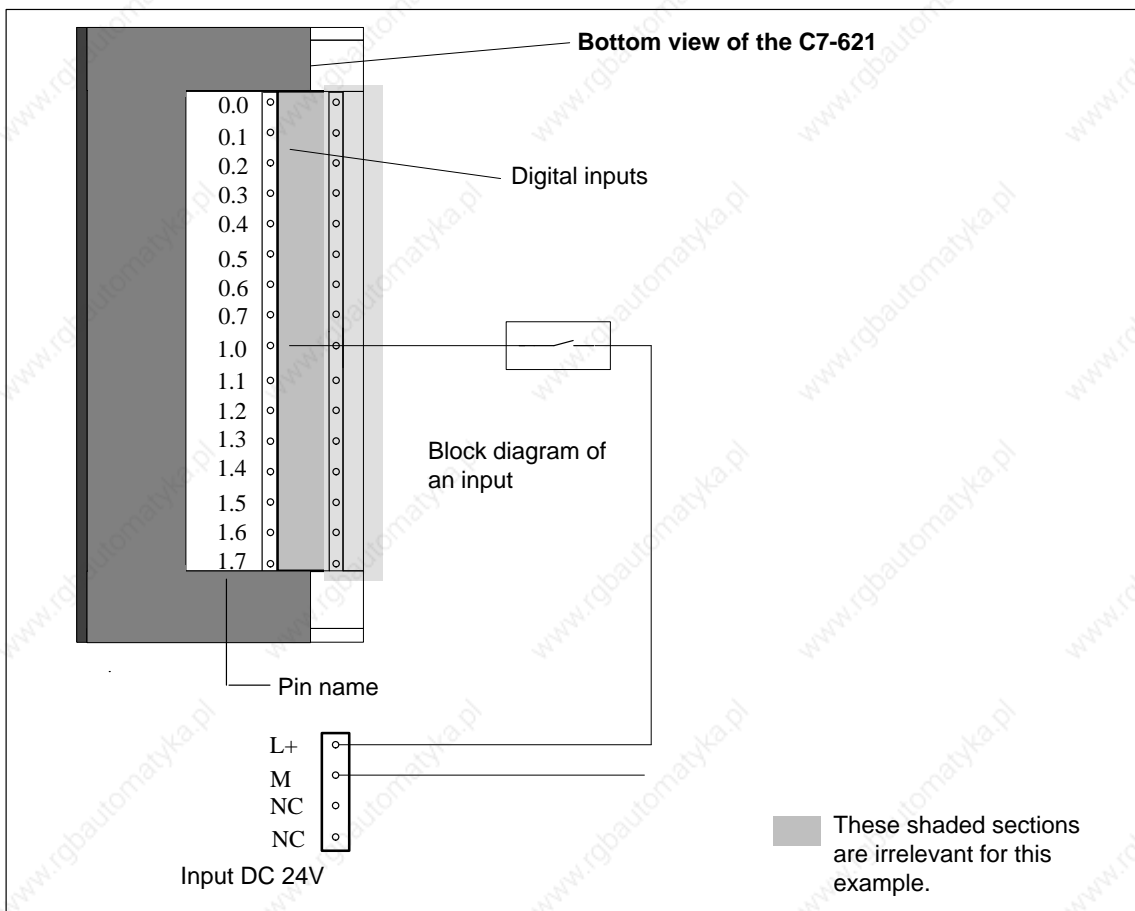

Figure 6-1 Terminals and Block Diagram of the Digital Inputs

Digital Input

The following table shows the technical data of the digital inputs of the C7 CPU.

Module-Specific Data		Status, Interrupt, Diagnostics	
Number of inputs	16	Interrupts	no
Cable length		Diagnostic functions	no
• Unshielded	max. 600 m	Data for Selecting a Sensor	
Voltages, Currents, Potentials		Input voltage	
Rated load voltage L+	DC 24 V	• Rated value	DC 24 V
• Reverse polarity protection	yes	• For signal "1"	11 to 30 V
Number of simultaneously accessible inputs	16	• For signal "0"	-3 to +5 V
Floating	no	Input current	
		• For signal "1"	Typically 7 mA
		Input delay	
		• From "0" to "1"	1.2 to 4.8 ms
		• From "1" to "0"	1.2 to 4.8 ms
		Input characteristics	Complying with IEC 1131, Type 2
		Connection of 2-wire BEROs	Possible
		• Permitted closed-circuit current	max. 2 mA

6.2 Digital Outputs

Properties

The digital outputs have the following properties:

- 16 outputs, non-floating
- Output current 0.5 A
- Rated load voltage: 24V DC
- Suitable, for example, for solenoid valves and DC contactors.

Note

When the power supply is turned on, the digital output applies a pulse to the outputs. Within the permitted output current range, a pulse can be approximately 50 μ s long.

Terminals and Block Diagram

Figure 6-2 shows the terminals and block diagram of the digital outputs. The following page has more detailed technical data about the digital outputs.

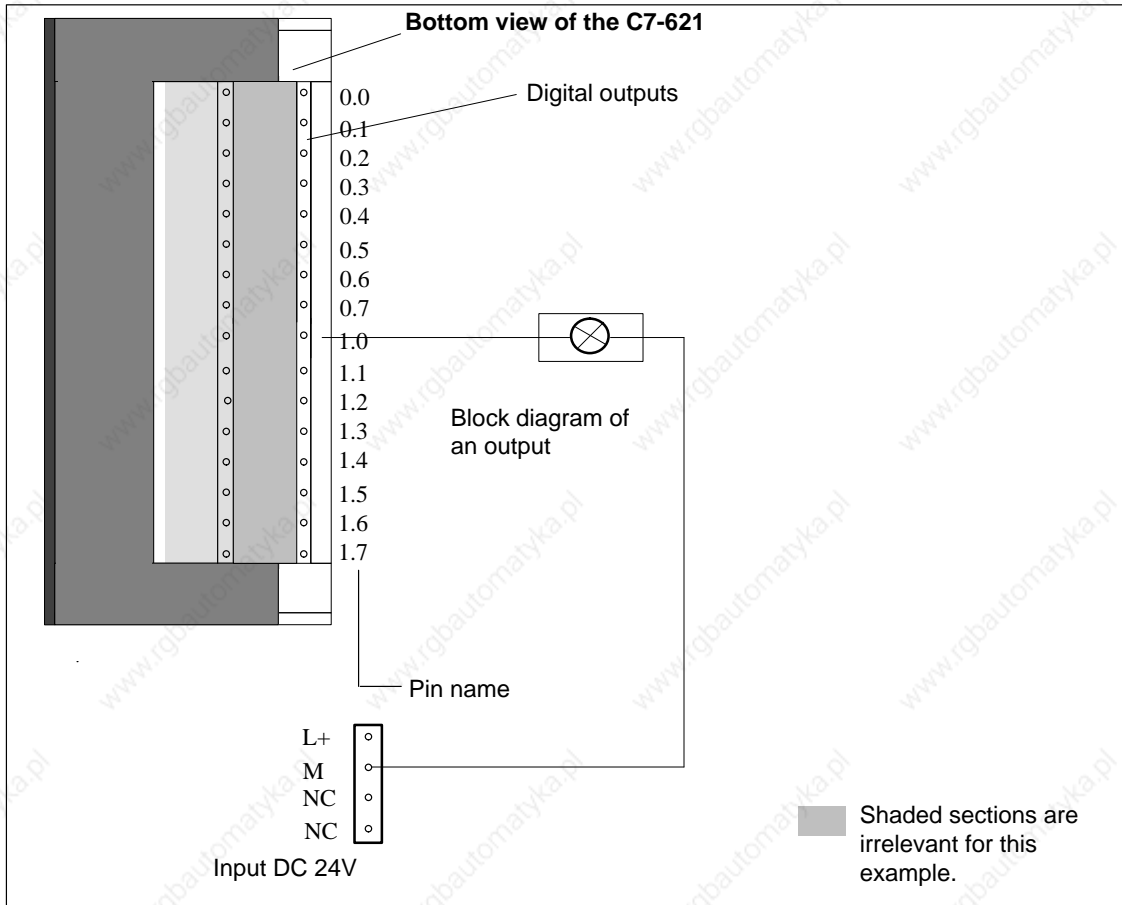

Figure 6-2 Terminals and Block Diagram of the Digital Outputs

Digital Outputs

The following table shows the technical data of the digital outputs of the C7 CPU.

Module-Specific Data		Data for Selecting an Actuator	
Number of outputs	16	Output voltage	
Cable length		• At signal "1"	min. L+ (- 0.8 V)
• Unshielded	max. 600 m	Output current	
Voltages, Currents, Potential		• For signal "1"	
Rated load voltage L+	24 V DC, 0.5 A	Rated value	0.5 A
• Reverse polarity protection	no	Permitted range	5 mA to 0.6 A
Total current of the outputs (per group: 0.0 to 0.7 or 1.0 to 1.7)		• For signal "0" (residual current)	max. 0.5 mA
• Up to 20 °C	max. 4 A	Load resistance range	48 Ω to 4 kΩ
• Up to 45 °C	max. 2 A	Lamp load	max. 5 W
Floating	no	Parallel connection of 2 outputs	
Status, Interrupts, Diagnostics		• For redundant activation of a load	Possible, only outputs of the same group
Interrupts	no	• For increased power	Not possible
Diagnostic functions	no	Activation of a digital input	Possible
		Switching frequency	
		• With ohmic load	max. 100 Hz
		• With inductive load to IEC 947-5-1, DC 13	max. 0.5 Hz
		• With lamp load	max. 100 Hz
		Limitation (internal) of the inductive cut-off voltage	Typically L+ (- 48 V)
		Short circuit protection of the output	Yes, clocked electronically
		• Switching threshold	Typically 1 A

6.3 Status Displays of the DI/DO

Overview

The status of the digital I/Os can be displayed with one of the C7 system functions. The values are read as direct process values (PIW) of the DI and as the process image (QW) of the DO C7 I/Os and displayed in the format BIN. It is not possible to modify the display.

In the STOP mode, the real process status for DO = 0. The displayed process image can deviate from this; the displayed image represents the last image set by the control program.

Selecting the DI/DO Status Display

You can select the DI/DO status display without an operator password. The DI/DO status display can be selected in the system functions menu by pressing the **F5** key.

The following data are displayed:

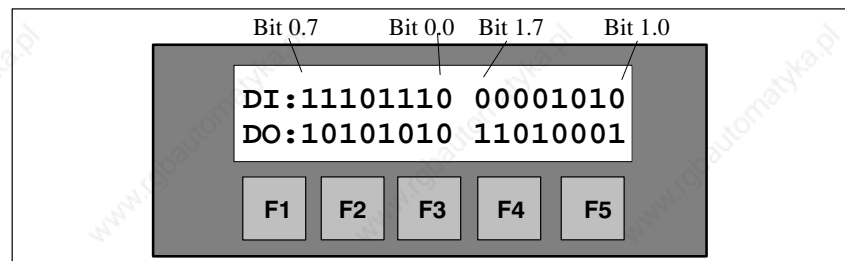

Figure 6-3 Example of a Status Display on a C7-621

Table 6-1 Explanation of the DI/DO Status Display in Figure 6-3

Display	Explanation
1	DI/DO set
0	DI/DO reset

Note

The values of the DI/DO are read in at one second intervals and displayed. Changes taking place between these two points are not displayed.

Quitting the DI/DO Display

You quit the DI/DO status display by pressing the **ESC** key. If you do not quit explicitly, the C7-621 changes automatically to the C7-621 idle message after approximately one minute.

Quitting the System Functions Menu

You quit the **system functions menu** by pressing the **ESC** key.

C7-621 Analog I/Os

7

Chapter Overview

Section	Description	Page
7.1	Connecting Sensors to Analog Inputs	7-2
7.1.1	Connecting Voltage and Current Sensors	7-5
7.2	Connecting Loads/Actuators to the Analog Output	7-7
7.3	Analog Input	7-10
7.3.1	Properties and Technical Data of the Analog Input	7-11
7.4	Analog Output	7-15

Ungrounded Configuration

It is not possible to include the C7 in an ungrounded configuration.

Note

The information in this section applies only to the C7-621. The C7-621 AS-i does not have analog I/Os.

7.1 Connecting Sensors to Analog Inputs

Overview

Depending on the type of measurement, you can connect various sensors to the analog inputs:

- Voltage sensors
- Current sensors

This section describes how to connect sensors and points to note when connecting them.

Cables for Analog Signals

You should use shielded, twisted pair cables for analog signals. This reduces the effects of noise. The shield of the analog cables should be grounded at both ends. If there are potential differences between the ends of the cable, an equipotential current can flow through the shield and cause disturbances to the analog signals. In this case you should only ground the cable at one end.

Connecting Sensors to Analog Inputs

A potential difference U_{CM} (common mode voltage) may occur between the cable AIX-M of the input channels and the reference point of the measuring circuit M. This potential difference must, however, not exceed the permitted limit value (see technical data). If it is possible that the permitted value for U_{CM} will be exceeded or if you cannot measure the potential difference exactly, you must connect AIX-M with M. This also applies to unused inputs.

Abbreviations

The following abbreviations are used in Figures 7-1 to 7-4:

AIX-X: Measuring cable AIX-U or AIX-I

AIX-M: Reference potential of the measuring cable

M: Chassis connection of C7-621 and
Reference potential of the analog measuring circuit

(functional earth )

U_{CM} : Potential difference between inputs and M

Isolated Sensors

Isolated sensors are not connected to the local ground. They can be operated as floating sensors. Due to the local conditions or noise, potential differences U_{CM} (static or dynamic) can occur between the measuring cables AIX-M of the input channels and the reference point of the measuring circuit M. This potential difference must, however, not exceed the maximum permitted value. If it is possible that the value will exceed the maximum permitted value for U_{CM} or if you cannot measure the potential difference exactly, you must connect AIX-M with M.

Figure 7-1 shows the connection of isolated sensors to a non-floating analog input.

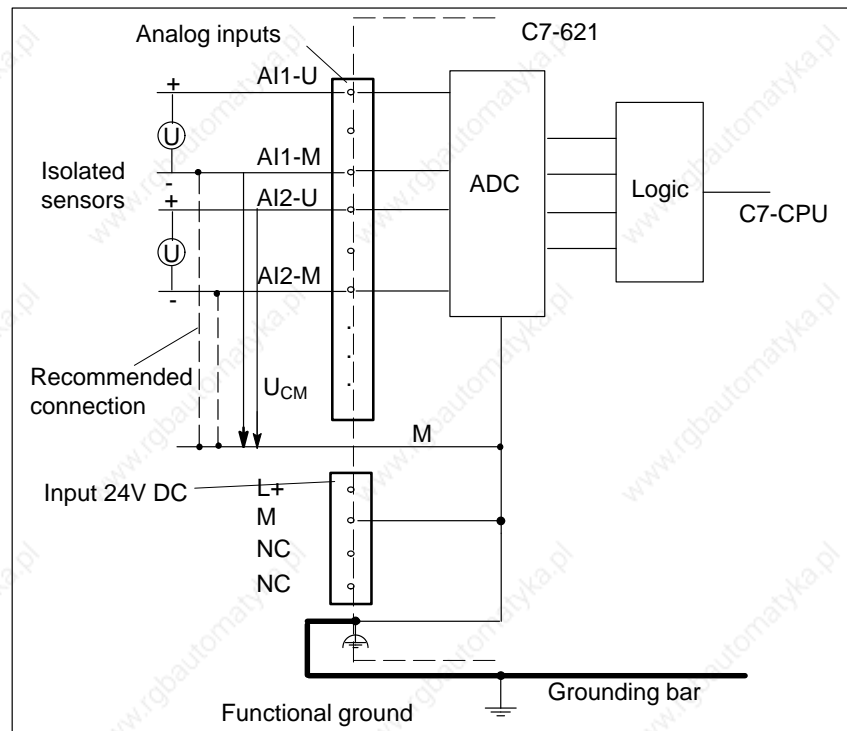

Figure 7-1 Connection of Isolated Sensors to a Non-Floating Analog Input

Non-Isolated Sensors

Non-isolated sensors are connected to ground locally. Due to local conditions or noise, potential differences (static or dynamic) can occur between the locally distributed measuring points. To avoid these potential differences, you should install equipotential bonding cables between the measuring points.

Potential differences U_{CM} (static or dynamic) can also occur between the measuring cables AI_X-M of the input channels and the reference point of the measuring circuit M . This potential difference must not exceed the maximum permitted value. If it is possible that this will exceed the maximum permitted value for U_{CM} or if you cannot measure the potential difference exactly, AI_X-M must be connected to M .

Figure 7-2 shows the connection of non-isolated sensors to a floating analog input module.

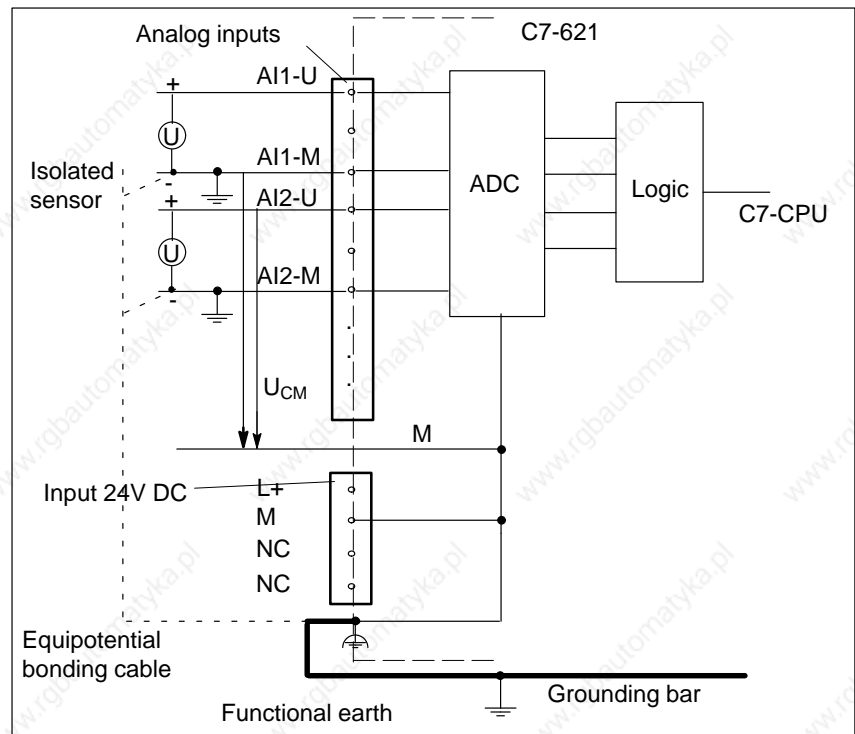



Figure 7-2 Connecting Non-Isolated Sensors to a Floating Analog Input

7.1.1 Connecting Voltage and Current Sensors

Abbreviations

The abbreviations in Figures 7-3 to 7-4 have the following meaning:

- AIx-X: Measuring cable AIx-I or AIx-U
- AIx-M: Measuring cable reference potential
- M: Reference potential of the analog measuring circuit (functional ground )

Connecting Voltage Sensors

Figure 7-3 shows the connection of voltage sensors to a non-floating analog input.

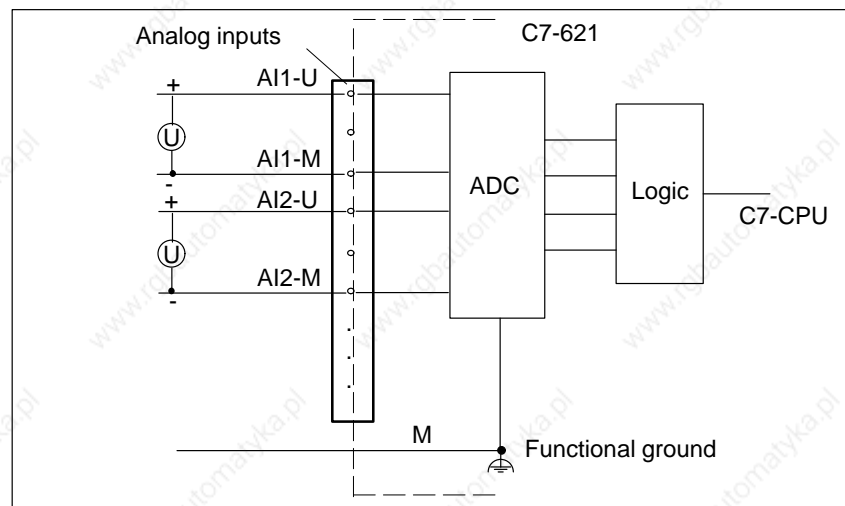

Figure 7-3 Connecting Non-Isolated Sensors to a Non-Floating Analog Input

Connecting Sensors as 4-Wire Transducers

4-wire transducers have a separate power supply U_H . Figure 7-4 shows the connection of sensors as 4-wire measuring transducers to a non-floating analog input.

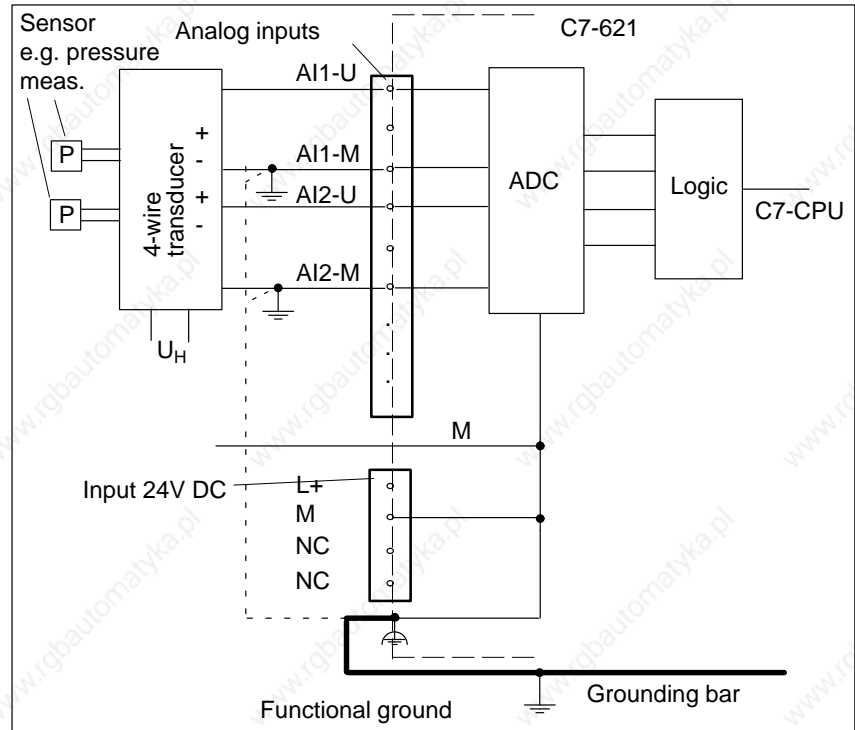

Figure 7-4 Connecting 4-Wire Transducers to a Non-Floating Analog Input

Note

2-wire transducers cannot be operated with the C7 units.

7.2 Connecting Loads/Actuators to the Analog Output

Overview With the analog output, you can supply loads/actuators with current or voltage.

Cables for Analog Signals You should use shielded, twisted pair cables for analog signals. This reduces the effects of noise. The shield of the analog cables should be grounded at both ends. If there are potential differences between the ends of the cable, an equipotential current can flow through the shield and cause disturbances to the analog signals. In this case you should only ground the cable at one end.

Abbreviations The abbreviations used in Figures 7-5 to 7-6 have the following meaning:

- AO-I: Analog output current
- AO-U: Analog output voltage
- R_L: Load/actuator
- AO-M : Chassis connection (reference potential of the analog output)
- L+: Power supply connection 24 V DC
- M: Chassis connection of the C7

Figures 7-5 to 7-6 show how the loads/actuators must be connected to the current or voltage outputs of the analog output module.

Connecting Loads to a Current Output

To connect a load to a current output, you must connect AO-M to a AO-I and the reference point of the analog circuit.

Figure 7-5 shows the connection of loads to a current output of a non-floating analog output module.

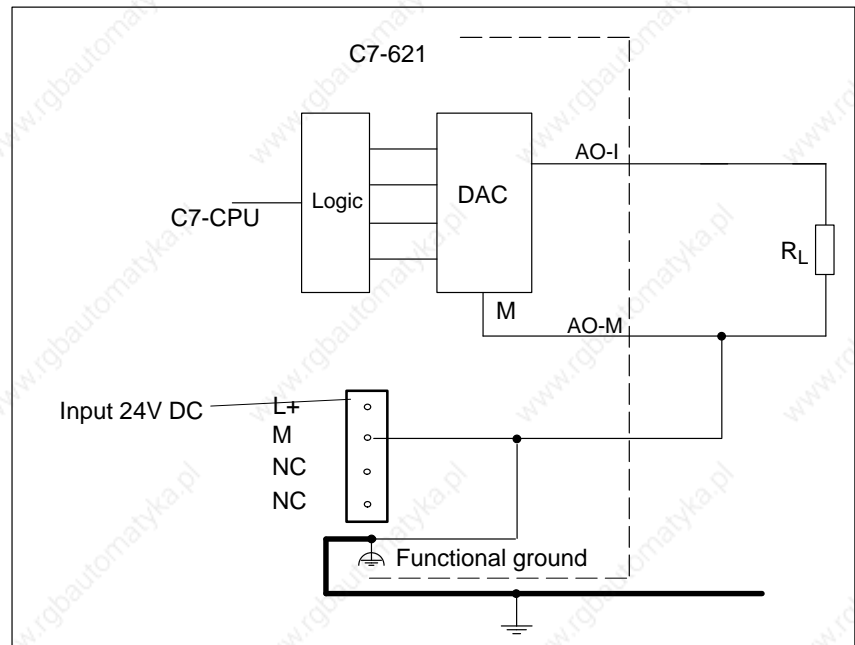

Figure 7-5 Connecting Loads to a Current Output of a Non-Floating Analog Output

Connecting Loads to a Voltage Output

Connecting loads to a single voltage output is only possible with a 2-wire connection.

2-Wire Connection

The connection of loads to a voltage output using a 2-wire connection is made at the analog output AO-U and the reference point of the measuring circuit AO-M.

Figure 7-6 shows the connection of loads to a voltage output of a non-floating analog output module with a 2-wire connection.

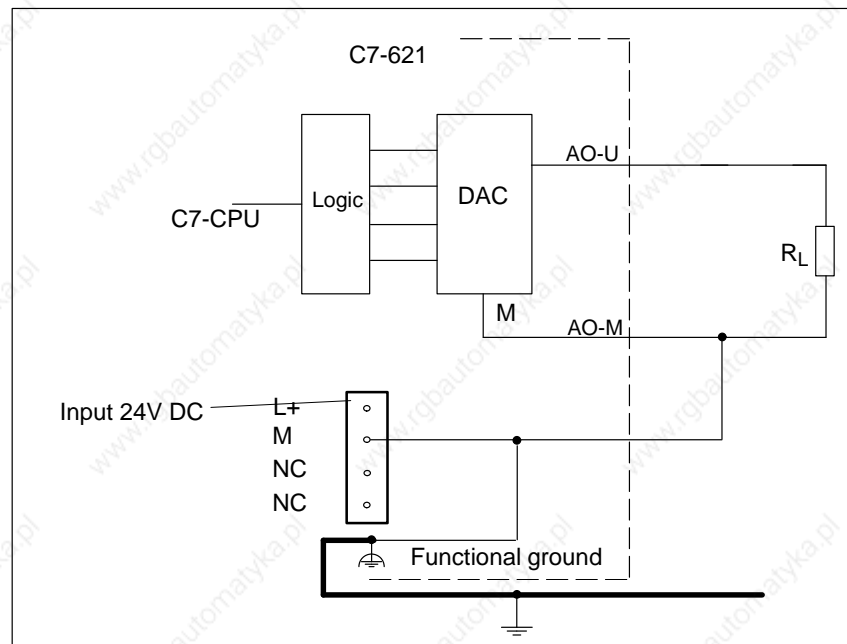

Figure 7-6 Connection of Loads to a Voltage Output of a Non-Floating Analog Output Module

7.3 Analog Input

Contents

This section explains the following:

- The properties of the analog input module
- The technical data of the analog input module

You will learn the following:

- How to install the analog input module
- Which measuring ranges are provided by the analog input module

Selectable Types of Measurement

The following measurement types are possible on the analog input module:

- Voltage measurement
- Current measurement

Measurement Ranges

The measurement ranges are as follows:

- Voltage: $\pm 10\text{V}$
- Current: $\pm 20\text{mA}$

Measurement Ranges for 4-Wire Measuring Transducers

The measuring ranges for current measurement with 4-wire measuring transducers are as follows:

- $\pm 20\text{mA}$

7.3.1 Properties and Technical Data of the Analog Input Module

Properties

The analog input module has the following properties:

- 4 inputs
- Measured value resolution
 - 12 bits including sign
- Measurement type (selected by wiring):
 - Voltage
 - Current
- Measuring range selected per input
- Non-floating

Terminal Diagram

Figure 7-7 shows the terminal diagram of the analog inputs

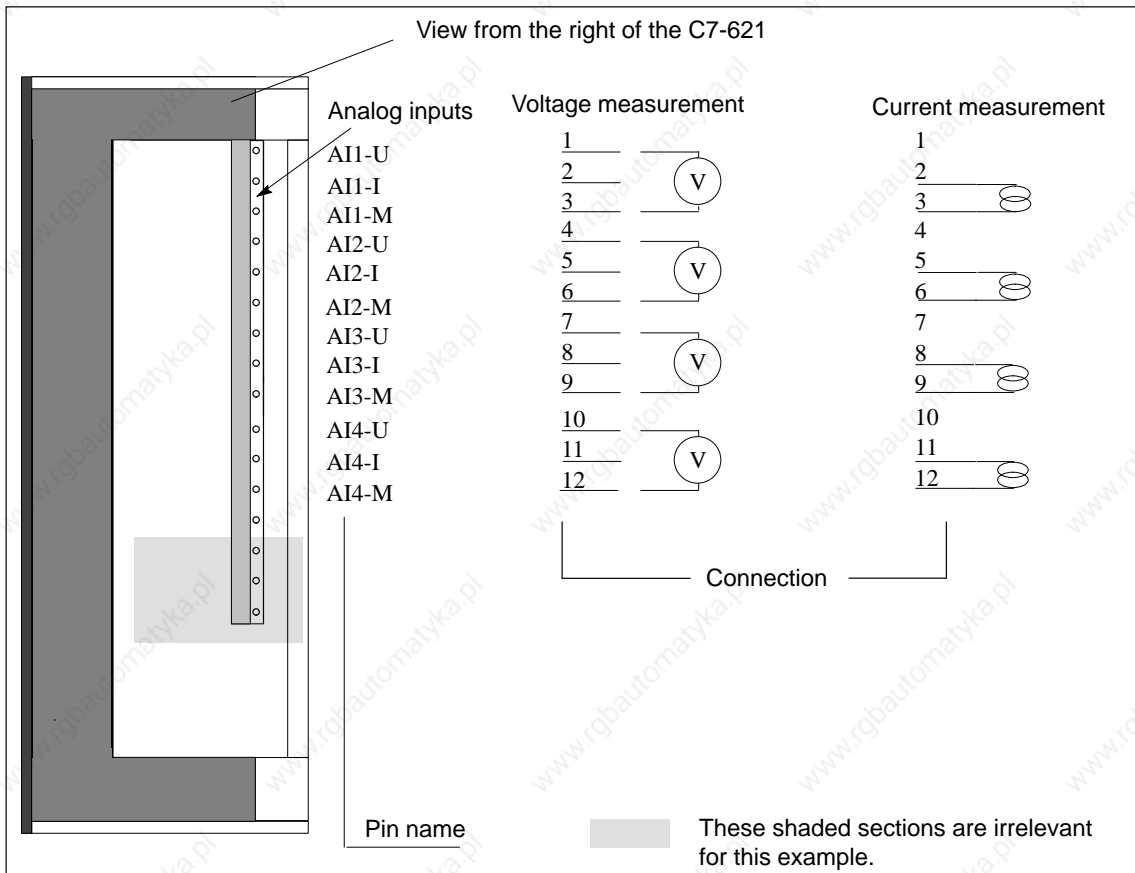

Figure 7-7 Terminal Diagram of the Analog Inputs

Analog Addresses

For more information about analog addresses, refer to Volume 2, Chapter 4.

Channels

Three pins are grouped together to form a channel.

Table 7-1 Channels of the Analog Input Module

Pin Name	Value	Channel
AI1-U	Voltage input	Channel 1 (AI1)
AI1-I	Current input	
AI1-M	Reference potential	
AI2-U	Voltage input	Channel 2 (AI2)
AI2-I	Current input	
AI2-M	Reference potential	
AI3-U	Voltage input	Channel 3 (AI3)
AI3-I	Current input	
AI3-M	Reference potential	
AI4-U	Voltage input	Channel 4 (AI4)
AI4-I	Current input	
AI4-M	Reference potential	

Connection to an Analog Input

Only an analog sensor can be connected to an analog input channel.

Voltage Measurement

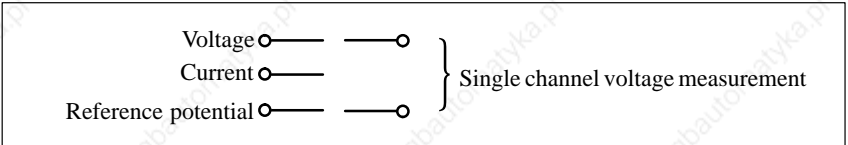

Figure 7-8 Connection of a Channel for Voltage Measurement

Current Measurement

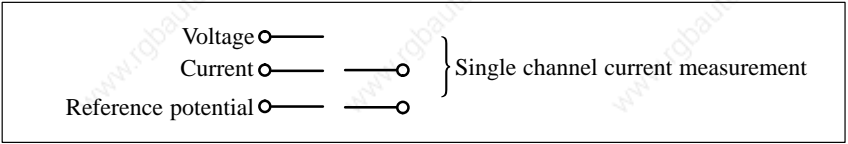

Figure 7-9 Connection of a Channel for Current Measurement

Analog Input

The following table contains the technical data of the analog inputs of the C7 CPU.

Module-Specific Data		Noise Suppression, Error Limits, continued	
Number of inputs	4	Basic error limit (operational limit at 25 °C relative to input range)	
Cable length		• Voltage input	± 0.9 %
• Shielded	max. 100 m	• Current input	± 0.8 %
Voltages, Currents, Potentials		Temperature error (relative to input range)	± 0.01 %/K
Permitted potential difference		Linearity error (relative to input range)	± 0.06 %
• Between inputs and M_{ANA} (U_{CM})	DC 1.0 V	Reproducibility accuracy (in settled state at 25 °C, relative to input range)	± 0.06 %
Analog Value Formation		Status, Interrupts; Diagnostics	
Measuring principle	Instantaneous value encoding (successive approximation)	Interrupts	none
Conversion time/resolution (per channel)		Diagnostic functions	none
• Base conversion time	100 µs	Data for Selecting a Sensor	
• Resolution (including overflow range)	11 bits + sign	Input ranges (rated values)/input resistance	
Noise Suppression, Error Limits		• Voltage	± 10 V/50 kΩ
Noise voltage suppression		• Current	± 20 mA/105.5 Ω
• Common mode voltage ($U_{CM} < 1.0$ V)	> 40 dB	Permitted input voltage for voltage input (destruction limit)	max. 30 V permanent; 38 V for max. 1 s (pulse duty factor 1:20)
Crosstalk between inputs	> 60 dB	Permitted input current for current input (destruction limit)	34 mA
Error limit (in the entire temperature range related to the input range)		Connection of sensors	
• Voltage input	± 1.0 %	• for voltage measurement	possible
• Current input	± 1.0 %	• for current measurement	
		as 2-wire transducer	not possible
		as 4-wire transducer	possible

7.4 Analog Output

Contents

This section describes the following:

- The properties of analog output
- The technical data of the analog output module

You will learn the following

- How to install and start up an analog output module
- Which ranges are provided by the analog output module
- The technical data for the analog output module

Properties

The analog output module has the following properties:

- 1 Output
- The output can be selected as:
 - Voltage output
 - Current output
- Resolution 12 bits including sign

Terminal Diagram

Figure 7-10 shows the terminal diagram of the analog output module.

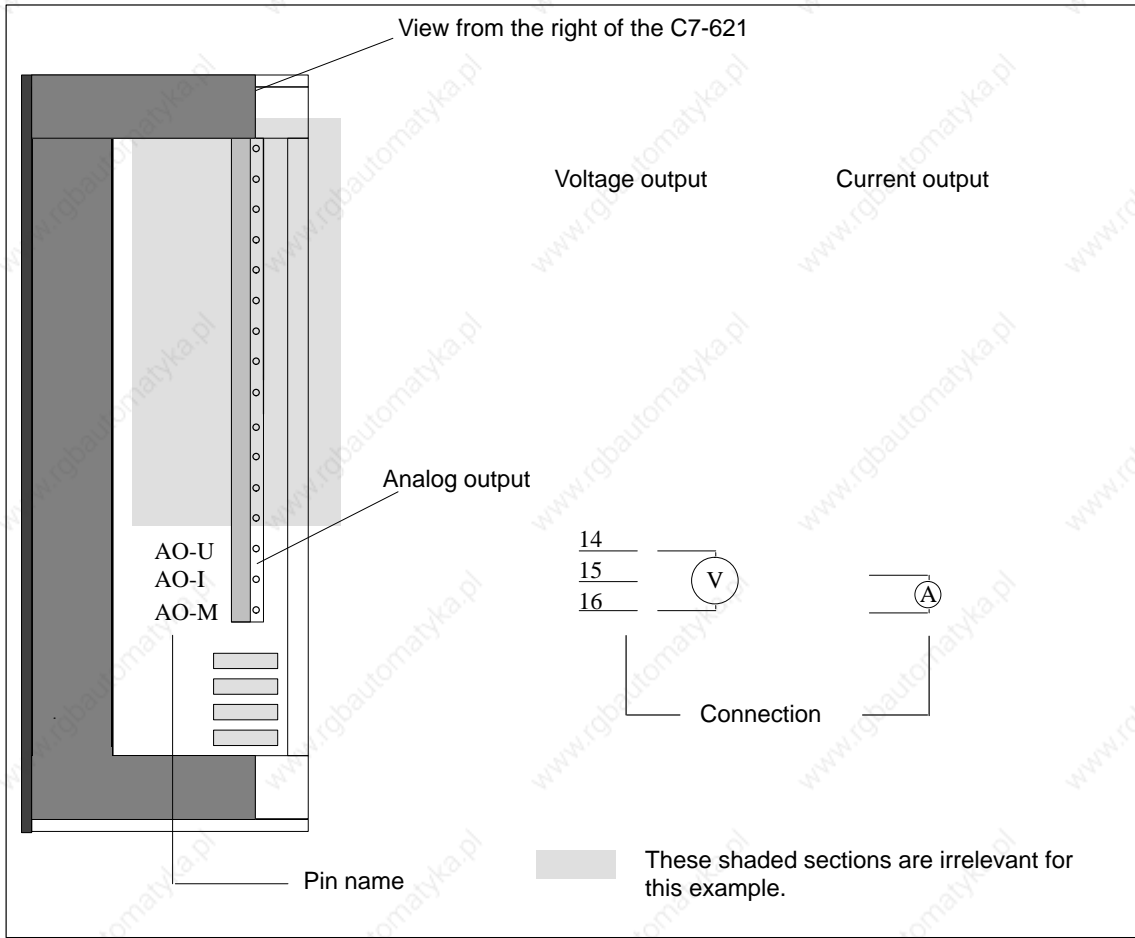

Figure 7-10 Terminal Diagram of the Analog Outputs

Analog Output

The following table contains the technical data of the analog output of the C7 CPU.

Module-Specific Data		Data for Selecting an Actuator	
Number of outputs	1	Output ranges (rated values)	
Cable length		• Voltage	$\pm 10\text{ V}$
• shielded	max. 100 m	• Current	$\pm 20\text{ mA}$
Analog Value Formation		Load resistance	
Resolution (including overflow)	11 bits + sign	• For voltage output	min. 2.0 k Ω
Conversion time	40 μs	Capacitive load	max. 0.1 μF
Settling time		• For current output	max. 300 Ω
• For ohmic load	0.6 ms	Inductive load	max. 0.1 mH
• For capacitive load	1.0 ms	Voltage output	
• For inductive load	0.5 ms	• Short circuit protection	yes
Substitute values applied	no	• Short circuit current	max. 40 mA
Noise Suppression, Error Limits		Current output	
Error limits (in the entire temperature range related to the output area)		• Idle voltage	max. 16 V
• Voltage output	$\pm 1.0\%$	Immunity limit against externally applied voltages/currents	
• Current output	$\pm 1.0\%$	• Voltages at output against M_{ANA}	max. $\pm 15\text{ V}$ permanent; $\pm 15\text{ V}$ for max. 1 s (pulse duty factor 1:20)
Error limit (error limit at 25 °C, related to the output area)		• Current	max. 30 mA
• Voltage output	$\pm 0.8\%$	Connection of actuators	
• Current output	$\pm 0.9\%$	• For voltage output	
Temperature error (related to output range)	$\pm 0.01\%/K$	2-wire connection	Possible
Linearity error (related to output range)	$\pm 0.06\%$	4-wire connection	Not possible
Reproducibility accuracy (in settled state at 25 °C, related to output range)	$\pm 0.05\%$	• For current output	
Output ripple: Range 0 to 50 kHz (related to output range)	$\pm 0.05\%$	2-wire connection	Possible
Status, Interrupts, Diagnostics			
Interrupts	none		
Diagnostic functions	none		

Maintenance

8

Replacing the C7

The C7 is not designed for field repair. A defective C7 must therefore be replaced.

Requirements

To replace a C7, the following requirements must be met:

Hardware

- Programming device/PC with MPI interface
- Suitable connecting cable

Development tools

- STEP 7
- ProTool or ProTool/Lite

User software (stored outside the C7)

- User configuration
- User control program (when data from the C7 CPU can no longer be read)

Removal

Follow the steps outlined below:

- The C7 is removed in the reverse order from that in which it was installed.
- Connect a programming device/PC to the MPI interface.
- Save the user program from the C7-CPU on a programming device/PC using STEP 7.
If the C7-CPU is defective and the user program can no longer be read, remove the C7 without attempting to back up the data.
- The configuration loaded on the C7 cannot be read. This must be available on a programming device or PC.

Installation

As soon as you have a new C7 available, install it as follows:

1. Mechanical and electrical installation is as described in the manual.
2. Connect a programming device/PC to the MPI interface. Set the highest MPI address.
3. Reset the C7 memory as described.
4. Transfer the previously saved user program from the programming device/PC with the corresponding data to the C7-CPU (using STEP 7).
5. Download your configuration to the C7 using ProTool/Lite.
6. Start the user program.

General Technical Specifications

A

What are General Technical Specifications?

This chapter lists the general technical specifications of the C7.

These general technical specifications include the standards with which the C7 complies, the test values that it meets and the test criteria with which the C7 was tested.

Chapter Overview

Section	Description	Page
A.1	Technical Specifications	A-2
A.2	Notes on the CE Approval	A-5
A.3	Notes for Manufacturers of Machines	A-7

A.1 Technical Specifications

The table contains the technical specifications of the entire unit. The data for the I/Os can be found in the relevant chapters.

Table A-1 Technical Specifications of the C7

Characteristic	Technical Specifications
C7-621 / C7-621 ASi	
Order number	C7-621: 6ES7621-1AD00-0AE3 C7-621 ASi: 6ES7621-6BD00-0AE3
Dimensions: C7 Installation dimensions	168 x 120 x 70 mm (H x W x D) 159 x 110 mm
Weight	C7-621: 1350g C7-621 AS-i: 1390g
Display C7-621 and C7-621 ASi	STN-LC display/ 2 lines of 20 characters each. 5 mm character height/ LED backlit
Keypad	Sealed keypad with metal domes C7-621: 23 keys
P bus (C7-621)	Interface to S7-300 modules
MPI interface	Standard MPI interface
C7 OP	
Flash memory (configuration memory)	C7-621: 128 Kbytes C7-621 AS-i: 128 Kbytes
C7-621 ASi CP	
Bus cycle time	5 ms with 31 slaves
Connection of the AS-i cable	Current load between terminals Ai+ and Ai+ maximum 4A
ASi CP current consumption	max. 100 mA
ASi CP supply voltage from the ASi cable	According to the AS-i specification
C7 Power Supply	
Supply voltage (U_N)	24 V DC (20.4 to 30.2 V.DC safety extra low voltage, SELV) the C7-621 and C7-621 ASi do not have protection against high-energy surge pulses in the μ s range. For details of protection, please refer to the manual /70/ Chapter 4.
<ul style="list-style-type: none"> Protected against reverse-polarity voltage Voltage dip (buffered) 	yes ≤ 20 ms
Current consumption (I_N)	1000mA max.
Safety	
Standards	DIN EN 61131-2 $\hat{=}$ IEC 1131-2

Table A-1 Technical Specifications of the C7, continued

Characteristic	Technical Specifications
Foreign body and water protection <ul style="list-style-type: none"> • Device front panel • Device housing 	IP 65 complying with IEC 529 IP 20 complying with IEC 529
Electromagnetic Compatibility (EMC)	
Emitted interference Limit value class C7-621 Limit value class C7-621 ASi	B compl. with EN55022 \cong CISPR 22 B compl. with EN55022 \cong CISPR 11
Conducted interference on DC voltage supply lines	$\pm 2\text{kV}$ (complying with IEC 801-4/IEC 1000-4-4; burst) $\pm 1\text{kV}$ (complying with IEC 801-5/IEC 1000-4-5; μs pulse /line to line)* $\pm 2\text{kV}$ (complying with IEC 801-5/IEC 1000-4-5; μs pulse / line to ground)* *) With protection element KT type AD 24 V from firm of Dehn
Noise immunity on signal lines	$\pm 2\text{kV}$ (complying with IEC 801-4/IEC 1000-4-4; burst)
Noise immunity against discharge C7-621	$\pm 6\text{kV}$, discharge on contact (complying with IEC 801-2/IEC 1000-4-2; ESD) $\pm 8\text{kV}$, atmospheric discharge (complying with IEC 801-2/IEC 1000-4-2; ESD)
Noise immunity against discharge C7-621 ASi	$\pm 4\text{kV}$, discharge on contact (complying with IEC 801-2/IEC 1000-4-2; ESD) $\pm 8\text{kV}$, atmospheric discharge (complying with IEC 801-2/IEC 1000-4-2; ESD)
Immunity to high-frequency radiation	10V, with 80% amplitude modulation with 1 kHz, 10kHz to 80MHz (complying with EN 50 141) 10V/m, with 80% amplitude modulation with 1 kHz, 80kHz-1GHz (complying with EN 50 140) 10V/m, pulse modulated 50 % c.d.f with 900 MHz (complying with EN 50 140),
Climatic Conditions	
Temperature Operation Storage/transport	Tested in compliance with DIN IEC 68-2-1, DIN IEC 68-2-2 $\pm 0^\circ\text{C}$ to $+45^\circ\text{C}$ installation at angle of 45° $\pm 0^\circ\text{C}$ to $+50^\circ\text{C}$ vertical installation Note: • At 45°C and horizontal installation, the legibility of the display is restricted. -20°C to $+70^\circ\text{C}$
Relative humidity Operation Storage/transport	Tested in compliance with DIN IEC 68-2-3 5% to 95% at 25°C (no condensation) 5% to 95% at 25°C (no condensation)
Atmospheric pressure Operation Storage/transport	1080-795 hPa (\cong -1000m to +2000m) 1080-660 hPa (\cong -1000m to +3500m)

Table A-1 Technical Specifications of the C7, continued

Characteristic	Technical Specifications
Mechanical Environmental Conditions	
Vibration Operation	Tested in compliance with DIN IEC 68-2-6 10 to 58 Hz, amplitude 0.075 58 to 500 Hz, acceleration 9.8m/s ²
Storage/transport	5 to 9 Hz, amplitude 3.5mm 9 to 500 Hz, acceleration 9.8 m/s
Shock Operation Storage/transport	Tested in compliance with DIN IEC 68-2-29 Semi-sinusoidal: 100m/s ² (10 g), 16 ms, 100 shocks 250 m/s ² (25 g), 6 ms, 1000 shocks
Resistance to fire hazards: Connector strips Connector strips in housing	V2 V0

24 V DC Power Supply

The entire 24 V DC power supply for the C7-621 and C7-621 ASi (operating voltage, load voltage, relay power supply etc.) must be provided as a safety extra-low voltage (SELV).



Warning

Danger of personal injury and damage to equipment.

If you do not implement the 24 V DC power supply for the C7-621 or C7-621 ASi correctly, this may result in damage to components of your automation system and to personal injury.

Use only safety extra-low voltage (SELV) for the 24 V DC power supply to your C7-621 or C7-621 ASi.

Relevant for the USA and Canada

If the device has one of the follow labels, the corresponding approval has been obtained:



Underwriters Laboratories (UL) complying with the UL 508 standard



UL Recognition Mark



Canadian Standard Association (CSA) complying with C 22.2. No 142 standard



APPROVED

FM-Standards No. 3611, 3600, 3810 APPROVED for use in Class I, Division 2, Group A, B, C, D indoor hazardous locations.

A.2 Notes on the CE Approval

CE Approval



SIMATIC products meet the requirements of the following EU directives.

EMC Directive

Our products meet the requirements of the EU Directive 89/336/EEC “Electromagnetic Compatibility”.

Area of Application

The CE approval for the C7-621 and C7-621 ASi compact units is as follows:

Area of Application	Requirements for	
	Noise Emission	Noise Immunity
Industrial and office area	EN 50081-2: 1993	EN 50082-2: 1995
Domestic area, business and trade area and small plants	EN 50081-1: 1992	EN 50082-1: 1992

Conformity Declaration

The EU conformity declarations are kept according to the EU directives listed above for the authorities responsible at the following address:

Siemens Aktiengesellschaft
 Bereich Automatisierungstechnik
 AUT 125
 Postfach 1963
 D-92209 Amberg

Installation Instructions

The installation guidelines and safety instructions described in the manual must be adhered to when installing and operating the devices.

Recycling and Disposal

The SIMATIC C7-621 is an environmentally friendly product.

The SIMATIC C7-621 has the following features in terms of the environment:

- Despite its high degree of flame resistance, the plastic housing is halogen free.
- The unit is labeled using lasers (in other words no plates or labels)
- The plastic materials are marked according to DIN 54840
- The small dimensions of the unit mean that less material is used, less components due to integration in ASICs

Due to its low levels of toxic materials, the SIMATIC C7-621 is suitable for recycling.

For more information about recycling and disposal of your old SIMATIC unit, contact the following department:

Siemens Aktiengesellschaft
Technische Dienstleistungen
ANL A 44 Kreislaufwirtschaft
Postfach 3240
D-91052 Erlangen
Germany
Telefon: 0 91 31/7-3 33 19
Telefax: 0 91 31/7-2 66 43

This Siemens department will advise you individually and provides a comprehensive and flexible disposal system for a fixed price. Following disposal, you receive reports about the dismantling of the units and the constituent materials.

A.3 Notes for Manufacturers of Machines

Introduction

The SIMATIC programmable controller system is not a machine as defined in the EU directive for machinery. There is therefore no declaration of conformity for SIMATIC within the frame work of the EU Machinery Directive 89/392/EEC.

EU Machinery Directive 89/392/EEC

The EU Machinery Directive 89/392/EEC regulates requirements relating to machinery. A machine is defined here as an assembly of interconnected parts or components (see also EN 292-1, Paragraph 3.1).

The SIMATIC PLC is part of the electrical equipment of a machine and must therefore be included by the machine manufacturer in the declaration of conformity procedure.

Electrical Equipment in Machinery Complying with EN 60204

The EN 60204-1 standard (safety of machinery, electrical equipment of machines, Part 1, specification for general requirements) applies for electrical equipment in machinery.

The table below is intended to help you with the declaration of conformity and to show which criteria apply to SIMATIC according to EN 60204-1 (as of June 1993).

EN 60204-1	Subject/Criterion	Remarks
Paragraph 4	General requirements	Requirements are met if the devices are mounted/installed in accordance with the installation guidelines. Please refer to the explanations on the previous pages.
Paragraph 11.2	Digital input/output interfaces	Requirements are met.
Paragraph 12.3	Programmable equipment	Requirements are met if the devices for protecting memory from changes by unauthorized persons are installed in locked cabinets.
Paragraph 20.4	Voltage tests	Requirements are met.

Guidelines for Handling Electrostatically Sensitive Devices (ESD)

B

Chapter Overview

Section	Description	Page
B.1	What is ESD?	B-2
B.2	Electrostatic Charging of Objects and Persons	B-3
B.3	General Protective Measures Against Electrostatic Discharge Damage	B-4
B.4	Taking Measurements and Working on ESD Modules	B-6
B.5	Packing Electrostatic Sensitive Devices	B-7

B.1 What is ESD?

Definition

All electronic modules are equipped with large-scale integrated ICs or components. Due to their design, these electronic elements are very sensitive to overvoltages and thus to any electrostatic discharge.

These **Electrostatic Sensitive Devices** are commonly referred to by the abbreviation **ESD**.

Electrostatic sensitive devices are labeled with the following symbol:

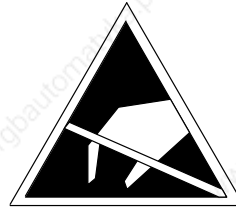

Caution

Electrostatic sensitive devices are subject to voltages that are far below the voltage values that can still be perceived by human beings. These voltages are present if you touch a component or module without previously being electrostatically discharged. In most cases, the damage caused by an over-voltage is not immediately noticeable and results in total damage only after a prolonged period of operation.

B.2 Electrostatic Charging of Objects and Persons

Electrostatic Charging

Every object with no conductive connection to the electrical potential of its surroundings can be charged electrostatically. In this way, voltages up to 15000 V can build up whereas minor changes, i.e. up to 100 V, are not relevant.

Examples:

- Plastic covers up to 5 000 V
- Plastic cups up to 5 000 V
- Plastic-bound books and notebooks up to 8 000 V
- Desoldering device with plastic parts up to 8 000 V
- Walking on plastic flooring up to 12 000 V
- Sitting of a padded chair up to 15 000 V
- Walking on a carpet (synthetic) up to 15 000 V

Limits for Perceiving Electrostatic Discharges

An electrostatic discharge is

- Perceptible from 3500 V
- Audible from 4500 V,
- Visible from 5000 V

A fraction of these voltages is capable of destroying or damaging electronic devices.

Carefully note and apply the protective measures described below to protect and prolong the life of your modules and components.

B.3 General Protective Measures Against Electrostatic Discharge Damage

Keep Plastics away

Keep plastics away from sensitive devices. Most plastic materials have a tendency to build up electrostatic charges easily.

Provide Sufficient Grounding

Make sure that the personnel, working surfaces and packaging are sufficiently grounded when handling electrostatically sensitive devices.

Avoid any Contact

If possible, avoid any contact with electrostatic sensitive devices. Hold modules without touching the pins of components or printed conductors. In this way, the discharged energy cannot affect the sensitive devices.

Additional Precautions for Modules without Housings

Note the following measures that have to be taken for modules that are not protected against accidental contact:

- Touch electrostatic sensitive devices only
 - if you wear a wristband complying with ESD specifications or
 - if you use special ESD footwear or ground straps when walking on an ESD floor.
- Persons working on electronic devices should first discharge their bodies by touching grounded metallic parts (e.g. bare metal parts of switchgear cabinets, water pipes, etc.).
- Protect the modules against contact with chargeable and highly insulating materials, such as plastic foils, insulating table tops or clothes made of artificial fibers.
- Place electrostatic sensitive devices only on conductive surfaces:
 - Tables with ESD surface
 - Conductive ESD foam plastic (ESD foam plastic is mostly colored black)
 - ESD bags
- Avoid direct contact of electrostatic sensitive devices with visual display units, monitors or TV sets (minimum distance to screen > 10 cm).

ESD Precautions

The following figure once again illustrates the precautions for handling electrostatically sensitive devices.

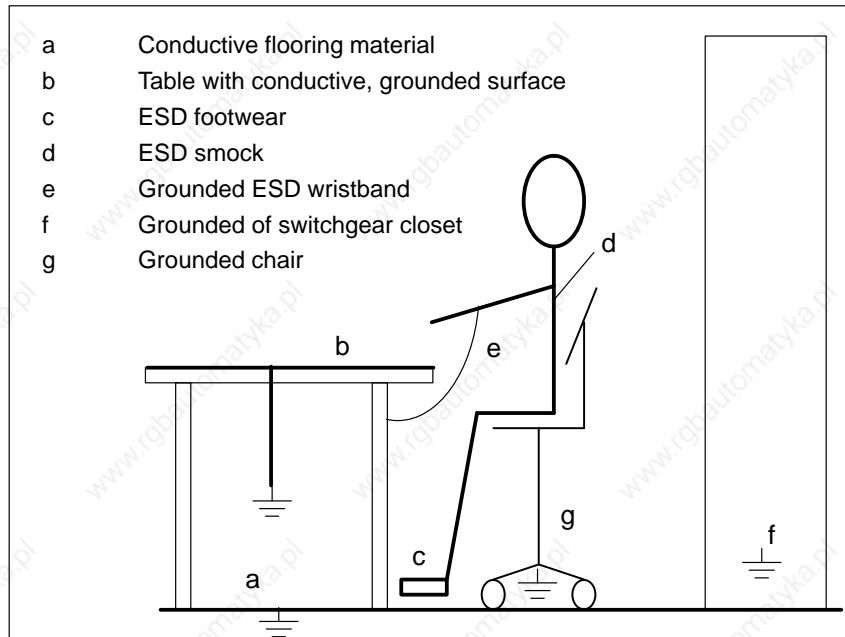

B.4 Taking Measurements and Working on ESD Modules

Use Grounded Measuring Devices Only

Measurements may be taken on electrostatic sensitive devices only if

- The measuring device is grounded (e.g. via protective conductor) or
- The tip of the isolated measuring device has previously been discharged (e.g. by briefly touching grounded metal parts).

B.5 Packing Electrostatic Sensitive Devices

Using Conductive Material for Packing Modules without Casing

Generally use conductive materials for packing modules without casing and components. You may also use metal-clad plastic boxes or metal cans.
Always store ESD modules in conductive packing material.

Cover Batteries

When packing modules incorporating batteries, cover the battery connections with insulating tape or insulating material to avoid short-circuiting of the battery. Remove the battery, if possible.

Safety of Electronic Controllers

C

Introduction

The information in this section is of a general nature and applies to all types of electronic controllers regardless of the manufacturer.

Reliability

The reliability of SIMATIC devices and components is kept as high as possible by comprehensive procedures during development and manufacturing.

These include the following:

- The use of high-quality components
- The worst-case dimensioning of all circuits
- Systematic and computer-controlled testing of all externally supplied components
- Burn-in of all large-scale integrated circuits (for example processors, memory, etc.)
- Measures for preventing static charge when handling MOS circuits
- Visual checks at all levels of manufacture
- In-circuit test of all modules, in other words computer-supported testing of all components and their interaction in the circuit
- Continuous tests at increased ambient temperatures over several days
- Thorough, computer-controlled final test
- Statistic evaluation of all returned products and immediate instigation of corrective measures
- Monitoring of the most important control components with online tests (parity monitoring in the RAM, watchdog for the CPU etc.).

These are basic measures that allow the vast majority of errors to be avoided or detected.

The Risks

Wherever injury to persons or damage to equipment can occur, special safety requirements must be met in the system. With such applications, there are special, system-specific regulations to be taken into account when designing the control system (for example VDE 0116 for furnaces).

With safety-oriented electronic controllers, the measures necessary to avoid or contain errors are based on the risk involved in the system. Where the potential dangers in a system are higher, the basic measures listed above are no longer adequate. Additional measures (for example redundancy, tests, checksums etc.) must therefore be implemented and certified for the controller (DIN VDE 0801). The fail-safe programmable controller S5-95F was tested by the TÜV, BIA and G EM III and has several certificates. This along with the fail-safe programmable controller S5-115F is suitable for controlling and monitoring areas where safety is a prime consideration.

Division into Safety and Non-Safety Areas

In almost all systems and plants, there are components that are responsible for safety (for example emergency stop switches, protective screens, two-hand switches). To avoid having to view the entire control system from a safety point of view, a control system is normally divided into a **safety** and a **non-safety** area. In the non-safety area, there are no particular requirements in terms of safety, since failure of the electronics does not affect the safety of the plant or process. In the safety area, only controllers or circuits can be used that meet the relevant safety regulations.

Areas are normally divided as follows:

1. For controls with few safety requirements (for example machine controls)

The conventional programmable controller handles machine control itself, parts where greater safety is required are controlled by the fail-safe mini PLC S5-95F.

2. For controls with clearly delineated safety areas (for example chemical plants, cable cars)

The non-safety area is once again implemented using conventional programmable controllers, the safety areas are controlled by tested fail-safe controllers (S5-115F or several S5-95Fs).

The entire plant is implemented using a fail-safe control concept.

3. For controllers where safety aspects are dominant (for example furnace systems)

The entire control system is fail-safe.

Important Note

Even when the planning of an electronic control system achieves a high degree of safety - for example with a multichannel configuration, the instructions in the manuals must nevertheless be followed carefully. Incorrect operation can lead to mechanisms intended to prevent serious situations being put out of action or to unforeseen dangers.

SIMATIC C7 and S7 References

D

References

- /70/ Manual: *S7-300 Programmable Controller, Hardware and Installation*
- /71/ Reference Manual: *S7-300, M7-300 Programmable Controllers Module Specifications*
- /72/ Instruction List: *S7-300 Programmable Controller CPU 312/314/315/315-DP*
- /231/ User Manual: *Standard Software for S7 and M7, STEP 7*
- /232/ Manual: *Statement List (STL) for S7-300 and S7-400, Programming*
- /233/ Manual: *Ladder Logic (LAD) for S7-300 and S7-400, Programming*
- /234/ Programming Manual: *System Software for S7-300 and S7-400 Program Design*
- /235/ Reference Manual: *System Software for S7-300 and S7-400 System and Standard Functions*
- /236/ Manual: *Function Block Diagram (FBD) for S7-300 and S7-400, Programming*
- /280/ Programming Manual: *System Software for M7-300 and M7-400, Program Design*

References for AS-i

/1/ AS-Interface. Das Aktuator-Sensor-Interface für die Automation
Werner Kriesel, O.W. Madelung, Carl Hanser Verlag München Wien 1994

/2/ AS-Interface Complete Specification

can be ordered from the AS-International Association e.V.

Address: AS-International Association e.V.
Geschäftsführung: Dr. Otto W. Madelung
Auf den Broich 4A
D - 51519 Odenthal
Germany

Tel.: +49 - 2174 - 40756
Fax.: +49 - 2174 - 41571

(AS-i technology is promoted by the AS-International Association e.V.)

/3/ SIMATIC NET Industrial Communications Networks
Catalog IK 10 “ 1997

The catalog can be ordered from any SIEMENS office.

Glossary

A

Analog Input/Output Module

Analog input/output modules convert analog process values (for example, input/output temperatures) into digital values that can be further processed by the C7 CPU or they convert digital values into analog manipulated variables.

B

Backup Memory

The backup memory guarantees backup of memory areas of the → C7-621 without a backup battery. A programmable number of timers, counters, memory bits and data bytes, the retentive timers, counters, memory bits and data bytes are backed up.

Baud Rate (transmission rate)

Speed at which data are transmitted (transmission rate in bps).

Bus

A bus is a transmission medium that connects two or more nodes with each other. Data transmission can be serial or parallel, over electrical conductors or fiber-optic cable.

C

C7-620

Name of the control system family of devices C7-62x

C7 AS-i

The C7 AS-i is the C7 component that controls communication with the actuators and sensors via the AS-interface. It also handles the internal C7 data exchange between the C7 AS-i and C7 CPU or C7 OP.

C7 CPU

The C7 CPU (central processing unit) contains the controller and arithmetic unit, memory, operating system and programming ports. The C7 CPU is independent of the → C7 OP. The C7 CPU has its own MPI address and is connected with the C7 OP via the MPI.

C7 I/Os

The C7 I/Os (→ signal module) form the interface between the process and the programmable controller. They provide digital input and output signals as well as analog input and output signals. The integral universal inputs have special functions in the C7 (interrupt/counter inputs).

C7 OP The C7 OP handles the OP functions of the C7. It is independent of the → C7 CPU and continues to operate if, for example, the C7 CPU changes to the STOP mode. The C7 OP has its own MPI address and is connected to the C7 CPU via the MPI.

Chassis Chassis ground includes all connected inactive parts of a device that cannot carry a hazardous voltage even in the event of a fault.

Communications Processor Communications processors are modules for point-to-point links and for LAN connections → CP.

Complete Restart When a C7 CPU is restarted (for example, after selection of one of the C7 CPU Operating Modes in the System Functions menu or after turning the power ON), the organization block OB100 (complete restart) is executed before cyclic program execution (OB1). During the complete restart, the process image of the inputs is read in and the STEP 7 user program is executed starting at the first instruction in OB1.

Configuration Assignment of modules to racks/slots and (for example, in the case of signal modules) addresses.

Configuration Memory The configuration memory is a flash memory containing the configuration data and is integrated in the C7 OP.

CP Communications processors (CPs) are intelligent modules with their own processor. They form an important group within the components of a programmable controller. A distinction is made between various types of communications processors depending on their tasks, for example, CPs for signaling and logging, for point-to-point connections, for the operator interface (COROS), for bus connections (SMATIC NET) and for diagnostics and mass storage applications.

Cyclic Interrupt A cyclic interrupt is generated periodically by the C7 CPU at selected intervals. It triggers execution of the assigned organization block.

D

Diagnostic Buffer The diagnostic buffer is a buffered memory area on the C7 CPU in which diagnostic events are entered in the order in which they occur.

Diagnostic Event Diagnostics events include errors in a digital function in the C7, system errors in the C7 caused, for example, by programming errors or operating mode transitions.

Diagnostic Functions The diagnostic functions cover the entire system diagnostics and include the detection, evaluation and signaling of errors/faults within the C7.

Diagnostic Interrupt Modules with diagnostic capability signal detected system errors to the → C7 CPU using diagnostics interrupts.

Diagnostics → Diagnostic functions, → System diagnostics

E

Equipotential Bonding Electrical connection (equipotential bonding conductor) that keeps the bodies of electrical devices to the same or approximately the same potential as extraneous conducting bodies to prevent interference or hazardous voltages arising between the bodies.

Error Display Error display is one of the possible responses of the operating system to runtime errors. The other possible responses are: Error response in the user program, STOP status of the C7 CPU.

F

Flash EPROM FEPRoMs correspond in their function to the electrically erasable EEPROMs but they can be erased much faster (FEPRoM = flash erasable programmable read-only memory)

The following data can be stored in a flash EPROM safe from power failure:

- The → user program
- The → parameters that determine the behavior of the → C7 CPU and the I/O functions of the C7.

Flash Memory → Flash EPROM

FM	An FM (function module) is a module that relieves the CPU of the S7-300 and S7-400 programmable controllers of time-critical or memory-intensive process signal handling tasks. FMs generally use the internal bus for high-speed data exchange with the CPU. Examples of FM applications include counting, positioning, closed-loop control.
Functional Ground	Grounding to ensure the intended purpose of the electrical devices. Functional grounding has the effect of short-circuiting interference voltages that would otherwise have unacceptable effects on the devices.
Ground	Conductive ground whose electrical potential at every point can be taken as zero. In the area of grounding electrodes, ground can have a potential different to zero. This is frequently referred to as "reference ground".
Grounding	To connect an electrically conductive part with the grounding electrode (one or more conductive parts that have very good contact to ground) via a grounding point.
H	
Hardware Interrupt	A hardware interrupt is triggered by interrupt-triggering modules as the result of certain events in the process. The hardware interrupt is signaled to the C7 CPU. Depending on the priority of the interrupt, the corresponding organization block is then executed.
I	
Information Function	The STEP 7 info functions allow you to display status information on the programming device via the connected C7 during the different phases of startup and during operation of a programmable controller.
Interface, Multipoint	→ MPI
Interrupt	The → operating system of the C7 CPU recognizes 10 different priority classes that control execution of the user program. Interrupts such as hardware interrupts belong to these priority classes. When an interrupt occurs, the operating system automatically calls an assigned organization block in which the user can program the desired response (for example, in an FB).

Isolated

In isolated input/output modules, the reference potentials of the control circuit and the load circuit are electrically isolated by, for example, optocouplers, relay contactors or transformers. Input/output circuits can be connected to common potential.

L

Load Memory

The load memory is a part of the C7 CPU. It contains objects (load objects) created by the programming device.

M

Memory Reset

When you clear the → C7 CPU, the following memories are deleted:

- The → work memory
- The read/write memory area of the → load memory
- The → system memory
- The → backup memory

and the user program is reloaded from the → flash memory.

When you clear the → C7 OP the following memories are deleted:

- The → work memory
- The → configuration memory

The C7 OP then no longer contains a user configuration.

MPI

The multipoint interface (MPI) is the programming device interface of SIMATIC S7. It allows simultaneous operation of several nodes (programming devices, text displays, operator panels) on one or several CPUs. The nodes on the MPI are connected to each other via a network. Each node is identified by a unique address (MPI address).

MPI Network

A network connects several C7s and/or S7-300s and further DTEs, such as programming devices, via a → connecting cable. Data are exchanged between the connected devices over the network.

N**Node Number**

The node number represents the “access address” of a C7 CPU, C7 OP or a programming or other intelligent I/O module when it communicates with other nodes over an → MPI network. The node number is assigned to the C7 CPU, C7 OP and programming device.

Non-isolated

In non-isolated input/output modules, the reference potentials of the control circuit and the load circuit are electrically connected.

O**Operating System of the C7-CPU**

The operating system of the C7 CPU organizes all functions and sequences of the C7 CPU that are not part of a special control task.

P**Parameter**

1. Variable of a STEP 7 logic block
2. Variable for setting the behavior of a module (one or more per module). Each module is supplied from the factory with a default setting that can be modified using the STEP 7 tool *S7 Configuration*.
There are → static parameters and → dynamic parameters.

Parameter Assignment

Parameter assignment refers to the setting of the behavior of a module.

Parameter, dynamic

In contrast to static parameters, dynamic module parameters can be modified during operation by calling an SFC in the user program, for example, limit values of an analog signal input module.

Parameter, static

In contrast to dynamic parameters, static module parameters cannot be modified by the user program. They can only be modified with the software tool *S7 Configuration*, for example input delay of a digital signal input module.

PG

→ Programming device

PLC

→ Programmable logic controller

Process Image

The signal states of the digital inputs and outputs are stored in the C7 CPU in a process image. There are two process images: the process image input table (PII) and the process image output table (PIQ).

The process image input table is read by the input modules before execution of the user program.

The process image output table is transferred to the output modules by the operating system at the end of the user program.

Programmable Logic Controller

Programmable controllers (PLCs) are electronic controllers whose function is stored as a program in the CPU. The design and wiring of these devices therefore does not depend on the controller function. The programmable controller has the structure of a computer; it consists of a CPU with memory, inputs and outputs and an internal bus system. The I/O and the programming language are designed specifically for the requirements of control engineering.

Programming Device

Programming devices are essentially personal computers that are compact and portable and suitable for use in industry. They are characterized by being equipped with special hardware and software for SIMATIC programmable controllers.

R

RAM

Random access memory is a read/write memory in which each memory cell can be addressed individually and can be changed. RAM memories are used as data memories and program memories.

Reference Ground

→ Ground

Reference Potential

Potential to which from which the voltages of the connected circuits are referred.

S

Scan Cycle Time

The scan cycle time is the time required by the → C7 to execute the → user program once.

Signal Module

Signal modules (C7 I/Os) form the interface between the process and the C7. There are digital input and output modules and analog input and output modules.

STEP 7	Programming software for creating user programs for SIMATIC 87 programmable controllers.
STEP 7 Tool	A STEP 7 tool is a tool of → STEP 7 tailored to a specific task.
Substitute Value	Substitute values are values that are output to the process or used in the user program in place of a process value in the event of a fault occurring in signal modules. The substitute values can be specified by the user (for example, keep old value).
System Diagnostics	System diagnostics includes the detection, evaluation and signaling of faults occurring within the programmable controller. Examples of such faults include program errors or module failures. System faults can be displayed via LEDs or using the S7 Information tool.
System Memory	The system memory is integrated on the CPU and implemented in the form of a RAM. The address areas (for example, timers, counters, memory bits) and the data areas required internally by the operating system (for example, buffers for communications) are stored in the system memory.
T	
Time-Delay Interrupt	The time-delay interrupt belongs to one of the priority classes in program execution on the C7 CPU. It is generated after expiry of a time started in the user program. The associated organization block is then executed.
Time-of-Day Interrupt	The time-of-day interrupt belongs to one of the priority classes in program execution on the C7 CPU. It is generated dependent on a specific date (or daily) and time (for example, 9:50 or hourly, or every minute). The associated organization block is then executed.
Tool	→ STEP 7 tool
Total Current	Sum of the currents of all output channels of a digital output module.
U	
Ungrounded	Without electrical connection to → ground

User Memory

The user memory contains the logic and data blocks of the user program. The user memory is integrated into the C7 CPU as a flash memory. However, the user program is executed in the → work memory of the C7 CPU.

User Program

The user program contains all the statements and declarations as well as data for signal processing by which a plant or process can be controlled. It is assigned to a programmable module (for example, C7 CPU, FM) and can be structured in smaller units (blocks).

V

Varistor

Voltage-dependent resistor

W

Work Memory

The work memory is a RAM in the → C7 620 that the processor uses to access the user program during program execution.

Index

368 connecting cable, 2-19
4-wire transducer
 connecting, 7-6
 measurement ranges, 7-10

A

Accessories, 2-2
Analog input, 7-10
 measurement ranges, 7-10
 properties, 7-11
 technical specifications, 7-11
 terminal diagram, 7-12
Analog output, 7-15
 terminal diagram, 7-16
Analog signal
 cable for, 7-7
 cables for, 7-2
AS-i
 cable, 5-3
 connecting, 5-2
AS-i connection, 2-11
AS-i power supply, 5-2
AS-i power supply unit, 5-2

B

Bus connector, 2-12, 3-10
 connecting to a module, 3-19
 installing the LAN cable, 3-15
 installing the PROFIBUS LAN cable, 3-17
 purpose, 3-12
 removing, 3-19
 setting the terminating resistor, 3-19
 terminating resistor, 3-5

C

C7
 installing, 2-3
 range of functions, 1-2, 1-3
C7 accessories, 2-2
C7 CPU, Glossary-2
 clock, 2-24
 memory reset, 2-21
C7 minimum clearance, 2-6
C7 OP, Glossary-3
 clock, 2-24
Cable, for analog signals, 7-2, 7-7
Cable lengths
 in an MPI network, 3-8
 maximum, 3-8
CE approval, A-5
Characteristic impedance. *Siehe* Abschlußwiderstand
Clock
 C7 CPU, 2-24
 C7 OP, 2-24
 master, 2-24
Coding key, 2-16
Communication, CPU–CPU, 3-3
Components
 for C7, 1-5
 for MPI network, 3-5, 3-10
Configuration memory, Glossary-3
Connecting cable, 1-5
CPU, 1-5
CPU–CPU communication, 3-3
CSA, A-4
Current measurement, 7-10
Current sensors, 7-2

D

- DI/DO status display, 6-7
 - explanation, 6-7
 - quitting, 6-7
 - selecting, 6-7
- Digital input, 2-8
- Digital output, 2-9
- Digital outputs, 6-4
 - points to note, 6-4

E

- EU directive, machines, A-7

F

- Flash EPROM, Glossary-4
- Flash memory, Glossary-4
- Four-wire transducer
 - connecting, 7-6
 - measurement range, 7-10
- FRCE, 2-23
- Functional ground, 2-7

G

- GD circle, 3-3
- Grounding, 2-13
- Grounding bar, installing, 2-15
- Grounding rail, 2-13
- Group error, CPU, 2-23

H

- Highest MPI address, 3-2

I

- IM 621 connection, 2-10
- IM 621 interface module, 1-5
- Input DC 24V, 2-7
- Installation, problem-free, 2-13
- Installation guidelines, 2-13
- Installing a LAN cable
 - with bus connector order no. 6ES7 ..., 3-15
 - with PROFIBUS bus connector, 3-14
- Installing C7, 2-3
- Interference signals, 2-13

K

- Keying connectors, 2-16

M

- Machines, with SIMATIC, A-7
- Male and female connectors, view, 2-7
- Manufacturers of machines, A-7
- Master clock, 2-24
- Measurement ranges, analog input, 7-10
- Memory reset, C7 CPU, 2-21
- Minimum clearance, C7, 2-6
- MPI, 3-2
- MPI address, 3-2
 - highest, 3-2
 - of the C7, 3-3
 - recommendation, 3-5
 - rules, 3-3
- MPI interface, pinout, 2-7
- MPI network
 - cable lengths, 3-8
 - components, 3-5, 3-10
 - configuration rules, 3-4
 - connecting a programming device, 4-2, 4-3
 - example of configuration, 3-7
 - tap lines, 3-8

N

- Network components, 3-10
- Node, 3-2
 - number of, 3-2

O

- OP, 1-5

P

- P bus, 2-18
- P bus interface, 2-18
- PG cable, 1-5, 2-12
- Power supply unit, AS-i, 5-2
- Printer connection, 2-8
- Problem-free installation, 2-13
- PROFIBUS bus connector, 3-13
- PROFIBUS bus terminal, 2-12

PROFIBUS LAN cable, 2-12, 3-10

- cabling rules, 3-11
- characteristics, 3-10
- fitting a bus connector, 3-17
- installing, 3-14

Programming device, 1-6

- connected to MPI network with tap line, 4-5
- connecting to an MPI network, 4-2, 4-3
- for service, 4-4
- in an MPI network, 4-4
- ungrounded configuration, 4-6

R

Range of functions, C7, 1-2, 1-3

References, D-1

Remote segment, 3-8, 3-9

RS 485 repeater, 1-6, 3-10

- terminating resistor, 3-6
- using, 3-5

RUN, 2-23

Run-time meter, 2-25

S

S7-300 (CPU), 1-5

Securing post

- fitting, 2-4
- releasing, 2-5

Sensor, non-isolated, 7-3

Sensors, isolated, 7-2

SF, 2-23

Shared data, 3-3

Shield clip, 2-15

Shielding, 2-13

Signal modules, 1-5

Status display, 6-7

- DI/DO, 6-7

STOP, 2-23

System functions menu, quitting, 6-7

T

Tap line, 3-4, 3-8

Terminating resistor, 3-4, 3-5

- bus connector order no. 6ES7 ..., 3-19
- example, 3-6
- on bus connector, 3-5
- on RS 485 repeater, 3-6

Transmission rate, 3-2

U

UL, A-4

Ungrounded configuration, connecting a programming device, 4-6

V

Voltage measurement, 7-10

Voltage sensor, connecting, 7-5

Voltage sensors, 7-2

W

Wiring closet layout, 2-13

Siemens AG
AUT E 146

Östliche Rheinbrückenstr. 50
D-76181 Karlsruhe
Federal Republic of Germany

From:

Your Name: _____

Your Title: _____

Company Name: _____

Street: _____

City, Zip Code _____

Country: _____

Phone: _____

Please check any industry that applies to you:

- | | |
|--|---|
| <input type="checkbox"/> Automotive | <input type="checkbox"/> Pharmaceutical |
| <input type="checkbox"/> Chemical | <input type="checkbox"/> Plastic |
| <input type="checkbox"/> Electrical Machinery | <input type="checkbox"/> Pulp and Paper |
| <input type="checkbox"/> Food | <input type="checkbox"/> Textiles |
| <input type="checkbox"/> Instrument and Control | <input type="checkbox"/> Transportation |
| <input type="checkbox"/> Nonelectrical Machinery | <input type="checkbox"/> Other _____ |
| <input type="checkbox"/> Petrochemical | |

