

# Permanent Magnet D.C. Servomotors

**MT22**  
SERIES

**MT30**  
SERIES

**MT40**  
SERIES

**MT52**  
SERIES



## TECHNICAL DATA MANUAL

ISSUE 2



# SEM

controlled motor technology



# PERMANENT MAGNET DC SERVOMOTORS - DATA MANUAL **ISSUE 2**

---

CONTENTS	PAGE
<b>1</b> USER INFORMATION	2
<b>2</b> <b>MT22 TECHNICAL INFORMATION</b>	<b>4</b>
- Technical Data and Performance Curves	4 - 9
- Mechanical Detail	10
- Engineering Drawings	11 - 12
- Standard/optional features	13
<b>3</b> <b>MT30 TECHNICAL INFORMATION</b>	<b>14</b>
- Technical Data and Performance Curves	14 - 27
- Mechanical Detail	28
- Engineering Drawings	29 - 31
- Standard/optional features	32 - 33
<b>4</b> <b>MT40 TECHNICAL INFORMATION</b>	<b>34</b>
- Technical Data and Performance Curves	34 - 39
- Mechanical Detail	40
- Engineering Drawings	41 - 43
- Standard/optional features	44 - 45
<b>5</b> <b>MT52 TECHNICAL INFORMATION</b>	<b>46</b>
- Technical Data and Performance Curves	46 - 57
- Mechanical Detail	58
- Engineering Drawings	59 - 61
- Standard/optional features	62 - 63

# PERMANENT MAGNET DC SERVOMOTORS - USER INFORMATION

## E.C. DIRECTIVES

There are 3 main directives that effect applications incorporating servomotors.

### Machinery Directive 89/392/EEC

This directive applies to complete machines.

In accordance with the directive, SEM provides a Certificate of Incorporation which includes installation instructions and general service guidelines in different languages.

### Low Voltage Directive 73/23/EEC

This directive applies to electrical equipment for use with a DC voltage of 75V to 1500V and AC voltage of 50V to 1000V.

SEM DC servomotors in the ranges MT22, MT30, MT40 and MT52 conform to the EC directive.

A certificate of conformity is available from SEM sales on request.

### EMC Directive (Electro Magnetic Compatibility) 89/336/EEC.

This directive applies to products or appliances with an intrinsic function for the end user in which:

1. They contain electrical/electronic systems liable to cause an electro magnetic disturbance.
2. They contain electrical/electronic systems which may have their performance affected by an electromagnetic disturbance.

SEM can provide data sheets outlining the EMC characteristics of a standard SEM DC servomotor and giving advice on cable screening and other related subjects.

SEM will be pleased to discuss any EMC related problem encountered by customers incorporating SEM DC servomotors into such products or appliances which are governed by the EMC directive.

## GENERAL DESCRIPTION

This range of DC Servomotors has been specially designed to meet the application requirements of Machine Tools, Transfer Lines, Robotics and the like. They provide a high torque to inertia ratio, giving fast acceleration and rapid dynamic response. Our data sheets give the full specification.

The motors are suitable for most servo and variable speed applications and are compatible with most drives available. It must be remembered that all SEM data on its range of Servomotors assumes unity Form Factor (i.e. pure DC) and that derating of the motor may be necessary when supplied from a power source exceeding unity Form Factor.

SEM DC brushed servomotors are rated for the temperature rises specified in NEMA standard MG1 part 12.63.2.

### Receiving & Storage

On receipt the motors should be inspected. Any damage found should be reported immediately to SEM and the carrier.

The shaft and flange have been coated with a rust inhibitor; this can be removed with a suitable solvent.

If the motors are not to be put into service immediately they should be stored in a clean dry location, and should be run on a light load or no load prior to being put in service. This is to clean any possible filming that may occur due to oxidation on the commutators.

### Nameplate Information

When contacting SEM regarding a motor, the type and serial number should be quoted.

### Location/Accessibility

The motors should be installed such that they are readily accessible for routine inspection and maintenance.

### Environmental Protection

SEM Servomotors are protected against ingress of fluid and dust to the following degrees:-

The MT22 range is protected to IP65 (IP64 at drive end shaft seal).

The MT30, 40 and 52 ranges are protected to IP44/65 as standard, IP54 is available as an option. This increases to IP64/65 when

a shaft seal (option WO1) is fitted and the fixing boltholes are sealed. Blower ventilated motors are protected to the following degrees:- The MT30 blower ventilated range is protected to IP20. The MT40 and 52 blower ventilated ranges are protected to IP10.

### Mounting of Motors

Where a toothed belt drive is proposed the motors should be face or flange mounted to an angle bracket, or similar, as close as possible to the line of action of the drive. The motor pulley should be positioned as close as possible to the mounting face and the pulley diameter chosen to maintain dynamic shaft loading within the limits indicated on the loading graphs. Particular attention must be given to tensioning of drive belts, with reference to belt manufacturers instructions, so that unnecessarily high shaft loads are avoided on installation.

When a motor is close coupled to a reduction gearbox, it is strongly recommended that to withstand the reaction of high output torques, the complete unit is fitted to the final product by attachment at the gearbox, not by foot mounting the motor.

A foot mounting option is available on SEM servomotors but this should generally be restricted to in-line drives where high lateral moments can be avoided.

### Electrical Connections

A diagram plate is fitted under the terminal box lid. (Or attached to each motor in the case of motors fitted with an MS connector).

**IMPORTANT** - When the motor is to be used in a closed loop circuit, the polarity of the tacho relative to the rotation of the motor must be as diagram plate. Incorrect polarity could cause the motor to over-speed. Commutator flashover and field demagnetisation could occur.

Viewed from main shaft end:

ROTATION	MOTOR	TACHO
Clockwise	A1 Positive	T1 Positive
	A2 Negative	T2 Negative
Anti-Clockwise	A2 Positive	T2 Positive
	A1 Negative	T1 Negative

### Thermal Protection

MT30, 40 and 52. Servomotors have fitted as standard equipment a thermal protector to monitor temperature and protect the armature winding. The protector contacts are of the normally closed type and should be connected in such a manner as to shut down the motor controller when the contacts open.

Under continuous full Load conditions the motor body can be expected to reach a maximum temperature of 100C° before the trip operates. **IMPORTANT** - The protector can only be relied upon to sense over temperature produced by long term overload operation of the motor. As the motor has a large thermal mass, short duration high currents will not be sensed by the thermal overload and could result in damage to the motor. The overload is not capable of switching motor line currents and must be used only in the motor drive circuitry.

### Maintenance & Servicing

All routine maintenance can be carried out by the user, but it is recommended that, for major repairs and reconditioning, the motor be sent to an approved motor repair specialist or returned to SEM. If the motor is to be dismantled, any feedback package fitted to the rear shaft, the tachometer armature, and any electrical connections must be removed first.

### Brushes - Motor

It is recommended that the motor brushes in the commutator end housing be inspected for wear every 500 hours of operation or at intervals which are found satisfactory after a usage pattern has been established. The brushes, under normal usage, should give 4,000 hours of life on a unity form factor drive. When the brush has worn to 7mm it should be replaced. Only recommended spares obtainable from SEM should be fitted, as brush grade and spring

tension have been specially selected for the motors. Brushes should move freely in their holders and care should be taken to ensure that good contact is made between the brush tag and the brush holder. When inspecting for carbon brush wear, we recommend that any carbon brush dust is cleared from the motor by removal of **all** the brushes from their holders, and blowing clean, dry air into one of the brush holders.

**IMPORTANT** - It must be noted that commutation and brush wear progressively deteriorate as the commutation limit is approached. If required acceleration or deceleration results in operation regularly close to the limit brushlife will be considerably reduced.

### Commutator

The normal colour of the commutator is dark brown: do not remove this film unless commutator is in poor condition. Minor cleaning of the commutator can be carried out by removing one brush and inserting a glass fibre cleaning stick of brush cross sectional area, and rotating the armature; remove other brushes and blow out after cleaning.

### Permanent Magnet Field

The permanent magnets used in our Servomotors are made from a highly coercive ferrite material and are designed to withstand high demagnetising fields. The field will be demagnetised if a momentary current exceeds the peak current rating given on the data sheet. Special note should be made when using thyristor drives. The permanent magnet field is open circuit stabilised and the motor armature removal will not affect subsequent motor performance. On blower ventilated machines, despite the inlet filter, there may be a danger that metal particles and foreign matter may enter the air outlet holes by attraction of the permanent magnets. Care must be taken with ventilated machines. Should the magnets become demagnetised for any reason the machine must be returned to SEM for re-magnetising.

### Bearings

All Servomotors are fitted with single row radial ball bearings, double shielded and permanently lubricated and under normal conditions require no maintenance. If the commutator end bearing is to be removed, care should be taken so as not to damage or distort the rear shaft extension or shaft pin, as these must run to close tolerances.

### Tachometer

The tachometer fits over the main shaft and has a permanent magnet field. This device is a precision instrument and must be treated with care. Foreign matter must not be allowed to enter this area. The brushes and commutator should be maintained in the same manner as the motor parts. It is essential that the undercutting is maintained free from mica and copper swarf and the commutator surface is free of burrs to keep the ripple performance within tolerance. When re-assembling brush ring to motor, note alignment mark to retain correct orientation of parts for optimum performance.

### Holding Brake Options

A fail safe brake is available as a standard option. The brake is primarily a holding brake. For example:- to hold a vertical feed axis under a no voltage condition, however, it can also in some applications be used for emergency stopping. The brake is located in front of the armature, the stationary body is built into the drive end cover. The brake fitted is of the "Springset" fail to safe type. The brake should be connected so that when the motor is started the brake coil is energised, thus releasing the brake. Under normal operating conditions no maintenance is required other than making sure the armature and stationary plates are kept free from foreign matter. Ratings are as follows:-

Frame	Brake Holding Torque	Voltage (DC)	Power Consumed (Guide only)
MT22	2 Nm	24v (90v)	6.3 Watts (9 Watts)
MT30	5 Nm	24v (90v)	11 Watts (13 Watts)
MT40	18 Nm	24v (90v)	27 Watts (27 Watts)
MT52	18 Nm	24v (90v)	27 Watts (27 Watts)

Other voltages DC and AC can be ordered

### Blower Options

The motor of the blower type used by SEM is sealed for life and should require no maintenance under normal usage. The inlet filter should be cleaned at regular intervals, as a dirty filter would restrict the airflow through the servomotor, causing overheating. When dirty this filter can be regenerated by washing in warm water with added detergent and drying.

### Mechanical

It is recommended that a general inspection be made at regular intervals to check all bolts, nuts, couplings, etc. to make sure they have not worked loose, and thus prevent serious damage.

### End Cover Alignments

The proper orientation of the motor end cover to the motor body is necessary for optimum performance of the motor; an alignment mark should be scribed over end housing and adjacent shell before dismantling, so machine can be re-assembled with correct orientation.

The drive end cover is pinned to the shell. The developed torque of the motor is transmitted by the pins and associated friction between D.E. cover and shell.(Not applicable to MT22) The commutator end housing is not pinned, as under normal conditions no torque is transmitted.

### Recommended Stand By Replacement Parts List per motor.

MOTOR PART	MOTOR TYPE				
	MT22	MT30	MT40	MT52	DBMT52
Motor Brush	Qty 2	Qty 4	Qty 4	Qty 8	Qty 16
Brush Caps	2	4	4	8	16
Brush Cap Sealing Discs	2	4	4	8	16
Tacho Brush Ring Assembly complete with Brushes	1	1	1	1	1

Note: When ordering replacement parts the motor Serial No. stamped on Nameplate must be quoted, along with the Type No. so that proper selection of parts can be made.

### Fault Finding

Note: Trouble which at first appears to be with the motor may in many cases lie outside the motor

PROBLEM	POSSIBLE CAUSES
No Rotation at Motor Shaft	1 Check Fuses and Connections 2 Brushes Worn Past Limit 3 Motor Load Excessive 4 Motor Overload Open Circuit 5 Armature Open Circuit 6 Brake Failure on Motors Fitted with Brake
Excessive Brush Arcing	1 Motor Load Excessive 2 Armature Input Current or Voltage Excessive 3 Damaged Commutator 4 Motor Speed Exceeding Maximum 5 Incorrect Brush Grade 6 Incorrect Neutral Setting 7 Shorted/Earthed Armature
Over Speed	1 Armature Volts Over Limit 2 Wrong Connection Motor/Tacho 3 No Tacho Output 4 Field Demagnetised
Poor Tachometer Ripple	1 Tacho Brushes Not Seated 2 Incorrect Neutral Setting 3 Shorted Tachometer Armature 4 Rough Commutator Surface
Noise/Vibration	1 Loose Components/Through Bolt 2 Defective Bearings 3 Armature Incorrectly Balanced

# MT22D2 D.C. Servomotors

## Technical Data

Parameter	Unit	MT22D2-19	MT22D2-10	MT22D2-5
<b>GENERAL</b>				
Voltage Gradient No Load	Volts/1000RPM*	19	10	5
Max. Terminal Voltage	Volts	95	50	25
Max. Speed	RPM	5000	5000	5000
<b>Continuous Stall Torque TENV***</b>	<b>Nm</b>	<b>0.5</b>	<b>0.5</b>	<b>0.5</b>
	<b>lb - in</b>	<b>4.4</b>	<b>4.4</b>	<b>4.4</b>
(Size 300x300x12.5mm)	Nm	0.6	0.6	0.6
Cont Stall Torque when fitted to Heatsink ***				
(Size 12x12x0.5in)	lb - in	5.3	5.3	5.3
<b>Continuous Stall Current TENV***</b>	<b>Amps</b>	<b>2.8</b>	<b>5</b>	<b>10</b>
Armature Polar Moment of Inertia	Kgm <sup>2</sup>	0.00017	0.00017	0.00017
	lb - in Sec <sup>2</sup>	0.0015	0.0015	0.0015
<b>Torque Constant KT**</b>	<b>Nm/Amp*</b>	<b>0.18</b>	<b>0.10</b>	<b>0.05</b>
	<b>lb - in/Amp*</b>	<b>1.59</b>	<b>0.88</b>	<b>0.44</b>
Voltage Constant KV**	Volts Sec Rad <sup>-1</sup> *	0.18	0.10	0.05
Peak Stall Torque**	Nm	2.0	2.0	2.0
	lb - in	18	18	18
Current at Peak Torque**	Amps	11	21	43
Theoretical Acceleration at Peak Torque	Rad/Sec <sup>2</sup>	12000	12000	12000
<b>Winding</b>				
Armature Resistance Less Brushes**	Ohms*	3.5	1.0	0.28
Armature Inductance	Millihenrys*	14.1	4.0	1.12
Mechanical Time Constant**	Milliseconds	18.0	18.0	18.0
<b>Thermal</b>				
Insulation Class		F	F	F
Max. Ambient Temperature	°C	40	40	40
Thermal Time Constant	Minutes*	25	25	25
<b>Mechanical</b>				
Static Friction Torque	Nm	0.055	0.055	0.055
(Shaft Seal Lubricated)	lb - in	0.486	0.486	0.486
Motor Weight	Kg	2.7	2.7	2.7
	lb	5.9	5.9	5.9
<b>TACHOMETER</b>				
Voltage Gradient	Volts/1000RPM*	9.5	7	
	Volts Sec Rad <sup>-1</sup> *	0.095	0.067	
Ripple	Per Cent	1.0	1.0	
	Cycles/Rev	33	33	
Armature Resistance**	Ohms	90	65	
Armature Inductance	Millihenrys*	15	8	
Maximum Current	Amps	0.02	0.03	

\* Tolerance Plus or Minus 10%

\*\* At 25°C

\*\*\* At 40°C Ambient

■ **Motor Performance** data is on the basis of a pure D.C. i.e. unity system form factor supply. Appropriate performance derating is necessary when using a supply with a system form factor greater than unity.

■ **Commutation Curves** opposite and peak torque are based on the **peak value** of the current wave form. For a form factor greater than unity the maximum torque permitted will be lower than that detailed on the performance curves. **IMPORTANT** The commutation curves are based on a load inertia equal to the motor inertia. Advice should be taken in the event the load inertia is greater than the motor inertia.

● **Heatsink Ratings** Torque ratings shown in brackets (opposite top right) are correct for motors when fitted to a heatsink size (300mm x 300mm x 12mm)  
(12" x 12" x 0.5")

**STALL TORQUE 0.5Nm / 4.4lb-in**

**● (0.6Nm / 5.3lb-in)**

## Performance Curves

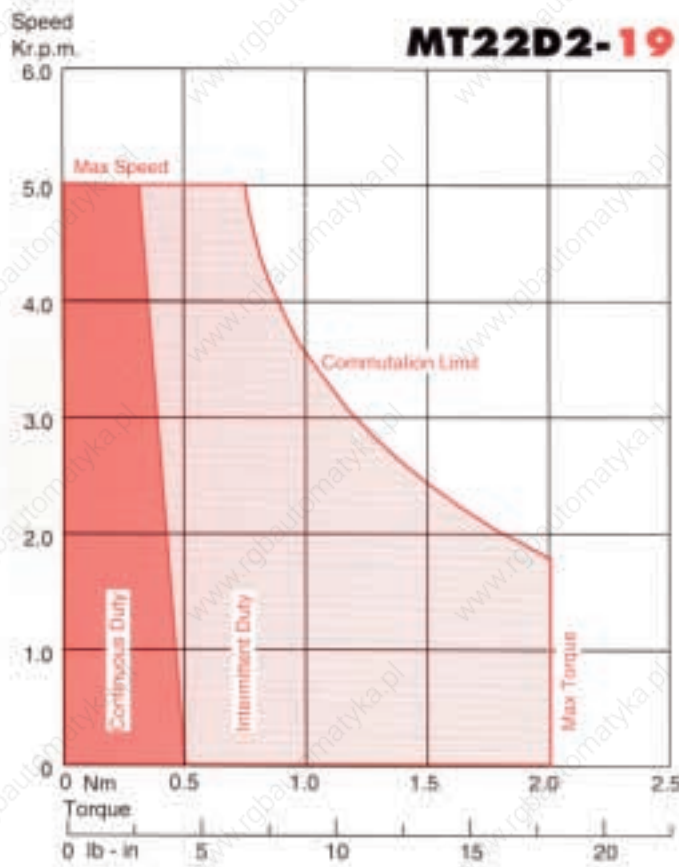
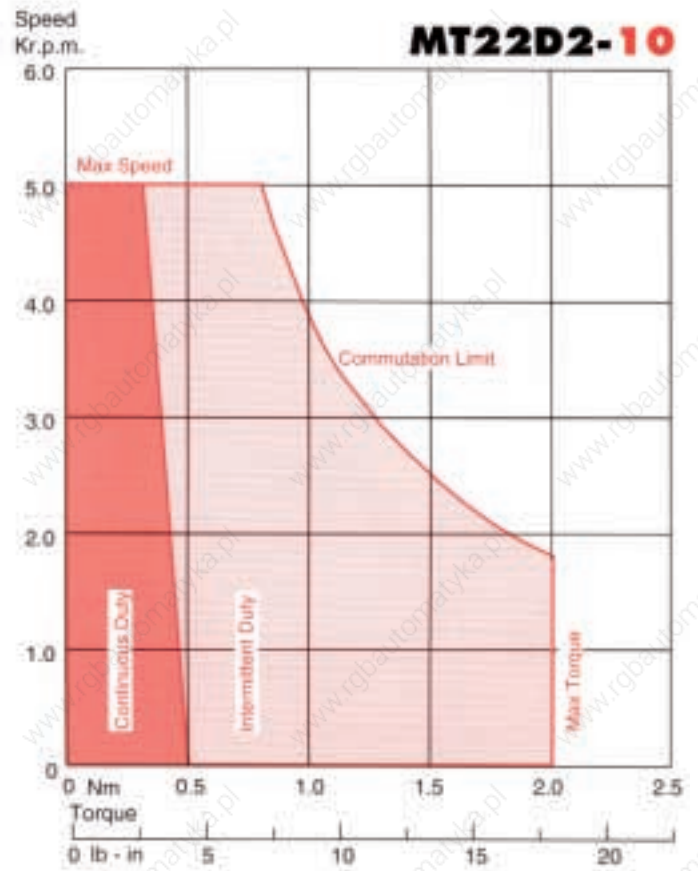
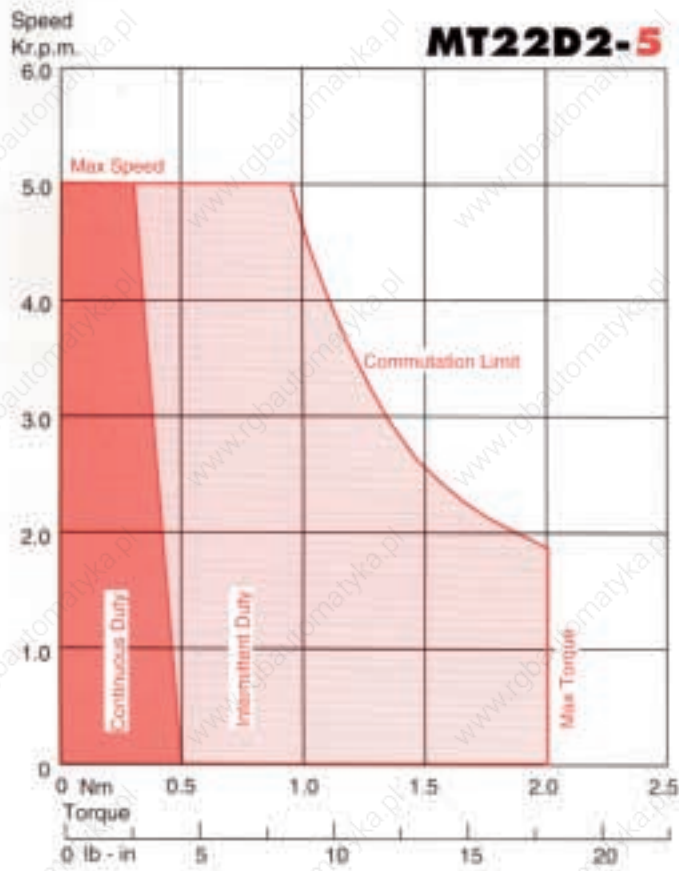

# MT22G2 D.C. Servomotors

## Technical Data

Parameter	Unit	MT22G2-19	MT22G2-10	MT22G2-5
<b>GENERAL</b>				
Voltage Gradient No Load	Volts/1000RPM*	19	10	5
Max. Terminal Voltage	Volts	95	50	25
Max. Speed	RPM	5000	5000	5000
<b>Continuous Stall Torque TENV***</b>	<b>Nm</b>	<b>0.7</b>	<b>0.7</b>	<b>0.7</b>
	<b>lb - in</b>	<b>6.2</b>	<b>6.2</b>	<b>6.2</b>
(Size 300x300x12.5mm)	Nm	0.8	0.8	0.8
Cont Stall Torque when fitted to Heatsink***				
(Size 12x12x0.5in)	lb - in	7.1	7.1	7.1
<b>Continuous Stall Current TENV***</b>	<b>Amps</b>	<b>3.9</b>	<b>7</b>	<b>14</b>
Armature Polar Moment of Inertia	Kgm <sup>2</sup>	0.00028	0.00028	0.00028
	lb - in Sec <sup>2</sup>	0.0024	0.0024	0.0024
<b>Torque Constant KT**</b>	<b>Nm/Amp*</b>	<b>0.18</b>	<b>0.10</b>	<b>0.05</b>
	<b>lb - in/Amp*</b>	<b>1.59</b>	<b>0.88</b>	<b>0.44</b>
Voltage Constant KV**	Volts Sec Rad <sup>-1*</sup>	0.18	0.10	0.05
Peak Stall Torque**	Nm	4.0	4.0	4.0
	lb - in	35.4	35.4	35.4
Current at Peak Torque**	Amps	22.0	42.0	84.0
Theoretical Acceleration at Peak Torque	Rad/Sec <sup>2</sup>	14000	14000	14000
<b>Winding</b>				
Armature Resistance Less Brushes**	Ohms*	2.5	0.63	0.16
Armature Inductance	Millihenrys*	8.2	2.1	0.5
Mechanical Time Constant**	Milliseconds	17.0	17.0	17.0
<b>Thermal</b>				
Insulation Class		F	F	F
Max. Ambient Temperature	°C	40	40	40
Thermal Time Constant	Minutes*	25	25	25
<b>Mechanical</b>				
Static Friction Torque	Nm	0.055	0.055	0.055
(Shaft Seal Lubricated)	lb - in	0.486	0.486	0.486
Motor Weight	Kg	3.3	3.3	3.3
	lb	7.3	7.3	7.3
<b>TACHOMETER</b>				
Voltage Gradient	Volts/1000RPM*	9.5	7	
	Volts Sec Rad <sup>-1*</sup>	0.095	0.067	
Ripple	Per Cent	1.0	1.0	
	Cycles/Rev	33	33	
Armature Resistance**	Ohms	90	65	
Armature Inductance	Millihenrys*	15	8	
Maximum Current	Amps	0.02	0.03	

- \* Tolerance Plus or Minus 10%
- \*\* At 25°C
- \*\*\* At 40°C Ambient

■ **Motor Performance** data is on the basis of a pure D.C. i.e. unity system form factor supply. Appropriate performance derating is necessary when using a supply with a system form factor greater than unity.

■ **Commutation Curves** opposite and peak torque are based on the **peak value** of the current wave form. For a form factor greater than unity the maximum torque permitted will be lower than that detailed on the performance curves. **IMPORTANT** The commutation curves are based on a load inertia equal to the motor inertia. Advice should be taken in the event the load inertia is greater than the motor inertia.

● **Heatsink Ratings** Torque ratings shown in brackets (opposite top right) are correct for motors when fitted to a heatsink size (300mm x 300mm x 12mm)  
(12" x 12" x 0.5")

**STALL TORQUE 0.7Nm / 6.2lb-in**

**● (0.8Nm / 7.1lb-in)**

## Performance Curves

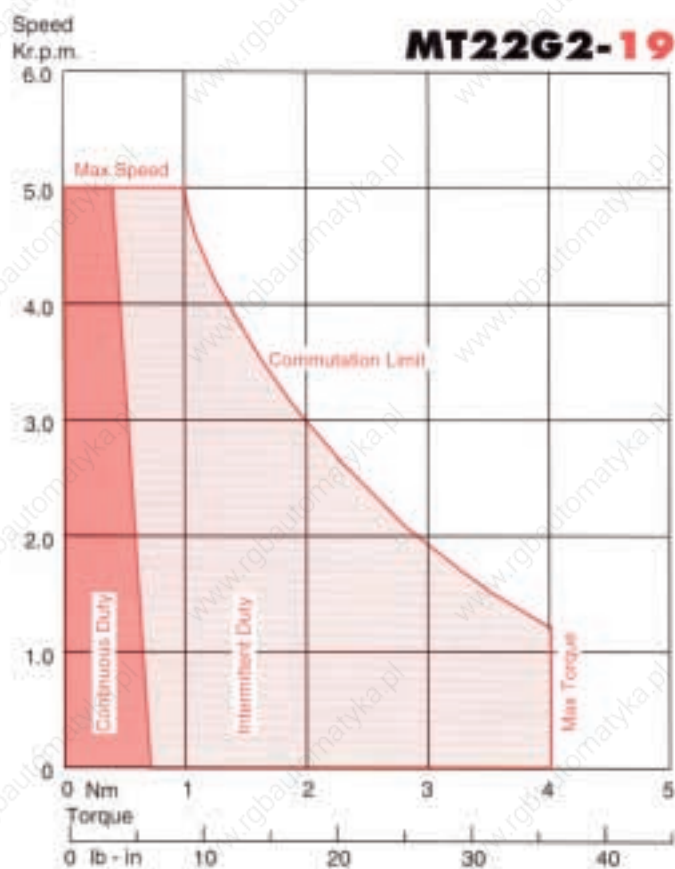
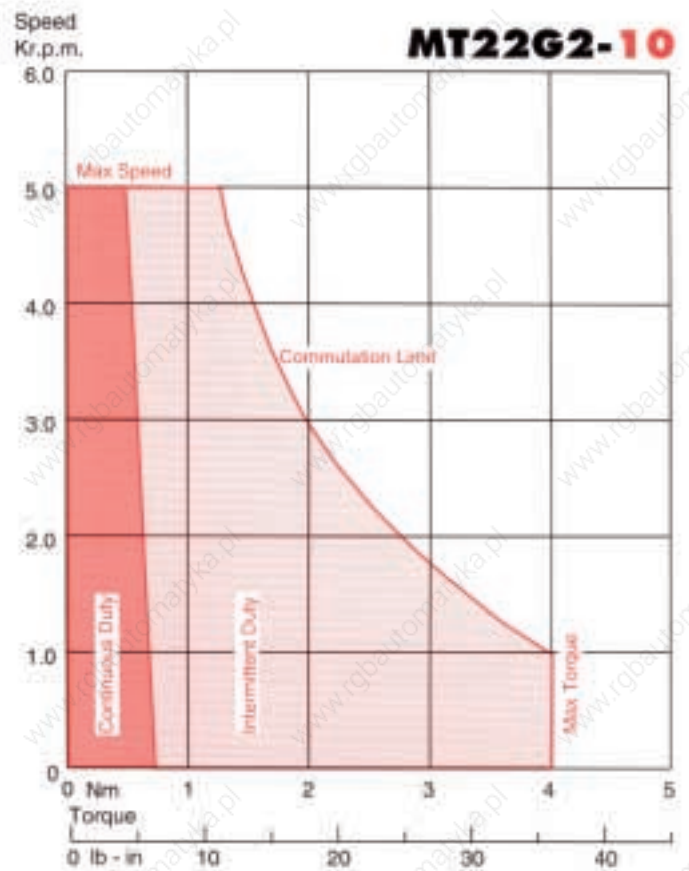
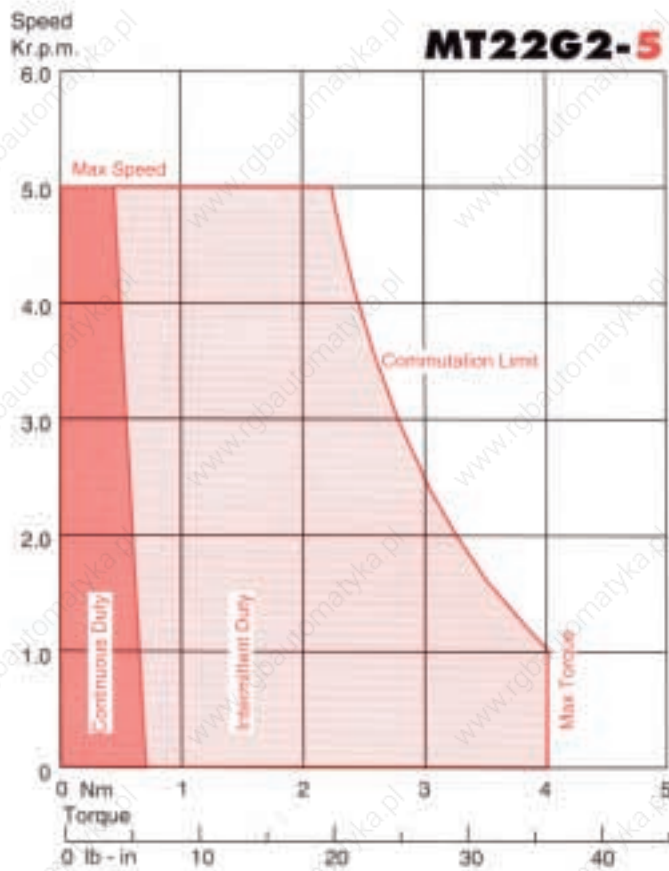

# MT22R2 D.C. Servomotors

## Technical Data

Parameter	Unit	MT22R2-24	MT22R2-19	MT22R2-12	MT22R2-10
<b>GENERAL</b>					
Voltage Gradient No Load	Volts/1000RPM*	24	19	12	10
Max. Terminal Voltage	Volts	120	95	60	50
Max. Speed	RPM	5000	5000	5000	5000
<b>Continuous Stall Torque TENV***</b>	<b>Nm</b>	<b>1.2</b>	<b>1.2</b>	<b>1.2</b>	<b>1.2</b>
	<b>lb - in</b>	<b>10.6</b>	<b>10.6</b>	<b>10.6</b>	<b>10.6</b>
(Size 300x300x12.5mm)	Nm	1.35	1.35	1.35	1.35
Cont Stall Torque when fitted to Heatsink***					
	(Size 12x12x0.5in)	lb - in	11.9	11.9	11.9
<b>Continuous Stall Current TENV***</b>	<b>Amps</b>	<b>5.2</b>	<b>6.7</b>	<b>10.9</b>	<b>12.0</b>
Armature Polar Moment of Inertia	Kgm <sup>2</sup>	0.0006	0.0006	0.0006	0.0006
	lb - in Sec <sup>2</sup>	0.00531	0.00531	0.00531	0.00531
<b>Torque Constant KT**</b>	<b>Nm/Amp*</b>	<b>0.23</b>	<b>0.18</b>	<b>0.11</b>	<b>0.10</b>
	<b>lb - in/Amp*</b>	<b>2.03</b>	<b>1.59</b>	<b>0.97</b>	<b>0.88</b>
Voltage Constant KV**	Volts Sec Rad <sup>-1*</sup>	0.23	0.18	0.11	0.10
Peak Stall Torque**	Nm	8.0	8.0	8.0	8.0
	lb - in	71.0	71.0	71.0	71.0
Current at Peak Torque**	Amps	35	44	70	84
Theoretical Acceleration at Peak Torque	Rad/Sec <sup>2</sup>	13,300	13,300	13,300	13,300
<b>Winding</b>					
Armature Resistance Less Brushes**	Ohms*	1.6	0.98	0.34	0.26
Armature Inductance	Millihenrys*	4.1	2.6	0.89	0.65
Mechanical Time Constant**	Milliseconds	16	16	16	16
<b>Thermal</b>					
Insulation Class		F	F	F	F
Max. Ambient Temperature	°C	40	40	40	40
Thermal Time Constant	Minutes*	25	25	25	25
<b>Mechanical</b>					
Static Friction Torque	Nm	0.055	0.055	0.055	0.055
	(Shaft Seal Lubricated)	lb - in	0.486	0.486	0.486
Motor Weight	Kg	5	5	5	5
	lb	11	11	11	11
<b>TACHOMETER</b>					
Voltage Gradient	Volts/1000RPM*	9.5		7	
	Volts Sec Rad <sup>-1*</sup>	0.09		0.067	
Ripple	Per Cent	1.0		1.0	
	Cycles/Rev	33		33	
Armature Resistance**	Ohms	90		65	
Armature Inductance	Millihenrys*	15		8	
Maximum Current	Amps	0.02		0.03	

\* Tolerance Plus or Minus 10%

\*\* At 25°C

\*\*\* At 40°C Ambient

■ **Motor Performance** data is on the basis of a pure D.C. i.e. unity system form factor supply. Appropriate performance derating is necessary when using a supply with a system form factor greater than unity.

■ **Commutation Curves** opposite and peak torque are based on the **peak value** of the current wave form. For a form factor greater than unity the maximum torque permitted will be lower than that detailed on the performance curves. **IMPORTANT** The commutation curves are based on a load inertia equal to the motor inertia. Advice should be taken in the event the load inertia is greater than the motor inertia.

● **Heatsink Ratings** Torque ratings shown in brackets (opposite top right) are correct for motors when fitted to a heatsink size (300mm x 300mm x 12mm)  
(12" x 12" x 0.5")

**STALL TORQUE 1.2Nm / 10.6lb-in**

**● (1.35Nm / 11.9lb-in)**

## Performance Curves

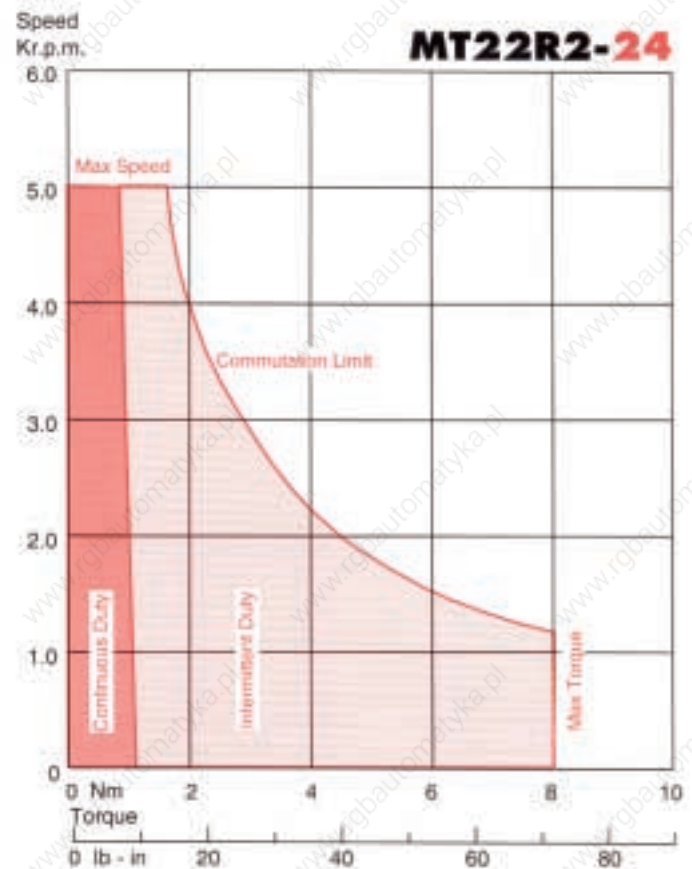
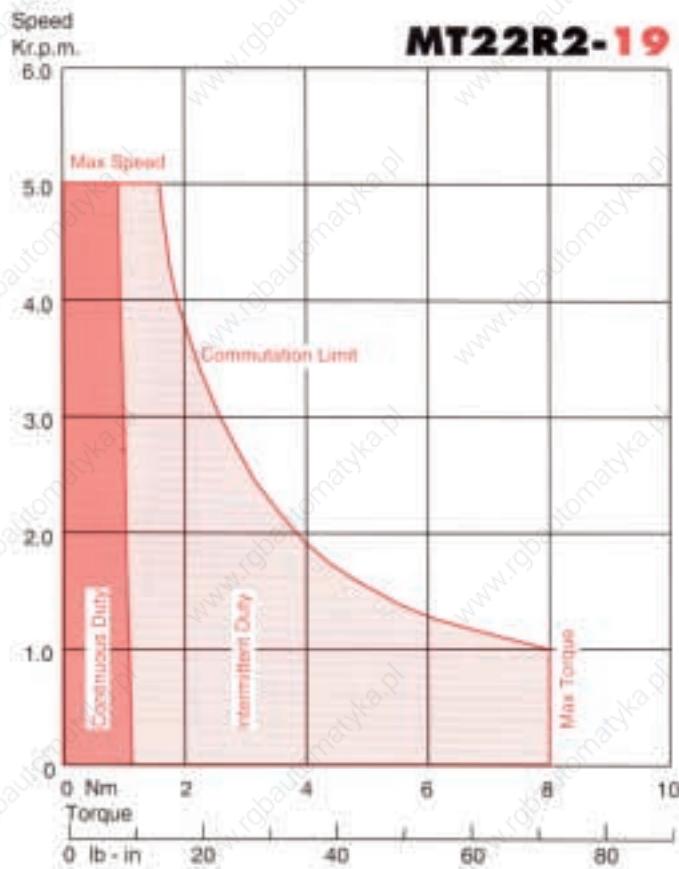
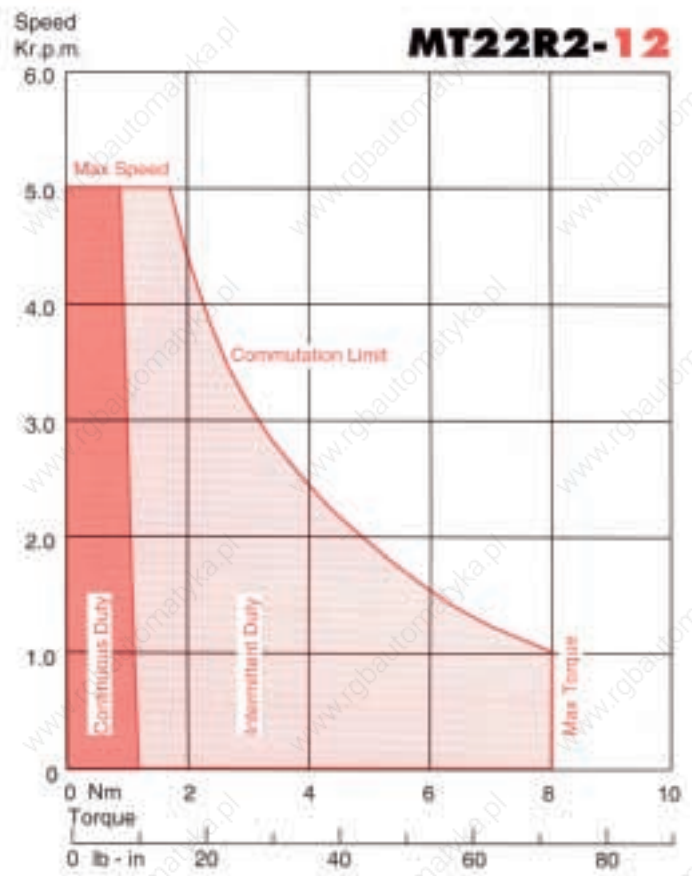
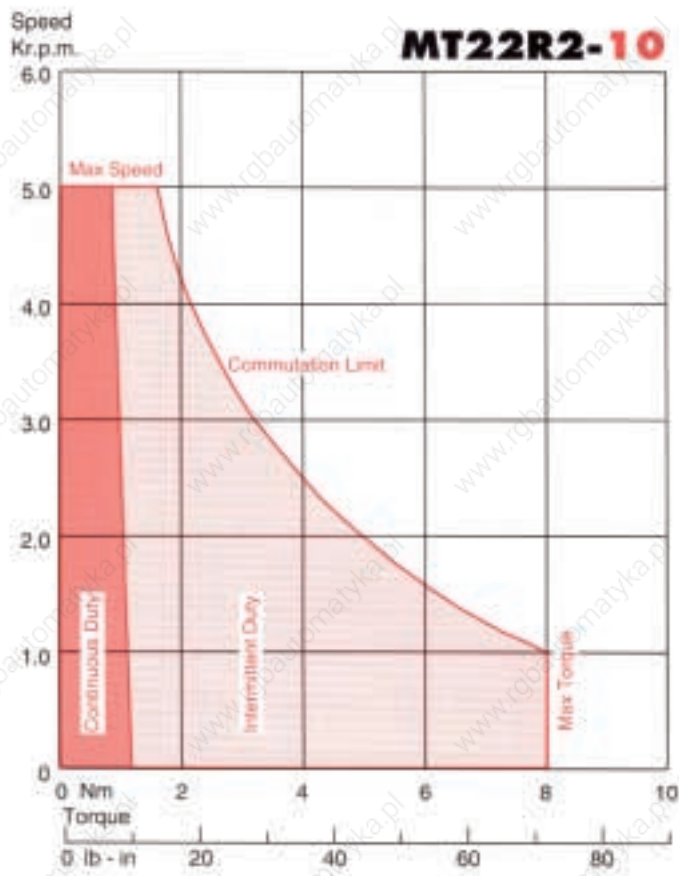

**STANDARD ARRANGEMENT**

TACHOGENERATOR

MOTOR WITH ENCODER ADAPTOR AND PIN TO SUIT BEC 755 ENCODER OR SUMTAK LHT ENCODER

∅ 5.992  
∅ 5.980

10

ENCODER ADAPTOR

FACE & SPIGOT ARE SQUARE & CONCENTRIC TO SHAFT WITHIN 0.08 TOTAL INDICATOR READING (0.04 FOR OPTION R01 ONLY)

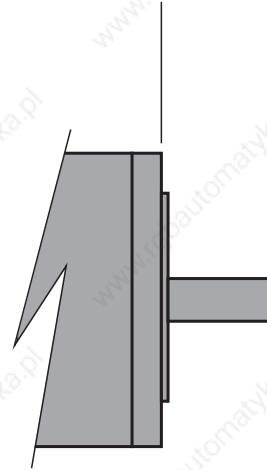

RUN OUT OF SHAFT WITHIN 0.05 TOTAL INDICATOR READING

STANDARD TOLERANCES CONFORM TO IEC72 (DIN 42955 TOLERANCE N)  
OPTION R01 CLOSE TOLERANCES CONFORM TO IEC72 PRECISION (DIN 42955 TOLERANCE R)

**NON DRIVE END SHAFT ARRANGEMENT**

**DRIVE END INTERFACE TOLERANCES**

DIMENSIONS IN MILLIMETRES

FOR INCH SERIES SEE DRAWING C-05623

**SHAFT LOADING LIMITS**

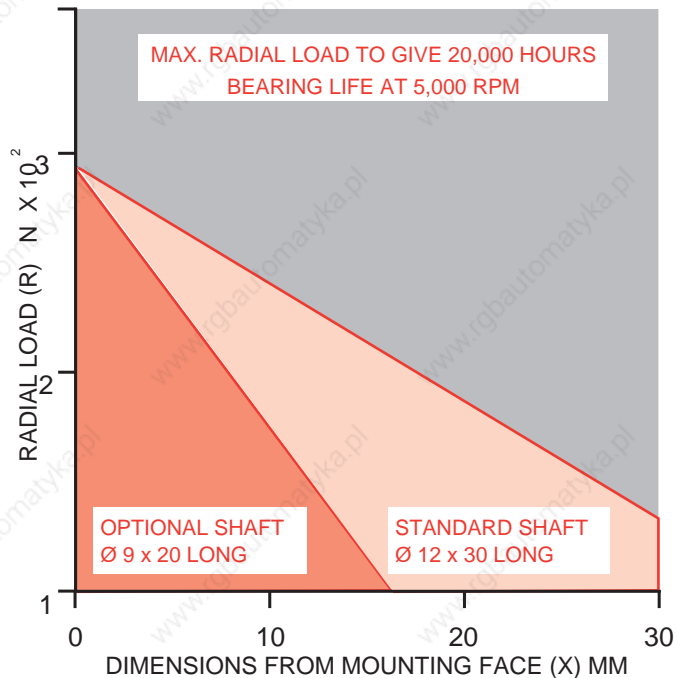
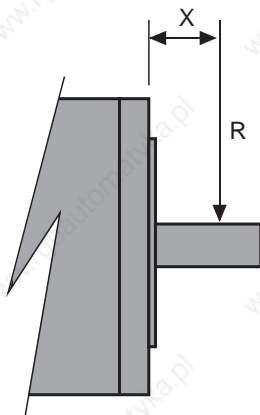

The above graph may be used as a guide for applications and includes an adequate safety factor for normal industrial use. If axial loads are to be applied, SEM should be consulted. Where radial loading in excess of the above maximum is deemed essential, the specific case should be referred to SEM.

METRIC D.C. SERVOMOTORS  
**MT22 SERIES**

**MECHANICAL DETAIL**

C - 05622  
SHEET 1 OF 2 SHEETS

DIMENSIONS IN MILLIMETRES FOR INCH SERIES SEE DRAWING C-05623

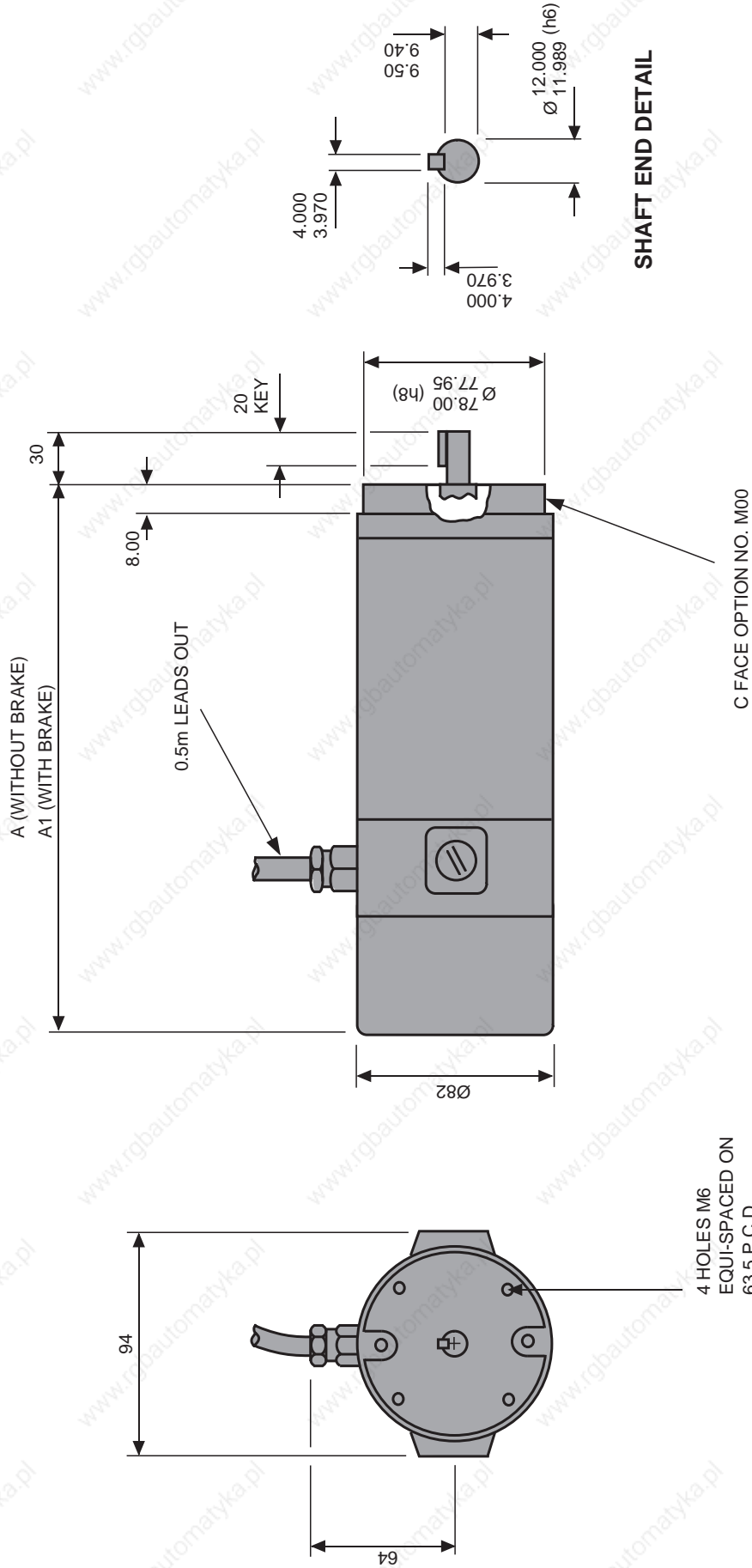

TYPE	A	A1
MT 22D2	173	203
MT 22G2	203	233
MT 22R2	263	293

METRIC D.C. SERVOMOTORS  
**MT22 SERIES**

# STANDARD MT22 SERVOMOTOR

**C - 05622**  
 SHEET 2 OF 2 SHEETS

DIMENSIONS IN MILLIMETRES FOR INCH SERIES SEE DRAWING C-05623

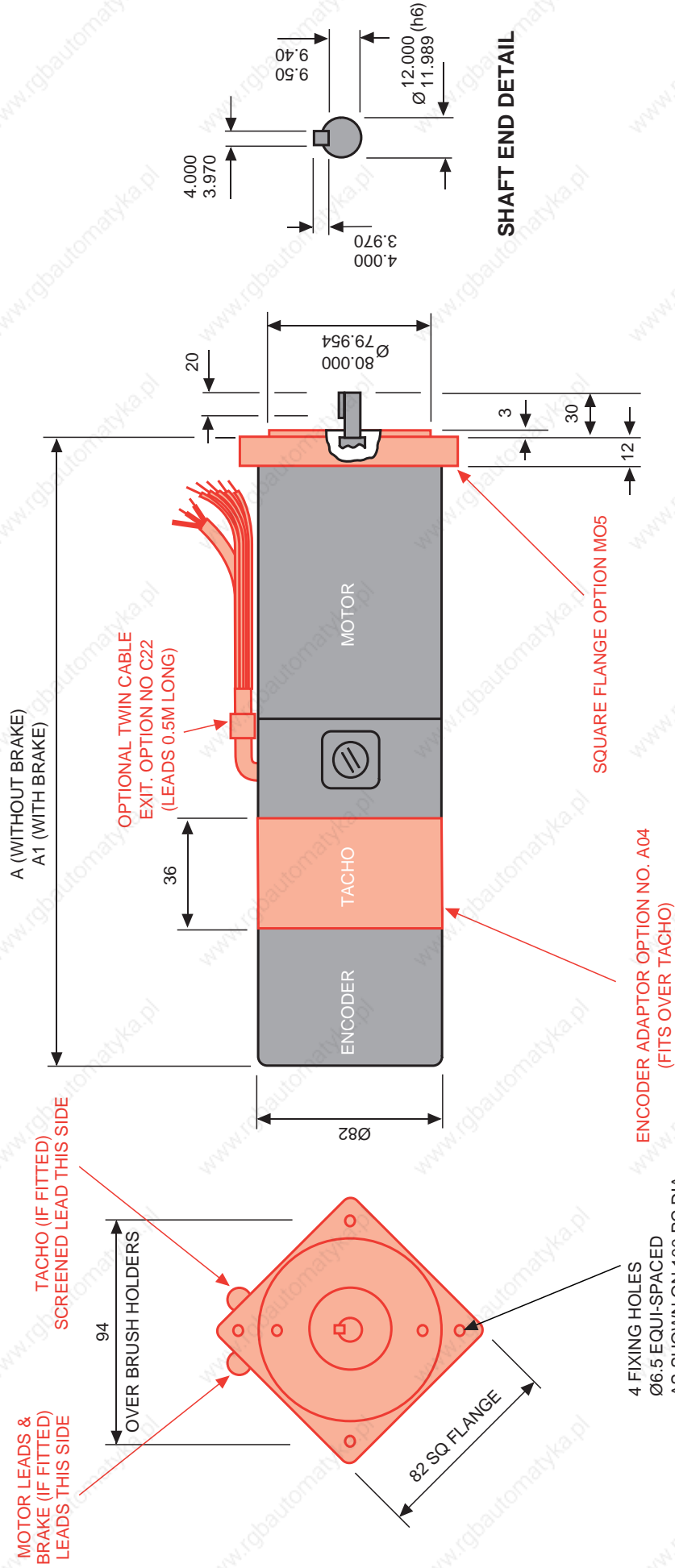

TYPE	A	A1
MT 22D2	209	239
MT 22G2	239	269
MT 22R2	299	329

METRIC D.C. SERVO MOTORS  
**MT22 SERIES**

**MT22 SERVO MOTOR**  
 WITH TWIN CABLE EXIT, SQUARE FLANGE AND ENCODER ADAPTOR  
 TO SUIT THE BEC755 & SUMTAK LHT ENCODERS SHOWN IN RED

**C - 05730**  
 SHEET 1 OF 1 SHEETS

Standard features are shown by ● in black.

Available fitted options are shown in red.

Please quote No. and reference of options along with motor type No. when placing an order.

If options or features are required which are not detailed below, they may be possible, so please ask SEM sales.

NO.	REFERENCE	DESCRIPTION
<b>MECHANICAL INTERFACE</b>		
● M00	FACE	See page 11
M05	SQUARE FLANGE	See page 12
R01	CLOSE TOLERANCE	Interface (face & shaft) to IEC72 PRECISION (DIN 42955 Tolerance R)
● S00	SHAFT	See page 11
S01	SHAFT	9mm Dia X 20mm Long (See page 12)
● K00	KEYWAY	See page 11
K01	KEYWAY	3mm x 3mm x 12mm long
K99	NO KEYWAY	Plain shaft
D02	SHAFT END TAPPED	M4 X 12mm Deep tapped in drive shaft
H01	HAND CRANK	Rear shaft to enable hand rotation of motor
<b>MOTOR PROTECTION</b>		
● P00	IP64 / IP65	Enclosure protection IP65. Shaft sealing IP64
P01	IP44	Enclosure protection IP44 when cable exit C22 is incorporated
● W01	SHAFT SEAL	Oil seal fitted at drive end/shaft interface
P99	TROPICALISED	Special treatment on internal parts
<b>BRAKES</b>		
B00	24V DC BRAKE	2 Nm torque, 24V DC supply
B01	90V DC BRAKE	2 Nm torque, 90V DC supply
L01	RECTIFIER	110V AC input, 90V DC output for B01 (supplied loose for external mounting)
<b>ELECTRICAL TERMINATIONS</b>		
● C00	LEADS OUT	0.5 metre long radial exit (No terminal box)
C01	MS CONNECTOR (IP44)	Receptacle MS3102A-24-7P (16 Pin) fitted to rear side cast cover G08 (IP44)
C04	MS PLUG & CABLE CLAMP FOR C01 (IP65)	Straight plug MS3106A-18-1S and cable clamp 97-3057-1010-1 (IP44)
C12	MS CONNECTOR (IP65)	Receptacle MS 3102E-24-7P (16 pin). As C01 but IP65
C13	MS PLUG & CABLE CLAMP FOR C12 (IP65)	Straight plug MS 3106E-18-1S (IP65)
C22	TWIN LEADS OUT (IP44 ONLY)	See page 12. Separate motor and tachometer leads out 0.5 m long secured to motor body
<b>TACHOGENERATORS</b>		
T07	TACHOGENERATOR	7V/1000 RPM
● T95	TACHOGENERATOR	9.5V/1000 RPM
T14	TACHOGENERATOR	14V/1000 RPM
N99	NO TACHOGENERATOR	No velocity feedback
<b>ENCODERS</b>		
E01	ENCODER	HEIDENHAIN ERN1120 Series - 250 PPR
E02	ENCODER	HEIDENHAIN ERN1120 Series - 500PPR
E03	ENCODER	HEIDENHAIN ERN1120 Series - 1000 PPR
<b>ENCODER FITTINGS</b>		
A04	ENCODER ADAPTOR	for BEC 755 encoder & SUMTAK model LHT encoder
A08	ENCODER ADAPTOR	for Heidenhain 1251/2 encoder
G01	ENCODER COVER (IP65)	Cast cover with 1 X M10 tapped hole and cable gland
G02	ENCODER COVER (IP65)	Cast cover with 1 X PG7 tapped hole and cable gland
C04	MS PLUG & CABLE CLAMP FOR G08 (IP44)	Straight plug MS3102A-24-7S & cable clamp 97-3057-1016-1
G08	ENCODER COVER (IP44)	Cast cover with receptacle MS3102A-24-7P (16 Pin) fitted
G14	ENCODER COVER (IP65)	Cast cover with receptacle MS 3102E-24-7P (16 Pin)
G26	MS PLUG & CABLE CLAMP FOR G14 (IP65)	Straight plug MS 3102E-24-7PS (IP75)

# MT30E4 D.C. Servomotors

## Technical Data

Parameter	Unit	MT30E4-52	MT30E4-32	MT30E4-25	MT30E4-20
<b>GENERAL</b>					
Voltage Gradient No Load	Volts/1000RPM*	52	32	25	20
Max. Terminal Voltage	Volts	140	130	100	80
Max. Speed	RPM	2700	4000	4000	4000
<b>Continuous Stall Torque TENV***</b>	<b>Nm</b>	<b>1.2</b>	<b>1.2</b>	<b>1.2</b>	<b>1.2</b>
	<b>lb - in</b>	<b>10.6</b>	<b>10.6</b>	<b>10.6</b>	<b>10.6</b>
Continuous Stall Torque Blower Cooled***	Nm	2.0	2.0	2.0	2.0
	lb - in	18	18	18	18
<b>Continuous Stall Current TENV***</b>	<b>Amps</b>	<b>2.5</b>	<b>4.1</b>	<b>5.4</b>	<b>7.0</b>
Armature Polar Moment of Inertia	Kgm <sup>2</sup>	0.0011	0.0011	0.0011	0.0011
	lb - in Sec <sup>2</sup>	0.01	0.01	0.01	0.01
<b>Torque Constant KT**</b>	<b>Nm/Amp*</b>	<b>0.48</b>	<b>0.29</b>	<b>0.22</b>	<b>0.17</b>
	<b>lb - in/Amp*</b>	<b>4.2</b>	<b>2.6</b>	<b>1.9</b>	<b>1.5</b>
Voltage Constant KV**	Volts Sec Rad <sup>-1*</sup>	0.48	0.29	0.22	0.17
Peak Stall Torque**	Nm	6.0	6.0	6.0	6.0
	lb - in	53	53	53	53
Current at Peak Torque**	Amps	13	22	29	37
Theoretical Acceleration at Peak Torque	Rad/Sec <sup>2</sup>	5500	5500	5500	5500
<b>Winding</b>					
Armature Resistance Less Brushes**	Ohms*	5.9	2.2	1.25	0.9
Armature Inductance	Millihenrys*	28	10	6	3.7
Mechanical Time Constant**	Milliseconds	30	30	30	30
<b>Thermal</b>					
Insulation Class		F	F	F	F
Max. Ambient Temperature	°C	40	40	40	40
Thermal Time Constant	Minutes*	40	40	40	40
<b>Mechanical</b>					
Static Friction Torque	Nm	0.15	0.15	0.15	0.15
	lb - in	1.3	1.3	1.3	1.3
Motor Weight	Kg	5.1	5.1	5.1	5.1
	lb	11	11	11	11
<b>TACHOMETER</b>					
Voltage Gradient	Volts/1000RPM*	9.5	STANDARD FOR USA ONLY		
	Volts Sec Rad <sup>-1*</sup>		7		
Ripple	Per Cent	1.0	1.0		
	Cycles/Rev	25	25		
Armature Resistance**	Ohms	36	24		
Armature Inductance	Millihenrys*	55	36		
Maximum Current	Amps	0.025	0.035		

\* Tolerance Plus or Minus 10%

\*\* At 25°C

\*\*\* At 40°C Ambient

■ **Motor Performance** data is on the basis of a pure D.C. i.e. unity system form factor supply. Appropriate performance derating is necessary when using a supply with a system form factor greater than unity.

■ **Commutation Curves** opposite and peak torque are based on the **peak value** of the current wave form. For a form factor greater than unity the maximum torque permitted will be lower than that detailed on the performance curves. **IMPORTANT** The commutation curves are based on a load inertia equal to the motor inertia. Advice should be taken in the event the load inertia is greater than the motor inertia.

● **Heatsink Ratings** Torque ratings shown in brackets (opposite top right) are correct for motors when fitted to a heatsink size (300mm x 300mm x 12mm)  
(12" x 12" x 0.5")

**STALL TORQUE 1.2Nm / 10.6lb-in**

**● (1.4Nm / 12.4lb-in)**

## Performance Curves

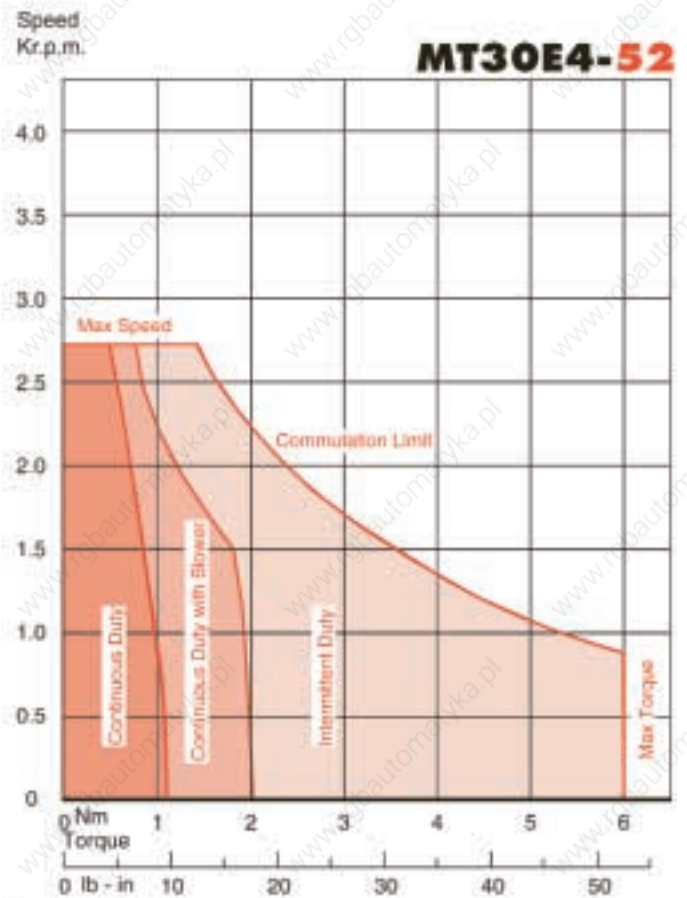
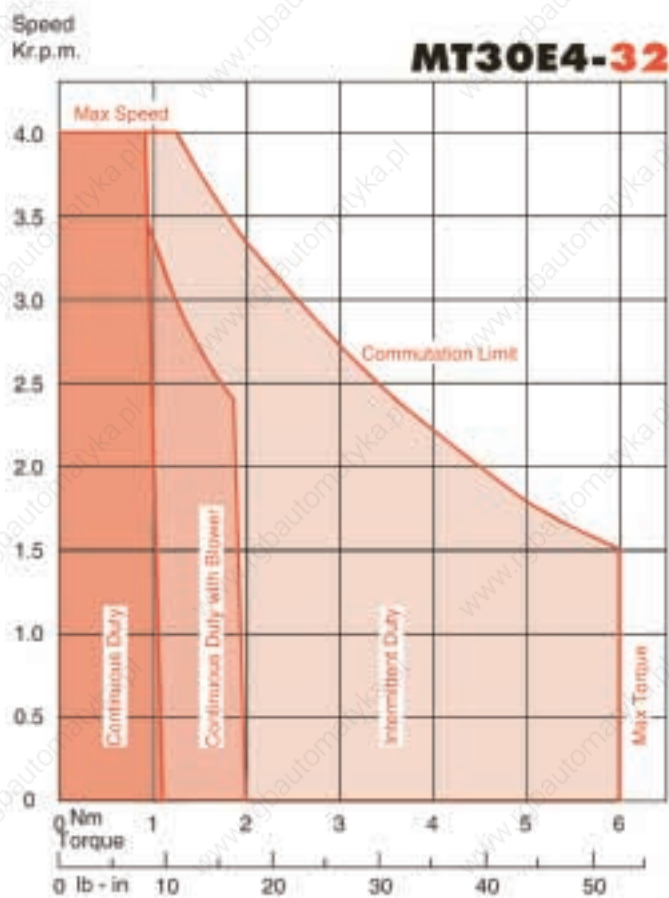
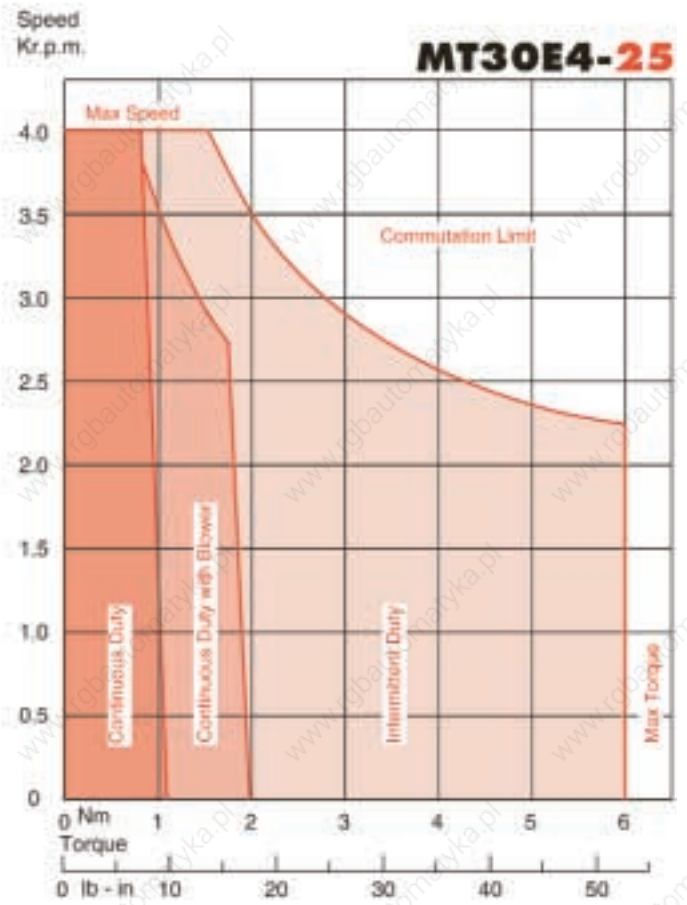
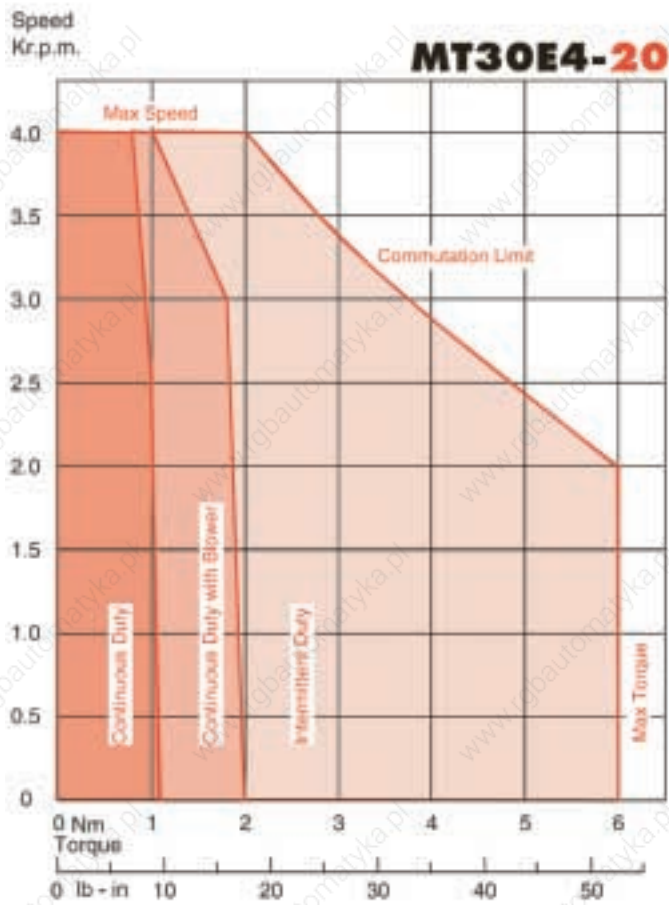

# MT30F4 D.C. Servomotors

## Technical Data

Parameter	Unit	MT30F4-52	MT30F4-45	MT30F4-39	MT30F4-25
<b>GENERAL</b>					
Voltage Gradient No Load	Volts/1000RPM*	52	45	39	25
Max. Terminal Voltage	Volts	140	140	140	100
Max. Speed	RPM	2700	3100	3600	4000
<b>Continuous Stall Torque TENV***</b>	<b>Nm</b>	<b>1.6</b>	<b>1.6</b>	<b>1.6</b>	<b>1.6</b>
	<b>lb - in</b>	<b>14</b>	<b>14</b>	<b>14</b>	<b>14</b>
Continuous Stall Torque Blower Cooled***	Nm	3.0	3.0	3.0	3.0
	lb - in	26	26	26	26
<b>Continuous Stall Current TENV***</b>	<b>Amps</b>	<b>3.4</b>	<b>3.9</b>	<b>4.4</b>	<b>7.0</b>
Armature Polar Moment of Inertia	Kgm <sup>2</sup>	0.0012	0.0012	0.0012	0.0012
	lb - in Sec <sup>2</sup>	0.011	0.011	0.011	0.011
<b>Torque Constant KT**</b>	<b>Nm/Amp*</b>	<b>0.47</b>	<b>0.41</b>	<b>0.36</b>	<b>0.23</b>
	<b>lb - in/Amp*</b>	<b>4.2</b>	<b>3.6</b>	<b>3.2</b>	<b>2.0</b>
Voltage Constant KV**	Volts Sec Rad <sup>-1*</sup>	0.47	0.41	0.36	0.23
Peak Stall Torque**	Nm	7.5	7.5	7.5	7.5
	lb - in	66	66	66	66
Current at Peak Torque**	Amps	18	21	24	34
Theoretical Acceleration at Peak Torque	Rad/Sec <sup>2</sup>	6200	6200	6200	6200
<b>Winding</b>					
Armature Resistance Less Brushes**	Ohms*	4.0	3.1	2.3	1.0
Armature Inductance	Millihenrys*	22.0	16.0	13.0	5.0
Mechanical Time Constant**	Milliseconds	23	23	23	25
<b>Thermal</b>					
Insulation Class		F	F	F	F
Max. Ambient Temperature	°C	40	40	40	40
Thermal Time Constant	Minutes*	40	40	40	40
<b>Mechanical</b>					
Static Friction Torque	Nm	0.15	0.15	0.15	0.15
	lb - in	1.3	1.3	1.3	1.3
Motor Weight	Kg	5.4	5.4	5.4	5.4
	lb	12	12	12	12
<b>TACHOMETER</b>					
Voltage Gradient	Volts/1000RPM*	9.5	STANDARD FOR USA ONLY		
	Volts Sec Rad <sup>-1*</sup>		7		
Ripple	Per Cent	1.0	1.0		
	Cycles/Rev	25	25		
Armature Resistance**	Ohms	36	24		
Armature Inductance	Millihenrys*	55	36		
Maximum Current	Amps	0.025	0.035		

\* Tolerance Plus or Minus 10%

\*\* At 25°C

\*\*\* At 40°C Ambient

■ **Motor Performance** data is on the basis of a pure D.C. i.e. unity system form factor supply. Appropriate performance derating is necessary when using a supply with a system form factor greater than unity.

■ **Commutation Curves** opposite and peak torque are based on the **peak value** of the current wave form. For a form factor greater than unity the maximum torque permitted will be lower than that detailed on the performance curves. **IMPORTANT** The commutation curves are based on a load inertia equal to the motor inertia. Advice should be taken in the event the load inertia is greater than the motor inertia.

● **Heatsink Ratings** Torque ratings shown in brackets (opposite top right) are correct for motors when fitted to a heatsink size (300mm x 300mm x 12mm)  
(12" x 12" x 0.5")

**STALL TORQUE 1.6Nm / 14lb-in**

**● (1.8Nm / 16.0lb-in)**

## Performance Curves

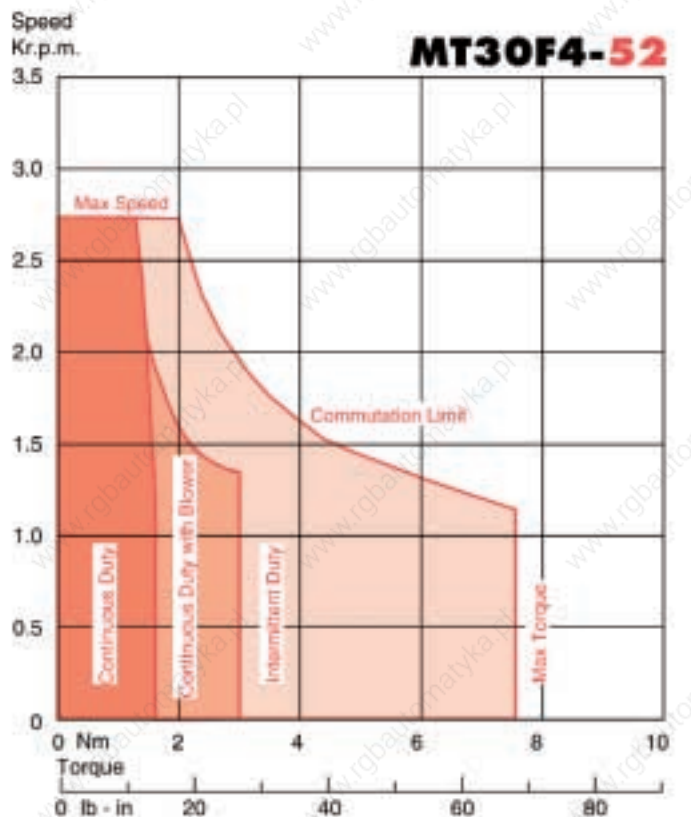
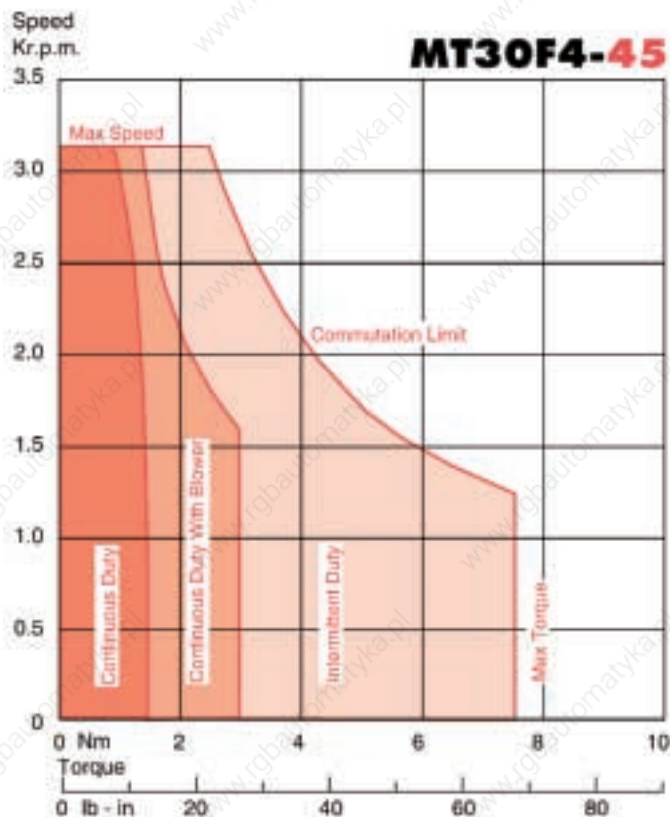
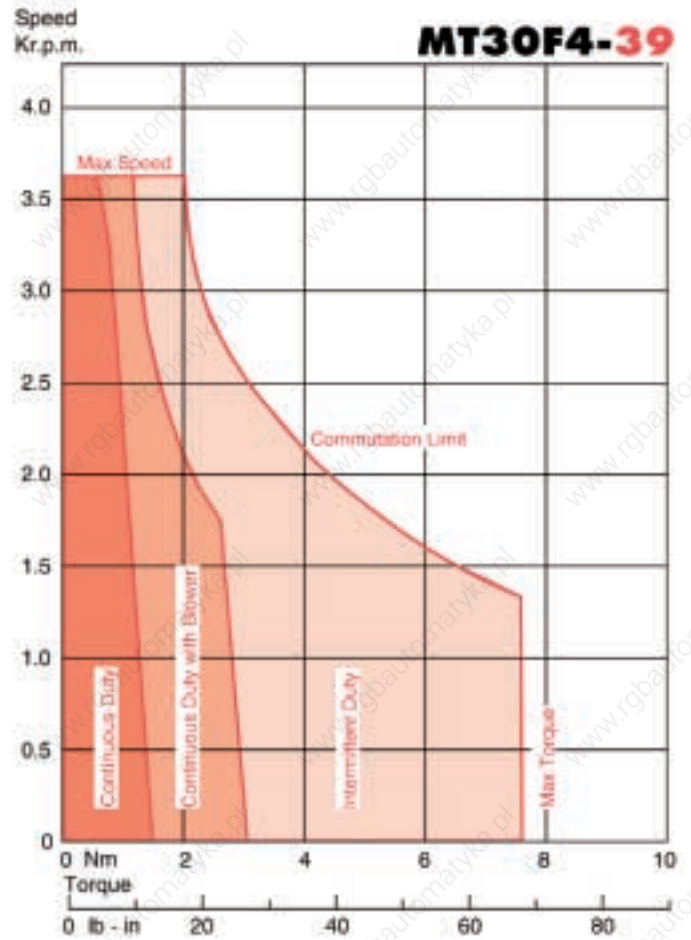
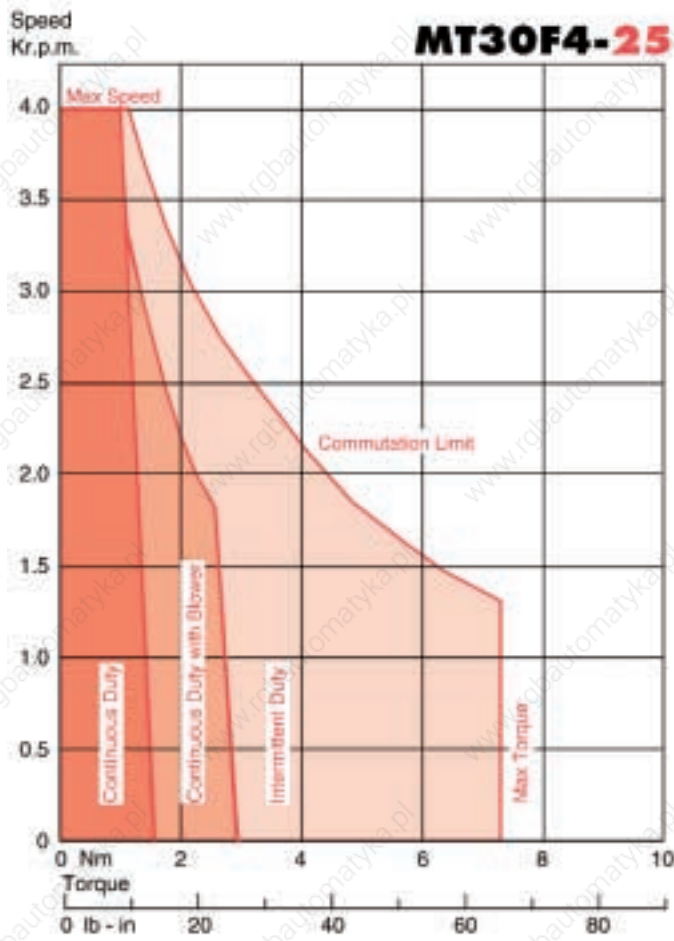

# MT30H4 D.C. Servomotors

## Technical Data

Parameter	Unit	MT30H4-65	MT30H4-44	MT30H4-33	MT30H4-22
<b>GENERAL</b>					
Voltage Gradient No Load	Volts/1000RPM*	65	44	33	22
Max. Terminal Voltage	Volts	140	140	130	90
Max. Speed	RPM	2100	3100	4000	4000
<b>Continuous Stall Torque TENV***</b>	<b>Nm</b>	<b>2.1</b>	<b>2.1</b>	<b>2.1</b>	<b>2.1</b>
	<b>lb - in</b>	<b>19</b>	<b>19</b>	<b>19</b>	<b>19</b>
Continuous Stall Torque Blower Cooled***	Nm	4.0	4.0	4.0	4.0
	lb - in	35	35	35	35
<b>Continuous Stall Current TENV***</b>	<b>Amps</b>	<b>3.5</b>	<b>4.4</b>	<b>6.8</b>	<b>10.5</b>
Armature Polar Moment of Inertia	Kgm <sup>2</sup>	0.0014	0.0014	0.0014	0.0014
	lb - in Sec <sup>2</sup>	0.012	0.012	0.012	0.012
<b>Torque Constant KT**</b>	<b>Nm/Amp*</b>	<b>0.61</b>	<b>0.43</b>	<b>0.31</b>	<b>0.20</b>
	<b>lb - in/Amp*</b>	<b>5.4</b>	<b>3.8</b>	<b>2.7</b>	<b>1.7</b>
Voltage Constant KV**	Volts Sec Rad <sup>-1*</sup>	0.61	0.43	0.31	0.20
Peak Stall Torque**	Nm	10.0	10.0	10.0	10.0
	lb - in	88	88	88	88
Current at Peak Torque**	Amps	18	26	37	57
Theoretical Acceleration at Peak Torque	Rad/Sec <sup>2</sup>	7100	7100	7100	7100
<b>Winding</b>					
Armature Resistance Less Brushes**	Ohms*	4.6	2.0	1.3	0.4
Armature Inductance	Millihenrys*	24.0	12.0	6.0	2.4
Mechanical Time Constant**	Milliseconds	18	18	18	18
<b>Thermal</b>					
Insulation Class		F	F	F	F
Max. Ambient Temperature	°C	40	40	40	40
Thermal Time Constant	Minutes*	50	50	50	50
<b>Mechanical</b>					
Static Friction Torque	Nm	0.15	0.15	0.15	0.15
	lb - in	1.3	1.3	1.3	1.3
Motor Weight	Kg	6.5	6.5	6.5	6.5
	lb	14	14	14	14
<b>TACHOMETER</b>					
Voltage Gradient	Volts/1000RPM*	9.5		7	
	Volts Sec Rad <sup>-1*</sup>	0.090		0.067	
Ripple	Per Cent	1.0		1.0	
	Cycles/Rev	25		25	
Armature Resistance**	Ohms	36		24	
Armature Inductance	Millihenrys*	55		36	
Maximum Current	Amps	0.025		0.035	

\* Tolerance Plus or Minus 10%

\*\* At 25°C

\*\*\* At 40°C Ambient

■ **Motor Performance** data is on the basis of a pure D.C. i.e. unity system form factor supply. Appropriate performance derating is necessary when using a supply with a system form factor greater than unity.

■ **Commutation Curves** opposite and peak torque are based on the **peak value** of the current wave form. For a form factor greater than unity the maximum torque permitted will be lower than that detailed on the performance curves. **IMPORTANT** The commutation curves are based on a load inertia equal to the motor inertia. Advice should be taken in the event the load inertia is greater than the motor inertia.

● **Heatsink Ratings** Torque ratings shown in brackets (opposite top right) are correct for motors when fitted to a heatsink size (300mm x 300mm x 12mm)  
(12" x 12" x 0.5")

**STALL TORQUE 2.1Nm / 19lb-in**

**● (2.3Nm / 20.4lb-in)**

## Performance Curves

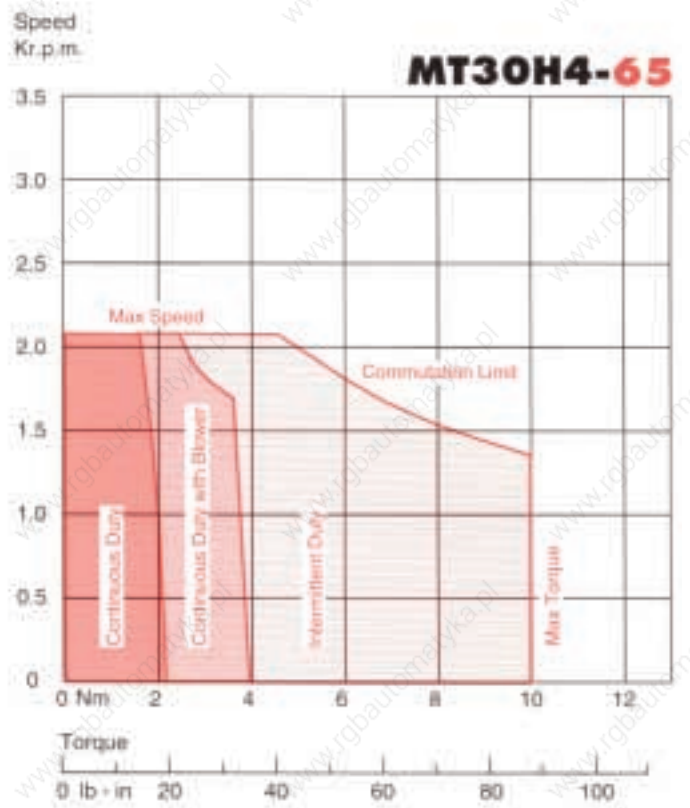
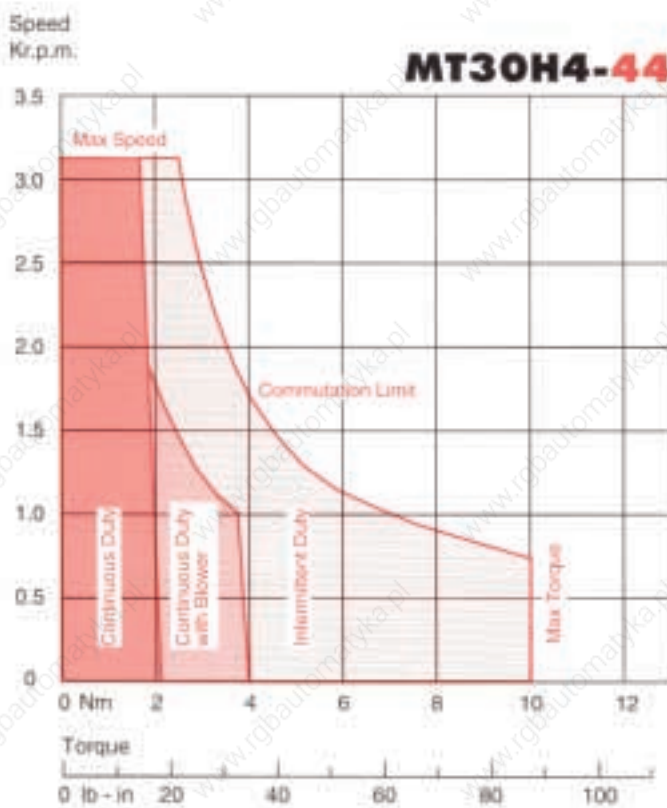
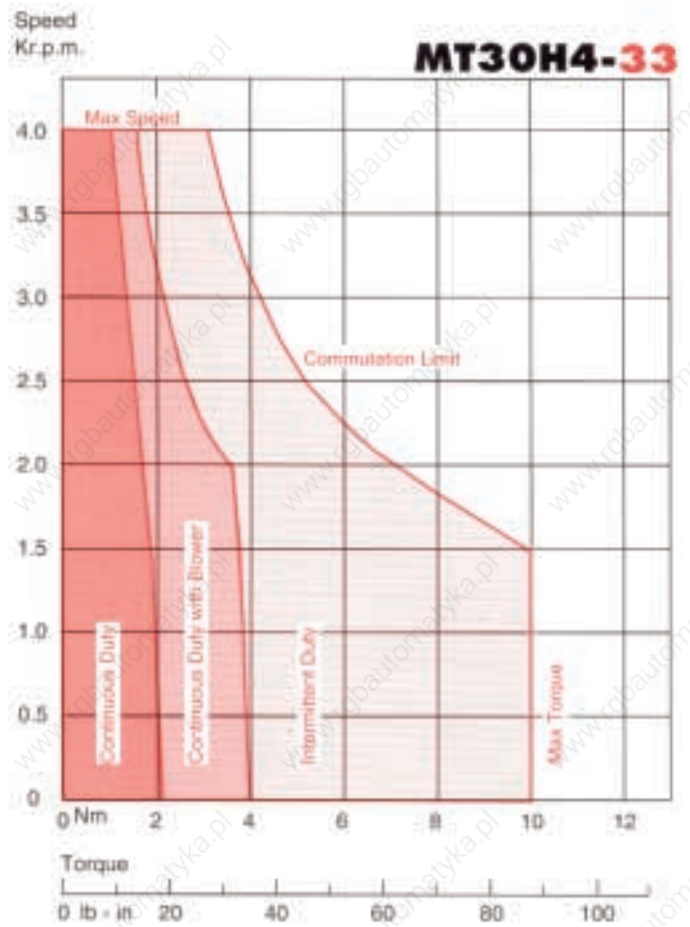
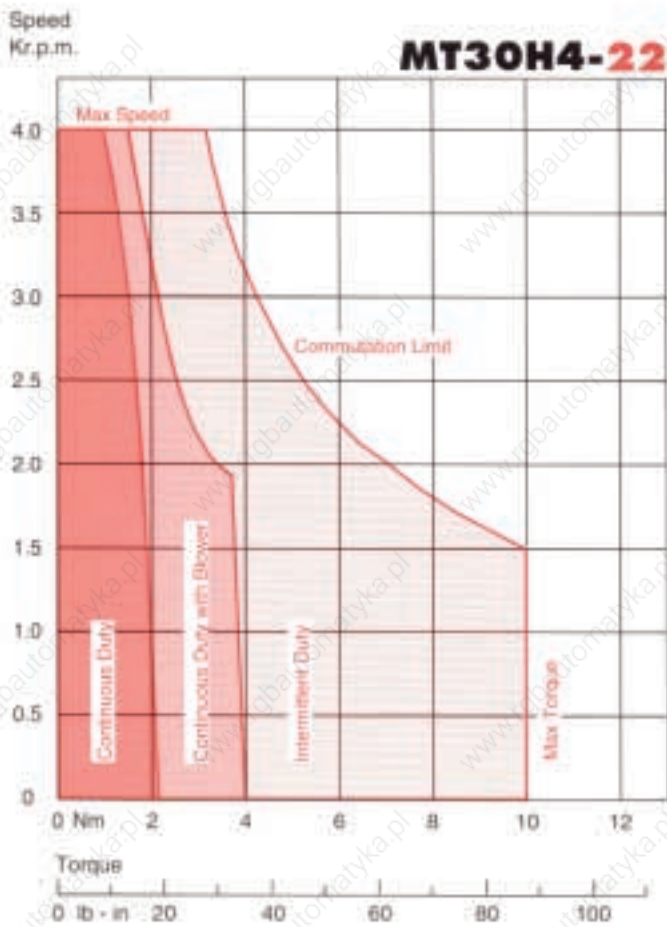

# MT30M4 D.C. Servomotors

## Technical Data

Parameter	Unit	MT30M4-59	MT30M4-48	MT30M4-38	MT30M4-24
<b>GENERAL</b>					
Voltage Gradient No Load	Volts/1000RPM*	59	48	38	24
Max. Terminal Voltage	Volts	140	140	140	100
Max. Speed	RPM	2400	3000	3700	4000
<b>Continuous Stall Torque TENV***</b>	<b>Nm</b>	<b>3.0</b>	<b>3.0</b>	<b>3.0</b>	<b>3.0</b>
	<b>lb - in</b>	<b>26</b>	<b>26</b>	<b>26</b>	<b>26</b>
Continuous Stall Torque Blower Cooled***	Nm	5.5	5.5	5.5	5.5
	lb - in	49	49	49	49
<b>Continuous Stall Current TENV***</b>	<b>Amps</b>	<b>5.5</b>	<b>6.8</b>	<b>8.6</b>	<b>13.6</b>
Armature Polar Moment of Inertia	Kgm <sup>2</sup>	0.0017	0.0017	0.0017	0.0017
	lb - in Sec <sup>2</sup>	0.015	0.015	0.015	0.015
<b>Torque Constant KT**</b>	<b>Nm/Amp*</b>	<b>0.54</b>	<b>0.44</b>	<b>0.35</b>	<b>0.22</b>
	<b>lb - in/Amp*</b>	<b>4.8</b>	<b>3.9</b>	<b>3.1</b>	<b>1.9</b>
Voltage Constant KV**	Volts Sec Rad <sup>-1*</sup>	0.54	0.44	0.35	0.22
Peak Stall Torque**	Nm	14	14	14	14
	lb - in	124	124	124	124
Current at Peak Torque**	Amps	30	37	47	75
Theoretical Acceleration at Peak Torque	Rad/Sec <sup>2</sup>	8200	8200	8200	8200
<b>Winding</b>					
Armature Resistance Less Brushes**	Ohms*	2.0	1.3	0.82	0.33
Armature Inductance	Millihenrys*	15.5	10.5	6.5	2.6
Mechanical Time Constant**	Milliseconds	13	13	15	18
<b>Thermal</b>					
Insulation Class		F	F	F	F
Max. Ambient Temperature	°C	40	40	40	40
Thermal Time Constant	Minutes*	50	50	50	50
<b>Mechanical</b>					
Static Friction Torque	Nm	0.15	0.15	0.15	0.15
	lb - in	1.3	1.3	1.3	1.3
Motor Weight	Kg	7.3	7.3	7.3	7.3
	lb	16	16	16	16
<b>TACHOMETER</b>					
Voltage Gradient	Volts/1000RPM*	9.5	STANDARD FOR USA ONLY		
	Volts Sec Rad <sup>-1*</sup>		7		
Ripple	Per Cent	1.0	0.067		
	Cycles/Rev		1.0		
Armature Resistance**	Ohms	36	24		
Armature Inductance	Millihenrys*	55	36		
Maximum Current	Amps	0.025	0.035		

\* Tolerance Plus or Minus 10%

\*\* At 25°C

\*\*\* At 40°C Ambient

■ **Motor Performance** data is on the basis of a pure D.C. i.e. unity system form factor supply. Appropriate performance derating is necessary when using a supply with a system form factor greater than unity.

■ **Commutation Curves** opposite and peak torque are based on the **peak value** of the current wave form. For a form factor greater than unity the maximum torque permitted will be lower than that detailed on the performance curves. **IMPORTANT** The commutation curves are based on a load inertia equal to the motor inertia. Advice should be taken in the event the load inertia is greater than the motor inertia.

● **Heatsink Ratings** Torque ratings shown in brackets (opposite top right) are correct for motors when fitted to a heatsink size (300mm x 300mm x 12mm)  
(12" x 12" x 0.5")

**STALL TORQUE 3.0Nm / 26lb-in**

**● (3.3Nm / 29lb-in)**

## Performance Curves

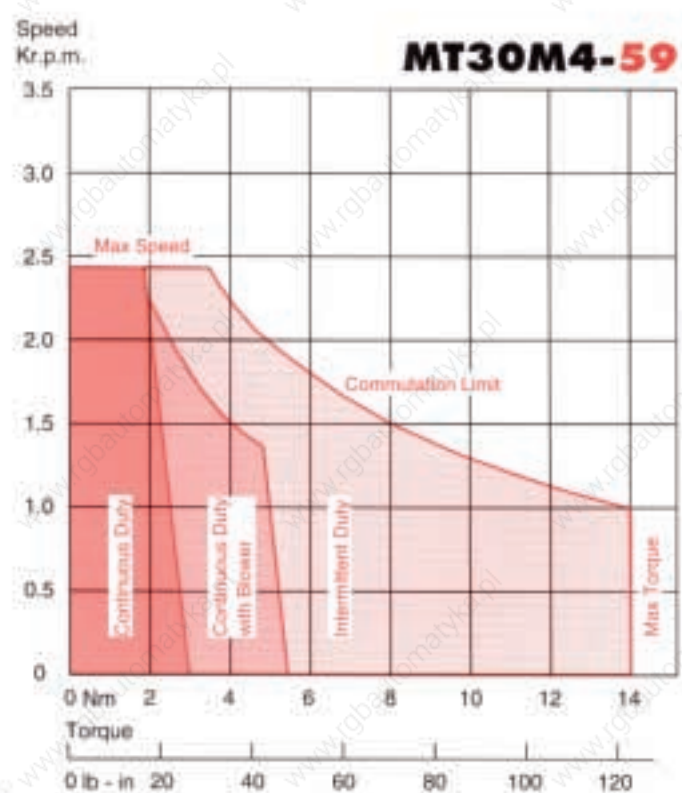
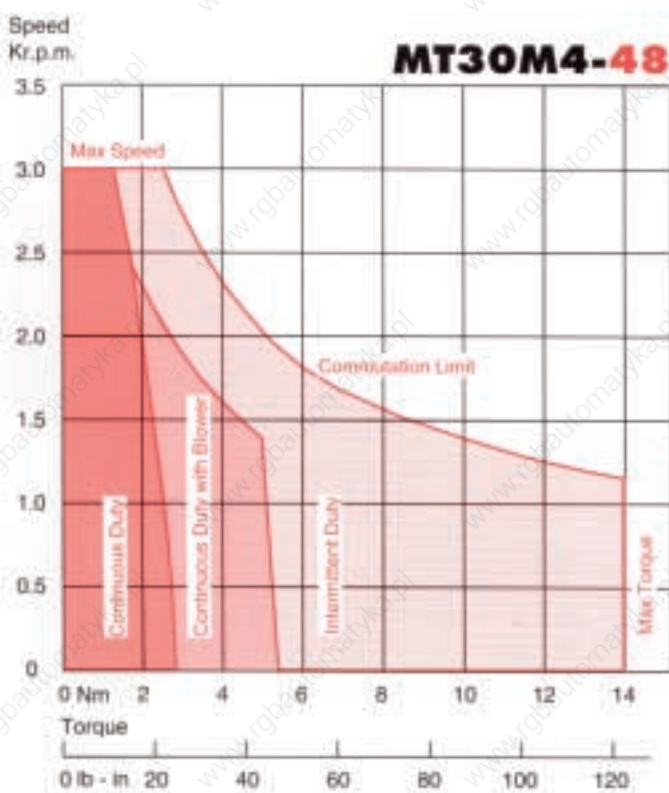
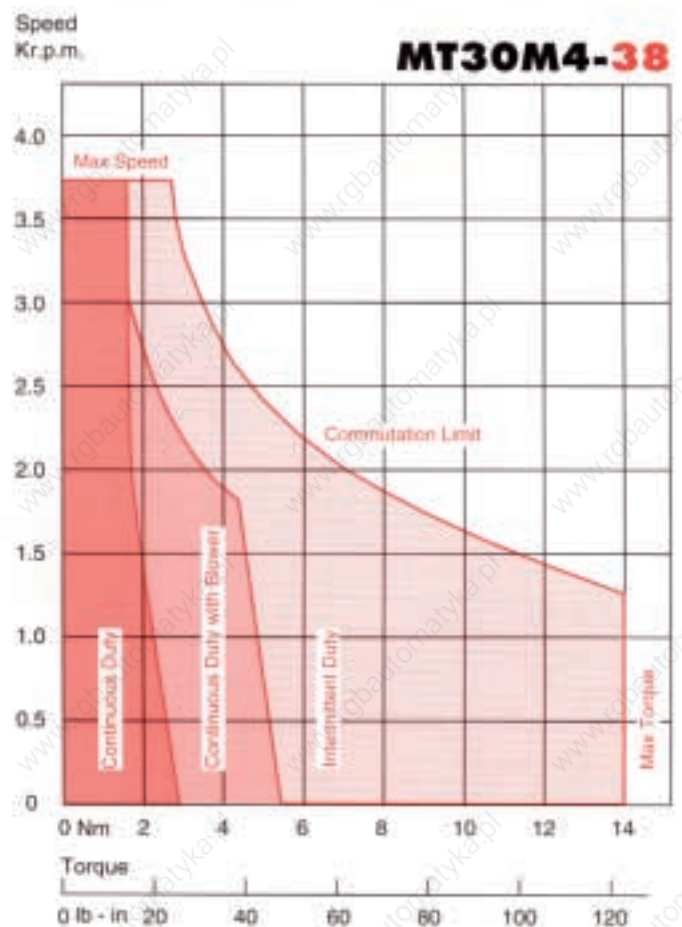
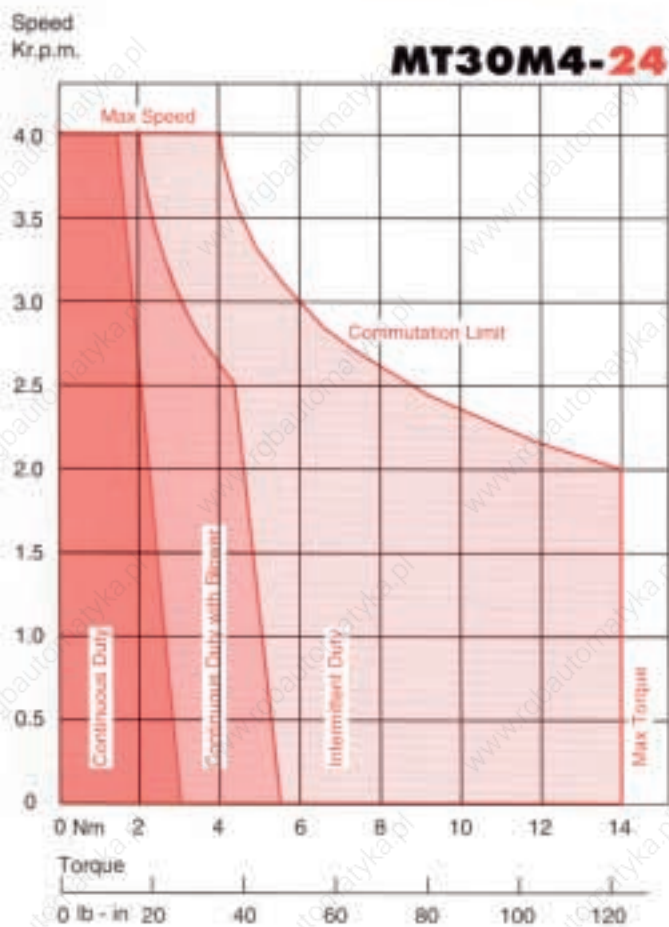

# MT3OR4 D.C. Servomotors

## Technical Data

Parameter	Unit	MT3OR4-58	MT3OR4-46	MT3OR4-37	MT3OR4-25
<b>GENERAL</b>					
Voltage Gradient No Load	Volts/1000RPM*	58	46	37	25
Max. Terminal Voltage	Volts	140	140	140	100
Max. Speed	RPM	2500	3000	3800	4000
<b>Continuous Stall Torque TENV***</b>	<b>Nm</b>	<b>3.5</b>	<b>3.5</b>	<b>3.5</b>	<b>3.2</b>
	<b>lb - in</b>	<b>30.0</b>	<b>30.0</b>	<b>30.0</b>	<b>28.0</b>
Continuous Stall Torque Blower Cooled***	Nm	6.0	6.0	6.0	6.0
	lb - in	53	53	53	53
<b>Continuous Stall Current TENV***</b>	<b>Amps</b>	<b>6.1</b>	<b>7.6</b>	<b>9.5</b>	<b>13.3</b>
Armature Polar Moment of Inertia	Kgm <sup>2</sup>	0.0020	0.0020	0.0020	0.0020
	lb - in Sec <sup>2</sup>	0.018	0.018	0.018	0.018
<b>Torque Constant KT**</b>	<b>Nm/Amp*</b>	<b>0.57</b>	<b>0.46</b>	<b>0.37</b>	<b>0.24</b>
	<b>lb - in/Amp*</b>	<b>5.0</b>	<b>4.0</b>	<b>3.3</b>	<b>2.1</b>
Voltage Constant KV**	Volts Sec Rad <sup>-1*</sup>	0.57	0.46	0.37	0.24
Peak Stall Torque**	Nm	18.0	18.0	18.0	18.0
	lb - in	160	160	160	160
Current at Peak Torque**	Amps	37	47	57	86
Theoretical Acceleration at Peak Torque	Rad/Sec <sup>2</sup>	9000	9000	9000	9000
<b>Winding</b>					
Armature Resistance Less Brushes**	Ohms*	1.7	0.90	0.72	0.40
Armature Inductance	Millihenrys*	11.5	7.0	5.0	2.2
Mechanical Time Constant**	Milliseconds	11.0	11.0	12.0	14.0
<b>Thermal</b>					
Insulation Class		F	F	F	F
Max. Ambient Temperature	°C	40	40	40	40
Thermal Time Constant	Minutes*	60	60	60	60
<b>Mechanical</b>					
Static Friction Torque	Nm	0.20	0.20	0.20	0.20
	lb - in	1.8	1.8	1.8	1.8
Motor Weight	Kg	8.3	8.3	8.3	8.3
	lb	18	18	18	18
<b>TACHOMETER</b>					
Voltage Gradient	Volts/1000RPM*				STANDARD FOR USA ONLY
	Volts Sec Rad <sup>-1*</sup>	9.5		7	
Ripple	Per Cent	1.0		1.0	
	Cycles/Rev	25		25	
Armature Resistance**	Ohms	36		24	
Armature Inductance	Millihenrys*	55		36	
Maximum Current	Amps	0.025		0.035	

- \* Tolerance Plus or Minus 10%
- \*\* At 25°C
- \*\*\* At 40°C Ambient

■ **Motor Performance** data is on the basis of a pure D.C. i.e. unity system form factor supply. Appropriate performance derating is necessary when using a supply with a system form factor greater than unity.

■ **Commutation Curves** opposite and peak torque are based on the **peak value** of the current wave form. For a form factor greater than unity the maximum torque permitted will be lower than that detailed on the performance curves. **IMPORTANT** The commutation curves are based on a load inertia equal to the motor inertia. Advice should be taken in the event the load inertia is greater than the motor inertia.

● **Heatsink Ratings** Torque ratings shown in brackets (opposite top right) are correct for motors when fitted to a heatsink size (300mm x 300mm x 12mm)  
(12" x 12" x 0.5")

# STALL TORQUE 3.2 - 3.5Nm / 28 - 30lb-in

- (R4-25) 3.3Nm / 29lb-in
- (R4-37) 3.6Nm / 31lb-in
- (R4-46 & 58) 4.0Nm / 35lb-in

## Performance Curves

Speed  
Kr.p.m.

### MT30R4-25

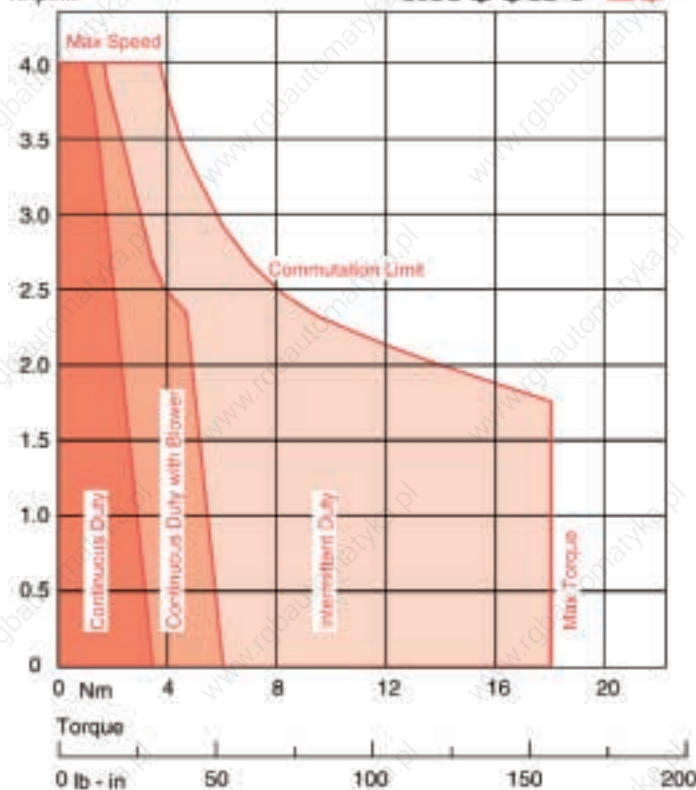

Speed  
Kr.p.m.

### MT30R4-37

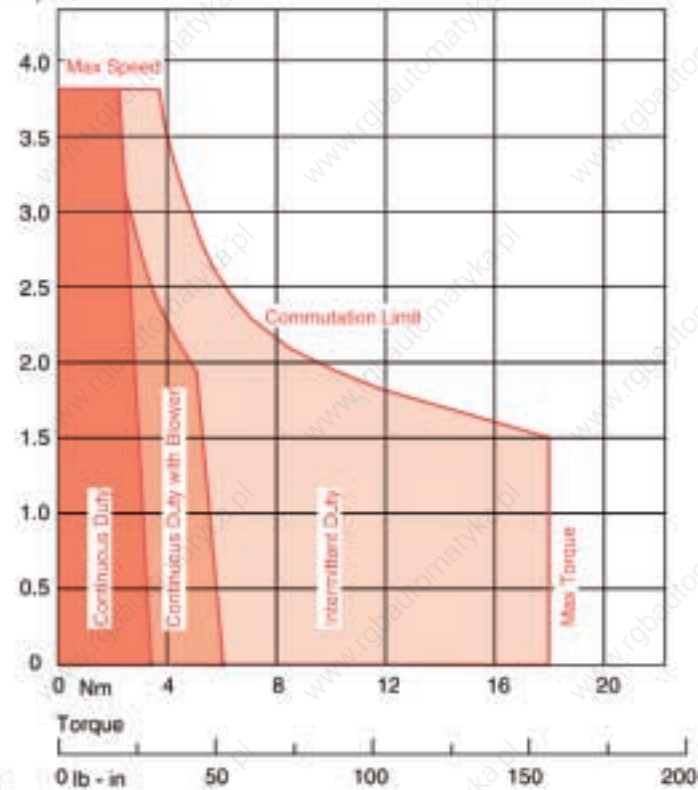

Speed  
Kr.p.m.

### MT30R4-46

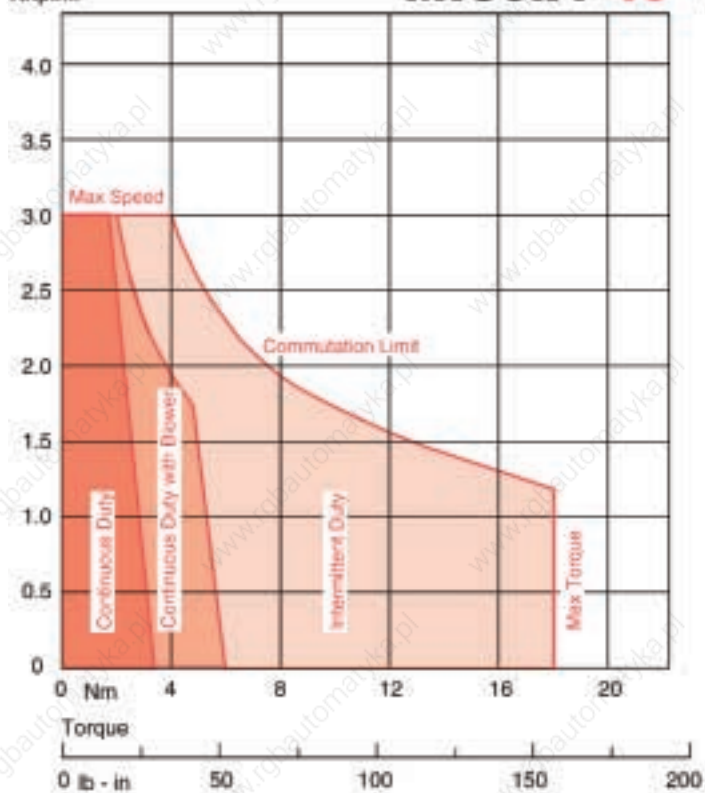

Speed  
Kr.p.m.

### MT30R4-58

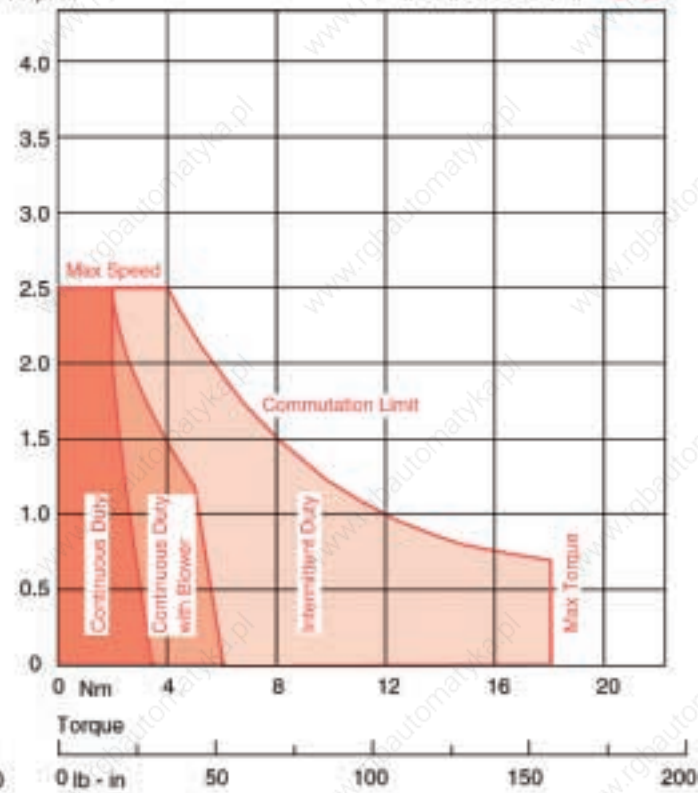

# MT30U4 D.C. Servomotors

## Technical Data

Parameter	Unit	MT30U4-57	MT30U4-48	MT30U4-36	MT30U4-26
<b>GENERAL</b>					
Voltage Gradient No Load	Volts/1000RPM*	57	48	36	26
Max. Terminal Voltage	Volts	140	140	140	100
Max. Speed	RPM	2500	3000	4000	4000
<b>Continuous Stall Torque TENV***</b>	<b>Nm</b>	<b>4.5</b>	<b>4.5</b>	<b>4.5</b>	<b>4.0</b>
	<b>lb - in</b>	<b>40</b>	<b>40</b>	<b>40</b>	<b>35</b>
Continuous Stall Torque Blower Cooled***	Nm	8.0	8.0	8.0	7.0
	lb - in	71	71	71	62
<b>Continuous Stall Current TENV***</b>	<b>Amps</b>	<b>8.3</b>	<b>10.2</b>	<b>13.2</b>	<b>16.6</b>
Armature Polar Moment of Inertia	Kgm <sup>2</sup>	0.0023	0.0023	0.0023	0.0023
	lb - in Sec <sup>2</sup>	0.020	0.020	0.020	0.020
<b>Torque Constant KT**</b>	<b>Nm/Amp*</b>	<b>0.54</b>	<b>0.44</b>	<b>0.34</b>	<b>0.24</b>
	<b>lb - in/Amp*</b>	<b>4.8</b>	<b>3.9</b>	<b>3.0</b>	<b>2.1</b>
Voltage Constant KV**	Volts Sec Rad <sup>-1*</sup>	0.54	0.44	0.34	0.24
Peak Stall Torque**	Nm	22	22	22	22
	lb - in	195	195	195	195
Current at Peak Torque**	Amps	47	57	75	100
Theoretical Acceleration at Peak Torque	Rad/Sec <sup>2</sup>	9600	9600	9600	9600
<b>Winding</b>					
Armature Resistance Less Brushes**	Ohms*	1.1	0.72	0.45	0.22
Armature Inductance	Millihenrys*	8.1	5.5	3.3	1.7
Mechanical Time Constant**	Milliseconds	10	11	13	16
<b>Thermal</b>					
Insulation Class		F	F	F	F
Max. Ambient Temperature	°C	40	40	40	40
Thermal Time Constant	Minutes*	60	60	60	60
<b>Mechanical</b>					
Static Friction Torque	Nm	0.20	0.20	0.20	0.20
	lb - in	1.8	1.8	1.8	1.8
Motor Weight	Kg	9.3	9.3	9.3	9.3
	lb	20	20	20	20
<b>TACHOMETER</b>					
Voltage Gradient	Volts/1000RPM*	9.5	STANDARD FOR USA ONLY		
	Volts Sec Rad <sup>-1*</sup>		7		
Ripple	Per Cent	1.0	1.0		
	Cycles/Rev	25	25		
Armature Resistance**	Ohms	36	24		
Armature Inductance	Millihenrys*	55	36		
Maximum Current	Amps	0.025	0.035		

\* Tolerance Plus or Minus 10%

\*\* At 25°C

\*\*\* At 40°C Ambient

■ **Motor Performance** data is on the basis of a pure D.C. i.e. unity system form factor supply. Appropriate performance derating is necessary when using a supply with a system form factor greater than unity.

■ **Commutation Curves** opposite and peak torque are based on the **peak value** of the current wave form. For a form factor greater than unity the maximum torque permitted will be lower than that detailed on the performance curves. **IMPORTANT** The commutation curves are based on a load inertia equal to the motor inertia. Advice should be taken in the event the load inertia is greater than the motor inertia.

● **Heatsink Ratings** Torque ratings shown in brackets (opposite top right) are correct for motors when fitted to a heatsink size (300mm x 300mm x 12mm)  
(12" x 12" x 0.5")

# STALL TORQUE 4.0 - 4.5Nm / 35 - 40lb-in

- (U4-26 4.3Nm / 38lb-in)
- (U4-36 4.6Nm / 41lb-in)
- (U4-48 & 57 4.9Nm / 43lb-in)

## Performance Curves

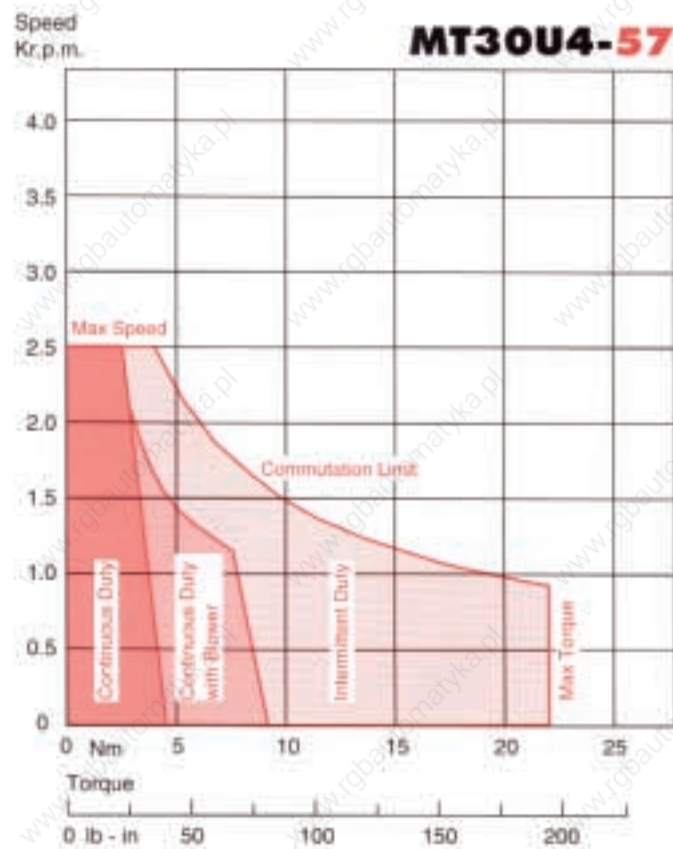
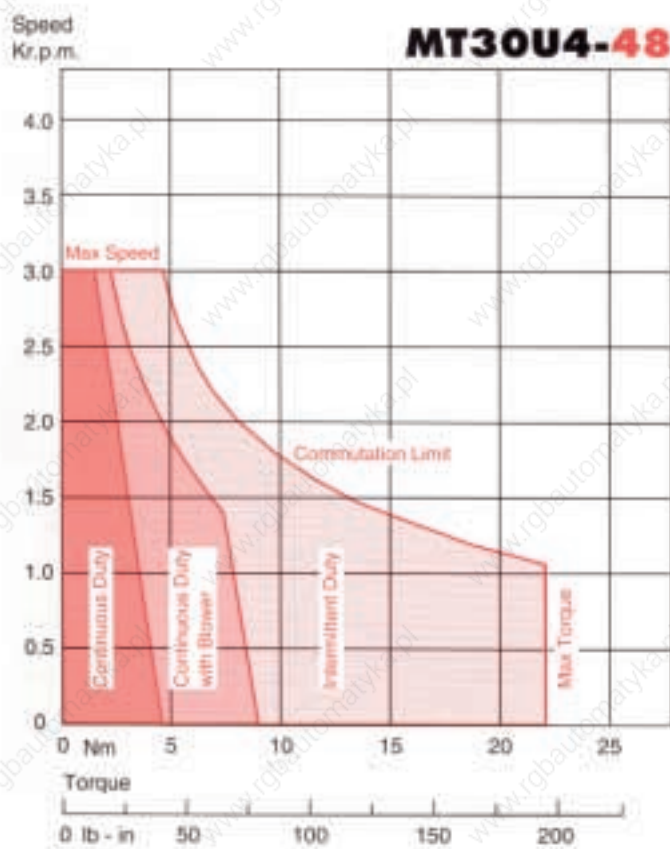
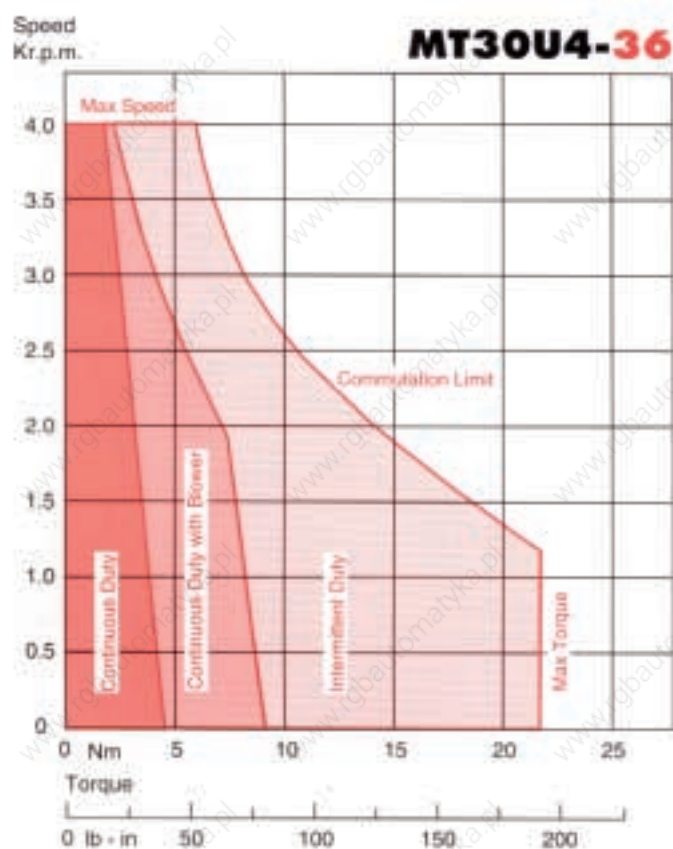
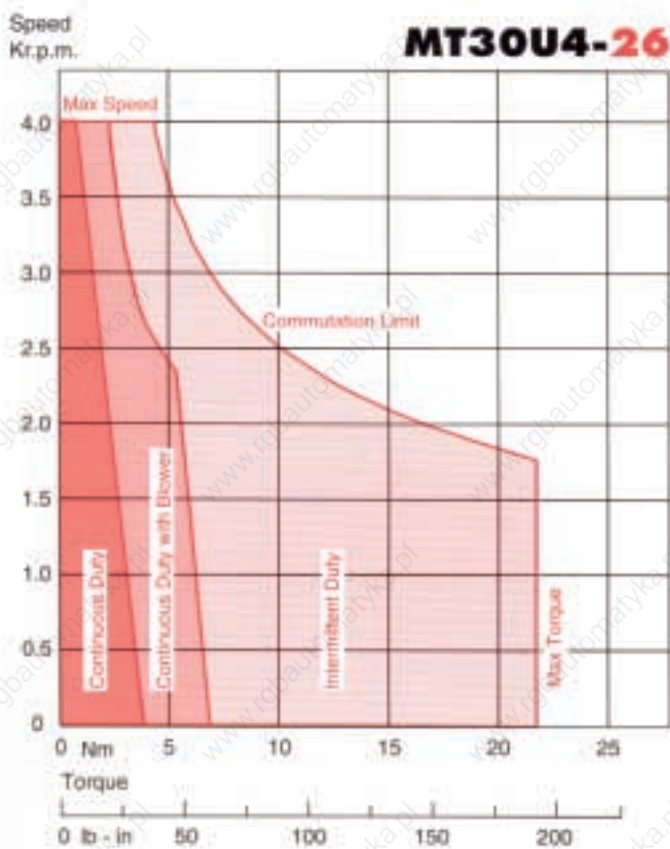

# MT30Z4 D.C. Servomotors

## Technical Data

Parameter	Unit	MT30Z4-85	MT30Z4-61	MT30Z4-37
<b>GENERAL</b>				
Voltage Gradient No Load	Volts/1000RPM*	85	61	37
Max. Terminal Voltage	Volts	140	140	140
Max. Speed	RPM	1600	2300	3750
<b>Continuous Stall Torque TENV***</b>	<b>Nm</b>	<b>5.5</b>	<b>5.0</b>	<b>4.4</b>
	<b>lb - in</b>	<b>48</b>	<b>44</b>	<b>39</b>
Continuous Stall Torque Blower Cooled***	Nm	10.0	9.0	8.0
	lb - in	88	80	70
<b>Continuous Stall Current TENV***</b>	<b>Amps</b>	<b>6.8</b>	<b>8.6</b>	<b>12.6</b>
Armature Polar Moment of Inertia	Kgm <sup>2</sup>	0.0030	0.0030	0.0030
	lb - in Sec <sup>2</sup>	0.027	0.027	0.027
<b>Torque Constant KT**</b>	<b>Nm/Amp*</b>	<b>0.81</b>	<b>0.58</b>	<b>0.35</b>
	<b>lb - in/Amp*</b>	<b>7.2</b>	<b>5.1</b>	<b>3.1</b>
Voltage Constant KV**	Volts Sec Rad <sup>-1*</sup>	0.81	0.58	0.35
Peak Stall Torque**	Nm	26.0	26.0	26.0
	lb - in	230	230	230
Current at Peak Torque**	Amps	32.0	50.0	86.0
Theoretical Acceleration at Peak Torque	Rad/Sec <sup>2</sup>	8700	8700	8700
<b>Winding</b>				
Armature Resistance Less Brushes**	Ohms*	2.2	1.2	0.35
Armature Inductance	Millihenrys*	17.0	8.0	3.0
Mechanical Time Constant**	Milliseconds	12.0	12.0	10.0
<b>Thermal</b>				
Insulation Class		F	F	F
Max. Ambient Temperature	°C	40	40	40
Thermal Time Constant	Minutes*	60	60	60
<b>Mechanical</b>				
Static Friction Torque	Nm	0.20	0.20	0.20
	lb - in	1.8	1.8	1.8
Motor Weight	Kg	11.3	11.3	11.3
	lb	25	25	25
<b>TACHOMETER</b>				
Voltage Gradient	Volts/1000RPM*	9.5	7	
	Volts Sec Rad <sup>-1*</sup>	0.090	0.067	
Ripple	Per Cent	1.0	1.0	
	Cycles/Rev	25	25	
Armature Resistance**	Ohms	36	24	
Armature Inductance	Millihenrys*	55	36	
Maximum Current	Amps	0.025	0.035	

\* Tolerance Plus or Minus 10%

\*\* At 25°C

\*\*\* At 40°C Ambient

■ **Motor Performance** data is on the basis of a pure D.C. i.e. unity system form factor supply. Appropriate performance derating is necessary when using a supply with a system form factor greater than unity.

■ **Commutation Curves** opposite and peak torque are based on the **peak value** of the current wave form. For a form factor greater than unity the maximum torque permitted will be lower than that detailed on the performance curves. **IMPORTANT** The commutation curves are based on a load inertia equal to the motor inertia. Advice should be taken in the event the load inertia is greater than the motor inertia.

● **Heatsink Ratings** Torque ratings shown in brackets (opposite top right) are correct for motors when fitted to a heatsink size (300mm x 300mm x 12mm)  
(12" x 12" x 0.5")

# STALL TORQUE 4.4 - 5.5Nm / 39 - 48lb-in

- (Z4-37 4.6Nm / 41lb-in)
- (Z4-61 5.2Nm / 46lb-in)
- (Z4-85 6.0Nm / 53lb-in)

## Performance Curves

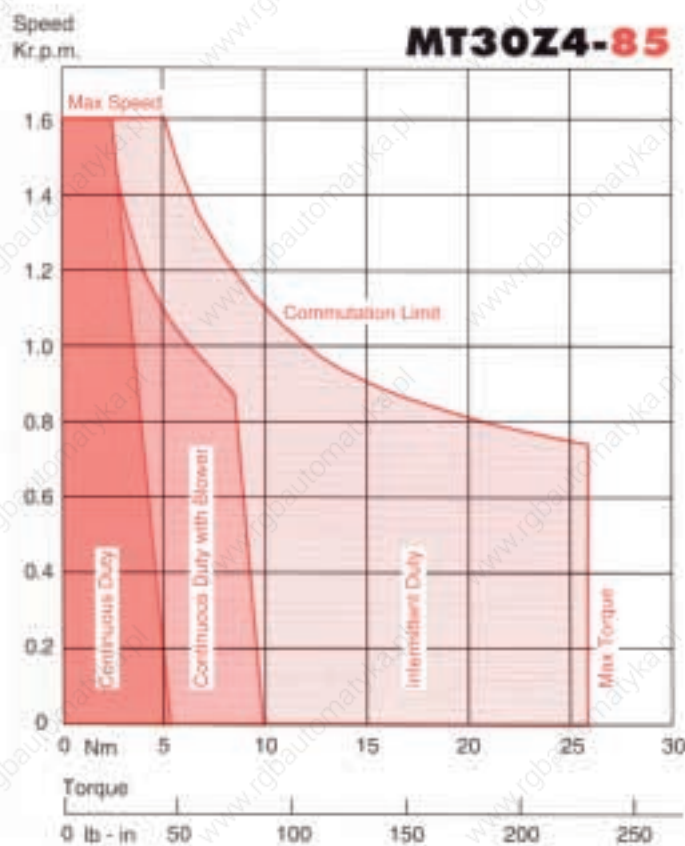
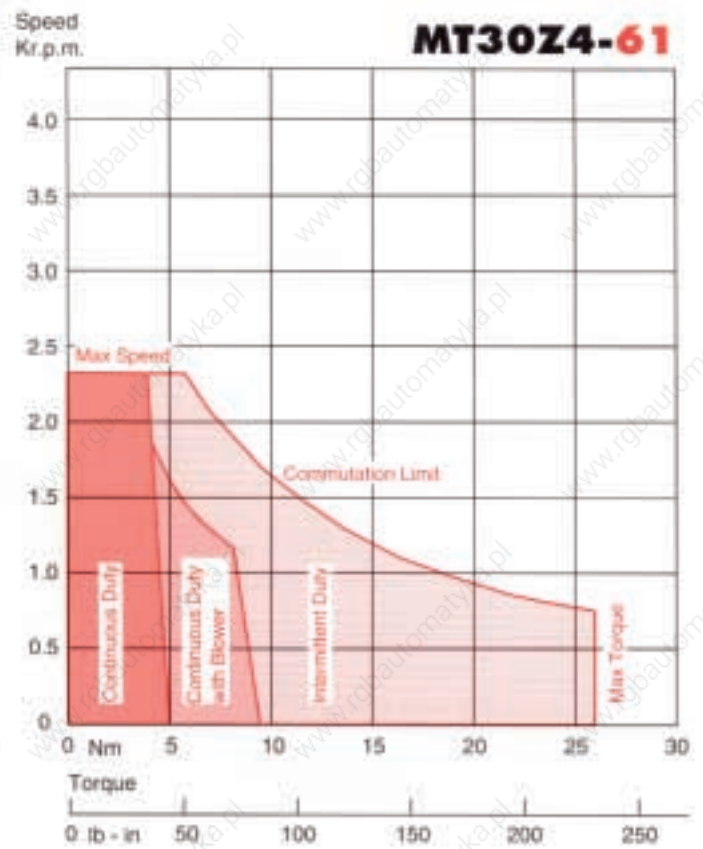
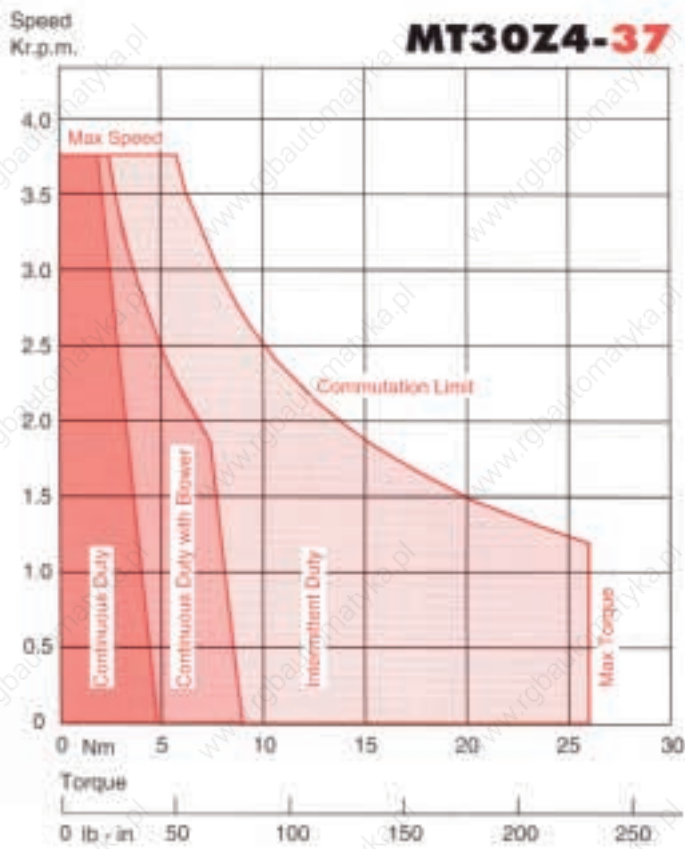

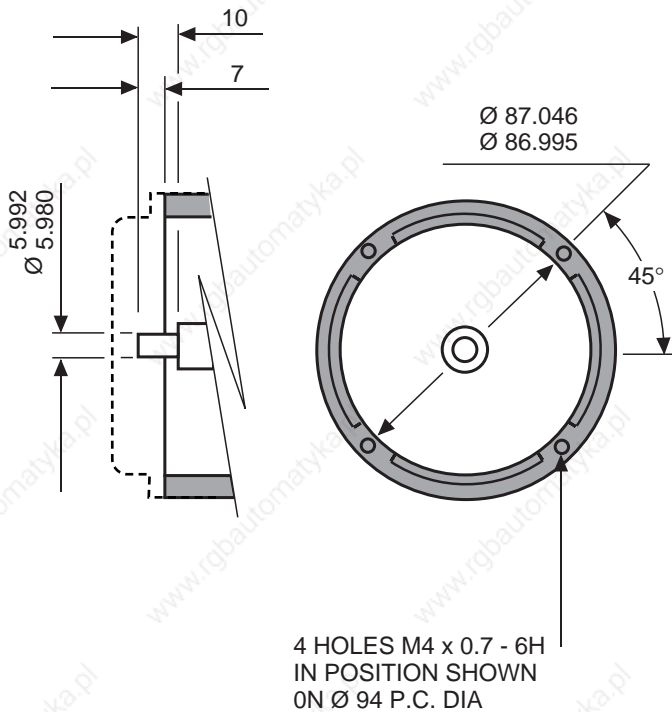

FACE & SPIGOT ARE SQUARE & CONCENTRIC TO SHAFT WITHIN 0.08 TOTAL INDICATOR READING  
(0.04 FOR OPTION R01 ONLY)

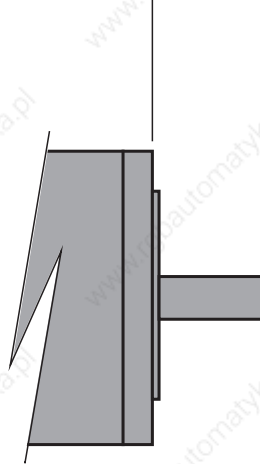

RUN OUT OF SHAFT WITHIN 0.05 TOTAL INDICATOR READING

STANDARD TOLERANCES CONFORM TO IEC72 (DIN 42955 TOLERANCE N)  
OPTION R01 CLOSE TOLERANCES CONFORM TO IEC72 PRECISION (DIN 42955 TOLERANCE R)

### NON DRIVE END SHAFT ARRANGEMENT

### DRIVE END INTERFACE TOLERANCES

DIMENSIONS IN MILLIMETRES

FOR INCH SERIES SEE DRAWING C5130/0

### SHAFT LOADING LIMITS

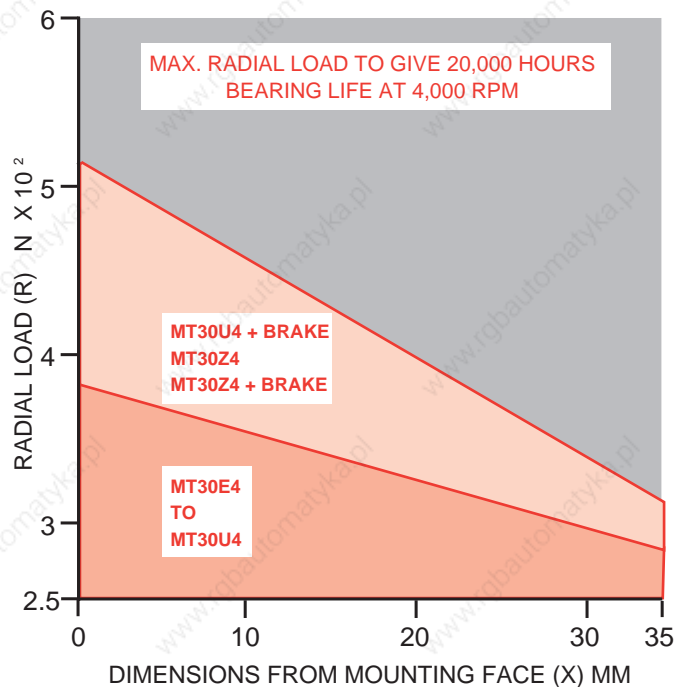
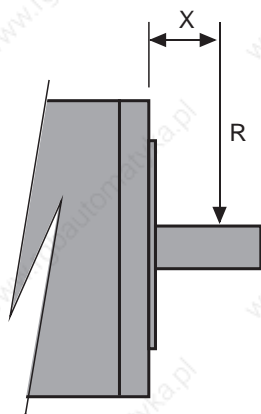

The above graph may be used as a guide for applications and includes an adequate safety factor for normal industrial use. If axial loads are to be applied, SEM should be consulted. Where radial loading in excess of the above maximum is deemed essential, the specific case should be referred to SEM.

METRIC D.C. SERVOMOTORS  
**MT30 SERIES**

**MECHANICAL DETAIL**

C5130/OM  
SHEET 1 OF 4 SHEETS

DIMENSIONS IN MILLIMETRES FOR INCH SERIES SEE DRAWING C-5130/0

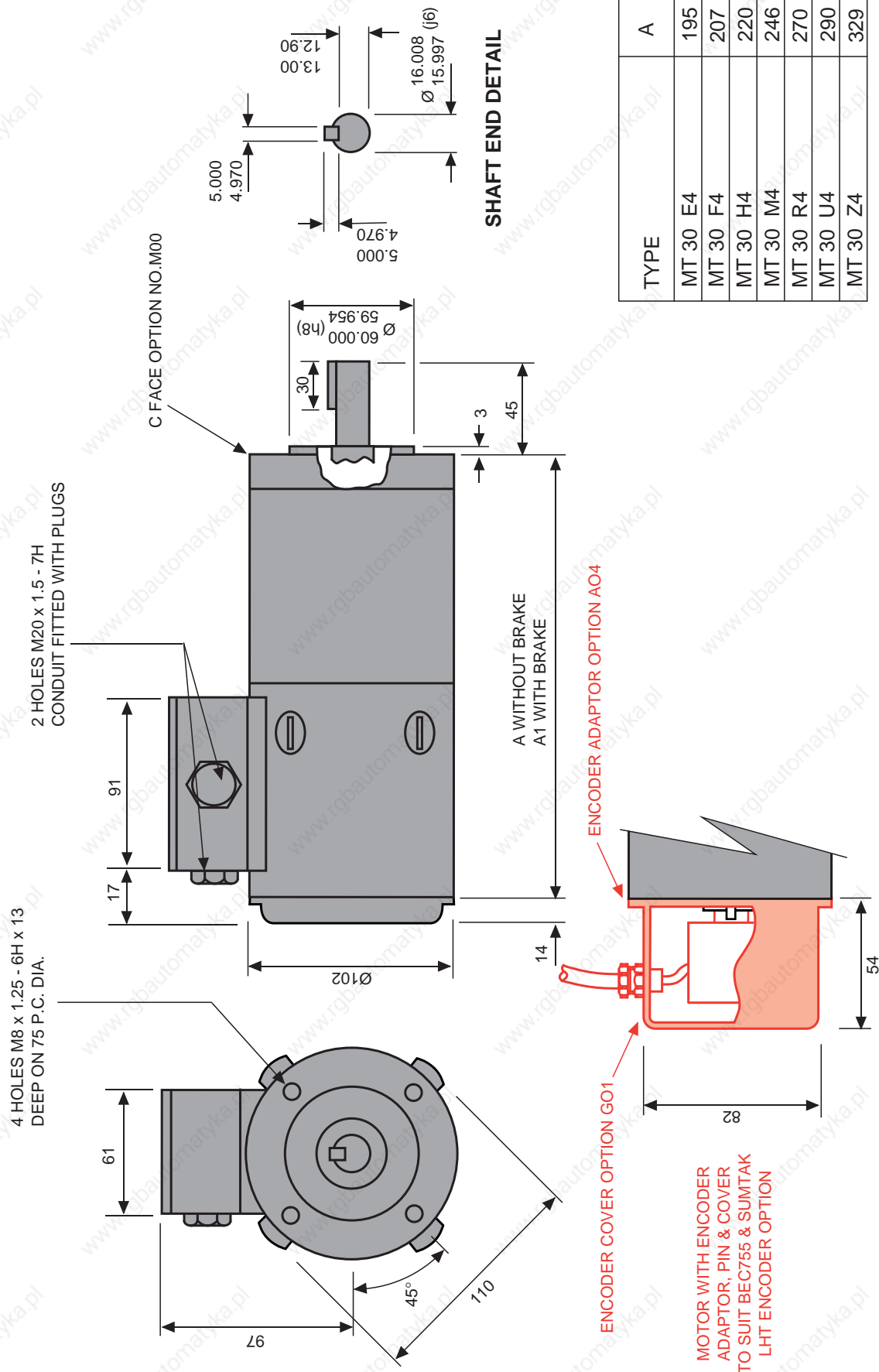

TYPE	A	A1
MT 30 E4	195	242
MT 30 F4	207	254
MT 30 H4	220	267
MT 30 M4	246	293
MT 30 R4	270	317
MT 30 U4	290	341
MT 30 Z4	329	376

METRIC D.C. SERVO MOTORS  
**MT30 SERIES**

**STANDARD MT30 SERVO MOTOR**  
WITH ADAPTOR AND COVER FOR BEC755 OR SUMTAK ENCODER SHOWN IN RED

**C5130/OM**  
SHEET 2 OF 4 SHEETS

DIMENSIONS IN MILLIMETRES FOR INCH SERIES SEE DRAWING C-5130/0

4 HOLES M8 x 1.25 - 6H x 13 DEEP ON 75 P.C. DIA.

2 HOLES M20 x 1.5 - 7H CONDUIT FITTED WITH PLUGS

C FACE OPTION NO.M00

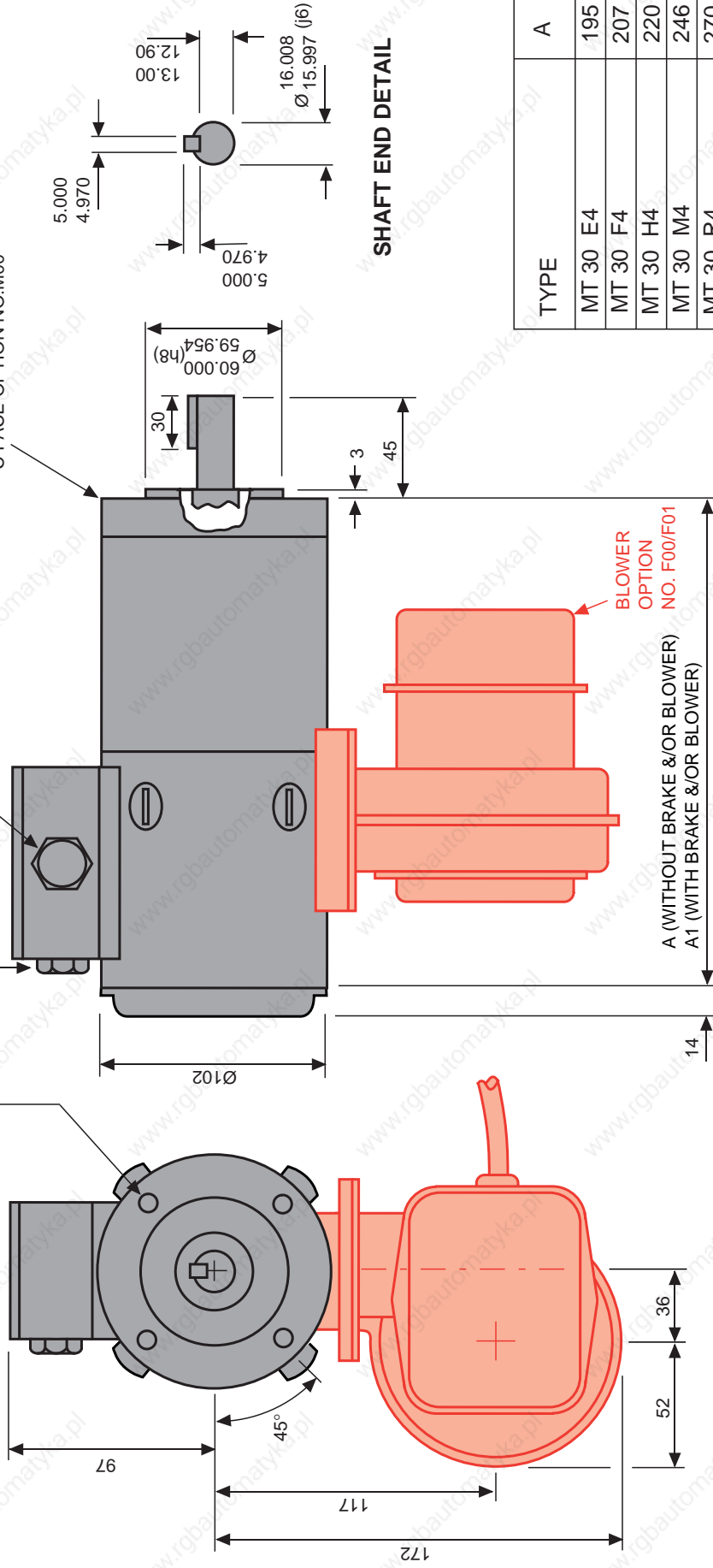

SHAFT END DETAIL

TYPE	A	A1
MT 30 E4	195	242
MT 30 F4	207	254
MT 30 H4	220	267
MT 30 M4	246	293
MT 30 R4	270	317
MT 30 U4	290	341
MT 30 Z4	329	376

BLOWER OPTION NO. F00/F01

A (WITHOUT BRAKE &/OR BLOWER)  
A1 (WITH BRAKE &/OR BLOWER)

METRIC D.C. SERVO MOTORS  
**MT30 SERIES**

**STANDARD MT30 SERVOMOTOR**  
WITH BLOWER OPTION SHOWN IN RED

**C5130/OM**  
SHEET 3 OF 4 SHEETS

DIMENSIONS IN MILLIMETRES FOR INCH SERIES SEE DRAWING C-5130/0

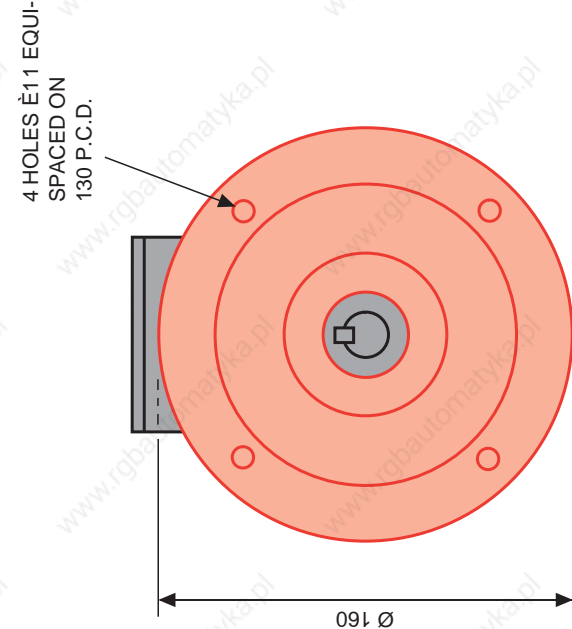
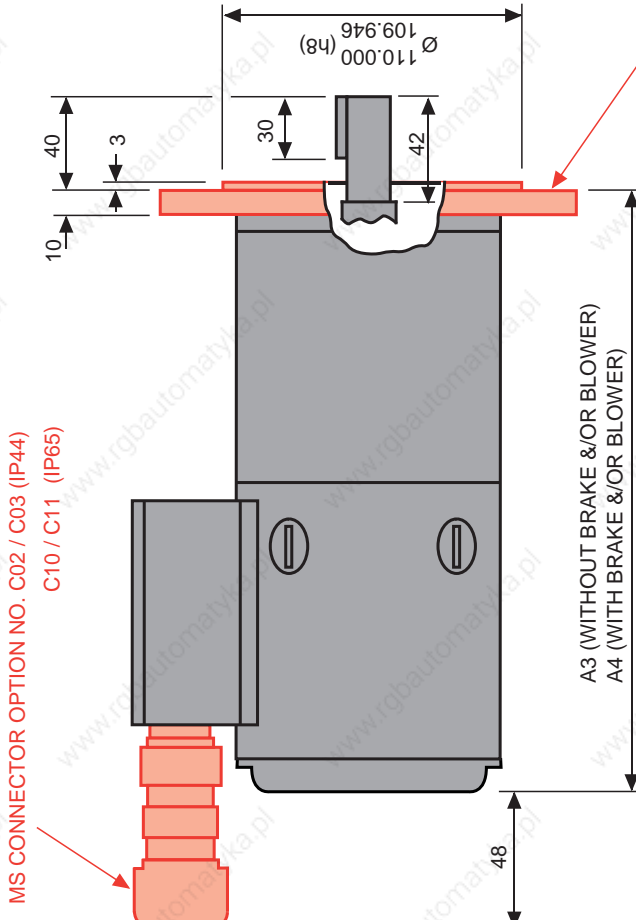

FLANGE FACE & SPIGOT ARE SQUARE & CONCENTRIC TO SHAFT WITHIN 0.2 TOTAL INDICATOR READING

TYPE	A3	A4
MT 30 E4	211	258
MT 30 F4	223	270
MT 30 H4	236	283
MT 30 M4	262	309
MT 30 R4	286	333
MT 30 U4	306	357
MT 30 Z4	345	392

METRIC D.C. SERVO MOTORS  
**MT30 SERIES**

**MT30 SERVOMOTOR**  
WITH MS CONNECTOR AND 'C' FLANGE  
OPTIONS SHOWN IN RED

**C5130/OM**  
SHEET 4 OF 4 SHEETS

Standard Features are shown by ● in black.

Available fitted options are shown in red.

Please quote No. and reference of options along with motor type No. when placing an order.

If options or features are required which are not detailed below, they may be possible, so please ask SEM sales.

NO.	REFERENCE	DESCRIPTION
<b>MECHANICAL INTERFACE</b>		
● M00	FACE	See page 29
M05	FLANGE	See page 31
R01	CLOSE TOLERANCE INTERFACE	Interface (face & shaft) to IEC72 PRECISION (DIN 42955 Tolerance R)
● S00	SHAFT	See page 29
S01	SHAFT	14mm Dia x 30mm Long
● K00	KEYWAY	See page 29
K99	NO KEYWAY	Plain Shaft
D01	SHAFT END TAPPED	M6 x 15mm Deep tapped in drive shaft
H01	HAND CRANK	Rear shaft to enable hand rotation of motor
<b>MOTOR PROTECTION</b>		
● P00	IP44/65	Enclosure protection IP44/65 as supplied. IP64/65 if shaft seal is fitted and fixing bolt holes are sealed
W01	SHAFT SEAL	Oil seal fitted at drive end/shaft interface
P99	TROPICALISED	Special treatment on internal parts
<b>BRAKES</b>		
B00	24V DC BRAKE	5 Nm torque 24V DC supply
B01	90V DC BRAKE	5 Nm torque 90V DC supply
L01	RECTIFIER	110V AC input 90V DC output for B01 Mounted inside motor terminal box (supplied loose for external mounting when motor MS Connectors are fitted)
<b>FORCED VENTILATION</b>		
V00	220V BLOWER	220 volt 50HZ single phase input
V01	110V BLOWER	110 volt 50HZ single phase input
V99	PREPARED FOR BLOWER	Motor prepared for blower but no blower fitted (covers are fitted over blower preparation)

NO.	REFERENCE	DESCRIPTION
<b>ELECTRICAL TERMINATIONS</b>		
● C00	TERMINAL BOX	With 2 x M20 tapped holes
C01	TERMINAL BOX	With 2 x PG16 tapped holes
C02	MS CONNECTOR (IP44)	Receptacle MS3102A-18-1P(10 pin) fitted to terminal box
C03	MS PLUG AND CABLE CLAMP FOR C02 (IP44)	Straight plug MS3106A-18-1S and Cable clamp 97-3057-1010-1
C09	FLYING LEADS OUT	0.5 metre long (No terminal box) radial exit
C10	MS CONNECTOR (IP65)	Receptacle MS3102E-18-1P(10 pin) fitted to terminal box
C11	MS PLUG & CABLE CLAMP FOR C10 (IP65)	Straight plug MS 3106E-18-1S (IP65)
<b>TACHOGENERATORS</b>		
T07	TACHOGENERATOR	7V/1000 RPM
● T95	TACHOGENERATOR	9.5V/1000 RPM
T19	TACHOGENERATOR	19.5V/1000 RPM
T30	TACHOGENERATOR	30V/1000 RPM
NO99	NO TACHOGENERATOR	No velocity feedback
<b>ENCODERS</b>		
E01	ENCODER	HEIDENHAIN ERN1120 Series - 250 PPR
E02	ENCODER	HEIDENHAIN ERN1120 Series - 500 PPR
E03	ENCODER	HEIDENHAIN ERN1120 Series - 1000 PPR
<b>ENCODER FITTINGS</b>		
A01	ENCODER ADAPTOR	for Heidenhain ROD 426, 436, 456, Litton G60 & Leine & Linde type 63
A02	ENCODER ADAPTOR	for Heidenhain ROD 420 & 450
A03	ENCODER ADAPTOR	for Muirhead H25E & Litton G70
A04	ENCODER ADAPTOR	for BEC 755
A05	ENCODER ADAPTOR	for Tamagawa TS5300 series
A06	ADAPTOR	for Size 11 resolver
A10	SYNCHRO CLAMPS	for A01, A03 and A06
G01	ENCODER COVER	Cast cover with 1 X M10 tapped hole, and cable gland for A04 only
G02	ENCODER COVER (IP65)	Cast cover with 1 X PG7 tapped hole, and cable gland for A04 only
G03	ENCODER COVER (IP44)	Cast cover with MS receptacle MS3102A-18-1P, for A04 only
G07	ENCODER COVER (IP65)	Cast cover with 2 x axial exit cable glands for A05 & A06 only
G15	ENCODER COVER (IP65)	Cast cover with MS receptacle MS 3102E-18-1P for A04 only (IP65)
C05	MS PLUG AND CABLE CLAMP FOR G03 (IP44)	Straight plug MS3106A-18-1S Cable clamp 97-3057-1010-1 (IP44)
C11	MS PLUG & CABLE CLAMP FOR G15 (IP65)	Straight plug MS3106E-18-1S & cable clamp (IP65)

# MT40P4 D.C. Servomotors

## Technical Data

Parameter	Unit	MT40P4-76	MT40P4-61	MT40P4-38
<b>GENERAL</b>				
Voltage Gradient No Load	Volts/1000RPM*	76	61	38
Max. Terminal Voltage	Volts	180	180	150
Max. Speed	RPM	2400	3000	4000
<b>Continuous Stall Torque TENV***</b>	<b>Nm</b>	<b>6.0</b>	<b>6.0</b>	<b>6.0</b>
	<b>lb - in</b>	<b>53</b>	<b>53</b>	<b>53</b>
Continuous Stall Torque Blower Cooled***	Nm	12.0	12.0	12.0
	lb - in	106	106	106
<b>Continuous Stall Current TENV***</b>	<b>Amps</b>	<b>8.7</b>	<b>11.0</b>	<b>17.0</b>
Armature Polar Moment of Inertia	Kgm <sup>2</sup>	0.0077	0.0077	0.0077
	lb - in Sec <sup>2</sup>	0.068	0.068	0.068
<b>Torque Constant KT**</b>	<b>Nm/Amp*</b>	<b>0.69</b>	<b>0.55</b>	<b>0.35</b>
	<b>lb - in/Amp*</b>	<b>6.1</b>	<b>4.9</b>	<b>3.1</b>
Voltage Constant KV**	Volts Sec Rad <sup>-1*</sup>	0.69	0.55	0.345
Peak Stall Torque**	Nm	34.0	34.0	34.0
	lb - in	300	300	300
Current at Peak Torque**	Amps	50.0	63.0	100.0
Theoretical Acceleration at Peak Torque	Rad/Sec <sup>2</sup>	4400	4400	4400
<b>Winding</b>				
Armature Resistance Less Brushes**	Ohms*	1.0	0.6	0.25
Armature Inductance	Millihenrys*	4.5	3.0	1.2
Mechanical Time Constant**	Milliseconds	19.0	18.0	20.0
<b>Thermal</b>				
Insulation Class		H	H	H
Max. Ambient Temperature	°C	40	40	40
Thermal Time Constant	Minutes*	90	90	90
<b>Mechanical</b>				
Static Friction Torque	Nm	0.23	0.23	0.23
	lb - in	2.0	2.0	2.0
Motor Weight	Kg	17.5	17.5	17.5
	lb	38.5	38.5	38.5
<b>TACHOMETER</b>				
		STANDARD FOR USA ONLY		
Voltage Gradient	Volts/1000RPM*	9.5	7	
	Volts Sec Rad <sup>-1*</sup>	0.090	0.067	
Ripple	Per Cent	1.0	1.0	
	Cycles/Rev	25	25	
Armature Resistance**	Ohms	36	24	
Armature Inductance	Millihenrys*	55	36	
Maximum Current	Amps	0.025	0.035	

- \* Tolerance Plus or Minus 10%
- \*\* At 25°C
- \*\*\* At 40°C Ambient

■ **Motor Performance** data is on the basis of a pure D.C. i.e. unity system form factor supply. Appropriate performance derating is necessary when using a supply with a system form factor greater than unity.

■ **Commutation Curves** opposite and peak torque are based on the **peak value** of the current wave form. For a form factor greater than unity the maximum torque permitted will be lower than that detailed on the performance curves. **IMPORTANT** The commutation curves are based on a load inertia equal to the motor inertia. Advice should be taken in the event the load inertia is greater than the motor inertia.

● **Heatsink Ratings** Torque ratings shown in brackets (opposite top right) are correct for motors when fitted to a heatsink size (450mm x 450mm x 20mm)  
(18" x 18" x 0.8")

**STALL TORQUE 6.0Nm / 53lb-in**

**● (6.8Nm / 60lb-in)**

## Performance Curves

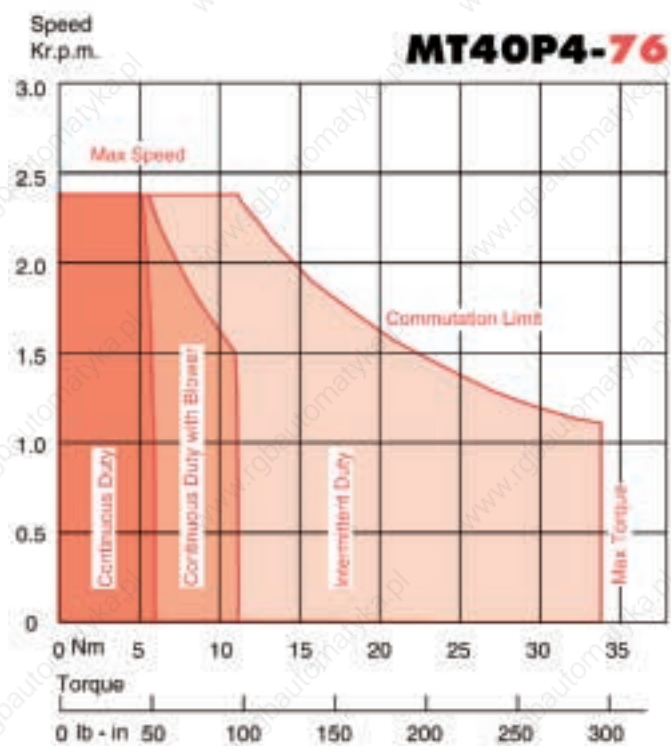
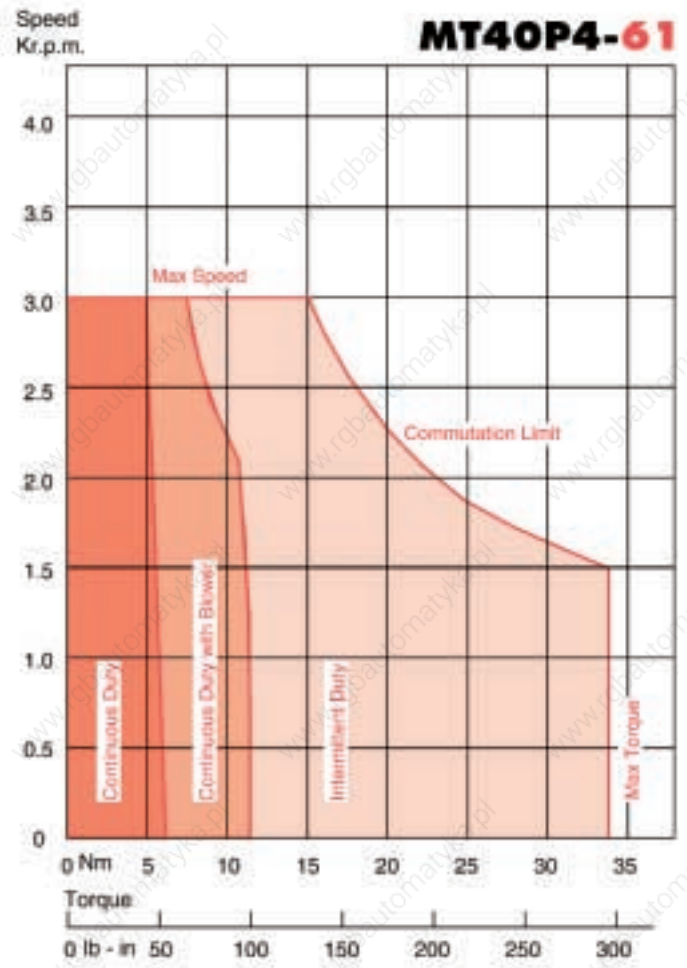
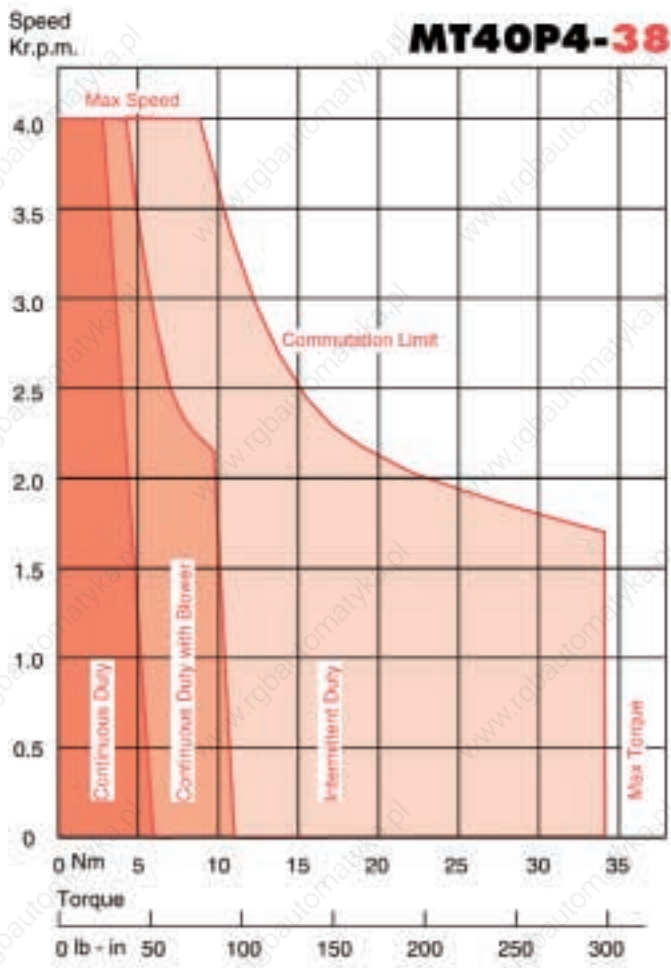

# MT40W4 D.C. Servomotors

## Technical Data

Parameter	Unit	MT40W4-90	MT40W4-68	MT40W4-45
<b>GENERAL</b>				
Voltage Gradient No Load	Volts/1000RPM*	90	68	45
Max. Terminal Voltage	Volts	180	180	180
Max. Speed	RPM	2000	2600	4000
<b>Continuous Stall Torque TENV***</b>	<b>Nm</b>	<b>8.5</b>	<b>8.5</b>	<b>8.5</b>
	<b>lb - in</b>	<b>75</b>	<b>75</b>	<b>75</b>
Continuous Stall Torque Blower Cooled***	Nm	16.0	16.0	16.0
	lb - in	140	140	140
<b>Continuous Stall Current TENV***</b>	<b>Amps</b>	<b>10.0</b>	<b>13.0</b>	<b>20.0</b>
Armature Polar Moment of Inertia	Kgm <sup>2</sup>	0.011	0.011	0.011
	lb - in Sec <sup>2</sup>	0.094	0.094	0.094
<b>Torque Constant KT**</b>	<b>Nm/Amp*</b>	<b>0.85</b>	<b>0.64</b>	<b>0.42</b>
	<b>lb - in/Amp*</b>	<b>7.5</b>	<b>5.7</b>	<b>3.7</b>
Voltage Constant KV**	Volts Sec Rad <sup>-1*</sup>	0.85	0.64	0.42
Peak Stall Torque**	Nm	50	50	50
	lb - in	440	440	440
Current at Peak Torque**	Amps	65	86	130
Theoretical Acceleration at Peak Torque	Rad/Sec <sup>2</sup>	4500	4500	4500
<b>Winding</b>				
Armature Resistance Less Brushes**	Ohms*	0.80	0.47	0.20
Armature Inductance	Millihenrys*	6.0	3.3	1.2
Mechanical Time Constant**	Milliseconds	14.0	17.0	17.0
<b>Thermal</b>				
Insulation Class		H	H	H
Max. Ambient Temperature	°C	40	40	40
Thermal Time Constant	Minutes*	100	100	100
<b>Mechanical</b>				
Static Friction Torque	Nm	0.23	0.23	0.23
	lb - in	2.0	2.0	2.0
Motor Weight	Kg	21.5	21.5	21.5
	lb	47	47	47
<b>TACHOMETER</b>				
		STANDARD FOR USA ONLY		
Voltage Gradient	Volts/1000RPM*	9.5	7	
	Volts Sec Rad <sup>-1*</sup>	0.090	0.067	
Ripple	Per Cent	1.0	1.0	
	Cycles/Rev	25	25	
Armature Resistance**	Ohms	36	24	
Armature Inductance	Millihenrys*	55	36	
Maximum Current	Amps	0.025	0.035	

\* Tolerance Plus or Minus 10%

\*\* At 25°C

\*\*\* At 40°C Ambient

■ **Motor Performance** data is on the basis of a pure D.C. i.e. unity system form factor supply. Appropriate performance derating is necessary when using a supply with a system form factor greater than unity.

■ **Commutation Curves** opposite and peak torque are based on the **peak value** of the current wave form. For a form factor greater than unity the maximum torque permitted will be lower than that detailed on the performance curves. **IMPORTANT** The commutation curves are based on a load inertia equal to the motor inertia. Advice should be taken in the event the load inertia is greater than the motor inertia.

● **Heatsink Ratings** Torque ratings shown in brackets (opposite top right) are correct for motors when fitted to a heatsink size (450mm x 450mm x 20mm)  
(18" x 18" x 0.8")

**STALL TORQUE 8.5Nm / 75lb-in**

**● (10.0Nm / 88.5lb-in)**

## Performance Curves

Speed  
Kr.p.m. **MT40W4-45**

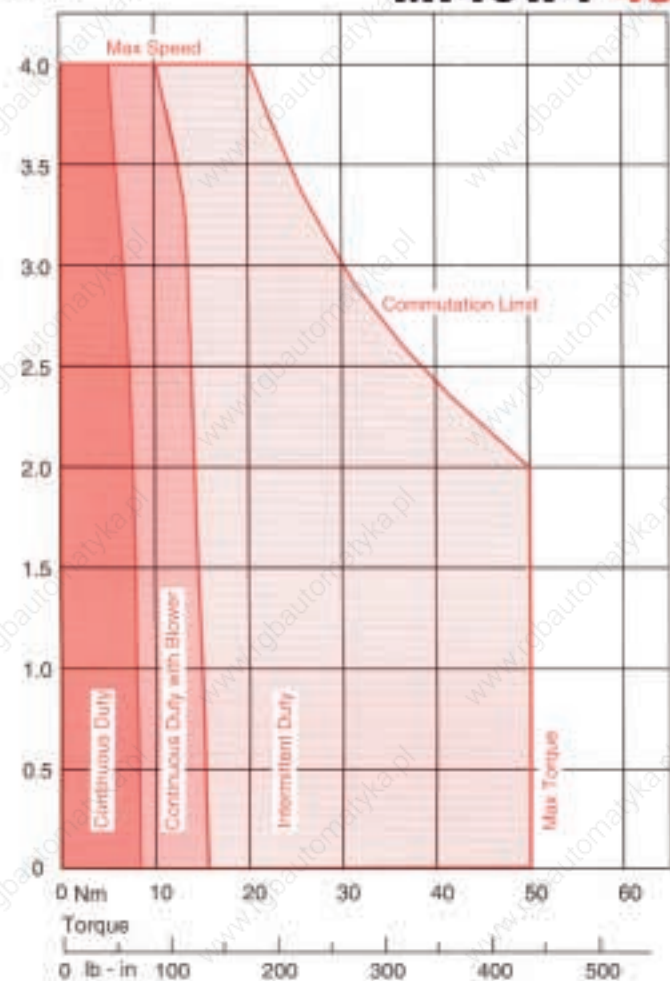

Speed  
Kr.p.m. **MT40W4-68**

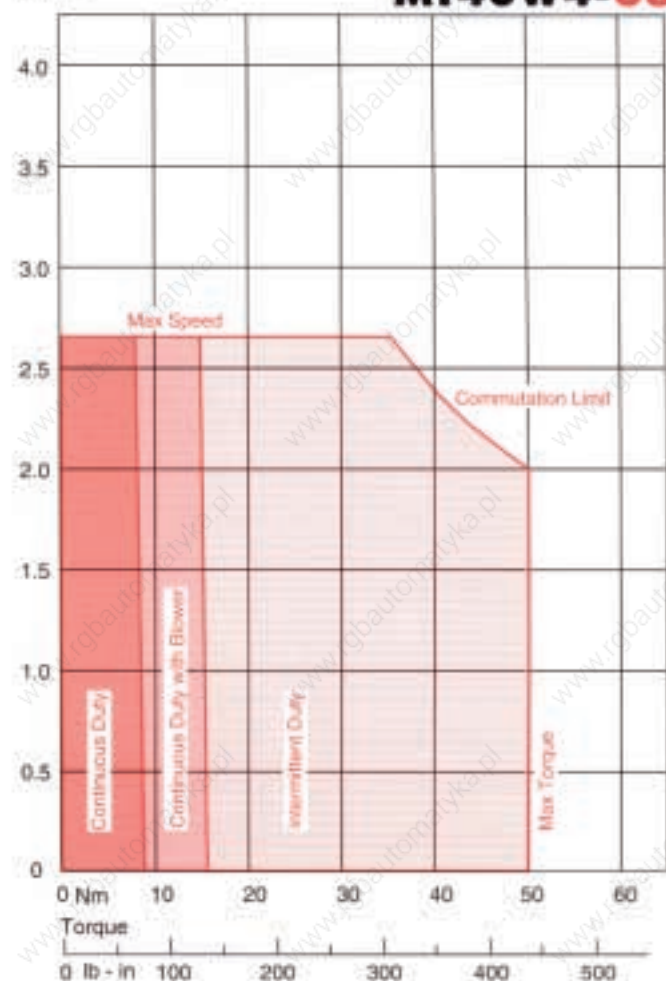

Speed  
Kr.p.m. **MT40W4-90**

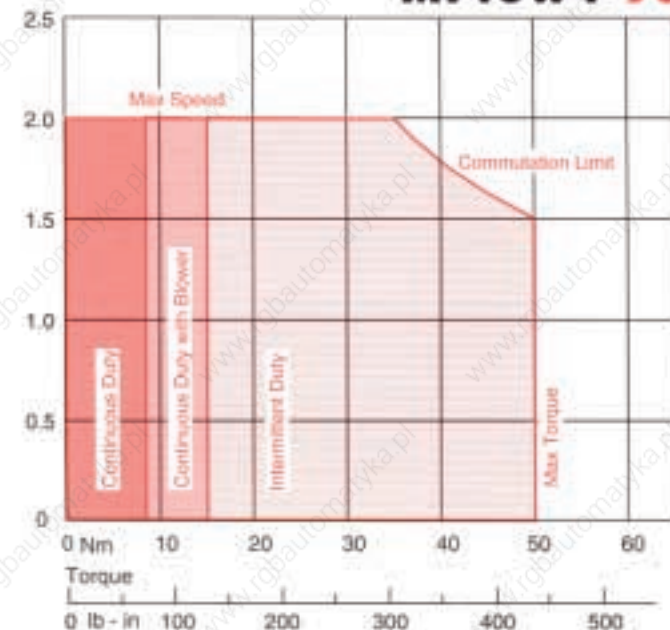

# MT40ZD4 D.C. Servomotors

## Technical Data

Parameter	Unit	MT40ZD4-90	MT40ZD4-60	MT40ZD4-45
<b>GENERAL</b>				
Voltage Gradient No Load	Volts/1000RPM*	90	60	45
Max. Terminal Voltage	Volts	180	180	180
Max. Speed	RPM	2000	3000	4000
<b>Continuous Stall Torque TENV***</b>	<b>Nm</b>	<b>11.0</b>	<b>11.0</b>	<b>11.0</b>
	<b>lb - in</b>	<b>97</b>	<b>97</b>	<b>97</b>
Continuous Stall Torque Blower Cooled***	Nm	21.0	21.0	21.0
	lb - in	185	185	185
<b>Continuous Stall Current TENV***</b>	<b>Amps</b>	<b>13.5</b>	<b>20.0</b>	<b>26.0</b>
Armature Polar Moment of Inertia	Kgm <sup>2</sup>	0.014	0.014	0.014
	lb - Sec <sup>2</sup>	0.13	0.13	0.13
<b>Torque Constant KT**</b>	<b>Nm/Amp*</b>	<b>0.82</b>	<b>0.55</b>	<b>0.41</b>
	<b>lb - in/Amp*</b>	<b>7.5</b>	<b>4.8</b>	<b>3.6</b>
Voltage Constant KV**	Volts Sec Rad <sup>-1*</sup>	0.85	0.55	0.41
Peak Stall Torque**	Nm	66	66	66
	lb - in	580	580	580
Current at Peak Torque**	Amps	85	125	170
Theoretical Acceleration at Peak Torque	Rad/Sec <sup>2</sup>	4700	4700	4700
<b>Winding</b>				
Armature Resistance Less Brushes**	Ohms*	0.56	0.25	0.15
Armature Inductance	Millihenrys*	4.0	1.8	1.0
Mechanical Time Constant**	Milliseconds	14.0	16.0	17.0
<b>Thermal</b>				
Insulation Class		H	H	H
Max. Ambient Temperature	°C	40	40	40
Thermal Time Constant	Minutes*	100	100	100
<b>Mechanical</b>				
Static Friction Torque	Nm	0.25	0.25	0.25
	lb - in	2.2	2.2	2.2
Motor Weight	Kg	26.0	26.0	26.0
	lb	57	57	57
<b>TACHOMETER</b>				
		STANDARD FOR USA ONLY		
Voltage Gradient	Volts/1000RPM*	9.5	7	
	Volts Sec Rad <sup>-1*</sup>	0.090	0.067	
Ripple	Per Cent	1.0	1.0	
	Cycles/Rev	25	25	
Armature Resistance**	Ohms	36	24	
Armature Inductance	Millihenrys*	55	36	
Maximum Current	Amps	0.025	0.035	

- \* Tolerance Plus or Minus 10%
- \*\* At 25°C
- \*\*\* At 40°C Ambient

■ **Motor Performance** data is on the basis of a pure D.C. i.e. unity system form factor supply. Appropriate performance derating is necessary when using a supply with a system form factor greater than unity.

■ **Commutation Curves** opposite and peak torque are based on the **peak value** of the current wave form. For a form factor greater than unity the maximum torque permitted will be lower than that detailed on the performance curves. **IMPORTANT** The commutation curves are based on a load inertia equal to the motor inertia. Advice should be taken in the event the load inertia is greater than the motor inertia.

● **Heatsink Ratings** Torque ratings shown in brackets (opposite top right) are correct for motors when fitted to a heatsink size (450mm x 450mm x 20mm)  
(18" x 18" x 0.8")

**STALL TORQUE 11.0Nm / 97lb-in**

**● (12.0Nm / 106lb-in)**

## Performance Curves

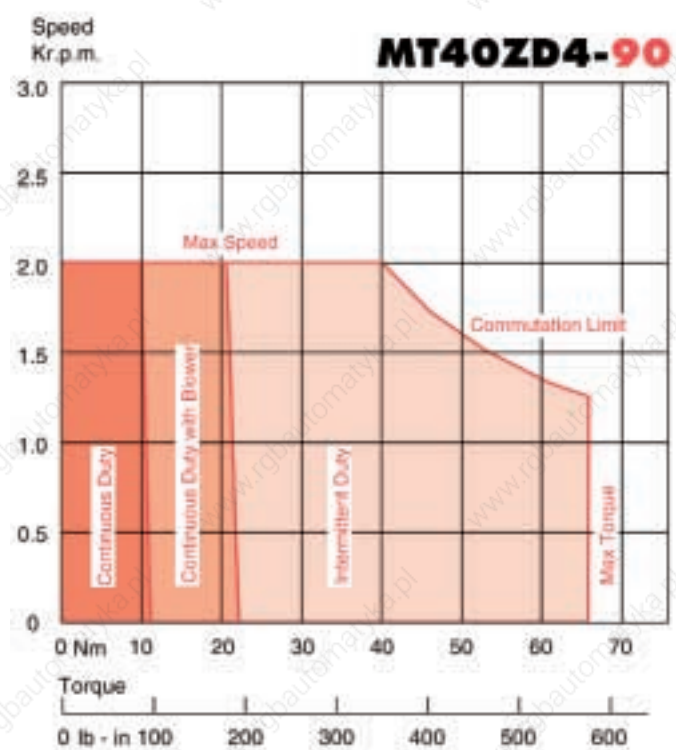
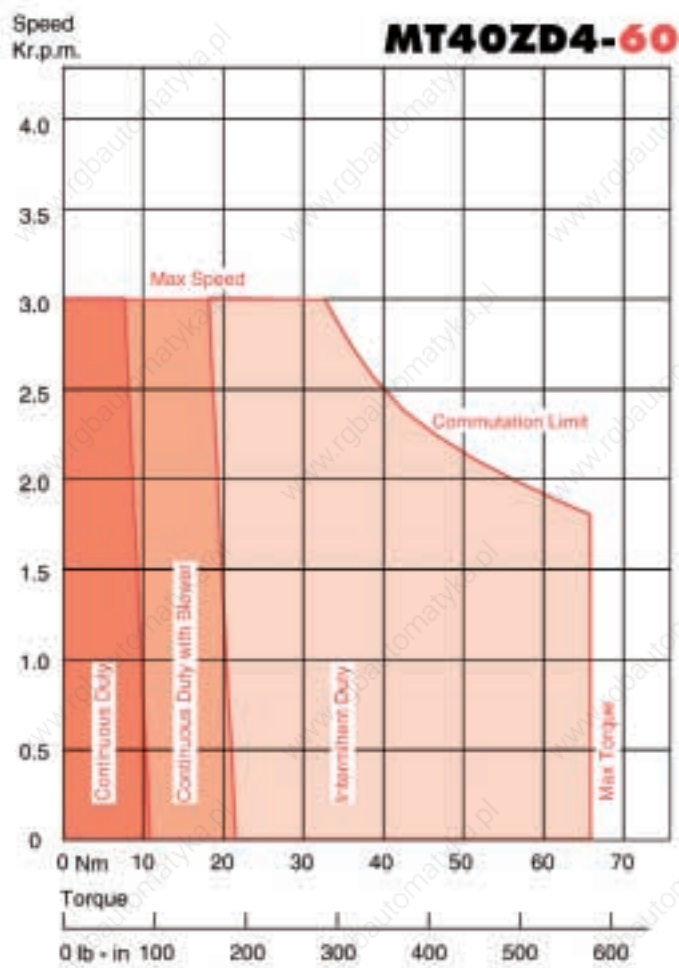
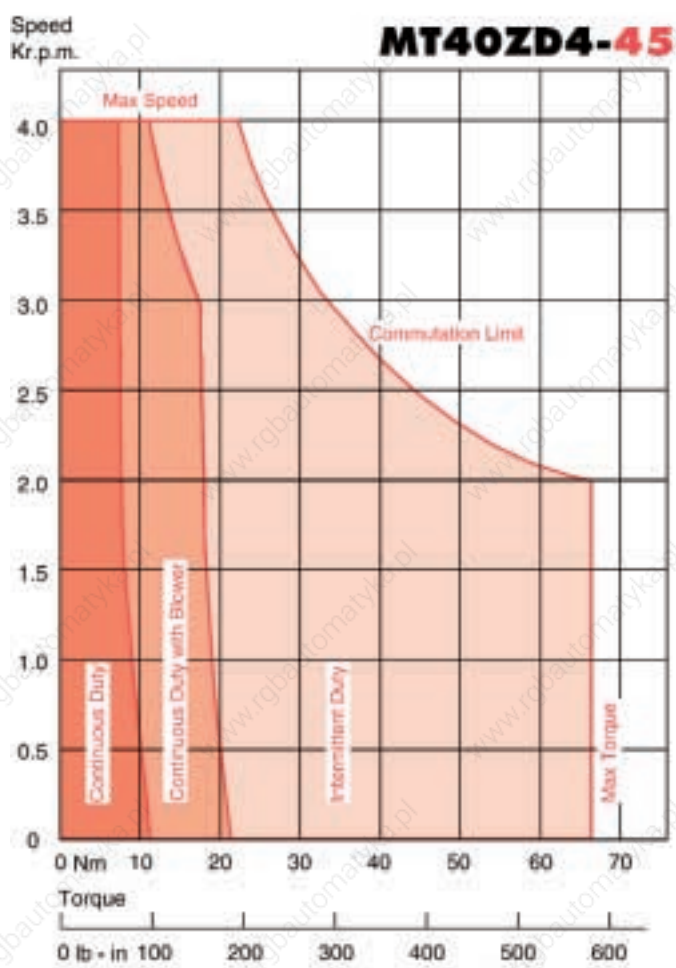

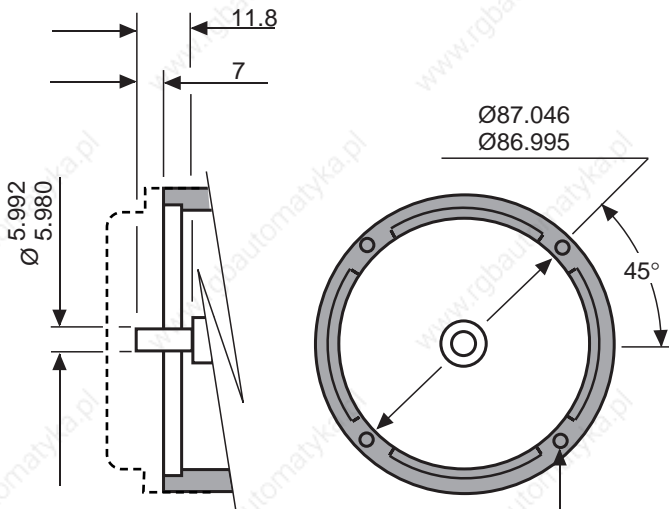

4 HOLES M4 x 0.7 - 6H  
IN POSITION SHOWN  
ON Ø 94 P.C. DIA

**NON DRIVE END SHAFT ARRANGEMENT**

FACE & SPIGOT ARE SQUARE & CONCENTRIC TO  
SHAFT WITHIN 0.10 TOTAL INDICATOR READING  
(0.05 FOR OPTION R01 ONLY)

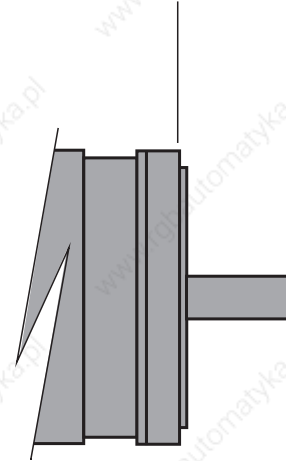

RUN OUT OF SHAFT WITHIN  
0.05 TOTAL INDICATOR READING

STANDARD TOLERANCES CONFORM TO  
IEC72 (DIN 42955 TOLERANCE N)  
OPTION R01 CLOSE TOLERANCES CONFORM TO  
IEC72 PRECISION (DIN 42955 TOLERANCE R)

**DRIVE END INTERFACE TOLERANCES**

DIMENSIONS IN MILLIMETRES FOR INCH SERIES SEE DRAWING C5240/0

**SHAFT LOADING LIMITS**

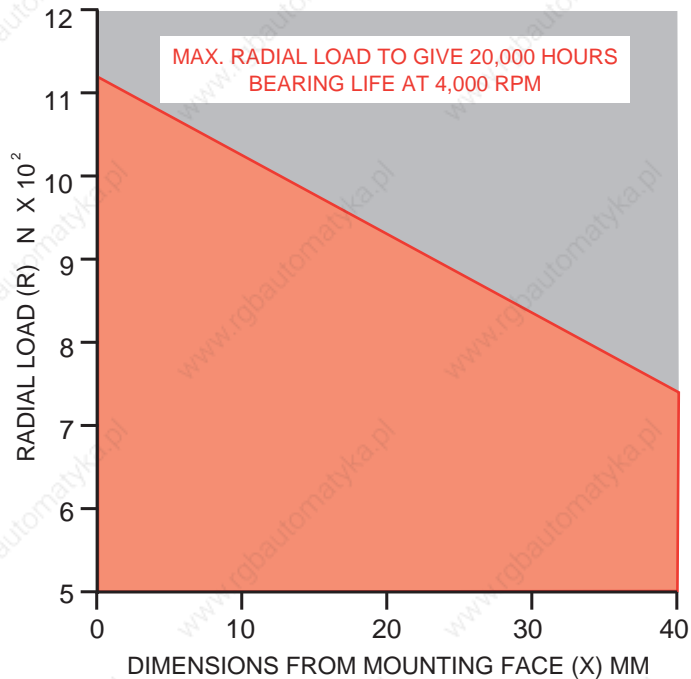
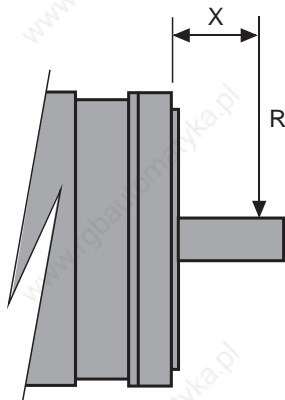

The above graph may be used as a guide for applications and includes an adequate safety factor for normal industrial use. If axial loads are to be applied, SEM should be consulted. Where radial loading in excess of the above maximum is deemed essential, the specific case should be referred to SEM.

METRIC D.C. SERVOMOTORS  
**MT40 SERIES**

**MECHANICAL DETAIL**

**C5240/OM**  
SHEET 1 OF 4 SHEETS

DIMENSIONS IN MILLIMETRES FOR INCH SERIES SEE DRAWING C-5240/0

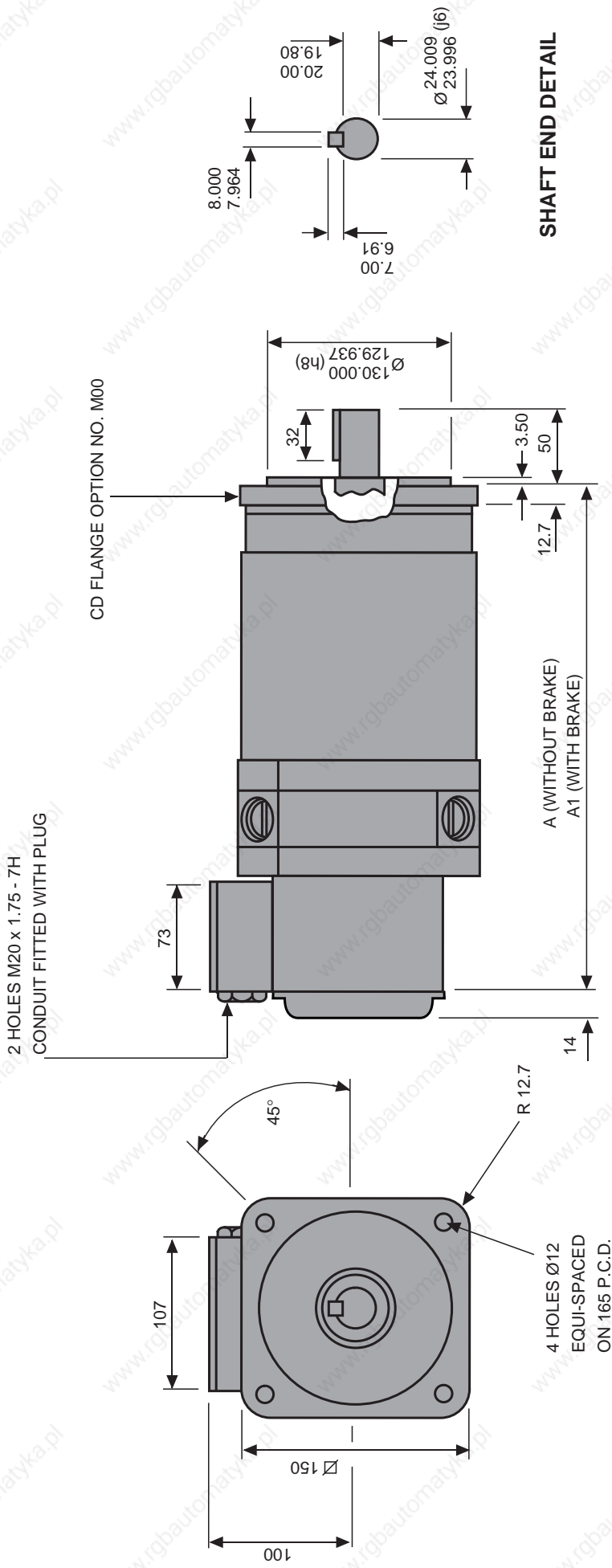

**SHAFT END DETAIL**

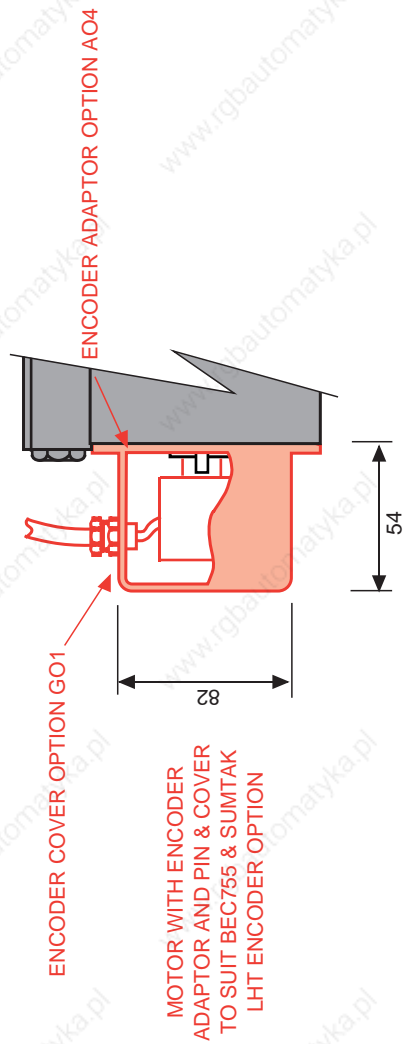

TYPE	A	A1
MT 40 P4	337	382
MT 40 W4	382	427
MT 40 ZD4	427	472

METRIC D.C. SERVO MOTORS  
**MT40 SERIES**

**STANDARD MT40 SERVOMOTOR**

**C5240/OM**  
SHEET 2 OF 4 SHEETS

DIMENSIONS IN MILLIMETRES FOR INCH SERIES SEE DRAWING C-5240/0

2 HOLES M20 x 1.75 - 7H  
CONDUIT FITTED WITH PLUG

CD FLANGE OPTION NO. M00

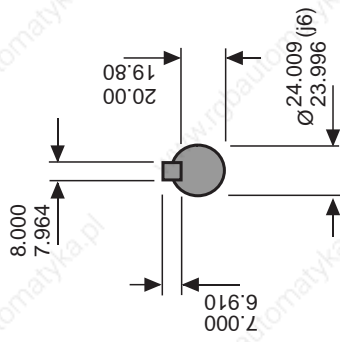
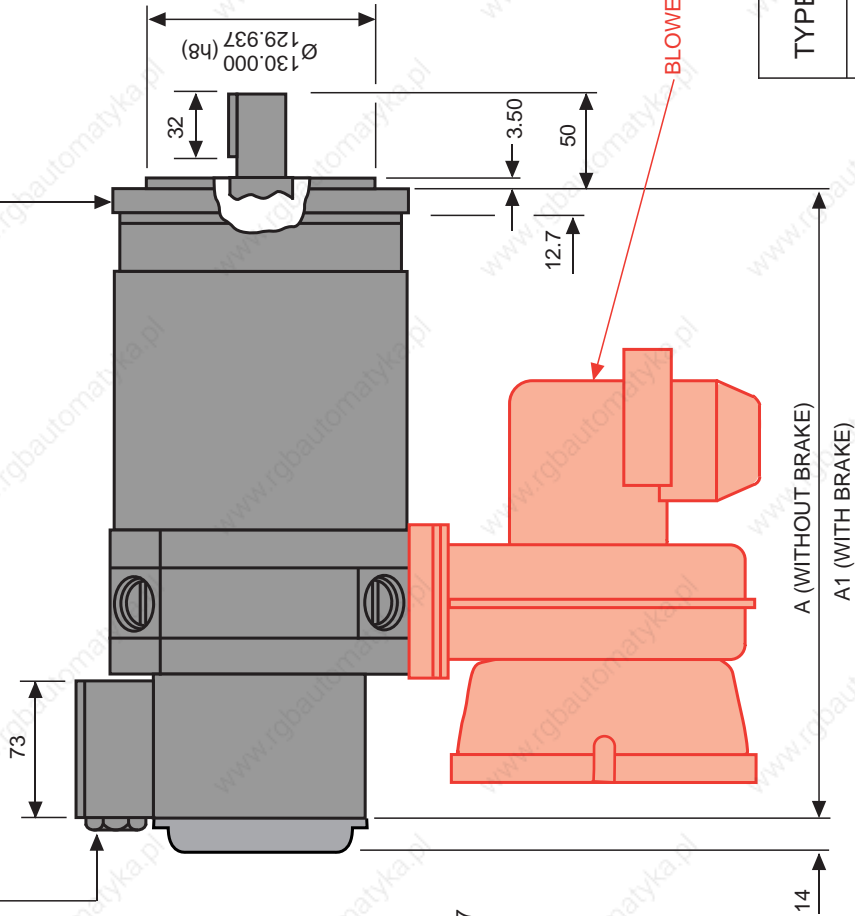
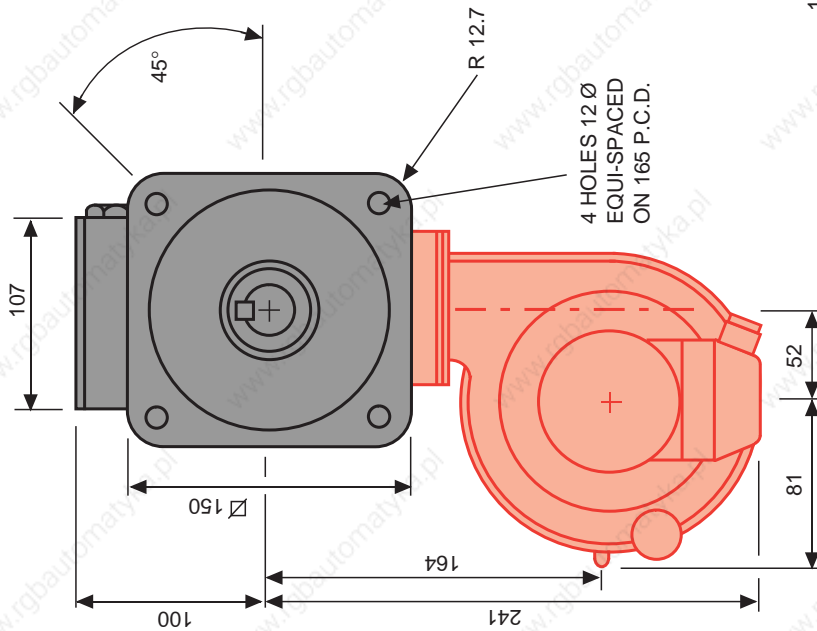

SHAFT END DETAIL

BLOWER OPTION NO. F00/F01

TYPE	A	A1
MT 40 P4	337	382
MT 40 W4	382	427
MT 40 ZD4	427	472

METRIC D.C. SERVOMOTORS  
**MT40 SERIES**

**MT40 SERVOMOTOR**  
WITH BLOWER OPTION SHOWN IN RED

**C5240/OM**  
SHEET 3 OF 4 SHEETS

DIMENSIONS IN MILLIMETRES FOR INCH SERIES SEE DRAWING C-5240/0

MS CONNECTOR OPTION NO. C02 / C03 (IP44)  
C10 / C11 (IP65)

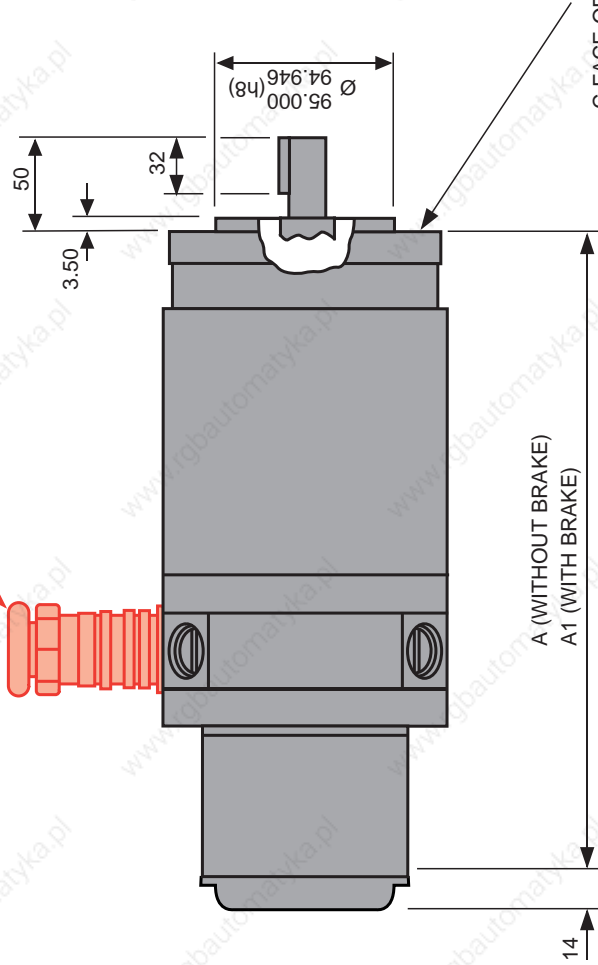
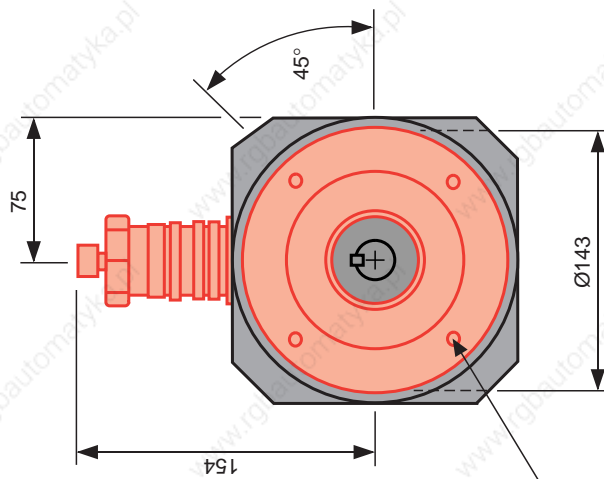

C FACE OPTION NO. M02

4 HOLES M8 x 1.25 - 6H  
EQUI-SPACED ON 115 P.C.D.  
MAX. DEPTH 16

TYPE	A	A1
MT 40 P4	337	382
MT 40 W4	382	427
MT 40 ZD4	427	472

METRIC D.C. SERVOMOTORS  
**MT40 SERIES**

**MT40 SERVOMOTOR**  
WITH MS CONNECTOR AND 'C' FACE OPTIONS SHOWN IN RED

**C5240/OM**  
SHEET 4 OF 4 SHEETS

Standard features are shown by ● in black.

Available fitted options are shown in red.

Please quote No. and reference of option along with motor type No. when placing an order.

If options or features are required which are not detailed below, they may be possible, so please ask SEM sales.

NO.	REFERENCE	DESCRIPTION
<b>MECHANICAL INTERFACE</b>		
● M00	FLANGE	See page 41
M02	FACE	See page 43
R01	CLOSE TOLERANCE INTERFACE	Interface (face & shaft) to IEC72 PRECISION (DIN 42955 Tolerance R)
● S00	SHAFT	See page 41
● K00	KEYWAY	See page 41
K99	NO KEYWAY	Plain shaft
D01	SHAFT END TAPPED	M8 x 15mm Deep tapped in drive shaft
H01	HAND CRANK	Rear shaft to enable hand rotation of motor
<b>MOTOR PROTECTION</b>		
● P00	IP44/65 PROTECTION	Enclosure protection IP44 at shaft. IP65 for remainder of motor. IP64/65 if option W01 shaft seal is fitted
W01	SHAFT SEAL	Oil seal fitted at drive end/shaft interface
P99	TROPICALISED	Special treatment on internal parts
<b>BRAKES</b>		
B00	24V DC BRAKE	18 Nm torque 24V DC supply
B01	90V DC BRAKE	18 Nm torque 90V DC supply
L01	RECTIFIER	110V AC input 90V DC output for B01 mounted inside motor terminal box (supplied loose for external mounting when motor MS Connectors are fitted)
<b>FORCED VENTILATION</b>		
V00	220V BLOWER	220 volt 50HZ single phase input
V01	110V BLOWER	110 volt 50HZ single phase input
V99	PREPARED FOR BLOWER	Motor prepared for blower but no blower fitted (covers are fitted over blower preparation)

NO.	REFERENCE	DESCRIPTION
<b>ELECTRICAL TERMINATIONS</b>		
● C00	TERMINAL BOX	With 2 x M20 tapped holes
C01	TERMINAL BOX	With 2 X PG16 tapped holes
C02	MS CONNECTOR (IP44)	Receptacle MS3102A-24-11P(9 pin) fitted to motor (IP44)
C03	MS PLUG AND CABLE CLAMP FOR C02 (IP44)	Straight plug MS3106A-24-11S and Cable clamp 97-3057-1016-12 (IP44)
C09	FLYING LEADS OUT	0.5 metre long (No terminal box radial exit)
C10	MS CONNECTOR (IP65)	Receptacle MS 3102E-24-11P (9 pin) fitted to motor (IP65)
C11	MS PLUG (IP65)	Straight plug MS 3106E-24-11S (IP65)
<b>TACHOGENERATORS</b>		
T07	TACHOGENERATOR	7V/1000 RPM
● T95	TACHOGENERATOR	9.5V/1000 RPM
T19	TACHOGENERATOR	19.5V/1000 RPM
T30	TACHOGENERATOR	30V/1000 RPM
N99	NO TACHOGENERATOR	No velocity feedback
<b>ENCODERS</b>		
E01	ENCODER	HEIDENHAIN ERN1120 Series - 250 PPR
E02	ENCODER	HEIDENHAIN ERN1120 Series - 500 PPR
E03	ENCODER	HEIDENHAIN ERN1120 Series 1000 PPR
<b>ENCODER FITTINGS</b>		
A01	ENCODER ADAPTOR	for Heidenhain ROD 426, 436, 456, Litton G60 & Leine & Linde type 63
A02	ENCODER ADAPTOR	for Heidenhain ROD 420 & 450
A03	ENCODER ADAPTOR	for Muirhead H25E & Litton G70
A04	ENCODER ADAPTOR	for BEC 755 & SUMTAK model LHT
A05	ENCODER ADAPTOR	for Tamagawa TS5300 series
A06	ADAPTOR	for Size 11 resolver
A10	SYNCHRO CLAMPS	for A01, A03 and A06
G01	ENCODER COVER	Cast cover with 1 X M10 tapped hole, and cable gland for A04 only
G02	ENCODER COVER (IP65)	Cast cover with 1 X PG7 tapped hole, and cable gland for A04 only
G03	ENCODER COVER (IP44)	Cast cover with MS receptacle MS3102A-18-1P, for A04 only
G07	ENCODER COVER (IP65)	Cast cover with 2 x axial exit cable glands for A05 & A06 only
G15	ENCODER COVER (IP65)	Cast cover with MS receptacle MS 3102E-18-1P for A04 only (IP65)
C05	MS PLUG AND CABLE CLAMP FOR G03 (IP44)	Straight plug MS3106A-18-1S (IP44) Cable clamp 97-3057-1010-1
C27	MS PLUG & CABLE CLAMP FOR G15 (IP65)	Straight plug MS3106E-18-1S (IP65)

# MT52K8 D.C. Servomotors

## Technical Data

Parameter	Unit	MT52K8-87	MT52K8-62	MT52K8-50	MT52K8-37
<b>GENERAL</b>					
Voltage Gradient No Load	Volts/1000RPM*	87	62	50	37
Max. Terminal Voltage	Volts	130	130	130	130
Max. Speed	RPM	1500	2100	2600	3500
<b>Continuous Stall Torque TENV***</b>	<b>Nm</b>	<b>8.0</b>	<b>8.0</b>	<b>8.0</b>	<b>8.0</b>
	<b>lb - in</b>	<b>70</b>	<b>70</b>	<b>70</b>	<b>70</b>
Continuous Stall Torque Blower Cooled***	Nm	16	16	16	16
	lb - in	140	140	140	140
<b>Continuous Stall Current TENV***</b>	<b>Amps</b>	<b>9.7</b>	<b>13.5</b>	<b>17.0</b>	<b>22.8</b>
Armature Polar Moment of Inertia	Kgm <sup>2</sup>	0.013	0.013	0.013	0.013
	lb - in Sec <sup>2</sup>	0.115	0.115	0.115	0.115
<b>Torque Constant KT**</b>	<b>Nm/Amp*</b>	<b>0.82</b>	<b>0.59</b>	<b>0.47</b>	<b>0.35</b>
	<b>lb - in/Amp*</b>	<b>7.3</b>	<b>5.2</b>	<b>4.2</b>	<b>3.1</b>
Voltage Constant KV**	Volts Sec Rad <sup>-1*</sup>	0.82	0.59	0.47	0.35
Peak Stall Torque**	Nm	59	59	59	59
	lb - in	520	520	520	520
Current at Peak Torque**	Amps	71	100	125	170
Theoretical Acceleration at Peak Torque	Rad/Sec <sup>2</sup>	4500	4500	4500	4500
<b>Winding</b>					
Armature Resistance Less Brushes**	Ohms*	1.10	0.55	0.35	0.19
Armature Inductance	Millihenrys*	5.0	2.45	1.50	0.90
Mechanical Time Constant**	Milliseconds	22.0	22.0	22.0	22.0
<b>Thermal</b>					
Insulation Class		H	H	H	H
Max. Ambient Temperature	°C	40	40	40	40
Thermal Time Constant	Minutes*	40	40	40	40
<b>Mechanical</b>					
Static Friction Torque	Nm	0.50	0.50	0.50	0.50
	lb - in	4.4	4.4	4.4	4.4
Motor Weight	Kg	23	23	23	23
	lb	51	51	51	51
<b>TACHOMETER</b>					
Voltage Gradient	Volts/1000RPM*	9.5	STANDARD FOR USA ONLY		
	Volts Sec Rad <sup>-1*</sup>		7		
Ripple	Per Cent	1.0	1.0		
	Cycles/Rev	25	25		
Armature Resistance**	Ohms	36	24		
Armature Inductance	Millihenrys*	55	36		
Maximum Current	Amps	0.025	0.035		

\* Tolerance Plus or Minus 10%

\*\* At 25°C

\*\*\* At 40°C Ambient

■ **Motor Performance** data is on the basis of a pure D.C. i.e. unity system form factor supply. Appropriate performance derating is necessary when using a supply with a system form factor greater than unity.

■ **Commutation Curves** opposite and peak torque are based on the **peak value** of the current wave form. For a form factor greater than unity the maximum torque permitted will be lower than that detailed on the performance curves. **IMPORTANT** The commutation curves are based on a load inertia equal to the motor inertia. Advice should be taken in the event the load inertia is greater than the motor inertia.

# STALL TORQUE 8.0Nm / 70lb-in

## Performance Curves

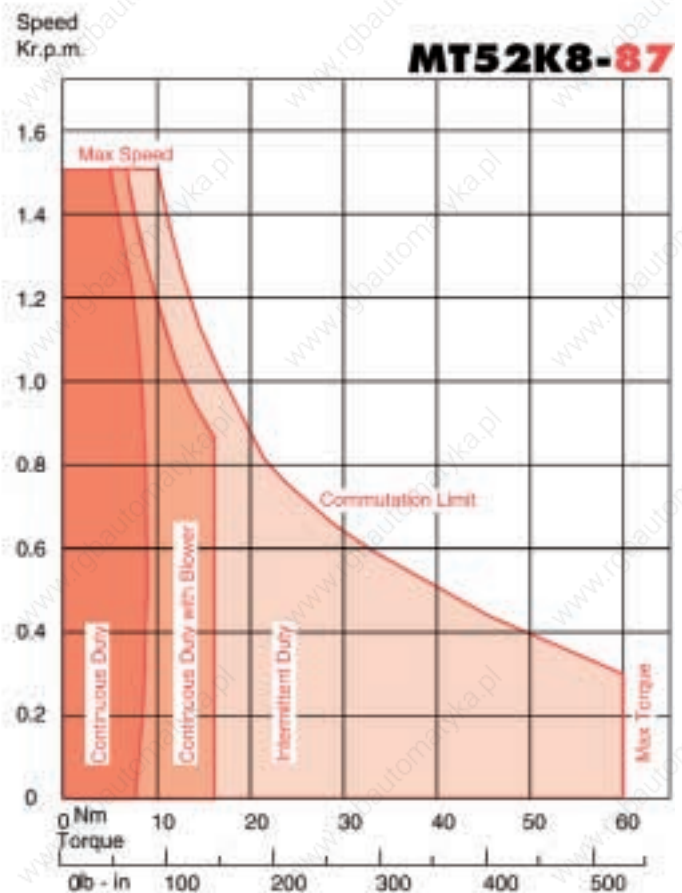
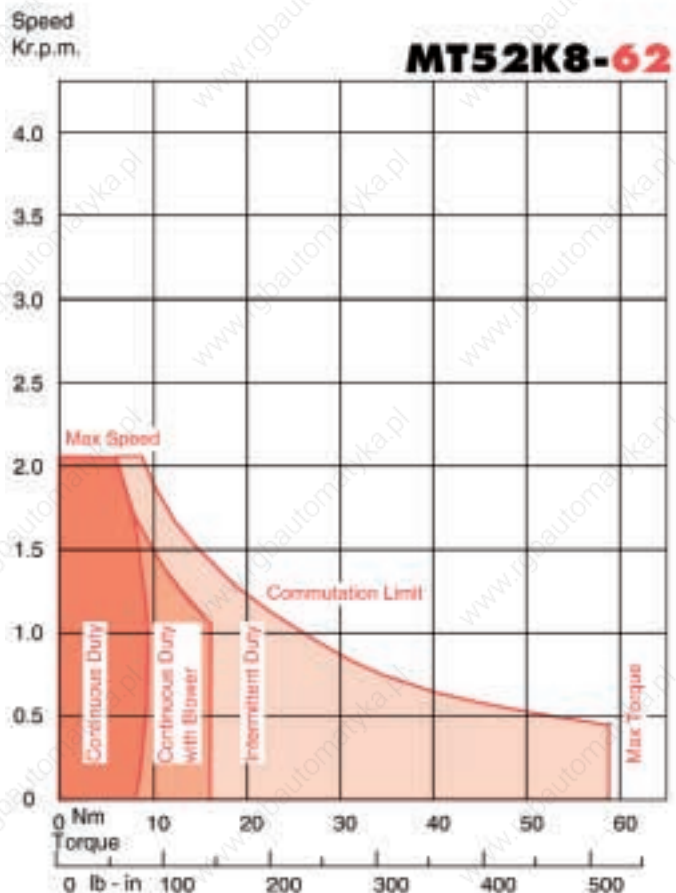
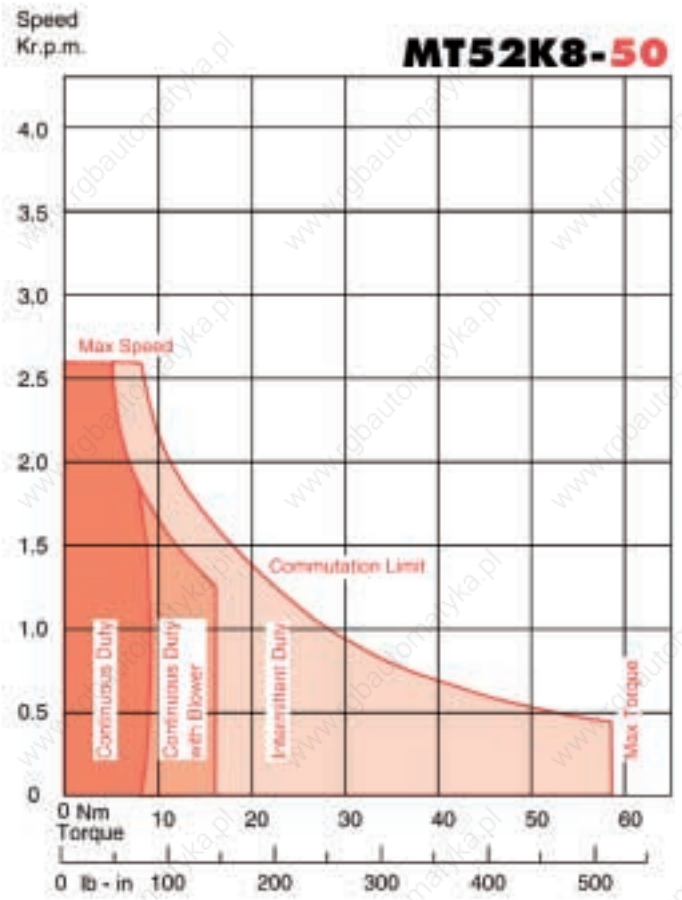
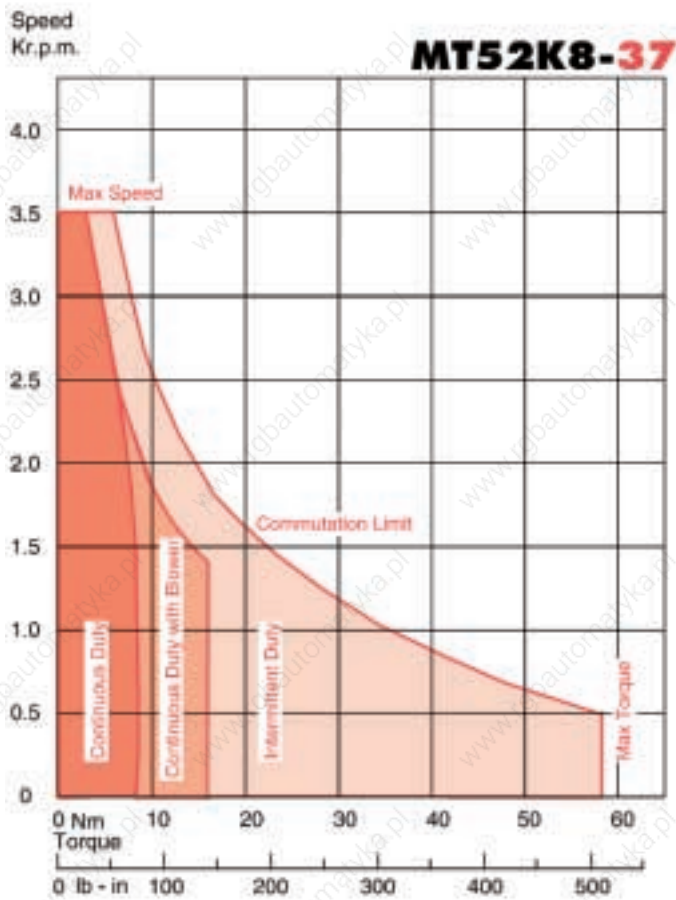

# MT52V8 D.C. Servomotors

## Technical Data

Parameter	Unit	MT52V8-87	MT52V8-69	MT52V8-50	MT52V8-37
<b>GENERAL</b>					
Voltage Gradient No Load	Volts/1000RPM*	87	69	50	37
Max. Terminal Voltage	Volts	130	130	130	130
Max. Speed	RPM	1500	1900	2600	3500
<b>Continuous Stall Torque TENV***</b>	<b>Nm</b>	<b>15.0</b>	<b>15.0</b>	<b>15.0</b>	<b>15.0</b>
	<b>lb - in</b>	<b>130</b>	<b>130</b>	<b>130</b>	<b>130</b>
Continuous Stall Torque Blower Cooled***	Nm	30.0	30.0	30.0	30.0
	lb - in	265	265	265	265
<b>Continuous Stall Current TENV***</b>	<b>Amps</b>	<b>18.3</b>	<b>23.8</b>	<b>33.3</b>	<b>44.0</b>
Armature Polar Moment of Inertia	Kgm <sup>2</sup>	0.026	0.026	0.026	0.026
	lb - in Sec <sup>2</sup>	0.230	0.230	0.230	0.230
<b>Torque Constant KT**</b>	<b>Nm/Amp*</b>	<b>0.82</b>	<b>0.65</b>	<b>0.47</b>	<b>0.34</b>
	<b>lb - in/Amp*</b>	<b>7.2</b>	<b>5.8</b>	<b>4.1</b>	<b>3.0</b>
Voltage Constant KV**	Volts Sec Rad <sup>-1*</sup>	0.82	0.63	0.45	0.34
Peak Stall Torque**	Nm	110	110	110	110
	lb - in	970	970	970	970
Current at Peak Torque**	Amps	140	180	250	330
Theoretical Acceleration at Peak Torque	Rad/Sec <sup>2</sup>	4200	4200	4200	4200
<b>Winding</b>					
Armature Resistance Less Brushes**	Ohms*	0.41	0.25	0.13	0.07
Armature Inductance	Millihenrys*	2.0	1.3	0.7	0.4
Mechanical Time Constant**	Milliseconds	18.0	18.0	18.0	18.0
<b>Thermal</b>					
Insulation Class		H	H	H	H
Max. Ambient Temperature	°C	40	40	40	40
Thermal Time Constant**	Minutes*	60	60	60	60
<b>Mechanical</b>					
Static Friction Torque	Nm	0.60	0.60	0.60	0.60
	lb - in	5.3	5.3	5.3	5.3
Motor Weight	Kg	31	31	31	31
	lb	68	68	68	68
<b>TACHOMETER</b>					
Voltage Gradient	Volts/1000RPM*	9.5		7	
	Volts Sec Rad <sup>-1*</sup>	0.090		0.067	
Ripple	Per Cent	1.0		1.0	
	Cycles/Rev	25		25	
Armature Resistance**	Ohms	36		24	
Armature Inductance	Millihenrys*	55		36	
Maximum Current	Amps	0.025		0.035	

\* Tolerance Plus or Minus 10%

\*\* At 25°C

\*\*\* At 40°C Ambient

■ **Motor Performance** data is on the basis of a pure D.C. i.e. unity system form factor supply. Appropriate performance derating is necessary when using a supply with a system form factor greater than unity.

■ **Commutation Curves** opposite and peak torque are based on the **peak value** of the current wave form. For a form factor greater than unity the maximum torque permitted will be lower than that detailed on the performance curves. **IMPORTANT** The commutation curves are based on a load inertia equal to the motor inertia. Advice should be taken in the event the load inertia is greater than the motor inertia.

# STALL TORQUE 15.0Nm / 130lb-in

## Performance Curves

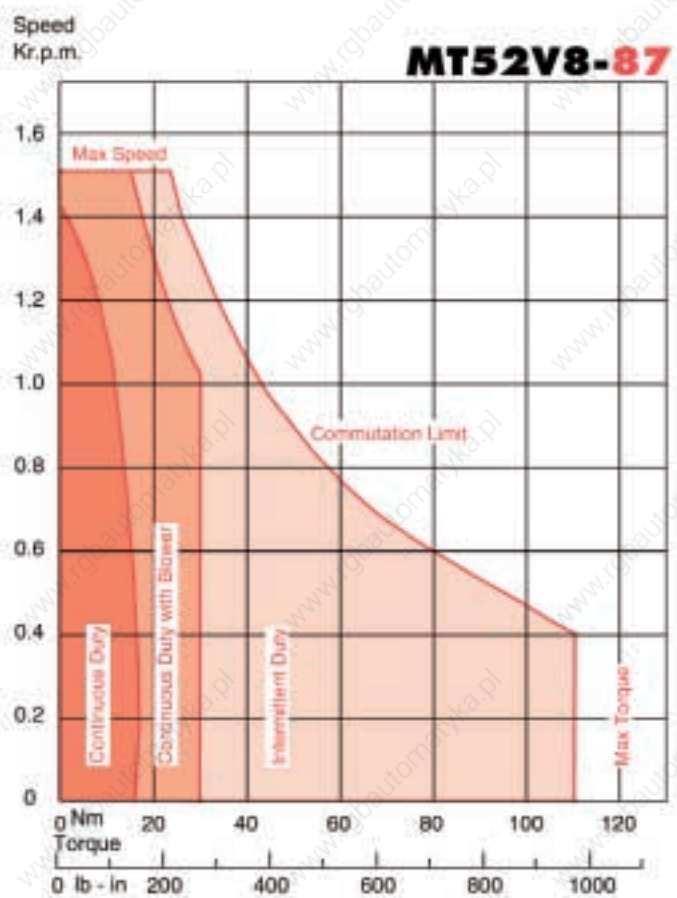
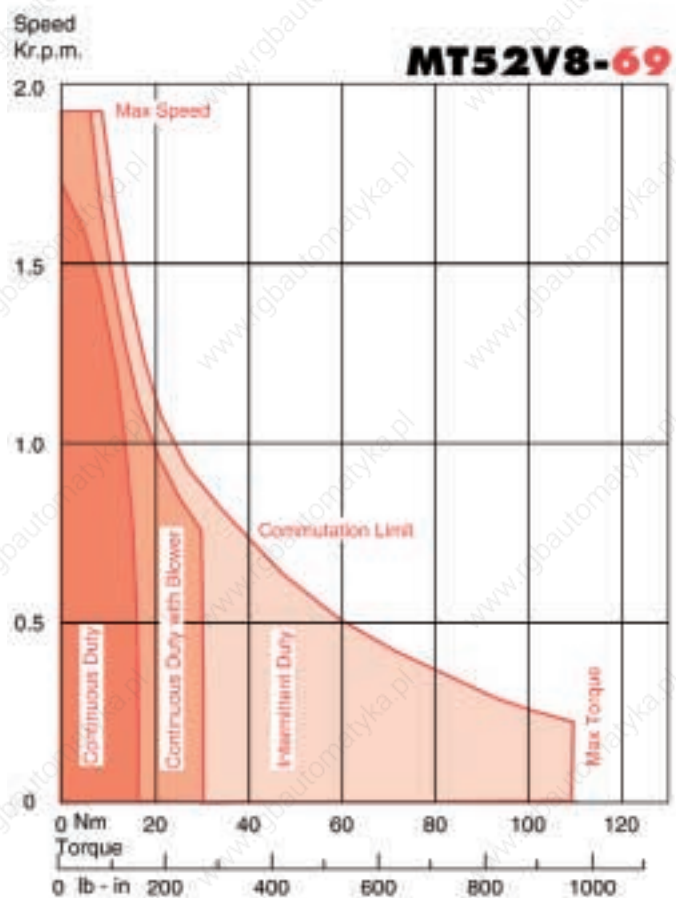
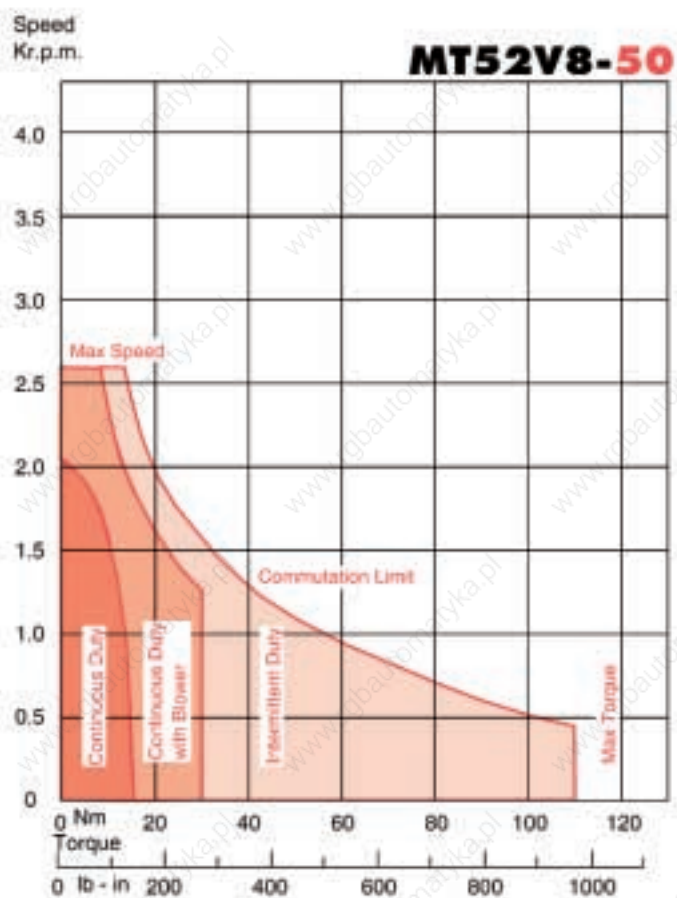
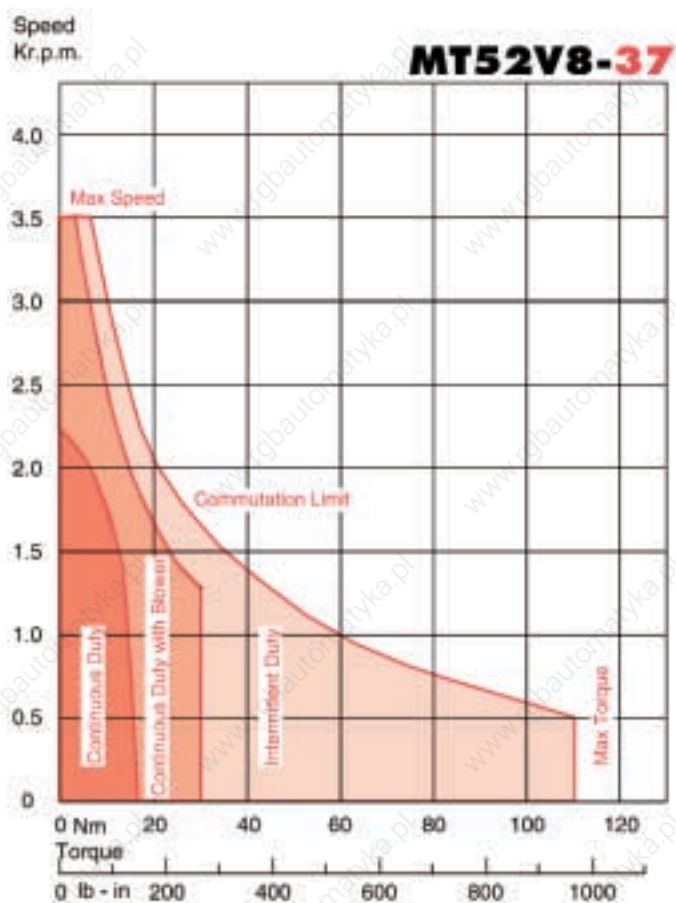

# MT52ZF8 D.C. Servomotors

## Technical Data

Parameter	Unit	MT52ZF8-86	MT52ZF8-67	MT52ZF8-48	MT52ZF8-38
<b>GENERAL</b>					
Voltage Gradient No Load	Volts/1000RPM*	86	67	48	38
Max. Terminal Voltage	Volts	130	130	130	130
Max. Speed	RPM	1500	2000	2700	3500
<b>Continuous Stall Torque TENV***</b>	<b>Nm</b>	<b>22.0</b>	<b>22.0</b>	<b>18.0</b>	<b>16.0</b>
	<b>lb - in</b>	<b>190</b>	<b>190</b>	<b>160</b>	<b>140</b>
Continuous Stall Torque Blower Cooled***	Nm	45.0	45.0	35.0	30.0
	lb - in	400	400	310	265
<b>Continuous Stall Current TENV***</b>	<b>Amps</b>	<b>26.0</b>	<b>34.0</b>	<b>39.0</b>	<b>43.0</b>
Armature Polar Moment of Inertia	Kgm <sup>2</sup>	0.034	0.034	0.034	0.034
	lb - in Sec <sup>2</sup>	0.300	0.300	0.300	0.300
<b>Torque Constant KT**</b>	<b>Nm/Amp*</b>	<b>0.81</b>	<b>0.65</b>	<b>0.46</b>	<b>0.37</b>
	<b>lb - in/Amp*</b>	<b>7.2</b>	<b>5.7</b>	<b>4.1</b>	<b>3.3</b>
Voltage Constant KV**	Volts Sec Rad <sup>-1*</sup>	0.84	0.65	0.46	0.37
Peak Stall Torque**	Nm	180	180	180	180
	lb - in	1600	1600	1600	1600
Current at Peak Torque**	Amps	220	285	400	500
Theoretical Acceleration at Peak Torque	Rad/Sec <sup>2</sup>	5300	5300	5300	5300
<b>Winding</b>					
Armature Resistance Less Brushes**	Ohms*	0.216	0.136	0.060	0.043
Armature Inductance	Millihenrys*	1.0	0.6	0.3	0.2
Mechanical Time Constant**	Milliseconds	11.0	11.0	11.0	11.0
<b>Thermal</b>					
Insulation Class		H	H	H	H
Max. Ambient Temperature	°C	40	40	40	40
Thermal Time Constant**	Minutes*	75	75	75	75
<b>Mechanical</b>					
Static Friction Torque	Nm	0.70	0.70	0.70	0.70
	lb - in	6.2	6.2	6.2	6.2
Motor Weight	Kg	39	39	39	39
	lb	86	86	86	86
<b>TACHOMETER</b>					
Voltage Gradient	Volts/1000RPM*	9.5		7	
	Volts Sec Rad <sup>-1*</sup>	0.090		0.067	
Ripple	Per Cent	1.0		1.0	
	Cycles/Rev	25		25	
Armature Resistance**	Ohms	36		24	
Armature Inductance	Millihenrys*	55		36	
Maximum Current	Amps	0.025		0.035	

\* Tolerance Plus or Minus 10%

\*\* At 25°C

\*\*\* At 40°C Ambient

■ **Motor Performance** data is on the basis of a pure D.C. i.e. unity system form factor supply. Appropriate performance derating is necessary when using a supply with a system form factor greater than unity.

■ **Commutation Curves** opposite and peak torque are based on the **peak value** of the current wave form. For a form factor greater than unity the maximum torque permitted will be lower than that detailed on the performance curves. **IMPORTANT** The commutation curves are based on a load inertia equal to the motor inertia. Advice should be taken in the event the load inertia is greater than the motor inertia.

# STALL TORQUE 16 - 22Nm / 140 - 190lb-in

## Performance Curves

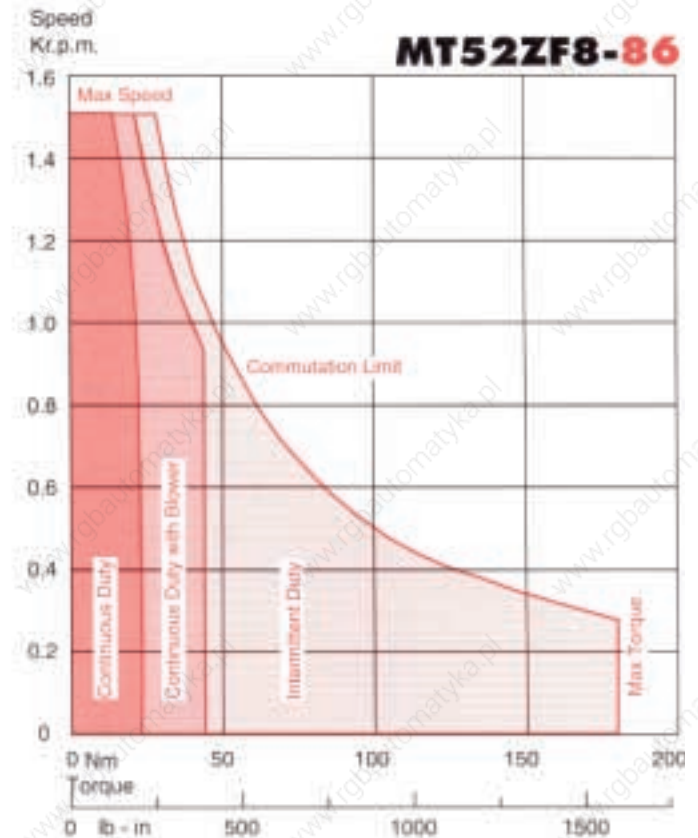
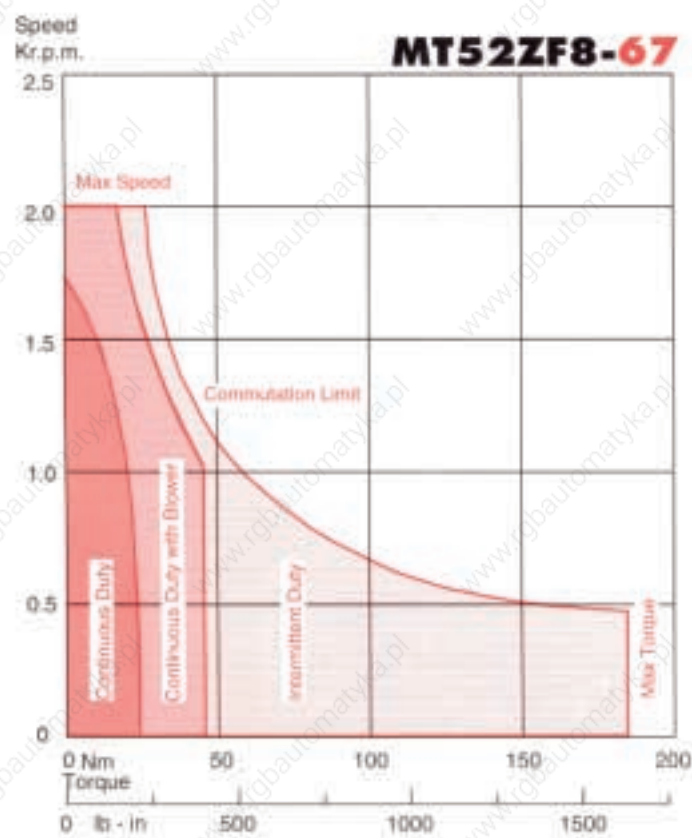
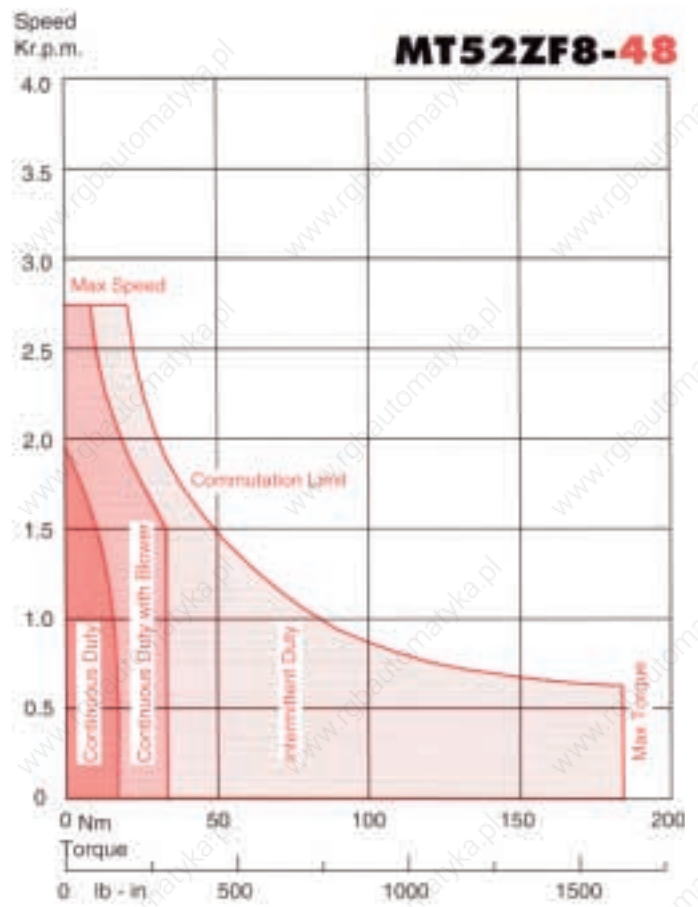
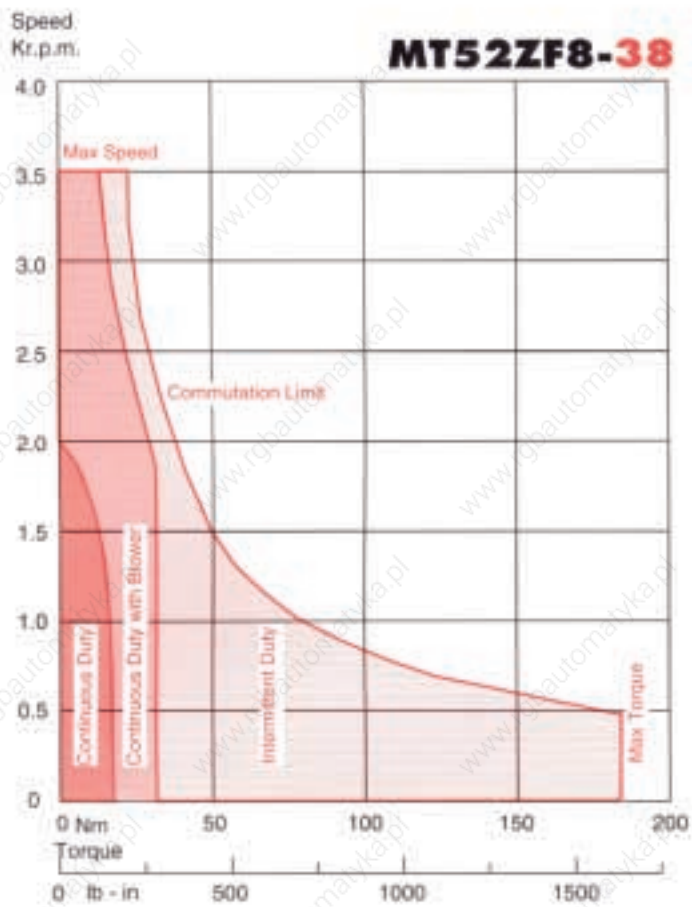

# MT52ZR8 D.C. Servomotors

## Technical Data

Parameter	Unit	MT52ZR8-92	MT52ZR8-66	MT52ZR8-53	MT52ZR8-39
<b>GENERAL</b>					
Voltage Gradient No Load	Volts/1000RPM*	92	66	53	39
Max. Terminal Voltage	Volts	130	130	130	130
Max. Speed	RPM	1400	2000	2500	3300
<b>Continuous Stall Torque TENV***</b>	<b>Nm</b>	<b>30.0</b>	<b>24.0</b>	<b>21.0</b>	<b>16.0</b>
	<b>lb - in</b>	<b>260</b>	<b>210</b>	<b>190</b>	<b>140</b>
Continuous Stall Torque Blower Cooled***	Nm	55.0	45.0	40.0	30.0
	lb - in	490	400	350	270
<b>Continuous Stall Current TENV***</b>	<b>Amps</b>	<b>36.0</b>	<b>40.0</b>	<b>42.0</b>	<b>43.0</b>
Armature Polar Moment of Inertia	Kgm <sup>2</sup>	0.043	0.043	0.043	0.043
	lb - in Sec <sup>2</sup>	0.380	0.380	0.380	0.380
<b>Torque Constant KT**</b>	<b>Nm/Amp*</b>	<b>0.85</b>	<b>0.61</b>	<b>0.5</b>	<b>0.37</b>
	<b>lb - in/Amp*</b>	<b>7.5</b>	<b>5.4</b>	<b>4.4</b>	<b>3.3</b>
Voltage Constant KV**	Volts Sec Rad <sup>-1*</sup>	0.85	0.61	0.5	0.37
Peak Stall Torque**	Nm	240	240	240	240
	lb - in	2100	2100	2100	2100
Current at Peak Torque**	Amps	285	400	500	650
Theoretical Acceleration at Peak Torque	Rad/Sec <sup>2</sup>	5600	5600	5600	5600
<b>Winding</b>					
Armature Resistance Less Brushes**	Ohms*	0.170	0.084	0.054	0.029
Armature Inductance	Millihenrys*	0.78	0.40	0.25	0.14
Mechanical Time Constant**	Milliseconds	10.0	10.0	10.0	10.0
<b>Thermal</b>					
Insulation Class		H	H	H	H
Max. Ambient Temperature	°C	40	40	40	40
Thermal Time Constant	Minutes*	90	90	90	90
<b>Mechanical</b>					
Static Friction Torque	Nm	0.70	0.70	0.70	0.70
	lb - in	6.2	6.2	6.2	6.2
Motor Weight	Kg	48	48	48	48
	lb	106	106	106	106
<b>TACHOMETER</b>					
Voltage Gradient	Volts/1000RPM*	9.5		7	
	Volts Sec Rad <sup>-1*</sup>	0.090		0.067	
Ripple	Per Cent	1.0		1.0	
	Cycles/Rev	25		25	
Armature Resistance**	Ohms	36		24	
Armature Inductance	Millihenrys*	55		36	
Maximum Current	Amps	0.025		0.035	

\* Tolerance Plus or Minus 10%

\*\* At 25°C

\*\*\* At 40°C Ambient

■ **Motor Performance** data is on the basis of a pure D.C. i.e. unity system form factor supply. Appropriate performance derating is necessary when using a supply with a system form factor greater than unity.

■ **Commutation Curves** opposite and peak torque are based on the **peak value** of the current wave form. For a form factor greater than unity the maximum torque permitted will be lower than that detailed on the performance curves. **IMPORTANT** The commutation curves are based on a load inertia equal to the motor inertia. Advice should be taken in the event the load inertia is greater than the motor inertia.

# STALL TORQUE 16 - 30Nm / 140 - 260lb-in

## Performance Curves

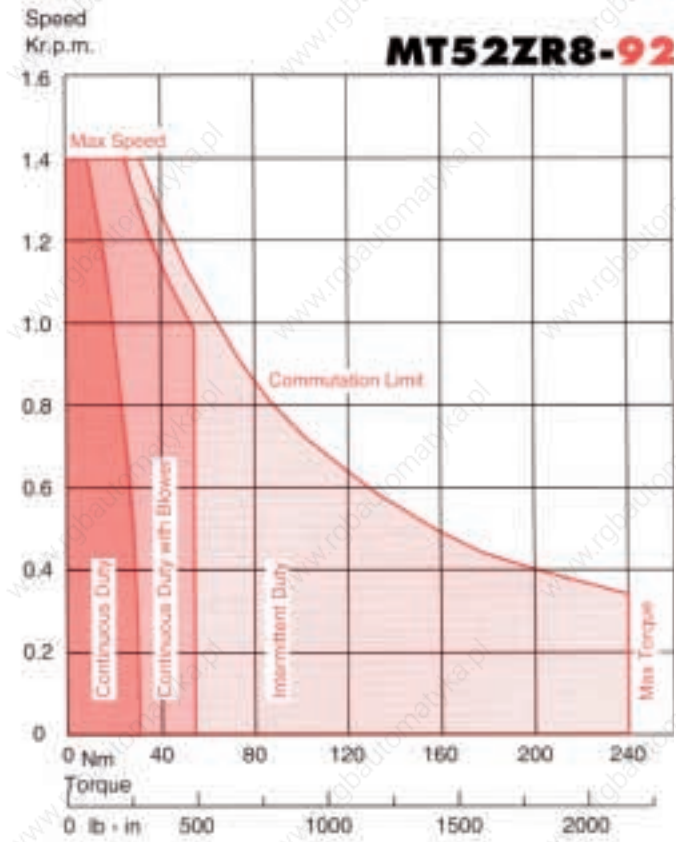
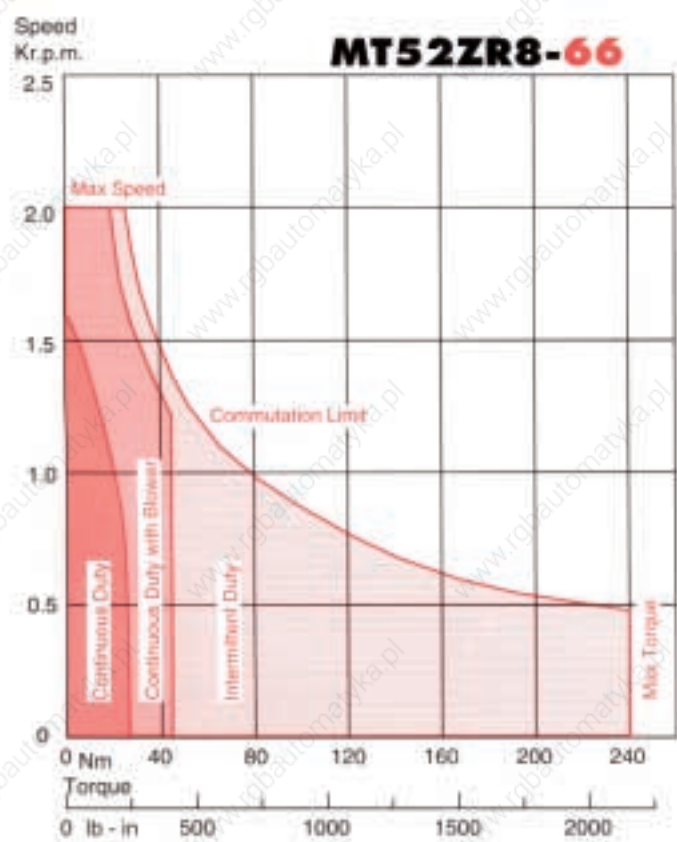
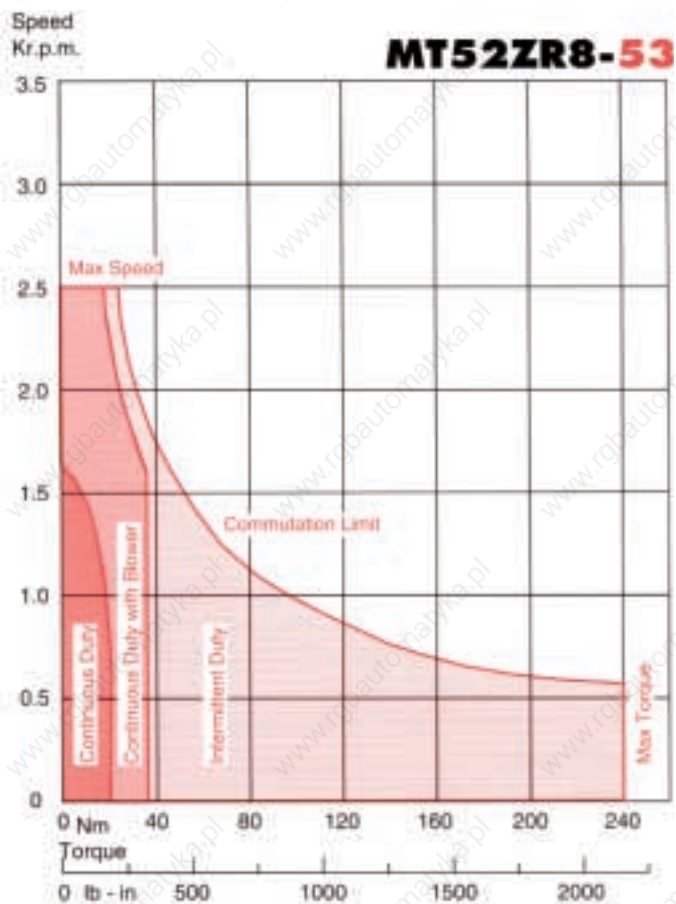
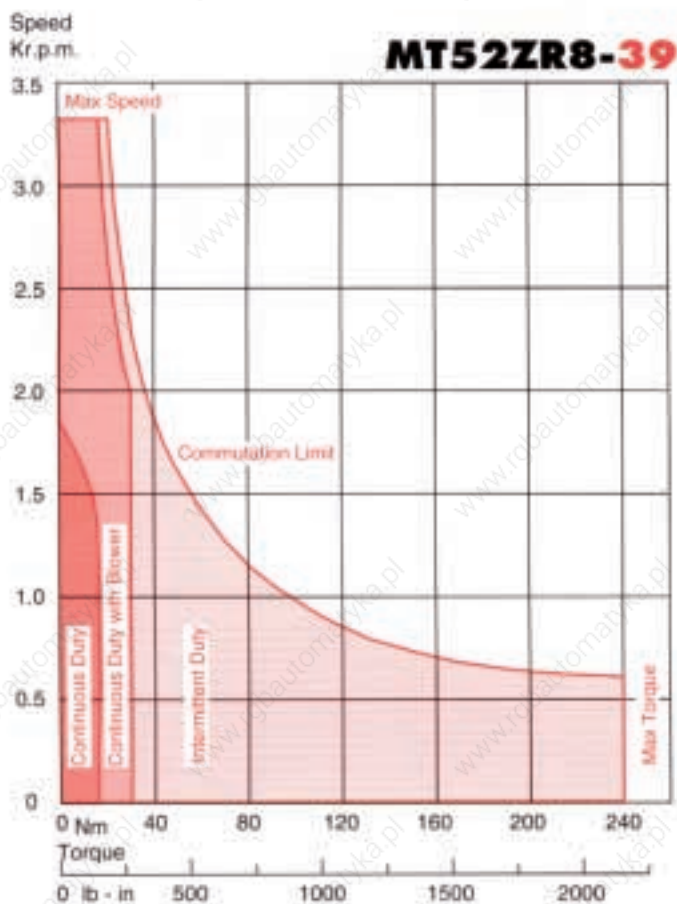

# DBMT52ZF8 D.C. Servomotors

## Technical Data

Parameter	Unit	DBMT52ZF8-86	DBMT52ZF8-67	DBMT52ZF8-48	DBMT52ZF8-38
<b>GENERAL</b>					
Voltage Gradient No Load	Volts/1000RPM*	86	67	48	38
Max. Terminal Voltage	Volts	130	130	130	130
Max. Speed	RPM	1500	2000	2700	3500
<b>Continuous Stall Torque TENV***</b>	<b>Nm</b>	<b>27.5</b>	<b>27.5</b>	<b>27.5</b>	<b>27.5</b>
	<b>lb - in</b>	<b>240</b>	<b>240</b>	<b>240</b>	<b>240</b>
Continuous Stall Torque Blower Cooled***	Nm	45	45	45	45
	lb - in	400	400	400	400
<b>Continuous Stall Current TENV***</b>	<b>Amps</b>	<b>34.0</b>	<b>43.0</b>	<b>60.0</b>	<b>74.0</b>
Armature Polar Moment of Inertia	Kgm <sup>2</sup>	0.038	0.038	0.038	0.038
	lb - in Sec <sup>2</sup>	0.34	0.34	0.34	0.34
<b>Torque Constant KT**</b>	<b>Nm/Amp*</b>	<b>0.81</b>	<b>0.65</b>	<b>0.46</b>	<b>0.37</b>
	<b>lb - in/Amp*</b>	<b>7.2</b>	<b>5.7</b>	<b>4.1</b>	<b>3.3</b>
Voltage Constant KV**	Volts Sec Rad <sup>-1*</sup>	0.81	0.65	0.46	0.37
Peak Stall Torque**	Nm	180	180	180	180
	lb - in	1600	1600	1600	1600
Current at Peak Torque**	Amps	220	285	400	500
Theoretical Acceleration at Peak Torque	Rad/Sec <sup>2</sup>	4700	4700	4700	4700
<b>Winding</b>					
Armature Resistance Less Brushes**	Ohms*	0.216	0.136	0.060	0.043
Armature Inductance	Millihenrys*	1.0	0.6	0.3	0.2
Mechanical Time Constant**	Milliseconds	12.5	12.5	12.5	12.5
<b>Thermal</b>					
Insulation Class		H	H	H	H
Max. Ambient Temperature	°C	40	40	40	40
Thermal Time Constant	Minutes*	75	75	75	75
<b>Mechanical</b>					
Static Friction Torque	Nm	1.0	1.0	1.0	1.0
	lb - in	9.0	9.0	9.0	9.0
Motor Weight	Kg	41	41	41	41
	lb	90	90	90	90
<b>TACHOMETER</b>					
Voltage Gradient	Volts/1000RPM*	9.5	STANDARD FOR USA ONLY		
	Volts Sec Rad <sup>-1*</sup>		7		
Ripple	Per Cent	1.0	0.067		
	Cycles/Rev		1.0		
Armature Resistance**	Ohms	36	24		
Armature Inductance	Millihenrys*	55	36		
Maximum Current	Amps	0.025	0.035		

\* Tolerance Plus or Minus 10%

\*\* At 25°C

\*\*\* At 40°C Ambient

■ **Motor Performance** data is on the basis of a pure D.C. i.e. unity system form factor supply. Appropriate performance derating is necessary when using a supply with a system form factor greater than unity.

■ **Commutation Curves** opposite and peak torque are based on the **peak value** of the current wave form. For a form factor greater than unity the maximum torque permitted will be lower than that detailed on the performance curves. **IMPORTANT** The commutation curves are based on a load inertia equal to the motor inertia. Advice should be taken in the event the load inertia is greater than the motor inertia.

# STALL TORQUE **27.5Nm / 240lb-in**

## Performance Curves

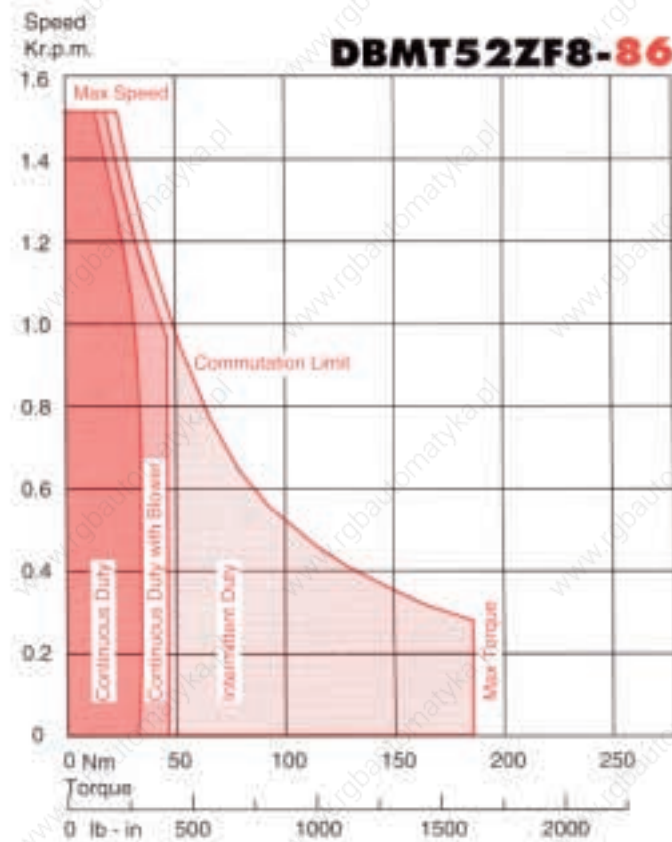
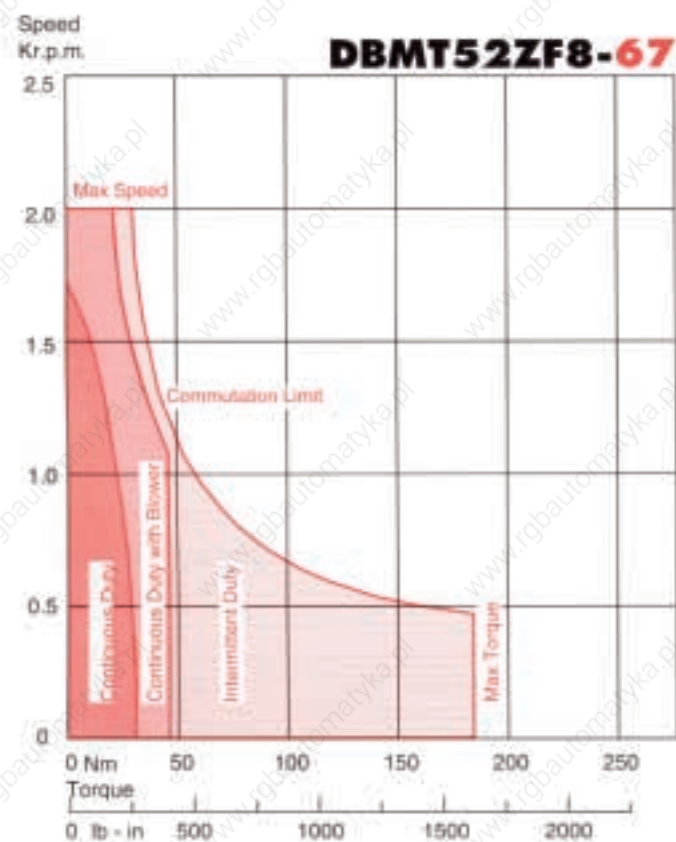
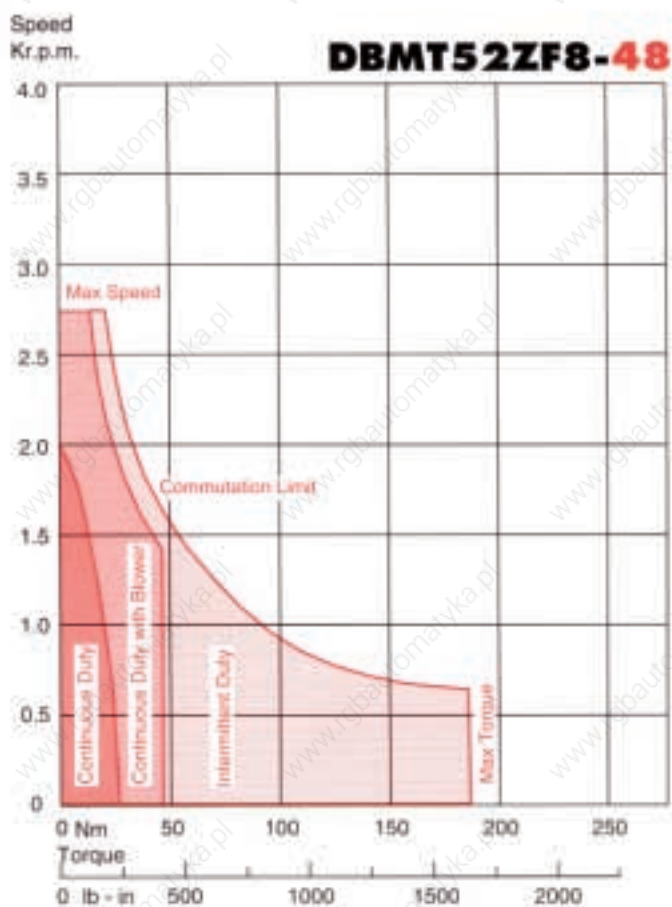
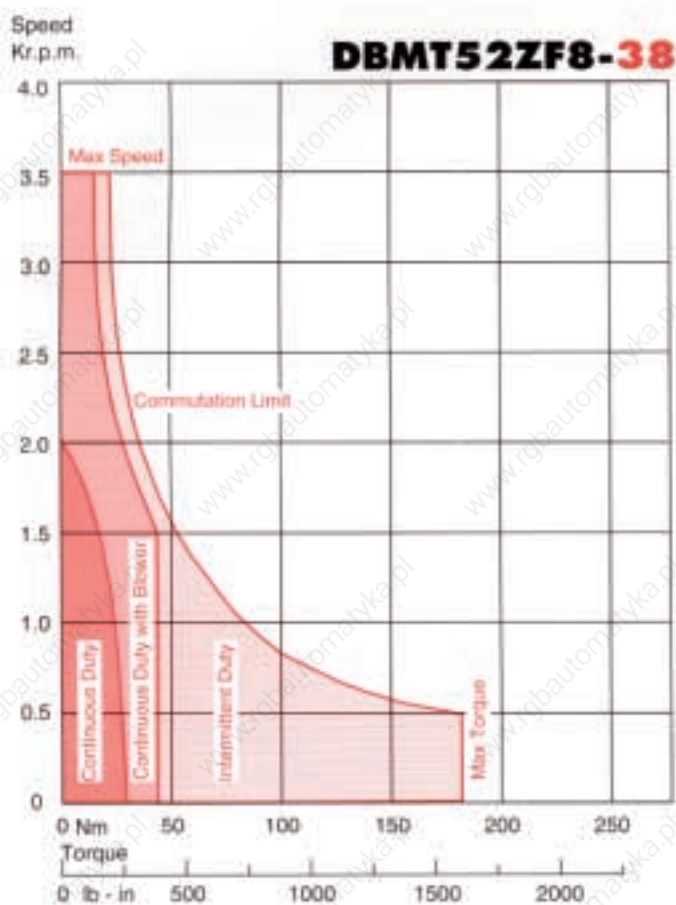

# DBMT52ZR8 D.C. Servomotors

## Technical Data

Parameter	Unit	DBMT52ZR8-92	DBMT52ZR8-66	DBMT52ZR8-53	DBMT52ZR8-39
<b>GENERAL</b>					
Voltage Gradient No Load	Volts/1000RPM*	92	66	53	39
Max. Terminal Voltage	Volts	130	130	130	130
Max. Speed	RPM	1400	2000	2500	3300
<b>Continuous Stall Torque TENV***</b>	<b>Nm</b>	<b>37.0</b>	<b>37.0</b>	<b>34.0</b>	<b>28.0</b>
	<b>lb - in</b>	<b>330</b>	<b>330</b>	<b>300</b>	<b>250</b>
Continuous Stall Torque Blower Cooled***	Nm	55.0	55.0	55.0	55.0
	lb - in	490	490	490	490
<b>Continuous Stall Current TENV***</b>	<b>Amps</b>	<b>44.0</b>	<b>61.0</b>	<b>71.0</b>	<b>76.0</b>
Armature Polar Moment of Inertia	Kgm <sup>2</sup>	0.046	0.046	0.046	0.046
	lb - in Sec <sup>2</sup>	0.410	0.410	0.410	0.410
<b>Torque Constant KT**</b>	<b>Nm/Amp*</b>	<b>0.85</b>	<b>0.61</b>	<b>0.5</b>	<b>0.37</b>
	<b>lb - in/Amp*</b>	<b>7.5</b>	<b>5.4</b>	<b>4.4</b>	<b>3.3</b>
Voltage Constant KV**	Volts Sec Rad <sup>-1*</sup>	0.85	0.61	0.48	0.37
Peak Stall Torque**	Nm	240	240	240	240
	lb - in	2100	2100	2100	2100
Current at Peak Torque**	Amps	285	400	500	650
Theoretical Acceleration at Peak Torque	Rad/Sec <sup>2</sup>	5200	5200	5200	5200
<b>Winding</b>					
Armature Resistance Less Brushes**	Ohms*	0.170	0.084	0.054	0.029
Armature Inductance	Millihenrys*	0.78	0.40	0.25	0.14
Mechanical Time Constant**	Milliseconds	11.0	11.0	11.0	11.0
<b>Thermal</b>					
Insulation Class		H	H	H	H
Max. Ambient Temperature	°C	40	40	40	40
Thermal Time Constant	Minutes*	90	90	90	90
<b>Mechanical</b>					
Static Friction Torque	Nm	1.0	1.0	1.0	1.0
	lb - in	9.0	9.0	9.0	9.0
Motor Weight	Kg	50	50	50	50
	lb	110	110	110	110
<b>TACHOMETER</b>					
Voltage Gradient	Volts/1000RPM*	STANDARD FOR USA ONLY			7
	Volts Sec Rad <sup>-1*</sup>	9.5			0.067
Ripple	Per Cent	1.0			1.0
	Cycles/Rev	25			25
Armature Resistance**	Ohms	36			24
Armature Inductance	Millihenrys*	55			36
Maximum Current	Amps	0.025			0.035

\* Tolerance Plus or Minus 10%

\*\* At 25°C

\*\*\* At 40°C Ambient

■ **Motor Performance** data is on the basis of a pure D.C. i.e. unity system form factor supply. Appropriate performance derating is necessary when using a supply with a system form factor greater than unity.

■ **Commutation Curves** opposite and peak torque are based on the **peak value** of the current wave form. For a form factor greater than unity the maximum torque permitted will be lower than that detailed on the performance curves. **IMPORTANT** The commutation curves are based on a load inertia equal to the motor inertia. Advice should be taken in the event the load inertia is greater than the motor inertia.

# STALL TORQUE 28 - 37Nm / 250 - 330lb-in

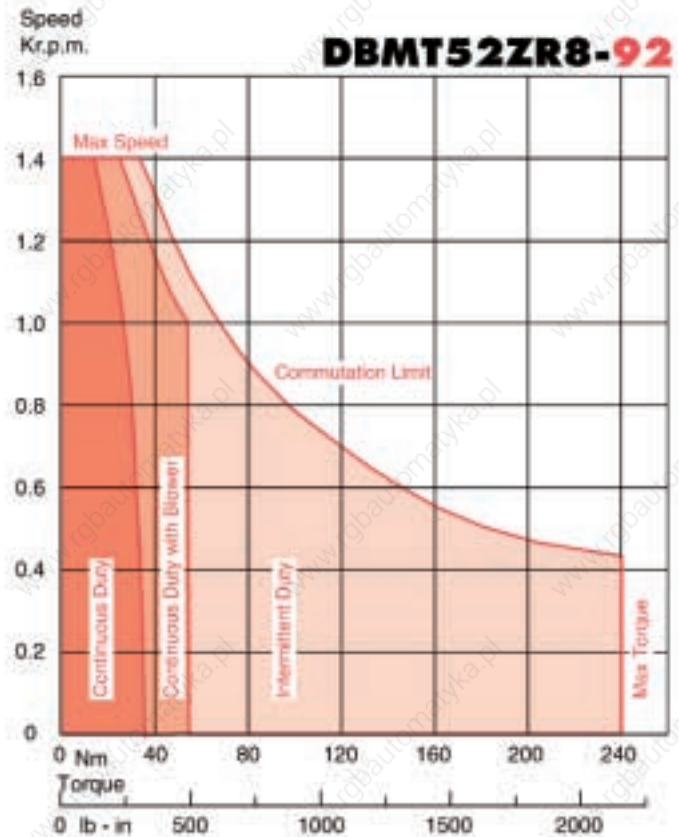
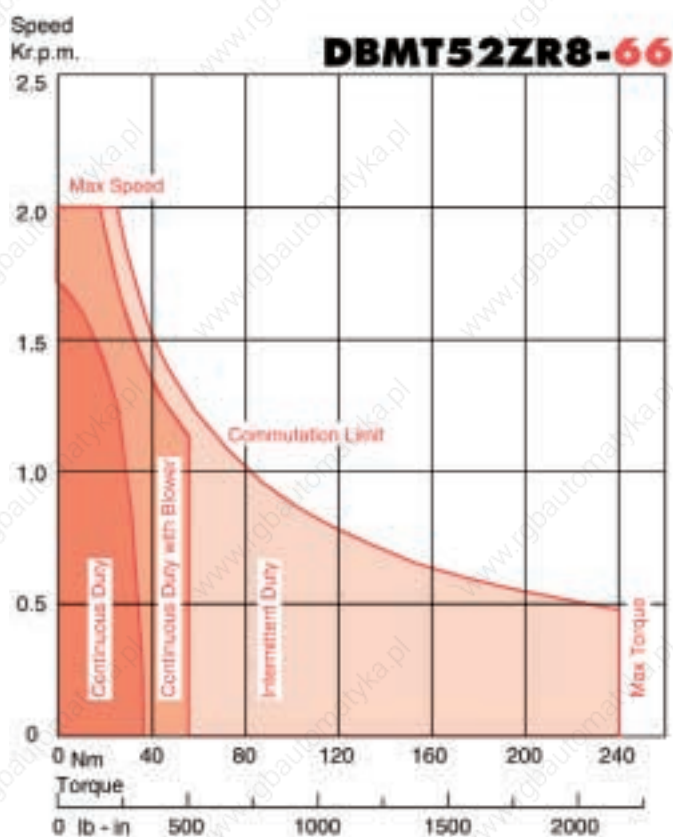
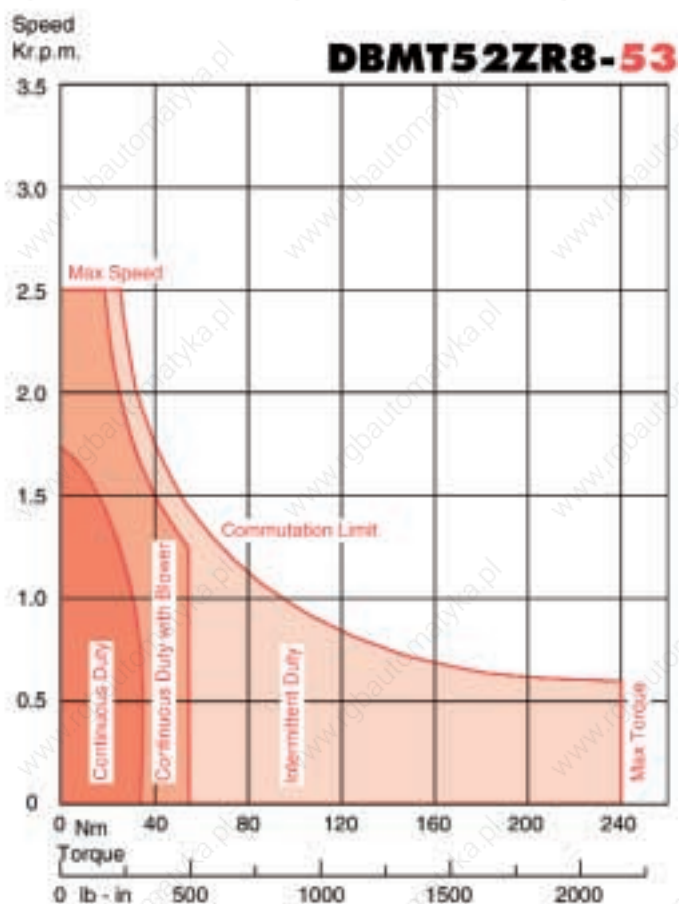
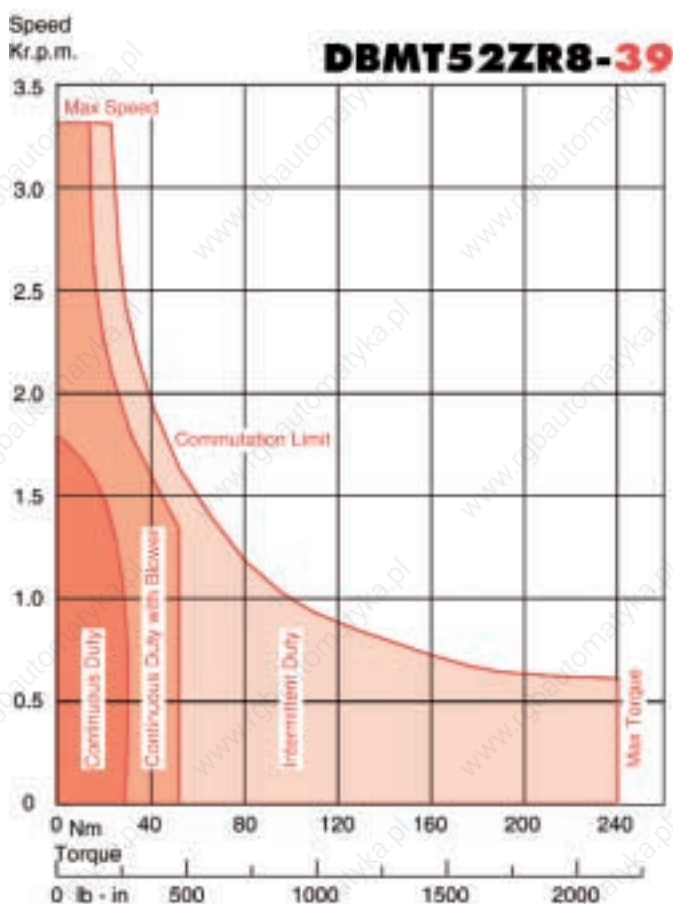

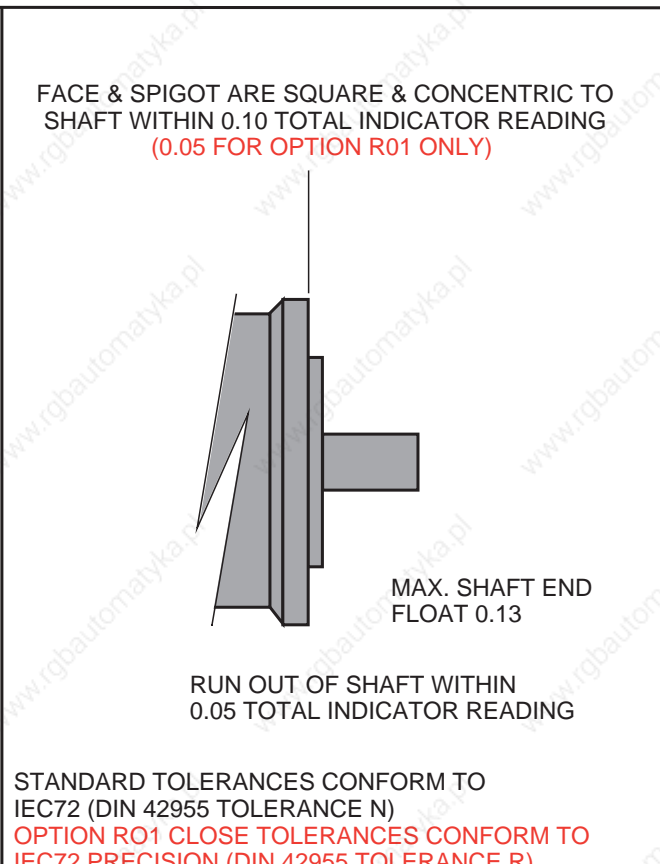
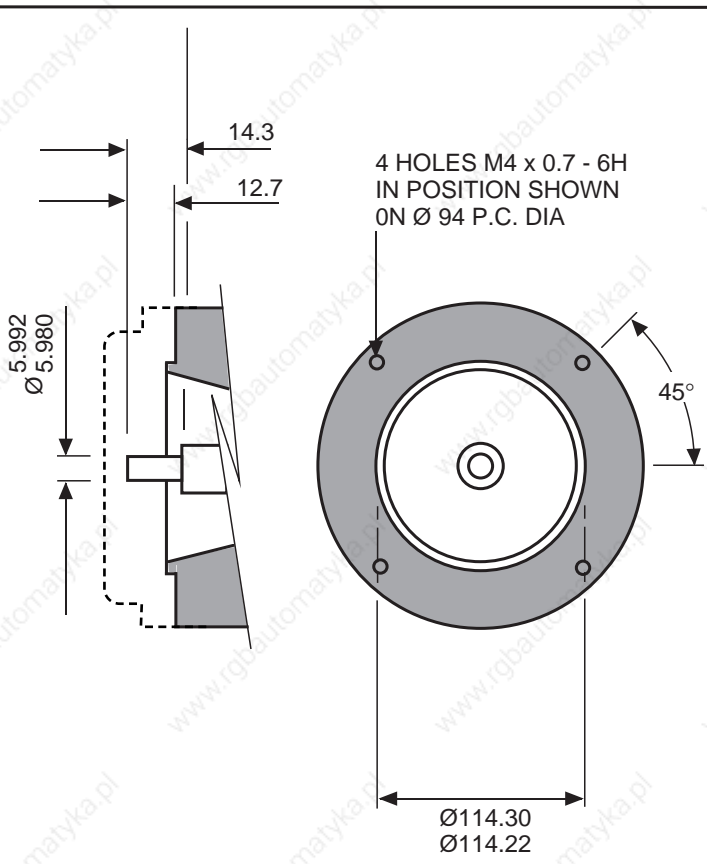

**NON DRIVE END SHAFT ARRANGEMENT**

**DRIVE END INTERFACE TOLERANCES**

DIMENSIONS IN MILLIMETRES FOR INCH SERIES SEE DRAWING C5152/0

**SHAFT LOADING LIMITS**

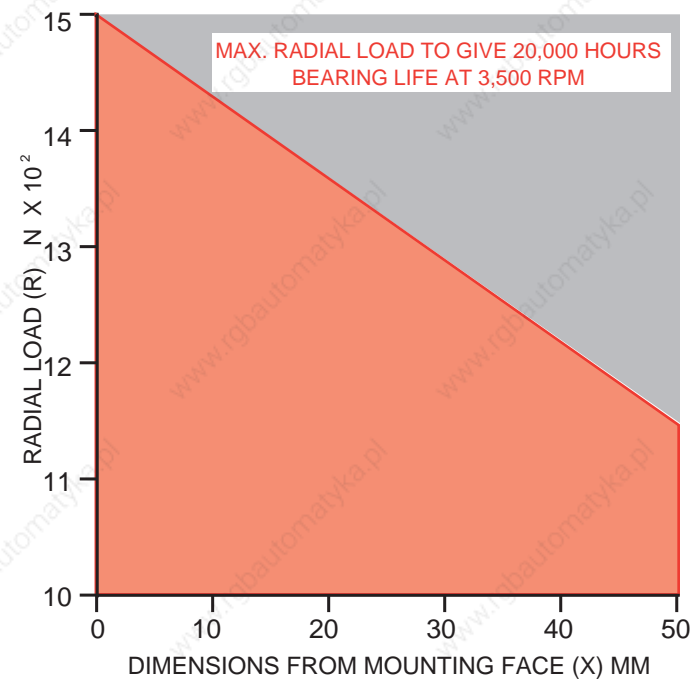
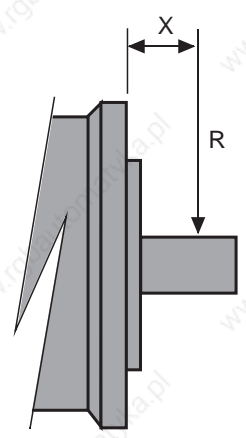

The above graph may be used as a guide for applications and includes an adequate safety factor for normal industrial use. If axial loads are to be applied, SEM should be consulted. Where radial loading in excess of the above maximum is deemed essential, the specific case should be referred to SEM.

METRIC D.C. SERVOMOTORS  
**MT52 SERIES**

**MECHANICAL DETAIL**

**C5152/OM**  
SHEET 1 OF 4 SHEETS

1 HOLE M25 x 1.5 - 7H CONDUIT  
FITTED WITH BUSH

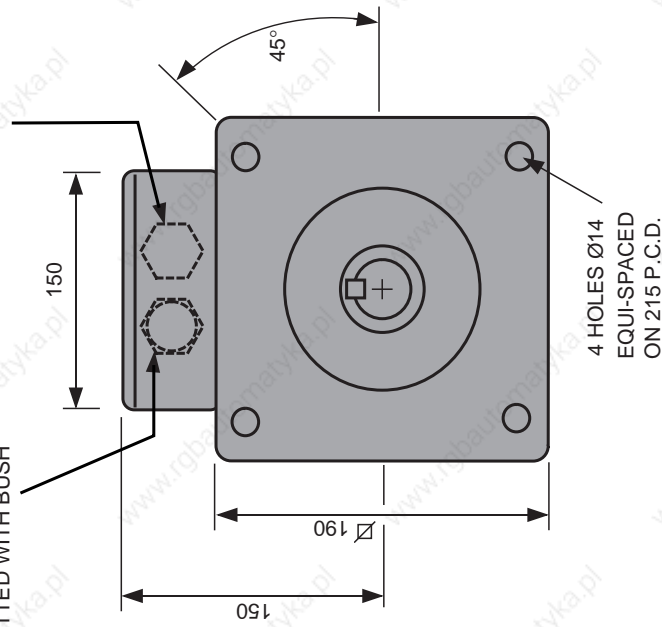

DIMENSIONS IN MILLIMETRES FOR INCH SERIES SEE DRAWING C-5152/0

CD FLANGE OPTION NO. M00

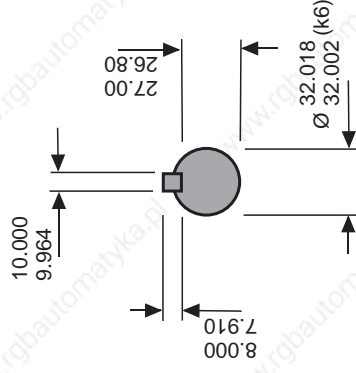
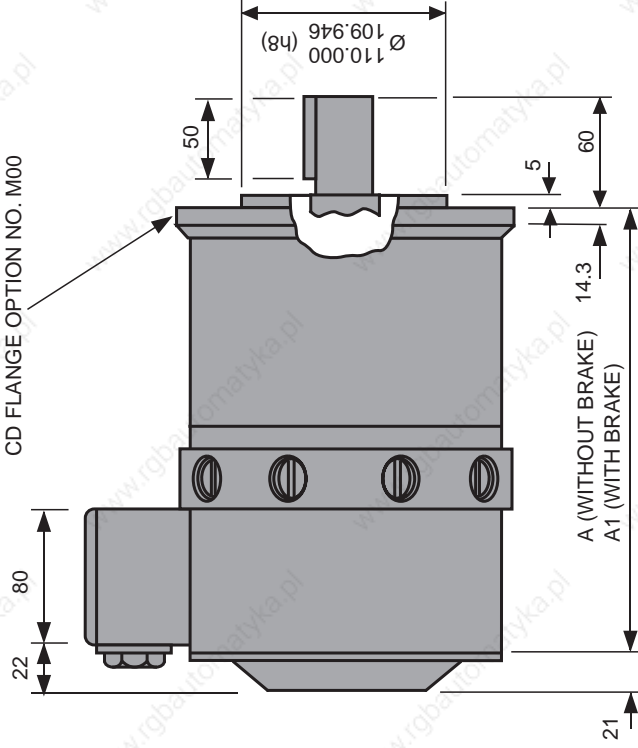

SHAFT END DETAIL

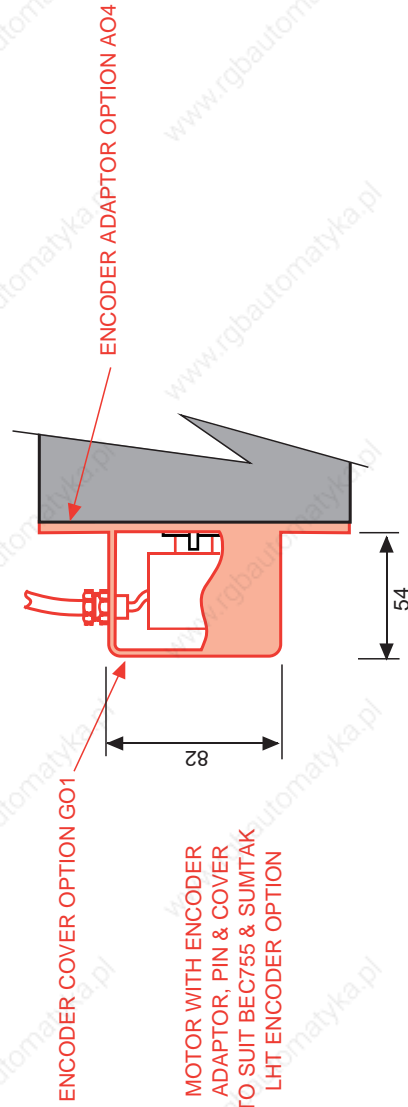

TYPE	A	A1
MT 52 K8	259	331
MT 52 V8	331	403
MT 52 ZF8	403	475
MT 52 ZR8	475	532
DBMT 52 ZF8	430	502
DBMT 52 ZR8	502	559

METRIC D.C. SERVO MOTORS  
**MT52 SERIES**

**STANDARD MT52 SERVO MOTOR**  
WITH ADAPTOR AND COVER FOR BEC755 OR SUMTAK  
ENCODER SHOWN IN RED

**C5152/OM**  
SHEET 2 OF 4 SHEETS

DIMENSIONS IN MILLIMETRES FOR INCH SERIES SEE DRAWING C-5152/0

1 HOLE M20 x 1.5 - 7H CONDUIT  
FITTED WITH PLUG

1 HOLE M25 x 1.5 - 7H CONDUIT  
FITTED WITH BUSH

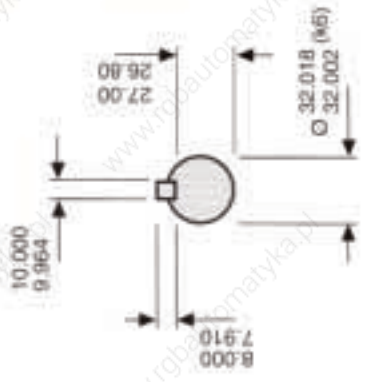
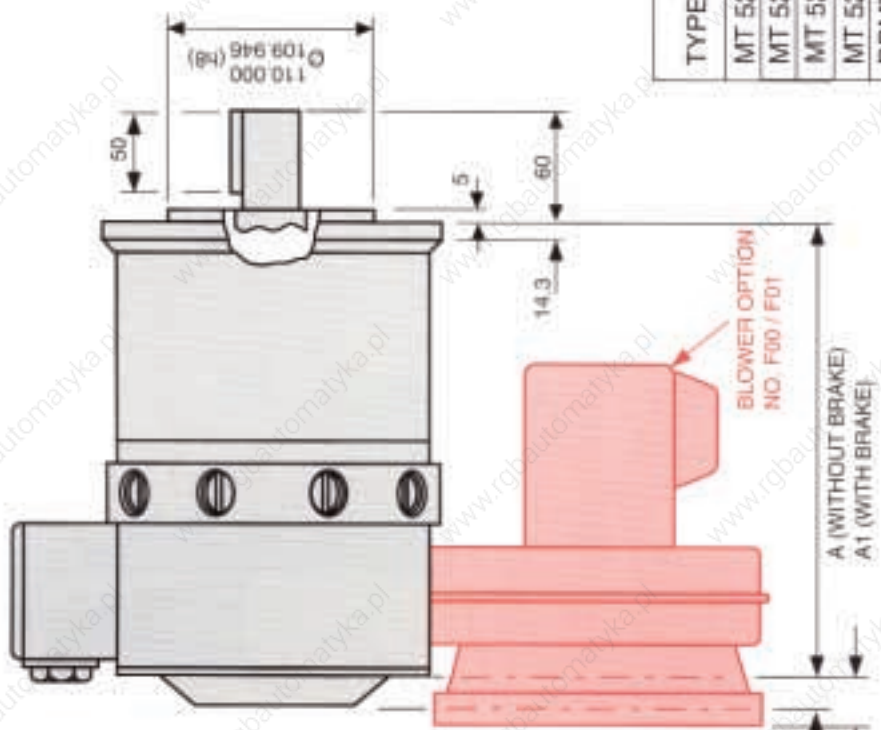
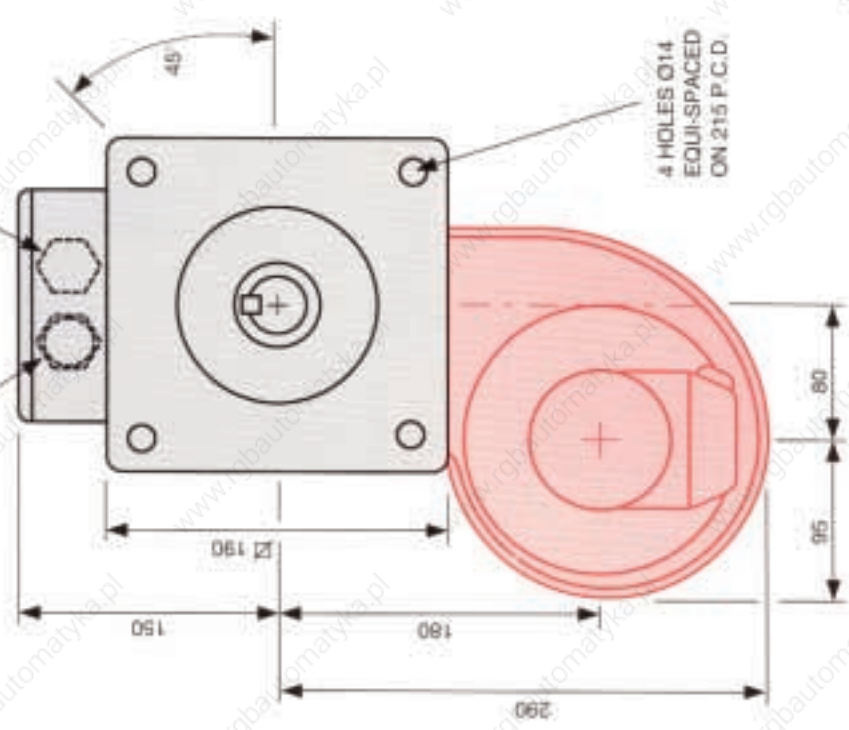

SHAFT END DETAIL

TYPE	A	A1
MT 52 K8	259	331
MT 52 V8	331	403
MT 52 ZF8	403	475
MT 52 ZR8	475	532
DBMT 52 ZF8	430	502
DBMT 52 ZR8	502	559

METRIC D.C. SERVOMOTORS  
**MT52 SERIES**

**MT52 SERVOMOTOR**  
WITH BLOWER OPTION SHOWN IN RED

**C5152/OM**  
SHEET 3 OF 4 SHEETS

DIMENSIONS IN MILLIMETRES FOR INCH SERIES SEE DRAWING C-5152/0

MS CONNECTORS OPTION NO. C02 / C03 (IP44)  
C10 / C11 (IP65)

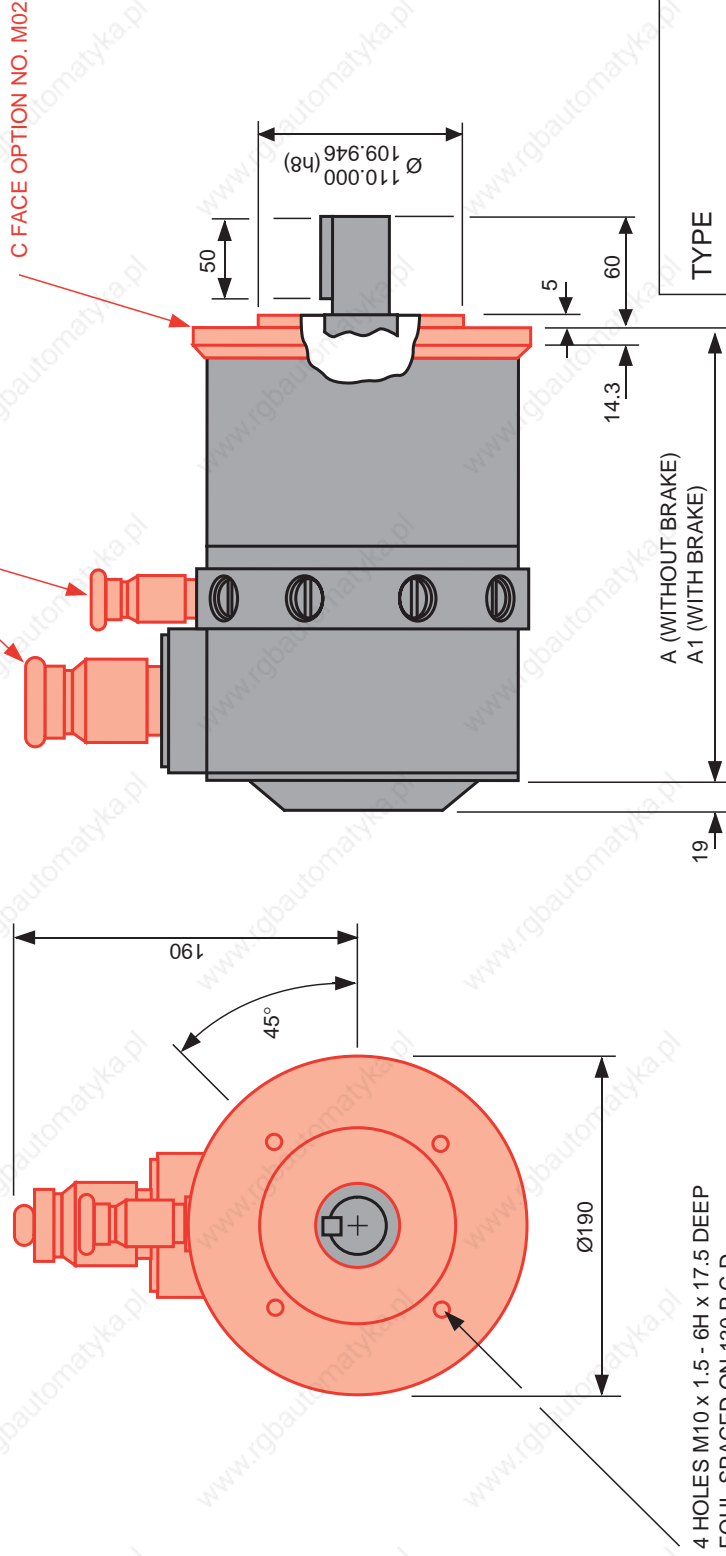

TYPE	A	A1
MT 52 K8	259	331
MT 52 V8	331	403
MT 52 ZF8	403	475
MT 52 ZR8	475	532
DBMT 52 ZF8	430	502
DBMT 52 ZR8	502	559

METRIC D.C. SERVOMOTORS  
**MT52 SERIES**

**MT52 SERVOMOTOR**  
WITH MS CONNECTOR AND 'C' FACE OPTIONS SHOWN IN RED

**C5152/0M**  
SHEET 4 OF 4 SHEETS

Standard features are shown by ● in black.

Available fitted options are shown in red.

Please quote No. and reference of options along with motor type No. when placing an order.

If options or features are required which are not detailed below, they may be possible, so please ask SEM sales.

NO.	REFERENCE	DESCRIPTION
<b>MECHANICAL INTERFACE</b>		
● M00	FLANGE	See page 59
M02	FACE	See page 61
R01	CLOSE TOLERANCE INTERFACE	Interface (face & shaft) to IEC72 PRECISION (DIN 42955 Tolerance R)
● S00	SHAFT	See page 59
● K00	KEYWAY	See page 59
K99	NO KEYWAY	Plain shaft
D01	SHAFT END TAPPED	M12 x 20mm Deep tapped in drive shaft
H01	HAND CRANK	Rear shaft to enable hand rotation of motor
<b>MOTOR PROTECTION</b>		
● P00	IP44/65 PROTECTION	Enclosure protection IP44 at shaft. IP65 for remainder of motor. IP64/65 if shaft seal option W01 is fitted
W01	SHAFT SEAL	Oil seal fitted at drive end/shaft interface
P99	TROPICALISED	Special treatment on internal parts
<b>BRAKES</b>		
B00	24V DC BRAKE	18 Nm torque 24V DC supply
B01	90V DC BRAKE	18 Nm torque 90V DC supply
L01	RECTIFIER	110V AC input 90V DC output for B01 Mounted inside terminal box (supplied loose for external mounting when motor MS Connectors are fitted)
<b>FORCED VENTILATION</b>		
V00	220V BLOWER	220 volt 50HZ single phase input
V01	110V BLOWER	110 volt 50HZ single phase input
V99	PREPARED FOR BLOWER	Motor prepared for blower but no blower fitted (covers are fitted over blower preparation)

NO.	REFERENCE	DESCRIPTION
<b>ELECTRICAL TERMINATIONS</b>		
● C00	TERMINAL BOX	With 1x M20 and 1 x M25 tapped holes
C01	TERMINAL BOX	With 1 x PG16 and 1 x PG21 tapped holes
C02	MS CONNECTORS (IP44)	Motor receptacle MS3102A-32-5P (2 pin) and Feedback receptacle MS3102A-14S-6P (6 pin) fitted to motor
C03	MS PLUGS AND CABLE CLAMPS FOR C02 (IP44)	MS3106A-32-5S and MS3106A-14S-6S straight plugs and cable clamps 97-3057-1020-1 and 97-3057-1007-1
C09	FLYING LEADS OUT	0.5 metre long radial exit (No terminal box)
C10	MS CONNECTORS (IP65)	Motor receptacle MS 3102E-32-5P (2 pin) and feedback receptacle MS 3102E-14S-6P (6 pin) fitted to motor
C11	MS PLUGS FOR C10 (IP65)	MS 3106E-32-5S and MS 3106-14S-6S straight plugs
<b>TACHOGENERATORS</b>		
T07	TACHOGENERATOR	7V/1000 RPM
● T95	TACHOGENERATOR	9.5V/1000 RPM
T19	TACHOGENERATOR	19.5V/1000 RPM
T30	TACHOGENERATOR	30V/1000 RPM
N99	NO TACHOGENERATOR	No velocity feedback
<b>ENCODERS</b>		
E01	ENCODER	HEIDENHAIN ERN1120 Series - 250 PPR
E02	ENCODER	HEIDENHAIN ERN1120 Series - 500 PPR
E03	ENCODER	HEIDENHAIN ERN1120 Series - 1000 PPR
<b>ENCODER FITTINGS</b>		
A01	ENCODER ADAPTOR	for Heidenhain ROD 426, 436, 456, Litton G60 & Leine & Linde type 63
A02	ENCODER ADAPTOR	for Heidenhain ROD 420 & 450
A03	ENCODER ADAPTOR	for Muirhead H25E & Litton G70
A04	ENCODER ADAPTOR	for BEC 755 & SUMTAK model LHT
A05	ENCODER ADAPTOR	for Tamagawa TS5300 series
A06	ADAPTOR	for Size 11 resolver
A10	SYNCHRO CLAMPS	for A01, A03 and A06
G01	ENCODER COVER (IP65)	Cast cover with 1 X M10 tapped hole, and cable gland for A04 only
G02	ENCODER COVER (IP65)	Cast cover with 1 X PG7 tapped hole, and cable gland for A04 only
G03	ENCODER COVER (IP44)	Cast cover with MS receptacle MS3102A-18-1P, for A04 only (IP44)
G07	ENCODER COVER (IP65)	Cast cover with 2 x axial exit cable glands for A05 & A06 only
G15	ENCODER COVER (IP65)	Cast cover with MS receptacle MS 3102E-18-1P for A04 only (IP65)
C05	MS PLUG AND CABLE (IP44) CLAMP FOR G03	Straight plug MS3106A-18-1S Cable clamp 97-3057-1010-1
C27	MS PLUG FOR G15 (IP65)	MS 3106E-18-1S (IP65) Straight plug