

SIEMENS

SIMOVERT MASTERDRIVES VC Compact PLUS · 0.55 kW to 18.5 kW

Product Overview

October 2001

The proven MASTERDRIVES VC series with optimized power density.

The Compact PLUS design is ideally suited for applications where space is at a premium.

MASTERDRIVES VC Compact PLUS drives together with the 1PH7 or 1LA5/1LA7 series motors form a perfectly harmonized drive system.

Vector Control



SIMOVERT MASTERDRIVES VC Compact PLUS

The Compact PLUS design is the newest member of the SIMOVERT MASTERDRIVES VC (Vector Control) family and complements the spectrum in the lower power range. The SIMOVERT MASTERDRIVES VC power spectrum now spans from 0.55 kW to 2300 kW. The Compact PLUS series covers the power range from 0.55 kW to 18.5 kW. Larger power ratings are available in the form of compact, chassis and cabinet series units.



COMPACT PLUS



3-ph. 380-480 V

0.55-18.5 kW

COMPACT

2.2-37 kW



**3-ph. 200-230 V
3-ph. 380-480 V
3-ph. 500-600 V**

45-1500 kW

CABINET



**1-ph. 380-480 V
3-ph. 500-600 V
3-ph. 660-690 V**

22-2300 kW

CHASSIS



**3-ph. 200-230 V
3-ph. 380-480 V
3-ph. 500-600 V
3-ph. 660-690 V**

SIMOVERT MASTERDRIVES VC is the optimal drive solution for applications which place high demands on reliability and control performance. MASTERDRIVES VC Compact PLUS are the ideal drives for applications in the textile, packaging and printing industries as well as in plastics processing and manufacturing.

SIMOVERT MASTERDRIVES VC Compact PLUS

Multi-motor drive systems may be implemented with minimal wiring requirements using Compact PLUS inverters and rectifier units:

The DC link connections are realised using tinned copper bus-bars to DIN 46 433 (E-Cu 3 x 10) which are simply inserted into the terminals located on the upper side of the drives. Electrical contact is maintained via spring contacts avoiding the need for tightening screw terminals. The electronics of the rectifier and inverter units need only be supplied via an external 24 V auxiliary power supply and the multi-motor drive system is ready for operation.

Converters may be used for both single and multi-motor drive systems.

Compact PLUS converters may also be used to supply additional inverters with power and are therefore ideally suited for smaller multi-motor drive systems. The converter is used to supply the inverters with both power and 24 V DC.

System components may be used to expand the Compact PLUS drive system – also at a later date.

Energy may be stored for short periods of time using the **capacitor module**.

The **DC link module** is used for making the connection between copper bus-bar and wired DC links, e.g. for connecting other SIMOVERT MASTERDRIVES series components such as AFE compact rectifier units to the DC link of the Compact PLUS series.

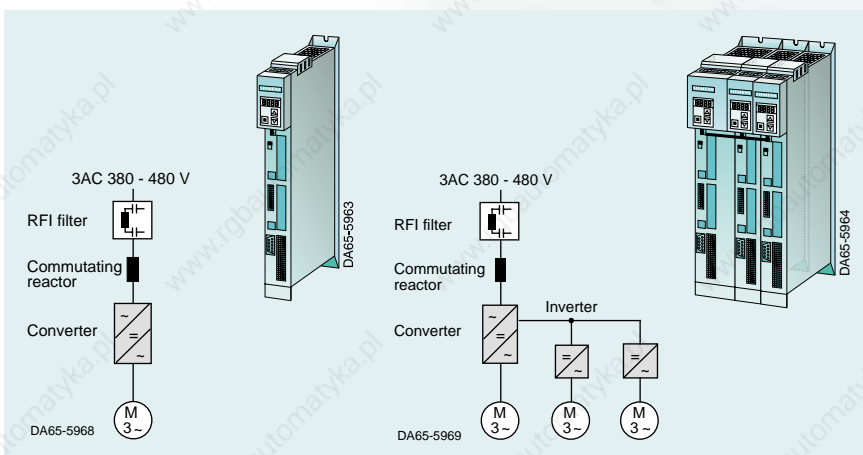
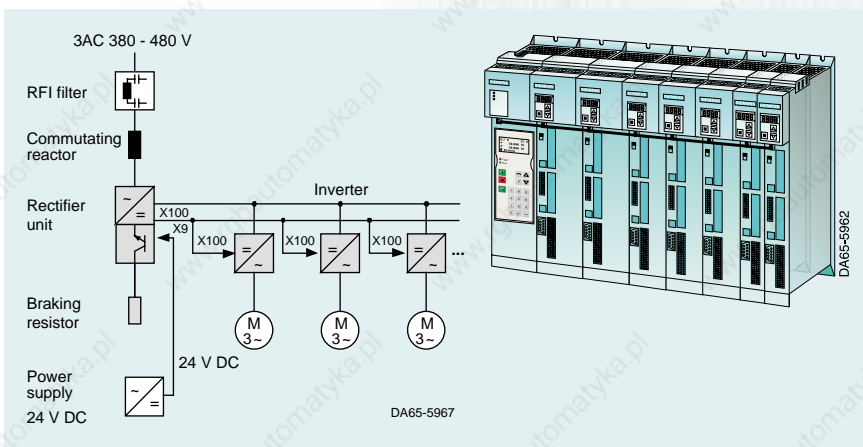

SIMOVERT MASTERDRIVES VC Compact PLUS

The **converter** has an integrated braking chopper. Only an external braking resistor is required to dissipate the braking energy generated during generative operation.

Within the compact PLUS series, additional inverters may be connected to a converter unit via the DC link bus. The sum of the nominal power ratings of the connected inverters may equal the nominal power rating of the converter, e.g. a 5.5 kW converter may supply a 4 kW inverter and additionally two 0.75 kW inverters.

A switched mode power supply is used to supply the converter control electronics from the DC link. The control electronics may also be supplied externally using a 24 V DC power supply connected to terminals X9, e.g. in order to maintain communication with a higher level control system when the power section is switched off (DC link is discharged).

The switched mode power supply of a converter is also capable of supplying the control electronics of an additional two inverters with the necessary power.

The control electronics of an **inverter** unit must always be supplied externally with 24 V DC power via the X100 terminals. The location of the X100 terminals is always identical enabling the 24 V DC power supply to be wired easily.

Unit Options

Safe STOP (K80)

With appropriate external components, unexpected starting of the drive to EN954-1 Safety Category 3 may be prevented. This option is available for all inverters and for converters from 5.5 kW nominal power rating.

Operation with non-earthed supplies (L20)

Converters without radio-interference suppression capacitors, enabling connection to IT-supply networks.

Notice:

Rectifier units and inverters are suitable for connection to IT-supply networks as standard.

The control electronics are always earthed (PELV circuit).

Converter

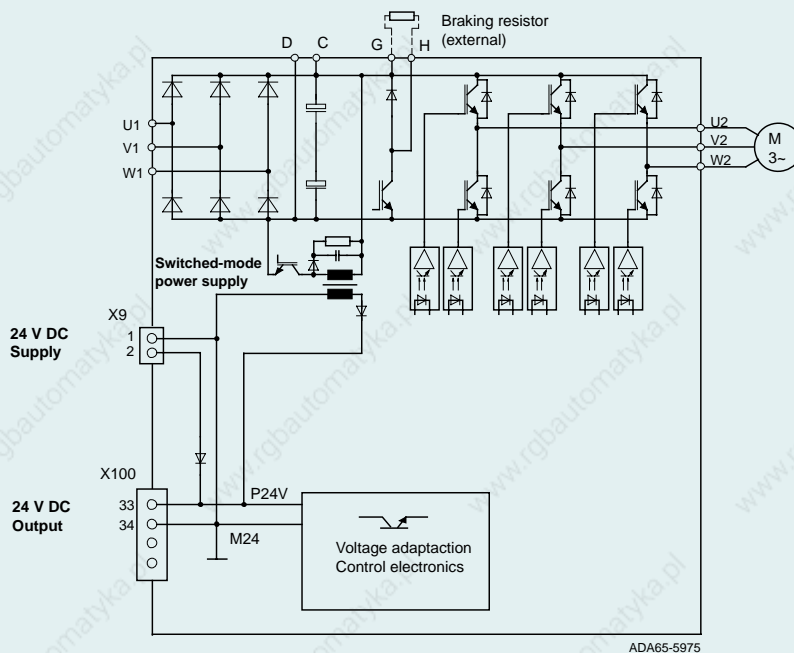

Inverter with "Safe STOP" Option

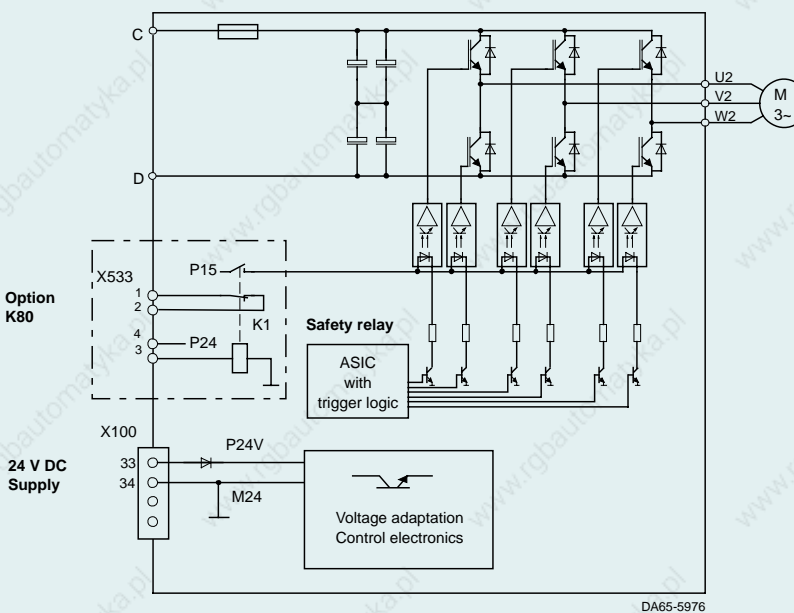

SIMOVERT MASTERDRIVES VC Compact PLUS

Option Boards for the Available Option Board Slots (Slots A and B):

COMMUNICATION BOARDS

CBP2

- Communication via PROFIBUS-DP
- The CBP2 board supports PROFIBUS Profile V3 (direct communication, acyclical communication with Master Class II)

CBC

- Communication via CAN Bus
- The CBC board supports CAN levels 1 and 2

SLB

- Fast communication between the drives via the SIMOLINK bus (fiber-optic cable) with a maximum of 201 nodes

TERMINAL EXPANSION BOARDS

EB1

- 4 bidirectional digital inputs/outputs
- 3 digital inputs
- 2 analog outputs
- 3 analog inputs

EB2

- 3 relay outputs with make contacts
- 1 relay output with change-over contact
- 2 digital inputs
- 1 analog output
- 1 analog input

PULSE ENCODER EVALUATION

SBP

- Evaluation of an external encoder or frequency generator, e.g. setpoint signal
- HTL or TTL level selectable

Notice:

All units have a HTL motor encoder input as standard.

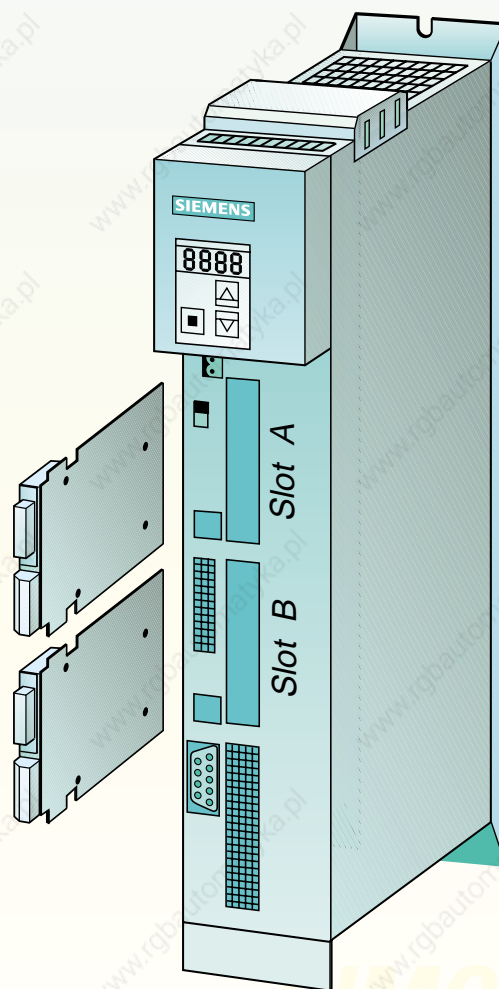

Option Board	Option Board Code	
	Slot A	Slot B
CBP2	G91	G92
CBC	G21	G22
SLB	G41	G42
EB1	G61	G62
EB2	G71	G72
SBP	C11	C12

The units are available with the required option boards factory fitted using the option codes. A maximum of 2 option boards may be installed.

For a detailed description of the option boards, please refer to Catalog DA 65.10 SIMOVERT MASTERDRIVES VC, Chapter 6.

SIMOVERT MASTERDRIVES VC Compact PLUS

The control structure of the SIMOVERT MASTERDRIVES VC is initially set in the factory and may be selected via parameter, e.g. V/f control, field oriented frequency control.

Additionally, signals may be picked-off and injected at given points. Software defined connections may be severed and new connections made. All possible thanks to **BICO Technology**.

With its free function blocks the SIMOVERT MASTERDRIVES VC is in the position to carry out simple PLC (programmable logic controller) functions. BICO Technology enables the free function blocks to be freely configured.

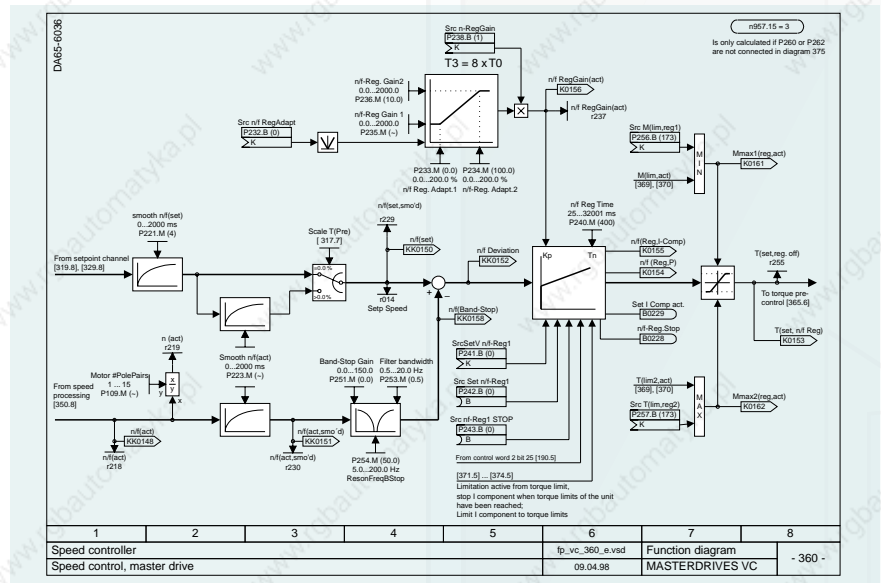

Available as free function blocks are, for example:

- fixed setpoints
- fault and alarm signal blocks
- arithmetic and control blocks
- logic blocks
- timers
- counters
- ramp-function generator
- wobble generator
- technology controller

Using BICO Technology, flexible drive solutions for all applications may be created.

With SIMOVERT MASTERDRIVES VC simple technology functions through to complex applications, e.g. winders, may be realised.

Doing away with external PLC components saves space and reduces both engineering time and costs.

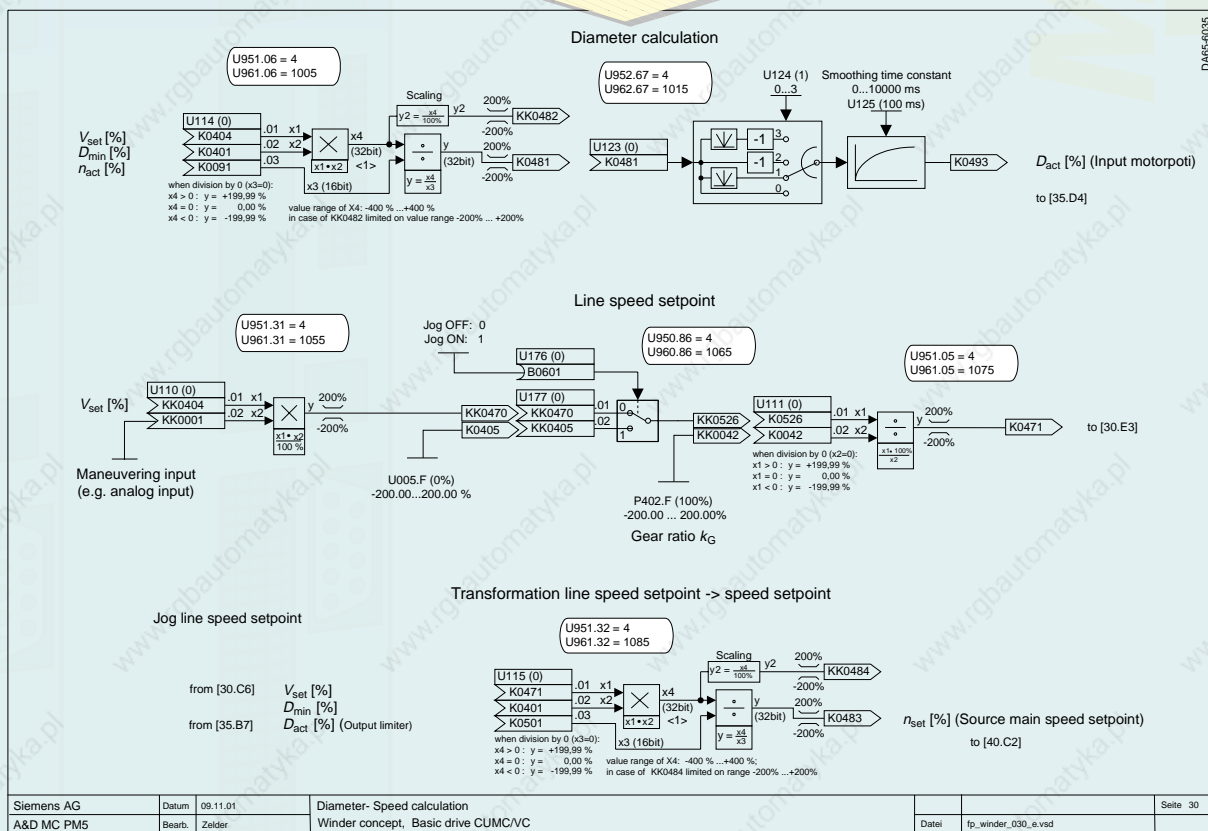
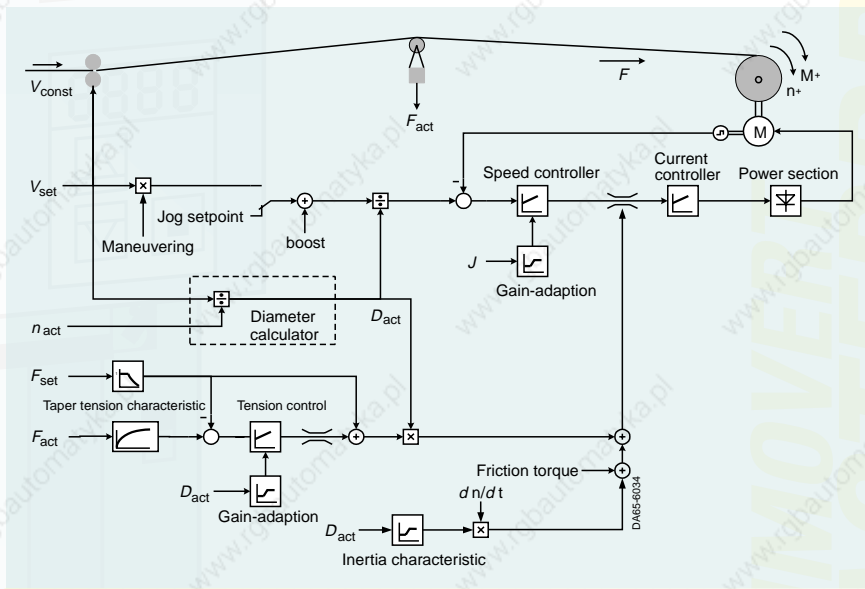

Siemens AG	Datum	09.11.01	Diameter- Speed calculation			Seite 30
A&D MC PM5	Bearb.	Zeldner	Winder concept, Basic drive CUMC/VC		Datei	fp_winder_030_e_vsd

SIMOVERT MASTERDRIVES VC Compact PLUS

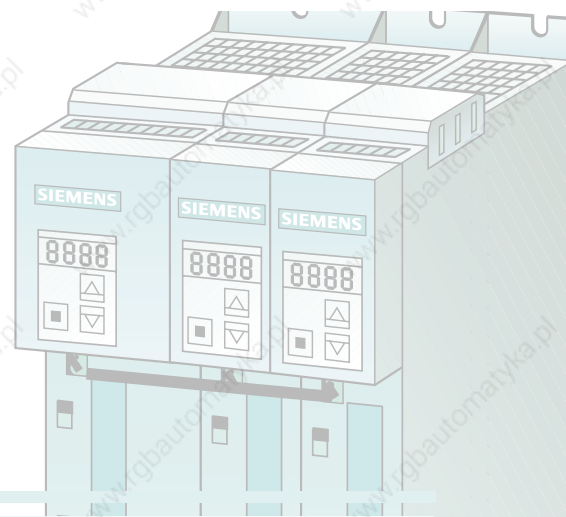

Technical Data

Rated voltage V_{Line} (DC Link Voltage)	3-ph. 380 V -15 % to 480 V +10 % (DC 510 V -15 % to 650 V +10 %)
Rated line frequency	50/60 Hz $\pm 6\%$
Efficiency (at rated load)	0.96 to 0.98
Output voltage	3-ph. 0 V to V_{Line}
Maximum output frequency V/f textile V/f characteristic and vector control mode	500 Hz 200 Hz in constant flux range 300 Hz or 5 x rated motor frequency in field weakening
Method of cooling	Forced ventilation via internal cooling fan
Permissible ambient/cooling-medium temperature during operation	0 °C to +45 °C (with derating for +45 °C < T < +50 °C)
Permissible ambient temperature during storage and transport	-25 to +70 °C
Installation altitude	≤ 1000 m above sea level (100 % load capability) > 1000 m to 4000 m above sea level (with derating)
Permissible humidity	Relative humidity $\leq 85\%$, moisture condensation not permissible
Climatic category	Class 3K3 to EN 60721-3-3
Environmental class	Class 3C2 to EN 60721-3-3
Insulation	Pollution degree 2 to HD 625.1.S1:1996 (DIN VDE 0110-1)
Overvoltage Category	Category III to HD 625.1.S1: 1996 (DIN VDE 0110-1)
Degree of protection	IP 20 to EN 60529
Protection class	Class I to DIN VDE 0106-1
Radio-interference suppression Standard Optional	To EMC product standard EN 61800-3 No radio-interference suppression Class A1/B1 (conducted)
Mechanical specifications during operation in transport	To IEC 60068-2-6 10 Hz to 58 Hz constant deflection 0.075 mm 58 Hz to 500 Hz constant acceleration 9.8 m/s ² (1 g) 5 Hz to 9 Hz constant deflection 3.5 mm 9 Hz to 500 Hz constant acceleration 9.8 m/s ² (1 g)

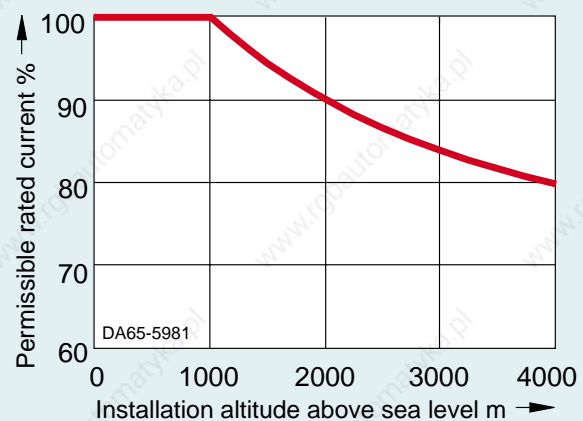
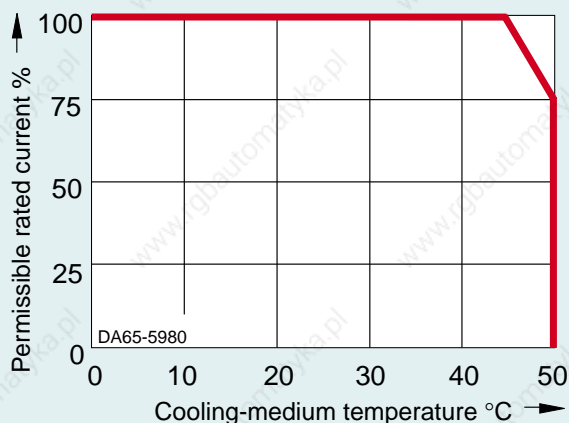

SIMOVERT MASTERDRIVES VC Compact PLUS

MASTER

Converters 3-ph. 380 V –15 % to 480 V +10 % 50/60 Hz

Nominal power rating kW	Rated output current I_n A	Short-time current ¹⁾ A	Line current *) A	Order No.	Dimensions W x H x D	Weight kg	Cooling air requirement m ³ /s	Sound press. level db (A)	
					mm				
0.55	1.5	2.4	1.7	6SE7011-5EP60	45 x 360 x 260	3.0	0.002	18	
1.1	3.0	4.8	3.3	6SE7013-0EP60	67.5 x 360 x 260	3.7	0.009	40	
1.5	5.0	8.0	5.5	6SE7015-0EP60	67.5 x 360 x 260	3.7	0.009	40	
3	8.0	12.8	8.8	6SE7018-0EP60	90 x 360 x 260	4.1	0.018	37	
4	10.0	16.0	11.0	6SE7021-0EP60	90 x 360 x 260	4.2	0.018	37	
5.5	14.0	22.4	15.4	6SE7021-4EP60	135 x 360 x 260	11.1	0.041	48	
7.5	20.5	32.8	22.6	6SE7022-1EP60	135 x 360 x 260	11.2	0.041	48	
11	27.0	43.2	29.7	6SE7022-7EP60	180 x 360 x 260	15.3	0.061	59	
15	34.0	54.4	37.4	6SE7023-4EP60	180 x 360 x 260	15.5	0.061	59	

*) Rated line current of a converter excluding additional inverters. If the converter supplies additional inverters then this value is $1.76 \times I_n$ (I_n = rated output current).

Within the compact PLUS series, additional inverters may be connected to a converter unit via the DC link bus.

The sum of the nominal power ratings of the complete system may equal twice the nominal power rating of the converter.

For the infeeding power, a coincidence factor of 0.8 must be taken into account, i.e. the rectifier of the converter is thermally designed for 1.6 times the nominal power of the converter.

The converter switched mode power supply can supply an additional 2 inverters with 24 V DC power (in the case of a 6SE7011-5EP60 converter only 1 additional inverter may be supplied).

A capacitor module may be connected to the converter for short-time energy storage.

Inverters DC 510 V –15 % to 650 V +10 %

Nominal power rating kW	Rated output current I_n A	Short-time current ¹⁾ A	DC link rated current A	Order No.	Dimensions W x H x D	Weight kg	Cooling air requirement m ³ /s	Sound press. level db (A)	Aux. current 24 V DC (max. at 20 V) A	
					mm					
0.75	2.0	3.2	2.4	6SE7012-0TP60	45 x 360 x 260	2.6	0.002	18	1.5	
1.5	4.0	6.4	4.8	6SE7014-0TP60	67.5 x 360 x 260	3.2	0.009	40	1.5	
2.2	6.1	9.8	7.3	6SE7016-0TP60	67.5 x 360 x 260	3.3	0.009	40	1.5	
4	10.2	16.3	12.1	6SE7021-0TP60	90 x 360 x 260	3.4	0.018	37	1.5	
5.5	13.2	21.1	15.7	6SE7021-3TP60	135 x 360 x 260	8.9	0.041	48	2	
7.5	17.5	28.0	20.8	6SE7021-8TP60	135 x 360 x 260	9.1	0.041	48	2	
11	25.5	40.8	30.3	6SE7022-6TP60	135 x 360 x 260	9.3	0.041	48	2	
15	34.0	54.4	40.5	6SE7023-4TP60	180 x 360 x 260	13.8	0.061	59	2	
18.5	37.5	60.0	44.6	6SE7023-8TP60	180 x 360 x 260	14.0	0.061	59	2	

1) Short-time current
 $1.6 \times I_n$ for 30 s
 $1.36 \times I_n$ for 60 s
refer to diagram on page 11

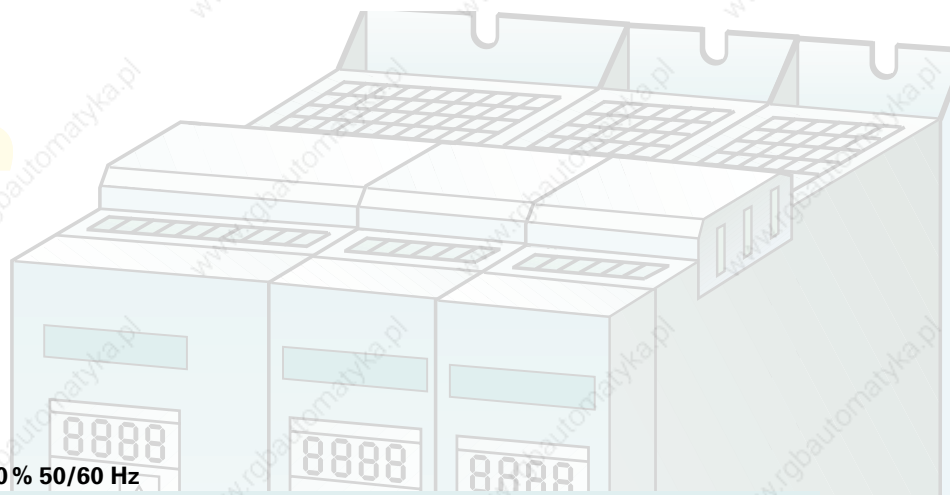

Rectifier units 3-ph. 380 V -15 % to 480 V +10 % 50/60 Hz

Nominal power rating kW	DC link rated current I_n A	Short-time current ¹⁾ A	Line current A	Order No.	Dimensions W x H x D mm	Weight kg	Cooling air requirement m ³ /s	Sound press. level db (A)	Sum of all connected Compact PLUS inverters kW	Aux. current 24 V DC (max. at 20 V) A
15	41	66	36	6SE7024-1EP85-0AA0	90 x 360 x 260	4	0.018	60	max. 30	0.5
50	120	192	108	6SE7031-2EP85-0AA0	135 x 360 x 260	10	0.041	68	max. 150	0.7
100	230 ²⁾	368	207	6SE7032-3EP85-0AA0	180 x 360 x 260	14	0.053	65	max. 300	0.7

The drive system must be engineered so that the rectifier unit will not be overloaded during operation. The rectifier unit is only capable of pre-charging a limited number of inverters and capacitor modules. The sum of the nominal power ratings of all inverters connected may not exceed the value given above. In this calculation a capacitor module counts as an inverter with nominal power rating of 45 kW. Only one capacitor module may be connected to a 15 kW rectifier unit.

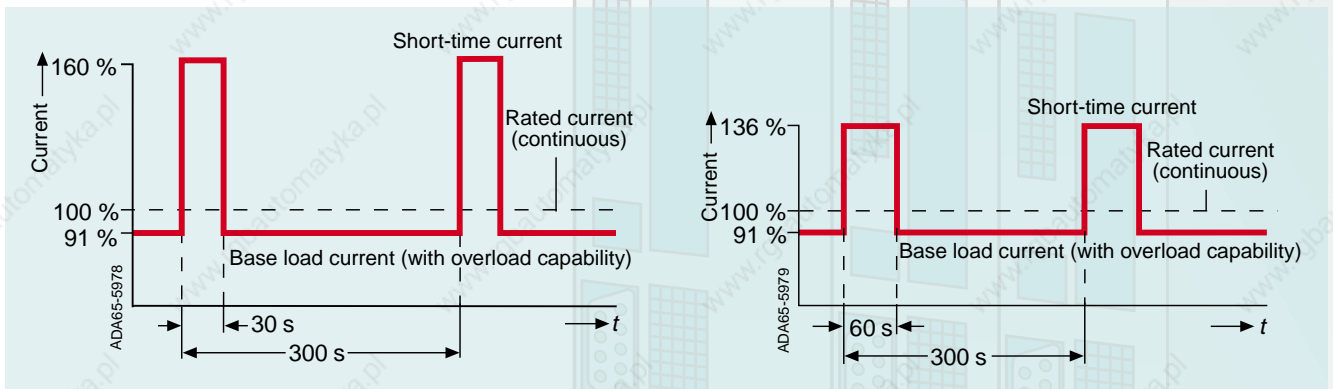

1) Short-time current
 $1.6 \times I_n$ for 30 s
 $1.36 \times I_n$ for 60 s
refer to diagram above

2) The busbars E-Cu 3x10 have a rated current of 120 A. The 100 kW rectifier unit must therefore be located in the middle of the multi-motor drive configuration, so that the DC link current is shared equally to the inverters connected to the left and the right of the rectifier unit.

SIMOVERT MASTERDRIVES VC Compact PLUS

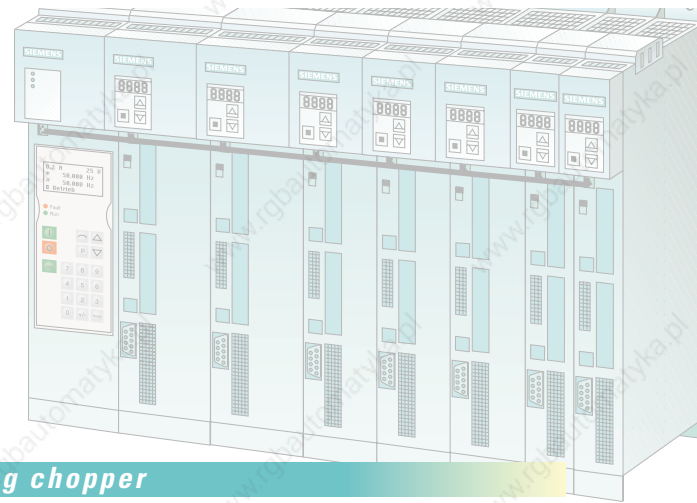

Braking power of converters with integrated braking chopper

Nominal power rating kW	Rated output current I_n A	Order No.	Smallest permissible value of external braking resistor R_{min} Ohm	Max. braking chopper current A	Rated braking power P20 with R_{min} kW	Short-time braking power P3 with R_{min} kW	Continuous braking power PDB with R_{min} kW
0.55	1.5	6SE7011-5EP60	80	10	5	7.5	1.25
1.1	3.0	6SE7013-0EP60	80	10	5	7.5	1.25
1.5	5.0	6SE7015-0EP60	80	10	5	7.5	1.25
3	8.0	6SE7018-0EP60	40	20	10	15	2.5
4	10.0	6SE7021-0EP60	40	20	10	15	2.5
5.5	14.0	6SE7021-4EP60	20	40	20	30	5
7.5	20.5	6SE7022-1EP60	20	40	20	30	5
11	27.0	6SE7022-7EP60	11	70	36	54	9
15	34.0	6SE7023-4EP60	11	70	36	54	9

Braking power of rectifier units with integrated braking chopper

Nominal power rating kW	DC link rated current I_n A	Order No.	Smallest permissible value of external braking resistor R_{min} Ohm	Max. braking chopper current A	Rated braking power P20 with R_{min} kW	Short-time braking power P3 with R_{min} kW	Continuous braking power PDB with R_{min} kW
15	41	6SE7024-1EP85-0AA0	19	40	20	30	5
50	120	6SE7031-2EP85-0AA0	6.5	120	60	90	15
100	230	6SE7032-3EP85-0AA0	3.4	230	116	174	29

Connecting an external braking resistor to a rectifier unit or converter enables generative operation. The energy generated is dissipated in the form of heat via a braking resistor. To prevent overheating of electronic components in the control cabinet, it is recommended that the braking resistor be mounted outside of the control cabinet.

To prevent the braking chopper from being electrically overloaded, the resistance of the braking resistor should not be smaller than the minimum permissible value stated. The control electronics monitor the status of the braking chopper, switching it off in the case of overload.

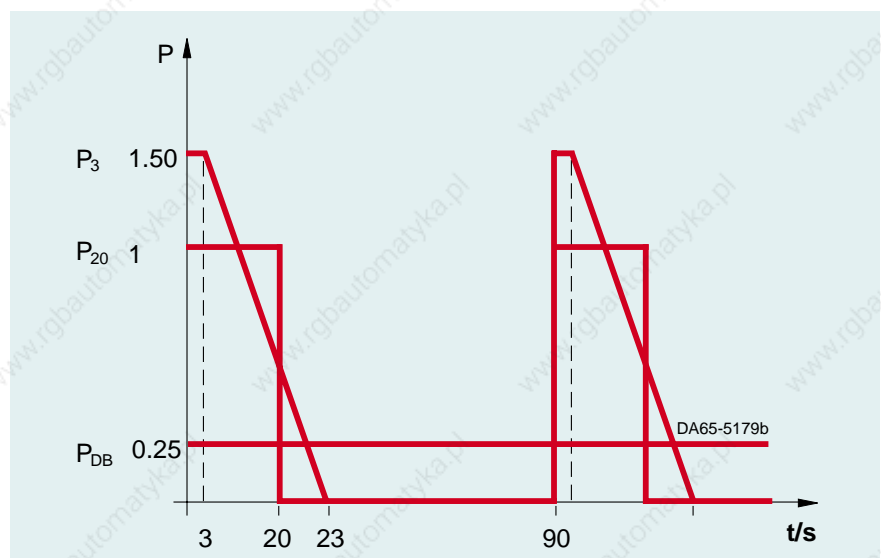

SIMOVERT MASTERDRIVES VC Compact PLUS

SIMOVERT MASTERDRIVES VC

System components

DC link connection

The DC link connection is made using three busbars: positive-connection (C), negative-connection (D) and protective earth (PE). Copper busbar E-Cu 3x10 tinned and rounded according to DIN 46 433, rated current 120 A (e.g. Siemens 8WA2 842 length 1 m, or Phoenix Contact GmbH & Co., type NLS-Cu 3/10 Internet: www.phoenixcontact.com)

Braking resistors

Rated braking power P20 kW	Short-time braking power P3 kW	Continuous braking power PDB kW	Resistance Ohm	Order No.	Dimensions W x H x D mm	Weight kg
5	7.5	1.25	80	6SE7018-0ES87-2DC0	145 x 180 x 540	6
10	15	2.5	40	6SE7021-6ES87-2DC0	145 x 360 x 540	12
20	30	5	20	6SE7023-2ES87-2DC0	450 x 305 x 485	17
50	75	12.5	8	6SE7028-0ES87-2DC0	745 x 305 x 485	27
100	150	25	4	6SE7031-6ES87-2DC0	745 x 605 x 485	47

Capacitor module

Capacitance mF	max. DC link voltage continuous V	short-time V	Order No.	Dimensions W x H x D mm	Weight kg
5.1	715	780	6SE7025-0TP87-2DD0	90 x 360 x 260	6

DC link module

Continuous current A	Voltage range	Order No.	Dimensions W x H x D mm	Weight kg
120	510 V DC -15% to 650 V +10%	6SE7090-0XP87-3CR0	90 x 360 x 260	2.6

Radio interference suppression filters

Rated current A	Integrated line reactor 2% u_k	Limit-value class	Typ. power loss W	Order No.	Weight kg
2	yes	B1	5	6SE7012-0EP87-0FB0	2
6	yes	B1	13	6SE7016-0EP87-0FB0	3.5
12	yes	B1	23	6SE7021-2EP87-0FB0	5.5
18	yes	B1	26	6SE7021-8EP87-0FB0	7.5
36	no	B1	30	6SE7023-4ES87-0FB1	4
80	no	B1	40	6SE7027-2ES87-0FB1	10
190	no	A1	70	6SE7031-8ES87-0FA0	13
320	no	A1	100	6SE7033-2ES87-0FA1	21

Commutating reactors 2% u_k

Rated current A	Power loss 50/60 Hz W	Order No.	Weight approx. kg	Rated current A	Power loss 50/60 Hz W	Order No.	Weight approx. kg
1.5	8/10	4EP3200-4US	1	35.5	57/60	4EP3700-2US	4
3	12/18	4EP3200-5US	1	40	57/60	4EP3700-5US	4
5	23/35	4EP3200-2US	1	50	67/71	4EP3800-2US	5
9.1	35/38	4EP3400-2US	1.5	63	67/71	4EP3800-7US	5
11.2	35/38	4EP3400-1US	1.5	80	82/87	4EP3900-2US	6.5
16	45/48	4EP3500-0US	2	125	96/103	4EP4000-6US	10
18	52/57	4EP3600-4US	3	224	190/200	4EU2552-8UA00-0A	16.5
28	52/57	4EP3600-5US	3				

SIMOVERT MASTERDRIVES VC Compact PLUS

Motor selection (preferred motor types)



1PH7 asynchronous servomotors

Converter/ Inverter	Nominal power rating kW	Rated current A	Rated speed			
			1150 1/min	1750 1/min	2300 1/min	
Converter	6SE7011-5EP60	0.55	1.5			
	6SE7013-0EP60	1.1	3.0			
	6SE7015-0EP60	1.5	5.0			
	6SE7018-0EP60	3	8.0			
	6SE7021-0EP60	4	10.0	1PH7103-2□D00-0BA3	1PH7101-2□F00-0BA3	
	6SE7021-4EP60	5.5	14.0	1PH7103-2□D00-0BA3	1PH7103-2□F00-0BA3	
	6SE7022-1EP60	7.5	20.5	1PH7107-2□D00-0BA3	1PH7105-2□F00-0BA3	1PH7103-2□G00-0BA3
	6SE7022-7EP60	11	27.0	1PH7107-2□D00-0BA3	1PH7131-2□F00-0BA3	1PH7107-2□G00-0BA3
	6SE7023-4EP60	15	34.0	1PH7133-2□D00-0BA3	1PH7133-2□F00-0BA3	1PH7107-2□G00-0BA3
Inverter	6SE7012-0TP60	0.75	2.0			
	6SE7014-0TP60	1.5	4.0			
	6SE7016-0TP60	2.2	6.1			
	6SE7021-0TP60	4	10.2	1PH7103-2□D00-0BA3	1PH7101-2□F00-0BA3	
	6SE7021-3TP60	5.5	13.2	1PH7103-2□D00-0BA3	1PH7103-2□F00-0BA3	
	6SE7021-8TP60	7.5	17.5	1PH7107-2□D00-0BA3	1PH7105-2□F00-0BA3	1PH7103-2□G00-0BA3
	6SE7022-6TP60	11	25.5	1PH7107-2□D00-0BA3	1PH7131-2□F00-0BA3	1PH7107-2□G00-0BA3
	6SE7023-4TP60	15	34.0	1PH7133-2□D00-0BA3	1PH7133-2□F00-0BA3	1PH7107-2□G00-0BA3
	6SE7023-8TP60	18.5	37.5	1PH7133-2□D00-0BA3	1PH7133-2□F00-0BA3	1PH7107-2□G00-0BA3

For further 1PH7 motor technical data, please refer to catalog DA 65.3

A without encoder

H with ROD 431 pulse encoder (1024 ppr)



1LA5/1LA7 three-phase low-voltage motors

Converter/ Inverter	Nominal power rating kW	Rated current A	Rated speed			
			1000 1/min	1500 1/min	3000 1/min	
Converter	6SE7011-5EP60	0.55	1.5	1LA7080-6AA..	1LA7080-4AA..	1LA7073-2AA..
	6SE7013-0EP60	1.1	3.0	1LA7096-6AA..	1LA7090-4AA..	1LA7083-2AA..
	6SE7015-0EP60	1.5	5.0	1LA7113-6AA..	1LA7106-4AA..	1LA7096-2AA..
	6SE7018-0EP60	3	8.0	1LA7130-6AA..	1LA7113-4AA..	1LA7113-2AA..
	6SE7021-0EP60	4	10.0	1LA7133-6AA..	1LA7113-4AA..	1LA7130-2AA..
	6SE7021-4EP60	5.5	14.0	1LA7134-6AA..	1LA7130-4AA..	1LA7131-2AA..
	6SE7022-1EP60	7.5	20.5	1LA7163-6AA..	1LA7133-4AA..	1LA7163-2AA..
	6SE7022-7EP60	11	27.0	1LA7166-6AA..	1LA7163-4AA..	1LA7164-2AA..
	6SE7023-4EP60	15	34.0	1LA5186-6AA..	1LA7166-4AA..	1LA7166-2AA..
Inverter	6SE7012-0TP60	0.75	2.0	1LA7090-6AA..	1LA7083-4AA..	1LA7080-2AA..
	6SE7014-0TP60	1.5	4.0	1LA7106-6AA..	1LA7096-4AA..	1LA7090-2AA..
	6SE7016-0TP60	2.2	6.1	1LA7113-6AA..	1LA7106-4AA..	1LA7106-2AA..
	6SE7021-0TP60	4	10.2	1LA7133-6AA..	1LA7113-4AA..	1LA7130-2AA..
	6SE7021-3TP60	5.5	13.2	1LA7134-6AA..	1LA7130-4AA..	1LA7131-2AA..
	6SE7021-8TP60	7.5	17.5	1LA7163-6AA..	1LA7133-4AA..	1LA7131-2AA..
	6SE7022-6TP60	11	25.5	1LA7166-6AA..	1LA7163-4AA..	1LA7163-2AA..
	6SE7023-4TP60	15	34.0	1LA5186-6AA..	1LA7166-4AA..	1LA7166-2AA..
	6SE7023-8TP60	18.5	37.5	1LA5206-6AA..	1LA5183-4AA..	1LA7166-2AA..

For further 1LA5/1LA7 motor technical data, please refer to catalog M11

All motors are also available with 1XP8001-1 incremental pulse encoder (1024 ppr)

SIMOVERT MASTERDRIVES VC Compact PLUS

Dimensions

Converter and Inverter

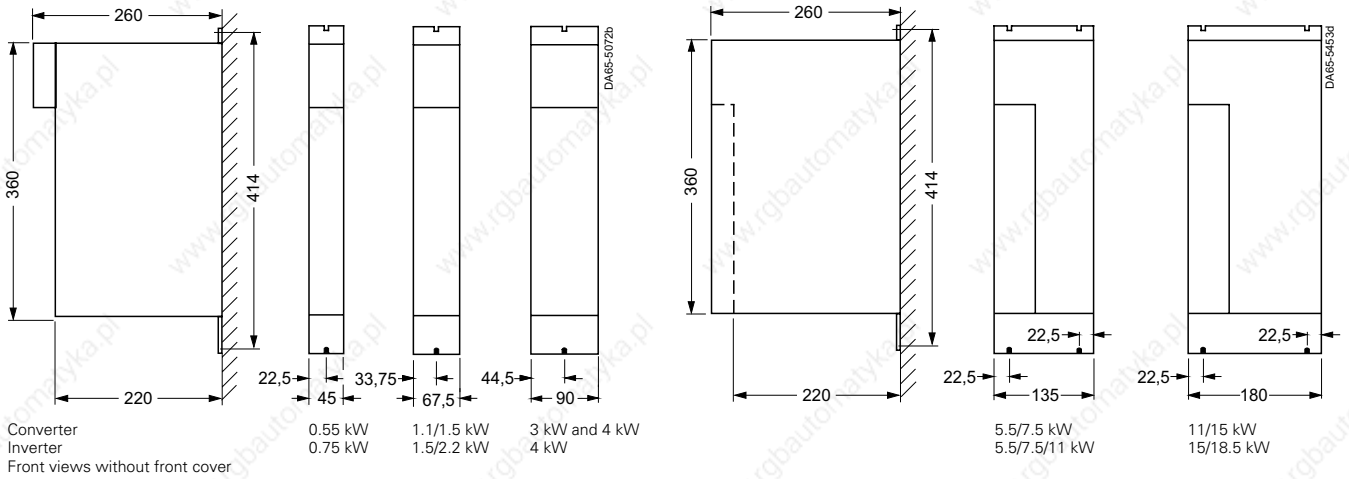

Rectifier units

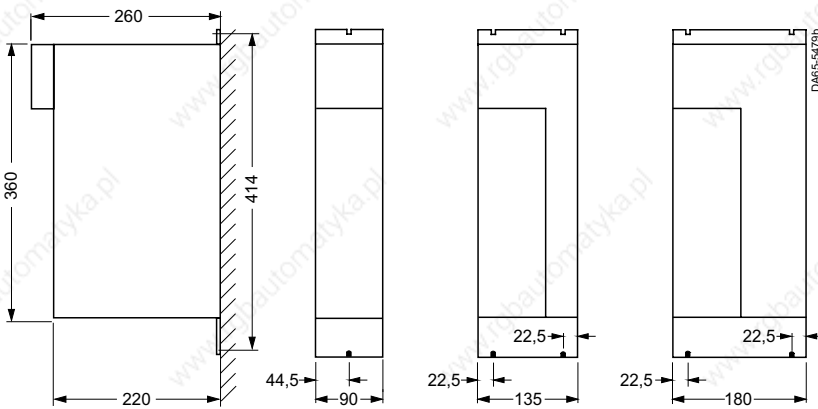

Front views without front cover

DC link and capacitor module

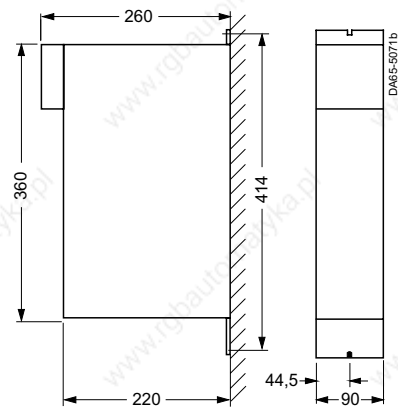

SIMOVERT MASTERDRIVES VC Compact PLUS

Braking resistors

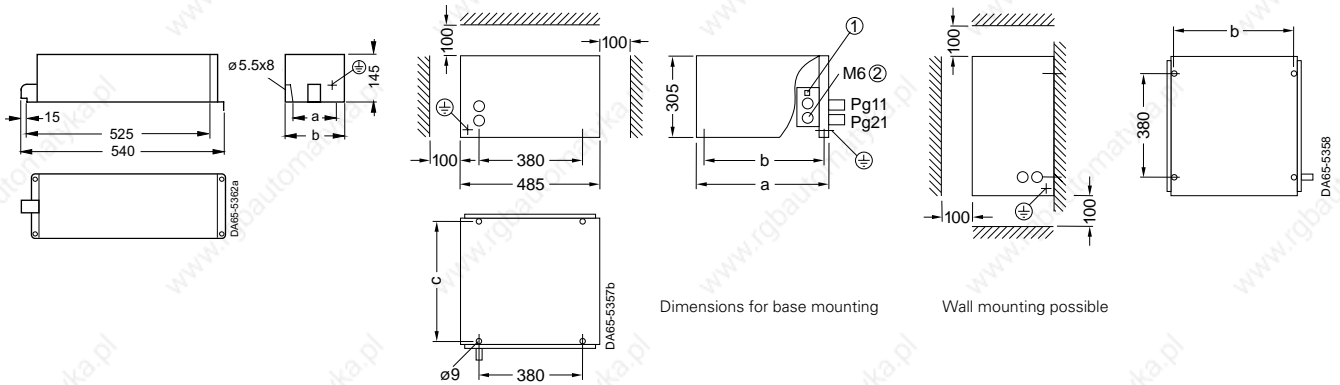

Braking resistor 5 kW and 10 kW

Type	a	b
6SE7018-0ES87-2DC0	150	180
6SE7021-6ES87-2DC0	330	360

Braking resistor 20 kW and 50 kW

Type	a	b	c
6SE7023-2ES87-2DC0	430	400	400
6SE7028-0ES87-2DC0	740	710	710

- ① T1/T2 socket terminal
- ② Stud terminal

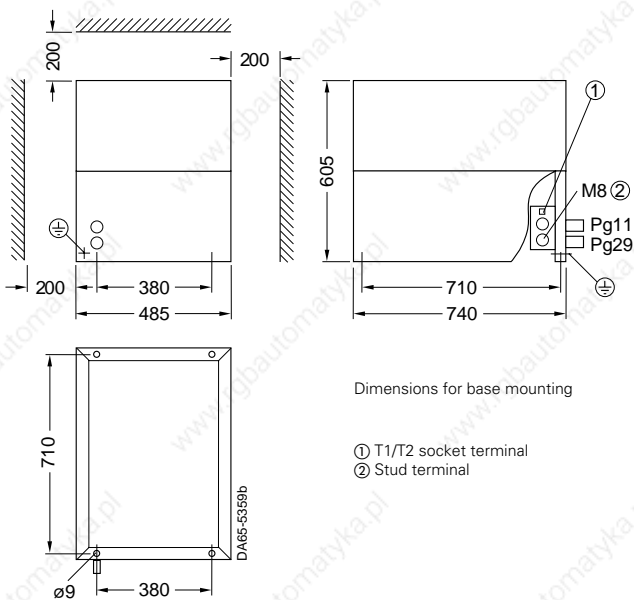

Braking resistor 100 kW
6SE7031-6ES87-2DC0

- ① T1/T2 socket terminal
- ② Stud terminal

SIMOVERT MASTERDRIVES VC Compact PLUS

Radio interference suppression filters

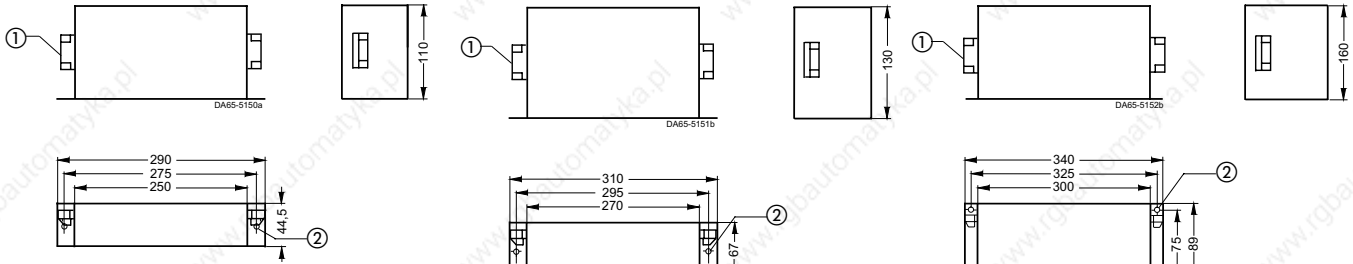

6SE7012-0EP87-0FB0

6SE7016-0EP87-0FB0

6SE7021-2EP87-0FB0
6SE7021-8EP87-0FB0

- ① Power COMBICON
- ② Oblong hole 5.5 x 7.5

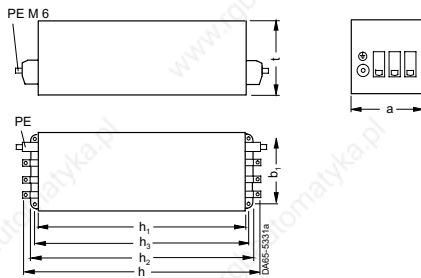

6SE7023-4ES87-0FB1
6SE7027-2ES87-0FB1

Type	a	b ₁	h	h ₁	h ₂	h ₃	t	Terminals	Earthing stud
6SE7023-4ES87-0FB1	101	85	231	166	196	182	86	16 mm ²	M6
6SE7027-2ES87-0FB1	141	120	308	221	256	240	141	50 mm ²	M10

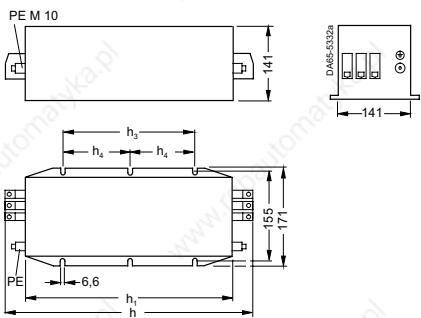

6SE7031-8ES87-0FA0

h	h ₁	h ₃	h ₄	Terminals
404	301	165	82.5	95 mm ²

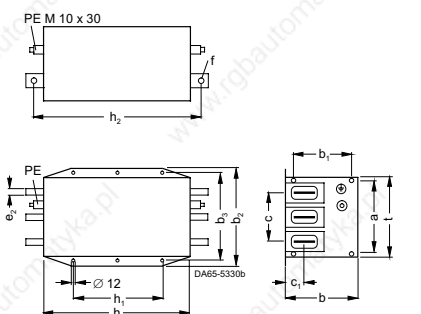

6SE7033-2ES87-0FA1

a	b	b ₁	b ₂	b ₃	c	c ₁	e	e ₁	e ₂	f	h	h ₁	h ₂	t
180	116	85	260	235	120	36	15	25	5	∅11	300	240	360	210

SIMOVERT MASTERDRIVES VC Compact PLUS

Commutating reactors

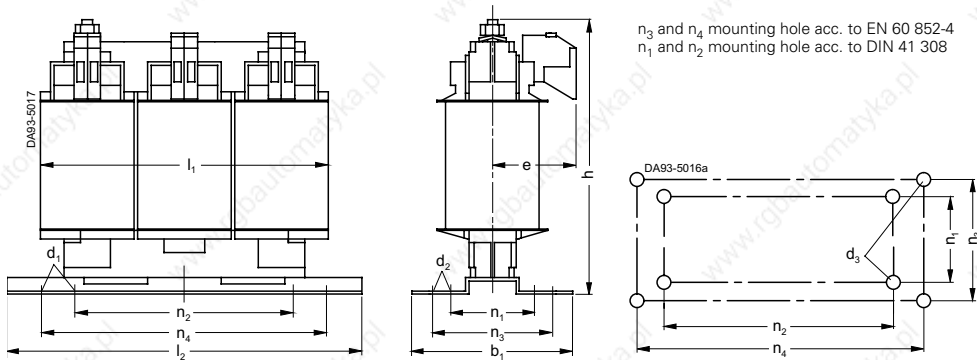

Screw terminal 8WA9 200
(for $I_{LN} \leq 15$ A)

Solid 0.5 mm² to 6.0 mm²
Finely stranded 1.5 mm² to 4.0 mm²

Screw terminal RKW 110 or
TRKSD 10 (for I_{LN} 16 A to 35.5 A)

Solid 1.0 mm² to 16.0 mm²
Finely stranded 1.0 mm² to 10.0 mm²

Earthing stud M 6 x 12

Solid 2.5 mm² to 10.0 mm²
Finely stranded 4.0 mm² to 10.0 mm²

4EP, $I_{LN} \leq 35.5$ A

Type	b ₁	d ₁	d ₂	d ₃	e	h	l ₁	l ₂	n ₁	n ₂	n ₃	n ₄
4EP32	57.5	4.8	9	M4	56	108	78	88.5	34	¹⁾	42.5	79.5
4EP34	73	4.8	9	M4	59	122	96	124	42	¹⁾	53	112
4EP35	68	4.8	9	M4	57	139	120	148	39	90	48	136
4EP36	78	4.8	9	M4	62	139	120	148	49	90	58	136
4EP37	73	5.8	11	M5	60	159	150	178	49	113	53	166

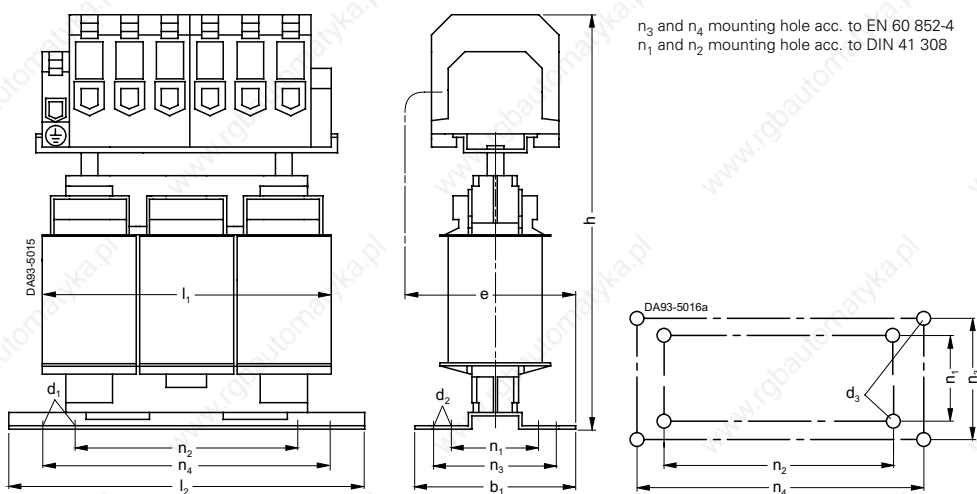

Screw terminal RKW 110
or TRKSD 10 (for $I_{LN} \leq 40$ A)

Solid 1.0 mm² to 16.0 mm²
Finely stranded 1.0 mm² to 10.0 mm²

Earthing stud M 6 x 12

Solid 2.5 mm² to 10.0 mm²
Finely stranded 4.0 mm² to 10.0 mm²

Screw terminal 8WA1 304
(for I_{LN} 40 A to 50 A)

Solid 1.0 mm² to 16.0 mm²
Stranded 10.0 mm² to 25.0 mm²
Finely stranded 2.5 mm² to 16.0 mm²

Earthing terminal
EK 16/35

Solid 2.5 mm² to 16.0 mm²
Finely stranded 4.0 mm² to 16.0 mm²

4EP, $I_{LN} \leq 36$ A to 50 A

Type	b ₁	d ₁	d ₂	d ₃	e	h	l ₁	l ₂	n ₁	n ₂	n ₃	n ₄
4EP38	88	5.8	11	M5	86	193	150	178	64	113	68	166

SIMOVERT MASTERDRIVES VC Compact PLUS

Commutating reactors

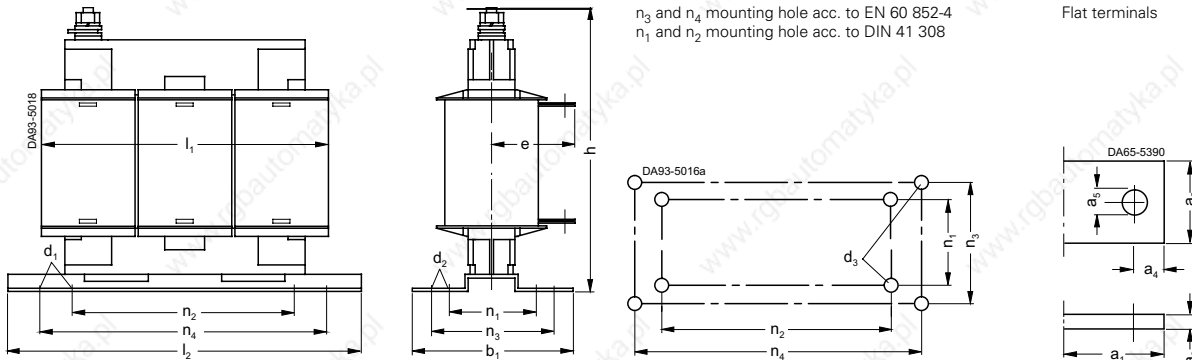

4EP, $I_{LN} \geq 51$ A

Type	b_1	d_1	d_2	d_3	e	h	l_1	l_2	n_1	n_2	n_3	n_4
4EP38	88	5.8	11	M5	76	153	150	178	64	113	68	166
4EP39	99	7	13	M6	73	179	182	219	56	136	69	201
4EP40	119	7	13	M6	83	179	182	219	76	136	89	201

Rated current I_{LN} A	a_1	a_2	a_3	a_4	a_5
51 to 80	30	20	3	10	9
81 to 200	35	25	5	12.5	11

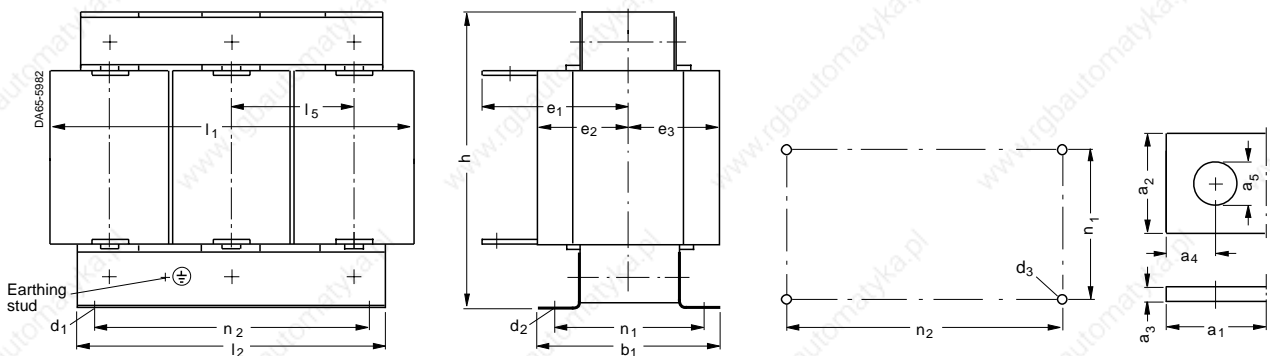

4EU2552-8UA00-0A

Type	b_1	d_1	d_2	d_3	e_1 max.	e_2 max.	e_3 max.	h max.	l_1	l_2	n_1	n_2	l_5	Earthing stud	a_1	a_2	a_3	a_4	a_5
4EU25	115	7	13	M6	118.5	72.5	60.5	210	225	190	94	176	76	M6	30	30	6	15	14

**Additional information about SIMOVERT MASTERDRIVES
can be found in our Catalogs DA 65.10 and DA 65.11**



Information about this
product can be
found in the Internet
under:

<http://www.siemens.de/automation/mc>

Siemens AG
Automation and Drives Group
Motion Control Systems
P.O. Box 32 69, 91050 Erlangen
Federal Republic of Germany

Siemens Aktiengesellschaft

© Siemens AG 2001
Subject to change without prior notice

Order No. 6ZB5711-0AA02-0BA0
Printed in the Federal Republic of Germany
18401/222198 SV 1101 4.0

