

AC SERVO DRIVES

R, P SERIES FOR SPEED CONTROL

SERVOMOTOR : TYPES USAREM, USAPEM (with Optical Encoder)

SERVOPACK : TYPES CACR-SR: AC (Rack-mounted Type)

CACR-SR: AE (Rack-mounted Type)

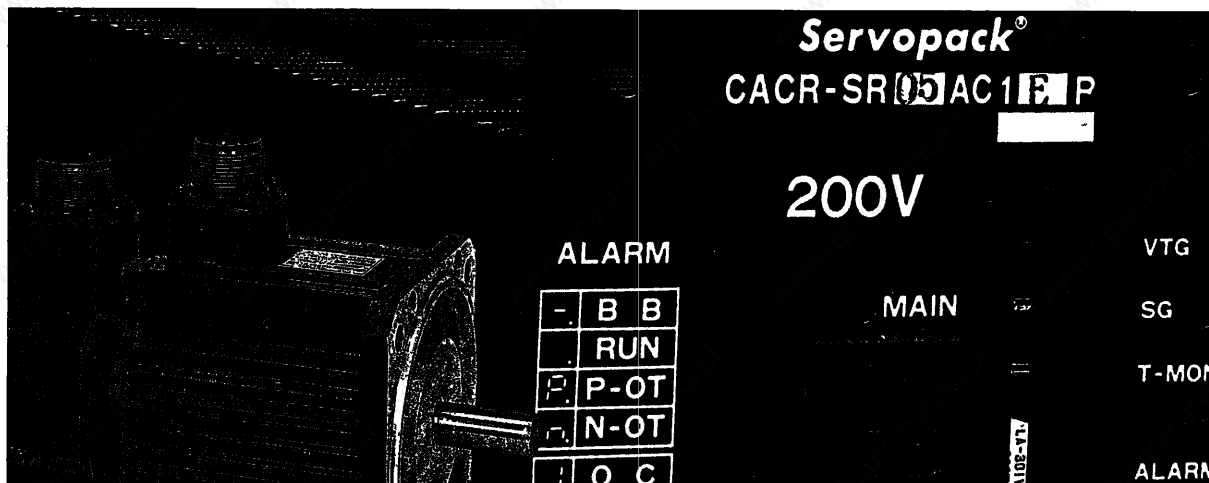

YASKAWA

YASKAWA AC Servo Drives have been developed as the basic mechatronics drives for the most advanced FA and FMS, including robots and machine tools.

Yaskawa takes great pride in introducing the P series as the latest addition to the R series AC Servo Drives which have enjoyed an outstanding reputation among their users.

The R and P series achieves lower cost and smaller size in spite of high speed operation and high reliability. Originally designed for point-to-point positioning, it has been found in such applications as assembly robots, chip mounters, small-type X-Y tables, coil winding machines, etc.

FEATURES

- High speed operation possible
- High accuracy and quick response for speed control even under adverse environmental conditions
- Compact design and light weight
- User-friendly protective functions with LED alarm indications

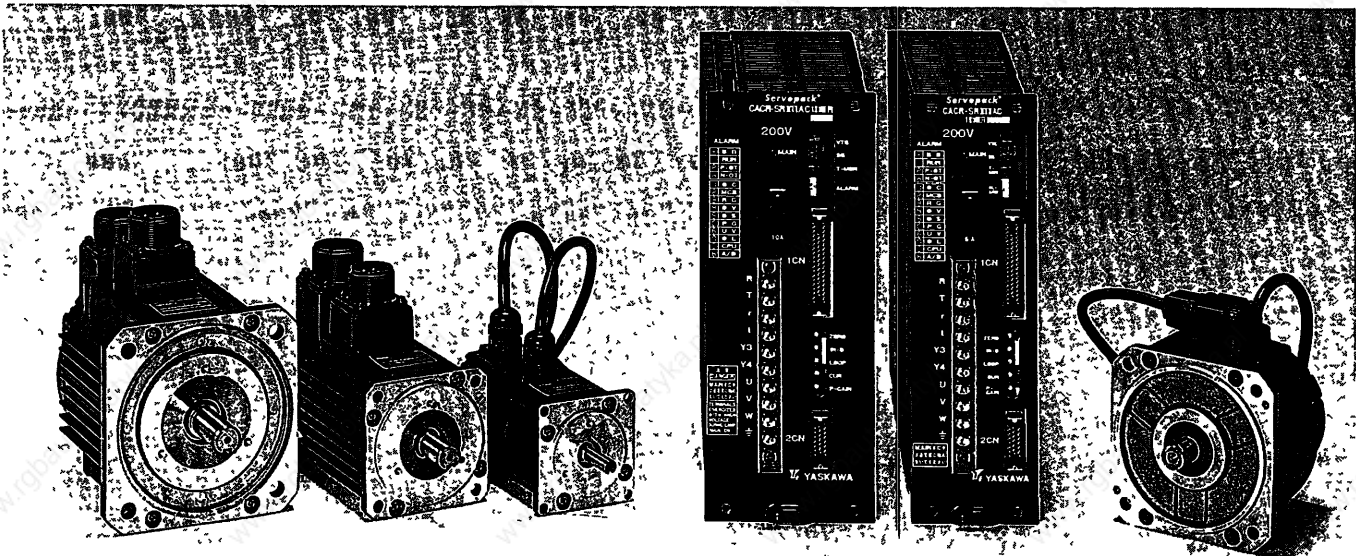

CONTENTS

1. RATINGS AND SPECIFICATIONS	1	6 5 PROTECTIVE CIRCUIT	34
1. 1 RATINGS AND SPECIFICATIONS OF R SERIES AC SERVOMOTORS (FOR 200 V)	1	6. 6 LED INDICATION	35
1. 2 RATINGS AND SPECIFICATIONS OF R SERIES AC SERVOMOTORS (FOR 100 V)	4	6. 7 PRECAUTIONS FOR APPLICATION	35
1. 3 RATINGS AND SPECIFICATIONS OF P SERIES AC SERVOMOTORS (FOR 200 V)	7	6. 8 PRECAUTIONS OF OPERATION	35
1. 4 RATINGS AND SPECIFICATIONS OF SERVOPACK	10	6. 9 APPLICATION	37
2. TYPE DESIGNATION	13	7. INSTALLATION AND WIRING	38
3. LIST OF STANDARD COMBINATION	14	7. 1 RECEIVING	38
4. CHARACTERISTICS	16	7. 2 INSTALLATION	38
4. 1 OVERLOAD CHARACTERISTICS	16	7. 3 WIRING	39
4. 2 STARTING AND STOPPING TIME	16	8. DIMENSIONS	41
4. 3 ALLOWABLE FREQUENCY OF OPERATION	17	8. 1 SERVOMOTOR DIMENSIONS	41
4. 4 SERVOMOTOR FREQUENCY	18	8. 2 SERVOPACK DIMENSIONS	49
4. 5 MOTOR SPEED-REFERENCE INPUT CHARACTERISTICS	18	8. 3 PERIPHERAL EQUIPMENT	54
4. 6 MOTOR MECHANICAL CHARACTERISTICS	18	9. TEST RUN	55
5. CONFIGURATION	21	9. 1 CHECK ITEMS BEFORE TEST RUN	55
5. 1 CONNECTION DIAGRAM	21	9. 2 TEST RUN PROCEDURES	55
5. 2 INTERNAL BLOCK DIAGRAM	22	10. ADJUSTMENT	56
5. 3 MAIN-CIRCUIT TERMINALS	23	10. 1 SETTINGS AT THE TIME OF DELIVERY	56
5. 4 CONNECTOR TERMINAL (1CN) FOR I/O SIGNAL	23	10. 2 CHARACTERISTICS AT THE TIME OF DELIVERY	60
5. 5 CONNECTOR TERMINAL (2CN) FOR OPTICAL ENCODER (PG) CONNECTION	26	10. 3 READJUSTMENT	60
6. OPERATION	29	10. 4 ADJUSTMENT PROCEDURES	60
6. 1 POWER ON AND OFF	29	10. 5 SWITCH SETTING	63
6. 2 SPEED REFERENCE	30	11. INSPECTION AND MAINTENANCE	64
6. 3 EXTERNAL CURRENT LIMIT REFERENCE CIRCUIT [P-CL, N-CL]	31	11. 1 AC SERVOMOTOR	64
6. 4 CONFIGURATION OF I/O CIRCUIT	32	11. 2 SERVOPACK	64
		12. TROUBLESHOOTING GUIDE	65
		12. 1 AC SERVOMOTOR	65
		12. 2 SERVOPACK	66

INDEX

Subject	Chapter	Section No.	Page
A AC SERVOMOTOR (Inspection and maintenance)	11	11.1	64
AC SERVOMOTOR (Troubleshooting guide)	12	12.1	65
ADJUSTMENT	10		56
ADJUSTMENT PROCEDURES	10	10.4	62
ALLOWABLE FREQUENCY OF OPERATION	4	4.3	17
Allowable Radial Load and Thrust Load	4	4.6.2	18
APPLICATION	6	6.9	37
Auxiliary Input Circuit (± 2 to $\pm 10V$)	6	6.2.4	30
C CHARACTERISTICS	4		16
CHARACTERISTICS AT THE TIME OF DELIVERY	10	10.2	60
CHECK ITEMS BEFORE TEST RUN	9	9.1	55
CONFIGURATION	5		21
CONFIGURATION OF I/O CIRCUIT	6	6.4	32
CONNECTION DIAGRAM	5	5.1	21
Connection for Reverse Motor Running	6	6.9.1	37
Connector 1CN Layout and Connection of SERVOPACK	5	5.4.2	23
CONNECTOR TERMINAL (1CN) FOR I/O SIGNAL	5	5.4	23
CONNECTOR TERMINAL (2CN) FOR OPTICAL ENCODER (PG) CONNECTION	5	5.5	26
Current Limit when Motor is Locked	6	6.3.3	31
D DIMENSIONS	8		41
Direction of Rotation	4	4.6.4	19
E Examples of Troubleshooting for Defective Wiring or Parts	12	12.2.2	67
Examples of Troubleshooting for Incomplete Adjustment	12	12.2.3	67
EXTERNAL CURRENT LIMIT REFERENCE CIRCUIT [P-CL, N-CL]	6	6.3	31
H Handling of Speed Reference Input Terminal	6	6.2.3	30
High Voltage Line	6	6.7.3	35
I Impact Resistance	4	4.6.5	20
Input Circuit	6	6.4.1	32
INSPECTION AND MAINTENANCE	11		64
Inspection during Test Run	9	9.2.3	55
INSTALLATION	7	7.2	38
INSTALLATION AND WIRING	7		38
INTERNAL BLOCK DIAGRAM	5	5.2	22
L LED INDICATION	6	6.6	35
LED Indication (7-segment) for troubleshooting	12	12.2.1	66
LIST OF STANDARD COMBINATION	3		14
Load Inertia (GD^2)	6	6.7.2	35
M MAIN-CIRCUIT TERMINALS	5	5.3	23
Mechanical Specifications	4	4.6.3	18
Mechanical Strength	4	4.6.1	18
Method of Giving External Current Limit Reference	6	6.3.1	31
MOTOR MECHANICAL CHARACTERISTICS	4	4.6	18
MOTOR SPEED-REFERENCE INPUT CHARACTERISTICS	4	4.5	18
N Noise Control	6	6.8.1	35
O OPERATION	6		29
Optical Encoder (PG) Output Circuit [PAO, *PAO, PBO, *PBO, PCO, *PCO]	6	6.4.3	33
Output Circuit	6	6.4.2	32
Overhanging Loads	6	6.7.1	35
OVERLOAD CHARACTERISTICS	4	4.1	16

INDEX

Subject	Chapter	Section No.	Page
P PERIPHERAL EQUIPMENT	8	8.3	54
Power Line Protection	6	6.8.2	37
Power Loss	7	7.3.3	40
POWER ON AND OFF	6	6.1	29
PRECAUTIONS FOR APPLICATION	6	6.7	35
PRECAUTIONS OF OPERATION	6	6.8	35
Preparation of Test Run Operation	9	9.2.1	55
PROTECTIVE CIRCUIT	6	6.5	34
R R Series AC SERVOMOTOR	8	8.1.1	41
Rated Current and Cable Size	7	7.3.1	39
RATINGS AND SPECIFICATIONS	1		1
RATINGS AND SPECIFICATIONS OF P SERIES AC SERVOMOTORS (FOR 200V)	1	1.3	7
RATINGS AND SPECIFICATIONS OF R SERIES AC SERVOMOTORS (FOR 100V)	1	1.2	4
RATINGS AND SPECIFICATIONS OF R SERIES AC SERVOMOTORS (FOR 200V)	1	1.1	1
RATINGS AND SPECIFICATIONS OF SERVOPACK	1	1.4	10
READJUSTMENT	10	10.3	60
RECEIVING	7	7.1	38
S SERVOMOTOR (Installation)	7	7.2.1	38
SERVOMOTOR (Test run)	9	9.1.1	55
SERVOMOTOR DIMENSIONS	8	8.1	41
SERVOMOTOR FREQUENCY	4	4.4	18
SERVOPACK (Installation)	7	7.2.2	39
SERVOPACK (Test run)	9	9.1.2	55
SERVOPACK (Inspection and maintenance)	11	11.2	64
SERVOPACK (Troubleshooting guide)	12	12.2	66
SERVOPACK Connector (2CN) Terminal Layout and Connection	5	5.5.2	26
SERVOPACK DIMENSIONS	8	8.2	49
Set Voltage and Current Limit Values	6	6.3.2	31
SETTINGS AT THE TIME OF DELIVERY	10	10.1	56
Specifications of Applicable Receptacles	5	5.4.1	23
Specifications of Applicable Receptacles and Cables (Table 5.6)	5	5.5.1	26
Speed and Torque Measurement	6	6.9.2	37
SPEED REFERENCE	6	6.2	30
Speed Reference Circuit	6	6.2.1	30
STARTING AND STOPPING TIME	4	4.2	16
Stop Reference Circuit	6	6.2.2	30
SWITCH SETTING	10	10.5	63
T TEST RUN	9		55
Test Run Operation	9	9.2.2	55
TEST RUN PROCEDURES	9	9.2	55
TROUBLESHOOTING GUIDE	12		65
TYPE DESIGNATION	2		13
Types CACR-SR-□□AC	8	8.2.1	49
Types CACR-SR-□□AE	8	8.2.2	53
U Use of SERVOMOTOR with Magnetic Holding Brake	6	6.9.3	38
V Vibration Class	4	4.6.7	20
Vibration Resistance	4	4.6.6	20
W WIRING	7	7.3	39
Wiring Precautions	7	7.3.2	40

1. RATINGS AND SPECIFICATIONS

1. 1 RATINGS AND SPECIFICATIONS OF R SERIES AC SERVOMOTORS (FOR 200 V)

(1) Ratings

Time Rating: Continuous

Insulation: Class B

Isolation Voltage: 1000 VAC, one minute

Insulation Resistance: 500 VDC, 10M Ω or more

Enclosure: Totally-enclosed, self-cooled

(Equivalent to IP-44 exclusive shaft opening)

Ambient Temperature: 0 to +40°C

Storage Temperature: -20 to +60°C

Ambient Humidity: 20% to 80% (non-condensing)

Vibration: 15 μ m or below

Finish in Munsell Notation: N1.5

Excitation: Permanent magnet

Mounting: Flange mounted

Drive Method: Direct drive

Table 1.1 Ratings and Specifications of R Series AC SERVOMOTORS (For 200 V)

Item	Motor Type USAREM-	Temperature					
		-A5C 2	-01C 2	-02C 2	-03C 2	-05C 2	-07C 2
Rated Output*	W (HP)	50 (0.07)	100 (0.13)	200 (0.27)	300 (0.40)	500 (0.67)	700 (0.93)
Rated Torque*	N·m (oz·in)	0.159 (22.5)	0.318 (45)	0.637 (90)	0.955 (135)	1.59 (225)	2.23 (316)
Continuous Max Torque*	N·m (oz·in)	0.19 (26.9)	0.382 (54.2)	0.765 (108.5)	1.15 (163.1)	1.90 (269.4)	2.67 (378.6)
Peak Torque*	N·m (oz·in)	0.476 (67.5)	0.955 (135)	1.91 (270)	2.86 (405)	4.76 (675)	6.67 (948)
Rated Current*	A	0.71	1.0	2.0	2.7	3.6	5.7
Rated Speed*	r/min	3000					
Max. Speed*	r/min	4500					
Torque Constant	N·m/A (oz·in/A)	0.235 (33.3)	0.353 (50.0)	0.346 (49.0)	0.378 (53.6)	0.466 (66.0)	0.426 (60.4)
Inertia $J_M (=GD^2/4)$	kg·cm ² (oz·in·s ² × 10 ⁻³)	0.076 (1.08)	0.125 (1.78)	0.507 (7.18)	0.766 (10.9)	2.72 (38.6)	3.72 (52.8)
Power Rate*	kW/s	3.30	8.09	8.01	11.9	9.26	13.3
Inertia Time Constant	ms	4.4	3.4	2.9	2.6	2.8	2.5
Inductive Time Constant	ms	1.3	1.6	4.1	4.5	9.4	10.0

* Values when SERVOMOTOR is combined with SERVOPACK and the armature winding temperature is 75°C. Other values are for temperature of 20°C. Shown are normal (TYP) values above.

Notes

1 [] in type designation is determined by output pulses (pulses/rev) of optical encoder as follows

- Standard E (1500 pulses/rev)
- Optional F (1000 pulses/rev)

2 The power supply unit for brake

- Input 100 VAC, Output 90 VDC (DP8401002-1)

For details, see Par. 8.3 on page 54

1. 1 RATINGS AND SPECIFICATIONS OF R SERIES AC SERVOMOTORS (FOR 200 V) (Cont'd)

(2) Torque-speed Characteristics

The values in intermittent duty zone are normal (TYP) values when the power voltage of SERVOPACK is 200 VAC

If 200 VAC or below, the output characteristics may be decreased even if the data is within allowable variation

■ r/min-N·m

Type USAREM-A5C

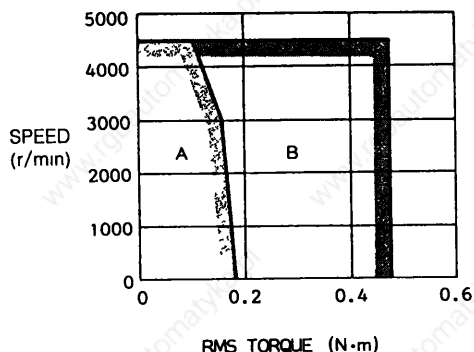

Type USAREM-01C

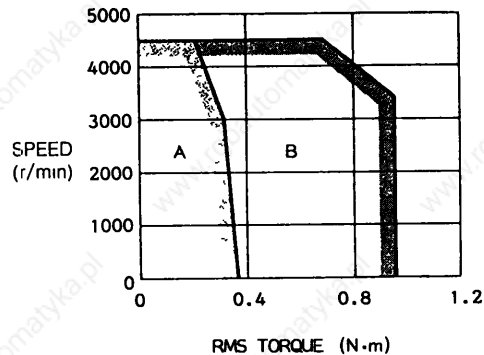

Type USAREM-02C

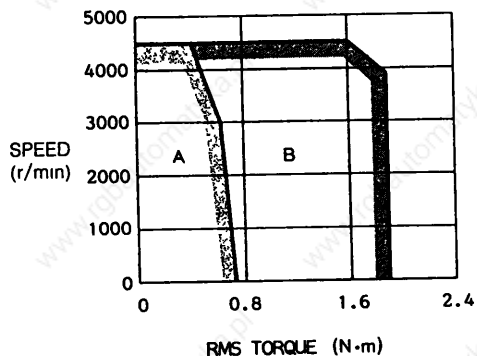

Type USAREM-03C

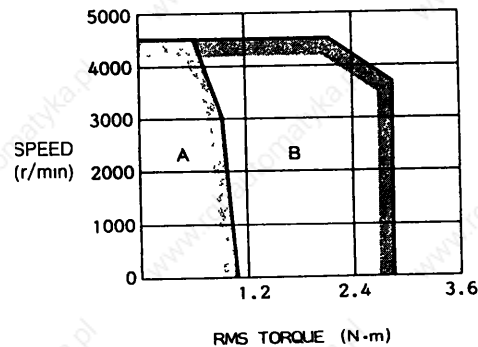

Type USAREM-05C

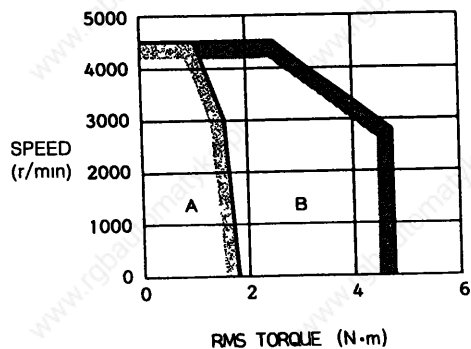

Type USAREM-07C

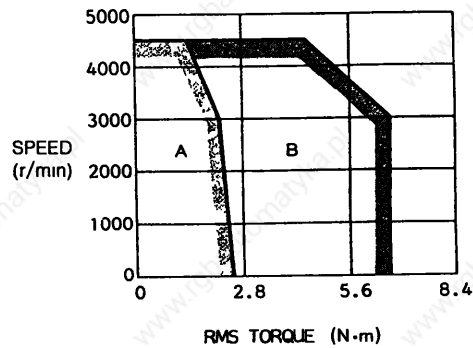

A . Continuous Duty Zone
B . Intermittent Duty Zone

■ r/min-oz·in

Type USAREM-A5C

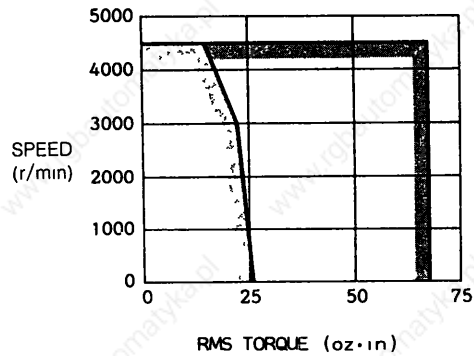

Type USAREM-01C

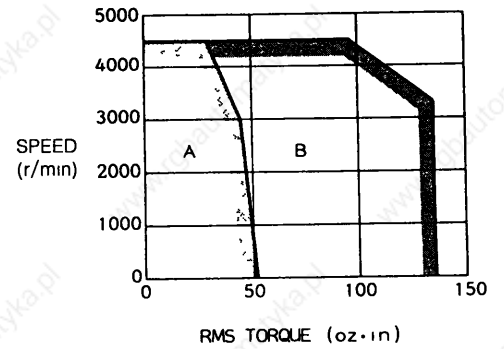

Type USAREM-02C

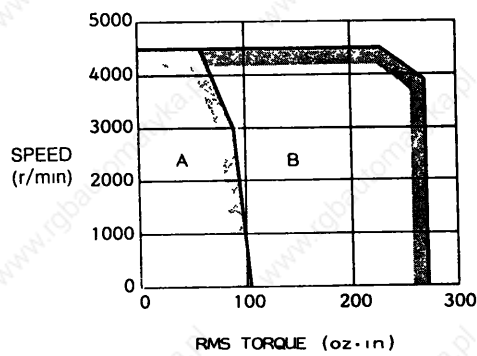

Type USAREM-03C

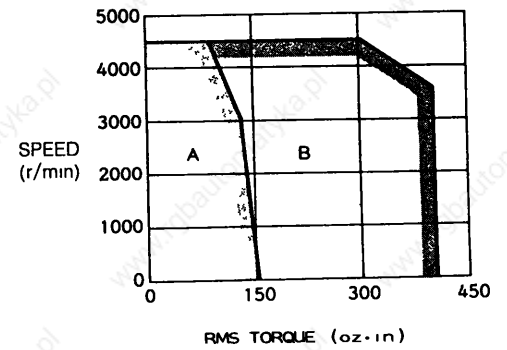

Type USAREM-05C

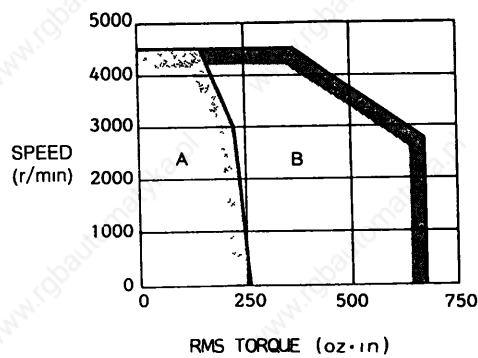

Type USAREM-07C

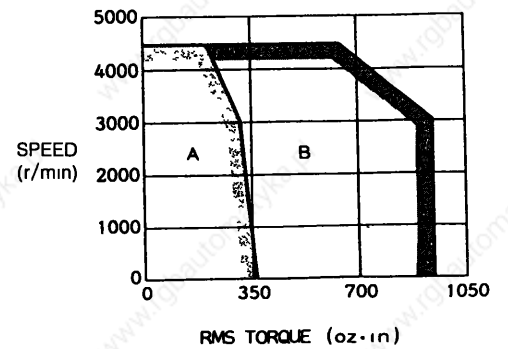

- A** Continuous Duty Zone
- B** Intermittent Duty Zone

1. 2 RATINGS AND SPECIFICATIONS OF R SERIES AC SERVOMOTORS (FOR 100 V)

(1) Ratings

Time Rating continuous

Insulation Class B

Isolation Voltage 1000 VAC, one minute

Insulation Resistance 500 VDC, 10M Ω or more

Enclosure Totally-enclosed, self-cooled

(Equivalent to IP-44 exclusive shaft opening)

Ambient Temperature 0 to +40°C

Storage Temperature -20 to +60°C

Ambient Humidity 20% to 80% (non-condensing)

Vibration 15 μ m or below

Finish in Munsell Notation N1.5

Excitation Permanent magnet

Mounting Flange mounted

Drive Method Direct drive

Table 1.2 Ratings and Specifications of R Series
AC SERVOMOTORS (For 100 V)

Motor Type USAPEM-		-A5D 2	-01D 2	-02D 2	-03D 2	-05D 2
Item						
Rated Output*	W (HP)	50 (0.07)	100 (0.13)	200 (0.27)	300 (0.40)	500 (0.67)
Rated Torque*	N·m (oz·in)	0.159 (22.5)	0.318 (45)	0.637 (90)	0.955 (135)	1.59 (225)
Continuous Max Torque*	N·m (oz·in)	0.19 (26.9)	0.382 (54.2)	0.765 (108.5)	1.15 (163.1)	1.90 (269.4)
Peak Torque*	N·m (oz·in)	0.476 (67.5)	0.955 (135)	1.91 (270)	2.86 (405)	4.76 (675)
Rated Current*	A	1.2	1.7	2.9	3.6	5.5
Rated Speed*	r/min	3000				
Max. Speed*	r/min	4000				
Torque Constant	N·m/A (oz·in/A)	0.136 (19.3)	0.198 (28.1)	0.235 (33.3)	0.284 (40.3)	0.308 (43.6)
Inertia $J_M (=GD^2/4)$	kg·cm ² (oz·in·s ² × 10 ⁻³)	0.076 (1.08)	0.125 (1.78)	0.507 (7.18)	0.766 (10.9)	2.72 (38.6)
Power Rate*	kW/s	3.30	8.09	8.01	11.9	9.26
Inertia Time Constant	ms	4.2	3.2	3.0	2.5	2.7
Inductive Time Constant	ms	1.4	1.7	4.0	4.6	9.6

* Values when SERVOMOTOR is combined with SERVOPACK and the armature winding temperature is 75°C
Other values are for temperature of 20°C. Shown are normal (TYP) values above

Notes

1. In type designation is determined by output pulses (pulses/rev) of optical encoder as follows

- Standard E (1500 pulses/rev)
- Optional F (1000 pulses/rev)

2. The power supply unit for brake

- Input 100 VAC, Output 90 VDC (DP8401002-1)
- For details, see Par. 8.3 on page 54

(2) Torque-speed Characteristics

The values in intermittent duty zone are normal (TYP) values when the power voltage of SERVOPACK is 100 VAC

If 100 VAC or below, the output characteristics may be decreased even if the data is within allowable variation

■ r/min-N·m

Type USAREM-A5D

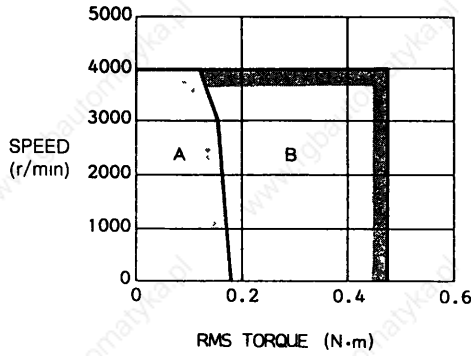

Type USAREM-01D

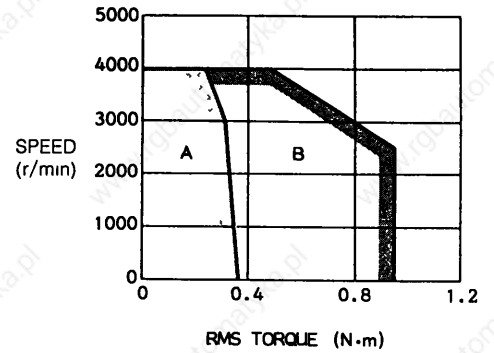

Type USAREM-02D

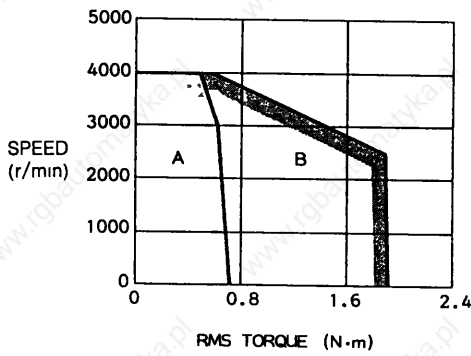

Type USAREM-03D

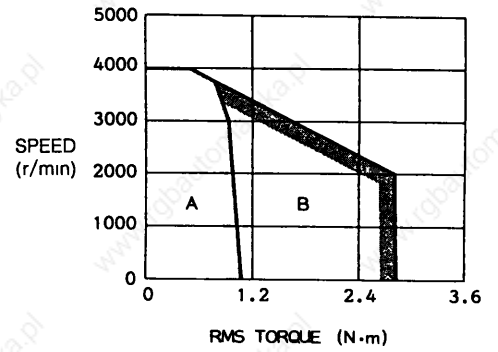

Type USAREM-05D

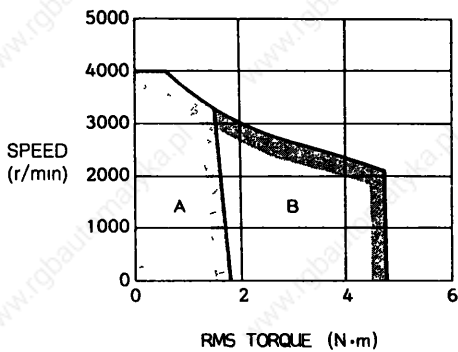

- A · Continuous Duty Zone
- B · Intermittent Duty Zone

1. 2 RATINGS AND SPECIFICATIONS OF R SERIES AC SERVO MOTORS (FOR 100 V) (Cont'd)

■ r/min-oz·in

Type USAREM-A5D

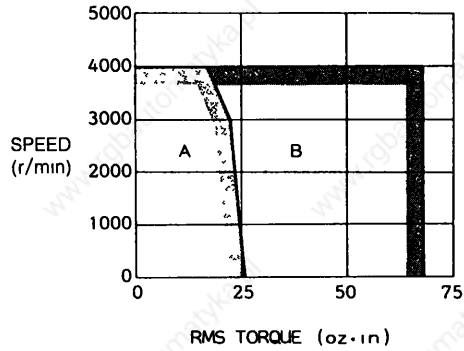

Type USAREM-01D

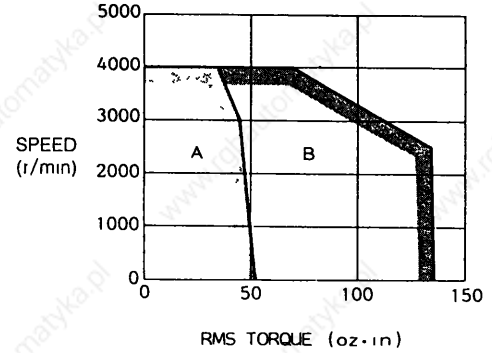

Type USAREM-02D

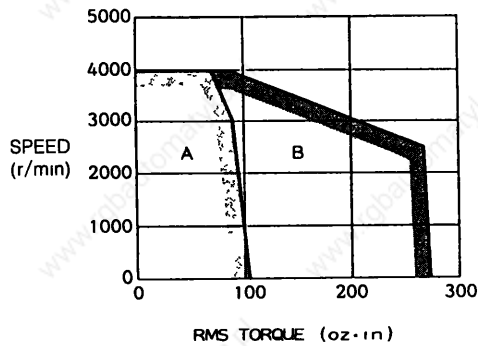

Type USAREM-03D

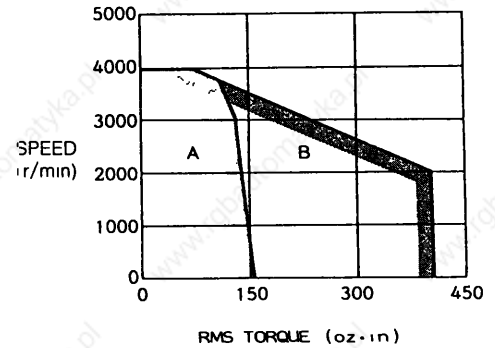

Type USAREM-05D

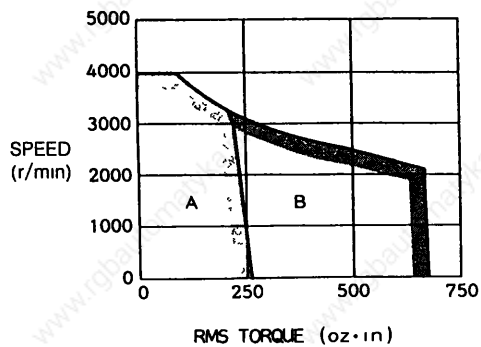

A Continuous Duty Zone
B Intermittent Duty Zone

1. 3 RATINGS AND SPECIFICATIONS OF P SERIES AC SERVOMOTORS (FOR 200 V)

(1) Ratings

Time Rating continuous

Insulation Class B

Isolation Voltage 1000 VAC, one minute

Insulation Resistance 500 VDC, 10MΩ or more

Enclosure Totally-enclosed, self-cooled

(Equivalent to IP-55 exclusive shaft opening)

Ambient Temperature 0 to +40°C

Storage Temperature -20 to +60°C

Ambient Humidity 20% to 80% (non-condensing)

Vibration 15 μm or below

Finish in Munsell Notation N1 5

Excitation Permanent magnet

Mounting Flange mounted

Drive Method Direct drive

Table 1 3 Ratings and Specifications of P Series AC SERVOMOTORS (For 200 V)

Item	Motor Type USAPEM-	01C	02C	03C	05C	07C
		2	2	2	2	2
Rated Output*	W (HP)	100 (0 13)	200 (0 27)	300 (0 40)	500 (0 67)	750 (1 01)
Rated Torque*	N·m (oz·in)	0 318 (44 96)	0 637 (90 33)	0 955 (135 04)	1 59 (224 96)	2 39 (339 04)
Continuous Max Torque*	N·m (oz·in)	0 318 (44 96)	0 637 (90 33)	0 955 (135 04)	1 59 (224 96)	2 39 (339 04)
Peak Torque*	N·m (oz·in)	0 96 (136)	1 91 (269 76)	2 86 (404 96)	4 76 (675 04)	7 06 (1000)
Rated Current*	A	1 0	2 0	2 7	3 6	5 7
Rated Speed*	r/min	3000				
Max Speed*	r/min	4500				
Torque constant	N·m/A (oz·in/A)	0 350 (49 6)	0 337 (47 84)	0 373 (52 8)	0 512 (72 48)	0 442 (62 56)
Inertia J _m (=GD ² /4)	kg·cm ² (oz·in·s ² ×10 ⁻³)	0 392 (5 536)	0 637 (9 024)	0 98 (13 904)	4 78 (67 84)	6 57 (92 96)
Power Rate*	kW/s	2 59	6 37	9 30	5 27	8 71
Inertia Time Constant	ms	5 3	2 8	2 2	4 9	3 3
Inductive Time Constant	ms	4 7	5 8	6 4	10 0	14 0

* Values when SERVOMOTOR is combined with SERVOPACK and the armature winding temperature is 75°C
Other values are for temperature of 20°C Shown are normal (TYP) values above

Notes

1 [] in type designation is determined by output pulses (pulses/rev) of optical encoder as follows

- Standard E (1500 pulses/rev)
- Optional F (1000 pulses/rev)

2 The power supply unit for brake

- Input 100 VAC, Output 90 VDC (DP8401002-2)

For details, see Par 8 3 on page 54

1. 3 RATINGS AND SPECIFICATIONS OF P SERIES AC SERVOMOTORS (FOR 200 V) (Cont'd)

(2) Torque-speed Characteristics

The values in intermittent duty zone are normal (TYP) values when the power voltage of SERVOPACK is 200 VAC

If 200 VAC or below, the output characteristics may be decreased even if the data is within allowable variation

■ r/min-N·m

Type USAPEM-01C

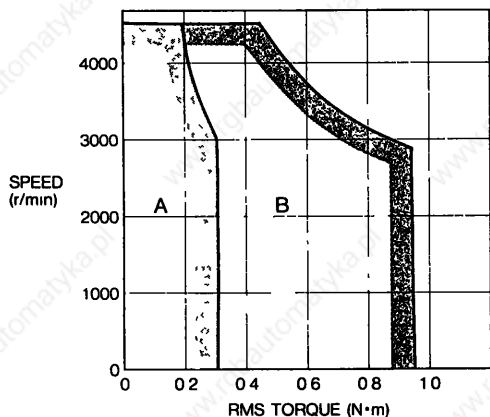

Type USAPEM-02C

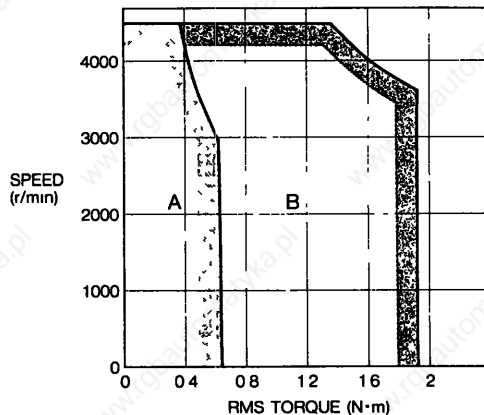

Type USAPEM-03C

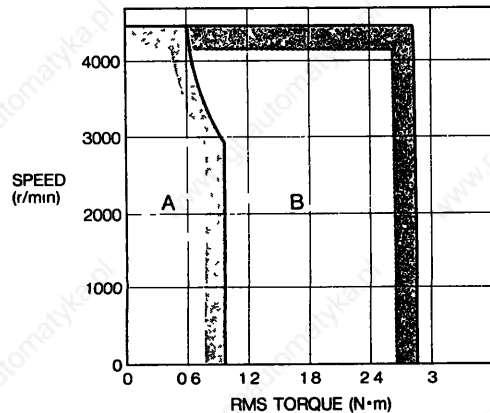

Type USAPEM-05C

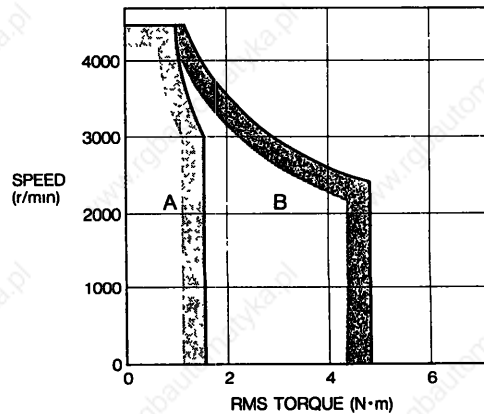

Type USAPEM-07C

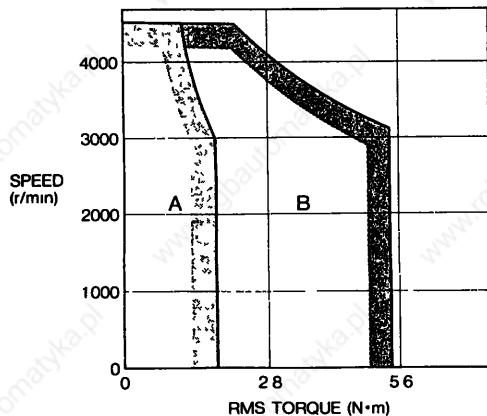

- A** Continuous Duty Zone
- B** Intermittent Duty Zone

■ r/min-oz·in

Type USAPEM-01C

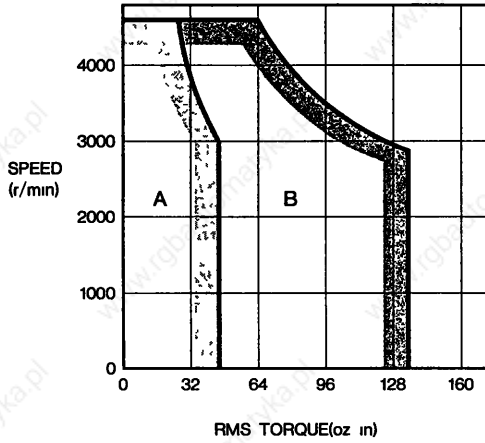

Type USAPEM-02C

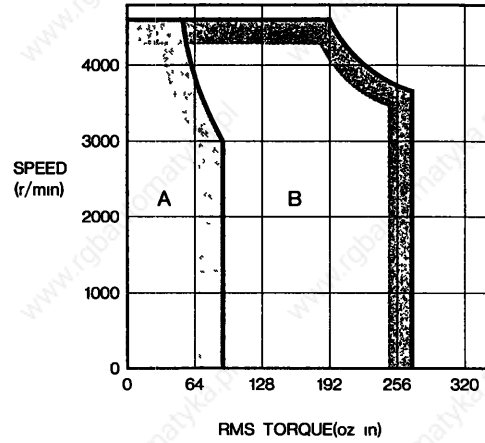

Type USAPEM-03C

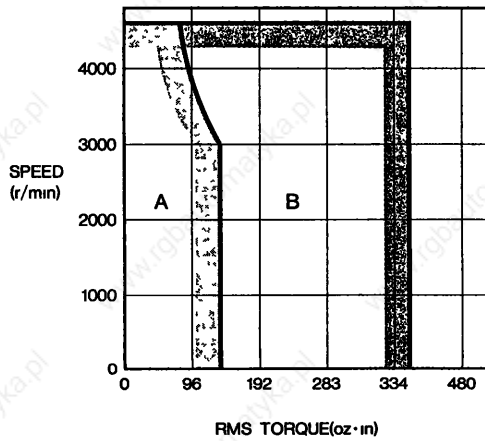

Type USAPEM-05C

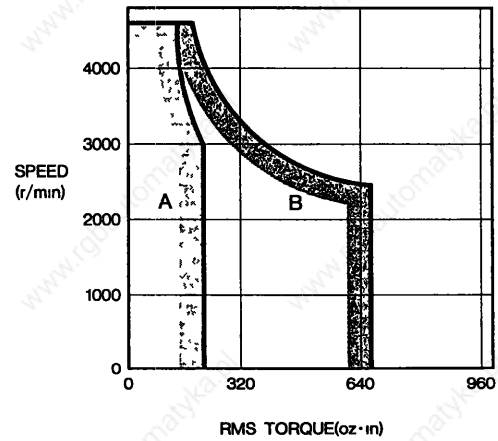

Type USAPEM-07C

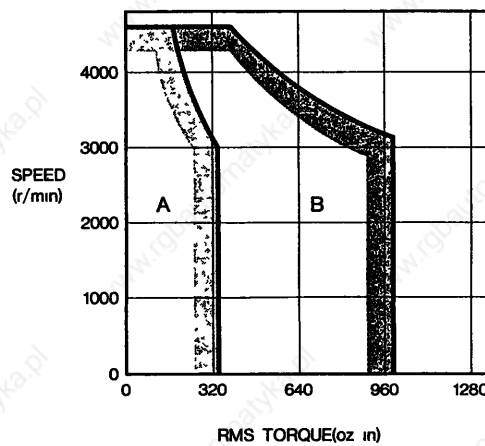

- A** : Continuous Duty Zone
- B** : Intermittent Duty Zone

1. 4 RATINGS AND SPECIFICATIONS OF SERVOPACK

Table 1 4 Ratings and Specifications of SERVOPACK for AS SERVOMOTOR R Series

Voltage Class			200V					
SERVOPACK Type CACR-			SRA5AC1 R	SR01AC1 R	SR02AC1 R	SR03AC1 R	SR05AC1 R	SR07AC1 R
			SRA5AE1 R	SR01AE1 R	SR02AE1 R	SR03AE1 R	—	—
Combined Specifications	Applicable AC SREVO-MOTOR	Type USAREM-	A5C	01C	02C	03C	05C	07C
		Output W (HP)	50 (0 07)	100 (0 13)	200 (0 27)	300 (0 40)	500 (0 67)	700 (0 93)
		Rated/Max. Speed r/min	3000/4500					
		Continuous Output Current A(rms)	0 7	1 0	2 0	2 7	3 6	5 7
		Max Output Current A(rms)	2 1	2 8	5 7	7 8	10 6	16 3
		Allowable Load Inertia J_L (GD ² / ₄) kg·cm ² (oz·in·s ² ×10 ⁻²)	0 76 (10 8)	1 25 (17 8)	5 07 (71 8)	7 66 (109)	27 2 (386)	37 2 (528)
Basic Specifications	Power Supply	Main	1-Phase 200 to 230 VAC +10% 50/60Hz*1					
		Control						
		Control Method	1-Phase full-wave rectifying, transistorized PWM control					
		Feedback	Optical encoder (1500 or 1000 pulses/rev)					
	Environmental Conditions	Ambient Temp	0 to +55°C*2					
		Storage Temp	-20 to +85°C					
		Ambient and Storage Humidity	90% or less (non-condensing)					
		Vibration-/Shock-Resistance	0 5 G/2G					
	Mounting Structure	Rack mounted						
	Approx Mass kg(lb)	SR AC	2 0(4 4)	2 1(4 6)	2 7(6 0)	3 0(6 6)	3 5(7 7)	5 4(11 9)
		SR AE	2 4(5 3)	2 5(5 5)	2 6(5 7)	2 8(6 2)	—	—
Speed Control		Speed Control Range*3	1 1000					
	Speed Regulation*4	Load	0 to 100% ±0 1% or less at 3000r/min ±0 05% or less at 3r/min					
		Voltage	Rating ± 10% ±0 1% or less at 3000r/min ±0 05% or less at 3r/min					
		Temperature	25 ± 25°C ±0 5% or less at 3000r/min ±0 2% or less at 3r/min					
	Frequency Response	100 Hz at $J_L = J_M$						
I/O Signals	Speed Reference	Rated Reference Voltage	± 6 VDC at 3000r/min (forward run at plus reference)					
		Input Impedance	Approx 30kΩ					
		Circuit Time Constant	Approx 35μS					
	Auxiliary Reference*5	Rated Reference Voltage	± 2 to ±10 VDC at 3000r/min (forward run at plus reference)					
		Input Impedance	Approx 5kΩ per V					
		Circuit Time Constant	Approx 22μS					
		Built-in Reference Power Supply	± 12 VDC ±5% ±30mA					
	PG Pulse Output	Types	Aφ, Bφ, Cφ Line driver and open collector					
		Frequency Dividing Ratio	1/1, 1/2, 1/3, 1/4, 1/5, 1/6, 1/10, 1/12, 1/15, 1/20, 1/30, 2/3, 2/5					
	Sequence Input	Servo ON, P drive, F overtravel (P-OT), R overtravel (N-OT), alarm reset						
	Sequence Output	Servo alarm, current limit, TG ON, servo ready, alarm code (3-bit)						
	External Current Limit	20% to max current in each of P and N (3V/100% current)						
Built-in Functions		Dynamic Brake	Operated at main power OFF, servo alarm OFF, etc					
		Regeneration	· 50W/100W type Not provided · 200W to 700W type Provided (containing regenerative resistor)					
		Applicable Load Inertia J_L	Up to 10 times motor inertia*6					
		Overtravel Prevention	DB stop at P-OT, N-OT					
		Protection	Overvoltage(OV), overcurrent(OC), overload(OL), overspeed(OS), MCCB trip(MCCB), PG trouble(PG), voltage drop(UV), CPU error(CPU, A/D), regenerative error (RG)					
		Indication	Power supply (MCCB LED), alarm (7-segment LEDs)					
		Monitor Output	Speed 2V ±5% at 1000r/min, torque 3V ± 10% at 100%					
	Others	Reverse run connection possible (Reverse at plus reference)						

*1 In main circuit power supply, voltage should not exceed 230V + 10 % (253 V) If the voltage should exceed this value, a step down transformer is required

*2 When housed in a panel the inside temperature must not exceed ambient temperature range

*3 In the speed control range the lowest speed is defined under the condition in which there is 100% load regulation, but not stopped

*4 Speed regulation is generally defined as follows

$$\text{Speed regulation} = \frac{\text{No load speed} - \text{Rated speed}}{\text{Rated speed}} \times 100 (\%)$$

Motor speed may be changed by voltage variation or operational amplifier drift due to temperature The ratio of this speed change to the rated speed represents the speed regulation due to voltage or temperature change

*5 Used for application at rated reference voltages other than ±6V

*6 When load J_L exceeds applicable range, see Par 6 7 2, "Load Inertia (J_L)"

Table 1 4 Ratings and Specifications of SERVOPACK for AC SERVOMOTOR R Series (Cont'd)

Voltage Class		100V					
SERVOPACK Type CACR-		SRA5AC2 R	SR01AC2 R	SR02AC2 R	SR03AC2 R	SR05AC2 R	
		SRA5AE2 R	SR01AE2 R	SR02AE2 R	—	—	
Combined Specifications	Applicable AC SREVO-MOTOR	Type USAREM-	A5D	01D	02D	03D	05D
		Output W (HP)	50 (0 07)	100 (0 13)	200 (0 27)	300 (0 40)	500 (0 67)
		Rated/Max Speed r/min	3000/4000				
		Continuous Output Current A(rms)	1 2	1 7	2 9	3 6	5 5
		Max Output Current A(rms)	3 6	5 0	8 5	10 6	16 3
		Allowable Load Inertia J _L (GD ² / ₄) (oz·in·s ² × 10 ⁻²)	0 76 (10 8)	1 25 (17 8)	5 07 (71 8)	7 66 (109)	27 2 (386)
Basic Specifications	Power Supply	Main	1-Phase 200 to 230 VAC +10% 50/60Hz*1				
		Control					
		Control Method	1-Phase full-wave rectifying, transistorized PWM control				
		Feedback	Optical encoder (1500 or 1000 pulses/rev)				
	Environmental Conditions	Ambient Temp	0 to +55°C*2				
		Storage Temp	-20 to +85°C				
		Ambient and Storage Humidity	90% or less (non-condensing)				
		Vibration-/Shock-Resistance	0 5G/2G				
	Mounting Structure	Rack mounted					
	Approx Mass kg(lb)	SR AC	2 1(4 6)	2 7(6 0)	3 0(6 6)	3 5(7 7)	5 4(11 9)
		SR AE	2 5(5 5)	2 6(5 7)	2 8(6 2)	—	—
Speed Control	Speed Control Range*3		1 1000				
	Speed Regulation*4	Load	0 to 100% 0 1% or less at 3000r/min ±0 05% or less at 3r/min				
		Voltage	Rating ± 10% ±0 1% or less at 3000r/min ±0 05% or less at 3r/min				
		Temperature	25 ± 25°C ±0 5% or less at 3000r/min ±0 2% or less at 3r/min				
	Frequency Response	100 Hz at J _L = J _M					
I/O Signals	Speed Reference	Rated Reference Voltage	± 6 VDC at 3000r/min (forward run at plus reference)				
		Input Impedance	Approx 30kΩ				
		Circuit Time Constant	Approx 35μS				
	Auxiliary Reference*5	Rated Reference Voltage	± 2 to ±10 VDC at 3000r/min (forward run at plus reference)				
		Input Impedance	Approx 5kΩ per V				
		Circuit Time Constant	Approx 22μS				
		Built-in Reference Power Supply	± 12 VDC ±5% ±30mA				
	PG Pulse Output	Types	Aφ, Bφ, Cφ Line driver and open collector				
		Frequency Dividing Ratio	1/1, 1/2, 1/3, 1/4, 1/5, 1/6, 1/10, 1/12, 1/15, 1/20, 1/30, 2/3, 2/5				
	Sequence Input	Servo ON, P drive, F overtravel (P-OT), R overtravel (N-OT), alarm reset					
	Sequence Output	Servo alarm, current limit, TG ON, servo ready, alarm code (3-bit)					
	External Current Limit	20% to max current in each of P and N (3V/100% current)					
Built-in Functions	Dynamic Brake		Operated at main power OFF, servo alarm, overtravel, etc				
	Regeneration		· 50W type Not provided · 100W to 500W type Provided (containing regenerative resistor)				
	Applicable Load Inertia J _L		Up to 10 times motor inertia*6				
	Overtravel Prevention		DB stop at P-OT, N-OT				
	Protection		Overvoltage(OV), overcurrent(OC), overload(OL), overspeed(OS), MCCB trip(MCCB), PG trouble(PG), voltage drop(UV), CPU error(CPU, A/D), regenerative error (RG)				
	Indication		Power supply (MCCB LED), alarm (7-segment LEDs)				
	Monitor Output		Speed 2V ±5% at 1000r/min, torque 3V ± 10% at 100%				
	Others		Reverse run connection possible (Reverse at plus reference)				

*1 In main circuit power supply, voltage should not exceed 230V + 10% (253 V) If the voltage should exceed this value, a step down transformer is required

*2 When housed in a panel the inside temperature must not exceed ambient temperature range

*3 In the speed control range the lowest speed is defined under the condition in which there is 100% load regulation, but not stopped

*4 Speed regulation is generally defined as follows

$$\text{Speed regulation} = \frac{\text{No load speed} - \text{Rated speed}}{\text{Rated speed}} \times 100 (\%)$$

Motor speed may be changed by voltage variation or operational amplifier drift due to temperature The ratio of this speed change to the rated speed represents the speed regulation due to voltage or temperature change

*5 Used for application at rated references voltages other than ±6V

*6 When load J_L exceeds applicable range, see Par 6 7 2, "Load Inertia (J_L)"

Table 1 5 Ratings and Specifications of SERVOPACK for AC SERVOMOTOR P Series

Voltage Class			200V					
SERVOPACK Type CACR-			SR01AC1 P	SR02AC1 P	SR03AC1 P	SR05AC1 P	SR07AC1 P	
			SR01AE1 P	SR02AE1 P	SR03AE1 P	—	—	
Combined Specifications	Applicable AC SREVO-MOTOR	Type USAPEM-	01C	02C	03C	05C	07C	
		Output	100 (0 13)	200 (0 27)	300 (0 40)	500 (0 67)	750 (1 01)	
		Rated/Max Speed	3000/4500					
	Continuous Output Current	A(rms)	1 0	2 0	2 7	3 6	5 7	
	Max Output Current	A(rms)	2 8	5 7	7 8	10 6	16 3	
	Allowable Load Inertia J_L (GD ² /4)	kg·cm ² (oz·in·s ² ×10 ⁻²)	1 95 (27 84)	3 2 (45 28)	4 9 (69 6)	23 9 (339 2)	32 85 (465 6)	
Basic Specifications	Power Supply	Main	1-Phase 200 to 230 VAC +10% -15%, 50/60Hz*1					
		Control						
	Control Method		1-Phase full-wave rectifying, transistorized PWM control					
	Feedback		Optical encoder (1500 or 1000 pulses/rev)					
	Environmental Conditions	Ambient Temp		0 to +55°C*2				
		Storage Temp		-20 to +85°C				
		Ambient and Storage Humidity		90% or less (non-condensing)				
		Vibration-/Shock-Resistance		0 5G/2G				
	Mounting Structure		Rack mounted					
	Approx Mass	kg(lb)	SR AC	2 1(4 6)	2 7(6 0)	3 0(6 6)	3 5(7 7)	5 4(11 9)
SR AE			2 5(5 5)	2 6(5 7)	2 8(6 2)	—	—	
Speed Control	Speed Control Range*3		1 1000					
	Speed Regulation*4	Load	0 to 100% 0 1% or less at 3000r/min ±0 05% or less at 3r/min					
		Voltage	Rating ± 10% ±0 1% or less at 3000r/min ±0 05% or less at 3r/min					
		Temperature	25 ± 25°C ±0 5% or less at 3000r/min ±0 2% or less at 3r/min					
Frequency Response		100 Hz at $J_L = J_M$						
I/O Signals	Speed Reference	Rated Reference Voltage	± 6 VDC at 3000r/min (forward run at plus reference)					
		Input Impedance	Approx 30kΩ					
		Circuit Time Constant	Approx 35μS					
	Auxiliary Reference*5	Rated Reference Voltage	± 2 to ±10 VDC at 3000r/min (forward run at plus reference)					
		Input Impedance	Approx 5kΩ per V					
		Circuit Time Constant	Approx 22μS					
	Built-in Reference Power Supply		± 12 VDC ±5%, ±30mA					
	PG Pulse Output	Types	Aφ, Bφ, Cφ Line driver and open collector					
	Output	Frequency Dividing Ratio	1/1, 1/2, 1/3, 1/4, 1/5, 1/6, 1/10, 1/12, 1/15, 1/20, 1/30, 2/3, 2/5					
	Sequence Input		Servo ON, P drive, F overtravel (P-OT), R overtravel (N-OT), alarm reset					
Sequence Output		Servo alarm, current limit, TG ON, servo ready, alarm code (3-bit)						
External Current Limit		20% to max current in each of P and N (3V/100% current)						
Built-in Functions	Dynamic Brake		Operated at main power OFF, servo alarm, servo OFF, etc					
	Regeneration		Provided (containing regenerative resistor)					
	Applicable Load Inertia J_L		Up to 10 times motor inertia*6					
	Overtravel Prevention		DB stop at P-OT N-OT					
	Protection		Overvoltage(OV), overcurrent(OC), overload(OL), overspeed(OS), MCCB trip(MCCB),PG trouble(PG), voltage drop(UV), CPU error(CPU, A/D), regenerative error (RG)					
	Indication		Power supply (MCCB LED), alarm (7-segment LEDs)					
	Monitor Output		Speed 2V ±5% at 1000r/min, torque 3V ± 5% at 100%					
Others		Reverse run connection possible (Reverse at plus reference)						

*1 In main circuit power supply, voltage should not exceed 230V + 10 % (253 V) If the voltage should exceed this value, a step down transformer is required

*2 When housed in a panel the inside temperature must not exceed ambient temperature range

*3 In the speed control range the lowest speed is defined under the condition in which there is 100% load regulation, but not stopped

*4 Speed regulation is generally defined as follows

$$\text{Speed regulation} = \frac{\text{No load speed} - \text{Rated speed}}{\text{Rated speed}} \times 100 (\%)$$

Motor speed may be changed by voltage variation or operational amplifier drift due to temperature The ratio of this speed change to the rated speed represents the speed regulation due to voltage or temperature change

*5 Used for application at rated reference voltages other than ±6V

*6 When load J_L exceeds applicable range, see Par 6 7 2, "Load Inertia (J_L)"

2. TYPE DESIGNATION

• AC SERVOMOTOR

USAREM - 05CE2

AC SERVOMOTOR

SERIES

- AR R Series
- AP P Series

ENCLOSURE

- E: Totally-enclosed Self-cooled Type

MAGNET TYPE

M: Rare Earth

MOTOR OUTPUT

- A5 50 W, 0.07HP • 03 300 W, 0.40HP
- 01 100 W, 0.13HP • 05 500 W, 0.67HP
- 02 200 W, 0.27HP • 07 700 W, 0.94HP
- 750 W, 1.01HP

DESIGN REVISION ORDER

- C: 200 V Class
- D: 100 V Class

DETECTOR (Table 2.3)

- E: 1500 pulses/rev (Standard)
- F: 1000 pulses/rev

SHAFT TYPE

- 1 Tapered
- 2 Straight (Standard)

DRIVE END SPECIFICATION

- O or Blank Without Key* • S With Shaft Seal
- K With Key (Standard) • T With Key & Shaft Seal

OPPOSITE DRIVE END SPECIFICATION

Blank: Standard

- B: With Brake

*Blank When the opposite drive end is standard (without brake) type

(example) Type USAREM-05CE2

O When the opposite drive end is "with brake" type

(example) Type USAREM-05CE2OB

• SERVOPACK

CACR - SR05AC1ER

AC SERVOPACK

SERIES CONTROL TYPE

- SR: Speed

MOTOR OUTPUT

- A5: 50 W, 0.07HP • 03: 300 W, 0.40HP
- 01: 100 W, 0.13HP • 05: 500 W, 0.67HP
- 02: 200 W, 0.27HP • 07: 700 W, 0.94HP

APPLICATION

- A R Series
- P Series

DESIGN REVISION ORDER

C, D, E

INPUT FORM

- 1: 200 V, Analog
- 2: 100 V, Analog

DETECTOR

- E: 1500 pulses/rev
- F: 1000 pulses/rev



APPLICABLE MOTOR SERIES

- R R Series
- P P Series

3. LIST OF STANDARD COMBINATION

(I) R Series SERVOMOTOR and SERVOPACK

Table 3 1 List of Standard Combination (R series)

Class	SERVOPACK Type CACR-		AC SERVOMOTOR		Power Capacity per SERVOPACK kVA	Current Capacity per MCCB or Fuse† A	Applicable Noise Filter	Recommended Noise Filter†		Power ON/OFF Switch	
			Type USAREM-	Optical Encoder pulses/rev				Type	Specification		
200V	50W (0.07HP)	SRASAC1ER	A5CE2	1500	0.3	5	Good 	LF-205A	Single-phase, 200 VAC class	YASKAWA type HI-16Es rated 35A or equivalent	
		SRASAC1FR	A5CF2	1000							
	100W (0.13HP)	SR01AC1ER	01CE2	1500	0.5						
		SR01AC1FR	01CF2	1000							
	200W (0.27HP)	SR02AC1ER	02CE2	1500	0.75						
		SR02AC1FR	02CF2	1000							
	300W (0.40HP)	SR03AC1ER	03CE2	1500	1.0						7
		SR03AC1FR	03CF2	1000							
	500W (0.67HP)	SR05AC1ER	05CE2	1500	1.4						11
		SR05AC1FR	05CF2	1000							
700W (0.93HP)	SR07AC1ER	07CE2	1500	2.0	15						
	SR07AC1FR	07CF2	1000								
100V	50W (0.07HP)	SRASAC2ER	A5DE2	1500	0.3	8	Poor 	LF-205A	Single-phase, 200 VAC class	YASKAWA type HI-16Es rated 35A or equivalent	
		SRASAC2FR	A5DF2	1000							
	100W (0.13HP)	SR01AC2ER	01DE2	1500	0.5						
		SR01AC2FR	01DF2	1000							
	200W (0.27HP)	SR02AC2ER	02DE2	1500	0.75						
		SR02AC2FR	02DF2	1000							
	300W (0.40HP)	SR03AC2ER	03DE2	1500	1.0						11
		SR03AC2FR	03DF2	1000							
	500W (0.67HP)	SR05AC2ER	05DE2	1500	1.4						15
		SR05AC2FR	05DF2	1000							

* Values at rated load

† Operating characteristic (25°C) 200 % 2s or more 700 % 0.01s or more

† Made by Tokin Corp





Table 3 2 Characteristics of AC SERVOMOTOR, Detector and Holding Brake for Standard Combination (R series)

Class	SERVOPACK Type CACR-	AC SERVOMOTOR Type USAREM-	AC SERVOMOTOR			Detector			Holding Brake		
			Receptacle Type	L-type Plug	Cable Clamp	Receptacle Type	L-type Plug	Cable Clamp	Receptacle Type	L-type Plug	Cable Clamp
200V	SRASAC1ER	A5CE2KB	MS3101A 14S-2P	MS3106B* 14S-2S	MS3057 -6A	MS3101A 20-29P	MS3106B 20-29S*	MS3057 -12A	MS3101A 14S-6P	MS3106B 14-6S*	MS3057 -6A
	SRASAC1FR	A5CF2KB						MS3057A -12A			
	SR01AC1ER	01CE2KB									
	SR01AC1FR	01CF2KB									
	SR02AC1ER	02CE2KB	MS3102A 18-10P	MS3108B 18-10S	MS3057 -10A	MS3102A 20-29P	MS3108B 20-29S	MS3057 -12A	MS3102A 18-12P	MS3108B 18-12S	MS3057 -10A
	SR02AC1FR	02CF2KB									
	SR03AC1ER	03CE2KB									
	SR03AC1FR	03CF2KB									
	SR05AC1ER	05CE2KB	MS3102A 20-4P	MS3108B 20-4S	MS3057 -12A	MS3102A 20-29P	MS3108B 20-29S	MS3057 -12A	MS3102A 20-17P	MS3108B 20-17S	MS3057 -12A
	SR05AC1FR	05CF2KB									
SR07AC1ER	07CE2KB										
SR07AC1FR	07CF2KB										
100V	SRASAC2ER	A5DE2KB	MS3102A 14S-2P	MS3106B 14S-2S*	MS3057 -6A	MS3101A 20-29P	MS3106B 20-29S*	MS3057 -12A	MS3101A 14S-6P	MS3106B 14S-6S*	MS3057 -6A
	SRASAC2FR	A5DF2KB									
	SR01AC2ER	01DE2KB									
	SR01AC2FR	01DF2KB									
	SR02AC2ER	02DE2KB	MS3102A 18-10P	MS3108B 18-10S	MS3057 -10A	MS3102A 20-29P	MS3108B 20-29S	MS3057 -12A	MS3102A 18-12P	MS3108B 18-12S	MS3057 -10A
	SR02AC2FR	02DF2KB									
	SR03AC2ER	03DE2KB									
	SR03AC2FR	03DF2KB									
	SR05AC2ER	05DE2KB	MS3102A 20-4P	MS3108B 20-4S	MS3057 -12A	MS3102A 20-29P	MS3108B 20-29S	MS3057 -12A	MS3102A 20-17P	MS3108B 20-17S	MS3057 -12A
	SR05AC2FR	05DF2KB									

*Straight plug

(2) P Series SERVOMOTOR and SERVOPACK

Table 3 3 List of Standard Combination (P Series)

class	SERVOPACK Type CACR-		AC SERVOMOTOR		Power Capacity per SERVOPACK † kVA	Current Capacity per MCCB or Fuse † A	Applicable Noise Filter	Recommended Noise Filter ‡		Power ON/OFF Switch
			Type USAPEM-	Optical Encoder pulses/rev				Type	Specfication	
200 V	100 W (0.13HP)	SR 01 AC1EP	A1 CE 2	1500	0.5	5	Good 	LF-205 A	Single-phase, 200 VAC class	5 A
		SR 01 AE1EP		1000						
		SR 01 AC1FP	A1 CF 2	1500						
		SR 01 AE1FP		1000						
	200 W (0.27HP)	SR 02 AC1EP	02 CE 2	1500	0.75	5	Poor 	LF-210	10 A	
		SR 02 AE1EP		1500						
		SR 02 AC1FP	02 CF 2	1000						
	SR 02 AE1FP	1000								
	300 W (0.40HP)	SR 03 AC1EP	03 CE 2	1500	1.0	7	Poor 	LF-215	15 A	
		SR 03 AE1EP		1500						
		SR 03 AC1FP	03 CF 2	1000						
	SR 03 AE1FP	1000								
	500 W (0.67HP)	SR 05 AC1EP	05 CE 2	1500	1.4	11	Poor 	LF-220	20 A	
		SR 05 AC1FP	05 CF 2	1000						
700 W (0.93HP)	SR 07 AC1EP	07 CE 2	1500	2.0	15	Poor 	LF-220	20 A		
	SR 07 AC1FP	07 CF 2	1000							

* Values at rated load

† Operating characteristics (25°C) 200% 2s or more, 700% 0.01s or more

‡ Made by Tokin Corp

Table 3 4 Characteristics of AC SERVOMOTOR, Detector and Holding Brake for Standard Combination (P Series)

class	SERVOPACK Type CACR-		AC SERVOMOTOR		AC SERVOMOTOR	Detector		Holding Brake
			Type USAPEM-	Optical Encoder pulses/rev	Pin Terminal	Connector (Maintain LOCK Universal)		Pin Terminal
						Plug	Pin	
200 V	100 W (0.13HP)	SR 01 AC1EP	01 CE 2 KB	1500	PC 2005-M	172171-1	170363-1	PC 2005-M
		SR 01 AE1EP		1000				
		SR 01 AC1FP	01 CF 2 KB	1500				
		SR 01 AE1FP		1000				
	200 W (0.27HP)	SR 02 AC1EP	02 CE 2 KB	1500	PC 2005-M	172171-1	170363-1	PC 2005-M
		SR 02 AE1EP		1500				
		SR 02 AC1FP	02 CF 2 KB	1000				
	SR 02 AE1FP	1000						
	300 W (0.40HP)	SR 03 AC1EP	03 CE 2 KB	1500	PC 2005-M	172171-1	170363-1	PC 2005-M
		SR 03 AE1EP		1500				
		SR 03 AC1FP	03 CF 2 KB	1000				
	SR 03 AE1FP	1000						
	500 W (0.67HP)	SR 05 AC1EP	05 CE 2 KB	1500	PC 2005-M	172171-1	170363-1	PC 2005-M
		SR 05 AC1FP	05 CF 2 KB	1000				
700 W (0.93HP)	SR 07 AC1EP	07 CE 2 KB	1500	PC 2005-M	172171-1	170363-1	PC 2005-M	
	SR 07 AC1FP	07 CF 2 KB	1000					

Notes Mating pin terminal on motor side (common to with/without brake) PC 2005-F

Mating cap on detector side 172163-1 (Made by Amp)

Mating socket on detector side 170365-1 (Made by Amp)

4. CHARACTERISTICS

4. 1 OVERLOAD CHARACTERISTICS

The overload protective circuit built in SERVOPACK prevents the motor and SERVOPACK from overloading and restricts the allowable conduction time of SERVOPACK (See Fig 4 1)

If the allowable power-on time during motor locking is maximum, the higher the motor speed is, the quicker the motor response to the same overload

The overload detection level is set precisely by the hot start conditions at an ambient temperature of 55°C and cannot be changed.

NOTE

Hot start is the overload characteristics when the SERVOPACK is running at the rated load and thermally saturated

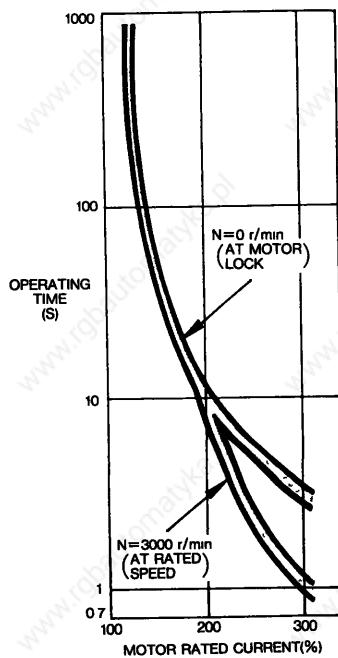

Fig 4 1 Allowable Conduction Current of SERVOPACK

4. 2 STARTING AND STOPPING TIME

The starting time and stopping time of SERVOMOTOR under a constant load is shown by the formula below Viscous or friction torque of the motor is disregarded

Starting Time

$$tr = 1047 \times \frac{N_R (J_M + J_L)}{Kt I_R (\alpha - \beta)} \text{ (ms)}$$

Stopping Time.

$$tr = 1047 \times \frac{N_R (J_M + J_L)}{Kt I_R (\alpha + \beta)} \text{ (ms)}$$

Where,

N_R Rated motor speed (r/min)

J_M Motor moment of inertia J ($\text{kg} \cdot \text{cm}^2, \text{oz} \cdot \text{in} \cdot \text{s}^2$)

$J_D^2 L$ Load moment of inertia J ($\text{kg} \cdot \text{cm}^2, \text{oz} \cdot \text{in} \cdot \text{s}^2$)

Kt Torque constant of motor ($\text{N} \cdot \text{m}/\text{A} = \text{oz} \cdot \text{in}/\text{A}$)

I_R Motor rated current (A)

$\alpha = I_P / I_R$ Accel/decel current constant

I_P Accel/decel current (Accel/decel current α times the motor rated current) (A)

$\beta = I_L / I_R$ Load current constant

I_L Current equivalent to load torque (Load current β times the motor rated current) (A)

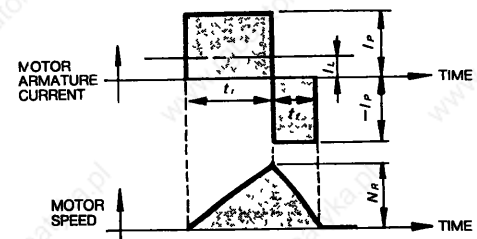

Fig. 4. 2 Timing Chart of Motor Armature Current and Speed

4. 3 ALLOWABLE FREQUENCY OF OPERATION

The allowable frequency of operation is restricted by the SERVOMOTOR and SERVOPACK, and both the conditions must be considered for satisfactory operation

- Allowable frequency of operation restricted by the SERVOPACK

The allowable frequency of operation is restricted by the heat generated in the regenerative resistor in the SERVOPACK, and varies depending on the motor types, capacity, load $J(J_L)$, acceleration/deceleration current values, and motor speed. If the frequency of operation exceeds 60 times/min when load $J=0$ before the motor becomes rated speed, or if it exceeds $\frac{60}{m+1}$ cycles/min when load $J = \text{motor } J(J_M) \times m$, contact your YASKAWA representative.

- Allowable frequency of operation restricted by the SERVOMOTOR

The allowable frequency of operation varies depending on the load conditions, motor running time and the operating conditions. Typical examples are shown below. See Par 4.2, "Starting and Stopping Time" for symbols.

- When the motor repeats rated-speed operation and being at standstill (Fig 4.3)

Cycle time(T) should be determined so that RMS value of motor armature current is lower than the motor rated current

$$T \geq \frac{I_p^2(tr + tf) + I_L^2ts}{I_R^2} (s)$$

Where cycle time(T) is determined, values I_p , tr , tf satisfying the formula above, should be specified.

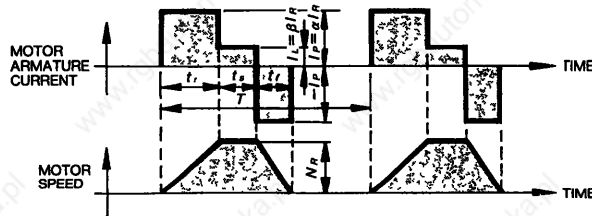

Fig. 4. 3 Timing Chart of Motor Armature Current and Speed

- When the motor remains at standstill between cycles of acceleration and deceleration without continuous rated speed running (Fig.4 4)

The timing chart of the motor armature current and speed is as shown in Fig.4 4. The allowable frequency of operation "n" can be calculated as follows

$$n = 286.5 \times \frac{Kt \cdot I_R}{N_R(J_M + J_L)} \left(\frac{1}{a} - \frac{\beta^2}{a^2} \right) \text{ (times/min)}$$

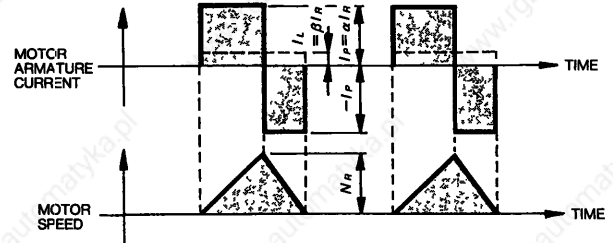

Fig 4 4 Timing Chart of Motor Armature Current and Speed

- When the motor accelerates, runs at constant speed, and decelerates in a continuing cycle without being at standstill (Fig 4 5)

The timing chart of the motor armature current and speed is as shown in Fig 4 5

The allowable frequency of operation "n" can be calculated as follows

$$n = 286.5 \times \frac{Kt \cdot I_R}{N_R(J_M + J_L)} \left(\frac{1}{a} - \frac{\beta^2}{a^2} \right) \text{ (times/min)}$$

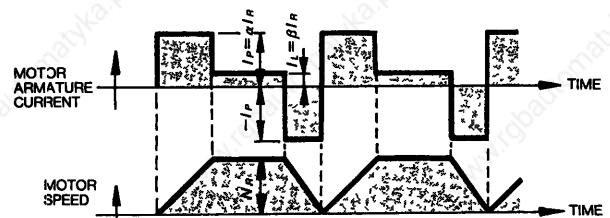

Fig 4. 5 Timing Chart of Motor Armature Current and Speed

4. 4 SERVOMOTOR FREQUENCY

In the servo drive consisting of SERVOPACK and SERVOMOTOR, motor speed amplitude is restricted by the maximum armature current controlled by SERVOPACK

The relation between motor speed amplitude (N) and frequency(f) is shown by the formula below

$$N = 152 \times \frac{\alpha \times K_t \times I_R}{(J_M + J_L) f} \text{ (r/min)}$$

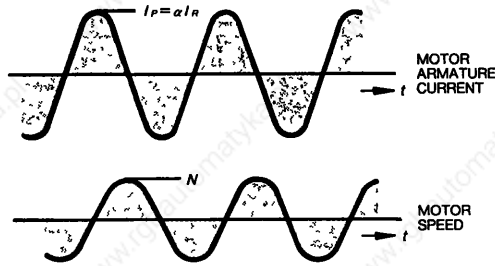

Fig 4 6 Timing Chart of Motor Armature Current and Speed

4. 5 MOTOR SPEED-REFERENCE INPUT CHARACTERISTICS

Fig.47 shows motor speed and input voltage curve when speed reference input terminals 1CN-② and ③ are used. With auxiliary input terminals, 1CN-④ and ⑤, motor speed can be set to the rating by adjusting **IN-B** potentiometer as long as input voltage is within ± 2 V to ± 10 V. See Fig 4 8

The forward motor rotation(+) means counterclockwise (CCW) rotation when viewed from the drive end

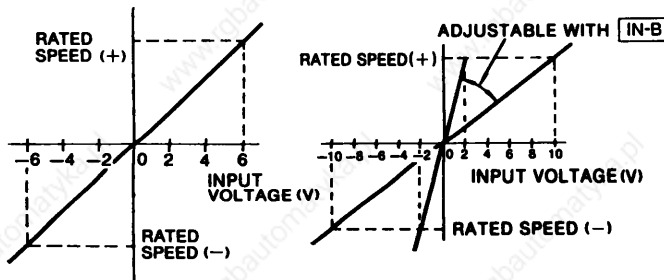

Fig 4 7 Speed-Input Voltage Characteristics

Fig. 4. 8 Speed-Input Voltage Characteristics when Auxiliary Input Terminals 1CN-④ and ⑤ are used.

4. 6 MOTOR MECHANICAL CHARACTERISTICS

4 6 1 Mechanical Strength

AC SERVOMOTORS can carry up to 300% of the rated momentary maximum torque at output shaft

4. 6 2 Allowable Radial Load and Thrust Load

Table 4 1 shows allowable loads according to AC SERVOMOTOR types

Table 4 1 R Series Allowable Radial Load and Thrust Load

Motor Type USAREM-	Allowable Radial Load* N (lb)	Allowable Thrust Load N (lb)
A5 2K	78 45 (18)	39 23 (9)
01 2K		
02 2K	245 17 (55)	98 07 (22)
03 2K		
05 2K	392 27 (88)	147 1 (33)
07 2K		

* Maximum values of the load applied to the shaft extension

Table 4. 2 P Series Allowable Radial Load and Thrust Load

Motor Type USAPEM-	Allowable Radial Load* N (lb)	Allowable Thrust Load N (lb)
01 2K	88 2 (20)	39 2 (9)
02 2K	147 (33)	58 8 (13)
03 2K	196 (44)	58 8 (13)
05 2K	343 (77)	98 (22)
07 2K	441 (99)	127 4 (29)

* Maximum values of the load applied to the shaft extension

4 6 3 Mechanical Specifications

Table 4. 3 Mechanical Specifications in mm

Accuracy (T I R)†	Reference Diagram
Flange surface perpendicular to shaft ①	
Flange diameter concentric to shaft ②	
Shaft run out ③	

†T I R (Total Indicator Reading)

4 6 4 Direction of Rotation

AC SERVOMOTORS rotate counterclockwise (CCW) when viewed from the drive end when motor and detector leads are connected as shown below

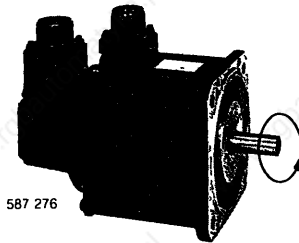
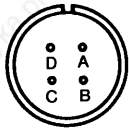

Fig 4 9 AC SERVOMOTOR

(I) R Series Connector Specifications

(a) Motor receptacle

• Standard



A	Phase U
B	Phase V
C	Phase W
D	Frame Ground

• With brake

(50W, 0.07HP)
(100W, 0.13HP)



A	Phase U
B	Phase V
C	Phase W
D	Brake terminal
E	Frame Ground

(200W, 0.27HP)
(300W, 0.40HP)

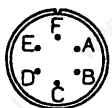

(500W, 0.67HP)
(700W, 0.93HP)

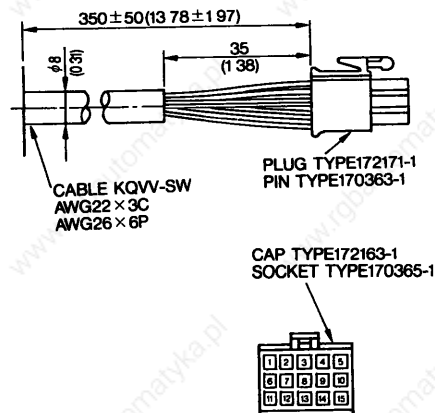
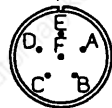

(b) Detector receptacle

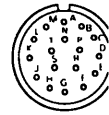

A	Channel A output	K	Channel U output
B	Channel \bar{A} output	L	Channel \bar{U} output
C	Channel B output	M	Channel V output
D	Channel \bar{B} output	N	Channel \bar{V} output
E	Channel Z output	P	Channel W output
F	Channel \bar{Z} output	R	Channel \bar{W} output
G	0V	S	—
H	+5VDC	T	—
J	Frame ground	—	—

(2) P Series Connector Specifications

(a) Motor side

• Without brake

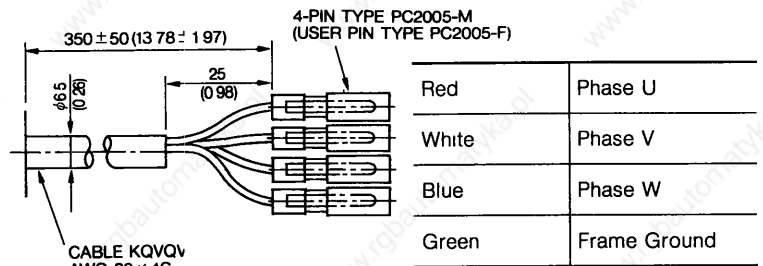

• With brake

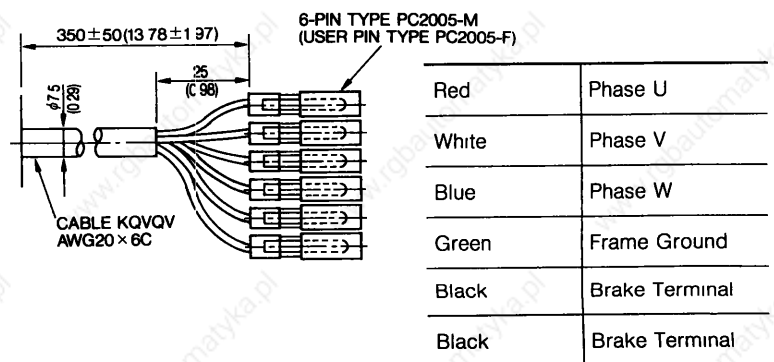

(b) Detector side (absolute encoder)

1	Channel A output	Blue	9	Frame ground	Green/Yellow
2	Channel \bar{A} output	White/Blue	10	Channel U output	Orange
3	Channel B output	Yellow	11	Channel \bar{U} output	White/Orange
4	Channel \bar{B} output	White/Yellow	12	Channel V output	Purple
5	Channel Z output	Green	13	Channel \bar{V} output	White/Purple
6	Channel \bar{Z} output	White/Green	14	Channel W output	Grey
7	0V	Black	15	Channel \bar{W} output	White/Grey
8	5VDC	Red	—	—	—

4 6 5 Impact Resistance

When mounted horizontally and exposed to vertical shock impulses, the motor can withstand up to two impacts with impact with impact acceleration of 50G (Fig 4 10)

NOTE

A precision detector is mounted on the oppositedrive end of the AC SERVOMOTOR Care should be taken to protect the shaft from impacts that could damage the detector

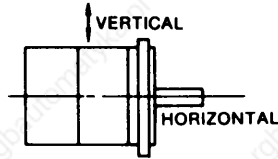

Fig 4 10 Impact Resistance

4 6 6 Vibration Resistance

When mounted horizontally, the motor can with-stand vibration (vertical, lateral, axial) of 2.5G (Fig 4 11)

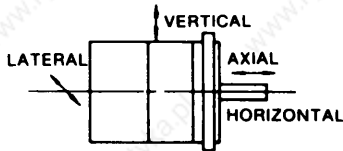

Fig 4 11 Vibration Resistance

4 6 7 Vibration Class

Vibration of the motor running at rated speed is $15\mu\text{m}$ or below (Fig.4.12)

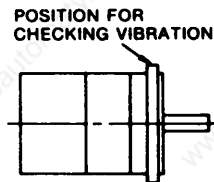

Fig. 4. 12 Vibration Checking

5. CONFIGURATION

5.1 CONNECTION DIAGRAM

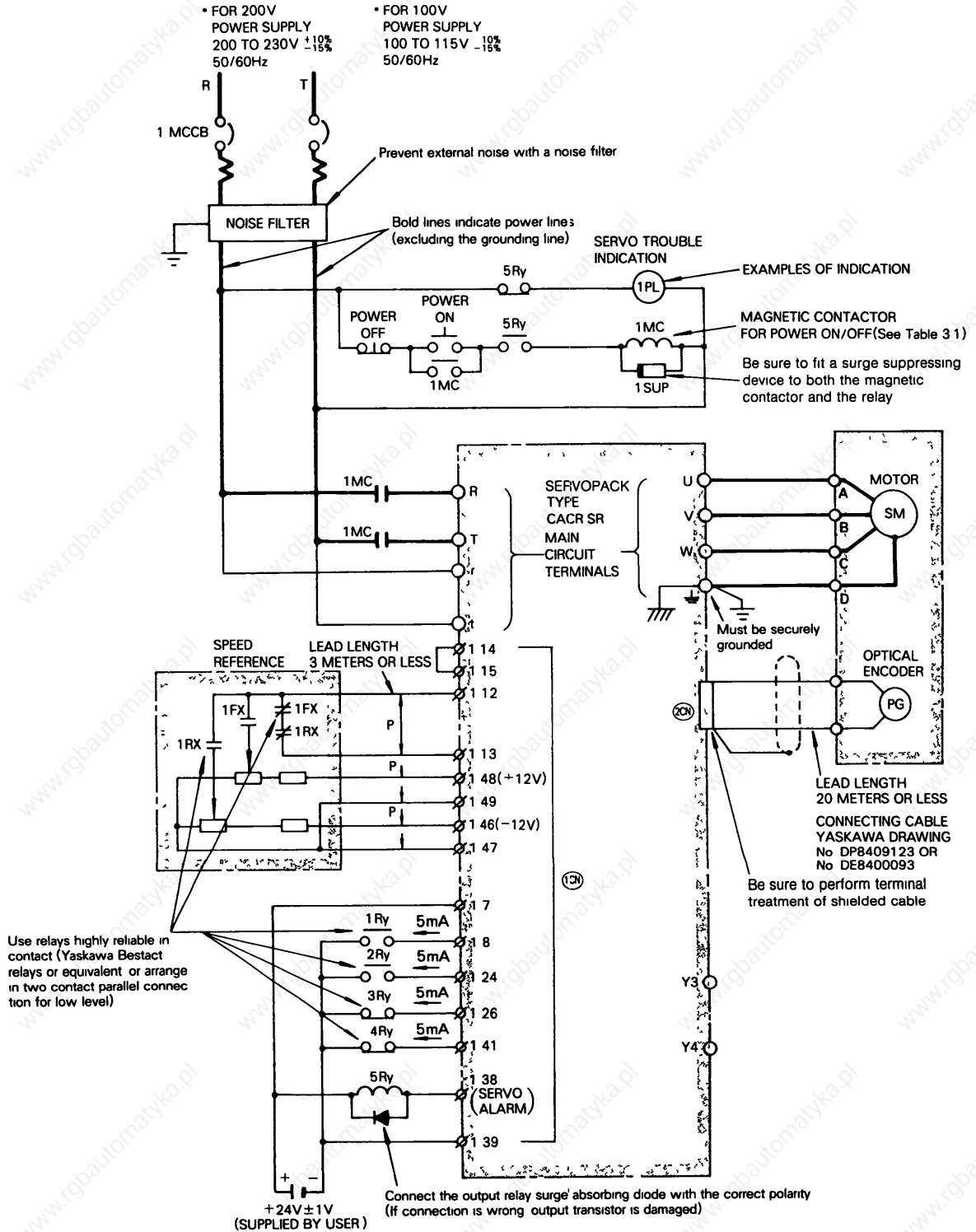

Fig 5.1 Example of Connection Diagram of SERVOPACK with a SERVOMOTOR and Peripherals

5. 2 INTERNAL BLOCK DIAGRAM

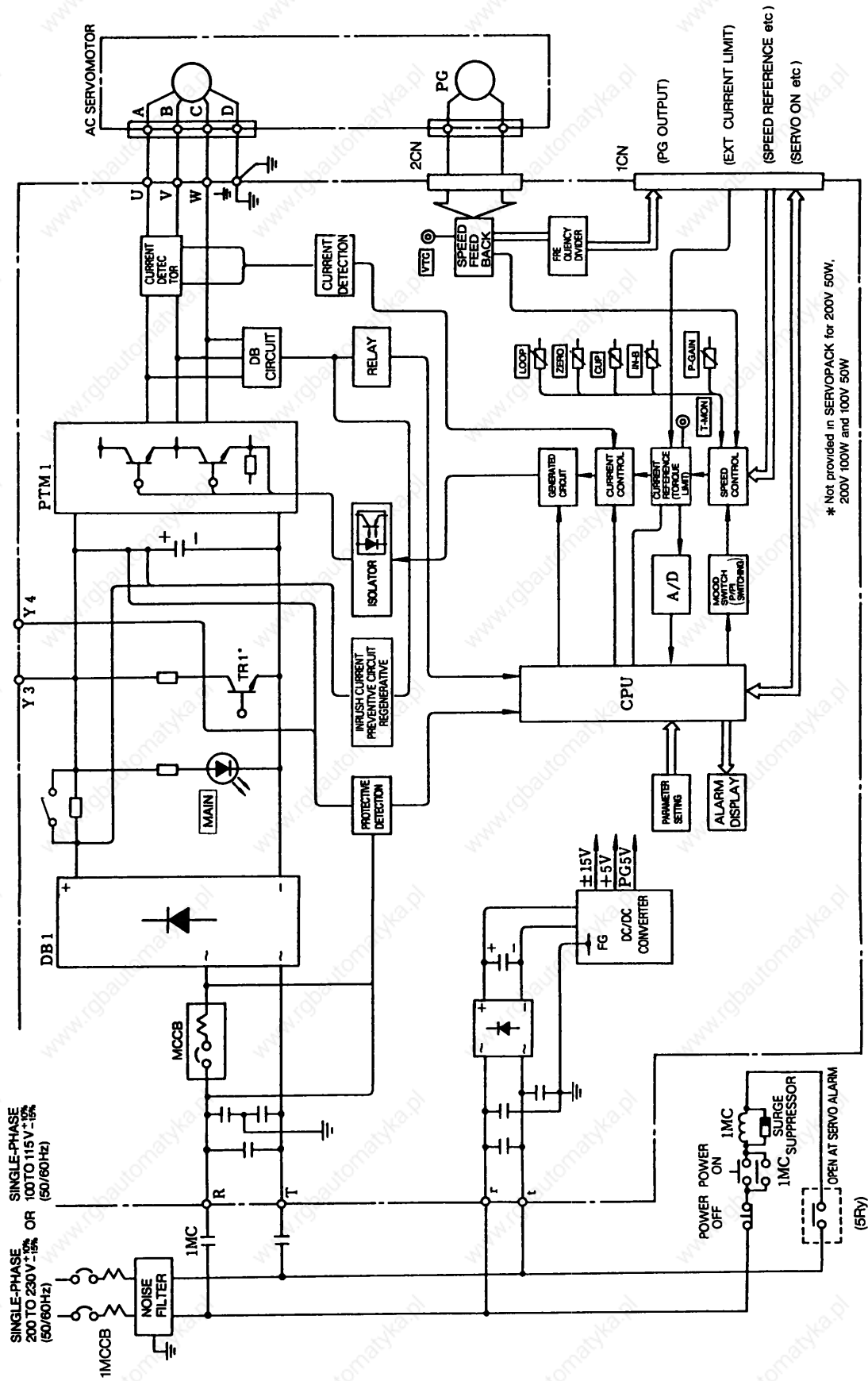

Fig. 5 2 Internal Block Diagram of SERVOPACK Type CACR-SR AC AE

5. 3 MAIN-CIRCUIT TERMINALS

Table 5 1 Main-Circuit Terminals for SERVOPACK

Terminal Symbol	Name	Description
Ⓜ Ⓣ	Main-circuit AC input	<ul style="list-style-type: none"> For 200V Single-phase 200 to 230V $\begin{matrix} +10\% \\ -15\% \end{matrix}$, 50/60Hz For 100V Single-phase 100 to 115V $\begin{matrix} +10\% \\ -15\% \end{matrix}$ 50/60Hz
Ⓤ Ⓥ Ⓦ	Motor connection	Connects terminal Ⓤ to motor terminal A Ⓥ to B and Ⓦ to C
Ⓡ Ⓢ	Control power input	<ul style="list-style-type: none"> For 200V Single-phase 200 to 230V $\begin{matrix} +10\% \\ -15\% \end{matrix}$ 50/60Hz For 100V Single-phase 100 to 115V $\begin{matrix} +10\% \\ -15\% \end{matrix}$ 50/60Hz
Ⓧ	Ground	Connects to motor terminal D Must be securely grounded
Ⓨ ₃ Ⓨ ₄	Regenerative register	External connection not normally required

5. 4 CONNECTOR TERMINAL (1CN) FOR I/O SIGNAL

5 4 1 Specifications of Applicable Receptacles

Table 5 2 Specifications of Applicable Receptacles for SERVOPACK I/O Signal

Connector Type* used in SERVOPACK	Applicable Receptacle Type			
	Manu- facturer	Soldering Type	Caulking Type	Case
MR-50RMA (Right angle 50 P)	Honda Tsushin Co., Ltd	MR-50F†	MRP-50F01	MR-50L†

*The connectors for I/O signals used are type MR-50RMA made by Honda Tsushin Co. Ltd

† Attached to SERVOPACK when shipping

5. 4 2 Connector 1CN Layout and Connection of SERVOPACK

The terminal layout of the SERVOPACK I/O signal connectors (1CN) is shown in Table 5 3

The external connection and external signal processing are shown in Fig 5 4 on page17

Table 5 3 Connector 1CN Layout of SERVOPACK

1	2	3	4	5	6	7	8	9	10	11	12	13	14	15	16	17	18	
OV	OV	OV	ALO1	CLT +	CLT -	+24V IN	S-ON	TRQ-M	VTG-M	SG	IN-A	SG-A	IN-B	SG-B	+12V	SG	FG	
OV for PG Output Signal			Alarm code 1	Current Limit Detection Output		Ext Power Input	Servo ON Power	Torque Monitor			Speed Reference Input		Auxiliary Input		+12V Output	Frame Ground		
			19	20	21	22	23	24	25	26	27	28	29	30	31	32		
			PCO	*PCO	ALO2	TG ON +	TG ON -	P-CON	PHC	N-OT	S RDY -	S-RDY +	N-CL	SG-NCL	-12V	SG		
			Line Driver Output Phase C		Alarm code 2	TG ON Output Signal		P Drive Input	Open Collector Output Phase C	Reverse Prohibit Input	Servo Ready Output		Reverse Current Limit Input		-12V Output			
33	34	35	36	37	38	39	40	41	42	43	44	45	46	47	48	49	50	
PAO	*PAO	PBO	*PBO	ALO3	ALM +	ALM -	PHB	P-OT	PHA	ALM-RST	P-CL	SG-PCL	-12V	SG	+12V	SG	FG	
Line Driver Output Phase A		Line Driver Output Phase B		Alarm code 3	Servo Alarm Output		Open Collector Output Phase B	Fwd Prohibit Input	Open Collector Output Phase A	Alarm Reset Input	Fwd Current Limit Input		-12V Output		+12V Output		Frame Ground	

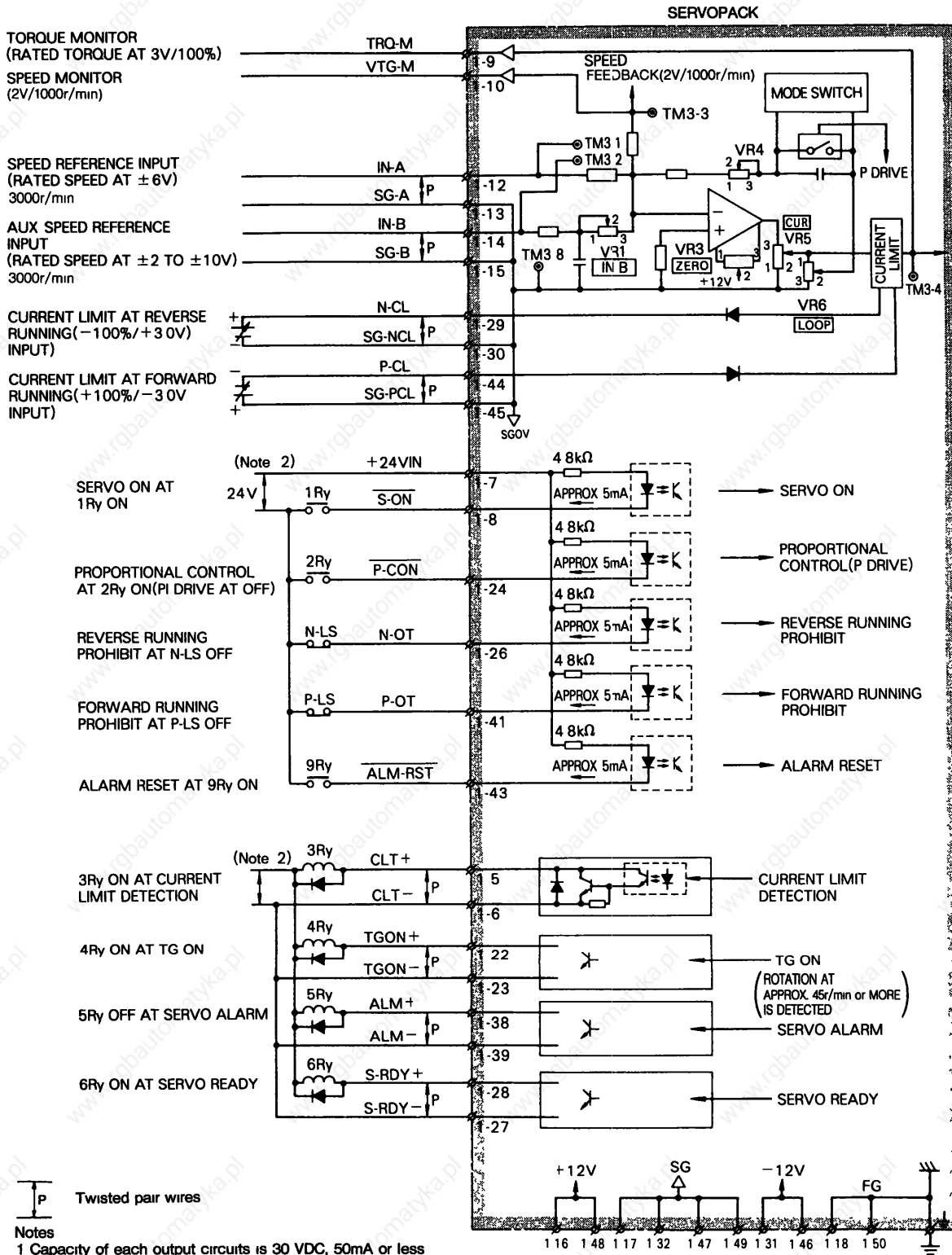

Fig 5 3 1CN I/O Signal Connection and External Signal Processing

5 4 2 Connector 1CN Layout and Connection of SERVOPACK (Cont'd)

Table 5 4 Input Signals of Connector 1CN

Signal Name	Connector 1CN No	Function	Description
$\overline{S-ON}$	8	Servo ON	Inputting this signal makes the SERVOPACK ready to receive speed reference input Base block and dynamic brake are cleared
$\overline{P-CON}$	24	Proportional drive reference	Proportional control reference to prevent drifting when the motor is left motionless without reference input, while the main circuit is kept energized
N-OT	26	Reverse running prohibit	In the case of linear drive etc connect limit switch signal according to the run direction This signal is "closed" during normal run When limit switch is tripped it becomes "open"
P-OT	41	Forward running prohibit	
+24VIN	7	24V	External power supply to 1CN-8, 24, 26, 41 and 43 Use an external 24VDC (25mA min) power supply
IN-A*	12(13)	Speed reference input	At $\pm 6.0V$, \pm rated speed is obtained
IN-B*	14(15)	Aux reference input	At ± 2.0 to $\pm 10.0V$ \pm rated speed is obtained For adjustment potentiometer [IN-B] is used
N-CL	29(30)	Current limit reference at reverse running	+3.0V $\pm 10\%/100\%$ torque +9V max
P-CL	44(45)	Current limit reference at forward running	-3.0V $\pm 10\%/100\%$ troque -9V max
ALM-RST	43	Alarm reset	This signal resets the alarm

*When either IN A or IN B is used be sure to short the unused input

Table 5 5 Output Signals of Connector 1CN

Signal Name	Connector 1CN No	Function	Description
ALM	38(39)	Servo alarm	Turns OFF when fault is detected For details, refer to Table 6 2, "Fault Detection Function"
\overline{TGON}	22(23)	Motor run detection	Turns ON when motor speed exceeds approx 45 r/min or 450 r/min The motor speed can be changed by using SW1 to 5 • 45 r/min Short-circuit SW1 to 5 • 450 r/min Open SW to 5
\overline{CLT}	5(6)	Current limit detection	• N-CL or P-CL used Turns ON when output torque reaches the level set by N-CL or P-CL • N-CL or P-CL not used Turns ON when output torque reaches the level set by potentiometer [CUR]
$\overline{S-RDY}$	27(28)	Servo ready	Turns ON when main power supply ON, and no servo alarm
+12V	16, 48	$\pm 12V$ output power supply	+12V $\pm 5\%$ max output current 30mA Used with speed reference or current limit input
0V	17, 32, 47, 49		
-12V	31, 46		
TRQ-M	9	Torque monitor	($\pm 3.0V$ /rated torque) = 10%, $\pm 9V$ max, load 1mA max
VTG-M	10	Speed monitor	($\pm 2.0V$ /1000 r/min) $\pm 5\%$, load 1mA max
PAO	33	Positioning Signal Output 1	PG pulses after frequency division are output at line driver (TI MC3487) To be received by line receiver (TI MC 3486)
*PAO	34		
PBO	35		
*PBO	36		
PCO	19		
*PCO	20		
PHA	42(1)	Positioning Signal Output 2	Open collector output, encoder output signal after frequency division Max operating voltage 30VDC Max output current 20mA DC
PHB	40(2)		
PHC	25(3)		
AL01	4(1)	Alarm code output (BCD code)	Open collector output Max operating voltage 30VDC Max output current 20mA DC
AL02	21(2)		
AL03	37(3)		

5. 5 CONNECTOR TERMINAL (2CN) FOR OPTICAL ENCODER (PG) CONNECTION

5 5 1 Specifications of Applicable Receptacles and Cables (Table 5 6)

Table 5 6 Specifications of Applicable Receptacles and Cables

Connector Type* used in SERVOPACK	Applicable Receptacle Type			Cable Specifications [‡]	
	Manufacturer	Soldering Type	Caulking Type		
MR-20RMA, right angle 20P	Honda Tsushin Co , Ltd	MR-20F [†]	MRP-20F01	MR-20L [‡]	DP8409123 or DE8400093

*Made by Honda Tsushin Co , Ltd

[†]Attached to each applicable receptacle (Soldering and caulking types)

[‡]Attached to SERVOPACK at shipment

#The cables Listed in Table 5 7 are available on request

If required, purchase in units of standard length as shown in Table 5 7

Table 5. 7 Cable Specifications

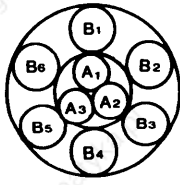
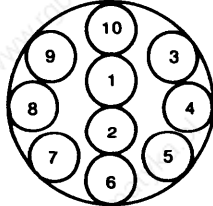
Connection	Soldered Type	Caulking Type																																						
YASKAWA Drawing No	DP 8409123	DE 8400093																																						
Manufacturer	Fujikura Cable Co																																							
General Specifications	Double, KQVV-SW AWG 22 × 3 C AWG 26 × 6 P	KQVV-SB AWG 26 × 10 P																																						
	For Soldering Type	For Caulking Type																																						
																																								
Internal Composition and Lead Color	<table border="1"> <tr><td>A₁</td><td>Red</td></tr> <tr><td>A₂</td><td>Black</td></tr> <tr><td>A₃</td><td>Green yellow</td></tr> <tr><td>B₁</td><td>Blue White/blue</td></tr> <tr><td>B₂</td><td>Yellow White/yellow</td></tr> <tr><td>B₃</td><td>Green White/green</td></tr> <tr><td>B₄</td><td>orange White/orange</td></tr> <tr><td>B₅</td><td>Purple White/purple</td></tr> <tr><td>B₆</td><td>Grey White/grey</td></tr> </table>	A ₁	Red	A ₂	Black	A ₃	Green yellow	B ₁	Blue White/blue	B ₂	Yellow White/yellow	B ₃	Green White/green	B ₄	orange White/orange	B ₅	Purple White/purple	B ₆	Grey White/grey	<table border="1"> <tr><td>1</td><td>Blue-White</td></tr> <tr><td>2</td><td>Yellow-White</td></tr> <tr><td>3</td><td>Green-White</td></tr> <tr><td>4</td><td>Red-White</td></tr> <tr><td>5</td><td>Purple-White</td></tr> <tr><td>6</td><td>Blue-Brown</td></tr> <tr><td>7</td><td>Yellow-Brown</td></tr> <tr><td>8</td><td>Green-Brown</td></tr> <tr><td>9</td><td>Red-Brown</td></tr> <tr><td>10</td><td>Purple-Brown</td></tr> </table>	1	Blue-White	2	Yellow-White	3	Green-White	4	Red-White	5	Purple-White	6	Blue-Brown	7	Yellow-Brown	8	Green-Brown	9	Red-Brown	10	Purple-Brown
A ₁	Red																																							
A ₂	Black																																							
A ₃	Green yellow																																							
B ₁	Blue White/blue																																							
B ₂	Yellow White/yellow																																							
B ₃	Green White/green																																							
B ₄	orange White/orange																																							
B ₅	Purple White/purple																																							
B ₆	Grey White/grey																																							
1	Blue-White																																							
2	Yellow-White																																							
3	Green-White																																							
4	Red-White																																							
5	Purple-White																																							
6	Blue-Brown																																							
7	Yellow-Brown																																							
8	Green-Brown																																							
9	Red-Brown																																							
10	Purple-Brown																																							
	Twisted Pair wires	Twisted Pair wires																																						
YASKAWA Standard Specifications	Standard length 5 m, 10 m, 20 m Terminal ends are not provided (without connectors)																																							

NOTE

- 1 When applicable cables listed in Table 5 7 are used, allowable wiring distance between SERVOPACK and motor is a maximum of 20meters
- 2 The cable applied for 50m wiring distance is available on order (YASKAWA drawing No DP8409179) If wiring distance is 20 m or more, contact your YASKAWA representative.
- 3 Cables must be assembled by authorized vendor with appropriate tooling

5 5 2 SERVOPACK Connector (2CN) Terminal Layout and Connection

The terminal layout for the SERVOPACK connectors (2CN) for connecting the optical encoder is shown in Table 5 8, and the connection method of 2CN and the optical encoder, in Figs. 5 4 and 5 5

Table 5 8 Connector 2 CN Layout of SERVOPACK

1	2	3	4	5	6	7
PG0V	PG0V	PG0V	PG5V	PG5V	PG5V	DIR
	8	9	10	11	12	13
	PU	*PU	PV	*PV	PW	*PW
14	15	16	17	18	19	20
PC	*PC	PA	*PA	PB	*PB	FG

Note For DIR, see Par 6 9 1

5 5 2 SERVOPACK Connector (2CN) Terminal Layout and Connection (Cont'd)

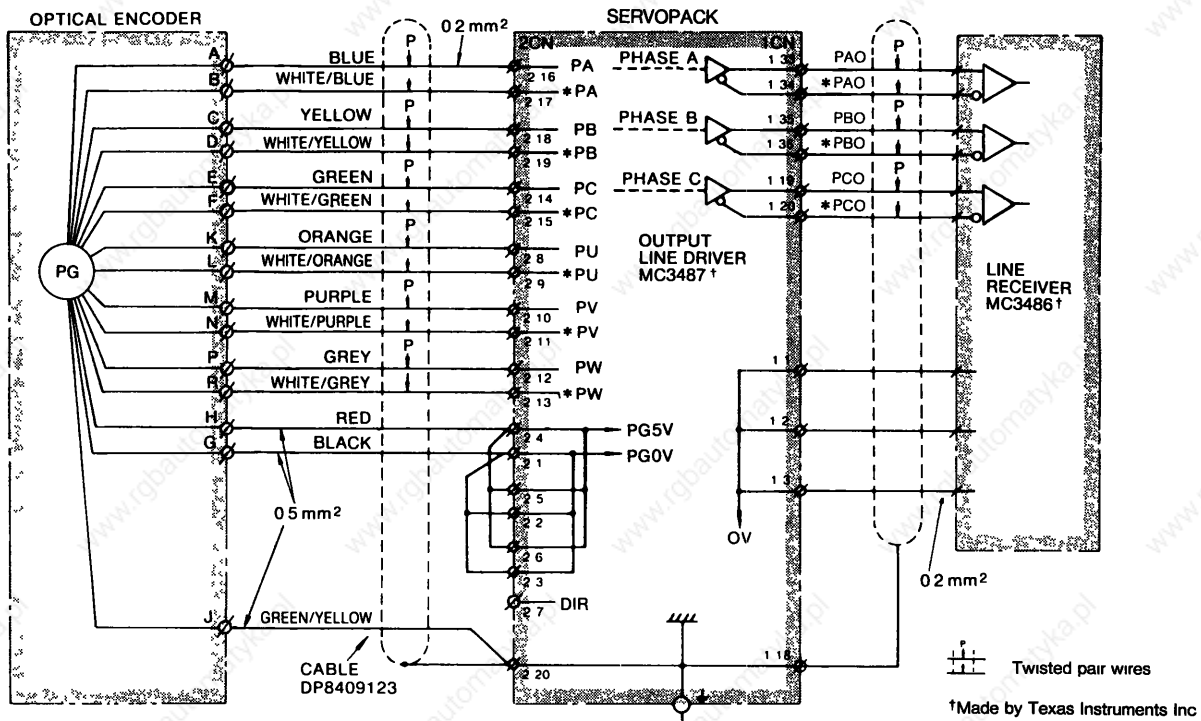

Note Connector specifications of optical encoders are as follows
 Connector – Type MS3102A20-29P (Receptacle)
 Accessory (not attached) – Type MS3108B20-29S (Angle plug)
 Type MS3057-12A (Cable clamp)

Fig 5 4 R Series Soldering Type Connector 2CN Connection and 1CN Output Processing (When using Connection Cable DP8409123)

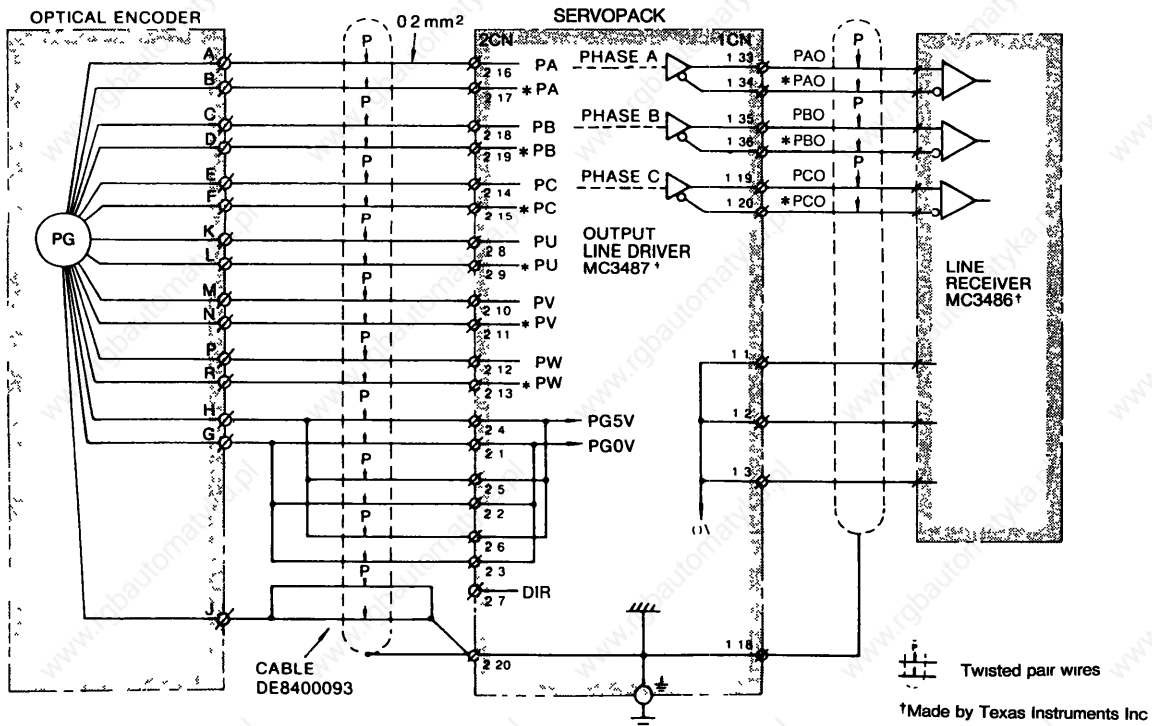

Note Connector specifications of optical encoder are as follows
 Connector – Type MS3102A20-29P (Receptacle)
 Accessory (not attached) – Type MS3108B20-29S (Angle plug)
 Type MS3057-12A (Cable clamp)

Fig 5 5 R Series Caulking Type Connector 2CN Connection and 1CN Output Processing (When using Connection Cable DE8400093)

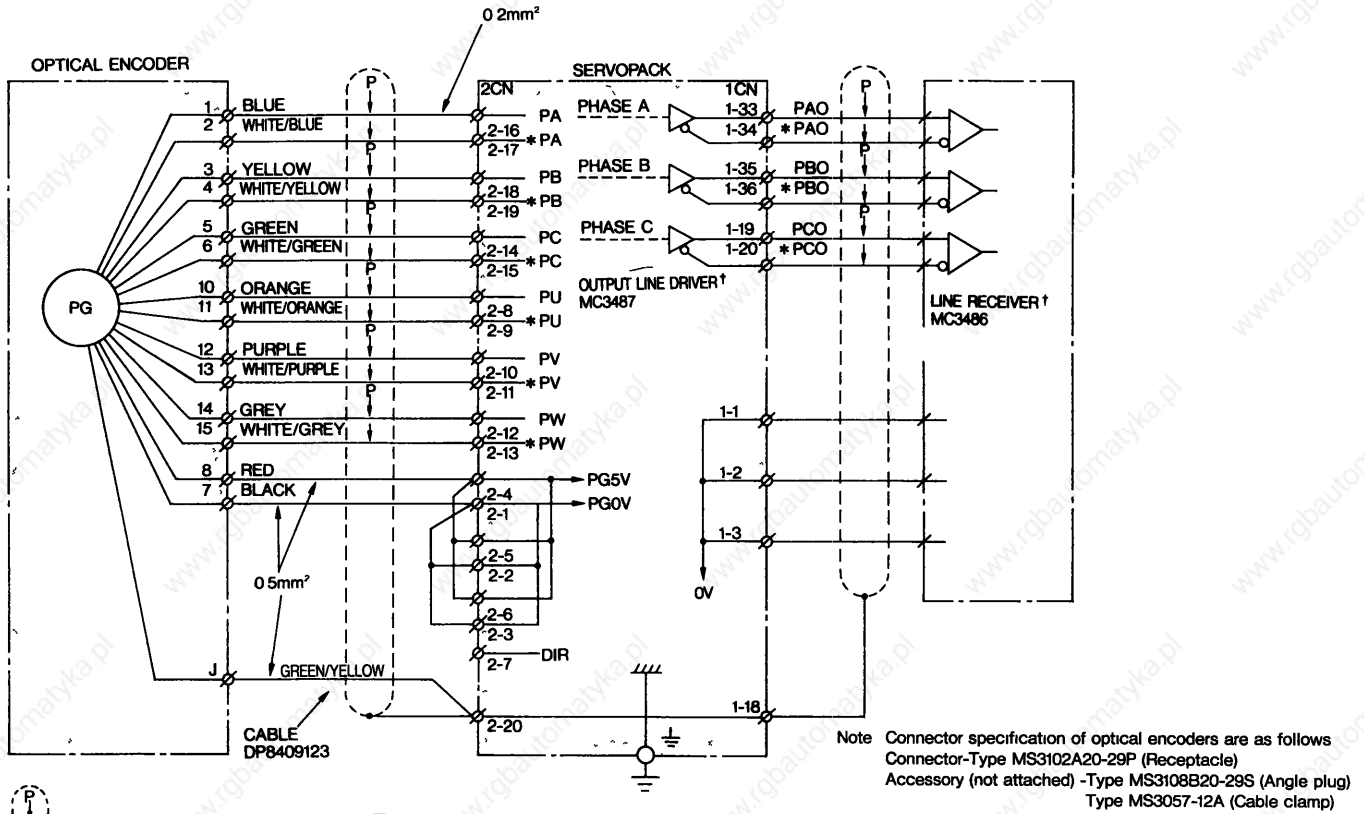
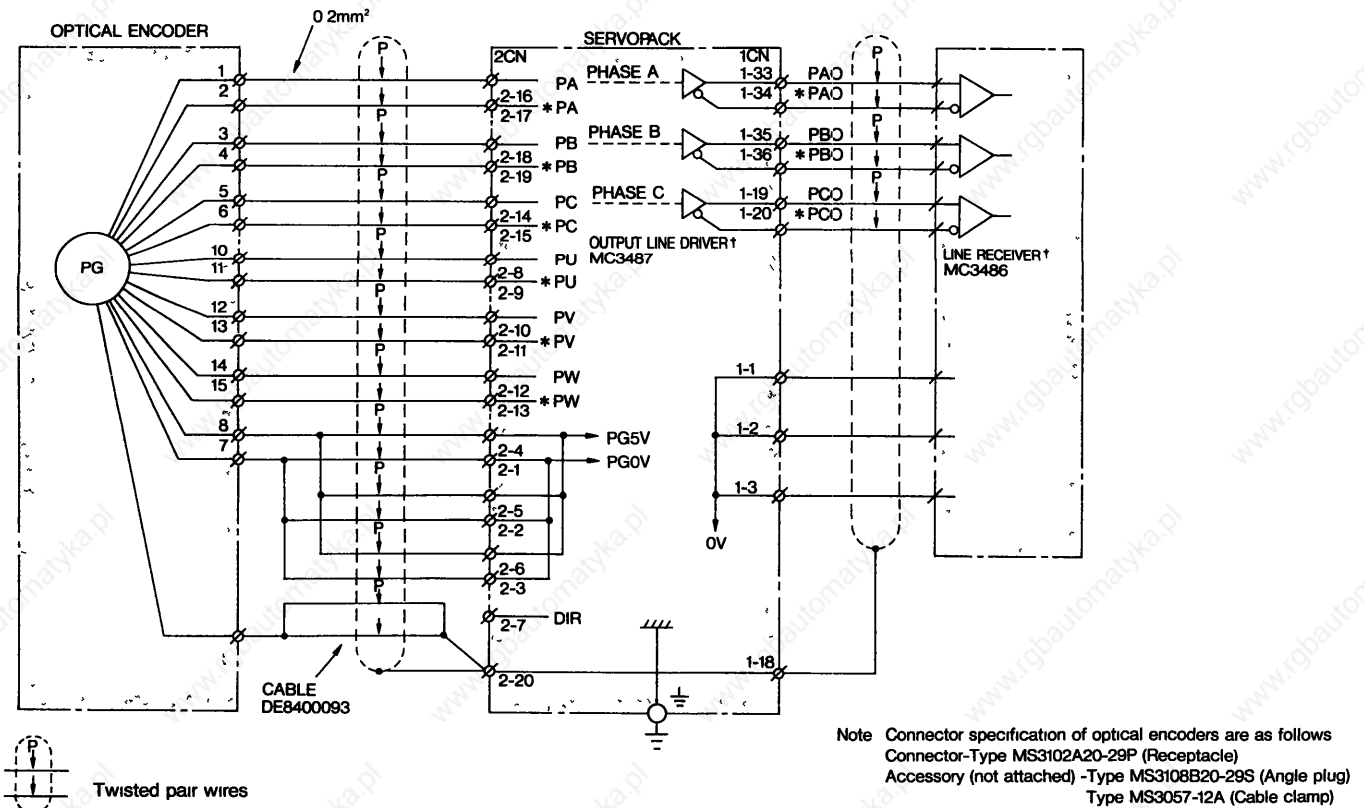

Fig. 5. 6 P Series Soldered Type Connector 2CN Connection and 1CN Output Processing (When using Connection Cable DP8409123)



† Made by Texas Instruments Inc



† Made by Texas Instruments Inc

Fig 5. 7 P Series Soldered Type Connector 2CN Connection and 1CN Output Processing (When using Connection Cable DE8400093)

6. OPERATION

6. 1 POWER ON AND OFF

Arrange the sequence so that the power is simultaneously supplied to the main circuit (R,T) and the control circuit (r,t), or supplied to the control circuit first, then the main circuit (Figs 6 1 and 6 2)

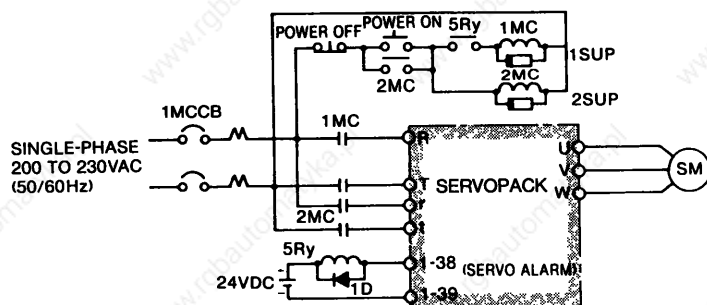
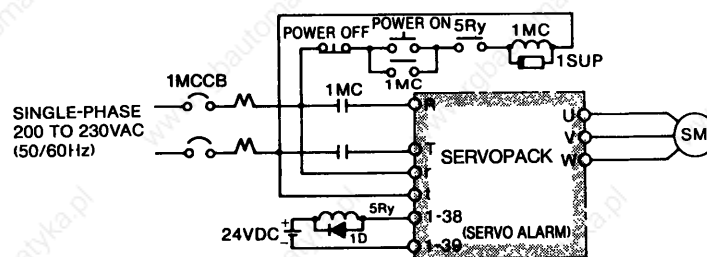

Fig 6 1 Connection Example for Simultaneous Control Power ON/OFF (When using AC SERVOMOTOR for 200 V)



1SUP, 2SUP Surge suppressor
1D Freewheel diode (to prevent 5Ry spike)

Fig 6 2 Connection Example for Main-circuit Power ON/OFF (When using AC SERVOMOTOR for 200 V)

Arrange the sequence so that the power is simultaneously cut (including momentary power failure) (Fig 6 1) or the power to the main circuit is first, then the control circuit (Fig 6 2) The order is the reverse of the power ON sequence

Precautions for connections (in Figs 6 1 and 6 2)

- Make sequence to assure that the main-circuit power will be cut off by a servo alarm signal
If the control circuit is turned OFF, the LED indicating the kind of servo alarm also goes OFF
- When power is supplied to the power ON/OFF sequence shown in Fig 6 1, the normal signal is set (5Ry is turned on) in the control circuit after a maximum delay of 1 second

When the power is turned ON, a servo alarm signal continues for approximately 1 second (normally 200 to 300 ms) to initialize the SERVOPACK

Hold the main-circuit power ON signal for approximately 1 second However, this is unnecessary in the sequence in Fig 6 2, because the control power is always turned ON

- Since SERVOPACK is of a capacitor input type, large in-rush current flows when the main-circuit power is turned ON (recharging time 0.2s) If the power is turned ON and OFF frequently, the in-rush current limit resistor may be degraded and a malfunction may occur When the motor starts, turn ON the speed reference and turn it OFF when the motor stops Do not turn the power ON or OFF

Before power ON or OFF, turn OFF the "SERVO ON" switch to avoid troubles at transient state

6. 2 SPEED REFERENCE

6. 2 1 Speed Reference Circuit

From the SERVOPACK built-in control power(1CN-⑫, ⑬ + 12 V, 1CN-⑭, ⑮, ⑯ 0 V, 1CN-⑰, ⑱ -12 V) or the external power, the speed reference voltage is given to 1CN-⑫ and ⑬ or to 1CN-⑭ and ⑮. When the SERVOPACK built-in control power is used, the motor speed fluctuates in the range of $\pm 2\%$ of the speed set value.

The method for giving speed reference voltage is described below.

(1) For accurate(inching) speed setting

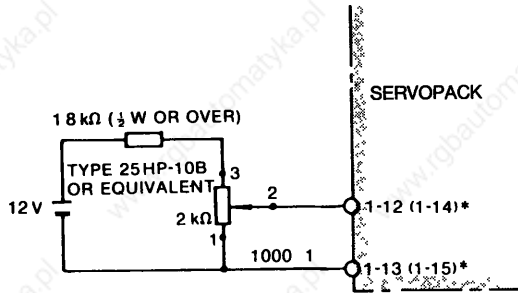

25HP-10B type Multiple-rotation type wire wound variable resistor (with dial MD10-30B4) made by Sakae Tsushin Inco

(a) When Multiple-rotation Type, Wire-Wound, Variable Resistor is used

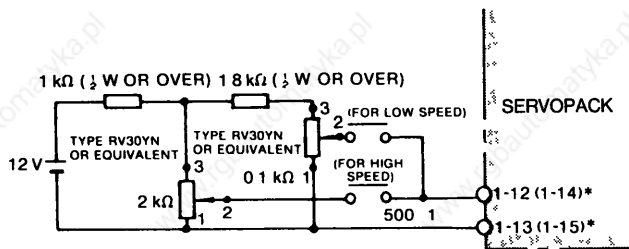

RV30YN type Carbon-film variable resistor made by Tokyo Cosmos Electric

Low-and high-speed relays Reed relay (PG series) or low-level relay (G₂A-432)

Note When a carbon resistor is used, great residual resistance remains, so the speed control range becomes approximately 500:1

(b) When Carbon Variable Resistor is used

* Parentheses are for auxiliary input

Fig 6 3 Method for Giving Speed Reference Voltage (for Accurate Speed Setting)

(2) For relatively rough speed setting

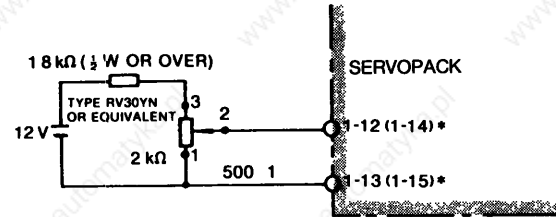

* Parentheses are for auxiliary input

Note When a carbon resistor is used, a great residual resistance remains and so the speed control range becomes about 500:1

Fig 6 4 Method for Giving Speed Reference Voltage (for relatively Rough Speed Setting as compared with Fig 6 3)

6 2 2 Stop Reference Circuit

When commanding a stop, do not open the speed reference circuit (1CN-⑫ or 1CN-⑬), but set to 0 V

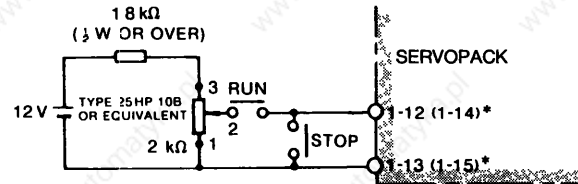

(a) When Multiple-rotation Type, Wire Wound Variable Resistor is used

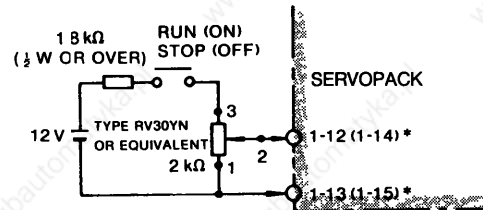

(b) When Carbon Variable Resistor is used

* Parentheses are for auxiliary input

Fig 6 5 Method for Giving Stop Reference

6 2 3 Handling of Speed Reference Input Terminal

The unused terminals, out of the speed reference terminals 1CN-⑫, ⑬ and the auxiliary input terminals 1CN-⑭, ⑮ must be short-circuited

6 2 4 Auxiliary Input Circuit (± 2 to ± 10 V)

Auxiliary input circuit is used for application at rated reference voltage other ± 6 V

Adjustment procedures

Between 1CN-⑭ and ⑮ (⑮ is 0 V), input the voltage to be used to set the rated speed, and adjust the potentiometer **IN-B** so that the rated speed is achieved

When combined with YASKAWA POSITIONPACK in positioning system drive, auxiliary input terminals are normally used as speed reference input. In this case, positioning loop gain is adjusted with the potentiometer 1 VR **IN-B**. For adjustment, be sure to refer to POSITIONPACK instruction manuals

6. 3 EXTERNAL CURRENT LIMIT REFERENCE CIRCUIT [P-CL, N-CL]

Current can be limited from the outside as well as within SERVOPACK. The external current limit is used for the following cases

- To protect the motor from overload current when an abnormal load lock occurs in the load
- To change the current limit value according to the external sequence

The current can be limited by multi-stage setting by the use of relays (Fig.6.6). The same effect can be obtained by giving voltage signals making analog change

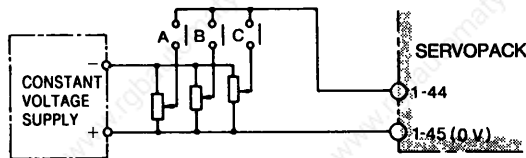

Relay Low-level relay type G2A-432A made by OMRON Corporation

Fig 6 6 Multi-stage Switching of Current Value at Forward Side

6 3 1 Method for Giving External Current Limit Reference

Forward current and reverse current can be controlled independently. The forward current can be controlled by giving a reverse voltage (0 to -9.0 V) between SERVOPACK terminals 1CN-④ and ⑤, the reverse current can be controlled by a forward voltage (0 to +9.0 V) between terminals 1CN-② and ③.

The relation between the rated current of the motor and current limit values is rated current at 3.0 V for applicable motor. The power supply must use an internal resistance less than 2kΩ. The input resistance at SERVOPACK side must be greater than 5kΩ. When external current is not restricted, contacts between terminals 1CN- ④ and ⑤ and between 1CN- ② and ③ are opened.

6 3 2 Set Voltage and Current Limit Values

The relationship between set voltages of 0 to ±9.0 V and current limit values are shown in Fig.6.7.

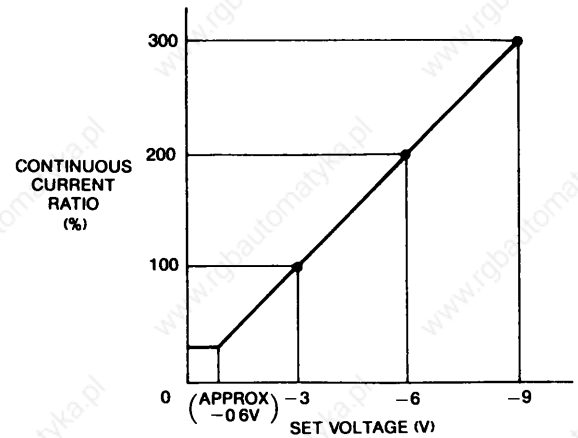

(a) Current Limit at Forward Side

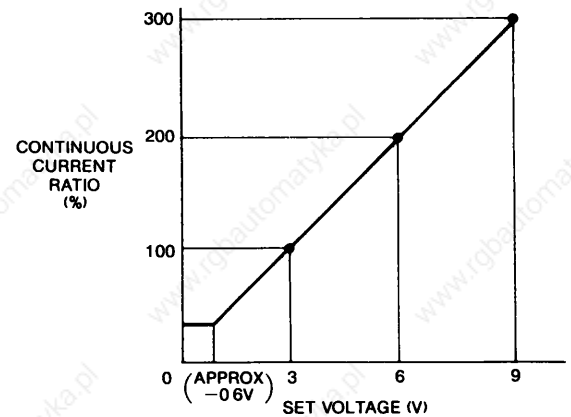

(b) Current Limit at Reverse Side

Note: If setting value exceeds max output current value of Servopack, max output current value becomes saturation value.

FIG 6 7 Set Voltage and Current Limit Values

6 3 3 Current limit when Motor is Locked

When locking a motor by applying a current limit, determine a current limit value less than the 70 % of rated current of the motor. If the load condition requires a current limit exceeding the rated motor current, refer to par. 6 5(3) Overload detection level and make sure to unlock the motor before reaching the trip level.

Note that when the speed reference voltage is less than tens or so millivolts (affected by setting of GAIN LOOP), the motor lock current sometimes pulsates. If this is not desirable, the current pulsation can be removed by increasing the speed reference voltage.

6. 4 CONFIGURATION OF I/O CIRCUIT

For proportional drive, overtravel, servo ON, alarm reset, servo alarm output, current limit detection output, TG ON, servo ready output, etc , each I/O circuit is a noncontact circuit insulated with optical couplers. The external circuit, therefore, must be constructed with the specified voltage and current

6 4 1 Input Circuit

There are five input signals Servo ON, proportional drive reference, forward/reverse overtravel protection, alarm reset. Construct the input circuit using 24 V power supply (Fig 6 8). Typical circuits are shown in Fig 5 3

NOTE

The user must provide the 24 V power supply 24 VDC ± 1 V, 25mA or more (approx 5mA/circuit)

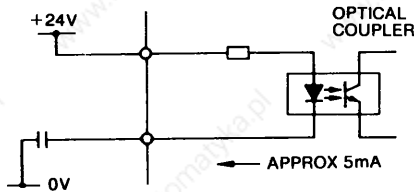

Fig 6 8 Configuration of I/O Circuit

(1) Proportional Drive Reference [P-CON]

If a position loop is not set for positioning, and after completion of positioning, has been left for quite a long time, the positioned point may have moved due to preamplifier drift. To avoid this, switch the speed amplifier from PI drive to P drive after the positioning and the loop gain in the control systems drops and the drift decreases. With several percent of friction load, the motor stops completely.

(2) Forward and reverse running prohibit [P-OT, N-OT]

These circuits prohibit motor drive in forward rotation (counterclockwise rotation viewed from the load coupling side) and in reverse rotation.

By inputting the P-OT or N-OT signal, the circuit stops drive of the rotating motor and energizes the built-in dynamic brake to stop the motor. After stopping, the motor can be operated only in a resetting direction. However, drive is not possible on the instruction to operate to the OT side.

The P-OT and N-OT operation specification is as follows

	Side P Power-ON TR	Side N Power-ON TR	Operable Direction	Display
During P-OT	Base cut off	Power on	Side N	
During N-OT	Power on	Base cut off	Side P	

Note Operation in a reverse direction is possible for both sides P and N after cutting off the base and releasing DB during DB operation after P/N-OT

NOTE

When the overtravel prevention circuit is not used, connect 1CN- (26) and (41) to the 0 V terminal of the external 24 V power supply

(3) Servo ON [S-ON]

This circuit is used to turn on the main-circuit power-drive circuit of the SERVOPACK. When the signal of the circuit is not input (Servo OFF state), the motor cannot be driven. If this signal is applied during motor running, the motor will coast to stop.

NOTE

Before turning power ON or OFF, turn OFF the "Servo ON" switch to avoid troubles resulting from transient current.

(4) Alarm reset [ALM-RST]

This is the input to reset a servo alarm state other than the overcurrent alarm (Display)

Turn OFF control power temporarily to reset the servo alarm if an overcurrent al () occurs

6 4. 2 Output Circuit

There are four output signals. Current limit detection, TG ON, Servo alarm, Servo ready.

These output circuits are non-contact, employing transistors. Voltage and current specifications are:
Applied Voltage (V_{max}) ≤ 30 V
Conduction Current (I_p) ≤ 50 mA

NOTE

The output circuit requires a separate power supply. It is recommended to use the same 24 V power supply used for the input circuit (Fig 6 9).

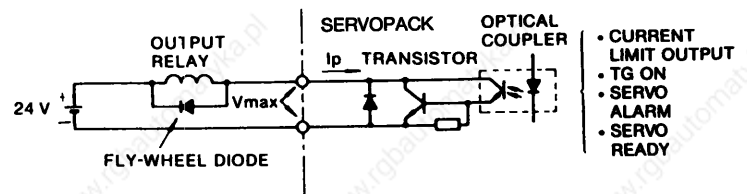

Fig 6 9 Output Circuit

6 4 3 Optical Encoder (PG) Output Circuit
 [PAO, *PAO, PBO, *PBO, PCO, *PCO]

Phases A, B, and C (original point) signals for the optical encoder, PG are output

USE these signals as positioning signals

The output signal specifications are as follows

(1) Signal form

- Two-phase pulse with 90° pulse difference (phases A and B)
- Original point pulse (phase C)

(2) Output circuit and receiver circuit

Two types of output circuits are provided line driver output and open collector output.

Fig 6 10 shows an example of line driver output

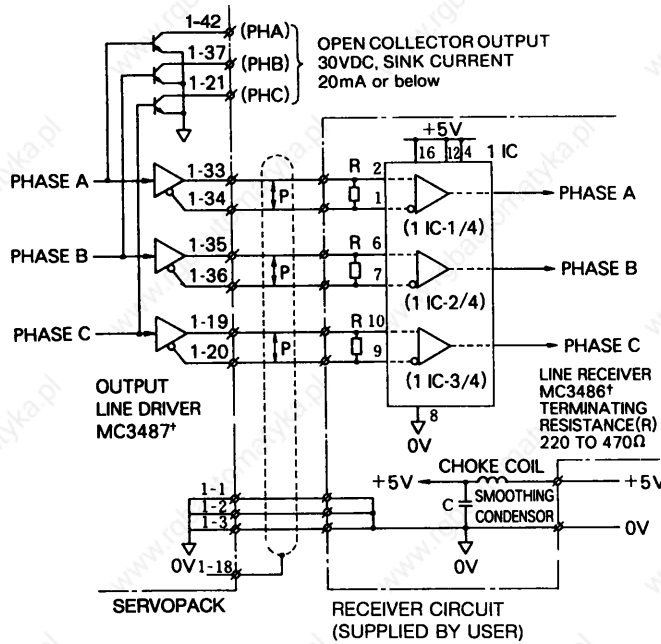

Twisted pair wires

† Made by Texas Instruments Inc

Fig 6 10 Output Circuit and Receiver Circuit

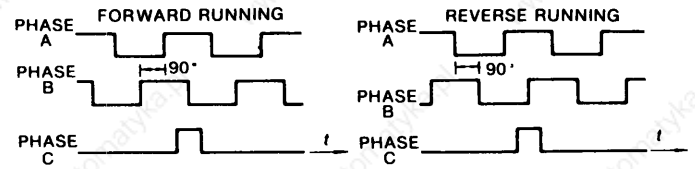

Note Phase C (original point pulse) is synchronized with phase A

Fig 6 11 Output Phase

(4) Pulse resolution

The pulse frequency of the PG can be further divided by using the divider in the SERVOPACK

The phase relation is the same as in (3), above Set the pulse frequency dividing ratio according to Table 6 1 Fig 6 12 shows the optical encoder output waveform under the dividing pulse frequency

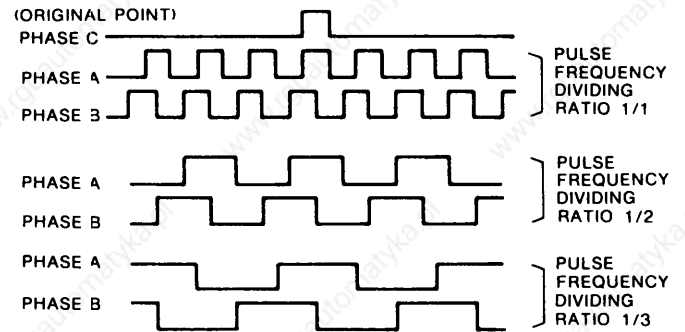

Fig 6 12 Output Waveform of Optical Encoder

Table 6 1 Setting of PG Pulse Frequency Dividing Ratio

SW2*	0†	1	2	3	4	5	6	7	8	9	A	B	C	D	E	F
Pulse Frequency Dividing Ratio	1/1	1/2	1/3	1/4	1/5	1/6	1/10	1/12	1/15	1/20	1/30	2/3	2/5	—	—	—

* Hexadecimal digital switch

† Initial setting

6. 5 PROTECTIVE CIRCUIT

SERVOPACK provides functions to protect the body and motor from malfunctions

(1) Dynamic brake function

SERVOPACK incorporates a dynamic breke for emergency stop This brake operates when

- Alarm (fault detection) occurs
- Servo ON command is opened
- Main power supply is turned off
- During deceleration at P/N overtravel

(2) Trouble detecting functions

Table 6. 2 Trouble Detecting Functions

Display	Trouble	Detection
1.	Overcurrent	Overcurrent flow in the main circuit
2.	Circuit Protector Trip	Circuit protector tipped
3.	Regeneration Trouble	Regenerative circuit not activated in SERVOPACK <ul style="list-style-type: none"> • R Series For 200V : only 200 to 700W For 100V : only 100 to 500W • P Series For 200V : 100 to 700W
4.	Overvoltage	Excessively high DC voltage in the main circuit <ul style="list-style-type: none"> • For 200V : Approx 420V • For 100V : Approx 220V
5.	Overspeed	Excessively large speed reference input (detected at approx 4900rpm)
6.	Voltage Drop	Low DC voltage in the main circuit after power ON <ul style="list-style-type: none"> • For 200V : Approx 150V • For 100V : Approx 75V
7.	Overload	Overload condition of motor and SERVOPACK
8.	A/D Error	Element error on the printed circuit board of SERVOPACK
9.	Overrun Prevention	Wrong wiring of motor circuit or PG signal line
-	CPU Error	Any error of CPU

(3) Overload (OL) detection level

Fig 6 13 shows the setting of overload detection level at 100% rated motor current The higher the moter speed is the quicker the motor responce to the same overload at 200% rated current or more.

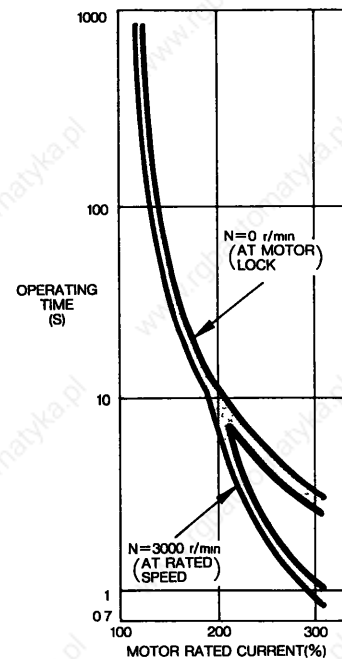

Fig. 6. 13 Overload Characteristics

(4) Servo alarm output [ALM+, ALM-]

If any trouble detection circuits in Table 6 2 functions, the power drive circuit in the SERVOPACK goes OFF, 7-segment LEDs indicate the operation condition and a servo alarm signal is output

The alarm codes are also output to the external through open collector output circuits of AL01 to AL03 See Table 6 4

(5) Protective circuit operation

An alarm signal indicates some trouble. Check the cause and correct the trouble, and restart the operation Before checking the cause, turn OFF the power to the main circuit to avoid danger Apply the sequence so that the alarm signal turns OFF only the main circuit(ⓐ, ⓑ), as shown in Figs 6 1 and 6 2 This allows rapid reaction in the event of a malfunction

If the power to the control circuit (ⓒ, ⓓ) is simultaneously turned OFF, this also turns OFF the LED in the SERVOPACK indicating the cause of the alarm signal.

CAUTION

When an alarm signal cuts off only the main circuit, set the speed reference to 0 V before supplying power to the main circuit to resume the operation.

(6) Resetting servo alarm

To reset the servo alarm, turn ON the alarm reset (ALM-RST) signal of input signal, or turn OFF the control power supply once

If 1. or 7 is ON (SERVOPACK is over loaded), the reset alarm is not immediate and occurs a few minutes later

6 8 1 Noise Control (Cont'd)

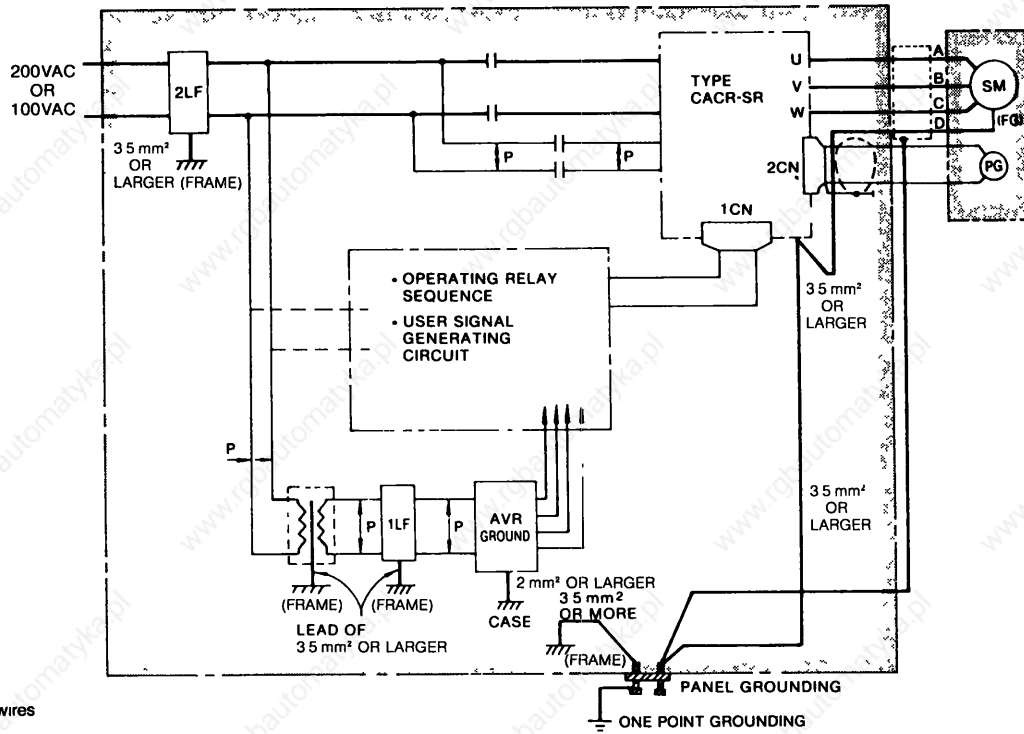

⌈P — Twisted pair wires

Notes

- 1 Use wires of 3.5mm² or larger for grounding to the case (preferably flat-woven copper wire)
- 2 Connect line filters observing the precautions as shown in (2), "Noise filter installation"

Fig 6 14 Grounding Method

(2) Noise filter installation

When noise filters are installed to prevent noise from the power line, the block type must be used. The recommended noise filter is shown in Table 6.5. The power supply to peripherals also needs noise filter.

NOTE

If the noise filter connection is wrong, the effect decreases greatly. Observing the precautions, carefully connect them as shown in Figs 6.15 to 6.18.

(a) Separate the input and output leads. Do not bundle or run them in the same duct.

Table 6.5 Recommended Noise Filter e

Class	SERVOPACK Type CACR-		Applicable Noise Filter	Recommended Noise Filter*	
	Power	Model		Type	Specifications
200V	50W (0.07HP)	SRA5AC1 R SRA5AE1 R	CORRECT	LF-205A	Single-phase 200VAC class, 5A
	100W (0.13HP)	SR01AC1 R SR01AE1 R			
	200W (0.27HP)	SR02AC1 R SR02AE1 R			
	300W (0.40HP)	SR03AC1 R SR03AE1 R			
	500W (0.67HP)	SR05AC1 R			
	700W (0.93HP)	SR07AC1 R			
100V	50W (0.07HP)	SRA5AC2 R SRA5AE2 R	WRONG	LF-205A	Single-phase 200VAC class, 5A
	100W (0.13HP)	SR01AC2 R SR01AE2 R			
	200W (0.27HP)	SR02AC2 R SR02AE2 R			
	300W (0.40HP)	SR03AC2 R			
	500W (0.67HP)	SR05AC2 R			
			LF-215	Single-phase 200VAC class, 15A	
			LF-220	Single-phase 200VAC class, 20A	

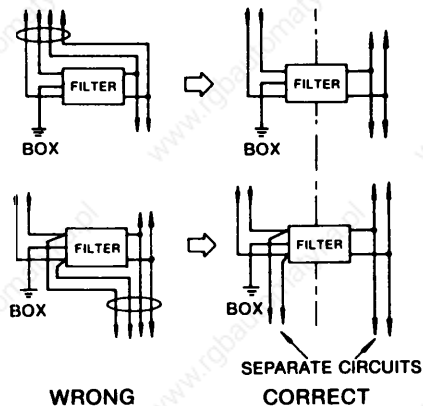

Fig 6 15

* Made by Tokin Corp
If noise filter is required request your YASKAWA representative

(b) Do not bundle the ground lead with the filter output line or other signal lines or run them in the same duct

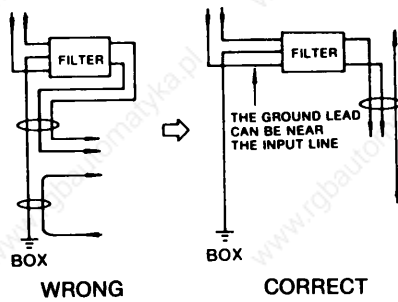

Fig 6 16

(c) Connect the ground lead singly to the box or the ground panel

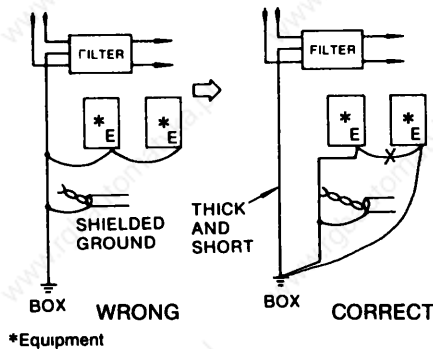

Fig 6 17

(d) If the control panel contains the filter, connect the filter ground and the equipment ground to the base of the control unit

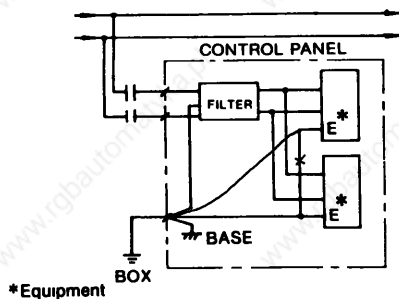

Fig 6 18

6 8 2 Power Line Protection

The SERVOPACK is operated through the commercial power line (200 V or 100 V). To prevent the power line accidents due to grounding error, contact error, or to protect the system from a fire, circuit breakers (MCCB) or fuses must be installed according to the number of SERVOPACKS used (Table 6 6).

A fast blow fuse cannot be used, because of the in-rush current

Table 6 6 Power Supply Capacity and MCCB or Fuse Capacity

Class	Rated Output W (HP)	SERVOPACK Type CACR-	Power Capacity* per SERVOPACK kVA	Current Capacity† per SERVOPACK A
200V	50(0 07)	SRASAC1 SRASAE1	0.3	5
	100(0 13)	SR01AC1 SR01AE1	0.5	5
	200(0 27)	SR02AC1 SR02AE1	0.75	5
	300(0 40)	SR03AC1 SR03AE1	1.0	10
	500(0 67)	SR05AC1	1.4	15
	700(0 93)	SR07AC1	2.0	15
100V	50(0 07)	SRASAC2 SRASAE2	0.3	5
	100(0 13)	SR01AC2 SR01AE2	0.5	5
	200(0 27)	SR02AC2 SR02AE2	0.75	10
	300(0 40)	SR03AC2	1.0	15
	500(0 67)	SR05AC2	1.4	15

* Values at rated load

† Interruption characteristics at 25°C 200 % 2 s or more
700 % 0.01 s or more

Note

Use a ground fault interrupter of high-frequency type
However, time-delay type is not applicable

6. 9 APPLICATION

6 9 1 Connection for Reverse Motor Running

If the machine construction requires that the normal forward reference is used for reverse motor running and the normal reverse reference for forward running, short circuit across 2CN-1 and 2CN-7 of connector 2CN for the PG. In this case, change of motor and PG connection is not required. For forward reference, frequency dividing output from SERVOPACK forwards B-phase.

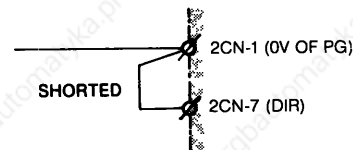

Fig 6 19

Note

Set CN2 1 and CN2-7 to be connected to the closest connectors using the shortest distance at the cable side (MR-20F or MRP-20FO1)
Using a long cable causes malfunction by noise

6 9 2 Speed and Torque Measurement

When an instrument is connected to measure speed and torque, make the connection as shown in Fig 6 20, using a DC ammeter of ± 1 mA load at full-scale voltage (both swing).

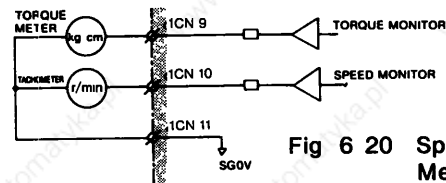

Fig 6 20 Speed and Torque Measurement

- Torque monitor output (1CN-9) ± 3.0 V $\pm 10\%$ / 100% torque
- Speed monitor output (1CN-10) ± 2.0 V $\pm 5\%$ / 1000 rpm
- Instrument DC ammeter of ± 1 mA load at full-scale voltage (both swing) Use ammeter of DCF-6 or DCF-12N by Toyo Instrument or equivalent

- Example When an R Series motor (rated speed 3000 r/min) is used, and speeds are to be measured up to the maximum speed (4500 r/min) in both directions, use $\pm 9V$ (both swing) DC voltmeter

6 9 3 Use of SERVOMOTOR with Holding Magnetic Brake

When SERVOMOTOR with magnetic holding brake is used, execute the following timing for signals ON and OFF. The magnetic holding brake is released by current conduction.

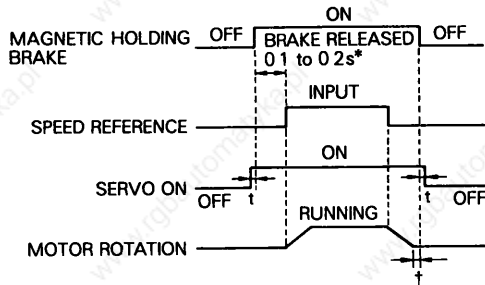

- *Input speed reference after waiting 0.1 to 0.2 second after the brake release reference has been input
- *Apply brake after the motor has stopped completely (Do not use the brake to decelerate the motor)
- Note: t shows a delay time greater than the operating time (10ms) of one relay. After Servo ON signal is turned on, the motor will enter servo lock status after approx. 30 ms.

Fig 6 21 Magnetic Holding Brake ON-OFF Timing

7. INSTALLATION AND WIRING

7. 1 RECEIVING

This motor has been put through severe tests at the factory before shipment. After unpacking, however, check and see the following:

- Its nameplate ratings meet your requirements
- It has sustained no damage while in transit
- The output shaft should be hand-rotated freely. However, motors with holding brake do not rotate.
- Fastening bolts and screws are not loose.

If any part of the motor is damaged or lost, immediately notify us giving full details and nameplate data.

7. 2 INSTALLATION

7. 2 1 SERVOMOTOR

AC SERVOMOTOR can be installed either horizontally or vertically.

(1) Before mounting

Wash out anticorrosive paint on shaft extension and flange surface with thinner before connecting the motor to the driven machine. See Fig. 7 1.

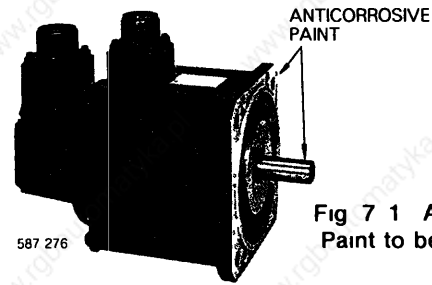

Fig 7 1 Anticorrosive Paint to be Removed

(2) Location

Use the motor under the following conditions:

- Indoors
- Free from corrosive and/or explosive gases or liquids
- Ambient temperature: 0 to $+40^{\circ}C$
- Accessible for inspection and cleaning

If the AC SERVOMOTOR is subject to excessive water or oil droplets, protect the motor with a cover. The motor can withstand a small amount of splashed water or oil.

(3) Environmental conditions

Ambient Temperature: 0° to $+40^{\circ}C$

Storage Temperature: -20° to $+80^{\circ}C$

Humidity: 20% to 80% RH (non-condensing)

(4) Load coupling

True alignment of motor and driven machine is essential to prevent vibration, reduced bearing and coupling life, or shaft and bearing failures.

Use flexible couplings for direct drives. The alignment should be made in accordance with Fig 7 2.

When mounting coupling, ease the impact on the shaft and avoid the excessive force on the bearing.

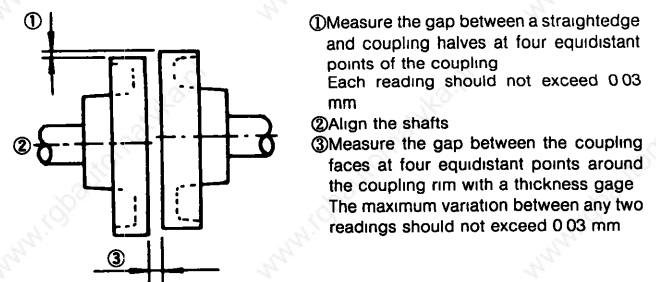

Fig 7 2 Alignment of Coupling

- ① Measure the gap between a straightedge and coupling halves at four equidistant points of the coupling. Each reading should not exceed 0.03 mm.
- ② Align the shafts.
- ③ Measure the gap between the coupling faces at four equidistant points around the coupling rim with a thickness gage. The maximum variation between any two readings should not exceed 0.03 mm.

(5) Allowable bearing load

Avoid shock to the motor shaft when mounting gear box, coupling or pulley. Don't exceed thrust and radial loads specified in Table 4 1.

7 2 2 SERVOPACK

(1) Installation

The SERVOPACK type CACR-SR [] AC and -SR [] AE are rack-mounted type

(2) Location

- When installed in a panel
 - Keep the temperature around SERVOPACK at 55°C or below
- When installed near a heat source
 - Keep the temperature around SERVOPACK below 55°C
- If subjected to vibration
 - Mount the unit on shock absorbing material
- If corrosive gases are present
 - Avoid locations where corrosive gases exist as it may cause extensive damage over long use
Especially vulnerable are switching operation of contactors and relays
- Unfavorable atmospheric conditions
 - Select a location with minimum exposure to oil, water, hot air, high humidity, excessive dust or metallic particles

(3) Mounting Direction

Mount the SERVOPACK unit vertically on the wall with main terminals being at the bottom to take advantage of natural air convection. (See Fig 7 5 (a)) Install it with setscrews tightened

at four mounting holes in the unit base To change to base-mounted type, change the support position as shown in Fig 7 5 (b) Mounting screws of base support are attached to the SERVOPACK

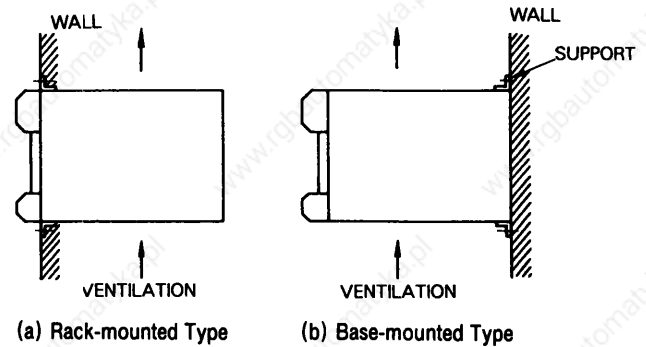

Fig 7 5 Mounting Direction

7. 3 WIRING

7. 3 1 Rated Current and Cable Size

Tables 7 1 and 7 2 show external terminals, rated current, and cable sizes of the power unit and SERVOPACK, respectively Select the type and size of cables to meet ambient conditions and current capacity The cable size is calculated so that a bundle of three cables can carry the rated current at an ambient temperature of 40°C Table 7.3 lists the type of cables

Table 7 1 Rated Current

External Terminal		Type CACR- Symbol	Rated Current (Effective Current)										
			200V Class (Type CACR-)					100V Class (Type CACR-)					
			SRA5AC1	SR01AC1	SR02AC1	SR03AC1	SR05AC1	SR07AC1	SRA5AC2	SR01AC2	SR02AC2	SR03AC2	SR05AC2
On Line	Main Circuit Power Input	Ⓡ Ⓣ	15	25	40	50	75	100	26	45	80	110	150
	Motor Connection	Ⓡ Ⓡ Ⓡ	07	10	20	27	36	57	12	17	29	36	55
	Control Power Input	Ⓡ Ⓣ	05										
Off Line	Control I/O Signal Connector	1CN	100mA DC max										
	PG Signal Connector	2CN	100mA DC max (500mA DC for power line only)										
	Ground	Ⓡ	—										

Table 7. 2 Recommended Cable Size of SERVOPACK

External Terminal		Type CACR- Symbol	Cable Size mm ² *									
			200V Class (Type : CACR-)					100V Class (Type : CACR-)				
			SRA5AC1	SR01AC1	SR02AC1	SR03AC1	SR05AC1	SR07AC1	SRA5AC2	SR01AC2	SR02AC2	SR03AC2
On Line	Main Circuit Power Input	Ⓡ Ⓣ	HIV 1 25 or more			HIV 2 0 or more		HIV 1 25 or more		HIV 2 0 or more		
	Motor Connection	Ⓡ Ⓡ Ⓡ	HIV 1 25 or more					HIV 2 0 or more	HIV 1 25 or more			HIV 2 0 or more
	Control Power Input	Ⓡ Ⓣ	HIV 1 25 or more									
Off Line	Control I/O Signal Connector	1CN	<ul style="list-style-type: none"> • Two-core twisted shielded cable • Core must be 0.2 mm² or more • Tin-plated soft-copper twisted cable • Finished cable dimension : 16 dia or less for 1CN 11 dia or less for 2CN 									
	PG Signal Connector	2CN	HIV 1 25 or more									
	Ground	Ⓡ	HIV 1 25 or more									

* Used at ambient temperature 40 °C
Apply rated current on 3 lead strands

7. 3 1 Rated Current and Cable Size (Cont'd)

Table 7 3 Cable

Type of Cable	Allowable Conductor Temperature °C
Vinyl Cable (PVC)	—
600 V Vinyl Cable (IV)	60
Special Heat-Resistant Cable (HIV)	75

Notes

- 1 For main circuits use cables of 600 V or more
- 2 Where cables are bundled or run through a duct (unplasticized polyvinyl chloride conduit or metallic conduit) select the larger cable size than listed considering the current drop rate of the cables
- 3 Where the ambient (panel inside) temperature is high (40°C to 60°C) use heat-resistant cables

7 3 2 Wiring Precautions

SERVOPACK is a device for speed control of 1000 1, and signal level of several milli-volts or less. The following precautions should be taken for wiring

(1) For signal lines and PG feedback lines, use twisted cables or multi-core shielded twisted-pair cables (YASKAWA Drawing No DP8409123 or DE8400093)

Cable length is a maximum of 3 m for reference input lines and a maximum of 20 m for PG feedback lines. Use the shortest possible length

(2) For ground line, cable should be as heavy as possible to provide class 3 ground (ground resistance 100Ω or less). Use central grounding point. If the motor and machine are insulated, ground the motor

(3) To prevent malfunction due to noise, take the following precautions

- Place the noise filter, SERVOPACK and I/O reference as near as possible to each other
- Make sure to mount a surge absorbing circuit into the relay, electromagnetic contact, and solenoid coils
- Make sure to mount a surge absorbing circuit into the relay, electromagnetic contact, and solenoid coils
- Run the power line and signal line, holding the distance to 30 cm or more, do not run them in the same duct or in a bundle
- When the same power is used for SERVOPACK, as for an electric welder or electrical discharge machine or when a high-frequency noise source is present in the vicinity, use filters in the power and input circuits
- The SERVOPACK uses a switching amplifier, and electrical noise may be present in the signal line. Never leave the termination of the analog input wiring open

(4) Remedy for Radio Frequency Interference (R.F.I)

SERVOPACK may interfere with radio reception. If the controller interferes with radio reception, connect a noise filter to power supply

(5) The signal line uses cables whose core is extremely fine (0.2 to 0.3 mm²). Avoid using excessive force which may damage these cables

7. 3 3 Power Loss

The power loss of SERVOPACK is shown in Table 7 4. The values are calculated under the following conditions

- $J_L = 10 \times J_M$
- Repetitive duty of $N=0 \leftrightarrow 4000$ r/min is 5%

Table 7 4 Power Loss at Rated Output

Class	Rated Output W (HP)	SERVOPACK Type CACR-SR	Output Current A(rms)	Power Loss			Total W
				Main Circuit W	Regenerative Resistance* W	Control Circuit W	
200V	50 (0.07)	A5AC1 R A5AE1 R	0.7	20	—	30	50
	100 (0.13)	01AC1 01AE1	1.0	25	— (6)†		55 (61)†
	200 (0.27)	02AC1 02AE1	2.0	30	6		66
	300 (0.40)	03AC1 03AE1	2.7	35	6		71
	500 (0.67)	05AC1	3.6	55	6		91
	700 (0.93)	07AC1	5.7	50	15		95
100V	50 (0.07)	A5AC2 R A5AE2 R	1.2	20	—	30	50
	100 (0.13)	01AC2 R 01AE2 R	1.7	25	6		61
	200 (0.27)	02AC2 R 02AE2 R	2.9	40	6		76
	300 (0.40)	03AC2 R	3.6	50	6		86
	500 (0.67)	05AC2 R	5.5	45	15		90

* The regenerative resistor causes power loss when the power is detected. The values in the above table show maximum allowable values of average power loss. Regenerative resistor must be mounted outside if the motor is driven in a duty cycle with a larger value of resistance

† Only P series SERVOPACKS have the regenerative resistors built-in

8. DIMENSIONS

8. 1 SERVOMOTOR DIMENSIONS in mm (inches)

8 1 1 R Series AC SERVOMOTOR

If the capacity is the same, the dimensions are the same even if the voltage or pulse specifications differ (100V, 200V, 1500 pulses or 1000 pulses)

The dimension diagram show two types without brake (with key) and with brake(with key) The shaft end dimensions that are non-standard are shown for applied models The SERVOMOTOR proper is the same as shown in each diagram

(1) Standard (with key, straight shaft)

Dimensions of the keyway are based on JIS (Japanese Industrial Standard) B1031 "Sunk keys and their corresponding keyways)" Parallel key has been attached

• TYPES USAREM-A5□□2K,-01□□2K

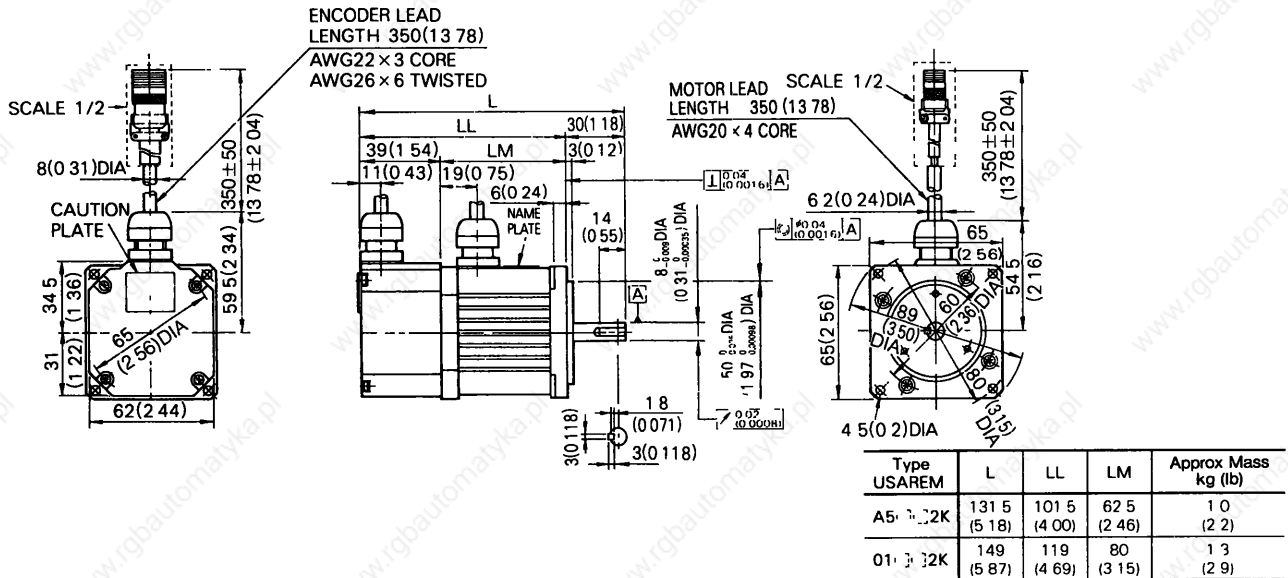

• TYPES USAREM-02□□2K, -03□□2K

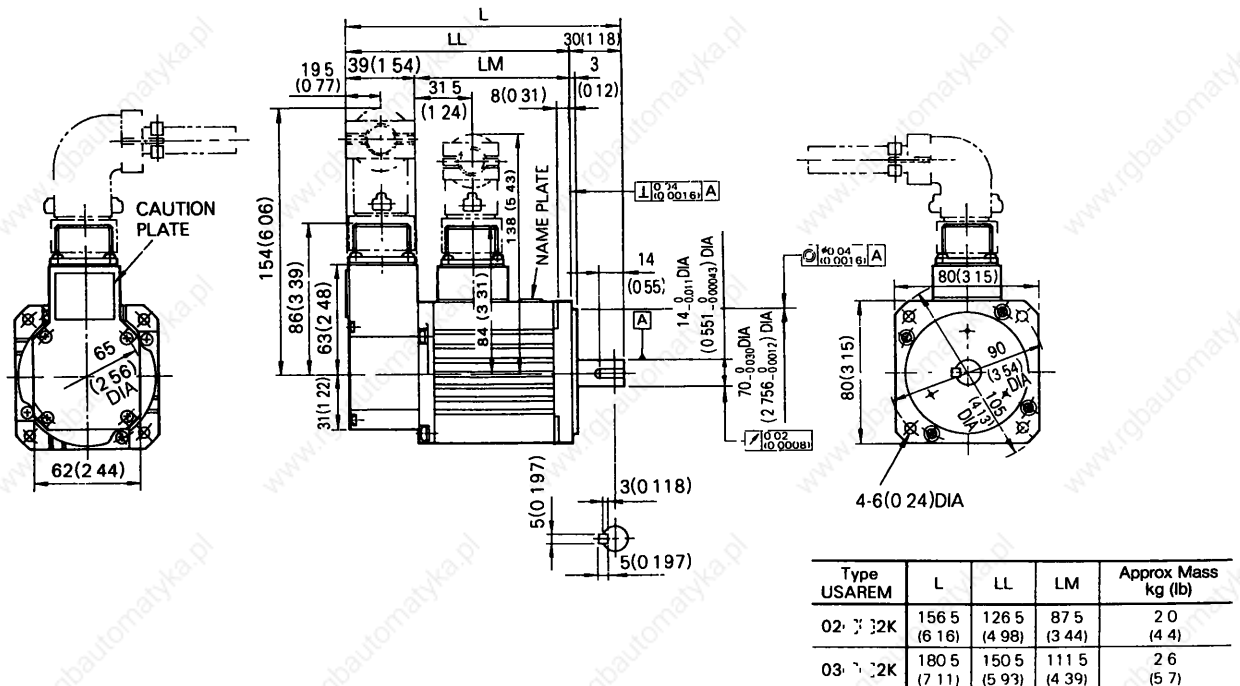

• TYPE USAREM-05 2K

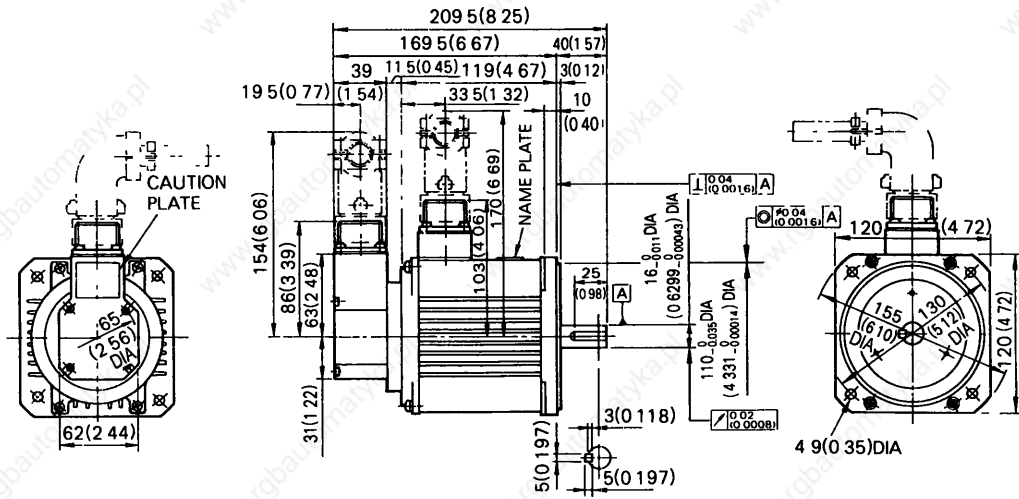

Approx Mass 4.4 kg (9.7 lb)

• TYPE USAREM-07C 2K

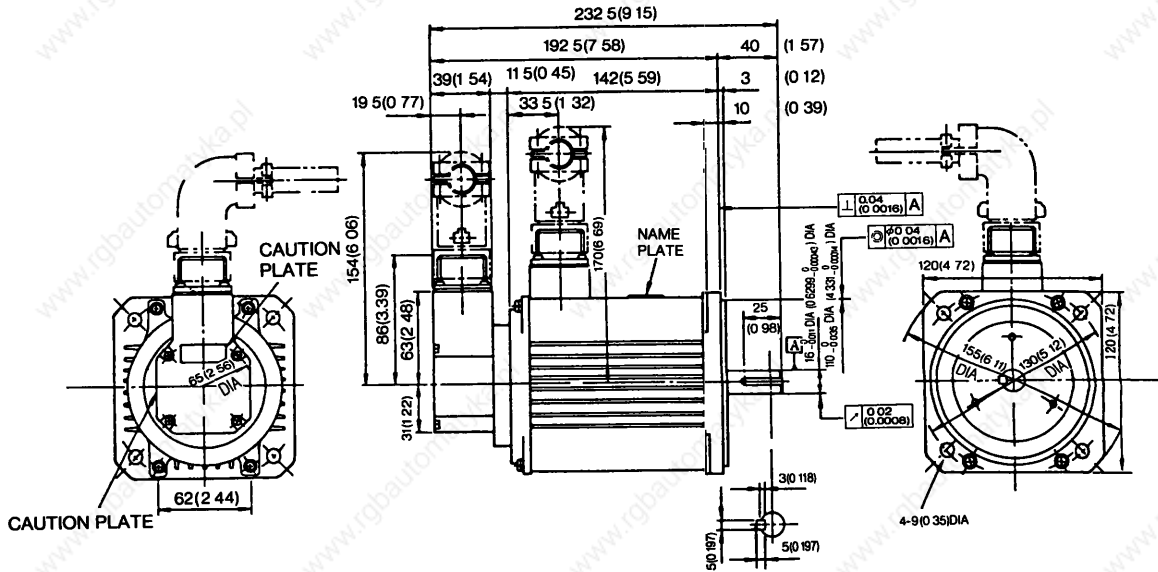

8. 1 SERVOMOTOR DIMENSIONS in mm (inches)(cont'd)

(2) With Brake (with key, straight shaft)

Dimensions of the keyway are based on JIS (Japanese Industrial Standard) B1031 "Sunk keys and their corresponding keyways)"

Parallel key has been attached

• TYPES USAREM-A5□□2KB, 01□□2KB

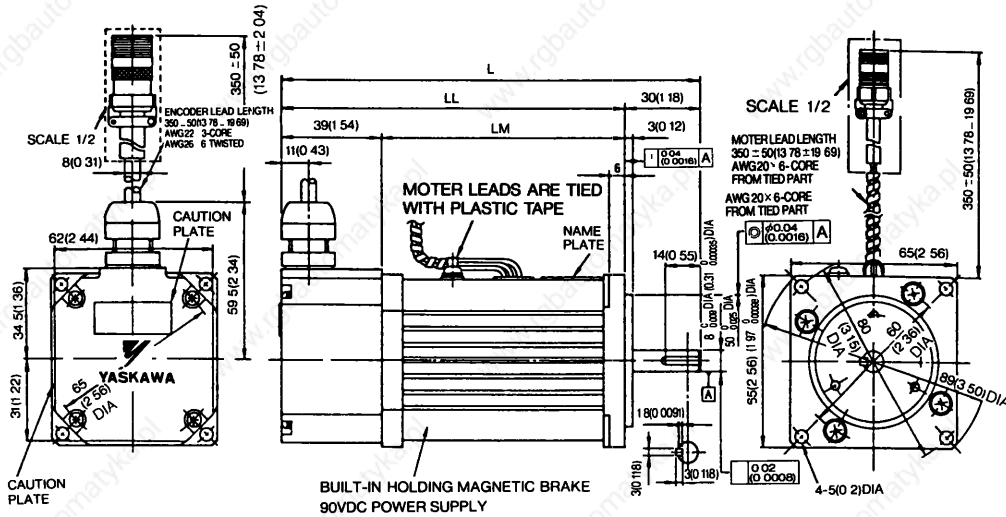

Type USAREM	Dimensions			Magnetic Brake				Approx Mass kg (lb)
	L	LL	LM	Type	Inertia g cm s ² (oz in s ² × 10 ⁻³)	Static Friction Torque kg cm (oz in)	Voltage VDC	
A5 □ □ 2KB	164.5 (6.48)	134.5 (5.30)	95.5 (3.76)	MSB/ 90-6YN	0.0528 (0.733)	6 (83.3)	90	1.4 (3.09)
01 □ □ 2KB	182 (7.17)	152 (5.99)	113 (4.45)					1.7 (3.75)

• TYPES USAREM-02□□2KB, -03□□2KB

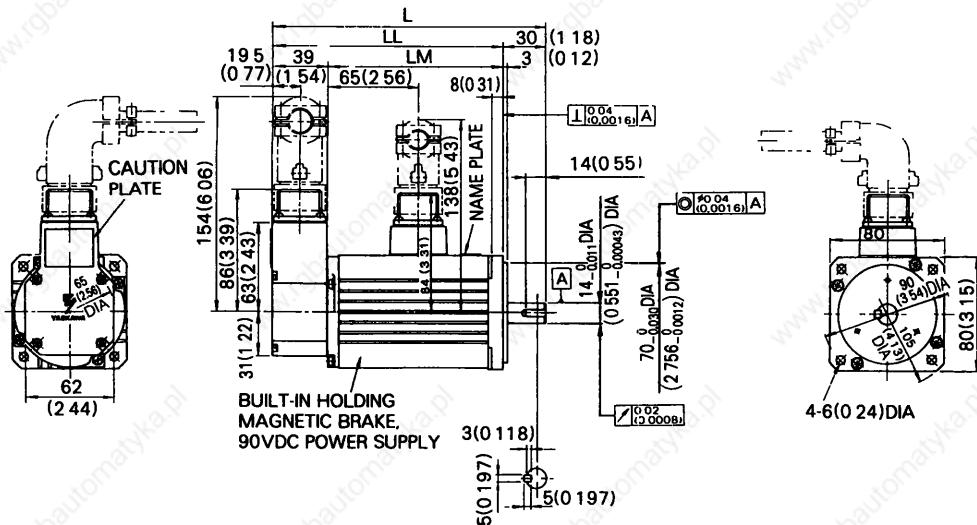

Type USAREM	Dimensions			Magnetic Brake				Approx Mass kg (lb)
	L	LL	LM	Type	Inertia g cm s ² (oz in s ² × 10 ⁻³)	Static Friction Torque kg cm (oz in)	Voltage VDC	
02 □ □ 2KB	194 (7.64)	164 (6.46)	125 (4.92)	MSB/ 90 20YN	0.1964 (2.73)	20 (2.78)	90	2.7 (5.95)
03 □ □ 2KB	218 (8.58)	188 (7.40)	149 (5.87)					3.3 (7.28)

• TYPE USAREM-05 2KB

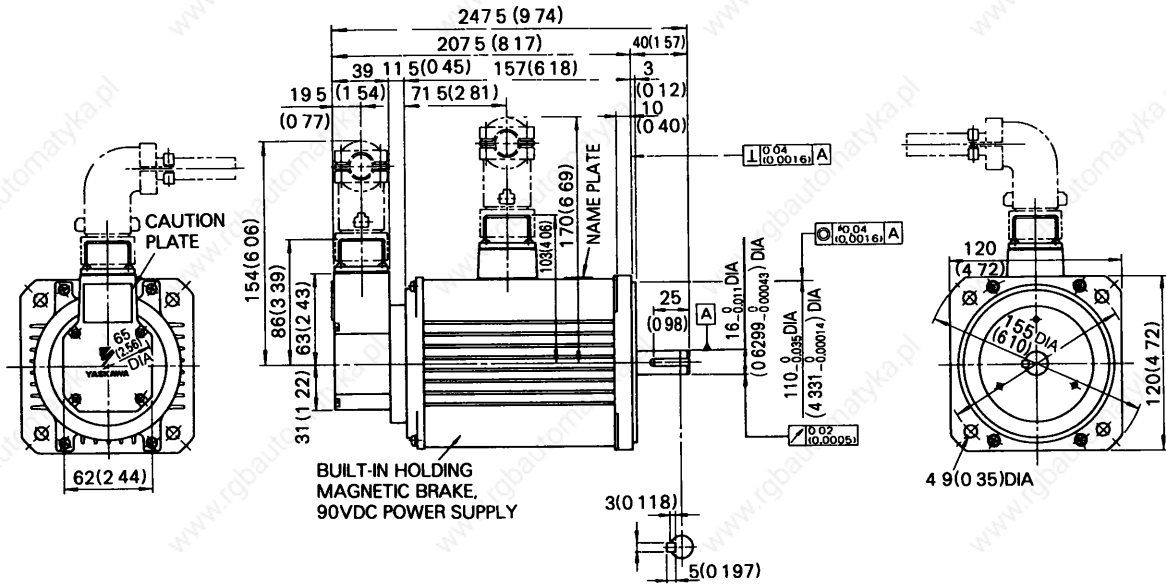

Type USAREM	Magnetic Brake				Approx Mass kg (lb)
	Type	Inertia g cm s ² (oz in s ² × 10 ⁻³)	Static Friction Torque kg cm (oz in)	Voltage VDC	
05A 2KB	MSB/ 90 30YN	0 4921 (6 83)	30 (417)	90	5 5 (12 16)

• TYPE USAREM-07C 2KB

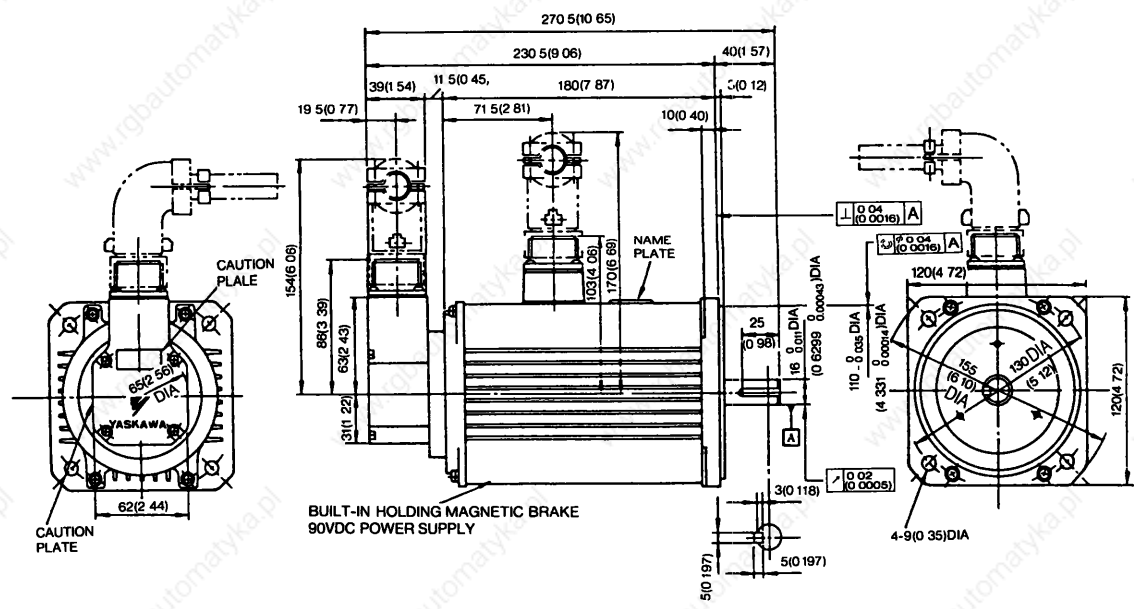

Type USAREM-	Magnetic Brake				Approx Mass kg (lb)
	Type	Inertia g · cm · s ² (oz in s ² × 10 ⁻³)	Static Friction Torque kg cm (oz in)	Voltage VDC	
05A 2KB	MSB/ 90-30YN	0 4921 (6 83)	30 (417)	90	8 1 (17 91)

(3) Shaft Extension of Straight Shaft

- TYPE USAREM-A5 $\square \square \square$ 2 to -07C $\square \square$ 2 (without brake)
- TYPE USAREM-A5 $\square \square \square$ 2B to -07C $\square \square$ 2B (with brake)

SERVOMOTOR proper is the same dimensions as standard SERVOMOTOR See Par 8 1 (1) and (2) Details of shaft extension are shown below

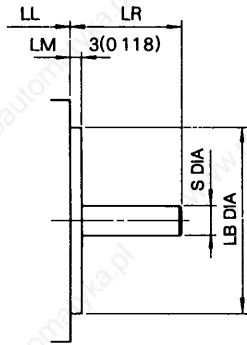

(4) Shaft Extension of Straight Shaft with Oilseal

- TYPE USAREM-A5 $\square \square \square$ 2S to -07C $\square \square$ 2S (without brake)
- TYPE USAREM-A5 $\square \square \square$ 2SB to -07C $\square \square$ 2SB (with brake)

SERVOMOTOR proper is the same dimensions as standard SERVOMOTOR See Par 8 1 (1) and (2) Details of shaft extension are shown below

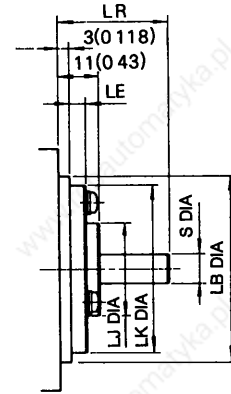

Without Brake Type USAREM	With Brake Type USAREM	LR	S	LB
A5 $\square \square \square$ 2	A5 $\square \square \square$ 2B	30 (1 18)	8 $\begin{smallmatrix} 0 \\ -0.009 \\ 0 \\ -0.0035 \end{smallmatrix}$	50 $\begin{smallmatrix} 0 \\ -0.025 \\ 0 \\ -0.00098 \end{smallmatrix}$
01 $\square \square \square$ 2	01 $\square \square \square$ 2B		14 $\begin{smallmatrix} 0 \\ -0.0 \\ 0 \\ -0.00043 \end{smallmatrix}$	70 $\begin{smallmatrix} 0 \\ -0.030 \\ 0 \\ -0.0012 \end{smallmatrix}$
02 $\square \square \square$ 2	02 $\square \square \square$ 2B		16 $\begin{smallmatrix} 0 \\ -0.001 \\ 0 \\ -0.0003 \end{smallmatrix}$	110 $\begin{smallmatrix} 0 \\ -0.035 \\ 0 \\ -0.0014 \end{smallmatrix}$
03 $\square \square \square$ 2	03 $\square \square \square$ 2B	40 (1 57)	16 $\begin{smallmatrix} 0 \\ -0.001 \\ 0 \\ -0.0003 \end{smallmatrix}$	110 $\begin{smallmatrix} 0 \\ -0.035 \\ 0 \\ -0.0014 \end{smallmatrix}$
05 $\square \square \square$ 2	05 $\square \square \square$ 2B		16 $\begin{smallmatrix} 0 \\ -0.001 \\ 0 \\ -0.0003 \end{smallmatrix}$	110 $\begin{smallmatrix} 0 \\ -0.035 \\ 0 \\ -0.0014 \end{smallmatrix}$
07C $\square \square \square$ 2	07C $\square \square \square$ 2B		16 $\begin{smallmatrix} 0 \\ -0.001 \\ 0 \\ -0.0003 \end{smallmatrix}$	110 $\begin{smallmatrix} 0 \\ -0.035 \\ 0 \\ -0.0014 \end{smallmatrix}$

Without Brake Type USAREM	With Brake Type USAREM	LR	LE	LJ	LK	S	LB	Shaft* Seal
A5 $\square \square \square$ 2S	A5 $\square \square \square$ 2SB	30 (1 18)	45 (0 18)	25	45	8 $\begin{smallmatrix} 0 \\ 0.009 \\ 0 \\ -0.00035 \end{smallmatrix}$	50 $\begin{smallmatrix} 0 \\ -0.025 \\ 0 \\ -0.00098 \end{smallmatrix}$	SB08187
01 $\square \square \square$ 2S	01 $\square \square \square$ 2SB			36	60	14 $\begin{smallmatrix} 0 \\ -0.011 \\ 0 \\ -0.00043 \end{smallmatrix}$	70 $\begin{smallmatrix} 0 \\ -0.030 \\ 0 \\ -0.0012 \end{smallmatrix}$	SB14287
02 $\square \square \square$ 2S	02 $\square \square \square$ 2SB			36	60	14 $\begin{smallmatrix} 0 \\ -0.011 \\ 0 \\ -0.00043 \end{smallmatrix}$	70 $\begin{smallmatrix} 0 \\ -0.030 \\ 0 \\ -0.0012 \end{smallmatrix}$	SB14287
03 $\square \square \square$ 2S	03 $\square \square \square$ 2SB	40 (1 57)	25 (0 10)	50 (1 97)	73 (2 87)	16 $\begin{smallmatrix} 0 \\ -0.001 \\ 0 \\ -0.0003 \end{smallmatrix}$	110 $\begin{smallmatrix} 0 \\ -0.035 \\ 0 \\ -0.0014 \end{smallmatrix}$	SB16307
05 $\square \square \square$ 2S	05 $\square \square \square$ 2SB					16 $\begin{smallmatrix} 0 \\ -0.001 \\ 0 \\ -0.0003 \end{smallmatrix}$	110 $\begin{smallmatrix} 0 \\ -0.035 \\ 0 \\ -0.0014 \end{smallmatrix}$	
07C $\square \square \square$ 2S	07C $\square \square \square$ 2SB					16 $\begin{smallmatrix} 0 \\ -0.001 \\ 0 \\ -0.0003 \end{smallmatrix}$	110 $\begin{smallmatrix} 0 \\ -0.035 \\ 0 \\ -0.0014 \end{smallmatrix}$	

* Nippon Oil Seal Industry Co Ltd

(5) Shaft Extension of Straight Shaft with Keyway and Shaft Seal

SERVOMOTOR proper and shaft extension are same dimensions as standard SERVOMOTOR See Par 8 1 (1) and (2) Shaft seal is same dimensions as shown in Par 8 1 (4)

8 1 2 P Series AC SERVOMOTOR

If the capacity is the same, the dimensions are the same even if the voltage or pulse specifications differ (100V, 200V, 1500 pulses or 1000 pulses)

The dimension diagrams show two types, without brake (with key) and with brake (with key) The shaft end dimensions that are non-standard are shown for applied models The SERVOMOTOR proper is the same as shown in each diagram

(1) Standard (with key, straight shaft)

Dimensions of the keyway are based on JIS (Japanese Industrial Standard) B1031 "Sunk keys and their corresponding keyways" Parallel key has been attached

- TYPES USAPEM-01 2 K
- 02 2 K
- 03 2 K

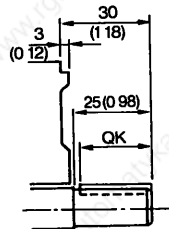
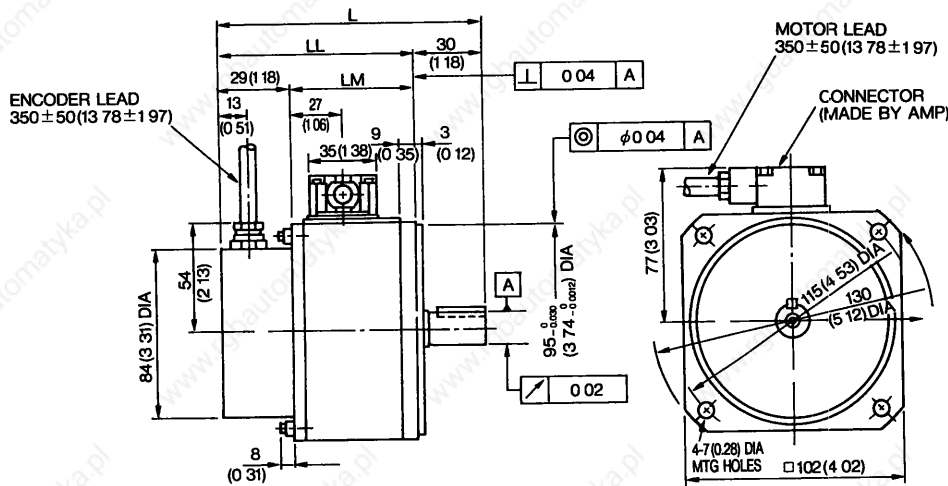

Detail of Shaft Extension

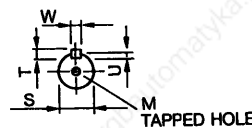

Type USAPEM-	L	LL	LM	Shaft Extension						Approx Mass kg (lb)
				S	QK	U	W	T	M	
01 CE 2 K	115 (4 53)	85 (3 35)	56 (2 20)	$11_{-0.011}^{0.000}$ (0 433-0 00043)	18 (0 71)	2 5 (0 10)	4 (0 16)	4 (0 16)	M3, Deep 6 (0 24)	1 7(3 7)
02 CE 2 K	118 (4 65)	88 (3 46)	59 (2 32)	$14_{-0.011}^{0.000}$ (0 551-0 00043)	18 (0 71)	3 (0 12)	5 (0 20)	5 (0 20)	M4, Deep 10 (0 39)	2 0(4 4)
03 CE 2 K	122 (4 41)	92 (3 62)	63 (2 48)							2 3(5 1)

- TYPES USAPEM-05 \square 2 K
- 07 \square 2 K

Detail of Shaft Extension

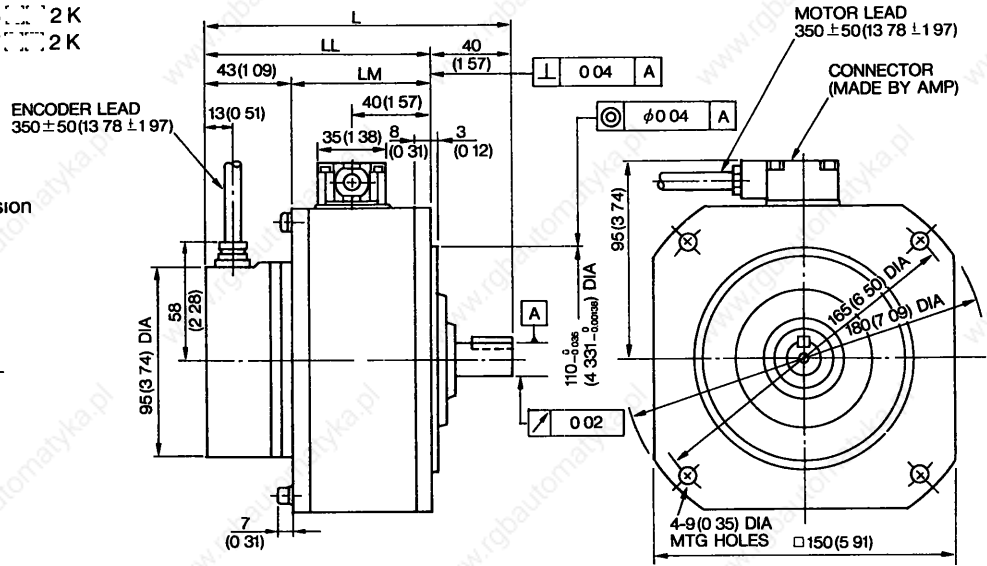
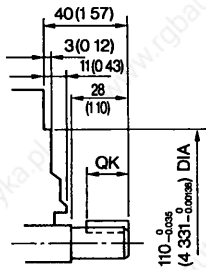

Type USAPEM-	L	LL	LM	Shaft Extension						Approx Mass kg (lb)
				S	QK	U	W	T	M	
05 CE 2 K	152 (5.98)	112 (4.41)	69 (2.72)	16.0 ^{-0.011} (0.630-0.00043)	20 (0.79)	3 (0.12)	5 (0.197)	5 (0.197)	M4, Deep 10 (0.39)	4.6 (10.1)
07 CE 2 K	152 (5.98)	112 (4.41)	69 (2.72)	16.0 ^{-0.011} (0.630-0.00043)	20 (0.79)	3 (0.12)	5 (0.197)	5 (0.197)	M4, Deep 10 (0.39)	5 (11.0)

(2) With Brake (with key, straight shaft)

Dimensions of the keyway are based on JIS (Japanese Industrial Standard) B1031 "Sunk keys and their corresponding keyways"

Parallel key has been attached

- TYPES USAPEM -01 \square 2KB
- 02 \square 2KB
- 03 \square 2KB

Detail of Shaft Extension

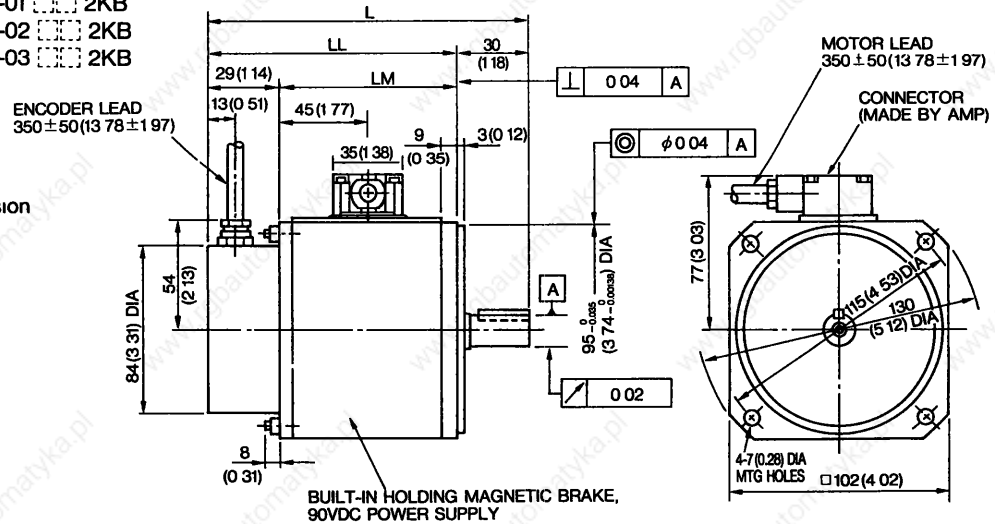
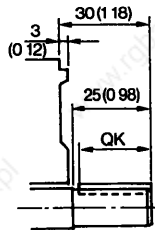

Type USAPEM-	L	LL	LM	Shaft Extension						Approx Mass kg (lb)
				S	QK	U	W	T	M	
01 CE 2 KB	141 (5.55)	111 (4.37)	82 (3.23)	11.0 ^{-0.011} (0.43-0.00043)	18 (0.71)	2.5 (0.10)	4 (0.16)	4 (0.16)	M3, Deep 6 (0.24)	2.7 (5.95)
02 CE 2 KB	144 (5.67)	114 (4.49)	85 (3.35)	14.0 ^{-0.011} (0.55-0.00043)	18 (0.71)	3 (0.12)	5 (0.20)	5 (0.20)	M4, Deep 10 (0.39)	3.0 (6.61)
03 CE 2 KB	148 (5.83)	118 (4.65)	89 (3.50)							3.3 (7.28)

• TYPES USAPEM -05 \square 2KB

-07 \square 2KB

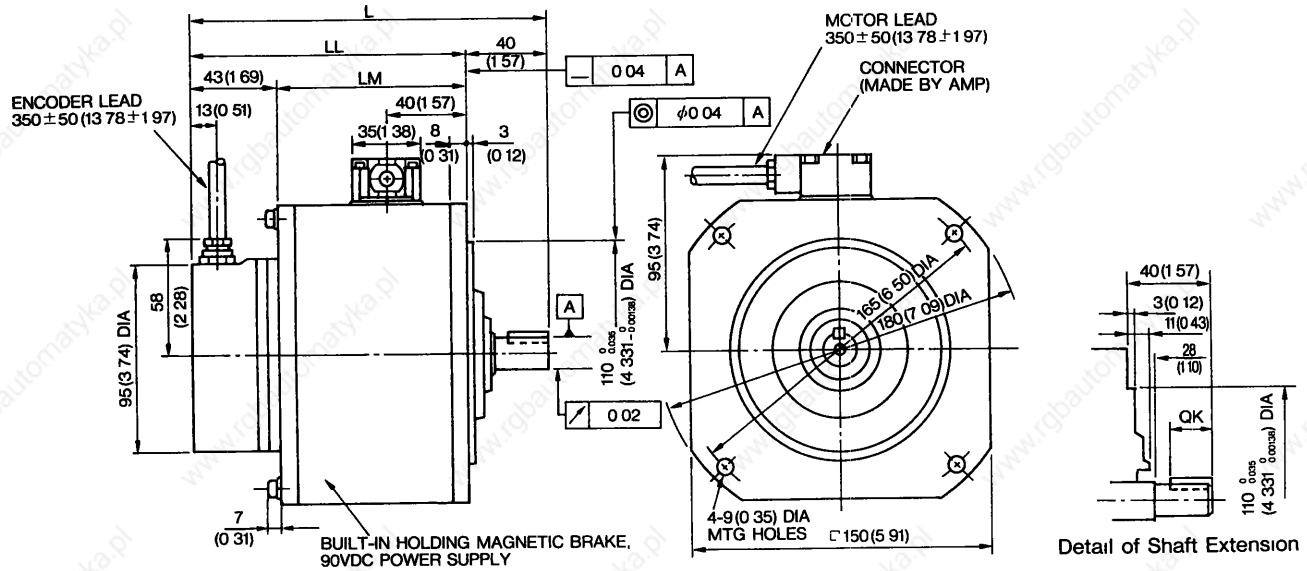

Type USAPEM-	L	LL	LM	Shaft Extension						Approx Mass kg (lb)
				S	QK	U	W	T	M	
05 CE 2 KB	178 (7 01)	138 (5 43)	95 (3 74)	$16 \frac{0}{0.011}$ (0 63 $\frac{0}{0.00043}$)	20 (0 79)	3 (0 12)	5 (0 20)	5 (0 20)	M4, Deep 10 (0 39)	6 6(14 6)
07 CE 2 KB	178 (7 01)	138 (5 43)	95 (3 74)	$16 \frac{0}{0.011}$ (0 63 $\frac{0}{0.00043}$)	20 (0 79)	3 (0 12)	5 (0 20)	5 (0 20)	M4, Deep 10 (0 39)	7(15 4)

8. 2 SERVOPACK DIMENSIONS in mm (inches)

8 2 1 Types CACR-SR [] AC

(1) 200V

· TYPES CACR-SRA5AC1 [] R, -SR01AC1 []

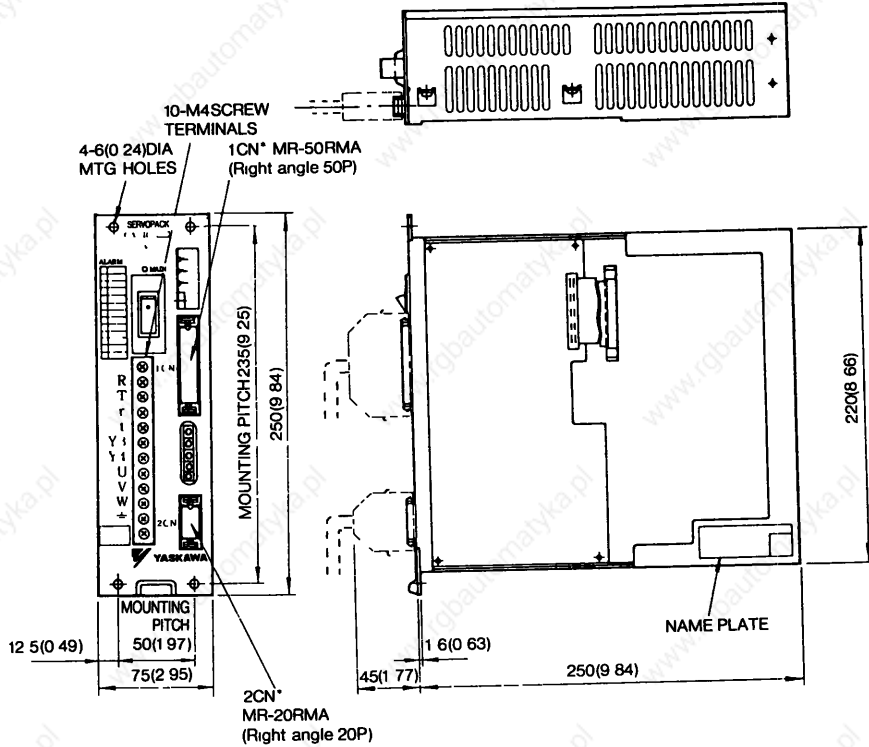

*Made by Honda Tushin Co.,Ltd

Connector Symbol	Attachments		
	Manufacturer	Receptacle Type	Case Type
1 CN	Honda Tsushin Co Ltd	MR-50F	MR-50L
2 CN		MR-20F	MR-20L

· TYPES CACR-SR02AC1 [] , -SR03AC1 []

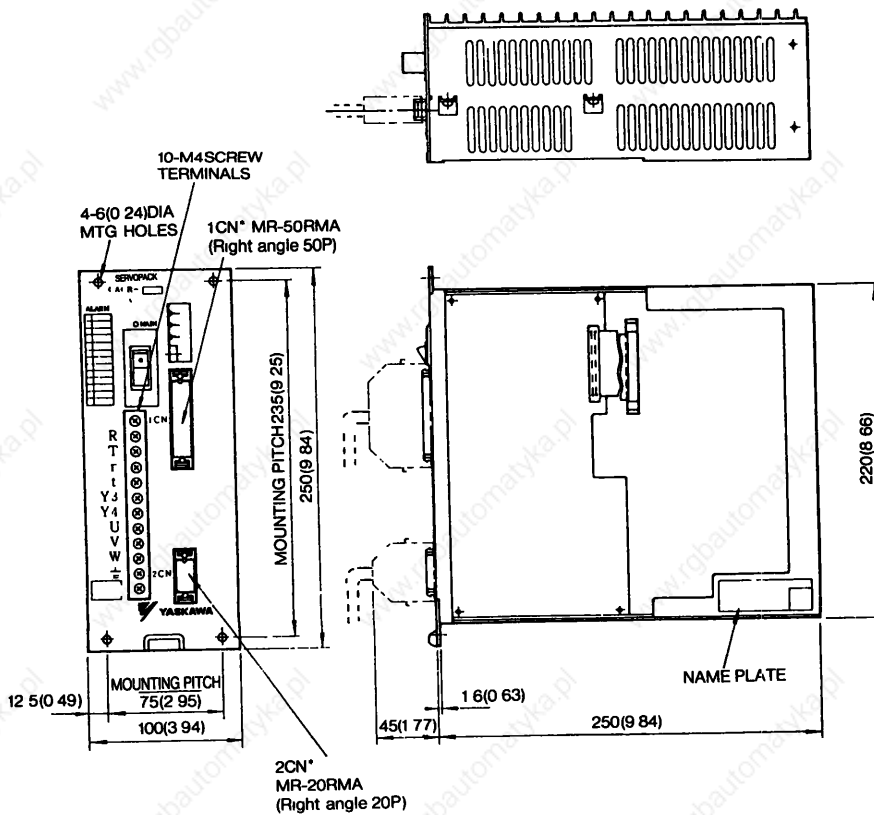

*Made by Honda Tushin Co.,Ltd

Connector Symbol	Attachments		
	Manufacturer	Receptacle Type	Case Type
1 CN	Honda Tsushin Co Ltd	MR-50F	MR-50L
2 CN		MR-20F	MR-20L

• TYPES CACR-SR05AC1

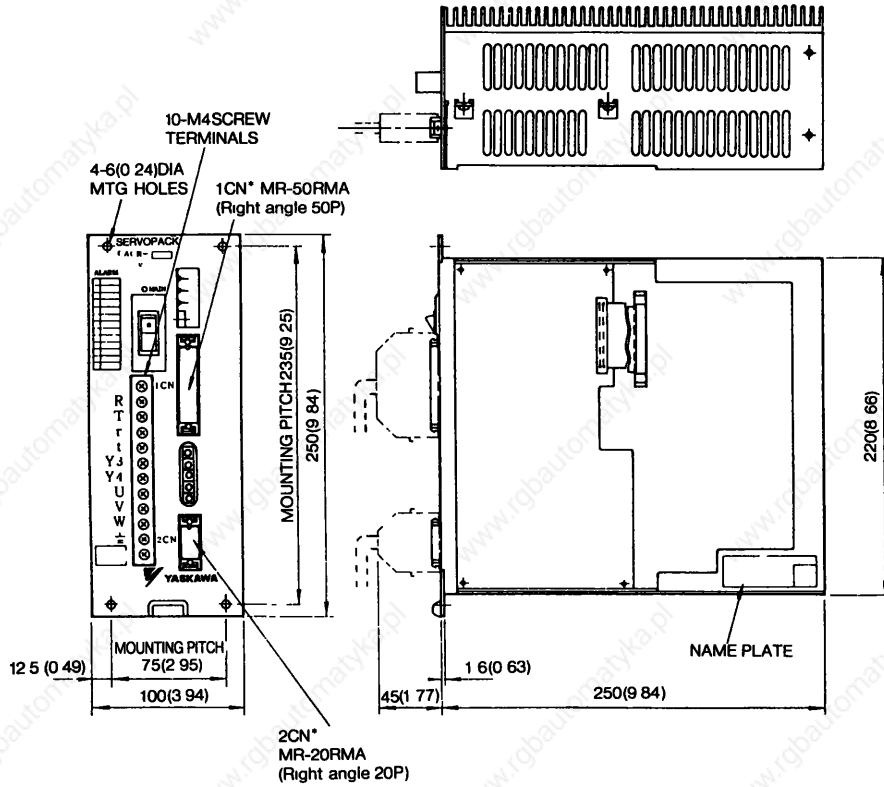

*Made by Honda Tushin Co.,Ltd

Connector Symbol	Attachments		
	Manufacturer	Receptacle Type	Case Type
1 CN	Honda Tsushin Co Ltd	MR 50F	MR-50L
2 CN	Honda Tsushin Co Ltd	MR 20F	MR 20L

• TYPES CACR-SR07AC1

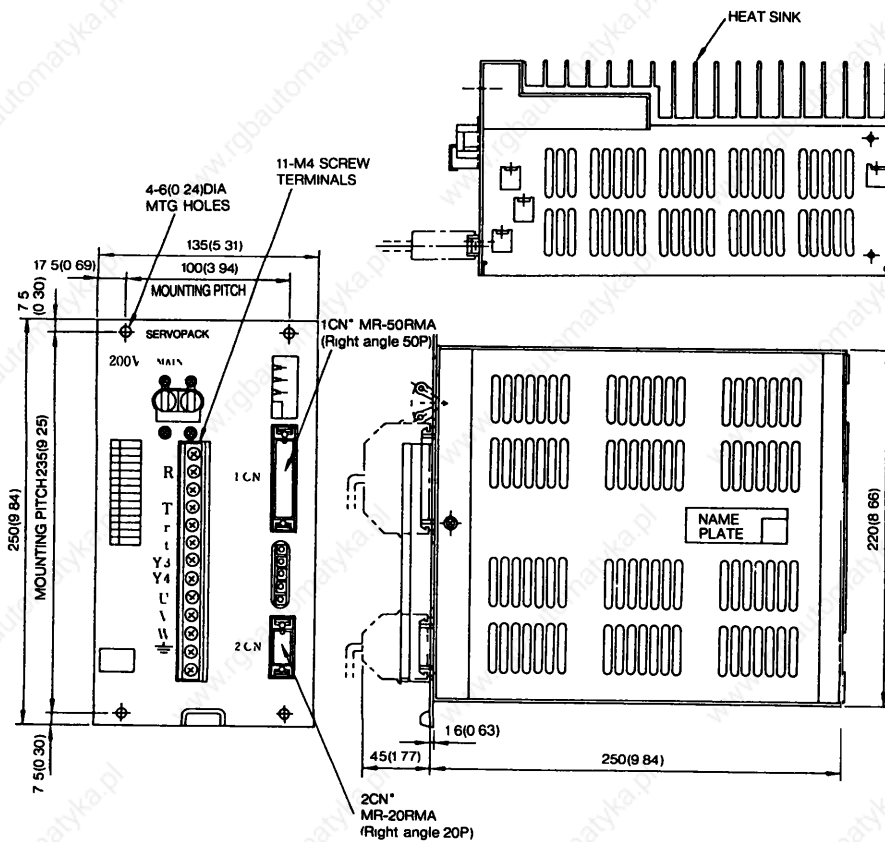

*Made by Honda Tushin Co.,Ltd

Connector Symbol	Attachments		
	Manufacturer	Receptacle Type	Case Type
1 CN	Honda Tsushin Co Ltd	MR-50F	MR-50L
2 CN	Honda Tsushin Co Ltd	MR-20F	MR-20L

(2) 100V

• TYPE CACR-SRA5AC2 R

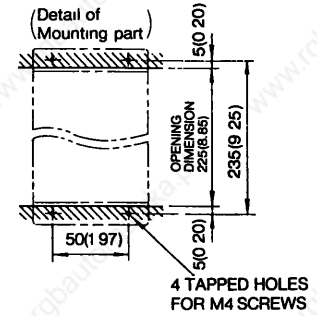
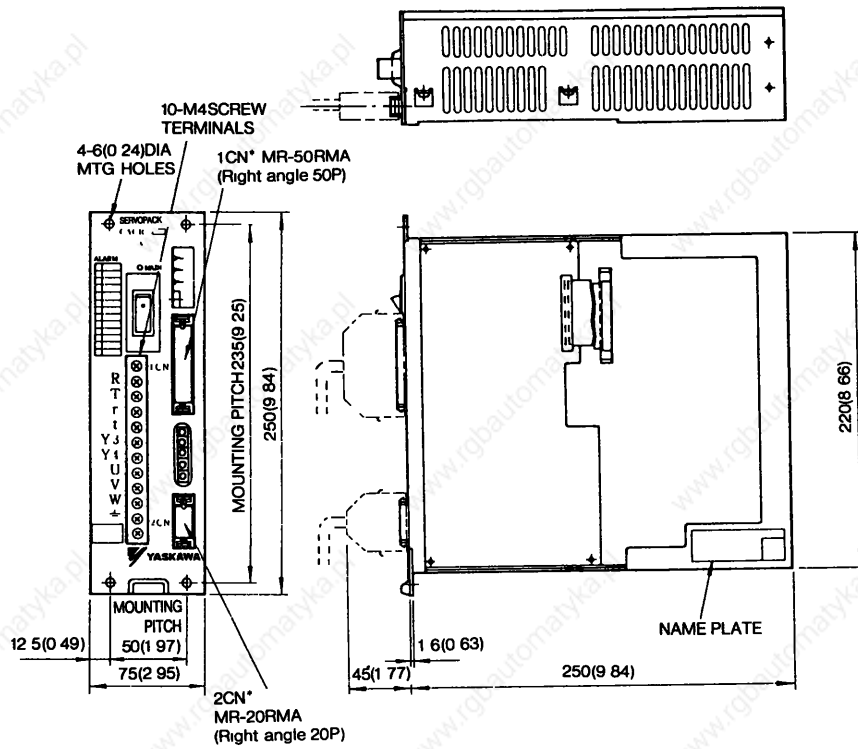

*Made by Honda Tsushin Co.Ltd

Connector Symbol	Attachments		
	Manufacturer	Receptacle Type	Case Type
1CN	Honda Tsushin Co.Ltd	MR 50F	MR-50L
2CN		MR-20F	MR 20L

• TYPE CACR-SR01AC2 R,-02AC2 R

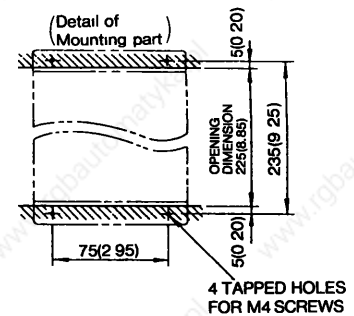
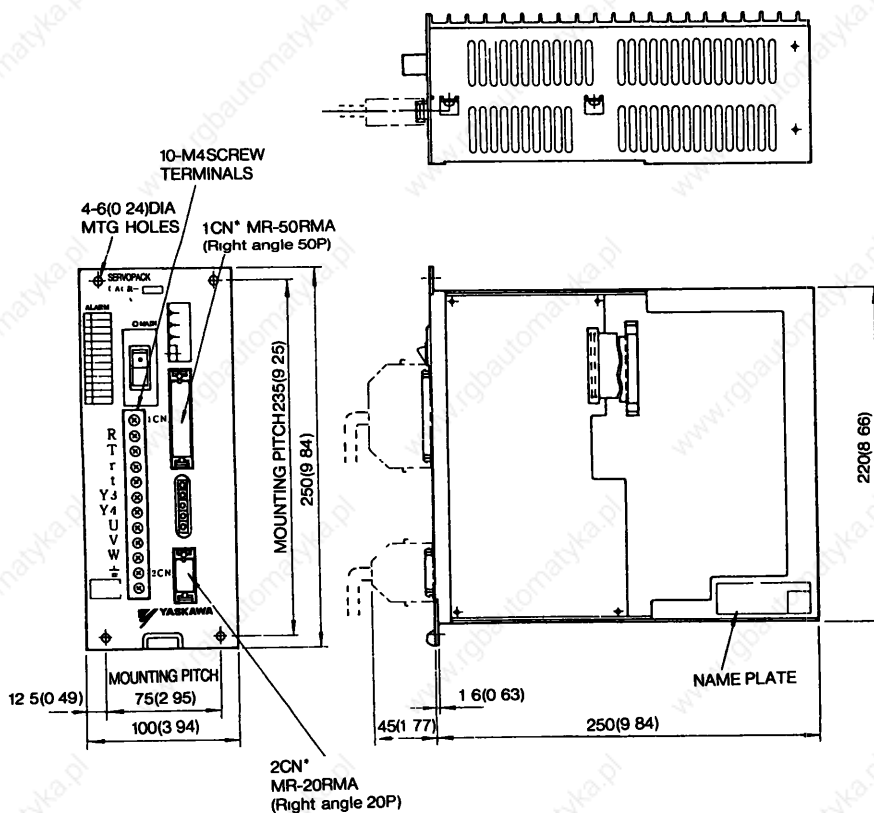

*Made by Honda Tsushin Co.,Ltd

Connector Symbol	Attachments		
	Manufacturer	Receptacle Type	Case Type
1CN	Honda Tsushin Co.Ltd	MR 50F	MR 50L
2CN		MR 20F	MR-20L

TYPE CACR-SR03AC2 R

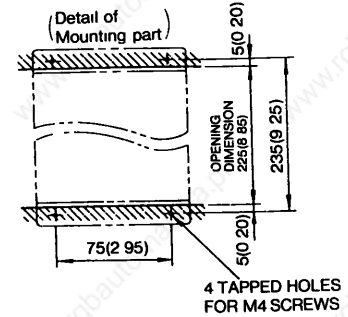
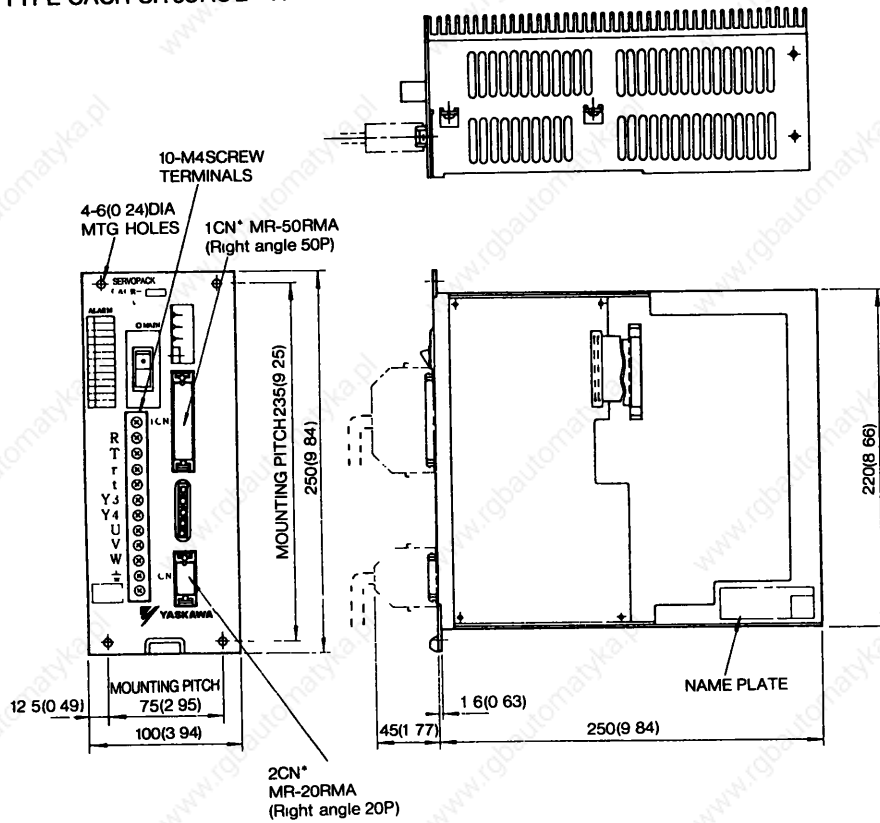

*Made by Honda Tushin Co.,Ltd

Connector Symbol	Attachments		
	Manufacturer	Receptacle Type	Case Type
1 CN	Honda Tsushin Co Ltd	MR-50F	MR 50L
2 CN	Honda Tsushin Co Ltd	MR 20F	MR 20L

TYPE CACR-SR05AC2 R

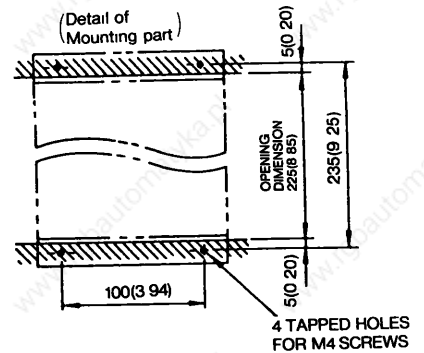
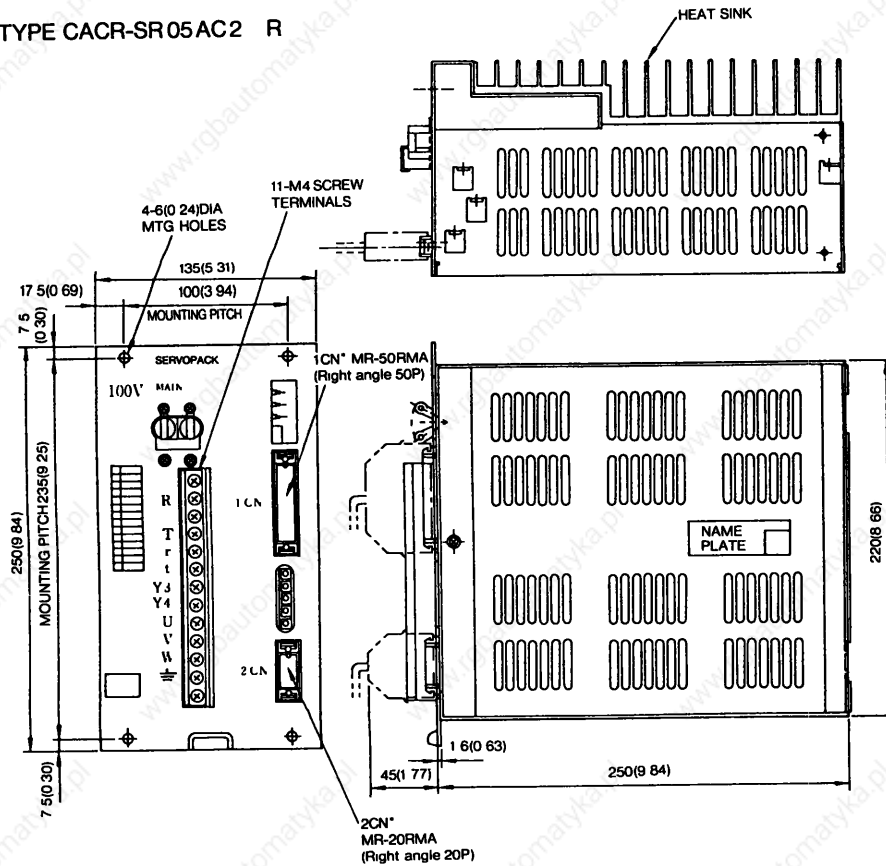

*Made by Honda Tushin Co.,Ltd

Connector Symbol	Attachments		
	Manufacturer	Receptacle Type	Case Type
1 CN	Honda Tsushin Co Ltd	MR 50F	MR 50L
2 CN	Honda Tsushin Co Ltd	MR-20F	MR 20L

8 2 2 Types CACR-SR [] AE

(1) 200 V

• TYPES CACR-SRA5 to -03AE1 []

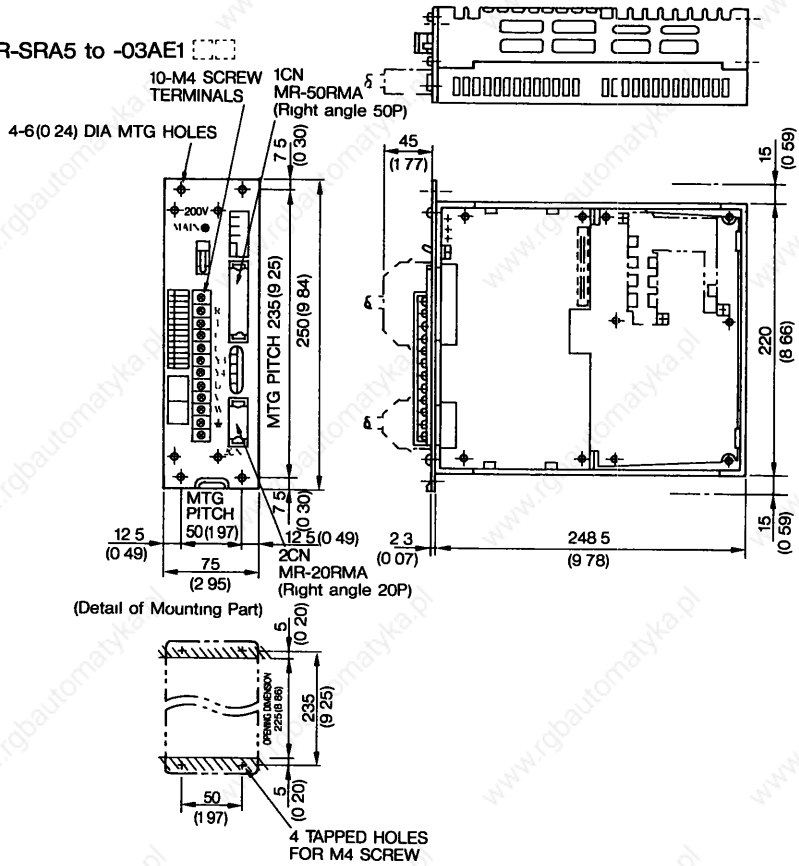

*Made by Honda Tushin Co.,Ltd

Connector Symbol	Attachments		
	Manufacturer	Receptacle Type	Case Type
1 CN	Honda Tsushin Co Ltd	MR-50F	MR-50L
2 CN	Honda Tsushin Co Ltd	MR-20F	MR-20L

(2) 100 V

• TYPES CACR-SRA5 to -02AE2 [] R

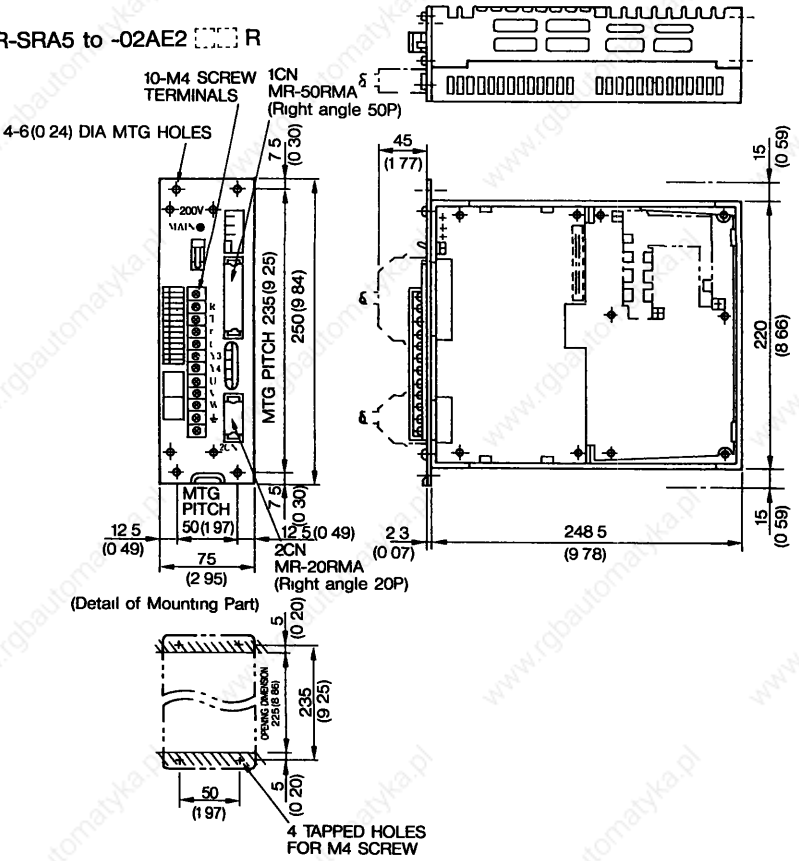

*Made by Honda Tushin Co.,Ltd

Connector Symbol	Attachments		
	Manufacturer	Receptacle Type	Case Type
1 CN	Honda Tsushin Co Ltd	MR-50F	MR-50L
2 CN	Honda Tsushin Co Ltd	MR-20F	MR-20L

8. 3 PERIPHERAL EQUIPMENT in mm (inches)

(1) Variable Resistor for Speed Setting Type 25HP-10B

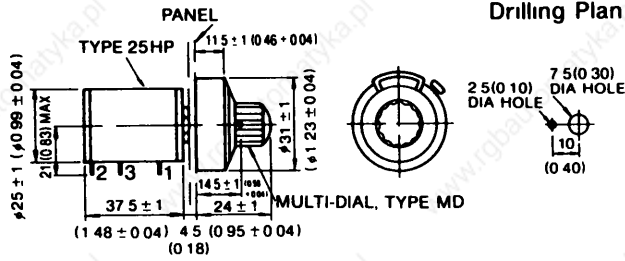

AC Input Side		Brake Side
100V	200V	
Blue	Yellow	Red
White	White	Black

- Lead length each 500 mm (19.69 inches)
- Lead color

• Max ambient temp 60°C

• AC 100V internal circuit

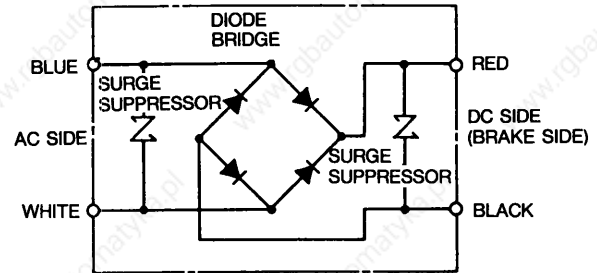

(2) Power Supply for Brake

According to the motor select 100V/200V power supply for brake

- Input 100 VAC, 90 VDC (DP8401002-2)
- Input 200 VAC, 90 VDC (DP8401002-1)

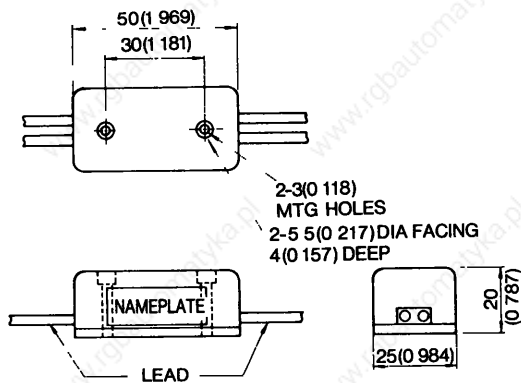

• AC 200V internal circuit

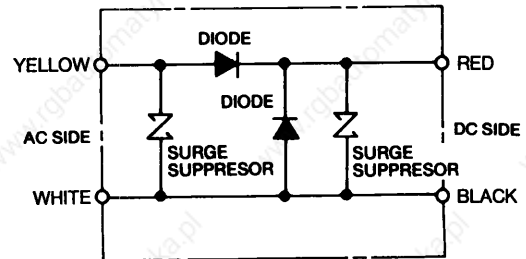

Note

Open / close of brake power supply circuit is possible at AC and DC sides. Normally safety operation is more available at AC side. If the circuit is opened / closed at DC side, provide surge suppressor near brake coil otherwise the brake coil might be destroyed.

9. TEST RUN

Before test run, check the following Correct any deficiency

9.1 CHECK ITEMS BEFORE TEST RUN

9.1.1 SERVOMOTOR

Before test run, check the following If the test run is performed after long storage, see par 11 Inspection and Maintenance

- Connection to machines or devices, wiring, fuse connection, and grounding are correct
- Bolts and nuts are not loose
- For motors with oil seals, the seals are not damaged and oil is properly lubricated

9.1.2 SERVOPACK

- Setting switches are correctly set to satisfy the specifications for the applicable SERVOMOTOR and optical encoder.
- Connection and wiring leads are firmly connected to terminals or inserted into the connectors
- The power supply is turned OFF if servo alarm occurs
- Voltage supplied to SERVOPACK is 200 to 230V $\pm 10\%$ or 115V $\pm 15\%$
- The speed reference should be 0 V

9.2 TEST RUN PROCEDURES

9.2.1 Preparation of Test Run Operation

During test run, loads should not be applied to the SERVOMOTOR If it is necessary to start with the driven machine connected to the motor, confirm that the driven system has been ready for emergency stop at any time

- Power ON

After checking items in par 9.1, turn ON the power supply When the power ON sequence is correct, according to Par 6.1, the power is turned ON by depressing the POWER push-button for approximately 1 second

- When the power is correctly supplied, the following green **LED** s light. **P** and **MP** .

- When a Servo ON signal is input (contact is on), the power circuit in the SERVOPACK operates and the motor is ready to run

9.2.2 Test Run Operation

The operation is possible only while Servo ON signal is ON

- Increase the speed reference voltage gradually from 0 V, then the motor will rotate at a speed proportional to the reference voltage
- When the reference voltage is positive, the motor rotates forward (counterclockwise rotation when viewed from drive end-output shaft) (Fig. 9.1)

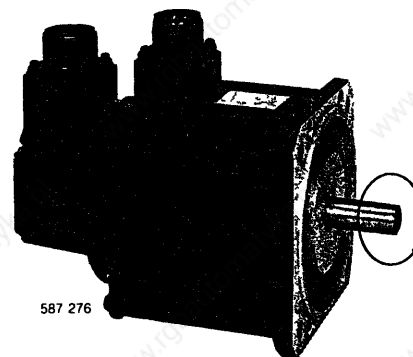

Fig 9.1 Motor Forward Running

9.2.3 Inspection during Test Run

The following items should be checked during the test run

- Unusual vibration
- Abnormal noise
- Excessive temperature rise

If any abnormality is found, take corrective actions according to par 12 At a test operation, the load and machine may not fit well at first and result in overload

10. ADJUSTMENT

10.1 SETTING AT THE TIME OF DELIVERY

The SERVOPACK has been factory-adjusted as follows

(1) R Series

Table 10 1 Standard Adjustmt and Setting Specifications

Class	Rated Output W (HP)	SERVOPACK Type CACR-	Applicable SERVOMOTOR			SERVOPACK Adjustment		
			Type USAREM	Optical Encoder Pulses/rev	Rated Current \pm ADC	Speed Setting	Starting Current Setting \pm A	PG Frequency Dividing Ratio
200V	50 (0 07)	SRA5AC1 ER	A5CE2	1500	0 7	3000r/min at rated speed reference	2 1	x1
		SRA5AE1 ER						
		SRA5AC1 FR	A5CF2	1000				
		SRA5AE1 FR						
	100 (0 13)	SR01 AC1 ER	01CE2	1500	1 0			
		SR01 AE1 ER						
		SR01 AC1 FR	01CF2	1000				
		SR01 AE1 FR						
	200 (0 27)	SR02AC1 ER	02CE2	1500	2 0			
		SR02AE1 ER						
		SR02AC1 FR	02CF2	1000				
		SR02AE1 FR						
	300 (0 40)	SR03AC1 ER	03CE2	1500	2 7			
		SR03AE1 ER						
		SR03AC1 FR	03CF2	1000				
		SR03AE1 FR						
	500 (0 67)	SR05AC1 ER	05CE2	1500	3 6			
		SR05AE1 ER						
SR05AC1 FR		05CF2	1000					
SR05AE1 FR								
700 (0.93)	SR07AC1 ER	07CE2	1500	5 7				
	SR07AE1 ER							
	SR07AC1 FR	07CF2	1000					
	SR07AE1 FR							
100V	50 (0 07)	SRA5AC2ER	A5DE2	1500	1 2			
		SRA5AE2ER						
		SRA5AC2FR	A5DF2	1000				
		SRA5AE2FR						
	100 (0 13)	SR01 AC2ER	01DE2	1500	1 7			
		SR01 AE2ER						
		SR01 AC2FR	01DF2	1000				
		SR01 AE2FR						
	200 (0.27)	SR02AC2ER	02DE2	1500	2 9			
		SR02AE2ER						
		SR02AC2FR	02DF2	1000				
		SR02AE2FR						
	300 (0 40)	SR03AC2ER	03DE2	1500	3 6			
		SR03AE2ER						
		SR03AC2FR	03DF2	1000				
		SR03AE2FR						
	500 (0 67)	SR05AC2ER	05DE2	1500	5 5			
		SR05AE2ER						
SR05AC2FR		05DF2	1000					
SR05AE2FR								

Table 10 2 Standard Factory-adjusted Switch Settings

SERVOPACK			SW1 (16P Setting Switch)	SW2 (Hexadecimal Digital Switch)	SEL1	SEL2	SEL3	SEL4
Class	Rated Output W (HP)	Type CACR-	Optical Encoder Pulse Setting	Dividing Ratio Setting	f/V Filter Time Constant Setting	Mood Switch (MS) Level Setting	MS/P/PI Selection	Test Mode
Standard	200 V	50 (0.07)	SRA5AC1ER	1500p/rev	1/1 "0"	0.6ms 1 2 3	200% 1 2 3	MS Selection 1 2 3
			SRA5AE1ER					
		100 (0.13)	SR01AC1ER					
			SR01AE1ER					
		200 (0.27)	SR02AC1ER					
			SR02AE1ER					
		300 (0.40)	SR03AC1ER					
		SR03AE1ER						
	500 (0.67)	SR05AC1ER						
		SR05AE1ER						
	700 (0.93)	SR07AC1ER						
		SR07AE1ER						
	100 V	50 (0.07)	SRA5AC2ER					
			SRA5AE2ER					
100 (0.13)		SR01AC2ER						
		SR01AE2ER						
200 (0.27)		SR02AC2ER						
		SR02AE2ER						
300 (0.40)		SR03AC2ER						
	SR03AE2ER							
500 (0.67)	SR05AC2ER							
	SR05AE2ER							
Optional	200 V	50 (0.07)	SRA5AC1FR	1000p/rev	1/1 "0"	0.6ms 1 2 3	200% 1 2 3	MS Selection 1 2 3
			SRA5AE1FR					
		100 (0.13)	SR01AC1FR					
			SR01AE1FR					
		200 (0.27)	SR02AC1FR					
			SR02AE1FR					
		300 (0.40)	SR03AC1FR					
		SR03AE1FR						
	500 (0.67)	SR05AC1FR						
		SR05AE1FR						
	700 (0.93)	SR07AC1FR						
		SR07AE1FR						
	100 V	50 (0.07)	SRA5AC2FR					
			SRA5AE2FR					
100 (0.13)		SR01AC2FR						
		SR01AE2FR						
200 (0.27)		SR02AC2FR						
		SR02AE2FR						
300 (0.40)		SR03AC2FR						
	SR03AE2FR							
500 (0.67)	SR05AC2FR							
	SR05AE2FR							

● Short-circuited ○ Open

Table 10 3 Standard Factory-adjusted Potentiometer Setting

SERVOPACK		VR1	IN-B	VR3	ZERO	VR5	CUR	VR6	LOOP	VR8	P-GAIN
Class	SERVOPACK Type CACR-	Auxiliary Input Setting		Zero Drift Setting		Max Current Setting		Loop Gain Setting		Proportional Gain	
200 V	50 (0 07)	SRA5AC1 R	10V/rated speed (For user adjustment)	4 to 6/10	10/10 max	5/10	5/10				
		SRA5AE1 R									
	100 (0 13)	SR01AC1 R									
		SR01AE1 R									
	200 (0 27)	SR02AC1 R									
		SR02AE1 R									
	300 (0 40)	SR03AC1 R									
		SR03AE1 R									
500 (0 67)	SR05AC1 R										

700 (0 93)	SR07AC1 R										

100 V	50 (0 07)	SRA5AC2 R									
		SRA5AE2 R									
	100 (0 13)	SR01AC2 R									
		SR01AE2 R									
	200 (0 27)	SR02AC2 R									
		SR02AE2 R									
	300 (0 40)	SR03AC2 R									

500 (0 67)	SR05AC2 R										

Notes

1 In the table above, / shows approximate scale of potentiometer
For example,  indicates 7/10 scale

2 The potentiometers other than listed in the Table above are provided for the SERVOPACK Do not tamper with these potentiometers except for a special case as they have been preset at the factory

(2) P Series

Table 10 4 Standard Adjustment and Setting Specifications

Class	Rated Output W (HP)	SERVOPACK Type CACR-	Applicable SERVOMOTOR			SERVOPACK Adjustment		
			Type USAPEM	Optical Encoder Pulses/rev	Rated Current ± ADC	Speed Setting	Starting Current Setting ± A	PG Frequency Dividing Ratio
200V	100 (0 13)	SR01AC1EP	01CE2	1500	10	3000r/min at rated speed reference	28	×1
		SR01AE1EP						
		SR01AC1FP	01CF2	1000				
		SR01AE1FP						
	200 (0 27)	SR02AC1EP	02CE2	1500	20		57	
		SR02AE1EP						
		SR02AC1FP	02CF2	1000				
		SR02AE1FP						
	300 (0 40)	SR03AC1EP	03CE2	1500	27		78	
		SR03AE1EP						
		SR03AC1FP	03CF2	1000				
		SR03AE1FP						
	500 (0 67)	SR05AC1EP	05CE2	1500	36		106	

		SR05AC1FP	05CF2	1000				

700 (0 73)	SR07AC1EP	07CE2	1500	57	163			

	SR07AC1FP	07CF2	1000					

Table 10 5 Standard Factory-adjusted Switch Settings

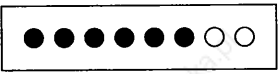
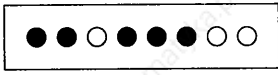
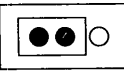
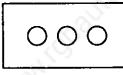
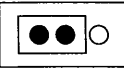
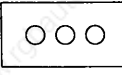
Class	SERVOPACK		SW1 (16P Setting Switch)	SW2 (Hexadecimal Digital Switch)	SEL1	SEL2	SEL3	SEL4
	Rated Output W(HP)	Type CACR-	Optical Encoder Pulse Setting	Dividing Ratio Setting	f/V Filter Time Constant Setting	Mode Switch (MS) Level Setting	MS/P-PI Selection	Test Mode
Standard 200V	100 (0 13)	SR01AC1EP	1500p/rev 1 2 3 4 5 6 7 8 	$\frac{1}{1}$	0 6ms 1 2 3	200% 1 2 3	MS Selection 1 2 3	1 2 3
		SR01AE1EP						
	200 (0.27)	SR02AC1EP						
		SR02AE1EP						
	300 (0 40)	SR03AC1EP						
		SR03AE1EP						
	500 (0 67)	SR05AC1EP						
700 (0.93)	SR07AC1EP							
Optional 200V	100 (0 13)	SR01AC1FP	1000p/rev 1 2 3 4 5 6 7 8 	10				
		SR01AE1FP						
	200 (0 27)	SR02AC1FP						
		SR02AE1FP						
	300 (0 40)	SR03AC1FP						
		SR03AE1FP						
	500 (0 67)	SR05AC1FP						
700 (0 93)	SR07AC1FP							

● Short-circuited ○ Open

Table 10 6 Standard Factory-adjusted Potentiometer Setting

Class V	SERVOPACK		VR1 IN-B	VR3 ZERO	VR5 CUR	VR6 LOOP	VR8 P-GAIN
	Rated Output W(HP)	SERVOPACK Type CACR-	Auxiliary Input Setting	Zero Drift Setting	Max Current Setting	Loop Gain Setting	Proportional Gain
200	100 (0 13)	SR01AC1 P	10V/rated speed (For user adjustment)	4 to 6/10	10/10 (max)	5/10	5/10
		SR01AE1 P					
	200 (0 27)	SR02AC1 P					
		SR02AE1 P					
	300 (0 40)	SR03AC1 P					
		SR03AE1 P					
	500 (0 97)	SR05AC1 P					
700 (0 93)	SR07AC1 P						

Notes

1 In the table above, / shows approximate scale of potentiometer
For example,  indicates 7/10 scale

2 The potentiometers other than listed in the Table above are provided for the SERVOPACK Do not tamper with these potentiometers except for a special case as they have been preset at the factory

10. 2 CHARACTERISTICS AT THE TIME OF DELIVERY

The SERVOPACK has been factory-adjusted as follows

- (1) Speed reference input-SERVOMOTOR speed ratio (no load) (Fig 10 1)

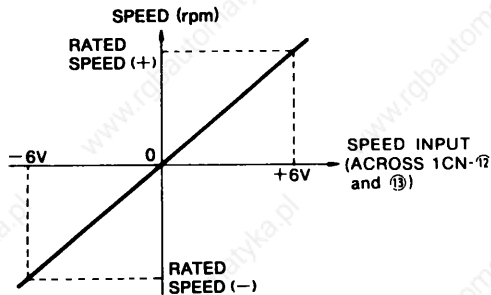

Fig 10 1 Speed Reference Input - SERVOMOTOR Speed Ratio

- (2) Speed Regulation (Fig 10 2)

Speed regulation ΔN , Δn

$$\frac{\Delta N}{N_R} \times 100\% \leq 0.1\%$$

$$\frac{\Delta n}{N_R} \times 100\% \leq 0.05\%$$

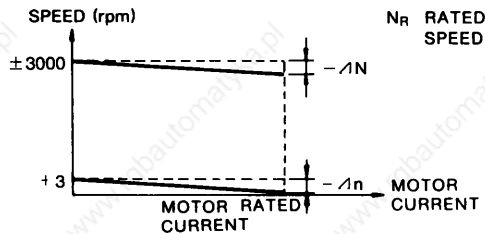

Fig 10 2 Speed Regulation

10. 2 CHARACTERISTICS AT THE TIME OF DELIVERY (Cont'd)

- (3) Start-stop characteristics (Fig 10 3)

I_p : Start current set value in Table 10 1 The overshoot (ΔN_{ov}) and undershoot (ΔN_{ud}) when $J_L = J_M$, are as shown in Table 10 7 (adjustment level preset at the factory)

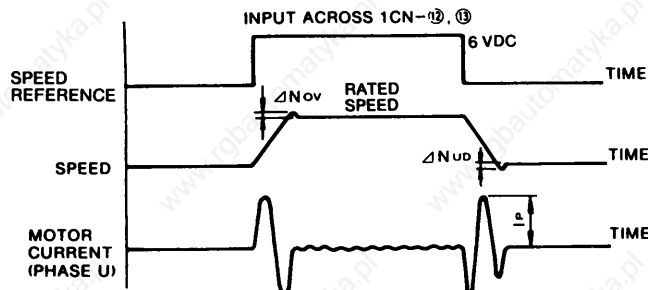

Fig 10 3 Start-Stop Characteristics

Table 10 7 Overshoot and Undershoot at Step Response

Type CACR-	<input type="checkbox"/> Nov/Nr X 100	<input type="checkbox"/> Nov/Nr X 100
SR AC	5% max	5% max
SR AE		

10. 3 READJUSTMENT

The SERVOPACK has been adjusted at the factory to obtain optimum characteristics, and readjustment is normally unnecessary. If adjustment is required depending on the use, re-adjust the SERVOPACK referring to Table 10 8 (Do not tamper with potentiometers)

10. 4 ADJUSTMENT PROCEDURES

Fig 10 4 shows the arrangement of potentiometers, and terminals for checking waveforms, Table 10 5 shows potentiometer adjustment, and Table 10 6 lists check terminals and functions

Adjust the potentiometers, observing the specified check locations (Potentiometers should not be tampered with) Fig 10 5 shows waveforms at the respective check terminals for step responses at no load

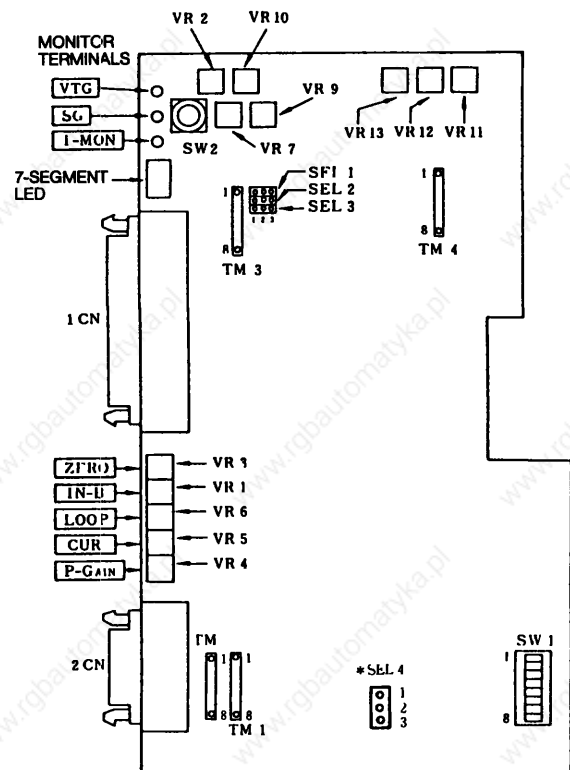

Fig 10 4 Printed Circuit Board for SERVOPACK
Type CACR-SRCA RCA and -SRCA REA

* SEL 4 is not provided with type CACR-SRCA RCA REV B

Table 10 8 Potentiometer Adjustment

Potentiometer	VR1 IN-B	VR4 P-GAIN	VR3 ZERO	VR5 CUR
Functions	Auxiliary input adjustment	Proportional gain adjustment	Zero drift adjustment	Starting current adjustment
How to Adjust	To be adjusted only when the rated reference voltage (± 2 to $\pm 10V$) is other than $\pm 6V$. Turn VR1 only to get the rated speed and do not operate other VRs	Turning VR4 CW increases proportional gain. Start/stop VR4 by the motor step input. Adjust so that the overshoot and undershoot decreases	To adjust so that the motor does not turn at the speed reference voltage 0V. Turning VR3 CW allows the motor to be finely adjusted in forward rotation and CCW in reverse rotation	Turning VR5 CW increases the starting current. This has been adjusted to full scale CCW at the factory
Characteristics	<p>--- CLOCKWISE (CW) — COUNTERCLOCKWISE (CCW)</p>	<ul style="list-style-type: none"> If the proportional gain is too high, overshoot or undershoot increases If the proportional gain is too low, rise or fall time is unstable 	<p>--- CW — CCW</p>	—
Adjustment	○	△	○	△

Potentiometer	VR6 LOOP
Functions	Speed loop gain adjustment
How to Adjust	To increase gain, turn VR6 CW
Characteristics	Turn VR6 CCW to prevent hunting
Adjustment	○

Adjustment Directions

Mark ○ Potentiometer should be adjusted in accordance with specifications and applications

Mark △ Potentiometer should not be adjusted except in special cases

Do not tamper with following potentiometers as they have been set at the factory

- VR2 VR9 VR10 (For speed feedback adjustment)
- VR7 (For max motor current adjustment)
- VR11, VR12, VR13 (For current offset adjustment)

10. 4 ADJUSTMENT PROCEDURES (Cont'd)

Table 10 9 Check Terminal Functions

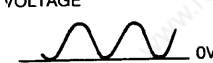
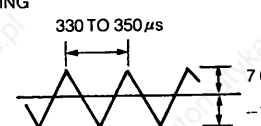
Equipment Symbol	Signal Name	Description	
TM1	1 PA	PG input signal	Phase A pulse input
	2 *PA		Phase A reverse input
	3 PB		Phase B pulse input
	4 *PB		Phase B reverse input
	5 PC		Phase C pulse input
	6 *PC		Phase C reverse input
	7 -	Not used	
8 PG5V	Optical encoder (PG) power supply voltage +5V		
TM2	1 PU	Phase U pulse input from pole sensor	
	2 *PU	Phase U reverse input	
	3 PV	Phase V pulse input from pole sensor	
	4 *PV	Phase V reverse input	
	5 PW	Phase W pulse input from pole sensor	
	6 *PW	Phase W reverse input	
	7 DIR	Monitoring of setting for motor running direction switching	
8 PG0V	Optical encoder (PG) power supply voltage 0V (PG, common terminal of signal from pole sensor)		
TM3	1 IN-A	For monitoring of speed reference input (connector 1CN between ⑫ and ⑬)	
	2 IN-B	For monitoring of speed reference aux input (connector 1CN between ⑭ and ⑮)	
	3 VTG	Motor speed monitoring ± 2.0 VDC $\pm 5\%$ /1000rpm	
	4 T-MON	Motor torque monitoring ± 3.0 VDC $\pm 5\%$ /100% torque	
	5 -	For future use	
	6 -	For future use	
	7 -	For future use	
	8 SG	Signal 0V	
TM4	1 Iu	U-phase current monitor	Type A5 01 02 03 05 07 A5 01 02 03 05
	2 Iv	V-phase current monitor	V/A 08 04 02 08 04 02
	3 U-sin	U-phase standard sin waveform monitor	VOLTAGE  0V Frequency varies on rotation speed Oscillation varies on torque
	4 V-sin	V-phase standard sin waveform monitor	
	5 OSC	Carrier frequency (chopping wave)	CHOPPING WAVE  330 TO 350 μs 70 TO 80V -70 TO -80V
	6 -	For future use	
	7 -	For future use	
	8 SG	Signal 0V	
CH 1	VTG	± 2.0 VDC $\pm 5\%$ /1000rpm	Front panel check terminal (for user observation)
CH 2	T-MON	± 3.0 VDC $\pm 10\%$ /100% torque	
CH 3	SG	Signal 0V	

Notes

- Do not touch any terminals other than check terminal with buffer amplifier on the front panel. The other terminals can be observed by using oscilloscope.
- When check terminals on a place other than panel are observed, keep adjacent check terminals away from each other. Otherwise, parts of internal circuit may be destroyed.

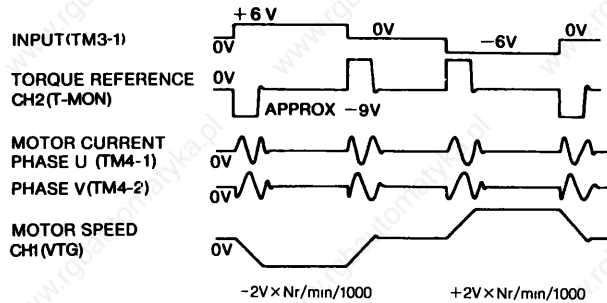

Fig 10 5 Waveforms at the Respective Check Terminals for Step Responses (No Load)

10. 5 SWITCH SETTING

The five switches (**SW1**, **SEL1**, **SEL2**, **SEL3**, **SEL4**) and hexadecimal digital switch **SW2**, have the following functions

Table 10 10 SW1 Setting and Functions

Setting Switch	No	Contents	Setting						Standard Setting Prior to Shipping										
			ON			OFF													
SW 1	1	Motor selection	1	2	Motor specifications				○										
			ON	ON	8p, 3000r/min														
	ON		OFF	Do not change the setting since this setting is for future use				○											
	OFF		ON																
	2	OFF	OFF																
		3	PG pulse selection	3	4	PG pulse specifications				○									
	ON	ON		1500p/rev															
	OFF	ON		1000p/rev				○											
ON	OFF	(for future use)																	
4	OFF	OFF																	
5	TGON level	1%(Approx 45r/min)			10%(Approx 450r/min)			○											
6	DB motion at OT	DB STOP			Coasting(base breaker)			○											
7	Alarm output code	Refer to Table 6 4						×											
8	Test mode	Test mode (Not to be used by user)			Normal setting			×											
SLE1 to 4 short pins set			1	2	3	1	2	3											
			○	○	○	○	○	○											
SLE1	f/V time constant		0 6ms			1 1ms			0 6ms	1-2									
SLE2	MS(mode switch) enabled	Level	MS disabled			Approx 0 2V or more			Approx 6V or more	Without shorting switch									
SLE3		Control signal	T-MON			IN-B input			Do not use	1-2									
SLE4	Test mode		Test mode (Not to be used by user)			Do not use			Normal setting	Without shorting switch									
SW 2	PG output pulse dividing ratio setting		0	1	2	3	4	5	6	7	8	9	A	B	C	D	E	F	「0」 (1 / 1)
			1/1	1/2	1/3	1/4	1/5	1/6	1/10	1/12	1/15	1/20	1/30	2/3	2/5	—	—	—	

Notes

- Switch ON, × Switch OFF (DIP Switch)
- SW1 DIP Switch, SW2 Digital Switch (rotary Switch)
- SLE4 is not provided with type CACR-SRCA RCA REV B SW1-7 is a test mode (Normal setting is "OFF")
- Do not perform "for future use" switch setting

11. INSPECTION AND MAINTENANCE

11. 1 AC SERVOMOTOR

The AC SERVOMOTOR has no wearing parts (e.g. brushes), so simple daily inspection is sufficient. The inspection schedule for the motor is shown in Table 11.1.

Do not disassemble the motor. If disassembly is necessary, contact your YASKAWA representative.

Table 11.1 Inspection Schedule for Motors

Inspection Item	Frequency	Inspection Operation	
Vibration	Daily	Feel manually	If abnormal vibration or noise is found, contact your YASKAWA representative.
Noise		Aurally	
Exterior and Cleaning	As required	Clean with dry cloth or compressed air.	
Insulation Resistance	Annually	Make sure that it is more than 10MΩ by measuring with a 500V megger after disconnecting the motor from the controller.	
Shaft Seal	Every 5,000 hours	Replace shaft seal.	
Overhaul	Every 20,000 hours or every 5 years	If worn or damaged, replace after disconnecting the motor from the driven machine. Contact your YASKAWA representative.	

11. 2 SERVOPACK

The SERVOPACK does not require any special maintenance. Remove dust and tighten screws periodically.

12. TROUBLESHOOTING GUIDE

12. 1 AC SERVOMOTOR

WARNING

Remedies in  should be practiced after turning off the power

Table 12 1 Troubleshooting Guide for AC SERVOMOTOR

Trouble	Cause	Corrective Action
Motor does not start	Loose connection	Tighten connection
	Wrong wiring	Correct wiring
	Overload	Reduce load or use a larger motor
Unstable operation	Wrong wiring	Inspect and correct wiring across motor terminals U, V, and W, and PG
Motor overheats	Excessive ambient temperature	Reduce ambient temperature below 40 °C
	Motor surface is dirty	Clean motor surface
	Overload	Reduce load or use a larger motor
Unusual noise	Motor loosely mounted	Tighten foundation bolts
	Motor misaligned	Realign
	Coupling out of balance	Balance coupling
	Noisy bearing	Check alignment, noise of bearing, lubrication and contact your YASKAWA representative
	Vibration of driven machine	Contact the machine manufacturer

12. 2 SERVOPACK

12 2 1 LED Indication (7-segment) for Troubleshooting

Table 12 2 LED Indication for Troubleshooting

LED	Detection	Lighting Condition	Probable Cause	Corrective Action
1.	Over-current	Goes ON when power is supplied to the control circuit	• Defective control circuit board (1 PWB)	• Replace the SERVOPACK
		Goes ON when power is supplied to the main circuit and servo power is turned ON • MCCB does not trip	• Defective current feedback circuit • Defective main circuit transistor module • Improper grounding	• Insert the 3CN connector firmly (for type SR AC) • Replace the SERVOPACK • Correct grounding
		Goes ON when power is supplied to the main circuit and servo power is turned ON • MCCB trips	• Defective motor grounding • Defective main circuit transistor module	• Replace the motor • Replace the SERVOPACK
		Goes ON when power is supplied to the main circuit	• Defective main circuit transistor module	• Replace the SERVOPACK
		Goes ON when the motor is running	• Faulty internal elements • Defective internal elements	• Replace the SERVOPACK
2.	Circuit protector tripped	Goes ON when power is supplied to the control circuit	• Defective control circuit board (1 PWB)	• Replace the SERVOPACK
		Goes ON when power is supplied to the main circuit	• Defective main circuit thyristor-diode module • MCCB trips	• Replace the SERVOPACK • Check if there is disconnection in the wiring leads in SERVOPACK • Check the conduction state on connecting parts
3.	Regenerative trouble	Goes ON when power is supplied to the control circuit	• Defective control circuit board (1 PWB)	• Replace the SERVOPACK
		Goes ON approximate 0.5 to 1 second after power is supplied to the main circuit	• Defective regenerative transistor • Regenerative resistor disconnection	• Replace the SERVOPACK • Check and replace the regenerative resistor (Replace the SERVOPACK)
4.	Over-voltage	Goes ON when the motor accelerates or decelerates	• Load inertia (GD^2) is too large	• Check the inertia of the machine with the value converted to the motor shaft
			• Defective regenerative circuit	• Replace the SERVOPACK
5.	Over-speed	When the reference is input, the motor runs fast and 5 goes ON	• Motor connection error • Optical encoder connection error • Improper grounding	• Correct the motor connection • Check and correct pulses in phases A, B, C, U, V and W on 2CN • Correct gains
			• The reference input voltage is too large	• Decrease the reference input voltage
6.	Voltage drop	Goes ON when power is supplied to the main circuit	• Defective main circuit thyristor-diode module	• Replace the SERVOPACK
7.	Overload	Goes ON when power is supplied to the control circuit	• Defective control circuit board (1 PWB)	• Replace the SERVOPACK
		Goes ON during operation • When power to the control circuit is turned OFF and then ON again, the operation starts	• Operation with 105% to 130% or more of the rated load	• Check and correct the load (may be overload)
		The motor rotates, but the torque is unavailable. When power to the control circuit is turned OFF and then ON again, the operation starts, but the torque is still unavailable	• Motor circuit error connection, such as U→V, V→W, W→U or single-phase connection	• Correct the connection

Table 12 2 LED Indication for Troubleshooting (Cont'd)

LED	Detection	Lighting Condition	Probable Cause	Corrective Action
b.	A/D error	Goes ON when power is supplied to the control circuit	• Defective control circuit board (1PWB)	• Replace the SERVOPACK
	CPU fault	Goes ON during operation	• Faulty internal elements	• Resume after reset operation
• Defective internal elements			• Replace the SERVOPACK	
c.	Overrun prevention	Goes ON when power is supplied to the control circuit	• Defective control circuit board (1 PWB)	• Replace the SERVOPACK
		The motor starts momentarily, then c goes ON	• Motor connection error	• Correct the motor connection
			• Optical encoder connection error	• Check and correct pulses in phases A, B, C, U, V and W with 2CN

12 2 2 Examples of Troubleshooting for Defective Wiring or Parts

Table 12 3 Example of Troubleshooting for Defective Wiring or Parts

Trouble	Check Items	Corrective Action
MCCB trips immediately after Power ON and Servo ON	• Main circuit wiring (such as the ground of motor)	• Correct the wiring
The reference is input, but the motor does not run	• Voltage across Ⓜ, and Ⓢ • LED [MAIN] ON • Speed reference voltage • Alarm LED is not ON	• Check the AC power supply circuit • If LED is ON, check the cause • Adjust by using reference setting volume

12 2 3 Examples of Troubleshooting for Incomplete Adjustment

Table 12 4 Examples of Troubleshooting for Incomplete Adjustment

Trouble	Cause	Corrective Action
Motor rotates even if the speed reference voltage is 0 V	Incomplete ZERO potentiometer adjustment	Adjust VR3 [ZERO] correctly
Motor vibrates or vibration frequency is too high, approx 200 to 300 Hz (When vibration frequency equals commercial frequency)	Speed loop gain too high • Excessively long lead of SERVOPACK input circuit • Noise interference due to bundling of signal line and power line	Turn VR6 [LOOP] CW to increase the speed loop gain • Decrease length of lead • Separate input circuit line from power line or connect input circuit to low impedance less than several 100 ohms
Motor speed overshoot is too much at acceleration and deceleration	• Speed loop gain is too high	• Turn VR6 [LOOP] CW to increase the speed loop gain

NOTE

www.rgbautomatyka.pl

AC SERVO DRIVES

R, P SERIES FOR SPEED CONTROL

SERVOMOTOR : TYPES USAREM, USAPEM (with Optical Encoder)

SERVOPACK : TYPES CACR-SR: AC (Rack-mounted Type)

CACR-SR: AE (Rack-mounted Type)

TOKYO OFFICE Ohtemachi Bldg, 1-6-1 Ohtemachi, Chiyoda-ku, Tokyo, 100 Japan
Phone (03) 3284-9111, -9145 Telex YASKAWA J33530 Fax (03) 3284-9034

SEOUL OFFICE Seoul Center Bldg, 91-1, Sogong-Dong, Chung-ku, Seoul, Korea
Phone (02) 776-7844 Fax (02) 753-2639

TAIPEI OFFICE Union Commercial Bldg, 14F, 137, Nanking East Road, Sec 2, Taipei, Taiwan
Phone (02) 507-7065, -7732 Fax (02) 506-3837

YASKAWA ELECTRIC AMERICA, INC SUBSIDIARY

Chicago-Corporate Headquarters 2942 MacArthur Blvd Northbrook, Illinois 60062-2028, U S A
Phone (708) 291-2340 Fax (708) 498-2430

Chicago-Technical Center 3160 MacArthur Blvd Northbrook, Illinois 60062 1917, U S A
Phone (708) 291-0411 Fax (708) 291-1028

Los Angeles Office 5626 Corporate Avenue Cypress, CA, 90630, U S A
Phone (714) 828-9692 Fax (714) 828-1165

New Jersey Office 30 Two Bridges Road, Fairfield, New Jersey 07006, U S A
Phone (201) 575-5940 Fax (201) 575-5947

YASKAWA ELECTRIC EUROPE GmbH SUBSIDIARY

Niederhochstadter Straße 73, 61476 Kronberg-Oberhochstadt, Germany
Phone (06173) 938-0 Telex 415660 YASE D Fax (06173) 68421

YASKAWA ELÉTRICO DO BRASIL COMÉRCIO LTDA. SUBSIDIARY

Av Brig Faria Lima, 1664-cj 721/724, Pinheiros, São Paulo-SP, Brasil CEP-01452
Phone (011) 813-3933, 813-3694 Telex (011) 82869 YSKW BR Fax (011) 815-8795

YASKAWA ELECTRIC (SINGAPORE) PTE LTD

CPF Bldg, 79 Robinson Road No 13-05, Singapore 0106
Phone 2217530 Telex (87) 24890 YASKAWA RS Fax (65) 224-5854



YASKAWA

YASKAWA ELECTRIC CORPORATION