

SKD 25



Power Bridge Rectifiers

SKD 25

Features

- Square plastic case with isolated metal base plate and fast-on connectors
- Blocking voltage to 1600 V
- High surge current
- Easy chassis mounting
- UL recognized, file no. E 63 532

Typical Applications*

- Three phase rectifier for power supplies
- Input rectifiers for variable frequency drives
- Rectifier for DC motor field supplies
- Battery charger rectifiers
- Recommended snubber network: RC: 50 Ω, 0.1 μF ($P_R = 1 \text{ W}$)

- 1) Freely suspended or mounted on an insulator
- 2) Mounted on a painted metal sheet of min. 250 x 250 x 1 mm

V_{RSM}, V_{RRM} V	V_{VRMS} V	$I_D = 20 \text{ A } (T_c = 73^\circ\text{C})$ Types	C_{max} μF	R_{min} Ω
200		SKD 25/02		0,15
400		SKD 25/04		0,3
800		SKD 25/08		0,7
1200		SKD 25/12		1
1400		SKD 25/14		1,2
1600		SKD 25/16		1,5

Symbol	Conditions	Values	Units
I_D	$T_a = 45^\circ\text{C}$, isolated ¹⁾ $T_a = 45^\circ\text{C}$, chassis ²⁾	3,5 12	A A
I_{DCL}	$T_a = 45^\circ\text{C}$, isolated ¹⁾ $T_a = 45^\circ\text{C}$, chassis ²⁾ $T_a = ^\circ\text{C}$,	3,5 12	A A A
I_{FSM}	$T_{vj} = 25^\circ\text{C}$, 10 ms $T_{vj} = 150^\circ\text{C}$, 10 ms	370 320	A A
i^2t	$T_{vj} = 25^\circ\text{C}$, 8,3 ... 10 ms $T_{vj} = 150^\circ\text{C}$, 8,3 ... 10 ms	680 500	A ² s A ² s
V_F	$T_{vj} = 25^\circ\text{C}$, $I_F = 150 \text{ A}$	max. 2,2	V
$V_{(TO)}$	$T_{vj} = 150^\circ\text{C}$	max. 0,85	V
r_T	$T_{vj} = 150^\circ\text{C}$	max. 12	mΩ
I_{RD}	$T_{vj} = 25^\circ\text{C}$, $V_{RD} = V_{RRM}$ $T_{vj} = ^\circ\text{C}$, $V_{RD} = V_{RRM} \geq V$	300	μA μA
I_{RD}	$T_{vj} = 150^\circ\text{C}$, $V_{RD} = V_{RRM}$ $T_{vj} = ^\circ\text{C}$, $V_{RD} = V_{RRM} \geq V$	5	mA mA
t_{tr}	$T_{vj} = 25^\circ\text{C}$	10	μs
f_G		2000	Hz
$R_{th(j-a)}$	isolated ¹⁾ chassis ²⁾	15 4,7	K/W K/W
$R_{th(j-c)}$	total	1,75	K/W
$R_{th(c-s)}$	total	0,15	K/W
T_{vj}		- 40 ... + 150	°C
T_{stg}		- 55 ... + 150	°C
V_{isol}	a. c. 50 ... 60 Hz; r.m.s.; 1 s / 1 min. to heatsink	3000 / 2500 2 ± 15 %	V~ Nm Nm m/s ²
M_s			
M_t			
a			
w		26	g
F_u		20	A
Case		G 11b	

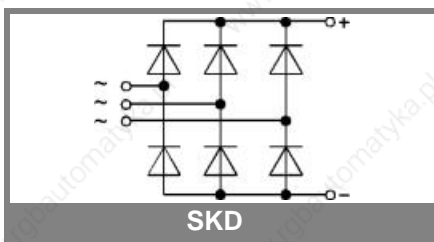

SKD 25

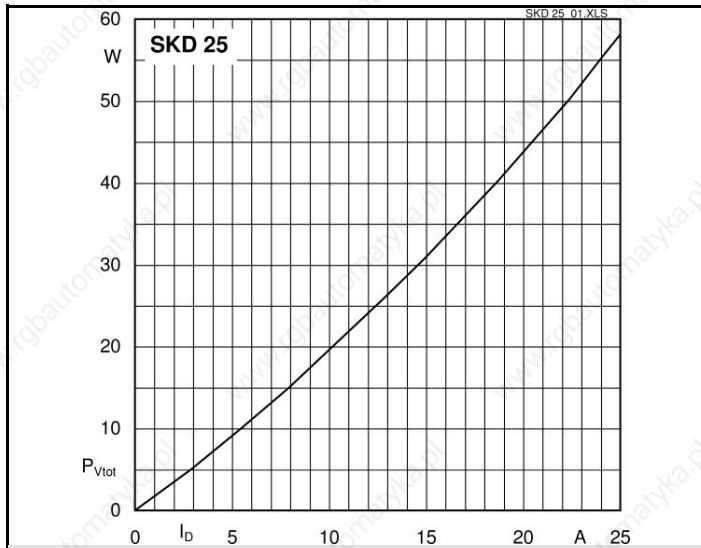

Fig. 3L Power dissipation vs. output current

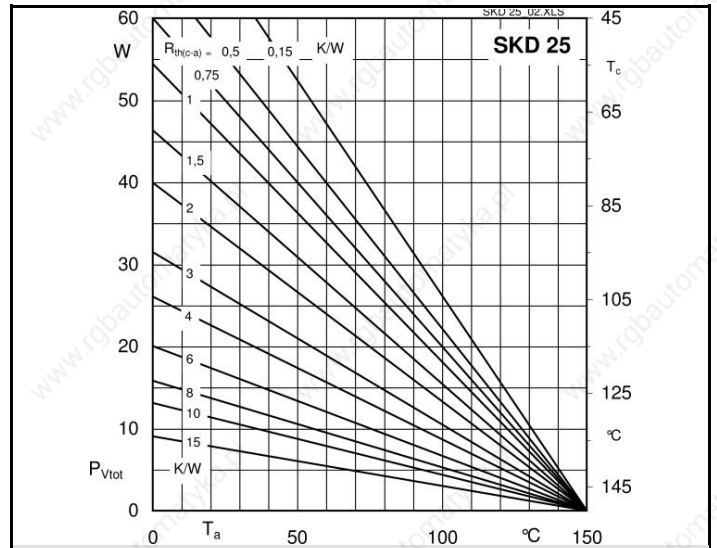

Fig. 3R Power dissipation vs. case temperature

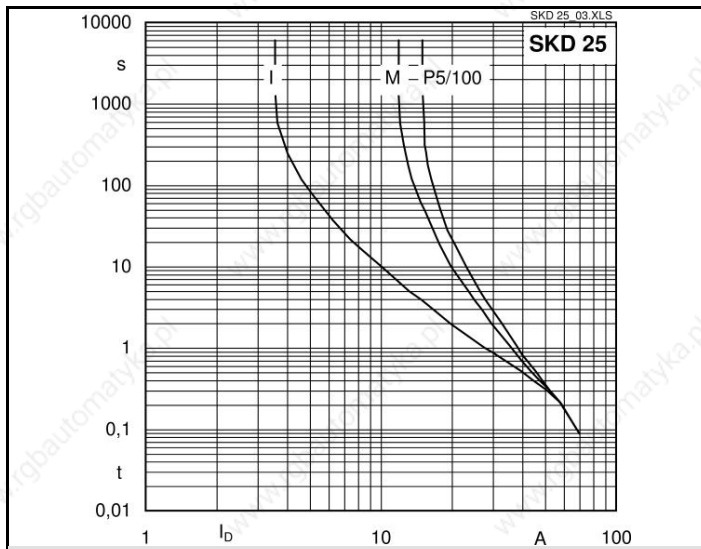

Fig. 6 Rated overload characteristics vs. time

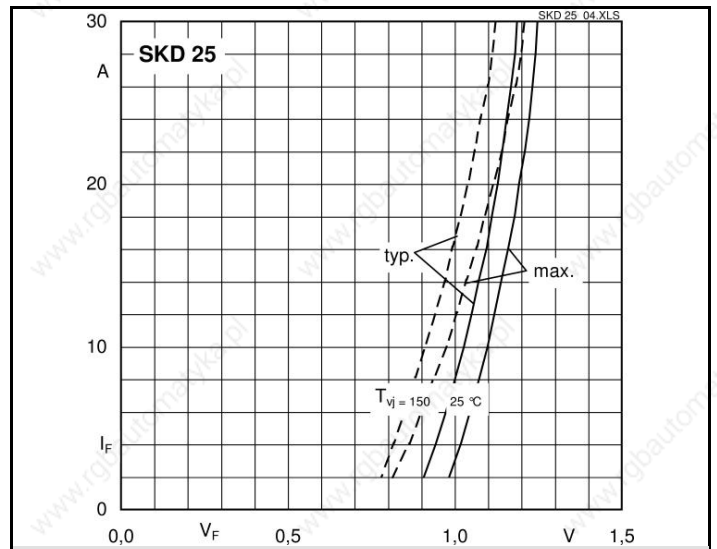
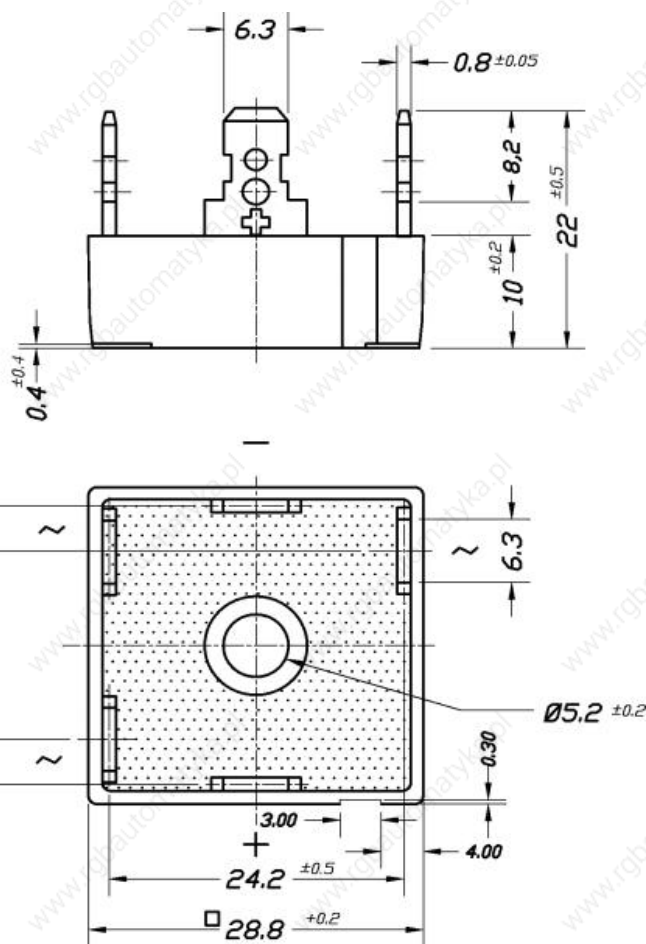

Fig. 9 Forward characteristics of a diode arm



Case G 11b

* The specifications of our components may not be considered as an assurance of component characteristics. Components have to be tested for the respective application. Adjustments may be necessary. The use of SEMIKRON products in life support appliances and systems is subject to prior specification and written approval by SEMIKRON. We therefore strongly recommend prior consultation of our personal.