

CAL5-11, CAL5-11B CCL5-01, CDL5-01 CCL5-11

Operating instructions
Betriebsanleitung
Notice d'instructions
Instruktion
Istruzioni tecniche
Instrucciones de empleo

Auxiliary contacts
Hilfsschalter
Contacts auxiliaires
Kontaktblock
Contatti ausiliari
Contactos auxiliares

N..., NE..., A/AE/TAE9...75
AF45...75, UA16...75

A95...300
AF95...750
(T)AE95...110
UA95...110

manufactured before week
hergestellt vor Woche
fabriqués avant semaine
tillverkad före vecka
fabbricato primadi settimana
manufacturados antes semana

36 - 2003
(date code 0336)

FPTC 407744 P0001- 07/03

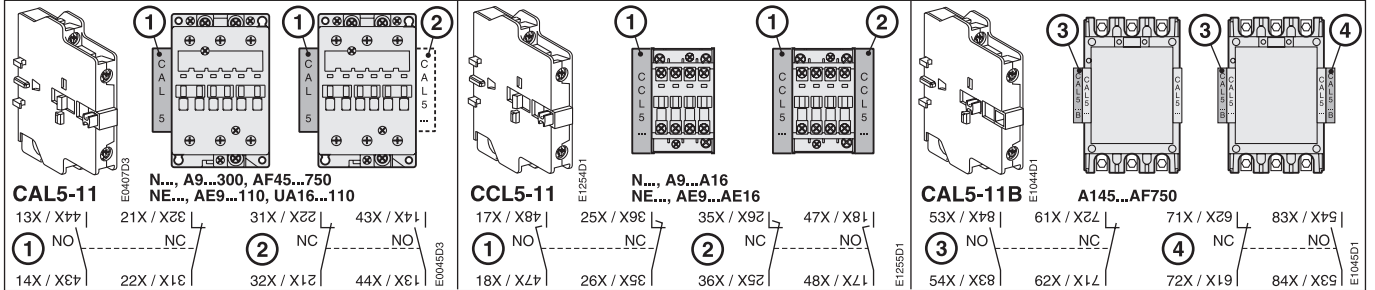

Assembly - Anbau
Montage - Montering
Montaggio - Montaje

CAL5-11
CCL5-11

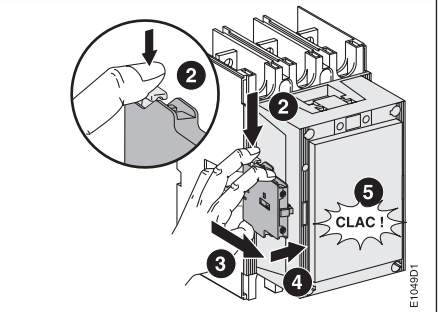
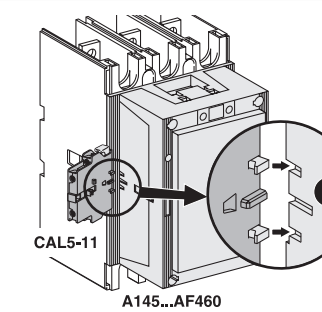
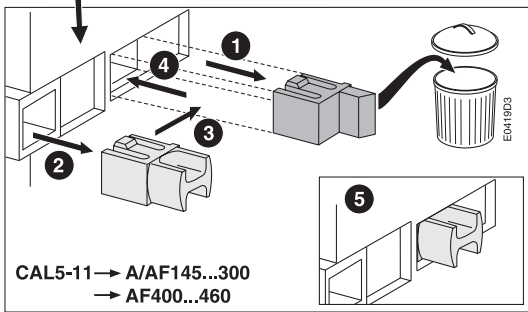
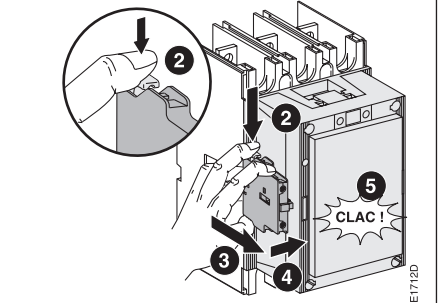
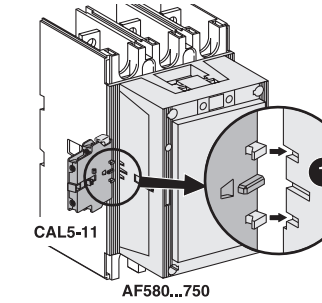
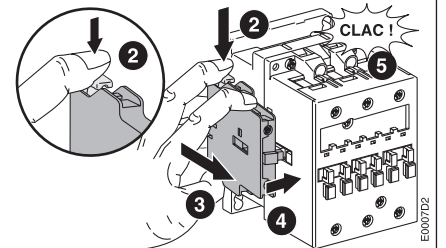
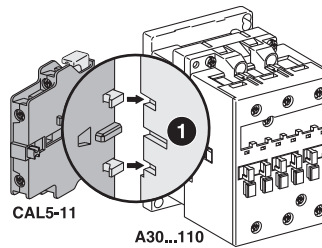
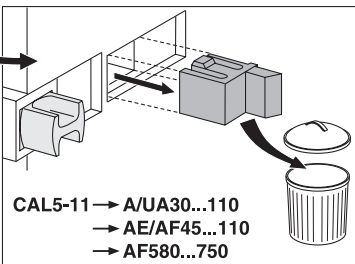
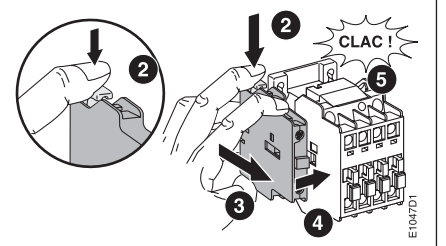
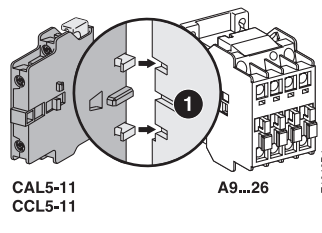
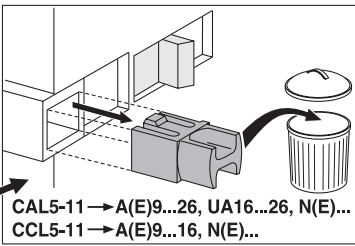

Assembly - Anbau - Montage - Montering - Montaggio - Montaje
CAL5-11B

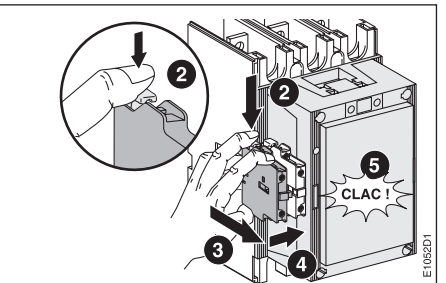
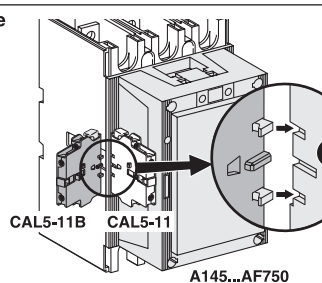
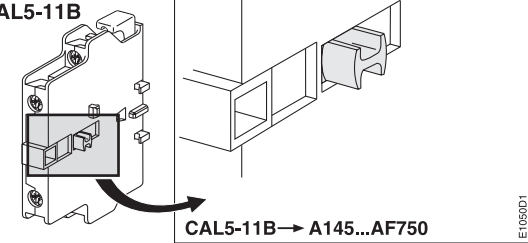

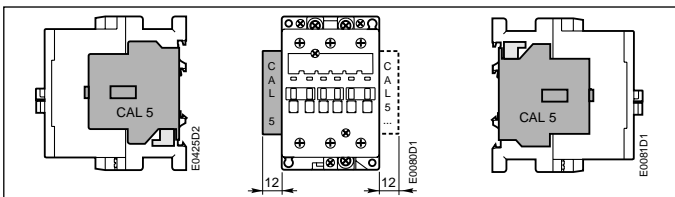

N..., A9...110, UA16...110, NE..., AE9...110, AF45...110

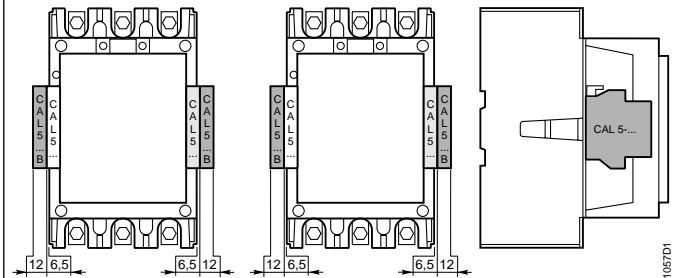

A/AF145, A/AF185

A/AF210...300

A/AF145...300

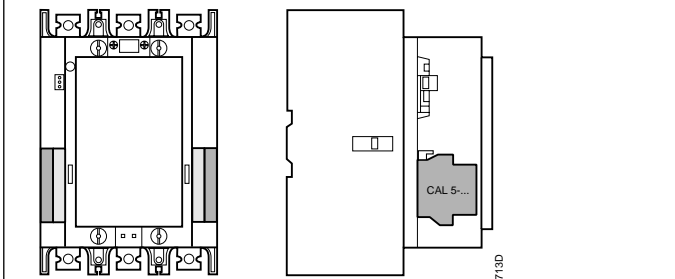

AF400...750

CAL5-11 CAL5-11B CCL5-11						
	M 3,5 1 N.m	Ø 5,5	pozidriv N°2	2 x 1...4	2x 0,75...2,5	> 3,5 L < 8

CDL5-01
CCL5-01

CDL5-01
CCL5-01

CDL5-01
CCL5-01

A1, A2, A3

V d.c., A1, A2, A3

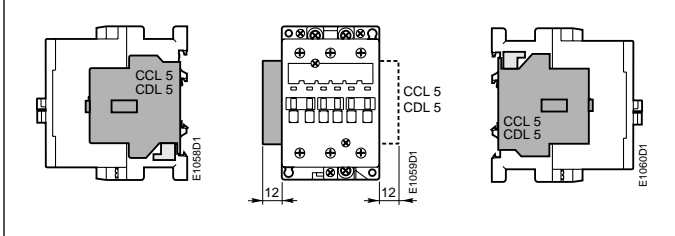

①	+
N40E, N22E, N31E NE12E, NE21E, NE30E A9...A40-30-10/-30-01 AE9...AE40-30-00 A9...A26-40-00/-22-00 A45...A75-40-00/-22-00 A50...A110-30-00	②③④
① + ②	+
N44E...N80E A9...A40-30-32 A9...A16-30-22 A50...A110-30-22	③④

①	+
A50...A110 -30-11	②
A145...AF750-30-11	②③④
① + ②	+
A145...AF750-30-22	③④

①	+
AE50...AE110-30-00 AE45...AE75-40-00	③④

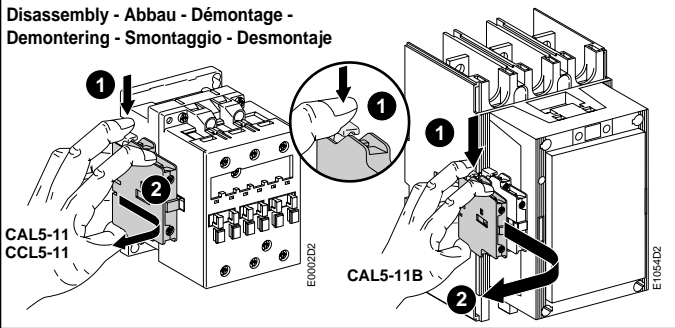

Assembly - Anbau - Montage - Monterij - Montaggio - Montaje

CDL5
CCL5

CDL5-01	(T)AE50...75-30-00 (T)AE50...75-30-11 (T)AE45...75-40-00 AE45...75-22-00
CCL5-01	AE95...110-30-00 AE95...110-30-11

Pozidriv n°2
1 Nm - 9 lb.in

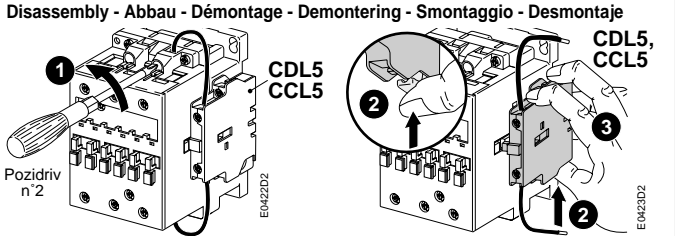

Warning ! The operation, installation and servicing of this appliance must be carried out by a qualified electrician applying the relevant rules of the art, installation standards and safety regulations. Before operating the contactors, check that control voltage complies with the data on the coil mounting bracket. Connection to other control voltage can destroy the coil. Do not touch live parts. Danger !

Warnung ! Die Inbetriebnahme und die Installation des vorhandenen Gerätes sowie jegliche Wartungsarbeiten müssen durch einen Fachelektriker, der die anerkannten technischen Regeln, die Montagenormen und die Sicherheitsvorschriften beachtet, durchgeführt werden. Vor Inbetriebnahme der Schütze prüfen ob Steuerspannung am Verwendungsort mit den aufgedruckten Spulendaten übereinstimmt. Der Anschluss einer anderen Steuerspannung kann zur Zerstörung der Spule führen. Spannung führende Teile nicht berühren. Lebensgefahr !

Attention ! La mise en œuvre, l'installation de cet appareil et toute intervention doivent être effectuées par un électricien professionnel appliquant les règles de l'art, les normes d'installation et les règlements de sécurité. Avant la mise en marche des contacteurs, vérifier que la tension du circuit de contrôle correspond bien aux indications de la bobine. Le raccordement d'une tension différente peut mener à une destruction de la bobine. Ne pas toucher les pièces sous tension. Danger de mort !

Varning ! Igångsättning och installation av apparaten samt alla ingrepp bör utföras av en kompetent elektriker enligt gällande installationsnormer och säkerhetsregler. Kontrollera före installation av kontaktorn att aktuell manöverspänning överensstämmer med spolens märkdata. Felaktig manöverspänning kan skada spolen. Beröring av spänningsförande delar är förenat med livsfara.

Attenzione ! La messa in opera, l'installazione di questo apparecchio ed ogni tipo di intervento devono essere effettuati da un elettricista professionista il quale applichi le regole del mestiere, le norme di installazione ed i regolamenti di sicurezza. Prima della messa in servizio del contattore, verificare che la tensione del circuito di comando corrisponda esattamente a quella indicata sulla bobina. L'alimentazione con una tensione diversa, può provocare la distruzione della bobina. Non toccare le parti attive. Pericolo di vita !

Atención ! La puesta en aplicación, la instalación de este aparato y cualquier intervención deben realizarse por un electricista profesional que aplique las reglas del oficio, las normas de instalaciones y la reglamentación de seguridad. Antes de la puesta en servicio del contactor, comprobar si coinciden la tensión de mando con los datos impresos en la bobina. La conexión de otra tensión de mando puede producir la destrucción de la bobina. Las partes bajo tensión no deben tocarse. Peligro de muerte !

