

# SIEMENS

## SIMATIC HMI

### TP27, TP37 Touch Panels

#### Equipment Manual

#### Preface, Contents

---

		<b>1</b>
<b>Part I</b>	Introduction	∇
		<b>2</b>

---

		<b>3</b>
<b>Part II</b>	Functions of the Touch Panels	∇
		<b>11</b>

---

		<b>12</b>
<b>Part III</b>	Installation and Commissioning	∇
		<b>13</b>

---

		<b>14</b>
<b>Part IV</b>	Device Description and Maintenance	∇
		<b>18</b>

---

		<b>A</b>
<b>Part V</b>	Appendices	∇
		<b>E</b>

---

#### Glossary, Index

6AV3991-1AJ02-0AB0

Release 01/00

## Safety Guidelines

This manual contains notices which you should observe to ensure your own personal safety, as well as to protect the product and connected equipment. These notices are highlighted in the manual by a warning triangle and are marked as follows according to the level of danger:



### Warning

indicates that death, severe personal injury or substantial property damage **can** result if proper precautions are not taken.



### Caution

indicates that minor personal injury or property damage can result if proper precautions are not taken.

### Note

draws your attention to particularly important information on the product, handling the product, or to a particular part of the documentation.

## Qualified Personnel

Equipment may be commissioned and operated only by **qualified personnel**. Qualified personnel within the meaning of the safety notices in this manual are persons who are authorized to commission, ground and identify equipment, systems and circuits in accordance with safety engineering standards.

## Correct Usage

Note the following:



### Warning

The equipment may be used only for the applications stipulated in the catalog and in the technical description and only in conjunction with other equipment and components recommended or approved by Siemens.

Startup must not take place until it is established that the machine, which is to accommodate this component, is in conformity with the guideline 89/392/EEC.

Faultless and safe operation of the product presupposes proper transportation, proper storage, erection and installation as well as careful operation and maintenance.

## Approvals

The approvals that apply to the device are detailed in the Chapter *Technical Data*.

## Trademarks

SIMATIC®, SIMATIC HMI®, SIMATIC Multi Panel®, SIMATIC Multifunctional Panel®, ProTool/Lite®, ProTool®, ProTool/Pro® and MP270® are registered trademarks of Siemens AG.

Some of the other designations used in these documents are also registered trademarks; the owner's rights may be violated if they are used by third parties for their own purposes.

## Impressum

Editor and Publisher: A&D PT1

### Copyright © Siemens AG 1999 All rights reserved

The reproduction, transmission or use of this document or its contents is not permitted without express written authority. Offenders will be liable for damages. All rights, including rights created by patent grant or registration of a utility model or design, are reserved.

Siemens AG,  
Automation & Drives  
SIMATIC Human Machine Interface  
Postfach 4848, D-90327 Nuernberg

### Disclaimer of Liability

We have checked the contents of this manual for agreement with the hardware and software described. Since deviations cannot be precluded entirely, we cannot guarantee full agreement. However, the data in this manual are reviewed regularly and any necessary corrections included in subsequent editions. Suggestions for improvement are welcomed.

Technical data subject to change.  
© Siemens AG 1999

# Preface

## Purpose

This equipment manual provides operation, installation, configuration and system service personnel with information concerning functionality, operation and technical design of the Touch Panels TP27 and TP37.

## Organization of the manual

The equipment manual *Touch Panel TP27, TP37* is organized into five parts:

Part	Chapters	Contents
I	1 - 2	Overview of the Touch Panel and range of functions in tabular form.
II	3 - 11	Step-by-step instructions on how to operate the Touch Panel using the standard screens.
III	12 - 13	<ul style="list-style-type: none"><li>– Mechanical and electrical installation,</li><li>– Commissioning</li><li>– Touch Panel operating modes.</li></ul>
IV	14 - 18	Detailed information on the Touch Panel and maintenance.
V	Appendix	<ul style="list-style-type: none"><li>– Technical data,</li><li>– Interface assignments,</li><li>– System messages,</li><li>– SIMATIC HMI documentation,</li><li>– ESD guidelines,</li><li>– Glossary of technical terms.</li></ul>

## Conventions

The following conventions are used throughout this manual:

<i>Motor off</i>	Text in the Touch Panel display is presented in this typewriter font.
<i>Variable</i>	Symbolic names representing variable values on the screen are presented in this italic typewriter font
<i>Screens</i>	Functions selected by the user are presented in this standard italic font.
ESC	The labels of buttons are presented in a different typeface.

## History

The various releases of the equipment manual correspond to the following firmware and ProTool versions:

Release	Remarks	ProTool version
04/97	First release of the TP37 equipment manual	V 3.0 and later
10/97	Inclusion of TP27, inclusion of touch screen functionality	V 4.0 and later V 4.0 and later
09/98	Inclusion of the TP27-10; new standard screen for printing messages	V 5.0
01/99	Inclusion of standard screens for Status/Force and Clean Screen	V 5.1
01/00	Inclusion of the JEIDA/PCMCIA card for the TP27-6.	V 5.2

**Other support**

In the case of technical queries, please contact your local Siemens in the subsidiaries and branches responsible for your area.

**SIMATIC Customer Support Hotline**

Available worldwide, at all times:

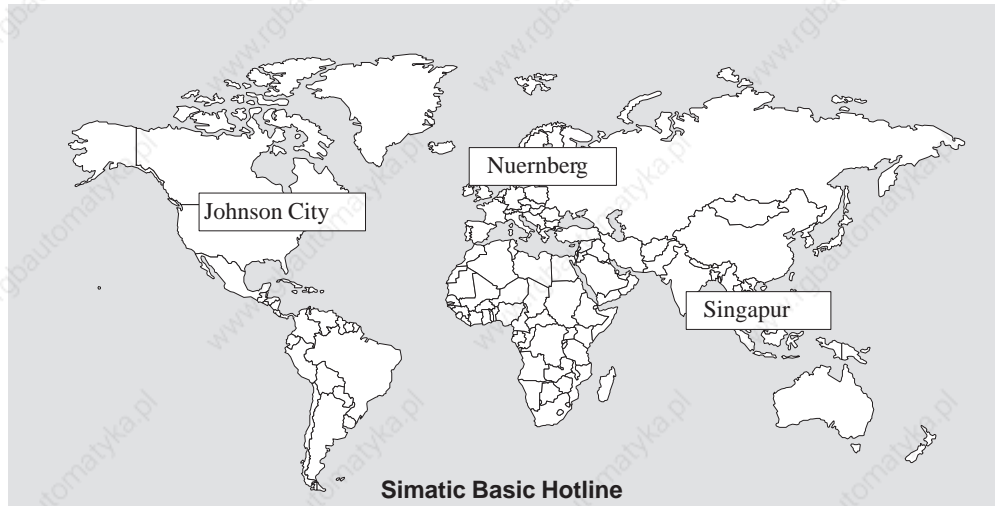
**Nuernberg****SIMATIC BASIC Hotline**

Local time:  
Mon - Fri 8:00 to 18:00

Telephone:  
+49 (911) 895-7000

Fax: +49 (911) 895-7002

E-Mail: [simatic.support@nbgm.siemens.de](mailto:simatic.support@nbgm.siemens.de)

**SIMATIC Premium Hotline**

(charged, only with  
SIMATIC Card)

Time:  
Mon - Fri 0:00 to 24:00

Telephone:  
+49 (911) 895-7777

Fax:  
+49 (911) 895-7001

**Johnson City****SIMATIC BASIC Hotline**

Local time:  
Mon - Fri 8:00 to 17:00

Telephone:  
+1 423 461-2522

Fax: +1 423 461-2231

E-Mail: [simatic.hotline@sea.siemens.com](mailto:simatic.hotline@sea.siemens.com)

**Singapur****SIMATIC BASIC Hotline**

Local time:  
Mon - Fri 8:00 to 17:30

Telephone:  
+65 740-7000

Fax: +65 740-7001

E-Mail: [simatic@singnet.com.sg](mailto:simatic@singnet.com.sg)

## SIMATIC Customer Online Services

SIMATIC Customer Support offers comprehensive additional information concerning SIMATIC products through its Online services as follows:

- Up-to-date general information is provided
  - in **Internet** under <http://www.ad.siemens.de/simatic>
  - via **Fax-Polling** under 08765-93 02 77 95 00
- Up-to-date product information and downloads for practical use can be found:
  - in **Internet** under <http://www.ad.siemens.de/support/html-00/>
  - via the **Bulletin Board System** (BBS) in Nürnberg (*SIMATIC Customer Support Mailbox*) under +49 (911) 895-7100

In order to contact the mailbox, please use a modem with up to 28.8 kBaud (V.34) capacity. Set the parameters as follows: 8, N, 1, ANSI, or dial for connection via ISDN (x.75, 64 kBit).

## Abbreviations

The abbreviations used in this equipment manual have the following meaning:

AM	Alarm Message
ANSI	American National Standards Institute
AS511	Protocol of the PU interface to SIMATIC S5
ASCII	American Standard Code for Information Interchange
CPI	Control Panel Interface
CPU	Central Processing Unit
DIL	Dual-In-Line (package)
DP	Decentral Periphery
DRAM	Dynamic Random Access Memory
DKM	Direct Key Module
EM	Event message
ESD	Electrostatic Sensitive Device
LCD	Liquid Crystal Display
LED	Light-Emitting Diode
MPI	Multipoint Interface (SIMATIC S7)
PC	Personal Computer
PLC	Programmable Logic Controller
PU	Programming Unit
PPI	Point to Point Interface (SIMATIC S7)
SRAM	Static Random Access Memory
STN	Super Twisted Nematic
TFT	Thin Film Transistor
TP	Touch Panel
TTL	Transistor-Transistor Logic

# Contents

## Part I INTRODUCTION

<b>1</b>	<b>Product Description</b> .....	<b>1-1</b>
1.1	Visualizing and Controlling Processes .....	1-3
1.2	The Touch Panels at a Glance .....	1-5
<b>2</b>	<b>Functionality</b> .....	<b>2-1</b>

## Part II FUNCTIONS OF THE TOUCH PANELS

<b>3</b>	<b>General Operation</b> .....	<b>3-1</b>
3.1	Operating Touch Elements .....	3-4
3.2	Entering Values .....	3-6
3.2.1	Entering Numerical Values .....	3-6
3.2.2	Entering Alphanumeric Values .....	3-8
3.2.3	Entering Symbolic Values .....	3-10
3.3	Help Text .....	3-11
<b>4</b>	<b>Screens</b> .....	<b>4-1</b>
4.1	Screen Elements .....	4-1
4.2	Standard Screens .....	4-3
<b>5</b>	<b>Password Protection</b> .....	<b>5-1</b>
5.1	Password Level and Access Permissions .....	5-1
5.2	Login/Logout on the Touch Panel .....	5-3
5.3	Password Management .....	5-5
<b>6</b>	<b>Messages</b> .....	<b>6-1</b>
6.1	Types of Message .....	6-2
6.1.1	Event Messages and Alarm Messages .....	6-2
6.1.2	Alarm Messages .....	6-6
6.1.3	System Messages .....	6-8
6.2	Displaying Messages .....	6-9
6.2.1	Opening a Message Page .....	6-11
6.2.2	Opening a Message Buffer .....	6-13
6.3	Deleting Messages .....	6-14

6.4	Printing Messages .....	6-16
6.5	ALARM_S Messages .....	6-18
6.5.1	Communication Sequence .....	6-19
6.5.2	Message Acknowledgement .....	6-20
6.5.3	Printing Messages .....	6-20
6.5.4	Message Overload .....	6-21
6.5.5	Updating .....	6-22
6.5.6	Buffer Overflow .....	6-23
6.6	Standard Screens for Messages .....	6-24
6.6.1	“Edit Message” Standard Screen .....	6-24
6.6.2	“Output Messages” Standard Screen .....	6-26
6.6.3	“System Settings” Standard Screen .....	6-28
<b>7</b>	<b>Printing .....</b>	<b>7-1</b>
<b>8</b>	<b>Recipes .....</b>	<b>8-1</b>
8.1	Standard Screens for Recipes .....	8-3
8.1.1	Creating, Editing and Saving Data Records .....	8-8
8.1.2	Transferring Data Records .....	8-13
8.2	Record Sets .....	8-15
<b>9</b>	<b>Storing and Loading Data .....</b>	<b>9-1</b>
9.1	Data Types, Data Media and Storage Principle .....	9-1
9.2	Delete Storage Medium .....	9-3
9.3	Backup/Restore .....	9-5
<b>10</b>	<b>Status/Force Variable Using the TP .....</b>	<b>10-1</b>
10.1	Status Variable .....	10-2
10.2	Force Variable .....	10-5
<b>11</b>	<b>System Settings .....</b>	<b>11-1</b>
11.1	Setting an Operating Mode .....	11-4
11.2	Blanking the Screen .....	11-5
11.3	Deactivate Touch Screen .....	11-6
11.4	Calibrating the Touch Screen (TP37 and TP27-10 only) .....	11-7
11.5	Other Settings .....	11-8

### Part III INSTALLATION AND COMMISSIONING

<b>12</b>	<b>Installation .....</b>	<b>12-1</b>
12.1	Mechanical Installation .....	12-2
12.2	Electrical Installation .....	12-6
12.2.1	Power Supply and Relay Contacts .....	12-7
12.2.2	Connecting the Configuration Computer .....	12-8
12.2.3	Connecting the PLC .....	12-10
12.2.4	Connecting a Printer .....	12-12

<b>13</b>	<b>Commissioning</b>	<b>13-1</b>
13.1	Initial Startup	13-3
13.2	Recommissioning	13-4
13.3	Startup Behavior	13-8
13.4	Testing a Configuration in OFFLINE Mode	13-9
13.5	Testing the Configuration in Conjunction with the PLC	13-10

## Part IV DEVICE DESCRIPTION AND MAINTENANCE

<b>14</b>	<b>Unit Description TP27-6</b>	<b>14-1</b>
14.1	Dimensions	14-1
14.2	Operating elements	14-2
14.3	Connection elements	14-2
14.4	Communication options	14-3
<b>15</b>	<b>Unit Description TP27-10</b>	<b>15-1</b>
15.1	Dimensions	15-2
15.2	Operating elements	15-3
15.3	Connection Elements	15-3
15.4	Communication options	15-4
<b>16</b>	<b>Unit Description TP37</b>	<b>16-1</b>
16.1	Dimensions	16-2
16.2	Operating and Display Elements	16-3
16.3	Connection Elements	16-5
16.4	Communication options	16-6
<b>17</b>	<b>Options</b>	<b>17-1</b>
17.1	Direct Key Module	17-1
17.1.1	Installing the Direct Key Module	17-2
17.1.2	Connectors and Adjusters	17-4
17.2	Control Panel Interface	17-6
17.2.1	Installing the Control Panel Interface	17-7
17.2.2	Connectors	17-9
<b>18</b>	<b>Maintenance/Upkeep</b>	<b>18-1</b>
18.1	Cleaning the Screen	18-1
18.2	Replacing the Backup Battery	18-2
18.3	Replacing the Back-Lighting (TP37 only)	18-4

## Part V APPENDICES

<b>A</b>	<b>Technical Data</b> .....	<b>A-1</b>
A.1	Direct Key Module and Control Panel Interface .....	A-5
A.2	Chemical Resistance of the Touch Panel .....	A-8
<b>B</b>	<b>Interface Assignments</b> .....	<b>B-1</b>
<b>C</b>	<b>System Messages</b> .....	<b>C-1</b>
<b>D</b>	<b>SIMATIC HMI Documentation</b> .....	<b>D-1</b>
<b>E</b>	<b>ESD Guidelines</b> .....	<b>E-1</b>
	<b>Glossary</b> .....	<b>Glossary-1</b>
	<b>Index</b> .....	<b>Index-1</b>

# INTRODUCTION

- 1 Product Description**
- 2 Functionality**

# Part I



## Product Description

### Use of TP27 and TP37

By implementing the Touch Panels TP27 and TP37 operating statuses, current process values and faults in respect of a connected PLC can be graphically represented and the monitoring machine or system easily operated. This is made possible by using the Touch Panels which have of a number of standard functions for this purpose.

The method of display and operation of the Touch Panel can be customized using the ProTool configuration software to achieve optimum results in respect of process requirements.

The Touch Panel can be used to

- control and monitor the process by means of the menu system. In this way, setpoints can be entered in the form of values or by touching configured buttons, for example, or control positioning elements;
- display processes, machines and systems on full-graphic and semi-graphic screens;
- visualize event messages and alarm messages, in addition to process variables such as an output field, bar graph, trends or status display;
- intervene directly in the operation by means of the touch-sensitive screen.

### Touch screen

The Touch Panels TP27 and TP37 have standard keyboards. The device is operated intuitively by touching configured buttons and input fields on the touch-sensitive screen, referred to in this manual as the “touch screen”.

### Device variants

The TP27 can be supplied in a range of variations. One variant is equipped with a 6 inch display, available as monochrome and color versions. This variant is subsequently referred to as TP27-6.

The second variant is the TP27, equipped with a 10 inch, color display. This variant is subsequently referred to as TP27-10.

The TP37 is equipped with a 10 inch, color display.

### Installation possibilities

The Touch Panels TP27 and TP37 are installation units for use directly at the machine location. The degree of protection is high (front panel IP65), so the devices are suitable for use in hostile industrial environments.

**Set up data areas**

Before commissioning, the Touch Panel must be prepared for the task of visualizing data from the PLC. This means that data areas must be created in the PLC memory in your configuration which are then used by the Touch Panel to communicate with the PLC.

**Configuration using ProTool**

Graphics and texts to be displayed on the Touch Panel, together with the properties and functionalities of the touch-sensitive operating elements, must be created beforehand by means of a configuration computer (PC or PG) using the configuration software ProTool. Before downloading the configuration data to the Touch Panel, connect the configuration computer to the Touch Panel.

Once the configuration has been successfully downloaded, connect the Touch Panel to the PLC. The Touch Panel now communicates with the PLC and reacts to program execution on the PLC in accordance with the configured default values.

Figure 1-1 outlines the configuration and process control phase.

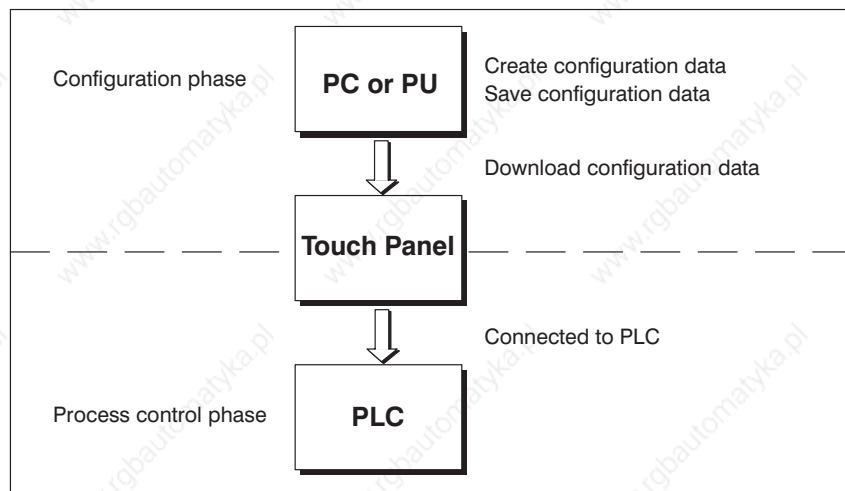

Figure 1-1 Configuration and process control phase

**Further information**

Information regarding configuration of the Touch Panel is provided in the *User's Guide ProTool – Configuring Graphics Displays*.

The *Communication User's Guide* provides information on connecting the Touch Panel to the PLC.

## 1.1 Visualizing and Controlling Processes

### Display and operating functions

The basic function of the Touch Panels TP27 and TP37 is the visualization of process statuses and the operation of processes. The following display and operating functions can be configured:

- screens
- input/output of process values
- bar graphs and trends
- text or graphic lists
- messages
- printout
- text
- help text
- recipes
- multiple languages
- password protection
- touch-sensitive operating elements.

### Screens

Logically related process data from the PLC can be compiled, displayed on a screen and individual parts of it modified. Screens may contain buttons, graphics, text and values.

The Touch Panels can display machines and systems as **full-graphics screens**. This makes it easier for the operator to find his way around.

### Input/Output

Numeric, alphanumeric and symbolic values can be entered via touch-sensitive input fields on the Touch Panel which are then transferred to the PLC. Current values of the PLC are displayed in output fields.

### Bar graphs and trend curves

Current process values can be output as numeric values, symbolic text, symbolic graphs or in the form of bar graphs and trend curves.

- **Bar graphs**  
represent a value as a rectangular area. Bar graphs can be used to display fill levels or quantities, for example.
- **Trends**  
display a value continuously. This display mode is useful when displaying values that vary with time, variations in temperature or pressure, for example.

### Symbol lists

Various graphic elements (bitmaps) or texts can be called into the display depending on the process status. In this way, for example, the current setting of a valve can be visualized on the Touch Panel by means of symbolic graphics or text can be modified according to the situation.

## Messages

Messages appear on the Touch Panel in plain text. The message text may also contain current process values. Incoming messages are stored in a message buffer together with their date and time.

- **Event messages**  
provide information and operating notes on current processes or machine states, for example  
Motor running at 3000 revs.
- **Alarm messages**  
provide information on critical machine states, for example  
Motor speed too high.

Alarm messages must be acknowledged on account of their urgency.

Messages are classified as event messages or alarm messages during configuration.

## Recording

All message events can be additionally recorded by being printed out in online mode on a connected printer. Messages which have accumulated in the event and alarm buffers can also be printed out.

## Texts

Texts identify individual parts of the screen in order to be able to assign the fields displayed to the process.

## Help texts

Help texts represent additional information and notes for the operator, which can be configured, in respect of the screens, input fields and messages. The help text relating to an alarm message, for example, may display information on the cause of a malfunction and how to clear it.

## Recipe

Complete machine data records can be stored as recipes in a Touch Panel. A recipe defines the data structure in a configuration. Data is assigned to the configured structure on the Touch Panel.

The purpose of recipes is to transfer several items of data collectively to the PLC. In this respect, it is immaterial whether actual recipes, specifications of quantities, distances to be traversed or temperature variations are involved.

## Multiple languages

Message texts, texts in screens, help texts, system messages and button labels may be stored in three languages simultaneously in the Touch Panel and selected online.

## Password protection

The password protection feature prevents unauthorized operations of the Touch Panel. Different passwords can be assigned to different users or user groups, thus authorizing or prohibiting access to specific control functions by assigning different password levels.

## Operating elements

Direct intervention in the process operation is possible by using the touch-sensitive buttons and input fields on the Touch Panel screen.

The structure of the Touch Panel user interface can be configured to suit individual needs. Simply adjust the number, characteristics, positions and functionality of the operating elements for the specific application.

## 1.2 The Touch Panels at a Glance

Hardware		TP27-6 Monochrome	TP27-6 Color	TP27-10 Color	TP37 Color
<b>Models</b>	Monochrome display Color display	✓ –	– ✓	– ✓	– ✓
<b>Display</b>	Type	STN <sup>1)</sup> -LCD			TFT <sup>2)</sup> -LCD
	Size	5.7"		10.3"	
	Touch screen	Matrix 20 x 15		Analog, resistive	
	Resolution (pixels)	320 x 240		640 x 480	
	Colors	8 Grey shades	8		
	Back-lighting	✓			
<b>Indicators</b>	LEDs for	–			TP on Temperature limit value reached Write/read access to memory card
<b>Interfaces</b>	Serial interface to connection From PLC, PC/PU, printer	2 x RS232/TTY (active/passive) 1 x RS422/RS485			2 x RS232/TTY (active/passive) 1 x RS422/RS485 1 x TTY (passive) / RS422/RS485
	Parallel interface for connecting a printer	–			1 x TTL (Centronics)
<sup>1)</sup> passive drive <sup>2)</sup> active drive					

Hardware		TP27-6 Monochrome	TP27-6 Color	TP27-10 Color	TP37 Color
<b>Processor</b>	Type	80486			Pentium
	Clock	33 MHz			100 MHz
<b>Memory</b>	Flash EPROM for firmware and user data	1 MB		2 MB	
	Main memory (DRAM)	2 MB		4 MB	8 MB
<b>Special features</b>	Hardware clock (battery-backed)	✓			
	Relay output for temperature monitoring	-			✓
	Module slot for PCMCIA/Jeida cards	✓		Slot B (Slot A not used)	

Hardware		TP27M-6	TP27C-6	TP27-10	TP37
<b>direct key module</b>	Digital outputs, drive via configurable ports	8		16	
<b>Control Panel Interface<sup>1)</sup></b>	Digital inputs/outputs	16		16/32	
<sup>1)</sup> usable only in conjunction with SIMATIC S7 and Profibus-DP					

**Further information**

Detailed information regarding the technical data of the Touch Panels TP27 and TP37 is provided in the Appendix A of this manual.

# 2

## Functionality

The table below summarizes the functions of the Touch Panels TP27 and TP37. The values quoted are the maximum values which can be managed by the Touch Panels. The values are limited by the size of the user memory.

Functions		TP27-6	TP27-10	TP37
Event messages	Number	2000		
	Display	On message line/message window		
	View all waiting messages	on message page		
	Length message text per line	35 characters	70 characters	
	Lines per message	2	1	
	Process values in message text	8		
Alarm messages	Number	2000		
	Display	In message window		
	Display type	First value/last value, selectable		
	View all waiting messages	On message page		
	Length message text per line	35 characters	70 characters	
	Lines per message	2	1	
	Process values in message text	8		
	Acknowledge individual alarm messages	✓		
	Acknowledge several alarm messages simultaneously	16 acknowledgment groups		
Message logging	Output to printer	✓		
Message buffer	Capacity	512 message events		
	View buffered event/alarm messages	✓		
	Delete	✓		
	Buffer overflow warning	✓		
	Automatic printout on buffer overflow	✓		
	Message events queued simultaneously (max.)			
	• Event messages	500		
	• Alarm messages	250		

Functions		TP27-6	TP27-10	TP37
Message acquisition	Time of occurrence	Date and time		
	Message events	Arrive, depart, acknowledge		
Screens	View	✓		
	Printout	✓		
	Static screen elements	Pixel graphics Text Character graphics		
	Input/Output elements	Input fields Output fields Combined input/output fields Symbolic input fields Symbolic output fields Bar graphs Trends Buttons light indicators		
	Operator prompting	Buttons (dynamically modifiable) light indicators Symbolic input Symbolic output		
	Fixed window	✓		
	Limit value monitoring	Inputs/outputs	✓	
Bar graphs and trends		✓		
Text attributes	Display	Flashing, inverse, underscore		
	Printer (messages)	Bold, underscore		
Help text	Lines/characters	7/35		
	For messages	✓		
	For input fields	✓		
	For screens	✓		
Print functions	Hardcopy of display contents (screen dump) • character mode (ASCII) • graphics mode	✓ ✓		
	Direct message logging	✓		
	Screen printout in character mode (ASCII)	✓		
	Graphics printout in graphics mode	✓		
Password protection	Number of passwords	50		
	Password levels	10 (0...9)		

Functions		TP27-6	TP27-10	TP37
Recipes	Number	255		
	Data records per recipe	500		
	Entries per data record	500 3000 (SIMATIC S7)		
	Save (create) data records	PLCTP → Data medium		
	Load data records	Data medium → TP/PLC		
	Delete data records	On data medium		
	Modify (edit) data records	On data medium		
	Transfer current values	PLC → TP TP → PLC		
	Transfer data records	Data Medium → TP TP → Data Medium		
	Record sets	✓		
Backup	Backup/restore for memory card	–	✓	
Online language change	Number of languages	3		
	Loadable character sets per language	3		
	Language-independent character set (incl. character-graphic characters)	1		
	Character size in pixels	8 x 8 to 64 x 64		
Display	Blank screen	✓		
	Contrast	✓	–	
	Audio volume adjustable	✓	✓ <sup>1)</sup>	
	Calibration	not necessary	✓	
<sup>1)</sup> Can only be switched on/off				

Functions		TP27-6	TP27-10	TP37
Communication	<b>SIMATIC S5</b> – AS511 – FAP – PROFIBUS-DP		✓ ✓ ✓	
	<b>SIMATIC S7/M7</b> – PPI – MPI – PROFIBUS-DP		✓ ✓ ✓	
	<b>SIMATIC 500/505</b> – NITP		✓	
	<b>NATIVE driver</b> – AEG/Modicon (Modbus) – Allen Bradley (DF1)O – Mitsubishi (FX) – Omron – Telemecanique (Adjust, Uni-Telway)		✓ ✓ ✓ ✓ ✓	

# **FUNCTIONS OF THE TOUCH PANELS**

# **Part II**

- 3 General Operation**
- 4 Screens**
- 5 Password Protection**
- 6 Messages**
- 7 Printing**
- 8 Recipes**
- 9 Storing and Loading Data**
- 10 Status/Force Tag Using the TP**
- 11 System Settings**



## General Operation

### Operating concept

Using the Touch Panel screen, it is possible to observe the operating status of the machine or system being monitored and, at the same time, to intervene directly in the process running simply by touching the buttons and input fields displayed.

Operation of the Touch Panels TP27 and TP37 is intuitive to a large extent, because

- operating elements can be positioned where they belong, from a functional point of view,
- labeling of visible buttons is dynamic; in other words, labeling can be changed online, according to the language required, or language-independent bitmaps can be assigned to the buttons, for example,
- any sections of the system or process screen are rendered operable by superimposing invisible buttons
- virtual keys for cursor functions and value input only appear when they can actually be used: In input windows.

### Screen partitioning

A screen occupies the entire display. An example of screen partitioning on the TP37 display containing several open windows is illustrated in figure 3-1. The TP27-6 has a smaller display, so that the operating elements are cascaded (overlap).

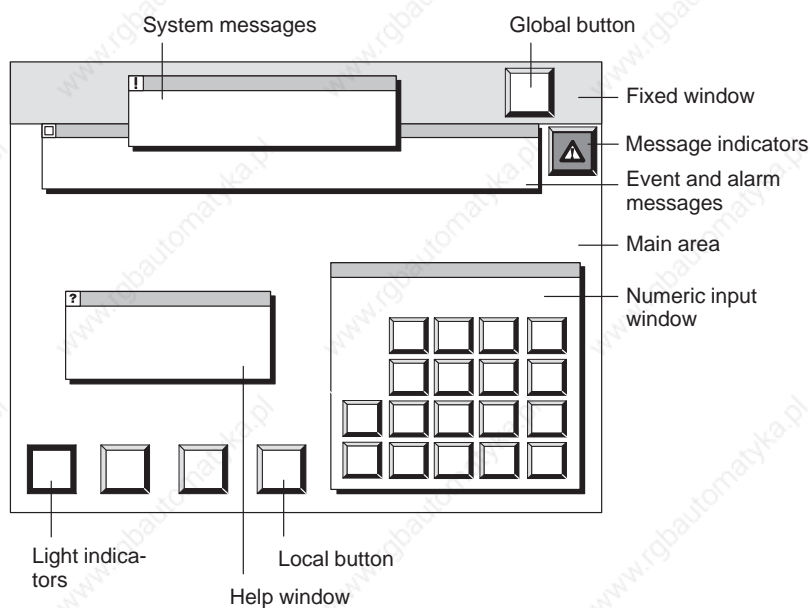

Figure 3-1 Screen partitioning on the TP37 (example)

**Fixed window**

The fixed window can be used to display important process magnitudes or date and time, since the contents are not affected by the screen currently open.

**Main area**

The main area comprises the entire display. It is superimposed by all other areas (fixed window, message window etc.). The main area contains the current contents of the screen that is currently open.

**Buttons**

The functions configured for the buttons have a **local** significance in the main area. Buttons of local significance initiate different actions from screen to screen on the Touch Panel or on the PLC, such as enabling and disabling Select Screen, Language Switch or message logging. If buttons are positioned in the fixed window, their functions are available **globally**. This means, for example, that the current screen can be printed (Print Screen) or the system returned to the main screen from any operating situation.

Buttons may have text or graphic labels. Examples:

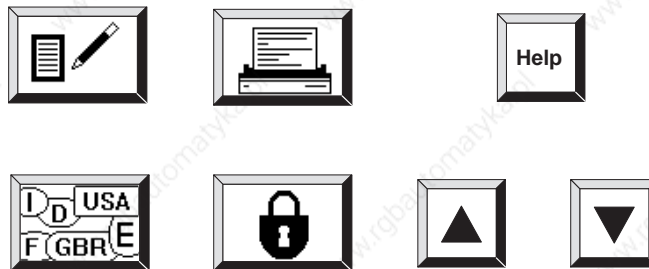

**Light indicators**

Light indicators are configurable, non-operable display elements. A light indicator signals the status of a defined bit by assigning dynamic attributes, for example a change of color or flashing text.

No function is assigned to a light indicator. Light indicators have thin borders to distinguish them from user-operable buttons.

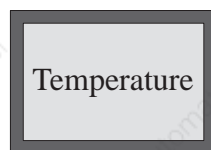

Light indicators can be positioned locally in the main area or globally in the fixed window.

**Window positions**

**Input window:**

Regardless of the absolute position of the selected field, the input window always appears at the bottom right of the screen. After clicking on the top edge of the window, it skips to the opposite edge of the screen (only with TP37 and TP27-10)

**Message window:**

The system message window appears in the upper part of the screen. The position of the event message window can be configured.

**Help window:**

The window for displaying configured Help texts is appears at the bottom left.

**Open windows**

Several windows can be opened simultaneously on the Touch Panel, e.g. an input window in the main area, an event message window, an alarm window and a help window (figure 3-1). As soon as one of these windows is opened, the input elements in the main area and fixed window can no longer be accessed. All visible elements in the input and message windows remain accessible.

**Message indicator**

The message indicator indicates that alarm messages have been received.

Not flashing: Alarm messages have been received which have been acknowledged.

Flashing: Alarm messages have been received which have not been acknowledged.

## 3.1 Operating Touch Elements

### Definition

Touch elements are contact-sensitive operating elements on the screen of the Touch Panel, such as buttons, input fields, message windows and help windows. Their operation is basically no different from pressing conventional keys. Touch elements are operated by lightly touching them with your finger or a pointer.

---

### Note

- Never use pointed or sharp instruments to operate the Touch Panel to prevent damage to the plastic surface of the touch screen.
  - Touch only one point of the **Touch Panel** screen at a time. Do not touch several touch elements simultaneously. If you do, an unintended action may be initiated.
- 

### Triggering functions

A function assigned to a button is normally triggered when the button is touched. With some functions, it is possible to define the configuration so that the function is not triggered until the button is released or its outlines remain while being touched, e.g. the “Set Bit” function or the keypad in the input window for numerical values. If the button has a repeater, keep touching the button as long as the function in question is to be repeated.

Not more than one touch element is activated per touch. Where an operating function has still not been completed, e.g. entering a value, any successive attempt to trigger a similar function is refused and a system message to this effect issued. Similar functions in this respect are Enter Setpoint and Edit Data Record, for example.

### Operation acknowledgement

When the Touch Panel detects contact on a valid touch element, it responds with a visual or acoustic acknowledgement. An acknowledgment is independent of communication with the PLC. It is not an indication of the required action actually having been executed.

### Acoustic acknowledgement

An acoustic signal is issued as long as the touch element is touched. The signal tone can be enabled and disabled by means of the *System Settings* standard screen (TP37) and the volume adjusted (TP27), see chapter 11.

## Visual acknowledgement

The type of visual operation acknowledgement is dependent on the operating element touched.

- **Visible buttons**

The border color of the button touched changes:

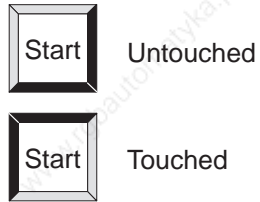

- **Input fields**

The foreground and background colors of a touched input field are interchanged. The change of color remains in effect until input is terminated or canceled.

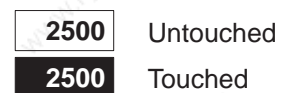

- **Message windows and invisible buttons**

A pointing hand, similar to that illustrated here, appears to the top left of the operating element touched:



If the element touched is at the top border of the screen, the pointing hand appears to the right and beneath the element in question.

## 3.2 Entering Values

### Principle

Values can be entered in the input fields and combined input/output fields which are then transferred to the PLC. To do so, touch the corresponding field. The foreground and background colors of a selected input field are interchanged. Depending on the display type configured, the system opens one of the input windows for

- numeric inputs,
- alphanumeric inputs,
- symbolic inputs.

The input window is closed following a valid input. The foreground and background colors of the field being edited are reset and the new value is applied to the input field.

### 3.2.1 Entering Numerical Values

#### Input window

Enter numbers in the fields configured for pure numeric input, digit for digit, using the numeric keypad of the input window illustrated in figure 3-2.

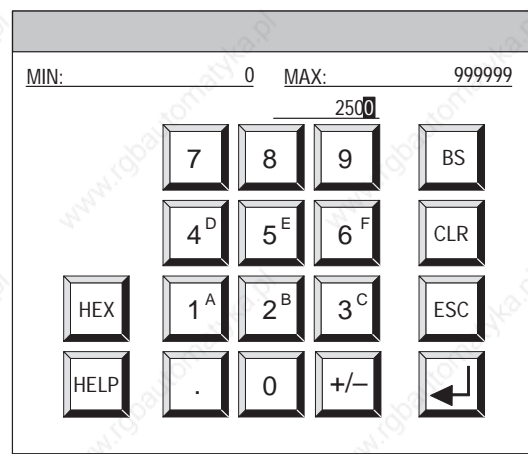











Figure 3-2 Window for entering numeric values

**Meanings of buttons**

Button	Function	Purpose
	<b>Enter digits</b>	Enter digits 0 to 9.
	<b>Enter hexadecimal numbers</b>	Enter the hexadecimal numbers A to F (after pressing HEX).
	<b>Change sign</b>	Change sign from + to - and back.
	<b>Enter decimal point</b>	Enter decimal point or comma.
	<b>Hexadecimal mode</b>	Change numbers 1 to 6 to characters A to F.
	<b>Display help text (Help)</b>	Call Help text for the current input field. The button is not displayed unless the corresponding Help text is configured.
	<b>Delete character (Backspace)</b>	Delete character shown in reverse video in the input line.
	<b>Delete input line (Clear)</b>	Delete all characters in the line, i.e. clear the input line.
	<b>Cancel (Escape)</b>	Discard input and close window.
	<b>Enter</b>	Confirm input and close window.

**Entering a value**

Entries in numeric input fields begin aligned to the right. Entered digits are moved to the left (pocket calculator format).

The current input position is displayed in reversed background/foreground colors. Invalid characters, e.g. numbers greater than 1 in binary format, are rejected with an error message. If the entry is too long, the last character entered is overwritten.

If limit values have been configured for the specifications to be entered, they appear at the top edge of the input window. MIN indicates the lower limit value and MAX the upper.

**Hexadecimal mode**

In order to enter the hexadecimal digits A to F, press the button HEX. An “h” appears at the current input position. Press one of the buttons 1 to 6. The Touch Panel reverts to decimal mode after each character.

**Help text**

After pressing the HELP button, the help text configured for the relevant input field appears. See figure 3-5 on page 3-11 for an example.

**Terminate input**

Confirm the value entered by pressing the ENTER button, press ESC to cancel the input process. The window is closed in both cases.

### 3.2.2 Entering Alphanumeric Values

**Input window**

Enter numbers in the fields configured for alphanumeric input, character for character, using the alphanumeric keypad. Figure 3-3 illustrates the language-independent keyboard template for the normal level. The keyboard template for the Shift level of the alphanumeric keyboard varies according to the language.

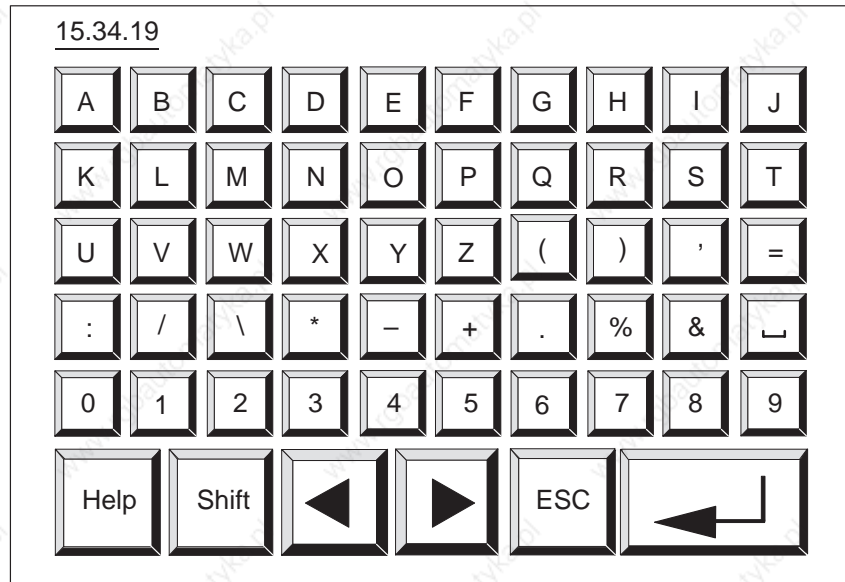







Figure 3-3 Entering alphanumeric values at the language-independent normal level

**Meanings of buttons**

Button	Function	Purpose
A ... 9	Enter characters	Enter the characters using either the normal or Shift level of the keyboard.
HELP	Display help text	Call help text for the current input field. The button is not displayed unless the corresponding help text is configured.

Button	Function	Purpose
	<b>Keyboard levels</b>	Activate/Deactivate the keyboard Shift level from normal level.
	<b>Cursor left</b>	Cursor moves one character to the left.
	<b>Cursor right</b>	Cursor moves one character to the right.
	<b>Cancel (Escape)</b>	Discard input and close window.
	<b>Enter</b>	Confirm input and close window.

### Entering a value

Entries in alphanumeric input fields begin aligned to the left. Every time a character is entered, the cursor moves to the right to the next input position. Characters at the input position are overwritten.

The current input position is displayed in reversed background/foreground colors. Invalid characters (e.g. values greater than 23 for the hour value in time) are rejected and an error message issued. If the entry is too long, the last character entered is overwritten.

If a value already exists in the alphanumeric input field, this appears in inverse colors when the field is activated and deleted on beginning a new entry. In order to edit the old value, one of the cursor keys must be pressed as the first entry. On pressing CURSOR LEFT, the cursor remains on the first character, and on pressing CURSOR RIGHT it skips to the second character. In this case, the value is no longer displayed in inverse colors and can be edited.

### Help text

After pressing the HELP button the help text configured for the relevant input field appears. See figure 3-5 on page 3-11 for an example.

### Keyboard levels

The alphanumeric keyboard has two levels:

- Normal level: (see figure 3-3) is the same in all languages.
- Shift level: the keyboard template varies from language to language.

Use SHIFT to toggle between the two levels.

### Terminate input

Confirm the value entered by pressing the ENTER button, press ESC to cancel the input process. The window is closed in both cases.

### 3.2.3 Entering Symbolic Values

#### Input window

Text is entered and displayed in symbolic input fields instead of a value. Select the text from the configured text list. Figure 3-4 depicts the input window.

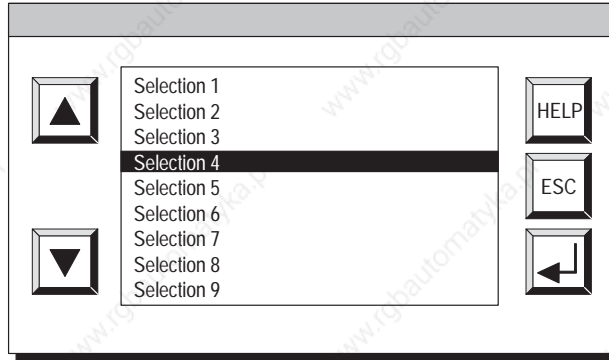







Figure 3-4 Window for entering symbolic values

#### Meanings of buttons

Button	Function	Purpose
 	<b>Scroll (Cursor)</b>	Scroll up and down one line at a time through the text list.
	<b>Display Help text</b>	Call Help text for the current input field. The button is not displayed unless the corresponding Help text is configured.
	<b>Cancel (Escape)</b>	Discard selection and close window.
	<b>Enter</b>	Confirm selection and close window.

#### Select value

Scroll through the text list using the cursor buttons or point directly to the entry required. The current selection is displayed in reversed screen colors.

The cursor buttons have a repeat function. When pressed, their scroll function is repeated after a short delay and continues until the button is released.

#### Help text

After pressing the HELP button the help text configured for the relevant input field appears. See figure 3-5 on page 3-11 for an example.

#### Terminate input

Confirm the selection by pressing the ENTER button, press ESC to cancel the input process. The window is closed in either case.

### 3.3 Help Text

#### Purpose

Help texts are created during configuration using ProTool and provide additional information on the respective subject in the language selected on the Touch Panel. Help texts can be configured for

- event and alarm messages
- screens
- input and combined input/output fields.

Help texts can provide information to the user on the permissible range of values for the input field selected, for instance. Help texts referring to an alarm message may, for example, contain supplementary details on possible causes and on rectifying the problem.

#### Calling help texts

The configured help text can be called to the screen by accessing the relevant input field and pressing the HELP button. Figure 3-5 depicts an example of the output window.

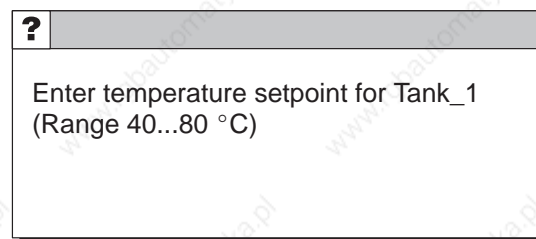

Figure 3-5 Window with help text (example)

Touch the window to close it.



## Screens

### Process control and monitoring

Processes (e.g. a processing machine or mixing station) are displayed on and can be influenced by screens which appear on the Touch Panel. These screens are created during configuration with ProTool for specific applications.

Logically related process values are acquired on screens and thus provide an overview of a process or a system. Apart from this graphic mapping of processes, screens provide an opportunity of entering new process values and thus of controlling the process.

### 4.1 Screen Elements

#### Screen sections

Various screen elements are used to display and control screens:

- text
- graphics
- character graphics
- input fields for process values
- output fields for process values
- combined input/output fields
- bar graphs
- trends
- text or graphic lists
- buttons,
- light indicators.

The different screen elements are presented on the basis of the following examples.

#### Example

Part of the contents of various tanks are filled and mixed in a mixing unit of a fruit juice mixing system. The liquid levels in the tanks and in the mixer are displayed. The intake valves can be opened and closed by means of operator input on the Touch Panel. The motor for the mixer can be turned on and off in a similar manner.

Figure 4-1 illustrates how the configured screen may appear on the Touch Panel.

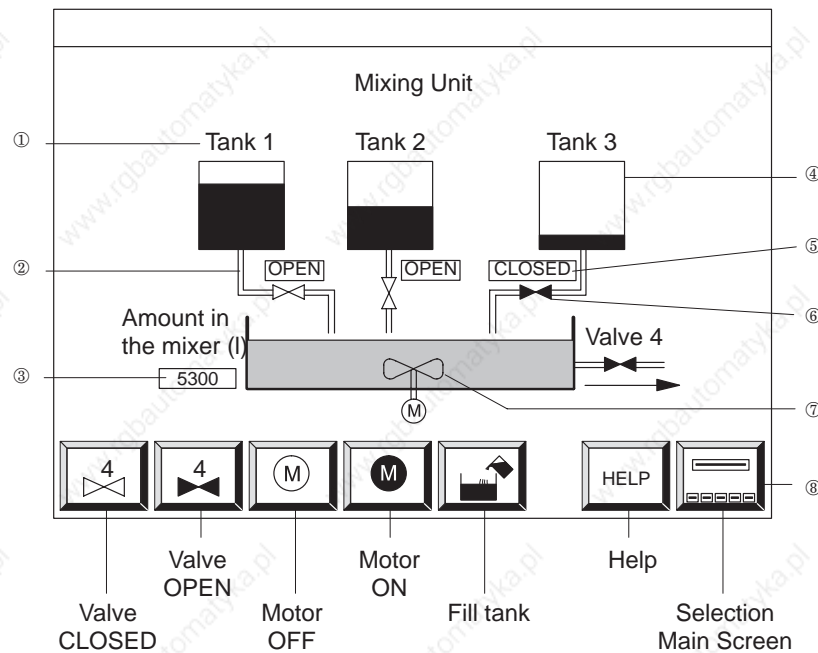

- ① Text
- ② Character graphic
- ③ Numeric output field
- ④ Bar graph (tank filling)
- ⑤ Symbolic input field for opening and closing the valve
- ⑥ Symbolic graphic indicates the valve status graphically (open/closed)
- ⑦ Graphic
- ⑧ Button

Figure 4-1 Configured screen for a mixing unit (example)

### Selecting a screen

Screens can be viewed, processed and printed via the Touch Panel. Before these actions can be performed, however, the screen has to be selected. Select a screen by means of a

- **Button**  
The screen set in the configuration is opened by touching a button.
- **Input field**  
Enter the number of the screen to be opened or select the name of the screen from the pick list, if applicable.
- **PLC job**  
The PLC calls a screen on the Touch Panel, depending on the status of the process or the system.

## 4.2 Standard Screens

### Purpose

A standard configuration containing standard screens is supplied with the configuration software ProTool for the respective Touch Panel. The functions needed for basic operation of the Touch Panel have been implemented in the standard screens. They include, for example, Call Message Buffer, Edit Passwords and Change Parameters Online. The individual functions are described in this manual on the basis of the standard screens.

Process-specific implementation, such as event messages or screens for the process, are not included in the standard screens.

### Main screen

The standard screens are called in via buttons on the main screen. The following screen provides an example of the main screen of the TP37. The main screen of the TP27 contains the same buttons.

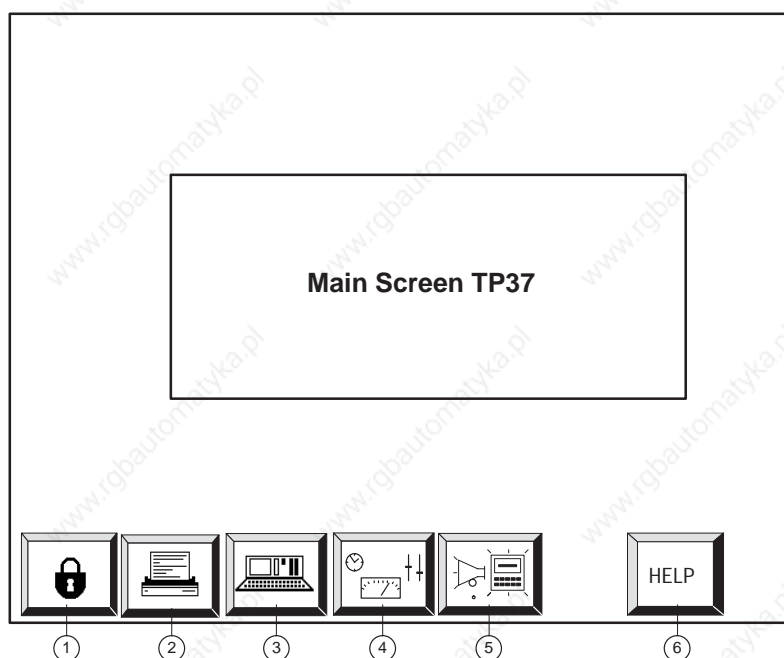

- ① Edit Password (chapter 5)
- ② Printer Settings (chapter 7)
- ③ System Settings (chapter 11)
- ④ Status/Control Tag (chapter 10)
- ⑤ Messages (chapter 6)
- ⑥ Help Text (section 3.3)

Figure 4-2 illustrates the standard screen hierarchy. Detailed information on the functions and operation of standard screens is provided in the corresponding sections of this manual.

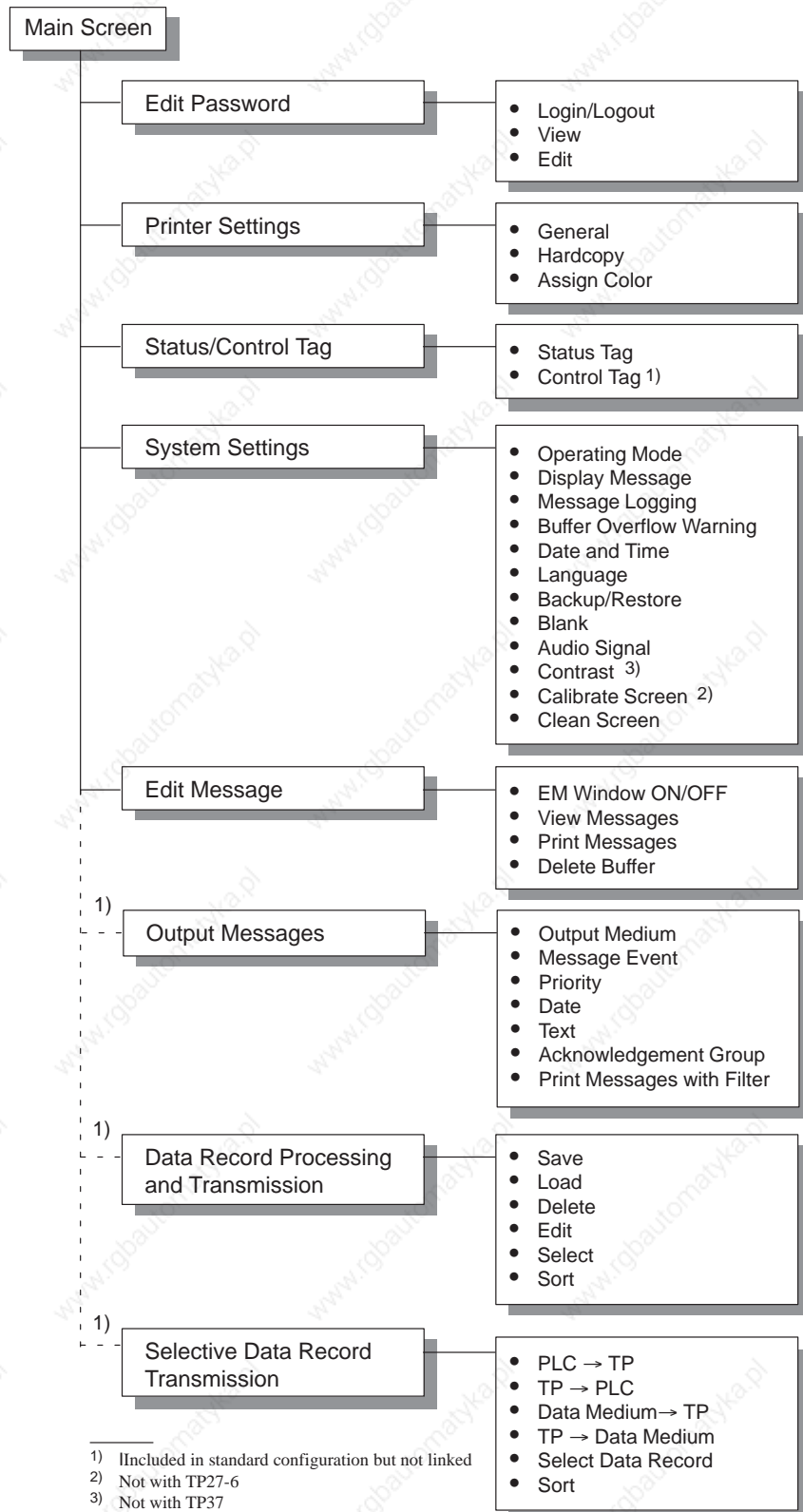

Figure 4-2 Standard screen hierarchy

**Calling functions**

Functions are called in on the Touch Panel by means of configured buttons. To prevent unauthorized access, some functions have to be protected beforehand by means of a password at a specific password level (see chapter 5).

**Calling Help texts**

Configured help texts can be called int the standard screens by pressing the button shown here.





## Password Protection

**Access protection** Password protection can be configured for buttons and input fields to prevent operation of the Touch Panel by unauthorized personnel.

### 5.1 Password Level and Access Permissions

#### Password hierarchy

During the configuration phase with ProTool, the configurer assigns the buttons and input fields hierarchically ascending password levels from 0 to 9. When a password is assigned to an individual user or to a whole user group, the permission to execute functions at a specific level is assigned simultaneously.

After logging in with a password of a specific password level on the Touch Panel, permission to execute functions is granted at that password level and functions at lower levels.

#### Password level 0

If a function is configured with password level 0, no password need be entered in order to execute this function. The functions assigned at this level, the lowest in the hierarchy, have little or no effect on operation. These functions normally do not have input options; one example is Open Message Pages.

To call a password level 0 function, you do not have to enter a password. If you call a function that is assigned to a higher level, the Touch Panel will prompt you to enter a password.

#### Password level 1 – 8

Levels 1 to 8 should be assigned by the configurer according to the significance of the respective function. The supervisor (superuser) is responsible for assigning a password level to a password as part of his password management duties.

#### Password level 9

Only the superuser has the rights to execute functions assigned password level 9. The superuser has access to all the functions of the Touch Panel.

Only the superuser is authorized to perform password management on the Touch Panel. Password management involves assigning and changing passwords.

**Superuser password**

The superuser password is defined during configuration. The default value in the standard configuration is “100”. This setting can be changed using the Touch Panel.

**Passwords from levels 1 to 8**

The passwords from levels 1 to 8 are not assigned during configuration but during operation by using the Touch Panel. Use the standard screen *Password Processing* to do this (refer to chapter 5.3).

**Format**

The password must be a minimum of 1 character and may be a maximum of 8. Alphanumeric characters are permissible. Leading zeroes are not permitted.

**Standard screen**

The *Password Processing* standard screen (figure 5-1) provides the following functions:

- Login/logout on the Touch Panel,
- Change and delete passwords,
- View password list.

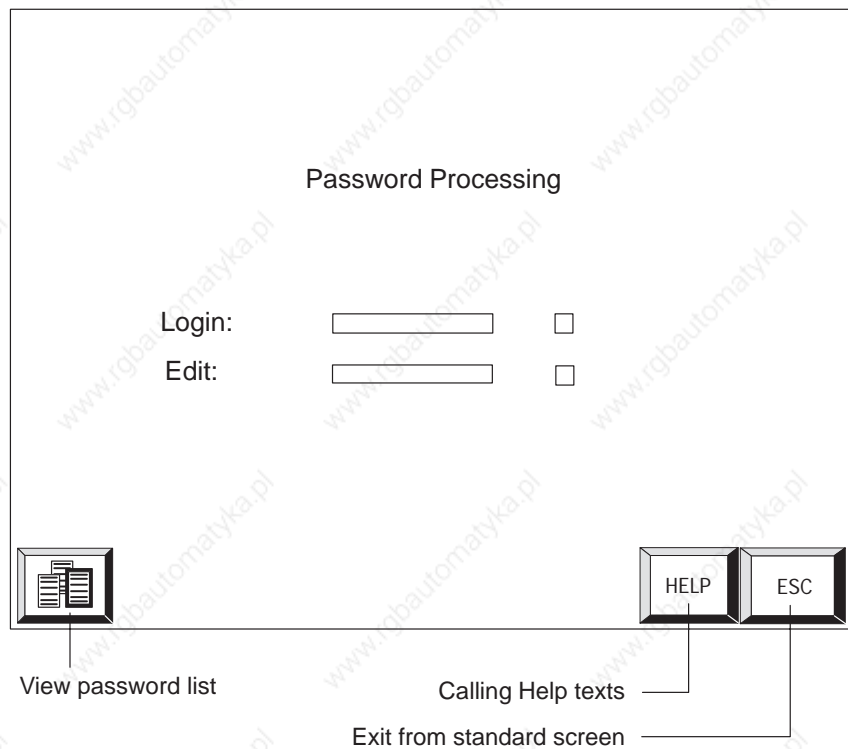

Figure 5-1 Standard screen *Password Processing*



## 5.2 Login/Logout on the Touch Panel

### Login

Login on the Touch Panel

- using the *Password Processing* standard screen
- by calling a function for which the current password level is too low. In this case, the Touch Panel automatically requests a password.

### Logging in on standard screen

Step	Action	Result
1	Call the standard screen <i>Password Processing</i> .	The standard screen is displayed (figure 5-1).
2	Touch the <i>Login</i> input field.	The password input window opens (figure 5-2). The possible input positions are marked by hash characters (#).
3	Enter your password by means of the keypad.	Input commences flush left. Each character entered is represented by an asterisk (*).
4	Confirm the entry by pressing  Or cancel the input by pressing 	The input window is closed. If the password is valid, the corresponding password level is displayed next to the <i>Login</i> input field.

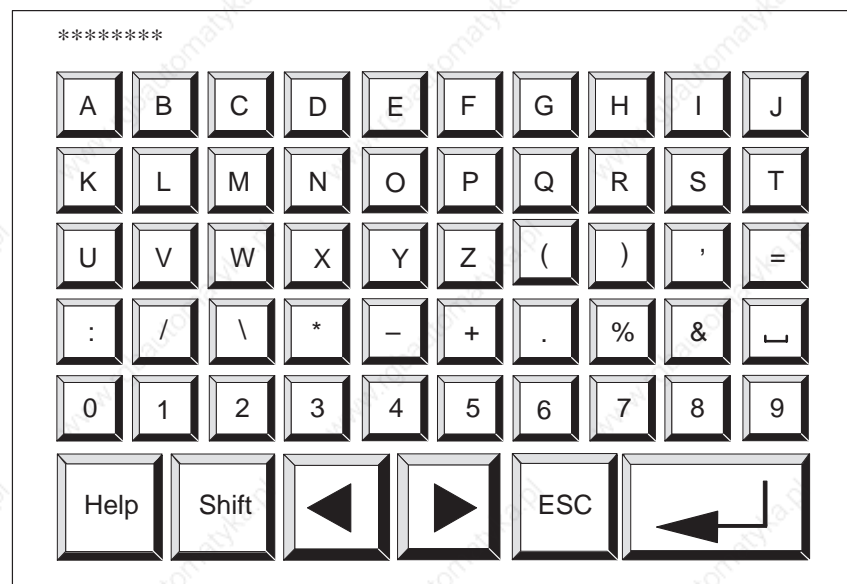

Figure 5-2 Window for entering the password (example TP27-6)

**Automatic call**

If a password level higher than the current one is required for a button or an input field, the Touch Panel automatically requests the entry of an appropriate password beforehand.

**Logout**

If the Touch Panel screen is not touched within a configured time, the current password level is automatically reset to zero. This means that unauthorized persons cannot gain access while the Touch Panel is unattended.

It is also possible to log out from the Touch Panel by using the *Password Processing* standard screen. Carry out the following steps to do this:

**Logging off on standard screen**

Step	Action	Result
1	Call the standard screen <i>Password Processing</i> .	The standard screen is displayed (figure 5-1).
2	Touch the <i>Login</i> input field.	The password input window opens (figure 5-2).
3	Enter an invalid password and confirm by pressing 	Once it has been applied, the effective current password level is 0.

## 5.3 Password Management

### Functions

The *Password Processing* standard screen provides the following functions for password management:



- create passwords and assign password levels,
- delete passwords,
- change passwords and password levels,
- view password list.

These functions can only be called in password level 9 (exception: view password list). Therefore, log in beforehand by means of the *Login* input field using the superuser password.



### Creating a password

A maximum of 50 different passwords can be set up on the Touch Panel. Password level 9 (superuser) can be assigned once only.

Carry out the following steps to assign a password and password level:

Step	Action	Result
1	Touch the <i>Edit</i> input field.	The password input window opens.
2	Enter a password that has not been previously issued and confirm it by pressing 	The password is transferred to the <i>Edit</i> field.
3	Touch the input field behind the <i>Edit</i> field.	The password level input window opens.
4	Enter a password level between 1 and 8 and confirm by pressing 	The new password is saved on the Touch Panel and protected even in the event of a power failure.

**Deleting a password**

Step	Action	Result
1	Touch the <i>Edit</i> input field.	The password input window opens.
2	Enter the password to be deleted in the input field <i>Edit</i> and confirm by pressing 	If the password level in the adjacent input field is set to 0, the password has been deleted.
3	Otherwise, touch the input field behind the <i>Edit</i> field.	The password level input window opens.
4	Overwrite the password level with 0 and confirm by pressing 	Once it has been transferred, the password is deleted.



**Changing a password**

It is not possible to change a password on the Touch Panel directly. To change a password, the existing one must be deleted and a new one entered.

Exception:

The superuser password can be changed by overwriting it directly.

**Changing password levels**

Step	Action	Result
1	Touch the <i>Edit</i> input field.	The password input window opens.
2	Enter the password to be assigned a new level in the input field <i>Edit</i> and confirm by pressing 	The password level of the password entered appears in the input field behind the field <i>Edit</i> .
3	Touch the input field behind the <i>Edit</i> field.	The password level input window opens.
4	Overwrite the password level with a new value and confirm pressing 	Once it has been transferred, the new level is assigned to the password.





### Viewing the password list

The password list contains all the passwords set up on the Touch Panel. The only passwords displayed are those with a password level lower or equal to that with which the user logged in on the Touch Panel. The supervisor password is not displayed.

Call in the password list by pressing the button



### Action

Step	Action	Result
1	Touch the button 	The password list window opens (figure 5-3).
2	Use the arrow keys, if necessary, to scroll through the list  	The password and password level at the current cursor position are displayed in inverse screen colors.
3	Terminate the action by pressing 	The password list window is closed.

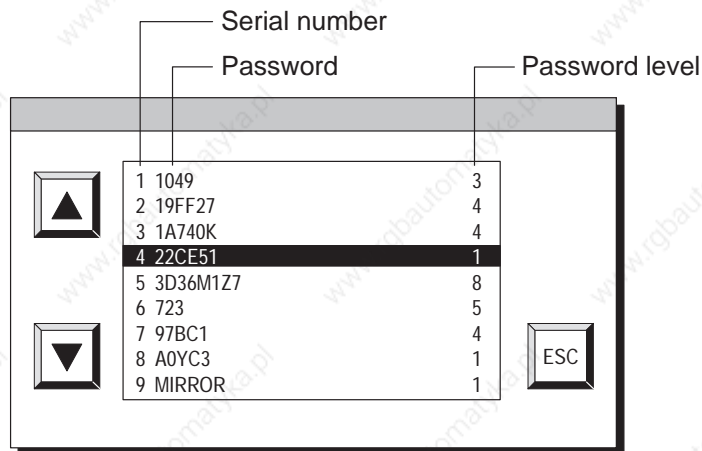

Figure 5-3 Password list



# Messages

## Overview

Messages on the Touch Panel indicate events and statuses related to control processes. A message consists of static text, at least. It may also contain tags.

The following types of message are displayed in plain text on the Touch Panel.

- event messages
- alarm messages
- system messages

Once issued, alarm messages and event messages are stored on the Touch Panel in battery-backed message buffers, so they are protected against power failures. Messages in the buffers may be called to the display and logged on the attached printer. The Touch Panel can still be operated when messages are waiting to be displayed.

## Message states

Alarm and event messages may contain the following information:

- **Arrived:**  
Denotes the occurrence of a message.
- **Cleared:**  
The reason for the message no longer exists.
- **Acknowledged** (alarm messages only):  
The message has been noted by the operator or the PLC, acknowledged and confirmed.

A message status is accurately timed by the Touch Panel when it is recorded and indicated when a message page or buffer is displayed.

## 6.1 Types of Message

### Event and alarm messages

Event and alarm messages must be configured. Event messages indicate a status in the process, whereas alarm messages indicate faults or errors. Event messages and alarm messages are issued by the PLC. Alarm messages have to be acknowledged on account of their significance.

### System messages

System messages are triggered by the Touch Panel. They do not have to be configured. System messages provide information on operating status of the Touch Panel and on maloperations or malfunctions in communication.

### 6.1.1 Event Messages and Alarm Messages

#### Definition

The configuration defines whether a process status is indicated by an event message or alarm message.

Messages referring to regular sequences of events or states should be categorized as event messages; for example

```

 0000031 10:53:27 04.04.97 11
Mixing operation completed
Filing level in mixer: 5000 l
    
```

Messages relating to disturbances of the process or status should be categorized as alarm messages; for example

```

 0000017 10:59:53 04.04.97 AGR 04 3
Bottling operation aborted
Bottling valve closed
                  
    
```

Alarm messages have to be acknowledged on account of their urgency. By doing so, the operator confirms that he has taken note of the alarm message. Alarm messages can also be acknowledged by the PLC.

Operational hints can be configured as event messages or alarm messages, in addition to status messages. If, for example, the machine operator wishes to start the filling operation but has forgotten to open the bottling valve on the mixer, he can be requested to rectify the error by means of an event message; for example

```

 0000037 11:01:02 04.04.97 11
Open bottling valve
    
```

## Presentation

Alarm and event messages can be configured so that text components flash in order to distinguish them from other message texts.

Messages may contain text and tag fields. Tag fields display current PLC actual values in numeric form.

## Standby message

A sub-category of the event message is the standby message. The standby message is the event message number 0. It is displayed when there are no event messages on the Touch Panel.

## Display mode

A current event or alarm message can be displayed in either a message line or message window. One of the following combinations can be defined in the configuration:

- **Window/window**

Event messages and alarm messages are displayed in separate windows.

The alarm message window is opened automatically when an alarm message arrives. When the alarm message is acknowledged, the alarm message window disappears.

The event message window can be opened only by activating a button.

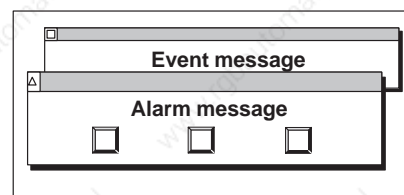

- **Window/line**

An event message is displayed in the message line, whereas an alarm message is displayed in the message window. The alarm message window is opened automatically when an alarm message occurs. When an alarm message is acknowledged, the alarm message window disappears if no other alarm messages are waiting.

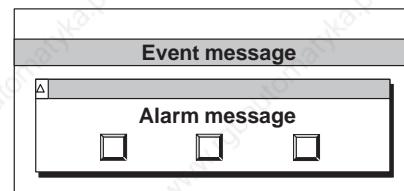

- **Window/hide**

An alarm message is displayed in the message window. Event messages are not displayed.

When the alarm message is acknowledged, the alarm message window is closed.

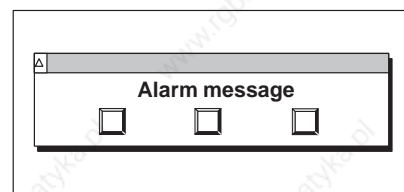

**Message line**

When a message line has been configured it is always displayed, regardless of the screen selected. Only the latest message is displayed in the message line.

**Message window**

Messages in the configured message window contain additional information on the message, such as message number and date/time the message arrived. The alarm message window has extra buttons.

**Alarm message window:**

The alarm message window (figure 6-1) automatically appears whenever an alarm message is issued.

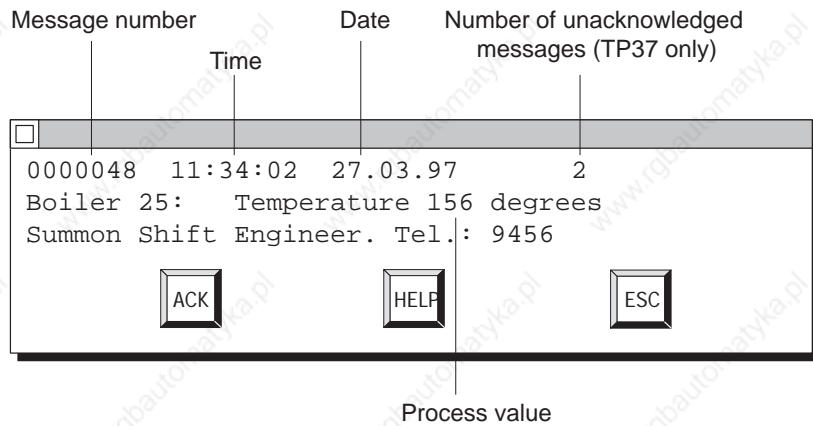

Figure 6-1 Alarm message window (example)

The buttons in the alarm message window have the following significance:

Button	Function	Purpose
	<b>Acknowledge alarm message</b>	When an alarm message is acknowledged, the alarm message window disappears if no other alarm messages are waiting.
	<b>Display help text</b>	Call help text concerning the alarm message, if configured.
	<b>Cancel</b>	Set the alarm message window to the background

**Event message window:**

The event message window must be selected by the operator or the PLC and can also be deselected. If a current event message is not waiting, the standby message is displayed.

Activate the event message window by touching the OPEN EVENT MESSAGE WINDOW button on the *Edit Message* standard screen. The button is inactive if the *Line* setting has been configured for event messages.

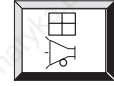

Close the event message window by touching it.

**Message archive**

Alarm and event messages are written in the Touch Panel message archive when they arrive. The message archive is a message buffer, created by the operating system, in which all message events are entered in chronological order. Message events consist of:

- arrival of a message
- acknowledgment of an alarm message
- clearing of a message.

The message archive is a FIFO buffer. When the buffer is full, the oldest messages are deleted.

**Overflow warning**

During configuration, it is possible to define a remainder buffer size for the message archive. As soon as this remaining buffer size is reached, the Touch Panel automatically issues an overflow warning (system message). Messages continue to be entered in the message archive even after the remaining buffer size has been reached.

**Message bit procedure**

If the conditions for issuing a message have been fulfilled in the process currently running, a value has been reached, a bit is set in the data area by the PLC application program for an event or alarm message. The Touch Panel reads the data area after a configured polling time. In this way, a message is detected as having “arrived”. The bit is reset by the PLC when the condition for issuing the message no longer exists. The message is then regarded as having been “cleared”.

## 6.1.2 Alarm Messages

### Acknowledging alarm messages

Alarm messages have to be acknowledged on account of their urgency. This can be done manually or automatically by the PLC.



To acknowledge an alarm message manually, simply touch the ACK button in the alarm message window (figure 6-1 on page 6-4).

If the error messages should be acknowledged by the PLC, continue to read the *Communication User's Manual*.

If several alarm messages are waiting to be displayed, the next alarm message is displayed after one has been acknowledged. Each message must be acknowledged in turn.

### Acknowledgment groups, group acknowledgement

During configuration, several alarm messages can be combined to so called acknowledgment groups. This means that by acknowledging the first alarm message, e.g. the cause of the malfunction, all the remaining alarm messages in the same acknowledgment group are acknowledged simultaneously (consequential malfunctions) without them being issued in succession for acknowledgment on the Touch Panel (group acknowledgement). Up to 16 acknowledgment groups can be configured.

If alarm messages are not assigned to an acknowledgment group, only the message currently displayed is acknowledged when more than one are waiting.

### Message indicator

As soon as an alarm message arrives, an alarm message window is opened and the message indicator shown here appears as a button on the screen.



The message indicator can assume one of two states:

- flashing,  
as soon as at least one unacknowledged alarm message is waiting.
- not flashing,  
when all waiting alarm messages have been acknowledged, but at least one has not yet been cleared.

After touching the message indicator, the alarm message page appears.

The message indicator does not disappear until all acknowledged alarm messages have been cleared. This means that a pending alarm message is not forgotten.

### Setting alarm messages in the background

The alarm message window can be set in the background so that if there are numerous alarm messages pending, it is not necessary to acknowledge them all before rectifying what may be a critical system condition at the machine. Set the window in the background by touching the ESC button in the alarm message window (figure 6-1 on page 6-4). The other touch elements on the screen can then be used.



The alarm messages set in the background are re-displayed

- after touching the message indicator, or
- a new alarm message arrives.



If the alarm message is in the foreground, the alarm message screen can be opened by touching the message indicator. Each subsequent touch opens the alarm message buffer or alarm message screen alternately.

### 6.1.3 System Messages

**Definition**

System messages indicate internal Touch Panel operating statuses. They indicate, for example, maloperations or communication malfunctions. Touch the system message window to close it.

**Structure**

A system message consists of a message number and text, e.g.:

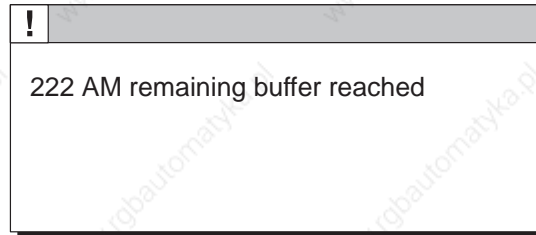

Message text may contain internal system tags for defining the cause of the message more precisely. Some system messages expect an acknowledgement or to make a decision. To determine the further course of events, two buttons are displayed in the system message window; for example

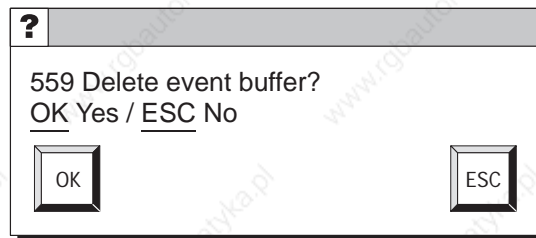

**Serious and non-serious system messages**

System messages are categorized into serious and non-serious messages. A serious system message relates to an error which can be eliminated only by a cold or warm restart of the Touch Panel. All other errors generate non-serious system messages – for example, a configured limit value is not maintained on entry or the current password level is too low for the operator input required. If a non-serious system message is not hidden automatically after a short period of time, hide it by touching the message window. Display can be terminated automatically after a configurable display time expires.

A list of system messages, with explanations, is provided in Appendix C of this manual.

## 6.2 Displaying Messages

### Message archive

All message events are written in the message archive in chronological order. Message events are the arrival, clearing and acknowledgment of a message. A maximum of 512 message events can be stored in the Touch Panel message archive. Every message event is stored with the following information:

- message number
- event identifier  
(A for arrived, D for cleared, K for acknowledged),
- time of the event with date and time of day
- acknowledgment group (alarm messages)
- message text
- values of tags at the time of arrival or clearing.

If a message contains process values, the values stored in the message archive are those which were available when the message event arrived or has been cleared. The *Touch Panel* does not record any current process values for the Acknowledged message status. The value is replaced by ### characters. Figure 6-2 shows the structure of the message archive.

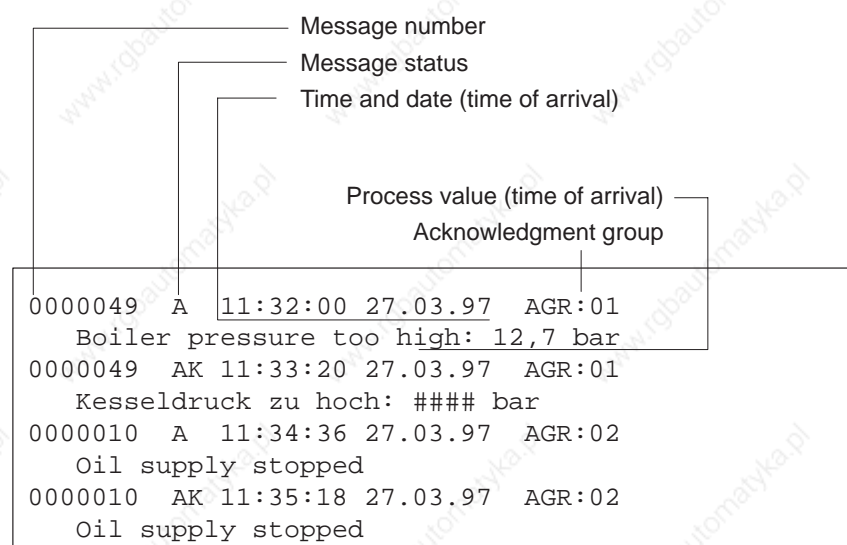

Figure 6-2 Storing message events in the message archive

## Display

The message events in the message archive can be filtered according to various criteria and displayed on the Touch Panel (figure 6-3).

- All waiting event messages are displayed on the event message page.
- All message events for event messages are displayed in the event message buffer. The events related to message events are Arrived and Cleared.
- All waiting alarm messages are displayed on the alarm message screen.
- All message events for alarm messages are displayed in the alarm message buffer. These message events are Arrived, Cleared and Acknowledged.

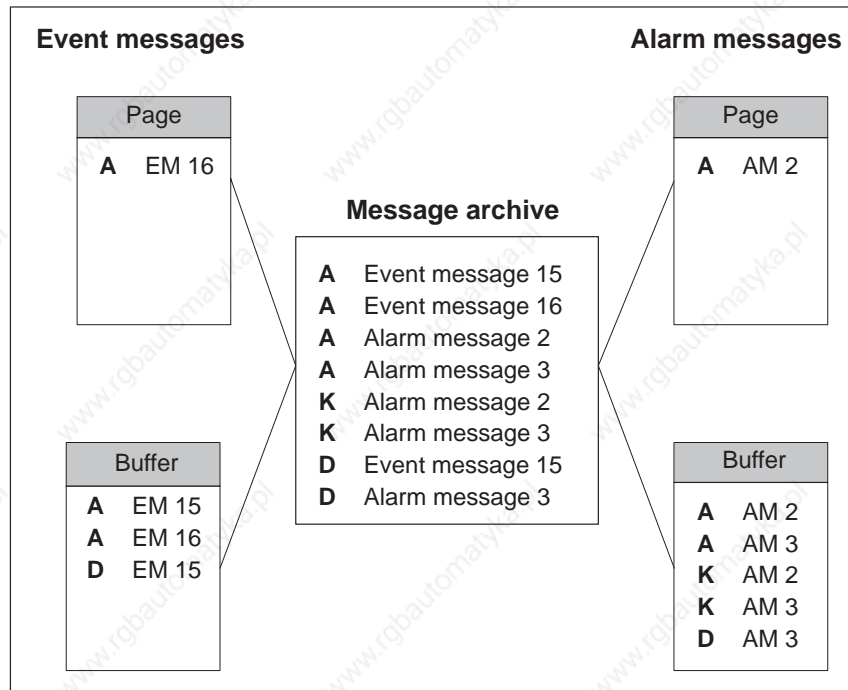

Figure 6-3 Displaying message events on the Touch Panel

## Priority

Within the alarm and event messages, it is possible to configure message priorities according to their importance.

- 1 (low) to
- 16 (high).

If several messages having the same display priority are waiting, they are displayed according to their message priority – the highest first and the lowest last.

## 6.2.1 Opening a Message Page

### Purpose

An overview of the alarm and message events still pending on the Touch Panel is provided from

- the alarm message screen and
- the event message page.

Open message pages are constantly updated.

### Alarm message page

In order to open an alarm message page, touch

- the message indicator
- or
- the OPEN ALARM MESSAGE SCREEN button on the *Edit Message* standard screen

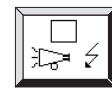

### Event message page

To open the event message page, touch the OPEN EVENT MESSAGE PAGE button on the *Edit Message*

standard screen

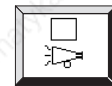

### Structure

The event message screen is sorted chronologically. The sorted order of the alarm message screen also depends on the *First/Last* parameters set on the *System Settings* standard page. Figure 6-4 depicts an example of an alarm message screen.

### Displaying first/last message

Depending on the setting, either the oldest (*first*) or latest (*last*) message is displayed where several messages are pending. This setting can be modified on-line on the *Touch Panel* by means of the *System Settings* standard screen. To do this, touch the MESSAGE DISPLAY field and select either the FIRST or LAST parameter from the selection window.

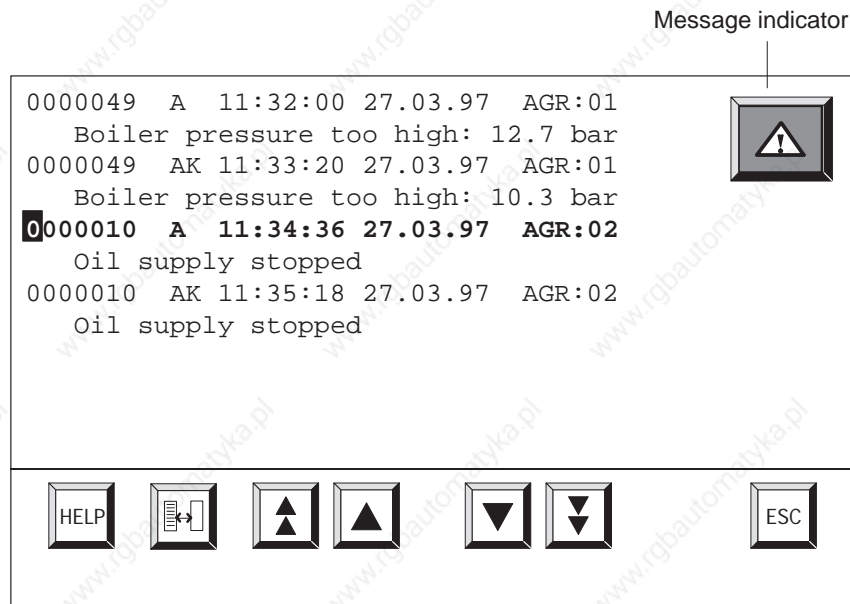

Figure 6-4 Alarm message screen (example TP37 )

**Meanings of buttons**

Button	Function	Purpose
	<b>Scroll</b>	Scroll backwards/forwards one line at a time.
	<b>Jump</b>	Scroll backwards/forwards one screen at a time (TP37 only).
	<b>Display Help text</b>	Call help text for the marked message, if configured.
	<b>Toggle</b>	Toggle back and forth between alarm message screen and alarm message buffer.
	<b>Cancel (Escape)</b>	Close message page.

## 6.2.2 Opening a Message Buffer

### Purpose

An overview of the message events which have arrived on the Touch Panel is provided concerning the

- alarm message buffer
- event message buffer.

Open message buffers are constantly updated.

### Alarm message buffer

In order to open the alarm message buffer, touch

- the message indicator on the alarm message screen
- or
- the OPEN ALARM MESSAGE BUFFER button on the *Edit Message* standard screen

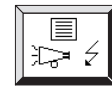

### Event message buffer

To open the event message buffer, touch the OPEN EVENT MESSAGE BUFFER button on the *Edit Message* standard screen



### Structure

The message buffers in the Touch Panel list all the message events which have occurred in chronological order. The basic structure and the significance of the buttons do not differ from those illustrated in the example alarm message screen in figure 6-4.

## 6.3 Deleting Messages

### Purpose

All message events from event and alarm messages are stored automatically in the message archive. The message archive can contain as many as 512 message events. Message events are deleted

- automatically in the case of buffer overflow
- by means of the *Edit Message* standard screen.

### Overflow warning

On reaching the configured remaining buffer size, (default setting 10%), an overflow warning is issued by default. Issue of the the warning can be enabled or disabled via the Touch Panel using the *System Settings* standard screen. To do so, touch the BUFFER OVERFLOW WARNING field and select one of the two parameters, OFF or ON, from the selection window.

### Deleting on buffer overflow

If the message archive is no longer capable of recording more message events, message events are automatically deleted until the capacity configured for the remaining buffer size is reached. Deletion occurs in the following sequence:

- The oldest messages which have already been cleared.  
The message events Arrived and Cleared for an event message which has cleared are deleted. The message events Arrived, Cleared and Acknowledged for an alarm message which has cleared are deleted.
- Messages still waiting.  
If capacity is still not sufficient for new messages, the oldest waiting messages are deleted. This triggers the issue of a system message.

### Automatic printout

In the case of a buffer overflow, a printout of all the alarm and event messages deleted is automatically triggered if

- “Printout on overflow” is configured,
- message logging is deactivated on the Touch Panel, and
- a printer, ready to operate, is connected.

**Deleting via  
standard screen**

The following messages can be deleted from the message archive via standard screen *Edit Message*:

- all (not individual) acknowledged and cleared alarm messages
- all (not individual) arrived and cleared event messages.

Delete alarm messages by pressing the DELETE ALARM MESSAGE BUFFER button.

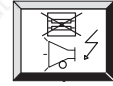

Delete event messages by pressing the DELETE EVENTS BUFFER button.

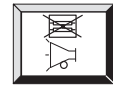

The message events for messages which have not been cleared remain in the message archive.

## 6.4 Printing Messages

### How to print

Alarm and event messages can be printed out

- automatically following buffer overflow (see chapter 6.3),
- automatically as direct message logging,
- manually (see chapter 6.5.2).

Set the printer parameters in the *Printer Settings* standard screen. The standard screen is described in chapter 7.

---

### Note

If a flood of more than 20 messages arrive simultaneously causing the buffer to overflow, it is possible that the messages will not be printed. If this happens “\*\*\*\*\*” appears in the printout instead of messages.

---

### Direct message logging

Alarm and event messages can be printed out directly on arrival and clearing (alarm messages also on acknowledgement) when this has been defined in the message configuration. System messages are not logged.

### Enabling/Disabling direct message logging

Message logging can be enabled/disabled online via the Touch Panel using the *System Settings* standard screen. To do so, touch the MESSAGE LOGGING field and select either of the parameters OFF or ON from the selection window.

The table shows the relationships between the settings on the Touch Panel and the settings configured in ProTool.

Setting in ProTool	Setting on Touch Panel	
	Message Logging ON	Message Logging OFF
Messages	Messages are logged	Messages are not logged
Overflow	Messages are logged	Buffer overflow is printed
Off	Messages are logged	No effect

---

### Note

If Asian character sets are used for messages, the messages are printed in graphics mode.

---

**Manual printout of buffer content**

The buffer contents can be printed out in the following ways:

- The *Edit Message* standard screen (see chapter 6.6.1) has buttons to print out alarm and event messages.
- The *Output Messages* standard screen (see chapter 6.6.2) has buttons to print out alarm and event messages. In addition, it is possible to enter filter criteria concerning the messages to be printed.

## 6.5 ALARM\_S Messages

The STEP 7 option packages S7-PDIAG and S7-GRAPH only issue ALARM\_S messages. For that reason, the message number procedure ALARM\_S must be used for configuring process diagnosis in ProTool as well.

ALARM\_S messages are **not** configured in ProTool but in STEP 7.

### Incorporating ALARM\_S Messages

When configuring messages in STEP 7 the message text and attributes entered are stored in the database shared with ProTool. During the process of compiling the project, ProTool automatically imports the necessary data and subsequently downloads it to the operating unit.

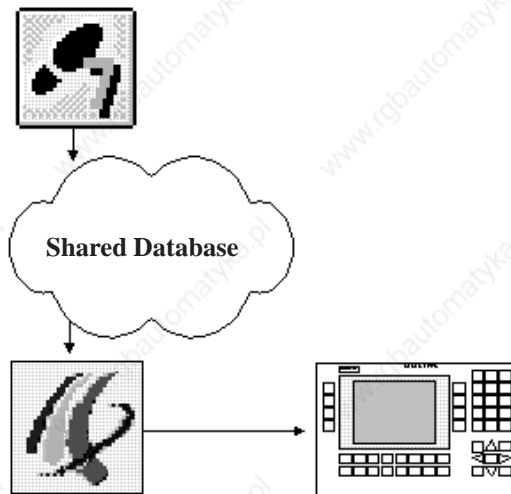

Figure 6-5 Configuring and Downloading ALARM\_S Messages

It is therefore important that the shared database is always up to date during the compilation process and that data synchronization is active.

### Use of Resources

ALARM\_S messages are configured in STEP 7. The data is then stored in a shared database, imported during the process of compiling the ProTool project and finally downloaded to the operating unit.

That means that ALARM\_S messages use up resources on the operating unit. The shorter the messages are, the less storage space they will require.

A maximum of 2000 event messages and 2000 alarm messages can be created. It is of no consequence in this regard which message procedure is used.

### Note

In STEP 7 there are restrictions regarding the number and size of tags that can be used within a message. For more precise details, please consult your STEP 7 documentation.

## 6.5.1 Communication Sequence

### Logging On For ALARM\_S

More than one station (e.g. more than one OP, PU, etc.) on a network can log on for ALARM\_S messages. Each station that wants to display ALARM\_S messages logs on to the CPU for ALARM\_S.

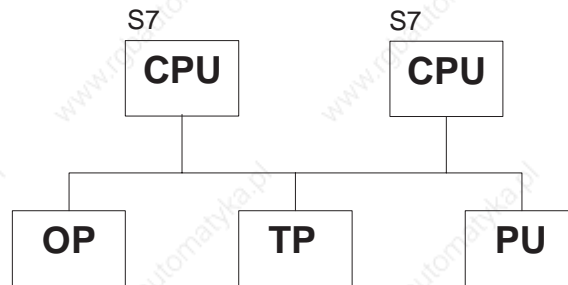

Figure 6-6 MPI Network

### When A Message Event Occurs

When a message-triggering event occurs, the CPU actively sends telegrams to that effect to all stations that have logged on. The message number identifies the corresponding message text that has previously been downloaded to the operating unit.

This means that the CPU does not have to be actively scanned for messages by regular polling as was the case with the message bit procedure. The operating unit, CPU and network are completely relieved of that burden on the system.

### Time Stamp

With the ALARM\_S procedure, the time stamp is not issued by the operating unit but by the CPU. The messages are stored in chronological order on the basis of their time stamp in the message buffer on the operating unit – even if they originate from different CPUs.

### Information Stored

The CPU stores not only the time of the message but also the status (arrived, departed, acknowledged) and any process parameters. That information is retained until a message has been completely processed, i.e. until it has arrived, departed and been acknowledged. On the operating unit, the information in the message buffer is kept even longer.

## 6.5.2 Message Acknowledgement

### **ALARM\_S Messages Requiring Acknowledgement**

When a message is acknowledged by a station on the network, the CPU is immediately notified. The CPU then distributes the acknowledgement to all connected stations. It is only to this message that the operating unit responds, i.e. only at this point does it enter the acknowledgement in the message buffer.

---

#### **Note**

The CPU issues a time stamp for the acknowledgement event but does not store it. It is therefore not possible in the event of a subsequent update to determine whether or when a message has been acknowledged.

---

### **ALARM\_S Messages Not Requiring Acknowledgement**

In the case of those ALARM\_S messages that although they are configured as alarm messages do not require explicit acknowledgement by the user, the CPU acknowledges the message automatically when it arrives. The acknowledged event is then immediately entered in the message buffer along with the arrived event.

## 6.5.3 Printing Messages

You specify which messages are to be printed in the usual way in ProTool by choosing the menu option *System* → *Messages* → *Settings*.

### **Message Logging**

If you do not specify any device-specific message settings in STEP 7, all message events are automatically logged directly to the connected printer.

If you configure device-specific messages, you can specify separately for each message whether it is to be logged or not.

If there are several CPUs in a network, this means that messages may not always be received in chronological order by the operating unit. Messages are always printed in the order in which they are sent by the CPUs. This is also the case with every synchronisation.

### **Printing Messages In the Event of a Buffer Overflow**

Printing of the message buffer contents in the event of a buffer overflow is carried out in the same way as with the familiar message bit procedure. All messages are printed before being deleted.

## 6.5.4 Message Overload

It can happen that a large number of ALARM\_S messages are issued within a short space of time. This can result in the build-up of processing backlogs.

### Communication Overload

If the time gap between the first occurrence of a message and a subsequent occurrence is very short, it may be that the first message has not yet even been sent. In that case, the CPU reports the current status, i.e. the most recent occurrence of the message. Every station, i.e. including the operating unit, is informed at the same time, however, that at least one signal change that could not be sent has occurred.

The message number appears on the operating unit in inverted type (light letters on dark background) if multiple arrivals and departures of the message have not been able to be recorded.

```
*1234567 A KGQ HH:MM:SS DD.MM.YYYY GRU00
Boiler 13: temperature 190 degrees
Inform shift supervisor Tel. 007
```

Figure 6-7 Multiple Arrivals and Departures Could Not Be Recorded

### CPU Memory Overload

If there are more messages pending than the CPU can process, any new messages are discarded. Only when a message has been fully processed can a new message be processed.

The date and time of a message appear on the operating unit in inverted type (light letters on dark background) if it is the last message that could be accepted by the CPU message buffer.

```
*1234567 A KGQ HH:MM:SS DD.MM.YYYY GRU00
Boiler 13: temperature 190 degrees
Inform shift supervisor Tel. 007
```

Figure 6-8 Last Message Accepted by the CPU

### Operating Unit Overload

An operating unit can process a maximum of approx. 200 simultaneously pending messages (total number of event and alarm messages). If the operating unit then receives more messages from the CPUs on the network, they can no longer be displayed. A system message to that effect is then displayed on the operating unit.

The maximum number of messages that could theoretically be simultaneously pending on an operating unit is calculated from the sum of the maximum numbers possible on the connected CPUs.

**Example:**

A CPU 315 can process a maximum of 50 simultaneously pending messages. Accordingly, an operating unit can handle a maximum of four CPU 315s sending ALARM\_S messages without overflow problems occurring.

### 6.5.5 Updating

Since the CPU stores the message information when a fault occurs, individual network stations (e.g. an OP) can log on at a later date and obtain an update.

However, the CPU only stores information about pending messages. Once all events (arrival, departure, acknowledgement) have occurred, the message is deleted from the CPU.

When obtaining an update, therefore, the operating unit processes any missing events automatically if a message is not known to the PLC but the arrival and acknowledgement events are not entered on the operating unit.

The events are not entered in the message buffer in that case, however.

Events processed in this way are identified on the operating unit by displaying the message status symbols in inverse type thus:

```
*1234567 A KQ HH:MM:SS DD.MM.YYYYGRU00
Boiler 13: temperature 190 degrees
Inform shift supervisor Tel. 007
```

Figure 6-9 Automatically Processed Events

## 6.5.6 Buffer Overflow

**Message Archive** All message events for event and alarm messages are automatically stored in a message archive. The message archive can hold up to 512 message events.

**Overflow Warning** When the remaining buffer capacity specified in ProTool (default setting 10%) is reached, an overflow warning is automatically issued.

**Deleting Message Events In the Event of a Buffer Overflow** If the message archive has insufficient space to accept any more message events, message events are automatically deleted until the specified remaining buffer capacity is reached.

Deletion is carried out in the following order:

1. The oldest departed messages.

For departed event messages, the message events *arrival* and *departure* are deleted. For departed alarm messages, the message events *arrival*, *departure* and *acknowledged* are deleted.

2. Pending messages.

The oldest pending messages are deleted to make space for the newly received events.

**Printout** If *Buffer Overflow Message Logging* has been specified and a printer is connected and switched on, all deleted alarm and event messages are printed out in the event of a buffer overflow.

## 6.6 Standard Screens for Messages

### Overview

The two standard screens below are significant for messages:

- *Edit Message*
- *Output messages*
- *System Settings*

### 6.6.1 “Edit Message” Standard Screen

#### Purpose

Functions are configured in the *Edit Message* standard screen which are necessary to view, delete and print messages (figure 6-10).

Open the *Edit Message* standard screen from the main screen by pressing the button

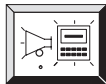

#### Structure

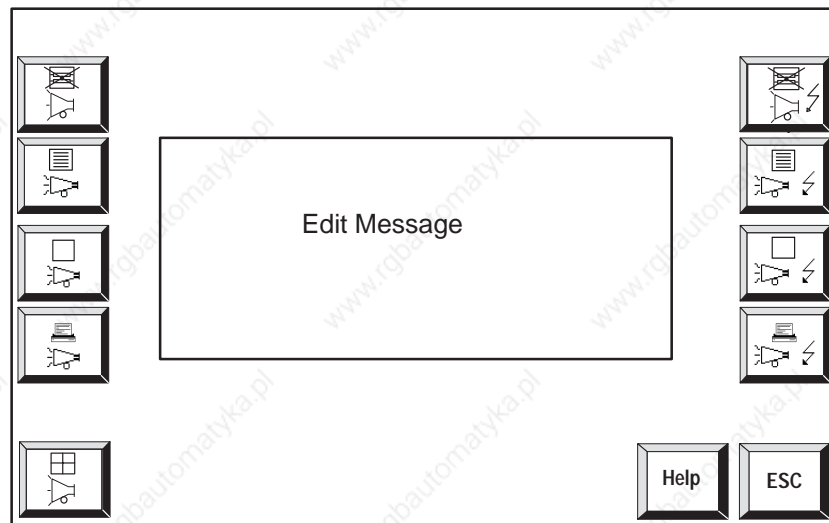

Figure 6-10 Standard screen *Edit Message*

**Meanings of buttons**



Open event message window



Open event message page



Open event message buffer



Delete event message buffer



Print event message buffer



Open alarm message screen



Open alarm message buffer



Delete alarm message buffer



Print alarm message buffer



Call Help text on standard screen



Exit from standard screen

## 6.6.2 “Output Messages” Standard Screen

### Condition

In order to select and print messages via the Touch Panel according to filter criteria, the *Output Messages* standard screen must be integrated in the configuration.

### Purpose

The *Output Messages* standard screen enables the selection and printing of messages according to various, user-defined filter criteria (figure 6-11).

### Structure

Output Messages

Output medium: [input field]

Message event: [input field]

Priority: [input field]

Date: [input field]

Text: [input field]

Acknowledgment group: [input field]

[Printer icon] [Printer icon with lightning bolt and ESC]

Figure 6-11 Standard screen *Output Messages*

Meaning of operating elements	Output medium	PRINTER The factory setting for output from units TP27 and TP37, is to a printer.
	Message event	<p><b>ALL</b> All the alarm messages or event message buffer contents are printed out. This includes all message events which have Arrived, Cleared or been Acknowledged.</p> <p><b>ARRIVED ONLY</b> Only the Arrived message events stored in the buffer are printed.</p> <p><b>CLEARED ONLY</b> Only the Cleared message events stored in the buffer are printed.</p> <p><b>ACKNOWLEDGED ONLY</b> Only the Acknowledged message events stored in the buffer are printed.</p> <p><b>ARRIVED AND CLEARED</b> Only the Arrived and Cleared message events stored in the buffer are printed.</p> <p><b>ARRIVED AND ACKNOWLEDGED</b> Only the Arrived and Acknowledged message events stored in the buffer are printed.</p> <p><b>CLEARED AND ACKNOWLEDGED</b> Only the Cleared and Acknowledged message events stored in the buffer are printed.</p>
	Priority	<p>0 to 16 Only those message events are printed which have at least the specified priority.</p>
	Date	<p>Only those message events with the specified date are printed.</p>
	Text	<p>Only those message events are printed which contain the specified character string. Upper/lower case is not considered.</p>
	Acknowledgment group	<p>0 to 16 Only those message events are printed which belong to the specified acknowledgement group.</p>

### 6.6.3 “System Settings” Standard Screen

**Purpose**

Different settings can be defined for messages using the symbolic input fields in the *System Settings* standard screen. Open the *System Settings* standard screen from the main screen by pressing the adjacent button

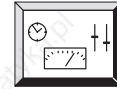

**Structure**

TP27 and TP37 have different *System Settings* standard screens. Figure 6-12 illustrates an example of the *System Settings* standard screen for the TP27-10. Fields relevant for messages are shown grey.

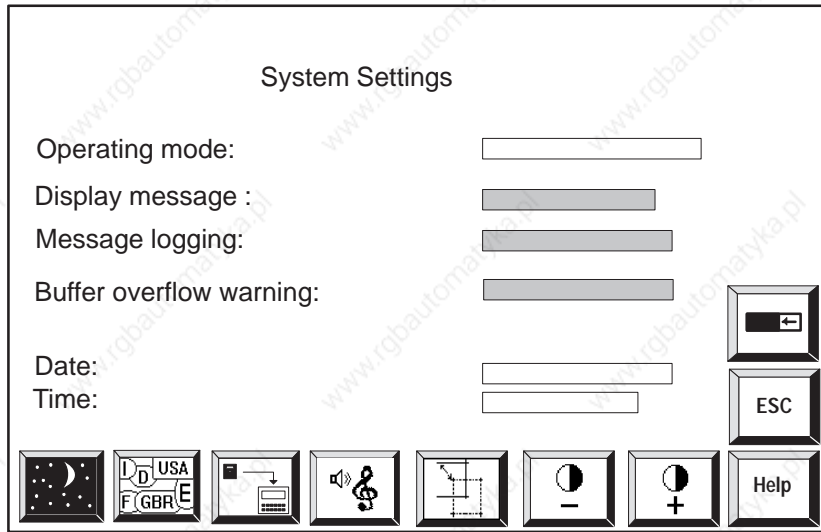

Figure 6-12 *System Settings* standard screen for TP27-10

**Meaning of operating elements**

Only the operating elements of interest as regards messages are listed below. See chapter 11 for a description of the other fields and buttons.

**Message display**

FIRST

The oldest alarm message is displayed first.

LAST

The most recent alarm message is displayed first.

**Message logging**

ON

Alarm messages and event messages are printed in addition to being displayed.

OFF

Alarm messages and event messages are printed only on buffer overflow.

**Overflow warning**

ON

A system message is issued when the remaining buffer size is reached.

OFF

No message is issued when the remaining buffer size is reached.

Call Help text on standard screen



Exit from standard screen





## Printing

### Connecting a printer

A monochrome printer or color printer can be connected to the Touch Panels. Configuration of the connection is described in section 12.2.4. Descriptions of the interfaces is provided in Appendix B.

### Print functions

The following print functions are provided on the Touch Panel:

- **Print Messages** (see section 6.4).  
All the message events which occur (Arrived, Departed, Acknowledged) are printed on the printer. Screen prints and screens can be printed during message logging.
- **Print Buffer**  
The entire event message or alarm message buffer contents are printed on the printer. Filter criteria can be defined for the printout (see Chapter 6.5.2).

- **Print Screen**  
If you wish to use this function on the Touch Panel, you have to assign the PRINT SCREEN function to a button when configuring. Touching the button prints the displayed screen. Windows currently shown on the screen – for example, the message window – are not printed together with the screen. You can abort the Print Screen function by touching the button again. A system message indicates that the Print Screen function has been aborted.

- **Print Screen List**  
To use this function on the touch screen, the PRINT SCREEN LIST function must be assigned to a button during configuration. This function can be used to print up to twenty screens in succession at one page per screen. If there are output fields on a screen for process values, the values current at the time of printing are read out from the PLC.

ASCII is the default printing mode; in other words, graphic elements such as graphics, trends and bar graphs are not printed. Print Screen is not possible while printing is in progress. If the *Graphics mode for screen list printing* is configured for individual screens, these screen lists are printed complete with all elements, i.e. including graphics, trends, bar graphics, etc.

In order to print all the screens selected using the *Print screen list* function in Graphics mode, it must be defined in the configuration using the global function *Automatic graphics printing*.

**Standard screen**

The settings configured for printer type and printer parameters can be modified online via the symbolic input fields

- with the TP27-6 in standard screens *Printer Settings General*, *Print Screen* and *Assign Color* (figure 7-1),
- with the TP37 and TP27-10 in standard screen *Printer Settings* (figure 7-2).

Make sure that the parameters on the Touch Panel match those on the printer.

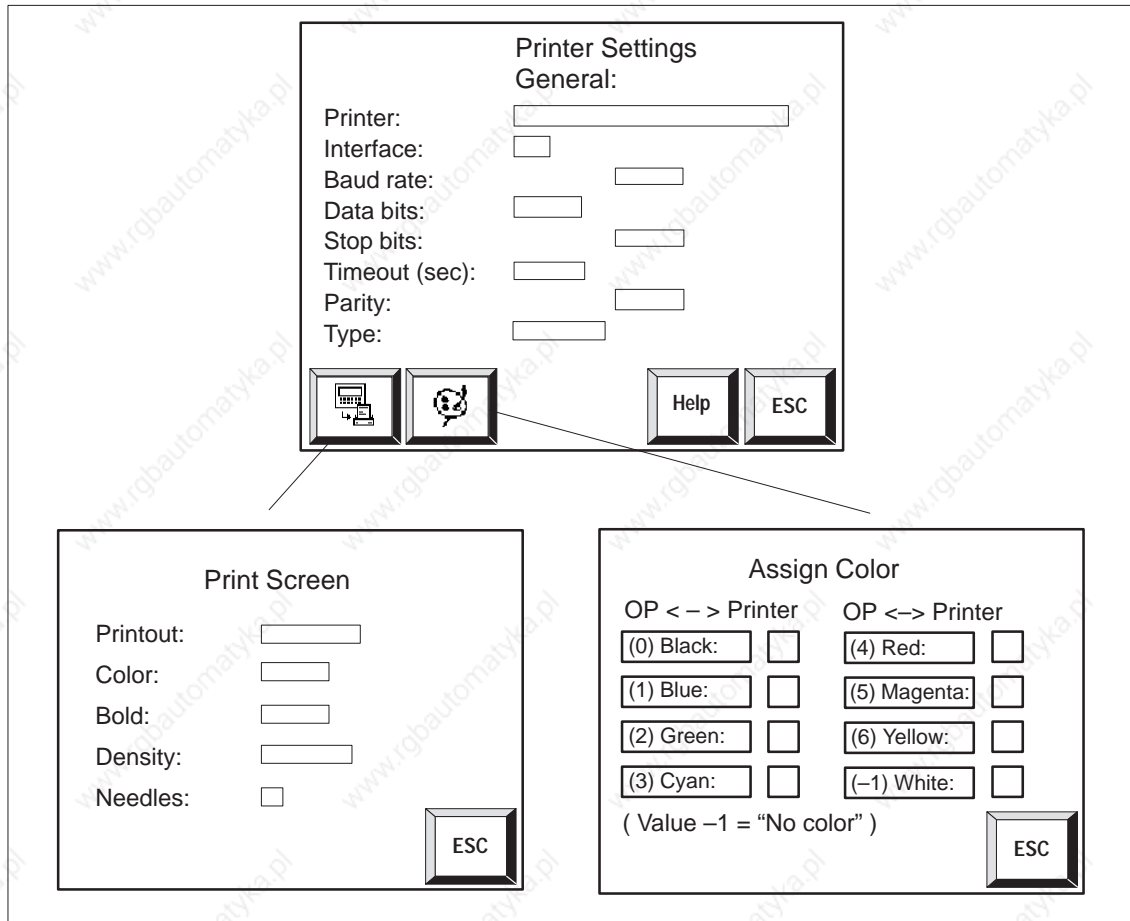

Figure 7-1 Standard screens for printer settings (example TP27-6)

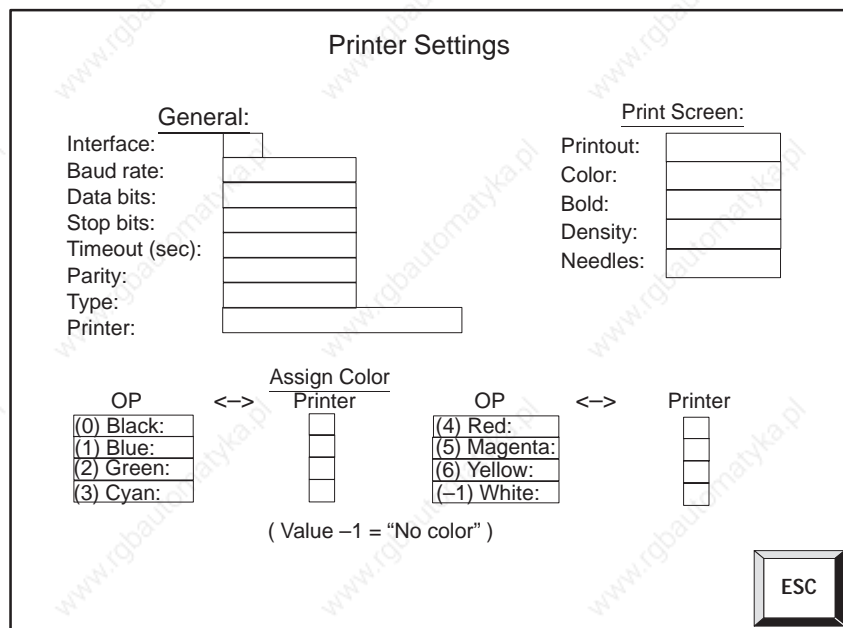

Figure 7-2 Standard screen *Printer Settings* (example TP37 and TP27-10)

**Meaning of operating elements**

**Interface**

Set printer interface:

- IF2 (serial)
- LPT (parallel, TP37 only)

**Transfer Parameters**

Standard setting (serial):

- BAUD RATE: 9600
- DATA BITS: 8
- STOP BITS: 1
- PARITY: None
- TIMEOUT (S): 60

Do not change the parameters unless they do not match the transfer parameters of your printer.

**Printer**

Select a printer from the list of configured printers.

### Print Screen

ASCII (default setting):

Only ASCII characters are printed in a screen printout (no graphics or character graphics). An ASCII screen print is appreciably quicker than a graphic screen print.

A screen which contains text characters belonging to an Asiatic character set is always printed in graphics mode, irrespective of the ASCII default setting.

GRAPHIC:

All elements on the screen are printed in a screen print, including graphics, trends and bar graphs.

### Assign Color

Disable individual colors (-1) or modify color assignment.

Example:

You wish to use black (0) as the color instead of blue (1).



Switch to the *Hardcopy* standard screen (TP27-6 only).



Switch to the *Assign Color* standard screen (TP27-6 only).



Call Help text



Exit from standard screen

## Recipes

### Purpose

Recipes consist of combinations of tags for a specific application. The purpose of recipes is to transfer several items of data collectively to the PLC. This transfer requires synchronization between the touch screen and the PLC.

### Data records

The data structure is defined with the data record in the configuration. Data is assigned to the structure on the Touch Panel. This data structure (recipe) can be used more than once and different data can be assigned to it. We refer to data records to which data has been assigned as “data records”. Data records are stored on the Touch Panel. This saves memory space on the PLC.

### Example of a recipe

The same bottling machine of a fruit juice filling system is to be used to produce orange nectar, an orange drink and orange juice. The mixing ratios are different for each drink, though the ingredients are always the same. The production details are configured in this example as the “Mixture” recipe.

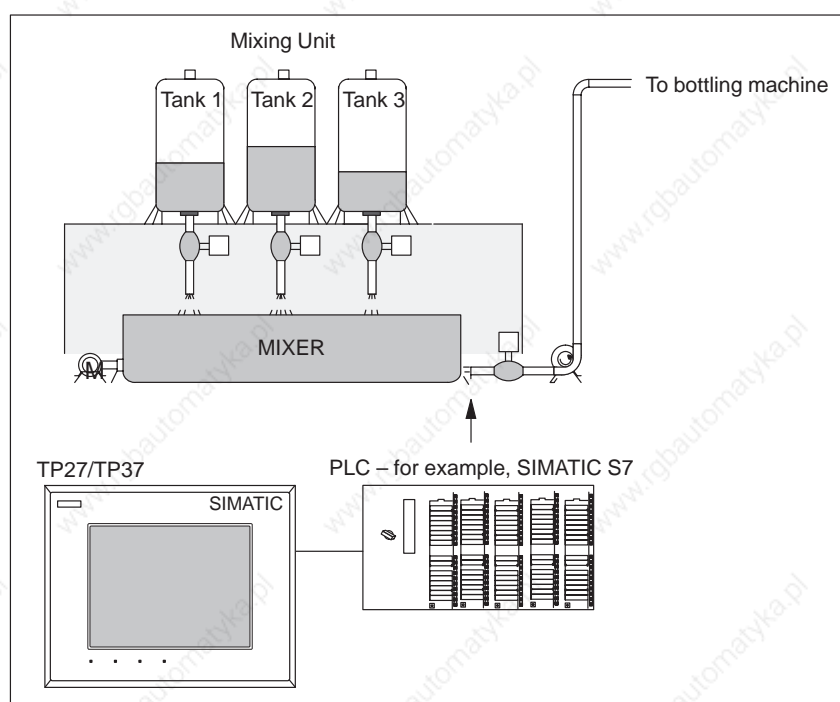

Figure 8-1 Example: Fruit juice system

**Ingredients of a recipe**

A recipe consists of a series of recipe entries. Each entry contains no more than one input field (tag).

The *Mixture* recipe might contain the following entries:

Name:	<input type="text"/>	
Orange:	<input type="text"/>	l
Water:	<input type="text"/>	l
Sugar:	<input type="text"/>	kg
Flavor:	<input type="text"/>	g

|  
Input fields (variables)

**Data records on the Touch Panel**

Values are assigned to the input field variables on the Touch Panel and stored. Together, these values form one data record of the recipe.

Several data records can be created for one recipe. This enables the fruit juice system, for example, to produce drinks of different kinds. It uses a different data record for each drink:

Name:	Beverage	Nectar	Juice
Orange:	90 l	70 l	95 l
Water:	10 l	30 l	5 l
Sugar:	1.5 kg	1.5 kg	0.5 kg
Flavor:	200 g	400 g	100 g
"Mixture" recipe entries	Data record 1	Data record 2	Data record 3

All data records are stored in the Touch Panel. Only the currently active data record is stored on the PLC. This saves memory space on the PLC.

**Identifying recipes**

A recipe is created under a symbolic name in the configuration. The recipe is then selected using this symbolic name on the Touch Panel.

## 8.1 Standard Screens for Recipes

### Condition

In order to create, save and download data records using the Touch Panel, the standard screen *Data Record Processing and Transmission* must be integrated in the configuration. The *Selective Data Record Transmission* standard screen need only be integrated in the configuration when current data has to be exchanged between the Touch Panel and PLC.

### Purpose

Data records are created, modified and deleted using the standard screen *Data Record Processing and Transmission*. It is also possible to use the standard screen to transfer data records from data media (flash or memory card) to the PLC or vice versa. The standard screen *Selective Data Record Transmission* is only required when data records need to be transferred between specific Touch Panels, data media or PLCs. A detailed description of handling standard screens is provided in Section 8.1.1.

### Standard screen Edit Data Records

Use the standard screen *Data Record Processing and Transmission* (figure 8-2) to

- create and edit data records on the Touch Panel and save these records on a data medium,
- transfer the records from data media to the main memory of the Touch Panel and from there to the PLC,

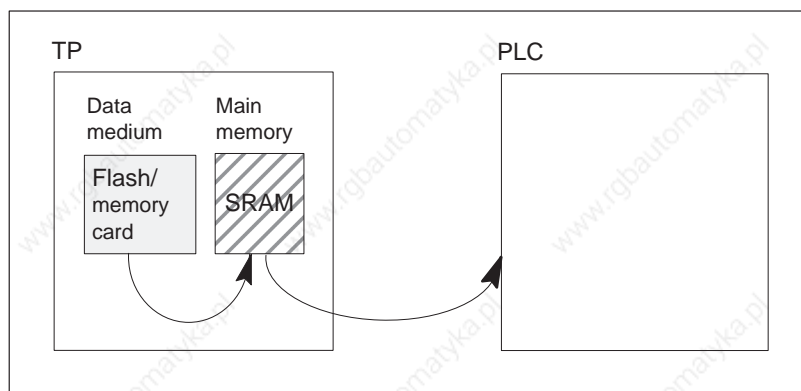

- delete data records on the data medium
- edit data records on the Touch Panel.

The structure of a recipe cannot be modified on the Touch Panel.

**Data Record Processing and Transmission**





Recipe:

Data record name:

Comment:

Sort order:

Data medium:

Help

ESC

Figure 8-2 Input fields and buttons in standard screen *Data Record Processing and Transmission* (example TP37)

**Meaning of operating elements**



Copy current values from the PLC to the main memory of the Touch Panel and save them as a data record on the data medium *flash* or *module* (memory card).



Load selected data records from data medium to the main memory of the Touch Panel and transfer from there to the PLC.



Delete selected data record on the data medium.



Create and modify selected data record on the data medium.



Select data record from recipe data.



Call Help text on standard screen.



Exit from standard screen

<b>Recipe</b>	Select a recipe from the list of configured recipes.
<b>Data record name</b>	Enter the name of the new data record or the data record to be edited.
<b>Comment</b>	Enter a comment in respect of the data record to be edited. The comment entered is only accepted when the data record is stored on the data medium. It is not accepted if the data record is saved a second time. In this case, the comment must be entered in the Edit window (refer to figure 8-4 on Page 8-10).
<b>Sort order</b>	Define the sort criteria for the list of data records. Select from the following sort criteria: <ul style="list-style-type: none"> <li>• unsorted,</li> <li>• alphabetic,</li> <li>• alphabetic reversed,</li> <li>• chronological,</li> <li>• chronological reversed.</li> </ul>
<b>Data medium</b>	Select one of the data media <i>flash</i> or <i>module</i> (memory card) here.  Format the data medium using the <i>Format</i> list box.

**Standard screen  
Transfer Data  
Record**

Current values can be downloaded from the Touch Panel to the PLC and vice versa, without having to store them on a data medium. This makes the startup phase of a process easier, for example. Similarly, transfer between the Touch Panel and data medium is also possible.

Using the standard screen *Selective Data Record Transmission* (figure 8-3) it is possible to

- transfer the current values from the PLC to the main memory of the Touch Panel,
- transfer the current values from the main memory of the Touch Panel to the PLC,
- load data records from data medium into the main memory of the Touch Panel,
- transfer data records from the main memory of the Touch Panel to data medium.

**Selective Data Record Transmission**





Recipe:

Data record name:

Comment:

Sort order:

Data medium:

Help

ESC

Figure 8-3 Input fields and buttons in standard screen *Selective Data Record Transmission* (example TP37)

**Meaning of operating elements**



Transfer current values from the PLC to the main memory of the Touch Panel (update values in the Touch Panel)



Transfer the current values from the main memory of the Touch Panel to the PLC.



Transfer data record from the data medium to the main memory of the Touch Panel.



Transfer data record from the main memory of the Touch Panel to the data medium.



Select data record.



Call Help text on standard screen.



Exit from standard screen

<b>Recipe</b>	Select a recipe from the list of configured recipes.
<b>Data record name</b>	Enter the name of the data record you wish to transfer.
<b>Comment</b>	Enter a comment in respect of the data record to be edited.
<b>Sort order</b>	Define the sort criteria for the data records to be transferred. Select from the following sort criteria: <ul style="list-style-type: none"> <li>• unsorted,</li> <li>• alphabetic,</li> <li>• alphabetic reversed,</li> <li>• chronological,</li> <li>• chronological reversed.</li> </ul>
<b>Data medium</b>	Select one of the data media <i>flash</i> or <i>module</i> (memory card) here.

## 8.1.1 Creating, Editing and Saving Data Records

### In this section

The data structure is defined with the recipe during configuration. Initially, there are no data records. They are created, edited and stored on data media directly on the Touch Panel using the standard screen *Data Record Processing and Transmission*.



How to operate the standard screen *Data Record Processing and Transmission* is the subject of this section.

### Formatting data media

Before a data record can be stored, the data medium must be formatted. To do this, use the formatting function in the input field beneath the data medium selection.

#### Note





Any data records on the data medium are deleted by the formatting operation. Formatting of a data medium cannot be undone.

Step	Action
1	Touch the <i>Format</i> field of standard screen <i>Data Record Processing and Transmission</i> .
2	Select the formatting function from the selection window by touching 
3	Confirm the prompts in the following two system message windows by touching  or cancel the action by touching 

**Creating a new data record**

Step	Action
1	Touch the <i>Recipe</i> field of the standard screen <i>Data Record Processing and Transmission</i> . Select the recipe for the new data record in the selection window.
2	Touch the <i>Data Medium</i> field. Select from the selection window the data medium on which you want to save the new data record.
3	Touch the <i>Data Record Name</i> field. Enter the name of a data record, which does not yet exist, in the input window . To save the data record on a disk, the name may only consist of alpha characters and digits from the normal level of the alphanumeric keyboard. The length is limited to 11 characters.
4	Edit the data record and then download it to the data medium.

**Editing a data record**

Step	Action
1	Touch the <i>Recipe</i> field in the standard screen <i>Data Record Processing and Transmission</i> . Select the recipe for the data record to be edited from the selection window.
2	Touch the <i>Data Medium</i> field. Select the data medium from the selection window on which the edited data record should be saved .
3	Select the name of the data record which you which to edit. There are two ways of doing this: <ul style="list-style-type: none"> <li>• Touch the button  and select the data record from the selection window or</li> <li>• Touch the <i>Data Record Name</i> field and enter the name of the data record in the input window.</li> </ul>
4	Touch the button 
5	Edit the data record in the edit window (figure 8-4).
6	Confirm the change by touching  or discard the change by touching 

**Edit window**

The entries of the selected data record are listed in the Edit window (figure 8-4). Each line contains the configured name on the left and the editable value of the entry on the right.

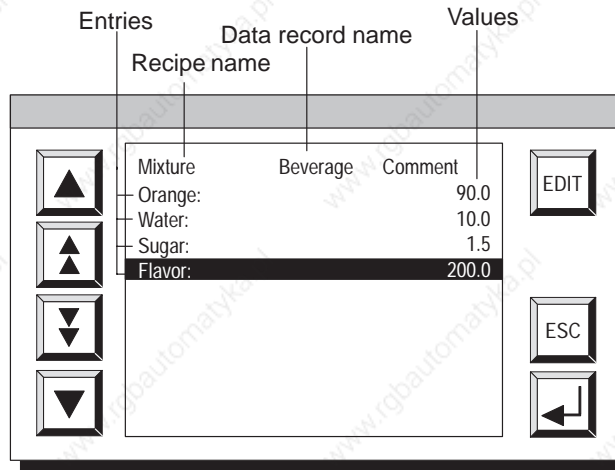











Figure 8-4 Edit window for data records

**Meanings of buttons**

Button	Function	Purpose
 	<b>Scroll (cursor)</b>	Scroll up and down one line at a time through the list of entries.
 	<b>Jump</b>	Browse forwards and backwards in the entry list screen by screen.
	<b>Edit</b>	Edit selected entry.
	<b>Cancel (Escape)</b>	Discard input and close window.
	<b>Enter</b>	Confirm input and close window.

### Saving data records

Current values can be copied from the PLC to the Touch Panel main memory and saved on a data medium. The time at which the data record was saved is also stored.

Step	Action
1	Touch the <i>Recipe</i> field in standard screen <i>Data Record Processing and Transmission</i> . Select the recipe for the data record to be saved from the selection window.
2	Touch the <i>Data Medium</i> field. Select the data medium on which the data record is to be saved from the selection window .
3	Select the name of the data record to be saved (see <i>Editing a data record</i> , Step 3, Page 8-9).
4	Touch the button  If a data record with this name does not exist, it is created. If a data record with this name already exists, the system asked whether the existing data record should be overwritten.
5	Confirm by touching  or cancel the action by touching 
6	Repeat steps 1 to 5 for each data record to be saved on the data medium.

### Loadig data records



Proceed as follows to load data records from data media in the main memory of the Touch Panel and download them to the PLC:

Step	Action
1	Touch the <i>Recipe</i> field in standard screen <i>Data Record Processing and Transmission</i> . Select a recipe for the data record to be loaded from the selection window.
2	Select the name of the data record to be loaded (see <i>Editing a data record</i> , Step 3, Page 8-9).
3	Touch the <i>Data Medium</i> field. Select the data medium from which the data record is to be loaded from the selection window .
4	Touch the button 

**Deleting data records**

The following section describes the sequence for deleting individual data records fro the selected data medium. If all the data records on the data medium are to be deleted, it is more practical to use the Format function (see Page 8-8).

If the data record to be deleted from the data medium is active on the PLC, it remains active on the PLC even after it has been deleted.

Step	Action
1	Touch the <i>Recipe</i> field in standard screen <i>Data Record Processing and Transmission</i> . Select the recipe for the data record to be delete from the selection window.
2	Touch the <i>Data Medium</i> field. Select the data medium containing the data record to be deleted from the selection window .
3	Select the name of the data record to be deleted (see <i>Editing a data record</i> , Step 3, Page 8-9).
4	Touch the button 
5	Confirm the prompt which follows by touching  or cancel the action by touching 

## 8.1.2 Transferring Data Records

### In this section

The following section describes how to operate the *Selective Data Record Transmission* standard screen. This standard screen contains special functions configured for transferring data records between the Touch Panel and PLC and between Touch Panels and data medium. As opposed to transfer using standard screen *Data Record Processing and Transmission*, intermediate steps are provided here for the transfer process. This means that it is possible to load a data record from the PLC in the main memory of the Touch Panel, edit the data record and then transfer the record back to the PLC with modified values.

### PLC → Touch Panel

Proceed as follows to update the values in the data record in the Touch Panel main memory with values from the PLC:

Step	Action
1	Touch the <i>Recipe</i> field in the standard screen <i>Selective Data Record Transmission</i> . Select the recipe for the data record you wish to update from the selection window.
2	Touch the button 

### Touch Panel → PLC

Proceed as follows to transfer the current values in the main memory of the Touch Panel to the PLC:

Step	Action
1	Touch the <i>Recipe</i> field in standard screen <i>Selective Data Record Transmission</i> . Select a recipe for the data record to be transferred from the selection window.
2	Touch the button 

**Data medium →  
Touch Panel**

Proceed as follows to load a data record from a data medium in the Touch Panel main memory:

Step	Action
1	Touch the <i>Recipe</i> field in standard screen <i>Selective Data Record Transmission</i> . Select a recipe for the data record to be loaded from the selection window.
2	Touch the <i>Data Medium</i> field. Select the data medium from which to load the data record from the selection window .
3	Select the name of the data record to be loaded into the main memory of the Touch Panel (see <i>Editing a data record</i> , Step 3, Page 8-9).
4	Touch the button 

**Touch Panel →  
Data Medium**

Proceed as follows to save a data record in the main memory of the Touch Panel on a data medium:

Step	Action
1	Touch the <i>Recipe</i> field in standard screen <i>Selective Data Record Transmission</i> . Select the recipe for the data record to be saved from the selection window.
2	Touch the <i>Data Medium</i> field. Select the data medium on which the data record is to be saved from the selection window.
3	Select the name of the data record to be save (see <i>Editing a data record</i> , Step 3, Page 8-9).
4	Touch the button 

## 8.2 Record Sets

### Definition

A record set combines one data record from several different recipes under a common name.

In its data records, a record set contains all the values required to set up a machine or system. This means, for example, that the basic settings for machines which operate simultaneously can be loaded to produce different products.

### Example

In order to simplify the general overview, the ORANGE fruit juice system used in this chapter is extended by the production lines GRAPEFRUIT and LEMON. To do this, the recipes GRAPEFRUIT and LEMON are set up. Each of these recipes has a data record called "Drink". These three data records form the record set called "Drink".

The data record "Drink" for all three recipes can be downloaded simultaneously to the PLC in a single transfer action, thus starting production of the "Drink".

### Editing

A record set is edited in the *Data Record Processing and Transmission* standard screen the same as a data record.

The editing options are:

- Select
- Save (Create)
- Load
- Delete

### Selecting

Select the recipe name *RecordSet* from the selection window. If "Record set" has been chosen as the recipe, all the data records of all recipes are displayed following selection of the data record. Record sets (data records which are present in several recipes) are identified by \* in front of their name.

## Save (Create)

A Record Set can be created in standard screen *Data Record Processing and Transmission* in two different ways, i.e. saved on a data medium:

### 1. Save a data record for each recipe

Step	Action
1	Select <i>RecordSet</i> as the recipe.
2	Define the data record name and the data medium.
3	Save the record set as with a data record. A data record is created for each recipe.
4	Delete any data records not required.

### 2. Save a data record individually for selected recipes

Step	Action
1	Select the recipe name, e.g. <i>ORANGE</i> .
2	Define the data record name (e.g. <i>Drink</i> ) and data medium. Each data record name must be created with the same name (= <i>Drink</i> ).
3	Edit the data record and save it.
4	Repeat steps 1 and 3 for each data record.

## Load

During the loading procedure all the data records with the selected name located on the data medium are loaded on the Touch Panel and transferred on to the PLC. The sequence of steps corresponds to the procedure described on Page 8-11 under *Loading data records*.

### Note

- It may take a relatively long time to upload a record set from the data medium to the PLC, depending on the size of the recipes. A record set should, therefore, only contain essential recipes.
- During the following downloading procedure, **all** current values of **all** recipe tags are transferred, and not just the data records with the same name:
  - PLC → TP
  - PLC → × Data medium
  - TP → × PLC

**Delete**

- **Complete record set:**  
The sequence of steps corresponds to the procedure described on Page 8-12 under *Deleting data records*.
- **Partial record set:**  
Delete the data records with the corresponding name individually from the selected data records. The sequence of steps corresponds to the procedure described on Page 8-12 under *Deleting data records*.

**Modify**

Record sets cannot be modified. Only the individual data records in the record set can be modified. The sequence of steps corresponds to the procedure described on page 8-9 under *Editing data records*.



## Storing and Loading Data

### In this chapter

This chapter explains

- how to transfer data to different data media,
- which settings have to be performed,
- what must be taken into consideration.

### Purpose

Depending on the type and quantity, data is loaded onto data media to

- back up data,
- restore data,
- load or store recipe data records,
- load data from the configuration computer to a different Touch Panel,
- download Touch Panel firmware.

## 9.1 Data Types, Data Media and Storage Principle

### Data types

Data is divided into the following categories:

- configuration data
- firmware data and
- recipe data.

### Data media

Touch Panels are equipped with the data media *internal flash* and *memory card*.

### Internal flash memory

The internal flash memory is a standard storage medium in the Touch Panel. The storage capacity is 1 Mbyte in the TP27–6 and 2 Mbytes in the TP27–10 and TP37. All data types can be stored in the flash memory. Memory allocation depends on the size of the configuration, the firmware and the data area configured for data records.

### Memory card

The memory card is an external memory medium, comparable to a disk. Compared to the internal flash memory, the memory card features the following advantages:

- The memory card is a portable storage medium. This means that, for example, recipe data can be transported from one TP to another. In this way, changes to configurations or firmware updates can be performed on systems on which no configuration computer is immediately available for transferring such data.
- Configurations can be loaded directly from the memory card because a Touch Panel detects a card when inserted. In this case, the units access the memory card first and then the internal flash memory.
- Its storage capacity of up to 16 MB provides space for large configurations or a large number of recipe data records.



---

### Caution

Memory cards containing stored configurations must be used only in Touch Panels of the same type. If not, you might provoke a system crash.

---

### Storage principle

Data can only be saved in the following combinations for practical purposes:

- firmware, configuration and recipe data records, or
- firmware and configuration.<sup>1)</sup> or
- recipe data.

<sup>1)</sup> This function is not contained on the standard screen and has to be configured.

## 9.2 Delete Storage Medium

### Delete flash / memory card

It is not normally necessary to delete the memory.

Deletion produces a defined initial state on the memory media.

#### Note

If a memory card is inserted in the Touch Panel, this function deletes the contents of the memory card.

If no memory card is inserted in the Touch Panel, this function deletes the contents of the internal flash.

During the deletion process, all data is cleared from the data medium.

### Procedure for deleting

In order that the configuration on the TP is not deleted inadvertently, several separate touches are necessary simultaneously on the screen. Proceed as follows to delete the memory:

1. Touch the top left corner of the screen as the Touch Panel is starting up. The menu illustrated in figure 9-1 appears with the first confirmation request.

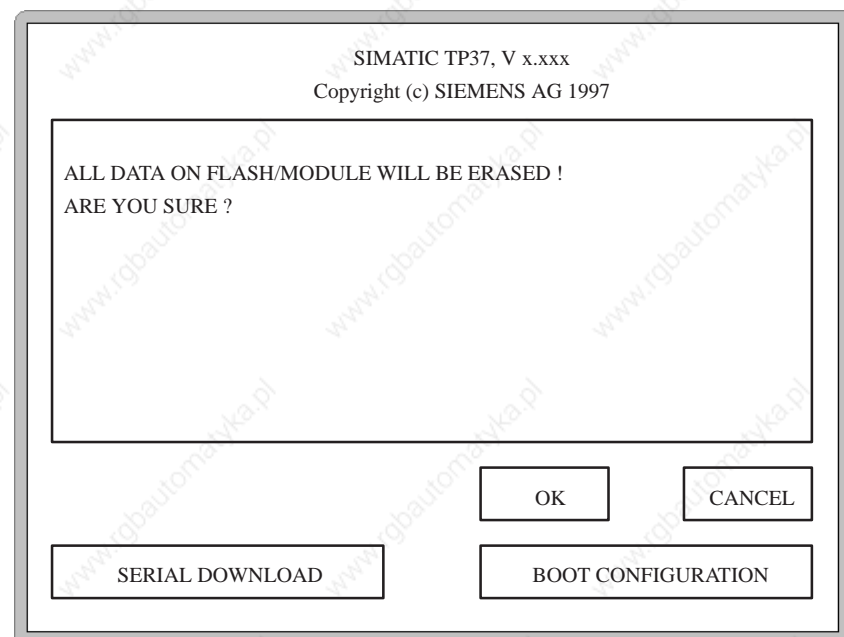

Figure 9-1 Settings in the startup phase (example: clear flash memory)

2. Touch the lower left corner area of the screen. When using the TP27–10, it is also necessary to touch the *OK* button. Touching any other area of the screen subsequently stops the deletion procedure.
3. Confirm the second confirmation request using the *OK* button.

### **Reserved memory area for recipe data**

A memory area, with the following default settings, is reserved for recipe data in the flash memory and on the memory card:

- 64 kB (flash memory)
- 128 kB (memory card).

If the default values are not sufficient, reset them in ProTool. Remember, however, that less space will be available for the configuration if the reserved area is enlarged.

---

### **Note**

Remember that, in addition to the reserved area for recipe data records, 64 kB are required on the internal flash memory and 128 kB on the memory card for management data.

---

## 9.3 Backup/Restore

### Application

The memory card offers the possibility of loading data stored in a Touch Panel directly onto a machine or system. This means that a configuration or recipe data records can be updated or modified irrespective of the location at which the system is being used.

A separate standard screen is provided for backup/restore with which the functions can be implemented.

### Standard screen

The standard screen *Backup/Restore* (figure 9-2) is opened from the *System Settings* standard screen on the Touch Panel by pressing the button 

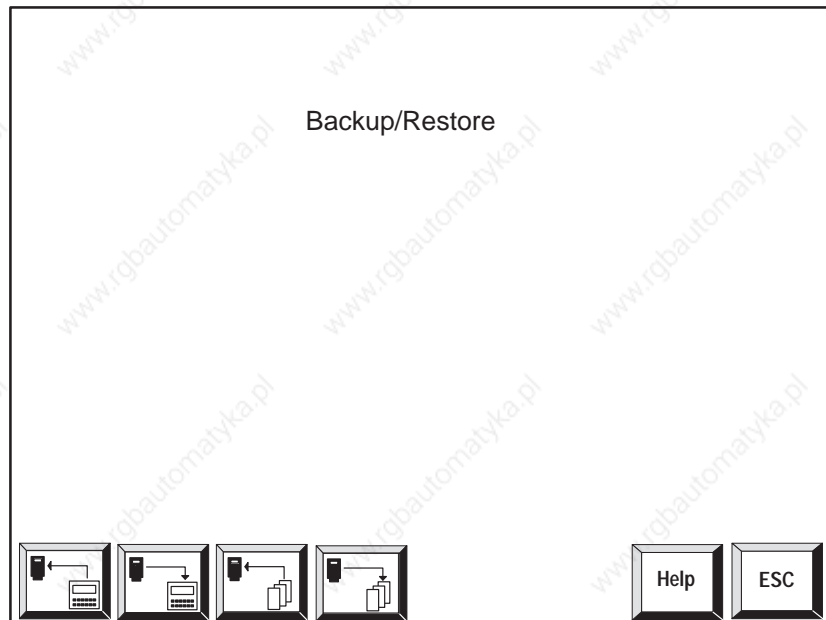

Figure 9-2 Standard screen *Backup/Restore*

### Meanings of buttons



**Backup:**  
Firmware + configuration + data records



**Restore:**  
Firmware + configuration + data records



**Backup:**  
Data records



**Restore:**  
Data records



Call Help text on standard screen



Exit from standard screen

**Insert memory card**

Use Slot B to plug the memory card into the TP37 and TP27–10. Only one slot is available in the TP27–6. The slot is described for TP37 in chapter 16.3, for TP27-10 in chapter 15.3 and for TP27-6 in chapter 14.3.

**Backup flash → module**

A backup flash → module process can be carried out in normal operation of the Touch Panel:

Step	Action
1	Insert the memory card in Slot B of the Touch Panel.
2	Delete the memory card contents before initiating the backup (see chapter 9.2).
3	Start the backup function by touching the corresponding button on the <i>Backup/Restore</i> standard screen. After successful transfer, a message is appears on the Touch Panel.
4	Remove the memory card from the Touch Panel.

**Restore module → flash**

If a memory card only contains recipe data records, they can be restored to the Touch Panel in normal operating mode:

Step	Action
1	Insert the memory card in Slot B of the Touch Panel.
2	Start the restore function by touching the corresponding button on the <i>Backup/Restore</i> standard screen. The recipe data records in the internal flash memory are overwritten by the data records read in from the memory card.
3	Remove the memory card from the Touch Panel.

**Note**

Recipe data records, stored on the memory card using Backup, must first be transferred to the internal flash using the Touch Panel with the Restore function before they can be edited.

Recipe data records, saved directly on the memory card (e.g. using standard screen *Data Record Processing and Transmission*), cannot be transferred back into the internal flash using Restore.

**Restore firmware/  
configuration**

Proceed as follows to restore a firmware/configuration backup on the Touch Panel:

Step	Action
1	Insert the memory card with the firmware/configuration in Slot B of the Touch Panel.
2	Restart the TP37. The Touch Panel starts up with the firmware/configuration contained on the memory card.
3	Start the restore function by touching the corresponding button on the <i>Backup/Restore</i> standard screen. The memory contents of the internal flash memory are overwritten by the firmware/configuration contained on the memory card.

**Load configuration  
in another unit**

In order to load the configuration on another unit which is not locally available, proceed as follows:

Step	Action
1	Firstly, download the configuration in the internal flash of the available unit.
2	Then transfer the configuration to the memory card (refer to procedure Backup flash → module).
3	Following that, load the file in the other unit according to the procedure Restore firmware/configuration.

**Note**

It is advised against downloading the configuration directly onto the memory card because the memory location organization differentiates between memory card and (target) flash which may lead to problems.

**Automatic restore  
firmware/  
configuration**

If the *Backup/Restore* function is added to “initialization” entry point in the configuration, the function is called in each time the Touch Panel is started up. The system then asks whether the internal flash memory should be overwritten by the data stored on the memory card.

Step	Action
1	Insert the memory card containing the backup into Slot B of the system.
2	Start up the Touch Panel.
3	Confirm that the restore function should be started by answering “OK” at the prompt.
4	Remove the memory card from the TP37.



## Status/Force Variable Using the TP

### Purpose

The Touch Panels provide two functions, namely *Status Variable* and *Force Variable*, which enable operand values from the connected PLC to be displayed in a standard screen and modified in a second screen.

This means that PLC operands can be edited directly on the TP in online mode without having to connect a programming unit to the PLC to do it.

### Status Variable

*Status Variable* enables the status of SIMATIC S5/S7 operands to be displayed.

### Force Variable

*Force Variable* enables SIMATIC S5/S7 operands to be controlled through modifying their values and transferring them back to the PLC.

## 10.1 Status Variable

### Standard screen Status Variable

The standard screen *Status Variable* is selected from the main screen using a soft key.



Status Variable						
MPI	Operand			Format		Value
12	DB, DBB	100	10	BIN =		0000000000000000
1	??????		0	????????		0
1	??????		0	????????		0
1	??????		0	????????		0
1	??????		0	????????		0
1	??????		0	????????		0
1	??????		0	????????		0
1	??????		0	????????		0
1	??????		0	????????		0
1	??????		0	????????		0

Status:  
Running

Figure 10-1 *Status Variable* standard screen (example: TP37 with SIMATIC S7)

### Significance of the operating elements

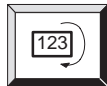

Start/Stop update



Call in help text concerning on the current screen



Exit from current screen

**Operands for SIMATIC S5**

Figure 10-2 illustrates the structure of a line for the SIMATIC S5 in the form of an example:

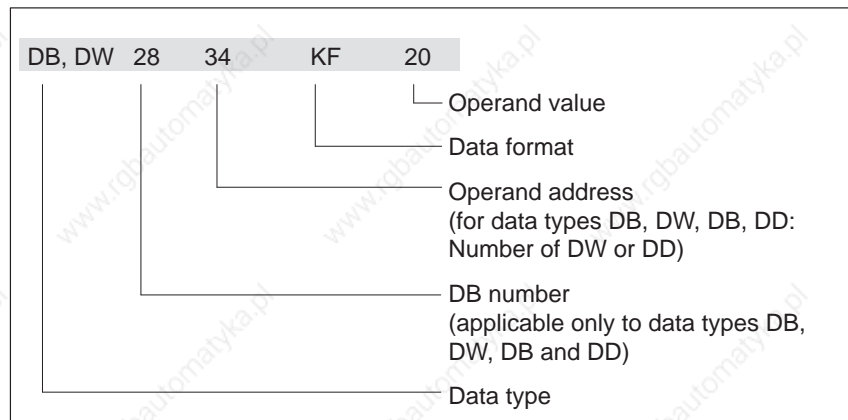

Figure 10-2 Display of PLC operands for the SIMATIC S5

**Operands for SIMATIC S7**

Figure 10-3 illustrates the structure of a line for the SIMATIC S7 in the form of an example:

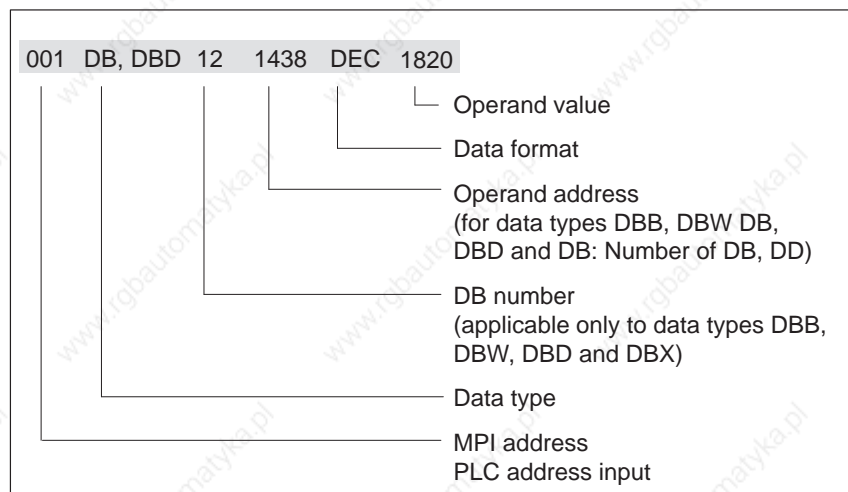
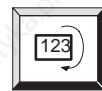
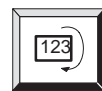

Figure 10-3 Display of PLC operands for the SIMATIC S7

**Control sequence**

Carry out the following steps to view operand values on the PLC:

Step	Action
1	<p><b>Enter operands</b></p> <p>Once the screen has been selected, status processing is at <i>Status Stop</i>. Proceed as follows:</p> <ol style="list-style-type: none"> <li>1. Call in the relevant screen for entering values by clicking on the first line.</li> <li>2. Enter the data type for the first operands.</li> <li>3. Enter the operand address for the first operands.</li> <li>4. Enter the dataformat for the first operands.</li> <li>5. Exit from the screen for entering values by clicking on button ESC.</li> <li>6. Repeat the entries for operands 2 to x.</li> </ol> <hr/> <p><b>Note</b></p> <p>A system message is issued if input is incorrect (e.g. the data format does not match the type entered). By default, the first entry in the pop-up window is then applied to the field.</p> <hr/>
2	<p><b>START updating</b></p> <p>Press the function key assigned to the icon depicted on the right, and set status processing to <i>Status Running</i>. The TP then displays the values of the operands in the final column of the standard screen. The display is updated cyclically.</p>
3	<p><b>STOP updating</b></p> <p>Press the function key again to stop updating and revert status processing to <i>Status Stop</i>.</p>



## 10.2 Force Variable

### Function

In addition to the function provided by *Status Variable*, operand values can be modified using the *Force Variable* screen ( $\hat{=}$ force).

### Standard screen: Force Variable

The *Force Variable* screen is not integrated in the ProTool standard screens and, therefore, must be assigned to a button in the configuration.

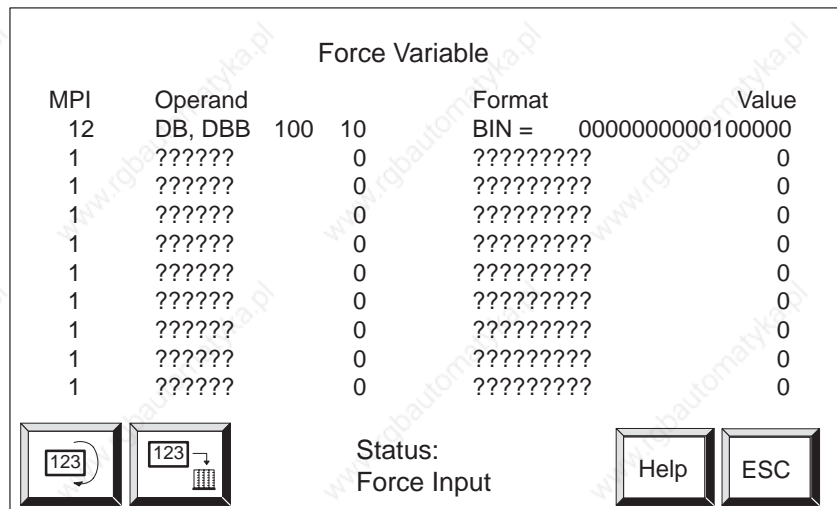
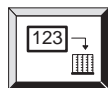

Figure 10-4 Force Variable standard screen (example: TP37 with SIMATIC S7)

### Significance of the operating elements



Start/Stop update



Force input/start







Call in help text concerning on the current screen



Exit from current screen

**Control sequence**

Carry out the following steps to control operand values:

Step	Action
1	<p><b>START updating</b></p> <p>Press the function key assigned to the icon depicted on the right and set status processing to <i>Status Running</i>.</p> 
2	<p><b>Force INPUT</b></p> <p>Switch status processing to the <i>Force Input</i> state using:</p> <p>Status processing is stopped and input is possible.</p> 
3	<p><b>Enter/modify operand value</b></p> <p>Proceed as follows:</p> <ol style="list-style-type: none"> <li>1. Select the line in which values need to be entered, thus calling in the corresponding screen for entering values.</li> <li>2. Enter the required values.</li> <li>3. Exit from the screen for entering values by clicking on the ESC button.</li> </ol>
4	<p><b>Force START</b></p> <p>Press the function key assigned to the icon on the right a second time:</p> <ul style="list-style-type: none"> <li>• all values of the operands assigned a change mark are transferred to the PLC</li> <li>• the change marks are reset, and</li> <li>• the system reverts automatically to status processing (Status: Status Running).</li> </ul> <p>or</p> <p><b>Cancel input</b></p> <p>Press the system key shown on the right.</p>   <p>Modified values are no longer transferred to the PLC after exiting from the <i>Force Tag</i> standard screen or switching to the <i>Updating in Progress</i> status.</p> 

## System Settings

### Standard Screen

The standard screen *System Settings* is used to configure functions which influence general Touch Panel settings. The following settings are possible:

- Blank screen
- Select language
- Initiate backup/restore,
- Adjust volume,
- Adjust contrast (TP27 only),
- Calibrate touch screen (TP37 and TP27-10 only)
- Deactivate touch screen (clean screen)
- Set TP mode
- Set parameters for messages
- Set date/time

Figures 11-1, 11-2 and 11-3 depict the standard *System Settings* screen for TP27-6, TP27-10 and TP37. Open the standard screen from the main screen by touching the button shown here.

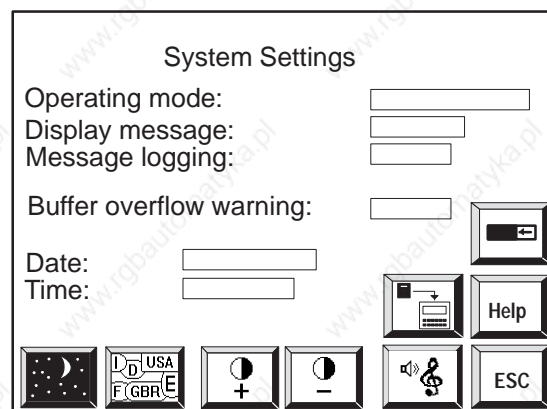
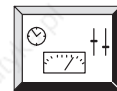

Figure 11-1 *System Settings* standard screen for TP27-6

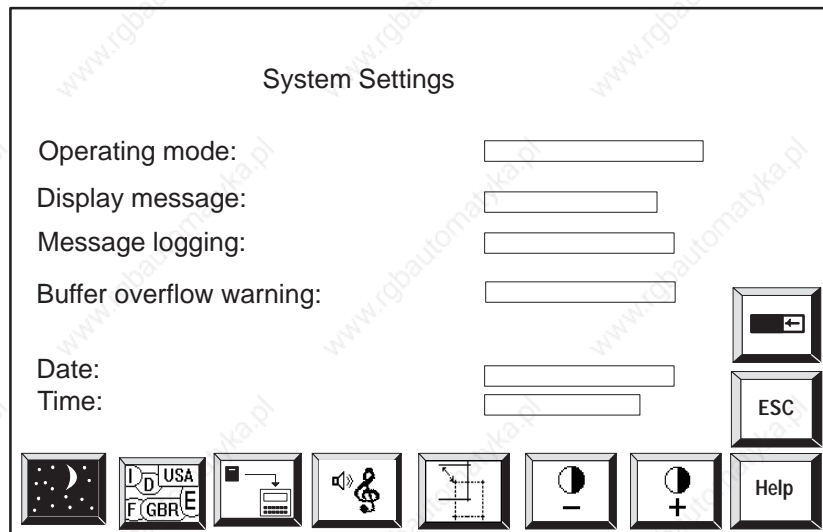

Figure 11-2 System Settings standard screen for TP27-10

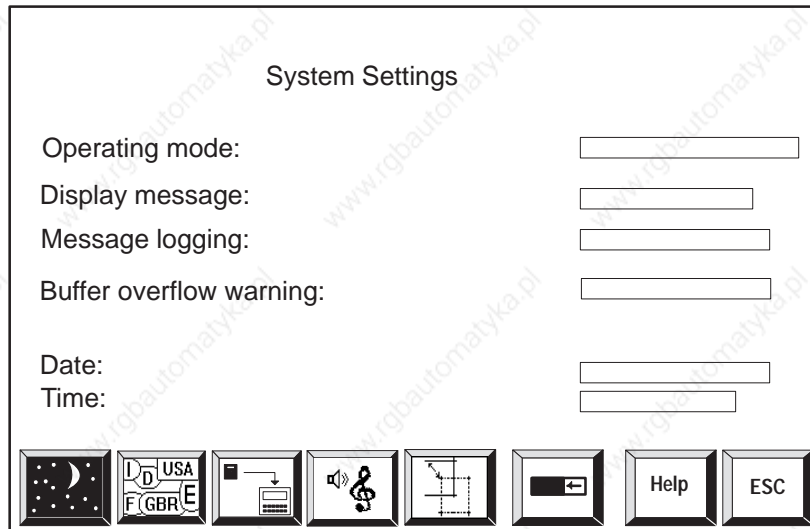

Figure 11-3 System Settings standard screen for TP37 and TP27-10

**Purpose of operating elements**

**Operating mode**

Set one of the following operating modes for the Touch Panel:

- Online
- Offline
- Transfer (Serial MPI)

**Display message**

For a description, refer to chapter 6

**Message logging**

For a description, refer to chapter 6

**Buffer overflow warning** For a description, refer to chapter 6

**Date and time**

Set current date and time of day



Blank screen



Switch language



Call Backup/Restore function  
(for a description, refer to section 9.3)



Adjust volume



TP27: Adjust contrast



TP37 and TP27-10:  
Calibrate touch screen



Deactivate touch screen to clean the screen  
(time limit)



Call Help text on standard screen



Exit from standard screen

## 11.1 Setting an Operating Mode

### Operating modes

The following TP operating modes can be adjusted:

- Online
- Offline
- Download
  - Serial
  - MPI (S7)

### Online

This is the standard operating mode for unrestricted process operation and process visualization. In Online mode, a logical connection is established between the Touch Panel and PLC or the Touch Panel attempts to establish a connection.

### Offline

In Offline mode, no logical connection is established between the Touch Panel and PLC. The Touch Panel does not attempt to establish a connection. You can use the Touch Panel. Process control and process visualization are not possible.

### Download

In Download mode, data can be downloaded from the configuration computer to the Touch Panel (refer to chapter 13.2). In this mode there is no logical connection between the PLC and the Touch Panel. You cannot operate the Touch Panel in Download mode.

### Changing the operating mode

- **In routine operation**

On the *System Settings* standard screen, touch the *Operating Mode* field and select the operating mode required from the selection window. The Touch Panel saves the current operating mode in the non-volatile memory. The next time it powers up, the Touch Panel automatically reactivates the operating mode last set.
- **During the startup phase of the Touch Panel**

The procedure for setting the Touch Panel to Download mode during the startup phase is described in section 13.2.

## 11.2 Blanking the Screen

### Purpose

The brightness of the LCD back-lighting is reduced during the course of time due to technological reasons. To extend its useful life:

- reduce the brightness of the back-lighting on the TP27,
- switch off the back-lighting on the TP37.

### Action

- **Trigger using the standard screen**

Touch the button depicted on the right of the *System Settings* standard screen. This blanks the screen.



As soon as you touch any part of the screen of the TP27, the back-lighting returns to full brightness; if you are using TP37 touching the screen switches on the back-lighting.

- **Automatic triggering**

If you do not touch the Touch Panel's screen within a configured period of time, the screen is blanked automatically. As soon as you touch any part of the screen of the TP27, the back-lighting returns to full brightness; if you are using a TP37 touching the screen switches on the back-lighting.

The screen of the Touch Panel is only blanked automatically if this function has been configured in ProTool.

## 11.3 Deactivate Touch Screen

### Purpose

Soiling the touch screen cannot be avoided during normal operation. Therefore, it should be cleaned at regular intervals. In order to prevent functions being activated inadvertently while cleaning the screen, it can be deactivated via the *System Settings* screen for a limited period of time.

### Procedure

Touch the button depicted on the right in the *System Settings* screen. The screen is blanked and a bar graph appears.

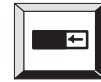

The touch panel is then deactivated for 30 seconds. It can be cleaned without any functions being triggered. The way to clean the touch panel is described in section 18.1.

The bar graph on the screen constantly indicates the remaining time until the touch panel is reactivated. The standard screen reappears automatically after 30 seconds.

If this function is used in a customized configuration, the time period of deactivation can be changed.

## 11.4 Calibrating the Touch Screen (TP37 and TP27-10 only)

### Purpose

Depending on the installation position and viewing angle, it is possible that when operating the TP37 and TP27-10 one or more parallel axes appear, some more some less strongly highlighted. To prevent any operating errors occurring as a result of this, the TP37 and TP27-10 screens can be calibrated using the *System Settings* standard screen. The *Touch Calibration* function is protected by a password.

### Action

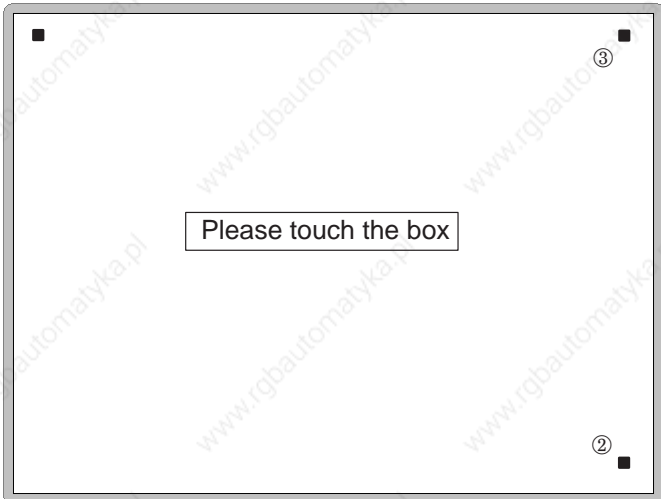
Step	Action
1	On the <i>System Settings</i> standard screen, touch the button 
2	Enter the supervisor password in the password window.
3	Three calibration boxes appear one after the other on the screen in the sequence given in the figure below. Follow the prompt and touch the calibration box currently visible. <div data-bbox="635 909 1299 1406" style="border: 1px solid black; padding: 10px; margin: 10px 0;">  </div>
4	<p>The Touch Panel checks whether two of the positions touched are in line.</p> <ul style="list-style-type: none"> <li>• When this condition is satisfied, the screen is calibrated and the <i>System Settings</i> standard screen reappears.</li> <li>• If the condition is not satisfied, an error message is issued and the user is prompted to repeat Step 3.</li> </ul> <p>With the TP37 and TP27-10, calibration is saved even in the event of a power failure.</p>

### Tip

If calibration is not correctly performed, TP37 and TP27-10 may not be operable in the case of extreme adjustments. In this case, restart the TP and repeat the touch calibration. Any extreme calibration error is corrected by default values which are restored on restarting.

## 11.5 Other Settings

### Date/Time

The current date and time can be set on the Touch Panel in order, for example, to make adjustments for summer and winter time. Any change affects all the fields which display a date and time variable. The display format for date and time is set in the configuration and cannot be changed later on the Touch Panel.

**Procedure:**

Touch the *Date* or *Time* field in the *System Settings* standard screen. Enter the current values in the correct format in the edit window. Enter the periods as well.

The Touch Panel saves the current date and time in the non-volatile memory.

### Language

The configuration can be loaded onto the Touch Panel in up to three languages. It is possible to switch to any of the languages at any time in Online mode. After switching to another language, all passages of language-dependent text are displayed in the new language.

**Procedure:**

Touch the button depicted on the right on the *System Settings* standard screen. The languages are scrolled, one by one, each time the button is pressed.

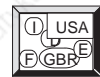

The Touch Panel saves the current language setting in non-volatile memory. The next time the Touch Panel is switched on all the language-dependent text passages are displayed in the last language you set.

### Adjusting volume

The Touch Panel acknowledges contact with a touch element by issuing an acoustic signal. This signal takes the form of a tone audible while contact is made. The procedure for adjusting the volume of this audible tone online is as follows:

- TP27: “high”, “low” or “off”,
- TP37: “ON” or “OFF”.

**Procedure, TP27:**

The default setting is “high” volume. Each time the button on the right is touched in the *System Settings* standard screen, the volume is adjusted, cyclically, to the next setting: High → Off → Low → High.



**Procedure, TP37:**

The default setting is signal tone ON. Touch the button shown here in the *System Settings* standard screen to switch off the signal tone. Toggle between signal tone ON and OFF by repeatedly touching the button.



The volume can also be adjusted by means of the potentiometer on the underside of the housing (see section 13.2).

**Note**

The signal tone is independent of communication with the PLC. It does not indicate that the required action has actually been executed.

**Contrast**

The TP27 has two buttons with which to adjust the contrast of the screen display in Online mode.

**Increase contrast :**

Touch the button depicted on the right on the *System Settings* standard screen. Each time the button is pressed, the contrast is increased by one level.

**Reduce contrast :**

Touch the button depicted on the right on the *System Settings* standard screen. Each time the button is pressed, the contrast is reduced by one level.



Apart from using these two buttons, the contrast can also be adjusted via the Boot window (refer to chapter 13.2).



# **INSTALLATION AND COMMISSIONING**

**12 Installation**

**13 Commissioning**

# **Part III**



## Installation

### Installation location and conditions

The Touch Panels TP27 and TP37 are designed for vertical installation in the front panels of switching cabinets. Cut a mounting slot in the front panel in preparation for installation of the Touch Panel. The thickness of the front panel must not exceed 6 mm. No other holes need to be drilled for mounting.

Details regarding the mounting depth and mounting slot are provided in chapter 14.

### Degree of protection

The IP65 degree of protection for the front panel can only be ensured when the seal on the front plate of the Touch Panel is fitted correctly.



---

### Caution

- The TP must be brought to room temperature before it is commissioned. If condensation forms, do not switch on the TP until it is absolutely dry.
  - To prevent the Touch Panel from overheating during operation,
    - the angle of inclination specified in the technical data must not be exceeded,
    - do not expose the TP to direct sunlight
    - ensure that the ventilation slits in the housing remain free after installation.
  - When the cabinet is opened, certain parts of the system that may conduct hazardous voltage are exposed.
  - The TP was function-tested before shipping. If a fault occurs nevertheless, please enclose a full account of the fault when returning the TP.
-

## 12.1 Mechanical Installation

### How to install the TP27-6

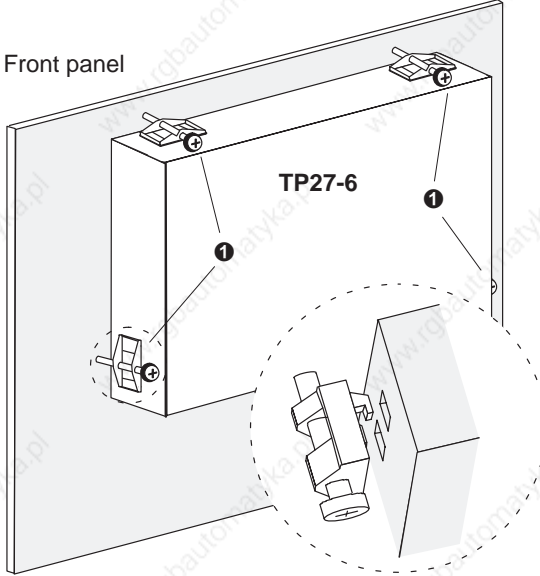
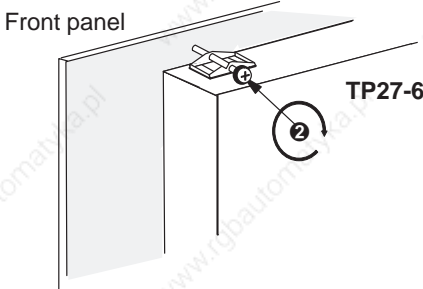
Step	Action
1	<p>Slide the enclosed seal from the rear over the housing and, working from the front, install the TP27-6 in the mounting cutout prepared.</p> <p>Make sure the TP cannot drop out of the front panel before it has been secured.</p>
2	<p>Place the hooks of the five screw-type clamps enclosed ❶ in the corresponding recesses in the housing of the TP27-6.</p> 
3	<p>Use a screwdriver to tighten the TP27-6 from the rear in the front panel ❷.</p> <p>Note:</p> <ul style="list-style-type: none"> <li>– Make sure the seal is seated correctly against the front panel.</li> <li>– Do not overtighten the screws to avoid damage.</li> </ul> 

**How to install the TP27-10**

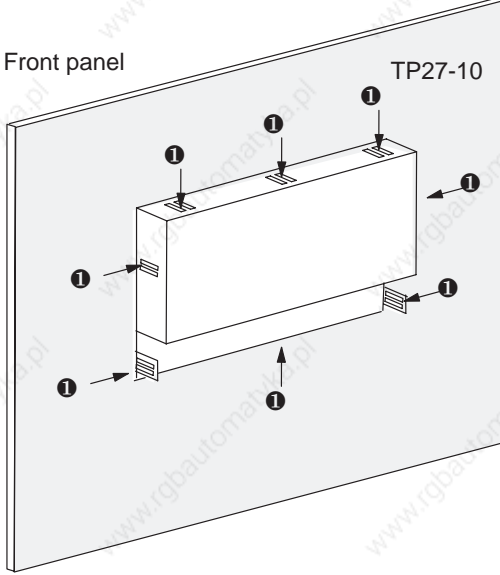
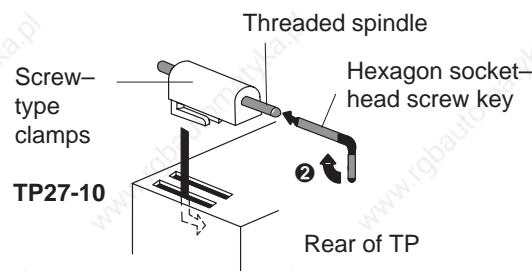
Step	Action
1	<p>Install the TP27-10 from the front in the pre-prepared mounting cutout.</p> <p>Ensure the TP cannot drop out of the front panel before it has been secured.</p>
2	<p>Place the hooks of the screw-type clamps enclosed ❶ in the corresponding recesses in the housing of the TP27-10.</p> 
3	<p>Tighten the TP27-10 to the front panel ❷, from the rear, using a hexagonal socket-head screw key.</p> <p>Note:</p> <ul style="list-style-type: none"> <li>– Do not overtighten the screws, maximum: <b>0,5 Nm</b>.</li> </ul> 

For mounting into a front panel, the TP27-10 must be fixed using screw-type clamps. Too high torques when tightening the threaded spindle may distort the equipment housing and, as a result, cause breaking of the Touch Screen.

**Maximum torque**

It must be ensured that the threaded spindles of the screw-type clamps are tightened with the recommended torque of **0,5 Nm**.

**Seal**

After correct fixing of the equipment, the seal remains visible owing to construction reasons.



---

**Caution**

Do not try to upset the seal until the TP27-10 and the front panel lie on each other at the same level.

Any damages caused by too high torques when tightening the screw-type clamps of the TP27-10 are not covered by the warranty.

---

**How to install the TP37**

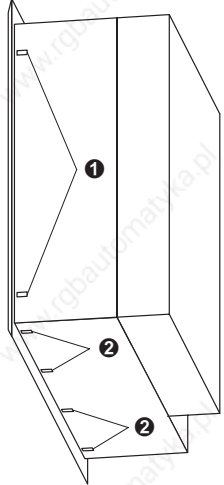
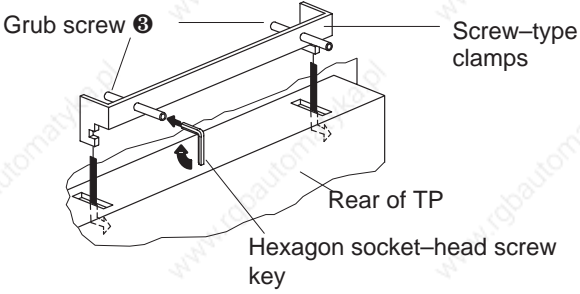
Step	Action
1	<p>Working from the front, position the <b>TP37</b> in the slot cut in the cabinet.</p> <p>Make sure the TP cannot drop out of the front panel before it has been secured.</p>
2	<p>Locate the hooks of the six screw-type clamps enclosed with the TP in the corresponding recesses in the housing of the <b>TP37</b>.</p> <p>One large screw-type clamp <b>1</b> is required on the left and another on the right, two small screw-type clamps <b>2</b> for the top and two for the bottom.</p> 
3	<p>Working from behind, tighten the grub screws <b>3</b> against the front panel, as illustrated.</p>  <p><b>Note:</b></p> <ul style="list-style-type: none"> <li>• Make sure the seal is seated correctly against the front panel.</li> <li>• Do not overtighten the screws to avoid damage.</li> </ul>

## 12.2 Electrical Installation

### Electrical connections

The Touch Panel requires electrical connections

- to the power supply,
- to the configuration computer (PU or PC),
- to the PLC.

The electrical connection to the PU or PC is required purely for downloading the firmware and configuration. Following the configuration and test phases, a serial printer can be connected to the Touch Panel instead of the configuration computer.

### EMC compatible design

A precondition for error-free operation is an EMC compatible hardware design of the PLC and the use of interference-proof cables. The guidelines on interference-free design of the PLCs apply equally to installation of the Touch Panel.



### Caution

- Only shielded cables are allowed for all signal connections.
  - Screw or lock all plug connections.
  - Do not install signal lines in the same cable ducts as power cables.
  - Siemens AG refuses to accept liability for malfunctions and damage arising from use of self-made cables or cables from other manufacturers.
- 

### Reverse battery protection

The operating units have reverse battery protection. This has no effect if a connection already exists to another unit via RS 232. Therefore, proceed as follows when commissioning the operating unit:

1. Connect the power supply.
2. Switch on the operating unit. If the operating unit does not power up, swap the connections because the poles are reversed.
3. When the operating unit has been powered up, connect the configuration computer or periphery equipment.

**Configuration options**

Figure 12-1 illustrates a number of configuration options for Touch Panels, PLCs and periphery equipment.

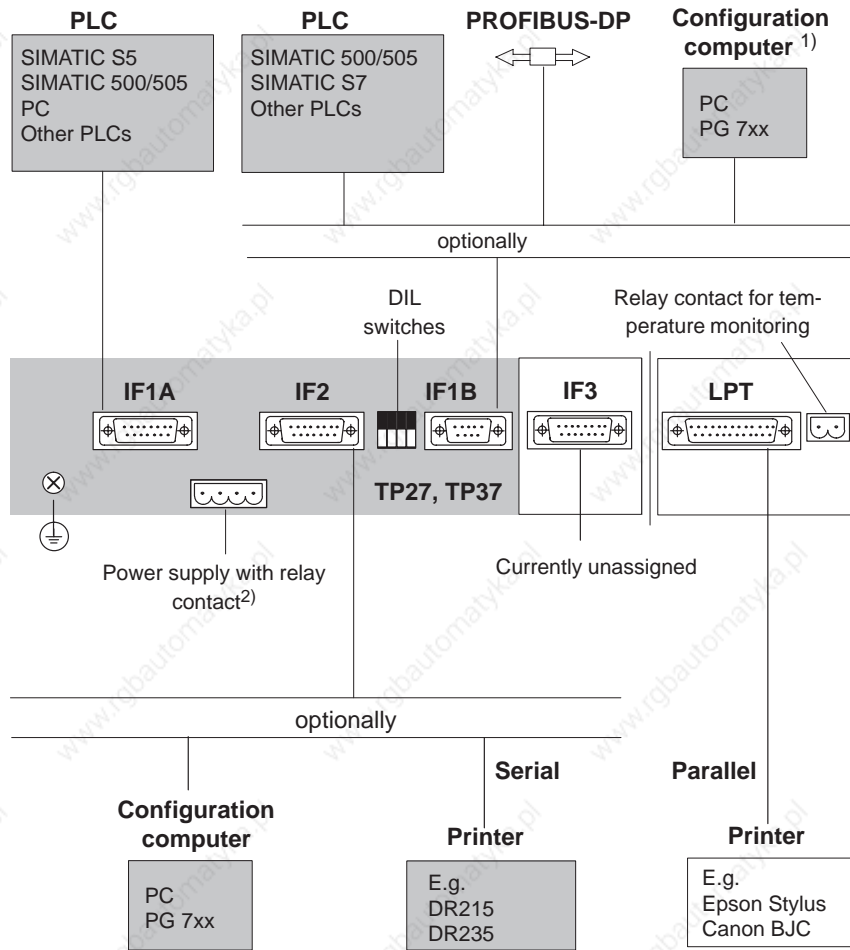

Figure 12-1 Configuration options

Detailed information on connection options is provided in the sections below. The connection plug pin assignment for the interfaces are provided in Appendix B of this manual.

## 12.2.1 Power Supply and Relay Contacts

### Power supply

The power supply for the Touch Panel is connected at the 4-pin plug connector on the underside of the unit. Use the 4-pin terminal block supplied with the TP for this purpose. The terminal block is designed for cables with a cross-section not larger than 2.5 mm<sup>2</sup>. Please refer to the technical data in Appendix A of information on the power supply requirements.

### Relay contacts (TP27-6 and TP37) only

When configured accordingly, messages on the Touch Panel can trigger visual and acoustic signals (lights, flashing lights, buzzer, sirens etc.) by tripping an internal relay. The relay contacts are also carried to the 4-pin plug connector.

The figure below illustrates assignment of the 4-pin plug connector for the power supply and relay contacts.

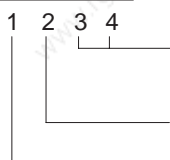

Relay contacts (NO contacts)  
 Rating 24 V DC; 0.4 A  
 (no inductive load)  
 GND  
 + 24 V DC



### Caution

- With a 24 V supply, make sure that the extra-low voltage is isolated safely. Use only power supply units complying with IEC 364-4-41 or HD 384.04.41 (VDE 0100, Part 410).
- The supply voltage must be within the specified voltage range. Voltages outside this range can cause malfunctions.

### Temperature monitoring ( TP37 only)

A sensor monitors the temperature on the inside of the **TP37**. The contacts of the internal relay close if the temperature exceeds the permissible limit value. The relay contacts are carried to a 2-pin plug connector. This connector can be used to drive an external fan, for instance.

The figure below illustrates the assignment of the 2-pin plug connector.



Relay contacts (NO contacts)  
 Rating 24 V DC; 0.4 A  
 (no inductive load)

### Ground connection

Connect the ground connection  of the unit to the cabinet ground. To do so, use the grounding screwdriver supplied.

## 12.2.2 Connecting the Configuration Computer

### Connection configuration

In order to download the configuration, a connection between the configuration computer (PU or PC) and TP must be established. There are two connection options available for this:

- the serial connection of a configuration computer to the TP interface IF2 (serial downloading),
- the connection of a configuration computer to the TP interface IF1B (MPI downloading). In this case, the configuration computer and TP are connected to the MPI network. A condition for this is that a configuration already exists on the TP.

Both connections serve for downloading the firmware and configuration data (chapter 13.2). Standard cables are available for the connections shown (refer to the ST80.1 catalog).

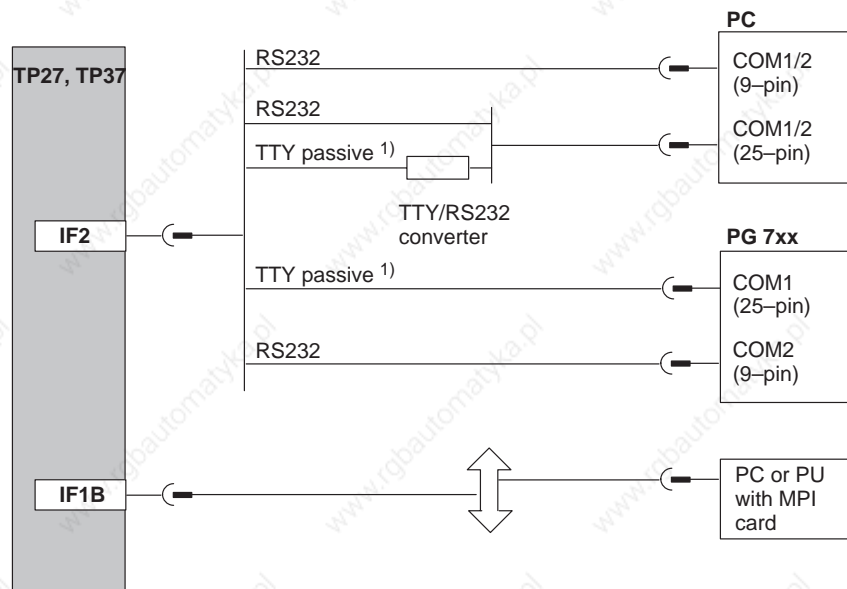

- 1) Do not use the Siemens converter cable for connection by TTY/passive, because the Touch Panel does not supply 5 V.

Figure 12-2 Connection configuration diagram for configuration computer

### 12.2.3 Connecting the PLC

#### Connection configuration

Figure 12-3 illustrates the basic connection possibilities between the TP27, TP37 and PLC. Standard cables are available for the connections shown (see the ST80.1 catalog).

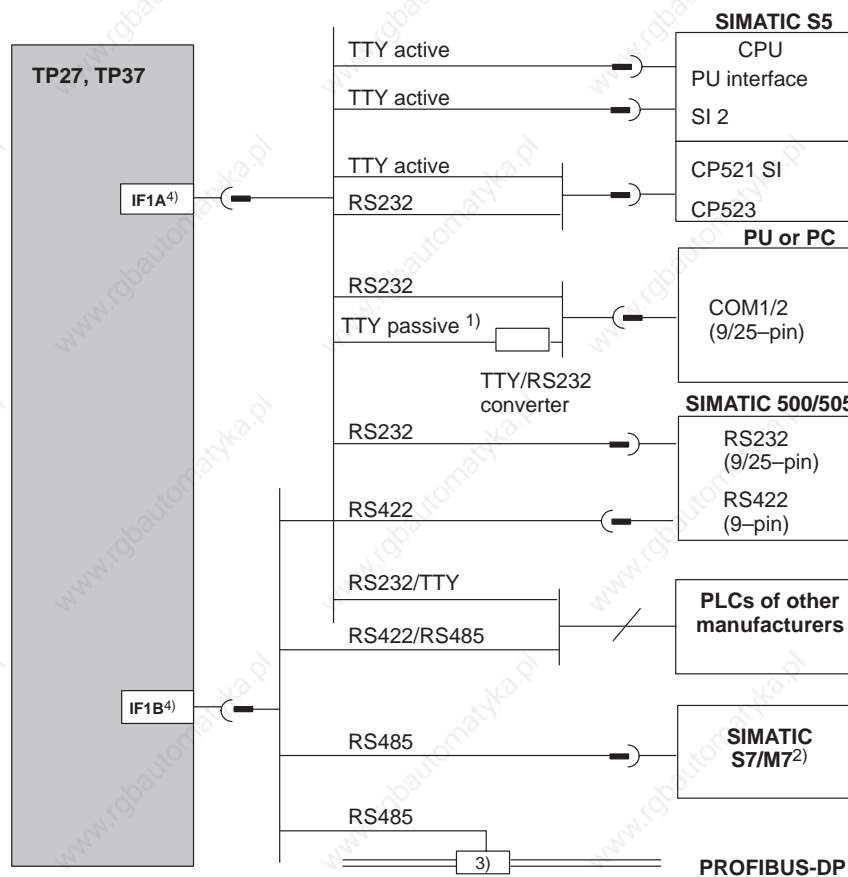





- 1) Do not use the Siemens converter cable for connection by TTY/passive, because the Touch Panel does not supply 5 V.
- 2) Use only the approved cables for connection to SIMATIC S7/M7.
- 3) Any PROFIBUS-DP bus terminal (except FSK)
- 4) For operation via the serial interface, connect either IF1A (RS232/TTY) or IF1B (RS422/485), but not both. The IF1B interface is configured by means of DIL switches.

Figure 12-3 Connection configuration diagram for PLCs

**Configure interface IF1B**

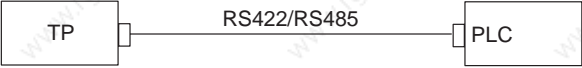
The IF1B interface can be configured by using the DIL switches, located beside the 9-pin Sub-D connector. This interchanges the RS422 receive data and the RTS signal. By default, the RTS signal is not required by the communication peer.

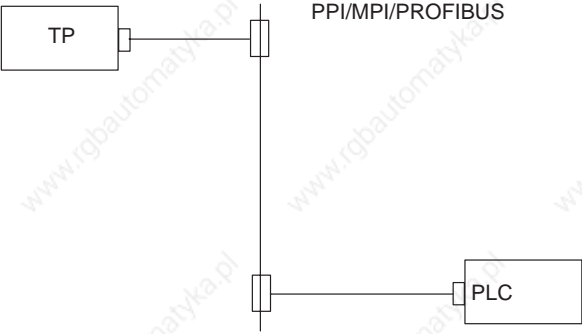
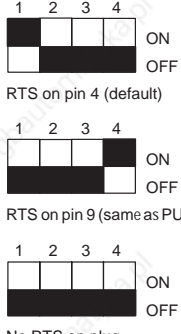
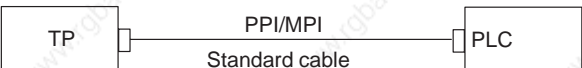
The table shows the permissible DIL switch settings.

Communication	Switch Setting
	
	
	

## 12.2.4 Connecting a Printer

### Connection configuration

Figure 12-4 illustrates the connection of a printer to the serial and parallel printer interfaces of the Touch Panel:

- Serial connection: **IF2**
- Parallel connection: **LPT (TP37 only)**

Cables with integral connectors are available for connecting Siemens printers (refer to the ST80.1 catalog). When connecting printers from other manufacturers, use the cables supplied or specially made cables.

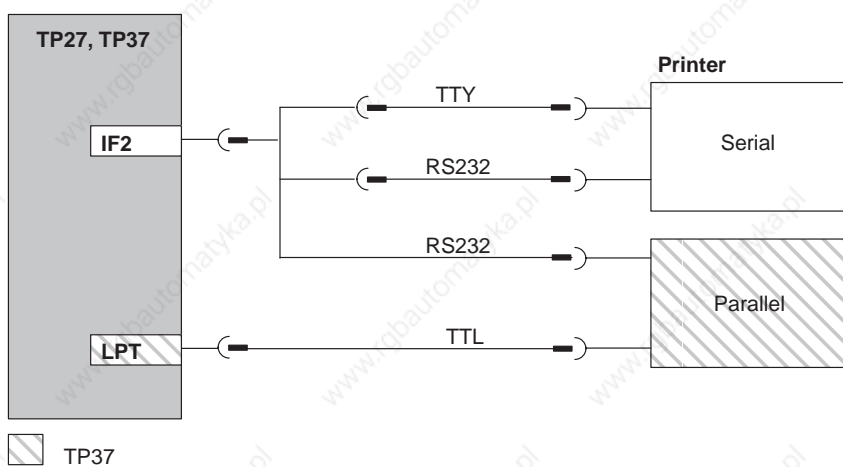

Figure 12-4 Connection configuration diagram for printers

### Note

Use only a cable with braided metal shield grounded at each end for connecting the Touch Panel and the printer.

### Printer settings

The printer type and transmission parameters are defined on the Touch Panel via standard screen *Printer Settings* (refer to chapter 7).

Some printers may require defining the ASCII character set used in the configuration on the printer as well.

# 13

## Commissioning

### Flowchart

The guide to commissioning, depicted below, describes the individual steps required for commissioning Touch Panels TP27 and TP37. Figure 13-1 illustrates the most important steps for the initial startup, recommissioning and normal operation of the Touch Panels.

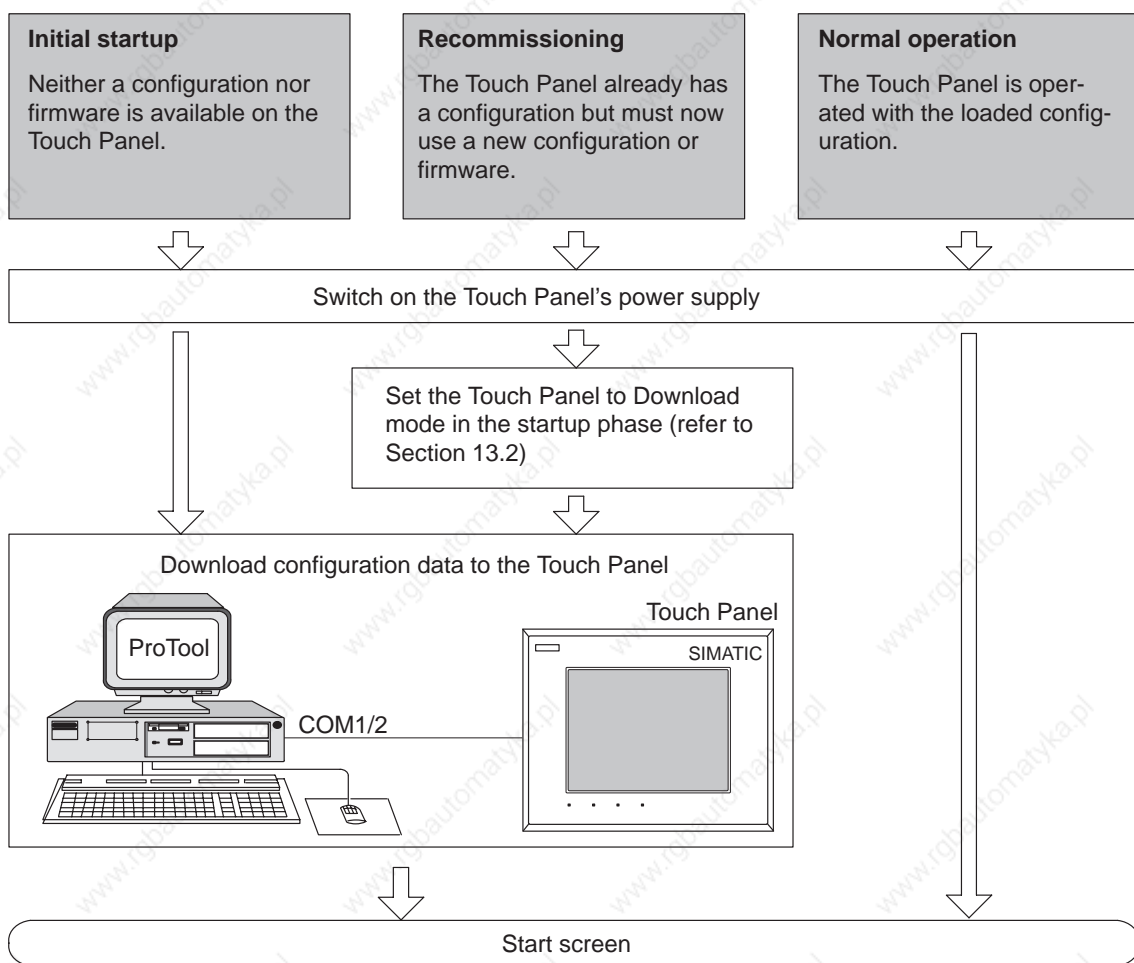

Figure 13-1 Commissioning flowchart

**Before  
commissioning**



Before commissioning the Touch Panel please observe the following:

---

**Caution**

- With the SIMATIC S5, compression of the internal program memory on the PLC (PU “Compress” function, integrated FB COMPR) is not allowed when a Touch Panel is connected. Compression modifies the absolute addresses of the blocks in the program memory. As the Touch Panel reads the address list only during startup, it does not detect any address modifications and accesses the wrong memory areas.

If compression is inevitable during routine operation, switch off the Touch Panel prior to compression.

- In hazardous areas, always de-energize the Touch Panel before unplugging connectors.
- 

**Note regarding TP  
start-up**

Do not touch the screen of the Touch Panel until after the initialization phase when the menu illustrated in figure 13-2 or figure 13-3 appears.

The signal tone is not active during startup.

## 13.1 Initial Startup

### Procedure

The firmware and configuration must be downloaded to the Touch Panel when it is started up for the first time.

All the units in the SIMATIC HMI family are equipped with reverse battery backup. The reverse battery backup is not effective if a connection to the configuration computer already exists to download the generated project.

For this reason, the following procedure is absolutely essential for downloading and commissioning the unit:

Step	Action
1	<p>Switch on the Touch Panel's power supply. Since a configuration has yet to be loaded at this stage (and no PCMCIA card has been inserted in another unit, refer to chapter 9.3, <i>Load configuration in another unit</i>), the Touch Panel automatically enters Download mode, displaying the message</p> <p style="text-align: center;">"READY FOR SERIAL TRANSFER"</p> <p>and waits for data to be downloaded from the PU or PC (see figure 13-3).</p> <p>The Touch Panel cannot be operated in Download mode.</p>
2	<p>Connect the IF2 interface (RS232/TTY) on the Touch Panel to the PU or PC by means of a suitable standard cable.</p>
3	<p>Start the download operation on the PC or PU to the TP27, TP37. The Touch Panel checks the connection to the PC or PU. If the connection is not available, or if it is not functioning correctly, the Touch Panel issues the corresponding error message.</p> <p>If the connection is in order, downloading of the configuration commences. The Touch Panel's firmware is downloaded automatically.</p> <p>Following successful downloading, the Touch Panel restarts and displays the start screen of the configuration that has just been loaded.</p>

### Note

Please refer to the ProTool for information on which settings are required for the downloading operation in *User's Guide ProTool Configuring Graphic Displays*.

## 13.2 Recommissioning

### Types of downloading

When recommissioning, the configuration/firmware already loaded in the Touch Panel is replaced by another. Downloading can be performed by means of

- serial download or
- MPI download (for SIMATIC S7).

### Serial download

In the case of a serial downloading operation, the configuration/firmware is transferred from the PC/PG to the Touch Panel via an RS232/TTY connection. Begin by connecting the IF2 interface (RS232/TTY) on the Touch Panel to the PU or PC using a suitable standard cable.

There are two ways of setting the Touch Panel to Download mode:

- **In routine operation**  
The method of changing the *operating mode* of the Touch Panel online is described in Section 11.1.

- **In the startup phase of the Touch Panel**

In the startup phase of the Touch Panel, the menu illustrated in figure 13-2 or figure 13-3, as appropriate, appears briefly in the initialization phase. Touch the *SERIAL DOWNLOAD* button to set the Touch Panel to Download mode before power up.

Providing the download operation to the Touch Panel has not started, you can exit the Download mode by touching the *BOOT CONFIGURATION* button to continue the boot operation.

Following a successful download operation, the Touch Panel powers up with the new configuration and/or firmware and displays the start screen of the configuration that has just been loaded.

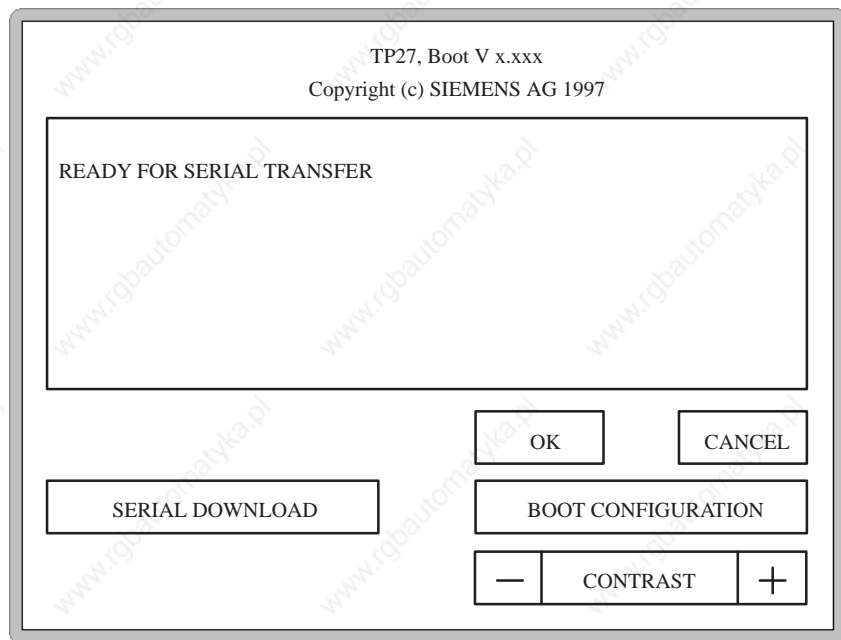
Figure 13-2 TP27 in *Serial Download*

Before downloading to a TP27, the display contrast can be adjusted in the Boot window by pressing the CONTRAST - and CONTRAST + fields.

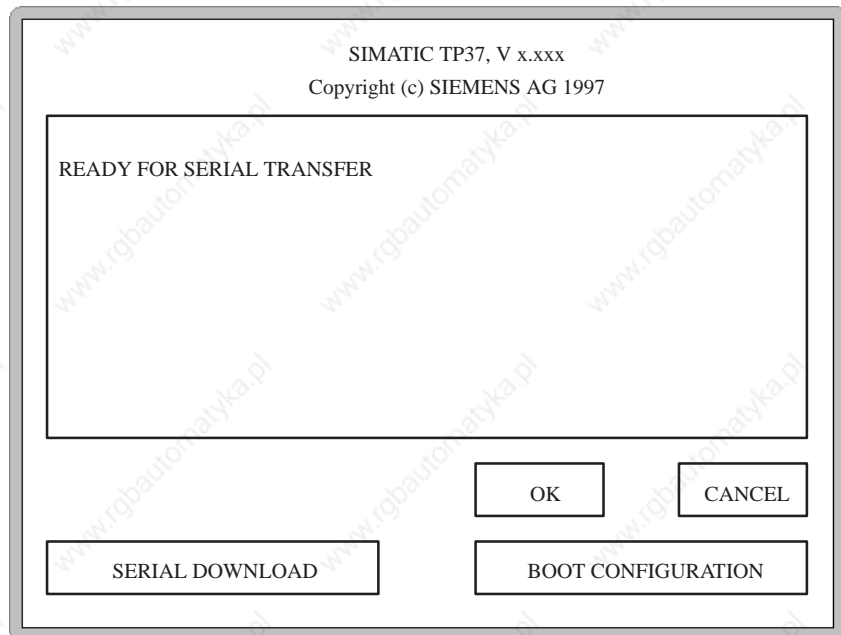
Figure 13-3 TP37 in *Serial Download*

**MPI download**

If a configuration is already loaded for the SIMATIC S7 on the Touch Panel, other S7 configurations can be downloaded to the Touch Panel via an MPI connection.

Step	Action
1	Switch on the Touch Panel's power supply.
2	Connect the IF1B interface on the Touch Panel to the PC or PU using a standard cable. If the Touch Panel and PC or PU have been incorporated on the MPI bus, the cables need not be switched for the download operation.
3	In the <i>System Settings</i> standard screen, touch the <i>Operating mode</i> field and select <i>MPI Download</i> from the selection window.  The Touch Panel restarts, shows the menu illustrated in figure 13-4 and waits for data to be downloaded from the PU or PC.
4	Providing data is not being downloaded to the Touch Panel, it is possible to <ul style="list-style-type: none"> <li>• exit from the MPI download operation by touching the <i>BOOT CONFIGURATION</i> button and performing the boot operation</li> <li>or</li> <li>• start the serial download operation by touching the <i>SERIAL DOWNLOAD</i> button.</li> </ul>
5	Before data is downloaded, touch the <i>MPI baud rate</i> input field, if necessary, and select a baud rate between 9.6 kbaud and 1.5 Mbaud from the selection window.
6	Start the download operation on the PC or PU to the /Touch Panel. The procedure is described in the <i>User's Guide ProTool – Configuring Graphics Displays</i> .  The Touch Panel checks the connection to the PC or PU. If the connection is not available or if it is not functioning correctly, the Touch Panel issues a corresponding error message. If the connection is in order, downloading of the configuration and or firmware commences.  Following successful downloading, the Touch Panel restarts and displays the start screen of the configuration that has just been loaded.

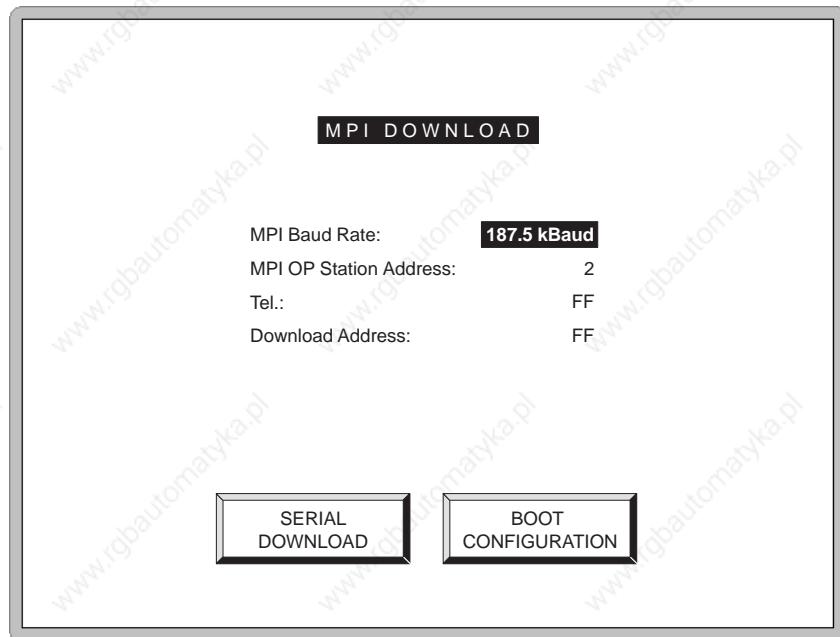

Figure 13-4 Touch Panel in *MPI Download mode*

### Fault diagnosis

A fault occurring during commissioning or operation is normally displayed on the Touch Panel by means of a system message.

Appendix C of this manual contains a list of some of the most important system messages and explanations on how to eliminate them.

### Data backup

The operating data of the Touch Panel (tag values, message buffer) is stored in a buffered SRAM and retained even in the event of a power failure. Operating data is not lost if the power supply is turned off or fails.

### 13.3 Startup Behavior

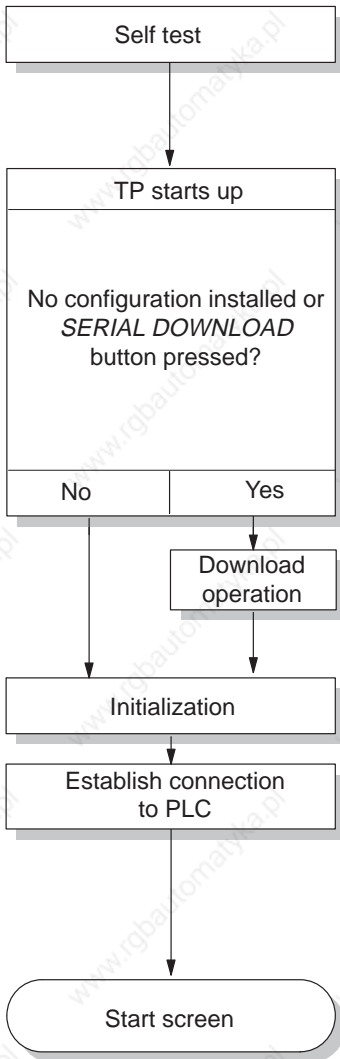

After the power supply has been switched on, the Touch Panel performs a self test. During the test, it checks the operability of the most important TP components and displays the test results. The test results are then deleted.

If a configuration is not present on the Touch Panel, it automatically enters Serial Download mode.

The Touch Panel then performs various internal initializations.

During the startup phase, the Touch Panel attempts to establish a connection to the PLC.

If communication is not possible – for example, because the cable to the PLC has not been connected – the Touch Panel displays a system message.

Following startup, the Touch Panel displays the configured start screen.

## 13.4 Testing a Configuration in OFFLINE Mode

### Purpose

In operating mode *OFFLINE*, individual functions and configurations downloaded from the PC/PG to the Touch Panel can be tested without being influenced by the PLC. PLC tags are not updated in OFFLINE mode.

### Action

Step	Action
1	Set the TP27, TP37 to <i>OFFLINE</i> mode using the <i>System Settings</i> standard screen.
2	Check all the configured screens in respect of correct presentation.
3	Check the screen hierarchy.
4	Check the input fields.
5	Test the buttons.

### End of test

If faults occur when executing the individual steps, download the configuration again.

## 13.5 Testing the Configuration in Conjunction with the PLC

### Test with PLC connected

If the tests have been successfully performed in Offline mode, test the TP27, TP37 in conjunction with the connected PLC. This checks that the correct data areas have been configured.

Step	Action
1	Connect the TP27, TP37 to the PLC. A message on the TP27, TP37 indicates that it has been connected successfully.
2	Acknowledge this message.
3	<p>Set the TP27, TP37 to <i>ONLINE</i> mode using the <i>System Settings</i> standard screen.</p> <p>All the items contained in the configuration that are necessary for communication with the PLC can then be tested. Depending on the configuration, these might be:</p> <ul style="list-style-type: none"><li>• event and alarm messages</li><li>• buffers for event messages and alarm messages</li><li>• print functions</li><li>• automatic message logging</li><li>• selecting screens etc.</li></ul>

# **DEVICE DESCRIPTION AND MAINTENANCE**

# **Part IV**

- 14 Device Description TP27–6**
- 15 Device Description TP27–10**
- 16 Device Description TP37**
- 17 Options**
- 18 Maintenance/Upkeep**



## Unit Description TP27-6

### In this chapter

This chapter provides information on:

- dimensions
- operating and display elements
- connection elements and
- communication options

of Touch Panel TP27-6.

### 14.1 Dimensions

#### Unit dimensions

The following figure indicates the dimensions of the TP27-6 with the housing of the direct key module/control panel which is available on option.

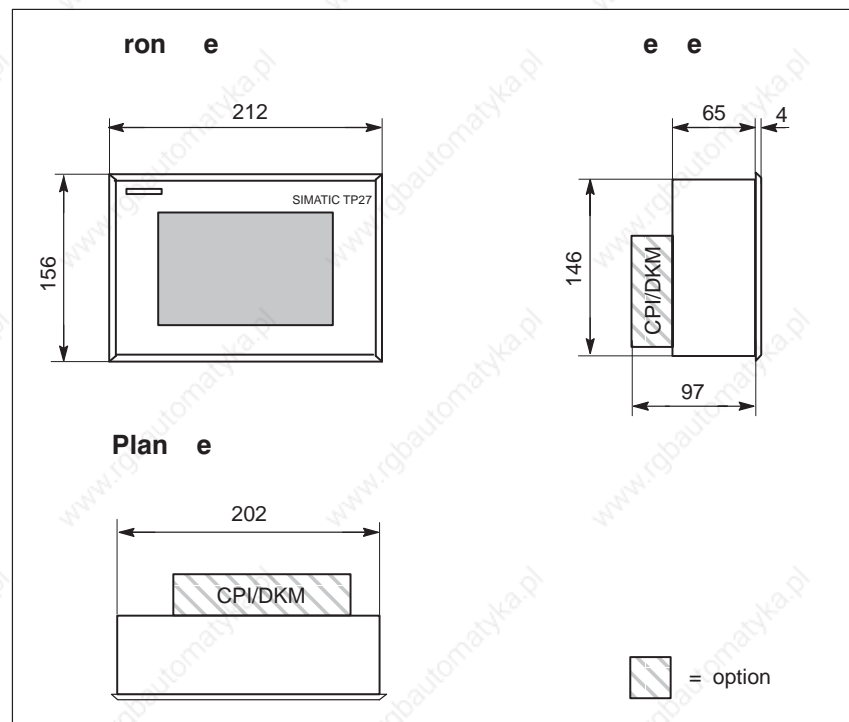

#### Mounting cutout

The TP27-6 requires a mounting cutout (WxH) of  $203^{+1}$  mm x  $147^{+1}$  mm.

## 14.2 Operating elements

### Touch screen

The TP27-6 touch screen is used to operate and monitor processes. Operation is effected by means of contact-sensitive buttons and input fields which are defined in the configuration for a specific application. No additional keyboard is necessary.

## 14.3 Connection elements

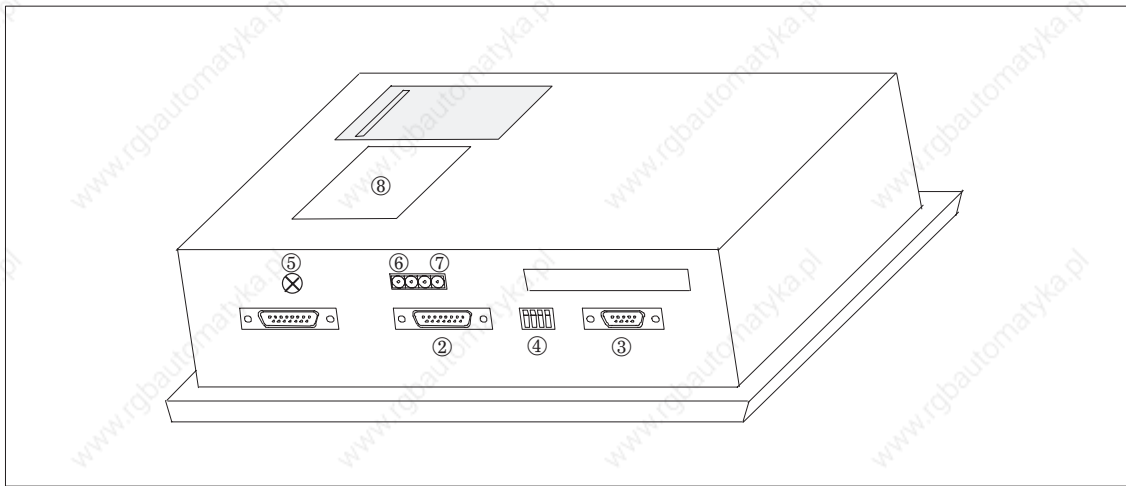

Figure 14-1 Arrangement of connections

No.	Name/Purpose	Description	
	Serial interfaces <sup>1)</sup> :	Level	Usage
①	• IF1A	RS232/TTY (active/passive)	PLC
②	• IF2	RS232/TTY (active/passive)	PC, PU, printer
③	• IF1B	RS422/RS485 (floating)	PLC
④	DIL switch <sup>2)</sup>	for configuring the IF1B interface.	
⑤	Grounding connection	—	
⑥	Power supply <sup>3)</sup>	Voltage supply (+ 24 V DC).	
⑦	Relay output <sup>3)</sup>	Relay contact for a buzzer or light, for example.	
⑧	DKM/CPI interface <sup>4)</sup> (covered)	For connecting a direct key module with 16 digital outputs or a control panel interface with max. 32 digital inputs/outputs.	
⑨	Battery compartment (covered)	—	
	PCMCIA Slot	For JEIDA/PCMCIA cards	
<sup>1)</sup> Connection plug pin assignment, see Appendix B. <sup>2)</sup> For details of permissible switch settings, see Section 12.2.3 <sup>3)</sup> For details of pin assignments, see Section 12.2.1 <sup>4)</sup> For details of DKM connector pin assignments, see Section 17.1.2 ; and details of CPI connector pin assignments, see Section 17.2.2.			

## 14.4 Communication options

Device	Connection	Interface
SIMATIC S5	– AS511 (TTY) – FAP (TTY/RS232) – PROFIBUS-DP	IF1A IF1A IF1B
SIMATIC S7/M7	– PPI – MPI – PROFIBUS-DP	IF1B IF1B IF1B
SIMATIC 500/505	– RS232 – RS422/RS485	IF1A IF1B
Other PLCs	– RS232/TTY – RS422/RS485	IF1A IF1B
PC/PU	– (TTY/RS232)	IF2
Printer	– TTY/RS232	IF2



## Unit Description TP27-10

### In this chapter

This chapter provides information on:

- dimensions
- operating and display elements
- connection elements and
- communication options

of Touch Panel TP27-10.

## 15.1 Dimensions

### Unit dimensions

The following figure indicates the dimensions of the TP27-10 with the housing of the direct key module/control panel which is available on option.

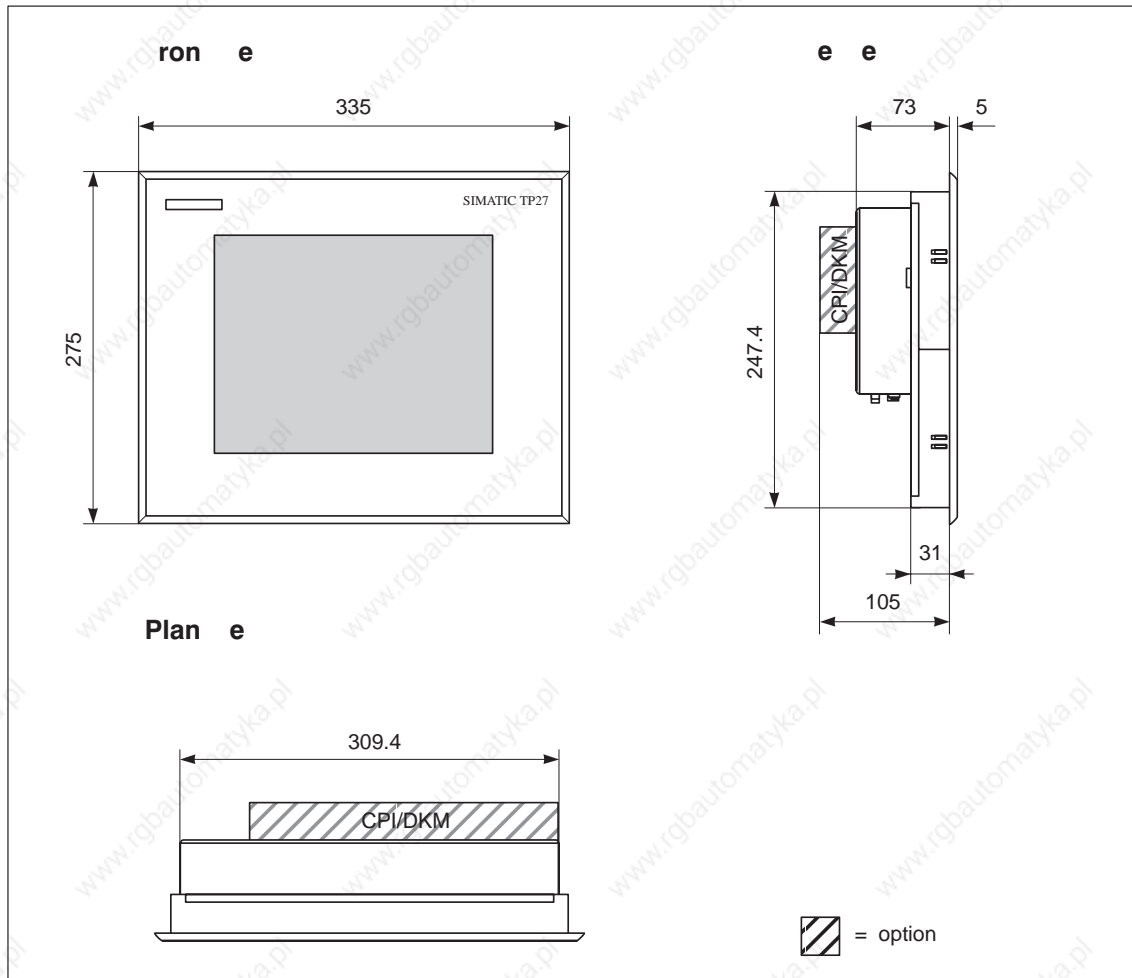

### Mounting cutout

The TP27-10 requires a mounting cutout (WxH) of  $310^{+1}$  mm x  $248^{+1}$  mm.

## 15.2 Operating elements

### Touch Screen

The TP27-10 touch screen is used to operate and monitor processes. The touch screen is operated by means of touching contact-sensitive buttons and input fields, located on the screen, which are defined in configurations for specific applications. An additional keyboard is not required.

## 15.3 Connection Elements

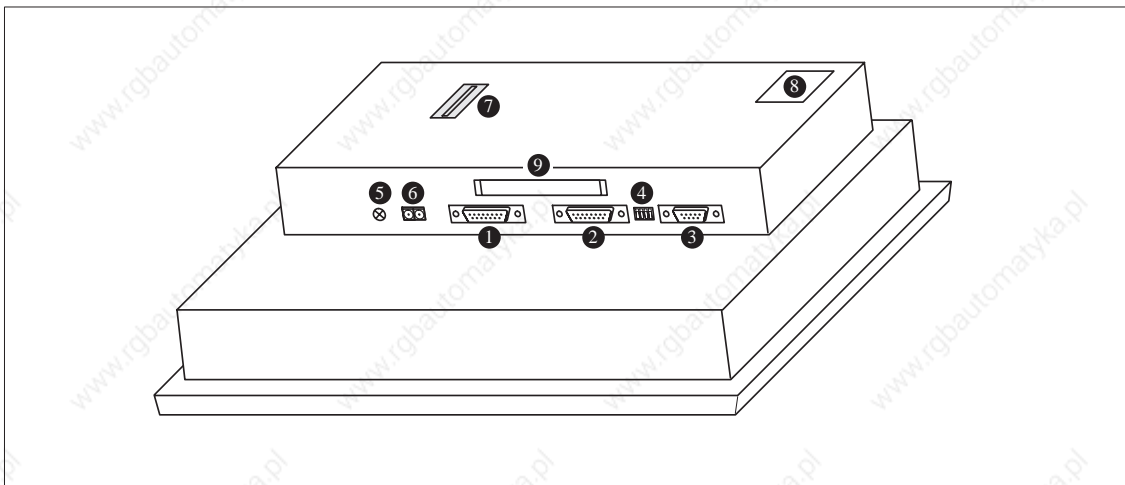

Figure 15-1 Arrangement of connections

No.	Name/Purpose	Description	
	Serial interfaces <sup>1)</sup> :	Level	Usage
①	• IF1A	RS232/TTY (active/passive)	PLC
②	• IF2	RS232/TTY (active/passive)	PC, PU, printer
③	• IF1B	RS422/RS485 (floating)	PLC
④	DIL switch <sup>2)</sup>	For configuring the IF1B interface.	
⑤	Grounding connection	—	
⑥	Power supply <sup>3)</sup>	Voltage supply (+ 24 V DC).	
⑦	DKM/CPI interface <sup>4)</sup> (covered)	For connecting a direct key module with 16 digital outputs or a control panel interface with max. 32 digital inputs/outputs.	
⑧	Battery compartment (covered)	—	
⑨	PCMCIA Slot A and Slot B	For JEIDA/PCMCIA cards (can only be used for Slot B).	
<p>1) For the connection plug pin assignment, see Appendix B.</p> <p>2) For details of permissible switch settings, see Section 12.2.3</p> <p>3) For details of pin assignments, see Section 12.2.1</p> <p>4) For details of DKM connector pin assignments, see Section 17.1.2; and details of CPI connector pin assignments, see Section 17.2.2</p>			

## 15.4 Communication options

Device	Connection	Interface
SIMATIC S5	– AS511 (TTY) – FAP (TTY/RS232) – PROFIBUS-DP	IF1A IF1A IF1B
SIMATIC S7/M7	– PPI – MPI – PROFIBUS-DP	IF1B IF1B IF1B
SIMATIC 500/505	– RS232 – RS422/RS485	IF1A IF1B
Other PLCs	– RS232/TTY – RS422/RS485	IF1A IF1B
PC/PU	– (TTY/RS232)	IF2
Printer	– TTY/RS232	IF2

# 16

## Unit Description TP37

### In this chapter

This chapter provides information on:

- dimensions
- operating and display elements
- connection elements and
- communication options

of Touch Panel TP37.

## 16.1 Dimensions

### Unit dimensions

The figure below indicates the dimensions of the TP37 with the housing of the direct key module/control panel which is available on option.

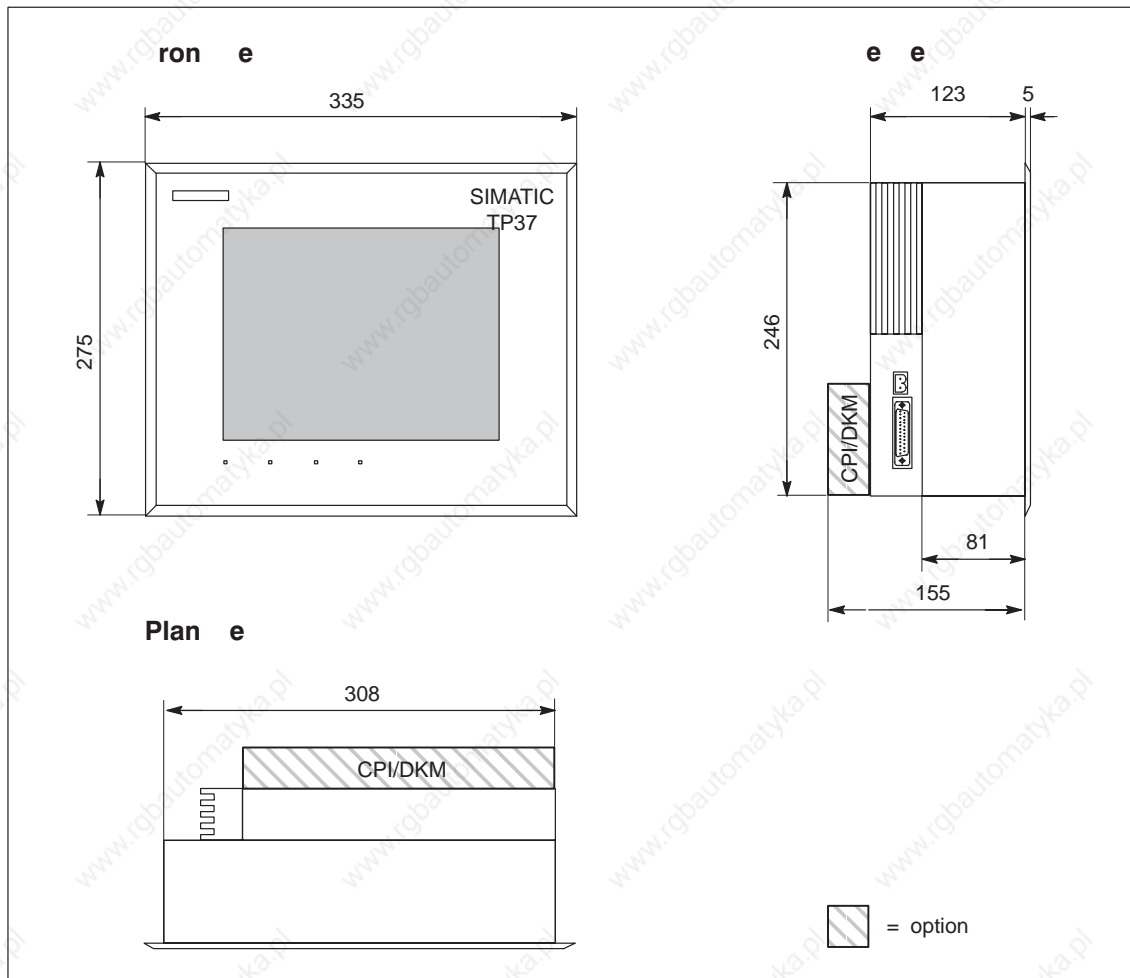

### Mounting cutout

The TP37 requires a mounting cutout (WxH) of  $310^{+1}$  mm x  $248^{+1}$  mm.

## 16.2 Operating and Display Elements

### Touch screen

The TP37 touch screen is used to operate and monitor processes. The touch screen is operated by means of touching contact-sensitive buttons and input fields, located on the screen, which are defined in configurations for specific applications. An additional keyboard is not required.

### LEDs

The LEDs located beneath the display indicate the following operating statuses of the TP37:

- **TEMP**  
The temperature inside the TP37 has exceeded the permissible limit value; the monitoring relay has tripped (see Section 12.2.1).
- **DISK**  
Write/read access to memory card.
- **HD BUSY**  
No function currently assigned.
- **POWER**  
The TP37 in operation.

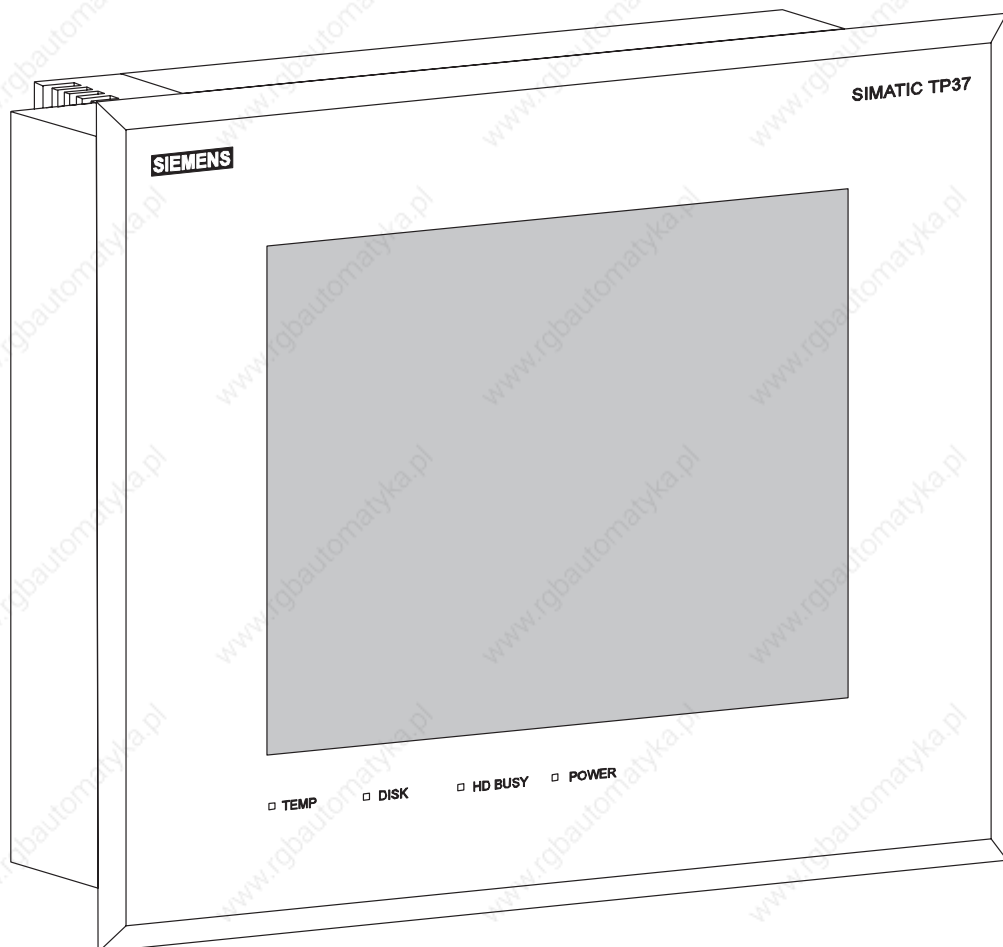

**Volume control**

On the underside of the unit, below the power supply/relay connection, is a potentiometer to adjust the volume of acoustic signals. The potentiometer is inside the device and can be adjusted by inserting a screwdriver through the ventilation slits.

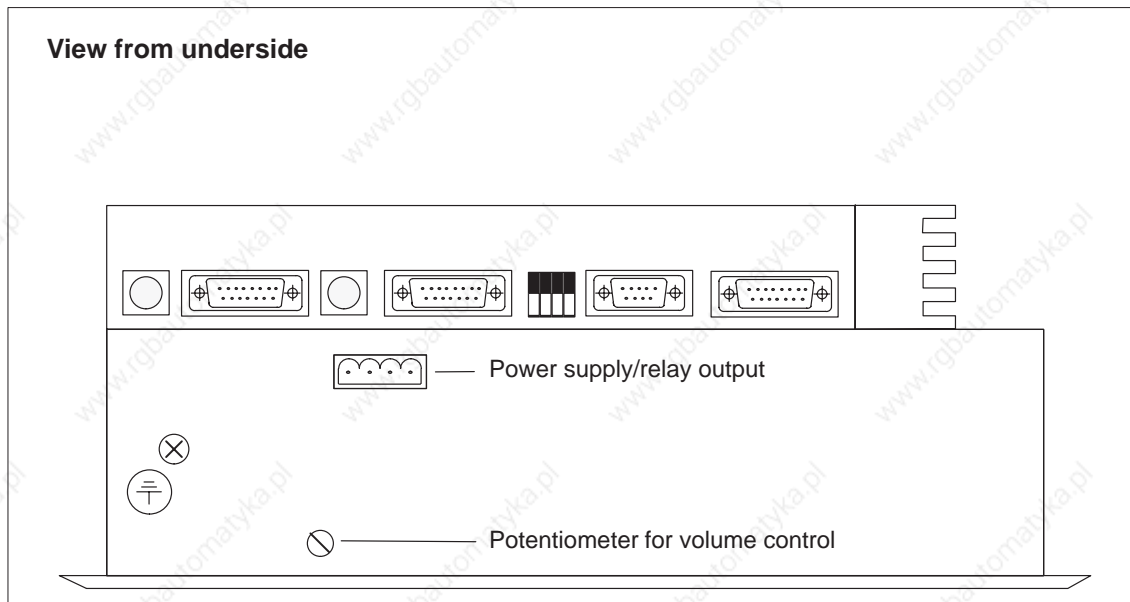

**Warning**

Use an insulated electrician's screwdriver to adjust the potentiometer. Insert the screwdriver only at the position indicated and use it only to adjust the potentiometer inside the device.

---

## 16.3 Connection Elements

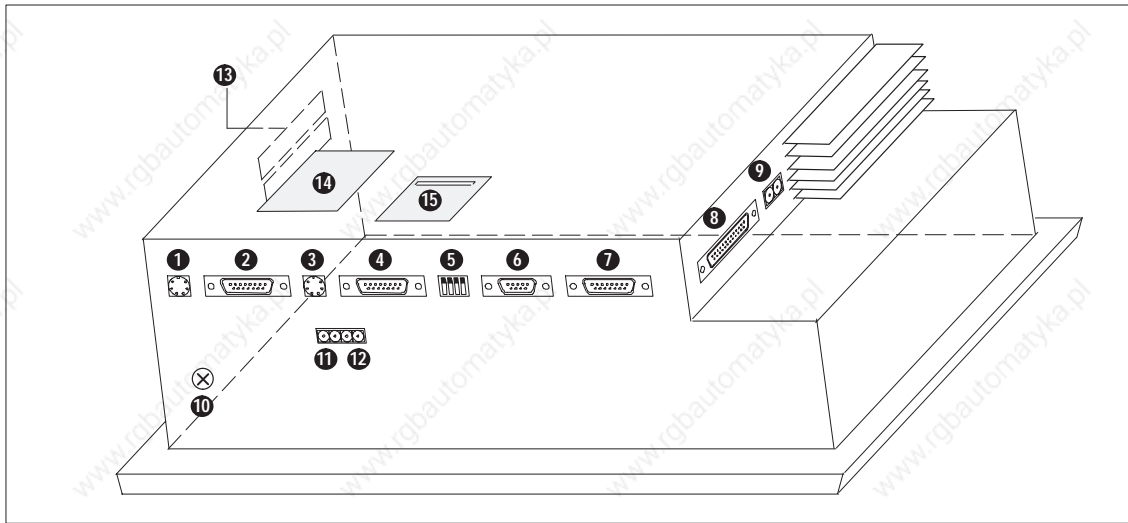

Figure 16-1 Arrangement of connections

No.	Name/Purpose	Description	
①	Currently unassigned	-	
③	Currently unassigned	-	
⑤	DIL switch <sup>1)</sup>	For configuring the IF1B interface.	
②	Serial interfaces <sup>2)</sup> : • IF1A • IF2 • IF1B • IF3	Level	Usage
④		RS232/TTY (active/passive)	PLC
⑥		RS232/TTY (active/passive)	PC, PU, printer
⑦		RS422/RS485 (floating)	PLC
		TTY (passive)/RS422/RS485	Not used at present
⑧	Parallel interface LPT <sup>2)</sup>	For connecting a parallel printer	
⑨	Relay output <sup>3)</sup>	Relay contact for temperature monitoring and driving for example, a light or an external fan. The relay is tripped when the outside temperature reaches 45 °C.	
⑩	Grounding connection	-	
⑪	Relay output <sup>3)</sup>	Relay contact for a horn or light, for example.	
⑫	Power supply <sup>3)</sup>	Voltage supply (+ 24 V DC).	
⑬	PCMCIA slot A and slot B	For JEIDA/PCMCIA cards (only slot B can be used, upper slot in Figure 16-1).	
⑭	DKM/CPI interface <sup>4)</sup> (covered)	For connecting a direct key module with 16 digital outputs or a control panel interface with max. 32 digital inputs/outputs.	
⑮	Battery compartment (covered)	-	
<p>1) For details of permissible switch settings, see Section 12.2.3</p> <p>2) For connector plug pin assignment, see Appendix B.</p> <p>3) For details of pin assignments, see Section 12.2.1</p> <p>4) For details of DKM connector pin assignments, see Section ; and details of CPI connector pin assignments, see Sections 17.1.2, 17.2.2</p>			

## 16.4 Communication options

Device	Connection	Interface
SIMATIC S5	– AS511 (TTY) – FAP (TTY/RS232) – PROFIBUS-DP	IF1A IF1A IF1B
SIMATIC S7/M7	– PPI – MPI – PROFIBUS-DP	IF1B IF1B IF1B
SIMATIC 500/505	– RS232 – RS422/RS485	IF1A IF1B
Other PLCs	– RS232/TTY – RS422/RS485	IF1A IF1B
PC/PU	– (TTY/RS232)	IF2
Printer	– TTY/RS232 – TTL	IF2 LPT

## Options

### Overview

This chapter contains descriptions of the following units which can be optionally connected:

- Direct Key Module (DKM)
- Control Panel Interface (CPI)

### 17.1 Direct Key Module

A Direct Key Module (DKM) is available as an option for connection to the Touch Panel. The following variants are available:

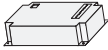
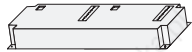
Operator panel	Direct key module with	
	8 outputs	16 outputs
TP27		–
TP37	–	

The variants vary according to the units. The DKM for the

- TP27-6 consists of a module board (DKM A) and a small housing,
- TP27-10 and TP37 consists of two module boards (DKM A + DKM B) and a large housing (see figure 17-4).

The housing is secured to the rear of the Touch Panel. It can be retrofitted at any time.

### Function of the direct key module

The Direct Key Module (DKM) must be implemented where fast keyboard operation is required without any communication-related delays. Example: Direct key control for jog operation.

Direct keys can be operated via the software using buttons and messages, if configured in ProTool.

The direct key module provides eight digital outputs per board.

### External power supply

The digital outputs are galvanically isolated from the Touch Panel by means of optocouplers. Consequently, the boards require a dedicated voltage supply.

## 17.1.1 Installing the Direct Key Module

A Touch Panel can accommodate either a direct key module or a control panel interface (see section 17.2). The procedure for installing a direct key module is as follows:

1. Place the front panel of the Touch Panel on a workbench.



### Caution

- Make sure that the Touch Panel is disconnected from the voltage supply.
- Always follow the ESD guidelines in the Appendix when working on open devices.

2. Release the two pop rivets ❶ and then the cover ❷ indicated in figure 17-1, in an example of the TP37, from the rear panel of the Touch Panel.

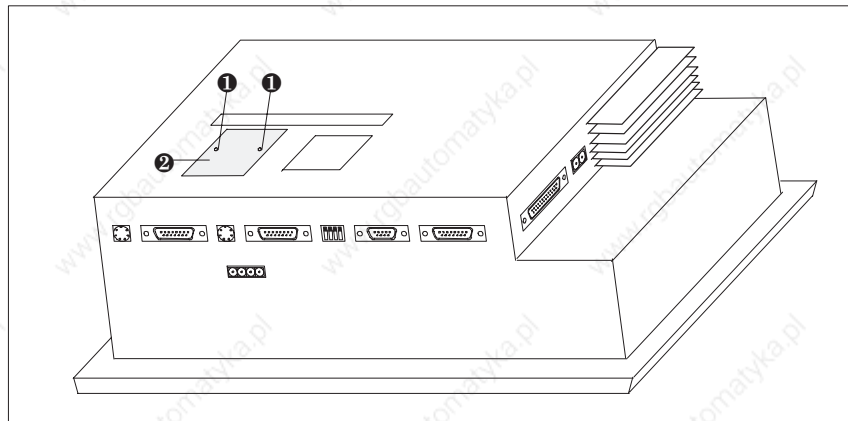

Figure 17-1 Removing the cover (example TP37)

3. Connect the plug of the DKM ribbon cable to the Touch Panel pin array so that the colored side of the ribbon cable faces in towards the inside of the unit (illustrated in an example of the TP37 in figure 17-2).

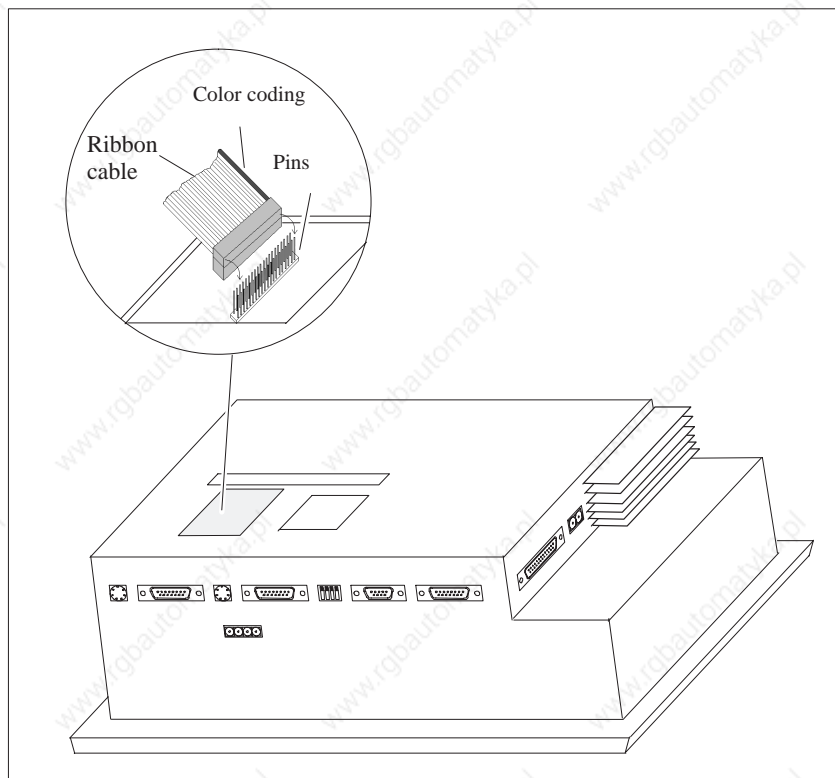

Figure 17-2 Connecting the direct key module (example: TP37)

4. Secure the direct key module to the Touch Panel using the four screws ③ enclosed (illustrated in an example of the TP37 in figure 17-3).

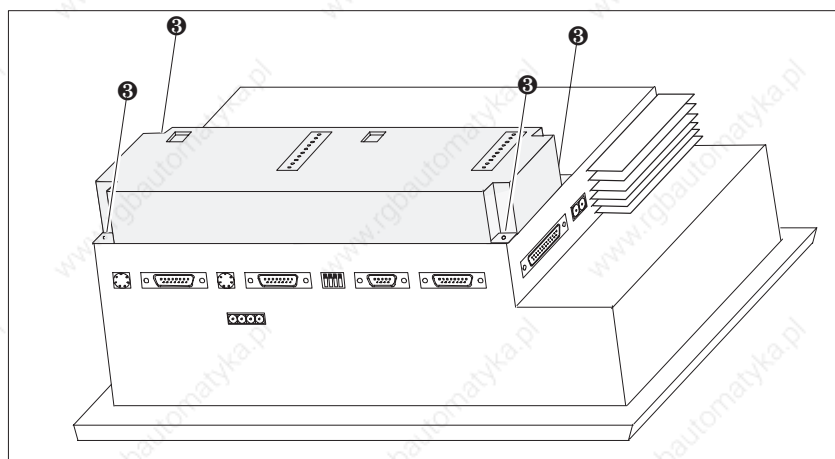

Figure 17-3 Securing the direct key module (example: TP37)

Removal is carried out in the reverse of the installation procedure.

## 17.1.2 Connectors and Adjusters

Each DKM board has

- a 10-pin array for connecting the outputs and external voltage supply, and
- a DIL switch for configuring the outputs so that they can be set by the software.

When installed, the pin array and DIL switch are on the rear side of the Touch Panel (illustrated in an example of the TP37 in figure 17-4).

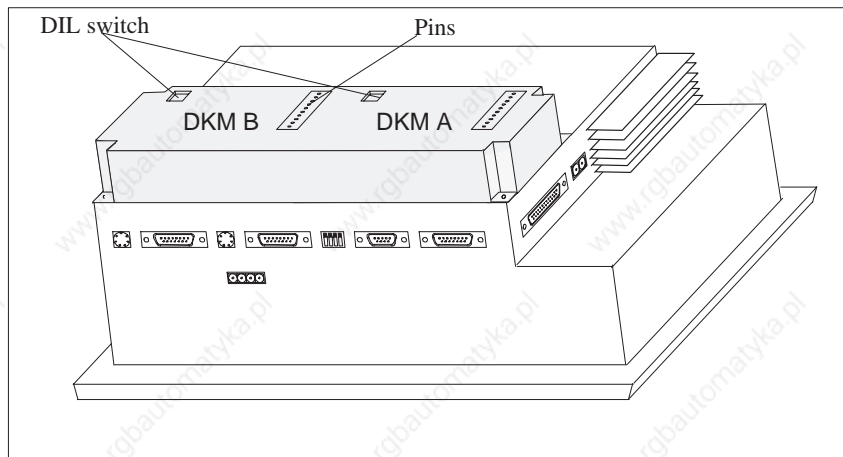
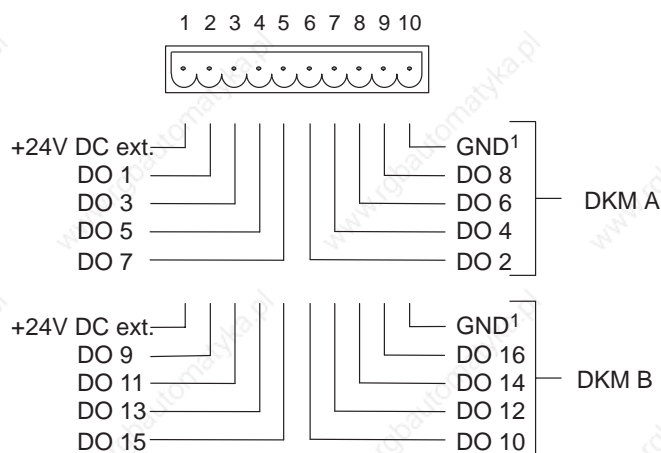

Figure 17-4 Location of the connection and adjustment elements (example TP37)

## Pin arrays

The pin arrays of the module boards DKM A and DKM B have the following pin assignment:



### 1) floating

The components to be triggered (e.g. relays, signaling indicators, etc.) are connected by means of the five-pin connectors supplied:

- Connect the wires (conductor cross-sections 0.5 ... 2.5 mm<sup>2</sup>)
- Plug the terminal blocks onto the pins of the DKM

## DIL switch



The DIL switches on the direct key modules DKMA and DKMB must be set as follows:



- S1 must always be ON;
- S2 selects the module board (DKM A = ON, DKM B = OFF);
- S3 and S4 must be ON to drive the outputs.

## 17.2 Control Panel Interface

A Control Panel Interface (CPI) is available as an option for Touch Panels connected to SIMATIC S7 PLCs. The following variants are available:

Operator panel	Control Panel Interface with		
	16 inputs/outputs	16 inputs/outputs	32 inputs/outputs
TP27		–	–
TP37	–		

The variants vary according to the units. The DKM for the

- TP27-6 consists of a module board (CPI) and a small housing,
- TP27-10 and TP37 consist of a module board (CPI) or two module boards (CPI1 + CPI2) and a large housing (see figure 17-8).

The housing is secured to the rear of the Touch Panel. It can be retrofitted at any time.

### Function of the control panel interface

The Control Panel Interface must be implemented where fast key operation is required without any communication-related delays (jog operation < 100 ms). It communicates via the PROFIBUS-DP bus and can only be used in conjunction with the SIMATIC S7 PLC.

Each module board provides 16 digital inputs/outputs. An external keypad with controls and light indicators can be connected for each module board. The assignment of the digital inputs/outputs to the control and light indicators of the external keypads is configured in the PLC (also refer to the *Communication User's Guide*).

### External power supply

The Control Panel Interface requires its own power supply. Note, however, that the digital inputs/outputs are not isolated from the Touch Panel.

## 17.2.1 Installing the Control Panel Interface

A Touch Panel can accommodate either a control panel interface or a direct key module (see section 17.1.1). Use the following procedure to install a control panel interface:



### Caution

- Make sure that the Touch Panel is disconnected from the voltage supply.
- Always follow the ESD guidelines in the Appendix when working on open devices.

1. Place the front panel of the Touch Panel on a workbench.
2. Release the two pop rivets ❶ and then the cover ❷ indicated in figure 17-5 in an example of the TP37, from the rear panel of the Touch Panel.

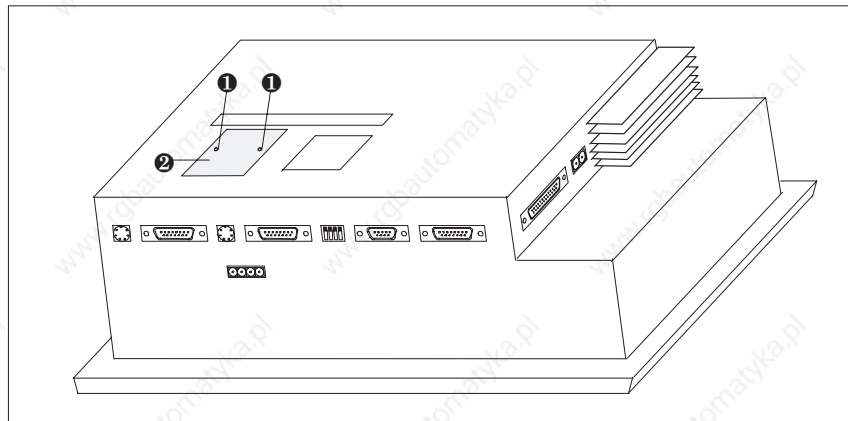

Figure 17-5 Removing the cover (example TP37)

3. Connect the plug of the CPI ribbon cable to the Touch Panel pin array so that the colored side of the ribbon cable faces in towards the inside of the unit (illustrated in an example of the TP37 in figure 17-6).

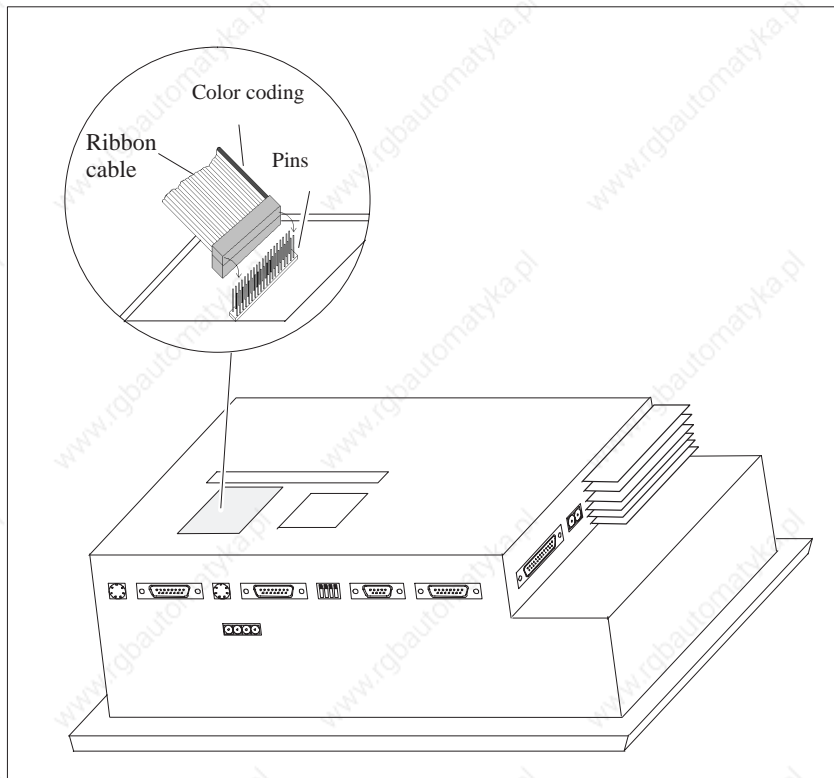

Figure 17-6 Connecting the control panel interface (example: TP37)

4. Secure the control panel interface to the Touch Panel with the four screws enclosed (3) (illustrated in an example of the TP37 in figure 17-7).

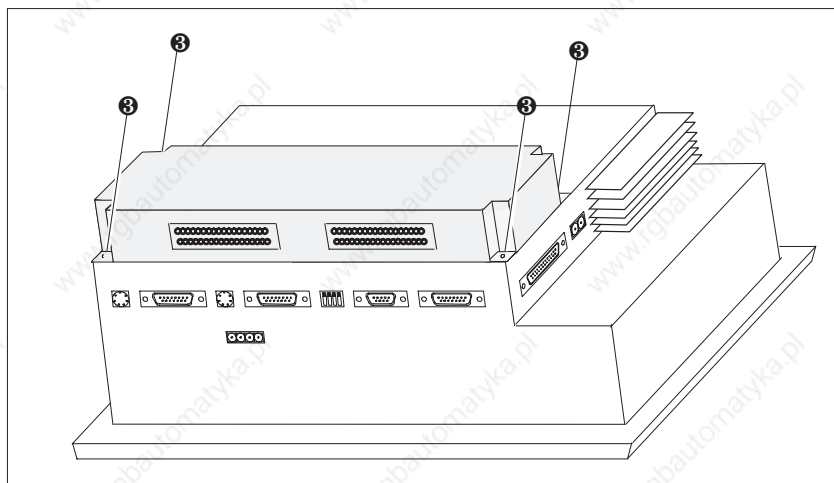

Figure 17-7 Securing the control panel interface (example: TP37)

Removal is carried out in the reverse of the installation procedure.

## 17.2.2 Connectors

Each of the two module boards has a 36-pin adapter for connecting the inputs/outputs and the external voltage supply.

When the module is installed, the connectors are located on the rear side of the Touch Panel (illustrated in an example of the TP37 in figure 17-8)

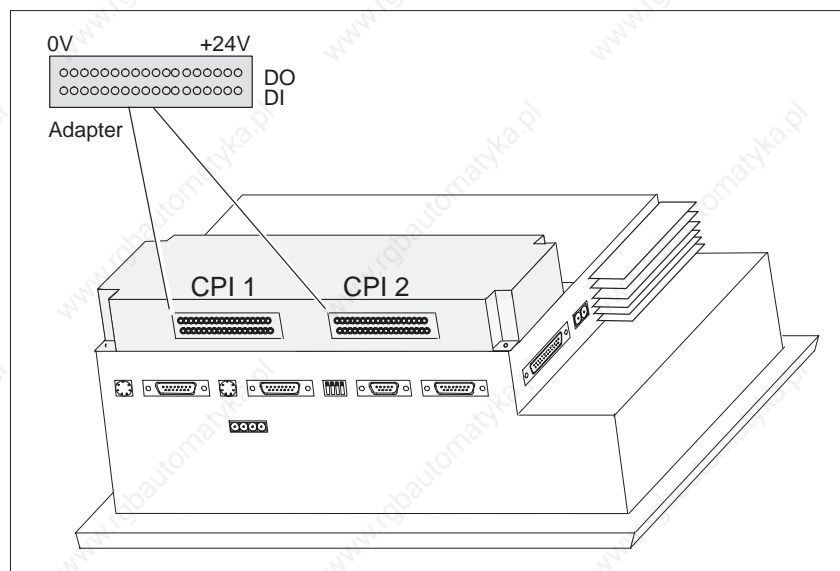
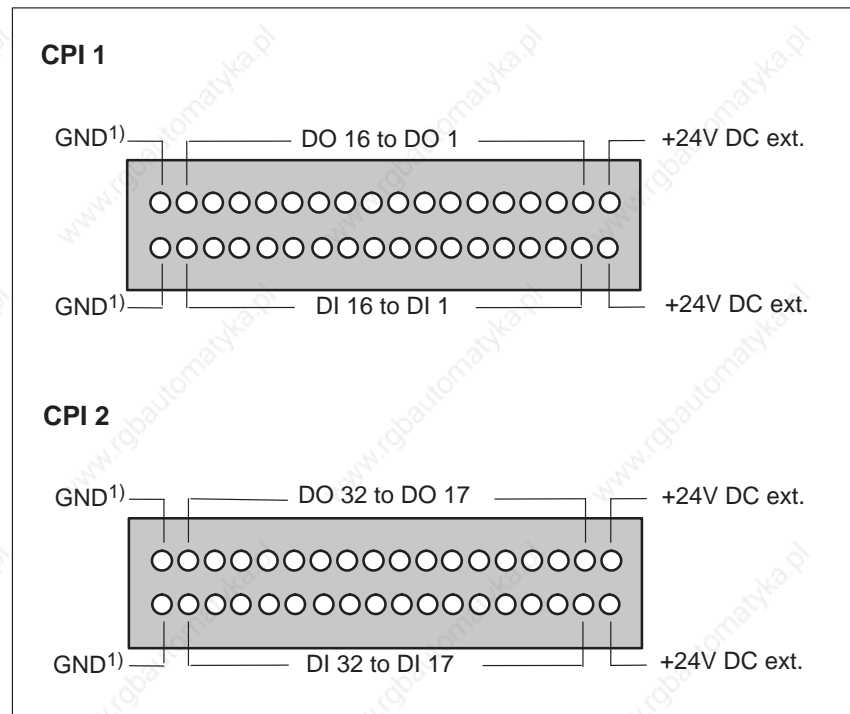

Figure 17-8 Location of the connection elements (example TP37)

**Connectors**

The connectors of module boards CPI 1 and CPI 2 have the following pin assignment when installed (see figure 17-8):



1) not isolated

The controls and light indicators to be used are connected by means of the nine-pin connectors supplied.

- Connect the wires (conductor cross-sections 0.5 ... 2.5 mm<sup>2</sup>)
- Plug in the terminal blocks on the adapters of the CPI module boards.

## Maintenance/Upkeep

- Scope** The Touch Panels TP27 and TP37 are designed for low maintenance operation. Maintenance of the TP is limited to
- regular cleaning of the screen
  - changing the backup battery and
  - replacing the LCD back-lighting (TP37 only).

### 18.1 Cleaning the Screen

- Preparation** Clean the Touch Panel screen at regular intervals using a damp cloth. Do not clean the TP while it is turned on. Either switch the unit off or deactivate the Touch Screen. The way to deactivate the Touch Screen is described in Section 11.3. This ensures that functions are not triggered by inadvertently coming into contact with the touch screen.

- Cleaning agents** Use only water or a screen cleaning foam to dampen the cloth. Do not spray cleaning agents directly onto the screen, but onto the cloth. Never use aggressive solvents or scouring powder.

- Protective foil** The protective foil for the TP prevents the screen being scratched or soiled. It is available as an option at your local Siemens branch.

## 18.2 Replacing the Backup Battery

### Function

The backup battery ensures that, in the event of a power failure

- the operating data (trend data, passwords, messages) in the SRAM of the Touch Panel is retained, and
- the hardware clock does not stop.

### Service life

Under normal operating conditions, the service life is approximately 4 years. A dead battery is indicated in routine operation by a system message on the Touch Panel. Replace the backup battery as quickly as possible after the message is received.

### Source of supply

The battery can be ordered via the Siemens spare parts service. It is shipped ready for installation with a lead and connector. See our catalog ST80.1 for the order number.

### Before changing the battery



Observe the following before changing the battery:

---

#### Caution

- Change the battery with the power supply switched on, in order to prevent loss of data; passwords, for example.
  - The battery must be changed by a properly qualified person.
  - Before replacing the battery, note the ESD guidelines in Appendix E of this manual.
-

**Action**

Step	Action
1	If a direct key module or control panel interface is connected to the TP37, remove it (see section 17.1 or 17.2) in order to gain access to the cover of the battery compartment.  Switch off the voltage supply before removing the DKM or CPI. After removing the direct key module or the control panel interface, switch on the voltage supply before removing the battery.
2	Remove the grey, plastic cover of the battery compartment at the rear of the Touch Panel.
3	Remove the battery lead connector from the two-pin plug connector on the TP.
4	Remove the dead battery from the holder and insert the new one. The snap-in plastic holder secures the battery in the battery compartment.
5	Insert the battery lead connector back into the plug connector. The connector is coded and thus protected against polarity reversal.
6	Stow the lead in the battery compartment and close the battery compartment.

**General notes**

Please observe the following safety notes to ensure correct handling and disposal of lithium batteries:

**Warning**

- If the lithium battery is not handled properly, there is risk of explosion.
- Batteries
  - should never be charged
  - should not be opened
  - should not be short-circuited
  - should be safeguarded against polarity reversal
  - should not be exposed to temperatures in excess of 100 °C
  - should be protected against direct sunlight.
- Do not allow condensation to form on batteries.
- Should shipping become necessary, ensure compliance with the Dangerous Chemicals Ordinance for the carrier concerned (coding obligation).
- Treat used lithium batteries as special waste. Pack them in separate leak-proof plastic bags to dispose of them.

## 18.3 Replacing the Back-Lighting (TP37 only)

### Note on TP27

The back-lighting of the TP27 cannot be replaced by the user. Please contact your Siemens representative if the back-lighting is defective.

### Service life

The brightness of the LCD back-lighting decreases during the course of time for technological reasons. The difference in brightness between a new fluorescent tube and an old one is clearly noticeable on the screen. Therefore, replace both tubes simultaneously if one fails. This saves having to open up the TP a second time when the second tube fails.

The way to increase the service life of the two fluorescent tubes by blanking the screen is described in Section 11.2.

### Before replacing

The unit must be opened up in order to replace the back-lighting. Observe the following notes on safety with regard to opening the TP:



---

#### Warning

- Repairs to the TP must be performed by suitably qualified, authorized technical personnel.
  - The user may be exposed to extreme risk as a result of unauthorized opening of the TP and inexperienced repairs.
  - The display back-lighting operates at voltages > 1000 V. Ensure that the TP37 is disconnected from the power supply before the TP is opened.
  - Crystal liquid may leak from a damaged display.  
Do not allow liquid to come in contact with the skin; do not inhale vapors. If crystal liquid does come into contact with the skin, wash the affected area skin immediately with alcohol.  
Consult a doctor without delay.
  - Before working on an open unit, observe the ESD guidelines in the Appendix E of this manual.
-

## Procedure

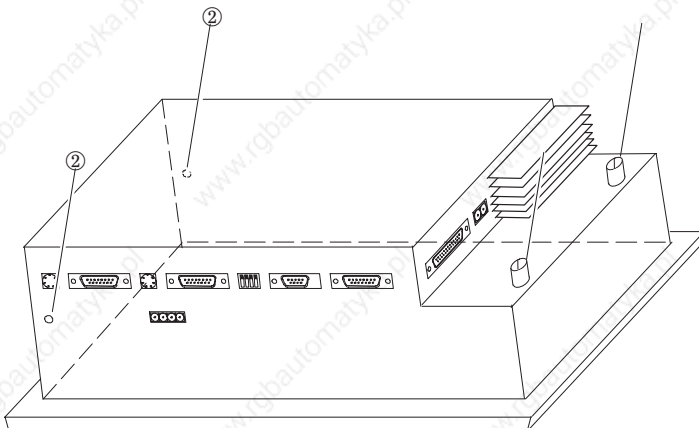
Step	Action
1	Slacken the two knurled screws ② at the rear of the TP and loosen the two screws ② at the top and underside. 
2	Carefully tilt the hinged rear panel backwards until the plug connections for the ribbon cable and 8-pin socket housing can be removed. Then tilt the rear panel backwards as far as the stop.
3	Undo two screws per fluorescent tube ③ (figure 18-1) and remove the covers ④.
4	Remove the two connectors ⑤.
5	Replace the fluorescent tubes.
6	Reassemble in the reverse sequence of the disassembly procedure.

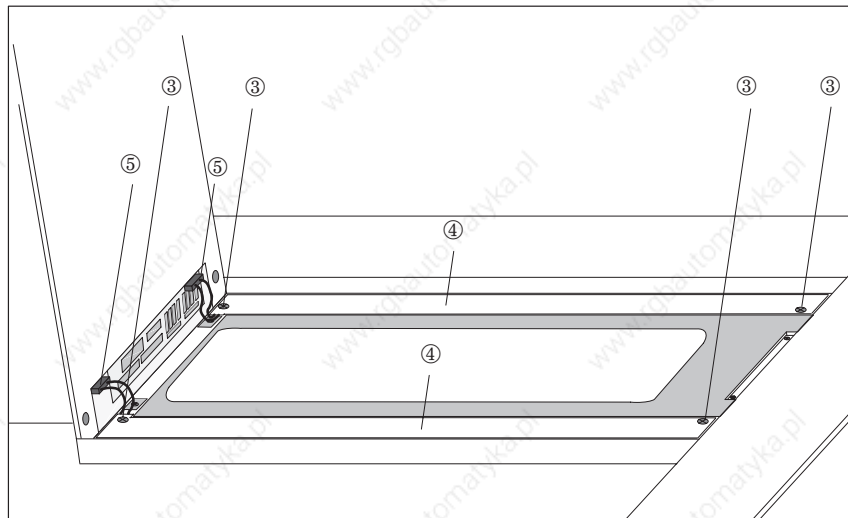

Figure 18-1 Replacing the back-lighting



## **APPENDICES**

# **Part V**

- A Technical Data**
- B Interface Assignments**
- C System Messages**
- D SIMATIC HMI Documentation**
- E ESD Guidelines**



# A

## Technical Data

Housing	TP27-6	TP27-10	TP37
External dimensions W x H x T (mm) without option	212 x 156 x 69	335 x 275 x 78	335 x 275 x 128
Mounting cutout W x H (mm)	203 <sup>+1</sup> x 147 <sup>+1</sup>	310 <sup>+1</sup> x 248 <sup>+1</sup>	
Mounting depth (mm) without option	65	73	123
Degree of protection <ul style="list-style-type: none"> <li>• Front panel</li> <li>• Rear panel</li> </ul>	IP65 IP20		
Weight approx. (kg) without option	1.5	5	7

Processor	TP27-6	TP27-10	TP37
Type	80486		Pentium
Clock frequency (MHz)	33		100

Memory	TP27-6	TP27-10	TP37
Flash (MB)	1		2
DRAM (MB)	2		8
SRAM, battery-backed (KB)	128		128
Memory card <ul style="list-style-type: none"> <li>• Slot A</li> <li>• Slot B</li> </ul>	- For memory card $\pm$ MB		Not used For memory card $\pm$ MB

## Technical Data

Display	TP27-6	TP27-10	TP37
Type	STN LCD		TFT LCD
Resolution (horizontal x vertical)	320 x 240	640 x 480	
Active screen area (mm x mm)	106 x 79	215 x 165	211 x 158
Back-lighting	1 CCFL tube	2 CCFL tubes	2 CCFL tubes
Service life <sup>1)</sup> approx. (h) with			
– Monochrome display	50,000	–	–
– color display	50,000	50,000	25,000
<sup>1)</sup> The back-lighting tube for the display is a wear part and is therefore not covered by the warranty. TP37: In unfavorable operating conditions we recommend replacing the tube after the period has elapsed. The tube is available as a spare part.			

Power supply	TP27-6	TP27-10	TP37
Rated voltage (VDC)	+24		
Permissible range (VDC)	+18 to +30		
Maximum permissible transients	35 V (500 msec)		
Time between two transients	50 sec minimum		
Typical power consumption at 24 V	Approx. 0.4 A	Approx. 0.7 A	Approx. 1.3 A
Switch-on current I <sup>2</sup> t	0.45 A <sup>2</sup> s		0.55 A <sup>2</sup> s
Fuse, internal	Electronic fuse		

Backup battery	TP27-6	TP27-10	TP37
Type	lithium battery		
Voltage/capacity <sup>2)</sup>	3.6 V/approx. 1.5 Ah		
Service life	> 4 years		
<sup>2)</sup> Technical details subject to change without notice.			

Relay contact with current supply (message relay)	TP27-6	TP27-10	TP37
Switching power	24 V DC, 0.4 A (no inductive load)	–	24 V DC, 0.4 A (no inductive load)



Relay contact for temperature monitoring	TP27-6	TP27-10	TP37
Switching power	–	–	24 V DC, 0.4 A (No inductive load)

Ambient conditions	TP27-6	TP27-10	TP37
Location <ul style="list-style-type: none"> <li>Maximum permissible angle of inclination</li> </ul>	vertical ± 35°		
Ambient temperature <ul style="list-style-type: none"> <li>Operation in vertical position</li> <li>Operation at 35° angle of inclination from the perpendicular</li> <li>Shipping, storage</li> </ul>	0 ... 50° C  0 ... 35° C  -20 to 60° C	5 to 45° C  4 to 45° C  -20 to 60° C	4 to 45° C  -20 to 60° C
Relative humidity <ul style="list-style-type: none"> <li>Operation</li> <li>Shipping, storage</li> </ul>	≤ 95%, no condensation ≤ 95%		
Shock loading <ul style="list-style-type: none"> <li>Operation</li> <li>Shipping, storage</li> </ul>	15 g/11 msec 25 g/6 msec		
Vibration <ul style="list-style-type: none"> <li>Operation</li> <li>Shipping, storage</li> </ul>	0.075 mm (10 Hz to 58 Hz) 1 g (58 Hz to 500 Hz) 3.5 mm (5 Hz to 10 Hz) 1 g (10 Hz to 500 Hz)	0.075 mm (10 Hz to 58 Hz) 1 g (58 Hz to 500 Hz) 3.5 mm (5 Hz to 8.5 Hz) 1 g (8.5 Hz to 500 Hz)	
Barometric pressure <ul style="list-style-type: none"> <li>Operation</li> <li>Shipping, storage</li> </ul>	706 to 1030 hPa 581 to 1030 hPa		

Compliance of the named products with the regulations of Directive 89/336 EEC is verified by conformance with the following standards:

Noise immunity EN 50082-1	TP27-6	TP27-10	TP37
Static discharge (contact discharge)	EN 61000-4-2 Class 3		
RF irradiation	EN 61000-4-3 Class 3		
Pulse modulation	ENV 50204 (900 MHz $\pm$ 5 MHz)		
RF conduction	ENV 50141 Class 3		
Burst interference	ENV 61000-4-4 Class 3		

Radio interference	TP27-6	TP27-10	TP37
RFI suppression	EN 55022 Class A		

Certifications	TP27-6	TP27-10	TP37
UL certification	UL Recognition Mark Underwriters Laboratories (UL) in compliance with Standard UL 508, File E 120869		
CSA certification	CSA Certification Mark Canadian Standard Association (CSA) in compliance with Standard C 22.2 No. 142, File LR 89077-19		
FM certification	FM Certification Complying with Factory Mutual Approval Standard Class Number 3611 Hazardous (classified) Locations Class I, Division 2, Group A, B, C, D		
	<div style="display: flex; align-items: flex-start;"> <div style="margin-right: 10px;">  </div> <div> <p><b>Warning</b></p> <p>Personal injury and material damage may occur. Personal injury and material damage may occur in hazardous areas if plug connections are disconnected during the routine operation of a TP.</p> <p>In hazardous areas, always de-energize the TP before unplugging connectors.</p> </div> </div> <hr/> <div style="display: flex; align-items: flex-start;"> <div style="margin-right: 10px;">  </div> <div> <p><b>Warning</b></p> <p><b>WARNING – DO NOT DISCONNECT WHILE CIRCUIT IS LIVE UNLESS LOCATION IS KNOWN TO BE NONHAZARDOUS.</b></p> </div> </div>		

## A.1 Direct Key Module and Control Panel Interface

Direct key module (DKM)	
<b>Voltage supply for outputs, load voltage supply and internal logic circuitry</b>	
Voltage supply <ul style="list-style-type: none"> <li>rated value</li> <li>permissible range</li> <li>value at <math>t &lt; 0.5</math> sec</li> </ul>	+ 24 V DC +18.0 to +30.0 V 35 V
Power consumption of logic circuitry	50 mA
Short-circuit protection upon polarity reversal of load voltage	✓
<b>Outputs<sup>3)</sup></b>	
No. of outputs	8 per module
Output voltage <ul style="list-style-type: none"> <li>with signal "0"</li> <li>with signal "1"</li> </ul>	Max. 2 V (idling) Min. (voltage supply -3 V)
Output current <ul style="list-style-type: none"> <li>with signal "0"</li> <li>with signal "1"</li> </ul>	Max. 1 mA Max. 300 mA per output
Switch rate at <ul style="list-style-type: none"> <li>resistive load</li> <li>inductive load</li> <li>lamp load</li> </ul>	Max. 100 Hz Max. 0.5 Hz Max. 8 Hz
Short-circuit current	Max. 500 mA per output
<b>Note:</b> With inductive loads, an external free-wheeling diode must be used directly on the load.	

<sup>3)</sup> Outputs are isolated by means of optocouplers.

<b>Control Panel Interface</b>	
<b>Voltage supply for outputs, load voltage supply and internal logic circuitry</b>	
Voltage supply <ul style="list-style-type: none"> <li>rated value</li> <li>permissible range</li> <li>value at <math>t &lt; 0.5</math> sec</li> </ul>	OP37 24 V DC +18.0 to +30.0 V 35 V
Power consumption of logic circuitry	40 mA
Short-circuit protection upon polarity reversal of load voltage	✓
Connection of	Lamps (inductive load not permitted)
<b>Outputs</b>	
No. of outputs <ul style="list-style-type: none"> <li>in groups of</li> <li>output DO1 to DO4</li> <li>output DO5 to DO8</li> <li>output DO9 to DO12</li> <li>output DO13 to DO16</li> </ul>	16 4 Group 1 Group 2 Group 3 Group 4
Optical isolation	–
Output voltage <ul style="list-style-type: none"> <li>with signal “0”</li> <li>with signal “1”</li> </ul>	Max. 2 V (idling) Min. (voltage supply –3 V)
Output current <ul style="list-style-type: none"> <li>with signal “0”</li> <li>with signal “1”</li> </ul>	Max. 1 mA Max. 500 mA per group 1 output of 200 mA, the remainder 100 mA
Switch rate at <ul style="list-style-type: none"> <li>resistive load</li> <li>lamp load</li> </ul>	Max. 100 Hz Max. 8 Hz
Load current per group <ul style="list-style-type: none"> <li>aggregate current</li> <li>on short-circuit</li> </ul>	500 mA Complete group deenergized
Cable length	Max. 1 m
<b>Voltage supply for inputs</b>	
Voltage supply <ul style="list-style-type: none"> <li>rated value</li> <li>permissible range</li> <li>value at <math>t &lt; 0.5</math> sec</li> </ul>	+ 24 V DC +18.0 to +30.0 V 35 V
Connection of	Pushbuttons, switches (inductive load not permitted)

Control Panel Interface	
<b>Inputs</b>	
No. of inputs	16
Optical isolation from internal logic circuitry	–
Input voltage <ul style="list-style-type: none"> <li>• rated value</li> <li>• with signal “0”</li> <li>• with signal “1”</li> </ul>	24 V DC 0 to 5 V 15 to 30 V
Input current with signal “1”	Typically 5 mA at 24 V
Input delay	0.3 msec
Connection of mechanical switches	Possible
Bounce time	$\leq \times 10$ msec
Cable length of sensors, unshielded	1 m

## A.2 Chemical Resistance of the Touch Panel

### Chemical resistance of TP27-6

The surface of the TP27-6 complies to DIN 42 115 Teil 2 and shows no visible signs of change when exposed to the chemicals listed in Table A-1 for a period of over 24 hours.

Table A-1 Resistof the surface of the TP27 6''

Ethanol	Acetaldehyd	Fluorocarbons
Cyclohexanol	Aliphatics	Perchlorethylene
Glycol	Benzine	1.1.1 Trichlorethylene
Isopropanol	Toluol	Trichlorethylene
Glycerin	Xylene	Ethylacetate
Methanol	Benzole	Diethylether
Acetone	Formic acid < 50%	Chlomatron < 20%
Methyl ethyl Ketone	ethanoic acis < 95%	Hydrogen peroxide < 25%
Dioxan	Phosphoric acid < 30%	Potash soap
Dimethylformamide	Hydrochloric acid < 10%	Cleaning solution (Tenside)
Benzyl alcohol	Nitric acid < 10%	Softener
Ammoniac < 2%	drilling emulsion	
Sodium hydroxide < 2%	Diesel oil	
Alcali carbonate	Varnish	
Bichromate	Paraffin oil	
Potassium ferricyanide	Ricinusöl	
	Silicon oil	
	Terpentin oil substitute	



### Caution

- The surface of the TP27-6 is not resistant to the following chemicals:

Concentrated mineral acids	Methylene chloride
Concentrated alcaline solutions	
High pressure steam exceeding 100°C	

**Chemical Resistance of the TP37 and TP27-10**

The surfaces of the TP37 and TP27-10 complies to DIN 42 115 Teil 2 and shows no visible signs of change when exposed to the chemicals listed in Table A-2 for a period exceeding 24 hours.

Table A-2 Resistance of the surfaces of the TP37 and TP27-10

Acetone	Hexane	Toluol	< 40%
Butyl cellosolve	Isopropyl alcohol	Xylene	
Cyclohexanol	Methyl ethyl ketone	NaOH	
Ethyl acetate	Methylene chloride		
Mineral spirits			
Terpentine			
Vinegar			
Glass cleaner on ammoniac basis			
Household cleaners			



# B

## Interface Assignments

### IF1A and IF2

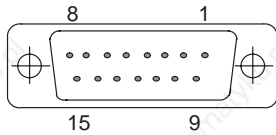

Pin assignment of the 15-pin Sub-D socket:

Pin	General	RS232	TTY
1	Housing		
2			RxD-
3		RxD	
4		TxD	
5		CTS	
6			TxD+
7			TxD-
8	Housing		
9			RxD+
10		RTS	
11			+20 mA <sup>1)</sup>
12	GND		
13			+20 mA <sup>1)</sup>
14	+5 V		
15	GND		

<sup>1)</sup> Not IF2

**IF1B**

Pin assignment of the 9-pin Sub-D socket  
(Configuration via DIL switch, see Chapter 12.2.3):

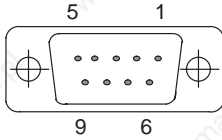

Pin	General	PROFIBUS-DP MPI	RS422	RS485
1				
2				
3		Data B	TxD (B)	Data B
4			RxD (B)	
5	GND (floating )			
6	+5 V (floating )			
7				
8	Housing	Data A	TxD (A)	Data A
9			RxD (A)	

**IF3 (TP37 only)**

Pin assignment of the 15-pin Sub-D socket:

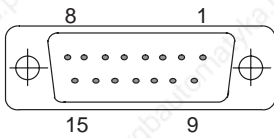

Pin	General	TTY	RS42	RS485
1	Housing			
2		RxD-		
3			RxD (B)	
4			TxD (B)	Data B
5			RxD (A)	
6		TxD+		
7		TxD-		
8	Housing			
9		RxD+		
10			TxD (A)	Data A
11	+24 V			
12	GND (5 V)			
13				
14	+5 V			
15	GND (24 V)			

**LPT (TP37 only)**

Pin assignment of the 25-pin Sub-D socket:

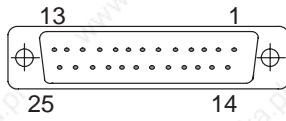

Pin	TTL (Centronics)
1	- Strobe
2	+ Data Bit 0
3	+ Data Bit 1
4	+ Data Bit 2
5	+ Data Bit 3
6	+ Data Bit 4
7	+ Data Bit 5
8	+ Data Bit 6
9	+ Data Bit 7
10	- Acknowledge
11	+ Busy
12	+ Paper End
13	+ Select
14	- Auto Feed
15	- Error
16	- Init Printer
17	- Select Input
18...25	Ground



# C

## System Messages

### Message number

OP system messages can be subdivided into various categories.

The information as to which category a system message belongs to is contained in the message number as indicated below.

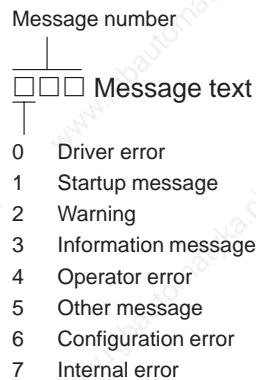

The message category enables you to identify the general area in which the cause of the fault is to be found.

Below you will find a selection of system messages listed together with details of under what circumstances they occur and, where applicable, how the cause of the fault can be eliminated.

Self-explanatory system messages are not included.

---

### Note

System messages are displayed in the language selected in the configuration. If the OP does not have access to any configuration data, the messages are displayed in English.

---

## System Messages

---

Message	Cause	Remedy
Please wait	Mode change in progress or recipe function started.	
Ready for transfer	Waiting for data from PU/PC	
Data transfer	Data transfer between PU/PC and OP in progress	
Firmware not compatible	The firmware can not be used for the current configuration	
EPROM memory failure	Memory module defective or internal hardware fault	Send unit for repair quoting details of error message
RAM memory failure		
Flash memory failure	Memory module defective or transmission error	Retransfer configuration or send OP for repair

Message	Cause	Remedy:
026...029	Storage medium not ready, contains errors or status undefinable.	Reset hardware, remove then refit Flash memory module or carry out hardware test.
030	Storage medium not initialized.	Switch to download mode.
032	Error accessing module, Flash may not be supported or initialized by incorrect OP.	Check whether module is properly inserted and compatible. If restoring: repeat backup with correct OP.
033	Internal Flash memory initialized; configuration data deleted, some recipe data preserved.	Retransfer configuration.
034	Inserted module initialized, all stored data deleted.	Retransfer configuration.
035	Size of selected recipe memory has been reduced.	The reduced-size recipe memory can not be used and all data records must be deleted. The recipe memory is only initialized when requested.
040	Driver error If FAP is set, the character delay time setting may be too short.	Check physical connection with PLC. Modify character delay time.
041	Fault in connection with PLC. Possible causes: – Fault on the transmission link, e.g. connecting cable defective – Incorrect interface parameters set on OP or on communication peer.	
043	Data transfer error. A variable indicating the cause of the fault is transferred with this message. <b>Variable:</b> 0 Timeout error 1 Framing error (receiving) 2 Overrun error 3 Parity error 4 No connection established 5 Checksum error (receiving) 6 Unexpected characters received 7...11 Internal error 12 Receive data block too large 13 Memory area not available on PLC	Repeat the data transfer. Before doing so, check the physical connection/configured interface parameters if necessary.
044	Fault in connection with PLC. Possible causes: – Fault on the transmission link, e.g. connecting cable defective – Incorrect interface parameters set on OP or on communication peer.	
114	PLC has been restarted.	
115	Establishment of logical link with PLC in progress.	
117	Connection with PLC is OK again following a fault.	
119	Automatic restart.	
136	PLC not responding.	Check program sequence on PLC. Check physical connection.
138	Data block not available on PLC	Set up relevant memory area.

Message	Cause	Remedy:
200	Battery power no longer sufficient for internal data buffer on OP.  Battery on memory is discharged, data may no longer be readable.	Replace battery.  <b>Note:</b> Replace the battery while the unit is switched on in order to prevent loss of data.
210	<i>Internal error</i> OP co-ordination area not receivable during startup.	Press restart button.
212	<i>Internal error</i> Bit for changing operating mode has been inverted erroneously.	Restart OP.
213	Offline mode not possible at present.	Try change of operating mode again later.
214	The job number sent by the PLC or configured in a function field is too large.	Check PLC program and configured screen.
217, 218	Overlapping specified/actual values.	Check configuration of actual/specified values in the process link.
230	The minimum value is greater than the maximum value for variable limits.	Correct the limit settings.
231	The minimum value is equal to the maximum value for variable scales.	Correct the scale on the OP.
250	You can not switch to the desired operating mode.	Check parameters of PLC job.
251	Error transferring data record to PLC.	Check recipe configuration.
252	Function can not be executed as a function of the same group has not yet been completed (e.g.: setpoint entry is active, password list can not be opened).	Wait until preceding function has been completed (or terminate function) and then invoke desired function again.
253	Access to data medium is not possible.	1. Floppy drive not present, 2. Floppy is read only, 3. Disk is not formatted.
254	The disk must be formatted before a data record can be saved for the first time.	First format the disk.
255	Not enough space on disk for this data record.	Delete data records that are no longer required.
256	Not enough system memory available to execute the desired function.	Try activating function again. Check configuration. 1. Move function to a different screen 2. Simplify screen structure 3. Do not use trends on screen in conjunction with this function
257	Data record has been stored with a different version stamp than defined in the current configuration.	If the data records are to continue to be used, the old version number must be entered in the recipe configuration.  <b>Caution:</b> The structure of the recipe determines the assignment of data to a data record.
258	A parameter record has been selected as a recipe. Parameter records can not be edited directly.	Only individual data records of a parameter record can be edited.

Message	Cause	Remedy:
259	Transfer of a data record to the PLC is taking too long. <b>Example:</b> PLC is not acknowledging data record or very large data records are being transferred.	Check PLC program. In the case of large data records no modifications are necessary as the function is being processed correctly.
260	Operating mode of PLC does not match the configuration.	Change operating mode of PLC.
261	The data in this data record is no longer consistent and it can therefore no longer be used.	Edit data record and check that all entries are correct.
262	Password or query window already in use by another function.	Complete first function then execute desired function again.
263	Specified remaining buffer space for messages has been reached!	Configure smaller remaining buffer, delete event/alarm message buffers.
264	Message buffer overflow.	The overflow messages are printed out if so specified in the configuration.
265	The number of passwords issued has already reached 50. You can not enter any more passwords.	If you wish to issue additional passwords, you must first delete some of the existing ones.
266	The field configured in the PLC job does not exist.	Change the parameters of the PLC job and retransfer the configuration.
303	Fault in connection with PLC. <b>S5:</b> this error may occur when transferring large data records. In such cases the watchdog is activated.	Check PLC status. <b>S5:</b> set value in data word 98 to at least 2000.
305	Data block number missing.	Set up data block or change configuration.
306	Incorrect CPU specified under "PLC -> Parameters".	Change configuration and retransfer.
307 ... 311	Variable not present on PLC	Check configuration of process link.
316	Active password level insufficient for menu item	Enter password with higher password level.
339	Startup completed.	Communication with PLC has been resumed.
340	Status processing in progress on PU/PC. The OP can not be used while this is going on.	
341	<i>Internal error</i> With non-Siemens connections: data block error	
342	Network node has illegal address.	Max. addresses: S7-MPI: 32 PROFIBUS-DP: 128
343	You are attempting to edit a variable of a type that can not be edited in a recipe: currently applies to ARRAY variables only.	
350	PLC is performing initialization. You can not enter any setpoints during initialization. Scrolling of screens is possible.	This operating mode may be set by the PLC programmer.
351	PLC has completed initialization. You can resume entering setpoints once this message has appeared.	

## System Messages

Message	Cause	Remedy:
352	You are attempting to select a screen that does not exist or has been disabled by the function Hide.	
353	The minimum value is greater than the maximum value for variable scales.	Minimum and maximum values are being confused by OP. To prevent this, enter correct minimum and maximum values.
354	You are attempting to enter a value in an input field when the current password level is insufficient for input.	Log on with a higher password level.
355	Entry of this variable has not been configured for the current PLC mode.	
356	A print function has been initiated on the OP. When attempting to print it has been ascertained that the printer is offline.	Switch the printer online. Check the connection between the OP and the printer. Has the printer been connected to the correct interface?
357	You are attempting to enter a setpoint that contains an illegal character.	Enter the value correctly.
358	The OP is currently executing a function which does not permit use of the OP while it is in progress.	Wait until the function has been completed. This message may appear in the case of recipe functions, for example.
365	Incorrect index.	A multiplex index is outside the defined range.
370	Hard copy print-out has been cancelled manually.	
371	Print function disabled at present.	
372	The function started has been cancelled.	
383	For information: transfer of data records completed.	
384	Data record required is not on data medium.	Check the data record selection parameters (recipe, data record name, data medium) or use the Select function to select the data record.
385	Information message: transfer of data records from OP to data medium or vice versa has been initiated.	One possible reason is that operation is no longer possible: The PLC has not reset the corresponding control and acknowledgment bit, which deactivates the recipe mailbox lock, in the interface area.
386	Information message: transfer of data records from OP to PLC or vice versa has been initiated.	
387	Data record not found.	There is no data record relating to the selected recipe on the data medium.
388	Activating selected function.	
389	De-activating selected function.	
391	No Help text configured.	Check configuration.

Message	Cause	Remedy:
442	Data block error x DB no. y This message indicates a data block error. The variables <b>x</b> and <b>y</b> identify the cause of the fault ( <b>X</b> ) and the number of the receive block concerned ( <b>Y</b> ). <b>Variable x:</b> 0 incorrect block length entered in receive block No. <b>y</b> . 1 incorrect block number entered in receive block No. <b>y</b> .	Correct the block length/block number as necessary or send the correct data block.
450	When entering a value, you have attempted to press a key that is not compatible with the defined input field.	
451	You have entered a setpoint that is below the configured lower limit.	Enter a value that is greater than or equal to the limit.
452	You have entered a setpoint that is above the configured upper limit.	Enter a value that is less than or equal to the limit.
453	Time not entered correctly.	Enter time correctly
454	Interface parameters incorrectly set, e.g. when specifying parameters for printer interface	Enter valid value for interface parameters. The following values are valid: – Baud rate: 300, 600, 1200, 2400, 4800, 9600, 19200 – Data bits: 5,6,7,8 – Stop bits: 1,2 – Timeout: 1...600
455	You have set graphics printing on the OP but the corresponding ESC sequence has not been configured.	Select a different printer or check printer configuration in ProTool.
456	You have entered an incorrect value, e.g. a variable with a user function that blocks certain input values.	Enter permissible value.
458	You have entered a value that is too great or too small for the variable type concerned, e.g. a value greater than 32767 for a variable of the type Integer.	Enter a value that is within the permissible range.
459	You are attempting to enter an illegal character (e.g. letter in a numerical value) The input is rejected and the existing entry retained.	Enter permissible value.
500...503	Scheduler, counter, date or time data can not be sent.	This error can occur if the PLC is temporarily overloaded or if the function block is not invoked for more than 1.5 s.
504	Free ASCII Protocol: operator input value could not be sent.	
505	The data record can not be sent as the recipe disable bit on the PLC is set or because transfer of a recipe is still in progress.	Try sending again later when the PLC has released the recipe mailbox.
506	Overload: too many message blocks with the same block number in transit.	This error occurs if the PLC sends too many jobs using 'collect message area' within a certain period of time.
507	Transfer of the data record was not acknowledged by the PLC within a certain period.	Checking of data records by the user at the PLC end must be carried out more quickly (< 10 s).
509	Firmware version is different from standard FB version.	Please contact the SIMATIC Hotline.

Message	Cause	Remedy:
510	Data record not present.	A process link with a non-existent data block has been configured in a recipe or the recipe data contains errors.
512	Configured data block length is too short. The variable transferred with the message identifies the number of the data block.	Change configuration and retransfer.
541 ... 550	Specified variable not available on PLC	Change configuration and retransfer.
551	An MPI/PPI connection to the PLC cannot be established using the specified station address.	Check MPI station addresses and wiring.
552	Query: safety check as to whether the selected data record is to be deleted. The data record is only deleted if 0 is entered. If not the function is cancelled.	This query is also used when backing up or restoring configurations. In that case, it relates to deletion of all data records in the system memory.
553	Information message: selected data record has been deleted.	
554	Query: 1st safety check as to whether the data medium for storing data records is to be formatted. Any data records already on the disk will be deleted when the function is executed! The function is only executed if 0 is entered.	
555	Query: 2nd safety check as to whether the data medium for storing data records is to be formatted. Any data records already on the disk will be deleted when the function is executed! The function is only executed if 0 is entered.	
556	Information message: disk has been formatted.	
557	Query: if 0 is entered the data record will be adopted with the new values. If anything else is entered, you may continue editing.	
558	Query: if 0 is entered the edited data record is rejected. The data remains as it was before editing. If anything else is entered, you may continue editing.	
559	Query as to whether the event message buffer should be cleared.	
560	Query as to whether the alarm message buffer should be cleared.	
561	A global data record (rel. 3.0 or higher) is being edited and does not have all the entries defined in the current recipe.	The data record can only be saved if the marked entries are edited. If no entries are marked, only the version number has changed.
562	Information as to which mode was set using the function "First/Last Message".	
563	Information as to which mode was set using the function "First/Last Message".	
564	Query: if 0 is entered the data record is created. If anything else is entered, the function is cancelled.	

Message	Cause	Remedy:
565	On transferring a global data record, it is established that not all entries are present. You have the following options: 1: read the missing entries from the PLC 2: edit the missing entries 3: cancel the Download operation.	Only returned in the case of data records that are transferable from one recipe to another. rel. 3.0 or higher, plastic functions.)
566	Data record contains array that does not fit the current recipe structure.	The following question appears: Save yes/no ? If you elect to save, the array data is set to 0.
567, 568	If the message buffer has to be cleared, pending event/ alarm messages also have to be deleted in order to make space for new message events.	Check configuration. Too many messages are pending.
569	Fault on CPI module.	<ul style="list-style-type: none"> <li>– CPI no.: defective CPI module</li> <li>– Error: <ul style="list-style-type: none"> <li>1 = Voltage too low</li> <li>2 = Current too high</li> <li>3 = Temperature too high</li> <li>4 = Module not present (failed during operation)</li> </ul> </li> </ul>
571	S7 system diagnosis/ALARM_S returns error if OP logs on/off.	CPU operating system out of date.
572	Query: data record already exists on data medium.	If 0 is entered the data record will be overwritten with the new values.
604	Message does not exist.	Configure message.
605	Process link is only configured symbolically.	Change configuration and retransfer.
606	Too many message variables configured.	
607	Data type configured does not exist.	
613	Data block not available or too short.	Create data block of required length on the PLC.
622	Configured recipe does not fit in recipe mailbox on PLC (> 512 data words).	Reduce configured size of recipe and retransfer configuration.
623	<i>Internal error</i> Screen object for "Send Recipe" is not a recipe type (fixed by COM TEXT).	If the fault is not corrected by performing a restart, please contact the SIMATIC Hotline.
624	No recipe entries found.	Set up area pointers and retransfer configuration.
625	Recipe number does not exist.	Reconfigure recipe.
626	No setpoints have been configured.	
627	<i>Internal error</i> Configured keyboard block number too high.	Correct the block number.
628	Recipe does not fit in mailboxes.	Increase configured size of recipe mailbox or succeeding recipe mailbox.

Message	Cause	Remedy:
636	Event message is not configured	Configure event message (-> message number) fully.
640	Alarm message is not configured	Configure alarm message (-> message number).
645	<i>Internal error</i> PLC co-ordination area not receivable during startup.	Press key to restart. If the fault is not corrected by performing a restart, please contact the SIMATIC Hotline.
649	<i>Internal error</i> Driver number configured can not be interpreted.	If the fault is not corrected by performing a restart, please contact the SIMATIC Hotline.
650	Missing area pointer.	Configure an area pointer.
653	The configured user version number does not match the version number stored on the PLC.	Change configuration and retransfer.
655	PLC acknowledgement area does not physically follow on from the alarm messages area (-> no startup).	
657	Configured PLC protocol is not possible.	Use current firmware version or configure different protocol.
667	Configuration error: <b>Variable x:</b> 1 Data type is not DB 2 DB number is greater than 15 3 DB length is greater than 1024 4 DW is in data block header 5 Actual value not in send block 6 Setpoint not in receive block 7 Setpoint/actual value not in receive block 8 Initial value not in send block 9 Data type is not DB 10 DB number is greater than 15 11 DB length is greater than 1024 12 DW is in data block header 13 Area is in wrong DB 14 Sum of data blocks too great	x = 1..8: Change the configuration of the process link and retransfer. x = 9..13: Change configuration of area pointer and retransfer x = 14: Restrict configuration and retransfer.
668	Incorrect configuration. Meaning of variables: 1: Incompatible PLC types configured 2: No PLC configured 3: Incorrect baud rate configured	Change configuration and retransfer.
669	Too many actual values (> 512) have been configured for cyclic reading in a screen/variable.	
670	Too many variables requested simultaneously.	Lengthen standard clock pulse or configure fewer variables on screen.
671	Configuration of message variables incompatible. Differences between configuration and PLC.	Check S7 programs, check message server configuration, modify configuration and download again.
672	Message not configured.	
680	Selection of a recipe not defined in the project.	Select a valid recipe.

Message	Cause	Remedy:
681	Overload caused by too many variables (setpoints/actual values). Fault in connection between the OP and PLC.	Check the interface parameters.
682	Incorrect interface parameters configured.	Configure fewer process links for the screen displayed.
683	Configuration error: upper limit = lower limit	Correct the limits and retransfer configuration.
684	Non-existent trend switch buffer requested.	Check PLC program/OP configuration.  Only use trend request area 2 for trends with switch buffer.
701	<i>Internal error</i> Incorrect assignment of "head -> res" when receiving variable.	
702	Job can not be executed.	Change interface or configure area pointer.
703	Flash memory full.	Restrict the configuration.
704	Incorrect CPU specified under "PLC -> Parameters".	Change configuration and retransfer.
706	Recipe request will not be processed as another request is already active.	
722	<i>Internal error</i> Incorrect mailbox type received (OP15 -> OP5)	
723	<i>Internal error</i> OP5: more than 500 messages are specified in the area pointer lists.	Change area pointer list.
724	<i>Internal error</i> Mailbox type not implemented.	
771	<i>Internal error</i> Error during communication (-> messages).	
779	<i>Internal error</i> Internal error during MPI download; possibly due to buffer problems.	Reset and repeat MPI download.
780	<i>Internal error</i> Undefined error from communication with PLC.	
781	An "Online Setter" function has been incorrectly defined in ProTool.	

**Procedure for  
"internal errors"**

In the case of all system messages that relate to "internal errors", please follow the procedure outlined below.

- a) Switch off the OP, set the PLC to STOP mode and then restart both units.
- b) During startup, set the OP to download mode, download the configuration again and then restart the OP and PLC again.
- c) If the fault recurs, please contact your nearest Siemens representative. When doing so, please quote the number of the error that has occurred and any variables referred to in the message.

# SIMATIC HMI Documentation

# D

## Target groups

This manual is part of the SIMATIC HMI documentation. The documentation is aimed at the following target groups:

- Newcomers
- Users
- Configurers
- Programmers
- Commissioning engineers

## How the documentation is organized

The SIMATIC HMI documentation consists of the following components:

- User's Guides / User's Manuals for:
  - Configuration software
  - Runtime software
  - Communication between PLCs and operating units
- Equipment Manuals for the following operating units:
  - MP (Multi Panel)
  - OP (Operator Panel)
  - TP (Touch Panel)
  - TD (Text Display)
  - PP (Push Button Panel)
- Online Help on the configuration software
- Start-up Guides
- First Steps

## Overview of complete documentation

The following table provides an overview of the SIMATIC HMI documentation and shows you when you require the different documents.

Documentation	Target Group	Content
First Steps with ProTool Product Brief	Newcomers	<p>This documentation guides you step by step through the configuration of</p> <ul style="list-style-type: none"> <li>• a screen with various objects</li> <li>• changing from one screen to another</li> <li>• a message.</li> </ul> <p>This documentation is available for:</p> <ul style="list-style-type: none"> <li>• OP3, OP5, OP7, OP15, OP17</li> <li>• OP25, OP27, OP35, OP37, TP27, TP37</li> <li>• Windows-based systems</li> </ul>
ProTool Configuring Windows-based Systems User's Guide	Configurers	<p>Provides information on working with the ProTool/Pro configuration software. It contains</p> <ul style="list-style-type: none"> <li>• information on installation</li> <li>• basic principles of configuration</li> <li>• a detailed description of configurable objects and functions.</li> </ul> <p>This documentation is valid for Windows-based systems.</p>
ProTool Configuring Graphics Displays User's Guide	Configurers	<p>Provides information on working with the ProTool configuration software. It contains</p> <ul style="list-style-type: none"> <li>• information on installation</li> <li>• basic principles of configuration</li> <li>• a detailed description of configurable objects and functions.</li> </ul> <p>This documentation is valid for graphic display operating units.</p>
ProTool Configuring Text-based Displays User's Guide	Configurers	<p>Provides information on working with the ProTool/Lite configuration software. It contains</p> <ul style="list-style-type: none"> <li>• information on installation</li> <li>• basic principles of configuration</li> <li>• a detailed description of configurable objects and functions.</li> </ul> <p>This documentation is valid for text-based display operating units.</p>
ProTool Online Help	Configurers	<p>Provides information on the configuration computer while working with ProTool. Online Help contains</p> <ul style="list-style-type: none"> <li>• context-sensitive help</li> <li>• detailed instructions and examples</li> <li>• detailed information</li> <li>• all the information from the user guide.</li> </ul>
ProTool/Pro Runtime User's Guide	Commissioning engineers, Users	<p>Provides information on working with ProTool/Pro Runtime software. It contains</p> <ul style="list-style-type: none"> <li>• installation of the ProTool/Pro Runtime visualization software</li> <li>• commissioning and running the software on Windows-based systems.</li> </ul>
Copy Protection Start-up Guide	Commissioning engineers, Users	<p>The ProTool/Pro Runtime visualization software is a copyright product. This manual contains information on the installation, repair and uninstallation of authorizations.</p>

Documentation	Target Group	Content
Application Example Start-up Guide	Newcomers	ProTool is supplied with example configurations and the corresponding PLC programs. This documentation describes how you <ul style="list-style-type: none"> <li>load the examples onto the operating unit and PLC</li> <li>run the examples and</li> <li>upgrade the connection to the PLC to suit your own specific application.</li> </ul>
MP270 Equipment Manual	Commissioning engineers, Users	Describes the hardware and the general operation of Multi Panel MP270. It contains <ul style="list-style-type: none"> <li>installation and commissioning instructions</li> <li>a description of the equipment</li> <li>operating instructions</li> <li>instructions for connecting the PLC, printer and programming computer,</li> <li>maintenance instructions.</li> </ul>
OP37/Pro Equipment Manual	Commissioning engineers, Users	Describes the hardware, installation and inclusion of upgrades and options for the OP37/Pro.
TP27, TP37 Equipment Manual OP27, OP37 Equipment Manual OP25, OP35, OP45 Equipment Manual OP7, OP17 Equipment Manual OP5, OP15 Equipment Manual TD17 Equipment Manual	Commissioning engineers, Users	Describes the hardware and general operation. It contains <ul style="list-style-type: none"> <li>installation and commissioning instructions</li> <li>operating unit description</li> <li>connecting the PLC, printer and programming computer</li> <li>operating modes</li> <li>operation</li> <li>description of the standard screens supplied with the operating unit and how to use them</li> <li>fitting options</li> <li>maintenance and fitting of spare parts.</li> </ul>
OP3 Equipment Manual	Commissioning engineers, Users, Programmers	Describes the hardware of the OP3, its general operation and the connection to the SIMATIC S7.
PP7, PP17 Equipment Manual	Commissioning engineers, Users	Describes the hardware, installation and commissioning of push-button panels PP7 and PP17.
Communication User's Manual	Programmers	Provides information on connecting text-based and graphics displays to the following PLCs: <ul style="list-style-type: none"> <li>SIMATIC S5</li> <li>SIMATIC S7</li> <li>SIMATIC 500/505</li> <li>drivers for other PLCs</li> </ul> This documentation describes the <ul style="list-style-type: none"> <li>configuration and parameters required for connecting the devices to the PLC and the network</li> <li>user data areas used for exchanging data between operating unit and PLC.</li> </ul>

Documentation	Target Group	Content
Communication for Windows-based Systems User's Manual	Programmers	<p>Provides information on connecting Windows-based systems to the following PLCs:</p> <ul style="list-style-type: none"> <li>• SIMATIC S5</li> <li>• SIMATIC S7</li> <li>• SIMATIC 505</li> <li>• Allen Bradley PLC 5/SLC 500</li> </ul> <p>This documentation describes the</p> <ul style="list-style-type: none"> <li>• configuration and parameters required for connecting devices to the PLC and the network</li> <li>• user data areas used for exchanging data between operating unit and PLC.</li> </ul>
Other PLCs Online Help	Programmers	<p>Provides information on connecting devices to PLCs, such as:</p> <ul style="list-style-type: none"> <li>• Mitsubishi</li> <li>• Allen Bradley</li> <li>• Telemecanique</li> <li>• Modicon</li> <li>• Omron</li> <li>• SIMATIC WinLC</li> </ul> <p>When the drives are installed, the relevant Online Help is installed at the same time.</p>
ProAgent for OP User's Manual	Configurers	<p>Provides the following information about the ProAgent optional package (process diagnosis) for OPs</p> <ul style="list-style-type: none"> <li>• configuring system-specific process diagnosis</li> <li>• detecting, locating the cause of and eliminating process errors,</li> <li>• customizing standard diagnostic screens supplied with the software.</li> </ul>

## ESD Guidelines

### What does ESD mean?

Virtually all present-day modules incorporate highly integrated MOS devices or components. For technological reasons, these electronic components are very sensitive to overvoltages and consequently therefore to electrostatic discharge:

These devices are referred to in German as Elektrostatisch Gefährdeten Baelemente/ Baugruppen: "EGB"

The more frequent international name is:

"ESD" (Electrostatic Sensitive Device)

The following symbol on plates on cabinets, mounting racks or packages draws attention to the use of electrostatic sensitive devices and thus to the contact sensitivity of the assemblies concerned:

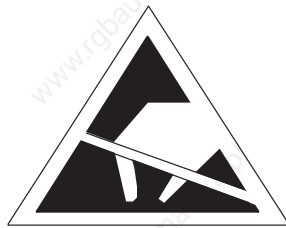

**ESDs** may be destroyed by voltages and energies well below the perception threshold of persons. Voltages of this kind occur as soon as a device or an assembly is touched by a person who is not electrostatically discharged. Devices exposed to such overvoltages cannot immediately be detected as defective in the majority of cases since faulty behavior may occur only after a long period of operation.

### Precautions against electrostatic discharge

Most plastics are capable of carrying high charges and it is therefore imperative that they be kept away from sensitive components.

When handling electrostatic sensitive devices, make sure that persons, workplaces and packages are properly grounded.

### **Handling ESD assemblies**

A general rule is that assemblies should be touched only when this cannot be avoided owing to the work that has to be performed on them. Under no circumstances should you handle printed-circuit boards by touching device pins or circuitry.

You should touch devices only if

- you are grounded by permanently wearing an ESD wrist strap or
- you are wearing ESD shoes or ESD shoe-grounding protection straps in conjunction with an ESD floor.

Before you touch an electronic assembly, your body must be discharged. The simplest way of doing this is to touch a conductive, grounded object immediately beforehand – for example, bare metal parts of a cabinet, water pipe etc.

Assemblies should not be brought into contact with charge-susceptible and highly insulating materials such as plastic films, insulating table tops and items of clothing etc. containing synthetic fibers.

Assemblies should be deposited only on conductive surfaces (tables with an ESD coating, conductive ESD cellular material, ESD bags, ESD shipping containers).

Do not place assemblies near visual display units, monitors or television sets (minimum distance to screen > 10 cm).

### **Measuring and modifying ESD assemblies**

Perform measurements on ESD assemblies only when

- the measuring instrument is grounded – for example, by means of a protective conductor – or
- the measuring head has been briefly discharged before measurements are made with a potential-free measuring instrument – for example, by touching a bare metal control cabinet.

When soldering, use only grounded soldering irons.

### **Shipping ESD assemblies**

Always store and ship assemblies and devices in conductive packing – for example, metallized plastic boxes and tin cans.

If packing is not conductive, assemblies must be conductively wrapped before they are packed. You can use, for example, conductive foam rubber, ESD bags, domestic aluminum foil or paper (never use plastic bags or foils).

With assemblies containing fitted batteries, make sure that the conductive packing does not come into contact with or short-circuit battery connectors. If necessary, cover the connectors beforehand with insulating tape or insulating material.

# Glossary

## A

### **Alarm message**

Calls attention to high-priority operating states and has therefore to be acknowledged.

### **Alarm time**

Time between the arrival and departure of an alarm message.

### **Area pointer**

Required for data exchange between the TP and the PLC. It contains information concerning the length and size of data areas on the PLC.

### **Arrival of a message**

The point in time at which a message is issued by the PLC or TP.

### **Automation systems**

PLCs of the SIMATIC S7 series – for example, SIMATIC S7-200/300/400)

## B

### **Blanking**

Automatic turn-off of display back lighting.

### **Boot**

A load operation which transfers the operating system to working memory on the TP.

### **Button**

Touch-sensitive area on the screen of a Touch Panel with configured functionality. Buttons replace, among other things, system keys and function keys on the TP37.

## C

### **Configuration**

Definition of system-specific basic settings, messages and screens using the ProTool configuration software.

### **Control Panel Interface**

Option for Touch Panel with 16 (TP27–6) or 32 TP27–10/TP37) digital input/outputs for fast key input without any communication–based delay. Can be used with SIMATIC S/ and PROFIBUS–DP.

## D

### **Departure of a message**

The point in time at which a message is withdrawn by the PLC.

### **Display function**

Function causing the contents of the display to be modified – for example, Display Message Level, Display Alarm Buffer And Display Process Screen.

### **Download mode**

Operating mode of the TP during which data are downloaded from the PU or PC to the TP.

### **Duration of display**

The time between the arrival and departure of a message.

## E

### **Event message**

Draws attention to specific operating states on machines or systems connected to the PLC.

## F

### **Field**

Reserved area in configured and non-configurable text for the output and/or input of values.

### **Flash memory**

Programmable memory which can quickly be deleted and then re-written.

## H

### **Help text**

Additional, configurable information for messages, screens, screen entries and list boxes.

**L****Loop-through mode**

Operating mode of the TP. It covers normal operation and also handles communication between a PU or PC and the PLC via the TD. This operating mode is only possible when connection to the PLC is made via the AS511 protocol.

**M****Message log**

Printout of alarm messages and event messages simultaneously with their output to the display.

**N****Normal mode**

Operating mode of the TP during which messages can be displayed and screens can be controlled by the operator.

**O****Output field**

Field for displaying a setpoint.

**P****Password, Password level**

To control a protected function, a password of a specific password level has to be entered. The password level determines the privileges of the operator. The requisite password level can be configured, 0 being the lowest level and 9 the highest.

**PLC**

Generic term for devices and systems with which the TP communicates – for example, SIMATIC S5/S7 or PCs).

**PLC job**

Function triggered by the PLC.

**Printout**

Output of the contents of the display to an attached printer.

**Process screen**

Representation of process values and process sequences in the form of screens, which may contain graphics, pieces of text and values.

## S

**Screen** Form of displaying logically associated process data which may be shown collectively on the TP and modified individually.

**Selection field** Field for the value setting of a parameter (one value can be selected as the default value).

**Startup test** Checks the state of the CPU and memories every time the power supply voltage is turned on.

**System message** Calls attention to internal states on the TP and on the PLC.

## T

**Touch Panel** An Operator Panel without a keyboard. A Touch Panel is operated by means of its touch-sensitive screen.

# Index

## A

- Access permissions, 5-1
- Access protection, 5-1
- Acknowledge, alarm message, 6-2, 6-4, 6-6
- Acknowledged, message, 6-1, 6-9
- Acknowledgement, on contact, 3-4
- Acknowledgment group, 6-6, 6-9
  - alarm message, 2-1
  - set, 6-27
- Acoustic acknowledgment, 3-4
- Acoustic signal, 11-8
- Additional information, 1-4
- Alarm message, 1-4, 2-1, 6-2, 6-6
  - acknowledging, 6-4, 6-6
  - displaying help text, 6-4
  - send to background, 6-4
- Alarm message buffer
  - deleting, 6-25
  - opening, 6-7, 6-13, 6-25
  - print, 6-25
- Alarm message page, opening, 6-11
- Alarm message screen, opening, 6-7, 6-25
- Alarm message window, 6-4
- ALARM\_S Messages, 6-18
  - buffer overflow, 6-23
    - deleting messages, 6-23
    - message archive, 6-23
    - overflow warning, 6-23
    - printout, 6-23
  - communication sequence, 6-19
    - Anmelden, 6-19
    - information stored, 6-19
    - time stamp, 6-19
    - when a message event occurs, 6-19
  - incorporate, 6-18
  - message acknowledgement, 6-20
  - message logging, 6-20
  - message overload, 6-21
  - overload
    - communication, 6-21
    - CPU memory, 6-21
    - operating unit, 6-21
    - printing messages, 6-20

- Printing messages in the event of a buffer
  - overflow, 6-20
  - updating, 6-22
  - use of resources, 6-18
- Alphanumeric keyboard, 3-8
  - cancel entry, 3-9
  - confirm entry, 3-9
  - cursor left, 3-9
  - cursor right, 3-9
  - display help text, 3-8
  - entering values, 3-8
  - keyboard levels, 3-9
- Alphanumeric keypad, entering characters, 3-8
- Ambient conditions, A-3
- Angle of inclination, 12-1, A-3
- Applications, 1-1
- Appropriate installation, 12-1
- Arrived, message, 6-1, 6-9
- AS511, connection, 14-3, 15-4, 16-6
- ASCII
  - character set, 12-12
  - print screen, 7-4
- Assembly, 12-2, 12-3
- Assign, printer colors, 7-4
- Assignment, interfaces, B-1
- Authorization, 5-1

## B

- Back-lighting, 11-5, A-2
  - replacing, 18-4, 18-5
- Background color
  - button, 3-5
  - input field, 3-6
- Backspace, 3-7
- Backup, 2-3
  - flash module, 9-6
- Backup battery, A-2
  - changing, 18-2
- Backup/Restore, standard screen, 9-5
- Bar graph, 1-3
- Barometric pressure, A-3
- Basic functions, 1-3

Battery compartment, 18-3  
Baud rate, printer, 7-3  
Blanking, screen, 11-5  
Boot operation, 13-6  
Bordercolor, button, 3-5  
Bottling machine, example, 8-1  
Brightness, back-lighting, 18-4  
Buffer overflow, ALARM\_S Messages, 6-23  
Burst interference, A-4  
Button, 3-1, 3-2, 4-2

## C

Calibrating, touch screen, 11-7  
Calibration error, 11-7  
Calibration window, 11-7  
Call, function, 4-5  
Calling, help text, 3-11, 4-5  
Cancel, input, 3-8, 3-9  
Capacity  
    backup battery, A-2  
    message buffer, 2-1  
Category  
    messages, 6-2  
    system message, C-1  
Cause of malfunction, acknowledging, 6-6  
Causes, system message, C-2  
Centronics interface, B-3  
Certifications, A-4  
Change  
    backup battery, 18-2  
    language, 11-8  
    operating mode, 11-4  
    password, 5-6  
    password level, 5-6  
Character, delete, 3-7  
Character alignment, 3-7  
Character sets, 2-3  
    number, 2-3  
Character size, character set, 2-3  
Chassis ground, 12-8, 15-3  
Chemical resistance, A-5, A-8  
Clean, screen, 11-6, 18-1  
Cleaning agents, 18-1  
Clear, 3-7  
Cleared, message, 6-1, 6-9  
Clock frequency, A-1  
Close, event message window, 6-5  
Closing, help window, 3-11  
Color  
    button, 3-5  
    input field, 3-6  
    Color assignment, printer, 7-4  
Combination  
    Message window/Message line, 6-3  
    variables, 8-1  
Commissioning, 13-1  
Communication, 1-2, 2-4  
Communication options, 16-6  
    TP27-10, 15-4  
    TP27-6, 14-3  
Communication sequence, ALARM\_S Messages, 6-19  
Compress, internal program memory, 13-2  
Concept, operating, 3-1  
Condensation, 12-1  
Conduction, RF, A-4  
Configuration, 1-2  
    downloading, 13-3  
    testing, 13-9, 13-10  
Configuration computer, 1-2  
    connecting, 12-9  
Configuration data, download, 1-2  
Configuration options, 12-7  
Configuration software, 1-1  
Configuration using ProTool, 1-2  
Configuring, IF1B interface, 12-11  
Connecting  
    light, siren etc., 12-8  
    PU or PC, 12-9  
Connection  
    battery, 14-2, 15-3, 16-5, 18-2  
    configuration computer, 12-9  
    electrical, 12-6  
    ground, 12-8  
    options, 12-10  
    PLC, 12-10  
    power supply, 12-8  
    printer, 12-12, 14-3, 15-4, 16-6  
Connection configuration, printer, 12-12  
Connection configuration diagram  
    configuration computer, 12-9  
    PLC, 12-10  
    printer, 12-12  
Connection elements  
    TP27-10, 15-3  
    TP27-6, 14-2  
    TP37, 16-5  
Consequential malfunction, acknowledging, 6-6  
Contact discharge, A-4  
Control panel interface, 1-6, 17-6  
    connector pin assignemnt, 17-10  
    connectors and adjusters, 17-9  
    installing, 17-7

- Correct, parallax, 11-7
- Create
  - data record, 8-9
  - password, 5-5
  - record set, 8-16
- CSA certification, A-4
- Cursor, 3-10
  - move left, 3-9
  - move right, 3-9
- D**
- Data
  - loading, 9-1
  - storing, 9-1
  - technical, A-1
- Data areas, set up, 1-2
- Data bits, printer, 7-3
- Data medium, 9-1
  - format, 8-8
- Data record
  - creating, 8-9
  - deleting, 8-12
  - download, 8-11
  - editing, 8-9
  - load, 8-11, 8-14
  - save, 8-11, 8-14
  - update, 8-13
- Data Record Processing and Transmission, standard screen, 8-6
- Data records, 8-1
- Data structure, 1-4, 8-1
- Data types, 9-1
- Date
  - message, 6-4
  - set, 6-27
- Date/time, setting, 11-8
- Deactivate, touch screen, 11-6
- Decimal format, 3-7
- Decimal point, entering, 3-7
- Degree of protection, 12-1, A-1
- Delete
  - alarm message buffer, 6-25
  - character, numeric keypad, 3-7
  - data medium, 9-3
  - data record, 8-12
  - event message buffer, 6-25
  - input line, numeric keypad, 3-7
  - messages, 6-14, 6-15
  - password, 5-6
  - record set, 8-17
- Deleting messages, buffer overflow, 6-14
- Departed, message, 6-1, 6-9
- Description, TP, 14-1, 15-1, 16-1
- Design, interference-free, 12-6
- Device variants, 1-1
- Digital outputs, 17-1, 17-6
- DIL switch
  - direct key module, 17-5
  - IF1B interface, 12-11, 14-2, 15-3, 16-5
- Dimensions, A-1
  - TP27-10, 15-2
  - TP27-6, 14-1
  - TP37, 16-2
- Direct key module, 1-6, 17-1
  - connectors and adjusters, 17-4
  - installing, 17-2
  - pin array pin assignment, 17-5
- Direct message logging, 6-16
- Disable
  - message logging, 6-16, 6-28
  - overflow warning, 6-29
- Discharge, static, A-4
- Display, 1-5, 2-3, A-2
  - alarm messages, 2-1
  - backlit, 1-5
  - colors, 1-5
  - event messages, 2-1
  - fill level, 1-3
  - first message, 6-11
  - graphic elements, 1-3
  - last message, 6-11
  - messages, 6-9
  - pressure variation, 1-3
  - quantities, 1-3
  - resolution, 1-5
  - size, 1-5
  - temperature variation, 1-3
  - touchscreen, 1-5
  - type, 1-5
- Display elements, TP37, 16-3
- Display functions, 1-3
- Display mode, messages, 6-3
- Display type, alarm messages, 2-1
- Disposal, lithium battery, 18-3
- Documentation, D-1
- Download
  - configuration data, 1-2, 13-3
  - data record, 8-11
  - firmware, 13-3
  - serial, 13-4
- Download mode, 11-4, 13-3
- Download Selective Data Record, standard screen, 8-4

DRAM, A-1

## E

Edit

- data record, 8-9
- password, 5-6
- record set, 8-15

Edit Message, standard screen, 6-15

Edit Password, standard screen, 5-2

Edit window, data records, 8-10

Electrical connections, 12-6

Electrical installation, 12-6

EMC-compatible installation, 12-6

Enable

- message logging, 6-16, 6-28
- overflow warning, 6-29

Enlarge, memory area, 9-4

ENTER, 3-7, 3-9

Enter

- alphanumeric values, 3-8
- password, 5-3
- value, 3-6

Entry

- cancel, 3-9
- confirm, 3-9

Error handling, C-12

Errors, internal, C-12

ESC, 3-7, 3-9

ESD Guidelines, E-1

Event message, 1-4, 2-1, 6-2

- inhibiting, 6-3

Event message buffer

- deleting, 6-25
- opening, 6-13, 6-25
- print, 6-25

Event message page, opening, 6-11, 6-25

Event message window, 6-5

- opening, 6-5, 6-25

External dimensions, A-1

External power supply, 17-1, 17-6

## F

Fan, 12-8

FAP connection, 14-3, 15-4, 16-6

Fill level, display, 1-3

Firmware, 12-6

- downloading, 13-3

First message, display, 6-11

Fitting, TP37, 12-5

Fixation

TP27-10, 12-3

TP27-6, 12-2

Fixed window, 3-1, 3-2

Flash, 1-6, 9-1

- delete, 9-3

Flash memory, A-1

Fluorescent tube, 18-4

FM certification, A-4

Force Variable, 10-1

- control sequence, 10-6

- standard screen, 10-2, 10-5

Forced printout, automatic, buffer overflow, 6-14

Foreground color

- button, 3-5
- input field, 3-6

Format

- data medium, 8-8
- password, 5-2

Front view

- TP27-10, 15-2
- TP27-6, 14-1
- TP37, 16-2

Function

- call, 4-5
- password management, 5-5
- trigger, 3-4

Functionality, 2-1

Fuse, A-2

## G

General operation, 3-1

Generate, data record, 8-9

Global button, 3-2

Graphic, print screen, 7-4

Graphic elements, display, 1-3

Grounding connection, 14-2, 16-5

Grounding screwdriver, 12-8

Group acknowledgement, 6-6

## H

Hand symbol, 3-5

Hardware clock, 18-2

HELP, 3-7, 3-8, 3-11, 6-4

Help text, 1-4, 2-2, 3-8, 3-9, 3-11

- calling, 4-5
- display, 3-8
- displaying, 3-7, 6-4

- Help window, 3-1, 3-3
    - closing, 3-11
  - HEX, 3-7
  - Hexadecimal mode, 3-7
  - Hide
    - event messages, 6-3
    - system message, 6-8
  - Hierarchy
    - passwords, 5-1
    - standard screens, 4-4
  - Hints on operation, messages, 6-2
  - Housing, A-1
  - Humidity, A-3
- I**
- Identify, recipe, 8-2
  - IF1A interface, 14-2, 15-3, 16-5
    - assignment, B-1
  - IF1B interface, 14-2, 15-3, 16-5
    - assignment, B-2
  - IF2 interface, 14-2, 15-3, 16-5
    - assignment, B-1
  - IF3 interface, 16-5
    - assignment, B-2
  - Incorporating, ALARM\_S Messages, 6-18
  - Indicator, alarm messages, 6-6, 6-7
  - Indicators, 1-5
  - Information text, 3-11
  - Ingredients, recipe, 8-2
  - Inhibit, event message, 6-3
  - Initial startup, 13-1, 13-3
  - Initialize, TP, 13-8
  - Input
    - cancel, 3-7, 6-4
    - confirm, 3-7
    - numerical value, 3-6
    - symbolic value, 3-10
  - Input field, 1-3, 3-6, 4-2
  - Input line, delete, 3-7
  - Input window, 3-1, 3-3
    - numeric input, 3-6, 3-8
    - symbolic input, 3-10
  - Insert, memory card, 9-6
  - Installation, 12-1
    - electrical, 12-6
    - mechanical, 12-2
    - TP27-10, 12-3
    - TP27-6, 12-2
    - TP37, 12-5
  - Installation conditions, 12-1
  - Installation position, 12-1
  - Installation possibilities, 1-1
  - Interface, 1-5
    - control panel interface, 14-2, 15-3, 16-5
    - direct key module, 14-2, 15-3, 16-5
    - IF1A, 14-3, 15-4, 16-6, B-1
    - IF1B, 12-11, 14-3, 15-4, 16-6, B-2
    - IF2, 14-3, 15-4, 16-6, B-1
    - IF3, B-2
    - LPT, 16-6, B-3
    - MPI, 14-3, 15-4, 16-6
    - parallel, 16-5
    - PPI, 14-3, 15-4, 16-6
    - serial, 14-2, 15-3, 16-5
  - Interface assignment, B-1
  - Interference-free design, 12-6
  - Internal errors, C-12
  - Internal operating state, 6-8
  - Irradiation, RF, A-4
  - Issue, password, 5-5
- J**
- Job, from PLC, 4-2
- K**
- Keyboard, 1-1
    - switchover, 3-9
  - Keypad, 3-6
  - Keys, virtual, 3-1
- L**
- Labeling, buttons, 3-2
  - Language, 1-4
    - changing, 2-3, 11-8
    - number, 2-3
  - Last message, display, 6-11
  - LCD back-lighting, 11-5, 18-4
  - LED, 1-5, 16-3, 16-4
  - Length
    - alarm messages, message text, 2-1
    - event messages, message text, 2-1
  - Light indicators, 3-2
  - Lighting, screen, 11-5
  - Limit value monitoring, 2-2
  - Line, messages, 6-3

Lines per message  
alarm messages, message text, 2-1  
event messages, message text, 2-1

List

passwords, 5-7  
printers, 7-3  
system messages, C-1

Literature, D-1

Lithium battery, 18-3

Load

data, 9-1  
data record, 8-11, 8-14  
record set, 8-16

Local button, 3-2

Location, A-3

Logging, messages, 6-16

Logging out, from TP, 5-4

Logical connection, TP – PLC, 11-4

Login, 5-3

Logout, 5-4

Loudspeaker, 11-8

LPT, parallel interface, 16-5

LPT interface, assignment, B-3

**M**

Main area, 3-1, 3-2

Main memory, 1-6

Main screen, 4-3

Maintenance, 18-1

Management, passwords, 5-5

Mechanical installation, 12-2

Memory, 1-6, A-1

Memory area, reserved , 9-4

Memory card, 9-2, A-1

delete, 9-3

inserting, 9-6

Message, 1-4, 6-1

delete, 6-14, 6-15

display, 6-3, 6-9

printing, 6-16

type, 6-2

Message acknowledgement, ALARM\_S Messages, 6-20

Message acquisition, 2-2

Message archive, 6-9

Message bit procedure, 6-5

Message buffer, 1-4, 2-1, 6-5, 6-13

opening, 6-13

Message display, setting, 6-28

Message event, 2-2, 6-5

acknowledgment of alarm message, 6-5

arrival of message, 6-5

clearing of a message, 6-5

number, 2-1

printing, 1-4

set, 6-27

Message indicator, 3-3, 6-6, 6-7

Message line, 2-1, 6-3, 6-4

Message logging, 2-1, 6-16

enabling and disabling, 6-28

Message number, 6-4, 6-9, C-1

Message overload, ALARM\_S Messages, 6-21

Message page, 2-1, 6-11

opening, 6-11

Message relay, A-2

Message states, 6-1

Message window, 3-3, 6-3, 6-4

Mixing unit, example, 4-1, 4-2

Message text, 6-9

Models, 1-5

Modify

memory addresses, 13-2

record set, 8-17

Monitor, temperature, 12-8

Mounting cutout, A-1

TP27-10, 15-2

TP27-6, 14-1

TP37, 16-2

Mounting depth, A-1

Mounting location, 12-1

MPI, connection, 14-3, 15-4, 16-6

MPI download, 13-6, 13-7

Multiple languages, 1-4

**N**

NATIVE driver, 2-4

Noise immunity, A-4

Non-Siemens PLC, connection, 14-3, 15-4, 16-6

Normal operation, 13-1

**Number**

- alarm messages, 2-1
- character sets, 2-3
- characters
  - alarm message, 2-1
  - event message, 2-1
- data records per recipe, 2-3
- entries per data record, 2-3
- event messages, 2-1
- languages, 2-3
- message, 6-4, 6-9
- password levels, 2-2
- passwords, 2-2
- recipes, 2-3

**Numeric keypad**

- canceling input, 3-7
- changing sign, 3-7
- changing to hexadecimal mode, 3-7
- confirming input, 3-7
- deleting characters, 3-7
- deleting input line, 3-7
- displaying help text, 3-7
- entering decimal point, 3-7
- entering digits, 3-7
- entering hex numbers, 3-7

**Numerical value entry, 3-6****O****Offline mode, 11-4****Online mode, 11-4****Open**

- alarm message buffer, 6-7, 6-25
- alarm message screen, 6-7, 6-25
- event message buffer, 6-25
- event message page, 6-25
- event message window, 6-5, 6-25
- help window, 3-11
- message buffer, 6-13
- message page, 6-11

**Operate**

- process, 1-3
- touch element, 3-4

**Operating, touch panel, 1-1****Operating concept, 3-1****Operating elements, 1-4**

- TP27-10, 15-3
- TP27-6, 14-2
- TP37, 16-3

**Operating functions, 1-3****Operating mode, setting, 11-4****Operating state, internal, 6-8****Operating status, TP, 16-3****Operating temperature, A-3****Operation, general, 3-1****Operation acknowledgement, 3-4****Operator permission, 5-1****Operator process control, 1-4****Operator prompting, 2-2****Options, 17-1****Other PLCs, connection, 14-3, 15-4, 16-6****Output field, 1-3****Output medium, set, 6-27****Overflow warning, 6-5**

- enabling and disabling, 6-29

- switch on/off, 6-14

**Overview, 1-5****Overwrite, password, 5-6****P****Parallax, correcting, 11-7****Parallel interface, LPT, 16-5****Parallel printer connection, 12-12****Parameter, printer, 7-3****Parity, printer, 7-3****Partitioning, screen, 3-1****Password**

- changing, 5-6

- creating, 5-5

- deleting, 5-6

- enter, 5-3

- format, 5-2

- number, 2-2

- supervisor, 5-2

**Password hierarchy, 5-1****Password level, 5-1**

- changing, 5-6

- number, 2-2

**Password list, view, 5-7****Password management, 5-5****Password protection, 1-4, 2-2, 5-1****PC, connecting, 12-9****PC/PU, connecting, 14-3, 15-4, 16-6****PCMCIA, 14-2, 15-3, 16-5****Permission, password protection, 5-1****Plan view**

- TP27-10, 15-2

- TP27-6, 14-1

- TP37, 16-2

**PLC, connecting, 12-10****PLC job, 4-2****Pocket calculator format, 3-7****Position, window, 3-3**

Power consumption, A-2  
Power supply, 14-2, 15-3, 16-5, A-2  
    connecting, 12-8  
Power supply unit, 12-8  
PPI, connection, 14-3, 15-4, 16-6  
Presentation, message, 6-3  
Pressure variation, display, 1-3  
Principle  
    data storage, 9-2  
    enter value, 3-6  
Print  
    alarm message buffer, 6-25  
    buffer, 7-1  
    event message buffer, 6-25  
    messages, 6-14, 6-16, 7-1  
    screen list, 7-1  
Print functions, 2-2, 7-1  
Print screen, parameters, 7-4  
Printer, 7-3  
    connecting, 12-12, 14-3, 15-4, 16-6  
Printer interface, set, 7-3  
Printer Settings, standard screen, 7-2  
Printing messages, ALARM\_S Messages, 6-20  
Priority, 6-10  
    set, 6-27  
Process  
    control, 1-1, 4-1  
    monitoring, 1-1, 4-1  
    operating, 1-3  
    visualize, 1-3  
Process control phase, 1-2  
Process disturbance, reporting, 6-2  
Process state, reporting, 6-2  
Process values  
    alarm messages, 2-1  
    event messages, 2-1  
    messages, 6-4  
Process variable, visualizing, 1-1  
Processor, 1-6  
Processor type, A-1  
Product description, 1-1  
PROFIBUS-DP, 14-3, 15-4, 16-6  
Protective foil, 18-1  
ProTool, 1-1  
PU, connecting, 12-9  
Pulse modulation, A-4

## Q

Quantities, display, 1-3

## R

Radio interference, A-4  
Rated voltage, A-2  
Recipe, 1-4, 2-3, 8-1  
    identifying, 8-2  
Recommissioning, 13-1, 13-4  
Record sets, 8-15  
Recording, 1-4  
Relative humidity, A-3  
Relay contact, 12-8, A-2  
    message relay, A-2  
    with current supply, A-2  
Relay output, 14-2, 16-5  
    for temperature monitoring, 16-5  
Release, button, 3-4  
Remaining buffer size, 6-5, 6-14  
Remedies, system message, C-2  
Replace, back-lighting, 18-4, 18-5  
Report, process state, 6-2  
Reserved memory area, 9-4  
Resistance, chemical influences, A-5, A-8  
Resolution, screen, A-2  
Restore  
    configuration, another unit, 9-7  
    firmware/configuration, 9-7  
    module – flash, 9-6  
RF conduction, A-4  
RF irradiation, A-4  
RFI suppression, A-4  
RS232, connection, 14-3, 15-4, 16-6  
RS422, connection, 14-3, 15-4, 16-6  
RS485, connection, 14-3, 15-4, 16-6  
RTS signal, 12-11

## S

Save  
    data record, 8-11, 8-14  
    record set, 8-16  
Screen  
    blanking, 11-5  
    cleaning, 18-1  
    select, 4-2  
Screen elements, 4-1  
Screen list, print, 7-1  
Screen partitioning, 3-1  
Screen saver, 11-5  
Screen sections, 4-1  
Screens, 1-3, 2-2, 4-1

- Screw-type clamp, 12-2, 12-3, 12-5
- Scroll, alarm message screen, 6-12
- Scrolling, 3-10
- Sections of a screen, 4-1
- Securing, TP, 12-5
- Select
  - printer, 7-3
  - record set, 8-15
  - screen, 4-2
  - value, 3-10
- Self test, 13-8
- Serial download, 13-4
- Serial interfaces, 14-2, 15-3, 16-5
- Serial printer connection, 12-12
- Serious system message, 6-8
- Service life
  - back-lighting, 18-4
  - backup battery, 18-2
- Set
  - acknowledgment group, 6-27
  - date, 6-27
  - date/time, 11-8
  - language, 11-8
  - message display, 6-28
  - message event, 6-27
  - operating mode, 11-4
  - output medium, 6-27
  - printer colors, 7-4
  - printer interface, 7-3
  - priority, 6-27
  - text, 6-27
- Set up, data areas, 1-2
- Settings
  - ASCII character set, 12-12
  - printer, 7-2, 12-12
  - startup phase, 9-3
  - system, 6-28
- Shift, 3-9
- Shipping conditions, A-3
- Shock loading, A-3
- Side view
  - TP27-10, 15-2
  - TP27-6, 14-1
  - TP37, 16-2
- Sign, changing, 3-7
- Signal tone, 3-4, 13-2
  - adjusting volume, 11-8
- Significance, messages, 6-10
- SIMATIC 500/505, 2-4
  - connection, 14-3, 15-4, 16-6
- SIMATIC HMI documentation, D-1
- SIMATIC M7, connection, 14-3, 15-4, 16-6
- SIMATIC S5, connection, 14-3, 15-4, 16-6
- SIMATIC S7, connection, 14-3, 15-4, 16-6
- Sort order, messages, 6-11
- Source of supply, backup battery, 18-2
- Spare parts service, 18-2
- SRAM, A-1
- SS number, printer, 7-3
- Standard configuration, 4-3
- Standard screen
  - Backup/Restore, 9-5
  - Data Record Processing and Transmission, 8-4, 8-6
  - Edit Message, 6-15, 6-24
  - Edit Password, 5-2
  - Force Variable, 10-5
  - Output Messages, 6-26
  - Printer Settings, 7-2
  - Status Variable, 10-2
  - System Settings, 6-11, 6-28, 11-2
- Standard screens, 4-3
- Standby message, 6-3
- Startup behavior, 13-8
- Startup phase, 9-3
- Static discharge, A-4
- Status, message, 6-1
- Status disturbance, reporting, 6-2
- Status Variable, 10-1, 10-2
  - control sequence, 10-4
- Stop bits, printer, 7-3
- Storage, A-3
- Storage medium, 9-1
- Store
  - data, 9-1
  - data record, 8-11
- Structure
  - alarm message, 6-4
  - alarm message screen, 6-12
  - message buffer, 6-13
  - message page, 6-11
  - standard screen
    - Backup/Restore, 9-5
    - Data Record Processing and Transmission, 8-4, 8-6
    - Edit Message, 6-24, 6-26
    - Printer Settings, 7-2
    - System Settings, 6-28, 11-2
  - system message, 6-8
  - user interface, 1-4
- Structure of the documentation, D-1
- Sub-D socket, B-1, B-2
- Summer and winter time, 11-8
- Sunlight, 12-1

Superuser, 5-1  
Supervisor, 5-1  
    password change, 5-6  
Switch, IF1B interface, 12-11  
Switch off, acoustic signal, 11-8  
Switch on, acoustic signal, 11-9  
Switching power, relay contacts, A-2  
Switchover, keyboard , 3-9  
Symbol  
    hand, 3-5  
    message indicator, 6-6  
Symbol lists, 1-3  
Symbolic name, recipe, 8-2  
Symbolic value entry, 3-10  
System message, 6-8  
System message window, 6-8  
System messages, list of, C-1  
System Settings, standard screen, 6-11, 6-28,  
    11-2

## T

Target groups, D-1  
Technical data  
    TP27, A-1  
    TP37, A-1  
Temperature limit value, 1-5  
Temperature monitoring, 12-8  
    relay output, 16-5  
Temperature variation, display, 1-3  
Terminal block, 12-8  
Test, configuration, 13-9, 13-10  
Text, set, 6-27  
Text attributes, 2-2  
Text list, 3-10  
Texts, 1-4  
Time  
    message, 6-4  
    message event, 6-9  
Time/date, setting, 11-8  
Timeout, printer, 7-3  
Touch, button, 3-4  
Touch element  
    definition, 3-4  
    operating, 3-4  
Touch panel, operating, 1-1  
Touch screen, 1-1, 14-2, 15-3, 16-3  
    calibrating, 11-7  
    deactivate, 11-6  
Touch-sensitive button, 1-4  
TP start-up, 13-2

TP27-10, installation, 12-3  
TP27-6, installation, 12-2  
TP37, installing, 12-5  
Transfer, data record, 8-13  
Transfer parameters, printer, 7-3  
Transients, A-2  
Trends, 1-3  
Trigger, function, 3-4  
TTL connection, 16-6  
TTY connection, 14-3, 15-4, 16-6  
Type, printer, 7-3  
Types of downloading, 13-4  
Types of message, 6-2

## U

UL certification, A-4  
Unit description, 14-1, 15-1, 16-1  
Unit dimensions  
    TP27-10, 15-2  
    TP27-6, 14-1  
    TP37, 16-2  
Update, data record, 8-13  
Updating, ALARM\_S Messages, 6-22  
Upkeep, 18-1  
Use, 1-1  
Use of resources, ALARM\_S Messages, 6-18  
User group, 5-1  
User interface, structure, 1-4

## V

Value  
    entering, 3-6  
    select, 3-10  
Ventilation slits, 12-1  
Vibration, A-3  
View, password list, 5-7  
Virtual keys, 3-1  
Visual acknowledgement, 3-4, 3-5  
Visualize  
    process, 1-3  
    process variables, 1-1  
Voltage, backup battery, A-2

## W

Weight, A-1  
Window, messages, 6-3  
Window positions, 3-3