

SITOP
power DC-UPS Module 40

6EP1931-2FC01

1	2	3	4	5	6
---	---	---	---	---	---

Operating Instructions

Order No. 814692-5 Bs 4

Dimensional drawing

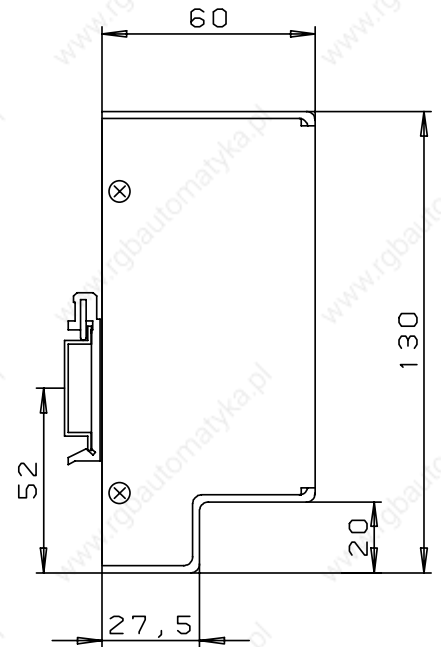
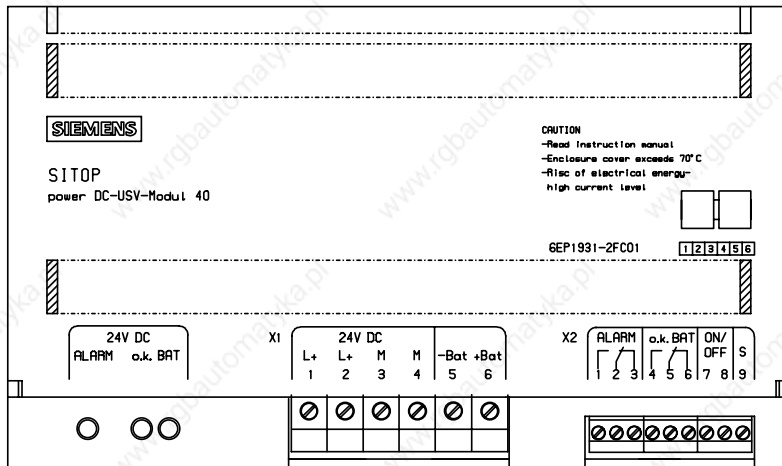
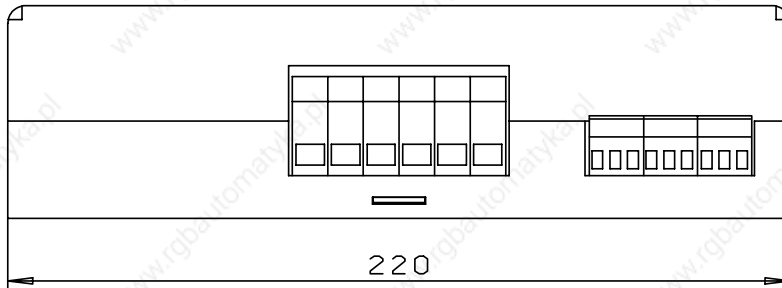

Mounting

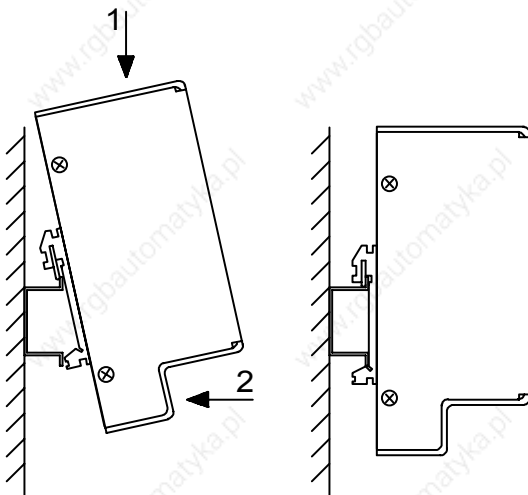

Dismounting

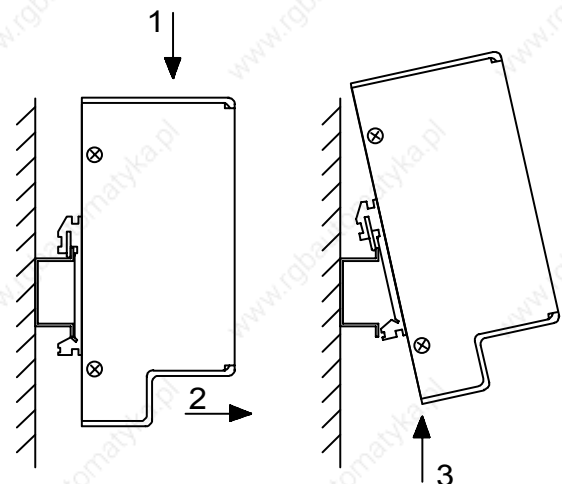

Block diagram

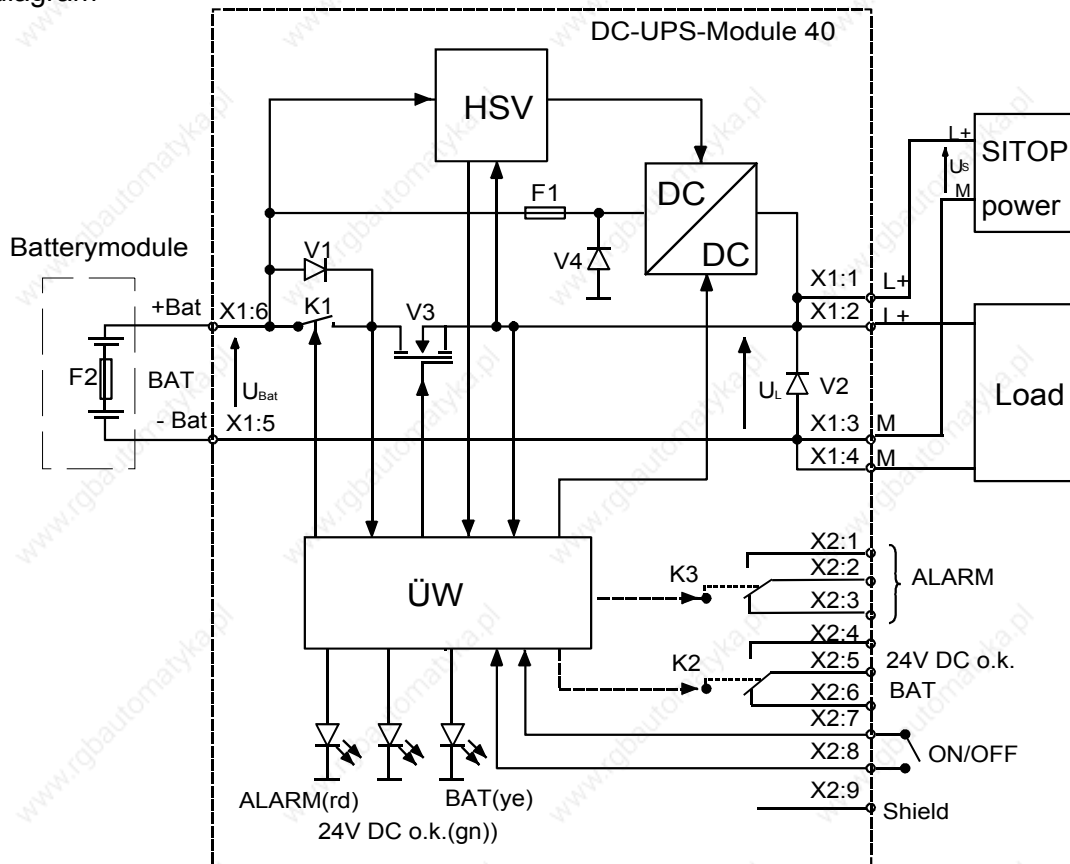

Warning Notes

The DC UPS Module 40 is a rail-mounted unit for use in industry in combination with the three-phase power supplies SITOP power 10A/ 20A/ 30A/ 40A.

The use in residential and commercial environments as well as light industry is permissible in combination with the single-phase power supply SITOP power universal line 20A.

Only appropriately qualified personnel should be allowed to operate this device or work in its vicinity.

It is assumed that this product be transported, stored and installed as intended to ensure that product functions correctly and safely.

The device may not be opened.

In operation and especially in the case of short circuit, very high transient current may occur. On delivery, the buffer batteries are fully charged.

Make sure that the batteries do not get in contact with oil or organic detergents.

The connection lines are supplied in the max. admissible length.

Generally, the following instructions must be complied with:

- Operating Instructions DC-UPS Module 40
- Operating Instructions SITOP power
- any warning notes affixed on the individual components

CAUTION: Improper use of the DC-UPS Module 40 and the connected components can result in serious damage to equipment.

DC-UPS Module 40

Field of application: - output voltage buffering of power supplies SITOP power by a 24 V battery (maintenance-free lead accumulators) used as energy store in case of mains failure or overload

Design: - rail-mounted unit designed for installation on a carrier rail 35 x 15 or 35 x 7,5 acc. to EN 50022
- connection of supply and signal lines in fitting position from bottom by screw terminals
- signalling of operating conditions by three LEDs
- output of current operating mode „Mains/battery“ as well as „Ready to buffer/alarm“ via a potential-free change-over contact

Weight: - approx. 1.2 kg

Buffer principle: - see Block diagramm

Mains operation: - SITOP power supplies load
- $23.5\text{ V} \leq U_L \leq 26\text{ V}$
- battery is loaded through DC/DC and maintained at 27.3 V

Overload with mains operation: - $U_L < 22.5\text{ V}$
- V_3 switches battery to load via K_1
- after then, V_3 turns off for detecting end of overload (measuring gap)
- if during the measuring gap $U_L > 22.5\text{ V}$, V_3 will switch off again

Short mains failure: - $U_L < 22.5\text{ V}$
- V_3 switches battery to load
- after then, cyclic measuring gap to detect restart of SITOP Power
- in case of restart, during one of the following measuring gaps, SITOP Power provides load current
- if during the measuring gap $U_1 > 22.5\text{ V}$, V_3 will switch off again



NOTES: - When using modules 3AC 400V-SITOP power 30A/ 40A and load currents of $< 15\text{ A}$ occur, depending on U_s and the charging condition of the battery mains power return and providing of the load current by SITOP power might be delayed.
- When using a 3AC 500V-SITOP power 10A or 20A Power Module, a minimal load current $I_L \geq 1,5\text{A}$ is necessary.

Total mains failure: - $U_L < 22.5\text{ V}$
- V_3 switches battery to load
- after then, cyclic measuring gap
- from $U_{\text{Bat}} \leq 22,5\text{ V}$: V_3 permanently on
- from $U_L \leq 20.4\text{ V}$: ALARM LED On
- when $U_{\text{Bat}} < 18.5\text{ V}$ (total discharge threshold), disconnecting the battery from load by V_3 and monitoring unit ÜW will turn off the UPS

- Mounting/ Dismounting:
- see Figure
 - clearances to be provided when the module is installed:
 - 30 mm to the right and to the left
 - 80 mm beneath and above

Buffer Battery

- when using the product in combination with SITOP power 10A/ 20A, two maintenance-free lead accumulators 12 V/ 7Ah YUASA NP7-12L must be used in series connection
- installed and wired together with the fuse holder in the battery receptacle (battery module)
- weight of battery module: approx. 6 kg
- fuse cartridge: FK2 flat fuse 25A Pudenz

 Install the fuse only during commissioning. 

- When using the product in combination with SITOP power 30A/ 40A, two battery modules must be connected parallel

- Installation:
- Installation place: in the lower part of the control cabinet
 - Assembly position: vertical (battery poles below, cable inputs top)
 - Mounting: 4 screws M4

-  **Warning Note:**

The adjusted value of 27.3V for the end-of-charging voltage is applicable to a battery temperature ranging from +5°C to +40°C during operation. When the temperature is below +5°C, the battery cannot be fully charged. Temperatures of more than +40°C will reduce the life of the battery and can destroy it.

Storage, assembly and operation of the buffer battery must be performed acc. to the VDE 0510 standard and, resp., the relevant national regulations. Sufficient aeration and deaeration of the battery location must be provided. The user is required to recycle defective batteries acc. to the environmental regulations.

Installing the Components

(only by qualified personnel)

-  **Warning Note:**

Prior to any installation or maintenance work, the master circuit breaker of the SITOP power must be turned off and secured against re-energizing. A battery fuse that has already been inserted must be removed.

- Install the SITOP power as described in the Operating Instructions.
- Connect the output terminals L+ and M, resp., of SITOP power with one of the respective terminals of the DC-UPS Module. (X1:1; X1:3)
 - Line length: ≤ 0.5 m
 - Cross section: SITOP power 10A/ 20 A ≥ 4 mm²

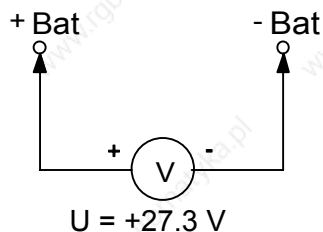

- Checking the battery terminals for pole reversal: - by voltmeter on the contacts of each battery fuse holder

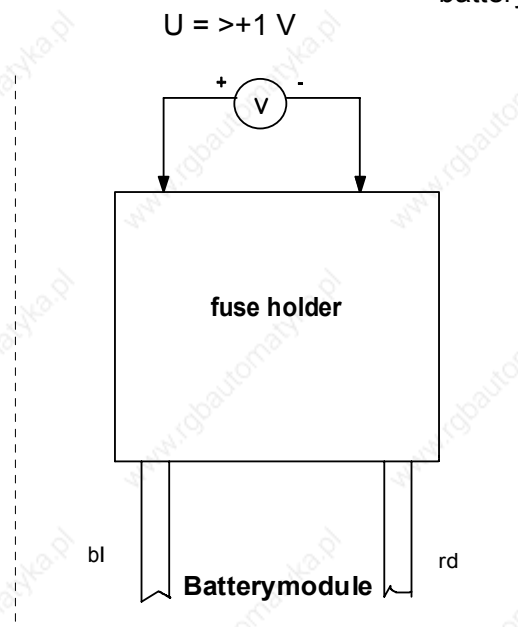

- when negative voltages occur: - SITOP master circuit breaker OFF
- Check wiring.
- otherwise: SITOP master circuit breaker OFF
- Insert the fuse cartridge.
- Put the cover to the battery fuse holder.

-  **Warning Note:**

When the battery fuse is installed despite reversed battery terminals, sparks occur at the fuse holder.
At the same time, fuse F1 in the DC-UPS module (no access from outside) responds.

- Connect the external NO contact with the On/Off terminals of the DC-UPS module.

Line length: ≤ 3 m
Cross section: ≤ 2.5 mm²

If a line length of > 3 m is required and the output voltage of SITOP power is operated potential-free, the S terminal of the DC-UPS module must be connected with PE (carrier rail).
(see Technical Data, EMC).

Line length: ≤ 0.15 m
Cross section: $= 2.5$ mm²

- SITOP power master circuit breaker ON.
- Approx. 2 sec. after starting up SITOP power, the DC-UPS module is ready for operation.
- LED „24V DC o.k.“ (green) lights.
- After changing the battery, the approach is the same as with „Commissioning“.

Technical Data

(applicable to the DC-UPS module 40 in conjunction with SITOP power and the attached battery module)

- Standards:
 - class of protection III acc. to EN 60950
(The natural potential equalization through mounting is admitted.)
 - degree of protection IP20 acc. to DIN VDE 0470, 11/92
 - safety SELV acc. to EN 60950

- Environment:

	<u>DC-UPS module 40</u>	<u>Buffer battery</u>
- Temperature Storage and transport:	-25°C ... +85°C	-20°C ... +50°C
- Operation:	0°C ... +60°C	+5°C ... +40°C
- Humidity class:	F acc. to DIN 40040	
	i.e.: <ul style="list-style-type: none"> - relative humidity $\leq 75\%$ (average humidity) - relative humidity on 30 days over the year = 95% (in a natural way distributed over the year), on the remaining days sometimes 85% (in the range of the annual average) - no moisture condensation 	
- Cooling:	convection	

- Input variables mains operation:
 - Supply by SITOP power
 $U_S = 24V$ (23,5...26V) DC, SELV
 $I_S = 10A/ 20A/ 30A/ 40A$ (incl. 3A for battery charging)

- Input variables battery operation:
 - Supply by buffer battery

$$U_{\text{Bat}} = 24\text{V (27,3...18,5V) DC}$$

$$I_{\text{Bat}} = 20\text{A/ 40A}$$

- Input signal ON/ OFF:
 - making/cancelling readiness to buffer with mains operation
 - switching off the battery with battery operation
 - external N. O. contact, potential-free
 - load: $U_{\text{max}} = 12\text{V DC, SELV}$
 $I_{\text{max}} = 5\text{mA}$

NOTE: Connecting the battery with $U_{\text{S}} = 0\text{V}$ via the signal ON/OFF is not possible.
First, the condition $U_{\text{S}} \geq 15\text{V}$ for $t = 2\text{s}$ must be met.

- Shield connection S:
 - to be connected with PE to increase noise immunity (see „Installation“ and „Technical Data/EMC“)
- Output variables mains operation:
 - $U_{\text{L}} = U_{\text{S}}$
 - $I_{\text{L}} = I_{\text{S}} - 3\text{A (typ.)}$

- Output characteristic of charge controller:

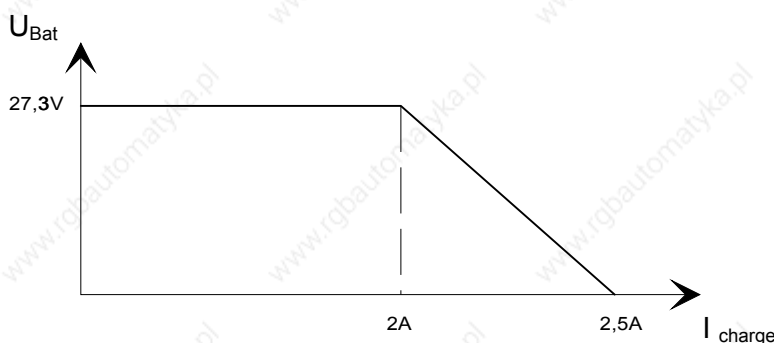

- Output variables battery operation:
 - $U_{\text{L}} = U_{\text{Bat}}$
 - $I_{\text{L}} = I_{\text{Bat}}$

- ripple U_{L} with battery operation:

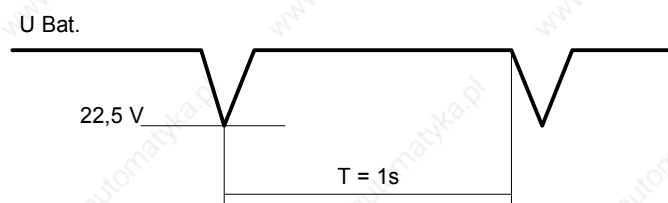

- current limitation with battery operation

- short circuit on output:
 - $I_{\text{L short}}$ limited by power circuit breaker to approx.. 120 A
 - disconnection of $I_{\text{L short}}$ after 12 ms (standard value) by the temperature control of the power circuit breaker.

- dynamic overload:
 - $I_L \text{ nom} < I_l \text{ dyn} < I_L \text{ short}$
 - disconnection of I_{out} only when the temperature control in the power circuit breaker responds.
- static overload:
 - $I_L \text{ nom} < I_L < I_L \text{ short}$
 - disconnection of I_{out} only when the temperature control in the power circuit breaker responds.

NOTE : After the power breaker has been cooled down, the temperature control will be reset.

- buffer time: t_b c. 5 min (discharge of the supplied buffer battery, fully-charged, with $I_{L \text{ nom}} = 20A/ 40A$ down to $U_L = 20.4V$)

- Output signals: - Signal output via potential-free changeover contacts

<u>Name</u>	<u>Indication</u>	<u>Output</u>	<u>Meaning</u>
mains operation	LED „24V DC o.k.“, gn		-SITOP power active, battery is being loaded
battery operation (= neutral position of contacts)	LED „BAT“, yellow		- SITOP power out of operation, or overload, load is (additionally) supplied from battery
no readiness to buffer (= neutral position of contacts)	LED „ALARM“, red		<ul style="list-style-type: none"> - reversal of battery poles - input signal ON/ OFF inactive - $U_L < 20.4V$ with battery operation - $U_{\text{Bat}} < 24V$ with mains operation when $U_L < 20.4V$ with battery operation - turn-on RESET
	LED „ALARM“, red is blinking		- battery circuit disconnected

- load capacity of the contacts: $U_{\text{max}} = 42,4V \text{ AC (peak value) / } 60V \text{ DC, SELV}$
 $I_{\text{max}} = 1 \text{ A}$

- EMC: Test with the max. admissible length of connection lines and a low-impedance connection from carrier rail 35 x 15 to PE

- Noise emission: EN 50081-1 / 1992
Limit line B acc. to EN 55022

- Noise immunity: EN 50082-2 / 1995

- Housing:
 - ENV 50140
10V/m, 80-1000MHz, 80%AM
 - ENV 50204
10V/m, 900MHz, 50%PM
 - EN 61000-4-2
4kV contact discharge
8kV air discharge

- Terminals L+/M: X1:1; X1:3
 - ENV 50141
10V, 0,15-80MHz, 80%AM
 - EN 61000-4-4
2KV
 - EN 61000-4-5
1kV symm.
0,5kV asymm. (M potential-free and terminal S open)
2kV asymm. (M or terminal S connected to PE)

- Terminals +Bat/ -Bat: X1:6; X1:5
 - ENV 50141
10V, 0,15-80MHz, 80%AM

- Terminals 24V DC o.k./BAT, ALARM: X2:4,5,6; X2:1,2,3
 - ENV 50141
10V, 0,15-80MHz, 80%AM
 - EN 61000-4-4
1kV

- Terminal ON/ OFF: X2:7,8
 - ENV 50141
10V, 0,15-80MHz, 80%AM
 - EN 61000-4-4
2kV
 - EN 61000-4-5
1kV symm.
0,5kV asymm. (M potential-free and terminal S open)
2kV asymm. (M or terminal S connected to PE)