



sinudyn-36

Hardware Description

Rack Design

SIEB & MEYER AG

Auf dem Schmaarkamp 21 ★ D-21339 Lüneburg ★ Germany

Telephone: ++4131/203-0 ★ Telefax: ++4131/38562

Email: documentation@sieb-meyer.de

Internet: www.sieb-meyer.de

The text and the translation of the manual have been worked out very carefully.
However, SIEB & MEYER AG can accept neither obligation nor legal responsibility
for incorrect specifications and their consequences,
possibly still described in the manual.

Subject to technical alterations!
©SIEB & MEYER AG, Lüneburg
036-servo-tec-sinudyn36/R004-sm-en-hp/hk/ca/ac/sü
February 17, 2002



1	Used Symbols and Abbreviations	7
1.1	Measuring Units	7
1.2	Symbols	7
1.3	Abbreviations	8
1.4	Product Designations	8
2	About this Manual	9
3	Safety Instruction and Application Advice	11
3.1	General Information	11
3.2	Appropriate Use	11
3.3	Transport and Storage	12
3.4	Installation	13
3.5	Electrical Connection	13
3.6	Operation	14
3.7	Maintenance	14
3.8	Guarantee	14
4	Unit Assembly Complying EMC	15
5	Specific Safety Information	17
5.1	Mains Filters	17
5.2	Safeguard (Preventing an Unintentional Start)	17
6	Digital Servo Amplifier <i>sinudyn-36</i>	19
6.1	Block Diagram	21
6.2	Standard Configuration of <i>sinudyn-36</i>	22
6.3	Module Designation	24
7	Technical Data	25
7.1	Multi-Axis Servo Modules of Series <i>sinudyn-36</i>	25
7.1.1	Intermediate Circuit Voltage 48 V _{DC} up to 325 V _{DC}	25
7.1.2	Intermediate Circuit Voltage up to 680 V _{DC}	25
7.2	Compact Amplifiers of Series <i>sinudyn-36</i>	26
7.2.1	Intermediate Circuit Voltage 48 V _{DC} up to 325 V _{DC}	26
7.2.2	Intermediate Circuit Voltage 48 V _{DC} up to 680 V _{DC}	27
7.2.3	Protection of the Compact Amplifiers 36.03.xx	27
7.3	Power Modules 26.50.65 and 26.50.88	28
7.4	Chassis	29
7.4.1	Design of the Multi-Axis Chassis, 6 HU	29
7.4.2	Design of the Multi-Axis Chassis, 3 HU	30
8	Dimensioned Drawings	31
8.1	6 HU Chassis for Wall Mounting (Compact Amplifier)	31
8.2	6 HU Chassis for Hinged Frame Mounting	32
8.3	3 HU Chassis for Hinged Frame Mounting	32
9	Mechanical Mounting	35
9.1	Back Plane Fixing	36
9.2	Replacement of Servo Modules	37
10	General Information Regarding the Wiring	39
10.1	Motor Cables	40
10.2	Shield Bars for Cables for Rotary Encoders	41
10.3	Wiring of the Analog Ref. Values	41
10.4	Wiring of the Angle Pulses	42
11	Back Planes	43
11.1	Back Plane 36.01.0041.2	43
11.2	Back Plane 36.01.0046	44
11.3	Back Plane 36.01.0042.1	45
11.4	Back Plane 36.01.0043.1	46
11.5	Back Plane 36.01.0044.1	47



12	Pin Assignment and Interfaces	49
12.1	X1 - Connection of the Motor Measuring System	49
12.2	X2 - Analog Signals	52
12.3	X3 - Digital Inputs and Outputs	53
12.3.1	15-Pole Male Submin D Connector	53
12.3.2	15-Pole PHOENIX Mini CombiCon	53
12.4	X4 - Angle Pulses	55
12.5	X5 - Thermal Motor Protection	56
12.6	X6 - Safeguard (Preventing Unintentional Starts)	57
12.7	X7 - Transducer	58
12.8	X8 - COM 1	58
12.9	X60 - Power Bus	59
12.10	S1 - ID-coding selector	59
12.11	U / V / W - Motor Connections	60
12.12	L1, L2, L3 - Mains Input for the Main Supply	60
12.13	+24 V - Logic Supply	60
12.14	LL1, LL2 - Eingänge für die Logikeinspeisung	61
12.15	Earth Conductor	61
12.16	R _{EX} - External Ballast Resistor	61
13	Digital Inputs and Outputs	63
13.1	Specification of the Inputs and Outputs	63
13.1.1	Inputs	63
	Operational Mode: Nut Setting	63
	Operational Mode: Servo	64
13.1.2	Outputs	64
	Operational Mode: Nut Setting	65
	Operational Mode: Servo	66
14	Safeguard (Preventing Unintentional Start)	67
14.1	Safeguard Function	67
14.2	Exemplary Wiring	69
15	Front Panel	71
15.1	Multi-Axis Servo Amplifier	71
15.2	Compact Amplifiers	72
15.3	Test Pins	73
15.4	Indication of the Front Panels	74
15.4.1	Status Indication <i>RON</i>	74
15.4.2	Status Indication <i>RIO</i>	74
15.4.3	Status Indication <i>H0/H1</i>	74
15.4.4	Messages	74
15.4.5	Error Messages	75
16	Layout Plans	77
16.1	Layout Plan of the logic 36.01.0021.3	77
16.2	Compact Power Module for the Servo Amplifiers 36.03.10 and 36.03.11	78
16.3	Compact Power Module for the servo amplifiers 36.03.13 and 36.03.14	79
	Appendix	81
17	Electric Performance Dimensioning	81
17.1	Components	81
17.1.1	Output Stage	81
	Voltage Range	81
	Current Range	81
17.1.2	Power Supply	81
	Voltage Range	81
	Current Range	82
	Capacity	82
17.1.3	Motor	82



	Peak Current	82
	Rated Current	82
	Voltage Constant	83
	Torque Constant	83
	Inductive Coil Resistance	83
	Ohmic Coil Resistance	83
	Electric Time Constant	83
	Nut Setting Motors	83
17.2	Power Consumption of a Drive	84
18	Appendix: Revisions	85



1 Used Symbols and Abbreviations







1.1 Measuring Units

The dimensions of the products by SIEB & MEYER AG are indicated in HU and WU.

Abbreviation	Meaning	
HU	technical unit for the height	1 HU $\hat{=}$ 44.45 mm / 1.75 inches
WU	technical unit for the width	1 WU $\hat{=}$ 5.08 mm / 0.2 inches

1.2 Symbols

In the following table the symbols used in this manual for describing purposes are explained. Technical symbols and signs are supposed to be known and therefore not explained.

Symbol	Meaning	
	Warning: information for avoiding damages to man and machine.	
	This symbol indicates dangerous contacts.	
	This symbol indicates currents and voltages.	
	This symbol indicates general notes.	
	LEDs for indicating the module status	LED on
		LED off
		LED flashes



1.3 Abbreviations

General abbreviations

CE	CE -labelling (Communauté Européenne = European Community); confirms the conformity of products with the relevant EU standards and guidelines
DIN	Deutsches Institut für Normung = German Institute for Standards
EMV	Electromagnetic compatibility = EMC
EN	European standard
IEC	International Electrotechnical Commission
VDE	Verband Deutscher Elektrotechniker = Association of German Electricians
LED	Light Emitting Diode
NTC	negative temperature coefficient
PTC	positive temperature coefficient
V_{AC}	Alternating current
V_{DC}	Direct current

Physical connections

Physical connections are designed according to the type of wiring with the following abbreviations:

I	input
O	output
n.c.	not connected

1.4 Product Designations

Product names mentioned in this documentation are trademarks or registered trademarks of their respective companies.

The appropriate name of the company is characterized by CAPITAL LETTERS.

Examples:

- ▶ SIEB & MEYER power module 26.44.59
- ▶ PHOENIX terminal
- ▶ measuring system by HEIDENHAIN

2 About this Manual

This manual describes the digital servo amplifiers of the series *sinudyn-36* (standard design). The following information is provided:

- ▶ Safety and application advice
- ▶ Unit assembly according to EMC
- ▶ Technical data, dimensioned drawings, name plate
- ▶ Amplifier description (general information, scope of supply, block diagram)
- ▶ Mounting (fixing of the back planes, replacement of modules)
- ▶ General information regarding the wiring (cables and conductor cross-sections)
- ▶ External protection, ballast circuitry
- ▶ Wiring examples
- ▶ Back planes and pin assignment
- ▶ Status and error messages

Information about the initial setup and the parameterization of the digital servo amplifier can be found in the manual "*sinudyn-36* - Software Description".

This manual is available in German and English as printed manual and in the internet as PDF file. The PDF files can be downloaded and printed on customary printers.

The manual has the following demands on the trained staff of machine manufacturers:

	Transport	→ only by skilled employees familiar with handling electrostatically sensitive components
	Installation	→ only by experts with electrotechnical experience
	Initial operation	→ only by experts with experience in the fields of electrical engineering / drive technology



3 Safety Instruction and Application Advice

According to **Low-Voltage Guideline 73/231/EEC**
Machine Guideline 89/392/EEC
Electromagnetic Compatibility 89/336/EEC

3.1 General Information



In principle, the complete installation, the initial operation and the maintenance must only be carried out by trained staff.

Trained staff according to this fundamental safety instruction are persons familiar with the installation, mounting, initial and permanent operation of the product, and which are appropriately qualified for the work. The standards *DIN VDE 0100* and *DIN VDE 0110* and also the legal *national rules for prevention of accidents* must be paid attention to.



During the operation the units can have *energized* and *hot surfaces* according to their protection system.



Subjects can be damaged and persons be injured

- ▶ when covers are removed illegally,
- ▶ during any improper use,
- ▶ when either the installation or the operation is incorrect.



Consult **SIEB & MEYER** before carrying out any modifications within the unit.

3.2 Appropriate Use

Since the products of SIEB & MEYER are electronic equipment used for the operation of motors and provided for the installation into machines the safety considerations of the *Machine Guidelines (89/392/EEC)* must be paid attention to.

Before initial operation, make sure that the machine will not expose danger (e.g. runaway moves). The conformity according to the *Guideline EN 60204-1 / IEC 204-1* must have been proven.

The manufacturer of the system or the machine has to meet the requirements of the legal values regarding the *Electromagnetic Compatibility (EMC)*. SIEB & MEYER's units can be operated in industrial areas, provided the attached EMC information has been taken into consideration.

SIEB & MEYER takes care in its own EMC laboratory over their products to meet the respective standards, when they are installed properly.

Deviations of the construction and the installation, described in the documentation and in the manual "Unit Assembly Complying EMC" require new measurements of the system or machine by the machine manufacturer to meet the statutory requirements.

Appropriate proceedings according to the *EMC Product Standard (PDS) DIN/EN 61 800-3/IEC 1800-3* ensure the use in industrial areas.

- ▶ Products, not equipped with an *AC supply line filter* must be operated with a series connected *mains filter*.
 - Servo amplifiers: SIEB & MEYER mains filter of series 011.00.3x
 - Converters: SIEB & MEYER mains filter of series 011.00.7x
- ▶ Servo amplifiers without *motor filters* need the motor lines to be looped at least *3-times through a ferrite core*.
- ▶ All SIEB & MEYER frequency converters are equipped with *motor filters* in the factory.

If using the drive systems in residential areas, in business and commercial areas as well as in small trade, the user has to take additional and larger filter measurements.

SIEB & MEYER products meet the requirements of the *Low-Voltage Guideline 73/231/EEC*. The coordinated standards of the series *DIN EN 60 204 / IEC 204* in combination with *DIN EN 60 439-1 / IEC 439-1* and *DIN EN 60 947 / IEC 947* are strictly used for the products.

The drive systems must only be driven in enclosed switch cabinets, offering at least the degree of protection IP54 and under the environmental conditions, specified in section 3.4.

Technical data and the connection specification can be found in the respective product documents.

3.3 Transport and Storage

Make sure, that the unit is correctly used. The following points must especially be taken into consideration:

- ▶ Protection against mechanical damage (transport, handling, etc.)!
- ▶ Protection against dirt and humidity!
- ▶ Dry and well-ventilated storage area!
- ▶ No storage in the open!
- ▶ Storage temperature between -25°C to $+55^{\circ}\text{C}$ (-13°F to $+131^{\circ}\text{F}$)! Shortly it may be $+70^{\circ}\text{C}$ ($+158^{\circ}\text{F}$).
- ▶ Protection against contact with electronic components (electrostatic discharge)!
- ▶ No modification of insulating distances!

3.4 Installation

- ▶ The units can be loaded to their maximum up to a height of 1,000 m M.S.L. (3,281 ft M.S.L.)
- ▶ For an operation in areas higher than 1,000 m M.S.L. (3,281 ft M.S.L.) the capacity must be reduced by 15 % per 1,000 m (3,281 ft.)
- ▶ The ambient air must not contain aggressive, electrically conductive or flammable substances and should contain minimum amounts of dust.
- ▶ The maximum relative humidity is approx. 95 % (no condensation).
- ▶ The admissible ambient temperature during the operation is between +5°C and +40°C (+41°F and +104°F).
- ▶ At temperatures higher than 40°C (104°F) the capacity must be reduced by - 1.5 % per 1°C. *Annotation: $F = C \times 9/5 + 32$; $C = (F - 32) \times 5/9$*
- ▶ Make sure that the fans installed in the units have sufficient space to take in and exhaust the cooling air!
- ▶ Do not touch electronic components.



SIEB & MEYER products contain electrostatically sensitive components that may easily be damaged by improper handling.

3.5 Electrical Connection



The valid rules for prevention of accidents (e.g. VBG 1 and VBG 4) should be paid attention to, when working at current-carrying units.

The electrical installation must be carried out according to the relevant electrical codes (e.g. appropriate wire gauges, fuse protection and connections of ground conductors must be considered).

Recommendations for the installation according to the EMC (e.g. shields, connection to earth and line installations) can be found in the technical documents of the unit (only for machine manufacturers). The manufacturer of the system or machine has to meet the requirements of the legislation regarding the EMC.

- ▶ All work at and within the units must only be carried out, when they are turned off and when the AC line is cut!
- ▶ The mains line should only be connected, when the work is completed!
- ▶ Before turning on the unit the first time, make sure that the connected machine will not have runaway axes!
- ▶ After turning off the unit hazardous voltages may still exist for up to **3 minutes** in the power supply (due to capacitors).
- ▶ Capacitive loads must not be connected to the output phases of the servo amplifiers and frequency converters.
- ▶ Prevent cable loops. Therefore, the units must **only** be connected to earth at the provided earth connection \perp for the mains supply line and the racks **only** at the provided earth screw.

In general, the operation can be made with residual current operated devices. Nevertheless, like all clocked units of the power electronics, also SIEB & MEYER's products can lead leakage currents via the earth system. Depending on the sensitivity of the residual current operated device and the installation type, the operation along with the device may arise problems. The following points should be taken into consideration:

- ▶ Use shortest motor leads possible.
- ▶ Do not connect additional consumers to the same residual current operated device.
- ▶ Use a residual current operated device with high response threshold.

3.6 Operation

Systems, into which servo amplifiers and frequency converters are mounted, possibly must be equipped with additional protective devices according to the valid safety instructions (e.g. law about technical material, rules for prevention of accidents, etc.).

All doors and covers must be closed during the operation.

3.7 Maintenance

The unit, especially the fan, must be checked regularly for cleanness and function depending on the ambient pollution.

3.8 Guarantee

The guarantee is only granted when the points 3.1 to 3.7 are taken into consideration.

This Safety Instruction and Application Advice does not assure any features.



A first programming carried out by SIEB & MEYER does not release the user from his duty to check programmed values for their correctness!

SIEB & MEYER AG

October 25, 2001

Save these Safety Instructions!

4 Unit Assembly Complying EMC



The EC guidelines for the electromagnetic compatibility (EMC) must be taken into consideration for the initial operation of all SIEB & MEYER units!

The manual "Unit Assembly Complying EMC" is available in German and English and comprises

- ▶ the EMC guidelines
- ▶ Information regarding the professional earth and wiring
- ▶ Safety-relevant aspects
- ▶ Extracts from the EMC product standard

Availability:

- ▶ Hard copy version directly from SIEB & MEYER
- ▶ PDF file in the Internet under www.sieb-meyer.de



5 Specific Safety Information

5.1 Mains Filters

The following mains filters should be used for the operation of the *sinudyn-36* compact amplifiers:

	S&M Mains Filter
1-phase power supply up to 25 A rated current in intermediate circuit	011.00.11A/18
3-phase power supply up to 30 A rated current in intermediate circuit	011.00.73C/D
3-phase power supply up to 62 A rated current in intermediate circuit	011.00.80

The specifications apply for 8 kHz PWM of the output stage.

The compact modules 36.05.xx are equipped with mains input filters.

A ferrite core R27 ws with 5-fold winding must additionally be put over the motor leads at the amplifiers 36.04.xx with 3 HU.

5.2 Safeguard (Preventing an Unintentional Start)

✘ according to EN 945-1 category 3

The safeguard is exceptionally provided to prevent an **unintentional restart** of a drive. To achieve a safe protection against the restart, the safety requirements of DIN/EN 60 204-1 *Electrical equipment of machines*, of DIN/EN 61 800-2 *Speed-variable electrical drives* and the actual VBG 4 § 4 and § - *Accident prevention regulations* must be taken into consideration for the circuitry and wiring of the safety circuit.

The safeguard must only be activated, if

- ▶ the motor is at standstill (reference value = 0 V, speed = 0 RPM)
Drives with hanging load must additionally be blocked mechanically, e.g. with a holding brake.
- ▶ the monitoring contacts of all servo amplifiers are connected to the control circuit of the CNC (identification of broken lines).

The safeguard must only be activated by the CNC / controller, if the activation of the internal safety relay is monitored redundantly.

If the drive is to be stopped for one of the following reasons, the safeguard **must not** be used according DIN/EN 60 204-1 *Electrical equipment of machines*:

- ▶ Cleaning, maintenance and servicing work
- ▶ Long interruptions of operation

Then the complete system must be dead (main switch/emergency stop). The safeguard, however, just enables the function “safe stop”. It must never replace the function “standstill in case of emergency”.



The functions “safe stop” and “setting-up operation” are no safety functions in the sense of the machine guideline 89/392/EWG. They only support the measures to be taken by the user.

6 Digital Servo Amplifier *sinudyn-36*

Suitable for the Following Motor Types

- ▶ Synchronous rotatory AC servo motors
 - with integrated resolver,
 - with Hall effect sensors or
 - with high-resolution sine-cosine encoder as motor measuring system
- ▶ Synchronous AC linear motors with high-resolution sine-cosine encoder as motor measuring system.

Design

- ▶ 3 HU compact amplifier in rack design
- ▶ 6 HU compact amplifier in rack design
- ▶ 6 HU multi-axis amplifier in rack design
- ▶ Compact amplifier in front connection design, see “*sinudyn-36* Hardware Description 36.05.xx Front Connection Design”

Performance Ranges



The mentioned currents are peak currents (sine crest values).

- ▶ 3 HU servo amplifiers (20 A, 30 A) up to an intermediate circuit voltage of 325 V_{DC}
- ▶ 6 HU multi-axis servo amplifiers (20 A, 40 A, 60 A, 80 A, 100 A) up to an intermediate circuit voltage of 325 V_{DC}
- ▶ 6 HU compact amplifiers (20 A, 40 A, 60 A, 80 A) up to an intermediate circuit voltage of 325 V_{DC}
- ▶ 6 HU servo amplifiers (20 A, 40 A, 60 A, 80 A) up to an intermediate circuit voltage of 680 V_{DC}
- ▶ Servo amplifiers in front connection design (20 A, 40 A, 60 A) up to an intermediate circuit voltage of 325 V_{DC}
- ▶ Servo amplifiers in front connection design (20 A, 40 A, 60 A) up to an intermediate circuit voltage of 680 V_{DC}
- ▶ All servo amplifiers provide high rated current ranges.

See also “[Technical Data](#)”, page 25.

Power Supply

- ▶ 3-phase supply of 115 V_{AC} up to 230 V_{AC}, 50 Hz/60 Hz
 - ▶ 3-phase supply directly at the earthed mains, 34 V_{AC} up to 480 V_{AC}, 50 Hz/60 Hz
 - ▶ 1-phase supply with neutral conductor, 115 V_{AC} up to 230 V_{AC}, 50 Hz/60 Hz
- Protection by the user.

Logic Voltage Supply

- ▶ Supply of AC voltage
 - 1-phase with neutral conductor, 115 V_{AC} up to 230 V_{AC}, 50 Hz/60 Hz
 - 2-phase, 34 V_{AC} up to 480 V_{AC}, 50 Hz/60 Hz
- ▶ Supply of 24 V_{DC} voltage

Power Section

- ▶ Potential-isolated power section
- ▶ IGBT output stage with an operating frequency of 8 kHz or 16 kHz
- ▶ Compact amplifiers with
 - integrated mains supply
 - integrated ballast circuit

Operation and Parametrization

- ▶ The parameters are set with the comfortable startup software via the serial interface of a PC
- ▶ Status indication directly at the servo amplifier
- ▶ The servo amplifier can also be controlled via the serial interface

Complete Digital Control

- ▶ All-digital current control (sample rate 62.5 μ s)
- ▶ All-digital speed control (sample rate 250 μ s)
- ▶ Integrated position control (sample rate 250 μ s)
- ▶ All-digital evaluation of the motor measuring system (sine-cosine signals of a high-resolution encoder, resolver or Hall effect sensors)
- ▶ Encoder emulation (compatible to ROD 426) with a maximum signal frequency of 1 MHz per track
- ▶ Resolver evaluation up to 40,000 rpm

Open Architecture

- ▶ Slots for the expansion with
 - various motor measuring systems
 - various ref. value interfaces
 - user-specific connections and extension units
- ▶ Software can easily be expanded for user-specific functions

Interfaces

- ▶ 3 analog ref. value interfaces (update rate 250 μ s with a resolution of 12 bits)
- ▶ 2 analog monitor outputs (update rate 125 μ s with a resolution of 10 bits)
- ▶ 8 programmable digital inputs
- ▶ 4 programmable digital outputs
- ▶ RS232/485 interface

Monitoring Functions

- ▶ Configuration check of the hardware and drive data
- ▶ Monitoring
 - short-circuit of the power output stage
 - of the power output stage temperature
 - I²t of the motor and the output stage
 - of the motor temperature via PTC/NTC contacts
 - excessive speed of the motor
 - of the motor measuring system (resolver, Hall effect sensors, sine-cosine encoder)
 - of the intermediate circuit voltage (undervoltage/overvoltage)
 - of the activation of the power supply (at compact amplifiers).
 - of the power supply
 - I²t of the brake chopper
- ▶ Detection of broken motor cables



6.1 Block Diagram

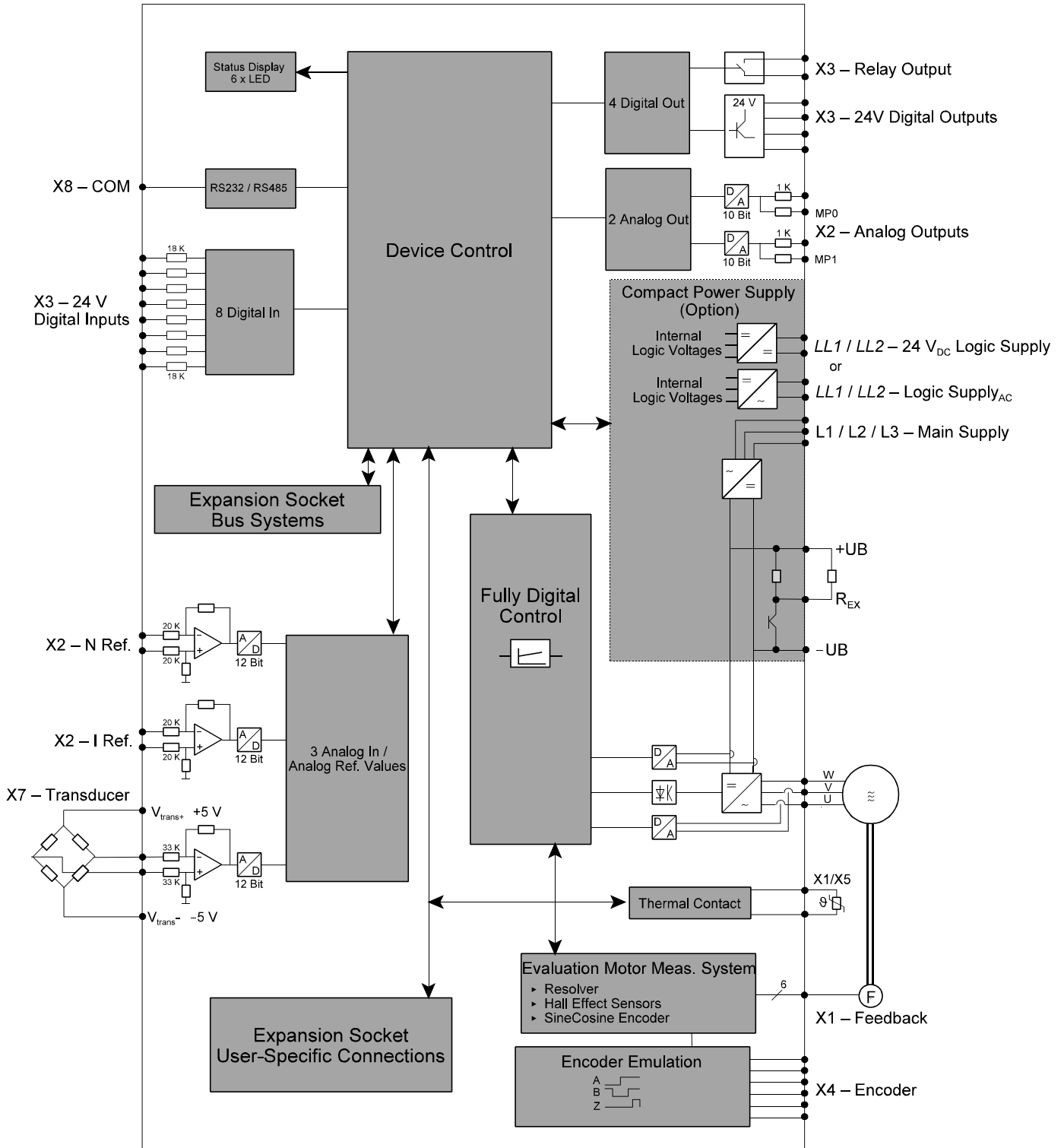

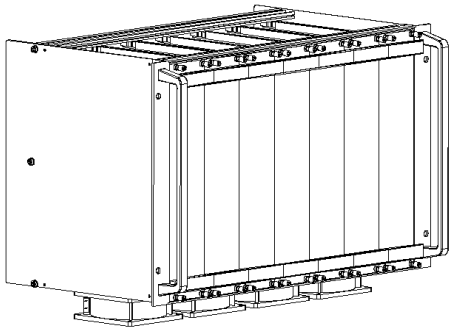
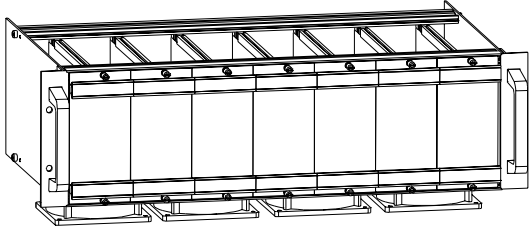

6.2 Standard Configuration of *sinudyn-36*

Hinged Frame, 6 HU, 12 to 84 WU		Hinged Frame, 3 HU, 12 to 84 WU	
			
<i>Number</i>	<i>Component</i>	<i>Number</i>	<i>Component</i>
1	chassis , page 29	1	chassis , page 30
1	power supply 6 HU, page 28	1 to 7	compact servo modules 3 HU, page 26
1	back plane 6 HU for power supply, see manual "Power Module 26.50.65"	1 to 7	back planes 3 HU for compact modules, page 43
1 to 6	multi-axis servo modules 6 HU, page 25	1 to 7	option modules for measuring system
1 to 6	back planes 6 HU for servo modules, page 43	1 to 3	fans 12 WU / 24 WU
1 to 6	option modules for measuring system	1	system software <i>sinudyn-36</i>
1 to 3	fans 24 WU		
1	internal connecting cable		
1	external ballast resistor		
1	system software <i>sinudyn-36</i>		
<i>Alternatively</i>			
1	chassis		
1 to 7	compact servo modules 6 HU		
1 to 7	back planes 6 HU for compact modules		
1 to 7	option modules for measuring system		
1 to 3	fans 12 WU / 24 WU		
1	system software <i>sinudyn-36</i>		

Wall Mounting, 6 HU, 12 to 84 WU	Front Connection Design																																																														
<p><i>Fig.: Compact servo module</i></p>																																																															
<table border="1"> <thead> <tr> <th>Number</th> <th>Component</th> </tr> </thead> <tbody> <tr> <td>1</td> <td>chassis, page 30</td> </tr> <tr> <td>1</td> <td>power supply 6 HU, page 28</td> </tr> <tr> <td>1</td> <td>back plane 6 HU for power supply, see manual "Power Module 26.50.65"</td> </tr> <tr> <td>1 to 6</td> <td>multi-axis servo modules 6 HU, page 25</td> </tr> <tr> <td>1 to 6</td> <td>back planes 6 HU for servo modules, page 43</td> </tr> <tr> <td>1 to 6</td> <td>option modules for measuring system</td> </tr> <tr> <td>1 to 3</td> <td>fans 24 WU</td> </tr> <tr> <td>1</td> <td>internal connecting cable</td> </tr> <tr> <td>1</td> <td>external ballast resistor</td> </tr> <tr> <td>1</td> <td>system software <i>sinudyn-36</i></td> </tr> </tbody> </table> <p><i>Alternatively</i></p> <table border="1"> <tbody> <tr> <td>1</td> <td>chassis</td> </tr> <tr> <td>1 to n</td> <td>compact servo modules 6 HU</td> </tr> <tr> <td>1 to n</td> <td>back planes 6 HU for compact modules</td> </tr> <tr> <td>1 to n</td> <td>option modules for measuring system</td> </tr> <tr> <td>1 to n</td> <td>fans 12 WU / 24 WU</td> </tr> <tr> <td>1</td> <td>system software <i>sinudyn-36</i></td> </tr> </tbody> </table>	Number	Component	1	chassis , page 30	1	power supply 6 HU, page 28	1	back plane 6 HU for power supply, see manual "Power Module 26.50.65"	1 to 6	multi-axis servo modules 6 HU, page 25	1 to 6	back planes 6 HU for servo modules, page 43	1 to 6	option modules for measuring system	1 to 3	fans 24 WU	1	internal connecting cable	1	external ballast resistor	1	system software <i>sinudyn-36</i>	1	chassis	1 to n	compact servo modules 6 HU	1 to n	back planes 6 HU for compact modules	1 to n	option modules for measuring system	1 to n	fans 12 WU / 24 WU	1	system software <i>sinudyn-36</i>	<table border="1"> <thead> <tr> <th>Number</th> <th>Component</th> </tr> </thead> <tbody> <tr> <td>1 to n</td> <td>complete units</td> </tr> <tr> <td>1 to n</td> <td>option modules for measuring system</td> </tr> <tr> <td>1</td> <td>system software <i>sinudyn-36</i></td> </tr> </tbody> </table> <table border="1"> <thead> <tr> <th colspan="2"><i>connectors</i></th> </tr> </thead> <tbody> <tr> <td>X30</td> <td>power supply</td> </tr> <tr> <td>X3A + B</td> <td>digital inputs and outputs, page 53</td> </tr> <tr> <td>LEDs</td> <td>status indication, page 61</td> </tr> <tr> <td></td> <td>test pins</td> </tr> <tr> <td>X8</td> <td>COM1, page 58</td> </tr> <tr> <td>X4</td> <td>angle pulses, page 48</td> </tr> <tr> <td>X2</td> <td>analog signals, page 52</td> </tr> <tr> <td>X7</td> <td>transducer, page 58</td> </tr> <tr> <td>X1</td> <td>motor measuring system, page 49</td> </tr> </tbody> </table> <p> For compact amplifiers with front connection design a separate technical description is available, see "<i>sinudyn-36</i> Hardware Description 36.05.xx Front Connection Design".</p>	Number	Component	1 to n	complete units	1 to n	option modules for measuring system	1	system software <i>sinudyn-36</i>	<i>connectors</i>		X30	power supply	X3A + B	digital inputs and outputs, page 53	LEDs	status indication, page 61		test pins	X8	COM1, page 58	X4	angle pulses, page 48	X2	analog signals, page 52	X7	transducer, page 58	X1	motor measuring system, page 49
Number	Component																																																														
1	chassis , page 30																																																														
1	power supply 6 HU, page 28																																																														
1	back plane 6 HU for power supply, see manual "Power Module 26.50.65"																																																														
1 to 6	multi-axis servo modules 6 HU, page 25																																																														
1 to 6	back planes 6 HU for servo modules, page 43																																																														
1 to 6	option modules for measuring system																																																														
1 to 3	fans 24 WU																																																														
1	internal connecting cable																																																														
1	external ballast resistor																																																														
1	system software <i>sinudyn-36</i>																																																														
1	chassis																																																														
1 to n	compact servo modules 6 HU																																																														
1 to n	back planes 6 HU for compact modules																																																														
1 to n	option modules for measuring system																																																														
1 to n	fans 12 WU / 24 WU																																																														
1	system software <i>sinudyn-36</i>																																																														
Number	Component																																																														
1 to n	complete units																																																														
1 to n	option modules for measuring system																																																														
1	system software <i>sinudyn-36</i>																																																														
<i>connectors</i>																																																															
X30	power supply																																																														
X3A + B	digital inputs and outputs, page 53																																																														
LEDs	status indication, page 61																																																														
	test pins																																																														
X8	COM1, page 58																																																														
X4	angle pulses, page 48																																																														
X2	analog signals, page 52																																																														
X7	transducer, page 58																																																														
X1	motor measuring system, page 49																																																														



6.3 Module Designation

036.XX.XX-XX

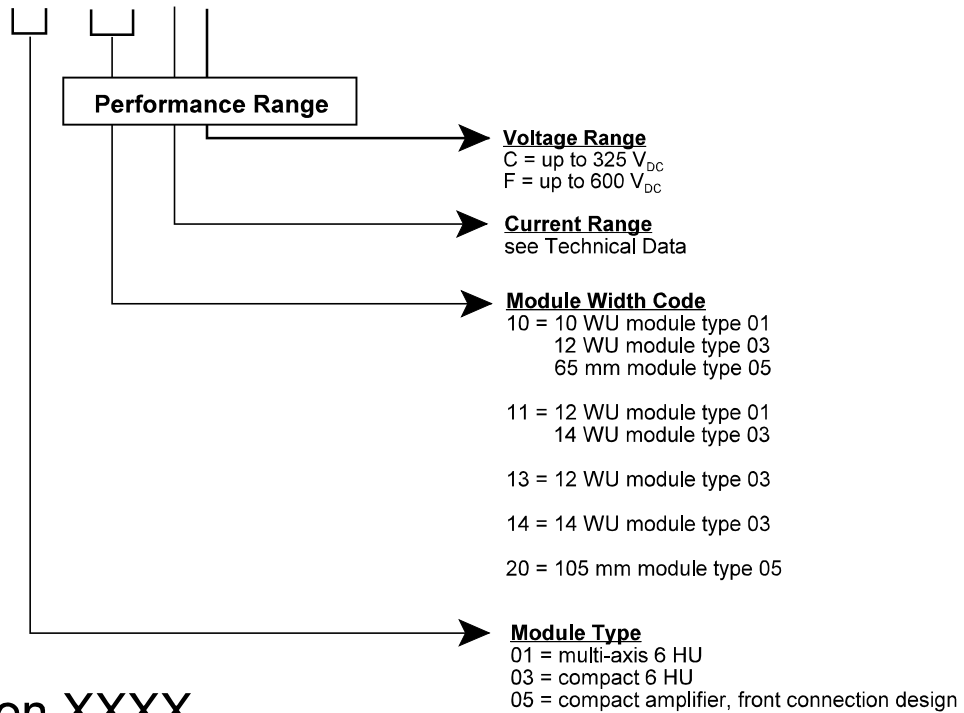

Option XXXX

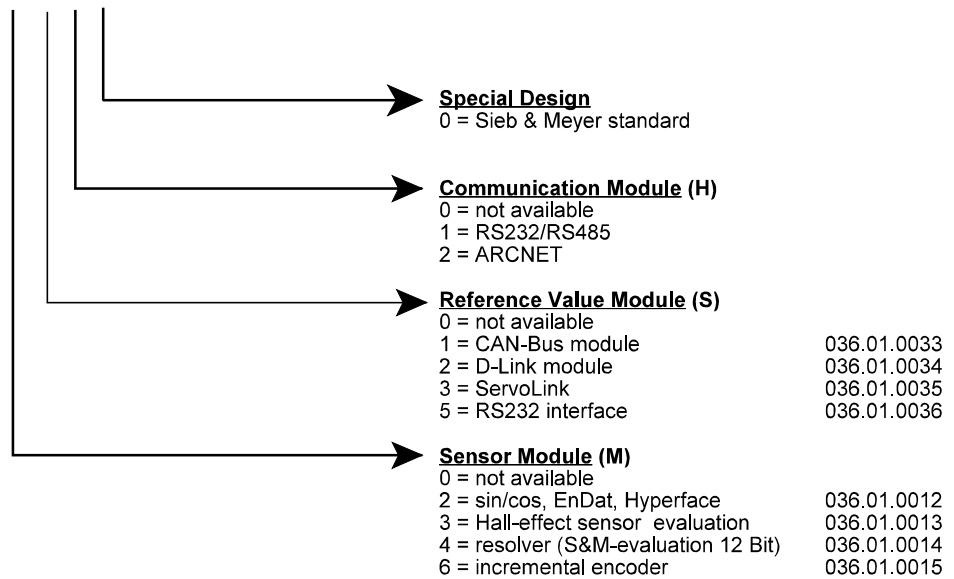

7 Technical Data

7.1 Multi-Axis Servo Modules of Series *sinudyn-36*

7.1.1 Intermediate Circuit Voltage 48 V_{DC} up to 325 V_{DC}

Type	36.01.10xx ¹				36.01.11xx ¹			36.01.12.xx ¹	
	DC	EC	SC	TC	MC	ZC	LC	IC	QC
Rated current ² , ventilated with fan EL 1.23.1 [A]	12	12	12	12	20	20	30	45	45
Peak current ² [A]	20	40	60	80	60	40	80	80	100
Intermediate circuit voltage [V _{DC}]	up to 325 +10 %								
Temperature range [°C]	+5 to +60 (100 % rated current up to 40)								
Reduction of rated current for ambient temperatures >40°C	-1.5 % per 1°C								
Width [WU]	10			12			16		
Height [HU]	6								

- ¹ xx is replaced by the respective code letter of the current range and voltage range (e.g. DC),
- ² see page 24
The maximum values are sustainable for up to 5 s.

Rated and peak currents are sine crest values. Specifications apply for 8 kHz operating frequency of the output stage.

7.1.2 Intermediate Circuit Voltage up to 680 V_{DC}

Type	36.01.10xx ¹				36.01.11xx ¹				36.01.12xx ¹	
	DF	EF	SF	TF	FF	GF	KF	LF	HF	IF
Rated current ² , ventilated with fan EL 1.23.1 [A]	8	8	8	8	12	12	15	15	22	22
Peak current ² [A]	20	40	60	80	20	40	60	80	60	80
Intermediate circuit voltage [V _{DC}]	up to 680 +10 %									
Temperature range [°C]	+5 bis +60 (100 % rated current up to 40)									
Reduction of rated current for ambient temperatures >40°C	-1.5 % per 1°C									
Width [WU]	10			12			16			
Height [HU]	6									

- ¹ xx is replaced by the respective code letter of the current range and voltage range (e.g. DC),
- ² see page 24
The maximum values are sustainable for up to 5 s.

Rated and peak currents are sine crest values. Specifications apply for 8 kHz operating frequency of the output stage.

7.2 Compact Amplifiers of Series *sinudyn-36*

7.2.1 Intermediate Circuit Voltage 48 V_{DC} up to 325 V_{DC}

Type	36.04.10xx ¹		36.03.10xx ¹				36.03.11xx ¹		
Current range/voltage range	DC	EC	DC	EC	SC	TC	MC	ZC	LC
Main supply ³	34 V _{AC} up to 230 V _{AC}		115 V _{AC} up to 230 V _{AC}						
Logic supply	24 V _{DC}		two phases, same potential as main supply						
Resulting intermediate circuit voltage	48 V _{DC} up to 325 V _{DC}		162 V _{DC} up to 325 V _{DC}						
Rated current of the output stage ventilated with fan EL 1.16.2 [A]	10	10	12	12	12	12	20	21	30
Peak current ² of the output stage [A]	20	30	20	40	60	80	60	40	80
Rated d.c. of the integrated power module, single-phase supply	0,1666666667								
Rated d.c. of the integrated power module, three-phase supply	0,2916666667								
Power of the integrated power module, single-phase supply	0,14 kVA to 0,9 kVA								
Power of the integrated power module, three-phase supply	0,24 kVA to 1,6 kVA								
min. external ballast resistor	22 Ω								
Temperature range	5°C to 60°C up to a maximum of 95 % relative humidity (no moisture condensation) 100 % rated current up to 40°C								
Reduction of the nominal current at ambient temperatures > 40°C	- 1,5 % per 1°C								
Heights > 1000 m (3281 ft) M.S.L.	- 15 % per 1000 m increase								
Width [WU]	12		12				14		
Height [HU]	3		6				6		

¹ xx is replaced by the respective code letter of the current range and voltage range (e. g. DC), see page 24

² single-phase or three-phase supply possible

³ the maximum values are sustainable for up to 5 s



Rated and peak currents are sine crest values. Specifications apply for 8 kHz operating frequency of the output stage.

7.2.2 Intermediate Circuit Voltage 48 V_{DC} up to 680 V_{DC}

Type	36.03.13xx ¹				36.03.14xx ¹			
Current range/voltage range	DF	EF	SF	TF	FF	GF	KF	LF
Main supply ²	34 V _{AC} up to 480 V _{AC}							
Logic supply	24 V _{DC}							
Resulting intermediate circuit voltage	48 V _{DC} up to 680 V _{DC}							
Rated current of the output stage ventilated with fan EL 1.16.2 [A]	8	8	8	8	12	12	15	15
Peak current ³ of the output stage [A]	20	40	60	80	20	40	60	80
Rated d.c. of the integrated power module	0,2916666667							
Power of the integrated power module, three-phase supply	0,24 kVA to 3,3 kVA							
min. external ballast resistor	47 Ω							
Temperature range	5°C to 60°C up to a maximum of 95 % relative humidity (no moisture condensation) 100 % rated current up to 40°C							
Reduction of the rated current at ambient temperatures > 40°C	- 1,5 % per 1°C							
Heights > 1000 m (3281 ft) M.S.L.	- 15 % per 1000 m increase							
Width [WU]	12				14			
Height [HU]	6				6			

¹ xx is replaced by the respective code letter of the current range and voltage range (e. g. DC), see page 24

² only three-phase supply possible

³ the maximum values are sustainable for up to 5 s

Rated and peak currents are sine crest values. Specifications apply for 8 kHz operating frequency of the output stage.

7.2.3 Protection of the Compact Amplifiers 36.03.xx

Intermediate Circuit Voltage of 48 V_{DC} up to 325 V_{DC}

1-phase supply: 6 A max. 0.14 kVA up to 0.90 kVA
 3-phase supply: 6 A max. 0.24 kVA up to 1.60 kVA

Intermediate Circuit Voltage up to 680 V_{DC}

3-phase supply: 6 A max. 1.60 kVA up to 3.30 kVA

7.3 Power Modules 26.50.65 and 26.50.88

 For the power modules 26.50.65 and 26.50.88 a separate technical description in German and English is available.

Power Modules		26.50.65	26.50.88
Performance range		16/50	16/70
Main supply		3 x 70 V _{AC} + 10 % - 20 %	
		3 x 230 V _{AC} + 10 % - 20 %	
		3 x 250 V _{AC} + 10 % - 20 %	
		3 x 280 V _{AC} + 10 % - 20 %	
		3 x 380 V _{AC} up to 480 V _{AC} + 10 % - 5 %	
Logic supply		two-phase supply, same potential as main supply	
Rated d.c. in the intermediate circuit ¹		16 A	
Peak d.c. in the intermediate circuit ²		50 A	70 A
Letter code of the intermediate circuit voltage	B	100 V _{DC} + 10 % - 20 %	
	C/CZ ³	325 V _{DC} + 10 % - 20 %	
	K	350 V _{DC} + 10 % - 20 %	
	I	400 V _{DC} + 10 % - 20 %	
	H	540 V _{DC} up to 680 V _{DC} + 10 % - 20 %	
Rated power in the intermediate circuit according to voltage range	B	1,4 kW	
	C/CZ ³	7 kW	
	K	7 kW	
	I	5,5 kW	
	H	10 kW	
Rated power of the logic supply for servo modules of the different voltage ranges	B	100 W	
	C/CZ ³	180 W	
	K	180 W	
	I	150 W	
	H	150 W	
Power of the +5V MSY for external applications		9 W	
min. external ballast resistor according to voltage range	B	5 Ω (220 W / 440 W ⁴)	
	C/CZ ³	5 Ω (220 W / 440 W ⁴)	
	K	5 Ω (220 W / 440 W ⁴)	
	I	10 Ω (220 W / 440 W ⁴)	
	H	10 Ω (220 W / 440 W ⁴)	
Temperature range		5°C to 60°C up to a max. of 95 % relative humidity (no moisture condensation), 100 % rated current up to 40°C	
Reduction of the rated current at ambient temperatures > 40°C		- 1,5 % per 1°C	
Heights > 1000 m (3281 ft) M.S.L.		- 15 % per 1000m increase	
Width [WU]		14	
Height [HU]		6	

¹ fan cooling, min. air flow rate 45l/s, for example with S&M fan EL 1.23.1

² the maximum values are sustainable for up to 1 s

³ power module without overvoltage protection

⁴ see jumper J3/J4 board 26.50.0073

 **When rating the drive, consider that the rated and peak currents of the power module (current of the intermediate circuit) are not comparable with those of the servo module (current to the AC motor).**

7.4 Chassis
7.4.1 Design of the Multi-Axis Chassis, 6 HU

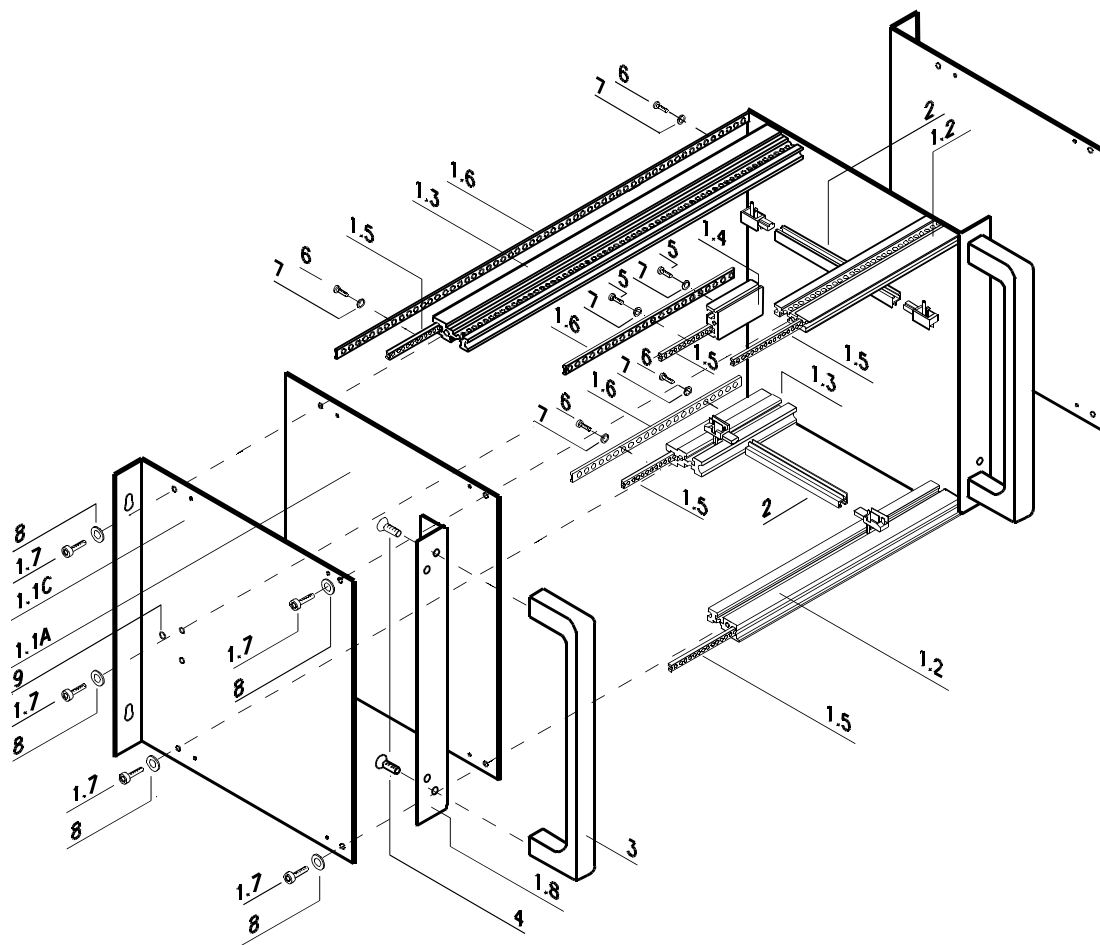

- 1.1A/C Aluminum side panels BA 6/1 (right/left)
- 1.2 Aluminum front rail 84 WU
- 1.3 Aluminum rear rail 84 WU
- 1.4 Central aluminum rail 84 WU
- 1.5 Brass rail with tapped hole M2.5
- 1.6 Plastic rod with hole
- 1.7 Phillips screw M4×12
- 1.8 rack angle plate, anthracite, 6 HU
- 2 Aluminum card guide rails, 180 mm in total
- 3 Housing grips
- 4 Countersunk head screws M5×10
- 5 Pan head screws M2.5×10
- 6 Pan head screws M2.5×12
- 7 Crinkled spring washer M2.5
- 8 Crinkled spring washer M4
- 9 Fixing hole for the grounding

7.4.2 Design of the Multi-Axis Chassis, 3 HU

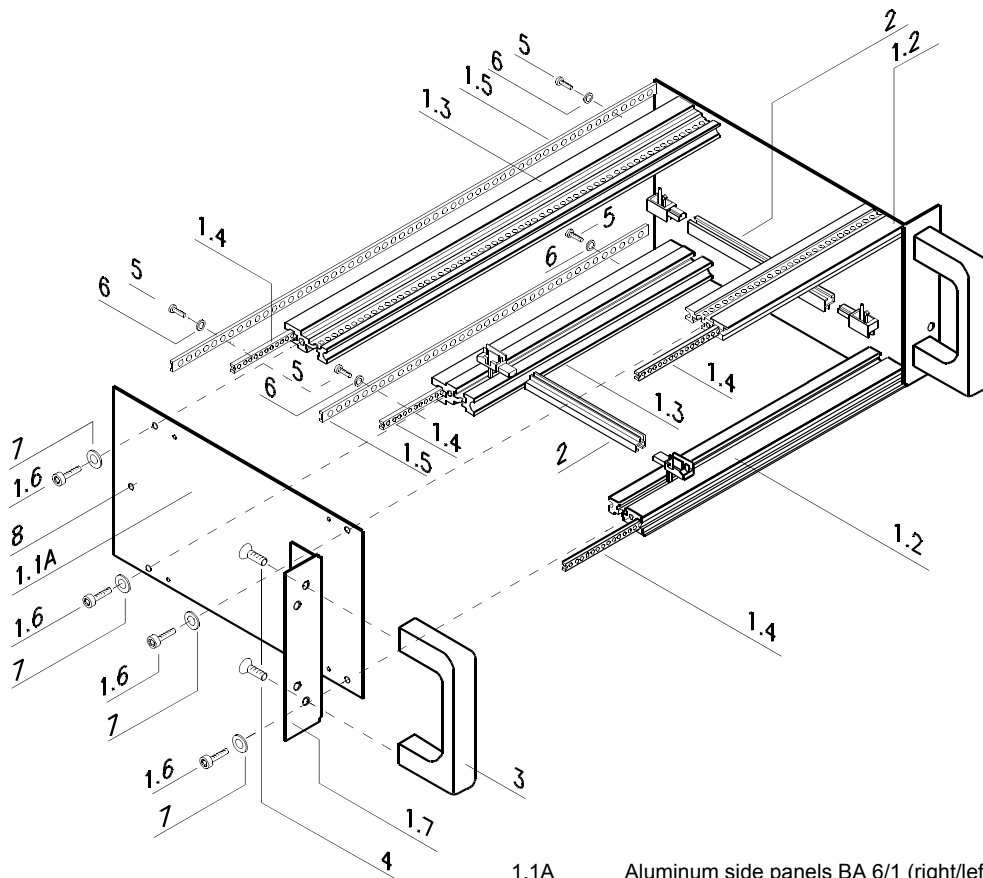

- 1.1A Aluminum side panels BA 6/1 (right/left)
- 1.2 Aluminum front rail 84 WU
- 1.3 Aluminum rear rail 84 WU
- 1.4 Central aluminum rail 84 WU
- 1.5 Brass rail with tapped hole M2.5
- 1.6 Phillips screw M4×12
- 1.7 rack angle plate, anthracite, 3 HU
- 2 Aluminum card guide rails, 180 mm in total
- 3 Housing grips
- 4 Countersunk head screws M5×10
- 5 Pan head screws M2.5×10
- 6 Crinkled spring washer M2.5
- 7 Crinkled spring washer M4
- 8 Fixing hole for the earth connection

8 Dimensioned Drawings

8.1 6 HU Chassis for Wall Mounting (Compact Amplifier)

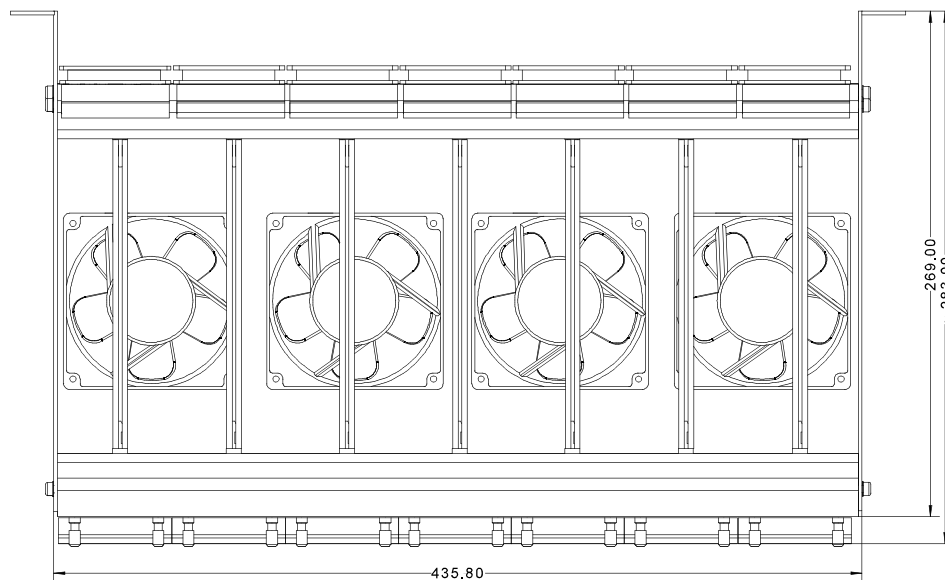
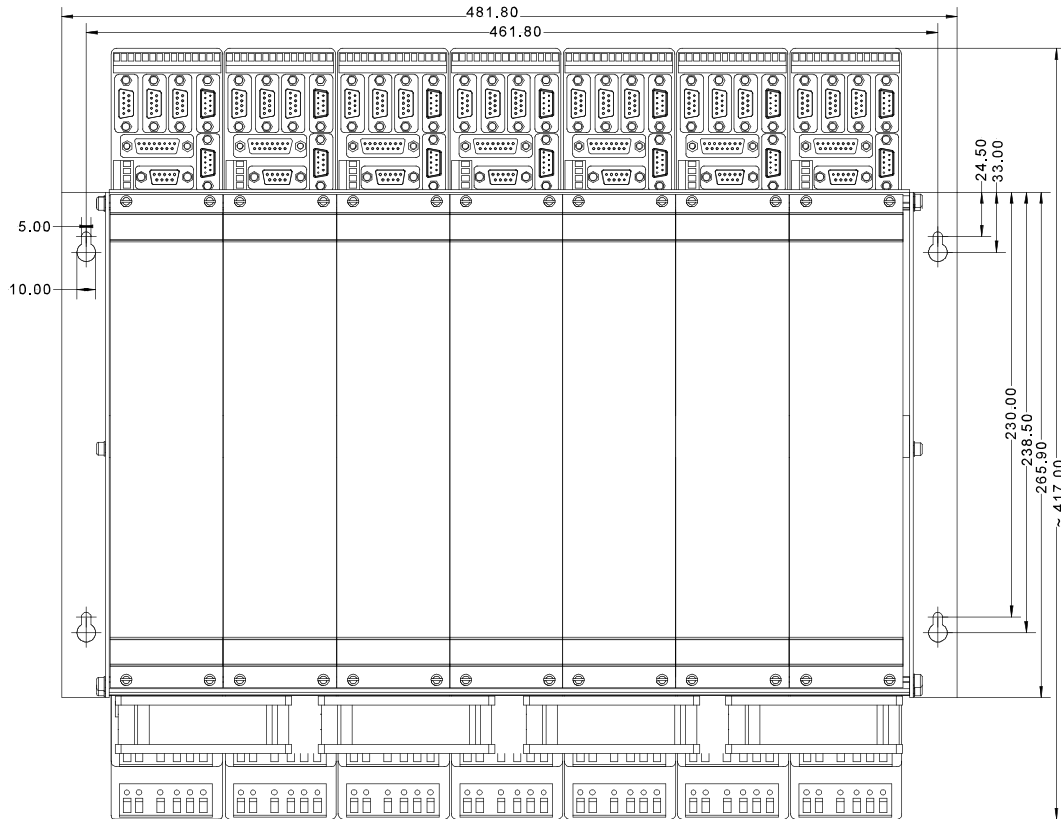

8.2 6 HU Chassis for Hinged Frame Mounting

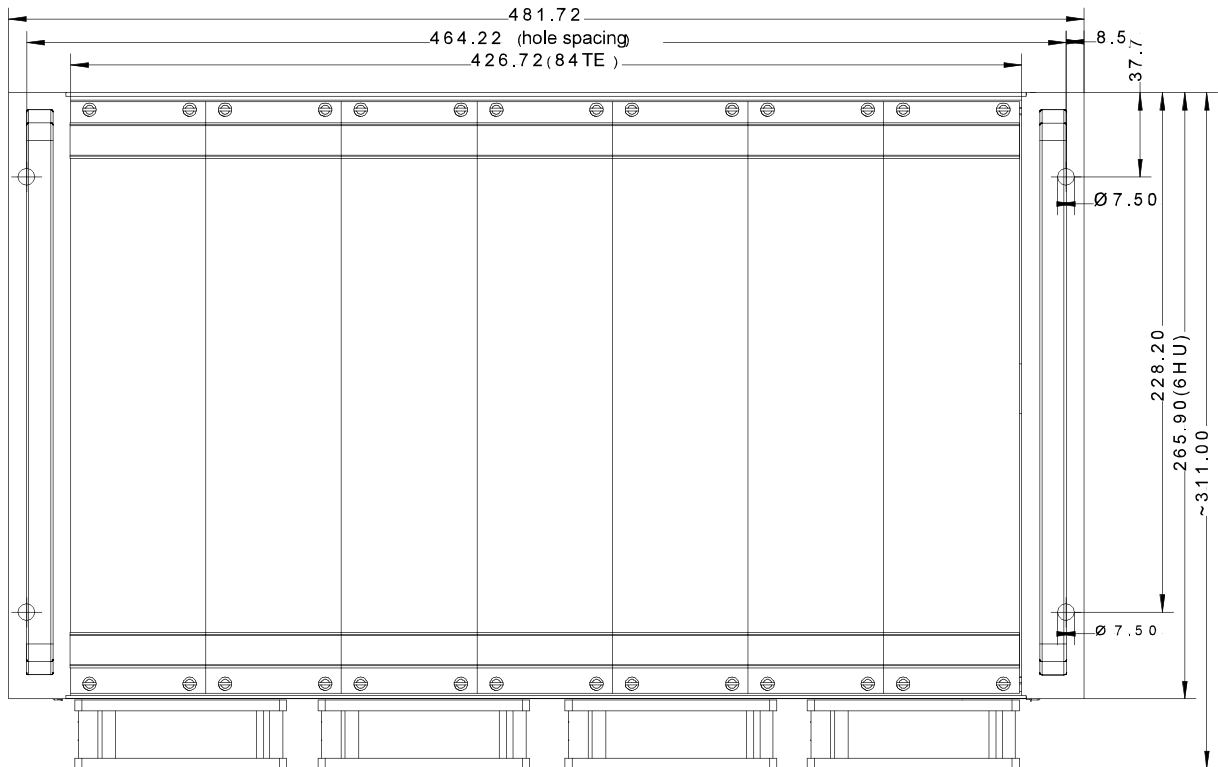

Front view

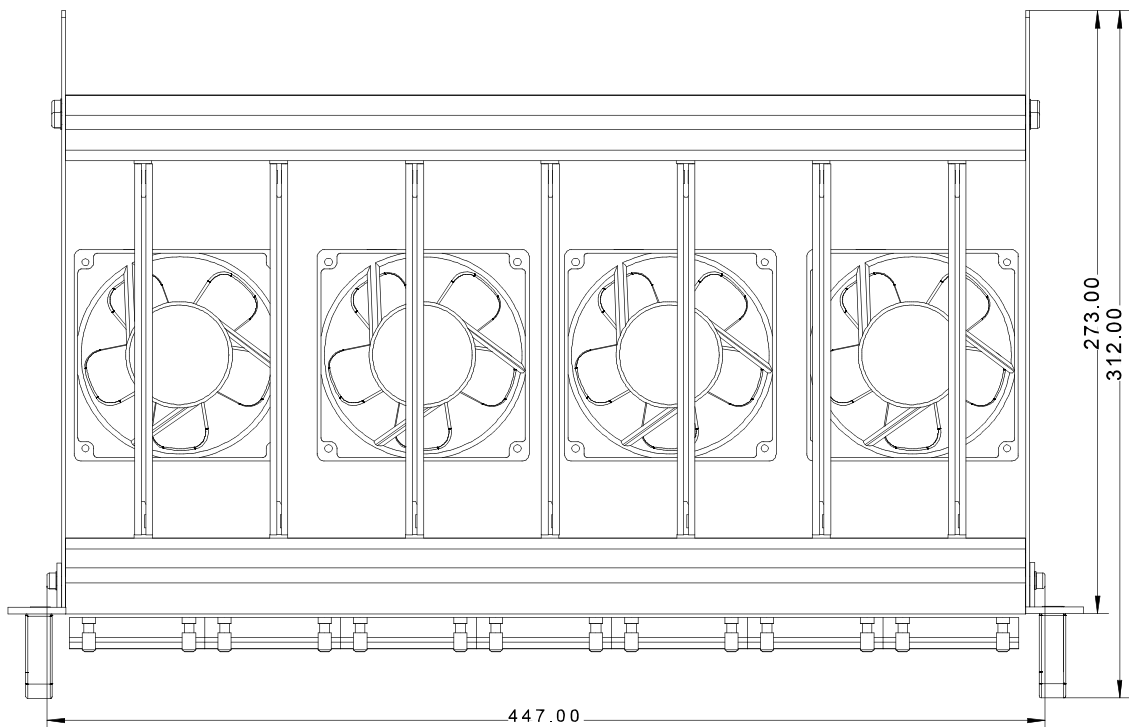

Top view

8.3 3 HU Chassis for Hinged Frame Mounting

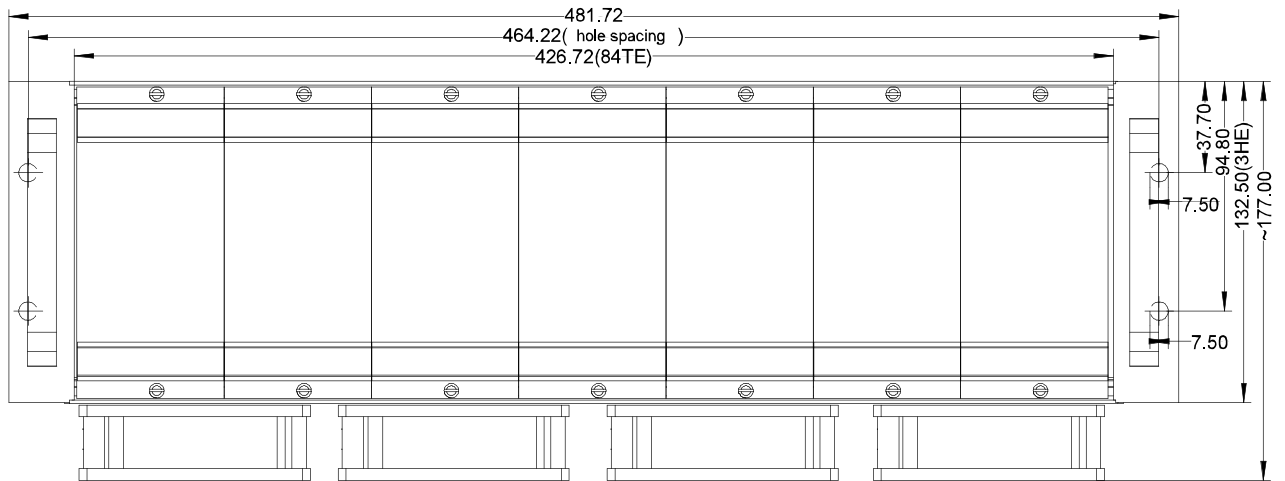

Front view

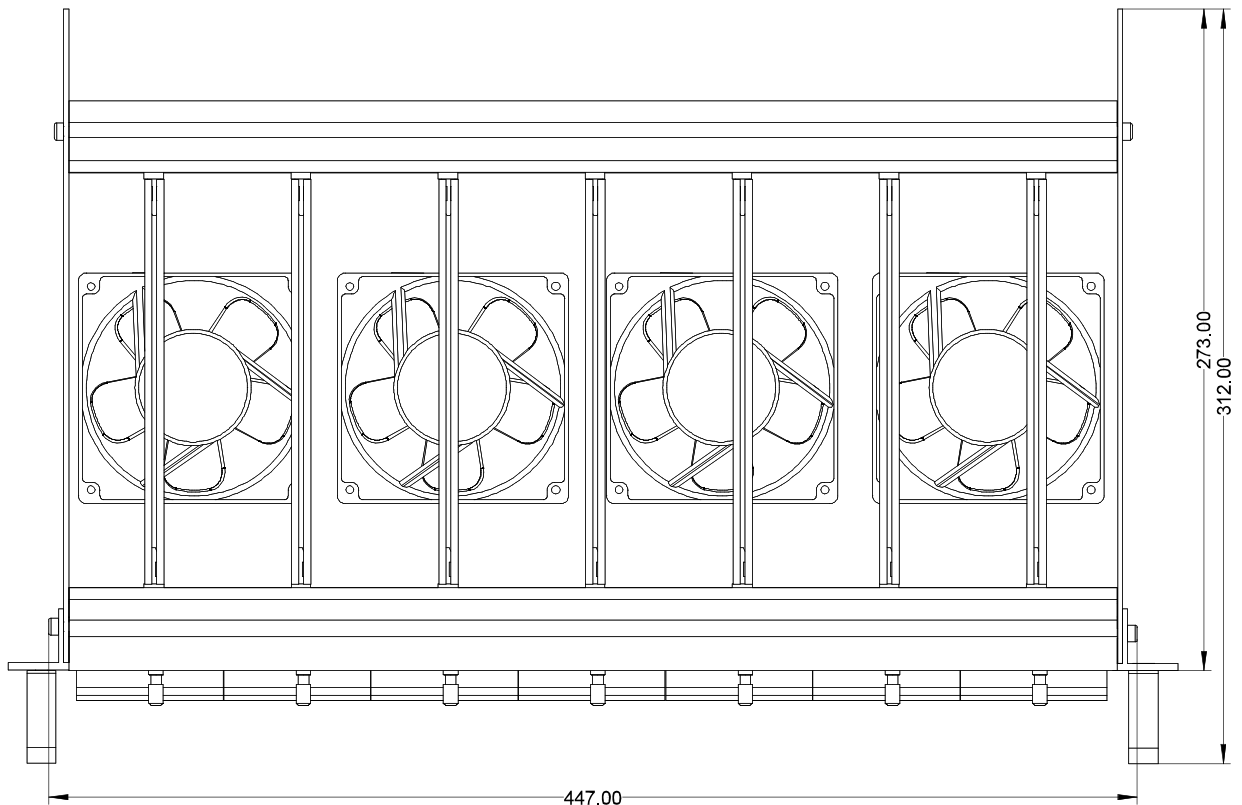

Top view



9 Mechanical Mounting

The power and servo modules of the multi-axis system are mounted into a 19" chassis facilitating the easy replacement of modules by detaching two stop screws.

The chassis has to be mounted vertically. Customary hinged frames or frames for wall-mounting have been proved to be valuable for the mounting of the chassis into a switch cabinet.

The modules of the compact system are integrated in a shortened chassis for wall-mounting. They can also easily be replaced by detaching four stop screws.

- ▶ After inserting the modules, it is indispensable to firmly fasten the stop screws. Otherwise, a secure contact of the plug-in connectors will not be given. An insecure contact to the back plane can damage the plug-in connectors!
- ▶ The modules must only be replaced, when the lines are **dead!**



- ▶ **Above and below the chassis at least a space of 10 cm must be provided to ensure sufficient cooling.**
- ▶ **The modules have a very compact design. Using extraneous fans for the servo modules is necessary to prolong the life expectancy and keep the efficiency of 100 % at an ambient temperature of up to 40°C.**
- ▶ **The life expectancy of an electrolytic capacitor integrated in the amplifier, for example, is defined as below:**
 - < 40°C = 100,000 hours**
 - = 85°C = 4,000 hours**
 - =105°C = 1,000 hours**

Thus, a reduction of $\Delta\theta = 10K$ doubles the life of the electrolytic capacitor.

9.1 Back Plane Fixing

The back planes have to be fastened with six screws to ensure a good connection between back plane and servo module. Make sure that a reliable connection between back plane and module is given when inserting the module. An incorrect connection can cause the burning of contacts and, thus, destroy the module.

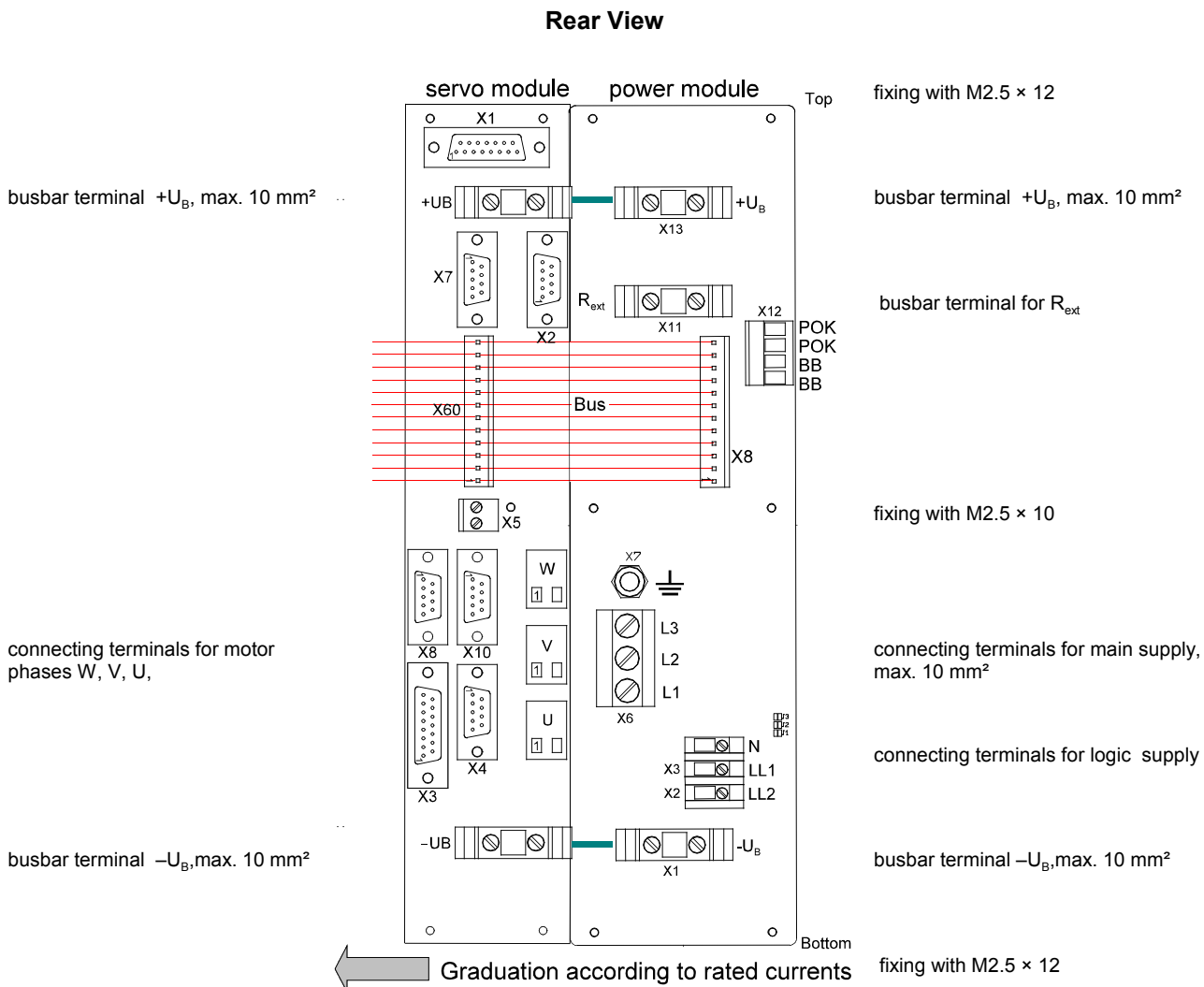

The graduation corresponds to the respective rated currents of the servo modules. This means, that the servo module with the lowest rated current is mounted farthest to the power module.

The power module must always be mounted left of the servo modules (eyes on front side) in the chassis.

9.2 Replacement of Servo Modules

The modular design of the SIEB & MEYER servo module systems facilitates the replacement of a complete rack.



Racks must only be replaced, when the lines are dead.



**Pay attention of the correct parameterization of the drive.
See "*sinudyn-36, Software Description*".**

If a module fails, usually only the faulty module must be replaced as service and, the new module must be parameterized. Please consider that the module must only be pushed in or off, when the lines are **dead**.



10 General Information Regarding the Wiring

The conductor cross sections should be selected carefully, so that the max. admissible current is not exceeded at the max. ambient temperature (the max. ambient temperature of the servo module is 60°C). **DIN 60204-1** defines the admissible values for the separate cross sections, which must absolutely be considered.

The following table shows the current carrying capacity in combination with the conductor cross-section of copper leads, isolated with polyvinyl chloride or cables according to DIN/EN 60204-1 for wiring type B2 and an ambient temperature of +40°C:

Conductor Cross-Section A [mm ²]	Admissible Current I [A]
0.75	7.60
1.00	9.60
1.50	12.20
2.50	16.50
4.00	23.00
6.00	29.00
10.00	40.00
16.00	53.00
25.00	67.00
35.00	83.00

The following correction factors are provided for deviating ambient temperatures:

Ambient Temperature T [°C]	Correction Factor
30	1.15
35	1.08
40	1.00
45	0.91
50	0.82
55	0.71
60	0.58

Extract of the DIN 60204-1 "Safety of Machines/Electrical Equipment of Machines":

Direct Connection of the Earth Conductor System

All assemblies of the electrical equipment and the machine(s) must be connected to the earth conductor system.

This means: The motor must be grounded at the machine and, the machine must be connected to the controller via an earth conductor system according to the regulations.

Prevent multiple earth connections between motor and controller, so that earth loops are precluded.

In the CNC chassis the ground conductor system should **only** be connected with the back plane of the power module or at the earth screw of the chassis.



Higher leakage currents ($> 3.5 \text{ mA}$) can occur on the earth conductor (\perp) due to filters or the use of several servo amplifiers. Possibly a residual current operated device can be used then. According to DIN/EN 50178 - VDE 160 the electronic equipment must be equipped with a fixed connector in this case. Warnings must be provided in the documentation and at the unit.

An earth conductor of at least 10 mm^2 cross-section must be used or a second earth conductor must be wired electrically parallel to the earth conductor with separate clamps.

Annotation: The minimum cross-section has been chosen with consideration of its mechanical strength.

10.1 Motor Cables

Use shielded conductors for the motor to keep the interferences low as possible (conductor cross section according to the table). If possible, the shield must be connected with both ends and largest surface, otherwise single-ended at the shield bar. The shield bar can be supplied by SIEB & MEYER.

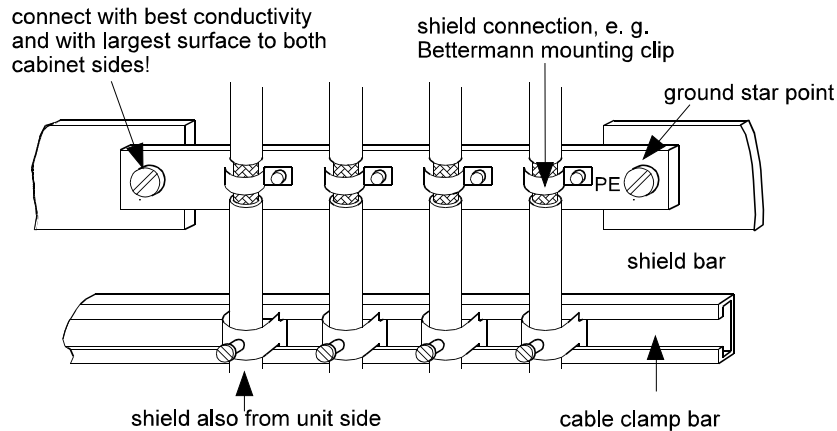

Earth conductors, additionally lead in motor cables must directly be put to the earth shield and be marked with \perp .

If the procedure turns out to be impracticable, omit the earth conductor connection in the motor cables and wire a separate earth conductor in parallel to the motor cables, preventing disturbing earth loops.

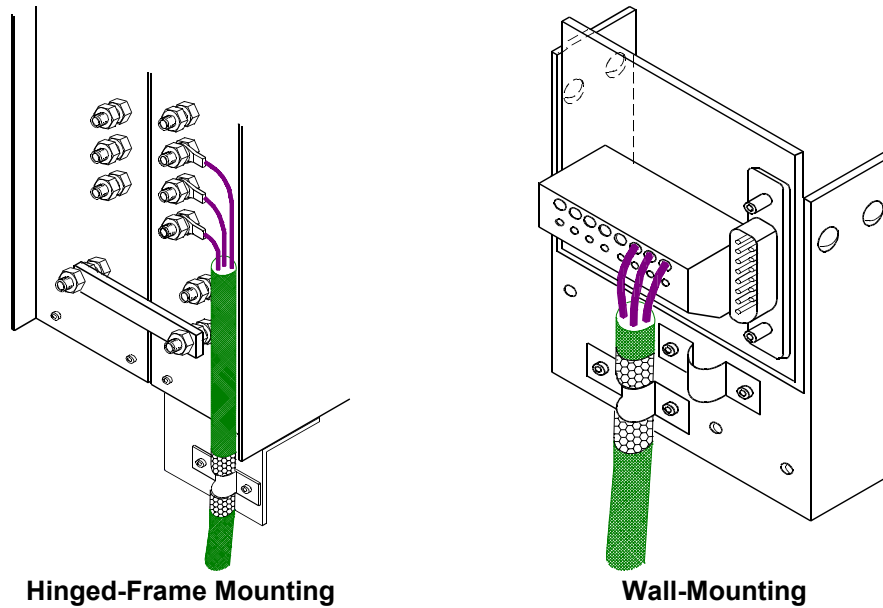

Hinged-Frame Mounting

Wall-Mounting

10.2 Shield Bars for Cables for Rotary Encoders

Use shielded conductors for the wiring of the different rotary encoders. For motors with an integrated resolver the cable must additionally be twisted.

Examples for the use of conductors:

- ▶ Motors with resolvers
LIYCY 3 × 2 × 0.14 or 4 × 2 × 0.14 for motors with integrated thermal contact.
Shielded, pairwise twisted conductors. Twist mode: sine/sine, cosine/cosine, rotor/rotor and, possibly thermal contact/thermal contact.
For delicate applications we recommend to additionally shield the separate pairs.
- ▶ Motors with incremental encoders
LIYCY 5 × 0.14 or 7 × 0.14 for motors with integrated thermal contact.
- ▶ Motors with Hall effect sensors and tachogenerator
LIYCY 9 × 0.14 or 12 × 0.14 for motors with integrated thermal contact.

The shield must be laid on the housing of connector X1. If possible, connect it also to the motor.

10.3 Wiring of the Analog Ref. Values

The ref. value is led to the PI speed controllers via a differential amplifier. This type of evaluation has been chosen due to obtained accuracy of the ref. value, which is a main criterion for the optimal function of the speed controller. In this way the differential amplifier counteracts interference voltages that, for example, may be caused by earth problems between position controller and servo module.

Wiring of the Analog Ref. Value (Asymmetric Ref. Value)

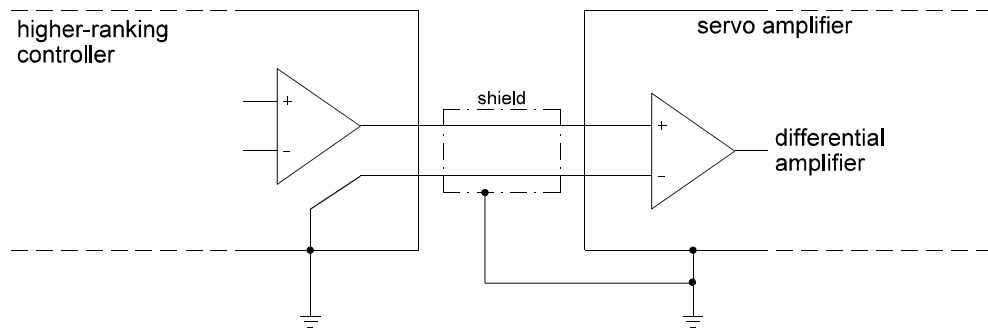

The example shows that the ref. value must be led to the differential amplifier of the servo module via two conductors. The negative ref. value input must be connected to earth in the higher-ranking position controller. LIYCY 2 × 0.14.

Wiring of a Symmetric Ref. Value

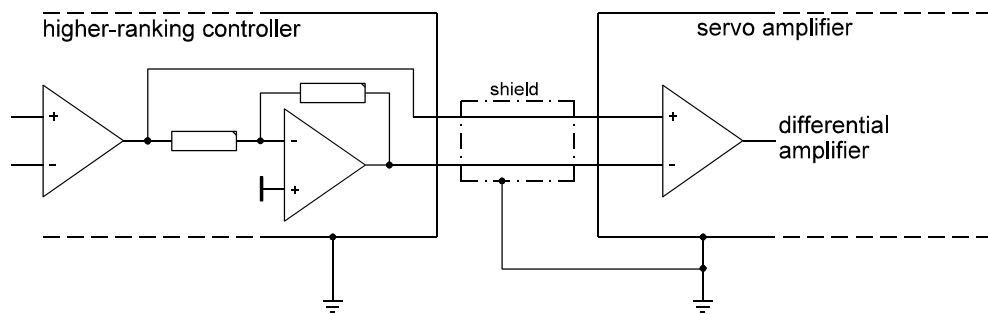

The example shows that both ref. values must be led from the higher-ranking controller to the differential amplifier of the servo module. LIYCY 2 × 0.14.

10.4 Wiring of the Angle Pulses

Use shielded conductors for the wiring of the angle pulses, such as LIYCY 6 × 0.14.

For delicate applications we recommend using pairwise twisted conductors, possibly with an additional shield of the separate pairs. Twist mode: U_{a1}/U_{a1} ; U_{a2}/U_{a2} ; U_{a0}/U_{a0} .

The shield must be laid on to the shell of connector X4 and to the controller.

11 Back Planes

11.1 Back Plane 36.01.0041.2

Multi-axis amplifier, 10 WU, hinged-frame mounting

Rear View

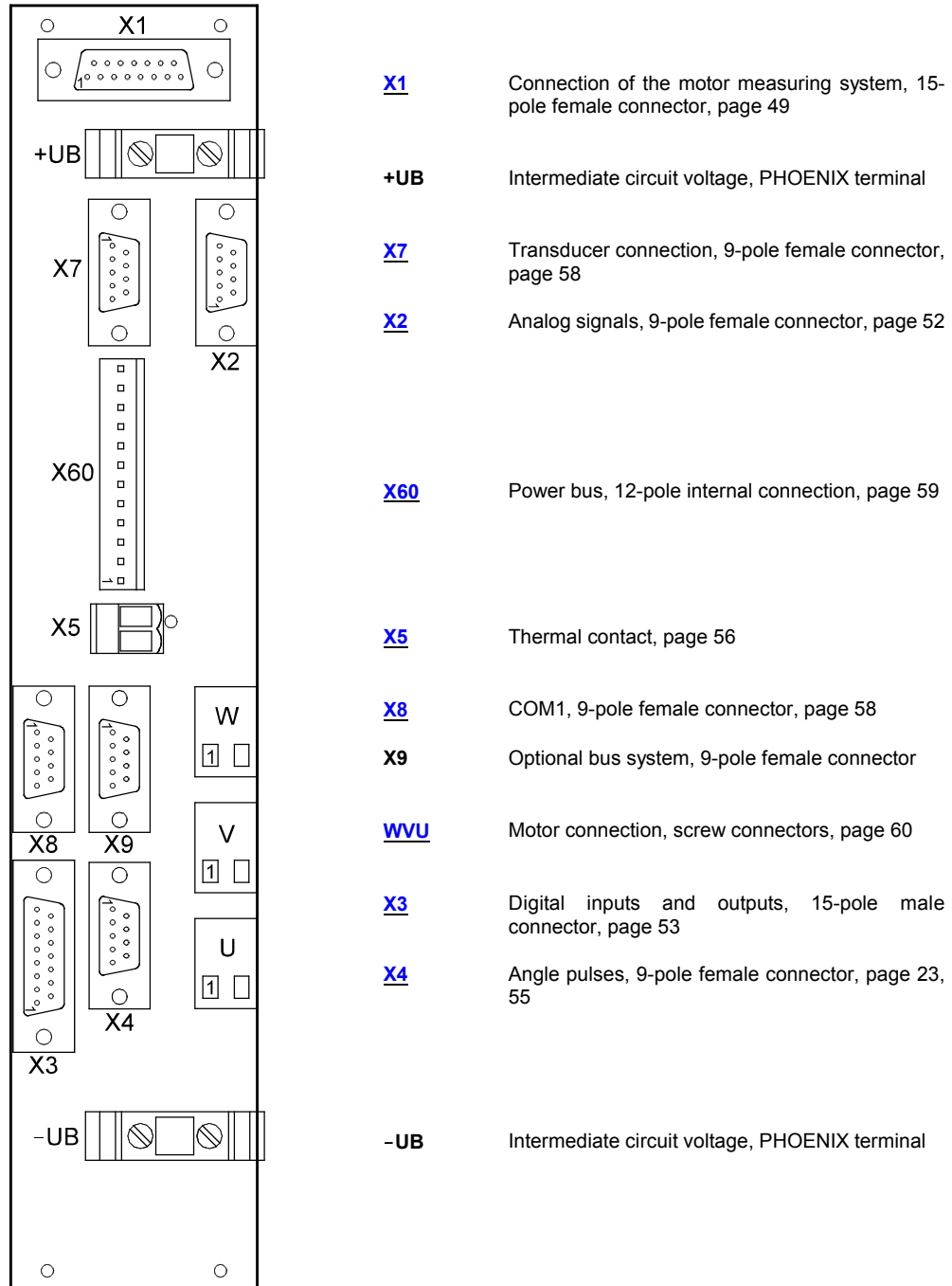

Use a Submin D connector with metal shell as counter connector, so that the shield can directly be connected at the shell.

11.2 Back Plane 36.01.0046

Multi-axis amplifier, 10 WU, hinged-frame mounting

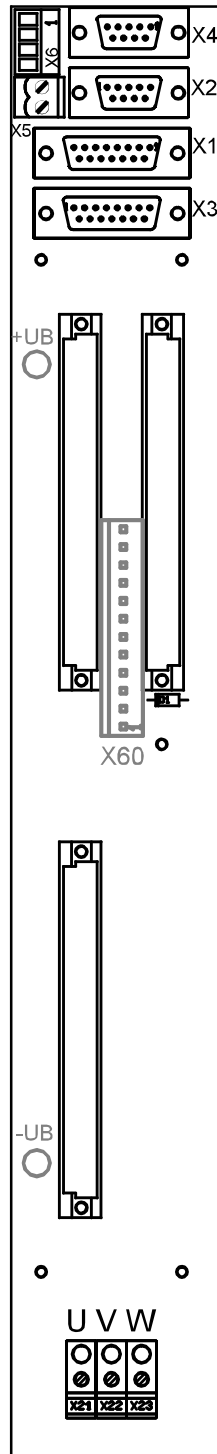

- [X6](#) Safeguard (option), page 57
- [X5](#) Thermal motor protection, page 56
- [X4](#) Angle pulses, 9-pole female connector, page ?
- [X2](#) Analog signals, 9-pole female connector, page 52
- [X1](#) Connection of the motor measuring system, 15-pole female connector, page 49
- [X3](#) Digital inputs and outputs, 15-pole male connector, page 53

+UB Intermediate circuit voltage, PHOENIX terminal

[X60](#) Powerbus, 12-pole internal connection, page 59

-UB Intermediate circuit voltage, PHOENIX terminal

[UVW](#) Motor connection, screw connectors, page 60

11.3 Back Plane 36.01.0042.1

Compact amplifier, 12 WU / 3 HU, hinged-frame mounting

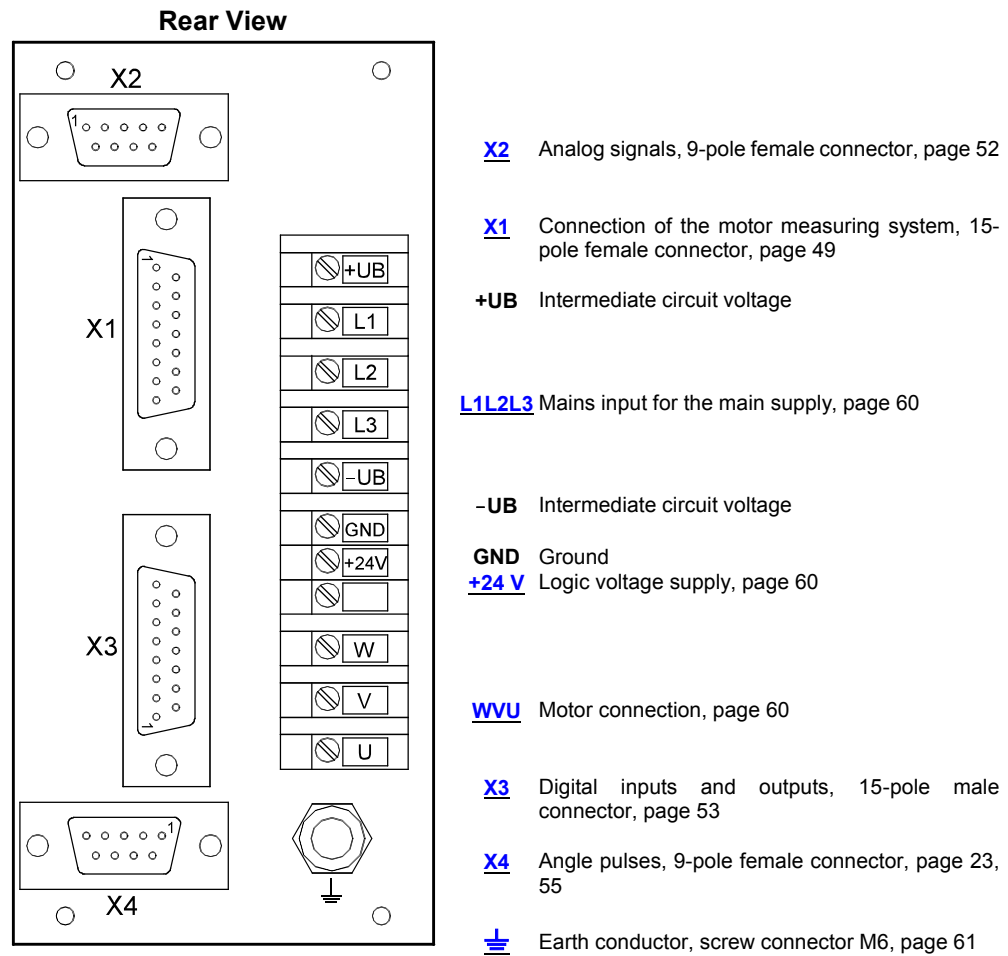

Use a Submin D connector with metal shell as counter connector, so that the shield can directly be connected at the shell.

11.4 Back Plane 36.01.0043.1

Compact amplifier, 12 WU, hinged-frame mounting

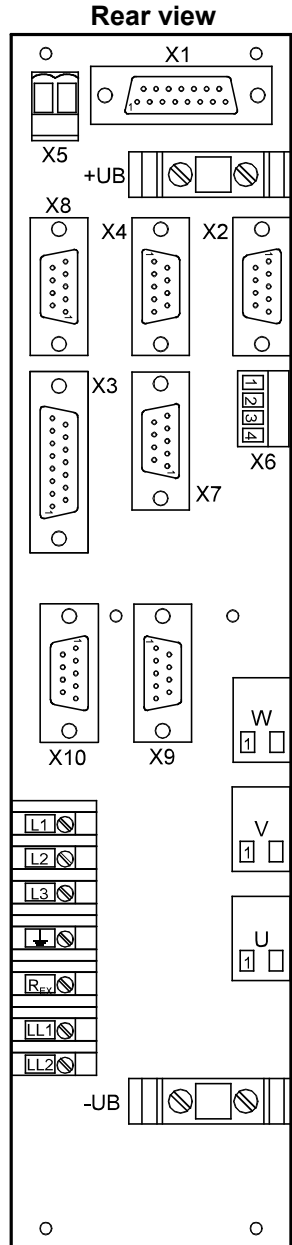

- [X5](#) Thermal contact, page 56
- [X1](#) Connection of the motor measuring system, 15-pole female connector, page 49
- +UB** Intermediate circuit voltage
- [X8](#) COM1, 9-pole female connector, page 58
- [X4](#) Angle pulses, 9-pole female connector, page 23, 55
- [X2](#) Analog signals, 9-pole female connector, page 52
- [X3](#) Digital inputs and outputs, 15-pole male connector, page 53
- [X7](#) Transducer connection, 9-pole female connector, page 58
- [X6](#) Safeguard (option), page 57
- X9** Optional bus system, 9-pole female connector
- X10** Optional bus system, 9-pole male connector
- [WVU](#) Motor connection, page 60
- [L1 L2 L3](#) Mains input for the main supply, page 60
- Earth conductor, page 61
- [R_{EX}](#) External ballast resistor, page 61
- [LL1 LL2](#) Mains input for the logic voltage, page 61
- UB** Intermediate circuit voltage



Use a Submin D connector with metal shell as counter connector, so that the shield can directly be connected at the shell.

11.5 Back Plane 36.01.0044.1

Compact amplifier, 12 TU, wall-mounting

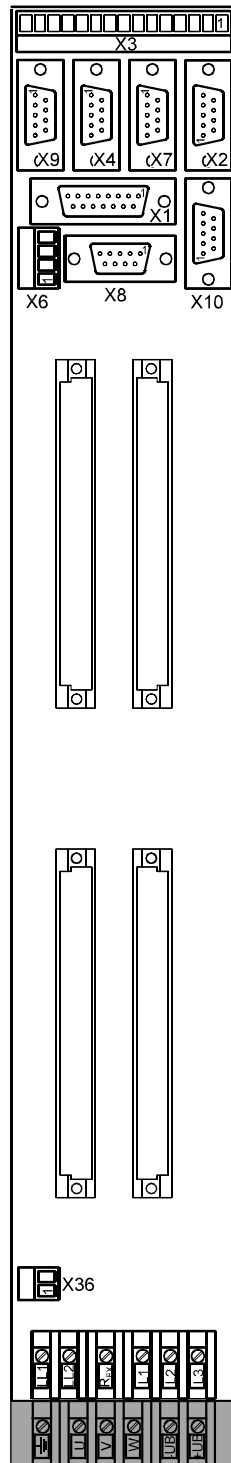

- X3** Digital inputs and outputs, 15-pole PHOENIX Mini CombiCon, page 53
- X9** Optional bus system, 9-pole female connector
- X4** Angle pulses, 9-pole female connector, page 23, 55
- X1** Connection of the motor measuring system, 15-pole female connector, page 49
- X7** Transducer connection, 9-pole female connector, page 58 (usable as from version 36.01.0044.1)
- X2** Analog signals, 9-pole male connector, page 52
- X6** Safeguard, 4-pole PHOENIX Mini CombiCon, page 57
- X8** COM1, 9-pole female connector, page 58
- X9** Optional bus system, 9-pole female connector (Submin D)
- X10** Optional bus system, 9-pole male connector (Submin D)

- LL1 LL2** Mains input for logic voltage, page 61
- R_{EX}** External ballast resistor, page 61
- L1 L2 L3** Mains input for the main supply, page 60

Earth conductor, page 61

UVW Motor connection, page 60

-UB Intermediate circuit voltage
+UB Intermediate circuit voltage



Use a Submin D connector with metal shell as counter connector, so that the shield can directly be connected at the shell.



12 Pin Assignment and Interfaces

12.1 X1 - Connection of the Motor Measuring System

15-pole female Submin D connector

The shield must be connected to the metal shell of the 15-pole male Submin D connector and, if possible, to the respective connector at the motor.

Resolver Evaluation

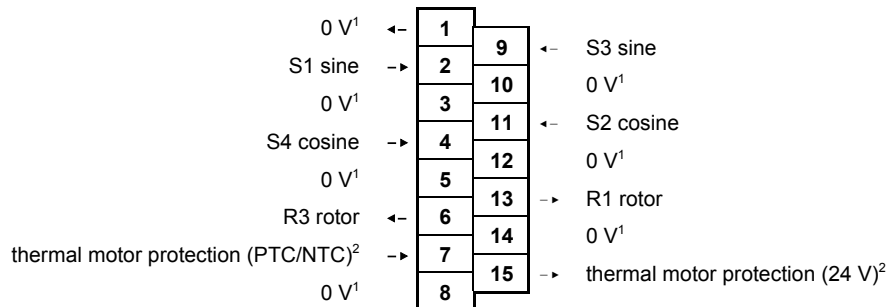

¹ is connected to GND by the servo amplifier

² If no thermal motor protection is connected, pin 15 and pin 7 must be strapped. Consider the connection diagram for the thermal motor protection on page 60.

Use a shielded cable with three pairs of wires, each of which being twisted (e. g. LIYCY 3 × 2 × 0.14). Twist mode: sine/sine; cosine/cosine; rotor/rotor. If the thermal motor protection is evaluated, a shielded twisted pair cable with four pairs of wires must be used.

Connection Diagram

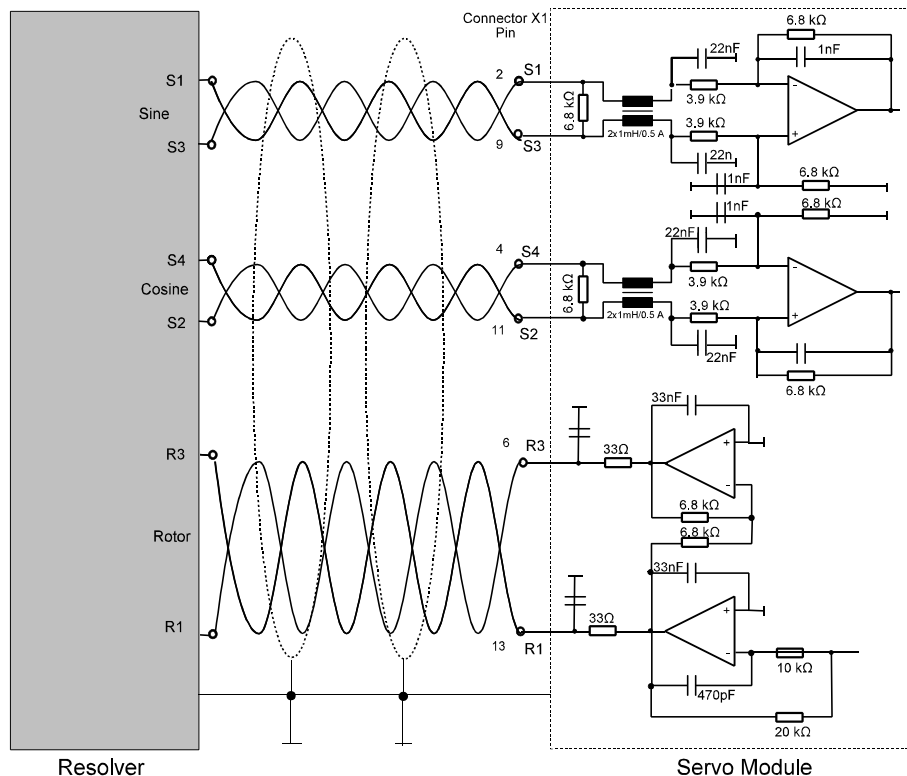



Hall Effect Sensor Evaluation

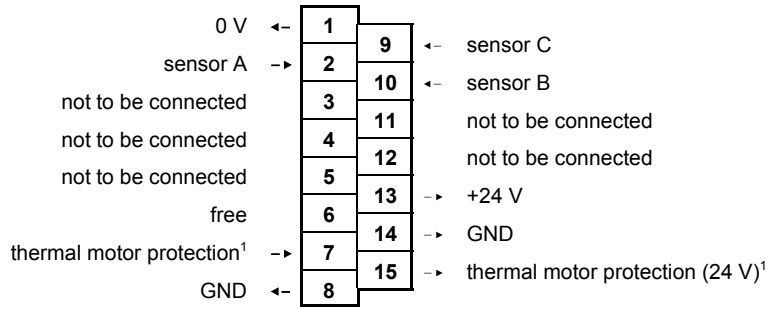

¹ If no thermal motor protection is connected, pin 15 and pin 7 must be strapped.

Connection Diagram

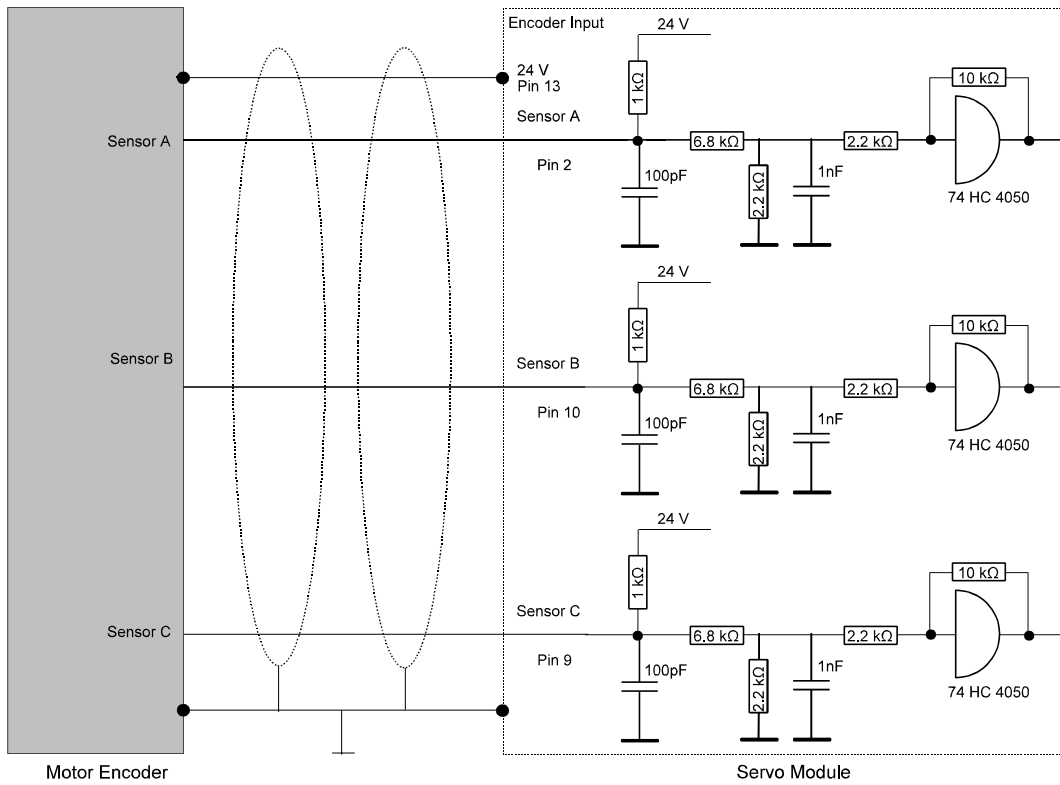

Sine/Cosine Evaluation with optional EnDat-Output

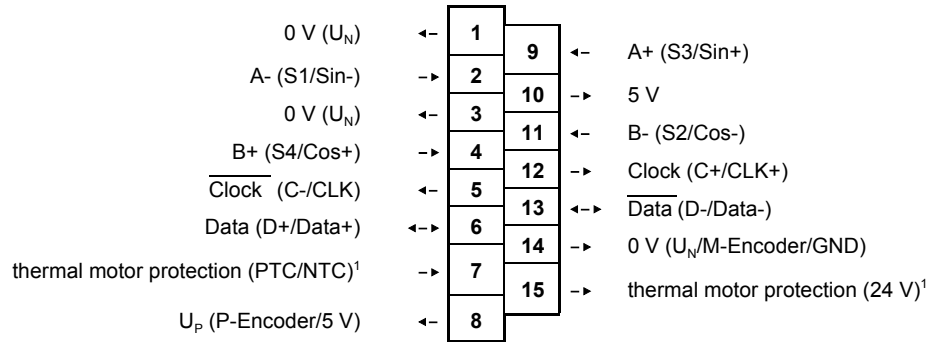

¹ If no thermal motor protection is connected, pin 15 and pin 7 must be strapped.

Connection Diagram

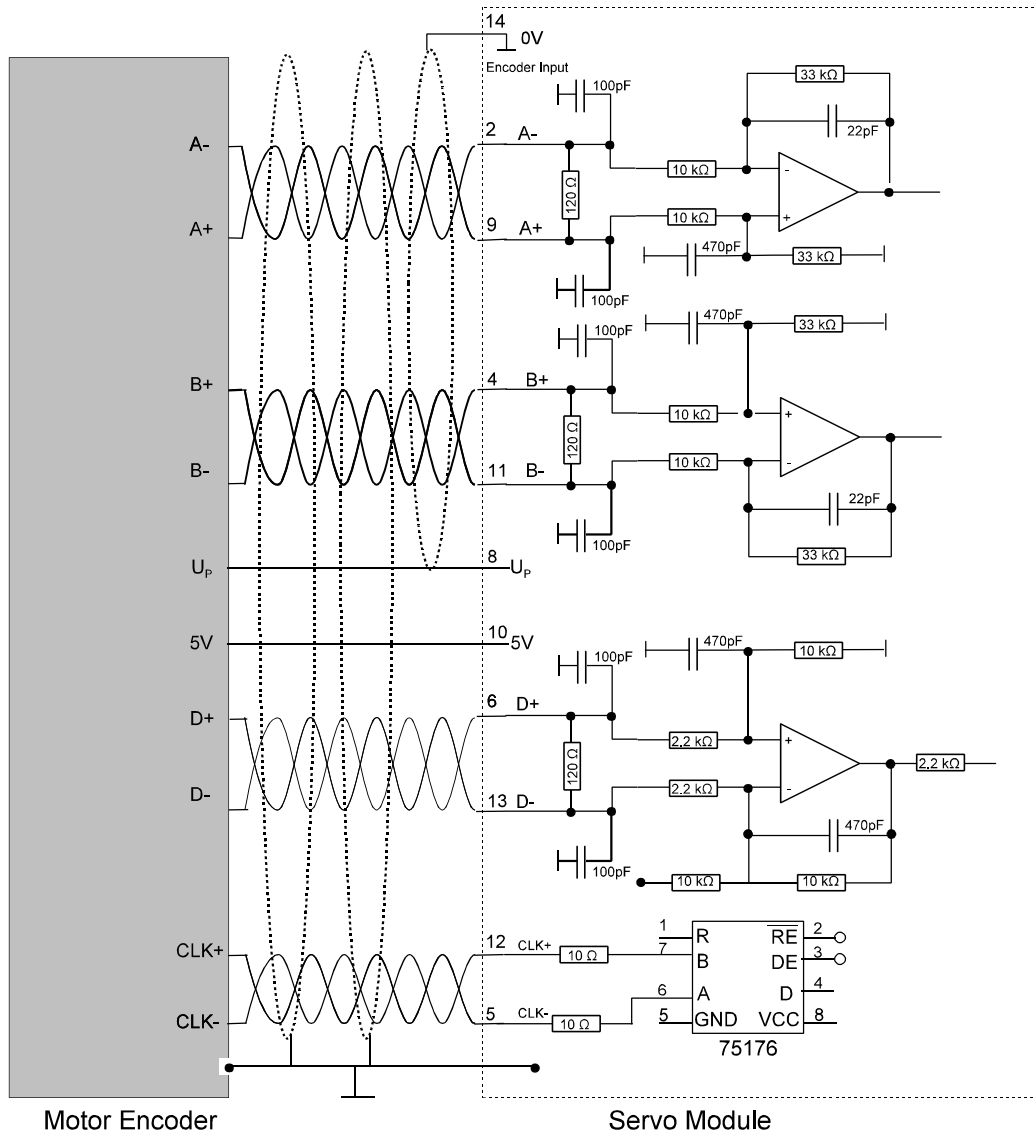

12.2 X2 - Analog Signals

9-pole female Submin D connector

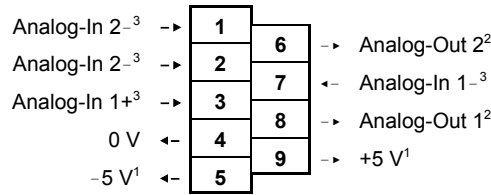

Standard assignment:

- ▶ Analog-In 1⁴: speed reference value
- ▶ Analog-In 2⁴: current reference value
- ▶ Analog-Out 1: tacho
- ▶ Analog-Out 2: actual current value

¹ The voltages should only be used for test purposes! If a shielded cable is used, the shield must be connected single-ended at the metal shell of the 9-pole Submin D connector.

² Outputs 1 and 2. The output signals can be defined in the software (tab page "Devices", branch "Analog Signals").

³ Inputs 1 and 2. The input signals can be defined in the software (tab page "Devices", branch "Analog Signals").

⁴ Differential signal inputs

All **outputs** of the connector X2 can be loaded with a maximum of 10 mA.

Connection Diagram

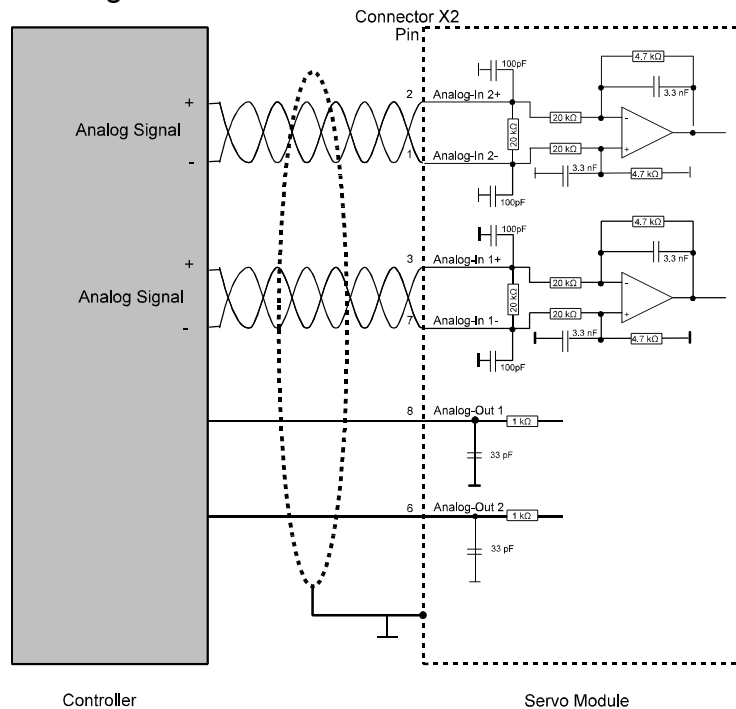

A shielded cable should be used. See manual "Unit Assembly Complying EMC".



If an external current reference value is not preset, the respective analog inputs must be determined as follows: Analog-In+ to +5 V, Analog-In- to -5 V.

12.3 X3 - Digital Inputs and Outputs

The functions of the digital inputs and outputs can be defined in the software. Possible definitions of the [inputs](#), page 63, and the [outputs](#), page 64.

The **outputs** of the connector X3 can be loaded with max. 100 mA. The **inputs** work with a voltage of +14 V to +30 V.



A shielded cable should be used. The shield must be connected single-ended to the metal shell of the connector. See the manual “Unit Assembly Complying EMC”.

12.3.1 15-Pole Male Submin D Connector

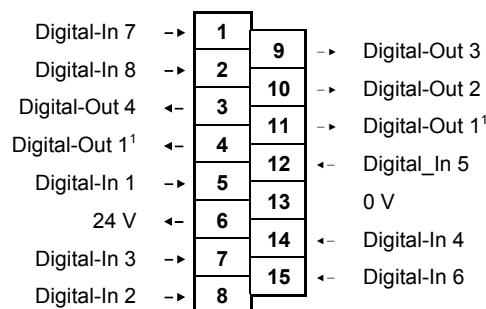

¹ volt-free contacts

12.3.2 15-Pole PHOENIX Mini CombiCon

Pin	I/O	Designation
1	I	Digital-In 7
2	I	Digital-In 8
3	O	Digital-Out 4
4	O	Digital-Out1 ¹
5	I	Digital-In 1
6	O	24 V
7	I	Digital-In 3
8	I	Digital-In 2
9	O	Digital-Out 3
10	O	Digital-Out 2
11	O	Digital-Out1 ¹
12	I	Digital-In 5
13		0 V
14	I	Digital-In 4
15	I	Digital-In6

¹ volt-free contacts



Connection Diagram

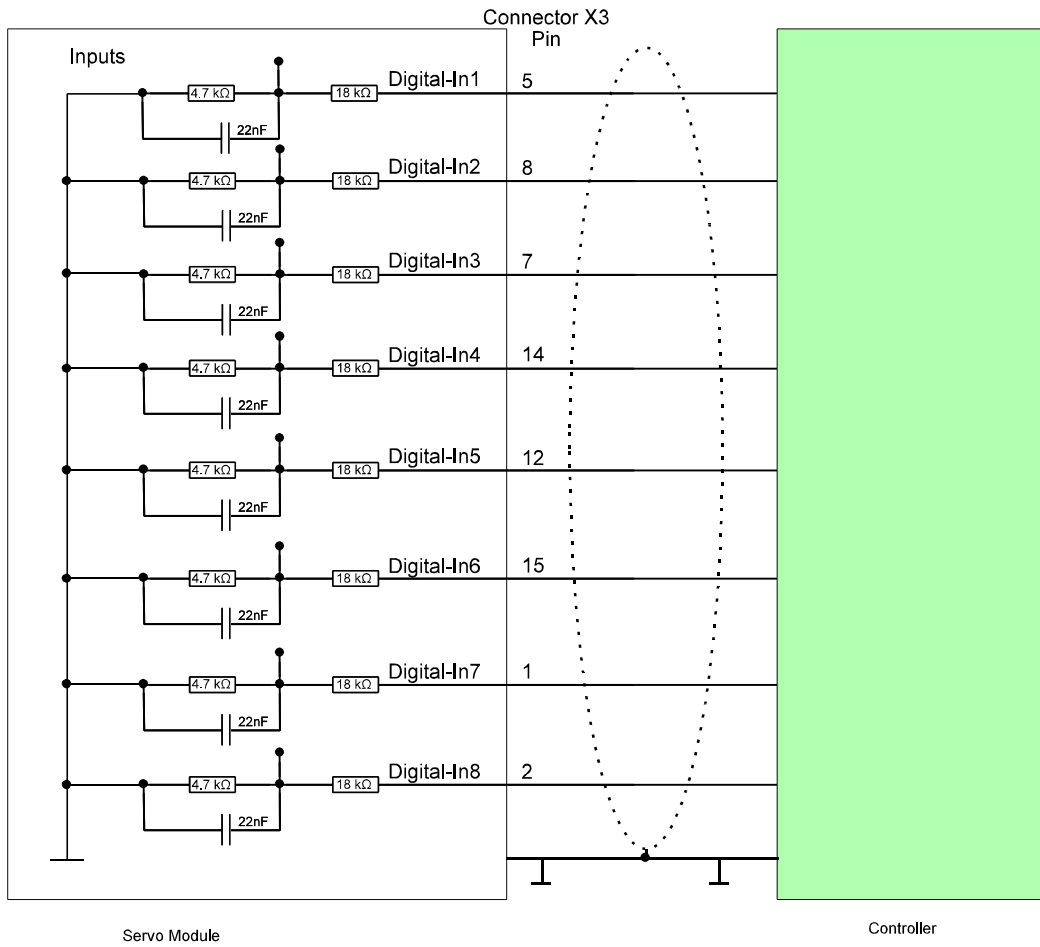

12.4 X4 - Angle Pulses

9-pole female Submin D connector

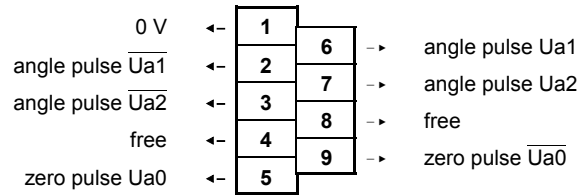

The maximum signal frequency is 1 MHz per track or 4 MHz after quadruplication.



A shielded cable should be used. The shield must be connected single-ended to the metal shell of the 9-pole Submin D connector and to the higher-ranking controller. See the manual "Unit Assembly Complying EMC".

Connection Diagram

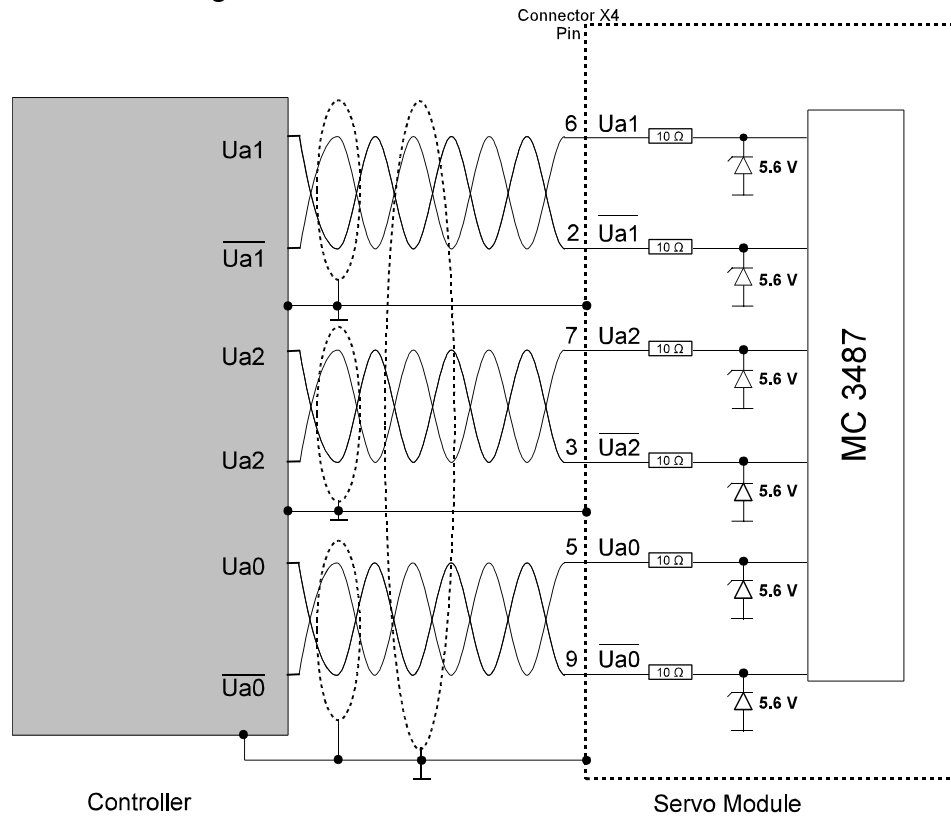

12.5 X5 - Thermal Motor Protection

PHOENIX Mini CombiCon

1	24 V
2	thermal contact

INPUT/OUTPUT: The thermal motor protection is evaluated via these connections.

The servo amplifier supports the evaluation of a temperature monitoring system integrated in the motor. The NTC or PTC behavior of the monitoring system is specified via the software *sinudyn-36* ("motor parameters"). The controller is deactivated as soon as the critical motor temperature is reached.

Connection Diagram

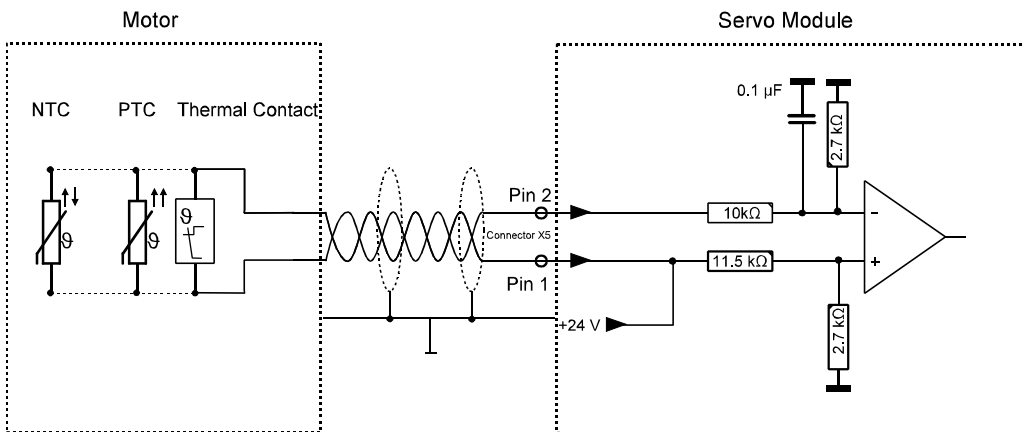

If no thermal motor protection is connected, pin 1 and pin 2 must be strapped.

12.6 X6 - Safeguard (Preventing Unintentional Starts)

✘ In preparation

4-pole PHOENIX CombiCon

Pin	Designation
1	signaling contact safeguard is set -
2	signaling contact safeguard is set +
3	relay - for safeguard
4	relay + for safeguard

See also "[Safeguard](#)", page 67.



12.7 X7 - Transducer

9-pole female Submin D connector

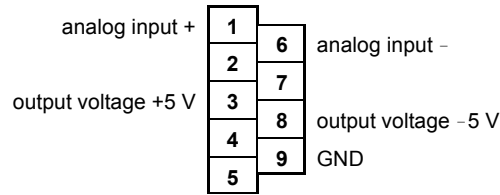

Connection Diagram

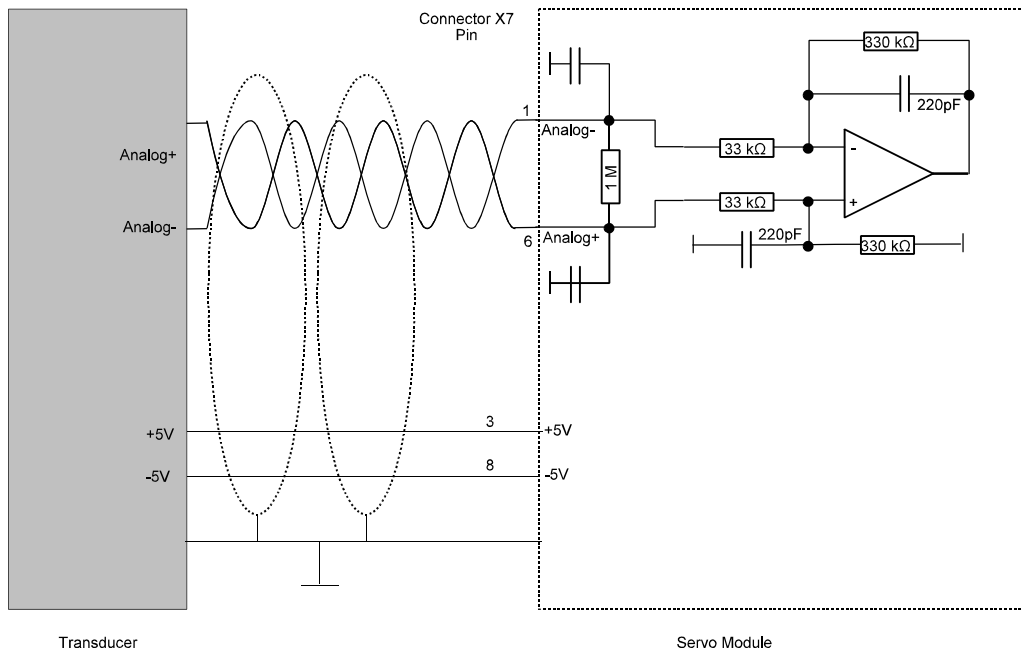

12.8 X8 - COM 1

9-pole female Submin D connector

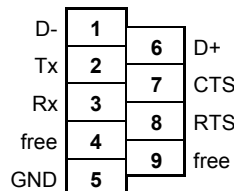

If several servo modules are activated via a serial interface, the position of the ID-coding selector of the single servo modules must be taken into account (see page 60).

12.9 X60 - Power Bus

The 12-pole bus line connects the power module and up to six servo modules. The bus supplies the servo modules with the voltage of +30 V (bus voltage). Status messages of the power module (ready for operation, malfunctions) are also transmitted to the modules. The bus pins of the power module are outputs, while the bus pins of the servo modules are inputs. Additionally, the 12-pole bus provides +5V/GND, which are isolated and which can be loaded with up to 1.8 A. The 5 V can also be adjusted precisely by means of the potentiometer +5 V MSY at the front panel of the power module.

Pin	I/O	Assignment	
1	O	+5 V	
2	O	GND	
3 + 4	O	earth potential	
5	O	POK	
6	O	overvoltage signal	
7	I	+24 V	
8	---	not assigned	
9 + 10	O	+30 V	mains potential
11 + 12	O	0 V for the 30 V	mains potential

I = input
O = output



The +30 V must not be used for any other purposes.

Mains OK

This output activates and deactivates, inter alia, the servo modules. If the main supply is not provided, the signal "mains OK" will be LOW and the servo modules cannot be activated. The user may use this signal via the contacts [BB](#) at the power modules 26.50.65 and 26.50.88.

Overvoltage signal

If an overvoltage comes up, the level of 24 V drops to 0 V. Then the regulator of the servo module is deactivated (contact *POK* at the power modules 26.50.65 and 26.50.88). Error messages are kept.

12.10 S1 - ID-coding selector

Standard = servo module address 0

If several servo modules are activated via a RS232/485 bus system, a specific address must be assigned to each servo module via the ID-coding selector (0 to F). Each address must only be assigned once (see also *sinudyn-36* Software Description, Chapter "Select Servo Module Address").



12.11 U / V / W - Motor Connections

W	W
V	V
U	U

12.12 L1, L2, L3 - Mains Input for the Main Supply

PHOENIX clamp-type connectors

The intermediate circuit voltage of the compact amplifier is generated by the main voltage supply *L1, L2, L3*.

Connector	3-Phase Operation	1-Phase Operation
L1	phase L1	phase L1
L2	phase L2	neutral conductor
L3	phase L3	---



The discharge time of the intermediate circuit is 2 minutes after turning off the mains inputs *L1, L2, L3*. Then the potential of the intermediate circuit is approx. 40 V_{DC}. The logic voltage supply at the input +24 V therefore need not to be provided.

Protection of the compact amplifiers, see page 27.

12.13 +24 V - Logic Supply

PHOENIX connector

✘ Only Back Panel 36.01.0042

30 V are generated via the logic supply of 24 V_{DC} and the integrated step-up converter inside the compact amplifier. A DC/DC converter then generates the internal system voltage supply of +24 V and ±5 V independently of the main supply.

The tolerance for the input voltage +24 V_{DC} may be ±20 %.





The wiring must be carried out in a way that the logic supply is activated before the main supply is turned on.

12.14 LL1, LL2 - Eingänge für die Logikeinspeisung

PHOENIX clamp-type connectors

✘ Only Back Panels 36.01.0043 and 36.01.0044.1

Independently of the main supply, the logic supply causes that the intrasystem logic is ready for operation **before** turning on the main supply L1, L2, L3. Now, all signals and messages are available to the user.

Compact Amplifier	Compact Amplifier
<ul style="list-style-type: none"> ▶ 36.03.10xx ▶ 36.03.11xx 	<ul style="list-style-type: none"> ▶ 36.03.13xx ▶ 36.03.14xx
The logic supply LL1/LL2 is connected to the same potential as the main supply L1/L2.	The logic supply LL1/LL2 is connected to +24 V/GND. The tolerance for the input voltage of +24 V _{DC} can be ±20 %.
 LL1 ≙ L1 LL2 ≙ L2	 LL1 = + 24 V LL2 = GND



The inputs LL1 and LL2 must always be connected. The angle pulses and error messages are kept in case of an **EMERGENCY STOP** situation. If the main supply is turned off, make sure that all three mains phases are also turned off. Consequently, a main contactor with positively driven contacts must be used.

12.15 Earth Conductor

The earth conductor \perp (PE) is connected via the screw connector M6.

12.16 R_{EX} - External Ballast Resistor

PHOENIX clamp-type connector

During the generator operation the motor feeds energy back into the intermediate circuit. If the intermediate circuit voltage has reached a specific potential, the ballast resistor will be switched into the intermediate circuit via a transistor to dissipate the surplus energy.



Consider that the values of the ballast resistors to be used must not fall below the minimum values. You will find the minimum values in chapter 5 "Technical Data", page 25 ff.



13 Digital Inputs and Outputs

13.1 Specification of the Inputs and Outputs

The functions of the inputs and outputs can be defined in the software. See “*sinudyn-36* Software Description”.

13.1.1 Inputs

The inputs can be defined in both operational modes as described in the tables.

Operational Mode: Nut Setting

Connector X3/ Pin	Input	Possible Assignment	Description
5	Digital-In 1	No function	No function is executed
8	Digital-In 2	No function	No function is executed
		Emergency stop	Stopping input (LOW active): The speed ref. value is internally decelerated to zero. Afterwards the drive is held controlled in position (drift-free).
		Speed enable	Stopping input (LOW active): The speed ref. value is internally set to zero. The speed controller is operated as P controller.
7	Digital-In 3	Parameter record 1	Parameter record for nut runner start
		Parameter record 1/2	Parameter record for nut runner start
14	Digital-In 4	No function	No function is executed
		Parameter record 2	Parameter record for nut runner start
12	Digital-In 5	No function	No function is executed
15	Digital-In 6	Nut runner start	The regulator is activated. The selected program is executed.
1	Digital-In 7	No function	No function is executed
		Parameter record 3	Parameter record for nut runner start
2	Digital-In 8	No function	No function is executed
		Parameter record 4	Parameter record for nut runner start



Operational Mode: Servo

Connector X3/ Pin	Input	Possible Assignment	Description
5	Digital-In 1	Regulator On	The regulator is activated, and the speed ref. value is enabled. When deactivating, the speed ref. value is internally decelerated to zero and the regulator is deactivated.
		Regulator On without deceleration	The regulator is activated, and the speed ref. value is enabled. When deactivating, the regulator is deactivated without decelerating the motor.
8	Digital-In 2	No function	No function is executed
		Emergency stop	Stopping input (LOW active): The speed ref. value is internally decelerated to zero. Afterwards the drive is held controlled in position (drift-free).
		Speed enable	Stopping input (LOW active): The speed ref. value is internally set to zero. The speed controller is operated as P controller.
7	Digital-In 3	No function	No function is executed
		Limit switch -	Stopping input (LOW active) for the negative speed ref. value: The speed ref. value is internally set to zero. Afterwards the drive is held controlled in position.
		Limit switch - only P amplifier	Stopping input (LOW active) for the negative speed ref. value: The speed ref. value is internally set to zero. The drive is operated as P controller.
		Limit switch - with deceleration	Stopping input (LOW active) for the negative speed ref. value: The speed ref. value is internally decelerated to zero. Afterwards the drive is held controlled in position.
14	Digital-In 4	No function	No function is executed
		Limit switch +	Stopping input (LOW active) for the positive speed ref. value: The speed ref. value is internally set to zero. Afterwards the drive is held controlled in position.
		Limit switch + only P amplifier	Stopping input (LOW active) for the positive speed ref. value: The speed ref. value is internally set to zero. The drive is operated as P controller.
		Limit switch + with deceleration	Stopping input (LOW active) for the negative speed ref. value: The speed ref. value is internally decelerated to zero. Afterwards the drive is held controlled in position.
12	Digital-In 5	No function	No function is executed
		P amplifier	The speed controller is operated as P controller. That means: The integral action gain is set to zero.
		Direction of rotation	The speed ref. value is inverted.
15	Digital-In 6	No function	No function is executed
		P amplifier	The speed controller is operated as P controller. That means: The integral action gain is set to zero.
		Direction of rotation	The speed ref. value is inverted.
		User-specific function 1	---
		Current/speed control	Change-over between speed-controlled and the torque-controlled operation.
1	Digital-In 7	No function	No function is executed
		P amplifier	The speed controller is operated as P controller. That means: The integral action gain is set to zero.
		Direction of rotation	The speed ref. value is inverted.
2	Digital-In 8	No function	No function is executed
		P amplifier	The speed controller is operated as P controller. That means: The integral action gain is set to zero.
		Direction of rotation	The speed ref. value is inverted

13.1.2 Outputs

The outputs can be defined in both operational modes as described in the tables.



Operational Mode: Nut Setting

Connector X3/ Pin	Output	Possible Assignment	Description
4 and 11	Digital-Out 1	No function	No function is executed
		Regulator OK	The servo amplifier is ready for operation. No error has occurred at the unit.
		PI limit	The speed controller is in its limitation. The preset torque has been reached.
10	Digital-Out 2	No function	No function is executed
		PI limit	The speed controller is in its limitation. The preset torque has been reached.
9	Digital-Out 3	No function	No function is executed
		PI limit	The speed controller is in its limitation. The preset torque has been reached.
		Nut setting OK	The selected nut setting cycle has been executed correctly.
3	Digital-Out 4	No function	No function is executed
		Nut setting NOK	The selected nut setting cycle was faulty.



Operational Mode: Servo

Output / Connector / Pin	Possible Assignment	Description
Digital-Out 1 / X3 / 4 + 11 Digital-Out 2 / X3 / 10 Digital-Out 3 / X3 / 9 Digital-Out 4 / X3 / 3	No function	No function is executed
	Regulator OK	The servo amplifier is ready for operation. No error has occurred at the unit.
	PI limit	The speed controller is in its limitation. The preset torque has been reached.
	$ Nerr < x$	The absolute value of the speed window is within a predefined window.
	$ Nerr > x$	The absolute value of the speed window is beyond a predefined window.
	$ Nact < x$	The absolute value of the actual speed is within a predefined window.
	$ Nact > x$	The absolute value of the actual speed is beyond a predefined window.
	$ Iact < x$	The absolute value of the actual current value is within a predefined window.
	$ Iact > x$	The absolute value of the actual current value is beyond a predefined window.
	$I^*t < x$	The I^*t capacity of the unit is below a predefined threshold.
	$I^*t > x$	The I^*t capacity of the unit is above a predefined threshold.
	DC_LINK < x	The measured intermediate circuit voltage is below a predefined threshold.
	DC_LINK > x	The measured intermediate circuit voltage is above a predefined threshold.
	User-specific function 0	---
Activation of motor brake	Activation signal for a motor brake	

14 Safeguard (Preventing Unintentional Start)

✘ according to EN 945-1 category 3

The safeguard prevents the unintentional start of a variable-speed motor in the standstill and can, for example, be used in the machine function “safe hold”.

The standstill of the machine must have been initiated via an external machine controller and, assurance must be given that the speed reference value input signals the speed reference value Zero. The safeguard disrupts the energy supply between drive and motor by deactivating the output stage control. Thus, any rotation of the motor is impossible.



The safeguard does not galvanically separate the output stages from the motor. Thus, it does not protect against electric shock.



The complete machine must always be galvanically separated from the mains with the main switch (DIN EN 60204-1 5.3) for any interruptions of the operation, maintenance, repair or cleaning work at the machine or system.

14.1 Safeguard Function

The safeguard locks the respective drive of a rack. Any other drive modules remain in proper condition.

A positively driven relay has access to the respective output stage activation of the drive to be locked and interrupts the connection. Thus, no control signals can be passed on to the output stage transistors.

A positively driven n/o contact of the safeguard relay (signaling contact safeguard) must be latched as acknowledgment contact with a higher-ranking fail-safe control system or signaling unit. The signaling contact of the safeguard must separate the drive from the mains via the main contactor in the main supply in case of a safeguard failure, which means: The safeguard is set, but the signaling contact remains opened. Without this additional wiring (redundancy), the safety category 3 according to EN 945-1 cannot be met.

The relay of the safeguard must only be activated, if

- the drive is safely be decelerated,
- the CNC module is deactivated and
- the holding brake of the motor has been arrested.

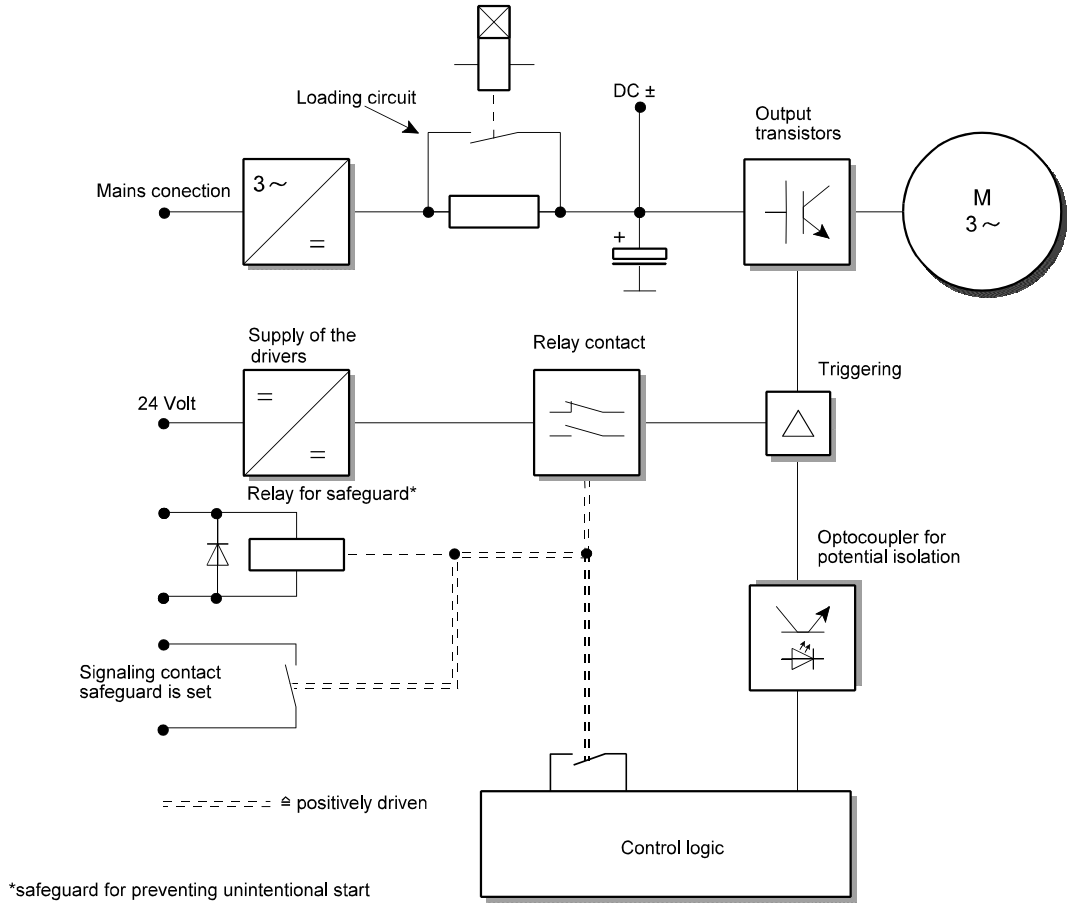

Block Diagram of the Safeguard



The motor cannot provide a torque, if the safeguard is active. Non-self-locking drives as well as hanging loads must be fixed with a mechanical brake.

The wiring has the advantage that a separate drive can be locked, while other drives are in duty.

14.2 Exemplary Wiring

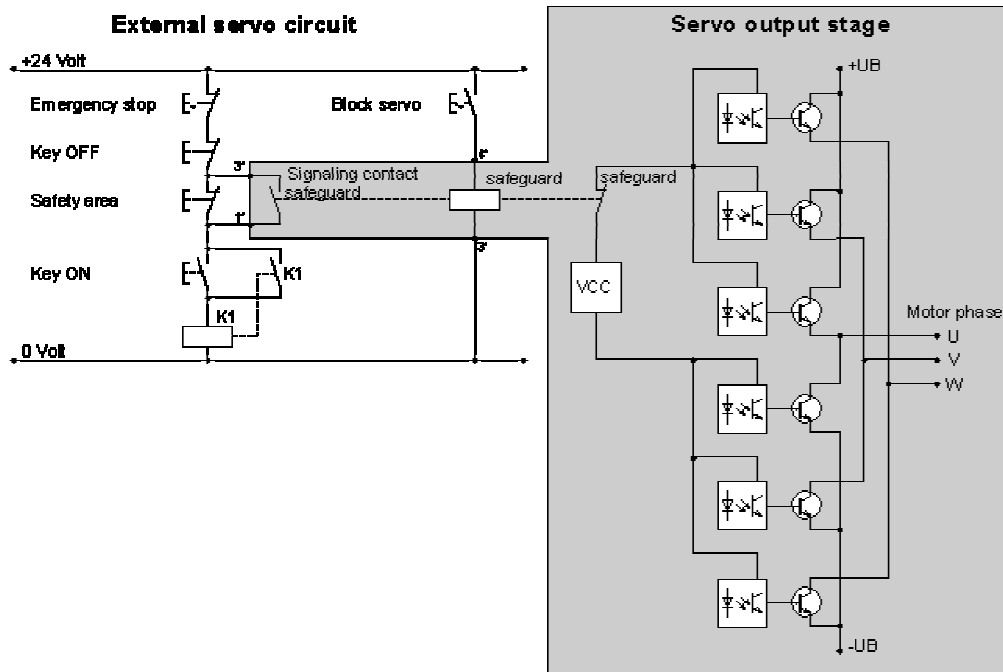

Exemplary wiring

*Pins of the connector "safeguard" on the back planes 36.01.xxxx.



Without an additional redundancy (evaluation of the signaling contacts), the safety category 3 according to EN 945-1 cannot be met.



The contacts of the safeguard for preventing unintentional start are positively driven. The used relay meets the safety regulations and is accepted by the TÜV Rheinland organization (Germany) and is conform to EN 50205-2003-1 (relay with positively driven contacts) as well as to UL and CSA.



15 Front Panel

15.1 Multi-Axis Servo Amplifier

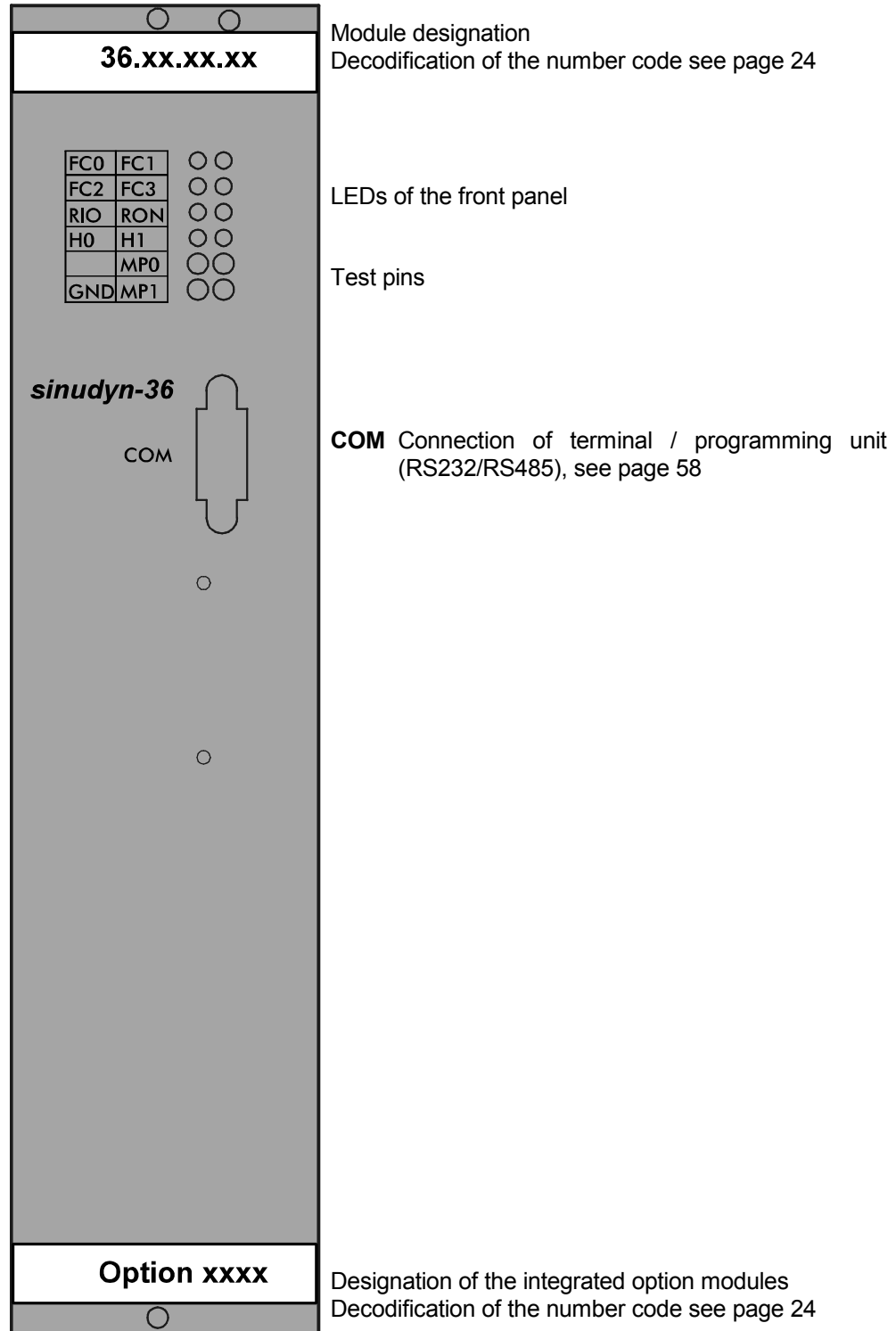

15.2 Compact Amplifiers

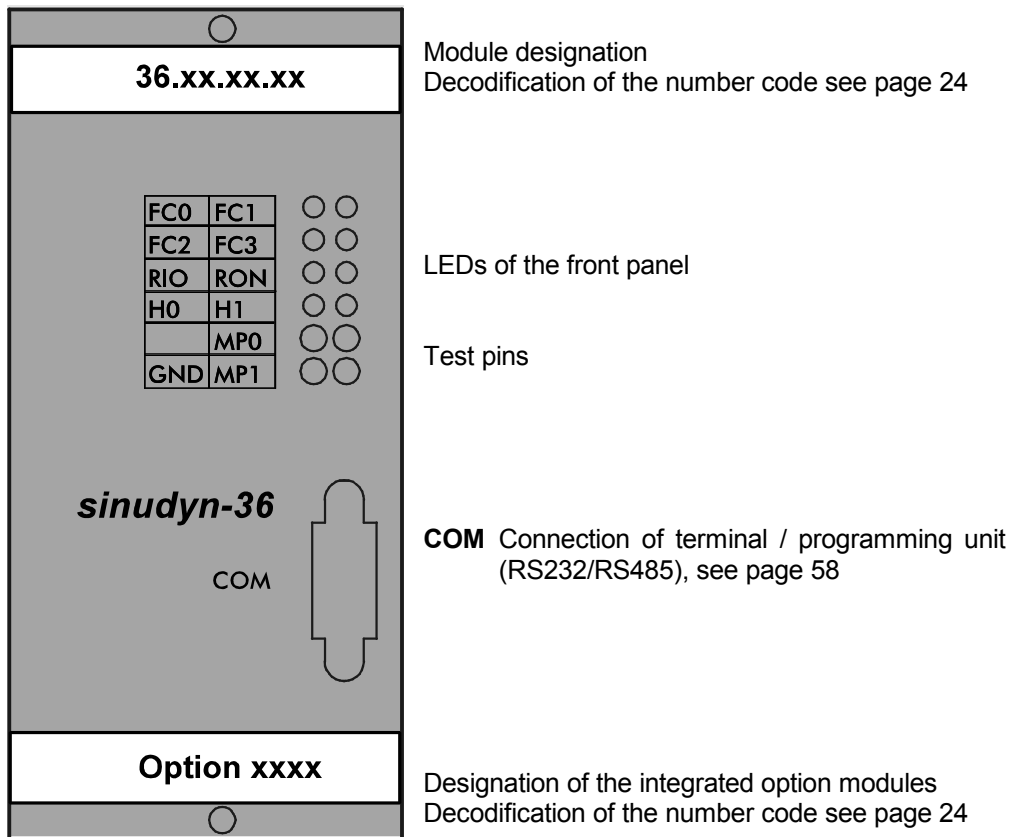

15.3 Test Pins

The test pins at the front panel of the servo module enable the user to receive basic data of the drive system.

Arrangement of the LEDs and test pins

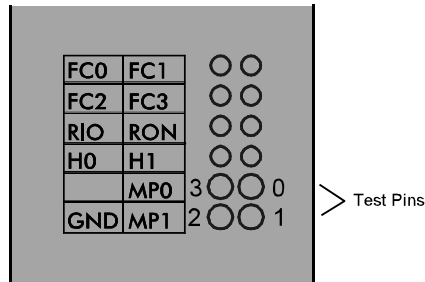

Test Pins	Meaning
0	Freely assignable within the programming of the PCsoftware (see "sinudyn-36 Software Description").
1	Freely assignable within the programming of the PCsoftware (see "sinudyn-36 Software Description").
2	Ground = 0 V reference point for measuring purposes
3	Ground = 0 V reference point for measuring purposes

15.4 Indication of the Front Panels

15.4.1 Status Indication *RON*

LED <i>RON</i>	Significance
○	output stage is locked
●	output stage is enabled

15.4.2 Status Indication *RIO*

LED <i>RIO</i>	Significance
○	drive identifies an error (see “Error Messages” , page 75)
●	no error

15.4.3 Status Indication *H0/H1*

When using an optional communication module the yellow shining LEDs indicate the status.

LED <i>H0/H1</i>	Meaning
○	no communication module connected
●	communication module connected

15.4.4 Messages

Messages are indicated by the green shining LED *FC0*, *FC1*, *FC2* and *FC3*. Every LED is assigned to a respective message. Max. four messages can be indicated simultaneously.

Status LED	Message	Reaction
○ ○ ○ ○	no	no
● ○ ○ ○	speed controller is in limitation	no
○ ● ○ ○	emergency stop	the reaction can be preset in the software, see “Digital Inputs and Outputs” , page 63
○ ○ ○ ●	negative limit switch	the reaction can be preset in the software, see “Digital Inputs and Outputs” , page 63
○ ○ ● ○	positive limit switch	the reaction can be preset in the software, see “Digital Inputs and Outputs” , page 63

15.4.5 Error Messages

Errors are indicated by the red shining LEDs **FC0**, **FC1**, **FC2** and **FC3**. If an error message is indicated,

- ▶ flashing
the respective error has induced the turnoff of the drive
- ▶ continuously,
just an error message is indicated, inducing no reaction.

An error, inducing the turnoff of the unit, can be reset with a positive edge at the input *Regulator ON*. The error message for the deactivated regulator must not be acknowledged.

An error code is assigned to every error message, so that always the error with the highest error code is evaluated and indicated.

Error		Number	Description	Reaction
Message				
		F01	mains supply is not OK	the drive decelerates with the parameter EMERGENCY RAMP and is then deactivated
		F02	motor temperature (NTC / PTC)	the drive decelerates 100 ms and is then deactivated
		F03	heatsink temperature	the drive decelerates 100 ms and is then deactivated
		F05	I ² t monitoring	the drive decelerates 100 ms and is then deactivated
		F06	overspeed	the drive is immediately deactivated
		F07	error of the motor measuring system	the drive is immediately deactivated
		F09	motor phases not OK	the drive is immediately deactivated
		F11	undervoltage DC_LINK	the drive is immediately deactivated
		F12	overvoltage DC_LINK	the drive is immediately deactivated
		F13	overcurrent output stage	the drive is immediately deactivated
		F14	power module is not OK	the drive cannot be activated
		F15	parametrizing error	the drive cannot be activated

- LED is not on
- ◐ LED flashes
- LED is on



16 Layout Plans

16.1 Layout Plan of the logic 36.01.0021.3

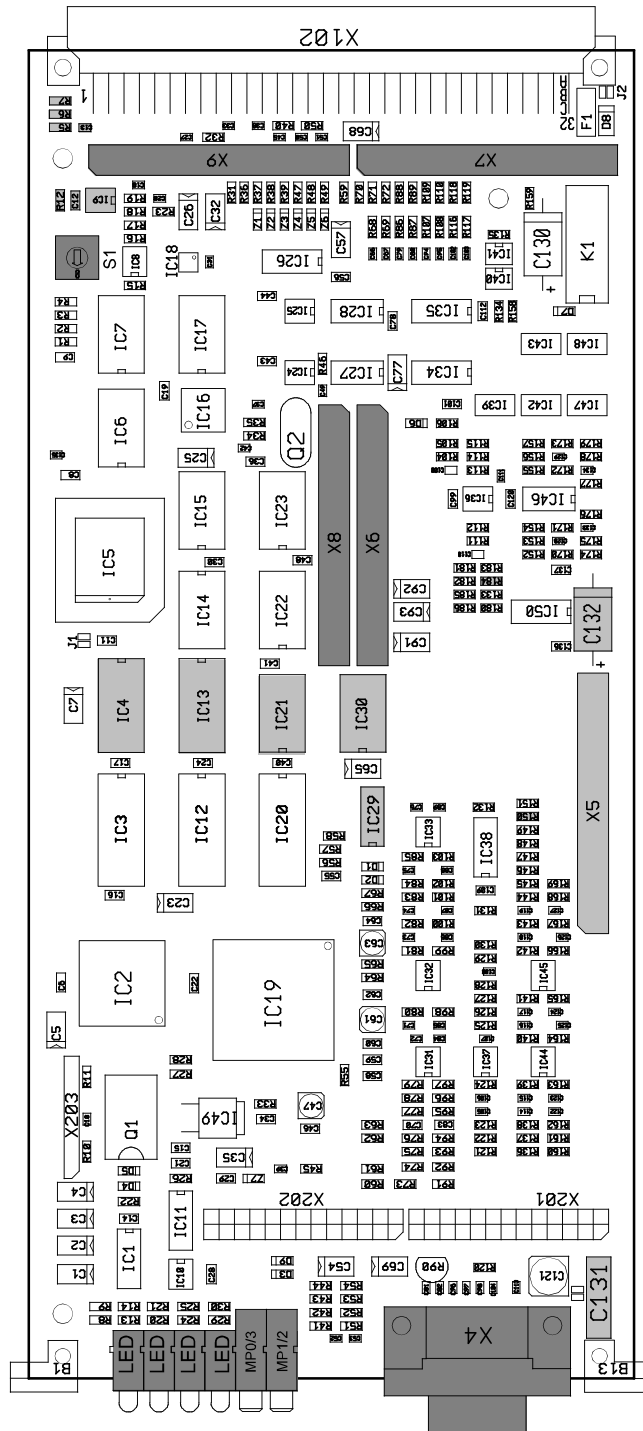

Designation	Meaning	Designation	Meaning
LEDs 1 to 8	Status indication	X6 and X7	Slots for the reference value module
MP 0 to 3	Test pins	X8 and X9	Slots for the sensor module
X4	COM, Connection of the terminal / programming unit	S1	Coding selector for the selection of the servo module address
X5	Slot for the optional communication module, equipped acc. to the variant		

The components marked in light grey are equipped according to the variant.

16.2 Compact Power Module for the Servo Amplifiers 36.03.10 and 36.03.11

- ▶ Logic supply 115 V_{AC} to 230 V_{AC}
- ▶ Main supply 115 V_{AC} to 230 V_{AC}

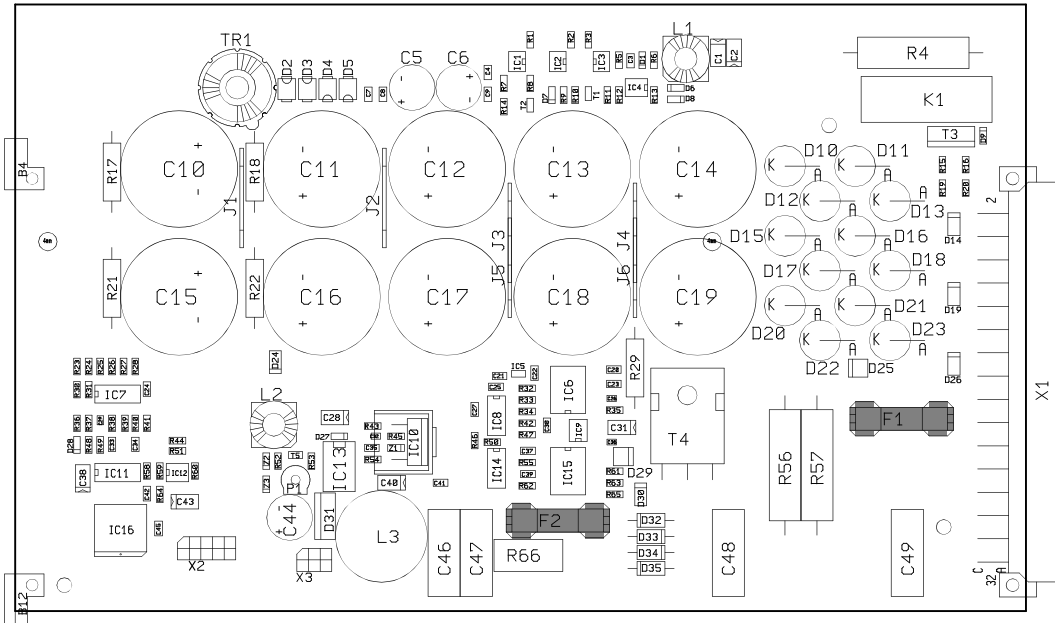

Designation	Function
F1	Fuse for the internal ballast circuit (2A, semi time-lag fuse). If an external ballast resistor is used, the fuse F1 must be removed.
F2	Fuse for the logic supply (1A, semi time-lag fuse).

16.3 Compact Power Module for the servo amplifiers 36.03.13 and 36.03.14

- ▶ Logic supply 24 V_{DC}
- ▶ Main supply 34 V_{DC} to 480 V_{DC}

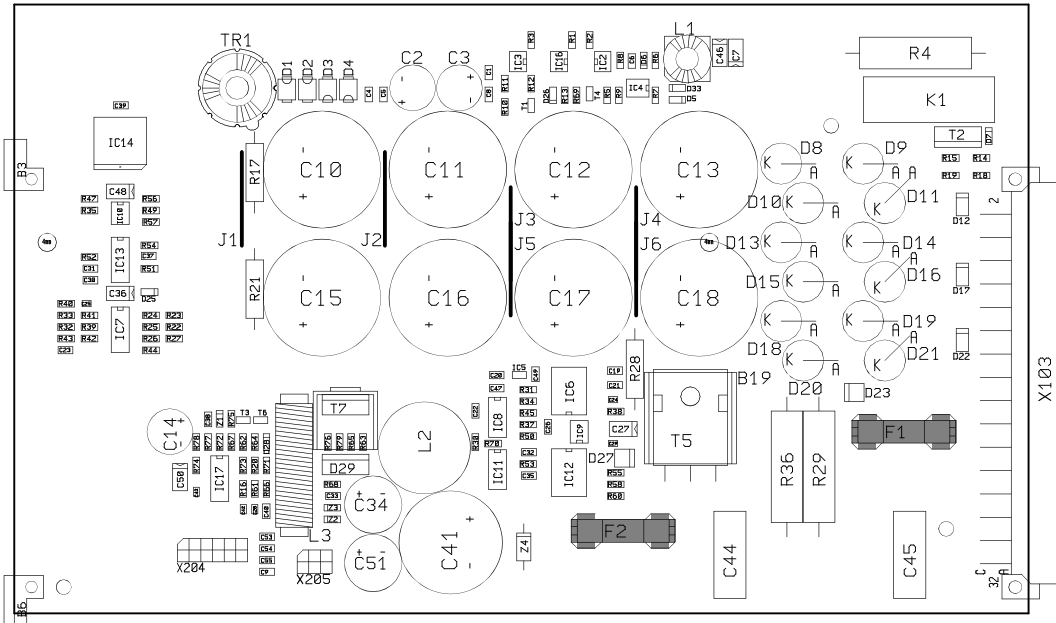

Designation	Function
F1	Fuse for the internal ballast circuit (1.6 A, semi time-lag fuse). If an external ballast resistor is used, the fuse F1 must be removed.
F2	Fuse for the logic supply (2 A, semi time-lag fuse).



Appendix

17 Electric Performance Dimensioning

Experience shows that questions arise during the dimensioning of a drive when selecting output stages and power supplies. This chapter shall make clear the physical background and shall help to correctly dimension the electronic components.

17.1 Components

17.1.1 Output Stage

The output stage of a servo amplifier is specified by the following details:

Voltage Range

The maximum intermediate circuit voltage is limited by the used transistors and capacitors and the minimum space between the circuit-board conductors.

Components have an electric strength of $600 V_{DC}$ at output stages with a max. admissible intermediate circuit voltage of $325 V_{DC}$ (class C), that means: at an AC supply of $230 V_{AC}$. The reserve is necessary to preclude damages at surge voltages and to protect the higher intermediate circuit voltages during the deceleration.

Current Range

The current range specifies the max. admissible currents. Distinction is made between peak and rated current:

- The **peak current** is only admissible for a short time (mostly 5 seconds) and depends on the used transistors and their number.
- The **rated current** can be provided continuously by the output stage. Its value depends on the cooling of the transistors, that means: the capacity of the used heatsink and its ventilation.

17.1.2 Power Supply

The power supply is specified by the following details:

Voltage Range

The maximum voltage supply is limited by the used transistors, diodes and capacitors and the minimum space between the circuit-board conductors.

Current Range

The current range specifies the max. admissible currents. Distinction is made between peak and rated current:

- ▶ The **peak current** is only admissible shortly (mostly 1 second) and depends on the used diodes and their number.
- ▶ The **rated current** can be provided continuously by the power supply. Its value depends on the cooling of the diodes, that means: the capacity of the used heatsink and its ventilation.

Capacity

In practice, a maximum permanent power is specified, since the supply voltage is assumed to be constant. Since the limitation in the power supply is determined by the load carrying capacity of the diodes, the maximum permanent power depends on the supply voltage and the type of supply.

Examples:

Supply 230 V_{AC}, 2 phases, max. permanent current of diodes 6 A
 $230V_{AC} \times 2 \times 6 A = 2.76 kW$

Supply 400 V_{AC}, 3 phases, max. permanent current of diodes 6 A
 $400V_{AC} \times 3 \times 6 A = 7.20 kW$

The maximum peak current depends on the diode type.

The **protection** is calculated as follows:

$$\frac{\text{Capacity}}{\text{Supply}} = \frac{2,76kW}{230V_{AC}} = 12A_{r.m.s}$$

17.1.3 Motor

Among other things, the motor is specified by the following details:

Peak Current

The peak current defines the max. admissible motor current. The peak current is only admissible for short times (between 1 and 30 seconds) and depends on the used motor material and the thickness of the coil wires. The motor manufacturer normally specifies the peak current for standstill and the rotating field. Normally, the specifications are r.m.s. values.

Rated Current

The rated current can permanently impressed to the motor. Its value depends on the motor cooling, the coils and the max. admissible motor temperature. The motor manufacturer normally specifies the rated current for standstill and the rotating field. Normally, the specifications are r.m.s. values.

Voltage Constant

Due to the underlying inductance, the motor generates during the operation a negative field voltage, which is opposite to the provided voltage. This voltage is proportional to the speed and is specified in volt per 1,000 revolutions. The specifications are normally r.m.s. values and are measured between the connection terminals.

Example:

Intermediate circuit voltage: 325 V, e.m.f.: 100 V /1,000 revs.

Only 225 V are provided per 1000 RPM for controlling the motor. The motor has the theoretical max. speed of 3,250 RPM. At this speed no torque is provided, since a current cannot be impressed.

Torque Constant

The torque constant specifies the ratio between the motor current and the motor torque (Nm/A). The torque constant is the result of required the max. speed, the dynamics, the efficiency and the quality of the magnet material.

Inductive Coil Resistance

The inductive coil resistance (ωL) results from the number of windings of the coil. It is zero during the standstill. The resistance increases with the frequency.

Ohmic Coil Resistance

The ohmic coil resistance R results from the length and thickness of the wires. During the standstill only it specifies the coil resistance.

Electric Time Constant

The electric time constant results from the ohmic and the inductive resistance ($\tau = L/R$)

Nut Setting Motors

Nut setting motors usually are high dynamic, with high peak speed, high peak torque, low mass inertia and low rated torque. As a result, the voltage constant and inductance are low, the wires of the coil are thin and the rotor diameter is small. Due to the low inductance, nut setting motors are operated with a high pulse width modulation (PWM frequency 16 kHz) to keep the current ripple low.

17.2 Power Consumption of a Drive

If a constant torque is taken from the drive, the power consumption will depend on the actual speed.

Examples:

Preset torque:	30 Nm
Intermediate circuit voltage:	300 V
Voltage constant:	50 V / 1,000 RPM
Coil resistance:	1 Ω
Torque constant:	1 Nm / A

From this results a motor current of

$$I = \frac{30\text{Nm}}{1\text{Nm / A}} = 30\text{A}$$

The motor requires a voltage of $U = 1 \Omega \times 30 \text{ A} = 30 \text{ V}$

0 RPM, Standstill

From this results a power of $P = 30 \text{ V} \times 30 \text{ A} = 0.9 \text{ kW}$

At an intermediate circuit voltage of 300 V an input current results from the supply voltage of $I = P / 300 \text{ V} = 3 \text{ A}$

Thus, in the power supply considerably less current flows than in the motor. This reflection is very important especially for nut setting applications, since the high torques and currents are only required for low speeds.

2,000 RPM

At 2,000 RPM the motor requires a voltage of $U = R \times I + e.m.f. \times n = 1 \Omega \times 30 \text{ A} + 50 \text{ V} / (1,000 \text{ RPM}) \times (2,000 \text{ RPM}) = 130 \text{ V}$.

From this results a power of $P = 130 \text{ V} \times 30 \text{ A} = 3.9 \text{ kW}$.

At an intermediate circuit voltage of 300 V an input current results from the supply voltage of $I = P / 300 \text{ V} = 13 \text{ A}$.

In the power supply thus a considerable higher current flows at 2,000 RPM than at standstill.

5,400 U/min

At 5,400 RPM the motor requires a voltage of $U = R \times I + e.m.f. \times n = 1 \Omega \times 30 \text{ A} + 50 \text{ V} / (1,000 \text{ RPM}) \times (5,400 \text{ RPM}) = 300 \text{ V}$.

From this results a power of $P = 300 \text{ V} \times 30 \text{ A} = 9 \text{ kW}$.

At an intermediate voltage of 300 V an input current results from the supply voltage of $I = P / 300 \text{ V} = 30\text{A}$.

The identical current value thus flows in the power supply at 5,400 RPM than in the motor.

It must be considered, that the currents, flowing in the motor phases, are lower by factor $\sqrt{3}$ than the currents, calculated above.

The examples clearly show that the expected motion profile must be considered for the dimensioning of the power module. An exact dimensioning is only possible by integrating the motion profile.

This also applies for the dimensioning of the output stage and the motor.

18 **Appendix: Revisions**

The appendix describes alterations, made in comparison to the version with the identification number "036-servo-tec-sinudyn36/R001-sm-de-hp/ca" of December 3rd, 2001.

**Identification number "036-servo-tec-sinudyn36/R002-sm-de-hk/ca/ac"
of April 9th, 2002**

Completely revised.

**Identification number "036-servo-tec-sinudyn36/R003-sm-de-hk/ca/ac"
of November 29, 2002**

Completely revised.

The following alterations are worth mentioning:

- | | |
|------------|--|
| Page 23 | Section 6.2: The figures showing the modules for wall mounting and front connection have been exchanged. |
| Page 27 | In the table, section 7.2.2, the value for the minimum ballast resistor has been changed. |
| Page 31 | Section 8.1: The dimensioned drawing has been added. |
| Page 44 | Section 11.2: The back plane 36.01.0046 has been added. |
| Page 49 ff | Connection diagrams have been added to the descriptions of the connectors. |
| Page 61 | Section 12.16: The warning notice has been added. |
| Page 74 | Section 15.4.3 "Status Indication H0/H1" has been added. |
| Page 77 ff | Chapter 16 "Layout Plans" has been added. Specifications of the fuses have been added. |

