



DIAX04 HVE and HVR 2nd Generation Power Supply Units Application Manual

SYSTEM200

Title	DIAX04 HVE and HVR 2nd Generation Power Supply Units
Type of documentation	Application Manual
Document typecode	DOK-POWER*-HVE+HVR**G2-AW05-EN-P
Internal file reference	<ul style="list-style-type: none"> Document Number, 120-1900-B301-05/EN
Purpose of documentation	<p>The purpose of this documentation is to</p> <ul style="list-style-type: none"> choose and calculate the power supply unit for the drive controllers types DIAX04 (HDD and HDS), which is appropriate for your applications. plan the construction of the control cabinet. mount and connect the power supply units.

Record of revisions

Description	Release Date	Notes
DOK-POWER*-HVE+HVR**G2-ANW1-EN-P	06.98	first edition
DOK-POWER*-HVE+HVR**G2-ANW2-EN-P	09.98	Revision
DOK-POWER*-HVE+HVR**G2-AN03-EN-P	03.99	Revision
DOK-POWER*-HVE+HVR**G2-AW05-EN-P	09.00	Revision

Copyright © 2000 Rexroth Indramat GmbH

Copying this document, giving it to others and the use or communication of the contents thereof without express authority, are forbidden. Offenders are liable for the payment of damages. All rights are reserved in the event of the grant of a patent or the registration of a utility model or design (DIN 34-1).

Validity All rights are reserved with respect to the content of this documentation and the availability of the product.

Published by Rexroth Indramat GmbH
 Bgm.-Dr.-Nebel-Str. 2 • D-97816 Lohr a. Main
 Telephone +49 (0) 93 52/40-0 • Tx 689421 • Fax +49 (0) 93 52/40-48 85
<http://www.rexroth.com/indramat>
 Dept. ECD (SA/HK)

Note This document has been printed on chlorine-free bleached paper.

Supplementary documentation

Note: The following documentation is not required in its entirety for the correct use of the power supply units HVR and HVE.

Title	Type of documentation	Document typecode	Material number
AC Drive Units in Hazardous Areas (Expl. Protection)	Instructions for Use	DOK-GENERL-ANTR*EXPLOS-ANxx-EN-P	266 304
AC Drive Units in Personnel Conveyor Systems	Instructions for Use	DOK-GENERL-ANTR*PERSON-ANxx-EN-P	266 305
Electromagnetic Compatibility (EMC) in Drive and Control Systems	Project Planning Manual	DOK-GENERL-EMV*****-PRJ*-EN-P	259 814
List of Connecting Cables for DIAX04 and ECODRIVE 03	Selection Lists	DOK-CONNEC-CABLE*STAND-AUxx-EN-P	282 688
DIAX03/04, ECODRIVE03 AC-Hauptantriebe mit 2AD- und ADF-Motoren / AC main drives with 2AD- and ADF-motors	Auswahldaten / Selection data	DOK-DRIVE*-MAIN*WZM***-AU01-MS-P	289 233
DIAX04 Servoantriebe 2. Generation / Servo drives 2nd Generation	Auswahldaten / Selection lists	DOK-DIAX04-SERV*****G2-AUxx-MS-P	281 668
DIAX04 AC-Antriebe für Dauerbetrieb (S1)	Auswahldaten / Selection lists	DOK-DIAX04-PRIN*****-AUxx-MS-P	286 052
Asynchronous Linear Motors LAF	Selection Data DIAX03 / DIAX04	DOK-MOTOR*-LAF*****-AUxx-EN-P	277 353
DIAX04 HDD and HDS Drive Controllers 2nd Generation	Project Planning Manual	DOK-DIAX04-HDD+HDS**G2-PRxx-EN-P	280 446
DIAX04 Plug-in modules for digital intelligent drive controllers	Project Planning Manual	DOK-DIAX04-PLUG*IN*MOD-PRxx-EN-P	275 156

Fig.: Supplementary documentation

Changes from previous version

Note: The following list may not be absolutely complete. The author reserves the right to make changes to this list as needed.

Where?	What?
	Supplementary documentation inserted
General Safety Guidelines	update
Mains Switch Control	Indicating the maximum admissible resistance of the Emergency Stop chain
Technical Data, Mounting, electrical connection	HZF filter included
	Choke data corrected
Auxiliary Components	Description HZK included
Auxiliary Components	Description HZB included
	Lost heat: Example calculation added
	Use in accordance with the requirements added
	New structure of the system overview
Entire Document	New layout of the formula representation
HVR	Terminal diagram updated
HVR/HVE	Power terminal diagram updated
HVE	Mains connection updated
KD	Technical data and unit dimensions corrected
GLD	Technical data and unit dimensions corrected
Interfaces for System Control	Chapter newly structured

Fig.: Alterations with regard to the previous version
DOK-POWER*-HVE+HVR**G2-AW03-EN-P

Contents

1	System overview	1-1
1.1	Rexroth Indramat AC drive system	1-1
1.2	Principal working mode of the power supply units	1-2
1.3	Areas of application	1-3
1.4	Overview of the unit features	1-4
2	Important directions for use	2-1
2.1	Appropriate use	2-1
	Introduction	2-1
	Areas of use and application	2-2
2.2	Inappropriate use	2-2
3	Safety Instructions	3-1
3.1	Introduction	3-1
3.2	Explanations	3-1
3.3	Hazards by inappropriate use	3-2
3.4	General Information	3-3
3.5	Protection against contact with electrical parts	3-4
3.6	Protection by protective low voltage (PELV) against electrical shock	3-6
3.7	Protection against dangerous movements	3-6
3.8	Protection against magnetic and electromagnetic fields during operations and mounting	3-8
3.9	Protection against contact with hot parts	3-9
3.10	Protection during handling and installation	3-9
3.11	Battery safety	3-10
3.12	Protection against pressurized Systems	3-10
4	Technical data	4-1
4.1	Power supply units HVE	4-1
4.2	Power supply unit HVR	4-5
4.3	Commutation choke KD	4-8
4.4	Combining filter HZF	4-8
5	Determination of appropriate power supply units	5-1
5.1	Introduction	5-1
5.2	DC bus continuous power	5-1
5.3	DC bus peak power	5-4
5.4	Regenerated energy	5-5
5.5	Continuous regenerated power	5-6

5.6	Peak regenerated power.....	5-7
5.7	Connected load of the power supply unit.....	5-8
5.8	Using the control voltage.....	5-8
6	Auxiliary components	6-1
6.1	DC bus choke GLD.....	6-1
6.2	Additional capacitance module HZK.....	6-2
	Dimensioning and unit arrangement.....	6-2
	Front view.....	6-3
	Unit dimensions.....	6-4
6.3	Additional bleeder module HZB.....	6-4
	Front view.....	6-7
	Unit dimensions.....	6-8
7	Mounting	7-1
7.1	Control cabinet planning.....	7-1
	Conditions of use.....	7-1
	Loss of heat in the control cabinet.....	7-2
7.2	Mounting an HVE or HVR into the control cabinet.....	7-8
7.3	Optimal EMC installation.....	7-11
	HVE.....	7-11
	HVR.....	7-12
7.4	Dimensional data.....	7-13
	HVE02.2 and HVE03.2.....	7-13
	HVE04.2.....	7-14
	HVR.....	7-15
	HZF01.1-W010N.....	7-16
	HZF01.1-W025N / HZF01.1-W045N.....	7-17
	Commutation choke KD xx.....	7-18
7.5	Mounting the unit.....	7-19
8	Electrical connection	8-1
8.1	Introduction.....	8-1
8.2	Front view and terminal diagram.....	8-2
	HVE.....	8-2
	HVR.....	8-5
	HZF.....	8-7
8.3	Mains connection.....	8-8
	General.....	8-8
	HVE.....	8-9
	HVR.....	8-12
8.4	Fusing with direct mains supply.....	8-15
8.5	Grounding the power supply system.....	8-17
8.6	Connecting drive controllers to the power supply unit.....	8-17
	Arranging the units horizontally.....	8-17
	Arranging the units vertically.....	8-18

8.7	Fault current protective device	8-20
8.8	Earth leakage monitor	8-20
8.9	Interference elimination	8-21
8.10	Control cabinet check	8-22
9	Control mains contactor	9-1
9.1	Control possibilities	9-1
	Shutdowns with faulty drive electronics	9-1
	Braking with emergency stop or power failure	9-1
9.2	Controlling the power supply unit with emergency stop relays	9-1
	With DC bus dynamic brake	9-1
	Without DC bus dynamic brake	9-4
9.3	Control via NC controller	9-6
10	Interfaces for system control	10-1
10.1	DC bus dynamic brake	10-1
10.2	Control voltages	10-3
10.3	Controlling auxiliary components	10-3
10.4	Acknowledging the power supply unit mains contactor	10-4
	"Acknowledge power ON"	10-4
	"Acknowledge power OFF"	10-4
10.5	Ready-to-operate and other messages	10-5
	Ready-to-operate (Bb1)	10-6
	Power supply in order (UD)	10-6
	Pre-warning (VW)	10-6
	Bleeder pre-warning contact (BVW)	10-6
	Chronological sequence when switching on and off	10-7
11	Troubleshooting	11-1
11.1	General	11-1
11.2	Fault diagnostics and resetting faults	11-1
11.3	Checking and repairing the unit	11-2
11.4	Replacing the unit	11-3
11.5	Diagnostic Display	11-4
	Overview	11-4
	Description, possible cause and troubleshooting	11-5
12	Service & Support	12-1
12.1	Helpdesk	12-1
12.2	Service-Hotline	12-1
12.3	Internet – World Wide Web	12-1
12.4	Vor der Kontaktaufnahme ... - Before contacting us	12-1
12.5	Kundenbetreuungsstellen - Sales & Service Facilities	12-2
13	Index	13-1

1 System overview

1.1 Rexroth Indramat AC drive system

The AC drive system, has been developed by us in a modular design so that the performance and functionality of the drives will meet your application requirements. Furthermore, it is possible for you to operate several drive controllers on one power supply unit; that is, every drive system, consisting of the power supply unit and drive and control system(s), needs only one mains connection.

This documentation describes the power supply unit types HVE and HVR from the DIAX04 family.

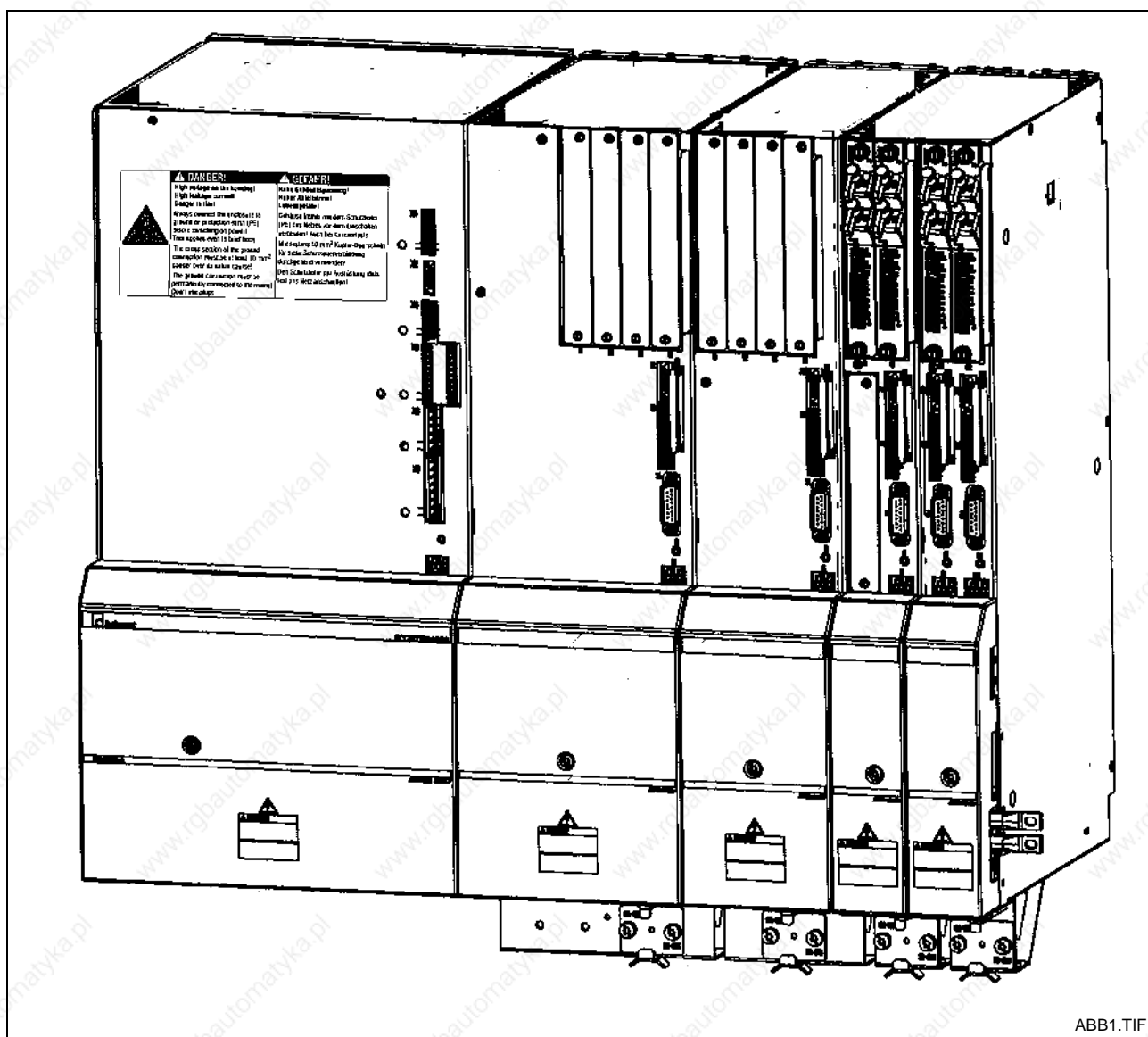

Fig. 1-1: Exemplary structure of a modular Rexroth Indramat AC drive system

1.2 Principal working mode of the power supply units

Rectification The 3-phase AC voltage is rectified by the power rectifier of the power supply units HVR and HVE.

The HVR power supply units provide a regulated DC bus voltage whereas the HVE power supply units provide an unregulated DC bus voltage for the drive controllers.

Generative operation When using a HVE power supply unit and running in generator mode the regenerated energy is dissipated as heat via a bleeder resistor.

When using a HVR power supply unit and running in generator mode the energy is regenerated back into the mains.

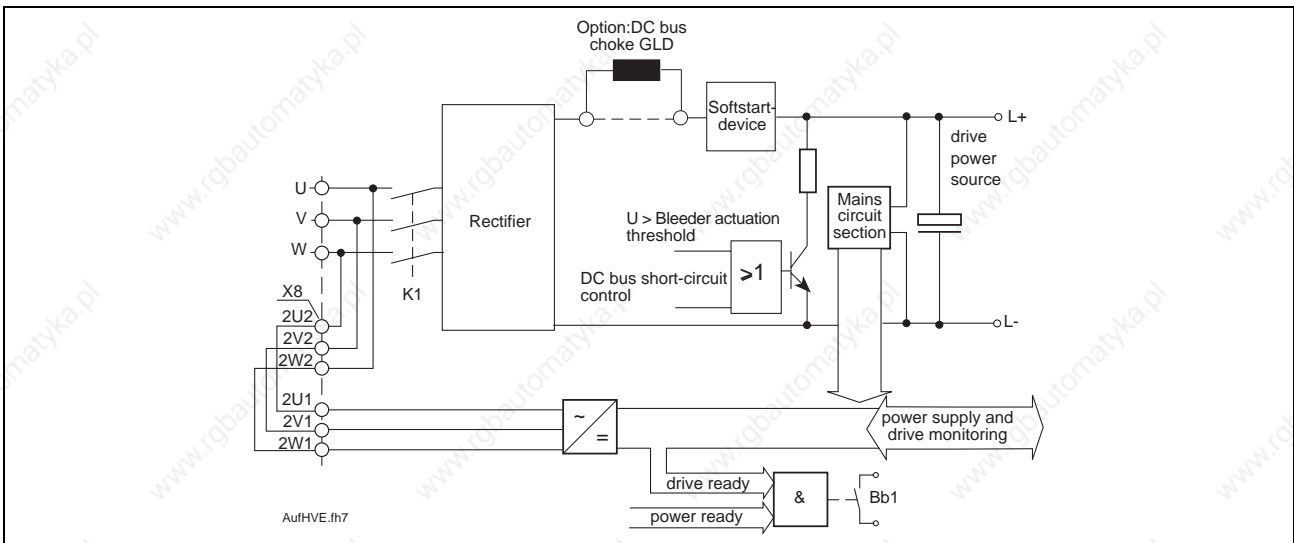

Fig. 1-2: Structure of the HVE power supply unit

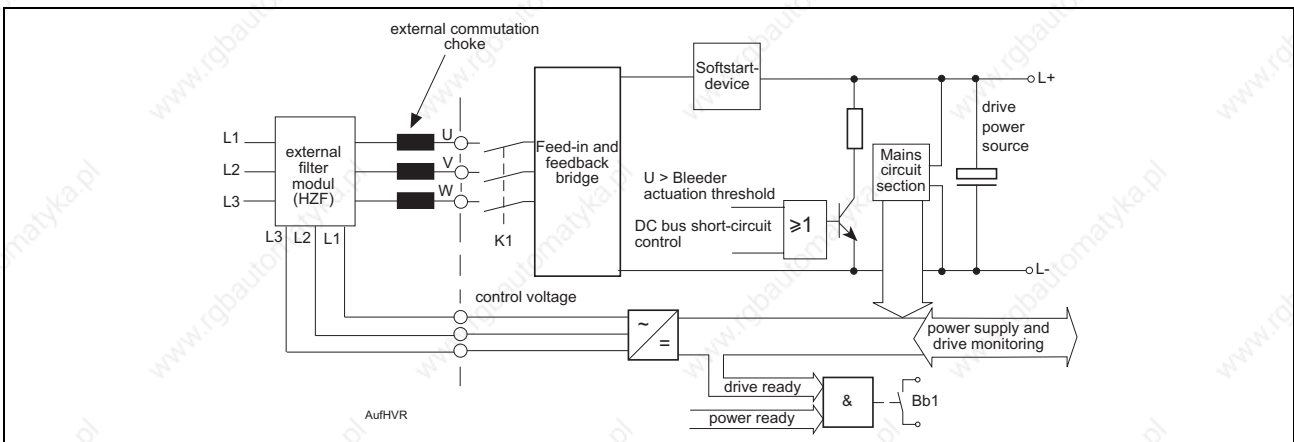

Fig. 1-3: Structure of the HVR power supply unit

Shutdown	<p>With both power supply unit types, motors with permanent magnet energizing can be braked by the short-circuit bus also in the event of a fault in the drive electronics.</p> <p>In the event of a mains failure or shut down power supply unit, motors are braked controlled by the bleeder in the HVR.</p> <p>Due to the internal power contactor of the power supply units, the drive controllers can be separated from the mains.</p>
Control voltage supply	<p>HVR and HVE provide the control voltage for all connected drive controllers.</p> <p>In the case of a mains failure, the control voltage will be provided by the DC bus voltage of the power supply unit. In regenerative mode the drive electronic remains fully operational, supplied by the DC bus voltage.</p>
Monitoring of the drive system	<p>HVR and HVE are equipped with substantial monitoring functions. The power supply units communicate with the drive controllers via the control bus voltage.</p> <p>Most important for the functionality of the drive systems is the Bb1 contact. Once closed, the internal power contactor can be connected.</p>

1.3 Areas of application

HVR and HVE power supply units can be connected to mains voltages consisting of 3 x AC 380 ... 480 V. They are necessary for the power and control voltage supply by Rexroth Indramat drive and control system types HDD and HDS.

Motors of a maximum continuous mechanical power of 36 kW are connected to the HVR power supply units, motors of a maximum of 60 kW can be connected to HVE power supply units.

1.4 Overview of the unit features

Direct mains connection	HVE and HVR power supply units can be connected to 3 x AC 380 ... 480 V \pm 10 %, 50 ... 60 Hz power systems without the need for transformers.
Small space requirements	The high DC bus voltage permits small unit dimensions with high unit performance.
Contactor integrated into unit shuts down power	A contactor is integrated into power supply unit which shuts down the power supply.
High ON time in brake mode possible	In the case of HVR power supply units, the energy created when braking the drives is fed back into the mains with little loss.
Optimum matching of the power requirements to an application	Power supply units of the HVE and HVR line are available in six variations. This means that the power supply can be optimally adapted to a specific application.
Regulated DC bus voltage	Power supply units of the HVR line are working with regulated DC bus voltage, i. e. drive dynamics do not drop with undervoltage.
High short-term operating load	Triple output can be generated short-term to accelerate the drives.
Safety even with faulty drive electronics	Motors with permanent magnetic excitation can be braked by unit's internal DC bus dynamic brake in the event of a fault in the drive electronics.
Charging current limits	Due to unit integrated capacitors, the energizing current does not have to be considered when the control units are chosen for the power supply. The service life of the control units is prolonged.
High load capabilities of the control voltage	Several drive modules can be connected to one power supply unit.
Ease of servicing	The connection of the signal lines is effected via plug-in terminals. The power supply units include an alphanumeric display. This display serves for diagnostics and makes it possible to clear faults more easily.

2 Important directions for use

2.1 Appropriate use

Introduction

Rexroth Indramat products represent state-of-the-art developments and manufacturing. They are tested prior to delivery to ensure operating safety and reliability.

The products may only be used in the manner that is defined as appropriate. If they are used in an inappropriate manner, then situations can develop that may lead to property damage or injury to personnel.

Note: Rexroth Indramat, as manufacturer, is not liable for any damages resulting from inappropriate use. In such cases, the guarantee and the right to payment of damages resulting from inappropriate use are forfeited. The user alone carries all responsibility of the risks.

Before using Rexroth Indramat products, make sure that all the prerequisites for an appropriate use of the products are satisfied:

- Personnel that in any way, shape or form uses our products must first read and understand the relevant safety instructions and be familiar with appropriate use.
- If the product takes the form of hardware, then they must remain in their original state, in other words, no structural changes are permitted. It is not permitted to decompile software products or alter source codes.
- Do not mount damaged or faulty products or use them in operation.
- Make sure that the products have been installed in the manner described in the relevant documentation.

Areas of use and application

HVE and HVR power supply units are exclusively used to supply electricity to drive controllers of the DIAX04 product family (HDS and HDD drive controllers).

Control and monitoring of the motors may require additional sensors and actors.

Note: The power supply units may only be used with the accessories and parts specified in this document. If a component has not been specifically named, then it may not be either mounted or connected. The same applies to cables and lines.

Operation is only permitted in the specified configurations and combinations of components using the software and firmware as specified in the relevant function descriptions.

The power supply units may only be operated under the assembly, installation and ambient conditions as described here (temperature, system of protection, humidity, EMC requirements, etc.) and in the position specified.

2.2 Inappropriate use

Using the power supply units outside of the above-referenced areas of application or under operating conditions other than described in the document and the technical data specified is defined as "inappropriate use".

Power supply units may not be used if

- they are subject to operating conditions that do not meet the above specified ambient conditions. This includes, for example, operation under water, in the case of extreme temperature fluctuations or extremely high maximum temperatures or if
- Rexroth Indramat has not specifically released them for that intended purpose. Please note the specifications outlined in the general safety instructions!

3 Safety Instructions

3.1 Introduction

Read these instructions before the equipment is used and eliminate the risk of personal injury or property damage. Follow these safety instructions at all times.

Do not attempt to install, use or service this equipment without first reading all documentation provided with the product. Read and understand these safety instructions and all user documentation of the equipment prior to working with the equipment at any time. If you do not have the user documentation for your equipment contact your local Rexroth Indramat representative to send this documentation immediately to the person or persons responsible for the safe operation of this equipment.

If the product is resold, rented or transferred or passed on to others, then these safety instructions must be delivered with the product.



WARNING

Inappropriate use of this equipment, failure to follow the safety instructions in this document or tampering with the product, including disabling of safety devices, may result in product damage, personal injury, severe electrical shock or death!

3.2 Explanations

The safety warnings in this documentation describe individual degrees of hazard seriousness in compliance with ANSI:



Warning symbol with signal word	Degree of hazard seriousness The degree of hazard seriousness describes the consequences resulting from non-compliance with the safety guidelines.
 DANGER	Bodily harm or product damage will occur.
 WARNING	Death or severe bodily harm may occur.
 CAUTION	Death or severe bodily harm may occur.

Fig. 3-1: Classes of danger with ANSI

3.3 Hazards by inappropriate use



DANGER

**High voltage and high discharge current!
Danger to life, risk of severe electrical shock
and risk of injury!**



DANGER

**Dangerous movements! Danger to life and risk
of injury or equipment damage by unintentional
motor movements!**



WARNING

**High electrical voltage due to wrong
connections! Danger to life, severe electrical
shock and severe bodily injury!**



WARNING

**Health hazard for persons with heart
pacemakers, metal implants and hearing aids in
proximity to electrical equipment!**



CAUTION

**Surface of machine housing could be extremely
hot! Danger of injury! Danger of burns!**



CAUTION

**Risk of injury due to inappropriate handling!
Bodily injury caused by crushing, shearing,
cutting and mechanical shock or improper
handling of pressurized systems!**



CAUTION

**Risk of injury due to inappropriate handling of
batteries!**

3.4 General Information

- Rexroth Indramat GmbH is not liable for damages resulting from failure to observe the warnings given in this documentation.
- Order operating, maintenance and safety instructions in your language before starting up the machine. If you find that due to a translation error you can not completely understand the documentation for your product, please ask your supplier to clarify.
- Proper and correct transport, storage, assembly and installation as well as care in operation and maintenance are prerequisites for optimal and safe operation of this equipment.
- Trained and qualified personnel in electrical equipment:
Only trained and qualified personnel may work on this equipment or within its proximity. Personnel are qualified if they have sufficient knowledge of the assembly, installation and operation of the product as well as an understanding of all warnings and precautionary measures noted in these instructions.
Furthermore, they should be trained, instructed and qualified to switch electrical circuits and equipment on and off, to ground them and to mark them according to the requirements of safe work practices and common sense. They must have adequate safety equipment and be trained in first aid.
- Only use spare parts and accessories approved by the manufacturer.
- Follow all safety regulations and requirements for the specific application as practiced in the country of use.
- The equipment is designed for installation on commercial machinery.
European countries: see directive 89/392/EEC (machine guideline).
- The ambient conditions given in the product documentation must be observed.
- Use only safety features that are clearly and explicitly approved in the Project Planning manual.
For example, the following areas of use are not allowed: Construction cranes, Elevators used for people or freight, Devices and vehicles to transport people, Medical applications, Refinery plants, the transport of hazardous goods, Radioactive or nuclear applications, Applications sensitive to high frequency, mining, food processing, Control of protection equipment (also in a machine).
- Start-up is only permitted once it is sure that the machine, in which the product is installed, complies with the requirements of national safety regulations and safety specifications of the application.
- Operation is only permitted if the national EMC regulations for the application are met.
The instructions for installation in accordance with EMC requirements can be found in the Rexroth Indramat document "EMC in Drive and Control Systems".
The machine builder is responsible for compliance with the limiting values as prescribed in the national regulations and specific EMC regulations for the application.
European countries: See Directive 89/336/EEC (EMC Guideline).
U.S.A.: See National Electrical Codes (NEC), National Electrical Manufacturers Association (NEMA), and local building codes. The user of this equipment must consult the above noted items at all times.
- Technical data, connections and operational conditions are specified in the product documentation and must be followed at all times.

3.5 Protection against contact with electrical parts

Note: This section refers to equipment with voltages above 50 Volts.

Making contact with parts conducting voltages above 50 Volts could be dangerous to personnel and cause an electrical shock. When operating electrical equipment, it is unavoidable that some parts of the unit conduct dangerous voltages.



DANGER

High electrical voltage! Danger to life, severe electrical shock and severe bodily injury!

- ⇒ Only those trained and qualified to work with or on electrical equipment are permitted to operate, maintain or repair this equipment.
- ⇒ Follow general construction and safety regulations when working on electrical installations.
- ⇒ Before switching on power the ground wire must be permanently connected to all electrical units according to the connection diagram.
- ⇒ Do not operate electrical equipment at any time if the ground wire is not permanently connected, even for brief measurements or tests.
- ⇒ Before working with electrical parts with voltage potentials higher than 50 V, the equipment must be disconnected from the mains voltage or power supply.
- ⇒ The following should be observed with electrical drives, power supplies, and filter components:
Wait five (5) minutes after switching off power to allow capacitors to discharge before beginning work. Measure the voltage on the capacitors before beginning work to make sure that the equipment is safe to touch.
- ⇒ Never touch the electrical connection points of a component while power is turned on.
- ⇒ Install the covers and guards provided with the equipment properly before switching the equipment on. Prevent contact with live parts at any time.
- ⇒ A residual-current-operated protective device (r.c.d.) must not be used on an electric drive! Indirect contact must be prevented by other means, for example, by an overcurrent protective device.
- ⇒ Equipment that is built into machines must be secured against direct contact. Use appropriate housings, for example a control cabinet.

European countries: according to EN 50178/1998, section 5.3.2.3.

U.S.A: See National Electrical Codes (NEC), National Electrical Manufacturers Association (NEMA) and local building codes. The user of this equipment must observe the above noted instructions at all times.

To be observed with electrical drives, power supplies, and filter components:



DANGER

**High electrical voltage! High leakage current!
Danger to life, danger of injury and bodily harm
from electrical shock!**

- ⇒ Before switching on power for electrical units, all housings and motors must be permanently grounded according to the connection diagram. This applies even for brief tests.
- ⇒ Leakage current exceeds 3.5 mA. Therefore the electrical equipment and units must always be firmly connected to the supply network.
- ⇒ Use a copper conductor with at least 10 mm² cross section over its entire course for this protective connection!
- ⇒ Prior to startups, even for brief tests, always connect the protective conductor or connect with ground wire. High voltage levels can occur on the housing that could lead to severe electrical shock and personal injury.

European countries: EN 50178/1998, section 5.3.2.1.

USA: See National Electrical Codes (NEC), National Electrical Manufacturers Association (NEMA), and local building codes. The user of this equipment must maintain the above noted instructions at all times.

3.6 Protection by protective low voltage (PELV) against electrical shock

All connections and terminals with voltages between 5 and 50 Volts on INDRAMAT products are protective low voltages designed in accordance with the following standards on contact safety:

- International: IEC 364-4-411.1.5
- EU countries: See EN 50178/1998, section 5.2.8.1.



WARNING

High electrical voltage due to wrong connections! Danger to life, severe electrical shock and severe bodily injury!

- ⇒ Only equipment, electrical components and cables of the protective low voltage type (PELV = Protective Extra Low Voltage) may be connected to all terminals and clamps with 0 to 50 Volts.
- ⇒ Only safely isolated voltages and electrical circuits may be connected. Safe isolation is achieved, for example, with an isolating transformer, an optoelectronic coupler or when battery-operated.

3.7 Protection against dangerous movements

Dangerous movements can be caused by faulty control or the connected motors. These causes are be various such as:

- unclean or wrong wiring of cable connections
- inappropriate or wrong operation of equipment
- malfunction of sensors, encoders and monitoring circuits
- defective components
- software errors

Dangerous movements can occur immediately after equipment is switched on or even after an unspecified time of trouble-free operation.

The monitors in the drive components make faulty operation almost impossible. Regarding personnel safety, especially the danger of bodily harm and property damage, this alone should not be relied upon to ensure complete safety. Until the built-in monitors become active and effective, it must be assumed in any case that some faulty drive movements will occur. The extent of these faulty drive movements depends upon the type of control and the state of operation.

**DANGER****Dangerous movements! Danger to life and risk of injury or equipment damage!**

⇒ Personnel protection must be secured for the above listed reason by means of superordinate monitors or measures.

These are instituted in accordance with the specific situation of the facility and a danger and fault analysis conducted by the manufacturer of the facility. All the safety regulations that apply to this facility are included therein. By switching off, circumventing or if safety devices have simply not been activated, then random machine movements or other types of faults can occur.

Avoiding accidents, injury or property damage:

⇒ Keep free and clear of the machine's range of motion and moving parts. Prevent people from accidentally entering the machine's range of movement:

- use protective fences
- use protective railings
- install protective coverings
- install light curtains or light barriers

⇒ Fences must be strong enough to withstand maximum possible momentum.

⇒ Mount the emergency stop switch (E-stop) in the immediate reach of the operator. Verify that the emergency stop works before startup. Don't operate the machine if the emergency stop is not working.

⇒ Isolate the drive power connection by means of an emergency stop circuit or use a start-inhibit system to prevent unintentional start-up.

⇒ Make sure that the drives are brought to standstill before accessing or entering the danger zone.

⇒ Secure vertical axes against falling or slipping after switching off the motor power by, for example:

- Mechanically securing the vertical axes
- Adding an external brake / clamping mechanism
- Balancing and thus compensating for the vertical axes mass and the gravitational force

The standard equipment motor brake or an external brake controlled directly by the servo drive are not sufficient to guarantee the safety of personnel!

- ⇒ Disconnect electrical power to the equipment using a master switch and secure the switch against reconnection for:
 - maintenance and repair work
 - cleaning of equipment
 - long periods of discontinued equipment use
 - ⇒ Avoid operating high-frequency, remote control and radio equipment near electronics circuits and supply leads. If use of such equipment cannot be avoided, verify the system and the plant for possible malfunctions at all possible positions of normal use before the first start-up. If necessary, perform a special electromagnetic compatibility (EMC) test on the plant.
-

3.8 Protection against magnetic and electromagnetic fields during operations and mounting

Magnetic and electromagnetic fields generated by current-carrying conductors and permanent magnets in motors represent a serious health hazard to persons with heart pacemakers, metal implants and hearing aids.



WARNING

Health hazard for persons with heart pacemakers, metal implants and hearing aids in proximity to electrical equipment!

- ⇒ Persons with pacemakers, metal implants and hearing aids are not permitted to enter following areas:
 - Areas in which electrical equipment and parts are mounted, being operated or started up.
 - Areas in which parts of motors with permanent magnets are being stored, operated, repaired or mounted.
 - ⇒ If it is necessary for a person with a pacemaker to enter such an area, then a physician must be consulted prior to doing so. Pacemakers, that are already implanted or will be implanted in the future, have a considerable deviation in their resistance to interference. Due to the unpredictable behavior there are no rules with general validity.
 - ⇒ Persons with hearing aids, metal implants or metal pieces must consult a doctor before they enter the areas described above. Otherwise health hazards will occur.
-

3.9 Protection against contact with hot parts



CAUTION

**Housing surfaces could be extremely hot!
Danger of injury! Danger of burns!**

- ⇒ Do not touch surfaces near the source of heat! Danger of burns!
- ⇒ Wait ten (10) minutes before you access any hot unit. Allow the unit to cool down.
- ⇒ Do not touch hot parts of the equipment, such as housings, heatsinks or resistors. Danger of burns!

3.10 Protection during handling and installation

Under certain conditions inappropriate handling and installation of parts and components may cause injuries.



CAUTION

**Risk of injury through incorrect handling!
Bodily harm caused by crushing, shearing,
cutting and mechanical shock!**

- ⇒ Observe general instructions and safety regulations during handling installation.
- ⇒ Use only appropriate lifting or moving equipment.
- ⇒ Take precautions to avoid pinching and crushing.
- ⇒ Use only appropriate tools. If specified by the product documentation, special tools must be used.
- ⇒ Use lifting devices and tools correctly and safely.
- ⇒ Wear appropriate protective clothing, e.g. safety glasses, safety shoes and safety gloves.
- ⇒ Never stay under suspended loads.
- ⇒ Clean up liquids from the floor immediately to prevent personnel from slipping.

3.11 Battery safety

Batteries contain reactive chemicals in a solid housing. Inappropriate handling may result in injuries or equipment damage.



CAUTION

Risk of injury through incorrect handling!

- ⇒ Do not attempt to reactivate discharged batteries by heating or other methods (danger of explosion and corrosion).
- ⇒ Never charge batteries (danger from leakage and explosion).
- ⇒ Never throw batteries into a fire.
- ⇒ Do not dismantle batteries.
- ⇒ Handle with care. Incorrect extraction or installation of a battery can damage equipment.

Note: Environmental protection and disposal! The batteries contained in the product should be considered as hazardous material for land, air and sea transport in the sense of the legal requirements (danger of explosion). Dispose batteries separately from other refuse. Observe the legal requirements given in the country of installation.

3.12 Protection against pressurized Systems

Certain Motors (ADS, ADM, 1MB etc.) and drives, corresponding to the information in the Project Planning manual, must be provided with and remain under a forced load such as compressed air, hydraulic oil, cooling fluid or coolant. In these cases, improper handling of the supply of the pressurized systems or connections of the fluid or air under pressure can lead to injuries or accidents.



CAUTION

Danger of injury when pressurized systems are handled by untrained personnel!

- ⇒ Do not attempt to disassemble, to open or to cut a pressurized system.
- ⇒ Observe the operation restrictions of the respective manufacturer.
- ⇒ Before the disassembly of pressurized systems, lower pressure and drain off the fluid or gas.
- ⇒ Use suitable protective clothing (for example protective eyewear, safety shoes and gloves).
- ⇒ Remove any fluid that has leaked out onto the floor immediately.

Note: Environmental protection and disposal! The fluids used in the operation of the pressurized system equipment is not environmentally compatible. Fluid that is damaging to the environment must be disposed of separate from normal waste. Observe the national specifications of the country of installation.

4 Technical data

4.1 Power supply units HVE

A bleeder resistor absorbs the energy regenerated by the HVE power supply units. Rexroth Indramat motors with a continuous mechanical power of 60 kW can be connected.

The HVE power supply units operate with unregulated DC bus voltage. The usable unit power depends on the power voltage. Therefore, power data for the connection to four mains nominal voltages are indicated:

- 3 x AC 380 V,
- 3 x AC 400 V,
- 3 x AC 440 V and
- 3 x AC 480 V.

The power supply units of the HVE type are available in three variations. They can, if necessary, be combined with the DC bus choke GLD. This makes an optimum adjusting to the power requirements of the application possible.

Note: For the technical data of the DC bus choke GLD see chapter 6-1.

P _{ZW} [kW]	P _{KB30} [kW]	P _{KB03} [kW]	P _{BD} [kW]	P _{BS} [kW]	W _{MAX} [kWs]	Mains supply components	
						Power supply unit	DC bus choke
HVE power data when connected to 3 x AC 380 V							
12	19	36	1	100	70	HVE02.2-W018N	-
18	29	54	1	100	70	HVE02.2-W018N	GLD13
18	36	54	1,5	100	100	HVE03.2-W030N	-
28	56	84	1,5	100	100	HVE03.2-W030N	GLD12
33	66	99	2,5	100	250	HVE04.2-W075N	-
70	140	210	2,5	100	250	HVE04.2-W075N	GLD20
HVE power data when connected to 3 x AC 400 V							
13	20	39	1	100	70	HVE02.2-W018N	-
19	30	57	1	100	70	HVE02.2-W018N	GLD13
19	38	57	1,5	100	100	HVE03.2-W030N	-
30	60	90	1,5	100	100	HVE03.2-W030N	GLD12
35	70	105	2,5	100	250	HVE04.2-W075N	-
75	150	225	2,5	100	250	HVE04.2-W075N	GLD20
HVE power data when connected to 3 x AC 440 V							
14	22	42	1	100	70	HVE02.2-W018N	-
21	33	63	1	100	70	HVE02.2-W018N	GLD13
21	42	63	1,5	100	100	HVE03.2-W030N	-
32	64	96	1,5	100	100	HVE03.2-W030N	GLD12
38	76	114	2,5	100	250	HVE04.2-W075N	-
82	164	246	2,5	100	250	HVE04.2-W075N	GLD20
HVE power data when connected to 3 x AC 480 V							
15	24	45	1	100	70	HVE02.2-W018N	-
23	36	69	1	100	70	HVE02.2-W018N	GLD13
23	46	69	1,5	100	100	HVE03.2-W030N	-
35	70	105	1,5	100	100	HVE03.2-W030N	GLD12
42	84	126	2,5	100	250	HVE04.2-W075N	-
90	180	270	2,5	100	250	HVE04.2-W075N	GLD20

P_{ZW}: continuous DC bus power
 P_{KB30}: short-term DC bus power (for 30 s)
 P_{KB03}: peak DC bus power (for 0,3 s)
 P_{BD}: continuous bleeder power
 P_{BS}: peak bleeder power
 W_{MAX}: maximum regenerated energy

Fig. 4-1: Power data of the HVE power supply units

To accelerate feed and spindle drives it is possible to apply the following short-term loads to the HVE as illustrated in the diagram below:



CAUTION

Damages due to an overloaded power supply unit!

⇒ Maximum short-term loads must be taken into consideration during the project planning phase and may not be exceeded.

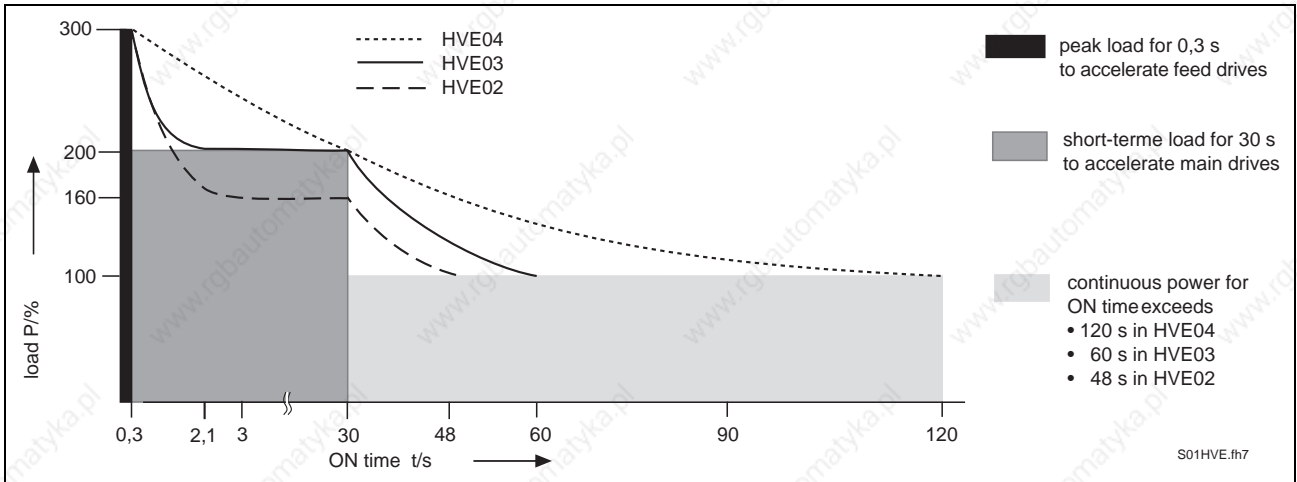

Fig. 4-2: Short-term output of the power supply units HVE02.2, HVE03.2 and HVE04.2

Designation	Symbol	Unit	Designation of the power supply unit		
			HVE02.2-W018N	HVE03.2-W030N	HVE04.2-W075N
Power supply					
Input voltage	U_{N1}	V	3 x 380 ... 480 ($\pm 10\%$)		
Frequency	f_{N1}	Hz	50 ... 60 (± 2 Hz)		
DC bus voltage	U_{ZW}	V	530 ... 670 ($\pm 10\%$)		
Output power					
DC bus continuous power	P_{ZW}	kW	see Fig. 4-1: Power data of the HVE power supply units		
Regenerated power (Bleeder power)					
Continuous bleeder power	P_{BD}	kW	1	1,5	2,5
Peak bleeder power	P_{BS}	kW	100	100	270
Maximum regenerated energy	W_{MAX}	kWs	70	100	250
Power loss					
Power loss at max. continuous output (without bleeder losses)	P_V	W	250	355	625
Basic losses	P_{VG}	W	125	175	175
Power losses per kW DC bus continuous power	$P_{V/kW}$	W/kW	7	6	6
Weight	m	kg	13	16	28
Control voltage supply					
Input voltage	U_{N2}	V	3 x 380 ... 480 ($\pm 10\%$)		
Frequency	f_{N2}	Hz	50 ... 60 (± 2 Hz)		
Power input with maximum load	S_{N2}	VA	500		
Control voltage output	P_{St}	W	300		
Conditions of use					
Permissible ambient temperature with rated data	T_{A1}	$^{\circ}\text{C}$	+5 ... +45		
Maximum permissible ambient temperature with derated data	T_{A2}	$^{\circ}\text{C}$	+55		
Storage and transport temperature	T_L	$^{\circ}\text{C}$	-30 ... +85		
Installation elevation without power reduction			1000 m above sea level		
Maximum permissible relative humidity			95 %		
Permissible absolute humidity			25 g water/ m ³ air		
Protection category			IP 10 per EN60529 / IEC529		
Degree of dirt contamination			no dirt contamination, no condensation		

Fig. 4-3: Data sheet HVE

4.2 Power supply unit HVR

HVR power supply units operate with regulated DC bus voltage. They can use mains voltages from 3 x AC 380 to 480 V ($\pm 10\%$). The usable unit power depends on the supply voltage.

P_{ZW} [kW]	P_{KB3} [kW]	P_{KB03} [kW]	P_{BD} [kW]	P_{BS} [kW]	P_{BS} [kW]	W_{MAX} [kWs]	Mains supply components	
							Power supply units	Auxiliary components
10	25	30	10	30	120	80	HVR02.2-W010N	KD30
25	60	75	25	75	120	80	HVR02.2-W025N	KD27
45	105	135	45	135	120	80	HVR03.2-W045N	KD28

P_{ZW} : continuous DC bus power

P_{KB3} : short-term DC bus power (for 3 s)

P_{KB03} : peak DC bus power (for 0,3 s)

P_{RD} : continuous regenerated power

P_{RS} : peak regenerated power

P_{BS} : peak bleeder power

W_{MAX} : maximum regenerated energy

Fig. 4-4: Power data of the HVR power supply units

To accelerate feed and main drives it is possible to apply the following short-term loads to the power supply units as illustrated in the diagram below.



CAUTION

Damages due to an overloaded power supply unit!

⇒ Maximum short-term loads must be taken into consideration during the project planning phase and may not be exceeded.

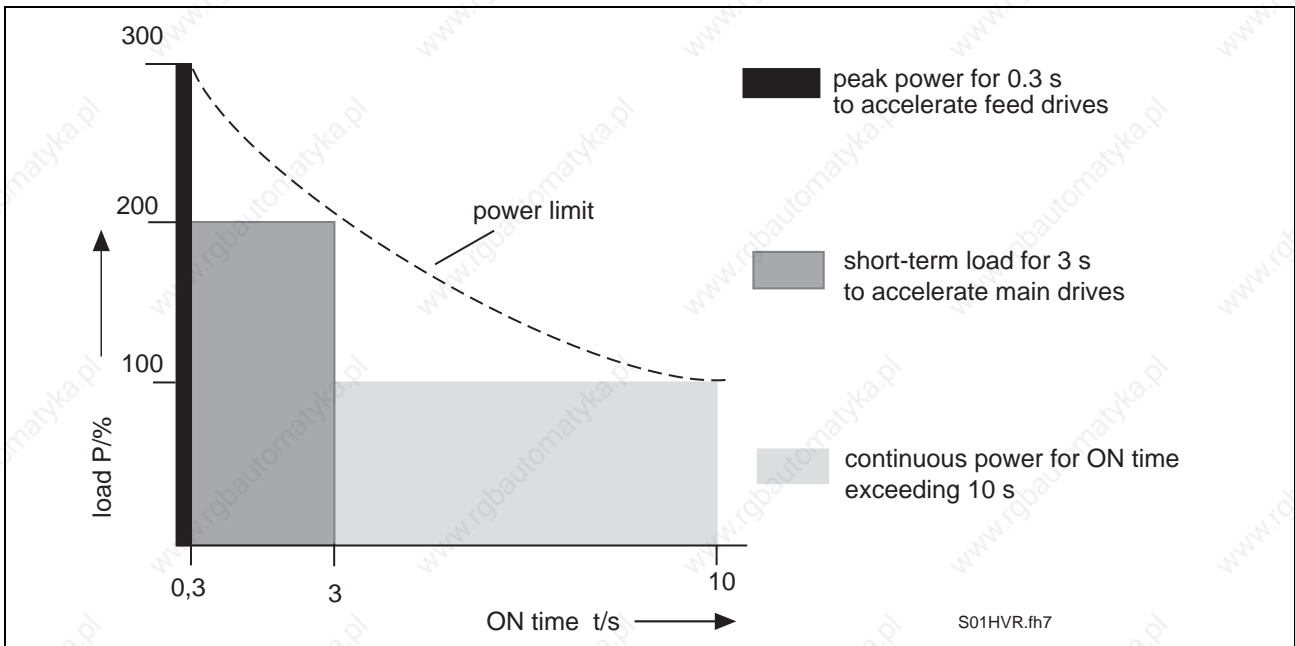

Fig. 4-5: Short-term output of the power supply unit HVR02.2 and HVR03.2

Designation	Symbol	Unit	Designation of the power supply unit		
			HVR02.2-W010N	HVR02.2-W025N	HVR03.2-W045N
Power supply					
Input voltage	U_{N1}	V	3 x 380 ... 480 ($\pm 10\%$)		
Frequency	f_{N1}	Hz	50 ... 60 (± 2 Hz)		
DC bus voltage	U_{ZW}	V	750		
Output power ^(*1)					
DC bus continuous power (for $U_{N1}=400$ V) ^(*2)	P_{ZW}	kW	10	25	45
DC bus peak output (for 0,3 s)	P_{ZWS03}	kW	30	75	135
Regenerated power (Bleeder power)					
Continuous bleeder power	P_{BD}	kW	0 (Bleeder has not been designed for Emergency Stop)		
Peak bleeder power	P_{BS}	kW	120		
Maximum regenerated energy	W_{MAX}	kWs	80		
Power loss					
Power loss at max. continuous output (without bleeder losses)	P_V	W	300	750	1350
Basic losses	P_{VG}	W	150		
Power losses per kW DC bus continuous power	$P_{V/kW}$	W/kW	15	24	27
Weight	m	kg	21	21	31
Control voltage supply					
Input voltage	U_{N2}	V	3 x 380 ... 480 ($\pm 10\%$)		
Frequency	f_{N2}	Hz	50 ... 60 (± 2 Hz)		
Power input with maximum load	S_{N2}	VA	500		
Control voltage output	P_{St}	W	300		
Conditions of use					
Permissible ambient temperature with rated data	T_{A1}	$^{\circ}C$	+5 ... +45		
Maximum permissible ambient temperature with derated data	T_{A2}	$^{\circ}C$	+55		
Storage and transport temperature	T_L	$^{\circ}C$	-30 ... +85		
Installation elevation without power reduction			1000 m above sea level		
Maximum permissible relative humidity			95 %		
Permissible absolute humidity			25 g water/ m ³ air		
Protection category			IP 10 per EN60529 / IEC529		
Degree of dirt contamination			no dirt contamination, no condensation		

(*1): The same values apply to feeding and regeneration

(*2): In case of mains voltages under 400 V, the DC bus continuous power

is reduced in the ratio: $P_{ZW} * \frac{U_{N1}}{400 V}$

Fig. 4-6: Data sheet HVR

4.3 Commutation choke KD

Type	Inductance [mH]	Current [A]	Basic losses [W]	Load dependent losses [W/kW]	Power loss [W]
KD 27	0,7	45	250	10	500
KD 28	0,5	80	300	7	600
KD 30	1,0	18	150	15	300

Basic losses: arise with existing DC bus voltage; drives in "AF"; drive is shut down

Load dependent losses: arise per kW DC bus power

Power loss: (total losses) the same values apply to feeding and regeneration

Fig. 4-7: Data sheet commutation choke KD xx

4.4 Combining filter HZF

Type	Nominal current [A]	Basic losses [W]	Load dependent losses [W/kW]	Power loss [W]
HZF01.1-W010N	18	100	10	200
HZF01.1-W025N	45	150	6,0	300
HZF01.1-W045N	80	200	4,5	400

Basic losses: arise with existing DC bus voltage; drives in "AF"; drive is shut down

Load dependent losses: arise per kW DC bus power

Power loss: (total losses) the same values apply to feeding and regeneration

Fig. 4-8: Data sheet combining filter HZF

5 Determination of appropriate power supply units

5.1 Introduction

The mains supply for an AC drive system of the DIAX04 product family mainly consists of the power supply unit. Depending on the tasks and design of the supply unit and the conditions of its use, it may be necessary to add link reactors, auxiliary capacitors, bleeder modules and transformers as needed.

The mains supply must make available to the drives the DC bus continuous power and the DC bus peak power for acceleration. During regenerative operation it must be able to store continuous and peak regenerated power. The supply unit also makes the control voltage for the drive controllers available.

Prior to selecting supply unit and auxiliary components it is necessary to determine the motors and drive controllers which will be used.

It is advisable to carry out calculations in accordance with the following chapters in order to make sure that the layout of the mains supply is correct.

5.2 DC bus continuous power

Note: It is possible to connect DC bus chokes of the GLD type to HVE supply modules so that the usable DC bus continuous power is increased (see Fig. 4-1: Power data of the HVE power supply units).

The DC bus continuous power is calculated from the mechanical power and based on the efficiency of motor and controller as well as coincidence factors.

Mechanical power

$$P_m [W] = M * \omega = \frac{M * 2\pi n}{60} \quad \text{or}$$

$$P_m [kW] = \frac{M * n}{9550}$$

P_m : mechanical power
 M : torque [Nm]
 ω : angular speed [min^{-1}]
 n : motor speed [min^{-1}]

Fig. 5-1: Mechanical power

Continuous mechanical power for servo drives

The effective motor torque and average motor speed are needed to calculate the mechanical continuous power of a servo drive.

The effective motor torque of the servo drive calculations can be assumed. The average motor speed is determined as follows:

Average motor speed

The average motor speed equals approximately 25% of the rapid motion speed - in the case of servo drive tasks in conventional NC machine tools. In some cases, however, this approximate estimation is not sufficient. A precise calculation of the average motor speed is necessary.

If the duration over which the drive is operated at constant speed is considerably greater than the accel and decel time, then it applies:

Average speed without accel and decel time

$$n_{av} = \frac{n_1 * t_1 + n_2 * t_2 + \dots + n_n * t_n}{t_1 + t_2 \dots + t_n}$$

- n_{av}: average motor speed [min⁻¹]
- n₁ ... n_n: motor speed [min⁻¹]
- t₁ ... t_n: ON time [s]

Fig. 5-2: Average speed; influence of accel and decel time is not taken into consideration

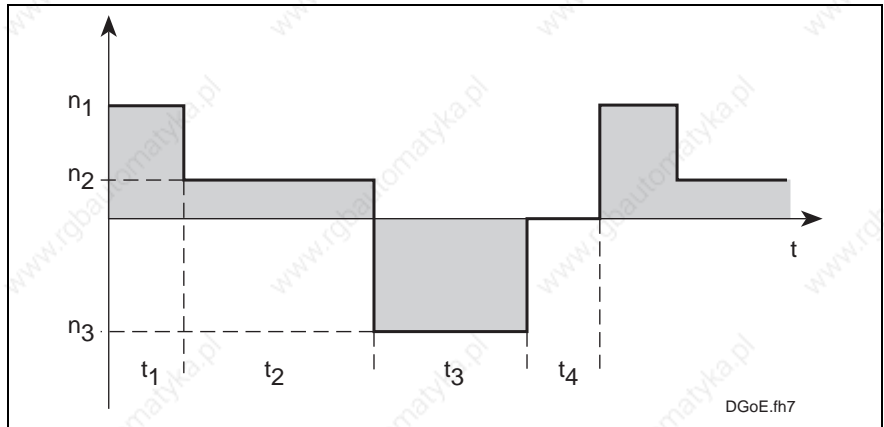

Fig. 5-3: Speed cycle; influence of accel and decel time is not taken into consideration

Accel and decel times with short cycle times must be taken into consideration in such dynamic applications as is the case with rollers and nibbel machines.:

Average speed with accel and decel times

$$n_{av} = \frac{\frac{n}{2} * t_H + n * t_1 + \frac{n}{2} * t_B}{t_H + t_1 + t_B + t_2}$$

- n_{av}: average motor speed [min⁻¹]
- n: motor speed [min⁻¹]
- t: time [s]
- t_H: accel time [s]
- t_B: decel time [s]

Fig. 5-4: Average speed; influence of accel and decel time is taken into consideration

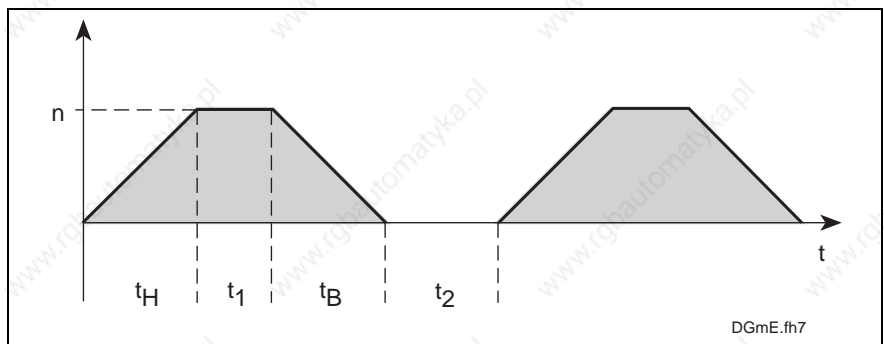

Fig. 5-5: Average speed; influence of accel and decel time is taken into consideration

Mechanical power for servo drives

$$P_{mSe} = \frac{M_{eff} * n_{av}}{9550}$$

P_{mSe} : continuous mech. power for servo drives [kW]
 M_{eff} : effective motor torque [Nm]
 n_{av} : average motor speed [min^{-1}]

Fig. 5-6: Mechanical power for servo drives

Mechanical power for main drives

Main drives are primarily used with constant power over a specific speed range. This means that when planning power supply, nominal power is important. The mechanical nominal power of the main drives is illustrated in the operating characteristics or it can be calculated using nominal speed and torque.

$$P_{mHa} = \frac{M_n * n_n}{9550}$$

P_{mHa} : mechanical nominal power for main drives (shaft output) [kW]
 M_n : motor nominal torque [Nm]
 n_n : motor nominal speed [min^{-1}]

Fig. 5-7: Mechanical power for main drives

DC bus continuous power for servo drives

The power supply unit must make the DC bus continuous power available to all servo drives. All drives are operated simultaneously in only a few applications which means that only the simultaneously occurring output needs to be considered. For the calculation of the required DC bus continuous power for typical NC feed axes on tool machines, it has proven in practice that a so-called coincidence factor is included:

Number of Axes	1	2	3	4	5	6
Coincidence factor (F_G)	1	1,15	1,32	1,75	2,0	2,25

Fig. 5-8: Coincidence factors

$$P = \frac{(P_{mSe1} + P_{mSe2} + \dots + P_{mSen}) * 1,25}{F_G}$$

P_{ZWSe} : DC bus continuous power for servo drives [kW]
 $P_{mSe1} \dots P_{mSen}$: cont. mech. power for servo drives [kW]
 F_G : coincidence factor
 1,25: constant for motor and controller efficiency

Fig. 5-9: DC bus continuous power for servo drives

DC bus continuous power for main drives

If several main drives are operated on one DC bus, then add the simultaneously required power:

$$P_{ZWHa} = (P_{mHa1} + P_{mHa2} + \dots + P_{mHan}) * 1,25$$

P_{ZWHa} : DC bus continuous power for main drives [kW]
 $P_{mHa1} \dots P_{mHan}$: mech. cont. power for main drives [kW]
 1,25: constant for motor and controller efficiency

Fig. 5-10: DC bus continuous power for main drives

Chokes and auxiliary capacitors are selected in terms of the actually required DC bus continuous power. It is fixed by the nominal power of the spindle drives.

Note: When selecting the power supply unit make sure that the DC bus continuous power does not limit the short-term power of the main drives.

DC bus continuous power for main and servo drives

If main and servo drives are operated on a power supply unit, the required DC bus continuous power needs to be added.

It is the spindle drive in a NC machine tool that primarily determines the DC bus power needed. Therefore, the following equation should be applied in such applications:

$$P_{ZW} = [P_{mHa} + 0,3 * (P_{mSe1} + P_{mSe2} + \dots P_{mSen})] * 1,25$$

- 0,3: experimental value for standard machine tools
 1,25: constant for motor and controller efficiency
 P_{ZW} : DC bus continuous power [kW]
 $P_{mSe1} \dots P_{mSen}$: continuous mech. servo drive output [kW]
 P_{ZWHa} : nominal power for spindle drives (shaft output) [kW]

Fig. 5-11: DC bus continuous power for spindle and servo drives in machine tools

5.3 DC bus peak power

The DC bus peak power is demanded of the power supply unit when, e.g., several axes of a machine tool simultaneously accelerate to rapid traverse and then go to a workpiece after a tool change.



CAUTION

Damages due to overloaded power supply unit!

⇒ Damages to the power supply unit can be avoided, if the sum of the peak power of all drives does not exceed the DC bus peak power of the power supply unit.

$$P_{ZWS} = \frac{(M_{NC} \pm M_G) * n_{eil} * 1,25}{9550}$$

- 1,25: constant for motor and controller efficiency
 M_{NC} : acceleration torque in NC mode [Nm]
 M_G : weight torque in vertical axes [Nm]
 n_{eil} : speed in rapid traverse [min^{-1}]
 P_{ZWS} : DC bus peak power [kW]

Fig. 5-12: DC bus peak power per drive

$$\sum P_{ZWS} \leq P_{ZWS03}$$

- P_{ZWS} : DC bus peak power [kW]
 P_{ZWS03} : DC bus peak power of the power supply unit [kW]

Fig. 5-13: Sum of DC bus peak powers

5.4 Regenerated energy

The energy content of all main and servo drives that brake simultaneously under unfavorable conditions may not be greater than the maximum regenerated energy of the power supply unit as specified in the data sheet. If this is not taken into consideration during the layout stage, then there could be thermal damage to the bleeder resistor in the power supply unit!



CAUTION

Property damages due to overloaded bleeder resistor!

⇒ Use a power supply unit that is appropriate for the consumption of the regenerated power which arises when all the main and servo drives connected to the power supply unit brake simultaneously.

$$W_{rot} = \frac{J_G}{2} * \left(n_{eil} * \frac{2\pi}{60} \right)^2$$

W_{rot} : rotary energy [Ws]

n_{eil} : rapid traverse speed [min^{-1}]

J_G : inertia of motor and load inertia reduced to shaft [kgm^2]

Fig. 5-14: Regenerated energy per drive

$$\sum W_{rot} \leq W_{MAX}$$

W_{rot} : rotary energy [Ws]

W_{MAX} : max. permissible regenerated energy of the power supply module [kWs]

Fig. 5-15: Sum of regenerated energies

Auxiliary capacitance as energy storage in the HVE

In servo drive applications with numerous accel and decel procedures, as is the case, for example, with nibble machines and rollers, it is advisable to connect additional capacitors to the DC bus. The following advantages result from this:

- This prevents the bleeder resistor in the HVE power supply unit from being actuated while braking: The heat dissipated within the control cabinet is considerably reduced.
- The stored energy can be used to accelerate thus reducing energy requirements of the installation.

$$W_{ZW} = \frac{C_{ZW}}{2} * (U_B^2 - U_{ZW}^2)$$

W_{ZW} : energy stored in the DC bus

C_{ZW} : DC bus capacitor [F]

U_B : bleeder actuation threshold (approx. 820 V)

U_{ZW} : DC bus nominal voltage [in the HVR: $U_{DC}=750$ V; in the HVE: $U_{DC}=1,41*U_{N1}+10\%$ (overvoltage), (U_{N1} =nominal mains voltage (380 ... 480 V)]

Fig. 5-16: Energy that can be stored in the DC bus

The auxiliary capacitor must be designed so that it is capable of storing rotary drive energy:

$$C_{Zu} \geq \frac{2W_{rot}}{(U_B^2 - U_{ZW}^2)} * 1000 - 1mF$$

U_B : bleeder actuation threshold (approx. 820 V)

U_{ZW} : DC bus nominal voltage [in the HVR: $U_{DC}=750$ V; in the HVE: $U_{DC}=1,41*U_{N1}+10\%$ (overvoltage), (U_{N1} =nominal mains voltage (380 ... 480 V)]

W_{rot} : rotatory energy [Ws]

C_{Zu} : auxiliary capacitor [mF]

Fig. 5-17: Required auxiliary capacitance

In power supply units with regulated DC bus voltage, e.g., HVR, approximately 75 Ws per mF auxiliary capacitance can be stored.

In power supply units with unregulated DC bus voltage, e.g., HVE, the auxiliary capacitance should be designed for 10% overvoltage. The storable energy per mF auxiliary capacitance is listed in the table below.

Mains voltage	3 x AC 380 V	3 x AC 400 V	3 x AC 440 V	3 x AC 480 V
storable energy per mF auxiliary capacitance	163 Ws	144 Ws	103 Ws	89 Ws

Fig. 5-18: Storable energy with auxiliary capacitance on an HVE

5.5 Continuous regenerated power

The average sum of the continuous regenerated power of all drives may not exceed the continuous regenerated power in the HVR or the continuous bleeder power in the HVE.

The processing time in servo drive applications given a typical NC machine tool, is relatively long in terms of the entire cycle time. There is little regenerated continuous power. An exact calculation is generally not required. It suffices if the peak regenerated power is not exceeded.

An exact calculation is needed in specific cases such as, for example:

- servo drive applications with numerous accel / decel procedures such as is the case in nibble machines and rollers
- machine tools with modular main drives
- applications in which excessive masses must be lowered as is the case with those overhead gantries used with storage and transport technologies

To calculate continuous regenerated power, the rotary energy of the drives and the potential energy of non-compensated masses must be known.

$$W_{rot} = \frac{J_g}{2} * \left(n_{eil} * \frac{2\pi}{60} \right)^2 * z$$

W_{rot} : rotary energy [Ws]

n_{eil} : speed in rapid traverse [min^{-1}]

J_g : moment of inertia (motor + load) [kgm^2]

z : number of decels per cycle

Fig. 5-19: Rotary energy

$$W_{pot} = m * g * h * z$$

W_{pot} : potential energy [Ws]
 m : load mass [kg]
 g : gravity constant = 9,81 m/s²
 h : drop height [m]
 z : number of drops per cycle

Fig. 5-20: Potential energy of non-compensated masses

$$P_{RD} = \frac{W_{potg} + W_{rotg}}{t_z} \quad P_{RD} \leq P_{BD}$$

P_{RD} : continuous regenerated power [kW]
 P_{BD} : continuous bleeder power [kW]
 t_z : cycle time [s]
 W_{potg} : sum of potential energy [kWs]
 W_{rotg} : sum of rotary energies [kWs]

Fig. 5-21: Continuous regenerated energy

5.6 Peak regenerated power

The peak regenerated power usually arises, when an Emergency Stop signal has been released and all the axes brake simultaneously.



CAUTION

Property damages due to longer braking periods/paths!

⇒ Choose the power supply unit such that the sum of the peak regenerated power of the all drives does not exceed the bleeder peak power of the power supply unit.

The peak regenerated power of the servo drives is listed in the motor selection documentation.

Roughly estimated, the peak regenerated power can be calculated as follows:

$$P_{RS} = \frac{M_{max} * n_{max}}{9550 * 1,25} \quad \sum P_{RS} \leq P_{BS}$$

P_{RS} : peak regenerated power [kW]
 P_{BS} : peak bleeder power [kW]
 M_{max} : max. drive torque [Nm]
 n_{max} : max. NC usable speed [min⁻¹]
 1,25: constant for motor and controller efficiency

Fig. 5-22: Peak regenerated power

5.7 Connected load of the power supply unit

The connected load is calculated to be able to determine mains fuses, line cross sections and, if needed, commutation chokes and transformers.

The connected load is dependent on the continuous power of the drives and the functional principle of the power supply unit.

$$\text{without DC choke (GLD): } S_{N1} = P_{ZW} * 1,6$$

$$\text{with DC choke (GLD): } S_{N1} = P_{ZW} * 1,07$$

S_{N1} : connected load [kVA]

P_{ZW} : DC bus continuous power [kW]

Fig. 5-23: Connected load for power supply units of the HVE line

$$S_{N1} = P_{ZW} * 1,05$$

S_{N1} : connected load [kVA]

P_{ZW} : DC bus continuous power [kW]

Fig. 5-24: Connected load for power supply units of the HVR line

$$I_{N1} = \frac{S_{N1} * 1000}{\sqrt{3} * U_{N1}}$$

I_{N1} : mains current [I]

S_{N1} : connected load [kVA]

U_{N1} : mains voltage [U]

Fig. 5-25: Mains current

5.8 Using the control voltage



CAUTION

Property damage due to overloaded control voltage outlet!

⇒ The control voltage power of the power supply unit may not be overloaded when the drive controller processes signals. If the control voltages are used outside of the drive system, e. g., to supply auxiliary relays, then this must be taken into account (see data in Fig. 4-3 and Fig. 4-6).

6 Auxiliary components

6.1 DC bus choke GLD

DC bus chokes GLD may be connected to HVE supply modules so that the usable DC bus power is increased.

The following figures show the unit dimensions and the technical data of the DC bus chokes. For the DC bus power with or without chokes on the corresponding supply module types please see figure Fig. 4-1.

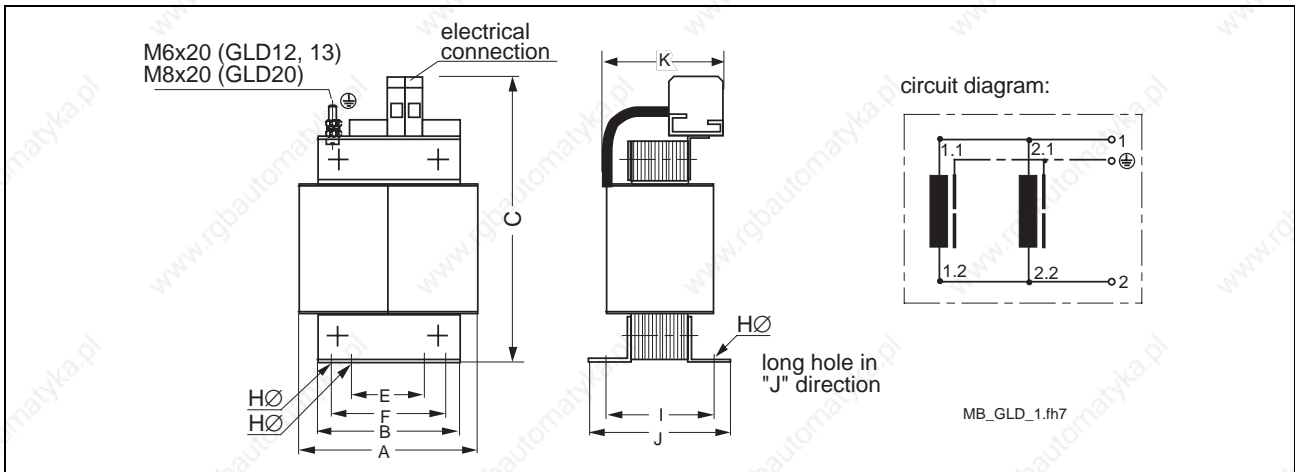

Type	Dimensions [mm]									Maximum wire range [mm²]	Weight [kg]
	A	B	C	E	F	HØ	I	J	K		
GLD12	160	121	285	60	100	7x14	97	121	-	35	13,5
GLD13	122	90	225	-	60	6x10	66	82	-	16	4,8
GLD20	225	170	380	-	135	10x18	145	175	190	50	35,0

Fig. 6-1: Dimension drawing of the DC bus chokes GLD

Type	Inductance [mH/A]	Basic losses [W]	Load dependent losses [W/kW]	Power loss [W]
GLD12	1,0/100	50	1,7	100
GLD13	1,0/50	25	1,4	50
GLD20	1,0/140	100	1,3	200

Basic losses: arise with existing bus voltage; drive in "AF"; drive in shut down
 Load dependent losses: arise per kW DC bus power
 Power loss: consists of the basic losses and the load dependent losses

Fig. 6-2: Technical data of the DC bus chokes GLD

6.2 Additional capacitance module HZK

The additional capacitance modules HZK fulfill the following characteristics:

Reduce loss of heat	High losses of heat arise on systems whose feed axes need to accelerate constantly and brake in short intervals (e.g. nibble machines, surface grinding machines, roll feeds, etc.). With additional capacitance on the DC bus, the bleeder continuous power and thus the loss of heat can be reduced.
To increase the power in case of a power failure	The possibility to move on a certain traverse path (e.g. for a reverse motion), even when a power failure occurs, requires the storage of energy in the DC bus. The storable energy can be increased through additional capacitance on the DC bus.

Dimensioning and unit arrangement

Maximum possible additional capacitance	It is possible to connect 10 mF of additional capacitance to the DC bus of the HVE supply module and 20 mF of additional capacitance to the DC bus of the HVR supply module without additional charging set. It is necessary to combine several additional capacitance modules of the type HZK02.1-W003N so that the above-mentioned additional capacitance can be realized. Every additional capacitance module of this type has a nominal capacity of 3 mF. As a result, a maximum of three HZK modules can be connected to the DC bus of HVE units and a maximum of six HZK modules can be connected to the DC bus of HVR units.
Arrangement	The HZK modules must be located next to the drives of greatest performance in the DIAX04 package.
Connection, monitoring and diagnostics	There is no monitoring or diagnosis logic in the HZK available. Therefore, the connection of the X1-bus is only necessary, if other units are mounted on both sides of the HZK. It is necessary to connect the DC bus and the operating ground so that a proper and safe operation can be ensured.

Front view

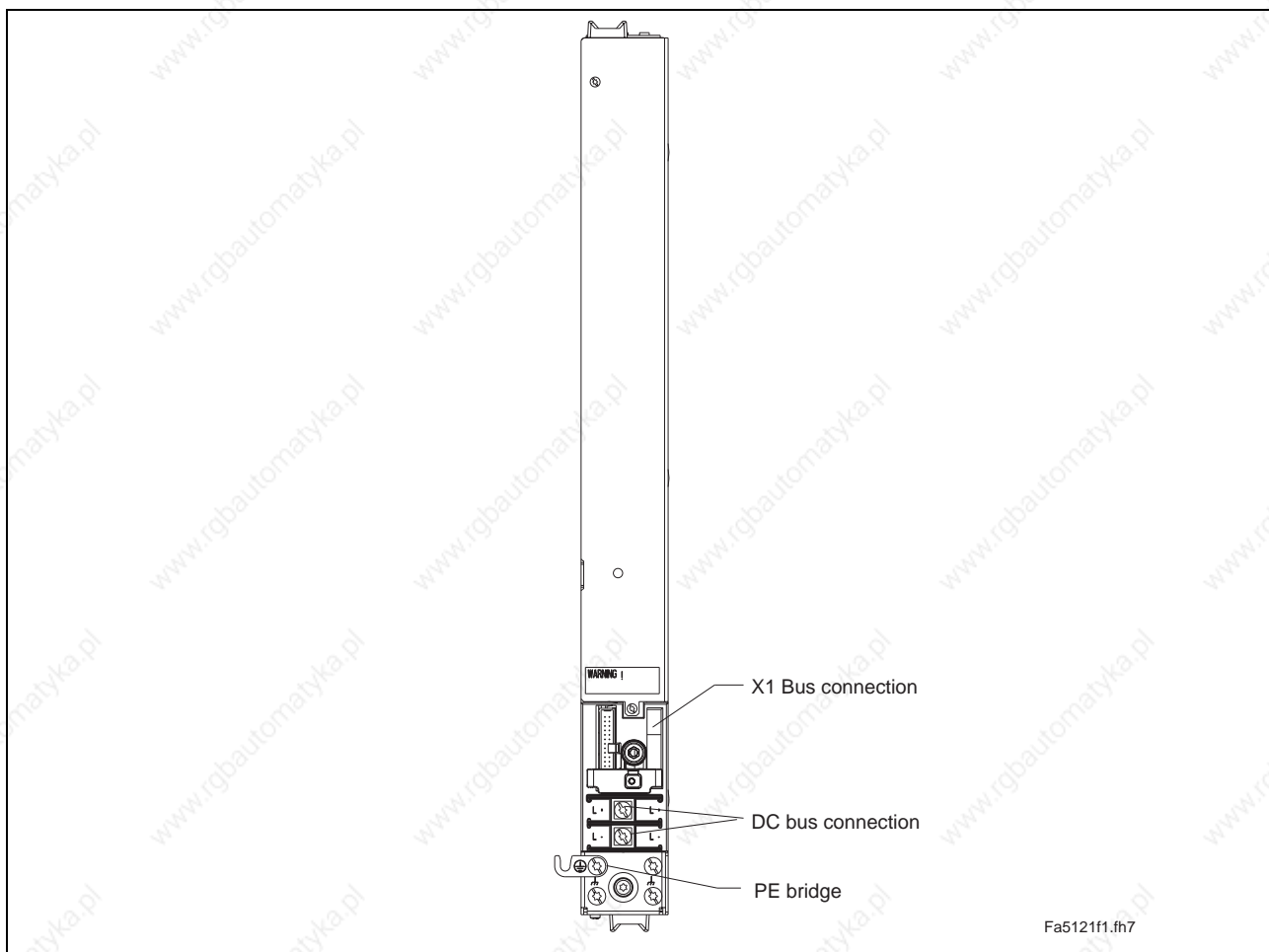

Fig. 6-3: Front view HZK02.1-W003N

Note: The scope of delivery includes the copper strand for the DC bus connection as well as the PE bridge.

The flat cable on the X1 terminal is firmly connected to the unit (X1 is also the designation of the free multiple contact strip for looping through the X1 connections).

Unit dimensions

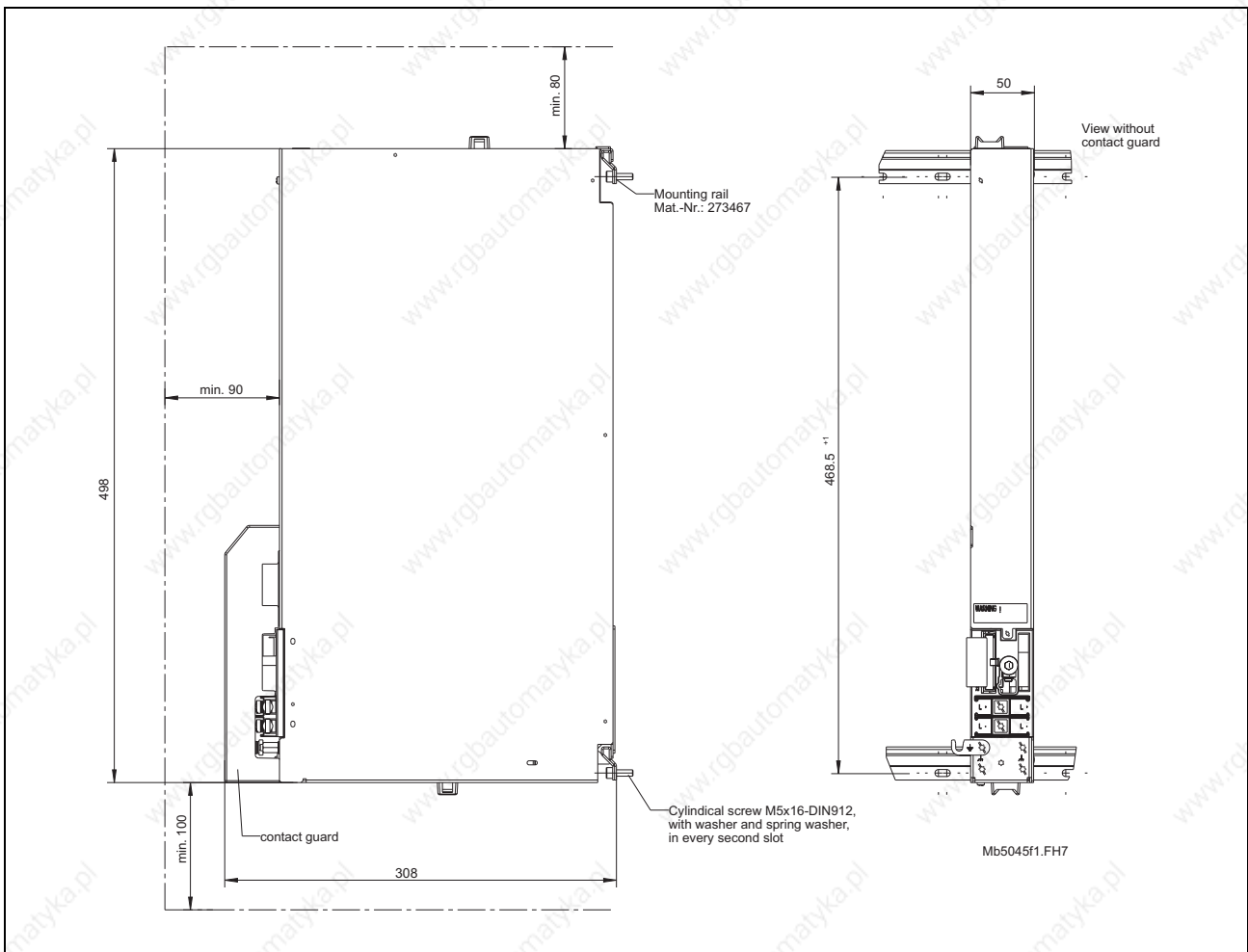

Fig. 6-4: Dimension drawing HZK02.1-W003N

6.3 Additional bleeder module HZB

The additional bleeder module is required, if the bleeder power of the applied HVE supply module is not sufficient for the braking energy arising in the application.

It can also be applied together with a regenerative HVR supply unit in order to manage great braking energies in case of power failures.

Unit arrangement

The additional bleeder module must always be located next to the supply unit in the drive package.

Technical data

P_{DB} [kW]	W_{Max} [kW]	U_{N1} [V]
2	250	0 ... 900

P_{DB} : Bleeder continuous power

W_{Max} : maximum regenerated power

U_{N1} : Connection voltage

Fig. 6-5: Technical data HZB02.2-W002N

Connection, monitoring and diagnostics

The additional bleeder module HZB monitors

- the full load of the bleeder resistor,
- the temperature of the bleeder resistor and
- the temperature of the power electronics.

The communication between supply and additional bleeder module requires the following connections:

- X0-Bus, supply module ↔ X0-Bus, additional bleeder module [non-connected X0-plugs must be bridged (X0, Pin1 with Pin5 and X0, Pin6 with Pin10 respectively X0, Pin11 with Pin15 and X0, Pin16 with Pin20)]
- X1-Bus, supply module ↔ X1-Bus, additional bleeder module

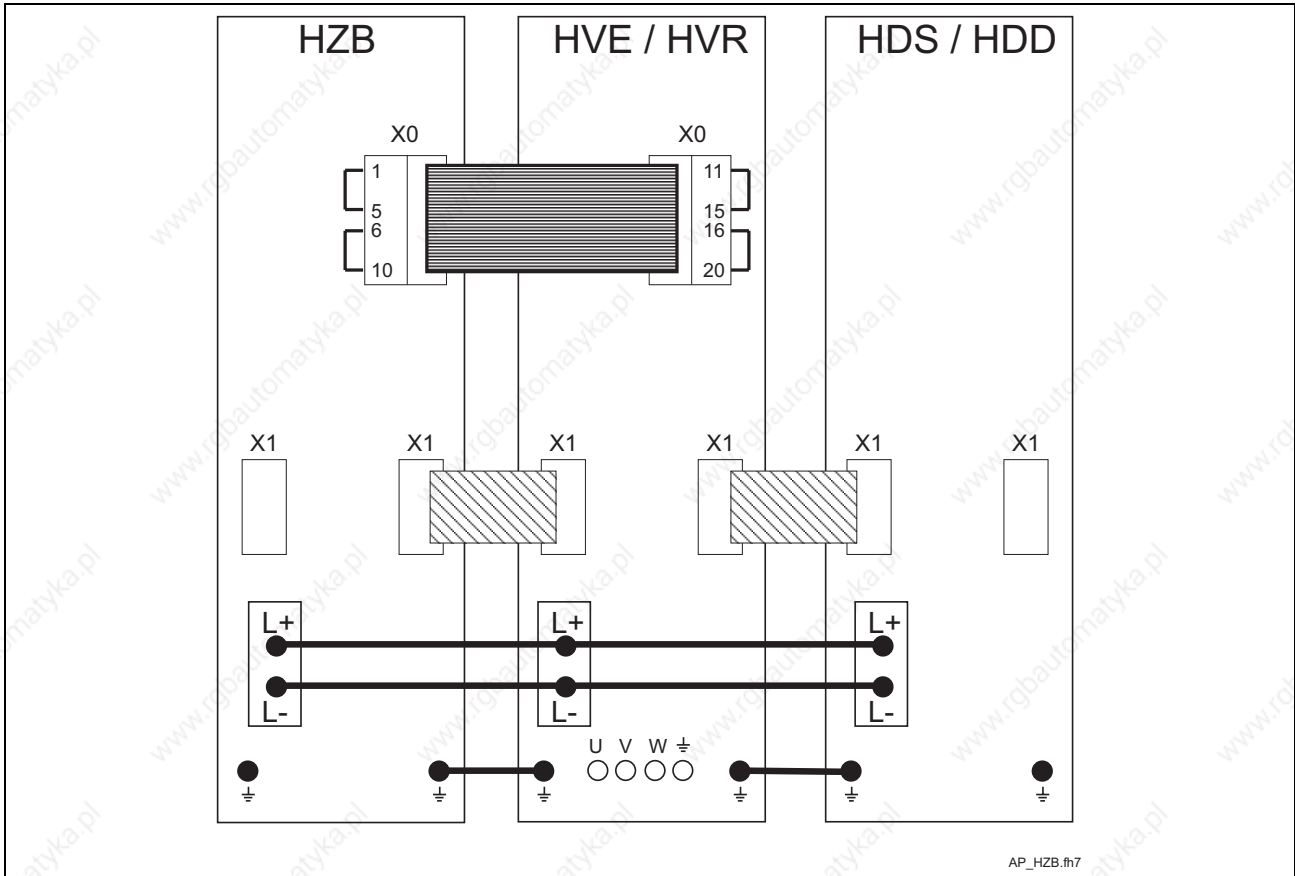

Fig. 6-6: Unit wiring when an HZB unit is used

Note: The following description of the unit monitoring is visualized in the next figure (Fig. 6-7).

If one of the three monitored values achieves 90 % of the permissible maximum value, a warning will be displayed on the supply module (additional capacitance warning) as well as on the HZB display.

The warning opens simultaneously the pre-warning contact (terminal X7, pin 5 and 6) in the supply module (HVR and HVE).

The pre-warning contact (terminal X7, pin 5 and 6) as well as the bleeder warning contact (terminal X7, pin 7 and 8) open in the HVE.

From the time when the warning occurs, the user has 30 seconds to prepare countermeasures. If the value does not remain under 90% during this time, the additional bleeder module announces "additional component

error" and the main contactor K1 is deactivated. The error message is stored in the HZB as long as it is reset manually by the reset button S1.

If one of the maximum values is reached, the message "additional component error" will appear immediately. In this case the main contactor K1 is deactivated as well.

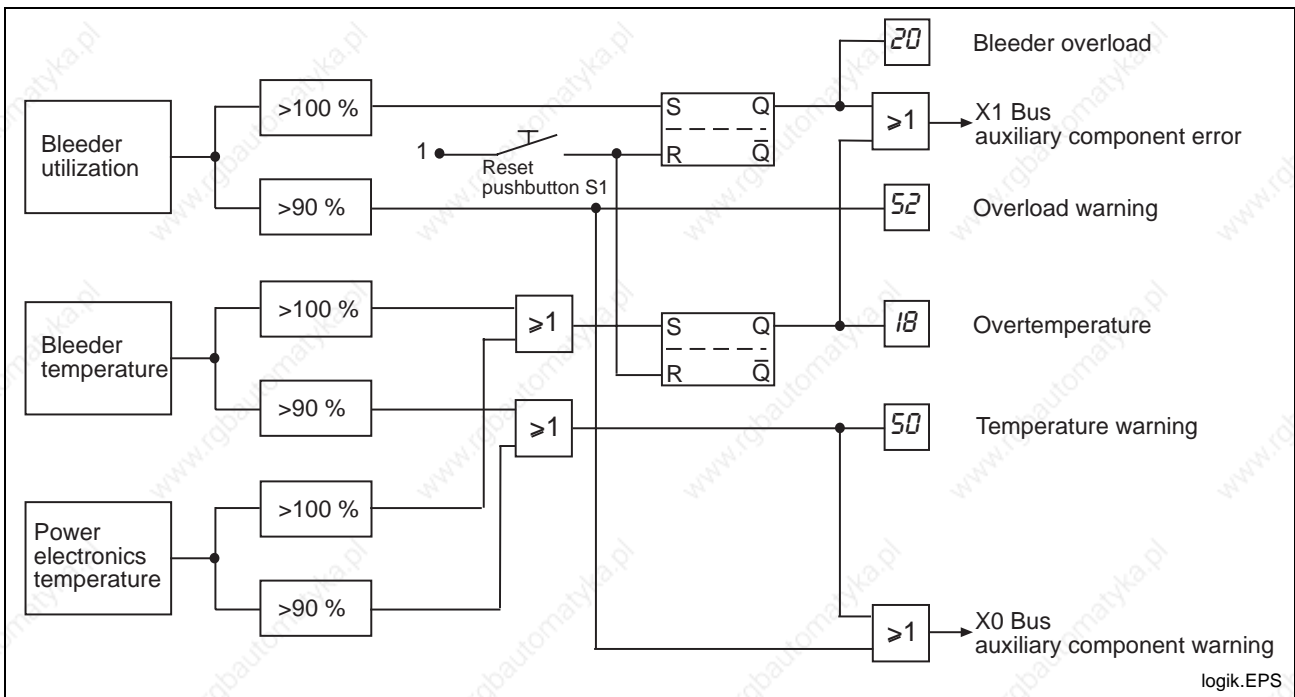

Fig. 6-7: Monitoring and diagnostic logic HZB02.2-W002N

Front view

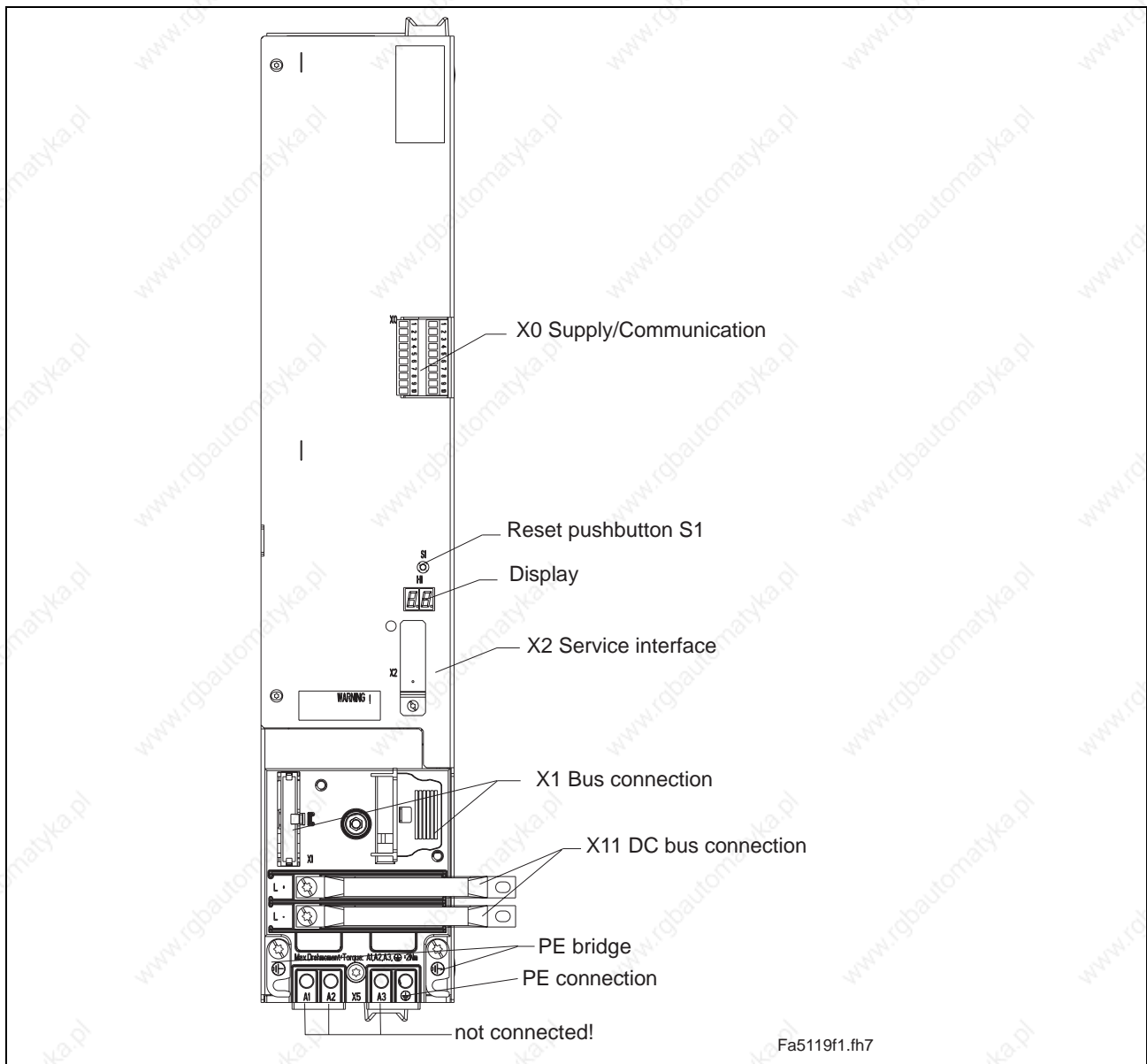

Fig. 6-8: Front view HZB02.2-W002N

Note: The scope of delivery includes the copper strand for the DC bus connection as well as the PE bridge.

The flat cable on terminal X1 is firmly connected to the unit (X1 is also the designation of the free multiple contact strip for looping through the X1-connections).

Unit dimensions

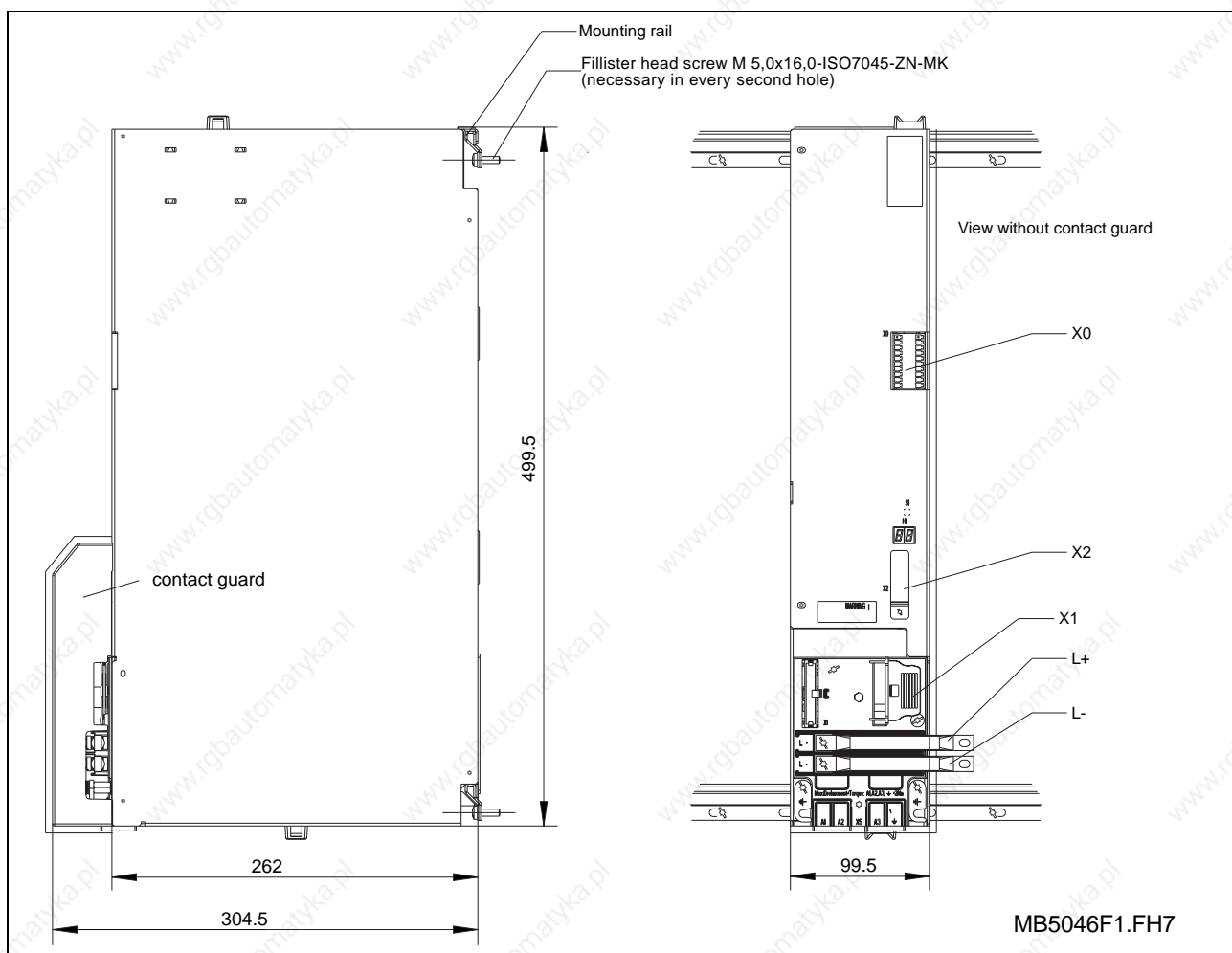

Fig. 6-9: Dimension drawing HVB02.2-W002N

7 Mounting

7.1 Control cabinet planning

Conditions of use

Ambient temperature and installation elevation

The nominal data for the power supply units (see chapter 4 "Technical data") apply to

- Ambient temperature range of +5° to +45° C and
- installation elevation of 0 to 1000 m above sea level.

Note: If the power supply unit is used in situations that exceed this range, then the "load factors" must be taken into account. This derates the power data.



Damage to the units due to operation outside of the specified conditions of use!

⇒ Those power supply units operated outside of the specified conditions of use can be damaged. Doing so also means that the guarantee will be forfeited!



Damage to the units due to overloaded power supply unit!

⇒ If you want to use power supply units outside of the specified conditions of use, please check first, whether the performance data are sufficient. Please check by reading the load factor(s) from the diagrams in Fig. 7-1 and follow the instructions below!

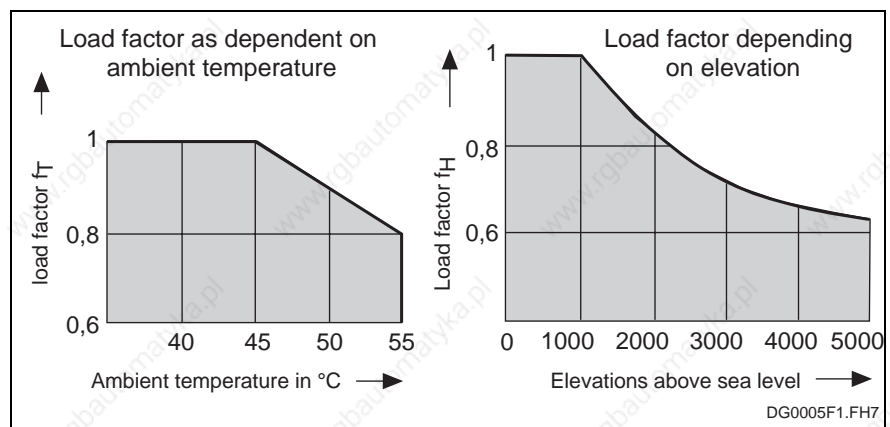

Fig. 7-1: Load factor as dependent on ambient temperature and elevation

Case 1:

The ambient temperature exceeds the nominal data

- or -

the elevation exceeds the nominal data:

1. Determine the load factor from the figure above.
2. Multiply the nominal data listed in the technical data with the load factor which has been determined.
3. Ensure that the derated nominal data is not exceeded by your application.

Case 2:

The ambient temperature exceeds the nominal data

- and -

the elevation exceeds the nominal data:

1. Determine the load factors from the figure above.
2. Multiply the determined load factors.
3. Multiply the nominal data indicated in the technical data by the load factor calculated in step 2.
4. Ensure that the derated nominal data is not exceeded by your application.

Protection category

The power supply unit meets the requirements as specified for protection category IP10, as per IEC 529.

Mounting of the power supply unit

It has been designed for mounting into a control cabinet or closed housing (as per EN 50 178, edition dated 4/98).

Note: Take the safety directives governing protection upon contact into account when laying out the control cabinet. For industrial applications, also see EN 60 204.

Loss of heat in the control cabinet

With HVE and HVR types, basic losses due to control voltages, power losses and probable bleeder losses arise. Basic, power and bleeder losses produce a loss of heat in the control cabinet and might not be carried off over the control cabinet surface. They need to be carried off by an air conditioning unit.

The bleeder power loss depends on the rotary drive energy, the potential energy of non balanced masses and the programmed machine cycle (see chapter 5.5).

In the following you'll find the calculation of a heat loss in the control cabinet. The data for the calculation stem from this documentation except for the motor data and the drive and control system data.

Example calculation

The arising losses of heat shall be calculated for the following drive equipment:

Units in the control cabinet

Power supply unit	HVR02.2-W010N , DC bus continuous power 10 kW; calculated load 8 kW
Combining filter and commutation choke	Combining filter HZF01.1-W010N , Commutation choke KD30
Drive 1	Motor 2AD104B-...-CS with drive controller HDS02.2-W040N Continuous power 5 kW; Motor constant current 12 A
Drive 2	Motor MHD093C-035 with drive controller HDS02.2-W040N Constant torque 23 Nm; Motor constant current 18,5 A
Drive 3	Motor MHD093C-035 with drive controller HDS03.2-W075N Constant torque 23 Nm; Motor constant current 12 A
Drive 4	Motor MHD112B-024 with drive controller HDS03.2-W100N Constant torque 28 Nm; Motor constant current 21,9 A

Basic losses and load dependent losses arise in the power supply unit, the choke, the combining filter and in the drive and control systems.

Basic losses

Type of unit	Designation	Basic loss [W]
Power supply unit	HVR02.2-W010N	150
Combining filter	HZF01.1-W010N	100
Commutation choke	KD30	150
Drive controller	HDS02.2-W040N	45*
Drive controller	HDS02.2-W040N	45*
Drive controller	HDS03.2-W075N	55*
Drive controller	HDS03.2-W100N	70*
Sum		615 W

*: Basic losses consist of the losses for the control voltage and the basic losses of the power supply.

Fig. 7-2: Basic losses of the units installed in the control cabinet

Load dependent losses

The calculation of load dependent losses is based on the fact that the DC bus is loaded with 8 kW (constant load) and the motor load corresponds to the respective motor constant torque or motor continuous power.

Note: It is advisable for main drive applications to start from each motor constant torque/motor continuous power.
If the calculated effective torque for the feeding application is smaller than the motor constant torque, the motor current can be reduced proportionally.

Type of unit	Designation	Load dependent losses [W]
Power supply unit	HVR02.2-W010N	8 kW * 15 W/kW = 120 W
Combining filter	HZF01.1-W010N	8 kW * 10 W/kW = 80 W
Commutation choke	KD30	8 kW * 15 W/kW = 120 W
Drive controller	HDS02.2-W040N	12 A * $\sqrt{2}$ * 5 W/A \approx 85 W ^{*1}
Drive controller	HDS02.2-W040N	18,5 A * 5 W/A \approx 93 W
Drive controller	HDS03.2-W075N	18,5 A * 4,625 W/A \approx 86 W
Drive controller	HDS03.2-W100N	21,9 A * 4,6 W/A \approx 101 W
Sum		685 W

^{*1}: With regard to asynchronous motors, the technical data include the effective value of the phase-to-phase current as motor nominal current. The loss factor (W/A) indicated in the technical data of the control units refers however to the peak value so that the motor nominal current is multiplied by $\sqrt{2}$.

Fig. 7-3: Load dependent losses of the units installed in the control cabinet

Total power loss

The total power loss in the drive package is:

Basic losses + load dependent losses =

$$615 \text{ W} + 685 \text{ W} = \underline{1300 \text{ W}} = P_{vGes}$$

As a rule, only part of the power loss may be carried off over the control cabinet surface. Then, it is necessary to use a cooling unit so that the remaining power loss may be carried off:

$$P_{Klima} = P_{vGes} - P_{surf} = P_{vGes} - [A * K * (45^\circ - T_{max})]$$

- P_{vGes}: Total power
- P_{Klima}: Power to be carried off via cooling unit [W]
- P_{surf}: Power carried off over control cabinet surface [W]
- A: Isolated control cabinet surface [m²]
- K: Heat transmission coefficient (approx. 5 ... 6 W/m²)
- T_{max}: Maximum ambient temperature

Fig. 7-4: Calculation of the power loss to be carried off via cooling unit

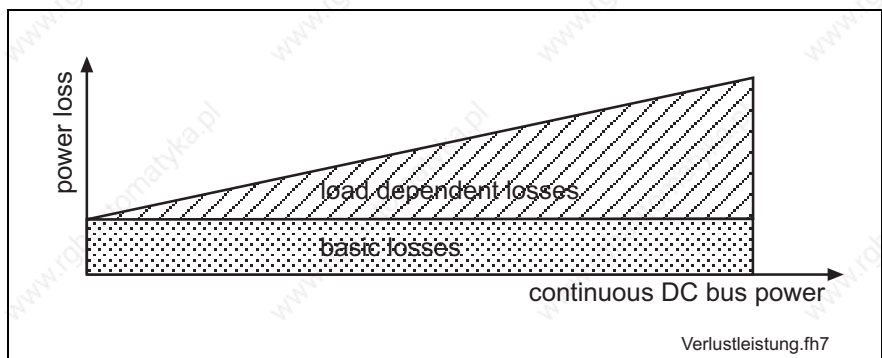

Fig. 7-5: Power loss depending on the DC bus continuous power

The use of cooling units

The power supply unit with reduced nominal data may only be operated up to an ambient temperature of 45 °C. This means that it may be necessary to use a cooling unit.

Avoid dripping and spraying water

The use of cooling units always means that condensation will occur!



CAUTION

When using cooling units, damages to the power supply unit may be caused by condensation water!

- ⇒ Always arrange the cooling units so that condensation cannot drip into or onto electronic equipment.
- ⇒ Position cooling units so that the cooling unit blower does not blow condensation which has possibly collected onto electronic equipment.

Note: For the arrangement of a cooling unit please see the following figures too.

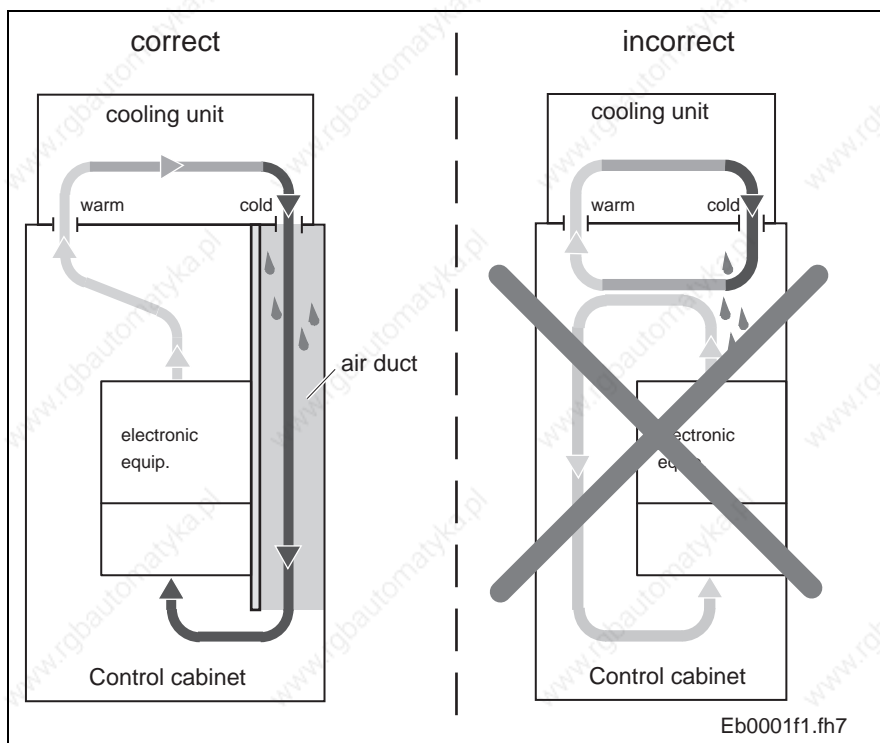

Fig. 7-6: Cooling unit arrangement on the control cabinet

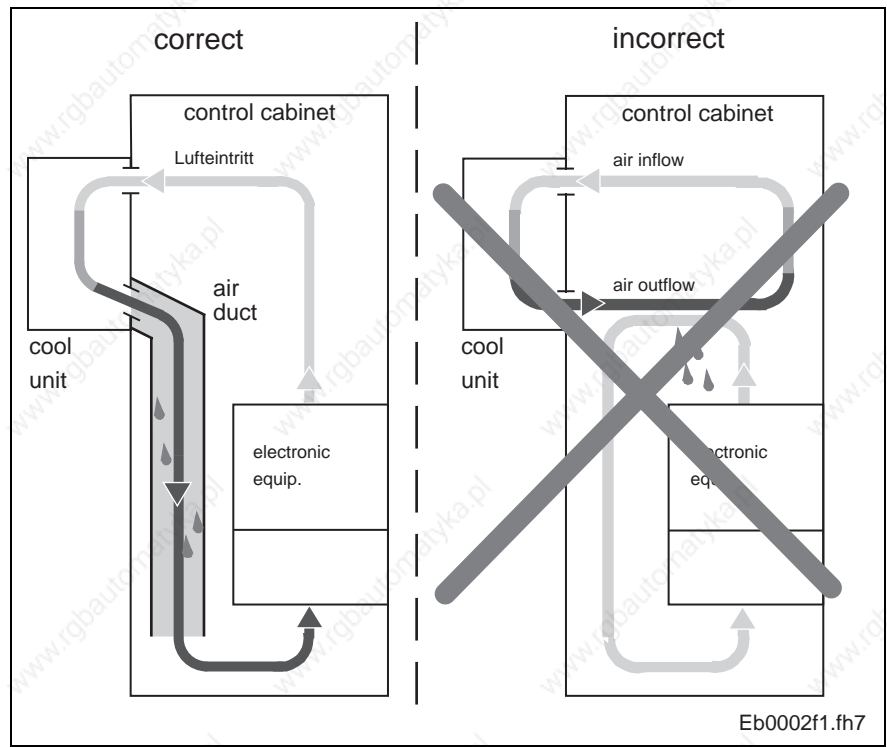

Fig. 7-7: Cooling unit arrangement on the front of the control cabinet

Avoiding condense water

**CAUTION****When using cooling units, damages to the power supply unit may be caused by condensation water!**

- ⇒ Set the cooling units at 40° C and no lower!
- ⇒ Set cooling units with follow-up temperature in such a way that the inside temperature of the control cabinet does not drop below the outside temperature. Set the temperature limit to 40° C!
- ⇒ Use only well sealed control cabinets in order to avoid condense water due to incoming humid outside air.
- ⇒ If the control cabinets are operated with open doors (during servicing or start ups), then ensure that the controllers are never cooler than the air within the control after the doors are closed as otherwise condensate could form. For this reason, continue to run the cooling unit even when the machine is shutdown until the temperature of the air in the control cabinet and that of the installed units is the same.

Construction of uncooled control cabinets

During operation of the units, power losses occur which heat the surrounding air in the control cabinet. If a power supply unit is operated in an uncooled and unventilated control cabinet, sufficient clearance must be provided around the unit or the drive package (at least 300 mm to the top and 100 mm to the sides). This clearance is necessary in order to produce an air circulation in the control cabinet (see also the next figure).

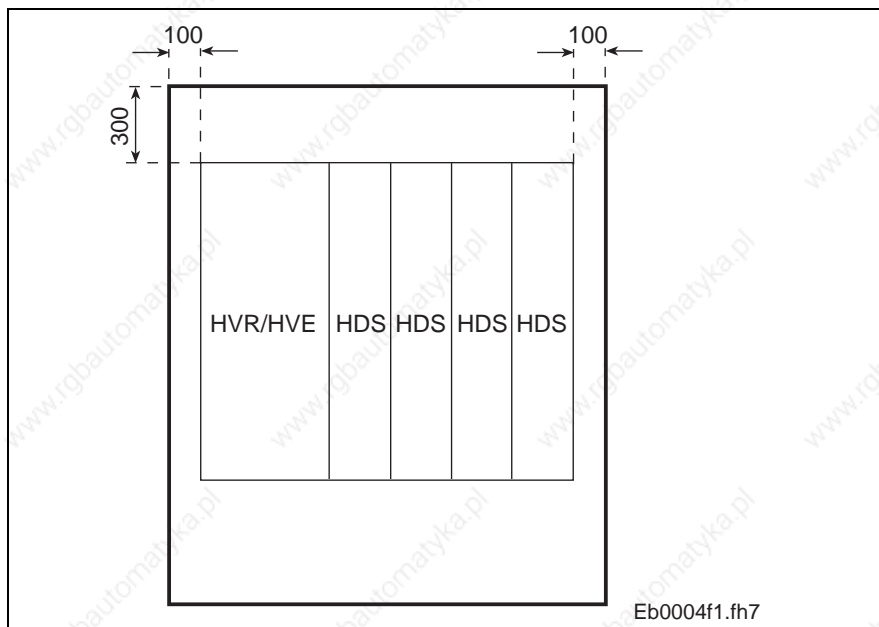

Fig. 7-8: Control cabinet (uncooled, unventilated) with drive package

**CAUTION**

Damage to the units due to too high temperatures!

⇒ Ensure air circulation within the control cabinet air by means of a circulation system. If circulation within the cabinet is not forced, then layers of air are generated within the cabinet the temperature of which depends on how close the layer is to the top of the cabinet, i.e., the closer the hotter. Without air circulation the air near the source of the heat continues to grow hotter to the point where extreme temperatures could occur. These temperatures can then damage the unit permanently.

Note: The cooling units inside the unit only cool internally. They do not have enough power to generate air circulation within the cabinet.

Efficiency factor of the air circulation system

The greatest effect is achieved if the air channel is conducted along an outside wall of the control cabinet so that the outside surface is used as a cooling surface. The blowers must blow upward. This may counter natural convection and the blowers internal blower, but it effects the rapid movement of cooler air out of the lower part of the cabinet into the upper, hotter layer of air thus countering pockets of heat very effectively.

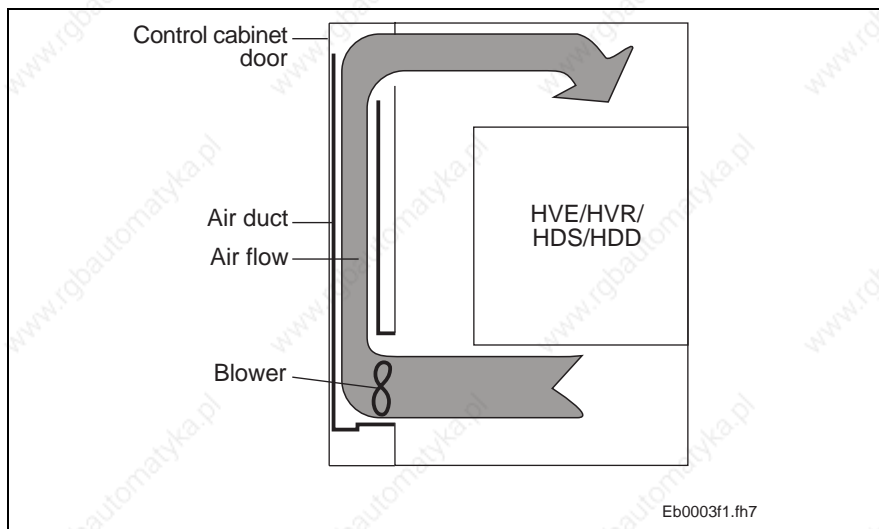

Fig. 7-9: Control cabinet with air circulation system

7.2 Mounting an HVE or HVR into the control cabinet

Mounting conditions

The power supply units HVE and HVR and their controllers are designed to be mounted into a control cabinet or closed housing. They meet the demands of protection category IP 10, as per IEC 529; i. e. the unit is protected against the ingress of objects with a diameter exceeding 50 mm.

It is not protected against

- water and
- intentional accessing, e.g., with a hand, but will keep larger body parts and surfaces out.

Mounting position The unit is to mount in such a way that the mains connection is located at the bottom.



CAUTION

Damage to the units due to faulty mounting!

⇒ Install the unit as it is shown in the front views (chapter 7.4) so that the unit is prevented from overheating and damage due to faulty mounting.

Controller arrangement Place those drives with high power and high currents as close to the supply unit as possible. Ideally, the axes should be distributed symmetrically on the left and right.

Given a total power of $P_{mges} > 36 \text{ kW}$ the axes must be arranged in accordance with their power equally on both the left and right sides (exception: single axis with $P_m > 36 \text{ kW}$).

Maximum number of axes The maximum number of axes is limited by the drive power of the control signals at X1

- and/or -

by the maximum power of the control voltage outputs of the unit (X8).

- Driver power of control signals: max. 12 axes
- Power of control voltage output: 300 W

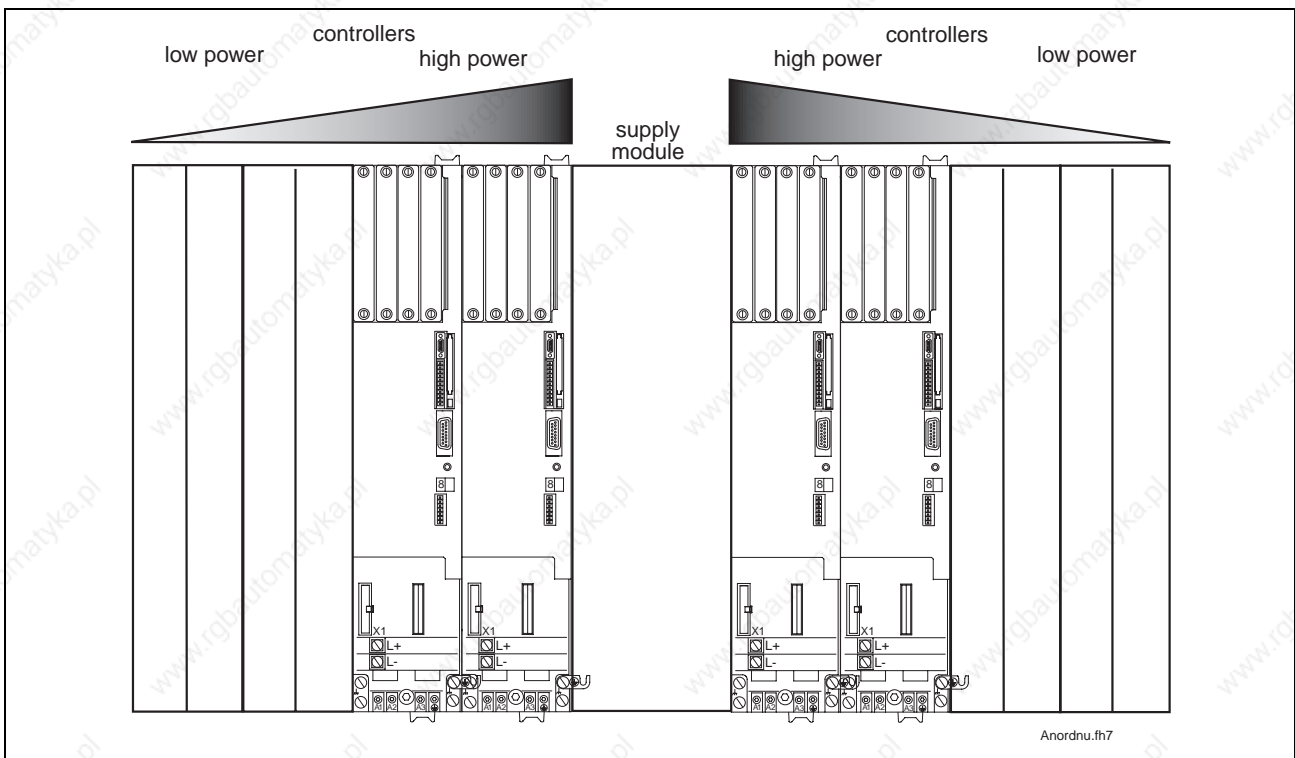

Fig. 7-10: Recommended unit arrangement within the control cabinet

Safety distance of the bleeder resistor

The bleeder resistor in the HVE heats up during operation, in the HVR after power shutdowns. Materials which could be damaged by heat, such as lines and cable ducts, must have a minimum clearance of 300 mm to the top and 40 mm to the side and front.

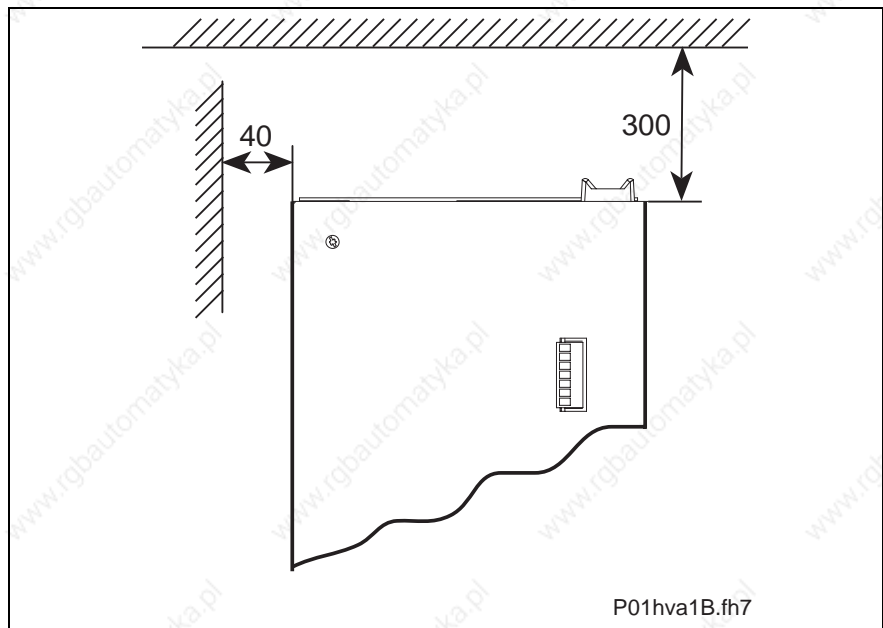

Fig. 7-11: Safety distance of the bleeder resistor

7.3 Optimal EMC installation

With regard to an optimal EMC installation, a spatial separation of the interference-free area (mains connection) and the interference susceptible area (drive components) is advisable. See the next figure in this respect.

Note: For an optimal EMC installation see also the connection hints (chapter 8.9 "Interference elimination").

HVE

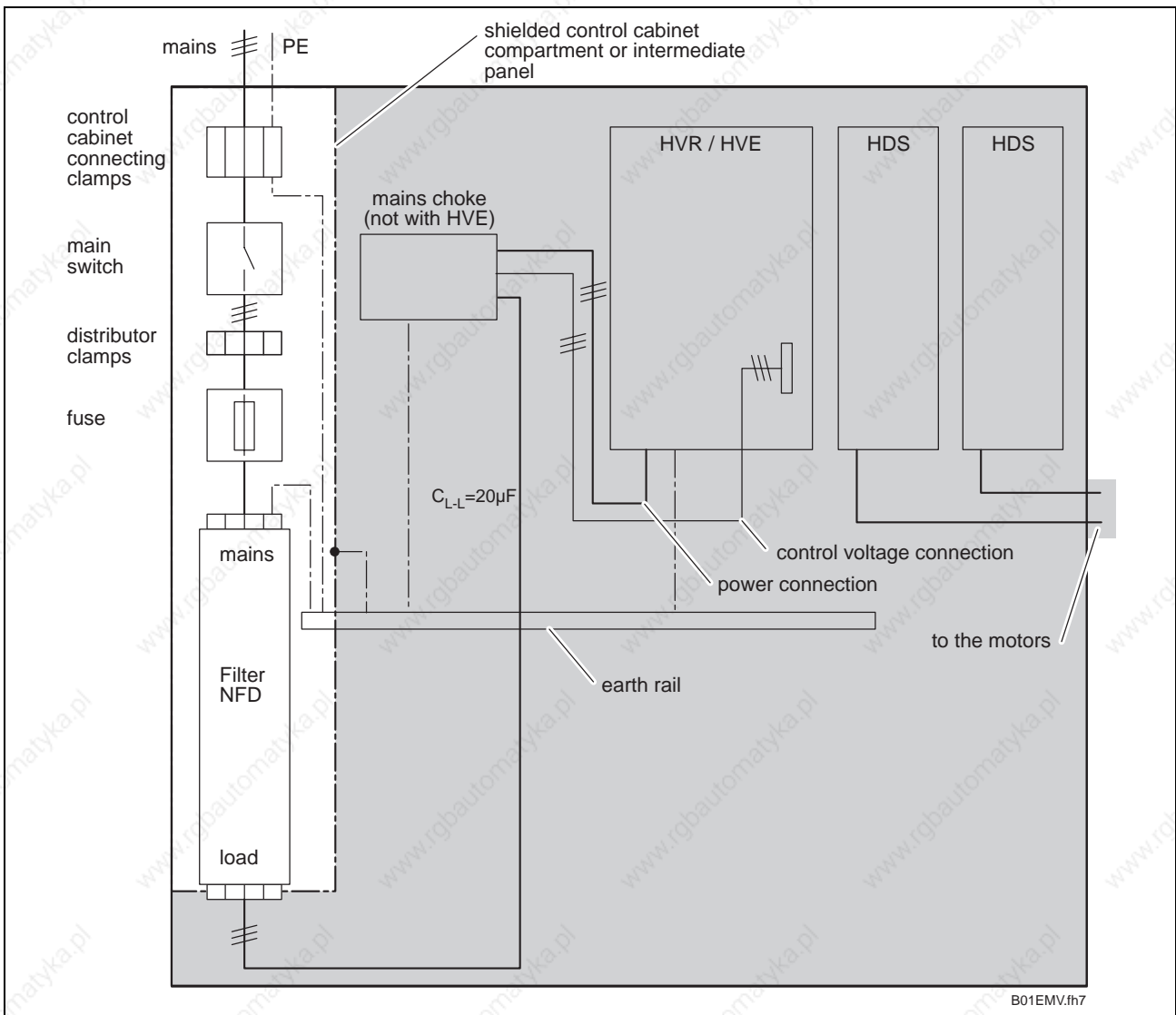

Fig. 7-12: HVE - Separation of interference-free and interference susceptible areas

HVR

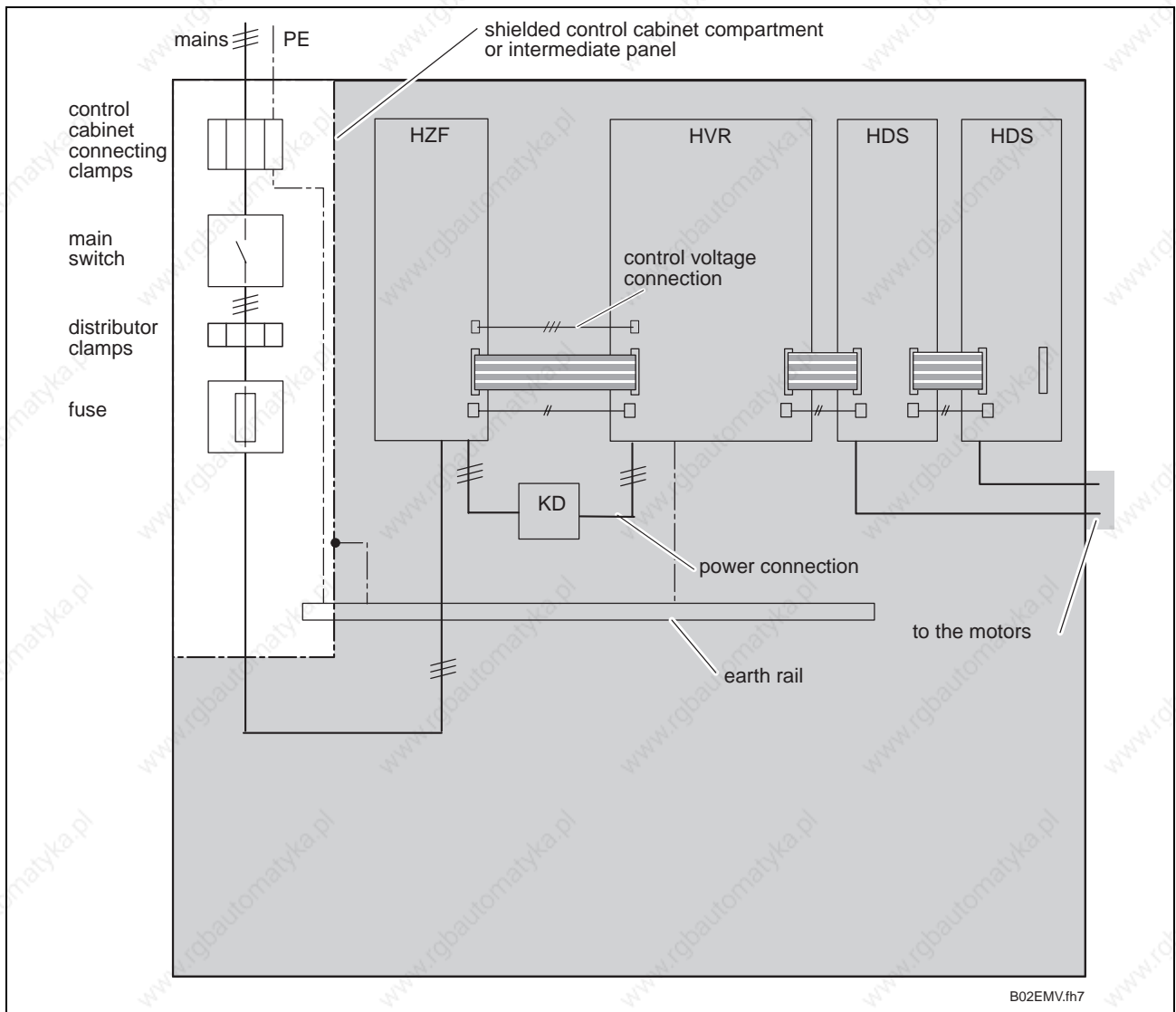

Fig. 7-13: HVR - Separation of interference-free and interference susceptible areas

7.4 Dimensional data

HVE02.2 and HVE03.2

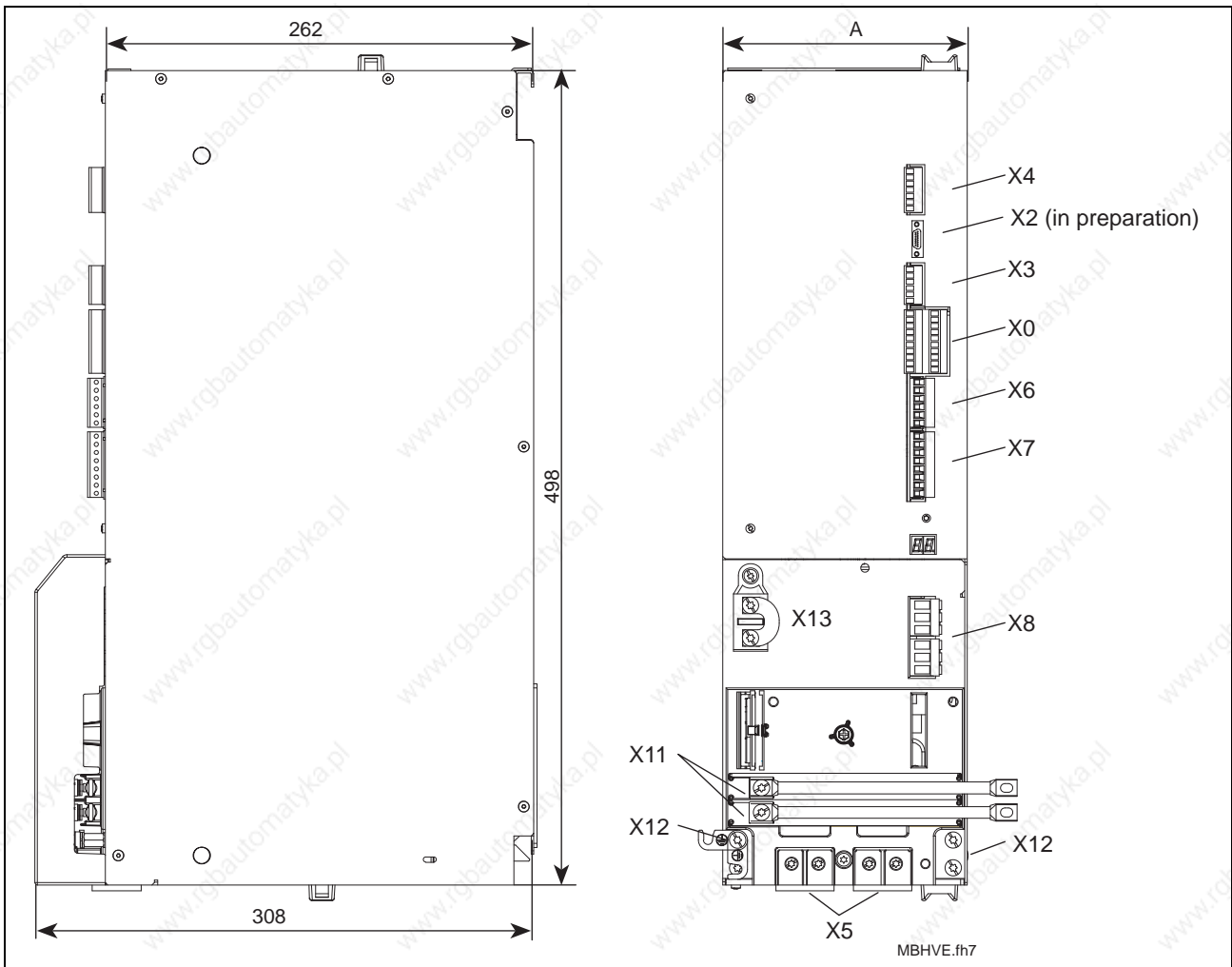

Fig. 7-14: Dimension drawings HVE02.2 and HVE03.2

Unit width A Unit types HVE02.2 have a width of 100 mm;
 Unit types HVE03.2 have a width of 150 mm

Type	Terminal designations									
	X1	X3	X4	X5	X6	X7	X8	X11	X12	X13
HVE02.2	*1	1,5	1,5	16	2,5	2,5	4	*2	*2	*2
HVE03.2	*1	1,5	1,5	35	2,5	2,5	4	*2	*2	*2

*1: Flat cable firmly connected to the unit and/or free multiple contact strip for looping through the X1-connections

*2: This wiring material will be supplied

Fig. 7-15: Maximum cross sections for connection [mm²]

HVE04.2

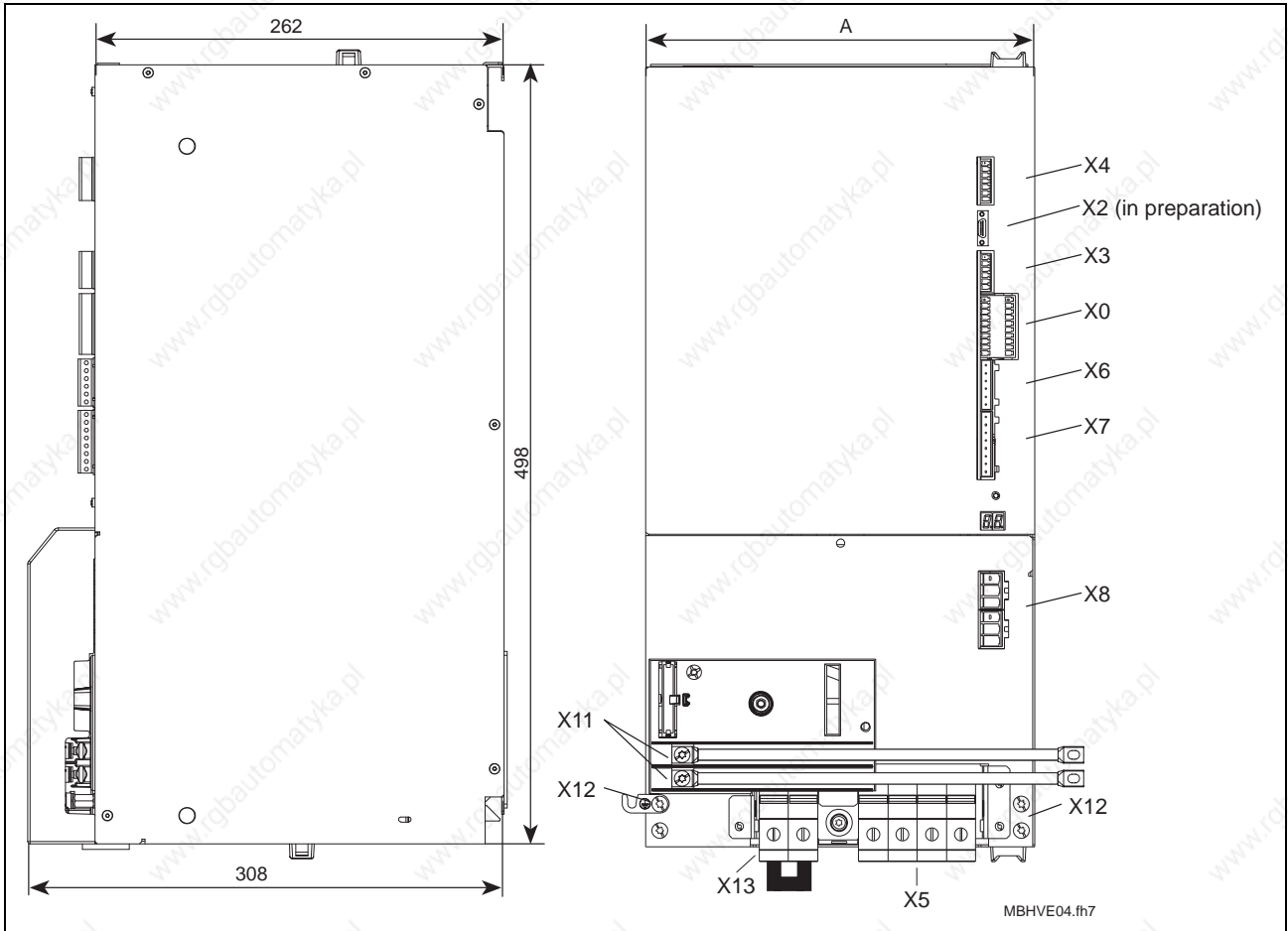

Fig. 7-16: Dimension drawing HVE04.2

Unit width A Unit types HVE04.2 have a width of 250 mm.

Type	Terminal designations									
	X1	X3	X4	X5	X6	X7	X8	X11	X12	X13
HVE04.2	*1	1,5	1,5	50	2,5	2,5	4	35	*2	50

*1: Flat cable firmly connected to the unit and/or free multiple contact strip for looping through the X1-connections
 *2: This wiring material will be supplied

Fig. 7-17: Maximum cross sections for connection [mm²]

HVR

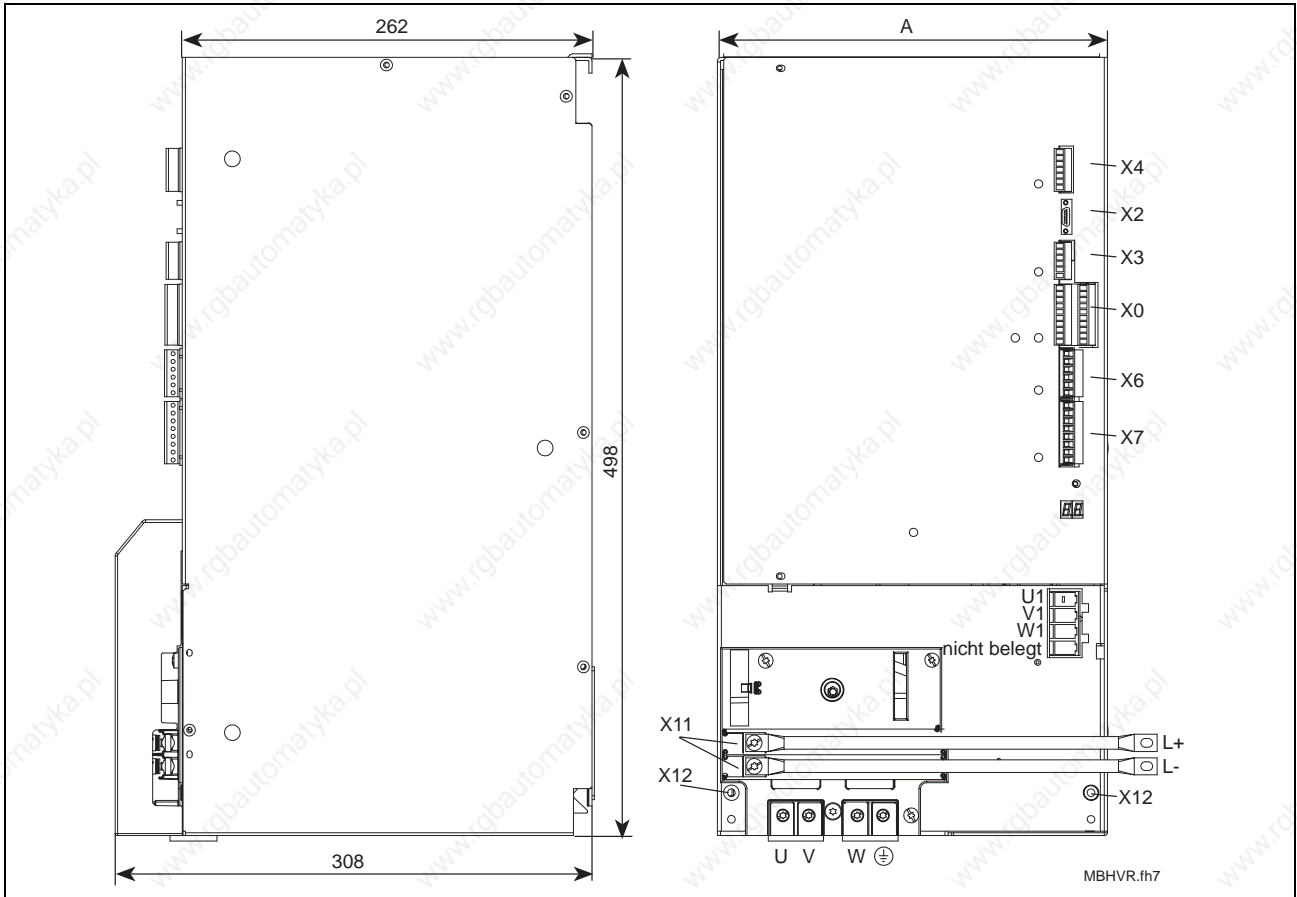

Fig. 7-18: Dimension drawing HVR

Unit width A Unit types HVR02.2 have a width of 175 mm ;
 Unit types HVR03.2 have a width of 250 mm

Type	Terminal designations								
	X1	X3	X4	X5	X6	X7	X8	X11	X12
HVR02.2	*1	1,5	1,5	16	2,5	2,5	4	*2	*2
HVR03.2	*1	1,5	1,5	35	2,5	2,5	4	*2	*2

*1: Flat cable firmly connected to the unit and/or free multiple contact strip for looping through the X1-connections
 *2: This wiring material will be supplied

Fig. 7-19: Maximum cross sections for connection [mm²]

HZF01.1-W010N

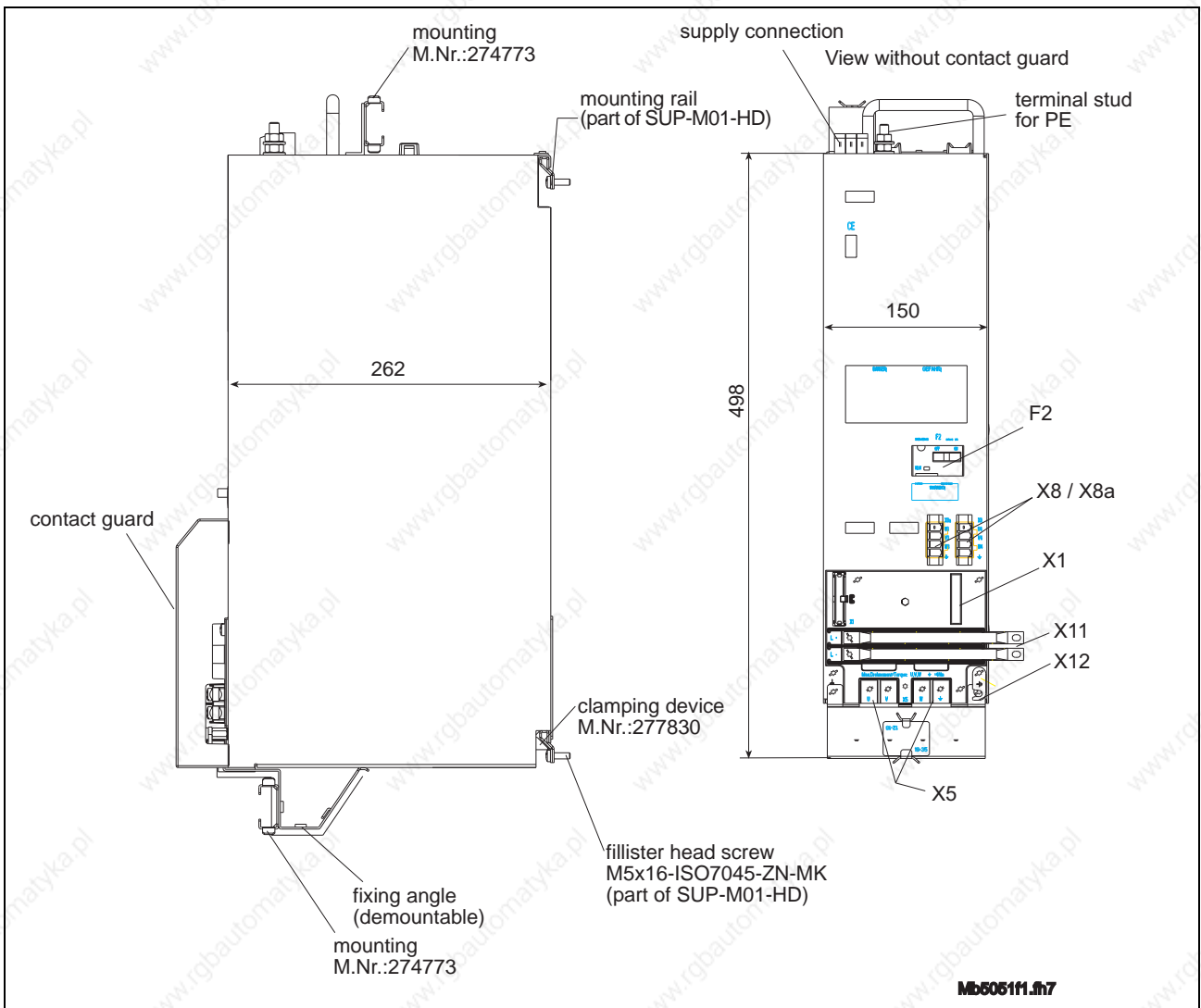

Fig. 7-20: Dimension drawing HZF01.1-W010N

Supply connection	Terminal designations				
	X1	X5	X8	X11	X12
4	*1	6	1,5	*2	*2

*1: Flat cable firmly connected to the unit and/or free multiple contact strip for looping through the X1-connections

*2: This wiring material will be supplied

Fig. 7-21: Maximum cross sections for connection [mm²]

HZF01.1-W025N / HZF01.1-W045N

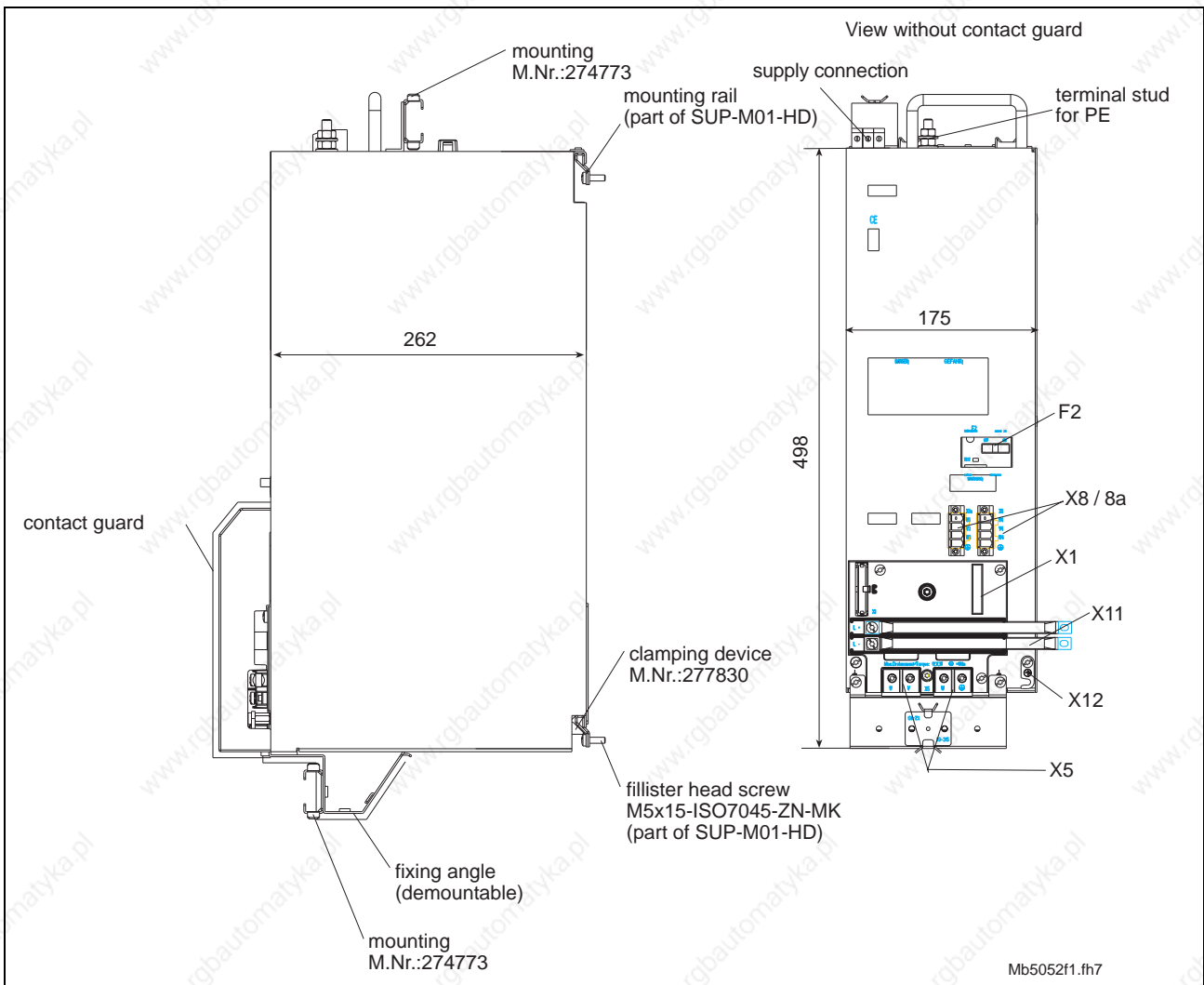

Fig. 7-22: Dimension drawing HZF01.1-W025N / HZF01.1-W045N

Type	Terminal designations					
	Supply connection	X1	X5	X8	X11	X12
HZF01.1-W025N	16	*1	16	1,5	*2	*2
HZF01.1-W045N	25	*1	25	1,5	*2	*2

- *1: Flat cable firmly connected to the unit and/or free multiple contact strip for looping through the X1-connections
- *2: This wiring material will be supplied

Fig. 7-23: Maximum cross sections for connection [mm²]

Commutation choke KD xx

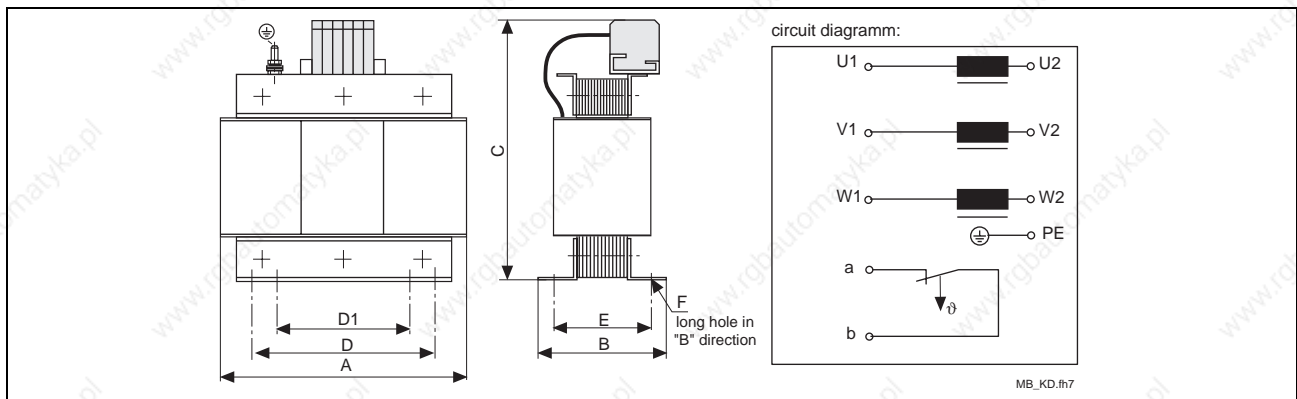

Type	Dimensions [mm]								Terminal cross section [mm ²]	Weight [Kg]
	A	B	C	D	D1	E	F	⊕		
KD 30	180	225	205	125	-	76	7X15	M5	10	8
KD 27	285	138	280	170	110	108	11X18	M6	16	22
KD 28	330	160	390	230	180	130	10X18	M8	35	42

Fig. 7-24: Dimension drawing commutation choke KD xx

7.5 Mounting the unit

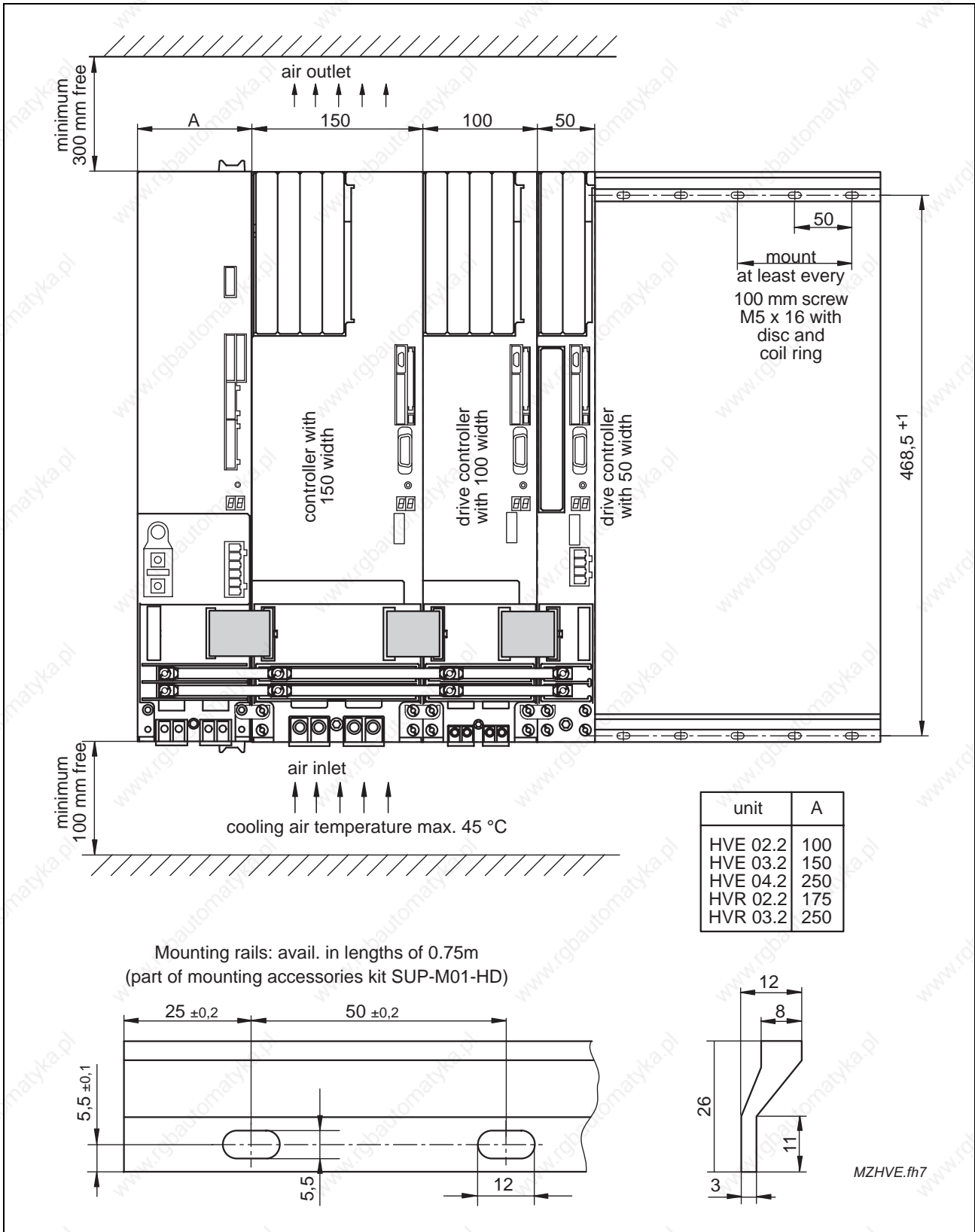

Fig. 7-25: Mounting the unit

Notes

8 Electrical connection

8.1 Introduction

Note: This chapter includes recommendations of how to install the unit (by Rexroth Indramat as the manufacturer).
The manufacturer's circuit diagram is decisive for the installation of the unit!

Note: For the maximum cross sections of the connection lines please see the following chapters:
Units HVE, HVR, HZF and KD: 7.4 "Dimensional data".
Units GLD, HZB and HZK: 6 "Auxiliary components".

8.2 Front view and terminal diagram

HVE

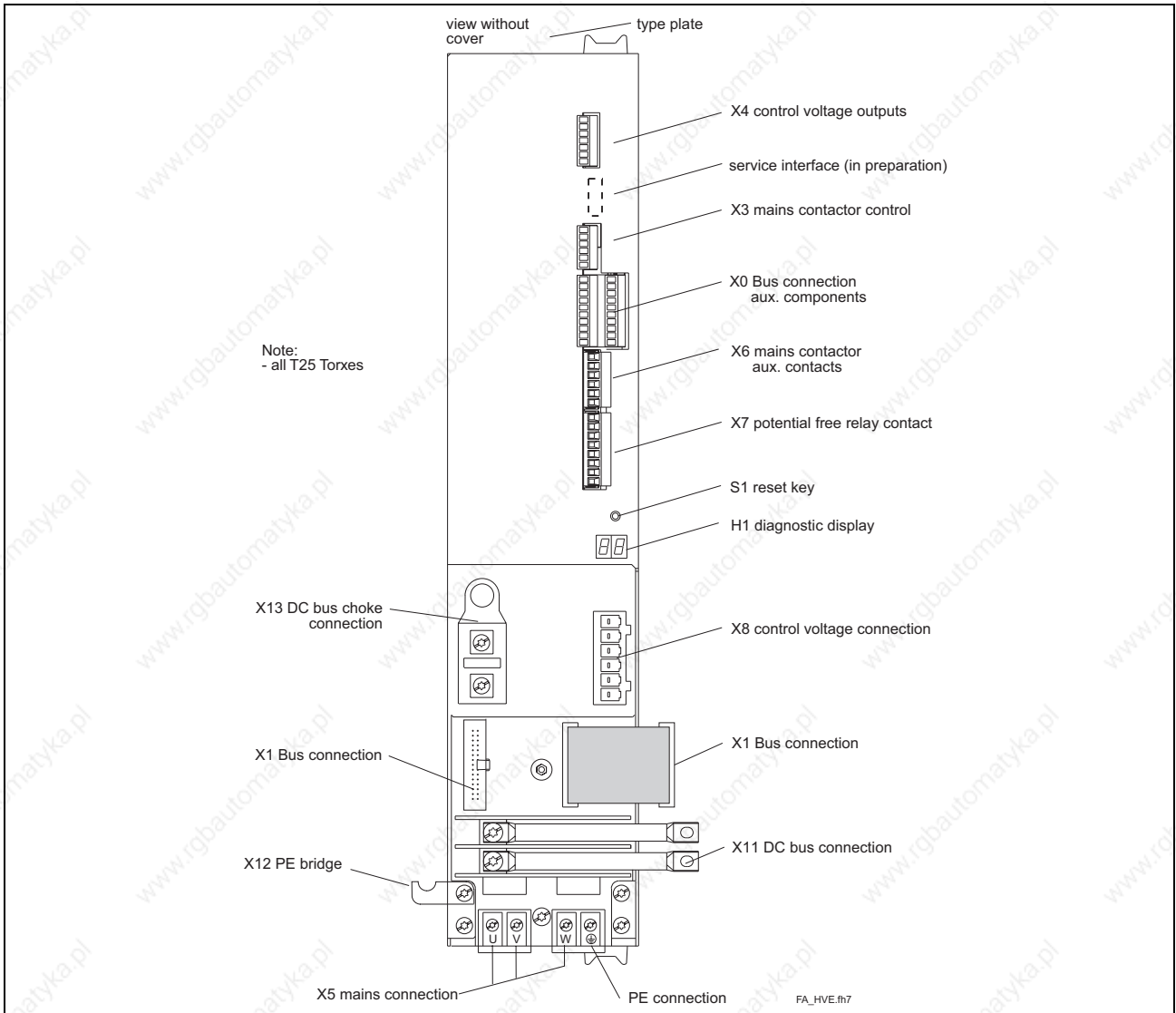

Fig. 8-1: Front views HVE02.2 and HVE03.2

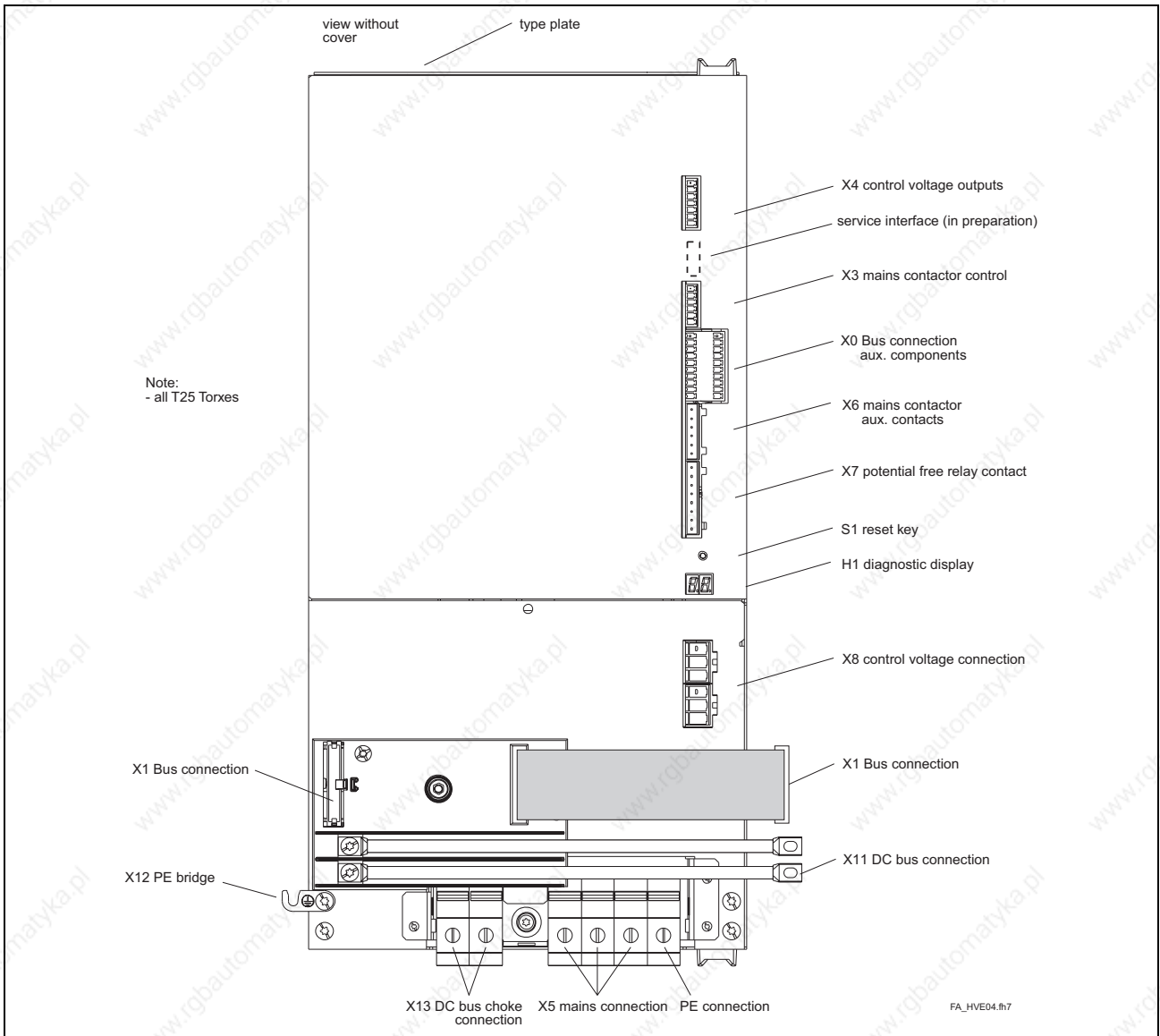

Fig. 8-2: Front view HVE04.2

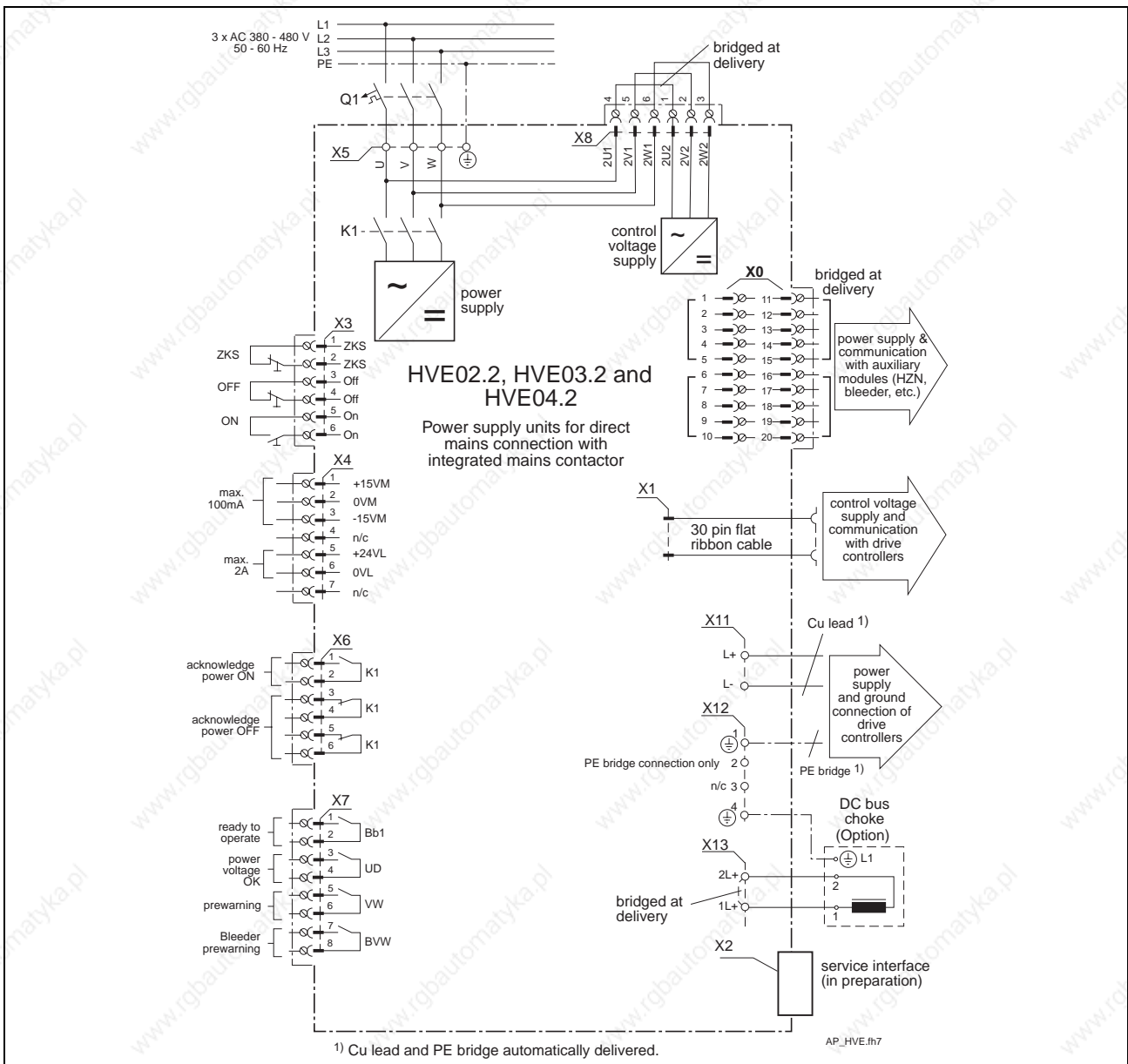

Fig. 8-3: Terminal diagram HVE02.2, HVE03.2 and HVE04.2

HVR

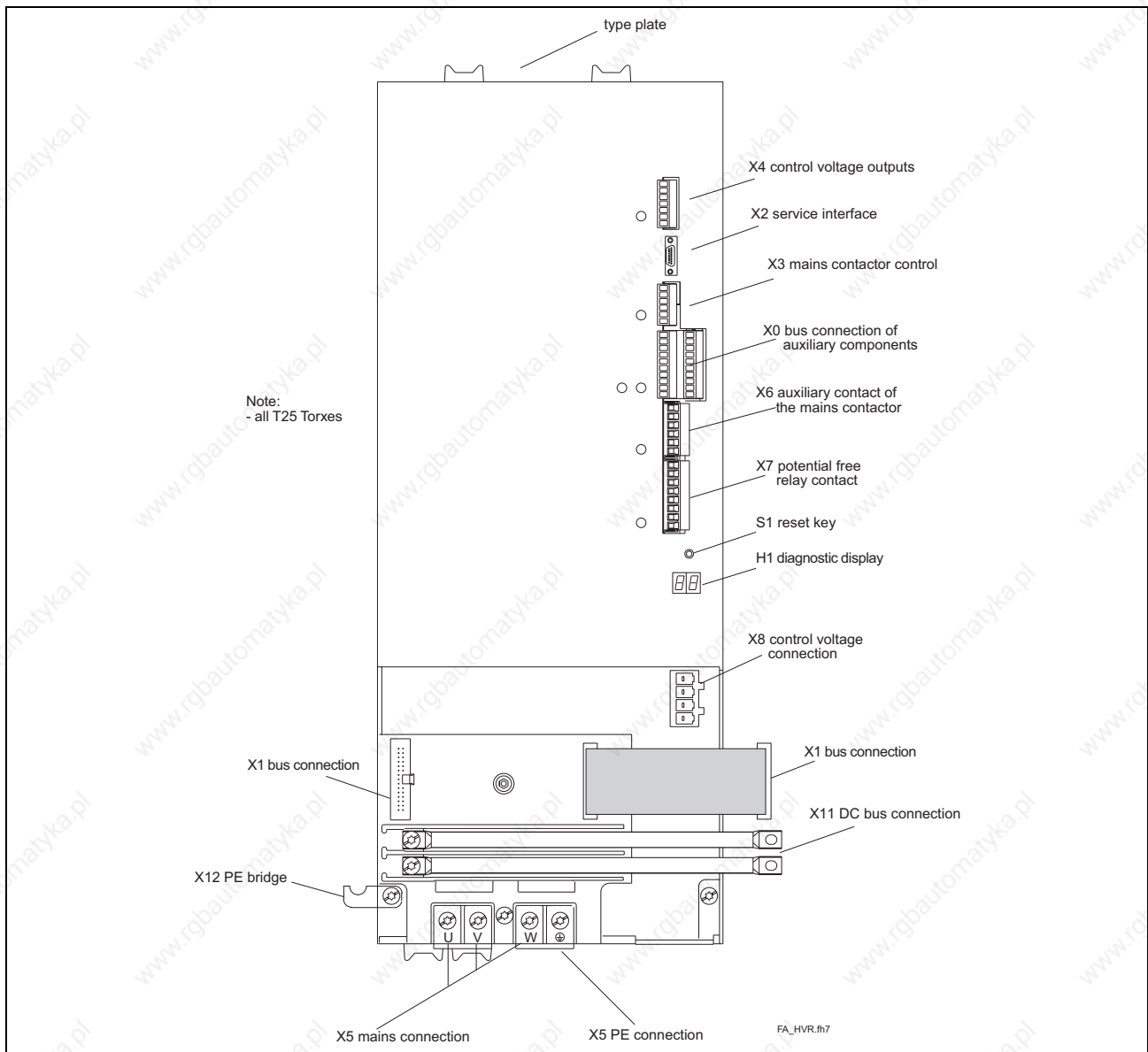

Fig. 8-4: Front view HVR

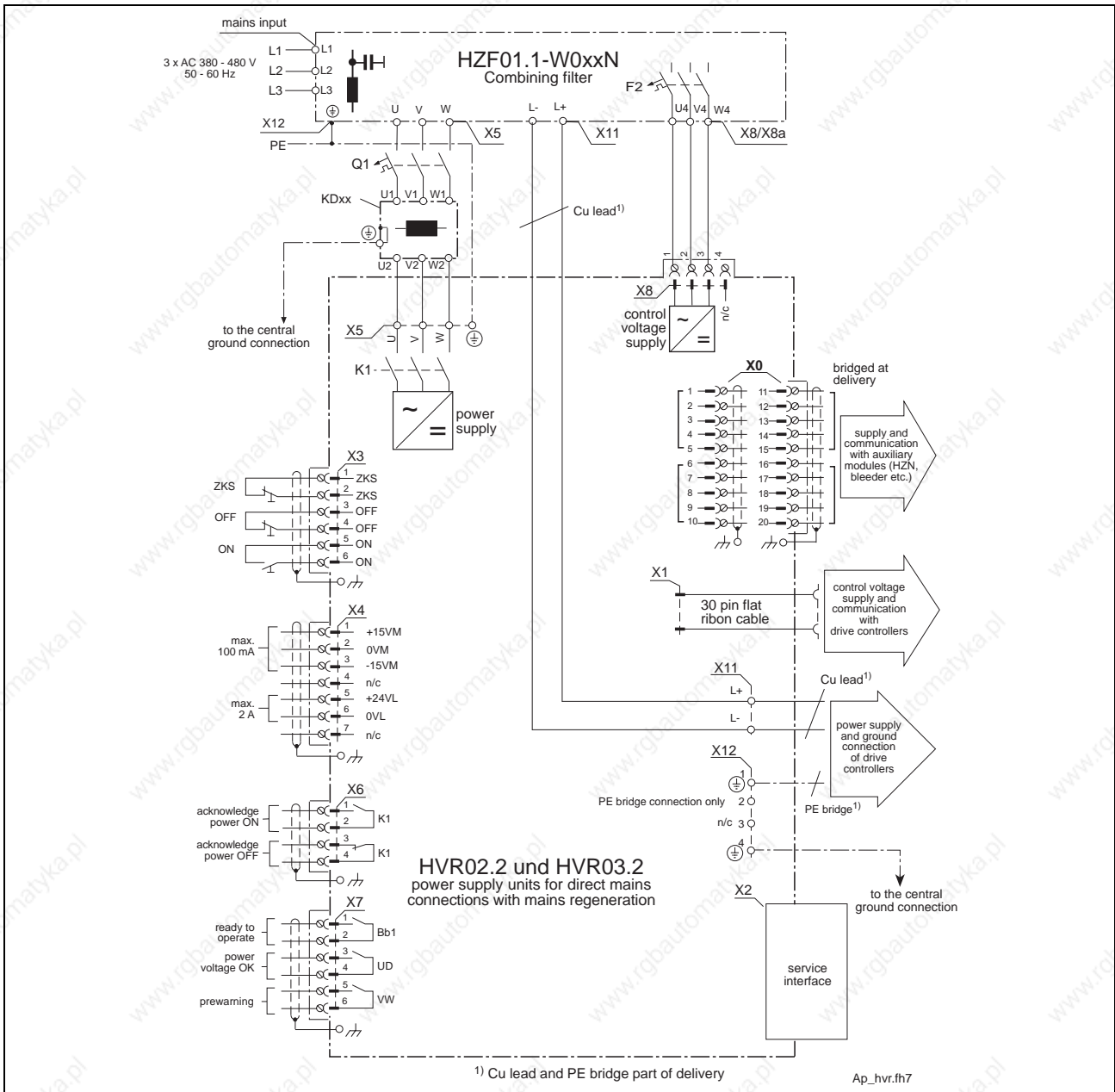

Fig. 8-5: Terminal diagram for HVR02.2 and HVR03.2

Note: Use a twisted cable for the wiring of the commutation choke!

HZF

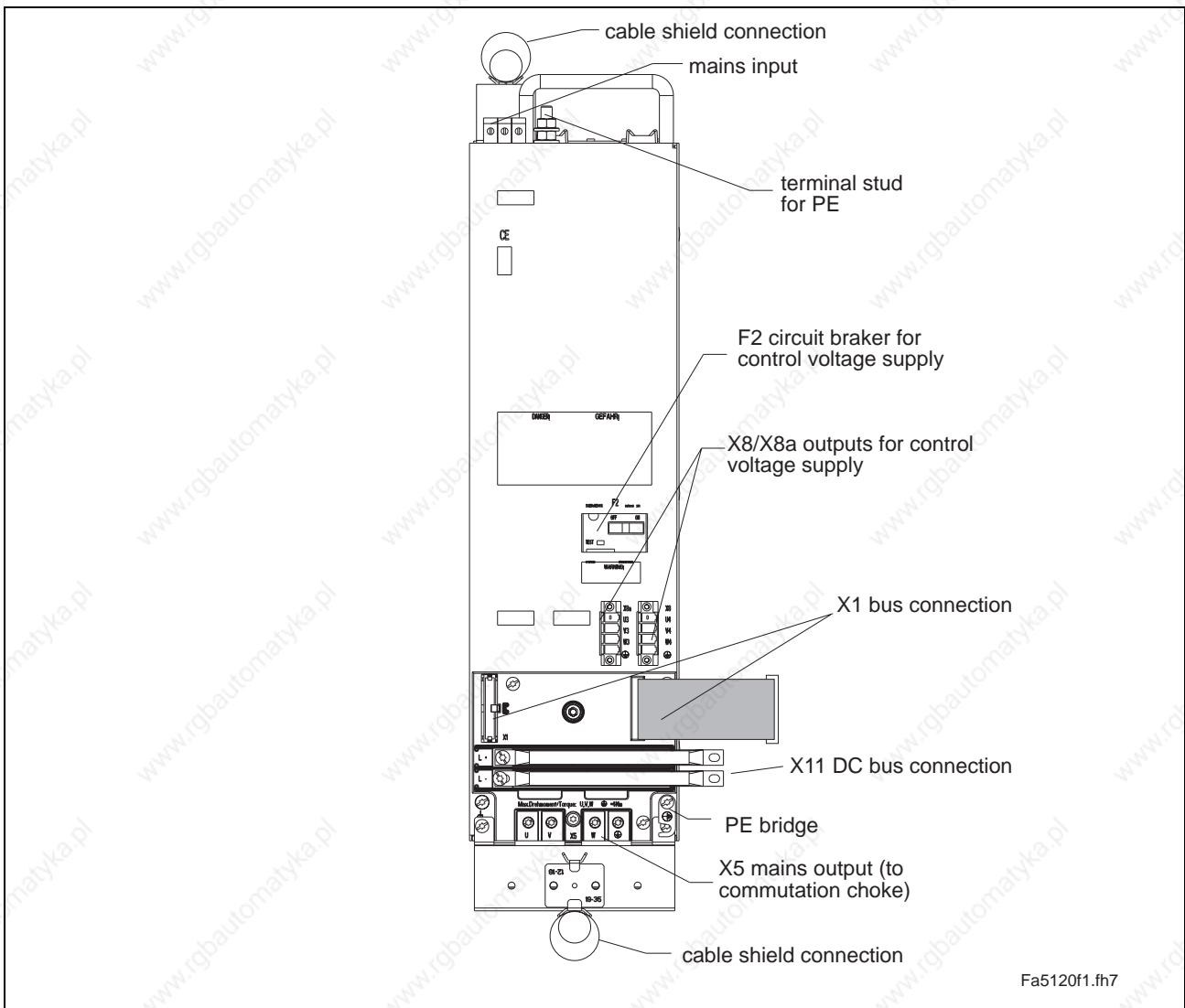

Fig. 8-6: Front view HZF

Note: For the connection of the combining filter HZF see the terminal diagram of the HVR power supply units.

8.3 Mains connection

General



WARNING

The leakage current via the protective conductor is greater than 3,5 mA!

⇒ To avoid electrical shocks when touching the protective conductor operate the supply unit only with a firm mains connection and always with the protective conductor connected.

Direct mains connection

Power supply units of the HVE and HVR line can be connected to grounded three-phase mains with 3 x AC 380 ... 480 V ($\pm 10\%$); 50 ... 60 Hz (± 2 Hz) without the need of a transformer.

Mains fuse protection with direct mains connection

For more information about the subject "Mains fuse protection with direct mains connection" read the recommendations in chapter 1317704.1315128.

Connecting the mains via a transformer

A transformer is needed if the mains voltage is smaller than 380 V or greater than 480 V.

The required transformers power must be equal to or greater than the incoming power (see chapter Service & Support "Service & Support").

Note: The mains inductance (leakage inductance) of transformers varies dependent upon power and type.

(Mains) voltage cutoff

If no additional capacitance is used, the supply voltage can be cut off for 3 ms in case of nominal load and 3 x AC 380 V mains voltage. More than 1 second should have passed between successive voltage cutoffs.

(Mains) voltage drop-outs

With 3 x AC 380 V mains voltage, the supply voltage may drop-out by 20% of the peak voltage for a maximum of 10 ms (in case of higher supply voltages proportionally more). More than 1 second should have passed between successive voltage drop-outs.

Interference suppression

Note: When operating modular drives in residential or light industrial areas, it may be necessary to mount an interference suppression filter in the power line in order to be able to maintain the limits for interference transmission (interference suppression).

HVE

Direct mains connection [with 3 x AC 380 ... 480 V ($\pm 10\%$)]

Power supply

In case of mains voltages with 3 x AC 380 ... 480 V ($\pm 10\%$) the power supply unit can be connected directly to the mains; no other components are necessary.

Note: For interference suppression we recommend a line filter NFD02.x.

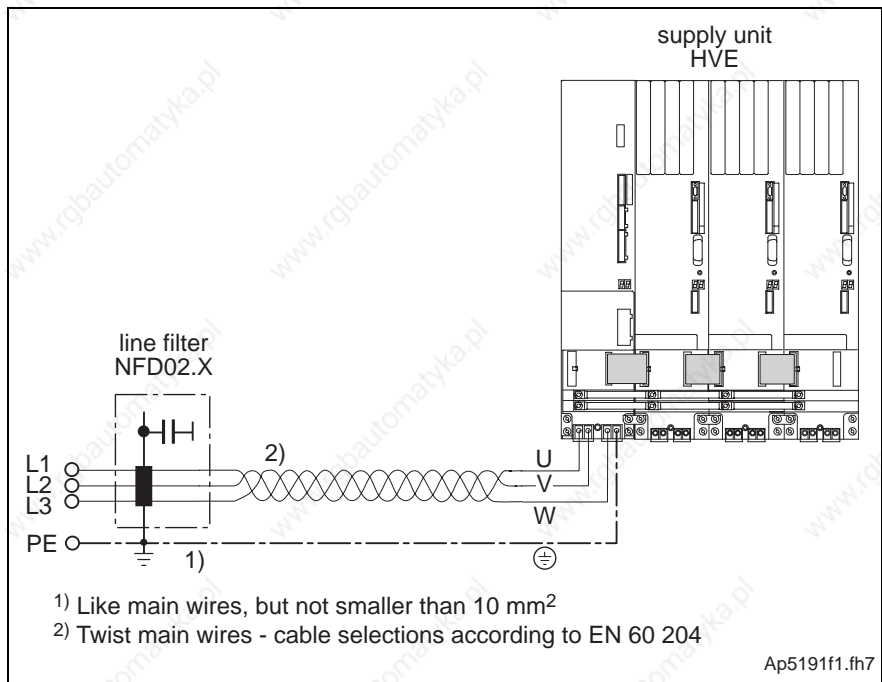

Fig. 8-7: Direct mains connection via line filter NFD02.x

Connecting the mains via autotransformer (with mains voltages < 3 AC x 380 V e.g. > 3 AC x 480 V)

If mains voltages are smaller than 3 AC x 380 V respectively greater than 3 AC x 480 V, it is necessary to use a transformer. To avoid earth leakage currents by system perturbations, high heat losses and autotransformer overvoltages, three capacitors in wye connection must be mounted as shown in the next figure.



Abb. 8-8: Mains connection via autotransformer

Control voltage supply

Note: When the units are delivered, the mains connections of the power and control voltage supply are bridged. Therefore no additional mains connection is required for the control voltage supply.

If special cases of application require a separate control voltage supply (e.g. to be able to save the diagnosis of the HVE upon shutdown of the power supply), the bridges between power and control voltage supply must be removed.

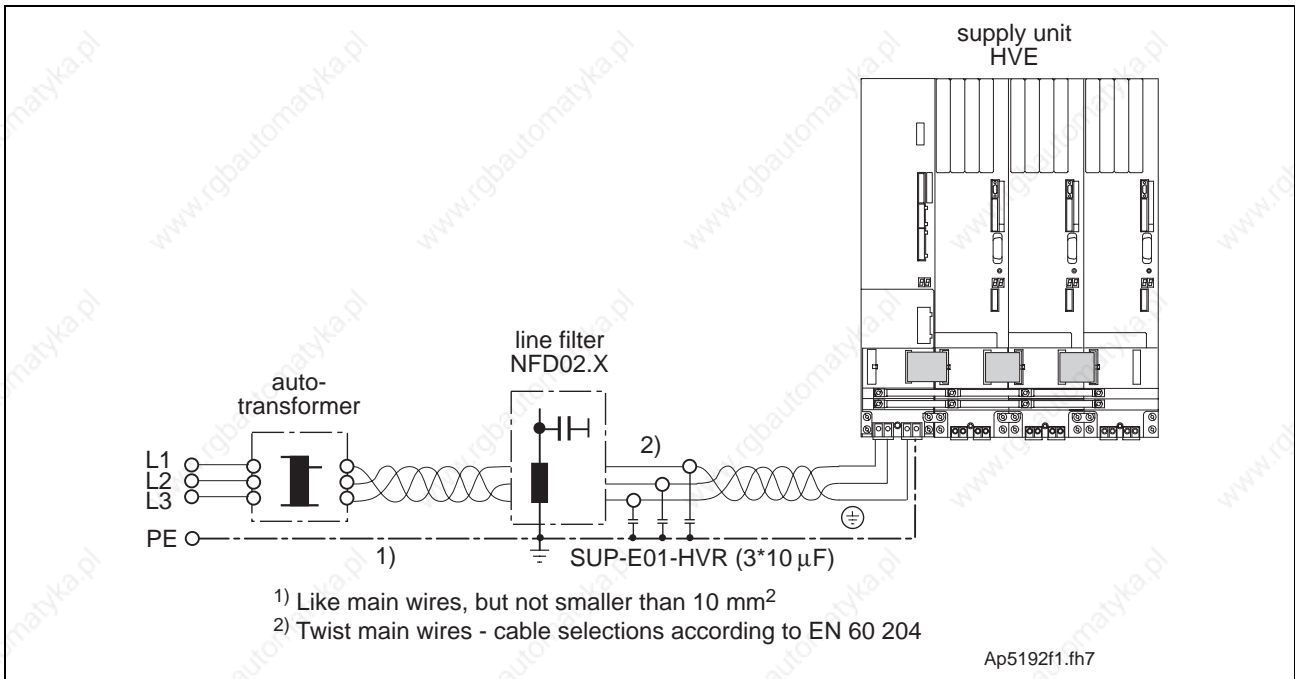
It is necessary to provide a short-circuit protection for the connection line of the control voltage (e.g. power circuit breaker 3VU1300-.MJ00, 2,6 ... 4 A; Siemens).

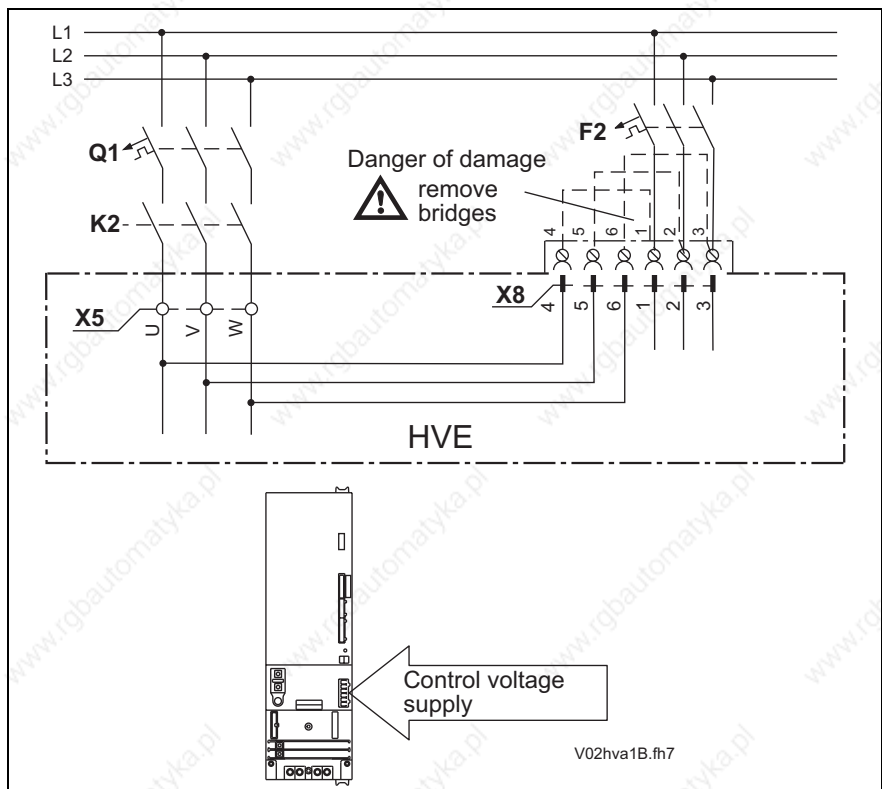

Fig. 8-9: Separate control voltage sources for the HVE

HVR

Power supply

**Mains connection with
3 x AC 380 ... 480 V ($\pm 10\%$)**

As the power part of the HVR power supply units consists of a clocked 3-phase IGBT bridge, a commutation choke KDxx will always be needed for the mains connection. In addition, a so-called combining filter HZF01.1-W0xxN will be required.

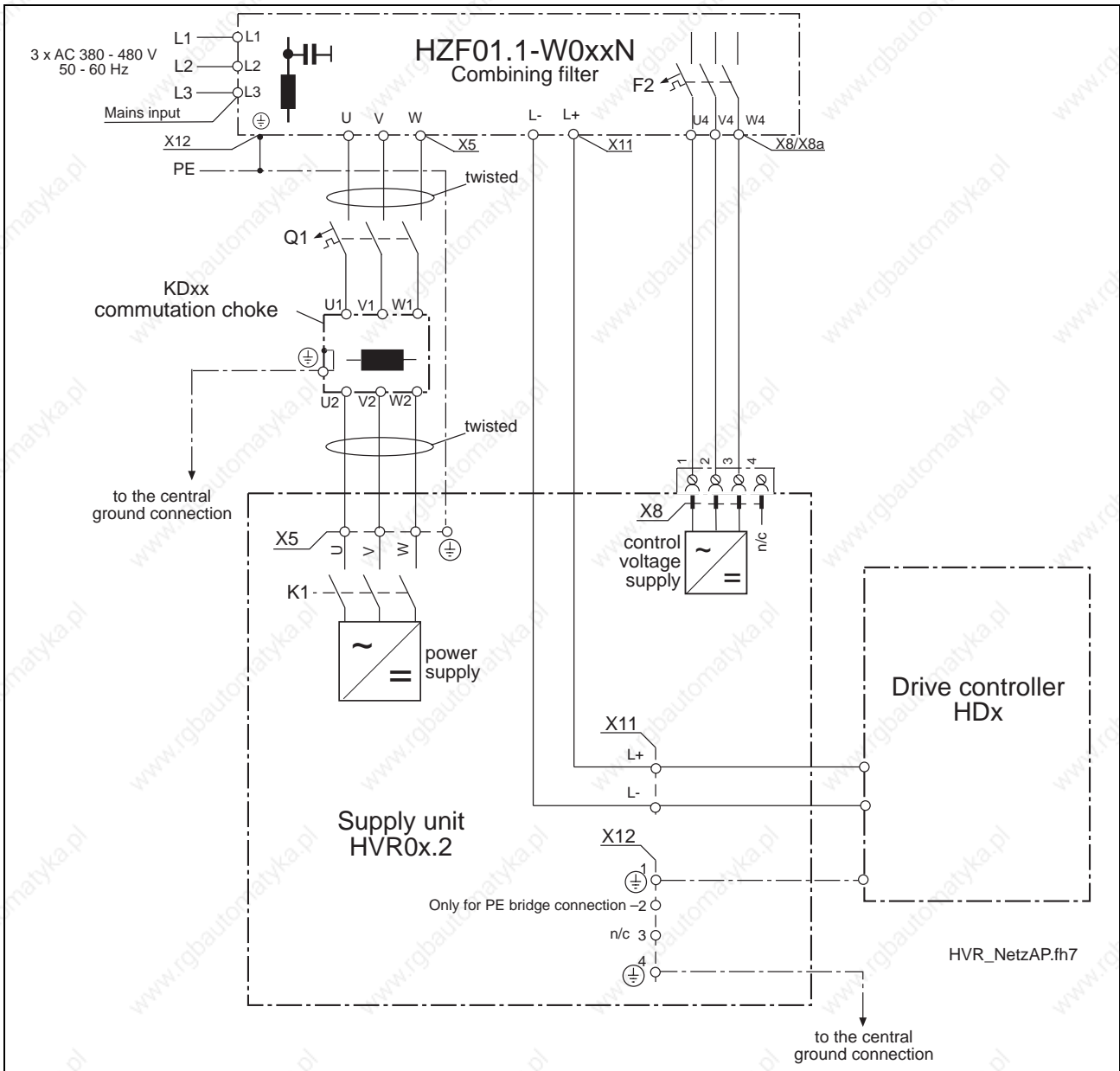

Fig. 8-10: HVR: Mains connection via commutation choke and combining filter

Basically, the HZF combining filters to be provided for the mains connection of the power supply units have two tasks:

- to suppress the current leakages from parasitic capacities of the construction (motor cable, winding capacities) and
- to ensure a sufficient interference suppression.

The combining filters are exclusively provided for the operation with HVR supply modules. On the filter outlet side no other devices may be connected. If other components in the control cabinet are to be suppressed, it is necessary to employ an appropriate interference suppression (e.g. a line filter NFD02.x) which should preferably be installed at the control cabinet entry (see chapter 8.9 "Interference elimination"). It is not advisable to switch an additional interference suppression with the HZF in series, as non-linear procedures in the interference suppression filter (saturation of the chokes) could affect the combining filters' effect.

The combining filters are located in a(n) (attachable) housing suitable for the DIAX04 family. They must be mounted directly next to the supply module (on the right or left).

The supply line to the HZF must be shielded in order to avoid guided interference emissions.

The connection cables of the commutation choke have a connected voltage of high amplitude and frequency. This can result in a possible interference of sensitive units in the control cabinet. Therefore, the connection cables need to be kept as short as possible and absolutely twisted (here it would also be better to use shielded cables).

If a transformer is used, it is possible to connect HVR supply modules to networks with mains voltages smaller than 3 x AC 380 V or greater than 3 x AC 480 V.

Here, it is also required to use a commutation choke KDxx and a combining filter HZF01.1-W0xxN just as for the direct mains connection of the HVR supply modules.

Mains connection via transformer (with mains voltages < 3 x AC 380 V or > 3 x AC 480 V)

DC bus connection and bus connection

Note: The DC bus connection must **always** be connected to the HZF for proper functioning.

The X1 bus connection is looped through and must only be connected, if there are units arranged on both sides of the HZF.

Control voltage supply

A separate control voltage connection is necessary that the HVR may be operated synchronously to the mains. The control voltage must be tapped before the commutation choke KDxx. Power and control voltage connection must be in phase.

As illustrated in the next figure, the combining filter HZF is equipped with two control voltage outlets. The control voltage outlet X8 must be connected to the control voltage inlet of the HVR.

A protection switch for the control voltage is integrated in the HZF (F2).

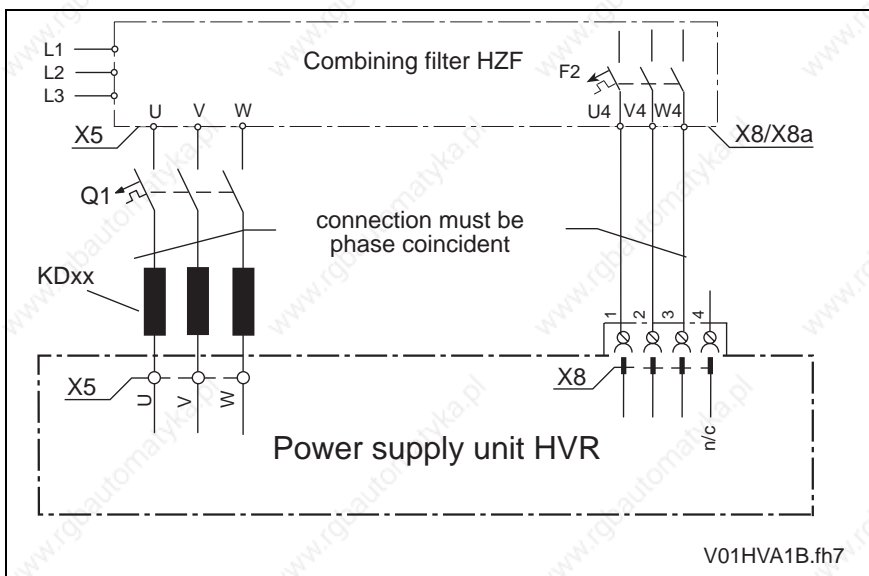

Fig. 8-11: HVR control voltage

Details of the commutation choke

The commutation chokes are equipped with a temperature contact which opens at $T = 150\text{ °C}$ (connections a - b). The contact can be evaluated by a controller and is used for example for a regulated shutdown of the unit, should the control cabinet cooling fail.

Note: You'll find the technical data in chapter 4.3 "Commutation choke KD". The dimension drawing as well as terminal diagram can be found on page 7-18.

Details of the combining filter

Note: You'll find the technical data in chapter 4.4 "Combining filter HZF".

8.4 Fusing with direct mains supply

Fusing the mains supply for the power section of the power supply units HVE and HVR can implement, with direct mains connection, power circuit breakers or slow-blow fuses of the gL type (semiconductor fuses are not needed).

Note: Select the fusing according to the mains current too (see 5.7 "Connected load of the power supply unit").

The maximum fusing for the different power supply units (HVR and HVE) is listed in the following table.

Power supply unit	Fuse maximum
HVE02.2-W018N	35 A
HVE03.2-W030N	63 A
HVE04.2-W075N	160 A
HVR02.2-W010N	25 A
HVR02.2-W025N	50 A
HVR03.2-W045N	80 A

Fig. 8-12: Maximum fusing

If the fusing is effected with power protective switches, the following recommendations apply.

Power supply unit	Mains current at		Power circuit breaker (Siemens)	Setting value	Mains connected load at 400 V connected voltage ¹⁾
	400 V	480 V			
HVE02.2-W018N (without GLD 13)	28 A	28 A	3VU1600-MQ00 ²⁾	28 A	6 mm ²
HVE02.2-W018N (with GLD 13)	28 A	28 A	3VU1600-MQ00 ²⁾	28 A	6 mm ²
HVE03.2-W030N (without GLD 12)	46 A	46 A	3VU1600-MR00	46 A	16 mm ²
HVE03.2-W030N (with GLD 12)	46 A	46 A	3VU1600-MR00	46 A	16 mm ²
HVE04.2-W075N (without GLD 20)	80 A	80 A	3VF3111-5DN71	80 A	25 mm ²
HVE04.2-W075N (with GLD 20)	120 A	120 A	3VF3111-5DS71	120 A	50 mm ²
HVR02.2-W010N	15 A	13 A	3VU1300-MM00 ³⁾	18 A	2,5 mm ²
HVR02.2-W025N	38 A	32 A	3VU1300-MQ00 ²⁾	38 A	10 mm ²
HVR03.2-W045N	68 A	57 A	3VF3111-5DN71	68 A	25 mm ²

1): Line cross section per EN 60204 – installation type B1 – without accounting for corrections factors

2): Max. back up fuse as manufacturer: 200 A (gL) with connected voltage up to 500 V

3): Max. back up fuse as manufacturer: 80 A (gL) with connected voltage up to 500 V

Fig. 8-13: Recommended fusing

Note: The indications made herein apply to the operation with full continuous power. If fewer continuous currents are required, the fusing and thus the connection cross section can be reduced. It should however be taken into account that the bus is loaded according to the soft start with each unit peak current (3-fold continuous power). The period of time during which the current flows, depends on the bus capacity to be loaded and is 33 ms in the most unfavorable case with the 45 kW unit, 57 ms with the 25 kW unit and 142 ms with the 10 kW unit. The fuses to be installed or the power protection switches shall be dimensioned such that faulty releases do not occur.

8.5 Grounding the power supply system

Grounded three-phase mains HVE and HVR can be operated from three-phase systems with grounded neutral points or phases without control-to-load isolation.

Ungrounded three-phase mains With ungrounded mains (IT mains) there is the increased danger that unacceptably high overvoltages could occur between the phase and the housing. Both the HVE and HVR can be protected against unacceptable overvoltages,

- if they are connected via an isolating transformer (the star point of the output side and the PE connection of the power supply unit are connected over one grounding rail)

- or -

- if the unit is protected by **over voltage suppressers**.

Note: Connecting the HVE and HVR via an isolating transformer offers the best protection against overvoltage and the greatest operating safety.

8.6 Connecting drive controllers to the power supply unit

Note: For the connection of the drive and control system to the power supply unit it is necessary to distinguish between the arrangement of the units one below the other and one above the other.

The following descriptions are visualized in "Fig. 8-16".

Arranging the units horizontally

Power connection If the units in the control cabinet are arranged horizontally, use the copper strands and PE bridges, included in the delivery scope, for the power connection of the drive and control systems.

Connection to the control voltage supply Use the flat cable for the connection to the control voltage bus (terminal X1). One side of the flat cable is firmly connected to the unit on one side. Plug the connector of the free end onto terminal X1 of the next unit.

If the units are not arranged directly horizontally, you will need a longer cable for the connection of the X1 terminals (cable designation: INB648).

The cable lengths listed below are available:

Cable length [mm]	Item / Material number
50	274 777
100	274 776
150	274 775
175	276 785
200	274 774
250	276 811

Fig. 8-14: Flat cable for the control voltage bus

Arranging the units vertically

Note: With a combined unit arrangement, it is absolutely necessary that between the two rows of drive units a baffle is mounted, in order to prevent the blowers of the upper row from sucking in the warm air of the bottom row.



CAUTION

Property damages due to overheated units!

⇒ Mount a baffle between the two unit rows. Otherwise the performance data of the units can decrease and the units can be damaged with undiminished performance requirement.

Mains connection

If the units in the control cabinet are arranged vertically, you need to use twisted single conductors for the power connection of the drive and control systems (terminal X1) instead of the supplied copper strands. The single conductors for the power connection of the drive and control systems may have a maximum length of 1 m.

The ground connections of units (unit rows) that are vertically arranged must be connected by a separate cord. The minimum cross section for this cord is 10 mm².

Connection to the control voltage bus

The control voltage bus must be connected with the designed Rexroth Indramat cable (designation: INB0647). Lay the shield of this cable to the unit grounding bolt (terminal X12) on the supply module.

The cable lengths listed below are available:

Cable length [m]	Item / Material number
0,8	282 300
1,0	287 677

Fig. 8-15: Flat cable for the control voltage bus

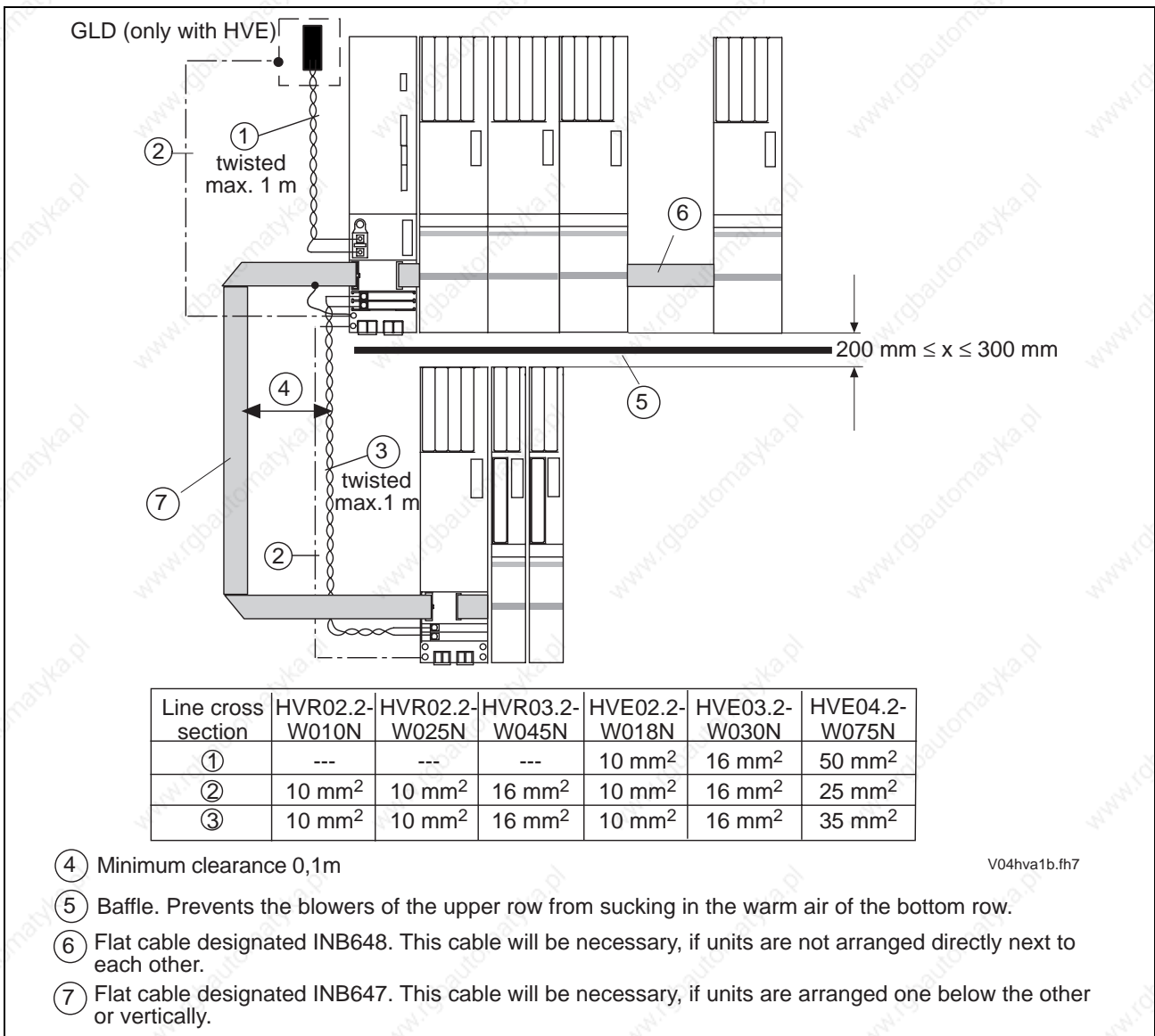

Fig. 8-16: Connecting the drive controller

8.7 Fault current protective device

Preferably, the overcurrent fuse (fuse, protective circuit breaker) of the installation should shutdown in the event of a casing short. If, for example, in **TT mains** a current fault protection device is urgently needed due to the excessive earth resistance, then the following should be noted.:

- In clocked drive controllers, capacitive leakage currents primarily flow to earth. The extent of this current depends on
 - the number of drive controllers used,
 - the length of the motor power cable and
 - the grounding conditions at the installation.
- If measures are taken to improve the electromagnetic compatibility (EMC) of the installation (mains filters, shielded lines, etc.), then the current leakage is inevitably also increased. In order to avoid faulty releases when inductive loads and capacitance (interference suppression filters, transformers, contactors, magnetic valves) are switched on, it is necessary to provide an isolating transformer in the mains supply line ahead of the power supply unit of the drive system. The over current protective device must be matched to the impedance of the fault loop so that a shutdown is effected if a fault occurs. The star point of the secondary winding must be connected to the protective circuit of the installation.

8.8 Earth leakage monitor

Earth leakage monitors are often used in IT mains. Spurious releases can occur when operating electronic equipment.

Experience has shown that electronic drive controllers can only be operated on systems with earth leakage monitors if an isolating transformer is situated ahead of the supply unit for the drive system. The star point of the isolating transformer and the PE connection of the power supply unit must be applied to the same potential.

8.9 Interference elimination

Note: The subject interference elimination and electromagnetic compatibility (EMC) is described in detail in a separate documentation. It is absolutely necessary to read this documentation for the proper operation of AC-drives!

The document is titled "Electromagnetic compatibility (EMC) for AC drives". The item number is 259 740.

Note: The control cabinet construction is also important for shielding the interference emission. For further information please see the chapter 7.3 "Optimal EMC installation".

Note: As the HVR power supply unit must be operated together with the combining filter HZF, the indications concerning the NFD mains filter arrangement apply above all to the HVE. (The line filter is already included in the combining filter HZF).

Interference emission

To maintain class B limit values (interference suppression N) as per EN 55011 / 3.91 at the machine (required in residential and light industrial areas), suitable interference suppression filters must be installed in the mains supply line in the machine. The motor power cable should be routed in a shielded manner or a shielded motor power cable should be used.

Resistance to interference

Rexroth Indramat drives are characterized by an extensive resistance to mains and circuit interference. Nonetheless, during installation the following should be noted to preclude interference affects.

- Always route signal lines shielded.
- With analog signals, connect the shield at one end, over the greatest possible surface on the unit to mass or housing. With digital signals, apply shield to both cable ends, over the greatest possible surface to mass or housing.
- Signal and control lines should be routed at least 10 cm away from the power cables. Routing in a separate cable duct is recommended.
- Signal and control lines should cross power cables at an angle of 90° only.
- Inductive loads such as contactors, relays, magnetic valves should only be operated with overvoltage limiters.
- Ground drive controllers as per Rexroth Indramat guidelines.

8.10 Control cabinet check



CAUTION

Property damages due to overloaded electronic components!

⇒ Prior to a high-voltage check of the control cabinet, disconnect all power supply unit connections. Only connect those voltages permitted by data sheets or interface descriptions.

9 Control mains contactor

9.1 Control possibilities

The controls of the mains contactor and of the DC bus dynamic brake in the power supply unit, that are suggested in this documentation, explain the function principles. In this chapter, several control options are discussed and explained.

Note: Which control and functions are selected ultimately depend on the extent of functions required and the range of actions of the entire installation and is primarily the responsibility of the manufacturer.

Shutdowns with faulty drive electronics

An additional safety for braked shutdowns of the drives in case of faulty drive electronics is to short-circuit the DC bus voltage.

If the DC bus voltage is short-circuited, the motors with permanent energized magnet will always be shut down to a braked condition. This is the case whether the drive electronics is operative or not.

Note: Asynchronous drives do not brake when DC bus voltage is short circuited!

If the drive electronics is interfered and the DC bus voltage is not short-circuited, then the motors with energized permanent magnet will slow down uncontrolled.

Braking with emergency stop or power failure

In an emergency stop or power failure situation, drives are generally shutdown by the drive control.

Given an emergency stop or with actuation of the drive-internal monitor, the drive control command value is set to go to zero and the drives brake controlled at maximum torque.

In some applications, however, e.g., electronically-coupled gear cutting machines, it is necessary to bring the drives, given an emergency stop or power failure, to a standstill controlled by the CNC. In an emergency stop situation or given the actuation of the drive-internal monitor, the drives are shutdown position-controlled by the NC control.

9.2 Controlling the power supply unit with emergency stop relays

With DC bus dynamic brake

If the mains contactor in the power supply unit is controlled via the emergency stop relay and the DC bus is short-circuited, you will reach maximum safety possible thus with very little expenditure. The drive system monitors are most effectively used. The drive system monitors are most effectively used.

- Applications** You should use this mode, if
- only motors with permanent magnetic excitation have been mounted,
 - or if motors with permanent magnetic excitation and asynchronous motors (induction machines) have been mounted,
 - or if the emergency stop circuit must be duplicated or if e.g. a protection door monitor is required,
 - or if your drive system includes an extended and substantial emergency stop chain.

Note: As the energizing current of the mains contactor flows via the emergency stop chain, the voltage drop must not become too great. To ensure a reliable energizing, the total resistance of the emergency stop chain which comes into effect between the connections X3/1 and X3/6 must be under 1.3Ω (HVE02.2, HVE03.2 and HVR) or $350 \text{ m}\Omega$ (HVE04.2)!

Features The DC bus dynamic brake can shutdown motors with permanent magnetic excitation even with a fault in the drive electronics. A prerequisite, however, is a pertinent programming of the drive controller (parameter "Shutting down power in the event of a fault"). The DC bus dynamic brake is only active in the event of drive errors. If the emergency stop is actuated, asynchronous drives will also brake.

In an emergency stop situation or with actuation of the monitor in the power supply unit (e.g., power failure), the drives are shutdown by the drive electronics in the manner set for the specific error reaction.



WARNING

Property damages due to uncontrolled axis movements!

The DC bus dynamic brake protects machines against drive errors. It alone cannot assume the function of protecting personnel. Given faults in the drive and power supply unit, uncontrolled drive movements are still possible even if the DC bus dynamic brake is activated ($X3/2 = 0$).

Asynchronous machines do not brake if the DC bus is short-circuited. Depending on the type of machine, injury to personnel is possible.

⇒ Additional monitoring and protective devices should be installed in the installation.

Function When actuating the emergency stop key, the mains contactor in the power supply unit immediately falls off. Drive enables are shut off by the emergency stop relay or an auxiliary contact of the mains contactor. The drives are shutdown as per the error reaction set in the drive controller.

A drive error message from the supply module (Bb1-contact), an error message by the NC control (servo error) or the overtravelling of the end limit switch causes the mains contactor to be switched off and the DC bus dynamic brake to be actuated.

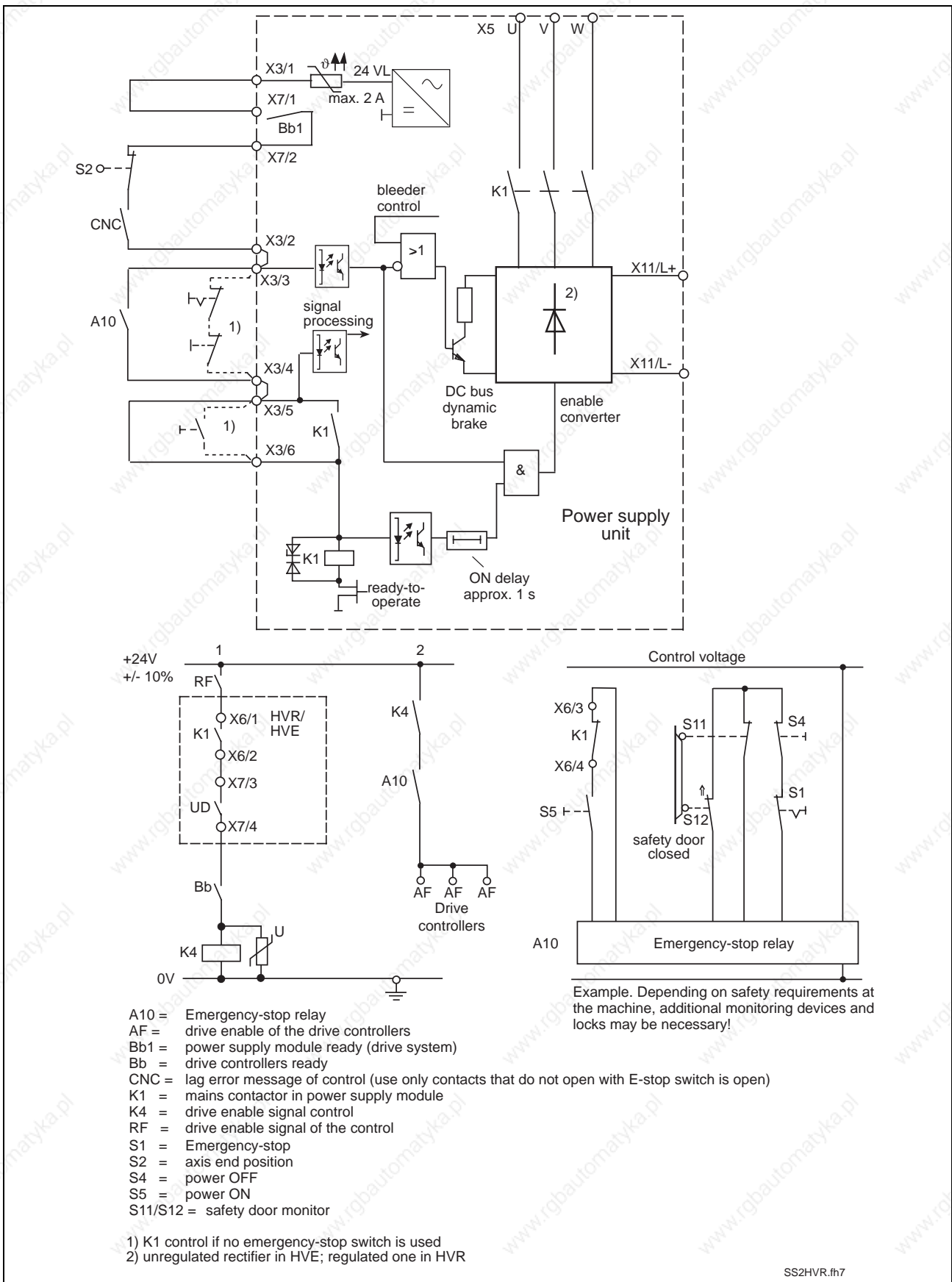

Fig. 9-1: Control of the power supply unit with DC bus dynamic brake in the event of faulty drive electronics

Without DC bus dynamic brake

- Application**
- If an uncontrolled running out of the drives cannot damage the installation.
 - If only asynchronous drives are connected to the power supply unit.
 - If the end positions of the feed axes are sufficiently attenuated.
- Features** The DC bus voltage is not short-circuited.
In an emergency stop situation, or if the monitors of the power supply unit are actuated (e.g., power failure), then the drives are shutdown by the drive electronics as per the set error reaction.
- Function** The mains contactor in the power supply unit immediately falls off when the emergency stop sequence is initiated. The drive enable is removed by the emergency stop relay or by an auxiliary contact of the mains contactor. The drives are shutdown depending on the set error reaction.



CAUTION

Machine damages due to brakeless slowing down of the drives in the event of faulty drive electronics!

- ⇒ Use motors with mechanical brakes (a holding brake must not be used as operating brake).
- ⇒ End positions of feed axes must be sufficiently attenuated.

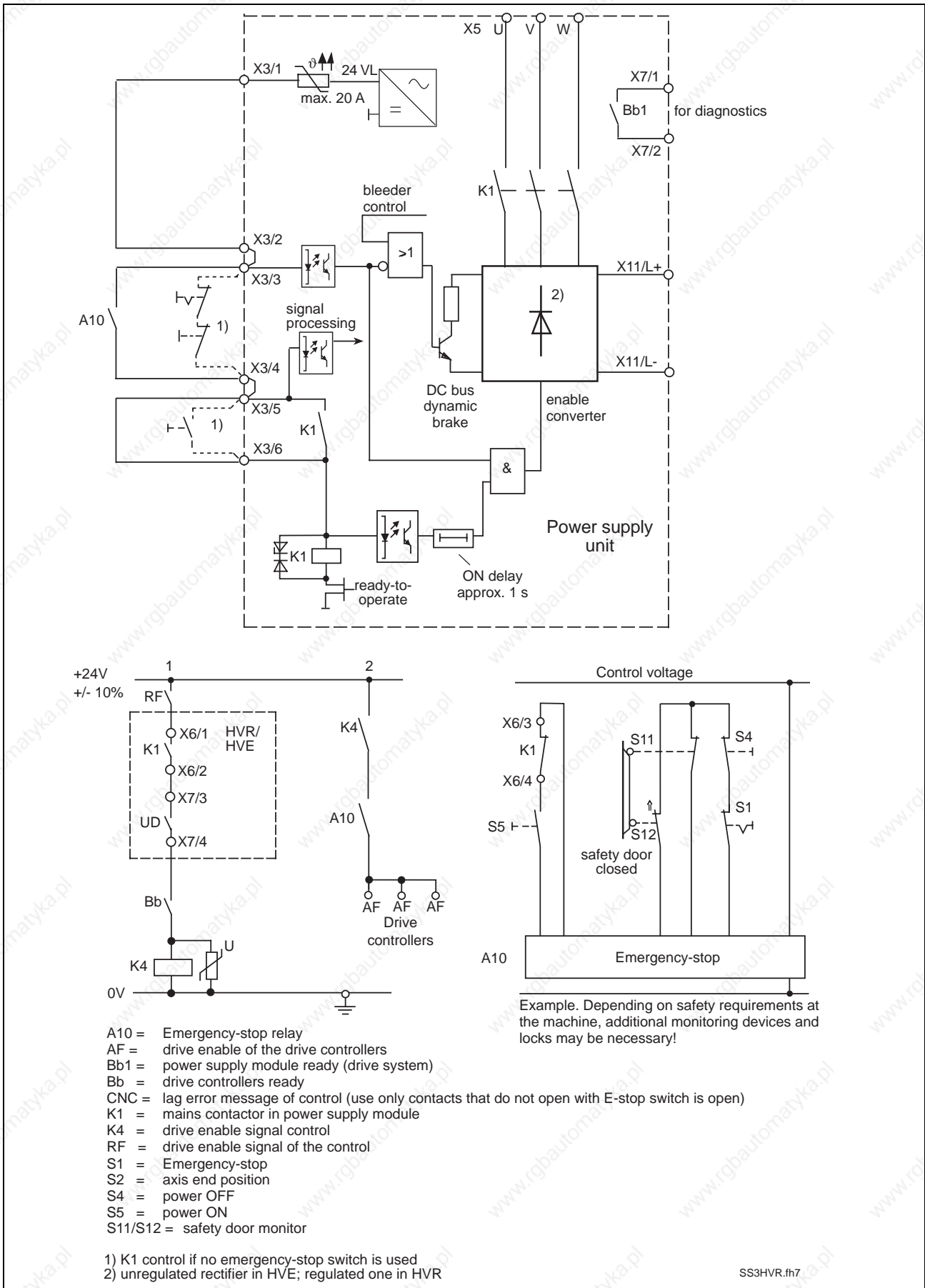

Fig. 9-2: Control of the power supply unit without DC bus dynamic brake

9.3 Control via NC controller

If the mains contactor is controlled via NC controller, it is possible to provide a position controlled shutdown of the drive via the NC controller in the event of an emergency stop or as reaction of the internal monitoring of the drive.

Application This kind of mains contactor control is mostly used with drives which are electronically coupled and shutdown synchronously when a power failure occurs.

Features The DC bus voltage is not short-circuited so that power for a position-controlled shutdown of the drives is available.

Note: The energy stored in the DC bus or the regenerated energy must be greater than the energy needed to excite asynchronous machines or for the return motion.

The parameter " Activating NC reactions with a fault" must be programmed in the drive controller (P-0-0117, bit 0 = 1).

Given an emergency stop or the actuation of the power supply unit monitor (e.g., power failure), the drives are shutdown position-controlled by the position controller.

Function Upon initiating the emergency stop sequence, or with the actuation of the monitor in the power supply unit (e.g., power failure), the mains contactor in the supply unit falls off.

Drives with SERCOS interface signal the error to the NC control, meaning that the drives can be shutdown position controlled.

Drives without SERCOS interface require the control to evaluate the UD contact. If the UD contact is actuated, then the NC control must shut down the drives.



CAUTION

Machine damages due to brakeless slowing down of the drives in case of too little DC bus voltage!

⇒ The controller should evaluate the UD contact and shut down the drives, when the contact reacts.

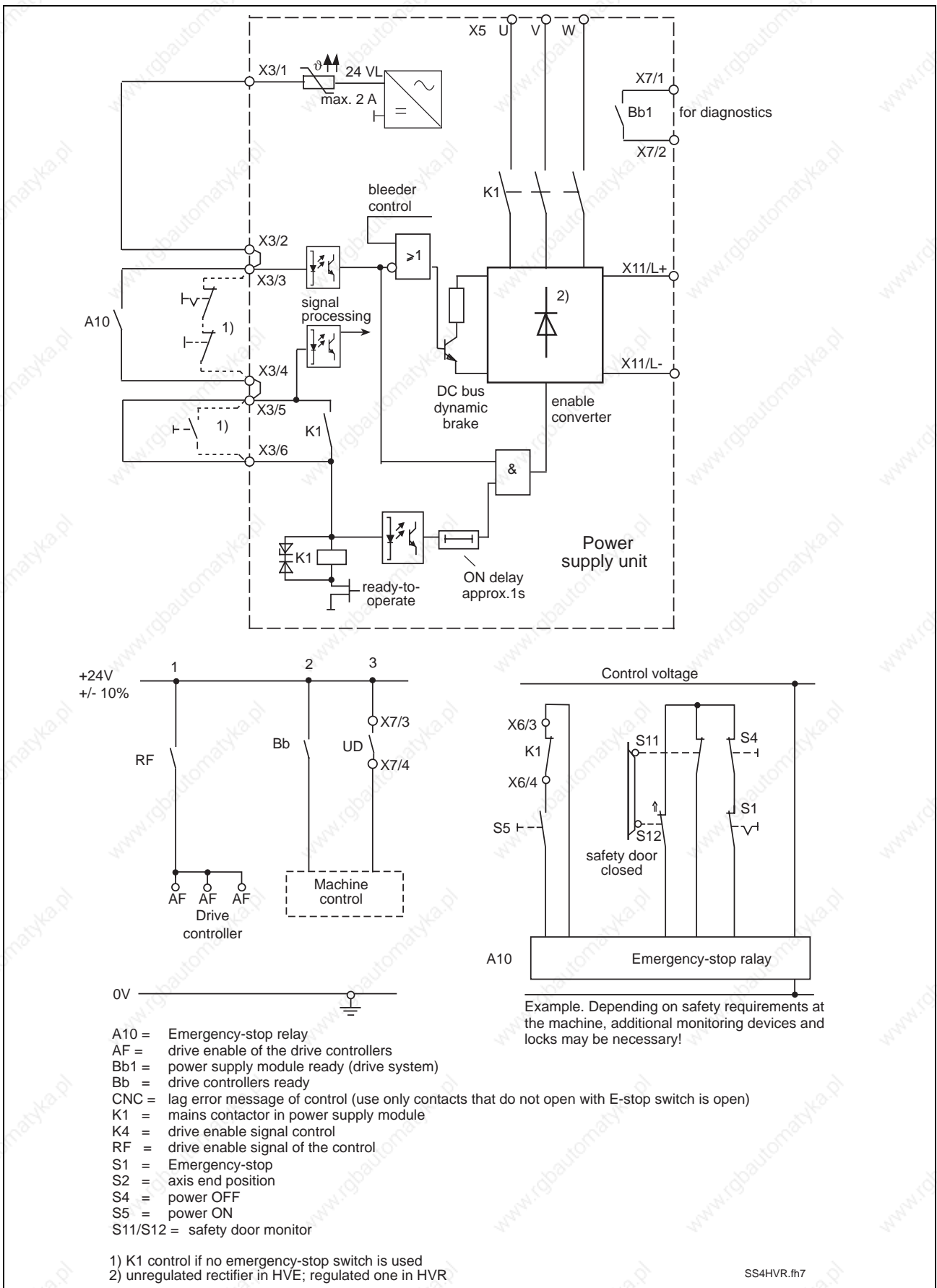

Fig. 9-3: Control for position controlled shutdown of the drives via NC-controller (without DC bus voltage brake)

Notes

10 Interfaces for system control

10.1 DC bus dynamic brake

The DC bus brake switching is activated via plug-in terminal X3 and the mains contactor in the power supply unit is switched:

Input "OFF" Only with closed input (Power) "OFF" can the power contactor in the power supply unit be switched on. If input OFF is open, then the power contactor in the power supply unit is immediately switched off.

Input "ON" If the inputs "ZKS" and "OFF" are closed and the unit is internally ready for operation, then the power contactor in the power supply unit is switched on while the input "ON" is closed.

The ON impulse must be applied for at least 200 ms.

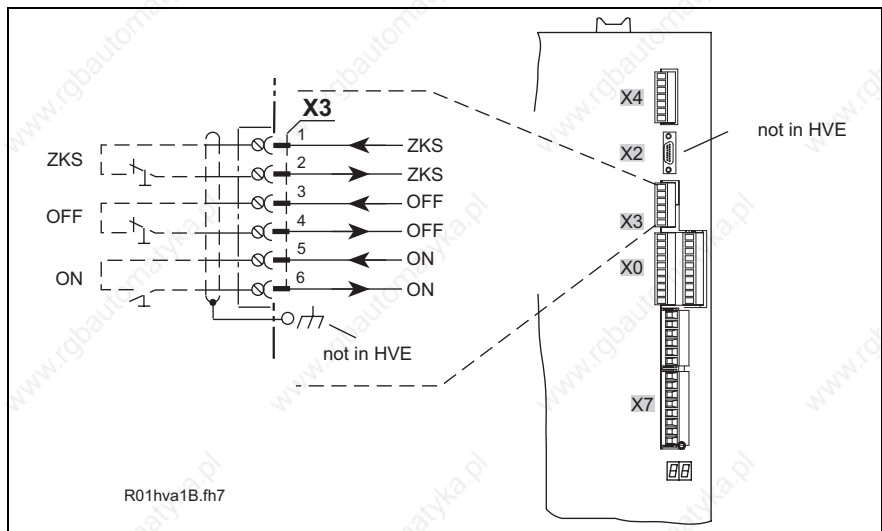

Fig. 10-1: Terminal assignment X3

Power supply unit	Voltage (DC) [V]	Break-away starting current [A]	Holding current [A]
HVE02 / 03	24	8	0,45
HVE04	24	20	0,45
HVR	24	8	1

Fig. 10-2: Technical data of the DC bus

As an additional installation protection in the event of drive electronic problems, the DC bus is short-circuited with an open DC bus input. Motors with permanent magnet excitation can, in this case, still be shutdown in a controlled manner.



Injury to the personnel due to uncontrolled drive movements!

⇒ In the event of faults in the drive and supply unit, uncontrolled drive motions are still possible even if the DC bus circuit is activated. Therefore provide additional monitoring and protective equipment to the system.

Note: As the energizing current of the mains contactor flows via the emergency stop chain, the voltage drop must not become too great. To ensure a reliable energizing, the total resistance of the emergency stop chain, which comes into effect between the connections X3/1 and X3/6 must be under 1.3 Ω (HVE02.2, HVE03.2, and HVR) or 350 mΩ (HVE04.2)!

Number of switching actuations

The power of the DC bus brake resistor is needed for the calculation of the permissible number of switching actuations:

HVE02	HVE03	HVE04	HVR02 and HVR03
1000 W	1500 W	2500 W	400 W

Fig. 10-3: Power of the DC bus brake resistor (P_{ZKS})

$$z = \frac{2 * P_{ZKS}}{2C_{ZU} * U_B^2 + J_g * \omega^2} * 60$$

U_B : bleeder actuating threshold [V] (820 V)

C_{ZU} : DC bus capacitance [F]

J_g : total moment of inertia [kgm²]

P_{ZKS} : power of the DC bus brake resistor

ω : angular speed [rad/s]

z : number of switching actuations per minute

Fig. 10-4: Number of switching actuations with aux. capacitance and rotating motor

Note: A maximum number of 16 switching actuations per minute applies to the mains contactor K1.

The number of switching actuations (service life of the contact elements) is 1 million for HVR and HVE units, however only if the contactor is switched current less. If switched in loaded condition (e.g. when emergency stop is released), the number of switching actuations for both unit families is 400 thousand.

10.2 Control voltages

Control voltages 24 VL and ± 15 VM can be tapped off of terminal strips X4/1 ... X4/6. These terminals are intended for measuring and test purposes.

If these voltages are used outside of the drive system, then make sure that no interference voltages are coupled in (short, shielded lines). The load carrying ability of the control voltages is correspondingly reduced by the drive controllers.

The control voltage outputs are short-circuit proof. The maximum permissible load must not be exceeded in order not to endanger the functions of the drives.

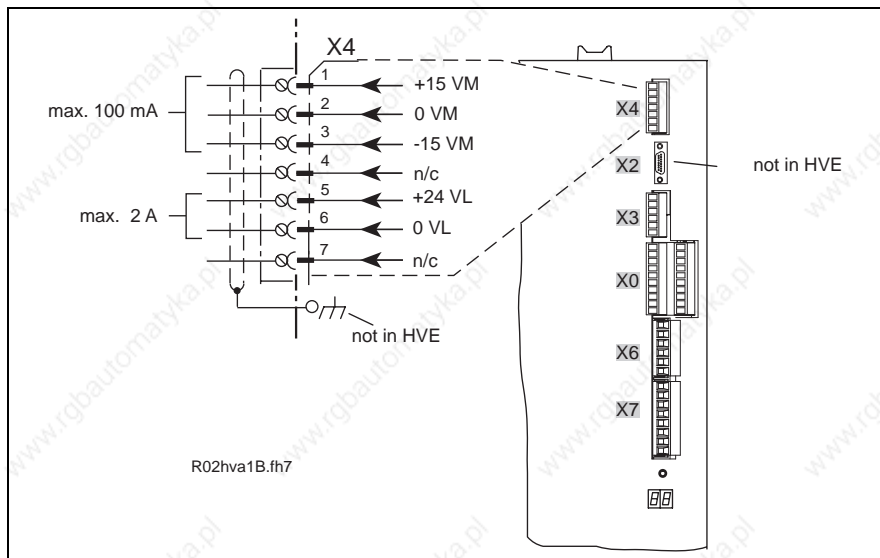

Fig. 10-5: Terminal assignment X4

10.3 Controlling auxiliary components

Auxiliary components, e.g., HZF, can be mounted to either side of the power supply unit. Ensure that the contacts X0.1 ... X0.10 are connected in parallel from the power supply module through to the additional component. The bridges X0.1 to X0.5 and X0.6 to X0.10 must be mounted to connector X0 on the last auxiliary module. The bridges at delivery are in the connector on the power supply module.

As the drive and control systems do not show these connections, it is necessary to lead the parallel connections passing the drive and control systems to the additional component depending on the order of the mounted devices.

10.4 Acknowledging the power supply unit mains contactor

The acknowledge outputs are on terminal X6.

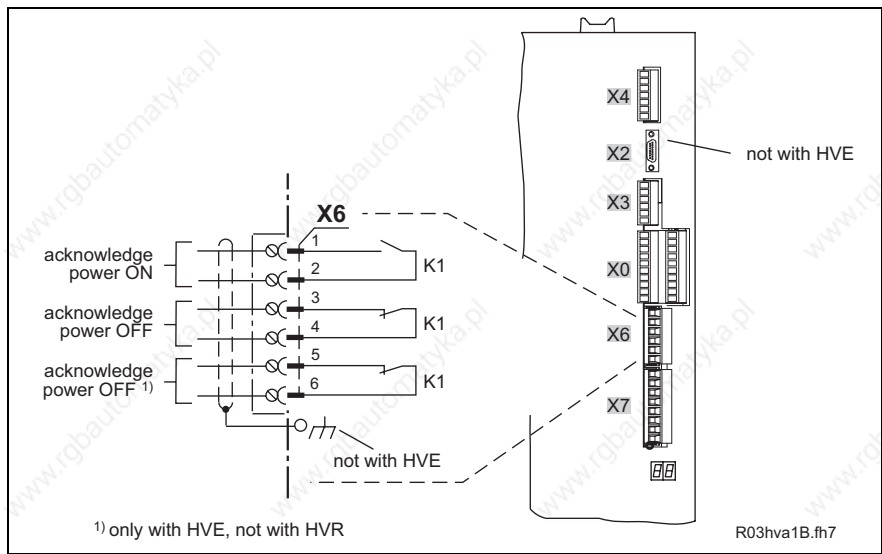

Fig. 10-6: Terminal assignment X6

Continuous current	Starting current
DC 24 V/1 A	DC 24 V/1 A
AC 220 V/1 A	AC 220 V/1 A

Fig. 10-7: Maximum contact load



Electrical shock upon contact!

⇒ Assign the contacts of the terminals X6 and/or X7 to the same voltage potentials, as there is the danger of voltage transmission, when voltage potentials are not the same.

"Acknowledge power ON"

At output acknowledge power ON it can be queried as to whether the mains contactor in the supply unit is on or not. The contact is closed if the mains contactor is on. It can be used as a precondition for the drive enable signal.

"Acknowledge power OFF"

At output acknowledge power OFF it can be queried as to whether the mains contactor in the supply unit has dropped off or not. If it has, then the contact is closed. This can be used as a precondition to enable the safety door lock.

There is restricted guidance between the acknowledge power OFF contact and the main contacts of the mains contactor in the power supply unit.

On the HVE power supply unit, there are two brake contacts labeled as "Acknowledge power Off" led to the outside of the unit.

10.5 Ready-to-operate and other messages

The terminal X7 contains outputs

- signaling that the drive systems are ready for operation,
- acknowledging the proper power supply,
- warning that the device is overheated, and
- warning that the regenerated power is too great.

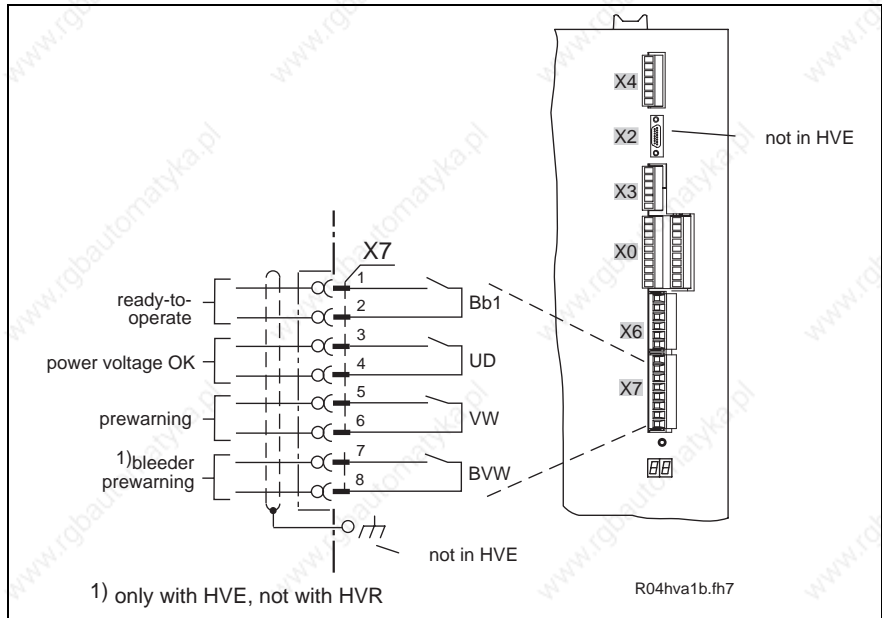

Fig. 10-8: Terminal assignment X7

	HVE		HVR
Continuous current	DC 24 V/1 A	AC 250 V/1 A	DC 24 V/1 A
Starting current	DC 24 V/1 A	AC 250 V/1 A	DC 24 V/1 A

Fig. 10-9: Maximum contact load



Electrical shock upon contact!

⇒ Assign the contacts of the terminals X6 and/or X7 to the same voltage potentials, as there is the danger of voltage transmission, when voltage potentials are not the same.

Ready-to-operate (Bb1)

The Bb1 contact of the power supply unit is of higher-ranking significance. It signals that the drive is ready to receive power. Only if closed, the locks within the unit allow switching the mains contactor to the power supply unit.

In the event of a fault, the power contactor is shut off and the Bb1 contact opens. If this contact opens, then there will probably not be a controlled shutdown of the drives. It can, therefore, be used as a precondition for letting the DC bus dynamic brake drop in.

The Bb1 contact opens with the following faults:

- faults in the power supply unit and
- faults in the drive controller (power off must be parametrized in the drive controller).
- faults in auxiliary components.

The Bb1 contact closes if the control voltage at terminal X8 is applied and no error is pending.

Power supply in order (UD)

The UD contact acknowledges that the power supply is in working order.

It opens in the event of the following faults:

- mains fault,
- DC bus voltage is smaller than the permissible minimum value (HVR: 680 V, HVE: 80% of \dot{U}_{Netz}) and
- when switching off K1.

If the installation requires that the drives be shutdown with position control in the event of a mains fault, then the installation control must evaluate the UD contact and shut down the drives in a controlled fashion.

Pre-warning (VW)

The pre-warning contact is opened, if the cooling unit temperature in the power supply unit is too high or a critical value is reached in an auxiliary component. The mains contactor in the power supply unit interrupts the power supply after 30 seconds and the Bb1 contact opens.

Note: If the installation requires that the drives are shut down in a position controlled fashion if there is a fault in the unit, then the drives must be shutdown within 30 seconds.

Bleeder pre-warning contact (BVW)

The bleeder pre-warning contact only exists in the HVE power supply units. The bleeder pre-warning contact opens if continuous regenerated power exceeds 80% of the continuous bleeder power. If the bleeder power continues to rise, then the mains contactor stops the HVE power supply unit and the Bb1 contact opens.

Chronological sequence when switching on and off

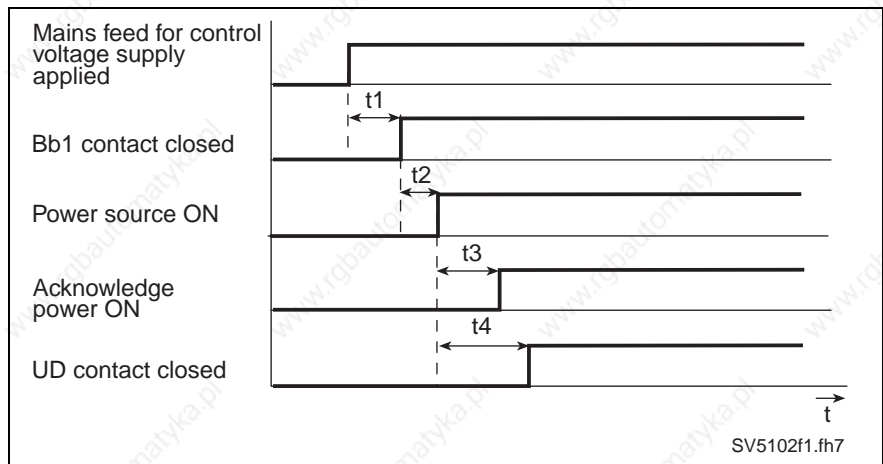

- t1: Depends on parametrized function of the drives
- t2: Depends on the reaction time of the PLC
- t3: On-delay of the K1 mains contactor in the unit (maximum 100 ms)
- t4: Time to build up DC bus voltage [maximum 4,1 s, value applies to maximum additional capacitance (10 mF or 20 mF)!]

Fig. 10-10: Chronological sequence when powering unit up

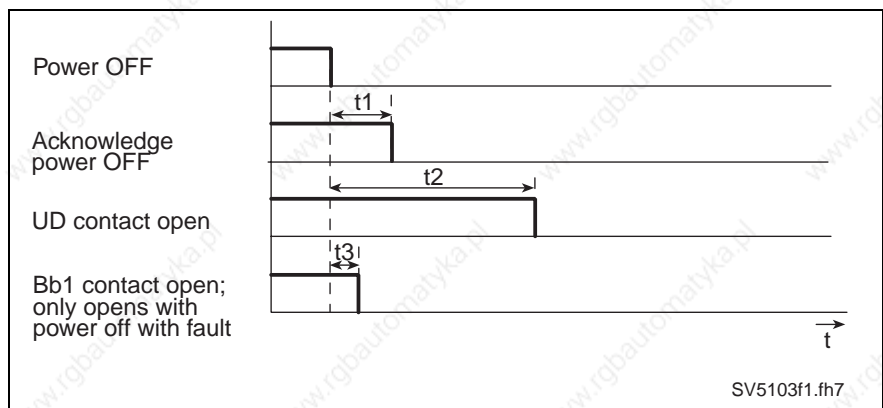

- t1: On-delay of the K1 mains contactor in the unit (maximum 100 ms)
- t2: Depends on reduction of DC bus voltage (maximum 500 ms)
- t3: Only opens with power shutdown due to a fault (fault in supply unit, drive controller or due to mains failure) (maximum 25 ms)

Fig. 10-11: Chronological sequence when shutting down the unit

Notes

11 Troubleshooting

11.1 General

Extensive searches for faults and repair of drive components on the machine are not acceptable due to the production downtime involved.

The modular concept of Rexroth Indramat AC drives makes it possible to completely exchange drive components. Service thus means localizing problems either on the motor, drive controller or power supply unit and replacing the part. No further adjustments are needed.

11.2 Fault diagnostics and resetting faults

Fault diagnostics The power supply unit signals operating states, warnings or faults via a two-place 7-segment display.

A prerequisite for fault diagnoses is a control voltage of +24 V, ± 15 V and +5 V and processors in the supply and drive controllers that are working properly.

Resetting faults Stored fault messages must be reset before the unit will again operate. An error can be reset by

- pressing the RESET key on the unit,
- switching the control voltage off or
- generating the reset command of the control via the control voltage bus.



CAUTION

Destruction of the power supply module, if the power is switched on to a faulty drive controller!

⇒ Upon RESET of an over current fault and after replacement of a defective supply module, the fault memories of the drive controllers must be read out prior to switching it on.

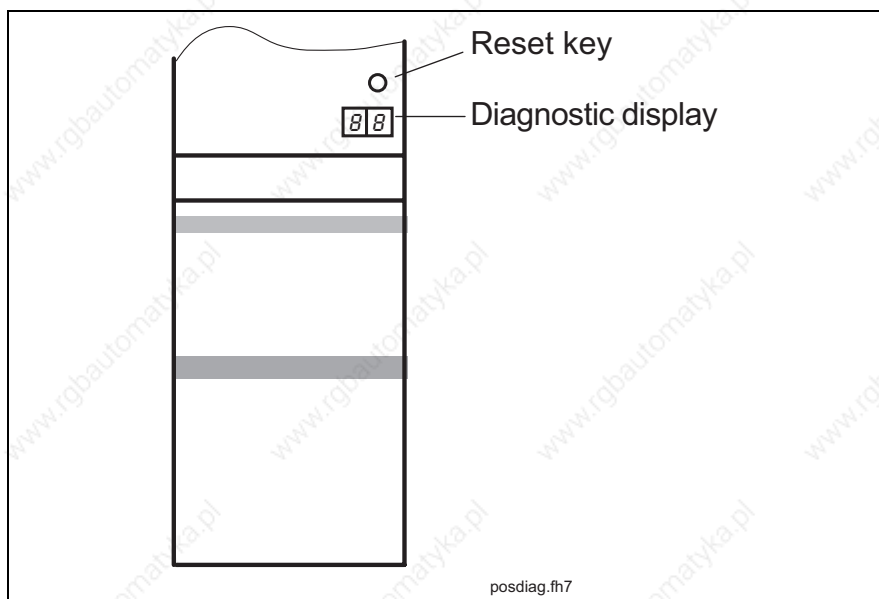

Fig. 11-1: Position of diagnostic display and reset key

If either checks or repairs are needed, then it applies:

- Checks and repairs may only be conducted by Rexroth Indramat customer service personnel or such personnel that has been trained to do so.
- Observe the applicable safety regulations when checking the unit.
- Repairing drive components on the machine is very time consuming. Replace defective drive components completely.



WARNING

When faults are cleared, damages to the machine and injury to the personnel may occur!

- ⇒ Fault clearance should only be conducted by trained personnel.
- ⇒ Protective devices must not be switched off.
- ⇒ Note the warnings in section 3.

11.3 Checking and repairing the unit

When contacting our service personnel we would like to ask you to provide the following information so that a quick and precise assistance can be assured:

- type designations and serial numbers of units and motors,
- the status of the fault,
- any diagnostic displays and
- software status, if necessary.

You'll find the telephone number of our service hotline in the chapter "Service & Support".

11.4 Replacing the unit

Note: Replacing the unit requires, depending upon unit weight, a lifting device and an identical replacement unit.



DANGER

Electrical shock due to voltage-containing parts of more than 50 V!

⇒ The unit may only be replaced by qualified personnel, which have been trained to perform the work on or with electrical devices.

Note: Prior to the replacement of the unit please check according to the type plates, whether these units are of the same types. Replace only units of the same types.

Proceed as follows:

1. Switch voltage to installation off and secure it against being switched back on.
2. Using an appropriate measuring device, check whether the installation is power free. Wait the discharge time.
3. Motors must be standing still.
4. Secure vertical axes against motion.
5. Release all connections from the defective unit.
6. Release the fixing bolts and remove the unit from the control cabinet. Use the lifting device, if necessary.
7. Hang replacement unit into mounting rails. Use the lifting device, if necessary.
8. Reconnect the unit as per the terminal diagram of the machine manufacturer.
9. If vertical axes have been mechanically secured prior to replacement, then remove these devices at this point.
10. While reading out the fault memories of the connected drive controllers make sure that the device fault has not been triggered by the drive controllers (see warnings in chapter 11.2 "Fault diagnostics and resetting faults").

The unit replacement is completed. The system can be put back into operation.

11.5 Diagnostic Display

Overview

Anzeige DISPLAY	Bedeutung ACCEPTATION	Erläuterung EXPLANATION
bb	- Bereit zur Leistungszuschaltung - - READY FOR POWER ON -	Supply and drives are fault-free. Power can be switched on.
Lb	- Leistung bereit - - POWER OK -	Mains contactor is ON. DC bus voltage within permissible range.
14	- Zusatzkomponenten Vorwarnung - - EXTERNAL COMPONENT WARNING -	WARNING an auxiliary unit is being applied. Power off in 30 s.
15	- Steuerspg.-Vers.-Temp.-Vorwarnung - ¹⁾ - CONTROL VOLTAGE TEMP. WARNING -	Control voltage supply is overloaded. The temperature pre-warning contact has opened.
16	- Softstartfehler - - SOFTSTART-FAULT -	DC bus cannot be loaded.
17	- Leistung Aus / Zwischenkreiskurzschluss - - POWER OFF WITH BUS SHORTING -	Power is off and DC bus dynamic brake activated.
18	- Kühlkörpertemperatur zu hoch - - HEATSINK OVERTEMP. FAULT -	Power off due to excessive heatsink temperature.
20	- Bleeder Überlast - - BLEEDER OVERLOAD -	Rotary drive energy (HVR/HVE) or regenerated power (HVE) too high.
23	- Antriebsfehler - - DRIVE FAULT -	Power off due to drive error.
24	- Zusatzkomponenten-Fehler - - EXTERNAL COMPONENT ERROR -	Power off due to fault in auxiliary unit (bleeder, loading device).
25	- Rückspeise-Überlast - - REGEN. POWER OVERLOAD -	Continuous regenerated power of the drives excessive.
26	- Einspeise-Überlast - - BUS POWER OVERLOAD -	The continuous feed in power of the drive excessive.
50	- Kühlkörper-Übertemperatur-Warnung - - HEATSINK TEMP. WARNING -	Temperature pre-warning contact is open. Power off in 30 s
52	Bleeder Überlast-Warnung - BLEEDER OVERLOAD WARNING -	80 % of the allowable bleeder ON time has been achieved due to excessive regenerated power.
60	- Überstrom - ¹⁾ - OVERCURRENT -	Short-circuit in supply or drive in motor or in a cable.
69	- +24 V / ±15 V / +5 V Fehler - - +24 V / ±15 V / +5 V FAULT -	Control voltages faulty.
80	- Erdschluss - - SHORT TO GROUND -	Ground fault in supply or drive unit, in motor or in cable.
81	- Netzausfall - ¹⁾ - POWER FAILURE -	One or several mains phases missing.
82	- Phasenfehler - ²⁾ - PHASELOSS FAULT -	One or several mains phases missing or the mains voltage is too low.
83	- Netzspannungsfehler - - LINE VOLTAGE FAULT -	Mains voltage exceeds permissible tolerance.
84	- Anschlussfehler - ¹⁾ - MISWIRING -	No phase coincidence in power and control voltage connections.
85	- Netzfrequenzfehler - ¹⁾ - LINE FREQUENCY FAULT -	Mains frequency exceeds permissible tolerance.
87	- Steuerspannungsversorgungs-Fehler - ²⁾ - CONTROL VOLTAGE SUPPLY FAILURE -	The HVE control voltage supply exceeds permissible tolerance.
94	- EPROM-Fehler - ¹⁾ - CHECKSUM ERROR -	Hardware or software error in unit.
..	- Gerätefehler - - DEVICE FAILURE -	Hardware or software error in unit.
--	- +5 V Fehler ²⁾ - +5 V FAILURE -	+5 V control voltage failure.

1): with HVR only

2): with HVE only

Fig. 11-2: Diagnostic display overview

Description, possible cause and troubleshooting

Display	Description	Possible cause	Troubleshooting
bb	Ready to receive power Supply unit and drive controller are ready.	<ol style="list-style-type: none"> 1) Power contactor has dropped off because OFF or emergency stop key was actuated. 2) The power contactor can not be activated, as its drive is faulty (if in principle, the power cannot be switched on). 	<ol style="list-style-type: none"> 1) Release button and switch power contactor on. 2) Check control - at X3/6 for at least 200 ms +24 V must be applied.
Lb	Power ready DC bus voltage within permissible range. The power supply unit is ready to supply power.		
14	Auxiliary component pre-warning A warning signal of an auxiliary unit is pending. Power is shutdown after 30 s.	<ol style="list-style-type: none"> 1) Temperature may be too high. 2) The end contactor has not been plugged to terminal X0. 	<ol style="list-style-type: none"> 1) Check auxiliary units. 2) Plug an end contactor to terminal X0 on auxiliary units.
15	Control voltage supply temperature pre-warning ¹⁾ The control voltage supply is overloaded. A power shutdown is pending.	There may be too many drives connected.	Check the dimensioning of the power supply unit.
16	Softstart error	<p>The DC bus cannot be loaded because</p> <ol style="list-style-type: none"> 1) there is a short-circuit in the power supply unit or in the drive controller. 2) too many additional capacitances have been connected. 3) the DC bus choke is cutoff²⁾ 4) the main contactor can not be activated²⁾ 	<ol style="list-style-type: none"> 1) Release connections to drive controller and switch power on again. Replace unit, if necessary. 2) Reduce the number of aux. capacitors or use a separate loading unit. 3) DC bus choke and lines must be check, replaced if necessary. 4) a) the permissible number of switching actuations has been exceeded. b) the maximum permissible resistance in the emergency stop chain has been exceeded.
17	Power OFF with DC bus dynamic brake The power contactor has dropped off. The DC bus dynamic brake was activated.	The control of the installation has triggered a DC bus dynamic braking action.	Check the emergency stop sequence of the installation.
18	Heatsink temperature too high Power shutdown.	Power shutdown due to excessive heatsink temperature because the unit is overloaded or the ambient temperature is too high.	<p>Load and ambient temperature must be checked.</p> <p>Evaluate prewarn contact of unit.</p>

Display	Description	Possible cause	Troubleshooting
20	Bleeder overload Power shutdown.	The power has been switched off due to excessive bleeder load because <ol style="list-style-type: none"> 1) the regenerated power on the HVR is too high with switched off power. 2) in the HVE, the continuous regenerated power and/or rotary drive energy is too high 3) the unit is defective. 	<ol style="list-style-type: none"> 1) Reduce drive speed. Switch power OFF or emergency stop in a delayed fashion. 2) Increase cycle time, reduce drive speed or install auxiliary bleeder. 3) Replace unit.
23	Drive error ³⁾	A drive controller has detected a fault in the unit, motor or line connections.	Diagnostic displays of drive controllers must be checked.
24	Auxiliary component error	<ol style="list-style-type: none"> 1) An error was detected in an auxiliary component, such as auxiliary bleeder, control voltage power section or separate loading device. 2) Bridges not inserted into connector X0. 	<ol style="list-style-type: none"> 1) Auxiliary components must be checked. 2) Bridges must be checked.
25	Regenerated overload ³⁾	The regenerated power of the drive is excessive.	Reduce permissible delay. Use drive controller with smaller peak current.
26	Feedin overload ³⁾	The feedin power required by drive is excessive.	Reduce permissible acceleration. Use drive controllers with smaller peak current.
50	Heatsink overtemperature-pre-warning The permissible heatsink temperature has been reached. The temperature pre-warning contact has opened. Power off in 30 s.	<ol style="list-style-type: none"> 1) Excessive load 2) Ambient temperature too high 3) Cooling air flow blocked 4) Blower in the unit defective 	<ol style="list-style-type: none"> 1) Reduce load 2) Reduce control cabinet temperature 3) Unblock cooling air flow 4) Replace unit
52	Bleeder overload warning	80 % of the allowable bleeder ON time has been achieved due to excessive regenerated power.	Reduce the allowable acceleration (delay). - or - Reduce drive speed - or - Reduce the peak current of the drive

Display	Description	Possible cause	Troubleshooting
80	Overcurrent ¹⁾	<ol style="list-style-type: none"> 1) Short circuit in supply unit, drive controller, motor or cable. 2) Too high continuous power. 	<ol style="list-style-type: none"> 1) Release power connections to the drive controllers step by step. Replace defective unit. 2) Check machine cycle; check drive design
89	+24 V / ±15 V / +5 V Fault	<p>The control voltages are faulty because:</p> <ol style="list-style-type: none"> 1) the maximum permissible load has been exceeded. 2) there is a short-circuit in the wiring of the control voltage used outside the drive systems. 3) the unit is defective. 	<ol style="list-style-type: none"> 1) Release bus connections to drive controllers step by step. 2) Release control voltage taps and check for short circuit. 3) Replace unit.
80	Ground fault	Ground fault in power supply unit, drive controller, motor or cable.	Release power connections to the drive controllers step by step. Replace defective unit.
81	Power failure ¹⁾	At least one phase of the mains supply is missing.	Check mains fuses and replace, if necessary.
82	Phase Fault	<ol style="list-style-type: none"> 1) At least one phase is missing of the mains supply. 2) The mains voltage is too low. 	<ol style="list-style-type: none"> 1) Check mains fuse and replace, if necessary. 2) Measure the mains voltage and compare it with the required data.
83	Mains voltage fault	<p>HVR: Mains voltage exceeds permissible tolerance (3 x 380 ... 480 V (± 10 %)).</p> <p>HVE: The maximum value of the mains voltage has been exceeded.</p>	Check mains voltage, use matching transformer if necessary.
84	Connection fault ¹⁾	Power and control voltage connections not phase coincident.	Check connection voltage. Terminals X5/U and X8/1, X5/V and X8/2, X5/W and X8/3 may not conduct voltage to each other.
85	Mains frequency fault ¹⁾	Mains frequency exceeds permissible tolerance (±2 Hz).	
87	Control voltage fault ²⁾	The control voltage supply exceeds permissible tolerance (3 x 380 ... 480 V (± 10 %)).	Check mains fuse in control cabinet and replace, if necessary.

Display	Description	Possible cause	Troubleshooting
94	EPROM fault ¹⁾	Unit fault.	Replace unit.
..	Unit fault	Hardware or software error in unit. HVR: Processor error HVE: Circuit error	Switch control voltage off and on. If error still present, replace unit.
--	+5 V error ²⁾	The +5 V control voltage is faulty because of a unit fault.	Replace unit.

1): Error message exists only with HVR units

2): Error message exists only with HVE units

3): Error is not saved

Fig. 11-3: Diagnostic display; acceptance, possible cause and recovery

12 Service & Support

12.1 Helpdesk

Unser Kundendienst-Helpdesk im Hauptwerk Lohr am Main steht Ihnen mit Rat und Tat zur Seite. Sie erreichen uns

- telefonisch: **+49 (0) 9352 40 50 60**
über Service-Call Entry Center Mo-Fr 07:00-18:00
- per Fax: **+49 (0) 9352 40 49 41**
- per e-Mail: **service@indramat.de**

Our service helpdesk in the head factory Lohr am Main is assisting you in all kind of queries. Contact us

- by phone: **+49 (0) 9352 40 50 60**
via Service-Call Entry Center Mo-Fr 07:00-18:00
- by fax: **+49 (0) 9352 40 49 41**
- by e-mail: **service@indramat.de**

12.2 Service-Hotline

Außerhalb der Helpdesk-Zeiten ist der Service direkt ansprechbar unter

oder **+49 (0) 171 333 88 26**
+49 (0) 172 660 04 06

Outside helpdesk hours, contact our service directly under

or **+49 (0) 171 333 88 26**
+49 (0) 172 660 04 06

12.3 Internet – World Wide Web

Weitere Hinweise zu Service, Reparatur und Training finden Sie im Internet unter

www.indramat.de

Außerhalb Deutschlands nehmen Sie bitte zuerst Kontakt mit Ihrem lokalen Ansprechpartner auf. Die Adressen sind im Anhang aufgeführt.

Further hints about service, repairs and training are available in the world wide web under

www.indramat.de

Please don't hesitate to contact first the sales & service agencies in your area. Refer to the addresses on the following pages.

12.4 Vor der Kontaktaufnahme ... - Before contacting us ...

Wir können Ihnen schnell und effizient helfen wenn Sie folgende Informationen bereithalten:

1. detaillierte Beschreibung der Störung und der Umstände.
2. Angaben auf dem Typenschild der betreffenden Produkte, insbesondere Typenschlüssel und Seriennummern.
3. Telefon-/Faxnummern und e-Mail-Adresse, unter denen Sie für Rückfragen zu erreichen sind.

For quick and efficient help, please prepare following information:

1. most detailed description of the failure and conditions.
2. Indications on the type plate of the concerned products, especially type codes and serial numbers.
3. Phone-/fax numbers and e-mail address by which we can attend you in case of queries.

12.5 Kundenbetreuungsstellen - Sales & Service Facilities

Verkaufsniederlassungen
 Niederlassungen mit Kundendienst

sales agencies
 agencies providing service

Deutschland – Germany

vom Ausland: (0) nach Landeskenziffer weglassen!!
from abroad: don't dial (0) after country code!

Vertriebsgebiet Mitte Germany Centre Rexroth Indramat GmbH Bgm.-Dr.-Nebel-Str. 2 97816 Lohr am Main Kompetenz-Zentrum Europa Telefon: +49 (0)9352 40-0 Telefax: +49 (0)9352 40-4885	SERVICE CALL ENTRY CENTER MO – FR von 07:00 - 18:00 Uhr from 7 am – 6 pm Tel. +49 (0) 9352 40 50 60 service@indramat.de	SERVICE HOTLINE MO – FR von 17:00 - 07:00 Uhr from 5 pm - 7 am + SA / SO Tel.: +49 (0)172 660 04 06 oder / or Tel.: +49 (0)171 333 88 26	SERVICE ERSATZTEILE / SPARES verlängerte Ansprechzeit - extended office time - ♦ nur an Werktagen - only on working days - ♦ von 07:00 - 18:00 Uhr - from 7 am - 6 pm - Tel. +49 (0) 9352 40 42 22
Vertriebsgebiet Süd Germany South Rexroth Indramat GmbH Ridlerstraße 75 80339 München Telefon: +49 (0)89 540138-30 Telefax: +49 (0)89 540138-10 indramat.mue@t-online.de	Gebiet Südwest Germany South-West Mannesmann Rexroth AG Vertrieb Deutschland – VD-BI Geschäftsbereich Rexroth Indramat Regionalzentrum Südwest Ringstrasse 70 / Postfach 1144 70736 Fellbach / 70701 Fellbach Tel.: +49 (0)711 57 61-100 Fax: +49 (0)711 57 61-125	Vertriebsgebiet Ost Germany East Rexroth Indramat GmbH Beckerstraße 31 09120 Chemnitz Telefon: +49 (0)371 35 55-0 Telefax: +49 (0)371 35 55-333	Vertriebsgebiet Nord Germany North Mannesmann Rexroth AG Vertriebsniederlassung Region Nord Gesch.ber. Rexroth Indramat Walsroder Str. 93 30853 Langenhagen Telefon: +49 (0) 511 72 66 57-0 Telefax: +49 (0) 511 72 66 57-93
Vertriebsgebiet West Germany West Mannesmann Rexroth AG Vertrieb Deutschland Regionalzentrum West Borsigstrasse 15 40880 Ratingen Telefon: +49 (0)2102 409-0 Telefax: +49 (0)2102 409-406	Vertriebsgebiet Mitte Germany Centre Mannesmann Rexroth AG Gesch.ber. Rexroth Indramat Lilistraße 14-18 63067 Offenbach Telefon: +49 (0) 69 82 00 90-0 Telefax: +49 (0) 69 82 00 90-80	Vertriebsgebiet Ost Germany East Mannesmann Rexroth AG GB Rexroth Indramat GmbH Holzhäuser Str. 122 04299 Leipzig Telefon: +49 (0)341 86 77-0 Telefax: +49 (0)341 86 77-219	Vertriebsgebiet Nord Germany North Rexroth Indramat GmbH Kieler Straße 212 22525 Hamburg Telefon: +49 (0)40 85 31 57-0 Telefax: +49 (0)40 85 31 57-15

Europa – Europe

vom Ausland: (0) nach Landeskennziffer weglassen, **Italien:** 0 nach Landeskennziffer mitwählen
from abroad: don't dial (0) after country code, **Italy:** dial 0 after country code

Austria Mannesmann Rexroth Ges.m.b.H. Gesch.ber. Rexroth Indramat Hägelingasse 3 1140 Wien Telefon: +43 (0)1 9852540-400 Telefax: +43 (0)1 9852540-93	Austria Mannesmann Rexroth G.m.b.H. Gesch.ber. Rexroth Indramat Industriepark 18 4061 Pasching Telefon: +43 (0)7221 605-0 Telefax: +43 (0)7221 605-21	Belgium Mannesmann Rexroth N.V.-S.A. Gesch.ber. Rexroth Indramat Industrielaan 8 1740 Ternat Telefon: +32 (0)2 5830719 Telefax: +32 (0)2 5830731 indramat@rexroth.be	Denmark BEC AS Zinkvej 6 8900 Randers Telefon: +45 (0)87 11 90 60 Telefax: +45 (0)87 11 90 61
Czech Republic Mannesmann-Rexroth, spol.s.r.o. Hviezdoslavova 5 627 00 Brno Telefon: +420 (0)5 48 126 358 Telefax: +420 (0)5 48 126 112	England Mannesmann Rexroth Ltd. Rexroth Indramat Division Broadway Lane, South Cerney Cirencester, Glos GL7 5UH Telefon: +44 (0)1285 863000 Telefax: +44 (0)1285 863030	Finland Rexroth Mecman Oy Rexroth Indramat division Ansatie 6 017 40 Vantaa Telefon: +358 (0)9 84 91-11 Telefax: +358 (0)9 84 91-13 60	France Mannesmann Rexroth S.A. Division Rexroth Indramat Parc des Barbanniers 4, Place du Village 92632 Gennevilliers Cedex Telefon: +33 (0)141 47 54 30 Telefax: +33 (0)147 94 69 41 Hotline: +33 (0)608 33 43 28
France Mannesmann Rexroth S.A. Division Rexroth Indramat 270, Avenue de Lardenne 31100 Toulouse Telefon: +33 (0)5 61 49 95 19 Telefax: +33 (0)5 61 31 00 41	France Mannesmann Rexroth S.A. Division Rexroth Indramat 91, Bd. Irène Joliot-Curie 69634 Vénissieux – Cedex Telefon: +33 (0)4 78 78 53 65 Telefax: +33 (0)4 78 78 53 62	Hungary Mannesmann Rexroth Kft. Angol utca 34 1149 Budapest Telefon: +36 (1) 364 00 02 Telefax: +36 (1) 383 19 80	Italy Mannesmann Rexroth S.p.A. Divisione Rexroth Indramat Via G. Di Vittoria, 1 20063 Cernusco S/N.MI Telefon: +39 02 2 365 270 Telefax: +39 02 700 408 252378
Italy Mannesmann Rexroth S.p.A. Divisione Rexroth Indramat Via Borgomanero, 11 10145 Torino Telefon: +39 011 7 50 38 11 Telefax: +39 011 7 71 01 90	Italy Mannesmann Rexroth S.p.A. Divisione Rexroth Indramat Via del Progresso, 16 (Zona Ind.) 35020 Padova Telefon: +39 049 8 70 13 70 Telefax: +39 049 8 70 13 77	Italy Mannesmann Rexroth S.p.A. Divisione Rexroth Indramat Via Mascia, 1 80053 Castellammare di Stabia NA Telefon: +39 081 8 71 57 00 Telefax: +39 081 8 71 68 85	Italy Mannesmann Rexroth S.p.A. Divisione Rexroth Indramat Viale Oriani, 38/A 40137 Bologna Telefon: +39 051 34 14 14 Telefax: +39 051 34 14 22
Netherlands Rexroth B.V. Kruisbroeksestraat 1 (P.O. Box 32) 5281 RV Boxtel Telefon: +31 (0)411 65 19 51 Telefax: +31 (0)411 65 14 83 indramat@hydrauldyne.nl	Netherlands Rexroth Hydrocare B.V. Kruisbroeksestraat 1 (P.O. Box 32) 5281 RV Boxtel Telefon: +31 (0)411 65 19 51 Telefax: +31 (0)411 67 78 14	Norway Rexroth Mecman AS Divisione Rexroth Indramat Berghagan 1 or: Box 3007 1405 Ski-Langhus 1402 Ski Telefon: +47 (0)64 86 41 00 Telefax: +47 (0)64 86 90 62	Poland Mannesmann Rexroth Sp.zo.o. Biuro Poznan ul. Dabrowskiego 81/85 60-529 Poznan Telefon: +48 061 847 67 99 Telefax: +48 061 847 64 02
Rumania Mannesmann Rexroth Sp.zo.o. Str. Drobety nr. 4-10, app. 14 70258 Bucuresti, Sector 2 Telefon: +40 (0)1 210 48 25 +40 (0)1 210 29 50 Telefax: +40 (0)1 210 29 52	Russia Tschudnenko E.B. Arsenia 22 153000 Ivanovo Telefon: +7 093 223 96 33 oder/or +7 093 223 95 48 Telefax: +7 093 223 46 01	Spain Mannesmann Rexroth S.A. Division Rexroth Indramat Centro Industrial Santiga Obradors s/n 08130 Santa Perpetua de Mogoda Barcelona Telefon: +34 9 37 47 94 00 Telefax: +34 9 37 47 94 01	Spain Goimendi S.A. Division Rexroth Indramat Parque Empresarial Zuatzu C/ Francisco Montagne no.2 20018 San Sebastian Telefon: +34 9 43 31 84 21 - service: +34 9 43 31 84 56 Telefax: +34 9 43 31 84 27 - service: +34 9 43 31 84 60 satindramat-goimendi@adegi.es
Sweden Rexroth Mecman Svenska AB Rexroth Indramat Division Varuvägen 7 125 81 Stockholm Telefon: +46 (0)8 727 92 00 Telefax: +46 (0)8 647 32 77	Slowenia Rexroth Indramat elektromotorji d.o.o. Otoki 21 64 228 Zelezniki Telefon: +386 64 61 73 32 Telefax: +386 64 64 71 50	Switzerland -East- Mannesmann Rexroth Schweiz AG Gesch.ber. Rexroth Indramat Gewerbstraße 3 8500 Frauenfeld Telefon: +41 (0)52 720 21 00 Telefax: +41 (0)52 720 21 11	Switzerland -West- Mannesmann Rexroth Suisse SA Département Rexroth Indramat Rue du village 1 1020 Renens Telefon: +41 (0)21 632 84 20 Telefax: +41 (0)21 632 84 21
Turkey Mannesmann Rexroth Hidropar A.S. Fevzi Cakmak Cad No. 3 34630 Sefaköy Istanbul Telefon: +90 212 541 60 70 Telefax: +90 212 599 34 07			

Africa, Asia, Australia – incl. Pacific Rim

vom Ausland:
from abroad:

(x) nach Landeskenziffer weglassen!
don't dial (x) after country code!

Australia AIMS - Australian Industrial Machinery Services Pty. Ltd. Unit 3/45 Horne ST Campbellfield, VIC 3061 Melbourne Telefon: +61 (0)3 93 59 02 28 Telefax: +61 (0)3 93 59 02 86	Australia Mannesmann Rexroth Pty. Ltd. No. 7, Endeavour Way Braeside Victoria, 31 95 Melbourne Telefon: +61 (0)3 95 80 39 33 Telefax: +61 (0)3 95 80 17 33 mel@rexroth.com.au	China Shanghai Mannesmann Rexroth Hydraulics & Automation Ltd. Wai Gaoqiao Free Trade Zone No.122, Fu Te Dong Yi Road Shanghai 200131 - P.R.China Telefon: +86 21 58 66 30 30 Telefax: +86 21 58 66 55 23	China Mannesmann Rexroth (China) Ltd. 15/F China World Trade Center 1, Jianguomenwai Avenue Beijing 100004, P.R.China Telefon: +86 10 65 05 03 80 Telefax: +86 10 65 05 03 79
China Mannesmann Rexroth (China) Ltd. A-5F., 123 Lian Shan Street Sha He Kou District Dalian 116 023, P.R.China Telefon: +86 411 46 78 930 Telefax: +86 411 46 78 932	China Mannesmann Rexroth (China) Ltd. Guangzhou Repres. Office Room 1014-1016, Metro Plaza, Tian He District, 183 Tian He Bei Rd Guangzhou 510075, P.R.China Telefon: +86 20 8755-0030 +86 20 8755-0011 Telefax: +86 20 8755-2387	Hongkong Rexroth (China) Ltd. 1/F., 19 Cheung Shun Street Cheung Sha Wan, Kowloon, Hongkong Telefon: +852 22 62 51 00 Telefax: +852 27 41 33 44	India Mannesmann Rexroth (India) Ltd. Rexroth Indramat Division Plot. A-58, TTC Industrial Area Thane Turbhe Midc Road Mahape Village Navi Mumbai - 400 701 Telefon: +91 (0)22 7 61 46 22 Telefax: +91 (0)22 7 68 15 31
India Mannesmann Rexroth (India) Ltd. Rexroth Indramat Division Plot. 96, Phase III Peenya Industrial Area Bangalore - 560058 Telefon: +91 (0)80 8 39 73 74 Telefax: +91 (0)80 8 39 43 45	Indonesia PT. Rexroth Wijayakusuma Jl. Raya Bekasi Km 21 Pulogadung Jakarta Timur 13920 Telefon: +62 21 4 61 04 87 +62 21 4 61 04 88 Telefax: +62 21 4 60 01 52	Japan Rexroth Automation Co., Ltd. Service Center Japan Yutakagaoka 1810, Meito-ku, NAGOYA 465-0035, Japan Telefon: +81 (0)52 777 88 41 +81 (0)52 777 88 53 +81 (0)52 777 88 79 Telefax: +81 (0)52 777 89 01	Japan Rexroth Automation Co., Ltd. Rexroth Indramat Division 1F, I.R. Building Nakamachidai 4-26-44, Tsuzuki-ku YOKOHAMA 224-0041, Japan Telefon: +81 (0)45 942 72 10 Telefax: +81 (0)45 942 03 41
Korea Mannesmann Rexroth-Korea Ltd. Rexroth Indramat Division 1500-12 Dadae-Dong- Saha-Ku Pusan, 604-050 Republic of South Korea Telefon: +82 (0)51 26 00 741 Telefax: +82 (0)51 26 00 747 gyhan@rexrothkorea.co.kr	South Africa TECTRA Automation (Pty) Ltd. 28 Banfield Road, Industria North RSA - Maraisburg 1700 Telefon: +27 (0)11 673 20 80 Telefax: +27 (0)11 673 72 69	Taiwan Rexroth Uchida Co., Ltd. No.17, Lane 136, Cheng Bei 1 Rd., Yungkang, Tainan Hsien Taiwan, R.O.C. Telefon: +886 (0)6 25 36 565 Telefax: +886 (0)6 25 34 754	Thailand NC Advance Technologies Co. Ltd. 59/76 Moo 9 Soi Ramintra 34 Ramintra Road, Tharang, Bangkhen Bangkok 10220 Telefon: +66 2 943 70 62 +66 2 943 71 21 Telefax: +66 2 509 23 62 sonkawin@hotmail.com

Nordamerika – North America

<p>USA</p> <p>Mannesmann Rexroth Corporation Rexroth Indramat Division 5150 Prairie Stone Parkway Hoffman Estates, IL 60192-3707</p> <p>Competence Centre America</p> <p>Telefon: +1 847 6 45 36 00 Telefax: +1 847 6 45 62 01 service@indramat.com</p>	<p>USA</p> <p>Mannesmann Rexroth Corporation Rexroth Indramat Division Central Region Technical Center Auburn Hills, MI 48326</p> <p>Telefon: +1 248 3 93 33 30 Telefax: +1 248 3 93 29 06</p>	<p>USA</p> <p>Mannesmann Rexroth Corporation Rexroth Indramat Division Southeastern Technical Center 3625 Swiftwater Park Drive Suwanee, Georgia 30174</p> <p>Telefon: +1 770 9 32 32 00 Telefax: +1 770 9 32 19 03</p>	<p>USA</p> <p>HOTLINE</p> <p>- 7 days x 24hrs -</p> <p>+1-800-860-1055</p>
<p>USA</p> <p>Mannesmann Rexroth Corporation Rexroth Indramat Division Charlotte Regional Sales Office 14001 South Lakes Drive Charlotte, North Carolina 28273</p> <p>Telefon: +1 704 5 83 97 62 +1 704 5 83 14 86</p>	<p>USA</p> <p>Mannesmann Rexroth Corporation Rexroth Indramat Division Northeastern Technical Center 99 Rainbow Road East Granby, Connecticut 06026</p> <p>Telefon: +1 860 8 44 83 77 Telefax: +1 860 8 44 85 95</p>	<p>Canada East</p> <p>Basic Technologies Corporation Burlington Division 3426 Mainway Drive Burlington, Ontario Canada L7M 1A8</p> <p>Telefon: +1 905 335 55 11 Telefax: +1 905 335-41 84</p>	<p>Canada West</p> <p>Basic Automation Burnaby 5345 Goring St. Burnaby, British Columbia Canada V7J 1R1</p> <p>Tel. +1 604 205-5777 Fax +1 604 205-6944 dave.gunby@basic.ca</p>

Südamerika – South America

<p>Argentina</p> <p>Mannesmann Rexroth S.A.I.C. Division Rexroth Indramat Acassusso 48 41/7 RA - 1605 Munro (Buenos Aires)</p> <p>Telefon: +54 (0)11 4756 01 40 Telefax: +54 (0)11 4762 6862 mannesmann@mannesmannsaic.com.ar</p>	<p>Argentina</p> <p>NAKASE Servicio Tecnico CNC Calle 49, No. 5764/66 RA - 1653 Villa Balester Prov. - Buenos Aires</p> <p>Telefon: +54 (0) 11 4768 36 43 Telefax: +54 (0) 11 4768 24 13 nakase@usa.net nakase@infovia.com.ar</p>	<p>Brazil</p> <p>Mannesmann Rexroth Automação Ltda. Divisão Rexroth Indramat Rua Georg Rexroth, 609 Vila Padre Anchieta BR - 09951-270 Diadema-SP [Caixa Postal 377] [BR-09901-970 Diadema-SP]</p> <p>Telefon: +55 (0)11 4075 90 60 +55 (0)11 4075 90 70 Telefax: +55 (0)11 4075 35 52 awittwer@rexroth.com.br</p>	<p>Brazil</p> <p>Mannesmann Rexroth Automação Ltda. Divisão Rexroth Indramat R. Dr.Humberto Pinheiro Vieira, 100 Distrito Industrial BR - 89220-390 Joinville - SC [Caixa Postal 1273]</p> <p>Tel./Fax: +55 (0)47 473 58 33 Mobil: +55 (0)47 974 66 45 prochnow@zaz.com.br</p>
<p>Mexico</p> <p>Mannesmann Rexroth Mexico S.A. de C.V. Calle Neptuno 72 Unidad Ind. Vallejo MEX - 07700 Mexico, D.F.</p> <p>Telefon: +52 5 754 17 11 +52 5 754 36 84 +52 5 754 12 60 Telefax: +52 5 754 50 73 +52 5 752 59 43</p>			

Notizen / Notes

13 Index

A

additional bleeder module

- characteristics 6-4
- dimension drawing 6-8
- front view 6-7
- operate and monitor 6-5
- technical data 6-4
- unit arrangement 6-4

additional capacitance module

- arrangement 6-2
- characteristics 6-2
- dimension drawing 6-4
- front view 6-3
- maximum additional capacitance 6-2
- operate and monitor 6-2

appropriate use

- introduction 2-1
- use 2-2

areas of application 1-3

- auxiliary capacitance
- calculating 5-5

B

basic losses 4-7

- bleeder power *see* power data *and* data sheet

C

calculating

- connected load 5-8
- continuous regenerated power 5-6
- peak regenerated power 5-7

combining filter

- data sheet 4-8

commutation choke

- data sheet 4-8

conditions of use

- HVE 4-4
- HVR 4-7

control cabinet check 8-22

controller arrangement 7-9

cooling unit

- configuration 7-5

D

data sheet

- combining filter 4-8
- commutation choke 4-8
- HVE 4-4
- HVR 4-7

DC bus choke 6-1

- dimension drawing 6-1
- technical data 6-1

DC bus continuous power *see* data sheet *and* power data

- calculate 5-1
- for main drives 5-3
- for servo drives 5-3
- for spindle and servo drives in machine tools 5-4
- increase 5-1

DC bus dynamic brake 9-2

DC bus peak power

- calculating 5-4

DC bus power *see* power data *and* data sheet

increase 6-2
dimension drawing
DC bus choke 6-1

E

electromagnetic compatibility *see* interference elimination
EMC *see* interference elimination

H

HVE

conditions of use 4-4
data sheet 4-4
power data 4-2
power loss 4-4
short-term output 4-3
technical data 4-1

HVR

conditions of use 4-7
data sheet 4-7
power data 4-5
power loss 4-7
short-term output 4-6
technical data 4-5

HZB *see* additional bleeder module

HZF *see* combining filter

HZK *see* additional capacitance module

I

inappropriate use 2-2

consequences, discharge of liability 2-1

increase bleeder power *see* additional bleeder module

interference elimination 8-21

interference emission 8-21

interference suppression 8-21

K

KD *see* commutation choke

L

loss of heat

dimension cooling unit 7-4

example calculation 7-3

M

mains supply

introduction 5-1

manage braking energies *see* additional bleeder module

mechanical power *see* power data *and* data sheet

modified conditions of use 7-1

mounting conditions 7-8

mounting position 7-9

P

power data

HVE 4-2

HVR 4-5

power loss

HVE 4-4

HVR 4-7

power supply unit

areas of application 1-3

construction 1-2

features 1-4
working mode 1-2

R

reduce heat loss 5-5
reduce loss of heat *see* additional capacitance module
regenerated energy *see* auxiliary capacitance
calculating 5-5
regenerated power *see* power data *and* data sheet
resistance to interference 8-21

S

Safety Instructions 3-1
short-term output
HVE 4-3
HVR 4-6
system overview 1-1

T

technical data
DC bus choke 6-1
HVE 4-1
HVR 4-5

U

use *see* appropriate use *and* *see* inappropriate use

Notes

280641

Printed in Germany

