

# MDC2 ARTEH DC SPINDLE UNIT

## Maintenance Manual

### CONTENTS

1. Main features .....	2
2. Composition .....	2
3. Operating conditions .....	2
4. Technical specifications .....	2
5. General structure and operation principles .....	2
6. Interface .....	5
6.1. Interface description .....	5
6.2. Connection diagram .....	7
7. Installation of DC spindle unit .....	9
7.1. Installation conditions .....	9
7.2. Outer dimensions .....	9
8. Electronic self-protections .....	9
9. Adjustment of DC spindle drive unit .....	10
9.1. Test equipment .....	11
9.2. Adjustment method .....	11

The MDC2 ARTEH DC spindle drive systems have been specifically developed for NC machine tools.

### 1. Main features.

- Rated power up to maximal speed.
- Two zone regulation.
- Dynamic current limitation.
- Ability to overload safe for the motor.
- Two stage torque limit.
- Self-synchronization.
- Electric spindle orientation control is applicable (option).
- DA converter (option).

### 2. Composition.

The ARTEH DC spindle drive system consists of the following units and parts:

- (1). DC brush motor with built-in tachogenerator  $0,02 \pm 1\%$  V / 1 min<sup>-1</sup> or  $0,004 \pm 1\%$  V / 1 min<sup>-1</sup>.
- (2). Thyristor DC servo unit.
- (3). 3 - phase choke.

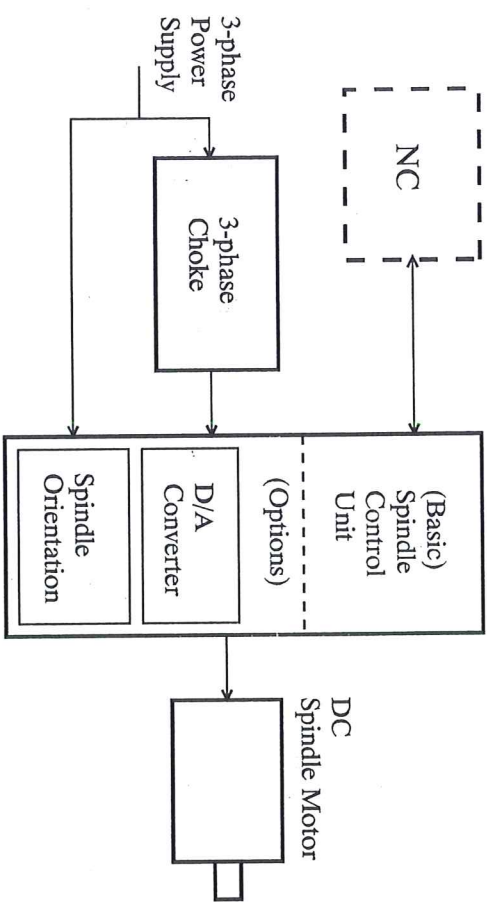

Fig. 1. Composition.

### 3. Operating Conditions.

- Ambient temperature - 0°C up to 40°C
- Max. humidity at 30°C - 80%
- Ambient atmosphere - flameproof, without conducting dust or aggressive gasses in concentration causing metal and insulation destruction.

### 4. Technical specifications.

Table 1 shows all technical data concerning the drive system.

### 5. General structure and operation principles.

Two zone speed control is performed (see fig. 2). In the first zone (up to nominal speed  $W_{nom}$ ) the control is accomplished by variation of the armature voltage while the field stays the same. The torque  $M$  in this zone is constant.

In the second zone, where the speed exceeds its nominal value  $W_{nom}$  the armature voltage is held constant equal to the maximal value for the motor, but the field is variable. In this zone the power  $P$  is kept constant.

The block diagram of the MDC1 DC spindle drive system is shown in fig. 3. The elements designation is as follows:

- 1 - Ramp generator.
- 2 - PID speed controller.
- 3 - Current limitation network.
- 4 - PID armature current controller.
- 5 - Firing control of armature bridge.
- 6 - Speed correction network.
- 7 - Dynamic current limitation.
- 8 - Armature current feedback.
- 9 - Armature current feedback Gain.
- 10 - Speed feedback Gain.
- 11 - Field current controller.
- 12 - Firing control of field bridges.
- 13 - Field current feedback.
- 14 - Field current feedback Gain.
- 15 - Armature voltage feedback.
- 16 - Armature voltage feedback Gain.

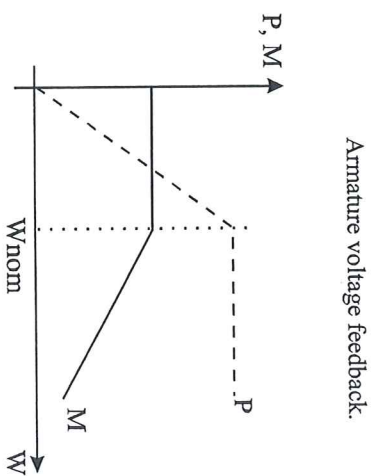
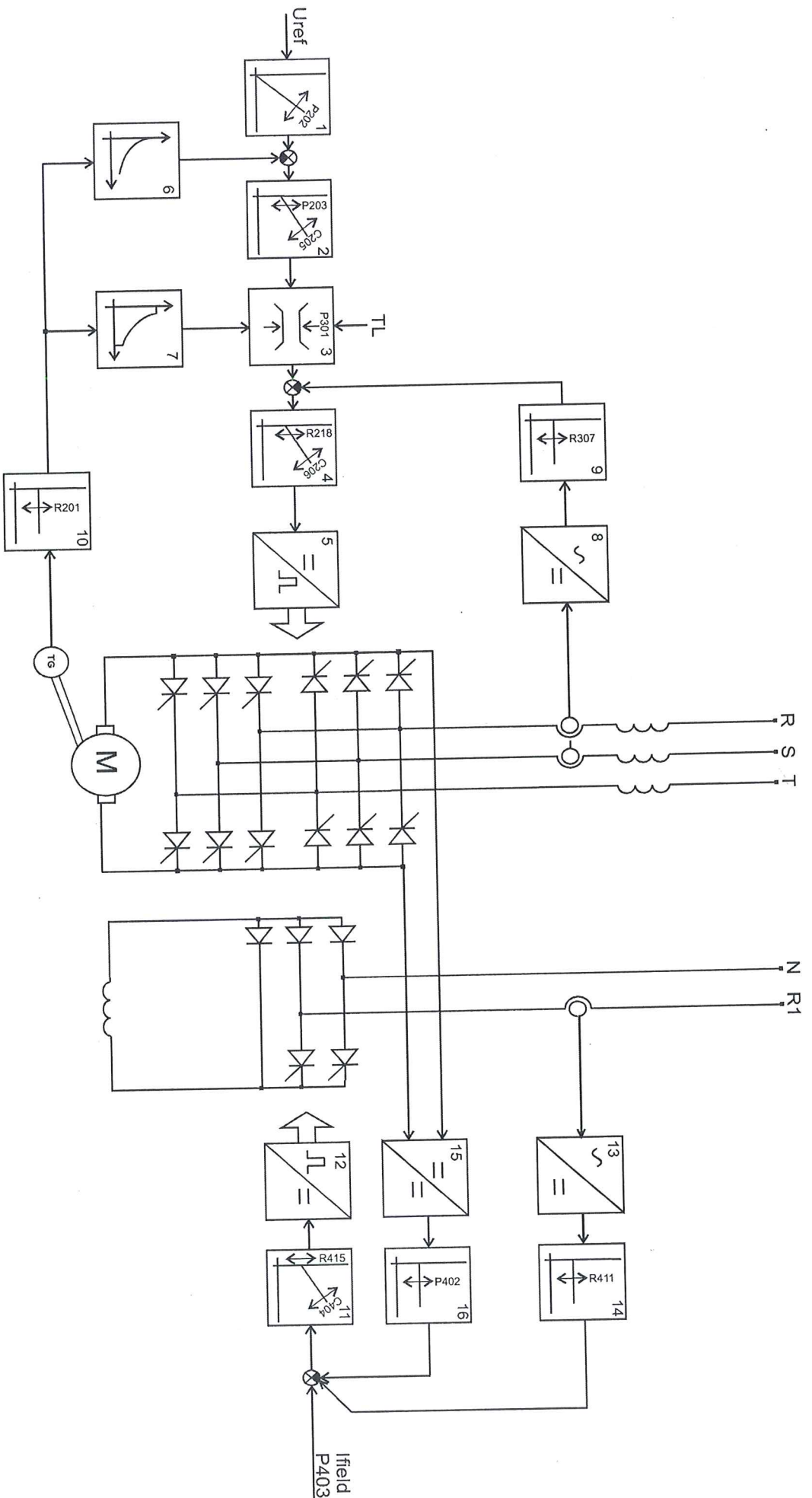

Fig. 2. Two zone speed control.

Table 1. Technical data.

Motor type	MP132SA	MP132SB	MP112M	MP112L	MP132M	MP132MA	MP132LA	MP132MB	MP160M	MP160MA	MP160L
Spindle unit type	MDC1-5.5	MDC1-5.5	MDC1-5.5	MDC1-7.5	MDC1-11	MDC1-11	MDC1-15	MDC1-18.5	MDC1-22	MDC1-22	MDC1-30
Choke type	PK-0525	PK-0525	PK-0525	PK-0548	PK-0548	PK-0548	PK-05410	PK-02510	PK-02612	PK-02612	PK-02715
Rated power, kW	5.5	5.5	5.5	7.5	11	11	15	18.5	22	22	30
Power supply, V	3x380, 50Hz	3x380, 50Hz	3x380, 50Hz	3x380, 50Hz	3x380, 50Hz	3x380, 50Hz	3x380, 50Hz	3x380, 50Hz	3x380, 50Hz	3x380, 50Hz	3x380, 50Hz
Rated armature current, A	20	19	20	25	34	34	46	56	67	64	100
Maximal armature current, A	40	38	40	50	68	68	92	112	132	128	150
Maximal armature voltage, V	400	400	400	400	400	400	400	400	400	400	400
Rated field current, A	2.5	2.5	4	4.5	5.8	3.5	5	3.5	6.5	6.5	6
Maximal field voltage, V	180	180	180	180	110	180	180	180	180	180	180
Rated rotation speed, n/min <sup>-1</sup>	1000	1000	1000	1000	1000	1000	1000	1000	1000	1000	1000
Maximal rotation speed, n/min <sup>-1</sup>	4500	5500	5500	5500	3500	4500	4500	4500	4000	4500	4000
Speed control range	1:1000	1:1000	1:1000	1:1000	1:1000	1:1000	1:1000	1:1000	1:1000	1:1000	1:1000
Speed reference signal, V	+/-10	+/-10	+/-10	+/-10	+/-10	+/-10	+/-10	+/-10	+/-10	+/-10	+/-10
Mode of operation	continuous	continuous	continuous	continuous	continuous	continuous	continuous	continuous	continuous	continuous	continuous
Degree of protection	IP20	IP20	IP20	IP20	IP20	IP20	IP20	IP20	IP20	IP20	IP20



**Fig. 3. Block diagram.**

- 1 - Ramp generator; 2 - PID speed controller; 3 - Current limitation network; 4 - PID armature current controller; 5 - Firing control of armature bridge; 6 - Speed correction network; 7 - Dynamic current limitation; 8 - Armature current feedback; 9 - Armature current feedback gain; 10 - Speed feedback gain; 11 - Field current controller; 12 - Firing control of field bridges; 13 - Field current feedback; 14 - Armature voltage feedback gain; 15 - Armature voltage feedback; 16 - Armature voltage feedback gain.



6. Interface.  
6.1. Interface description.

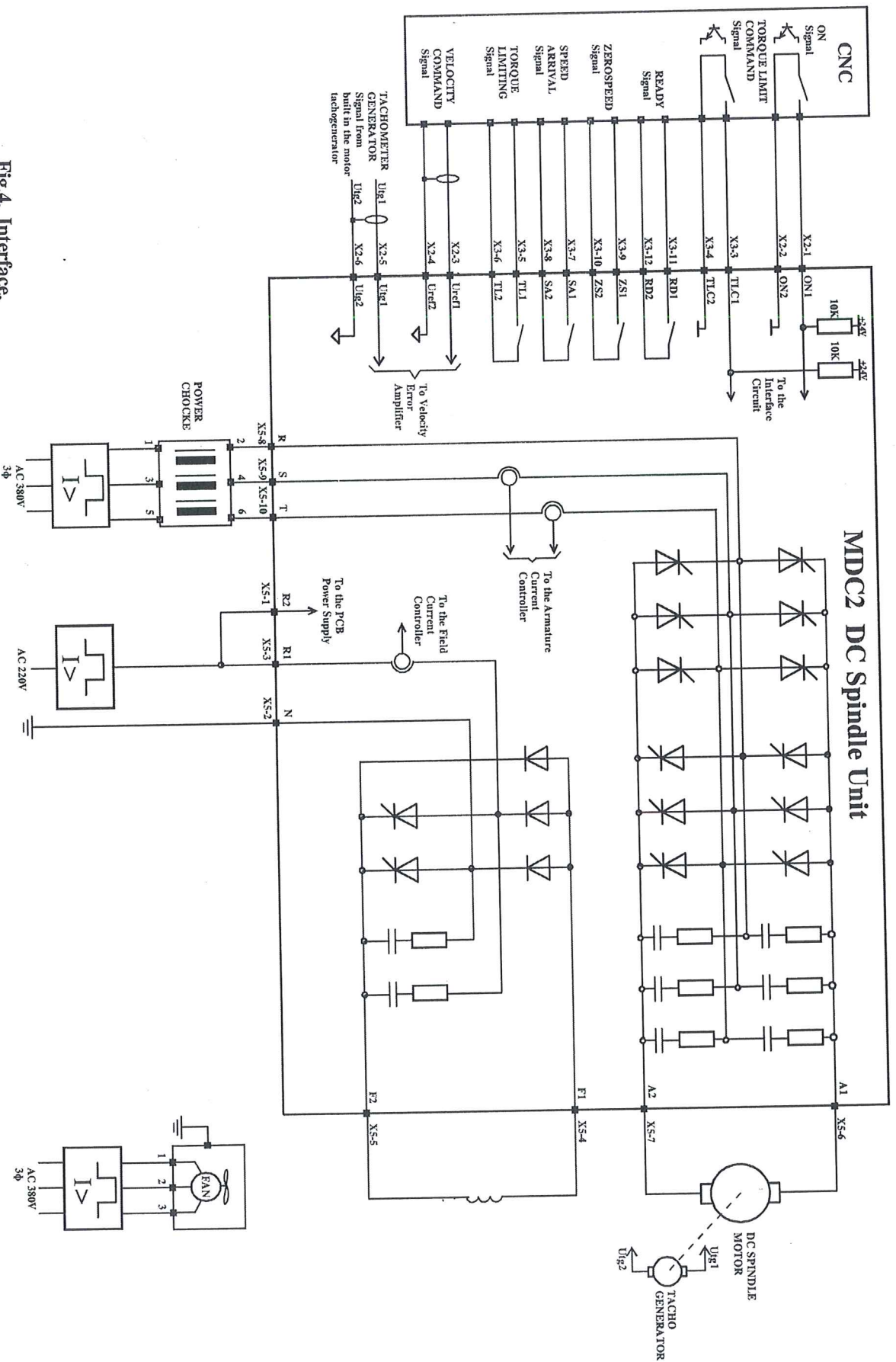

Fig.4. Interface.

The location of the interface connectors is shown in fig. 5.  
Table 2 shows details of the interface signals.

Signal	Designation	Connector	Significant Level	Remark
<b>Spindle control input signals</b>				
Firing control signal	ON1 ON2	X2-1 X2-2	Contact ON	Thyristors are fired when this contact signal is turned ON. X2-2 is connected to ground. ON signal is LED indicated.
Velocity command voltage	Uref1 Uref2	X2-3 X2-4	Analog signal	Analog voltage 0 to $\pm 10$ V has to be applied across pins X2-3 and X2-4. X2-3 is the active pin. X2-4 is connected to ground (reference point). The motor is not rotated when the velocity command voltage only is applied. It rotates if firing control signal was given. When the velocity command input (Uref1) is open the same condition as in command voltage 0 V is obtained. The shield of the cable must be connected to X2-4.
Tachogenerator signal	Ufg1 Ufg2	X2-5 X2-6	Analog signal	Velocity feedback signal. X2-5 (Ufg1) is the active terminal. X2-6 (Ufg2) is connected to ground. The shield of the cable must be connected to X2-6.
Torque limit command signal	TLC1 TLC2	X3-3 X3-4	Contact ON	When the TLC signal turns ON (closed) the torque is limited by 75% to 95%. It is adjustable by the P301 variable resistor on PCB. The torque limiting signal (TL1, 2) is sent outside immediately when the torque is limited. X3-4 is connected to ground.

**Table 2. Details of signals - continued.**

Signal	Designation	Connector	Significant Level	Remark
<b>Spindle control output signals</b>				
Spindle unit ready signal	RD1 RD2	X3-11 X3-12	Contact ON	Approximately 0,5 sec after power turn - ON X3-11 and X3-12 pins are short connected by a reed relay if the CP protection is not active. Spindle ready signal is LED indicated.
Zero-speed detecting signal	ZS1 ZS2	X3-9 X3-10	Contact ON	If actual rotation speed of the spindle motor is reduced to be lower than the zerospeed detection point, the contact is turned ON (closed). The zerospeed detection point is at 0,75% of the maximum speed.
Speed arrival signal	SA1 SA2	X3-7 X3-8	Contact ON	The contact is turned ON (closed) when the actual rotation speed of the spindle motor reaches a certain preset range with reference to the command speed. The detection range is set to $\pm 15\%$ of the command speed.
Torque limiting signal	TL1 TL2	X3-5 X3-6	Contact ON	The contact is turned ON (closed) immediately when the TLC signal was given.
<b>Indications on Speedometer and Loadmeter</b>				
Speed indication voltage	AOS1 AOS2	X2-7 X2-8	Analog signal	A DC voltage proportional to the rotation speed is outputted, irrespective of the forward or reverse rotation of the motor. A +10 V is outputted at the maximum revolution. X2-8 is connected to the ground (ref. point). X2-7 is the active pin. The permissible current is 10 mA.
Armature current indicating voltage	AOC1 AOC2	X2-9 X2-10	Analog signal	A DC voltage proportional to the armature current is outputted. The relation between AOC voltage and actual armature current is shown in fig. 5. X2-10 is connected to the ground (ref. point). X2-9 is the active pin. The permissible current is 10 mA.
Regulated power supply	+15 V -15 V	X2-11 X2-12		This power supply is used when the analog velocity command is given by using an external variable resistor for manual input. The $\pm 15$ V power supply can employ maximum 50 mA.

- Note:
1. The permissible DC current through all reedrelay contacts is 50 mA.
  2. X3-1 and X3-2 connectors are reserved for future upgrade.

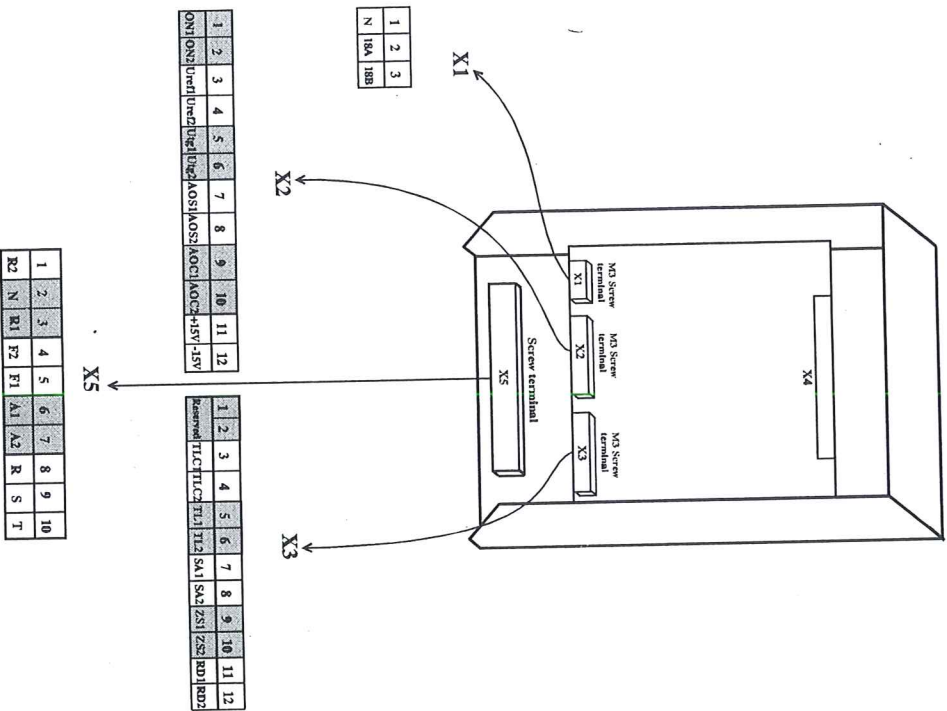

Fig. 5. The location of the interface connectors.

## 6.2. Connection diagram.

Connections between DC spindle servo unit, DC spindle motor, CNC and mains supply are shown in fig. 6.

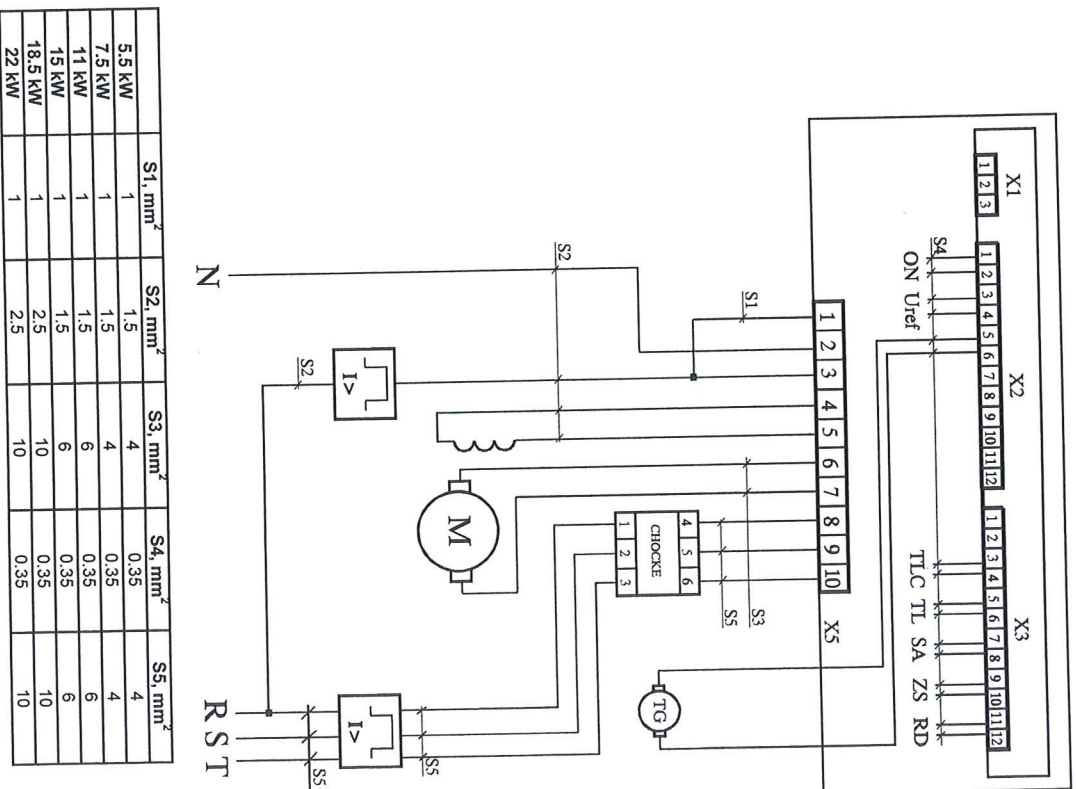

Fig. 6 Connection diagram.

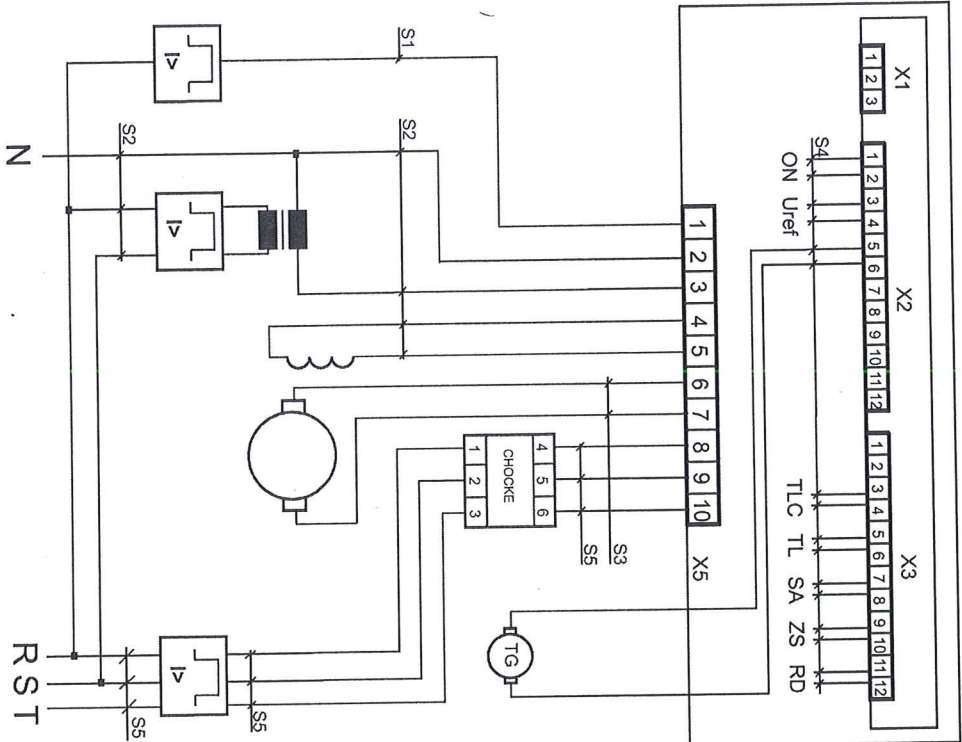

Fig. 7 Connection diagram whit power transformer.

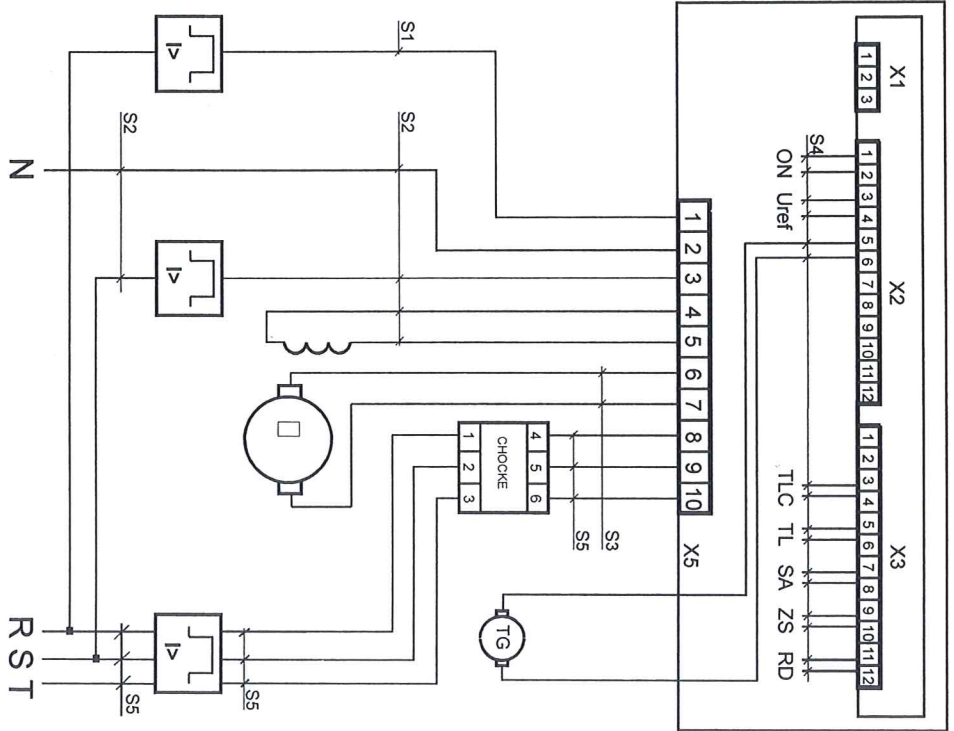

Fig. 7a Connection diagram for field voltage above 220V without power transformer.



**Notes:**

1. Use wires as short as possible.
2. The signal wires must be placed as far as possible from the power cables.
3. Utilization of shielded wire is recommended for connection between NC system and reference inputs  $U_{ref1}$  and  $U_{ref2}$  of the drive unit. The shield has to be connected to the X2-4 pin.
4. Utilization of shielded wire is also recommended for connection between tachogenerator and speed feedback inputs  $U_{fg1}$  and  $U_{fg2}$  of the drive unit. The shield has to be connected to the X2-6 pin.

**7. Installation of DC spindle unit.**

**7.1. Installation conditions.**

The spindle drive modules are intended for installation in metal cabinets. The ventilation system of the cabinet must ensure vertical air circulation through thyristor sections of the drive.

**7.2. Outer dimensions.**

The outer dimensions of the drive are shown in fig.8.

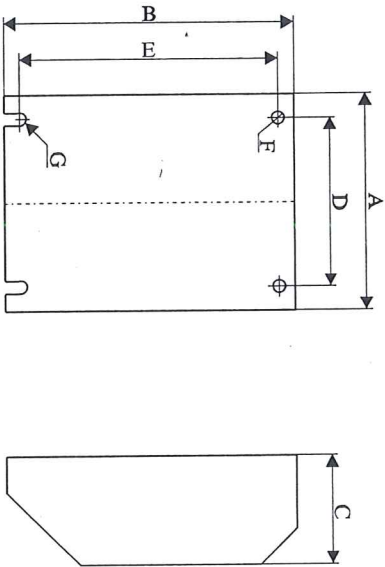

Type	A mm	B mm	C mm	D mm	E mm	F mm	G mm
MDC2-5-5-18.5	190	380	125	150	355	10	R5

Fig.8. Outer dimensions.

**8. Electronic self - protections.**

Several electronic protections are employed to secure reliable drive operation. Actuation of any one causes immediate disablement of the drive through stopping the firing pulses to the thyristors. The operation of any protection can be disabled by opening the corresponding DIP switch.

All protections are LED indicated.

The location of the LEDs and DIP switches on the PCB is shown in fig. 9. Table 3 shows all details concerning the protections.

Table 3. Protections .

Protection	Description	Display
FL	Field loss.	LED D810
CP	Phase failure. The CP protection is actuated if one of the following events occurs: - one of the main phases is absent - a regulated supply (+15V, - 15V, +5V ) is absent or considerably decreased.	LED D809
EE	Error Excess. An alarm is issued in case of continuous drive operation with armature current exceeding by 25% its maximal value.	LED D808
TG	Tachometer Generator loss. An alarm is issued if the velocity feedback signal is lost.	LED D807
OS	Overspeed detection. If the speed exceeds 115 % of the rated maximum speed, an alarm is issued.	LED D806
OC	Overcurrent detection. If the armature current exceeds 150 % of the rated maximum current, an alarm is issued.	LED D805

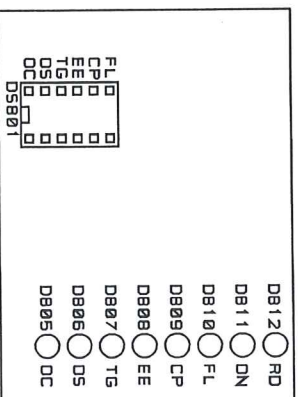

Fig.9. The location of the LEDs and DIP switches on the PCB.

### 9. Adjustment of the DC spindle drive unit.

All necessary adjustments of the drive unit are implemented by the manufacturer. Readjustment may be done when it is needed. For this purpose variable resistors are employed and test points are implanted to facilitate observation of the most important signals.

Table 4 shows the designation of the variable resistors.

Table 5 shows the designation of the test points.

The location of the variable resistors and test points is shown in fig. 10.

**Table 4. Variable resistors.**

Item	Designation	Test point
P201	Speed feedback gain adjustment	CP201
P202	Acceleration and deceleration adjustment (ramp generator)	CP204
P203	Speed controller gain adjustment	-
P204	Offset of the ramp generator	CP204
P205	Offset of the speed controller	-
P301	Level of torque limit when TLLC command was given	-
P401	Balancing of the armature voltage feedback difference amplifier	CP401
P402	Second zone adjustment	CP402
P403	Field current adjustment	CP403
P501	Armature current limitation	-
P502	Initial angle	-

**Table 5. Test points.**

Test point	Signal	Remark
CP101	Reference point (GROUND)	0V
CP102	+24V	
CP103	-24V	
CP104	+15V	
CP105	-15V	
CP106	+5V	
CP201	Tachogenerator voltage	-10V to +10V
CP202	Speed controller output	-11V to +11V
CP203	Armature current controller output	-12V to +12V
CP204	RAMP output	-10V to +10V
CP303	Armature current	
CP301	Armature current feedback	2V/ maximal armature current
CP302	Armature current limitation	11V/ 0 rpm, 4V/ maximal speed
CP401	Armature voltage feedback	
CP402	Second zone of control	
CP403	Field current feedback	6V/ nominal field current
CP404	Analog voltage proportional to the firing angle of field thyristor bridge	0V to +5V
CP501	Analog voltage proportional to the firing angle of armature thyristor bridge	0V to +5V

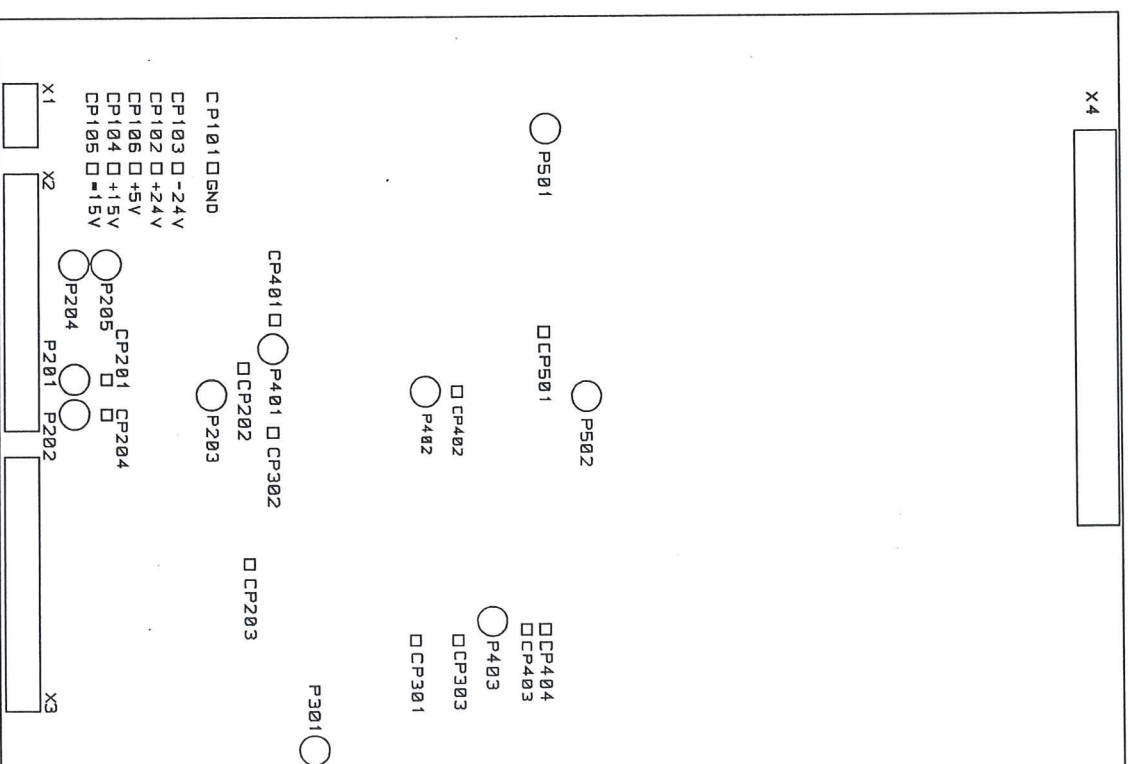

**Fig. 10. Location of the variable resistors and test points.**

### 9.1. Test equipment.

Test equipment required for setting and adjustment of the DC spindle servo unit is as follows:

1. DC voltmeter.
2. Variable DC voltage generator with range  $\pm 10V$  and output impedance up to 2 k $\Omega$ .

### 9.2. Adjustment method.

When the DC spindle drive unit is installed and the power and interface cables are connected the following steps have to be performed for it proper adjustment:

1. Short jumpers  $J_{202}$  and  $J_{203}$  .

This makes the velocity and armature current regulators proportional.

2. Disable the TG tachometer loss protection turning OFF the corresponding switch located at the DS801 DIP switches.
3. Disconnect the Ufg1 signal. This disables the speed feedback.
4. Turn ON the power.

Check the rotation of the fan motor. If it is not correct, turn OFF the power and exchange two of fan motor power supply phases.

Then turn ON the power again.

5. The RD (Ready) LED has to light.

If it is not, there is some trouble or wrong connection.

Turn OFF the power and check all connections again.

6. After the RD (Ready) LED is lighted give the ON (firing control) signal. The ON LED is lighted and the thyristors are fired.

7. Give Uref1 (velocity command) signal. The motor begins to rotate.

Change the polarity of the Uref1 signal. The direction of the motor rotation has to be changed.

8. Check the polarities of the voltages at the CP204 test point and of the Ufg1 signal. They has to be opposite. If they are not, exchange the connections of the tachogenerator.

9. Turn OFF the power supply.

Connect the Ufg1 signal to the X2-5 pin.

Open the  $J_{202}$  and  $J_{203}$  jumpers.

10. Turn ON the power supply.

Use the P203 variable resistor to adjust the speed controller gain and the P202 variable resistor to adjust the ramp generator according the mechanical load.



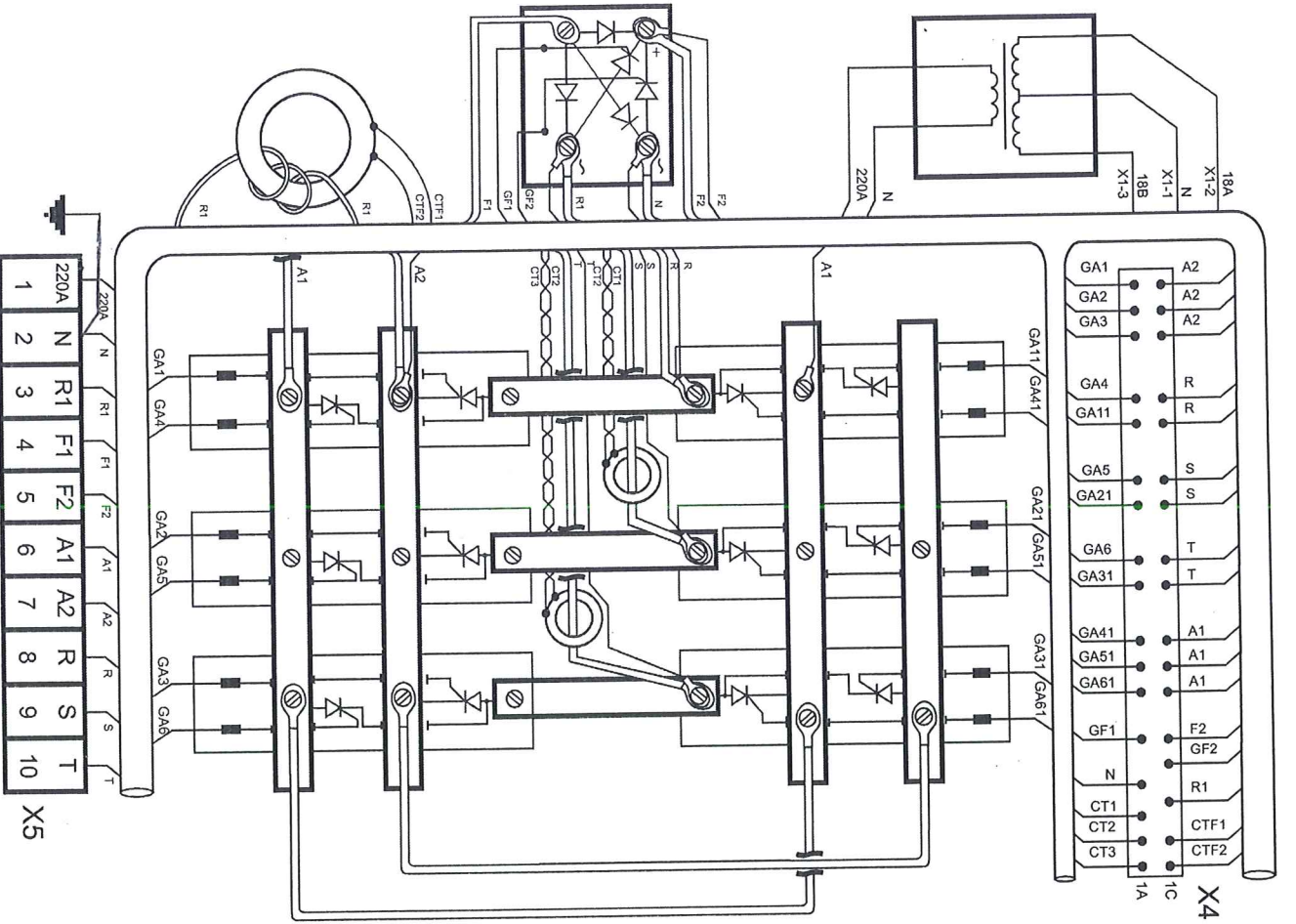

Fig. 11. Location of the thyristors up to 18kW.

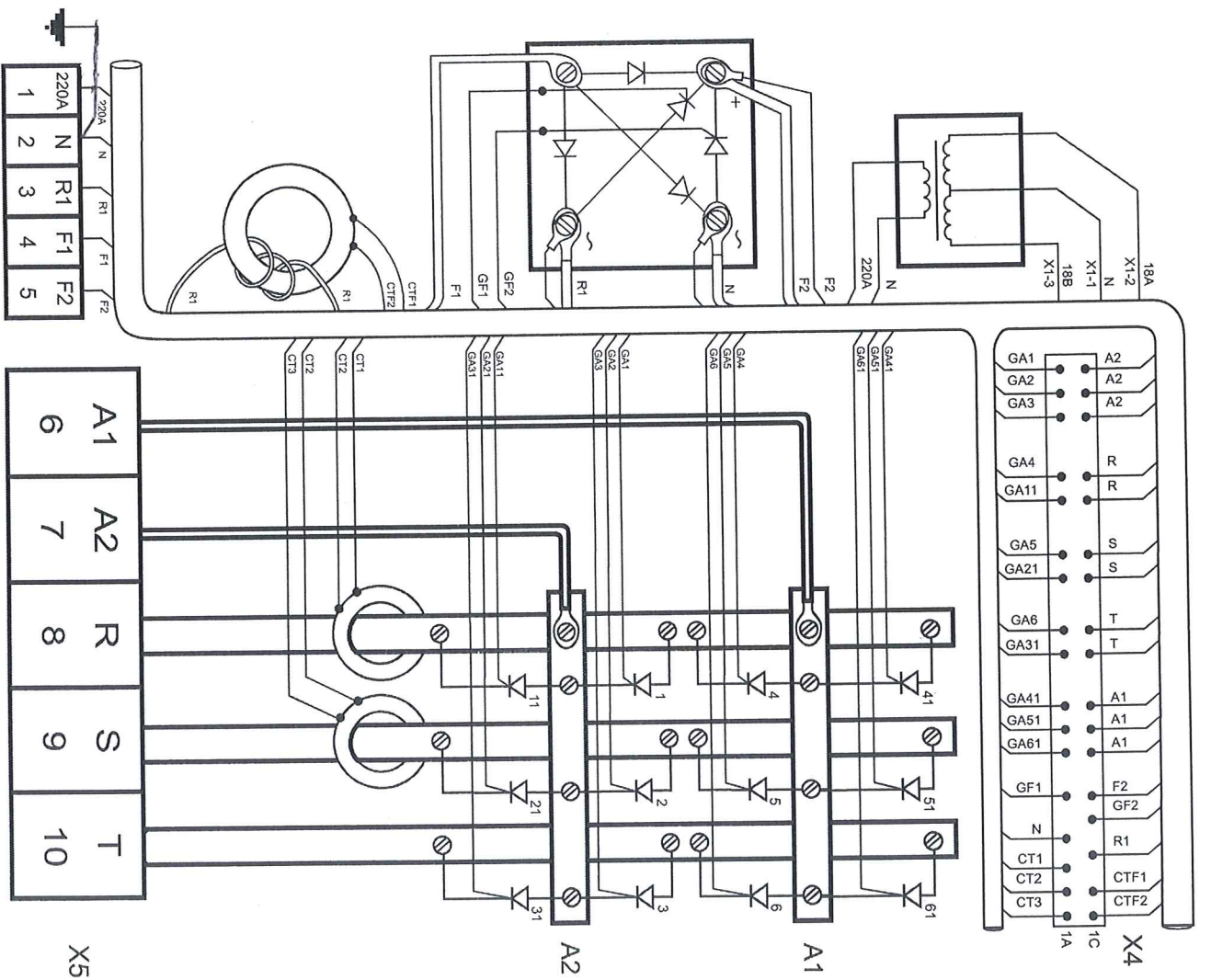
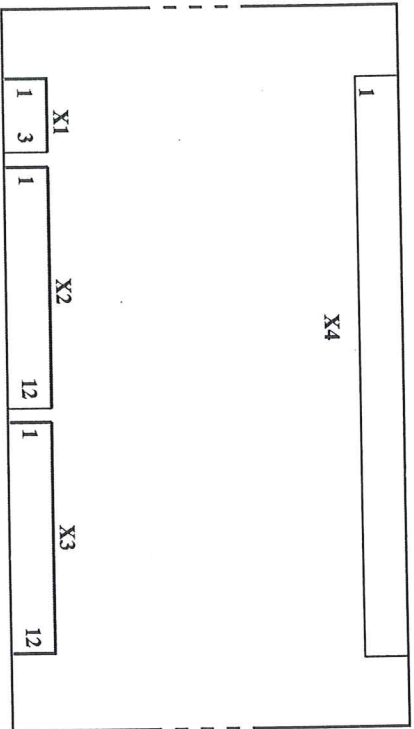

Fig. 12. Location of the thyristors up to 75kW.





X1-2 18A (2A4)  
 X1-3 18B (2B2)  
 X1-1 0V

X2-1 ON1 (9K3)  
 X2-2 ON2  
 X2-3 Urc1 (3G0)  
 X2-4 Urc2  
 X2-5 Urc1 (3B1)  
 X2-6 Urc2  
 X2-7 AOS (3C3)(4C4)(9D3)(10C0)  
 X2-8  
 X2-9 AOC (4B1)(4D3)(9B0)  
 X2-10  
 X2-11 #15  
 X2-12

X3-1 RESERVED  
 X3-2  
 X3-3 TL01 (4L4)  
 X3-4 TL02  
 X3-5 TL1 (4K4)  
 X3-6 TL2 (4L3)  
 X3-7 SA1 (10D4)  
 X3-8 SA2 (10E2)  
 X3-9 ZS1 (10B1)  
 X3-10 ZS2 (10B4)  
 X3-11 RD1 (9C1)  
 X3-12 RD2 (9C4)

(7H1) GA1 X4-2 X4-1 A2 (7K1)(SD0)  
 (7H2) GA2 X4-4 X4-3  
 (7H3) GA3 X4-6 X4-5  
 (7C4) GA4 X4-8 X4-7 R (7D0)(8C3)(2L2)  
 (8C3) GA11 X4-10 X4-9  
 (7D3) GA5 X4-12 X4-11 S (7E0)(8D4)(2H2)  
 (8D3) GA21 X4-14 X4-13  
 (7E3) GA6 X4-16 X4-15 T (7G0)(8F1)(2L4)  
 (8E3) GA31 X4-18 X4-17  
 (8H2) GA41 X4-20 X4-19 A1 (7C1)(5E3)  
 (8H4) GA51 X4-22 X4-21  
 (8J1) GA61 X4-24 X4-23  
 (11E2) GF1 X4-26 X4-25 F2 (11E3)  
 (11E0) GF2 X4-28  
 (11H3) N X4-34 X4-27 R1 (11H1)  
 (4B4) CT1 X4-30  
 (4C0) CT2 X4-32 X4-29 CTR1 (5R2)  
 (4C2) CT3 X4-33 X4-31 ACND

MDC2		ArtTech
SHEET 1 OF 13		
		20 June 2000

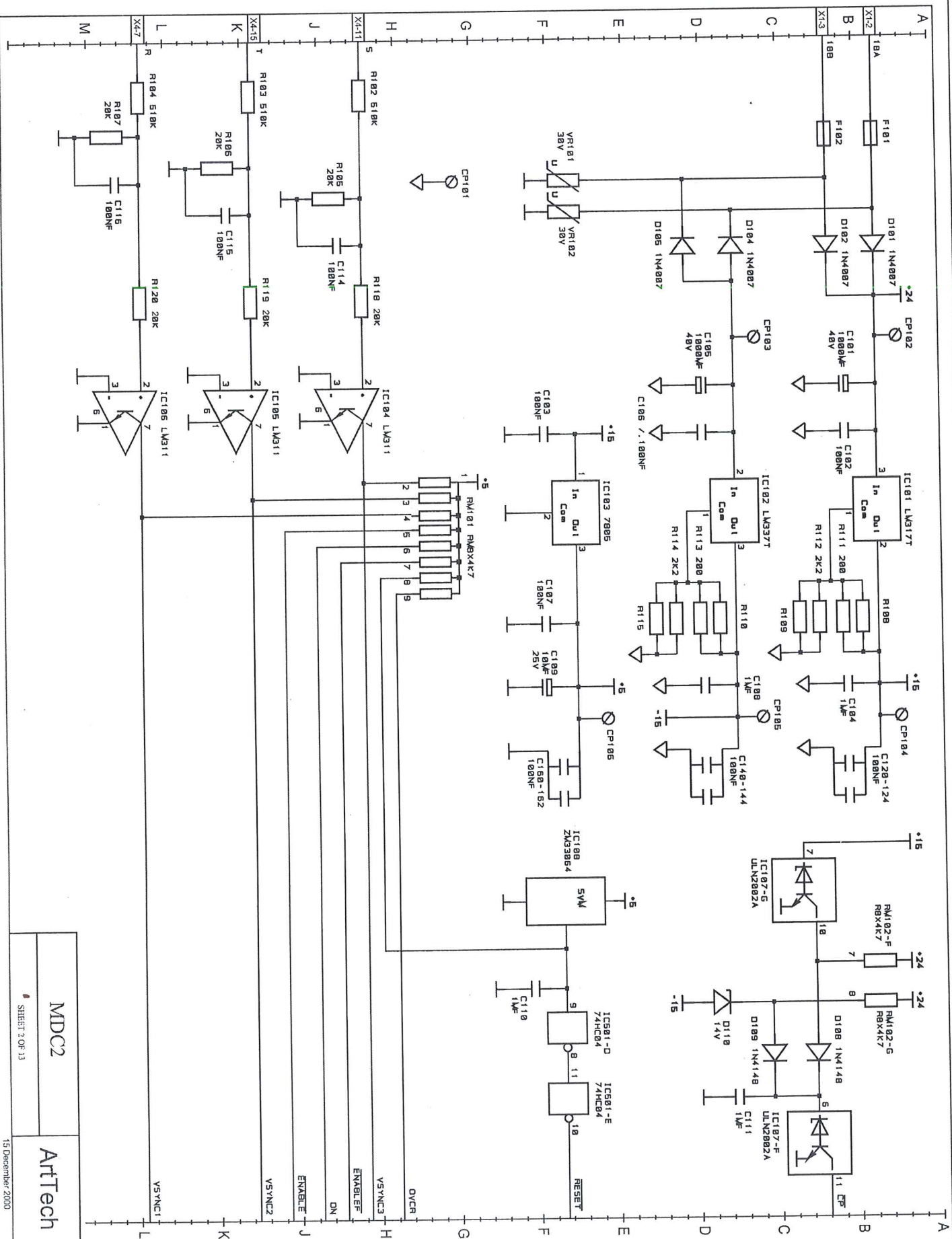

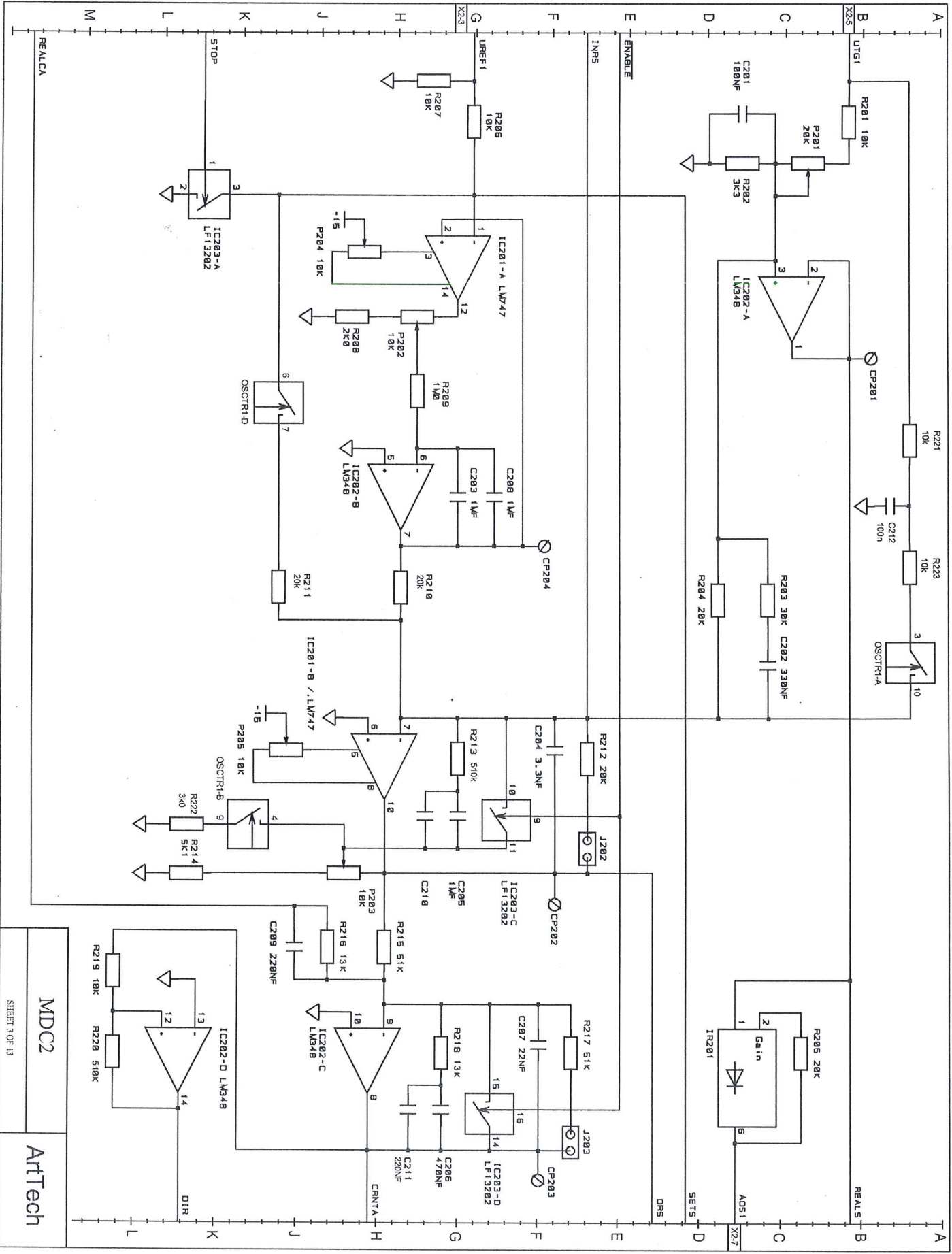

MDC2

ArtTech

SHEET 1 OF 13

15 December 2000

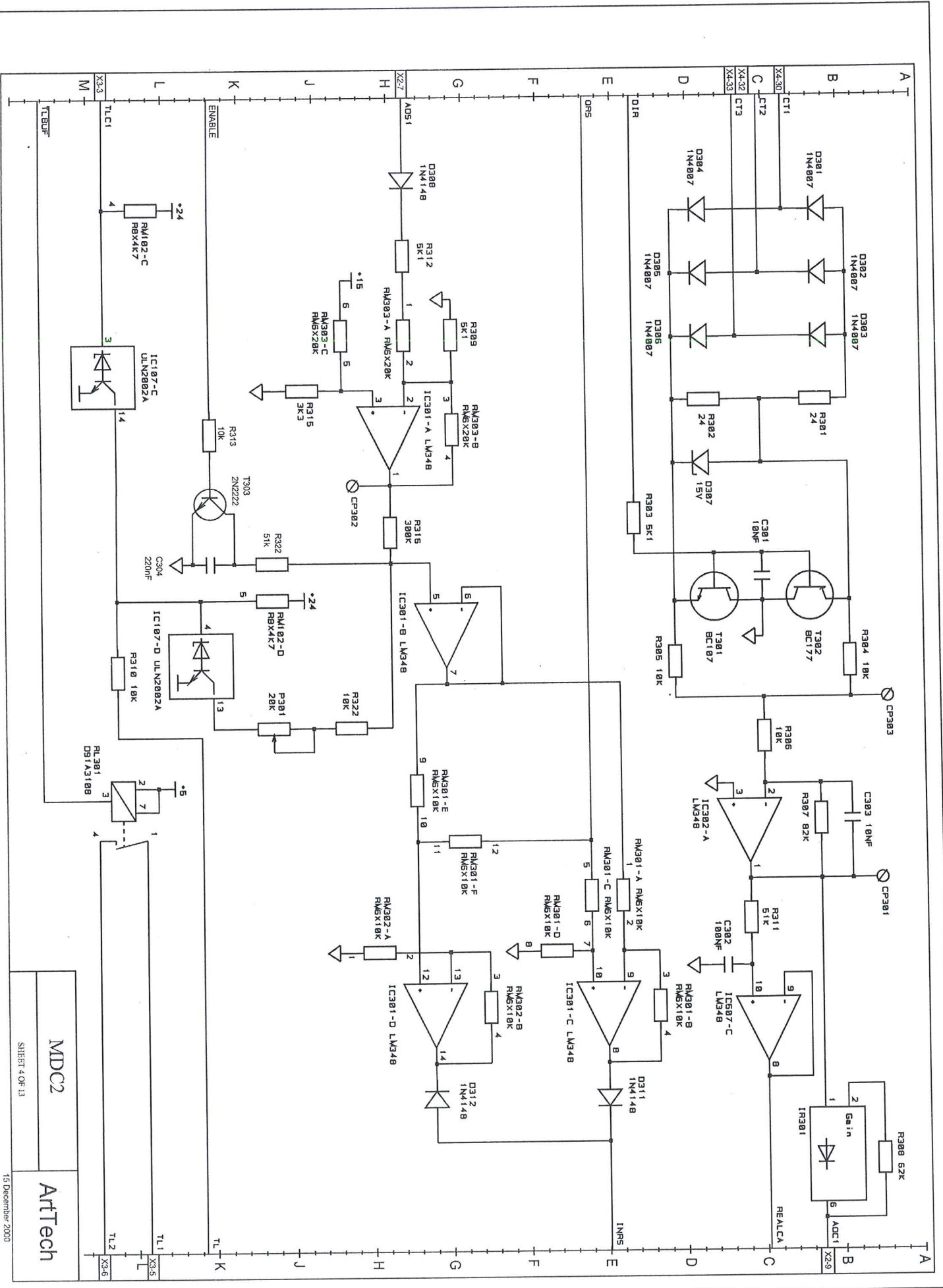

MDC2  
 SHEET 4 OF 13  
 ArtTech  
 15 December 2000



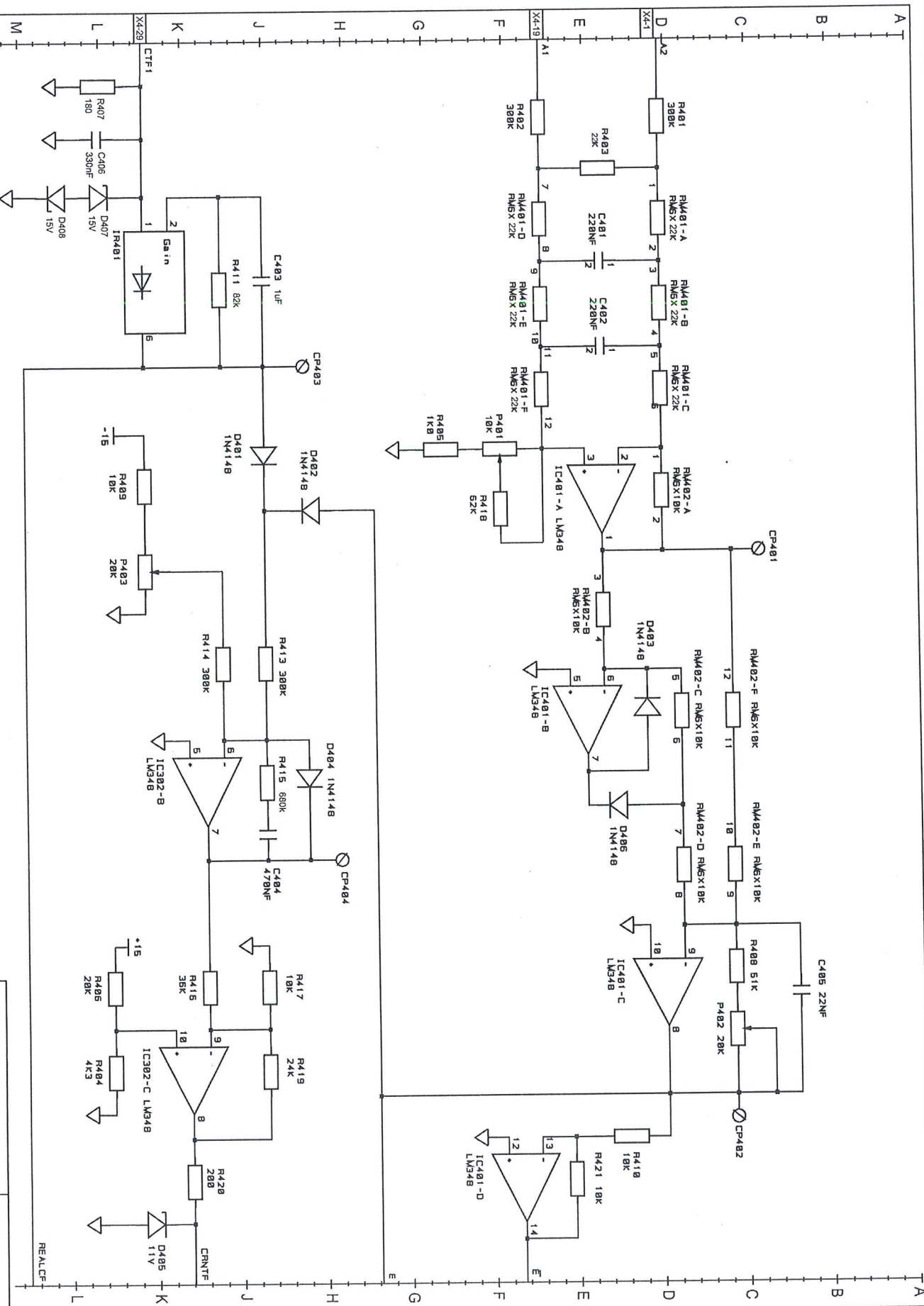

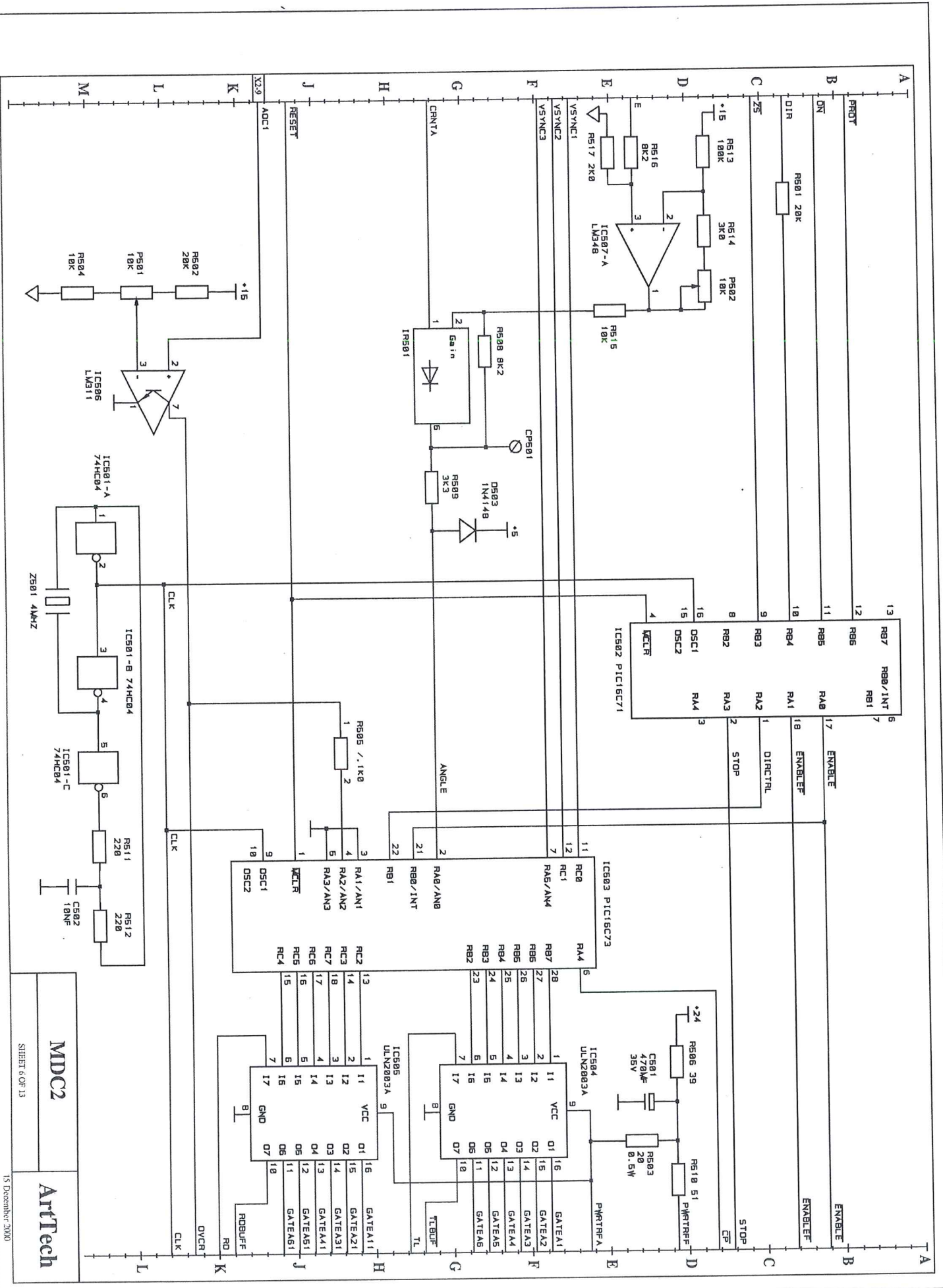

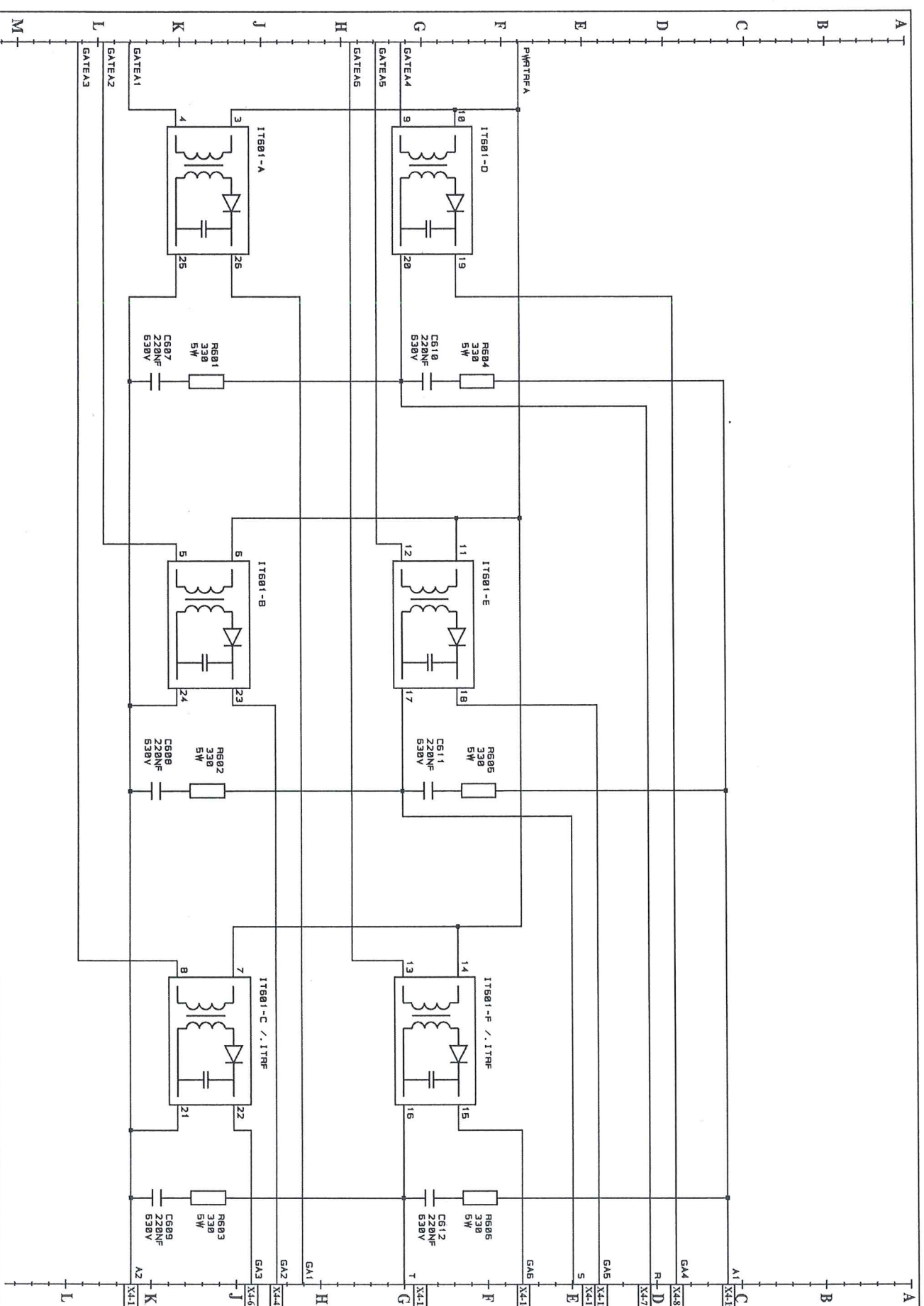

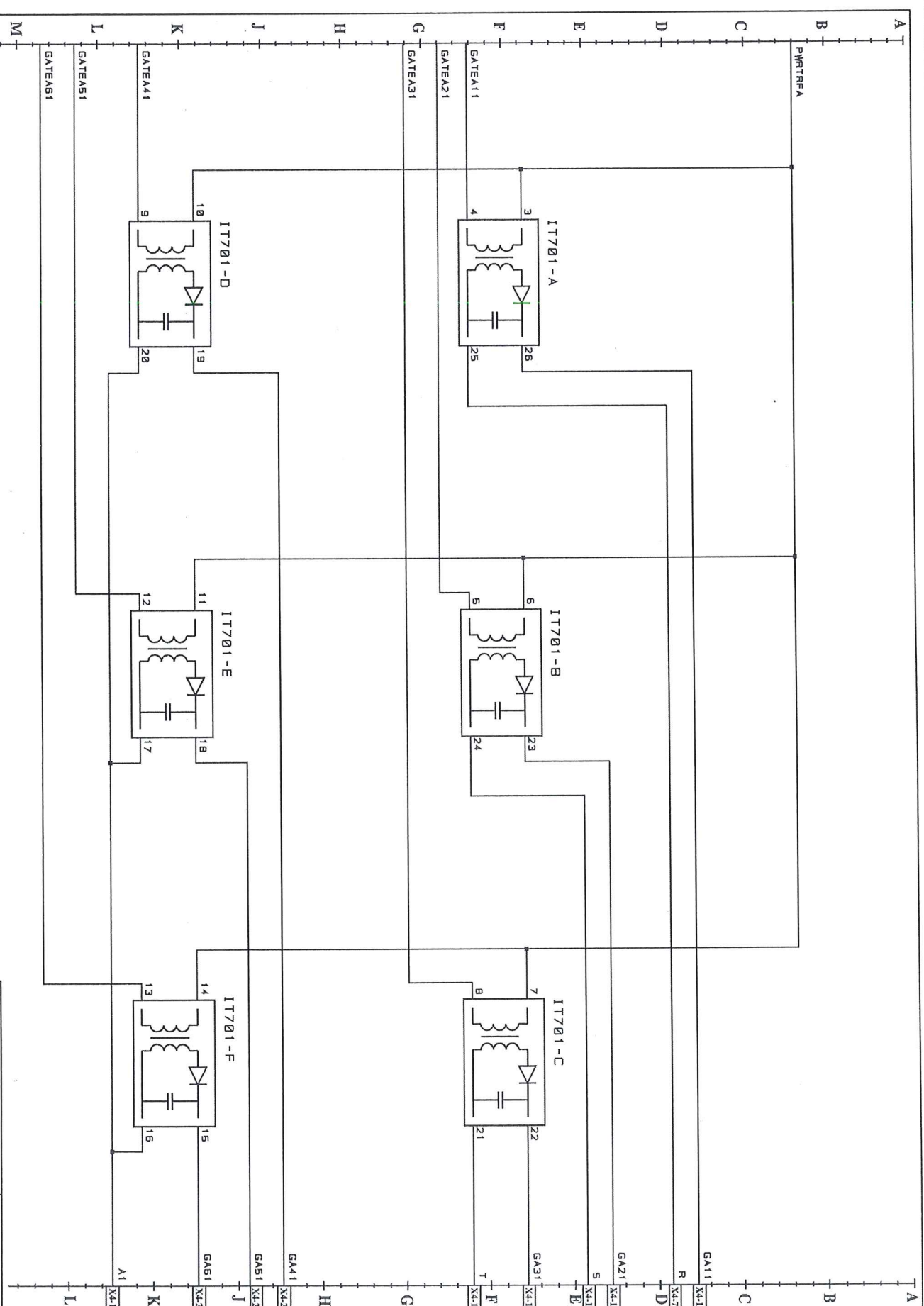





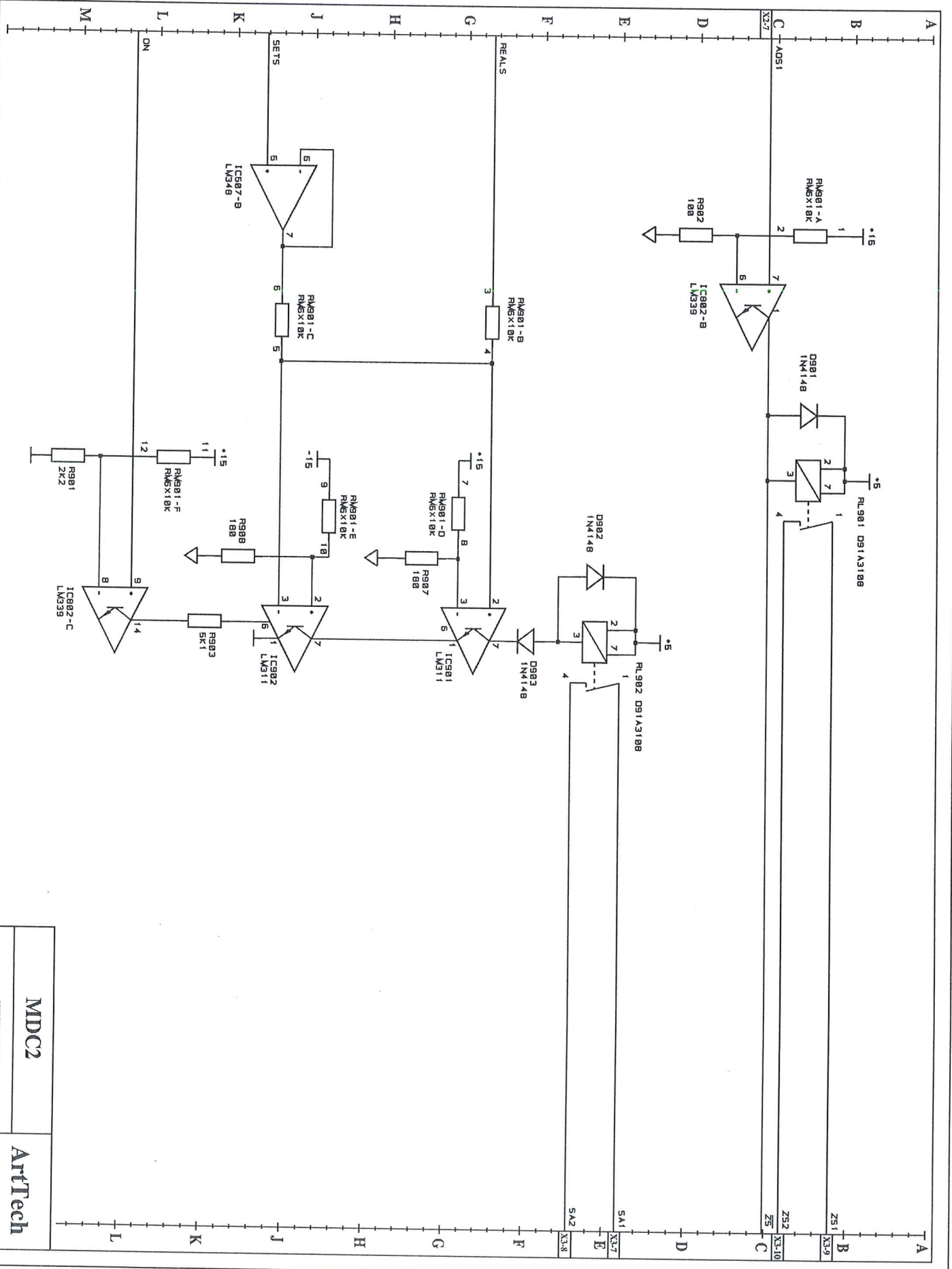

MDC2

SHEET 10 OF 13

ArtTech

15 December 2000

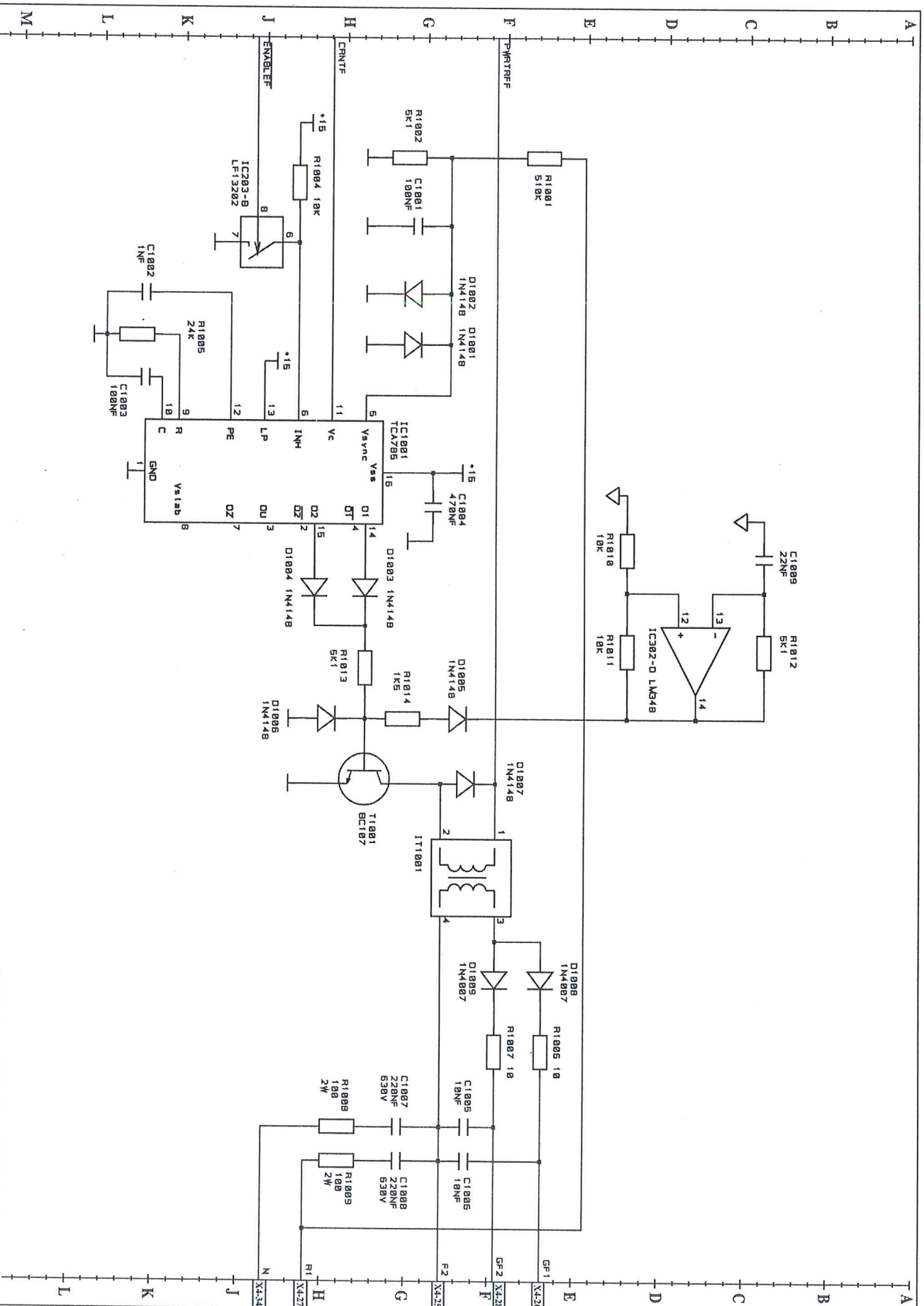



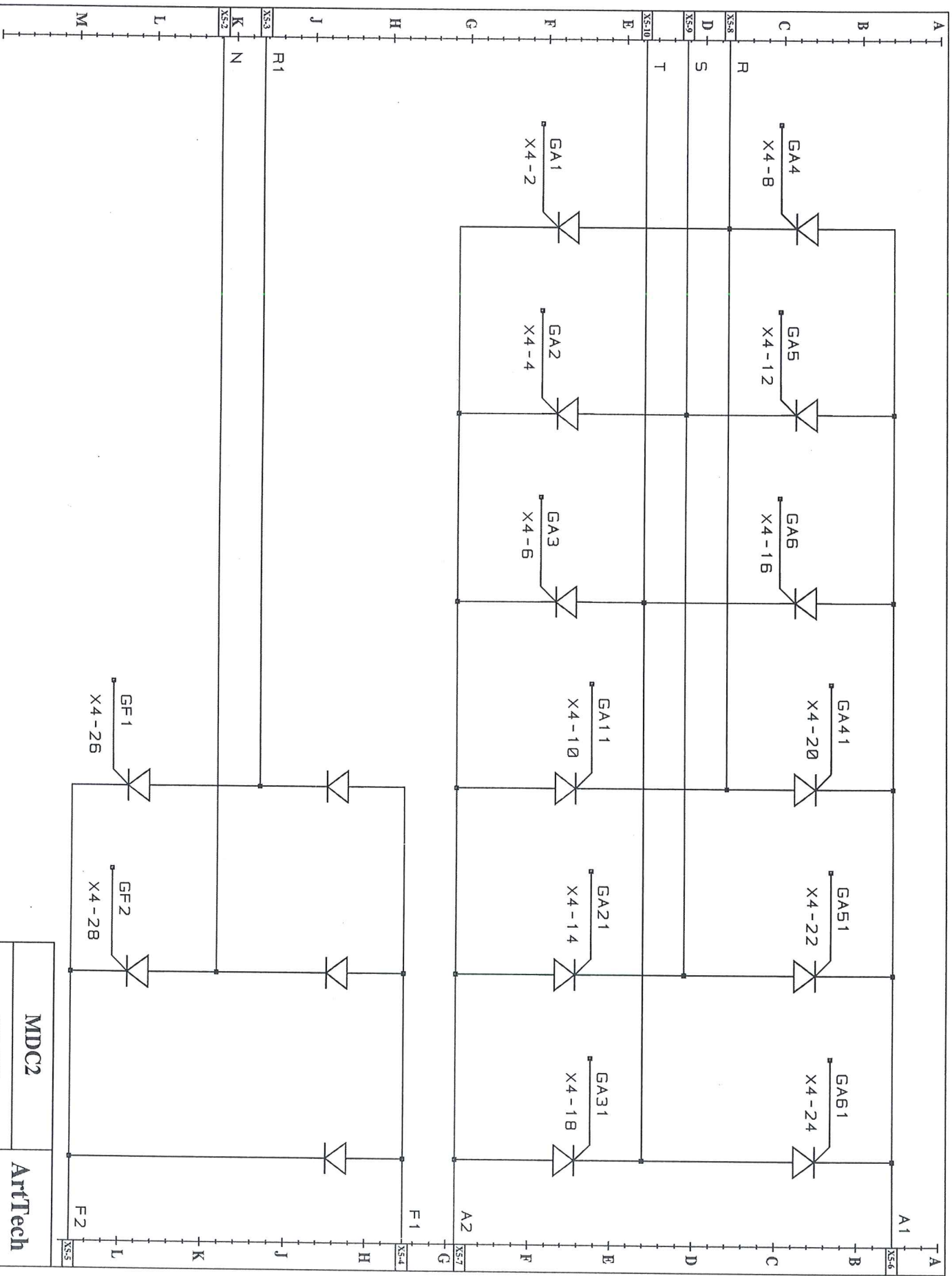

MDC2

SHEET 12 OF 13

ArtTech

15 December 2000

