

Key data

Power module using IGBT4 technology in sixpack configuration.
Isolated IGBT driver, protection and temperature sensor included.

Topology	B6I
Rated semiconductor data	1200V, 100A
Load type	Inductive, resistive
Typical applications	Industrial drives, UPS, solar inverters, auxiliary inverters
Sensors and protection	temperature, short circuit, signal transmission, UVLO for all power supplies
Interface IGBT	Electrical, 5V-CMOS, Galvanic Isolation according to IEC61800-5-1
Standards	IEC61800-5-1, UL94, RoHS



MIPAQ™ serve Internal Function Block Diagram

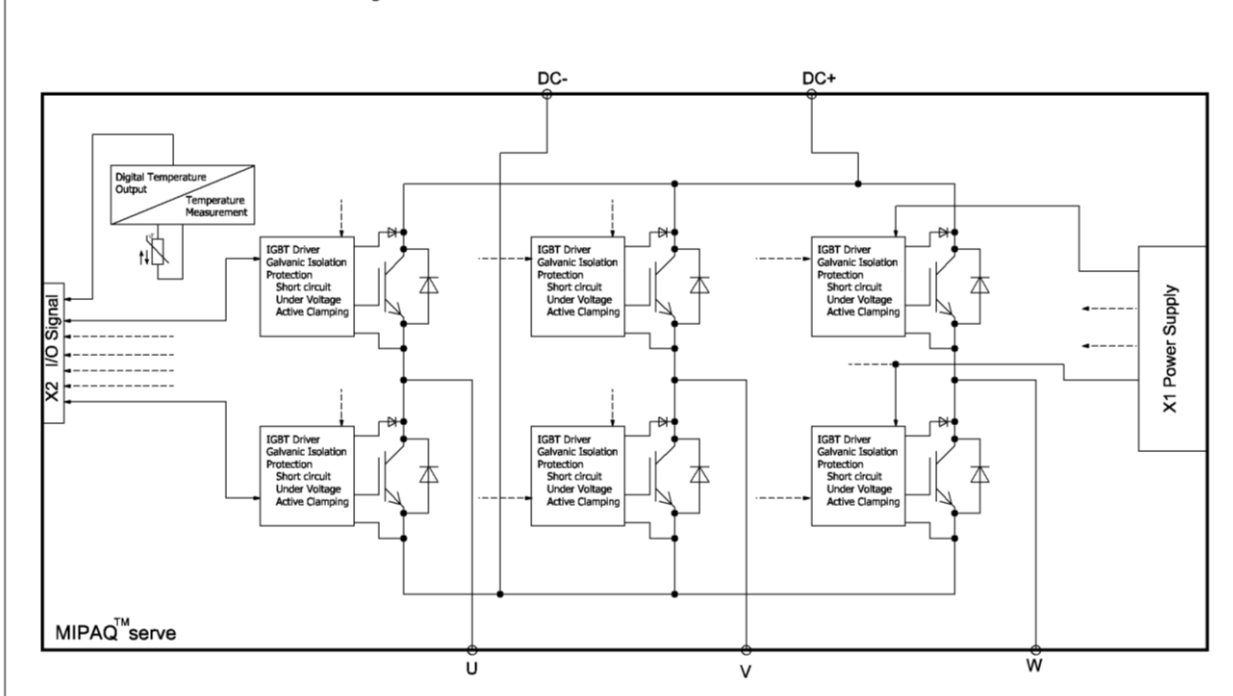

Electrical data – power part

			min	typ	max	
DC link voltage	$L_s = 30\text{nH}$ $-40 < T_{vj} < 150^\circ\text{C}$ $0 < I_{C, \text{turn off}} < 2 \cdot I_{C, \text{max}}$	U_{DC}			850	V
IGBT continuous DC collector current	$T_{\text{case}} = 100^\circ\text{C}$ $T_{vj} = T_{vj, \text{op max}}$	$I_{C, \text{nom}}$			100	A
IGBT collector-emitter voltage	$T_{vj} = 25^\circ\text{C}$	U_{CES}			1200	V
IGBT collector-emitter saturation voltage	$T_{vj} = 25^\circ\text{C} @ I_C = 100\text{A}$ $T_{vj} = 150^\circ\text{C} @ I_C = 100\text{A}$	U_{CEsat}		1,75 2,10	2,15	V
Diode repetitive peak reverse voltage	$T_{vj} = 25^\circ\text{C}$	U_{RRM}			1200	V
Diode forward voltage	$T_{vj} = 25^\circ\text{C} @ I_C = 100\text{A}$ $T_{vj} = 150^\circ\text{C} @ I_C = 100\text{A}$	U_F		1,70 1,65	2,15	V
Operating junction temperature	IGBT and Diode	$T_{vj, \text{op}}$			150	°C
Turn on energy loss per pulse	IGBT, $U_{DC} = 600\text{V}$, $I_C = 100\text{A}$ $T_{vj} = 150^\circ\text{C}$, $di/dt = 1,8\text{kA}/\mu\text{s}$	E_{on}		10,2		mJ
Turn off energy loss per pulse	IGBT, $U_{DC} = 600\text{V}$, $I_C = 100\text{A}$ $T_{vj} = 150^\circ\text{C}$, $du/dt = 3,6\text{kV}/\mu\text{s}$	E_{off}		8,0		mJ
Reverse recovery energy	Diode, $U_{DC} = 600\text{V}$, $I_F = 100\text{A}$ $T_{vj} = 150^\circ\text{C}$, $di/dt = 1,8\text{kA}/\mu\text{s}$	E_{rec}		8,0		mJ

Electrical data – control part

Auxiliary power supply: IGBT Gate (on X1)			min	typ	max	
IGBT driver positive supply	Voltage	$U_{GS P1,2,3,4}$	13	16	18	V
	Current at $f_{sw} = 20\text{kHz}$, $U_{GSP1,2,3} = +15\text{V}$, $T_{vj} = 25^\circ\text{C}$	$I_{GS P1,2,3}$			14	mA
		$I_{GS P4}$			26	mA
IGBT driver negative supply	Voltage	$U_{GS N1,2,3,4}$	-10	-8	-5	V
	Current @ $f_{sw} = 20\text{kHz}$, $U_{GSN} = -8\text{V}$, $T_{vj} = 25^\circ\text{C}$	$ I_{GS N1,2,3} $			13	mA
		$ I_{GS N4} $			18	mA
IGBT driver undervoltage lockout threshold	For each channel	U_{GS_UVLO}	10,4		12,6	V
IGBT driver undervoltage lockout hysteresis	For each channel	$U_{GS_UVLO_H}$	0,7			V

Auxiliary power supply: Logic (on X2)			min	typ	max	
Logic power supply	Voltage	U_{LS}	4,5	5	5,5	V
	Current @ $f_{sw} = 20\text{kHz}$, $U_{LS} = +5\text{V}$	I_{LS}			55	mA
Logic power supply undervoltage lockout threshold		U_{LS_UVLO}	3,5		4,3	V
Logic power supply undervoltage lockout hysteresis		$U_{LS_UVLO_H}$	0,3			V