

# DC Output Modules



Company Information

Systems Overview

Programmable Controllers

Field I/O

Software

C-more & other HMI

Drives

Soft Starters

Motors & Gearbox

Steppers/ Servos

Motor Controls

Proximity Sensors

Photo Sensors

Limit Switches

Encoders

Current Sensors

Pressure Sensors

Temperature Sensors

Pushbuttons/ Lights

Process

Relays/ Timers

Comm.

Terminal Blocks & Wiring

Power

Circuit Protection

Enclosures

Tools

Pneumatics

Safety

Appendix

Product Index

Part # Index

D4-16TD1 DC Output <--->	
<b>Outputs per Module</b>	16 (current sinking)
<b>Commons per Module</b>	2 internally connected
<b>Operating Voltage</b>	4.5-26.4VDC
<b>Output Type</b>	NPN Open collector
<b>Peak Voltage</b>	40VDC
<b>ON Voltage Drop</b>	0.5VDC @ 0.5A 0.2VDC @ 0.1A
<b>Max Current (resistive)</b>	0.5A/point - 3A/common
<b>Max Leakage Current</b>	0.1mA @ 40VDC
<b>Max Inrush Current</b>	2A for 10ms 1A for 100ms
<b>Minimum Load</b>	0.2mA
<b>Base Power Required 5V</b>	200mA max
<b>External DC Required</b>	24VDC $\pm$ 10% @ 125mA
<b>OFF to ON Response</b>	0.5ms
<b>ON to OFF Response</b>	0.5ms
<b>Terminal Type (included)</b>	Removable (D4-16IOCON)
<b>Status Indicators</b>	Logic side
<b>Weight</b>	9.5oz. (270g)
<b>Fuses</b>	1 (5A) per common Non-replaceable

D4-16TD2 DC Output <--->	
<b>Outputs per Module</b>	16 (current sourcing)
<b>Commons per Module</b>	2 (isolated)
<b>Operating Voltage</b>	10.2-26.4VDC
<b>Output Type</b>	NPN Emitter Follower
<b>Peak Voltage</b>	40VDC
<b>ON Voltage Drop</b>	1.5VDC @ 0.5A
<b>Max Current (resistive)</b>	0.5A/point 3A/common @ 50° C 2.5A/common @ 60° C
<b>Max Leakage Current</b>	0.1mA @ 40VDC
<b>Max Inrush Current</b>	2A for 10ms 1A for 100ms
<b>Minimum Load</b>	0.2mA
<b>Base Power Required 5V</b>	400mA max
<b>External DC Required</b>	None
<b>OFF to ON Response</b>	1ms
<b>ON to OFF Response</b>	1ms
<b>Terminal Type (included)</b>	Removable (D4-16IOCON)
<b>Status Indicators</b>	Logic side
<b>Weight</b>	9.8oz. (280g)
<b>Fuses</b>	1 (5A) per common Non-replaceable

See Wiring Solutions for part numbers of ZIPLink cables and connection modules compatible with this I/O module.



See Wiring Solutions for part numbers of ZIPLink cables and connection modules compatible with this I/O module.

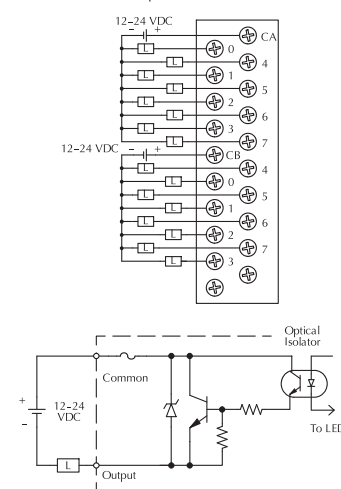
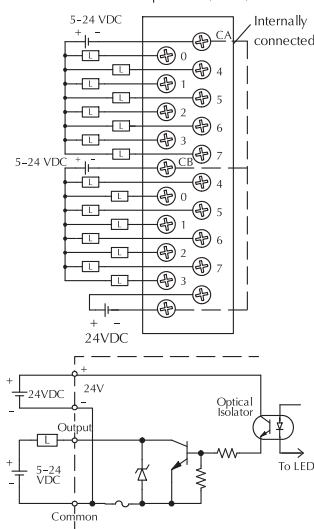
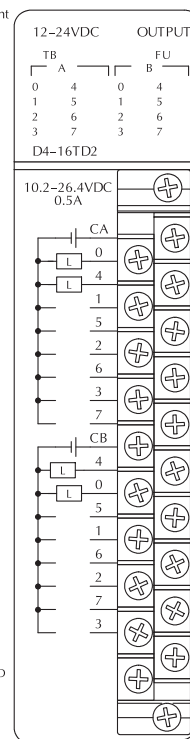
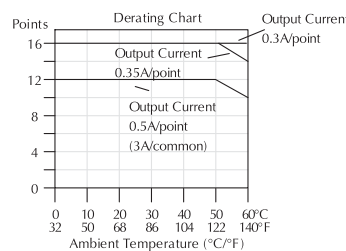
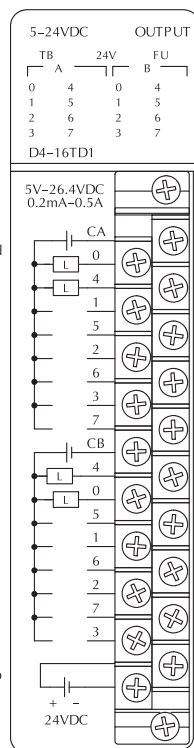
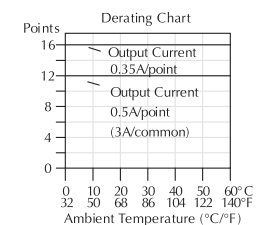

# Check the Power Budget

## Verify your power budget requirements

Your I/O configuration choice can be affected by the power requirements of the I/O modules you choose. When determining the types and quantity of I/O modules you will be using, it is important to remember there is a limited amount of power available from the power supply.

The chart on the opposite page indicates the power supplied and used by each DL405 device. The adjacent chart shows an example of how to calculate the power used by your particular system. These two charts should make it easy for you to determine if the devices you have chosen fit within the power budget of your system configuration.

If the I/O you have chosen exceeds the maximum power available from the power supply, you can resolve the problem by shifting some of the modules to an expansion base or remote I/O base (if you are using remote I/O).

**Warning:** It is extremely important to calculate the power budget correctly. If you exceed the power budget, the system may operate in an unpredictable manner which may result in a risk of personal injury or equipment damage.

## Use ZIPLinks to reduce power requirements

If your application requires a lot of relay outputs, consider using the ZipLink AC or DC relay output modules. These modules can switch high current (10A) loads without putting a load on your base power budget. Refer to Wiring System for DL405 PLCs later in this section for more information.

This logo is placed next to I/O modules that are supported by the ZIPLink connection systems.

See the I/O module specifications at the end of this section.



## Calculating your power usage

The following example shows how to calculate the power budget for the DL405 system. The example is constructed around a single 8-slot base using the devices shown. It is recommended you construct a similar table for each base in your system.

<b>A</b>			
<i>Base Number</i>	<i>Device Type</i>	<i>5 VDC (mA)</i>	<i>External 24 VDC Power (mA)</i>
<b>0</b>			
<b>B CURRENT SUPPLIED</b>			
<i>CPU/Expansion Unit /Remote Slave</i>	D4-440 CPU	3700	400
<b>C CURRENT REQUIRED</b>			
<i>SLOT 0</i>	D4-16ND2	+150	+0
<i>SLOT 1</i>	D4-16ND2	+150	+0
<i>SLOT 2</i>	F4-04DA	+120	+100
<i>SLOT 3</i>	D4-08ND3S	+100	+0
<i>SLOT 4</i>	D4-08ND3S	+100	+0
<i>SLOT 5</i>	D4-16TD2	+100	+0
<i>SLOT 6</i>	D4-16TD2	+100	+0
<i>SLOT 7</i>	D4-16TR	+1000	+0
<b>D OTHER</b>			
<i>BASE</i>	D4-08B	+80	+0
<i>Handheld Programmer</i>	D4-HPP	+320	+0
<b>E Maximum Current Required</b>		<b>2820</b>	<b>100</b>
<b>F Remaining Current Available</b>		<b>3700-2820=880</b>	<b>400-100=300</b>
1. Using a chart similar to the 3 one above, fill in column 2. 2. Using the tables on the opposite page, enter the current supplied and used by each device (columns 3 and 4). Pay special attention to the current supplied by the CPU, Expansion Unit, and Remote Slave since they differ. Devices which fall into the "Other" category (Row D) are devices such as the Base and the Handheld programmer, which also have power requirements, but do not plug directly into the base. 3. Add the current used by the system devices (columns 3 and 4) starting with Slot 0 and put the total in the row labeled "maximum current required" (Row E). 4. Subtract the row labeled "Maximum current required" (Row E), from the row labeled "Current Supplied" (Row B). Place the difference in the row labeled "Remaining Current Available" (Row F). 5. If "Maximum Current Required" is greater than "Current Supplied" in either column 3 or 4, the power budget will be exceeded. It will be unsafe to use this configuration and you will need to restructure your I/O configuration. Note the auxiliary 24 VDC power supply does not need to supply all the external power. If you need more than the 400mA supplied, you can add an external 24VDC power supply. This will help keep you within your power budget for external power.			

## DL405 CPU power supply specifications and power requirements

Specification	AC Powered Units	24 VDC Powered Units	125 VDC Powered Units
<b>Part Numbers</b>	D4-450, D4-440, D4-430, D4-EX (expansion base unit), D4-RS (remote slave unit)	D4-450DC-1, D4-440DC-1, D4-EXDC (expansion base unit), D4-RSDC (remote slave unit)	D4-450DC-2, D4-440DC-2
<b>Voltage Withstand (dielectric)</b>	1 minute @ 1,500 VAC between primary, secondary, field ground, and run relay		
<b>Insulation Resistance</b>	> 10MΩ at 500VDC		
<b>Input Voltage Range</b>	85-132 VAC (110 range) 170-264 VAC (220 range)	20-28 VDC (24 VDC) with less than 10% ripple	90-146 VDC (125 VDC) with less than 10% ripple
<b>Maximum Inrush Current</b>	20 A	20 A	20 A
<b>Maximum Power</b>	50 VA	38 W	30 W

# Power Requirements



Company Information

Systems Overview

Programmable Controllers

Field I/O

Software

C-more & other HMI

Drives

Soft Starters

Motors & Gearbox

Steppers/ Servos

Motor Controls

Proximity Sensors

Photo Sensors

Limit Switches

Encoders

Current Sensors

Pressure Sensors

Temperature Sensors

Pushbuttons/ Lights

Process

Relays/ Timers

Comm.

Terminal Blocks & Wiring

Power

Circuit Protection

Enclosures

Tools

Pneumatics

Safety

Appendix

Product Index

Part # Index

Power Supplied					
CPUs/Remote Units/ Expansion Units	5 VDC Current Supplied in mA	24V Aux Power Supplied in mA	CPUs/Remote Units/Expansion Units	5V Current Supplied in mA	24VAux. Power Supplied in mA
D4-430 CPU	3700	400	D4-EX	4000	400
D4-440 CPU	3700	400	D4-EXDC	4000	NONE
D4-440DC-1 CPU	3700	NONE	D4-EXDC-2	3700	NONE
D4-440DC-2 CPU	3700	NONE	D4-RS	3700	400
D4-450 CPU	3100	400	D4-RSDC	3700	NONE
D4-450DC-1 CPU	3100	NONE	H4-EBC	3470	400
D4-450DC-2 CPU	3100	NONE	H4-EBC-F	3300	400
Power Consumed					
Power-consuming Device	5V Current Consumed	External 24VDC Current Required	Power-consuming Device	5V Current Consumed	External 24VDC Current Required
I/O Bases			Analog Modules (continued)		
D4-04B-1	80	NONE	F4-16AD-1	75	100
D4-06B-1	80	NONE	F4-16AD-2	75	100
D4-08B-1	80	NONE	F4-04DA-1	70	75+20per circuit
<b>DC Input Modules</b>			F4-04DA-2	90	90
			F4-04DAS-1	60	60 per circuit
			F4-04DAS-2	60	60 per circuit
			F4-08DA-1	90	100+20 per circuit
			F4-08DA-2	80	150
			F4-16DA-1	90	100+20 per circuit
			F4-16DA-2	80	25 max.
			F4-08RTD	80	NONE
			F4-08THM-n	120	50
			F4-08THM	110	60
AC Input Modules			Remote I/O		
D4-08NA	100	NONE	H4-ERM	320	NONE
D4-16NA	150	NONE	H4-ERM-F	450	NONE
AC/DC Input Modules			D4-RM	300	NONE
D4-16NE3	150	NONE	Communications and Networking		
F4-08NE3S	90	NONE	H4-ECOM100	300	NONE
DC Output Modules			H4-ECOM-F	670	NONE
D4-08TD1	150	35	D4-DCM	500	NONE
F4-08TD1S	295	NONE	F4-MAS-MB	235	NONE
D4-16TD1	200	125	FA-UNICON	NONE	65
D4-16TD2	400	NONE	CoProcessors		
D4-32TD1	250	140	F4-CP128-1	305	NONE
D4-32TD1-1	250	140 (15V)	Specialty Modules		
D4-32TD2	350	120 (4A max including loads)	H4-CTRIO	400	NONE
D4-64TD1	800	NONE	D4-INT	100	NONE
AC Output Modules			D4-HSC	300	NONE
D4-08TA	250	NONE	F4-16PID	160	NONE
D4-16TA	450	NONE	F4-8MPI	225	170
Relay Output Modules			D4-16SIM	150	NONE
D4-08TR	550	NONE	F4-4LTC	280	75
F4-08TRS-1	575	NONE	Programming		
F4-08TRS	575	NONE	D4-HPP-1 (Handheld Prog.)	320	NONE
D4-16TR	1000	NONE	Operator Interface		
Analog Modules			DV-1000	150	NONE
F4-04AD	85	100	C-more Micro-Graphic	210	NONE
F4-04ADS	270	120			
F4-08AD	75	90			

## Wiring Solutions using the ZIPLink Wiring System

ZIPLinks eliminate the normally tedious process of wiring between devices by utilizing prewired cables and DIN rail mount connector modules. It's as simple as plugging in a cable connector at either end or terminating wires at only one end. Prewired cables keep installation clean and efficient, using half the space at a fraction of the cost of standard terminal blocks. There are several wiring

solutions available when using the ZIPLink System ranging from PLC I/O-to-ZIPLink Connector Modules that are ready for field termination, options for connecting to third party devices, GS, DuraPulse and SureServo Drives, and specialty relay, transorb and communications modules. Pre-printed I/O-specific adhesive label strips for quick marking of ZIPLink modules are provided with ZIPLink cables. See the following solutions to help determine the best ZIPLink system for your application.

### Solution 1: DirectLOGIC, CLICK and Productivity3000 I/O Modules to ZIPLink Connector Modules

When looking for quick and easy I/O-to-field termination, a ZIPLink connector module used in conjunction with a prewired ZIPLink cable, consisting of an I/O terminal block at one end and a multi-pin connector at the other end, is the best solution.

Using the PLC I/O Modules to ZIPLink Connector Modules selector tables located in this section,

1. Locate your I/O module/PLC.
2. Select a ZIPLink Module.
3. Select a corresponding ZIPLink Cable.



### Solution 2: DirectLOGIC, CLICK and Productivity3000 I/O Modules to 3rd Party Devices

When wanting to connect I/O to another device within close proximity of the I/O modules, no extra terminal blocks are necessary when using the ZIPLink Pigtail Cables. ZIPLink Pigtail Cables are prewired to an I/O terminal block with color-coded pigtail with soldered-tip wires on the other end.

Using the I/O Modules to 3rd Party Devices selector tables located in this section,

1. Locate your PLC I/O module.
2. Select a ZIPLink Pigtail Cable that is compatible with your 3rd party device.



### Solution 3: GS Series and DuraPulse Drives Communication Cables

Need to communicate via Modbus RTU to a drive or a network of drives?

ZIPLink cables are available in a wide range of configurations for connecting to PLCs and SureServo, SureStep, Stellar Soft Starter and AC drives. Add a ZIPLink communications module to quickly and easily set up a multi-device network.

Using the Drives Communication selector tables located in this section,

1. Locate your Drive and type of communications.
2. Select a ZIPLink cable and other associated hardware.



## Solution 4: Serial Communications Cables

ZIPLink offers communications cables for use with **Direct**LOGIC, CLICK, and Productivity3000 CPUs, that can also be used with other communications devices. Connections include a 6-pin RJ12 or 9-pin, 15-pin and 25-pin D-sub connectors which can be used in conjunction with the RJ12 or D-Sub Feedthrough modules.

Using the **Serial Communications Cables** selector table located in this section,

1. Locate your connector type
2. Select a cable.



## Solution 5: Specialty ZIPLink Modules

For additional application solutions, ZIPLink modules are available in a variety of configurations including stand-alone relays, 24VDC and 120VAC transorb modules, D-sub and RJ12 feedthrough modules, communication port adapter and distribution modules, and SureServo 50-pin I/O interface connection.

Using the **ZIPLink Specialty Modules** selector table located in this section,

1. Locate the type of application.
2. Select a ZIPLink module.



## Solution 6: ZIPLink Connector Modules to 3rd Party Devices

If you need a way to connect your device to terminal blocks without all that wiring time, then our pigtail cables with color-coded soldered-tip wires are a good solution. Used in conjunction with any compatible ZIPLink Connector Modules, a pigtail cable keeps wiring clean and easy and reduces troubleshooting time.

Using the **Universal Connector Modules and Pigtail Cables** table located in this section,

1. Select module type.
2. Select the number of pins.
3. Select cable.



# PLC I/O Modules to ZIPLink Connector Modules - DL405

DL405 PLC Input Module ZIPLink Selector				
PLC		ZIPLink		
Input Module	# of Terms	Component	Module Part No.	Cable Part No.
D4-08ND3S	20	Feedthrough	ZL-RTB20	ZL-D4-CBL20*
D4-16ND2	20	Feedthrough	ZL-RTB20	ZL-D4-CBL20*
		Sensor	ZL-LTB16-24	ZL-D4-CBL20*
D4-16ND2F	20	Feedthrough	ZL-RTB20	ZL-D4-CBL20*
		Sensor	ZL-LTB16-24	ZL-D4-CBL20*
D4-32ND3-1 <sup>2</sup>	40	Feedthrough	ZL-RTB40	ZL-D24-CBL40* ZL-D24-CBL40*X
		Sensor	ZL-LTB32-24	
D4-32ND3-2 <sup>2</sup>	40	Feedthrough	ZL-RTB40	ZL-D24-CBL40* ZL-D24-CBL40*X
		Sensor	ZL-LTB32-24	
D4-64ND2 <sup>1</sup>	40	Feedthrough	ZL-RTB40	ZL-D24-CBL40* ZL-D24-CBL40*X
		Sensor	ZL-LTB32-24	
D4-08NA <sup>3</sup>	11	See Note 3		
D4-16NA	20	Feedthrough	ZL-RTB20	ZL-D4-CBL20*
D4-16NA-1	20	Feedthrough	ZL-RTB20	ZL-D4-CBL20*
D4-16NE3	20	Feedthrough	ZL-RTB20	ZL-D4-CBL20*
		Sensor	ZL-LTB16-24	ZL-D4-CBL20*
F4-08NE3S	20	Feedthrough	ZL-RTB20	ZL-D4-CBL20*

DL405 PLC Analog Module ZIPLink Selector				
PLC		ZIPLink		
Analog Module	# of Terms	Component	Module	Cable
F4-04AD	20	Feedthrough	ZL-RTB20	ZL-D4-CBL20*
F4-04ADS	20	Feedthrough	ZL-RTB20	ZL-D4-CBL20*
F4-08AD	20	Feedthrough	ZL-RTB20	ZL-D4-CBL20*
F4-16AD-1	20	Feedthrough	ZL-RTB20	ZL-D4-CBL20*
F4-16AD-2	20	Feedthrough	ZL-RTB20	ZL-D4-CBL20*
F4-04DA-1	20	Feedthrough	ZL-RTB20	ZL-D4-CBL20*
F4-04DA-2	20	Feedthrough	ZL-RTB20	ZL-D4-CBL20*
F4-08DA-1	20	Feedthrough	ZL-RTB20	ZL-D4-CBL20*
F4-16DA-1	20	Feedthrough	ZL-RTB20	ZL-D4-CBL20*
F4-08DA-2	20	Feedthrough	ZL-RTB20	ZL-D4-CBL20*
F4-16DA-2	20	Feedthrough	ZL-RTB20	ZL-D4-CBL20*
F4-04DAS-1	20	Feedthrough	ZL-RTB20	ZL-D4-CBL20*
F4-04DAS-2	20	Feedthrough	ZL-RTB20	ZL-D4-CBL20*
F4-08THM <sup>3</sup>	T/C Wire Only	See Note 3		
F4-08THM-n <sup>3</sup>	T/C Wire Only	See Note 3		
F4-08RTD <sup>3</sup>	T/C Wire Only	See Note 3		



**NOTE: ZIPLINK CONNECTOR MODULES AND ZIPLINK CABLES SPECIFICATIONS ARE IN THE ZIPLINK CATALOG SECTION.**

DL405 PLC Output Module ZIPLink Selector				
PLC		ZIPLink		
Output Module	# of Terms	Component	Module Part No.	Cable Part No.
D4-08TD1 <sup>3</sup>	11	See Note 3		
F4-08TD1S <sup>3</sup>	20	See Note 3		
D4-16TD1	20	Feedthrough	ZL-RTB20	ZL-D4-CBL20*
		Fuse	ZL-RFU20 <sup>6</sup>	ZL-D4-CBL20*
D4-16TD2	20	Feedthrough	ZL-RTB20	ZL-D4-CBL20*
		Fuse	ZL-RFU20 <sup>6</sup>	ZL-D4-CBL20*
		Relay	ZL-RRL16-24-2	ZL-D4-CBL20*
D4-32TD1 <sup>2</sup>	40	Feedthrough	ZL-RTB40	ZL-D24-CBL40* ZL-D24-CBL40*X
		Fuse	ZL-RFU40 <sup>6</sup>	
D4-32TD1-1	40	Feedthrough	ZL-RTB40	ZL-D24-CBL40* ZL-D24-CBL40*X
		Fuse	ZL-RFU40 <sup>6</sup>	
D4-32TD2 <sup>2</sup>	40	Feedthrough	ZL-RTB40	ZL-D24-CBL40* ZL-D24-CBL40*X
		Fuse	ZL-RFU40 <sup>6</sup>	
D4-64TD1 <sup>1</sup>	40	Feedthrough	ZL-RTB40	ZL-D24-CBL40* ZL-D24-CBL40*X
		Fuse	ZL-RFU40 <sup>6</sup>	
D4-08TA <sup>3</sup>	11	See Note 3		
D4-16TA	20	Feedthrough	ZL-RTB20	ZL-D4-CBL20*
		Fuse	ZL-RFU20 <sup>6</sup>	ZL-D4-CBL20*
D4-08TR <sup>3</sup>	11	See Note 3		
F4-08TRS-1 <sup>5</sup>	20	Feedthrough	ZL-RTB20	ZL-D4-CBL20*
F4-08TRS-2 <sup>5</sup>	20	Feedthrough	ZL-RTB20	ZL-D4-CBL20*
D4-16TR <sup>4</sup>	20	Feedthrough	ZL-RTB20	ZL-D4-CBL20*
		Fuse	ZL-RFU20 <sup>6</sup>	ZL-D4-CBL20*

\* Select the cable length by replacing the \* with: Blank = 0.5m, -1 = 1.0m, or -2 = 2.0m.

<sup>1</sup> The D4-64ND2 and D4-64TD1 modules have two 32-point connectors and require two ZIPLink cables and two ZIPLink connector modules.

<sup>2</sup> To make a custom cable for the 32 or 64-point modules, use: Ribbon-style Connector ZL-D24-CON-R, Solder-style 180° connector ZL-D24-CON or Solder-style 45° connector ZL-D24-CON-X

<sup>3</sup> These modules are not supported by the ZIPLink wiring system.

<sup>4</sup> Caution: The D4-16TR relay outputs are derated not to exceed 2 Amps per point and 4 Amps per common when used with the ZIPLink wiring system.

<sup>5</sup> The F4-08TRS-1 and F4-08TRS-2 are derated not to exceed 2 Amps per point and 2 Amps per common when used with the ZIPLink wiring system.

<sup>6</sup> Note: Fuses (5 x 20 mm) are not included. See Edison Electronic Fuse section for (5 x 20 mm) fuse. S500 and GMA electronic circuit protection for fast-acting maximum protection. S506 and GMC electronic circuit protection for time-delay performance. Ideal for inductive circuits. To ensure proper operation, do not exceed the voltage and current rating of ZIPLink module. ZL-RFU20 = 2A per circuit; ZL-RFU40 = 400 mA per circuit.

