

# **TEK933 (PCI-933)**

**PENTIUM PROCESSOR  
PCI-ISA SINGLE BOARD COMPUTER  
TECHNICAL REFERENCE MANUAL  
VERSION 2.2, JUNE 1997**

**TEKNOR INDUSTRIAL COMPUTERS INC.  
616 Cure Boivin  
Boisbriand, Quebec  
J7G 2A7 CANADA**

**NOTE:**

This manual is for reference purposes only.  
Reproduction in whole or in part is authorized  
provided TEKNOR INDUSTRIAL COMPUTERS  
INC. is cited as the original source.

ref: M933S\_2-2

## **FOREWORD**

The information in this document is provided for reference purposes only. TEKNOR does not assume any liability for application of the information or use of the products described herein.

This document may contain or reference information and products protected by the copyrights or patents of others and does not convey any license under the patent right of TEKNOR, nor the rights of others.

Printed in Canada.

Copyright 1996 by TEKNOR INDUSTRIAL COMPUTER INC., Boisbriand, Qc J7G 2A7.

## TABLE OF CONTENTS

Foreword	iii
List of Diagrams	xi
List of Tables	xiii
<u>READ ME FIRST</u>	1
<u>INTRODUCTION</u>	1
<b>PART ONE</b>	
<b>QUICK INSTALLATION</b>	
1 <u>INSTALLING SYSTEM MEMORY</u>	1-1
1.01 Static Electricity Precautions	1-1
1.02 Location of SIMM Sockets	1-2
1.03 SIMM Configuration	1-3
1.04 SIMM Installation	1-6
2 <u>JUMPER LOCATIONS &amp; CONFIGURATION</u>	2-1
2.01 Jumper Locations	2-1
2.02 Jumper Settings	2-5
3 <u>INSTALLING TEK933 IN PASSIVE BACKPLANE</u>	3-1
4 <u>CONNECTOR LOCATIONS &amp; PIN-OUTS</u>	4-1
4.01 Location of Connectors on the Board	4-1
4.02 Connector Pin-Outs	4-5
5 <u>SOFTWARE SETUPS</u>	5-1
5.01 Accessing AMIBIOS Setup Program	5-1
5.02 Accessing VIP-UP Program	5-2

**PART TWO  
HARDWARE REFERENCE**

6	<u>SYSTEM</u>	6-1
6.01	Location of System Components	6-1
6.02	Microprocessor	6-8
6.03	Fan Connector	6-10
6.04	PCI/ISA System Controller	6-11
6.05	Cache	6-16
6.06	System Memory (DRAM)	6-17
6.07	BIOS (Flash EPROM & EPROM)	6-18
6.08	Battery	6-19
6.09	Supervisor Utilities	6-20
6.10	Real Time Clock - AT Keyboard & PS/2 Mouse Controller	6-21
6.11	Multi-Function Connector (Keyboard, Speaker, Reset, LED)	6-22
6.12	PS/2 Mouse Connector	6-24
7	<u>PCI-ISA BUS</u>	7-1
7.01	Location of PCI-ISA Bus Connector	7-1
7.02	PCI-ISA Connector Pin-Outs	7-2
7.03	PCI-ISA Connector Description	7-6
8	<u>SYSTEM I/O CONTROLLER</u>	8-1
8.01	Location of System I/O Controller	8-1
8.02	System I/O Controller Features	8-2
9	<u>IDE &amp; FLOPPY</u>	9-1
9.01	Installing IDE Devices	9-1
9.02	Installing Floppy Devices	9-6
10	<u>SERIAL &amp; PARALLEL PORTS</u>	10-1
10.01	Serial Ports	10-1
10.02	Parallel Port	10-8
11	<u>SCSI</u>	11-1
11.01	Installing SCSI Devices	11-1

12	<u>ETHERNET</u>	12-1
	12.01 Ethernet Features	12-1
	12.02 Setting Up Ethernet	12-1
	12.03 Ethernet Connectors	12-2
13	<u>VIDEO</u>	13-1
	13.01 Location of Video Components	13-1
	13.02 Flat Panel / CRT VGA Controller	13-3
	13.03 Connecting CRT Video Display	13-4
	13.04 Connecting Flat Panel Video Display	13-5
	13.05 Video Feature Connector (J11)	13-7
14	<u>POWER MANAGEMENT</u>	14-1
	14.01 Power Management Modes	14-1
	14.02 Reset Circuit	14-2
	14.03 Power Fail Detection Circuit	14-3
	14.04 Watchdog Timer	14-4

**PART THREE**  
**SOFTWARE REFERENCE**

15	<u>AMIBIOS SETUP</u>	15-1
15.01	Accessing AMIBIOS Setup Program	15-1
15.02	AMIBIOS Setup Main Menu	15-2
15.03	Making Selections, Saving Configurations & Exiting AMIBIOS Setup	15-3
15.04	Setup Window	15-6
15.05	Utility Window	15-24
15.06	Security Window	15-25
15.07	Default Window	15-26
16	<u>VIP-UP SETUP</u>	16-1
16.01	Accessing VIP-UP Setup Program	16-1
16.02	VIP-UP Screen	16-2
17	<u>UPDATING BIOS WITH UBIOS</u>	17-1
17.01	UBIOS - Interactive Mode	17-2
17.02	UBIOS - Batch Mode	17-7
18	<u>VT100 MODE</u>	18-1
18.01	VT100 Requirements	18-1
18.02	VT100 Setup & Configuration	18-2
18.03	Running Without a Terminal	18-4

## APPENDICES

A	<u>TEK933 SPECIFICATIONS</u>	A-1
A.01	Board Specifications	A-1
A.02	MTBF	A-2
A.03	Meeting Industry Standards	A-9
B	<u>MEMORY &amp; I/O MAPS</u>	B-1
C	<u>TEK933 BOARD DIAGRAMS</u>	C-1
D	<u>RECOMMENDED DEVICES &amp; MATING CONNECTORS</u>	D-1
E	<u>POST CODES &amp; ERROR CODES</u>	E-1
E.01	Post Codes	E-1
E.02	Word Check-Points	E-7
E.03	Beep Error Codes	E-8

## GETTING HELP

1

## LIST OF DIAGRAMS

1-1	SIMM Sockets Location	1-2
2-1	Jumper Locations With Default Settings	2-3
4-1	Connector Locations	4-3
6-1	System Components Location (Bottom of Board)	6-3
6-2	System Components Location (Top of Board)	6-5
7-1	PCI-ISA Bus Connector Location	7-1
8-1	System I/O Controller Location	8-1
9-1	IDE Connectors Location	9-2
9-2	Floppy Connector Location	9-7
9-3	Floppy Disk Cable	9-9
10-1	Serial Ports Location	10-2
10-2	Parallel Port Location	10-9
13-1	Video Components Location (Top of Board)	13-2
13-2	Video Components Location (Bottom of Board)	13-2
18-1	VT100 Full Setup	18-3
18-2	VT100 Partial Setup	18-3
B-1	Memory Map Diagram	B-1
C-1	TEK933 Assembly (Top)	C-3
C-2	TEK933 Assembly (Bottom)	C-5

## LIST OF DIAGRAMS (Continued)



C-3	TEK933 Configuration	C-7
C-5	TEK933 Mechanical Specifications	C-9
C-7	TEK933 Block Diagram	C-11

## LIST OF TABLES

1-1a	TEK933 SIMM Configurations: 2MB - 24MB	1-4
1-1b	TEK933 SIMM Configurations: 32MB - 128MB	1-5
2-1a	Jumper Settings: W1 - W6, W14 - W17	2-6
2-1b	Jumper Settings: W7-W9, W23	2-7
2-1c	Jumper Settings: W13, W18 - W22	2-8
2-1d	Jumper Settings: W24 - W27, J14	2-9
4-1	Fan Connector (J1) - Pin-Out	4-6
4-2	SCSI Interface Connector (J2) - Pin-Out	4-6
4-3	Hard Disk Connector #1 (J3) - Pin-Out	4-7
4-4	Floppy Disk Connector (J4) - Pin-Out	4-8
4-5	Multi-Function Connector - Keyboard, Speaker, Reset, LED (J5) - Pin-Out	4-9
4-6	Serial Port 1 (J6) - RS232 - Pin-Out	4-9
4-7a	Serial Port 2 (J7) - RS232 - Pin-Out	4-10
4-7b	Serial Port 2 (J7) - RS485/RS422 - Pin-Out	4-10
4-8	Hard Disk Connector #2 (J8) - Pin-Out	4-11
4-9	Flat Panel Connector (J9) - Pin-Out	4-12
4-10a	Parallel Port Connector (J10) - Standard Mode - Pin-Out	4-13
4-10b	Parallel Port Connector (J10) - EPP Mode - Pin-Out	4-14
4-10c	Parallel Port Connector (J10) - ECP Mode - Pin-Out	4-15

## LIST OF TABLES (Continued)

4-11	Video Feature Connector (J11) - Pin-Out	4-16
4-12	Optional Analog Encoder Connector (J12) - Pin-Out	4-16
4-13	PS/2 Mouse Connector (J13) - Pin-Out	4-17
4-14	Emergency BIOS Boot (J14) - Pin-Out	4-17
4-15	VGA Connector (J15) - Pin-Out	4-18
4-16	Ethernet 10 Base-T RJ45 Connector (J16) - Pin-Out	4-18
4-17	Ethernet 10 Base-2 BNC Connector (J23) - Pin-Out	4-18
6-1	Fan Connector (J1) - Pin-Out	6-10
6-2	DMA Controller Channels	6-12
6-3	8259 Interrupt Controllers Lines	6-13
6-4	Emergency BIOS Boot (J14) - Pin-Out	6-18
6-5	Register 190H, 290H or 390H	6-20
6-6	Multi-Function Connector - Keyboard, Speaker, Reset, LED - (J5) - Pin-Out	6-22
6-7	PS/2 Mouse Connector (J13) - Pin-Out	6-24
7-1a	ISA Bus Connector (A, B)	7-2
7-1b	ISA Bus Connector (C, D)	7-3
7-2a	PCI Bus Connector (A1-A30, B1-B30)	7-4
7-2b	PCI Bus Connector (A31-A62, B31-B62)	7-5

### **LIST OF TABLES (Continued)**

9-1a	Hard Disk Connector #1 (J3) - Pin-Out	9-3
------	---------------------------------------	-----

9-1b	Hard Disk Connector #2 (J8) - Pin-Out	9-4
9-2	Floppy Disk Connector (J4) - Pin-Out	9-8
10-1a	Serial Port 1 (J6) RS232 - Pin-Out	10-3
10-1b	IBM 9-Pin DSUB Standard - Pin-Out	10-3
10-2a	Serial Port 2 (J7) RS232 - Pin-Out	10-4
10-2b	IBM 9-Pin DSUB Standard - Pin-Out	10-4
10-3	Serial Port 2 (J7) RS485 - Pin-Out	10-5
10-4	Parallel Port Connector (J10) - Standard Mode	10-10
10-5	Parallel Port Connector (J10) - EPP Mode	10-11
10-6	Parallel Port Connector (J10) - ECP Mode	10-12
11-1	Common SCSI Target IDs	11-3
11-2	SCSI Connector (J2) - Pin-Out	11-4
12-1	Ethernet 10 Base-T RJ45 Connector (J16) - Pin-Out	12-2
12-2	Ethernet 10 Base-2 BNC Connector (J23) - Pin-Out	12-2
13-1	VGA Connector (J15) - Pin-Out	13-4
13-2	Flat Panel Connector (J9) - Pin-Out	13-5
13-3	Video Feature Connector (J11) - Pin-Out	13-7
<b>LIST OF TABLES (Continued)</b>		
14-1	Watchdog Timer Register	14-4
A-1	Supply Current	A-1
A-2a	Reliability Prediction (Options 1-5)	A-2

A-2b	Reliability Prediction (Options 6-10)	A-3
A-2c	Reliability Prediction (Options 11-15)	A-4
A-2d	Reliability Prediction (Options 16-20)	A-5
A-2e	Reliability Prediction (Options 21-25)	A-6
A-2f	Reliability Prediction (Options 26-30)	A-7
B-1	Memory Map	B-2
B-2	I/O Map	B-3
E-1	Beep Error Codes	E-8

## INTRODUCTION

The high performance TEK933 (also called the PCI-933) Pentium™ PCI-ISA Single Board Computer has the special characteristics of supporting Intel®'s Pentium microprocessor, as well as both the PCI bus and the ISA bus. It has the following features:

- The TEK933 fully complies with the PCI INDUSTRIAL COMPUTER MANUFACTURERS GROUP (PICMG), Revision 2.0 specification. As a result, the TEK933 is fully IBM AT compatible, as well as complying with the PCI Local Bus Specification, Revision 2.1. This board may be installed in the TEK950 PCI-ISA Passive Backplane, which has three PCI slots, five ISA slots and one dedicated PCI-ISA CPU slot (for more information, see the TEK950 TECHNICAL REFERENCE MANUAL).
- The TEK933 has an interchangeable microprocessor design, with the following Pentium™ microprocessors available: 75, 100, 120, 133, 150 and 166MHz.
- Each microprocessor has separate Code and Data Caches: 8KB Code, and 8KB Write Back Data.
- The TEK933 standard configuration also has 256KB of direct-mapped, write-back / write-through External Cache Memory (optional: none).
- System memory can be configured from 2MB to 128MB (256MB when available) of Dynamic RAM (DRAM) with 32-bit or 36-bit modules installed on the board's four vertical, 72-pin SIMM sockets.
- The board is ideal for industrial applications with features like:
  - Watchdog timer;
  - SMM (System Management Mode) support and full SMI (System Management Interrupt) interface for power management;
  - Power failure detector;
  - Low battery detector;
  - Shadow RAM BIOS support for fast execution;
  - Flash EPROM boot;
  - Real-Time Clock (RTC) with battery backup.
- The TEK933 has a multi-function connector which provides all the necessary signals for connecting the keyboard, speaker, reset, and keylock interface devices.

- The local bus SVGA video controller is from Cirrus Logic<sup>®</sup> and provides high resolution Flat Panel and CRT displays. The board also comes with 1MB of video memory (DRAM) and a Feature Connector for video overlay and color keying.
- A PS/2 mouse port is included.
- The board includes two enhanced onboard IDE interfaces, which support PIO (Programmed Input/Output) mode-4 and mode-5 transfer rates.
- The TEK933 includes an enhanced super Floppy controller which supports two Floppy disk drives of up to 2.88MB each, 16 bytes of FIFO buffering and a 48mA drive buffer.
- The TEK933 board has one parallel printer port (the hardware supports ECP and EPP modes).
- Two 16550 compatible serial ports with internal 16-byte FIFO buffers can be defined as two of the following: COM1, COM2, COM3 or COM4. Serial Port 2 is available as RS232 or RS485/RS422. Serial Port 1 is only available as RS232.
- The onboard Ethernet port, compliant with IEEE 802.3/ANSI 8802-3, can function with either the 10 Base-T or 10 Base-2 interface.
- The Ethernet Controller supports the Plug and Play standard. It has a serial EEPROM onboard for Plug and Play compatibility and configuration storage.
- An optional onboard SCSI controller supports up to seven SCSI peripherals and Fast SCSI II.

The TEK933 TECHNICAL REFERENCE MANUAL is divided as follows:

Part One - QUICK INSTALLATION - includes essential information to get your TEK933 up and running quickly:

- 1: INSTALLING SYSTEM MEMORY: How to configure and install system memory.
- 2: JUMPER LOCATIONS & CONFIGURATION: Convenient diagram and graphical tables give you an easy reference for setting jumpers.
- 3: INSTALLING TEK933 IN PASSIVE BACKPLANE: Explains which passive backplanes are compatible with the TEK933 board.
- 4: CONNECTOR LOCATIONS & PIN-OUTS: Convenient diagram and pin-out tables give you the basics for wiring in all devices and mating connectors. If you require more detail, refer to the appropriate section in Part Two - HARDWARE REFERENCE.
- 5: SOFTWARE SETUPS: This section shows you how to access the AMIBIOS Setup and the VIP-UP Setup. If you require more detail, see Section 15 - AMIBIOS SETUP and Section 16 - VIP-UP SETUP (both in Part Three - SOFTWARE REFERENCE).



Part Two - HARDWARE REFERENCE - divides the TEK933 Pentium™ PCI-ISA Single Board Computer according to functional units; it includes detailed information on the board's hardware features and on installation and setup procedures:

- 6: SYSTEM: Covers various components of the system board: Microprocessor, Fan Connector, PCI/ISA System Controller, System Cache, System Memory, EPROM BIOS devices, Battery, Supervisor Utilities, integrated Real Time Clock - AT Keyboard & PS/2 Mouse Controller, Multi-Function Connector and PS/2 Mouse Connector.
- 7: PCI-ISA BUS: Covers the PCI and ISA buses.
- 8: SYSTEM I/O: Covers the System I/O Controller.
- 9: IDE & FLOPPY: Covers IDE and Floppy connectors and related hardware and software configuration.
- 10: SERIAL & PARALLEL PORTS: Covers Serial and Parallel ports and related hardware and software configuration.
- 11: SCSI: Covers installation, configuration and termination of SCSI devices.
- 12: ETHERNET: Covers Ethernet connectors and related software configuration.
- 13: VIDEO: Covers the Video Components: Video memory, Video Controller, Flat Panel Connector, VGA Connector and Feature Connector.
- 14: POWER MANAGEMENT: Covers the System Controller's power management features, the Reset Circuit, the Power Fail Detection Circuit and the Watchdog Timer.

Part Three - SOFTWARE REFERENCE - describes in detail various software and utilities that come with the TEK933 board.

- 15:AMIBIOS SETUP: AMIBIOS software setup program is used to change operating system parameters.
- 16:VIP-UP SETUP: TEKNOR's own software setup program, which complements AMIBIOS.
- 17:UPDATING BIOS WITH UBIOS: This utility allows you to take BIOS files from a disk and update the Flash EPROM BIOS with them; it also allows you to copy the contents of the Flash BIOS to files on disk.
- 18:VT100 MODE: This feature enables the Single Board Computer to run without a local keyboard or screen: Operation is controlled by a remote terminal, or a computer emulating a terminal, via a serial link.

Following the above sections are APPENDICES A to E which comprise information you can consult when you need it. These include:

- A: TEK933 SPECIFICATIONS;
- B: MEMORY & I/O MAPS;
- C: TEK933 BOARD DIAGRAMS;
- D: RECOMMENDED DEVICES  
& MATING CONNECTORS;
- E: POST CODES & ERROR CODES.

These appendices are followed by a GETTING HELP section which includes Technical Support information, the warranty and instructions on returning merchandise.

**PART ONE**  
**QUICK INSTALLATION**

- 1 INSTALLING SYSTEM MEMORY
- 2 JUMPER LOCATIONS & CONFIGURATION
- 3 INSTALLING TEK933 IN PASSIVE BACKPLANE
- 4 CONNECTOR LOCATIONS & PIN-OUTS
- 5 SOFTWARE SETUPS

## **1 INSTALLING SYSTEM MEMORY**

Dynamic Random Access Memory (DRAM) is essential system memory. It can be configured from 2MB to 128MB (256MB when available) using 32-bit or 36-bit SIMMs (Single In-line Memory Modules). This is the only type of memory which can be installed by the user.

### **1.01 STATIC ELECTRICITY PRECAUTIONS**

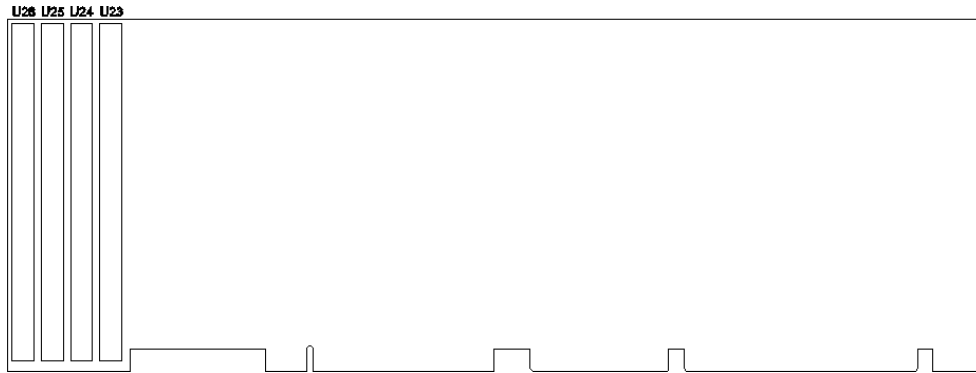
Since static electricity can damage a board, the following precautions should be taken whenever you handle the TEK933:

- Keep the board in its antistatic package, until you are ready to install it.
- Touch a grounded surface before removing the board from its package or wear a grounding wrist strap; this will discharge any static electricity that may have built up in your body.
- Handle the board by the edges.
- When handling the board, touch a grounded surface often or wear a grounding wrist strap.

## 1.02 LOCATION OF SIMM SOCKETS

The location of the four 72-pin vertical SIMM sockets appears on Diagram 1-1; these sockets are labeled U23, U24, U25 and U26.

**DIAGRAM 1-1:** SIMM Sockets Location



### 1.03 SIMM CONFIGURATION

At least 2MB of system memory must be installed on the TEK933 for proper operation.

Each of the 72-pin vertical SIMM sockets on the board can accept the following 32-bit or 36-bit modules:

- 256K x 32-bit / 36-bit = 1MB module,
- 512K x 32-bit / 36-bit = 2MB module,
- 1M x 32-bit / 36-bit = 4MB module,
- 2M x 32-bit / 36-bit = 8MB module,
- 4M x 32-bit / 36-bit = 16MB module,
- 8M x 32-bit / 36-bit = 32MB module, and
- 16M x 32-bit / 36-bit = 64MB module (not available yet).

SIMM modules must be installed in either two or four sockets:

- In U23 and U24, or
- In U25 and U26, or
- In U23, U24, U25 and U26.

SIMMs installed in U23 and U24 must be of the same capacity; likewise, U25 and U26 must be of the same capacity (however, SIMMs in U23-U24 may be of a different capacity than those in U25-U26).

Consult the tables on the following pages to see which SIMM configurations are supported by the TEK933.

DRAM devices with fast page mode at 70ns maximum access time are recommended. Please refer to Appendix D for a list of recommended devices.

**TABLE 1-1a: TEK933 SIMM Configurations: 2MB - 24MB**

TOTAL SYSTEM MEMORY	U23	U24	U25	U26
2MB	1MB (256Kx36)	1MB (256Kx36)	--	--
2MB	--	--	1MB (256Kx36)	1MB (256Kx36)
4MB	1MB (256Kx36)	1MB (256Kx36)	1MB (256Kx36)	1MB (256Kx36)
4MB	2MB (512Kx36)	2MB (512Kx36)	--	--
4MB	--	--	2MB (512Kx36)	2MB (512Kx36)
6MB	2MB (512Kx36)	2MB (512Kx36)	1MB (256Kx36)	1MB (256Kx36)
6MB	1MB (256Kx36)	1MB (256Kx36)	2MB (512Kx36)	2MB (512Kx36)
8MB	2MB (512Kx36)	2MB (512Kx36)	2MB (512Kx36)	2MB (512Kx36)
8MB	4MB (1Mx36)	4MB (1Mx36)	--	--
8MB	--	--	4MB (1Mx36)	4MB (1Mx36)
10MB	4MB (1Mx36)	4MB (1Mx36)	1MB (256Kx36)	1MB (256Kx36)
10MB	1MB (256Kx36)	1MB (256Kx36)	4MB (1Mx36)	4MB (1Mx36)
12MB	4MB (1Mx36)	4MB (1Mx36)	2MB (512Kx36)	2MB (512Kx36)
12MB	2MB (512Kx36)	2MB (512Kx36)	4MB (1Mx36)	4MB (1Mx36)
16MB	4MB (1Mx36)	4MB (1Mx36)	4MB (1Mx36)	4MB (1Mx36)
16MB	8MB (2Mx36)	8MB (2Mx36)	--	--
16MB	--	--	8MB (2Mx36)	8MB (2Mx36)
18MB	8MB (2Mx36)	8MB (2Mx36)	1MB (256Kx36)	1MB (256Kx36)
18MB	1MB (256Kx36)	1MB (256Kx36)	8MB (2Mx36)	8MB (2Mx36)
20MB	8MB (2Mx36)	8MB (2Mx36)	2MB (512Kx36)	2MB (512Kx36)
20MB	2MB (512Kx36)	2MB (512Kx36)	8MB (2Mx36)	8MB (2Mx36)
24MB	8MB (2Mx36)	8MB (2Mx36)	4MB (1Mx36)	4MB (1Mx36)
24MB	4MB (1Mx36)	4MB (1Mx36)	8MB (2Mx36)	8MB (2Mx36)

**Note:** 36-bit modules are shown, however 32-bit modules are supported.



**TABLE 1-1b: TEK933 SIMM Configurations: 32MB - 128MB**

TOTAL SYSTEM MEMORY	U23	U24	U25	U26
32MB	8MB (2Mx36)	8MB (2Mx36)	8MB (2Mx36)	8MB (2Mx36)
32MB	16MB (4Mx36)	16MB (4Mx36)	--	--
32MB	--	--	16MB (4Mx36)	16MB (4Mx36)
34MB	16MB (4Mx36)	16MB (4Mx36)	1MB (256Kx36)	1MB (256Kx36)
34MB	1MB (256Kx36)	1MB (256Kx36)	16MB (4Mx36)	16MB (4Mx36)
36MB	16MB (4Mx36)	16MB (4Mx36)	2MB (512Kx36)	2MB (512Kx36)
36MB	2MB (512Kx36)	2MB (512Kx36)	16MB (4Mx36)	16MB (4Mx36)
40MB	16MB (4Mx36)	16MB (4Mx36)	4MB (1Mx36)	4MB (1Mx36)
40MB	4MB (1Mx36)	4MB (1Mx36)	16MB (4Mx36)	16MB (4Mx36)
48MB	16MB (4Mx36)	16MB (4Mx36)	8MB (2Mx36)	8MB (2Mx36)
48MB	8MB (2Mx36)	8MB (2Mx36)	16MB (4Mx36)	16MB (4Mx36)
64MB	16MB (4Mx36)	16MB (4Mx36)	16MB (4Mx36)	16MB (4Mx36)
64MB	32MB (8Mx36)	32MB (8Mx36)	--	--
64MB	--	--	32MB (8Mx36)	32MB (8Mx36)
66MB	32MB (8Mx36)	32MB (8Mx36)	1MB (256Kx36)	1MB (256Kx36)
66MB	1MB (256Kx36)	1MB (256Kx36)	32MB (8Mx36)	32MB (8Mx36)
68MB	32MB (8Mx36)	32MB (8Mx36)	2MB (512Kx36)	2MB (512Kx36)
68MB	2MB (512Kx36)	2MB (512Kx36)	32MB (8Mx36)	32MB (8Mx36)
72MB	32MB (8Mx36)	32MB (8Mx36)	4MB (1Mx36)	4MB (1Mx36)
72MB	4MB (1Mx36)	4MB (1Mx36)	32MB (8Mx36)	32MB (8Mx36)
80MB	32MB (8Mx36)	32MB (8Mx36)	8MB (2Mx36)	8MB (2Mx36)
80MB	8MB (2Mx36)	8MB (2Mx36)	32MB (8Mx36)	32MB (8Mx36)
96MB	32MB (8Mx36)	32MB (8Mx36)	16MB (4Mx36)	16MB (4Mx36)
96MB	16MB (4Mx36)	16MB (4Mx36)	32MB (8Mx36)	32MB (8Mx36)
128MB	32MB (8Mx36)	32MB (8Mx36)	32MB (8Mx36)	32MB (8Mx36)

**Note:** 36-bit modules are shown, however 32-bit modules are supported.

#### **1.04 SIMM INSTALLATION**

When you are ready to install the SIMMs in the sockets, follow the steps outlined below.

- With the board flat on the table, turn it so that the sockets are at the end of the board farthest from you.
- Hold the module with the notch on the bottom right facing you, and insert the connector into the socket at a 70° angle from the board.
- Snap the module to a vertical position in the socket. The module is fully inserted when the retaining pegs snap into the holes at each end of the module.

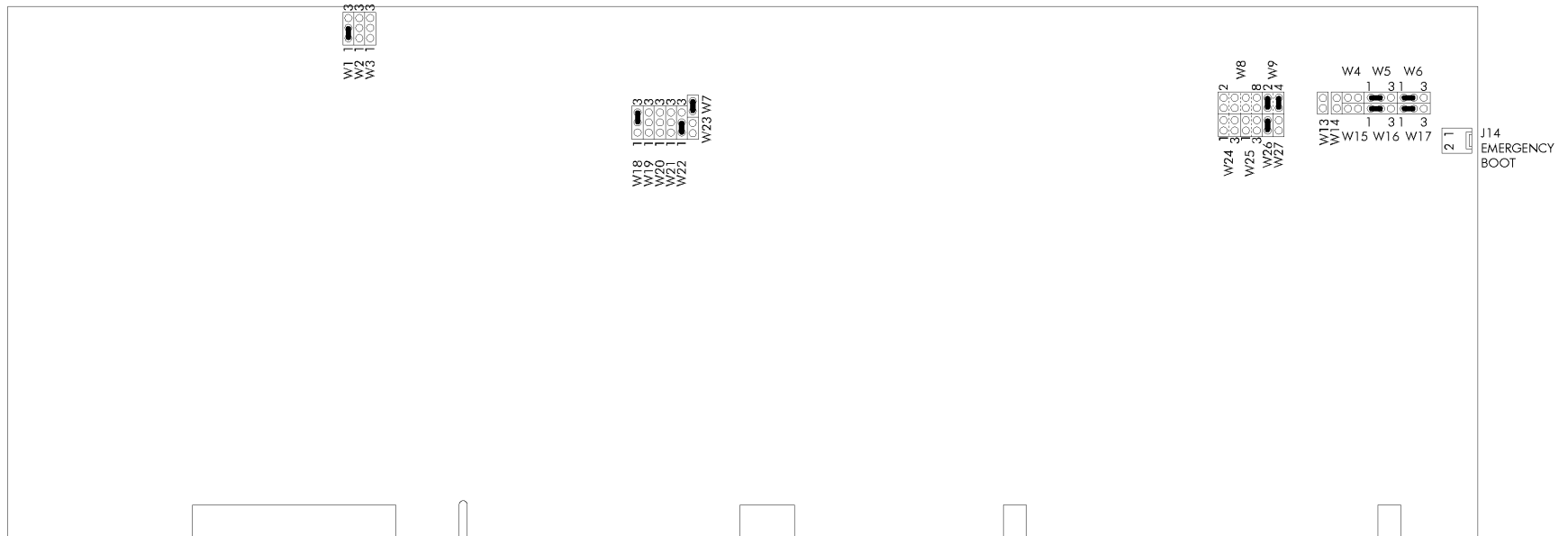
## **2 JUMPER LOCATIONS & CONFIGURATION**

### **2.01 JUMPER LOCATIONS**

Diagram 2-1 and the tables on the following pages show the TEK933 jumpers and their initial setting. These jumpers are labeled from W1 to W9, W13 to W27, and J14. The jumpers appear as rectangular boxes containing small numbers which represent the pin numbers.

**DIAGRAM 2-1: Jumper Locations With Default Settings**

**Note that W2, W3, W19, W20 and W21 are CPU dependent: See Jumper Settings Tables.**



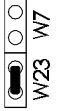
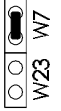
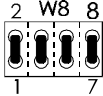
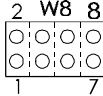

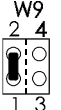
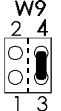
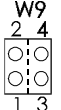
## **2.02 JUMPER SETTINGS**

Table 2-1a to 2-1d on the following pages show all the possible jumper settings for W1 to W9, W13 to W27, and J14.



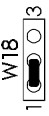


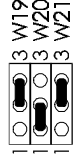
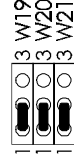
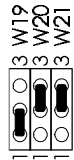


**TABLE 2-1a: Jumper Settings: W1-W6, W14-W17**

NAME	FUNCTION	CONFIGURATION (INITIAL SETTING: *)
W1	First-Level Cache: Write-Back or Write-Through	<span style="margin-left: 100px;">Write-back *</span> <span style="margin-left: 100px;">Write-through</span>
W2 W3	Multiplier for Pentium Internal CPU Clock Speed	<span style="margin-left: 20px;">1.5X for: 75MHz (50MHz Bus Clock) 90MHz (60MHz Bus Clock) 100MHz (66MHz Bus Clock)</span>  <span style="margin-left: 20px;">2X for: 120MHz (60MHz Bus Clock) 133MHz (66MHz Bus Clock)</span>  <span style="margin-left: 20px;">2.5X for: 150MHz (60MHz Bus Clock) 166MHz (66MHz Bus Clock)</span>  <span style="margin-left: 20px;">3X Reserved for future use</span>
W4 W15	RTS2-CTS2 Serial Port 2 RS485/RS422 Loopback DSR2-DTR2 Serial Port 2 RS485/RS422 Loopback	<span style="margin-left: 100px;">Loopback</span> <span style="margin-left: 100px;">Normal *</span>
W5 W6 W14 W16 W17	Serial Port 2 Configuration	<p>RS232 *</p> <p>RS485/RS422</p>

**TABLE 2-1b: Jumper Settings: W7-W9, W23**













NAME	FUNCTION	CONFIGURATION (INITIAL SETTING: * )
W7 W23	Feature Connector & Video Standby	 <p>Feature Connector Enabled &amp; Video Standby Disabled</p>  <p>Feature Connector Disabled &amp; Video Standby Enabled *</p>
W8	Extended BIOS Modes (These jumpers are configured separately, even though they are grouped together here)	<p>1-2: Reserved 3-4: VT100 Mode 5-6: Disable TEKNOR Extension * 7-8: Disable Onboard VGA Controller</p>  <p>1-2: Reserved * 3-4: Standard Mode * 5-6: Enable TEKNOR Extension 7-8: Enable Onboard VGA Controller *</p> 
W9	Supervisor I/O: Base address	 <p>190H *</p>  <p>290H</p>  <p>390H</p>  <p>390H</p>

**TABLE 2-1c: Jumper Settings: W13, W18-W22**

NAME	FUNCTION	CONFIGURATION (INITIAL SETTING: *)
W13	Non Maskable Interrupt on Power Fail Output	 Enabled  Disabled *
W18	SCSI Termination	 Controlled by software  Disabled by hardware  Controlled by hardware (board is terminated) *
W19 W20 W21	CPU / Bus Clock	 50MHz  60MHz  66MHz
W22	Panel Shift Clock	 Normal *  Inverse



**TABLE 2-1d: Jumper Settings: W24-W27, J14**

NAME	FUNCTION	CONFIGURATION (INITIAL SETTING: *)
W24 & W25	2.88 MB High Density Floppy, EDOUT signal  2.88 MB High Density Floppy, HDOUT signal	<p>EDOUT left to software*      OR: 1-3: EDOUT to Pin 29 (J4);      OR: 1-2: EDOUT to Pin 17 (J4);</p> <p>2-4: Ground to Pin 17 (J4)      3-4: Ground to Pin 29 (J4)</p>    <p>HDOUT left to software*      1-3: HDOUT to Pin 33 (J4);      1-2: HDOUT to Pin 27 (J4);</p> <p>2-4: Ground to Pin 27 (J4)      3-4: Ground to Pin 33 (J4)</p>   
W26	Watchdog Timer	 W26 Enabled *  W26 Disabled
W27	VBAT Internal Battery	 W27 Enabled  W27 Disabled *
J14	BIOS boot selection	 J14 Emergency boot (from EPROM BIOS)  J14 Normal boot (from Flash EPROM BIOS) *

### **3 INSTALLING TEK933 IN PASSIVE BACKPLANE**

The TEK933 will work on any PCI-ISA passive backplane, provided it complies with the PCI INDUSTRIAL COMPUTER MANUFACTURERS GROUP, Revision 2.0 specification. Therefore, the board may be installed on the TEK950 PCI-ISA Passive Backplane, which has three PCI slots, five ISA slots, and a PCI-ISA connector where you can insert the TEK933 (for more information, see the TEK950 TECHNICAL REFERENCE MANUAL).

Since the TEK933 is also fully IBM AT compatible, it can also be installed on any standard ISA passive backplane, if PCI expansion slots are not needed.

Note: The TEK933 chipset does not support address stepping (described in the PCI Local Bus Specification). To ensure proper detection of PCI adapter cards, resistors of  $33\Omega$  or less should be used on the backplane's ID SELECT signal address lines (between the CPU slot and each PCI slot). All TEKNOR PCI backplanes include this specific feature. For more information, contact TEKNOR's Technical Support department.

## **4 CONNECTOR LOCATIONS & PIN-OUTS**

### **4.01 LOCATION OF CONNECTORS ON THE BOARD**

The connectors are labeled J1 to J16 and J23. They appear on the diagram on the following page.



## 4.02 CONNECTOR PIN-OUTS

Consult the tables on the following pages for the J1 to J16 and J23 connector pin-outs. This information will help you wire all devices and mating connectors to the TEK933 board. For additional information, consult the appropriate section:

<u>Connector</u>	<u>Section which deals with it</u>
J1 - Fan	6 SYSTEM
J2 - SCSI	11 SCSI
J3 - Hard Disk Connector #1	9 IDE & FLOPPY
J4 - Floppy Disk Connector	9 IDE & FLOPPY
J5 - Multi-Function (Keyboard, Speaker, Reset, LED)	6 SYSTEM
J6 - Serial Port 1	10 SERIAL & PARALLEL PORTS
J7 - Serial Port 2	10 SERIAL & PARALLEL PORTS
J8 - Hard Disk Connector #2	9 IDE & FLOPPY
J9 - Flat Panel	13 VIDEO
J10 - Parallel Port	10 SERIAL & PARALLEL PORTS
J11 - Feature Connector	13 VIDEO
J12 - Reserved for Optional Analog Encoder Connector	
J13 - PS/2 Mouse	6 SYSTEM
J14 - Emergency BIOS Boot Selection	6 SYSTEM
J15 - VGA	13 VIDEO
J16 - Ethernet (10 BASE-T)	12 ETHERNET
J23 - Ethernet (10 BASE-2)	12 ETHERNET

**TABLE 4-1: Fan Connector (J1) - Pin-Out**

Pin Number	Signal
1	+12V
2	GND

**TABLE 4-2: SCSI Interface Connector (J2) - Pin-Out**

Pin Number	Signal	Pin Number	Signal
1	GND	2	SCSI D0
3	GND	4	SCSI D1
5	GND	6	SCSI D2
7	GND	8	SCSI D3
9	GND	10	SCSI D4
11	GND	12	SCSI D5
13	GND	14	SCSI D6
15	GND	16	SCSI D7
17	GND	18	SCSI DP*
19	GND	20	GND
21	GND	22	GND
23	GND	24	GND
25	Not Used	26	Term Power
27	GND	28	GND
29	GND	30	GND
31	GND	32	ATN*
33	GND	34	GND
35	GND	36	BSY*
37	GND	38	ACK*
39	GND	40	RESET*
41	GND	42	MSG*
43	GND	44	SEL*
45	GND	46	C/D*
47	GND	48	REQ*
49	GND	50	I/O*

\* Active low signal

**TABLE 4-3: Hard Disk Connector #1 (J3) - Pin-Out**

Pin Number	Signal Flow	Signal	Pin Number	Signal Flow	Signal
1	I	RESET*	2	-	GND
3	I/O	SD7	4	I/O	SD8
5	I/O	SD6	6	I/O	SD9
7	I/O	SD5	8	I/O	SD10
9	I/O	SD4	10	I/O	SD11
11	I/O	SD3	12	I/O	SD12
13	I/O	SD2	14	I/O	SD13
15	I/O	SD1	16	I/O	SD14
17	I/O	SD0	18	I/O	SD15
19	-	GND	20	-	Not Used
21	O	REQ A	22	-	GND
23	I	IOW*	24	-	GND
25	I	IOR*	26	-	GND
27	O	IOCHRDY	28	-	Not Used
29	O	DACK A*	30	-	GND
31	O	IRQ14	32	O	IOCS16*
33	I	SA1	34	-	Not Used
35	I	SA0	36	I	SA2
37	I	CS0 A*	38	I	CS1 A*
39	O	ACTIVE*	40	-	GND

\* Active low signal

**TABLE 4-4:** Floppy Disk Connector (J4) - Pin-Out

Pin Number	Signal Flow	Signal	Pin Number	Signal Flow	Signal
1	-	GND	2	O	RPM/LC
3	-	GND	4	-	Not Used
5	-	GND	6	-	Not Used
7	-	GND	8	I	INDEX*
9	-	GND	10	O	MOTOR ON 0,1*
11	-	GND	12	O	DRIVE SELECT B
13	-	GND	14	O	DRIVE SELECT A
15	-	GND	16	O	MOTOR ON 2*
17	-	N. C. <sup>1</sup>	18	O	DIR CONTROL
19	-	GND	20	O	STEP*
21	-	GND	22	O	WRITE DATA*
23	-	GND	24	O	WRITE ENABLE*
25	-	GND	26	I	TRACK0*
27	-	N. C. <sup>1</sup>	28	I	WRITE PROTECT*
29	-	N. C. <sup>1</sup>	30	I	READ DATA*
31	-	GND	32	O	HEAD SELECT
33	-	N. C. <sup>1</sup>	34	I	DSKCHG

\* Active low signal

<sup>1</sup> By default, these pins are not connected, however, by installing the W24 and W25 jumpers, these configurations are possible (see also page 9-10 in the manual):

- |       |   |                |          |   |                |
|-------|---|----------------|----------|---|----------------|
| 1) 17 | - | GND            | Or:2) 17 | I | EDOUT (2.88MB) |
| 27    | - | GND            | 27       | I | HDOUT (2.88MB) |
| 29    | I | EDOUT (2.88MB) | 29       | - | GND            |
| 33    | I | HDOUT (2.88MB) | 33       | - | GND            |



**TABLE 4-5:** Multi-Function Connector - Keyboard, Speaker, Reset, LED - (J5) - Pin-Out

Pin Number	Signal Flow	Signal	Pin Number	Signal Flow	Signal
1	I/O	KBDCLK	2	-	GND
3	I/O	KBDDATA	4	-	GND
5	-	VCC (Protected: Resettable Fuse)	6	-	VCC (Protected: Resettable Fuse)
7	O	SPEAKER	8	-	VCC (Protected: Resettable Fuse)
9	I	KBDINH	10	-	GND
11	I	DOWNLD*	12	-	GND
13	I	PBRES*	14	-	GND
15	O	ACTIVE*	16	-	VCC (Protected: Resettable Fuse)

\* Active low signal

**TABLE 4-6:** Serial Port 1 (J6) - RS232 - Pin-Out

Pin Number	Signal Flow	Signal	Pin Number	Signal Flow	Signal
1	I	DCD	2	I	DSR
3	I	RX	4	O	RTS
5	O	TX	6	I	CTS
7	O	DTR	8	I	RI
9	-	GND	10	-	Not Used

**TABLE 4-7a:** Serial Port 2 (J7) - RS232 - Pin-Out

Pin Number	Signal Flow	Signal	Pin Number	Signal Flow	Signal
1	I	DCD	2	I	DSR
3	I	RX	4	O	RTS
5	O	TX	6	I	CTS
7	O	DTR	8	I	RI
9	-	GND	10	-	Not Used

**TABLE 4-7b:** Serial Port 2 (J7) - RS485/RS422 - Pin-Out

Pin Number	Signal Flow	Signal	Pin Number	Signal Flow	Signal
1	I	DCD	2	I	DSR
3	I/O	RXD(-)	4	I/O	RXD(+)
5	O	TXD(-)	6	I	TXD(+)
7	O	DTR	8	I	RI
9	-	GND	10	-	Not Used

**TABLE 4-8:** Hard Disk Connector #2 (J8) - Pin-Out

Pin Number	Signal Flow	Signal	Pin Number	Signal Flow	Signal
1	I	RESET*	2	-	GND
3	I/O	SD7	4	I/O	SD8
5	I/O	SD6	6	I/O	SD9
7	I/O	SD5	8	I/O	SD10
9	I/O	SD4	10	I/O	SD11
11	I/O	SD3	12	I/O	SD12
13	I/O	SD2	14	I/O	SD13
15	I/O	SD1	16	I/O	SD14
17	I/O	SD0	18	I/O	SD15
19	-	GND	20	-	Not Used
21	O	REQ B	22	-	GND
23	I	IOW*	24	-	GND
25	I	IOR*	26	-	GND
27	O	IOCHRDY	28	-	Not Used
29	O	DACK B*	30	-	GND
31	O	IRQ15	32	O	IOCS16*
33	I	SA1	34	-	Not Used
35	I	SA0	36	I	SA2
37	I	CS0 B*	38	O	CS1 B*
39	O	ACTIVE*	40	-	GND

\* Active low signal

**TABLE 4-9:** Flat Panel Connector (J9) - Pin-Out

Pin Number	Signal	Pin Number	Signal
1	FP4	2	FP5
3	FP6	4	FP7
5	FP12	6	FP13
7	FP14	8	FP15
9	FP19	10	FP18
11	FP11	12	FP10
13	FP23	14	FP22
15	FP21	16	FP20
17	GND	18	FPVDCLK
19	GND	20	FP9
21	GND	22	LFS
23	FP3 (MOD)	24	FP0
25	GND	26	FPDE
27	GND	28	GND
29	FP8	30	GP0
31	GP1	32	GND
33	FPBL	34	GND
35	LLCLK	36	GND
37	FPVEE	38	FPVCC
39	FP2	40	GP2
41	STANDBY*	42	FP16
43	FP1	44	FP17
45	Not Used	46	Not Used
47	VCC (+5V)	48	VCC (+5V)
49	+12V	50	+12V

\* Active low signal

**TABLE 4-10a:** Parallel Port Connector (J10) - Standard Mode - Pin-Out

Pin Number	Signal Flow	Signal	Pin Number	Signal Flow	Signal
1	O	STROBE*	2	O	AUTOFD*
3	I/O	D0	4	I	ERROR*
5	I/O	D1	6	O	INIT*
7	I/O	D2	8	O	SELECTIN*
9	I/O	D3	10	-	GND
11	I/O	D4	12	-	GND
13	I/O	D5	14	-	GND
15	I/O	D6	16	-	GND
17	I/O	D7	18	-	GND
19	I	ACK*	20	-	GND
21	I	BUSY	22	-	GND
23	I	PE	24	-	GND
25	I	SELECT	26	-	GND

\* Active low signal

**TABLE 4-10b:** Parallel Port Connector (J10) - EPP Mode - Pin-Out

Pin Number	Signal Flow	Signal	Pin Number	Signal Flow	Signal
1	O	WRITE*	2	O	DATASTB*
3	I/O	D0	4	-	Not Used
5	I/O	D1	6	-	Not Used
7	I/O	D2	8	O	ADDRSTRB*
9	I/O	D3	10	-	GND
11	I/O	D4	12	-	GND
13	I/O	D5	14	-	GND
15	I/O	D6	16	-	GND
17	I/O	D7	18	-	GND
19	I	INTR	20	-	GND
21	I	WAIT*	22	-	GND
23	-	Not Used	24	-	GND
25	-	Not Used	26	-	GND

\* Active low signal

**TABLE 4-10c:** Parallel Port Connector (J10) - ECP Mode - Pin-Out

Pin Number	Signal Flow	Signal	Pin Number	Signal Flow	Signal
1	O	STROBE*	2	O	AUTOFD*, HOSTACK <sup>2</sup>
3	I/O	D0	4	I	FAULT* <sup>1</sup> , PERIPHRQST* <sup>2</sup>
5	I/O	D1	6	O	INIT* <sup>1</sup> , REVERSERQST* <sup>2</sup>
7	I/O	D2	8	O	SELECTIN* <sup>1,2</sup>
9	I/O	D3	10	-	GND
11	I/O	D4	12	-	GND
13	I/O	D5	14	-	GND
15	I/O	D6	16	-	GND
17	I/O	D7	18	-	GND
19	I	ACK*	20	-	GND
21	I	BUSY, PERIPHACK <sup>2</sup>	22	-	GND
23	I	PERROR, ACKREVERSE <sup>2</sup>	24	-	GND
25	I	SELECT	26	-	GND

\* Active low signal

<sup>1</sup> Compatible Mode

<sup>2</sup> High Speed Mode

Note: For more information on the ECP protocol, please refer to the Extended Capabilities Port Protocol and ISA Interface Standard (available from Microsoft Corporation) or contact our Technical Support department.

**TABLE 4-11: Video Feature Connector (J11) - Pin-Out**

I/O Pin	Signal Name	I/O Pin	Signal Name
Y1	FCP0	Z1	GND
Y2	FCP1	Z2	GND
Y3	FCP2	Z3	GND
Y4	FCP3	Z4	FCEVIDEO*
Y5	FCP4	Z5	FCESYNC*
Y6	FCP5	Z6	Not Used
Y7	FCP6	Z7	Not Used
Y8	FCP7	Z8	GND
Y9	FCCLK	Z9	GND
Y10	FCBLANK*	Z10	GND
Y11	FCHSYNC	Z11	GND
Y12	FCVSYNC	Z12	FCVCLK
Y13	GND	Z13	OVRW*

\* Active low signal

**TABLE 4-12: Optional Analog Encoder Connector (J12) - Pin-Out**

Pin Number	Signal	Pin Number	Signal
1	RED	2	GND
3	GREEN	4	GND
5	BLUE	6	GND
7	CSYNC	8	GND
9	TVON	10	NTSC_PAL
11	GND	12	OSC14M
13	VCC (+5V)	14	Not Used
15	VCC (+5V)	16	Not Used



**TABLE 4-13: PS/2 Mouse Connector (J13) - Pin-Out**

Pin Number	Signal
1	MCLK
2	GND
3	MDATA
4	VCC (Protected: Resettable Fuse)

**TABLE 4-14: Emergency BIOS Boot (J14) - Pin- Out**

Pin Number	Signal
1	EMER*
2	GND

\* Active low signal

**TABLE 4-15: VGA Connector (J15) - Pin-Out**

Pin Number	Signal	Pin Number	Signal	Pin Number	Signal
1	RED	6	ANALOG GND	11	Not Used
2	GREEN	7	ANALOG GND	12	Not Used
3	BLUE	8	ANALOG GND	13	HSYNC
4	NotUsed	9	Not Used	14	VSYNC
5	GND	10	GND	15	Not Used

**TABLE 4-16: Ethernet 10 Base-T RJ45 Connector (J16) - Pin-Out**

Pin Number	Signal Flow	Signal	Pin Number	Signal Flow	Signal
1	O	TD+	2	O	TD-
3	I/O	RD+	4	-	Not Used
5	-	Not Used	6	I	RD-
7	-	Not Used	8	-	Not Used

**TABLE 4-17: Ethernet 10 Base-2 BNC Connector (J23) - Pin-Out**

Pin Number	Signal Name
Center Conductor	Signal
Shield	GND

**Note:** The Ethernet 10 Base-2 Connector (J23) is a standard BNC connector.

## **5 SOFTWARE SETUPS**

There are two software setup programs on the TEK933:

- VIP-UP Setup: This is TEKNOR's own Setup program for enabling / disabling / relocating various hardware features on the Single Board Computer.
- AMIBIOS Setup: This is a setup utility in ROM which is used to set configuration data in CMOS RAM.

### **5.01 ACCESSING AMIBIOS SETUP PROGRAM**

The AMIBIOS Setup program can be executed during boot-up. To run the AMIBIOS Setup program incorporated into the ROM BIOS:

- Turn on or reboot the system.
- Hit the DELETE key before or when the message - "Hit <DEL> if you want to run SETUP" appears near the top of the screen (DELETE will work, even if the message display is disabled in AMIBIOS SETUP).

The screens and their options are explained in full in Section 15 - AMIBIOS SETUP.

## **5.02 ACCESSING VIP-UP PROGRAM**

This program can be executed during boot-up.

During boot-up, hit the CTRL and V keys simultaneously, before or when you see the message "Press CTRL-V to enter TEKNOR VIP-UP" at the top of the screen (CTRL-V will work, even if the message display is disabled in VIP-UP).

The screens and their options are explained in full in Section 16 - VIP-UP SETUP.

**PART TWO**  
**HARDWARE REFERENCE**

6 SYSTEM

7 PCI-ISA BUS

8 SYSTEM I/O CONTROLLER

9 IDE & FLOPPY

10 SERIAL & PARALLEL PORTS

11 SCSI

12 ETHERNET

13 VIDEO

14 POWER MANAGEMENT

## **6 SYSTEM**

This section deals with various components of the system board.

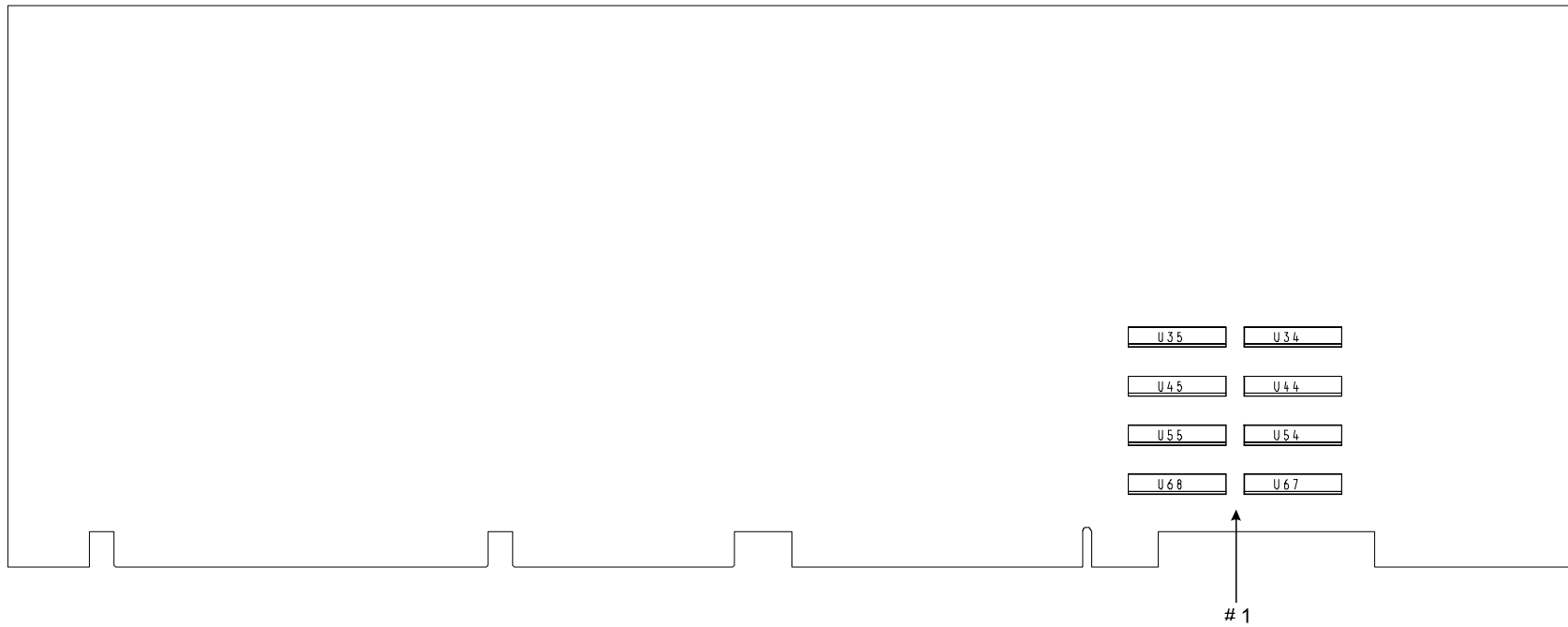
### **6.01 LOCATION OF SYSTEM COMPONENTS**

Diagram 6-1 and 6-2 show the location of the system components described in sections 6.02 to 6.12.

System components are numbered in Diagram 6-1 and 6-2. The following list shows which components these numbers correspond to, as well as the sub-section in which they are explained:

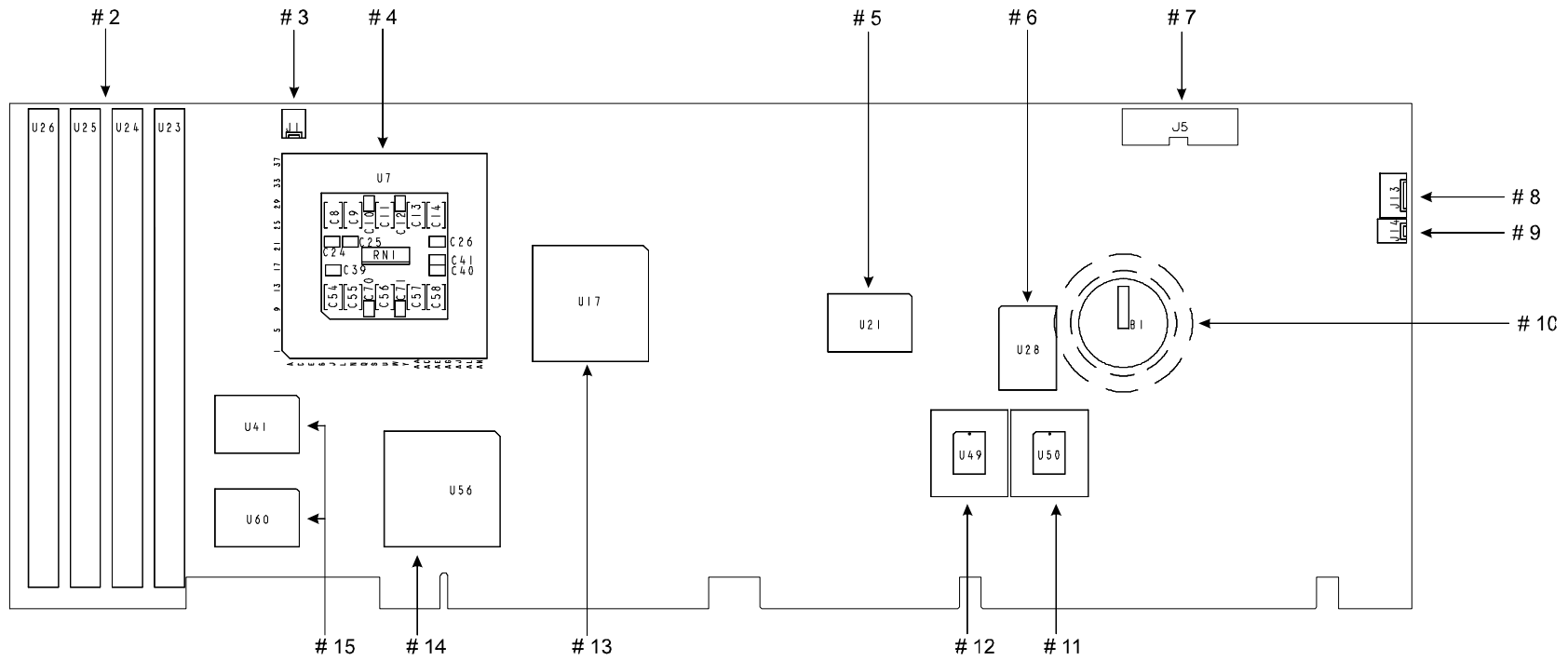
<u>#</u>	<u>COMPONENT</u>	<u>SECTION</u>
1	System Cache	6.05 - CACHE
2	System Memory (DRAM)	6.06 - SYSTEM MEMORY (DRAM)
3	Fan Connector	6.03 - FAN CONNECTOR
4	Microprocessor	6.02 - MICROPROCESSOR
5	Real Time Clock - AT Keyboard & PS/2 Mouse Controller	6.10 - REAL TIME CLOCK - AT KEYBOARD & PS/2 MOUSE CONTROLLER
6	Field Programmable Gate Array (FPGA)	6.09 - SUPERVISOR UTILITIES
7	Multi-Function Connector (Keyboard, Speaker, Reset, LED)	6.11 - MULTI-FUNCTION CONNECTOR (KEYBOARD, SPEAKER, RESET, LED)
8	PS/2 Mouse Connector	6.12 - PS/2 MOUSE CONNECTOR
9	Emergency BIOS Boot Selection	6.07 - BIOS (FLASH EPROM & EPROM)
10	VBAT Internal Battery	6.08 - BATTERY
11	Flash EPROM BIOS	6.07 - BIOS (FLASH EPROM & EPROM)
12	EPROM BIOS	6.07 - BIOS (FLASH EPROM & EPROM)
13	System Controller	6.04 - PCI/ISA SYSTEM CONTROLLER
14	PCI Bus Controller	6.04 - PCI/ISA SYSTEM CONTROLLER
15	Data Controllers	6.04 - PCI/ISA SYSTEM CONTROLLER

**DIAGRAM 6-1:** System Components Location (Bottom of Board)





**DIAGRAM 6-2: System Components Location (Top of Board)**





## 6.02 MICROPROCESSOR

The TEK933 board has an interchangeable microprocessor design; the following **supported microprocessors** are available (maximum internal CPU clock speed indicated):

- Pentium™ running at 75, 100, 120, 133, 150 and 166 MHz.

The following jumpers are related to the CPU:

- W2 & W3: Selects the desired multiplier for Pentium internal CPU clock speed:
  - W2: pins 1 and 2 shorted      for 1.5X,  
W3: pins 1 and 2 shorted
  - W2: pins 1 and 2 shorted      for 2X,  
W3: pins 2 and 3 shorted
  - W2: pins 2 and 3 shorted      for 2.5X.  
W3: pins 2 and 3 shorted
- W19, W20 & W21: Selects the desired external CPU clock (Bus) speed:
  - W19: pins 2 and 3 shorted      for 50MHz,  
W20: pins 1 and 2 shorted  
W21: pins 2 and 3 shorted
  - W19: pins 1 and 2 shorted      for 60MHz,  
W20: pins 1 and 2 shorted  
W21: pins 1 and 2 shorted
  - W19: pins 1 and 2 shorted      for 66MHz.  
W20: pins 2 and 3 shorted  
W21: pins 2 and 3 shorted

External speed is set with jumpers W19, W20 and W21 (50, 60, 66 MHz) and internal speed is set with the W2 and W3 jumpers (1.5, 2 or 2.5X the external speed, however this cannot exceed the maximum internal speed for that microprocessor).

Jumper locations and settings appear in Section 2 of this manual.

The **Pentium** processor family contains all of the features of the Intel486 CPU family, with the addition of the following **features**:

- Superscalar architecture,
- Dynamic Branch Prediction,
- Pipelined floating-point unit,
- Improved instruction execution time,
- Separate 8KB Code and 8KB Data Caches,
- Write-back MESI protocol in the Data Cache,
- 64-bit data bus,
- Bus cycle pipelining,
- Address parity,
- Internal parity checking,
- Functional redundancy checking,
- Execution tracing,
- Performance monitoring,
- IEEE 1149.1 boundary scan,
- System Management Mode,
- Virtual mode extensions,
- Dual processing support,
- SL power management features,
- Upgradable with a future Pentium overdrive processor,
- Fractional bus operation,
- On-chip local APIC device.

### 6.03 FAN CONNECTOR

The # 3 component on Diagram 6-2 is for connecting a CPU fan. Its pin-out is as follows:

**TABLE 6-1:** Fan Connector (J1) - Pin-Out

Pin Number	Signal
1	+12V
2	GND

## **6.04 PCI/ISA SYSTEM CONTROLLER**

The TEK933 board uses VIA's VT82C570M Green PC Pentium/P54C PCI/ISA System with plug and play and enhanced IDE controller. This chip set consists of the following components:

- The VT82C575M System Controller, located at U17 (#13) on Diagram 6-2,
- The VT82C576M PCI Bus Controller located at U56 (#14) on Diagram 6-2,
- The two VT82C577M Data Controllers located at U41 and U60 (#15) on Diagram 6-2, and
- The VT82C416MV integrated real time clock and keyboard controller with PS/2 mouse support, located at U21 (#5) on Diagram 6-2.

As an integrated unit, the PCI/ISA System Controller offers the following features:

### **DRAM Controller**

- CPU/Cache to DRAM write buffer,
- SIMM module support: 72-pin configuration,
- Integrated DRAM controller:
  - Supports CPU and PCI master accesses to System Memory,
  - Supports 2MB to 128MB (256MB when available) of Cacheable System Memory (DRAM).

### **Cache Controller**

- Direct mapped write back or write through secondary Cache,
- Cache hit cycle of 3-2-2-2 on reads and 4-2-2-2 on writes using standard asynchronous SRAMs at 60 and 66 MHz clock speed,
  - Flexible Cache size up to 1MB,
- Integrated 10-bit tag comparator,
- Concurrent DRAM write-back.

### **ISA Bus Interface**

- Synchronous ISA bus clock,
- Programmable command delay and I/O recovery time,
- One level of post write buffer,
- Flash EPROM and combined BIOS support,
- ISA Bus (P996 standard compliant),
- High-drive buffers to support up to 20 slots,
- Integrates the functionality of two 8237 DMA Controllers (see Table 6-2), two 8259 Interrupt Controllers (see Table 6-3) and one 8254 Counter/Timer,
- A steering logic feature insures that the slower ISA bus traffic does not block the PCI bus traffic.

**TABLE 6-2:** 8237 DMA Controllers

DMA 0	Available
DMA 1	PnP available (ECP)
DMA 2	Floppy controller
DMA 3	PnP available (ECP or Ethernet)
DMA 4	Cascade controller # 1
DMA 5	PnP available (Ethernet)
DMA 6	PnP available (Ethernet)
DMA 7	PnP available (Ethernet)

According to Plug and Play standards, the System BIOS automatically allocates DMA Channel 1 or 3 for the parallel port's ECP mode. Channel 2 is reserved for the Floppy controller and Channel 4 is used to cascade Channels 0 through 7 to the microprocessor. The DMA Channel for the Plug and Play Ethernet device is automatically allocated by the System BIOS among those available (Channel 3, 5, 6 or 7).

**TABLE 6-3: 8259 Interrupt Controllers**

Controller # 1		Controller # 2	
IRQ 0	Timer 0	IRQ 8	Real-time clock
IRQ 1	Keyboard	IRQ 9	Available <sup>1</sup>
IRQ 2	Cascade controller # 2	IRQ 10	Available <sup>1</sup>
IRQ 3	COM 2 *	IRQ 11	Available <sup>1</sup>
IRQ 4	COM 1 *	IRQ 12	PS/2 Mouse Interface
IRQ 5	LPT2 * or available <sup>1</sup>	IRQ 13	Coprocessor Error
IRQ 6	Floppy controller *	IRQ 14	Primary IDE * or available <sup>1</sup>
IRQ 7	LPT1 * or available <sup>1</sup>	IRQ 15	Secondary IDE * or available <sup>1</sup>

\* All functions marked with an asterisk (\*) can be disabled or reconfigured.

<sup>1</sup> Available lines service on board and external PCI/PnP devices (when set to PCI/PnP in AMIBIOS PCI/PnP Setup screen) or an external non-PnP device (when set to ISA/EISA in AMIBIOS PCI/PnP Setup screen).

Two 8259 interrupt controllers handle the interrupts on the TEK933 as follow:

- Six interrupt lines are directly linked to the keyboard controller, timer, the real-time clock, both serial ports and the mouse.
- The System BIOS automatically allocates IRQ5 or IRQ7 for the parallel port's IRQ line, depending on the settings in the AMIBIOS Peripheral Setup's OnBoard Parallel Port option: IRQ5 when the option is set to 278h or 3BCh; IRQ7 when set to 378h; IRQ5 or IRQ7 when set to Auto; when the option is set to Disabled, IRQ5 and IRQ7 are available for onboard and external PCI/PnP devices, or for external non-PnP devices (see note 1 above).
- The Primary and Secondary IDE Controller are configured to IRQ 14 and IRQ 15 respectively or to none by software:
  - IRQ 14: When the AMIBIOS Peripheral Setup screen's OnBoard IDE option is set to Primary or to Both, this line is linked to Primary IDE,
  - IRQ 15: When the AMIBIOS Peripheral Setup screen's OnBoard IDE option is set to Secondary or to Both, this line is linked to Secondary IDE,
  - None: When the AMIBIOS Peripheral Setup screen's OnBoard IDE option is set to Disabled, IRQ 14 and IRQ 15 are available for on board/external PCI/PnP devices or external non-PnP devices (see note 1 above).



- The on board PCI SCSI Controller is automatically allocated an IRQ line by the System BIOS among the available PCI/PnP IRQ lines.
- The on board Plug and Play Ethernet is automatically allocated an IRQ line by the System BIOS among the available PCI/PnP IRQ lines.

#### **PCI Bus Controller**

- 32-bit PCI interface,
- Concurrent PCI Master/CPU/IDE operations,
- High performance CPU/PCI/Memory interfaces via posted write and read prefetch buffers,
- PCI Masters to DRAM posted write buffers,
- Prefetch buffers from DRAM for access by PCI Masters,
- CPU-to-PCI posted write buffers accelerate write performance,
- PCI 2.1 compliant,
- Zero wait state PCI Master and Slave burst transfer rates,
- High bus throughput via multiple accelerated schemes,
- Supports PCI Configuration Access Mechanisms #1 and #2,
- Automatic detection of data steaming burst cycles from CPU to the PCI bus.

**PCI IDE Controller**

- Dual IDE channels control four peripheral devices, including support for non-disk IDE devices such as CD-ROM,
- Sixteen-level 32-bit prefetch and write buffers for each IDE channel,
- Separate IDE data bus and control signals from the PCI and ISA bus, providing load reduction and enhanced performance,
- Supports PIO mode-4 and mode-5 transfer rates,
- Complete software driver support,
- A steering logic feature ensures that the slower IDE traffic does not block the PCI bus traffic.

**Plug and Play Controller**

- Microsoft Windows 95 and Plug and Play BIOS compliant.

**Power Management Unit**

- Normal, Sleep and Suspend modes,
- Monitoring through idle, peripheral and general purpose timers,
- Preset I/O range,
- Multiple internal and external SMI sources.

## 6.05 CACHE

There are two separate Caches in the Host subsystem: Internal Cache and External Cache. The Cache inside the Pentium processor (Internal Cache) is referred to as the first level Cache (also primary Cache). The External Cache (called System Cache in this manual) comprises the System Controller's Cache control circuitry and associated external memory array; it is referred to as the second level Cache (also secondary Cache). The second level Cache is unified, which means that both CPU data and instructions are stored in the Cache.

### 6.05.1 SYSTEM CACHE

The System Controller integrates a high performance write-back / write-through second level Cache controller, tag RAM and a full first and second level Cache coherency mechanism. The System Controller supports a direct-mapped secondary Cache.

System Cache is located at the back of the card at U34, U35, U44, U45, U54, U55, U67 and U68 (#1) on Diagram 6-1; it accepts a total of 256KB standard asynchronous SRAM.

System Cache copies the most recently accessed data and places it in an area of high speed memory called SRAM (Static RAM). Cache SRAM is positioned between System Memory (DRAM) and the CPU. Data is transferred from System Memory to Cache and then from Cache to the CPU.

Since most program executions are sequential and repetitive, the likelihood is great that the CPU will find data already stored in either Cache. When the CPU retrieves data from Cache, a **Cache hit** occurs. On the other hand, when the CPU must access data from System Memory, a **Cache miss** occurs.

System Cache is enabled and configured in the AMIBIOS Setup program (see Section 15).

## **6.06 SYSTEM MEMORY (DRAM)**

A local DRAM controller is integrated in the System Controller. Dynamic Random Access Memory (DRAM) is essential system memory. The memory array is 64 bits wide and ranges in size from 2MB to 128MB (256MB when available). The array is implemented using single-sided or double-sided SIMMs (Single In-line Memory Modules). See section 1 for instructions on configuring and installing SIMMs.

The location of the four 72-pin vertical SIMM sockets appears on Diagram 6-2 at U23, U24, U25 and U26 (# 2).

The DRAM Controller supports CPU and PCI master accesses to System Memory. The System Controller's DRAM interface supplies the control signals and address lines; the Data Controllers supply the data path from or to the CPU; and the PCI Controller's DRAM interface provides a 32-bit data link to the System Memory to allow for concurrent CPU/Cache and PCI Master/DRAM operations.

## 6.07 BIOS (FLASH EPROM & EPROM)

The Flash EPROM BIOS and the EPROM BIOS are factory installed. The Flash EPROM BIOS appears on Diagram 6-2 at U50 (#11) and the EPROM BIOS at U49 (#12).

By default the TEK933 boots from the Flash EPROM BIOS. This is set by the J14 Emergency BIOS boot selection jumper (# 9 on Diagram 6-2), as follows:

- J14 : Selects the BIOS to boot from:
  - Shorted: Emergency boot (from EPROM BIOS),
  - Or open: Normal boot (from Flash EPROM BIOS): This is the initial setting.

The pin-out for J14 appears below:

**TABLE 6-4:** Emergency BIOS Boot (J14) - Pin-Out

Pin Number	Signal
1	EMER*
2	GND

\* Active low signal

## 6.08 BATTERY

The TEK933 comes with a 360 mAh TL5186 TADIRAN battery, which is located at B1 (#10 on Diagram 6-2). It powers the Real Time Clock and the CMOS Setup, whenever the board is powered down.

The TL5186 TADIRAN battery has a shelf life of approximately 10 years (under "no-load" conditions). The actual life of the battery depends on environmental (temperature) conditions. The TADIRAN TL5186 has an operating range of -55° to 75°C and discharge characteristics vary with temperature.

The voltage supplied by the battery is 3.6 volts. This can be verified with a standard voltmeter at the battery socket's two extreme pins (if you use the pin on the soldered side, you do not have to remove the battery).

Jumper W27 enables the Internal Battery's power. Removing the W27 jumper has the same effect as putting the battery in storage; TEKNOR always ships its board with battery jumper removed in order to increase the life of the battery. Please refer to Section 2 for jumper location and setting.

The TADIRAN TL5186 is UL recognized. Its UL component recognition is MH12193.

The TEK933 board has a special feature that allows the CMOS RAM Setup to be saved in Flash EPROM memory. This feature eliminates battery dependency by saving and recovering the CMOS RAM Setup from Flash (only the time and date could be lost).

☞ **In order to save your current CMOS RAM Setup in Flash, you must update the VIP-UP Setup (with F10), while the "Use Flash To Store CMOS RAM SETUP" (first screen) is set to "Yes". See section 16 for more information.**

## 6.09 SUPERVISOR UTILITIES

Component #6 on Diagram 6-2 is defined on page 6-2 as Field Programmable Gate Array (FPGA); this memory device contains registers, one of which is described below.

TEKNOR computers utilize address space 190H, 290H or 390H (depending on the setting of W9 jumper for I/O base address) to enable special features (see Table 6-5 below).

**TABLE 6-5:** Register 190H, 290H or 390H

Bit #	Bit Value (Default)	Function: WRITE	READ
0	0	Enable Watchdog 1=enable, R/W bit	Same
1	1	Watchdog activate 1-0-1 to toggle, R/W bit	Same
2	0	Flash VPP enable	Same
3	0	Enable direction control RS-485 1=enable RS-485 only, write only	Power Detection Output or Battery Low output
4	0	Reserved, ENWF	W8 (7-8) Status
5	0	Reserved, ENWB	W8 (5-6) Status
6	1	Reserved, B64/16	W8 (3-4) Status
7	0	Reserved (Video Standby) <sup>1</sup>	W8 (1-2) Status

<sup>1</sup> Contact TEKNOR Technical Support if a Video Standby software is required.

☞ **Not all bits are R/W. Therefore, be certain to keep a mirror image of the register when programming it.**

☞ **All bits are 0 after a hardware RESET or power up condition.**

☞ **Write the values shown in the "Bit Value (Default)" column if you are unsure.**

## **6.10 REAL TIME CLOCK - AT KEYBOARD & PS/2 MOUSE CONTROLLER**

The integrated real time clock generator and AT Keyboard and PS/2 Mouse Controller is located at U21 (#5 on Diagram 6-2). Its features are as follows:

- Complete operating system independence.
- Works with DOS, Microsoft Windows<sup>®</sup>, OS/2<sup>®</sup>, and Unix.
- High-level functional integration.



### 6.11 MULTI-FUNCTION CONNECTOR (KEYBOARD, SPEAKER, RESET, LED)

Connector J5 (#7 on Diagram 6-2) provides all the necessary signals for connecting the keyboard, speaker, reset, and keylock interface devices. The following diagram shows the pin-out at J5:

**TABLE 6-6:** Multi-Function Connector - Keyboard, Speaker, Reset, LED - (J5) - Pin-Out

Pin Number	Signal Flow	Signal	Pin Number	Signal Flow	Signal
1	I/O	KBDCLK	2	-	GND
3	I/O	KBDDATA	4	-	GND
5	-	VCC (Protected: Resettable Fuse)	6	-	VCC (Protected: Resettable Fuse)
7	O	SPEAKER	8	-	VCC (Protected: Resettable Fuse)
9	I	KBDINH	10	-	GND
11	I	DOWNLD*	12	-	GND
13	I	PBRES*	14	-	GND
15	O	ACTIVE*	16	-	VCC (Protected: Resettable Fuse)

\* Active low signal

The following functions are available on the J5 Connector:

- Speaker: An 8 ohm speaker can be directly connected to pins 7 and 8 of J5. All necessary drivers are on the board.
- Keyboard Disable: The keyboard can be disabled or locked up by shorting pins 9 and 10 of J5.
- Hard Disk LED: The onboard IDE interface activates an external LED. The LED must be connected anode on pin 16 (J5) and cathode on pin 15 (J5). No external current limiting resistor is required since one is already present on the board.
- Reset: Manually reset the system by driving PBRES\* to low state (< 0.8 V).

## 6.12 PS/2 MOUSE CONNECTOR

The board supports a mouse, through the PS/2 connector at J13 (#8 on Diagram 6-2). With the PS/2 Mouse Cable (available from TEKNOR), this feature is compatible with the standard IBM PS/2 mouse. The cable may be ordered by contacting our Sales department.

During installation of the mouse, you must install the driver provided by the mouse manufacturer.

**TABLE 6-7:** PS/2 Mouse Connector (J13) - Pin-Out

Pin Number	Signal
1	MCLK
2	GND
3	MDATA
4	VCC (Protected: Resettable Fuse)

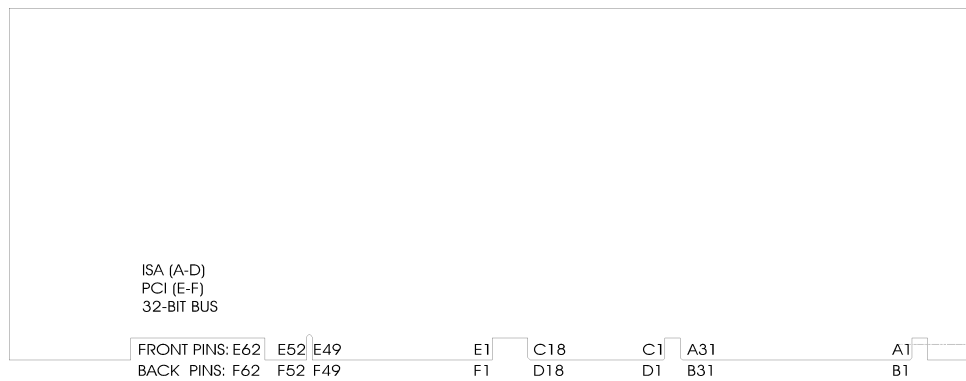
To enable the mouse, set the Mouse Support option (PS/2) to Enabled in the Advanced Setup screen of the AMIBIOS Setup program.

## 7 PCI-ISA BUS

### 7.01 LOCATION OF PCI-ISA BUS CONNECTOR

The PCI-ISA bus connector appears on the diagram below.

**DIAGRAM 7-1: PCI-ISA Bus Connector Location**



## 7.02 PCI-ISA CONNECTOR PIN-OUTS

**TABLE 7-1a: ISA Bus Connector (A, B)**

### A SIDE

I/O PIN	Signal Name	I/O
A1	IOCHK*	I
A2	SD7	I/O
A3	SD6	I/O
A4	SD5	I/O
A5	SD4	I/O
A6	SD3	I/O
A7	SD2	I/O
A8	SD1	I/O
A9	SD0	I/O
A10	IOCHRDY	I
A11	AEN	O
A12	SA19	I/O
A13	SA18	I/O
A14	SA17	I/O
A15	SA16	I/O
A16	SA15	I/O
A17	SA14	I/O
A18	SA13	I/O
A19	SA12	I/O
A20	SA11	I/O
A21	SA10	I/O
A22	SA9	I/O
A23	SA8	I/O
A24	SA7	I/O
A25	SA6	I/O
A26	SA5	I/O
A27	SA4	I/O
A28	SA3	I/O
A29	SA2	I/O
A30	SA1	I/O
A31	SA0	I/O

### B SIDE

I/O PIN	Signal Name	I/O
B1	GND	-
B2	RESET DRV	O
B3	VCC (+5V)	-
B4	IRQ9	I
B5	Not Used	-
B6	DRQ2	I
B7	-12V	-
B8	OWS*	I
B9	+12V	-
B10	GND	-
B11	SMEMW*	O
B12	SMEMR*	O
B13	IOW*	I/O
B14	IOR*	I/O
B15	DACK3*	O
B16	DRQ3	I
B17	DACK1*	O
B18	DRQ1	I
B19	REFRESH*	I/O
B20	SYSCLK	O
B21	IRQ7	I
B22	IRQ6	I
B23	IRQ5	I
B24	IRQ4	I
B25	IRQ3	I
B26	DACK2*	O
B27	T/C	O
B28	BALE	O
B29	VCC (+5V)	-
B30	OSC	O
B31	GND	-

\* Active low signal

**TABLE 7-1b: ISA Bus Connector (C, D)**

**C Side**

I/O PIN	Signal Name	I/O
C1	SBHE*	I/O
C2	LA23	I/O
C3	LA22	I/O
C4	LA21	I/O
C5	LA20	I/O
C6	LA19	I/O
C7	LA18	I/O
C8	LA17	I/O
C9	MEMR*	I/O
C10	MEMW*	I/O
C11	SD08	I/O
C12	SD09	I/O
C13	SD10	I/O
C14	SD11	I/O
C15	SD12	I/O
C16	SD13	I/O
C17	SD14	I/O
C18	SD15	I/O

**D Side**

I/O PIN	Signal Name	I/O
D1	MEMCS16*	I
D2	IOCS16*	I
D3	IRQ10	I
D4	IRQ11	I
D5	IRQ12	I
D6	IRQ15	I
D7	IRQ14	I
D8	DACK0*	O
D9	DRQ0	I
D10	DACK5*	O
D11	DRQ5	I
D12	DACK6*	O
D13	DRQ6	I
D14	DACK7*	O
D15	DRQ7	I
D16	VCC (+5V)	-
D17	MASTER*	I
D18	GND	-

\* Active low signal

**TABLE 7-2a: PCI Bus Connector (E1-E30, F1-F30)**

**E SIDE**

**F SIDE**

I/O PIN	Signal Name	I/O	I/O PIN	Signal Name	I/O
E1	VCC (+5V)	-	F1	-12V	-
E2	+12V	-	F2	Not Used	-
E3	Not Used	-	F3	GND	-
E4	TD	-	F4	TD	-
E5	VCC	-	F5	VCC (+5V)	-
E6	INTA*	I	F6	VCC (+5V)	-
E7	INTC*	I	F7	INTB*	I
E8	VCC (+5V)	-	F8	INTD*	I
E9	PCLK4-Slot 3	O	F9	REQ3*	I
E10	VCC (+5V)	-	F10	REQ1*	I
E11	PCLK4-Slot 4	O	F11	GNT3*	O
E12	GND	-	F12	GND	-
E13	GND	-	F13	GND	-
E14	GNT1*	O	F14	PCLK3-Slot 1	O
E15	RESET*	O	F15	GND	-
E16	VCC (+5V)	-	F16	PCLK3-Slot 2	O
E17	GNT0*	O	F17	GND	-
E18	GND	-	F18	REQ0*	I
E19	REQ2*	I	F19	VCC (+5V)	-
E20	AD30	I/O	F20	AD31	I/O
E21	Not Used	-	F21	AD29	I/O
E22	AD28	I/O	F22	GND	-
E23	AD26	I/O	F23	AD27	I/O
E24	GND	-	F24	AD25	I/O
E25	AD24	I/O	F25	Not Used	-
E26	GNT2*	O	F26	C/BE3*	I/O
E27	Not Used	-	F27	AD23	I/O
E28	AD22	I/O	F28	GND	-
E29	AD20	I/O	F29	AD21	I/O
E30	GND	-	F30	AD19	I/O

\* Active low signal

**TABLE 7-2b: PCI Bus Connector (E31-E62, F31-F62)**

**E SIDE**

**F SIDE**

I/O PIN	Signal Name	I/O	I/O PIN	Signal Name	I/O
E31	AD18	I/O	F31	Not Used	-
E32	AD16	I/O	F32	AD17	I/O
E33	Not Used	-	F33	C/BE2*	I/O
E34	FRAME*	O	F34	GND	-
E35	GND	-	F35	IRDY*	O
E36	TRDY*	I	F36	Not Used	-
E37	GND	-	F37	DEVSEL*	I
E38	STOP*	I	F38	GND	-
E39	Not Used	-	F39	PLOCK*	I/O
E40	SDONE	I/O	F40	PERR*	I/O
E41	SBO*	I/O	F41	Not Used	-
E42	GND	-	F42	SERR*	I/O
E43	PAR	I/O	F43	Not Used	-
E44	AD15	I/O	F44	C/BE1*	I/O
E45	Not Used	-	F45	AD14	I/O
E46	AD13	I/O	F46	GND	-
E47	AD11	I/O	F47	AD12	I/O
E48	GND	-	F48	AD10	I/O
E49	AD9	I/O	F49	GND	-
	CONNECTOR KEY			CONNECTOR KEY	
	CONNECTOR KEY			CONNECTOR KEY	
E52	C/BE0*	I/O	F52	AD8	I/O
E53	Not Used	-	F53	AD7	I/O
E54	AD6	I/O	F54	Not Used	-
E55	AD4	I/O	F55	AD5	I/O
E56	GND	-	F56	AD3	I/O
E57	AD2	I/O	F57	GND	-
E58	AD0	I/O	F58	AD1	I/O
E59	VCC (+5V)	-	F59	VCC (+5V)	-
E60	REQ64*	I/O	F60	ACK64*	I/O
E61	VCC (+5V)	-	F61	VCC (+5V)	-
E62	VCC (+5V)	-	F62	VCC (+5V)	-

\* Active low signal



### **7.03 PCI-ISA CONNECTOR DESCRIPTION**

The PCI-ISA connector on the TEK933 conforms to the PCI INDUSTRIAL COMPUTER MANUFACTURERS GROUP (PICMG), Revision 2 specification. The basic architecture generally follows the PCI Local Bus and the ISA Bus.

The TEK933 PCI-ISA board is designed to interface with both ISA and PCI peripheral boards mounted on a passive backplane via its ISA-bus connector and PCI-bus connector.

The standard 32-bit PCI-ISA connector contains a total of 218 pins.

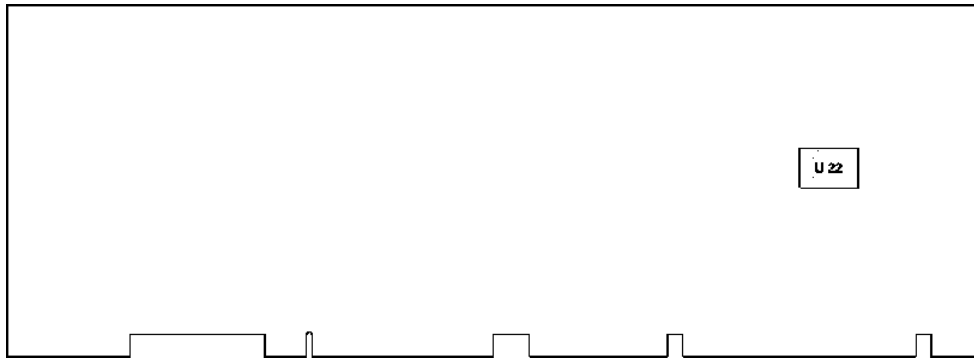
The PCI-ISA connector is defined as an ISA-bus connector followed by a PCI-bus connector. The ISA connector contains all the signals defined for ISA bus interface. The PCI connector contains all the signals defined for PCI bus interface.

## 8 SYSTEM I/O CONTROLLER

### 8.01 LOCATION OF SYSTEM I/O CONTROLLER

The System I/O Controller (for Floppy drives and Parallel and Serial ports) appears on Diagram 8-1 at U22.

**DIAGRAM 8-1:** System I/O Controller Location



## 8.02 SYSTEM I/O CONTROLLER FEATURES

The following features are incorporated in the System I/O Controller:

- Super I/O Floppy Disk Controller:
  - Supports two floppy disk drives, including single, double and high density drives with capacities ranging from 360KB up to 2.88MB.
  - Supports vertical recording format.
  - 100% IBM<sup>®</sup> compatible.
  - Detects all overrun and underrun conditions.
  - 48 mA drivers and Schmitt trigger inputs.
  - DMA enable logic.
  - Data rate and drive control registers.
  - Swap drives A and B.
  - Non-burst mode DMA option.
  - Floppy Disk Controller primary/secondary address selection.
  - 16 byte data FIFO.
  
- Enhanced Digital Data Separator:
  - Data rates: 1MB/s, 500KB/s, 300KB/s and 250KB/s.
  - Supports floppy disk drives and tape drives.
  - Programmable precompensation modes.

- Multi-Mode Parallel Port:
  - Standard Mode: IBM PC/XT<sup>®</sup>, PC/AT<sup>®</sup>, and PS/2 compatible bidirectional Parallel Port.
  - Enhanced Mode: Enhanced Parallel Port (EPP) compatible.
  - High Speed Mode: Microsoft and Hewlett Packard Extended Capabilities Port (ECP) compatible.
  - Incorporates ChiProtect circuitry for protection against damage due to printer power-on.
  - 24 mA output drivers.
  
- Serial Ports:
  - Two high speed UARTs with send/receive 16 byte FIFOs.
  - MIDI compatible.
  - Programmable baud rate generator.
  - Modem control circuitry.
  
- General Purpose 11 Bit Address Decoder:

## **9 IDE & FLOPPY**

### **9.01 INSTALLING IDE DEVICES**

#### **9.01.1 TYPE OF HARD DISK SUPPORTED**

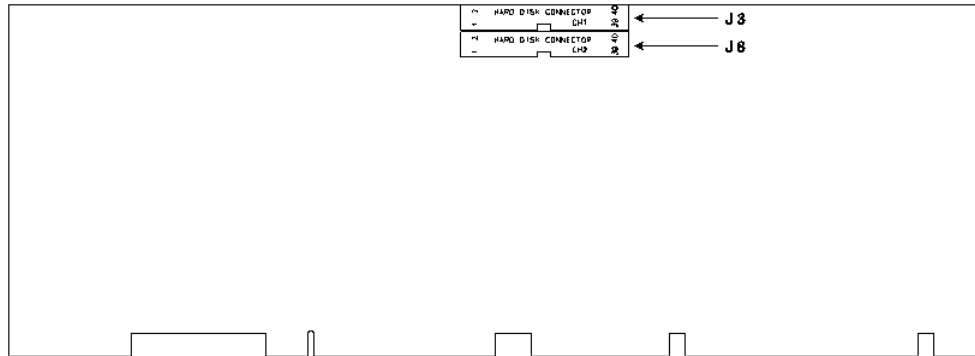
The TEK933 supports AT Integrated Disk Drives. The AT embedded drive architecture incorporates drive electronics and controller circuitry on a single printed circuit board which is mounted directly on the disk drive chassis.

The integration of drive and controller functions increases reliability and performance by eliminating redundant circuitry, thus enhancing performance at a reduced cost.

### 9.01.2 IDE CONNECTORS LOCATION & PIN-OUT

The IDE connectors appear on Diagram 9-1 at J3 and J8.

**DIAGRAM 9-1:** IDE Connectors Location



The IDE Connectors' pin-outs appear in Tables 9-1a and 9-1b.

**TABLE 9-1a: Hard Disk Connector #1 (J3) - Pin-Out**

Pin Number	Signal Flow	Signal	Pin Number	Signal Flow	Signal
1	I	RESET*	2	-	GND
3	I/O	SD7	4	I/O	SD8
5	I/O	SD6	6	I/O	SD9
7	I/O	SD5	8	I/O	SD10
9	I/O	SD4	10	I/O	SD11
11	I/O	SD3	12	I/O	SD12
13	I/O	SD2	14	I/O	SD13
15	I/O	SD1	16	I/O	SD14
17	I/O	SD0	18	I/O	SD15
19	-	GND	20	-	Not Used
21	O	REQ A	22	-	GND
23	I	IOW*	24	-	GND
25	I	IOR*	26	-	GND
27	O	IOCHRDY	28	-	Not Used
29	O	DACK A*	30	-	GND
31	O	IRQ14	32	O	IOCS16*
33	I	SA1	34	-	Not Used
35	I	SA0	36	I	SA2
37	I	CS0 A*	38	O	CS1 A*
39	O	ACTIVE*	40	-	GND

\* Active low signal

**TABLE 9-1b: Hard Disk Connector #2 (J8) - Pin-Out**

Pin Number	Signal Flow	Signal	Pin Number	Signal Flow	Signal
1	I	RESET*	2	-	GND
3	I/O	SD7	4	I/O	SD8
5	I/O	SD6	6	I/O	SD9
7	I/O	SD5	8	I/O	SD10
9	I/O	SD4	10	I/O	SD11
11	I/O	SD3	12	I/O	SD12
13	I/O	SD2	14	I/O	SD13
15	I/O	SD1	16	I/O	SD14
17	I/O	SD0	18	I/O	SD15
19	-	GND	20	-	Not Used
21	O	REQ B	22	-	GND
23	I	IOW*	24	-	GND
25	I	IOR*	26	-	GND
27	O	IOCHRDY	28	-	Not Used
29	O	DACK B*	30	-	GND
31	O	IRQ15	32	O	IOCS16*
33	I	SA1	34	-	Not Used
35	I	SA0	36	I	SA2
37	I	CS0 B*	38	O	CS1 B*
39	O	ACTIVE*	40	-	GND

\* Active low signal

### 9.01.3 IDE HOOK-UP

For hooking up either connector, a 40-pin dual row header signal connector is required. This connector handles all command, data and status I/O lines. Its recommended maximum cable length is 18-24 inches. It connects directly with the onboard 40pin male header connector at J3 or J8.

The drive itself can be mounted on any horizontal or vertical plane.

For a list of recommended devices and connectors, see Appendix D-RECOMMENDED DEVICES & MATING CONNECTORS.



#### 9.01.4 IDE SOFTWARE SETUP

##### AMIBIOS Setup

Starting from the AMIBIOS Setup program's main menu, use the following procedure to complete the setup:

- From the Setup window, select the Standard icon.
- From the Standard Setup screen, select the Pri Master icon, Pri Slave icon, Sec Master icon or Sec Slave icon.
- Select TYPE: an options list displays all valid disk drive types. Select the correct type and press ENTER.
- You can also enter the hard disk drive parameters: Type, Cylinders, Heads, Write Precompensation, Landing Zone, Sectors, and Capacity. This is done by selecting the type USER.
- By selecting BLOCK MODE, you can set the IDE BLOCK MODE option (ON or OFF). This option enables or disables multiple sector reads and writes for IDE drives.
- By selecting LBA/LARGE MODE, you can set AMIBIOS to support IDE hard disk capacities greater than 500MB. This option enables or disables the LBA (Logical Block Address) mode for the specified drive. This mode is needed to support IDE partitions greater than 500MB. **IMPORTANT:** When you enable LBA mode, your hard drive must not be partitioned. Remove partitions before enabling LBA mode (under DOS, use the FDISK command).
- Return to the main menu, and select the Peripheral icon from the Setup window.
- In the Peripheral Setup screen, the ONBOARD IDE option may be set to Disabled, Both (enable both IDE controllers), Primary (enable primary IDE controller) or Secondary (enable secondary IDE controller).

For more detail, refer to Section 15 - AMIBIOS SETUP.

## **9.02 INSTALLING FLOPPY DEVICES**

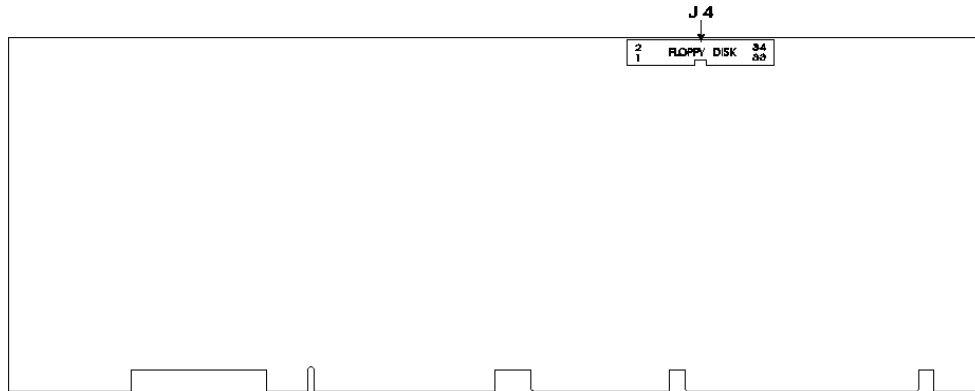
### **9.02.1 TYPES OF FLOPPY DEVICES SUPPORTED**

The floppy disk controller is IBM PC XT/AT compatible (single and double density) and supports Enhanced Floppy Mode (2.88MB). It handles 3.5 inch and 5.25 inch, low and high density drives. Up to two drives can be supported in any combination.

### 9.02.2 FLOPPY CONNECTOR LOCATION & PIN-OUT

The Floppy connector appears on Diagram 9-2 at J4.

**DIAGRAM 9-2:** Floppy Connector Location



The Floppy Connector's pin-out appears in Table 9-2.

**TABLE 9-2:** Floppy Disk Connector (J4) - Pin-Out

Pin Number	Signal Flow	Signal	Pin Number	Signal Flow	Signal
1	-	GND	2	O	RPM/LC
3	-	GND	4	-	Not Used
5	-	GND	6	-	Not Used
7	-	GND	8	I	INDEX*
9	-	GND	10	O	MOTOR ON 0,1*
11	-	GND	12	O	DRIVE SELECT B
13	-	GND	14	O	DRIVE SELECT A
15	-	GND	16	O	MOTOR ON 2*
17	-	N. C. <sup>1</sup>	18	O	DIR CONTROL
19	-	GND	20	O	STEP*
21	-	GND	22	O	WRITE DATA*
23	-	GND	24	O	WRITE ENABLE*
25	-	GND	26	I	TRACK0*
27	-	N. C. <sup>1</sup>	28	I	WRITE PROTECT*
29	-	N. C. <sup>1</sup>	30	I	READ DATA*
31	-	GND	32	O	HEAD SELECT
33	-	N. C. <sup>1</sup>	34	I	DSKCHG

\* Active low signal

<sup>1</sup> By default, these pins are not connected; however, by installing the W24 and W25 jumpers, these configurations are possible (see also page 9-10 in the manual):

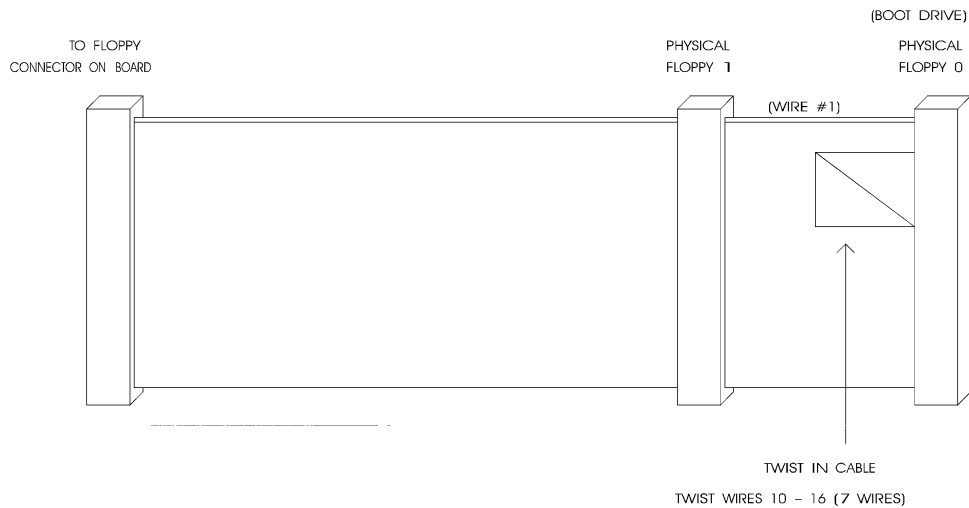
- |       |   |                |           |   |                |
|-------|---|----------------|-----------|---|----------------|
| 1) 17 | - | GND            | Or: 2) 17 | I | EDOUT (2.88MB) |
| 27    | - | GND            | 27        | I | HDOUT (2.88MB) |
| 29    | I | EDOUT (2.88MB) | 29        | - | GND            |
| 33    | I | HDOUT (2.88MB) | 33        | - | GND            |

### 9.02.3 FLOPPY HOOK-UP

#### Mechanical Floppy Disk Installation:

The installation of the floppy drives is done via a standard IBM 34-pin flat ribbon cable that connects to J4.

**DIAGRAM 9-3:** Floppy Disk Cable



#### Enhanced Floppy Mode:

In order to connect your 2.88MB floppy drive, simply indicate the proper floppy disk drive in the AMIBIOS Setup program (Section 15). It is not necessary to set the HDOUT and EDOUT media detection signal jumpers.

#### 9.02.4 FLOPPY JUMPERS

There are three possible jumper configurations for the 2.88MB High Density Floppy EDOUT and HDOUT signals:

Note:

These jumpers are **optional**. Your 2.88 MB Floppy Drive will operate correctly if 2.88MB is indicated in the BIOS Setup. Not installing these jumpers will work for all floppy disk drives, as long as the proper floppy type is indicated in AMIBIOS Setup. For proper operation, we recommend you **not** install these jumpers.

- (1) W24: No jumper: EDOUT left to software, and  
W25: No jumper: HDOUT left to software: This is the initial setting.
- (2) W24: Short Pins 1 and 3: EDOUT to Pin 29 (J4), and  
Short Pins 2 and 4: Ground to Pin 17 (J4), and  
W25: Short Pins 1 and 3: HDOUT to Pin 33 (J4), and  
Short Pins 2 and 4: Ground to Pin 27 (J4).
- (3) W24: Short Pins 1 and 2: EDOUT to Pin 17 (J4), and  
Short Pins 3 and 4: Ground to Pin 29 (J4), and  
W25: Short Pins 1 and 2: HDOUT to Pin 27 (J4), and  
Short Pins 3 and 4: Ground to Pin 33 (J4).

For location and settings of jumpers, refer to Section 2 of this manual.

## 9.02.5 FLOPPY SOFTWARE SETUP

### AMIBIOS Setup

Starting from the AMIBIOS Setup program's main menu, use the following procedure to complete the setup:

- From the Setup window, select the Standard icon.
- From the Standard Setup screen, select the Floppy A icon (or the Floppy B icon).
- The settings are 360KB 5¼ inch, 1.2MB 5¼ inch, 720KB 3½ inch, 1.44MB 3½ inch, or 2.88MB 3½ inch.

## **10 SERIAL & PARALLEL PORTS**

### **10.01 SERIAL PORTS**

There are two 16C550 compatible serial ports. These have internal 16-byte FIFO buffers for more efficient data transfers.

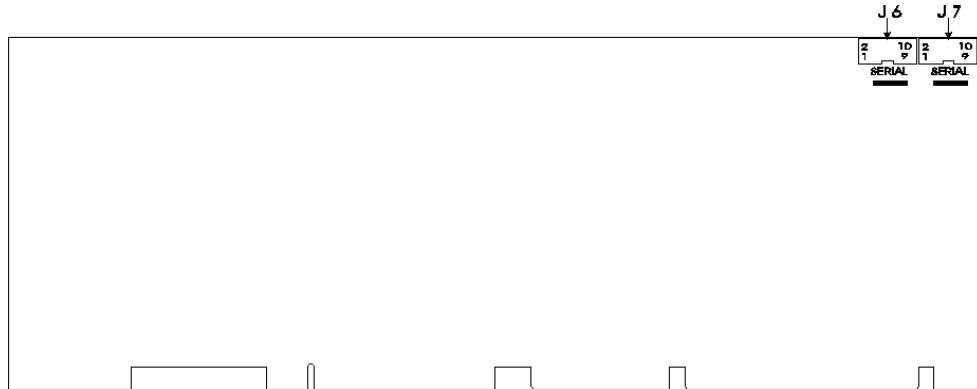
For information on the programming of serial ports with the use of FIFO buffers, you can ask for Application Note # AN93007 from TEKNOR's Technical Support department.



### 10.01.1 SERIAL PORTS LOCATION & PIN-OUTS

Serial Port 1 and Serial Port 2 appear on Diagram 10-1 at J6 and J7 respectively.

**DIAGRAM 10-1:** Serial Ports Location



### Serial Port 1 (J6) RS232

The Serial Port 1 is configured as RS232. With the IBM 9-pin DSUB Standard, Serial Port 1 is 100% compatible with the IBM-AT serial port. The following tables show their pin-outs:

**TABLE 10-1a:** Serial Port 1 (J6) RS232 - Pin-Out

Pin Number	Signal Flow	Signal	Pin Number	Signal Flow	Signal
1	I	DCD	2	I	DSR
3	I	RX	4	O	RTS
5	O	TX	6	I	CTS
7	O	DTR	8	I	RI
9	-	GND	10	-	Not Used

**TABLE 10-1b:** IBM 9-Pin DSUB Standard - Pin-Out

Pin Number	Signal Flow	Signal	Pin Number	Signal Flow	Signal
1	I	DCD	2	I	RX
3	O	TX	4	O	DTR
5	-	GND	6	I	DSR
7	O	RTS	8	I	CTS
9	I	RI	10		

TEKNOR offers a 10-pin header to 9-pin DSUB cable for IBM-AT compatibility. This can be purchased from TEKNOR or a cable can be made with a flat cable, a 10-pin flat cable crimp header and a 9-pin DSUB flat cable crimp connector. The use of Taiwanese adapter cables is not recommended, since the pin-out is often incorrect. The direct crimp design offered by TEKNOR allows the simplest cable assembly. All these cables are available from TEKNOR by contacting the Sales department.

### Serial Port 2 (J7) RS232

The Serial Port 2 can be configured as RS232 or RS485. As a RS232 port, and with the IBM 9-pin DSUB Standard, Serial Port 2 is 100% compatible with the IBM-AT serial port. The following tables show their pin-outs:

**TABLE 10-2a:** Serial Port 2 (J7) RS232 - Pin-Out

Pin Number	Signal Flow	Signal	Pin Number	Signal Flow	Signal
1	I	DCD	2	I	DSR
3	I	RX	4	O	RTS
5	O	TX	6	I	CTS
7	O	DTR	8	I	RI
9	-	GND	10	-	Not Used

**TABLE 10-2b:** IBM 9-Pin DSUB Standard - Pin-Out

Pin Number	Signal Flow	Signal	Pin Number	Signal Flow	Signal
1	I	DCD	2	I	RX
3	O	TX	4	O	DTR
5	-	GND	6	I	DSR
7	O	RTS	8	I	CTS
9	I	RI	10		

TEKNOR offers a 10-pin header to 9-pin DSUB cable for IBM-AT compatibility. This can be purchased from TEKNOR or a cable can be made with a flat cable, a 10-pin flat cable crimp header and a 9-pin DSUB flat cable crimp connector. The use of Taiwanese adapter cables is not recommended, since the pin-out is often incorrect. The direct crimp design offered by TEKNOR allows the simplest cable assembly. All these cables are available from TEKNOR by contacting the Sales department.

### Serial Port 2 (J7) RS485/RS422

If Serial Port 2 is configured for RS485 operation, it can support either full-duplex or party line communication.

**Full Duplex Operation (RS422):** Upon power-up or reset, the COM2 interface circuits are automatically configured for full duplex operation. Pins 3 and 4 of J7 act as the receiver lines and pins 5 and 6 act as the transmitter lines.

**Party Line Operation (RS485):** In order to enable party line operation, the user must first write "1" to bit 3 at I/O address 190H (or at 290H or 390H depending on W9 jumper). This allows the transceiver (pins 3 and 4 of J7) to be controlled by the RTS signal. Upon power-up or reset, the transceiver is by default in "receiver mode" in order to prevent unwanted perturbation on the line.

In party line operation, termination resistors R84 and R85 must be installed only on the boards at both ends of the network.

The following table shows this connector's pin-out:

**TABLE 10-3:** Serial Port 2 (J7) RS485/RS422 - Pin-Out

Pin Number	Signal Flow	Signal	Pin Number	Signal Flow	Signal
1	I	DCD	2	I	DSR
3	I/O	RXD(-)	4	I/O	RXD(+)
5	O	TXD(-)	6	I	TXD(+)
7	O	DTR	8	I	RI
9	-	GND	10	-	Not Used

## 10.01.2 SERIAL PORT JUMPERS

Serial port jumpers and their settings appear below:

- W5, W6, W16 & W17 Serial Port 2 Configuration:
  - Pins 1-2 shorted: RS232. This is the initial setting.
  - Or Pins 2-3 shorted: RS485/RS422.
- W14 Serial Port 2 Configuration:
  - Open: RS232. This is the initial setting.
  - Shorted: RS485.
- W4 RTS2-CTS2 & W15 DSR2-DTR2:
  - W4 and W15 shorted: Loopback, or
  - W4 and W15 open: Normal. This is the initial setting.

For location and settings of jumpers, refer to Section 2 of this manual.

### 10.01.3 SERIAL PORTS SOFTWARE SETUP

#### AMIBIOS Setup

Follow these steps, from the AMIBIOS Setup program's main menu:

- From the Setup window, select the Peripheral icon.
- In the Peripheral Setup screen, the ON BOARD SERIAL PORT 1 option may be set to Auto, Disabled, 3F8h, 2F8h, 3E8h or 2E8h (if one of these is used by SERIAL PORT 2, it will not appear in the scroll list).
- Also in the Peripheral Setup screen, the ON BOARD SERIAL PORT 2 option may be set to Auto, Disabled, 3F8h, 2F8h, 3E8h or 2E8h (if one of these is used by SERIAL PORT 1, it will not appear in the scroll list).

For more detail, refer to Section 15 of this manual.

## **10.02 PARALLEL PORT**

### 10.02.1 MODES

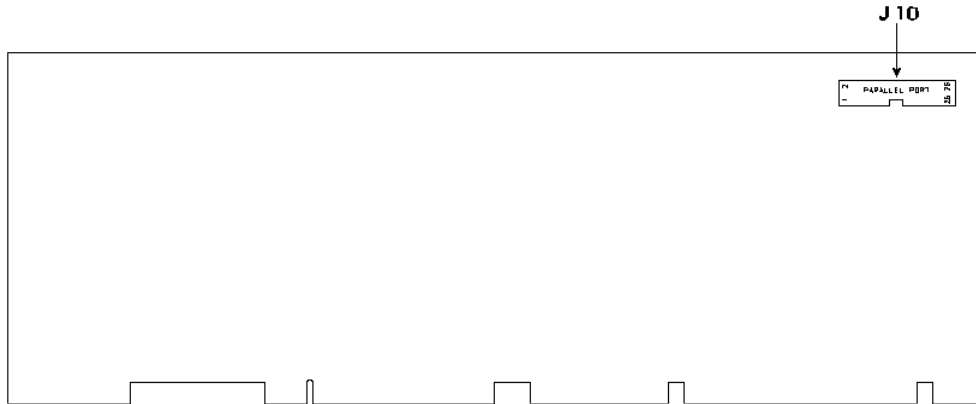
The parallel port is a multi-mode parallel port supporting the following modes:

- Standard Parallel Port (SPP): This mode is IBM XT/AT compatible and PS/2 compatible (bi-directional);
- Enhanced Parallel Port (EPP);
- Extended Capabilities Port (ECP).

## 10.02.2 PARALLEL PORT LOCATION & PIN-OUT

The Parallel Port appears on Diagram 10-2 at J10.

**DIAGRAM 10-2:** Parallel Port Location





The parallel port connector (J10) is a male 26-pin header located at the top right side of the board.

The following table shows the pin-out for this connector when it is in Standard mode:

**TABLE 10-4:** Parallel Port Connector (J10) - Standard Mode

Pin Number	Signal Flow	Signal	Pin Number	Signal Flow	Signal
1	O	STROBE*	2	O	AUTOFD*
3	I/O	D0	4	I	ERROR*
5	I/O	D1	6	O	INIT*
7	I/O	D2	8	O	SELECTIN*
9	I/O	D3	10	-	GND
11	I/O	D4	12	-	GND
13	I/O	D5	14	-	GND
15	I/O	D6	16	-	GND
17	I/O	D7	18	-	GND
19	I	ACK*	20	-	GND
21	I	BUSY	22	-	GND
23	I	PE	24	-	GND
25	I	SELECT	26	-	GND

\* Active low signal

The following table shows the pin-out for this connector when it is in EPP mode:

**TABLE 10-5:** Parallel Port Connector (J10) - EPP Mode

Pin Number	Signal Flow	Signal	Pin Number	Signal Flow	Signal
1	O	WRITE*	2	O	DATASTB*
3	I/O	D0	4	-	Not Used
5	I/O	D1	6	-	Not Used
7	I/O	D2	8	O	ADDRSTRB*
9	I/O	D3	10	-	GND
11	I/O	D4	12	-	GND
13	I/O	D5	14	-	GND
15	I/O	D6	16	-	GND
17	I/O	D7	18	-	GND
19	I	INTR	20	-	GND
21	I	WAIT*	22	-	GND
23	-	Not Used	24	-	GND
25	-	Not Used	26	-	GND

\* Active low signal

The following table shows the pin-out for this connector when it is in ECP mode:

**TABLE 10-6:** Parallel Port Connector (J10) - ECP Mode

Pin Number	Signal Flow	Signal	Pin Number	Signal Flow	Signal
1	O	STROBE*	2	O	AUTOFD*, HOSTACK <sup>2</sup>
3	I/O	D0	4	I	FAULT* <sup>1</sup> , PERIPHRQST* <sup>2</sup>
5	I/O	D1	6	O	INIT* <sup>1</sup> , REVERSERQST* <sup>2</sup>
7	I/O	D2	8	O	SELECTIN* <sup>1,2</sup>
9	I/O	D3	10	-	GND
11	I/O	D4	12	-	GND
13	I/O	D5	14	-	GND
15	I/O	D6	16	-	GND
17	I/O	D7	18	-	GND
19	I	ACK*	20	-	GND
21	I	BUSY, PERIPHACK <sup>2</sup>	22	-	GND
23	I	PERROR, ACKREVERSE <sup>2</sup>	24	-	GND
25	I	SELECT	26	-	GND

\* Active low signal

<sup>1</sup> Compatible Mode

<sup>2</sup> High Speed Mode

Note: For more information on the ECP protocol, please refer to the Extended Capabilities Port Protocol and ISA Interface Standard (available from Microsoft Corporation) or contact our Technical Support department.

### 10.02.3 PARALLEL PORT SOFTWARE SETUP

#### AMIBIOS Setup

Follow these steps, from the AMIBIOS Setup program's main menu:

- From the Setup window, select the Peripheral icon.
- In the Peripheral Setup screen, the ONBOARD PARALLEL PORT option may be set to Auto, Disabled, 278h, 3BCh or 378h.
- Also in the Peripheral Setup screen, the PARALLEL PORT MODE option may be set to Normal, EPP (Enhanced Parallel Port) and Extended (ECP - Extended Capabilities Port).

For more detail on AMIBIOS, refer to Section 15 of this manual.

## **11 SCSI**

### **11.01 INSTALLING SCSI DEVICES**

The SCSI Controller is optional equipment on the TEK933 board.

The TEK933 board provides an interface between a host or peripheral device, and the Small Computer System Interface (SCSI) bus. An impressive combination of hardware and firmware features makes this a truly powerful card.

The TEK933 uses the Symbios 53C810 SCSI II/PCI Controller. It provides Bus Master support and a burst data transfer rate of 10MB/second in synchronous mode, at a clock rate of 40MHz, and 5MB/second in asynchronous mode. Built using proven CMOS low-power technology, the board also integrates the SCSIII standard command set.

The TEK933 SCSI can co-exist with other hard disk/controller combinations: such as ST-506, RLL, ESDI and IDE.

### 11.01.1 INSTALLING A FIXED SCSI HARD DISK

This section will explain how to go about installing a fixed SCSI Hard Disk on your system. No additional hardware or drivers are necessary if no more than two IDE/SCSI hard disks will be present in your system.

To install your fixed SCSI hard disk, these steps must be followed:

#### 1 - VIP-UP Setup

It is important that you configure your TEK933 properly with the VIP-UP software utility prior to physically installing your SCSI hard disk. The On Board SCSI Controller/BIOS option of the VIP-UP screen must be set at Enabled. When done, update your VIP-UP Setup by pressing the F10 key.

You should not "install" your SCSI hard disk type in AMIBIOS Setup (only your IDE hard disk).

#### 2 - Jumpers (Power Off)

Now power off your computer. The TEK933 board's initial jumper settings should be kept in most cases, unless there is a conflict with other devices you have installed.

- W18: Sets up the SCSI Termination Control:
  - Pins 1-2 shorted: Controlled by software, or
  - Pins 2-3 shorted: Controlled by hardware (board is terminated):  
This is the initial setting, or
  - No jumper: Disabled by software.

Jumper locations and settings appear in Section 2 of this manual.

### 3 - Connect SCSI Cable (Power Off)

Make certain that both ends of the SCSI cable are terminated and that all devices in between the ends are non-terminated. The SCSI connector on the TEK933 board is terminated.

Attach one end of the SCSI cable to the J2 SCSI 50-pin connector. Make sure line 1 of the cable is matched with pin 1 of connector J2.

Attach the other end to your SCSI device, making sure line 1 is matched with pin 1 on your device.

You must also install a cable from your power supply to your SCSI device.

### 4 - Follow Specific Device Installation Instructions (Power On)

Follow installation instructions provided with your SCSI peripheral device to install it in the host.

☞ **Each device being installed must be assigned a unique identifier called a SCSI Target ID. The lower the ID, the lower the priority level of the device in the SCSI subsystem. The host adapter is usually assigned the highest priority level (i.e. 7). Table 11-1 lists common SCSI Target IDs.**

**TABLE 11-1:** Common SCSI Target IDs

SCSI Device	Commonly Used IDs
Host Adapter	7
Hard Disks	0,1,2,3
CD-ROM	4,5
Tape drive	5,6

### 11.01.2 INSTALLING OTHER SCSI DEVICES

To install any of the following: CD-ROM, Magneto-Optical/Removable Disk Drive, Tape Drive, Write Once Read Many (WORM) and scanners, please use the SCSI diskette that you received with your TEK933. A special utility will install all the necessary drivers.

### 11.01.3 SCSI CONNECTOR

**TABLE 11-2: SCSI Connector (J2) - Pin-Out**

Pin Number	Signal	Pin Number	Signal
1	GND	2	SCSI D0
3	GND	4	SCSI D1
5	GND	6	SCSI D2
7	GND	8	SCSI D3
9	GND	10	SCSI D4
11	GND	12	SCSI D5
13	GND	14	SCSI D6
15	GND	16	SCSI D7
17	GND	18	SCSI DP*
19	GND	20	GND
21	GND	22	GND
23	GND	24	GND
25	Not Used	26	Term Power
27	GND	28	GND
29	GND	30	GND
31	GND	32	ATN*
33	GND	34	GND
35	GND	36	BSY*
37	GND	38	ACK*
39	GND	40	RESET*
41	GND	42	MSG*
43	GND	44	SEL*
45	GND	46	C/D*
47	GND	48	REQ*
49	GND	50	I/O*

\* Active low signal



## **12 ETHERNET**

### **12.01 ETHERNET FEATURES**

The onboard Ethernet controller and port has these features:

- Supports IEEE 802.3 / ANSI 8802-3 and Ethernet standards.
- Individual 136-byte transmit and 128-byte receive FIFOs optimize system overhead, providing sufficient latency during packet transmission and reception, and minimizing intervention during normal network error recovery.
- Supports Microsoft's Plug and Play System configuration for jumperless designs. Information stored in the serial EEPROM is used to identify the card and to describe the system resources required by the Plug and Play card, such as I/O space, Memory space, IRQs and DMA channels. This information is stored in a standardized read-only format.

## **12.02 SETTING UP ETHERNET**

### **12.02.1 CABLING**

The TEK933 is configured with either the Ethernet 10 Base-T or 10 Base-2 interface. The 10 Base-T interface uses UTP (Unshielded Twisted Pair) cables, category 5, 4 or 3 (5 is better). The 10 Base-2 interface uses Thin Ethernet coaxial cables (RG-58). The impedance is 50 ohms.

### **12.02.2 CONFIGURATION**

The Ethernet controller on the TEK933 is Plug and Play, therefore no manual configuration is normally required. A diskette entitled "Network Drivers for AM79C961" is included with the Ethernet option. This diskette contains several operating system network drivers. You must refer to the READ\_NET.TXT (ASCII) or READ\_NET.DOC (WORD 6.0) file, also on the diskette, for instructions on installing the drivers.

Once the proper Ethernet driver is installed, the onboard Plug and Play BIOS and the driver automatically allocates resources - I/O addresses, IRQ and DMA channels - to the Ethernet device.

In some cases, it might be absolutely necessary to manually configure the Ethernet Controller. This is the case when several ISA cards (non Plug and Play) use resources that might be allocated to the Ethernet controller. A special utility called the PCNETCFG.EXE was designed for such situations; it will allow you to manually configure the Ethernet controller.

For the PCNETCFG.EXE utility, other operating system drivers and installation instructions, or for more information, contact TEKNOR's Technical Support department.

### 12.03 ETHERNET CONNECTORS

The pin-out for the 10 Base-T connector appears in Table 12-1.

The pin-out for the 10 Base-2 connector appears in Table 12-2.

**TABLE 12-1:** Ethernet 10 Base-T RJ45 Connector (J16) - Pin-Out

Pin Number	Signal Flow	Signal	Pin Number	Signal Flow	Signal
1	O	TD+	2	O	TD-
3	I/O	RD+	4	-	Not Used
5	-	Not Used	6	I	RD-
7	-	Not Used	8	-	Not Used

**TABLE 12-2:** Ethernet 10 Base-2  
BNC Connector (J23) - Pin-Out

Pin Number	Signal Name
Center Conductor	Signal
Shield	GND

NOTE: The Ethernet 10 Base-2 Connector (J23) is a standard BNC connector.

## **13 VIDEO**

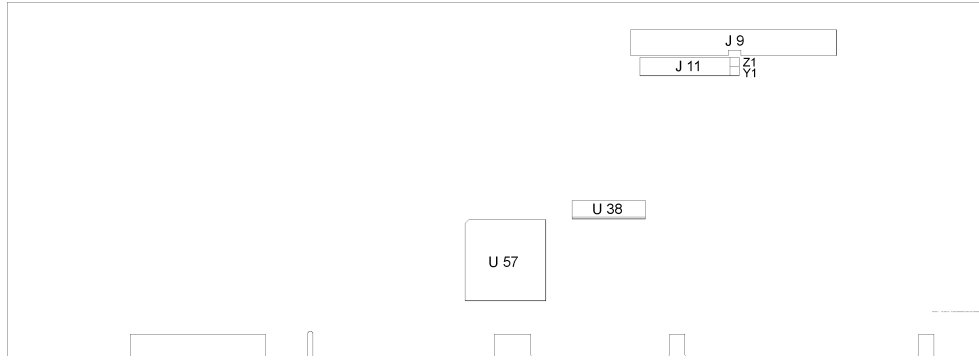
### **13.01 LOCATION OF VIDEO COMPONENTS**

The TEK933 video system includes a local bus Flat Panel/CRT video controller, 1MB of video memory (DRAM) and a video feature connector for video overlay and color keying.

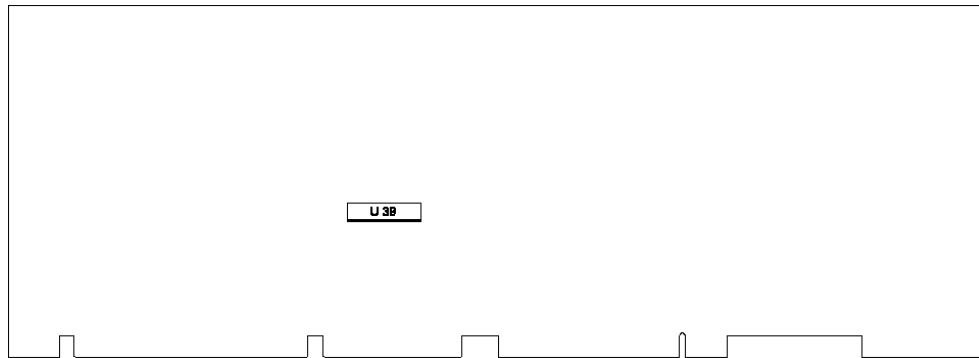
Video components appear on Diagram 13-1 and 13-2 (on the following page) as follows:

- Flat Panel / CRT VGA Controller at U57;
- Video Memory (1MB DRAM) at U38 and U39;
- Flat Panel Connector at J9;
- Video Feature Connector at J11.

**DIAGRAM 13-1:** Video Components Location (Top of Board)



**DIAGRAM 13-2:** Video Components Location (Bottom of Board)



## **13.02 FLAT PANEL / CRT VGA CONTROLLER**

The TEK933's Flat Panel / CRT VGA controller is a single-chip video controller from Cirrus Logic<sup>®</sup> (CL-GD7543). The controller is fully compatible with the IBM<sup>™</sup> VGA standard at the hardware and BIOS levels. Other features of the video chip include BitBLT (bit block transfer), GUI acceleration, true-color capability and power management support.

### **13.02.1 FLAT PANEL SUPPORT**

The video controller supports panels with resolution up to 800 x 600. It supports monochrome and color Single-Panel/Single-Drive, Dual-Panel/Dual-Drive, STN and TFT LCD, and EL panels.

### **13.02.2 CRT SUPPORT**

The video controller supports CRT terminals with high resolution of 1024 x 768 (65,536 colors) and 1280 x 1024 (256 colors). It is compatible with CGA, EGA, Hercules, MDA, VGA and SVGA monitors.

### **13.02.3 DISABLING VIDEO DISPLAY**

The video controller can be disabled by shorting pins 7 and 8 on the W8 jumper. See Section 2 for jumper location and settings.

This feature is useful when an external video card is required for testing or other purposes.

### 13.03 CONNECTING CRT VIDEO DISPLAY

Connecting CRT video to the TEK933 is simple. Merely connect the standard VGA DB15 male connector to the board's J15 high density, right angle, female connector. See Diagram 13-1 for the location of J15.

#### 13.03.1 SVGA CONNECTOR (J15)

The VGA connector's pin-out appears in Table 13-1.

**TABLE 13-1:** VGA Connector (J15) - Pin-Out

Pin Number	Signal	Pin Number	Signal	Pin Number	Signal
1	RED	6	ANALOG GND	11	Not Used
2	GREEN	7	ANALOG GND	12	Not Used
3	BLUE	8	ANALOG GND	13	HSYNC
4	NotUsed	9	Not Used	14	VSYNC
5	GND	10	GND	15	Not Used

## 13.04 CONNECTING FLAT PANEL VIDEO DISPLAY

### 13.04.1 FLAT PANEL CONNECTOR (J9)

The Flat Panel connector's pin-out appears in Table 13-2. See Diagram 13-1 for the location of J9.

**TABLE 13-2:** Flat Panel Connector (J9) - Pin-Out

Pin Number	Signal	Pin Number	Signal
1	FP4	2	FP5
3	FP6	4	FP7
5	FP12	6	FP13
7	FP14	8	FP15
9	FP19	10	FP18
11	FP11	12	FP10
13	FP23	14	FP22
15	FP21	16	FP20
17	GND	18	FPVDCLK
19	GND	20	FP9
21	GND	22	LFS
23	FP3 (MOD)	24	FP0
25	GND	26	FPDE
27	GND	28	GND
29	FP8	30	GP0
31	GP1	32	GND
33	FPBL	34	GND
35	LLCLK	36	GND
37	FPVEE	38	FPVCC
39	FP2	40	GP2
41	STANDBY*	42	FP16
43	FP1	44	FP17
45	Not Used	46	Not Used
47	VCC (+5V)	48	VCC (+5V)
49	+12V	50	+12V

\* Active low signal



### 13.04.2 FLAT PANEL INSTALLATION

The myriad of Flat Panel displays available makes it virtually impossible for us to show every type of configuration that exists. For your convenience, we have published the **TEK933 FLAT PANEL CONFIGURATION GUIDE**. This handy manual charts out the cabling, jumper settings, and other special requirements for some of the most popular displays.

The name of the Flat Panel BIOS file (.BFP extension) that you must use to update the Flash EPROM BIOS is also included in this guide; see Section 17 to learn how to perform a VGA BIOS file update with the UBIOS software.

Most Flat Panel displays require a special adapter board or cabling between them and the TEK933. Please contact our Sales or Technical Support department for more information on Flat Panel applications.

### 13.05 VIDEO FEATURE CONNECTOR (J11)

The Video Feature Connector (also called a Dynamic Overlay Port) at J11 is a VESA/VGA pass-through connector. It directly supports the 8-bit mode; the connector also supports the 16-bit mode when using an external data multiplexer.

Through the Video Feature Connector, the TEK933 makes possible dynamic overlay. In dynamic overlay configurations, the video signal can be overlaid on a pixel basis. This makes it possible to overlay a portion of the frame and mix the signal with externally generated video signal. Both the video source and the choice of pixels to overlay can be changed dynamically.

Jumpers W7 and W23 are used for enabling or disabling the Video Feature Connector:

- Enable: Open W7 and short W23;
- Disable: Short W7 and open W23 (This is the initial setting).

Note: When the video feature is enabled, certain restrictions apply to the Flat Panel connector. Contact Technical Support for more information.

The connector's pin-out is described below. See Diagram 13-1 for the location of J11.

**TABLE 13-3:** Video Feature Connector (J11) - Pin-Out

I/O Pin	Signal Name	I/O Pin	Signal Name
Y1	FCP0	Z1	GND
Y2	FCP1	Z2	GND
Y3	FCP2	Z3	GND
Y4	FCP3	Z4	FCEVIDEO*
Y5	FCP4	Z5	FCESYNC*
Y6	FCP5	Z6	Not Used
Y7	FCP6	Z7	Not Used
Y8	FCP7	Z8	GND
Y9	FCCLK	Z9	GND
Y10	FCBLANK*	Z10	GND
Y11	FCHSYNC	Z11	GND
Y12	FCVSYNC	Z12	FCVCLK
Y13	GND	Z13	OVRW*

\* Active low signal

## **14 POWER MANAGEMENT**

### **14.01 POWER MANAGEMENT MODES**

The TEK933 supports a very flexible and powerful power management scheme. The System Controller provides progressively higher levels of power conservation whenever the system is idle through the following special power saving modes: Sleep Mode and Suspend Mode. These modes are fully programmable through the AMIBIOS Setup Program (see Section 15). In general, each progressive level of power management is entered when inactivity is detected by the System Controller which monitors activity from the Keyboard, Video, Serial and Parallel I/O, and the Hard and Floppy Drives. The timeouts which are used to enter into Sleep Mode and then Suspend Mode are programmable via the AMIBIOS Power Management Setup Screen. Each mode is described below.

#### **14.01.1 SLEEP MODE**

The Sleep Mode is the System Controller's first level of power conservation. In this mode, some clocks may be reduced in frequency or stopped.

#### **14.01.2 SUSPEND MODE**

The Suspend Mode is the System Controller's second level of power conservation. In this mode, a special BIOS routine is invoked to save the current state of the system for complete restoration at some later time. Most of the system components and peripherals can be shut down for optimum power conservation.

## **14.02 RESET CIRCUIT**

### **14.02.1 EXTERNAL RESET CIRCUIT SWITCH**

The TEK933 can be reset by activating an external reset switch.

This switch should be connected between pin 13 (PBRESET) and pin 14 (GND) on the Multi-Function Connector (J5).

This provides an easy and effective way of resetting the system.

See Section 6.11 for more information.

### **14.02.2 ONBOARD POWER DETECTION**

An onboard device which is part of the reset circuit constantly monitors the voltage which powers the board. Normally, the board is powered with 5V. If the supply voltage drops below 4.65V (a typical threshold), the onboard circuitry will reset the board and the system. This reset has the same effect on the system as the reset button.

### 14.03 POWER FAIL DETECTION CIRCUIT

The Power Failure Detector always monitors:

- The backup battery to warn of a low battery condition, and
- The +5V power supply to detect when it falls below 4.75V.

If either of the two above conditions occur, the PFO (Power Fail Output signal) goes low. In the case of the +5V power supply, a reset will result as explained in the previous section (14.02.2). In the case of the low battery, what happens will depend on the setting of the W13 jumper and user-defined algorithm.

The W13 jumper, when shorted, will generate a NMI (Non Maskable Interrupt), through the IOCHK\* line, when the PFO goes low. In turn, this NMI may be serviced by an interrupt handler to locate the source and notify the user or the system.

If the W13 jumper is left open, no NMI is generated, however an algorithm could be used to detect a low battery condition and respond accordingly.

A low battery condition is detected, in any case, by polling bit 3 at TEKNOR's I/O base address register (190H, 290H or 390H, depending on W9 jumper setting): If this bit reads "1", then the battery voltage is good; if it reads "0", then it is in a low condition (below 2.9V, typical).

Jumper locations and settings are illustrated in Section 2.

#### 14.04 WATCHDOG TIMER

The Watchdog Timer is extremely useful in embedded systems where human supervision is not required. Following a reset, the Watchdog is always disabled. The Watchdog is enabled once you write "1" in bit "0" at address 190H the first time (or at 290H or 390H depending on the W9 jumper setting). When enabled, the microprocessor must refresh the Watchdog. This is done by writing alternatively "0" and "1" to bit 1 at address 190H (or at 290H or 390H), once every 1.6 seconds to verify proper software execution.

If a hardware or software failure occurs such that the Watchdog is not refreshed, a reset pulse is generated by the Watchdog to restart the processor.

☞ **The user program must provide the first access to address 190H (or at 290H or 390H depending on the W9 jumper setting), and must also include the refresh routine. In addition, be certain to keep a mirror image of register 190H (or 290H or 390H) when programming it. This is necessary since the register is a write-only user register and, as a result, is not used by the system BIOS.**

**TABLE 14-1:** Watchdog Timer Register

ADDRESS	REGISTER
190H, 290H OR 390H: Bit 0                      Read/Write	Watchdog enable
190H, 290H OR 390H: Bit 1                      Read/Write	Watchdog refresh

Jumper W26 must be installed to permit activation of the Watchdog. If jumper W26 is removed, the Watchdog is disabled.

**PART THREE**  
**SOFTWARE REFERENCE**

15 AMIBIOS SETUP

16 VIP-UP SETUP

17 UPDATING BIOS WITH UBIOS

18 VT100 MODE

## **15 AMIBIOS SETUP**

The TEK933 is fully software configurable. The setup programs allow for minimal hardware configuration.

The VIP-UP program - TEKNOR's own Setup program for enabling / disabling / relocating various hardware features - is explained in Section 16.

The AMIBIOS Setup program which is used to change operating parameters is explained in this section.

### **15.01 ACCESSING AMIBIOS SETUP PROGRAM**

The TEK933 uses the AMIBIOS Setup program, a setup utility in ROM that is accessed by pressing the DELETE key at the appropriate time during system boot. This utility is used to set configuration data in CMOS RAM.

The system BIOS (Basic Input Output System) provides an interface between the operating system and the hardware of the TEK933 single-board computer. The interface provided by AMIBIOS is 100% IBM AT compatible. All functions accept similar inputs as IBM and provide the same results, although the program code itself is different.

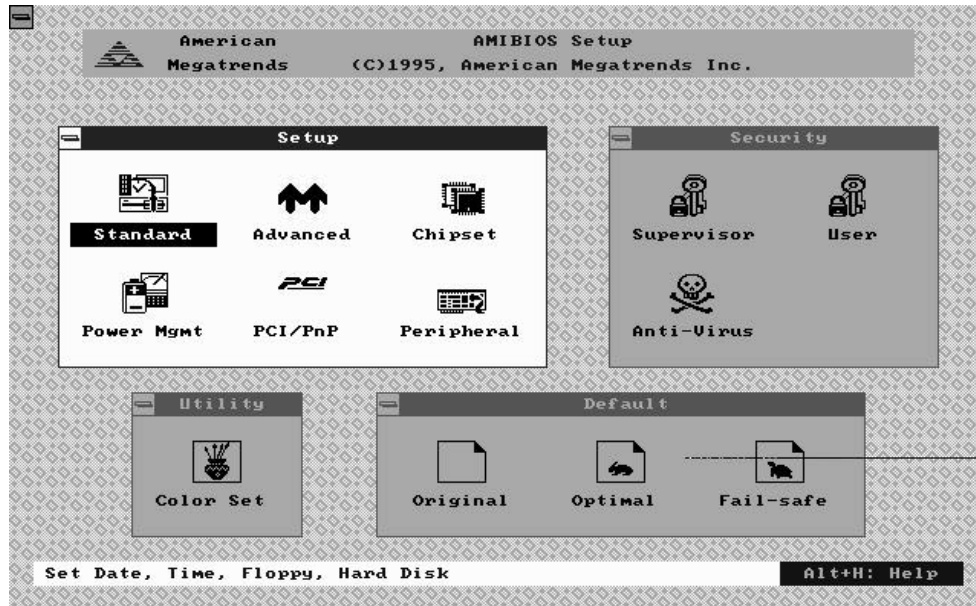
To run the AMIBIOS Setup program incorporated in the ROM BIOS:

- Turn on or reboot the system.
- Hit the DELETE key before or when the message - "Hit <DEL> if you want to run SETUP" appears near the top of the screen (DELETE will work, even if the message display is disabled in AMIBIOS SETUP).
- The main menu appears on the screen.



## 15.02 AMIBIOS SETUP MAIN MENU

An example of the main menu screen appears below:



As shown in the diagram above, the main menu is composed of four windows:

- Setup (explained in section 15.04)
- Utility (section 15.05)
- Security (section 15.06)
- Default (section 15.07).

By default, the Setup window is highlighted (as shown on the screen above) when the main menu is called up; to highlight the other windows, press the TAB key on the keyboard.

- ☞ **Press TAB to highlight the desired window (Setup, Utility, Security, or Default) and to access available options in that window.**

## 15.03 MAKING SELECTIONS, SAVING CONFIGURATIONS & EXITING AMIBIOS SETUP

### 15.03.1 MAKING SELECTIONS

Each of the windows displayed in the main menu screen contains icons (small drawings under which an identifying label appears). For example, the Setup window has the following icons and labels: Standard, Advanced, Chipset, Power Mgmt, PCI/PnP and Peripheral. Each of these icons corresponds to various setups available within AMIBIOS Setup, i.e. the Standard Setup, the Advanced Setup, the Chipset Setup, the Power Management Setup, the PCI/Plug and Play Setup and the Peripheral Setup. Selecting one of these icons gives access to the corresponding Setup and its options.

To select an icon within a window, you must press one of the arrow keys on the keyboard until the desired icon is highlighted, and then press the ENTER key (or if a PS/2 mouse was detected, move the arrow cursor over the desired icon, and click the left mouse button). This method of selection basically applies for opening windows, a scroll list of options, and option pop-ups.

When a value needs to be entered, a window appears which resembles a keyboard indicating that a value needs to be entered using the keyboard; as you type, the characters are displayed (in the case of a password entry, "\*" is displayed for each character entered); to accept the value you typed, press the ENTER key.

When an option value needs to be modified, select the option from the control list: a pop-up window appears next to the displayed value. Press the + or - key on the keyboard or numeric keypad to display other available values, then press ENTER to accept this value.

- ☞ **To select an icon or an option, first use one of the arrow keys to highlight the desired icon or option, then press the ENTER key (or click the mouse over the desired selection).**
- ☞ **To modify an option value, use the option pop-up window which appears on the screen when the option is selected; pressing the + or - key toggles the display among the available values. When the desired value is displayed, press ENTER or click the mouse to accept that value.**
- ☞ **In the case of values which must be typed in at the keyboard, enter the desired value then press the ENTER key to accept it.**

The windows in the program have layers, like boxes inside boxes. Selecting an icon, may display another window with icons; in turn, clicking one of these icons can display a window which contains a list of options. To return to a previous window, you press the ESC key on the keyboard. If you press the ESC key from the main menu screen, an EXIT SETUP window appears, which is explained in the next section.

☞ **The ESC key is used to close the current window and move to the previous window. If you are in the main menu screen, pressing the ESC key displays the EXIT SETUP window to allow you to save and exit the AMIBIOS Setup program.**

### 15.03.2 SAVING CONFIGURATIONS & EXITING AMIBIOS SETUP

The EXIT SETUP window displays the following options:

- Save changes and Exit
- Do not save changes and Exit
- Continue

Each is explained below:

#### Save changes and Exit

After having modified the AMIBIOS Setup, you can save the configuration in CMOS RAM, by selecting this option. After the information is saved, the computer is automatically rebooted. This option will not change the values saved in Flash EPROM. To update the values in Flash, enter the VIP-UP program and perform a save (F10).

☞ **It is highly recommended that the system be turned off after a configuration has been saved. Some hardware may only be configured during a power-up.**

#### Do not save changes and Exit

This option is used to exit AMIBIOS Setup without saving the configuration to CMOS RAM. After the information is saved, the computer is automatically rebooted.

### Continue

To return to the main menu without saving or exiting, select this option.

☞ **To save changes and write the new configuration to CMOS RAM, press ESC from the main menu and select the "Save changes and Exit" option.**

The four windows of the main menu will now be described in the remainder of Section 15.

## 15.04 SETUP WINDOW

### 15.04.1 STANDARD SETUP

This part of the setup allows you to set the time, date, hard disk type, types of floppy drives.

The Standard Setup screen displays seven icons as follows:

**Pri Master    Sec Master**  
**Pri Slave    Sec Slave**

There can be two IDE controllers defined on the TEK933 board (Primary or Secondary), each can have two disks: Master Disk (bootable) or Slave Disk. Select one of these hard disk drive icons. Select the option TYPE: an options list displays all valid disk drive types. Select the correct type and press ENTER. If the hard disk drive is an IDE drive, the AUTO option automatically finds all of the IDE drive parameters for that hard disk.

The displayed parameters are stored in the user defined drive TYPE "USER".

☞ **It is possible that the parameters provided do not match the ones found in your drive's literature. This should not be considered an error. As matter of fact, different combinations of heads, cylinders and sectors that match the disk's capacity in MB will work when formatting an IDE hard drive. But if the disk is already formatted, it is not possible to use different parameters than the ones that were used when the drive was originally formatted.**

You can also enter the hard disk drive parameters (Cylinders, Heads, Write Precompensation, Sectors, and Capacity) by selecting the option USER of the TYPE options list.

### **Date/Time**

The current values for each category are displayed. Enter new values through the keyboard.

### **Floppy A** **Floppy B**

The settings are: 360KB 5¼ inch, 1.2MB 5¼ inch, 720KB 3½ inch, 1.44MB 3½ inch, 2.88MB 3½ inch, or not installed.

#### 15.04.2 ADVANCED SETUP

This part of the setup handles options and features such as boot sequence, NUM LOCK, password checking, shadowing, ...

Whenever you are not sure about a certain setting, you may refer to the list of default values. The list of defaults is provided in the event that a value has been changed and one wishes to set this option to its original value. Loading the Optimal or Fail-Safe defaults will affect all the options and will reset options previously altered.

The Fail-Safe default settings consist of the safest set of parameters. Use them if the system is behaving erratically. They should always work but do not provide optimal system performance.

The Optimal default values provide optimum performance settings for all devices and system features.

The scroll list displays these options:

<b>OPTIONS</b>	<b>FAIL-SAFE DEFAULTS</b>	<b>OPTIMAL DEFAULTS</b>
Quick boot	Disabled	Enabled
BootUp Sequence	C:.,A:.,CDROM	C:.,A:.,CDROM
BootUP Num-Lock	Off	Off
Floppy Drive Swap	Disabled	Disabled
Mouse Support	Enabled	Enabled
Primary Display	VGA/EGA	VGA/EGA
Password Check	Setup	Setup
OS/2 Compatible Mode	Disabled	Disabled
Hit 'DEL' Message Display	Enabled	Enabled
Internal Cache	Writeback	Writeback
External Cache	Writeback	Writeback
System BIOS Cacheable	Disabled	Enabled
C000, 16k Shadow	Enabled	Cached
C400, 16k Shadow	Enabled	Cached
C800, 16k Shadow	Disabled	Disabled
CC00, 16k Shadow	Disabled	Disabled
D000, 16k Shadow	Disabled	Disabled
D400, 16k Shadow	Disabled	Disabled
D800, 16k Shadow	Disabled	Disabled
DC00, 16k Shadow	Disabled	Disabled

The various options in the ADVANCED SETUP are described below.

#### QUICK BOOT

This option enables AMIBIOS to boot faster than usual (from power on to adaptor ROM initialization in less than five seconds). It also supports the Instant On feature as specified in the Intel power management specifications. When Quick Boot is enabled, AMIBIOS does not test system memory above 1MB and does not wait up to 40 seconds for a READY signal from the IDE hard drive (as a result, AMIBIOS does not configure that drive if a READY signal is not received immediately).

#### BOOTUP SEQUENCE

This option specifies the boot sequence for drive A:, C:, CDROM after AMIBIOS POST completes and attempts to boot DOS. The settings are C:, A:, CDROM or A:, C:, CDROM or CDROM, C:, A:. When booting from the CDROM drive, the CDROM will behave like drive A: if it has a floppy boot image. The CDROM drive will now become drive A: and the first floppy drive will become drive B:. On the other hand, the CDROM will behave like a hard drive if the CDROM has a hard disk boot image. The CDROM drive will now become drive C: and all other hard drives will be shifted one letter (the hard disk drive becomes drive D:).

#### BOOTUP NUM-LOCK

If this option is set to Off, the NUM LOCK key on the keyboard is turned off when the system is powered on; you can use the →, ←, ↑, ↓ keys on both the numeric keypad and the keyboard.

#### FLOPPY DRIVE SWAP

By enabling this option, floppy drive A: becomes drive B:, and drive B: (if present) becomes drive A:. Thus you are allowed to boot from drive B:.

#### MOUSE SUPPORT

This option, when set to Enabled, specifies that a PS/2 type mouse is supported.



## PRIMARY DISPLAY

This option specifies the type of display adapter card installed in the system. The settings are: Absent, VGA/EGA, CGA 40x25, CGA 80x25, or MONO.

## PASSWORD CHECK

This option enables a password check every time the system boots or if AMIBIOS Setup is executed. If Always is chosen, a user password prompt appears every time the computer is turned on. If Setup is chosen, the password prompt appears if AMIBIOS is executed. The password feature is disabled by default but can be enabled by using the PASSWORD option for the first time. For more information on this option, see section 15.06 SECURITY WINDOW (PASSWORD).

## OS/2 COMPATIBLE MODE

When there is more than 16MB system memory and one wishes to boot with OS2 operating system, this option must be set to Enabled.

## HIT 'DEL' MESSAGE DISPLAY

Disabling this option will prevent the "Hit <DEL> if you want to run Setup" message from appearing when the system boots.

## INTERNAL CACHE

With this option you may specify the caching algorithm used for Internal Cache. The settings are : Disabled, WriteBack or WriteThru.

☞ **Ensure that the Internal Cache setting corresponds with the W1 jumper setting (First-level Cache: Write-Back or Write-Through).**

## EXTERNAL CACHE

With this option you may specify the caching algorithm used for External Cache. The settings are : Disabled, WriteBack or WriteThru. When Internal Cache option is set to Disabled, External Cache is Disabled; when Internal Cache is set to WriteThru, External Cache cannot be set to WriteBack.

## SYSTEM BIOS CACHEABLE

When enabled, the contents of F0000h system memory segment can be read from or written to External Cache.

<ADDRESS>, 16K SHADOW

These options enable shadowing of the contents of the ROM area beginning at the address named in the option title. For example, the C800, 16k Shadow option enables shadowing of the contents of ROM from C8000h - CBFFFh to RAM.

☞ **Not all BIOS can be shadowed. In some cases, it can result in erratic operation. For example, if the expansion board has built-in “scratchpad memory” which is used internally, shadowing may cause unpredictable results. In particular, the TEKNOR BIOS Extension and the Flash Window must not be shadowed.**

### 15.04.3 CHIPSET SETUP

This part of the setup allows you to define chipset-specific options and features.

Whenever you are not sure about a certain setting, you may refer to the list of default values. The list of defaults is provided in the event that a value has been changed and one wishes to set this option to its original value. Loading the Optimal or Fail-Safe defaults will affect all the options and will reset options previously altered.

The Fail-Safe default settings consist of the safest set of parameters. Use them if the system is behaving erratically. They should always work but do not provide optimal system performance.

The Optimal default values provide optimum performance settings for all devices and system features.

☞ **These parameters have been provided to give control over the system. However, the values for these options should be changed only if the user has a full understanding of the timing relationships involved.**

The scroll list displays these options:

<b>OPTIONS</b>	<b>FAIL-SAFE DEFAULTS</b>	<b>OPTIMAL DEFAULTS</b>
ISA Command Delay	Normal	Normal
IO Recovery Time	Enabled	Disabled
Decoupled Refresh	Disabled	Enabled
DMA Clock	Slow	Slow
ISA Clock	Auto	Auto
Bank0 DRAM Type	Standard	Standard
Bank1 DRAM Type	Standard	Standard
CAS Before RAS Refresh	Enabled	Enabled
Delay CAS by 1/2 Clock	Disabled	Disabled
DRAM Starts at	T2	T2
DRAM Post Write	Disabled	Disabled
Concurrent Writeback	Disabled	Disabled
Single Write Posted	Disabled	Enabled
Force RAS Pre-charge	Enabled	Enabled
CAS Pre-charge 2T	Disabled	Disabled
RAS Pre-charge 2T	Enabled	Enabled
Delay CAS by 1/2 Clock	Disabled	Disabled
DRAM Timing	Medium	Medium

Memory Hole at 15MB Add	Disabled	Disabled
Non-Cache Block1 Size	Disabled	Disabled
Non-Cache Block1 Base	Disabled	Disabled
Non-Cache Block2 Size	Disabled	Disabled
Non-Cache Block2 Base	Disabled	Disabled
Cache Timing	Normal	Normal

The various options in the CHIPSET SETUP are described below.

#### ISA COMMAND DELAY

This option specifies a delay for the insertion of ISA commands so that devices can have more address setup time. The settings are Normal and Extra.

#### IO RECOVERY TIME

This option enables a delay period between consecutive ISA I/O cycle.

#### DECOUPLED REFRESH

By enabling this option, the system allows onboard DRAM operations to continue before ISA refresh is complete.

#### DMA CLOCK

This option specifies the speed of the DMA clock. The settings are Slow (half ISA bus clock speed) and Fast (ISA bus clock speed).

#### ISA CLOCK

This option sets the speed of the ISA bus clock (SYSCLK) signal, which must be set to approximately 8MHz. The default Auto setting automatically sets SYSCLK to 8MHz. SYSCLK can also be manually set to 7.159 MHz.

#### MEMORY HOLE AT 15MB ADD

This option enables the reserving of a 1MB memory region (from 15MB to 16MB) that can only be addressed on the ISA bus.

#### NON-CACHE BLOCK1 SIZE

This option and the following option, Non-Cache Block1 Base, define the size of a region of memory, Block-1, whose content cannot be read from or written to Cache memory. The settings are Disabled, 64KB, 128KB, 256KB, 512KB, 1MB, 2MB and 4MB.

#### NON-CACHE BLOCK1 BASE

This option and the preceding option, Non-Cache Block1 Size, define the base address or starting point of a region of memory, Block-1, whose content cannot be read from or written to Cache memory. The base address changes in increments equal to the corresponding Non-Cache Block1 Size. If the setting of the Non-Cache Block1 Size option is Disabled, this option will not be available.

#### NON-CACHE BLOCK2 SIZE

This option and the following option, Non-Cache Block2 Base, define the size of a region of memory, Block-2, whose content cannot be read from or written to Cache memory. The settings are Disabled, 64KB, 128KB, 256KB, 512KB, 1MB, 2MB and 4MB.

#### NON-CACHE BLOCK2 BASE

This option and the preceding option, Non-Cache Block2 Size, define the base address or starting point of a region of memory, Block-2, whose content cannot be read from or written to Cache memory. The base address changes in increments equal to the corresponding Non-Cache Block2 Size. If the setting of the Non-Cache Block2 Size option is Disabled, this option will not be available.

#### CACHE TIMING

This option specifies the Cache memory access cycle. It should be set at Normal when the CPU/Bus clock is 60 or 66 MHz. If the CPU/Bus clock is 50MHz, this option should be set at Medium. The settings are Normal, Medium, Fast (not supported, reserved for synchronous cache) and Turbo (not supported, reserved for synchronous cache). CPU/Bus clock speed is set by the W19, W20 and W21 jumpers.

#### 15.04.4 POWER MANAGEMENT SETUP

This part of the setup sets power conservation options.

Whenever you are not sure about a certain setting, you may refer to the list of default values. The list of defaults is provided in the event that a value has been changed and one wishes to set this option to its original value. Loading the Optimal or Fail-Safe defaults will affect all the options and will reset options previously altered.

The Fail-Safe default settings consist of the safest set of parameters. Use them if the system is behaving erratically. They should always work but do not provide optimal system performance.

The Optimal default values provide optimum performance settings for all devices and system features.

The scroll list displays these options:

<b>OPTIONS</b>	<b>FAIL-SAFE DEFAULTS</b>	<b>OPTIMAL DEFAULTS</b>
Power Management/APM	See Note 1	See Note 1
Instant On Support	Disabled	Enabled
Hard Disk Time Out (Minute)	Disabled	5
Video Low Power Mode	Disabled	Blank
Sleep Mode Time Out	Disabled	2 secs
Suspend Mode Time Out	Disabled	8 secs
Sleep Mode Devices Off	None	Both
Suspend Mode Devices Off	None	Both
Keyboard and PS/2 Mouse Activity	Ignore	Monitor
IRQ3 Activity	Ignore	Monitor
IRQ4 Activity	Ignore	Monitor
IRQ5 Activity	Ignore	Ignore
IRQ6 Activity	Ignore	Monitor
IRQ7 Activity	Ignore	Ignore
IRQ8 Activity	Ignore	Ignore
IRQ9 Activity	Ignore	Ignore
IRQ10 Activity	Ignore	Ignore
IRQ11 Activity	Ignore	Ignore
IRQ14 Activity	Ignore	Monitor
IRQ15 Activity	Ignore	Monitor
Video Access	Ignore	Monitor
All IO Ports Access	Ignore	Ignore
DMA and Local Bus Master Request	Ignore	Ignore

**Note 1:** By default, the Power Management Mode option is set to Disabled, and all the other options read Disabled, hiding their actual default settings. Only when Power Management Mode is set to Enabled, can you see the default values shown above.



The various options in the POWER MANAGEMENT SETUP are described below.

#### POWER MANAGEMENT/APM

This option enables the power management and APM (Advanced Power Management) features. Once this option is enabled, all the other options below can be changed.

#### INSTANT ON SUPPORT

When this option is enabled, the system can go to full power on mode when leaving a power-conserving state.

#### HARD DISK TIME OUT (MINUTE)

This option enables a non-activity timeout, after which the hard disk is put into Standby mode. Note that once the hard disk has entered Standby mode, the next hard disk access will take a few extra seconds to occur. The settings are Disabled, 1 min., 2 min., 3 min., 4 min., 5 min., 6 min., 7 min., 8 min., 9 min., 10 min., 11 min., 12 min., 13 min., 14 min. and 15 min.

#### VIDEO LOW POWER MODE

This option specifies the power management state applied to the video controller after the specified period of inactivity has expired. The settings are Disabled, Blank, Standby and Off.

#### SLEEP MODE TIME OUT

This option sets the timeout period to enter into Sleep Mode when inactivity is detected. The settings are Disabled, 2 sec., 8 sec., 32 sec., 2 min., 8 min., 16 min., and 32 min.

#### SUSPEND MODE TIME OUT

This option sets the timeout period to enter into Suspend Mode from Sleep Mode. The settings are Disabled, 2 sec., 8 sec., 32 sec., 2 min., 8 min., 16 min., and 32 min.

#### SLEEP MODE DEVICES OFF

This option specifies the devices affected by Sleep Mode. The settings are None, Video, Hard disk and Both.

#### SUSPEND MODE DEVICES OFF

This option specifies the devices affected by Suspend Mode. The settings are None, Video, Hard disk and Both.

#### KEYBOARD AND PS/2 MOUSE ACTIVITY

This option, when set to Monitor, permits AMIBIOS to monitor every keyboard and PS/2 mouse activity as an event.

#### IRQ<NUMBER> ACTIVITY

This option, when set to Monitor, permits AMIBIOS to monitor every activity on the specific IRQ line as an event.

#### VIDEO ACCESS

This option, when set to Monitor, permits AMIBIOS to monitor every access as an event.

#### ALL IO PORTS ACCESS

This option, when set to Monitor, permits AMIBIOS to monitor every IO ports access - between 100h and 3FFh inclusively - as an event.

#### DMA AND LOCAL BUS MASTER REQUEST

This option, when set to Monitor, permits AMIBIOS to monitor every DMA and local bus master request as an event.

#### 15.04.5 PCI/PnP SETUP

This part of the setup sets PCI and the Plug and Play related options.

Whenever you are not sure about a certain setting, you may refer to the list of default values. The list of defaults is provided in the event that a value has been changed and you wish to set this option to its original value. Loading the Optimal or Fail-Safe defaults will affect all the options and will reset options previously altered.

The Fail-Safe default settings consist of the safest set of parameters. Use them if the system is behaving erratically. They should always work but do not provide optimal system performance.

The Optimal default values provide optimum performance settings for all devices and system features.

The scroll list displays these options:

<b>OPTIONS</b>	<b>FAIL-SAFE DEFAULTS</b>	<b>OPTIMAL DEFAULTS</b>
Plug and Play Aware O/S	No	No
PCI Latency Timer (PCI Clocks)	64	128
PCI VGA Palette Snoop	Disabled	Disabled
CPU to PCI Write Buffer	Disabled	Enabled
PCI to PCU Write Buffer	Disabled	Disabled
PCI Dynamic Acceleration Decodin	Disabled	Disabled
PCI Interface Retry Count At	16	64
DEVSEL# Decoding Time	Subtractive	Subtractive
PCI Master Bus Time Out	Disabled	14x32
Dynamic Decoding On Memory	Read & Write	Read & Write
PCI Retry Time Out Action	Take Action	Take Action
Dynamic Decoding Buffer	Disabled	Disabled
PCI Master Wait State Write	0	0
Byte Merge Dapability	Disabled	Enabled
Enhanced Byte Merge	Disabled	Enabled
PCI Dynamic Bursting	Disabled	Enabled
2-Way Dynamic Decoding	Disabled	Enabled
PCI Master Concurrent Mode	Disabled	Disabled
IDE Master Concurrent Mode	Disabled	Disabled
Read Backoff	Disabled	Enabled
Master Cycle Snoop Ahead	Disabled	Disabled
OffBoard PCI IDE Card	Auto	Auto

OffBoard PCI IDE Primary IRQ	Disabled	Disabled
OffBoard PCI IDE Secondary IRQ	Disabled	Disabled
IRQ3	PCI/PnP	PCI/PnP
IRQ4	PCI/PnP	PCI/PnP
IRQ5	PCI/PnP	PCI/PnP
IRQ7	PCI/PnP	PCI/PnP
IRQ9	PCI/PnP	PCI/PnP
IRQ10	PCI/PnP	PCI/PnP
IRQ11	PCI/PnP	PCI/PnP
IRQ14	PCI/PnP	PCI/PnP
IRQ15	PCI/PnP	PCI/PnP
Reserved Memory Size	Disabled	Disabled
Reserved Memory Address	C8000	C8000

The various options in the PCI/PnP SETUP are described below.

#### PLUG AND PLAY AWARE O/S

This option permits AMIBIOS to know if the operating system installed in the computer is Plug and Play-aware. The settings are Yes and No.

#### PCI LATENCY TIMER (PCI CLOCKS)

This option defines the latency of all PCI devices on the PCI bus. The choice of settings is in units equal to PCI clocks. The settings are 32, 64, 96, 128, 160, 192, 224 or 248.

#### PCI VGA PALETTE SNOOP

This option must be enabled if any ISA adapter card installed in the system requires VGA palette snooping.

#### PCI IDE BUSMASTER

Setting this option to Enabled specifies that the IDE controller on the PCI local bus has bus mastering capability.

#### OFFBOARD PCI IDE CARD

When this option is set to Auto, AMIBIOS automatically determines the correct setting of the offboard PCI IDE controller card used in the computer. A specific PCI expansion slot can also be set manually by choosing the slot where the offboard PCI IDE controller card is installed. The settings are Auto, Slot 1, Slot 2, Slot 3, Slot 4, Slot 5 and Slot 6.

#### OFFBOARD PCI IDE PRIMARY IRQ

This option specifies the PCI interrupt used by the primary IDE channel on the offboard PCI IDE controller. The settings are Disabled, INTA, INTB, INTC, INTD and Hardwired.

#### OFFBOARD PCI IDE SECONDARY IRQ

This option specifies the PCI interrupt used by the secondary IDE channel on the offboard PCI IDE controller. The settings are Disabled, INTA, INTB, INTC, INTD and Hardwired.

#### IRQ<NUMBER>

This option specifies the bus used by the IRQ and allows the user to specify IRQs for use by legacy ISA adapter cards. To remove IRQs from the pool of available IRQs passed to BIOS configurable devices, set this option to ISA/EISA. The settings are PCI/PnP and ISA/EISA.

#### RESERVED MEMORY SIZE

This option sets the size of the memory area reserved for legacy ISA adapter cards (this area cannot be used by either PnP ISA or PCI adapter cards). The settings are Disabled, 16K, 32K and 64K.

#### RESERVED MEMORY ADDRESS

This option indicates the beginning address (in hex) of the reserved memory area. This memory area (part of ROM memory) is reserved for use by legacy ISA adapter cards. The settings are C0000, C4000, C8000, CC000, D0000, D4000, D8000 and DC000.

#### 15.04.6 PERIPHERAL SETUP

This part of the setup sets I/O controller-related options.

Whenever you are not sure about a certain setting, you may refer to the list of default values. The list of defaults is provided in the event that a value has been changed and one wishes to set this option to its original value. Loading the Optimal or Fail-Safe defaults will affect all the options and will reset options previously altered.

The Fail-Safe default settings consist of the safest set of parameters. Use them if the system is behaving erratically. They should always work but do not provide optimal system performance.

The Optimal default values provide optimum performance settings for all devices and system features.

The scroll list displays these options:

<b>OPTIONS</b>	<b>FAIL-SAFE DEFAULTS</b>	<b>OPTIMAL DEFAULTS</b>
OnBoard FDC	Auto	Auto
OnBoard Serial Port1	Auto	Auto
OnBoard Serial Port2	Auto	Auto
OnBoard Parallel Port	Auto	Auto
Parallel Port Mode	Normal	Normal
Parallel Port DMA Channel	None	None
Parallel Port IRQ Channel	Auto	Auto
OnBoard IDE	Both	Both

The various options in the Peripheral Setup are described below.

#### ONBOARD FDC

This option enables the use of the onboard Floppy Drive Controller. The settings are Disabled, Enabled and Auto.

#### ONBOARD SERIAL PORT1

This option enables Serial Port 1. The possible settings are: Auto, Disabled, 3F8h, 2F8h, 3E8h and 2E8h (if one of these addresses is used by Serial Port 2, it will not be available).

#### ONBOARD SERIAL PORT2

This option enables Serial Port 2. The possible settings are: Auto, Disabled, 3F8h, 2F8h, 3E8h and 2E8h (if one of these addresses is used by Serial Port 1, it will not be available).

#### ONBOARD PARALLEL PORT

This option enables the Parallel Port. The settings are Auto, Disabled, 378h, 278h, and 3BCh.

#### PARALLEL PORT MODE

This option specifies the Parallel Port Mode. The settings are Normal, EPP (Enhanced Parallel Port) and ECP (Extended Capabilities Port).

#### PARALLEL PORT DMA CHANNEL

This option defines which DMA channel will be used for the Parallel Port's ECP mode. The settings are None, 1 and 3.

#### ONBOARD IDE

This option enables the use of the onboard IDE Controller. The settings are Disabled, Both, Primary and Secondary.



## **15.05 UTILITY WINDOW**

### **15.05.1 COLOR SET**

If you select Color Set, it allows you to set up the background/foreground colors of the screen. The settings are: LCD, Army, Pastel, and Sky.

## 15.06 SECURITY WINDOW

When the Supervisor or User icon is selected from the Security window in the main menu, the user can enable the password feature or change the password itself. By default, the user can boot the system and enter the AMIBIOS Setup without any restrictions. Choosing a password for the first time will automatically enable the password feature. At the next bootup, the user will be prompted to enter his password on bootup or when he attempts to enter AMIBIOS Setup, depending on the setting of the PASSWORD CHECKING OPTION in the ADVANCED CMOS SETUP (see the PASSWORD CHECKING OPTION description for the available settings).

☞ **To disable the password, use this option: 1) At the prompt "Enter CURRENT Password", enter your password, 2) Then at the prompt "Enter NEW Password", press ENTER, 3) Then at the prompt "Confirm NEW Password", press ENTER, 4) The screen then displays "Password uninstalled". Make sure you select Save Changes and Exit from the EXIT SETUP window. If you forget your current password, the password feature can be disabled by removing jumper W27 for several minutes; however this will also clear the CMOS Setup, which will then be configured at the BIOS default values.**

### 15.06.1 SUPERVISOR

This option allows you to enable the main password of the supervisor user. You must set a supervisor password before attempting to set user passwords. If you disable this password, all user passwords will automatically be disabled as well.

### 15.06.2 USER

This option allows you to enable and disable a password for each user. A supervisor password must be set before attempting to set user passwords.

### 15.06.3 ANTI-VIRUS

This option allows you to enable and disable anti-virus protection for the hard disk boot sector.

## 15.07 DEFAULT WINDOW

The Default window of the main menu has three options available for automatically reconfiguring the AMIBIOS Setup (the settings are loaded in the program and displayed in their respective fields, but they are not saved in CMOS):

- **Original:** This option allows you to reset all options to the values which were last saved in the CMOS Setup; it is used to restore the values saved in CMOS, after a number of settings have been changed in the AMIBIOS Setup program.
- **Optimal:** This option allows you to load the Optimal Default values. These are common recommended values and should optimize system performance. This feature might be useful in instances where a quick reconfiguration is needed.
- **Fail-Safe:** This option allows you to load the Fail-Safe Default settings. These are worst-case values that are the most stable values that can be chosen. Use this option as a diagnostic aid if the system is behaving erratically.

## 16 VIP-UP SETUP

### 16.01 ACCESSING VIP-UP SETUP PROGRAM

The VIP-UP program is TEKNOR's own Setup program for enabling / disabling / relocating various hardware features on the TEK933.

During boot-up, hit the CTRL and V keys simultaneously, before or when you see the message "Press CTRL-V to enter TEKNOR VIP-UP" at the top of the screen (CTRL-V will work, even if the message display is disabled in VIP-UP).

At the DOS prompt, type "VIP-UP" and press ENTER. This program is available on the utility disk.

There are three screens in the VIP-UP program. The values appearing on the right side of each screen can be modified. Follow the instructions found at the bottom of the screen to select another value.

Use the ↑ and ↓ keyboard keys to move up and down the screen, and on to subsequent or preceding screens. As you do, the value of the selected field is highlighted. If you press the ↓ key when the last field of the screen is highlighted, the next screen is displayed. Pressing the ↑ key when the first field is highlighted will display the first field of the preceding screen; in this way you can move quickly from screen to screen.

Once a field value is highlighted, you can change it by pressing PgDn or typing "+" on the keyboard (in VT100 mode, only "+" will work); this will usually display a higher value. You can also press the PgUp key or type "-" ("-" in VT100 mode), which will usually display a lower value.

Press F10 to save the current configuration and exit (type "U" in VT100 mode). The configuration is not saved until F10 is pressed or "U" is typed. Press ESC to exit without saving the setup.

## 16.02 VIP-UP SCREEN

TEKNOR MICROSYSTEMS INC--- VIPer SETUP	
TEKNOR BIOS Extension Address	C8000H-CBFFFFH
TEKNOR BIOS Window Address	CC000H-CFFFFH
On Board SCSI Controller / BIOS	Enabled
Enter VIP-UP Message	Displayed 3 seconds
VT100 & Serial Download Speed	19200 BPS
VT100 & Serial Download Serial Port	COM1: 3F8H
Use Flash To Store CMOS RAM SETUP	No
Flat Panel VGA Controller Display Mode	CRT Only
ISA Bus Clock Speed	Set by AMI
↑↓ to select options	ESC - Quit without saving
PgDn(+), PgUp(-) to change an option	F10 - (U)pdate Flash BIOS

There are six parts to the screen:

1. Selection of TEKNOR BIOS addresses: The addresses of the TEKNOR BIOS extension and the TEKNOR BIOS window are set in the top part of the screen.
2. On Board SCSI Controller / BIOS: This option allows the user to enable or disable the on board SCSI controller.
3. Enter VIP-UP message: This option allows the user to enable or disable the message "Press CTRL-V to enter TEKNOR VIP-UP" at the top of the screen upon boot-up.
4. VT100 & Serial Download: The VT100 & Serial Download Speed option is for selecting the desired speed for the VT100 and Download modes. The VT100 & Serial Download Serial Port option allows the use of either COM2 or COM1 for the VT100/Serial Download Mode hookup.
5. Use Flash To Store CMOS RAM SETUP: When this option is set to "Yes", the CMOS RAM Setup will be restored from Flash during each power up, as long as the battery is good. If the battery fails, the system returns to the power on default configuration. However, when the battery is replaced, the CMOS RAM Setup is restored from Flash (only the time and date could be lost).

Please note that modifying and saving the CMOS RAM Setup in AMIBIOS Setup does not change the Flash copy; to update Flash, you must return to the VIP-UP Setup and update it while "Use Flash To Store CMOS RAM SETUP" is set to "Yes".

6. Flat Panel VGA Controller Display Mode: Three possible settings exist for the Flat Panel VGA Controller: CRT Only (default), Flat Panel Only or Simultaneous (CRT and Flat Panel are allowed).

## 17 UPDATING BIOS WITH UBIOS

UBIOS is a utility that allows you to take BIOS files from a disk and update the Flash BIOS EPROM with them. It also allows the reverse operation - to copy the contents of the Flash BIOS to files on disk.

The program can be executed in one of two modes:

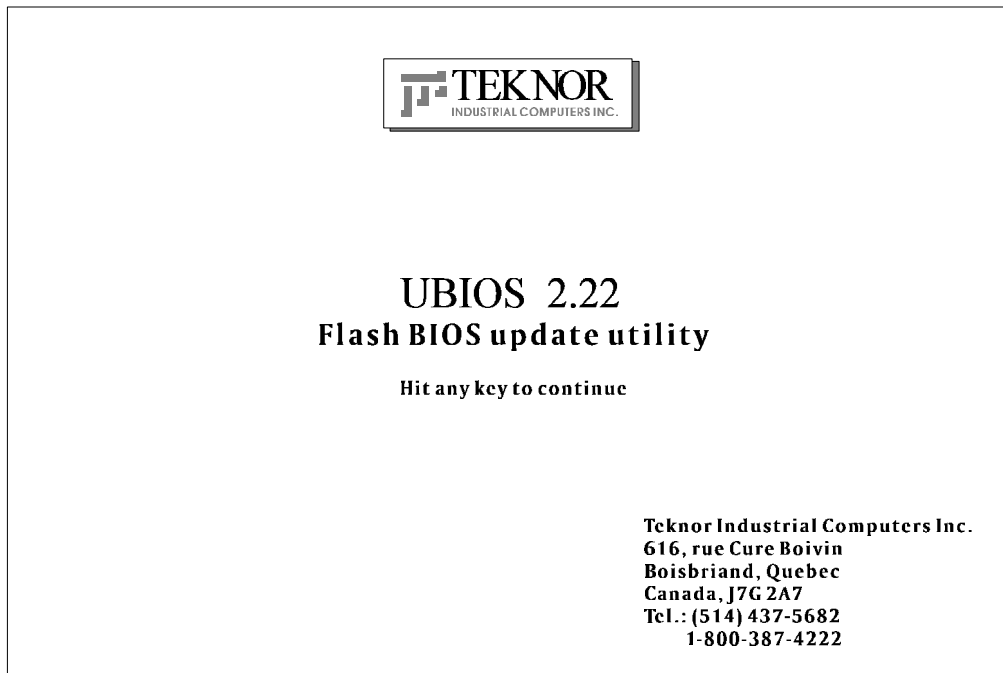
- **Interactive Mode:** In this mode the program is menu-driven. This mode is explained in section 17.01.
- **Batch Mode:** It is also possible to run the program without menus by a command which specifies the selected options and files with parameters. This mode is explained in section 17.02.

Both the Interactive Mode and the Batch Mode are available in VT100 mode (Section 18). The small differences will be explained in the sections noted above.

**Note: Using UBIOS 2.15 and up, will clear the CMOS Setup in ROM. Therefore, it is recommended that you take note of your Setup parameters (especially Hard Disk parameters), so you can reset them afterwards.**

## 17.01 UBIOS - INTERACTIVE MODE

To run the program in interactive mode, type "UBIOS" from the DOS prompt and the following screen will be displayed:



This is simply a presentation screen. To continue, hit any key on the keyboard. This brings you to the main menu.

In VT100 mode, type "UBIOS /VT", leaving a space between "UBIOS" and "/VT".

If you have a monochrome monitor or a CGA monitor, type "UBIOS/low", for low resolution.

The presentation screen in low resolution or VT100 mode is different from the one appearing above, but it works the same way. To continue, you must hit a key on the keyboard, which brings you to the main menu.





- Copy Functions: To copy the contents of the Flash BIOS EPROM to files on disk.

All BIOS can be accessed individually using the appropriate files. Note that the different BIOS files have different extensions:

- All BIOS files can be merged in a single file which has a .BIN extension file.
- SVGA Flat Panel files have the .BFP extension.
- CRT files have the .VGA extension.
- TEKNOR's BIOS extension files have the .EXT extension.
- MAIN BIOS files have the .ROM extension.

## 17.01.2 UPDATE MENU

If you select from the first group of options in the Main Menu (1 to 5), a screen similar to the following appears:

```
-----UPDATE-----
|You are currently using :VGA version AAB
|
|                       :Teknor's extension version 0.60
|
|                       :main BIOS version 0.60
|Directory:F:\LOGICIEL\UBIOS\UBIOS210.NOT
|-----
|
|-----FILES----- |-----DOCUMENTATION-----
|
|                       |No documentation available
|
|      .. <DIR>        ||
|B800_060.BIN          ||
|B800_987.BIN          ||
|B801_612.BIN          ||
|
|                       ||
|                       ||
|                       ||
|                       ||
|                       ||
|                       ||
|                       ||
|                       ||
|                       ||
|                       ||
|                       ||
|                       ||
|-----
```

The screen displays three windows:

- UPDATE: This window displays the current BIOS files being used; it shows all types of BIOS, not just the one selected from the main menu. At the bottom of this window, the current directory is also displayed.

- **FILES:** This window displays the first fourteen files of the type selected in the main menu (All, VGA, TEKNOR or Main) in the current directory.
- **DOCUMENTATION:** If there is no BIOS file for the type you wish to update, this message appears in the DOCUMENTATION window: "No corresponding file in that directory". However, when a filename is displayed in the top window, the DOCUMENTATION window will show the content of a .DOC file, if it is available. This file is a standard text file that can be created with a standard text editor; it must have the same filename as the BIOS file and the extension .DOC. If no .DOC file is available, then this message appears in the DOCUMENTATION window: "No documentation available".

The path and name of the current directory will be displayed next to "Directory:" in the top window.

The FILES window displays the files of the selected type (.BIN, .BFP, .EXT or .ROM). Follow these instructions for selecting a file in the FILE window of the UPDATE screen:

- Letter for a drive: By typing the desired drive letter, you can change the current drive.
- ↑↓ to change files/directory: Use the ↑ or ↓ key to browse through the files of the current directory. When a directory is selected (see <ENTER> to select below), then the ↑ or ↓ key is used to scroll up or down the file list. To move quickly to a directory, press the F2 key and type the first letter of the desired directory next to "Scan:" (displayed in the FILES window).
- <ENTER> to select: Press ENTER to select the highlighted directory or file. When "..<Dir>" is displayed, pressing ENTER will bring you one level up to the parent directory. When a BIOS file is displayed, pressing ENTER will bring a pop-up message on the screen : "Do you really want to update: Flash BIOS, filename (Y/N)". If you type "Y", then the file will be used to update the Flash BIOS.

Aside from the ↑ or ↓ key, other keys can be used to navigate through the FILES window of the current directory:

- HOME: This moves to the top of the current directory and displays the first fourteen files.
- END: This moves to the bottom of the current directory and displays the last fourteen files.
- PAGE UP: This moves up by fourteen in the current directory.
- PAGE DOWN: This moves down by fourteen in the current directory.

The above keys are displayed in a Help screen by pressing the F1 key.

After an update was made with a file of version 0.61 and up, the following message appears on the screen: "Do you want to reboot now (Y/N)". If you type "Y", the system reboots and the new configuration comes into effect; otherwise, if you type "N", a message appears to inform you that you will have to reboot if you want the new configuration to become operational. The program then exits to the operating system prompt.



- File name for Flash BIOS file ( ): The file extension of the selected type will appear in the parentheses: .BIN, .BFP, .VGA, .EXT or .ROM.
- Type in the name of the BIOS file to create and press ENTER to proceed.

Once you complete this step, the program will exit to the operating system prompt.

## 17.02 UBIOS - BATCH MODE

While files can be manually selected using the Interactive Mode, Flash BIOS Update or Copy can be achieved through Batch Mode.

### 17.02.1 BATCH MODE COMMAND LINE PARAMETERS

The command line format is as follows:

UBIOS -B [operation] [filetype] [filename] [options]

where:

[operation] is the Flash BIOS operation you wish to perform, and can be replaced with one of two letters: U for Update, or C for Copy.

[filetype] is the filetype of the BIOS file to program (with an update operation) or to create (with a copy operation), and can be replaced with one of the following:

extension, ALL for All BIOS files in a single file with the .BIN extension,  
VGA for VGA BIOS file with the .BFP or .VGA extension,  
extension, TEKNOR for TEKNOR's BIOS extension with the .EXT extension,  
MAIN for Main BIOS with the .ROM extension.

[filename] is the name of the BIOS file to program (with an update operation) or to create (with a copy operation), and can be replaced with the filename which corresponds to the filetype. For example, if "VGA" was listed as filetype, then the filename could be "FLAT.BFP".

[options] these are optional parameters that may be added:

/C This option will no clear the CMOS Setup when updating main BIOS (AMIBIOS), however this is not recommended since the CMOS Setup should be updated when the main BIOS is changed.

/R Instructs UBIOS to reset the board upon completion of an operation.

/VT This option allows a visual monitoring of the Flash BIOS update/copy operation in VT100 mode.

**Updating BIOS With UBIOS 17-10**



To get a summary of the Batch Mode options from UBIOS, simply call UBIOS with the command line '?'. The command will display a Batch options summary of valid UBIOS command lines. The same help information will also be displayed each time UBIOS detects an error in the command line.

## **18 VT100 MODE**

The TEK933 utilizes a feature known as VT100 Mode. This mode enables your single board computer to run without a local keyboard or screen. That is, operation can be controlled via a remote terminal supporting VT100 Mode or a computer with a terminal emulation program (for example, Telix, Procomm).

### **18.01 VT100 REQUIREMENTS**

To use VT100 Mode, the board must be supplied with  $\pm 12$  volts. This is the voltage required by the RS232 drivers.

The terminal you are using should emulate a VT100 or ANSI terminal. Although this is not an absolute requirement, strange characters may appear on screen if it does not. This occurs because the VT100 recognizes these control characters, and causes them to perform a specific function, for example, screen erase, cursor position, and so on.

## 18.02 VT100 SETUP & CONFIGURATION

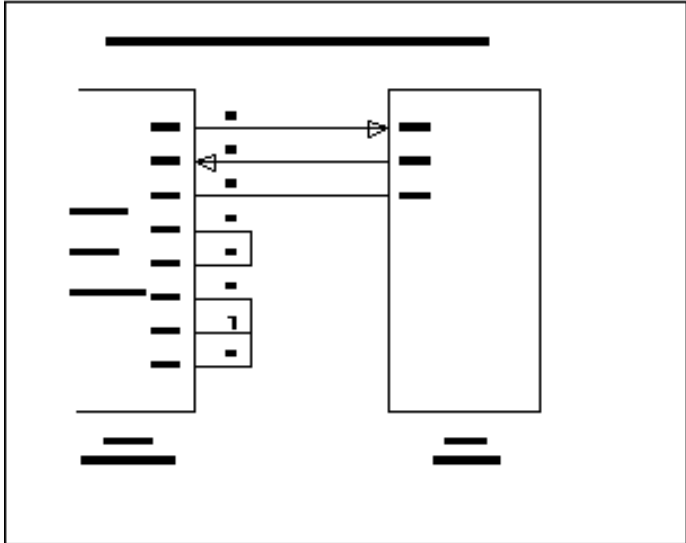
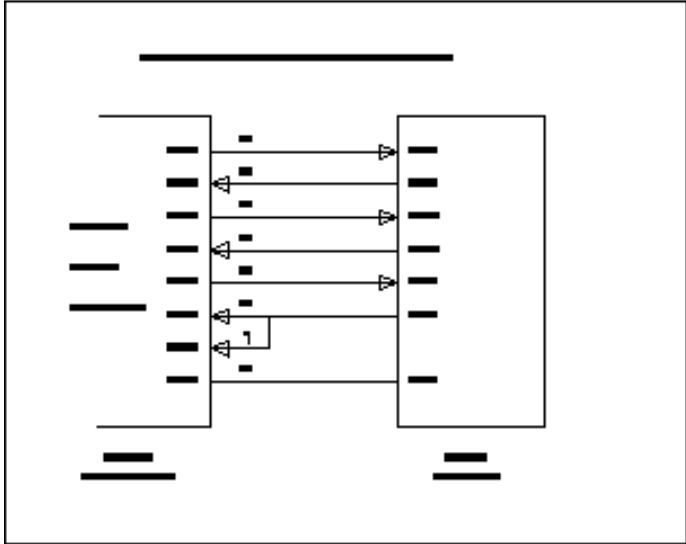
Follow these steps for setting up VT100 Mode:

- Power off your TEK933 and install jumper W8 (3-4) to enable VT100 Mode. Note: VT100 Mode runs on UART1 and UART2.
- Connect the communications cable as shown in Diagram 18-1. Note: If you do not require a full cable for your terminal, you can set up a partial cable by using only the TXD and RXD lines. The control lines can be ignored by looping them back as shown in Diagram 18-2.
- Power on your TEK933 and run VIP-UP Setup by hitting the CTRL and V keys simultaneously, before or when you see the message "Press CTRL-V to enter TEKNOR VIP-UP" at the top of the screen. On the VIP-UP screen, set the "VT100 & Serial Download Speed" at 19200 BPS or 9600 BPS.
- You must respect this protocol:
  - 8 Bits
  - No Parity
  - Echo Off.

If you are running a terminal emulation program, these parameters must be set in it.

**DIAGRAM 18-1: VT100 Full Setup**

**DIAGRAM 18-2: VT100 Partial Setup**



### **18.03 RUNNING WITHOUT A TERMINAL**

The TEK933 can boot up without a screen or terminal attached. However, if VT100 Mode is desired, but the terminal is to be disconnected, you must ensure the control lines are in an active state. Failing this, the system may "hang" while waiting for the control lines to become active. Wiring the system according to Diagram 18-2 allows the lines to remain active. This does not apply if the VT100 jumper is not set.

Furthermore, you can run without any console at all by simply not enabling VT100 Mode and by not installing a video card.

## **APPENDICES**

A    **TEK933 SPECIFICATIONS**

B    **MEMORY & I/O MAPS**

C    **TEK933 BOARD DIAGRAMS**

D    **RECOMMENDED DEVICES & MATING CONNECTORS**

E    **POST CODES & ERROR CODES**

## A TEK933 SPECIFICATIONS

### A.01 BOARD SPECIFICATIONS

**Operating Temperature:** 0° to 62° C (with airflow).

**Storage Temperature:** -30° to +75° C (-20° to +75° C with 10 Base-2 interface).

**Noncondensing  
Relative Humidity:** 5% to 95%.

**Electrical:** Conforms to the electrical specifications in IEEE P996 Bus Specification (PC/AT), the PCI Local Bus Specification, Revision 2.1, and the PICMG, Revision 2.

**Supply Voltage:** VCC = +5V ±5%  
±12V ±5%.

**Supply Current:**

**TABLE A-1:** Supply Current

SUPPLY CURRENT*	P-75	P-90	P-100	P-120	P-133	P-150
+5V	3.03 A	3.35 A	3.57 A	3.80 A	3.36 A	3.48 A
+5V (Sleep)	2.24 A	2.45 A	2.59 A	2.72 A	2.46 A	2.51 A
+5V (Suspend)	1.35 A	1.46 A	1.51 A	1.60 A	1.49 A	1.53 A
+12V	0.096 A	0.096 A	0.096 A	0.096 A	0.096 A	0.096 A
-12V	0.011 A	0.011 A	0.011 A	0.011 A	0.011 A	0.011 A

\* Measured with 8MB System Memory (DRAM), 256KB System Cache and 1MB Video Memory (DRAM).

**Mechanical:**

- Conforms to the mechanical specifications in IEEE P996 Bus Specification (PC/AT), the PCI Local Bus Specification, Revision 2.1, and the PICMG, Revision 2.0.
- 4.80 in. x 13.33 in. / 121.9 mm x 338.5 mm.

## A.02 MTBF

### MEAN TIME BETWEEN FAILURE (MTBF)

The reliability analysis performed on the TEK933 reflects all available options and has resulted in the following predicted reliability:

**TABLE A-2a: Reliability Prediction (Options 1-5)**

Standard Configuration	CPU	MTBF (Hours)	Failure Rate (x10 <sup>-6</sup> )
Option 1: Basic board	Pentium 75MHz	40127	24.9206
	Pentium 90MHz	39843	25.0983
	Pentium 100MHz	39559	25.2786
	Pentium 120MHz	38785	25.7829
	Pentium 133MHz	39211	25.5030
	Pentium 150MHz	38267	26.1325
Option 2: Basic board plus 1MB Video memory	Pentium 75MHz	38818	25.7613
	Pentium 90MHz	38552	25.9389
	Pentium 100MHz	38286	26.1193
	Pentium 120MHz	37561	26.6236
	Pentium 133MHz	37960	26.3437
	Pentium 150MHz	37074	26.9732
Option 3: Basic board plus 2MB Video memory	Pentium 75MHz	37591	26.6019
	Pentium 90MHz	37342	26.7796
	Pentium 100MHz	37092	26.9600
	Pentium 120MHz	36411	27.4642
	Pentium 133MHz	36786	27.1844
	Pentium 150MHz	35953	27.8139
Option 4: Basic board plus 256KB Cache memory and 1MB Video memory	Pentium 75MHz	33291	30.0383
	Pentium 90MHz	33095	30.2159
	Pentium 100MHz	32899	30.3963
	Pentium 120MHz	32362	30.9006
	Pentium 133MHz	32658	30.6207
	Pentium 150MHz	32000	31.2502
Option 5: Basic board plus 256KB Cache memory and 2MB Video memory	Pentium 75MHz	32385	30.8789
	Pentium 90MHz	32199	31.0566
	Pentium 100MHz	32013	31.2370
	Pentium 120MHz	31505	31.7412
	Pentium 133MHz	31785	31.4613
	Pentium 150MHz	31162	32.0909



**TABLE A-2b: Reliability Prediction (Options 6-10)**

<b>Standard Configuration</b>	<b>CPU</b>	<b>MTBF (Hours)</b>	<b>Failure Rate (x10<sup>-6</sup>)</b>
Option 6: Basic board plus 1MB Cache memory and 1MB Video memory	Pentium 75MHz	31002	32.2558
	Pentium 90MHz	30832	32.4334
	Pentium 100MHz	30662	32.6138
	Pentium 120MHz	30195	33.1181
	Pentium 133MHz	30452	32.8382
	Pentium 150MHz	29880	33.4677
Option 7: Basic board plus 1MB Cache memory and 2MB Video memory	Pentium 75MHz	30215	33.0964
	Pentium 90MHz	30053	33.2741
	Pentium 100MHz	29891	33.4545
	Pentium 120MHz	29448	33.9587
	Pentium 133MHz	29692	33.6789
	Pentium 150MHz	29147	34.3084
Option 8: Basic board with Ethernet 10 Base-2 plus 256KB Cache memory and 1MB Video memory	Pentium 75MHz	31764	31.4823
	Pentium 90MHz	31586	31.6600
	Pentium 100MHz	31407	31.8404
	Pentium 120MHz	30917	32.3446
	Pentium 133MHz	31187	32.0647
	Pentium 150MHz	30586	32.6942
Option 9: Basic board with Ethernet 10 Base-2 plus 256KB Cache memory and 2MB Video memory	Pentium 75MHz	30938	32.3230
	Pentium 90MHz	30769	32.5007
	Pentium 100MHz	30599	32.6810
	Pentium 120MHz	30134	33.1853
	Pentium 133MHz	30390	32.9054
	Pentium 150MHz	29820	33.5349
Option 10: Basic board with Ethernet 10 Base-2 plus 1MB Cache memory and 1MB Video memory	Pentium 75MHz	29674	33.6998
	Pentium 90MHz	29518	33.8775
	Pentium 100MHz	29362	34.0579
	Pentium 120MHz	28933	34.5621
	Pentium 133MHz	29170	34.2822
	Pentium 150MHz	28644	34.9117

**TABLE A-2c: Reliability Prediction (Options 11-15)**

<b>Standard Configuration</b>	<b>CPU</b>	<b>MTBF (Hours)</b>	<b>Failure Rate (x10<sup>-6</sup>)</b>
Option 11: Basic board with Ethernet 10 Base-2 plus 1MB Cache memory and 2MB Video memory	Pentium 75MHz	28952	34.5405
	Pentium 90MHz	28803	34.7182
	Pentium 100MHz	28654	34.8985
	Pentium 120MHz	28246	35.4028
	Pentium 133MHz	28471	35.1229
	Pentium 150MHz	27970	35.7524
Option 12: Basic board with Ethernet 10 Base-T plus 256KB Cache memory and 1MB Video memory	Pentium 75MHz	31850	31.3967
	Pentium 90MHz	31671	31.5744
	Pentium 100MHz	31491	31.7548
	Pentium 120MHz	30999	32.2590
	Pentium 133MHz	31270	31.9791
	Pentium 150MHz	30667	32.6087
Option 13: Basic board with Ethernet 10 Base-T plus 256KB Cache memory and 2MB Video memory	Pentium 75MHz	31020	32.2374
	Pentium 90MHz	30850	32.4151
	Pentium 100MHz	30679	32.5955
	Pentium 120MHz	30212	33.0997
	Pentium 133MHz	30469	32.8198
	Pentium 150MHz	29896	33.4493
Option 14: Basic board with Ethernet 10 Base-T plus 1MB Cache memory and 1MB Video memory	Pentium 75MHz	29749	33.6142
	Pentium 90MHz	29593	33.7919
	Pentium 100MHz	29436	33.9723
	Pentium 120MHz	29005	34.4765
	Pentium 133MHz	29243	34.1967
	Pentium 150MHz	28714	34.8262
Option 15: Basic board with Ethernet 10 Base-T plus 1MB Cache memory and 2MB Video memory	Pentium 75MHz	29023	34.4549
	Pentium 90MHz	28875	34.6326
	Pentium 100MHz	28725	34.8130
	Pentium 120MHz	28315	35.3172
	Pentium 133MHz	28541	35.0373
	Pentium 150MHz	28037	35.6669

**TABLE A-2d: Reliability Prediction (Options 16-20)**

<b>Standard Configuration</b>	<b>CPU</b>	<b>MTBF (Hours)</b>	<b>Failure Rate (x10<sup>-6</sup>)</b>
Option 16: Basic board with SCSI Interface	Pentium 75MHz	37851	26.4195
	Pentium 90MHz	37598	26.5972
	Pentium 100MHz	37345	26.7776
	Pentium 120MHz	36654	27.2818
	Pentium 133MHz	37034	27.0019
	Pentium 150MHz	36191	27.6314
Option 17: Basic board with SCSI Interface plus 1MB Video memory	Pentium 75MHz	36684	27.2602
	Pentium 90MHz	36446	27.4379
	Pentium 100MHz	36208	27.6182
	Pentium 120MHz	35559	28.1225
	Pentium 133MHz	35916	27.8426
	Pentium 150MHz	35122	28.4721
Option 18: Basic board with SCSI Interface plus 2MB Video memory	Pentium 75MHz	35586	28.1009
	Pentium 90MHz	35363	28.2785
	Pentium 100MHz	35138	28.4589
	Pentium 120MHz	34527	28.9632
	Pentium 133MHz	34864	28.6833
	Pentium 150MHz	34115	29.3128
Option 19: Basic board with SCSI Interface plus 256KB Cache memory and 1MB Video memory	Pentium 75MHz	31709	31.5372
	Pentium 90MHz	31531	31.7149
	Pentium 100MHz	31353	31.8952
	Pentium 120MHz	30865	32.3995
	Pentium 133MHz	31134	32.1196
	Pentium 150MHz	30535	32.7491
Option 20: Basic board with SCSI Interface plus 256KB Cache memory and 2MB Video memory	Pentium 75MHz	30885	32.3779
	Pentium 90MHz	30717	32.5555
	Pentium 100MHz	30547	32.7359
	Pentium 120MHz	30084	33.2401
	Pentium 133MHz	30340	32.9603
	Pentium 150MHz	29771	33.5898

**TABLE A-2e: Reliability Prediction (Options 21-25)**

<b>Standard Configuration</b>	<b>CPU</b>	<b>MTBF (Hours)</b>	<b>Failure Rate (x10<sup>-6</sup>)</b>
Option 21: Basic board with SCSI Interface plus 1MB Cache memory and 1MB Video memory	Pentium 75MHz	29626	33.7547
	Pentium 90MHz	29470	33.9324
	Pentium 100MHz	29315	34.1127
	Pentium 120MHz	28888	34.6170
	Pentium 133MHz	29123	34.3371
	Pentium 150MHz	28599	34.9666
Option 22: Basic board with SCSI Interface plus 1MB Cache memory and 2MB Video memory	Pentium 75MHz	28906	34.5954
	Pentium 90MHz	28758	34.7730
	Pentium 100MHz	28610	34.9534
	Pentium 120MHz	28203	35.4577
	Pentium 133MHz	28427	35.1778
	Pentium 150MHz	27927	35.8073
Option 23: Basic board with SCSI and Ethernet 10 Base-2 plus 256KB Cache memory and 1MB Video memory	Pentium 75MHz	30320	32.9812
	Pentium 90MHz	30158	33.1589
	Pentium 100MHz	29995	33.3393
	Pentium 120MHz	29548	33.8435
	Pentium 133MHz	29794	33.5636
	Pentium 150MHz	29246	34.1931
Option 24: Basic board with SCSI and Ethernet 10 Base-2 plus 256KB Cache memory and 2MB Video memory	Pentium 75MHz	29567	33.8219
	Pentium 90MHz	29412	33.9996
	Pentium 100MHz	29257	34.1799
	Pentium 120MHz	28832	34.6842
	Pentium 133MHz	29066	34.4043
	Pentium 150MHz	28544	35.0338
Option 25: Basic board with SCSI and Ethernet 10 Base-2 plus 1MB Cache memory and 1MB Video memory	Pentium 75MHz	28410	35.1987
	Pentium 90MHz	28267	35.3764
	Pentium 100MHz	28124	35.5568
	Pentium 120MHz	27731	36.0610
	Pentium 133MHz	27948	35.7811
	Pentium 150MHz	27464	36.4106

**TABLE A-2f: Reliability Prediction (Options 26-30)**

<b>Standard Configuration</b>	<b>CPU</b>	<b>MTBF (Hours)</b>	<b>Failure Rate (x10<sup>-6</sup>)</b>
Option 26: Basic board with SCSI Interface and Ethernet 10 Base-2 plus 1MB Cache memory and 2MB Video memory	Pentium 75MHz	27747	36.0394
	Pentium 90MHz	27611	36.2171
	Pentium 100MHz	27474	36.3975
	Pentium 120MHz	27099	36.9017
	Pentium 133MHz	27306	36.6218
	Pentium 150MHz	26845	37.2513
Option 27: Basic board with SCSI Interface and Ethernet 10 Base-T plus 256KB Cache memory and 1MB Video memory	Pentium 75MHz	30399	32.8957
	Pentium 90MHz	30236	33.0733
	Pentium 100MHz	30072	33.2537
	Pentium 120MHz	29623	33.7579
	Pentium 133MHz	29870	33.4781
	Pentium 150MHz	29319	34.1076
Option 28: Basic board with SCSI Interface and Ethernet 10 Base-T plus 256KB Cache memory and 2MB Video memory	Pentium 75MHz	29642	33.7363
	Pentium 90MHz	29486	33.9140
	Pentium 100MHz	29330	34.0944
	Pentium 120MHz	28903	34.5986
	Pentium 133MHz	29139	34.3187
	Pentium 150MHz	28614	34.9483
Option 29: Basic board with SCSI Interface and Ethernet 10 Base-T plus 1MB Cache memory and 1MB Video memory	Pentium 75MHz	28479	35.1132
	Pentium 90MHz	28336	35.2908
	Pentium 100MHz	28192	35.4712
	Pentium 120MHz	27797	35.9755
	Pentium 133MHz	28015	35.6956
	Pentium 150MHz	27529	36.3251
Option 30: Basic board with SCSI Interface and Ethernet 10 Base-T plus 1MB Cache memory and 2MB Video memory	Pentium 75MHz	27813	35.9538
	Pentium 90MHz	27677	36.1315
	Pentium 100MHz	27539	36.3119
	Pentium 120MHz	27162	36.8161
	Pentium 133MHz	27370	36.5362
	Pentium 150MHz	26906	37.1658

The MTBF is estimated using the prediction data from MIL-HDBK-217F, Reliability Prediction of Electronic Equipment (Dec. 1991).

The TEK933 board is considered functioning in a Ground Fixed environment as defined in MIL-HDBK-217F. The calculations are performed at 20°C with a temperature rise of 10°C which is due to heat dissipated by active components.

It is assumed that only one failure at a time can occur and that the failure of any component will result in the system becoming inoperative or, as a minimum, resulting in a degraded mode of operation requiring repair action. All components are considered as having an exponential distribution of time to failure, with a constant failure rate. A failure rate is attributed to each component called in the parts list, according to the stress levels it is submitted during normal operation.

The components with the highest calculated failure rate in the TEK933 reliability prediction are: the Pentium™ CPU, 33Ω resistors, the 16 bus drivers (74FCT16245) and the Cache memory (256KB and 1MB).

The ball-bearing heatsink/fan assembly has been excluded from the reliability calculations. However, based on manufacturer field data, the heatsink MTBF is equal to 115,000 hours and the mechanical part (fan) does not require any preventive maintenance.

### **A.03 MEETING INDUSTRY STANDARDS**

TEKNOR Quality Standards insist that our products meet or exceed industry standards set by such respected agencies, organizations and associations as UL and CSA.

As a result, the TEK933 has the following built-in features to help ensure that the conditions required for approval are met:

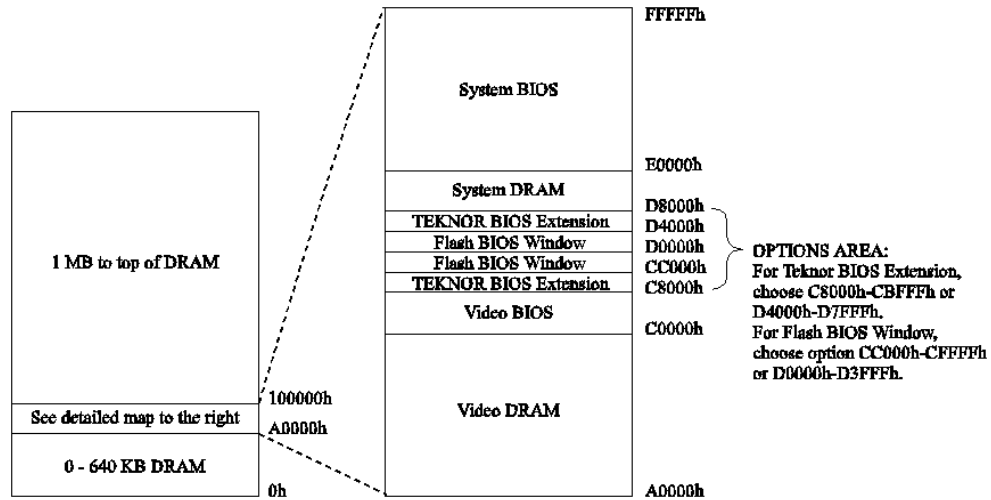
- A current block diode on the battery circuit,
- A current limiter resistor on the battery,
- A protection fuse on the keyboard controller.

TEKNOR computer cards are designed to meet industry standards for customers requiring approval for their equipment.

## B MEMORY & I/O MAPS

In this appendix, the Memory Map Diagram, as well as the Memory Map and I/O Map tables, are included.

**DIAGRAM B-1:** Memory Map Diagram





**TABLE B-1:** Memory Map

<b>ADDRESS</b>	<b>OPTIONAL ADDRESS</b>	<b>FUNCTION</b>
00000-9FFFF		0-640 KB DRAM
A0000-BFFFF		Video DRAM
C0000-C7FFF		Video BIOS
C8000-CBFFF	D4000-D7FFF	TEKNOR BIOS Extension
CC000-CFFFF	D0000-D3FFF	Flash BIOS Window
D8000-DFFFF		System DRAM
E0000-FFFFFF		System BIOS
100000-Top of DRAM		1 MB - Top of DRAM

**TABLE B-2: I/O Map**

ADDRESS	OPTIONAL ADDRESS	OPTIONAL ADDRESS	OPTIONAL ADDRESS	FUNCTION
000-00F				DMA Controller 1
020-03F				Interrupt Controller 1
040-043				Timer
060-064				Keyboard (8742)
070-071				Real-time clock, NMI mask
080-09F				DMA Page Register
0A0-0BF				Interrupt Controller 2
0C0-0DF				DMA Controller 2
A8-AC				Configuration Registers
190-197	290-297	390-397		TEKNOR Control Port
0F0-0FF				Math Coprocessor/ Configuration Registers
1F0-1F7, 3F6				Primary IDE
170-177, 376				Secondary IDE
3F0-3F7	370-377			Floppy Disk
378-37A	3BC-3BE	278-27A		Parallel Port (LPT1 by default)
3F8-3FF (COM1)	2F8-2FF (COM2)	3E8-3EF (COM3)	2E8-2EF (COM4)	UART1 (COM1 by default)
2F8-2FF (COM2)	3F8-3FF (COM1)	3E8-3EF (COM3)	2E8-2EF (COM4)	UART2 (COM2 by default)
3C0-3CF, 3D0-3DF, 3B0-3BB				Graphics Controller

**Note:** The I/O addresses for the On Board SCSI device and the Plug and Play Ethernet device are automatically allocated by the System BIOS.

## **C TEK933 BOARD DIAGRAMS**

Five diagrams are included in this appendix:

**DIAGRAM C-1:** TEK933 Assembly (Top)

**DIAGRAM C-2:** TEK933 Assembly (Bottom)

**DIAGRAM C-3:** TEK933 Configuration

**DIAGRAM C-4:** TEK933 Mechanical Specifications

**DIAGRAM C-5:** TEK933 Block Diagram

DIAGRAM C-1: TEK933 Assembly (Top)

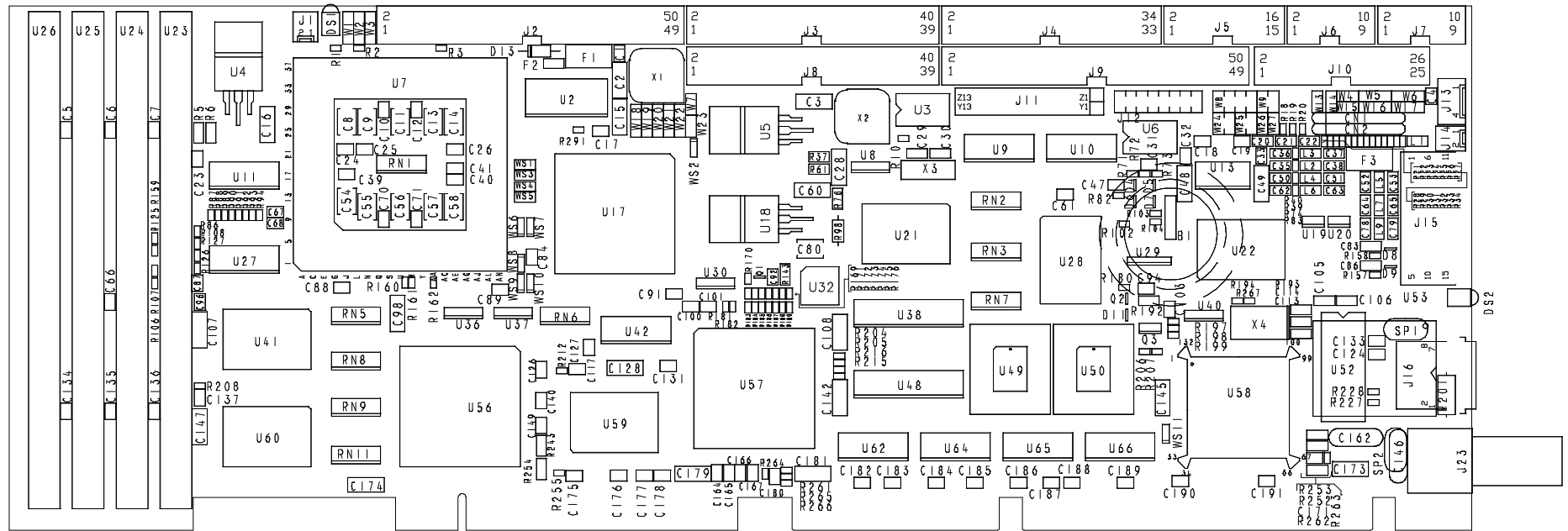
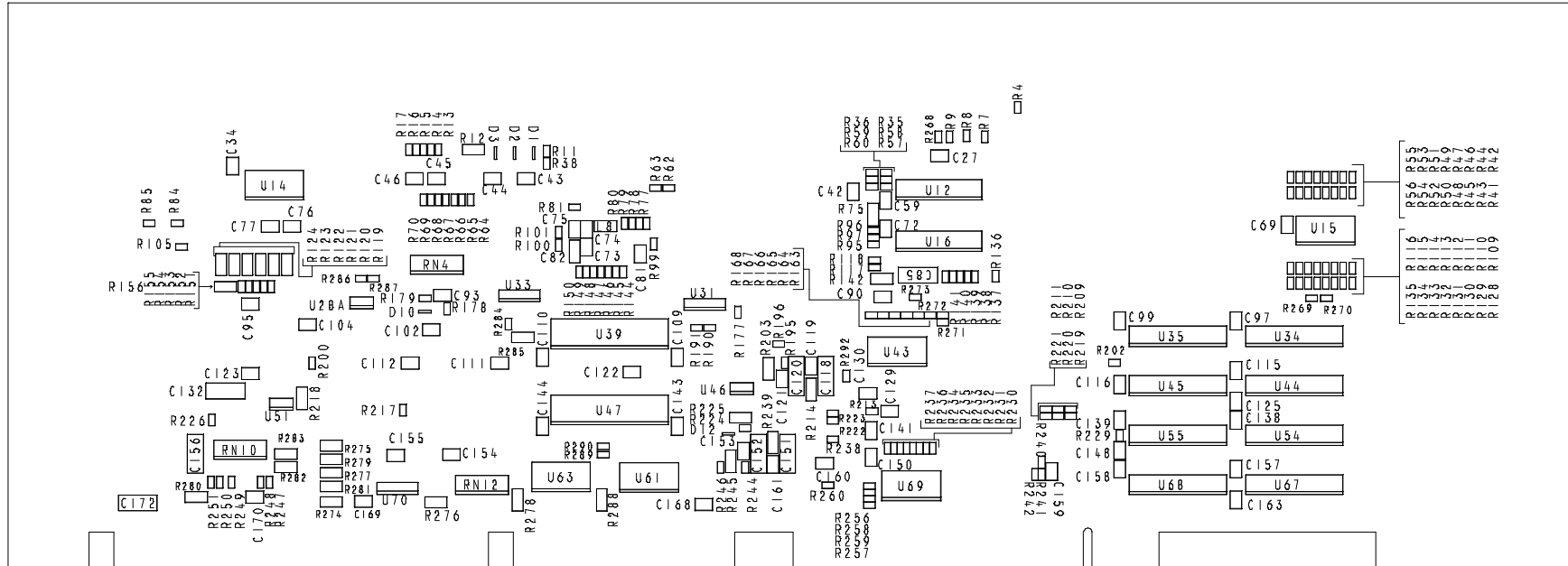
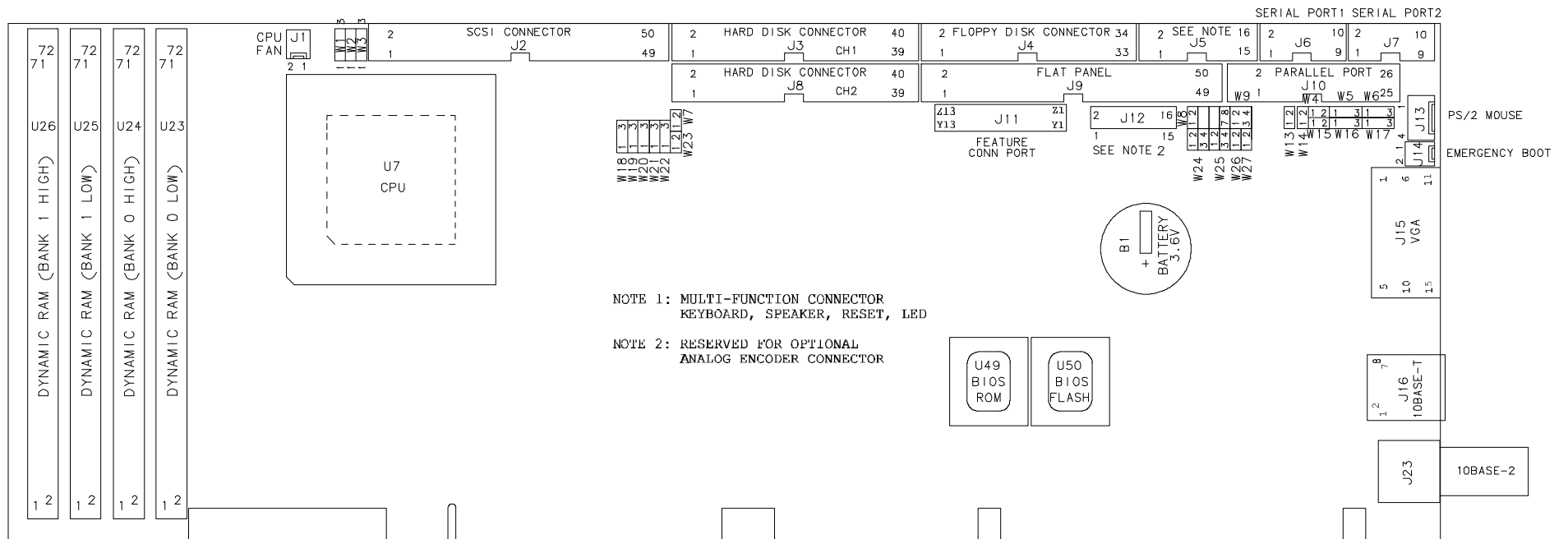


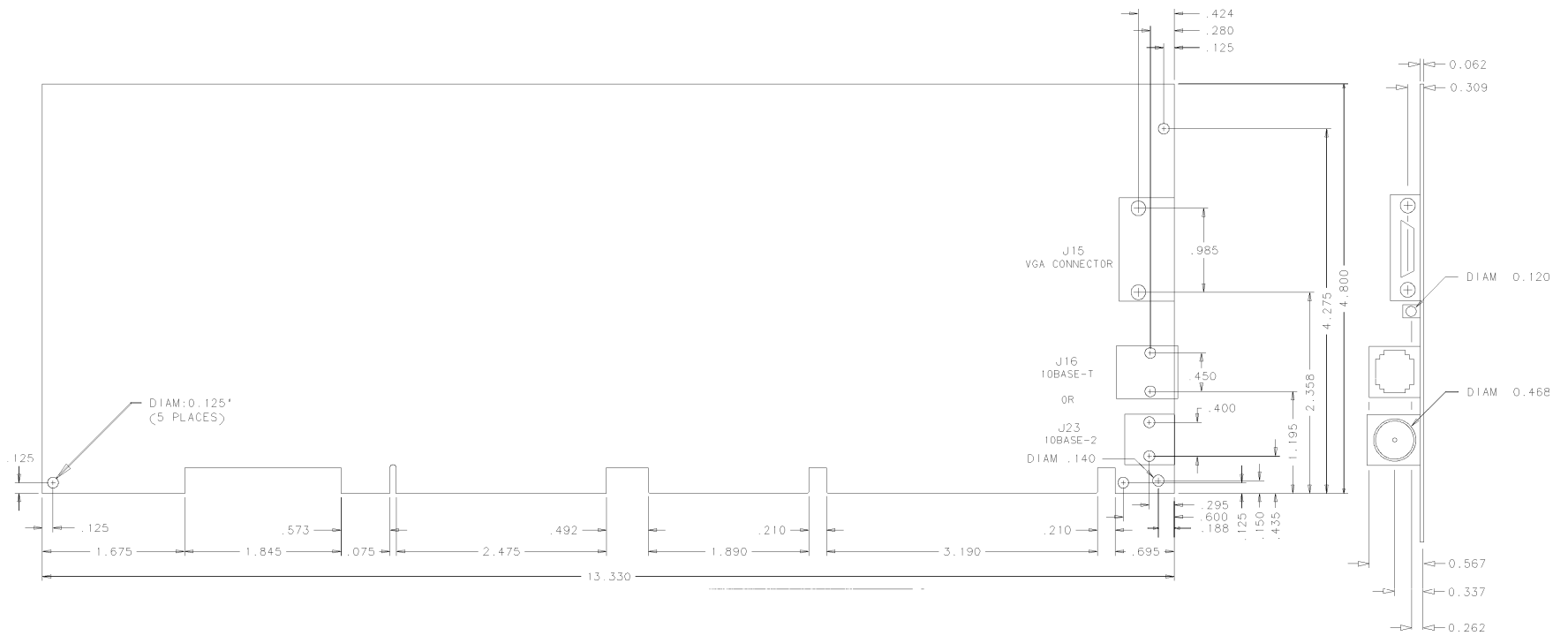
DIAGRAM C-2: TEK933 Assembly (Bottom)



**DIAGRAM C-3: TEK933 Configuration**



**DIAGRAM C-4: TEK933 Mechanical Specifications**



## D RECOMMENDED DEVICES & MATING CONNECTORS

The following is a list of recommended devices and connectors for use on the TEK933. Many other models are available and function equally well. Users are encouraged to check with their local distributors for comparable substitutes.

### DRAM (U23, U24, U25 and U26)

DRAM devices with fast-page mode at 70ns maximum access time are recommended. For example:

MICRON	MT10D25636M-7	(256K*36)
NEC	MC-42255A36B-70	(256K*36)
SAMSUNG	KMM536256C-7	(256K*36)
TOSHIBA	THM362500AS-70	(256K*36)

MICRON	MT18D51236M-7	(512K*36)
--------	---------------	-----------

MICRON	MT9D136M-7	(1M*36)
NEC	MC-421000A36B-70	(1M*36)
SAMSUNG	KMM5361000B-7	(1M*36)
TI	TM124MBK36R-70	(1M*36)
TOSHIBA	THM361020AS-70	(1M*36)

HITACHI	HB56D236B2-7C	(2M*36)
HITACHI	HB56D236BS-7BC	(2M*36)
HITACHI	HB56D236BW-7B	(2M*36)
HITACHI	HB56D236BW-7C	(2M*36)
MICRON	MT18D236M-7	(2M*36)
NEC	MC422000A36B-70	(2M*36)
SAMSUNG	KMM5362000B-7	(2M*36)
TOSHIBA	THM362040AS-60	(2M*36)
TOSHIBA	THM362040AS-70	(2M*36)

MITSUBISHI	MH4M36ANXJ-7	(4M*36)
NEC	MC-424000A36BH-70	(4M*36)
NEC	MC-424000A36BJ-70	(4M*36)
SAMSUNG	KMM5364100-7	(4M*36)

TOSHIBA	THM364020S-70	(4M*36)
---------	---------------	---------



HITACHI	HB56D836BR-70A	(8M*36)
TOSHIBA	THM368020S-70	(8M*36)
TOSHIBA	THM368020SG-70	(8M*36)

## INTERFACE CONNECTORS

The following connectors are recommended for interfacing with the I/O devices. The parts shown here do not have a strain relief but one may be added.

<u>Connector</u>	<u>Recommended Mating Part</u>
Fan Connector (J1)	Leoco 2530 S020013 (housing) Leoco 2533 TCB00A0 (crimp) Molex 22-01-3027 (housing) Molex 08-50-0114 (crimp)
SCSI (J2)	Amp 1-746285-0 [499252-4*] Robinson Nugent IDS-C50PK-TG Thomas & Betts 622-5030 [622-5041*]
Hard Disk (J3 & J8)	Amp 746285-9 [499252-1*] Robinson Nugent IDS-C40PK-TG Thomas & Betts 622-4030 [622-4041*] (40-pin flat cable connector)
Floppy Disk (J4)	Amp 746285-8 [499252-6*] Robinson Nugent IDS-C34PK-TG Thomas & Betts 622-3430 [622-3441*] (34-pin flat cable connector)
Multi-Function (J5)	Amp 746285-3 [499252-8*] Robinson Nugent IDS-C16PK-TG Thomas & Betts 622-1630 [622-1641*] (16-pin flat cable connector)
Serial Port 1 & 2 (J6 & J7)	Amp 746285-1 [499252-5*] Robinson Nugent IDS-C10PK-TG Thomas & Betts 622-1030 [622-1041*] (10-pin flat cable connector)

\* optional strain relief part number shown in square brackets

<u>Connector</u>	<u>Recommended Mating Part</u>
Flat Panel (J9) Assembly)	Teknor 150-105 (High Density Flat Panel Connector Adam Tech HFCS-50SG (Connector only) Hirose HIF6-50D-1.27R (Connector only)
Parallel Port (J10)	Amp 746285-6 [499252-3*] Robinson Nugent IDS-C26PK-TG Thomas & Betts 622-2630 [622-2641*] (Polarized IDC female socket connector connector)
Feature Connector (J11)	Amp 746285-6 [499252-3*] Robinson Nugent IDS-C26PK-TG Thomas & Betts 622-2630 [622-2641*]
PS/2 Connector (J13)	Molex 22-01-3047 (connector) Molex 08-50-0114 (crimp)

\* optional strain relief part number shown in square brackets

## E POST CODES & ERROR CODES

When you power on your system, the Power On Self Test (POST) diagnostic routines check to make sure your system is running properly. A number of check points are covered during these tests. These POST codes are described in E.01.

Fatal errors, which halt the boot process, are communicated through a series of audible beeps. If POST can initialize the system video display, it will display the error message. Beep error codes are described in E.03.

### E.01 POST CODES

POST codes can be displayed by installing a PC diagnostic POST card. This card includes a small display, which indicates the POST code number of specific check-points in the POST routines as they are passed.

#### POST CODE DESCRIPTION

```
*****  
*****  
* Uncompressed INITIALIZATION code check-points  
*  
*****  
*****
```

D0	NMI is Disabled. CPU ID saved. Init code Checksum verification starting.
D1	To do DMA init, Keyboard controller BAT test, start memory refresh and going to 4GB flat mode.
D3	To start Memory sizing.
D4	To comeback to real mode. Execute OEM patch. Set stack.
D5	E000 ROM enabled. Init code is copied to segment 0 and control to be transferred to segment 0.
D6	Control is in segment 0. To check <CTRL><HOME> key and verify main BIOS checksum. If either <CTRL><HOME> is pressed or main BIOS checksum is bad, go to check point E0 else goto check point D7.
D7	Main BIOS runtime code is to be decompressed and control to be passed

to main BIOS in shadow RAM.

**POST DESCRIPTION  
CODE**

\*\*\*\*\*  
\*\*\*\*\*  
\*     Boot block recovery code check points  
\*  
\*\*\*\*\*  
\*\*\*\*\*

- E0     OnBoard Floppy Controller (if any) is initialized.  
       To start base 512K memory test.
- E1     To initialise interrupt vector table.
- E2     To initialise DMA and interrupt controllers.
- E6     To enable floppy and timer IRQ, enable internal Cache.
- ED     Initialize floppy drive.
- EE     Start looking for a diskette in drive A: and read 1st sector of the diskette.
- EF     Floppy read error.
- F0     Start searching 'AMIBOOT.ROM' file in root directory.
- F1     'AMIBOOT.ROM' file not present in root directory.
- F2     Start reading FAT table and analyze FAT to find the clusters occupied by  
       'AMIBOOT.ROM' file.
- F3     Start reading 'AMIBOOT.ROM' file cluster by cluster.
- F4     'AMIBOOT.ROM' file not of proper size.
- F5     Disable internal Cache.
- FB     Detect Flash type present.
- FC     Erase Flash.
- FD     Program Flash.
- FF     Flash program successful. BIOS is going to restart.

\*\*\*\*\*  
\*\*\*\*\*  
\*     Runtime code is uncompressed in F000 shadow RAM  
\*  
\*\*\*\*\*  
\*\*\*\*\*

- 03     NMI is Disabled. To check soft reset/power-on.
- 05     BIOS stack set. Going to disable Cache if any.
- 06     POST code to be uncompressed.
- 07     CPU init and CPU data area init to be done.
- 08     CMOS checksum calculation to be done next.
- 0B     Any initialization before Keyboard BAT to be done next.
- 0C     KB controller I/B free. To issue the BAT command to Keyboard controller.

0E	Any initialization after KB controller BAT to be done next.
0F	Keyboard command byte to be written.
10	Going to issue Pin-23,24 blocking/unblocking command.
<b>POST CODE</b>	<b>DESCRIPTION</b>
11	Going to check pressing of <INS> , <END> key during power-on.
12	To init CMOS if “Init CMOS in every boot” is set or <END> key is pressed. Going to disable DMA and Interrupt controllers.
13	Video display is disabled and port-B is initialized. Chipset init about to begin.
14	8254 timer test about to start.
19	About to start memory refresh test.
1A	Memory Refresh line is toggling. Going to check 15us ON/OFF time.
23	To read 8042 input port and disable Megakey GreenPC feature. Make BIOS code segment writeable.
24	To do any setup before Int vector init.
25	Interrupt vector initialization about to begin. To clear password if necessary.
27	Any initialization before setting video mode to be done.
28	Going for monochrome mode and color mode setting.
2A	Different BUSES init (system, static, output devices) to start if present. <i>(Please see Section E.02 for details of different BUSES).</i>
2B	To give control for any setup required before optional video ROM check.
2C	To look for optional video ROM and give control.
2D	To give control to do any processing after video ROM returns control.
2E	If EGA/VGA not found then do display memory R/W test.
2F	EGA/VGA not found. Display memory R/W test about to begin.
30	Display memory R/W test passed. About to look for the retrace checking.
31	Display memory R/W test or retrace checking failed. To do alternate Display memory R/W test.
32	Alternate Display memory R/W test passed. To look for the alternate display retrace checking.
34	Video display checking over. Display mode to be set next.
37	Display mode set. Going to display the power on message.
38	Different BUSES init (input, IPL, general devices) to start if present. <i>(Please see Section E.02 for details of different BUSES).</i>
39	Display different BUSES initialization error messages. <i>(Please see Section E.02 for details of different BUSES).</i>
3A	New cursor position read and saved. To display the Hit <DEL> message.
40	To prepare the descriptor tables.
42	To enter in virtual mode for memory test.
43	To enable interrupts for diagnostics mode.
44	To initialize data to check memory wrap around at 0:0.

<b>POST CODE</b>	<b>DESCRIPTION</b>
45	Data initialized. Going to check for memory wrap around at 0:0 and finding the total system memory size.
46	Memory wrap around test done. Memory size calculation over. About to go for writing patterns to test memory.
47	Pattern to be tested written in extended memory. Going to write patterns in base 640k memory.
48	Patterns written in base memory. Going to findout amount of memory below 1M memory.
49	Amount of memory below 1M found and verified. Going to findout amount of memory above 1M memory.
4B	Amount of memory above 1M found and verified. Check for soft reset and going to clear memory below 1M for soft reset. (If power on, go to check point# 4Eh).
4C	Memory below 1M cleared. (SOFT RESET) Going to clear memory above 1M.
4D	Memory above 1M cleared. (SOFT RESET) Going to save the memory size. (Goto check point# 52h).
4E	Memory test started.(NOT SOFT RESET) About to display the first 64k memory size.
4F	Memory size display started. This will be updated during memory test. Going for sequential and random memory test.
50	Memory testing/initialization below 1M complete. Going to adjust displayed memory size for relocation/ shadow.
51	Memory size display adjusted due to relocation/ shadow. Memory test above 1M to follow.
52	Memory testing/initialization above 1M complete. Going to save memory size information.
53	Memory size information is saved. CPU registers are saved. Going to enter in real mode.
54	Shutdown successful, CPU in real mode. Going to disable gate A20 line and disable parity/NMI.
57	A20 address line, parity/NMI disable successful. Going to adjust memory size depending on relocation/shadow.
58	Memory size adjusted for relocation/shadow. Going to clear Hit <DEL> message.
59	Hit <DEL> message cleared. <WAIT...> message displayed. About to start DMA and interrupt controller test.
60	DMA page register test passed. To do DMA#1 base register test.

**POST CODE**



62 DMA#1 base register test passed. To do DMA#2 base register test.  
65 DMA#2 base register test passed. To program DMA unit 1 and 2.  
66 DMA unit 1 and 2 programming over.  
To initialize 8259 interrupt controller.  
7F Extended NMI sources enabling is in progress.  
80 Keyboard test started. clearing output buffer, checking for stuck key,  
to issue Keyboard reset command.  
81 Keyboard reset error/stuck key found. To issue Keyboard controller  
interface test command.  
82 Keyboard controller interface test over. To write command byte and init  
circular buffer.  
83 Command byte written, Global data init done. To check for lock-key.  
84 Lock-key checking over. To check for memory size mismatch with  
CMOS.  
85 Memory size check done. To display soft error and check for password or  
bypass setup.  
86 Password checked. About to do programming before setup.  
87 Programming before setup complete. To uncompress SETUP code and  
execute CMOS setup.  
88 Returned from CMOS setup program and screen is cleared.  
About to do programming after setup.  
89 Programming after setup complete.  
Going to display power on screen message.  
8B First screen message displayed. <WAIT...> message displayed.  
PS/2 Mouse check and extended BIOS data area allocation to be done.  
8C Setup options programming after CMOS setup about to start.  
8D Going for hard disk controller reset.  
8F Hard disk controller reset done. Floppy setup to be done next.  
91 Floppy setup complete. Hard disk setup to be done next.  
95 Init of different BUSes optional ROMs from C800 to start.  
(Please see Section E.02 for details of different BUSes).  
96 Going to do any init before C800 optional ROM control.  
97 Any init before C800 optional ROM control is over.  
Optional ROM check and control will be done next.  
98 Optional ROM control is done. About to give control to do  
any required processing after optional ROM returns control and enable  
external  
Cache.

<b>POST CODE</b>	<b>DESCRIPTION</b>
99	Any initialization required after optional ROM test over. Going to setup timer data area and printer base address.
9A	Return after setting timer and printer base address. Going to set the RS-232 base address.
9B	Returned after RS-232 base address. Going to do any initialization before Coprocessor test.
9C	Required initialization before Coprocessor is over. Going to initialize the Coprocessor next.
9D	Coprocessor initialized. Going to do any initialization after Coprocessor test.
9E	Initialization after Coprocessor test is complete. Going to check extended Keyboard, Keyboard ID and num-lock. Keyboard ID command to be issued next.
A2	Going to display any soft errors.
A3	Soft error display complete. Going to set Keyboard typematic rate.
A4	Keyboard typematic rate set. To program memory wait states.
A5	Going to enable parity/NMI.
A7	NMI and parity enabled. Going to do any initialization required before giving control to optional ROM at E000.
A8	Initialization before E000 ROM control over. E000 ROM to get control next.
A9	Returned from E000 ROM control. Going to do any initialization required after E000 optional ROM control.
AA	Initialization after E000 optional ROM control is over. Going to display the system configuration.
AB	To uncompress DMI data and execute DMI POST init.
B0	System configuration is displayed.
B1	Going to copy any code to specific area.
00	Copying of code to specific area done. Going to give control to INT-19 boot loader.

## **E.02 WORD CHECK-POINTS**

Additional WORD check-points are output to port 80h while control is inside the different BUS routines. The LOW BYTE of check-point is the POST code (section E.01) representing the system BIOS check-point from where the control is passed to different BUS routines.

The HIGH BYTE of check-point is the indication of which routine is being executed in different BUSES. The details of HIGH BYTE ('XY') are explained below.

The upper nibble 'X' indicates the function number being executed:

- 0 Disable all devices on the BUS concerned.
- 1 Static devices initialization on the BUS concerned.
- 2 Output device initialization on the BUS concerned.
- 3 Input device initialization on the BUS concerned.
- 4 IPL device initialization on the BUS concerned.
- 5 General device initialization on the BUS concerned.
- 6 Error reporting for the BUS concerned.
- 7 Add-on ROM initialization for all BUSES.

The lower nibble 'Y' indicates the BUS on which the different routines are being executed:

- 0 Generic DIM (Device Initialization Manager).
- 1 On-board System devices.
- 2 ISA devices.
- 3 EISA devices.
- 4 ISA PnP devices.
- 5 PCI devices.

### E.03 BEEP ERROR CODES

All beep codes, except number 8, are fatal errors.

If your system starts beeping during POST, count the number of beeps and check the table below to identify the error. Note that it is not guaranteed that these errors will always generate beeps.

**TABLE E-1:** Beep Error Codes

<b>BEEPS</b>	<b>ERROR MESSAGE</b>	<b>DESCRIPTION</b>
1	Refresh Failure	The memory refresh circuitry is faulty.
2	Parity Error	Parity error in the base memory (the first 64KB block of memory)
3	Base 64KB Memory Failure	Memory failure in the first 64KB.
4	Time Not Operational	A memory failure in the first 64KB of memory, or Timer 1 is not functioning.
5	Processor error	The CPU generated an error.
6	8042 - Gate A20 Failure	Cannot switch to protected mode.
7	Processor Exception Interrupt Error	The CPU on the CPU Card generated an exception interrupt.
8	Display Memory Read/Write Error	The system video adapter is either missing or its memory is faulty. This is not a fatal error.
9	ROM Checksum Error	The ROM checksum value does not match the value encoded in AMIBIOS.
10	CMOS Shutdown Register Read/Write Error	The shutdown register for CMOS RAM has failed.
11	Cache memory bad - do not enable Cache	The Cache memory test failed. Cache memory is disabled. Do not press the CTRL, ALT, SHIFT and + keys (simultaneously) to enable Cache memory.