

MiCS-4514 with recommended supply circuit (top view)

RDRED is a 82 Ω and RDOX is a 133Ω. These resistors are necessary to obtain the right temperatures on the two independant heaters while using a single 5V power supply. The resulting voltages are typically VHRED = 2.4V and VHOX= 1.7V.

MiCS-4514 with measurement circuit (top view)

The two voltages measured on the load resistors are directly linked to the resistances of the RED and OX sensors respectively. RLOAD must be 820 Ω at the lowest in order not to damage the sensitive layer.

Parameter RED sensor/OX sensor	Symbol	Typ	Min	Max	Unit
Heating power	P_H	76/43	71/30	81/50	mW
Heating voltage	V_H	2.4/1.7	-	-	V
Heating current	I_H	32/26	-	-	mA
Heating resistance at nominal power	R_H	74/66	66/59	82/73	Ω

Rating	Symbol	Value / Range	Unit
Maximum heater power dissipation	P_H	88 (RED sensor)/50 (OX sensor)	mW
Maximum sensitive layer power dissipation	P_s	8	mW
Voltage supply/Heating current	V_{supply}	4.9 – 5.1	V
Relative humidity range	RH	5 – 95	%RH
Ambient operating temperature	T_{amb}	-30 – 85	°C
Storage temperature range	T_{sto}	-40 – 120	°C
Storage humidity range	RHsto	5 - 95	%RH

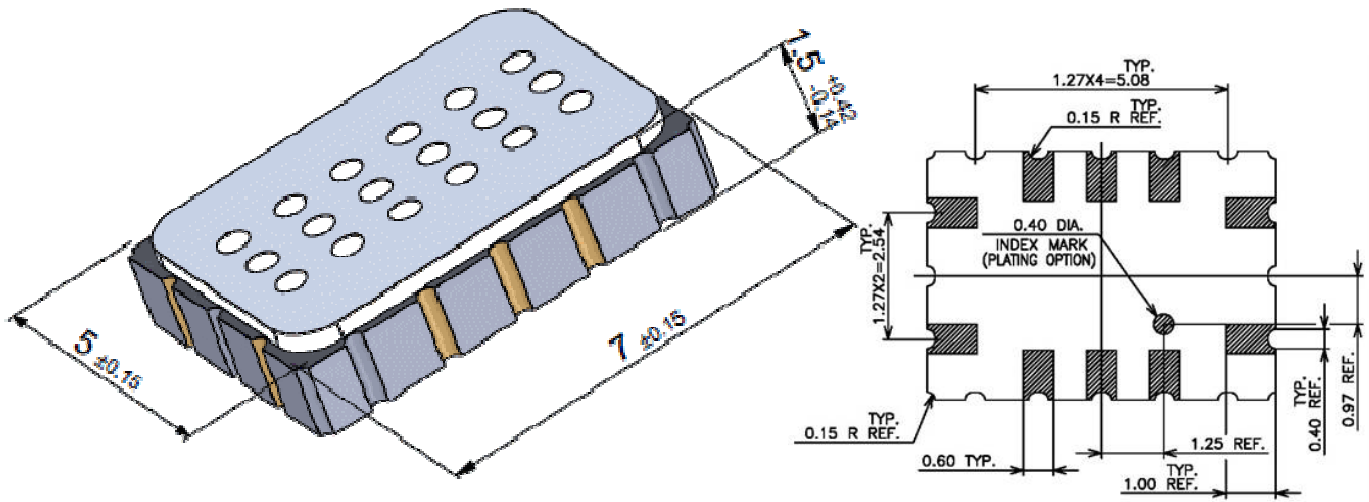

Package outline dimensions

The package is compatible with SMD assembly process.

Pin	Connection
A	Rh1 OX
B	Rs1 OX
C	Rh1 RED
D	Rs1 RED
E	NC
F	Rh2 RED
G	Rs2 RED
H	Rh2 OX
J	Rs2 OX
K	NC

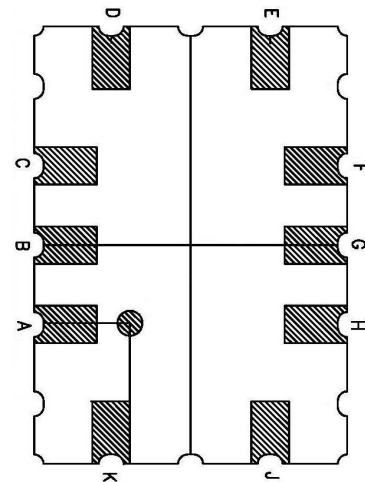

MiCS-4514 configuration (bottom view)

Sensor configuration

The silicon gas sensor structure consists of an accurately micro machined diaphragm with an embedded heating resistor and the sensing layer on top.

The MiCS-4514 includes two sensor chips with independent heaters and sensitive layers. One sensor chip detects oxidising gases (OX) and the other sensor detects reducing gases (RED). The internal connections are shown above.