

Synchronous motors

**6/2 Introduction****6/4 1FT6 motors**

- 6/6 Core type, natural cooling
- 6/8 Standard type, natural cooling
- 6/18 Standard type, forced ventilation
- 6/22 Standard type, water cooling

6/26 1FT7 Compact motors

- 6/28 Core type, natural cooling
- 6/30 Standard type, natural cooling

**6/40 1FK7 Compact/
1FK7 High Dynamic motors**

- 6/42 Compact, natural cooling
- 6/46 High Dynamic, natural cooling
- 6/48 Compact/High Dynamic, natural cooling for Power Modules

6/50 Gearboxes

- 6/50 Series SP+ planetary gearbox for 1FT6 motors
- 6/55 Series SP+ planetary gearbox for 1FK7 motors
- 6/61 Series LP+ planetary gearbox for 1FK7 motors

6/63 Geared motors

- 6/63 1FK7-DYA compact geared motors

6/66 1FN3 linear motors

- 6/76 Standard type, water cooling
- 6/76 Hall-effect sensor box
- 6/76 Connector box
- 6/77 Measuring systems
- 6/77 Liquid cooling

6/78 1FW6 built-in torque motors

- Standard type, water cooling

6/86 1FE1 built-in motors

- 6/97 Standard type, water cooling
- VPM Voltage Protection Module

6/98 2SP1 ECS motor spindles

- Standard type, water cooling

6/104 Selection guides

- Type/mounting position
- Degree of protection

6/105 Dimension drawings

- 6/105 1FT6 motors
- 6/117 1FT7 Compact motors
- 6/119 1FK7 Compact/
1FK7 High Dynamic motors
- 6/122 1FT6 motors with SP+ planetary gearbox
- 6/127 1FK7 motors with SP+ planetary gearbox
- 6/132 1FK7 motors with LP+ planetary gearbox
- 6/135 1FK7-DYA compact geared motors
- 6/136 1FN3 linear motors
- 6/138 1FW6 built-in torque motors
- 6/96 1FE1 built-in motors
- 6/139 2SP1 ECS motor spindles

6/140 CAD CREATOR

- Dimension drawing and 2D/3D CAD generator

Dimension drawings and 2D/3D CAD data are also provided by the CAD CREATOR.

<http://www.siemens.com/cad-creator>



For products approved for Canada and the U.S.A., see Appendix.

Synchronous motors for SINAMICS S120

Introduction

Overview

	1FT6	1FT7 Compact	1FK7 Compact 1FK7 High Dynamic
Cooling	Natural cooling Forced ventilation Water cooling	Natural cooling	Natural cooling
Rated speed	1500 ... 6000 rpm	1500 ... 6000 rpm	2000 ... 6000 rpm
Static torque M_0	0.4 ... 300 Nm (3.54 ... 2655 lb _f -in)	2 ... 70 Nm (17.7 ... 620 lb _f -in)	0.85 ... 48 Nm (7.52 ... 425 lb _f -in) (1FK7 Compact) 1.3 ... 28 Nm (11.5 ... 248 lb _f -in) (1FK7 High Dynamic)
Overload capability up to max.	$4 \times M_0$	$4 \times M_0$	$3 \times M_0$
Encoder system, built-in, for motors with/without DRIVE-CLiQ interface	<ul style="list-style-type: none"> • Incremental encoder • Absolute encoder • Resolver See the technical specifications and the selection and ordering data for the required motor for information about a compatible encoder system.		
Sound pressure level in accordance with EN ISO 1680	55 ... 74 dB (A)	65 ... 74 dB (A)	55 ... 74 dB (A)
Degree of protection EN 60034-5 (IEC 60034-5)	IP64 ... IP68	IP64 ... IP67	IP64 IP65, additional IP67 drive end flange
Insulation of the stator winding EN 60034-1 (IEC 60034-1)	Temperature class 155 (F) for a winding temperature rise of $\Delta T = 100$ K at an ambient temperature of 40 °C (104 °F)		
	With water cooling, inlet temperature max. 30 °C (86 °F)	–	–
Type of motor	Permanent-magnet-excited synchronous motor, 3-phase		
Paint finish	Anthracite RAL 7016	Pearl dark grey RAL 9023	Unpainted, anthracite RAL 7016 (option)
Holding brake	Built-in (option)		
Mounted gearing	<ul style="list-style-type: none"> • Planetary gearbox series SP+ $i = 4$ to 10 (single-stage) $i = 16$ to 50 (2-stage) 	–	<ul style="list-style-type: none"> • Planetary gearbox series LP+ $i = 5$, $i = 10$ (single-stage) • Planetary gearbox series SP+ $i = 4$ to 10 (single-stage) $i = 16$ to 50 (2-stage)

Application

There are many fields of application for the 1FT6/1FT7/1FK7/1FN3/1FW6 synchronous motors.

On machine tools, they are designated and used as feed motors.

On production machines such as printing, packaging and textile machines they are designated as synchronous servo motors.

The motors are referred to generally in this documentation as synchronous motors, due to their principle of operation.

The 1FE1 built-in motors are used as motor spindles in machine tools for turning, milling, or grinding. The 2SP1 ECS motor spindles are a motorized spindle series used in machine tools for milling.

Core types can be supplied for certain motor types. These core types can be express delivered as replacement motors in the event of plant outages and offer the advantage of a quicker spare parts supply. For this reason, core types should be used for configuration wherever possible.

Overview (continued)

	Linear motors	
	1FN3 Peak load	1FN3 Continuous load
Cooling	Water cooling	Water cooling
Velocity at F_{rated}	105 ... 836 m/min (344 ... 2743 ft/min) ¹⁾	129 ... 435 m/min (423 ... 1427 ft/min) ¹⁾
Feedrate force F_{rated}	200 ... 8100 N (45.0 ... 1821 lb _f)	150 ... 10375 N (33.7 ... 2332 lb _f)
Overload capability up to max.	$2.75 \times F_{rated}$	$1.7 \times F_{rated}$
Encoder system (not included in scope of supply)	Linear scale (enclosed or open) <ul style="list-style-type: none"> • Incremental encoder sin/cos 1 V_{pp} • Absolute encoder with EnDat interface 	
Degree of protection EN 60034-5 (IEC 60034-5)	IP65	
Insulation of the stator winding EN 60034-1 (IEC 60034-1)	Temperature class H for a winding temperature of 120 °C (248 °F) Inlet temperature of coolant max. 35 °C (95 °F)	
Type of motor	Permanent-magnet-excited synchronous linear motor, 3-phase	
Paint finish	Unpainted	

	1FW6 built-in torque motors	1FE1 built-in motors	2SP1 ECS motor spindles
Cooling	Water cooling		
Speed at M_{rated}	40 ... 430 rpm	Up to 40000 rpm	Up to 18000 rpm
Static torque M_0	85 ... 3380 Nm (62.7 ... 2493 lb _f -ft)	–	–
Rated torque M_{rated}	109 ... 4590 Nm (80.4 ... 3386 lb _f -ft)	5 ... 820 Nm (3.69 ... 605 lb _f -ft)	42 ... 170 Nm (31.0 ... 125 lb _f -ft)
Overload capability up to max.	$2 \times M_0$	–	–
Encoder system	Rotary encoder <ul style="list-style-type: none"> • Incremental encoder sin/cos 1 V_{pp} • Absolute encoder with EnDat interface 	Hollow-shaft measuring system <ul style="list-style-type: none"> • SIMAG H2 • L&B GEL 244 	Hollow-shaft measuring system Incremental encoder sin/cos 1 V _{pp} 256 S/R (built-in)
Sound pressure level in accordance with EN ISO 1680	–	Depending on spindle design	70 dB (A) ²⁾
Degree of protection EN 60034-5 (IEC 60034-5)	IP23	IP00 or as specified by spindle manufacturer	IP64 (in working area) IP53 (behind the spindle flange)
Insulation of the stator winding EN 60034-1 (IEC 60034-1)	Temperature class 155 (F) for a winding temperature rise of $\Delta T = 100$ K for an ambient temperature of 40 °C (104 °F) Inlet temperature of coolant max. 35 °C (95 °F)	Temperature class 155 (F) with an inlet temperature of coolant of 25 °C (77 °F)	
Type of motor	Permanent-magnet-excited synchronous torque motor, 3-phase	AC main spindle motor in synchronous system with permanent magnets	AC main spindle motor in asynchronous/synchronous system
Paint finish	Unpainted		
Holding brake	–	Using spindle design	–

1) Observe maximum speed of measuring system.

2) Sound pressure level of stock removal and tool changing are not taken into account.

Synchronous motors

Feed motors for SINAMICS S120

1FT6 motors

Overview



1FT6 motors are permanent-magnet excited synchronous motors with compact dimensions.

1FT6 motors with built-in encoders are suitable for use with the SINAMICS S120 drive system.

The fully digital control system of the SINAMICS S120 drive system and the encoder technology of the 1FT6 motors fulfill the highest demands in terms of dynamic performance, speed setting range, and shaft and flange accuracy.

1FT6 motors are available with natural cooling, forced ventilation, or water cooling. With the natural cooling method, heat is dissipated through the surface of the motor, whereas with the forced ventilation method, heat is forced out by means of built-on fans. Maximum power ratings, as well as a high degree of protection, can be achieved using water cooling.

Benefits

- Optimum surface quality of the workpiece thanks to high rotational accuracy (sinusoidal current injection)
- Short non-productive times thanks to high dynamic performance
- Power and signal connections for use in severely contaminated areas
- Easy installation thanks to reduced cabling overhead
- Can absorb high cantilever forces
- High thermal reserves for continuous and overload conditions
- High momentary overload capability (250 ms)
- Extremely high efficiency
- Extremely good dynamic response of the drive due to the lower rotor moments of inertia
- Low torque ripple (average value 1%)
- High degree of protection

Application

- High-performance machine tools
- Machines with stringent requirements in terms of dynamic response, precision and flexibility, e.g. packaging machines, high-bay racking vehicles, conveyor systems, handling equipment, and printing machines

Synchronous motors

Feed motors for SINAMICS S120

1FT6 motors

Technical specifications

Product name	1FT6 motor
Type of motor	Permanent-magnet-excited synchronous motor
Magnet material	Rare-earth magnet material
Cooling	Natural cooling, forced ventilation, water cooling For water cooling max. inlet temperature 30 °C (86 °F) Avoid condensation
Temperature monitoring	KTY 84 temperature sensor in the stator winding
Insulation of the stator winding in accordance with EN 60034-1 (IEC 60034-1)	Temperature class 155 (F) for a winding temperature of $\Delta T = 100$ K at an ambient temperature of 40 °C (104 °F)
Type in accordance with EN 60034-7 (IEC 60034-7)	IM B5 (IM V1, IM V3) IM B14 (IM V18, IM V19) IM B35 with 1FT613
Degree of protection in accordance with EN 60034-5 (IEC 60034-5)	IP64 standard type, IP65 core type
Shaft extension on the drive end in accordance with DIN 748-3 (IEC 60072-1)	Plain shaft
Shaft and flange accuracy¹⁾ in accordance with DIN 42955 (IEC 60072-1)	Tolerance N
Vibration magnitude in accordance with EN 60034-14 (IEC 60034-14)	Grade A is observed up to rated speed
Sound pressure level in accordance with EN ISO 1680, max.	
<ul style="list-style-type: none"> • Motors with natural/water cooling <ul style="list-style-type: none"> - 1FT602 ... 1FT604 55 dB (A) - 1FT606 ... 1FT613 70 dB (A) • Motors with forced ventilation <ul style="list-style-type: none"> - 1FT608/1FT610 70 dB (A) - 1FT613 74 dB (A) 	

Product name	1FT6 motor
Encoder systems, built-in, for motors without DRIVE-CLiQ interface	<ul style="list-style-type: none"> • Incremental encoder sin/cos 1 V_{pp} 2048 S/R • Absolute encoder multi-turn (traversing range 4096 revolutions) with EnDat interface 1FT603 ... 1FT613: 2048 S/R 1FT602: 512 S/R • Multi-pole resolver (number of poles corresponds to number of pole pairs of the motor) • 2-pole resolver
Encoder systems, built-in, for motors with DRIVE-CLiQ interface	<ul style="list-style-type: none"> • 22 bit incremental encoder (2048 S/R internal) • Absolute encoder single-turn + 12 bit multi-turn (traversing range 4096 revolutions) 1FT603 ... 1FT613: 22 bit single-turn (2048 S/R internal) 1FT602: 20 bit single-turn (512 S/R internal) • 15 bit resolver • 14 bit resolver
Connection	Connectors for signals and power Terminal box possible on 1FT61
Paint finish	Anthracite RAL 7016
2nd rating plate	Enclosed separately
Options	<ul style="list-style-type: none"> • Shaft extension on the drive end with fitted key and keyway (half-key balancing) • Vibration magnitude Grade R • Built-in holding brake • Degree of protection IP67, IP68 M5 sealing air connection present (except with forced ventilation) • Terminal box for power terminal • Planetary gearbox, built-on (requirement: Plain shaft extension, shaft and flange accuracy tolerance N, vibration magnitude grade A, and IP65 degree of protection)

S/R = signals/revolution

¹⁾ Shaft extension run-out, concentricity of spigot and shaft and perpendicularity of mounting face of flange to shaft.

Synchronous motors

Feed motors for SINAMICS S120

1FT6 core type motors Natural cooling

Selection and Ordering Data

Rated speed	Shaft height	Rated power	Static torque	Rated torque ¹⁾	Rated current	1FT6 synchronous motors Natural cooling	Number of pole pairs	Rotor moment of inertia (without brake)	Weight (without brake)
n_{rated}	SH	P_{rated} at $\Delta T=100\text{ K}$	M_0 at $\Delta T=100\text{ K}$	M_{rated} at $\Delta T=100\text{ K}$	I_{rated} at $\Delta T=100\text{ K}$	Order No. Core type		J	m
rpm		kW (HP)	Nm (lb _f -in)	Nm (lb _f -in)	A			10^{-4} kgm^2 ($10^{-3}\text{ x lb}_f\text{-in-s}^2$)	kg (lb)
2000	100	4.8 (6.44)	27 (239)	23 (204)	11	1FT6102 - 1AC71 - ■■■■ 1	4	99 (87.6)	27.5 (60.6)
		8.0 (10.7)	50 (443)	38 (336)	17.6	1FT6105 - 1AC71 - ■■■■ 1	4	168 (149)	39.5 (87.1)
3000	48	1.4 (1.88)	5 (44.3)	4.3 (38.1)	2.9	1FT6044 - 1AF71 - ■■■■ 1	2	5.1 (4.51)	8.3 (18.3)
		1.5 (2.01)	6 (53.1)	4.7 (41.6)	3.4	1FT6062 - 1AF71 - ■■■■ 1	3	8.5 (7.52)	9.5 (20.9)
	63	2.2 (2.95)	9.5 (84.1)	7 (62.0)	4.9	1FT6064 - 1AF71 - ■■■■ 1	3	13 (11.5)	12.5 (27.6)
		3.2 (4.29)	13 (115)	10.3 (91.2)	8.7	1FT6082 - 1AF71 - ■■■■ 1	4	30 (26.6)	15 (33.1)
	80	4.6 (6.17)	20 (177)	14.7 (130)	11	1FT6084 - 1AF71 - ■■■■ 1	4	48 (42.5)	20.5 (45.2)
		5.8 (7.78)	27 (239)	18.5 (164)	13	1FT6086 - 1AF71 - ■■■■ 1	4	66.5 (58.9)	25.5 (56.2)
4500	63	1.7 (2.28)	6 (53.1)	3.6 (31.9)	3.9	1FT6062 - 1AH71 - ■■■■ 1	3	8.5 (7.52)	9.5 (20.9)
		2.3 (3.08)	9.5 (84.1)	4.8 (42.5)	5.5	1FT6064 - 1AH71 - ■■■■ 1	3	13 (11.5)	12.5 (27.6)
	80	4.9 (6.57)	20 (177)	10.5 (92.9)	12.5	1FT6084 - 1AH71 - ■■■■ 1	4	48 (42.5)	20.5 (45.2)
		5.7 (7.64)	27 (239)	12 (106)	12.6	1FT6086 - 1AH71 - ■■■■ 1	4	66.5 (58.9)	25.5 (56.2)
6000	36	0.88 (1.18)	2 (17.7)	1.4 (12.4)	2.1	1FT6034 - 1AK71 - ■■■■ 1	2	1.1 (0.97)	4.4 (9.70)
	80	4.1 (5.50)	20 (177)	6.5 (57.5)	9.2	1FT6084 - 1AK71 - ■■■■ 1	4	48 (42.5)	20.5 (45.2)

Type:	IM B5	1
Connector outlet direction:	Transverse right (not for 1FT603/1FT604/1FT606) Transverse left (not for 1FT603/1FT604/1FT606) Axial NDE Axial DE	1 2 3 4
Encoder systems for motors without DRIVE-CLiQ interface:	Incremental encoder sin/cos 1 V _{pp} , 2048 S/R Absolute encoder EnDat 2048 S/R ¹⁾	A E
Encoder systems for motors with DRIVE-CLiQ interface:	Incremental encoder 22 bit Absolute encoder, 22 bit single-turn + 12 bit multi-turn ¹⁾	D F
Shaft extension:	Shaft and flange accuracy:	Holding brake:
Plain shaft	Tolerance N	with
Plain shaft	Tolerance N	without
		G H
Vibration magnitude:	Degree of protection:	1
Grade A	IP65	

Synchronous motors

Feed motors for SINAMICS S120

1FT6 core type motors
Natural cooling

Selection and Ordering Data

Motor type (continued)	Static current I_0 at M_0 $\Delta T=100$ K A	Calculated power $P_{calc}^{4)}$ P_{calc} for M_0 $\Delta T=100$ K kW (HP)	SINAMICS S120 Motor Module		Power cable with complete shield Motor connection (and brake connection) via power connector		
			Rated output current ³⁾ I_{rated} A	Booksize format Order No.	Power connector Size	Motor cable cross-section ²⁾ mm ²	Order No. Pre-assembled cable
1FT6102-1AC7...	12.1	5.7 (7.64)	18	6SL312 - TE21 - 8AA3	1.5	4 x 1.5	6FX 002 - 5 S21 -
1FT6105-1AC7...	21.4	10.5 (14.1)	30	6SL312 - 1 TE23 - 0AA3	1.5	4 x 4	6FX 002 - 5 S41 -
1FT6044-1AF7...	3	1.6 (2.15)	3	6SL312 - TE13 - 0AA3	1	4 x 1.5	6FX 002 - 5 S01 -
1FT6062-1AF7...	4.1	1.9 (2.55)	5	6SL312 - TE15 - 0AA3	1	4 x 1.5	6FX 002 - 5 S01 -
1FT6064-1AF7...	6.1	3.0 (4.02)	9	6SL312 - TE21 - 0AA3	1	4 x 1.5	6FX 002 - 5 S01 -
1FT6082-1AF7...	9.6	4.1 (5.50)	18	6SL312 - TE21 - 8AA3	1.5	4 x 1.5	6FX 002 - 5 S21 -
1FT6084-1AF7...	13.2	6.3 (8.45)	18	6SL312 - TE21 - 8AA3	1.5	4 x 1.5	6FX 002 - 5 S21 -
1FT6086-1AF7...	16.4	8.5 (11.4)	18	6SL312 - TE21 - 8AA3	1.5	4 x 2.5	6FX 002 - 5 S31 -
1FT6062-1AH7...	5.7	2.8 (3.75)	9	6SL312 - TE21 - 0AA3	1	4 x 1.5	6FX 002 - 5 S01 -
1FT6064-1AH7...	9.0	4.5 (6.03)	9	6SL312 - TE21 - 0AA3	1	4 x 1.5	6FX 002 - 5 S01 -
1FT6084-1AH7...	19.8	9.4 (12.6)	18	6SL312 - TE21 - 8AA3	1.5	4 x 4	6FX 002 - 5 S41 -
1FT6086-1AH7...	23.3	12.7 (17.0)	30	6SL312 - 1 TE23 - 0AA3	1.5	4 x 4	6FX 002 - 5 S41 -
1FT6034-1AK7...	2.6	1.3 (1.74)	3	6SL312 - TE13 - 0AA3	1	4 x 1.5	6FX 002 - 5 S01 -
1FT6084-1AK7...	24.1	12.6 (16.9)	30	6SL312 - 1 TE23 - 0AA3	1.5	4 x 4	6FX 002 - 5 S41 -
Cooling:							
Internal air cooling				0			
External air cooling				1			
Motor Module:							
Single Motor Module				1			
Double Motor Module				2			
Type of power cable:							
MOTION-CONNECT 800					8		
MOTION-CONNECT 500					5		
Without brake cores						C	
With brake cores						D	
For length code as well as power and signal cables, see Connection system MOTION-CONNECT.						

6

¹⁾ If the absolute encoder is used, M_{rated} is reduced by 10%.

²⁾ The current carrying capacity of the power cables complies with IEC 60204-1 for installation type C under continuous operating conditions at an ambient air temperature of 40 °C (104 °F), designed for I_0 (100 K), PVC/PUR-insulated cable.

³⁾ With default setting of the pulse frequency.

⁴⁾ $P_{calc} [kW] = \frac{M_0 [Nm] \times n_{rated}}{9550}$ $P_{calc} [HP] = \frac{M_0 [lb_f \cdot in] \times n_{rated}}{63000}$

Synchronous motors

Feed motors for SINAMICS S120

1FT6 standard type motors Natural cooling

Selection and Ordering Data									
Rated speed	Shaft height	Rated power	Static torque	Rated torque ¹⁾	Rated current	1FT6 synchronous motors Natural cooling	Number of pole pairs	Rotor moment of inertia (without brake)	Weight (without brake)
n_{rated}	SH	P_{rated} at $\Delta T=100$ K	M_0 at $\Delta T=100$ K	M_{rated} at $\Delta T=100$ K	I_{rated} at $\Delta T=100$ K	Order No. Standard type		J	m
rpm		kW (HP)	Nm (lb _f -in)	Nm (lb _f -in)	A			10^{-4} kgm ² (10^{-3} x lb _f -in-s ²)	kg (lb)
1500	100	3.8 (5.10)	27 (239)	24.5 (217)	8.4	1FT6102 - 8AB7 ■ - ■ ■ ■ ■	4	99 (87.6)	27.5 (60.6)
		6.4 (8.58)	50 (443)	41 (363)	14.5	1FT6105 - 8AB7 ■ - ■ ■ ■ ■	4	168 (149)	39.5 (87.1)
		9.6 (12.9)	70 (620)	61 (540)	20.5	1FT6108 - 8AB7 ■ - ■ ■ ■ ■	4	260 (230)	55.5 (122)
	132	9.7 (13.0)	75 (664)	62 (549)	19	1FT6132 - 6AB7 1 - ■ ■ ■ ■	3	430 (381)	85 (187)
		11.8 (15.8)	95 (841)	75 (664)	24	1FT6134 - 6AB7 1 - ■ ■ ■ ■	3	547 (484)	100 (221)
		13.8 (18.5)	115 (1018)	88 (779)	27	1FT6136 - 6AB7 1 - ■ ■ ■ ■	3	664 (588)	117 (258)
Type:		IM B5 IM B14 ²⁾ (not for 1FT613)				1			
Connector outlet direction:		Transverse right Transverse left Axial NDE (not for 1FT613) Axial DE				2	1 2 3 4		
Terminal box/ cable entry:		Transverse/from right Transverse/from left Axial/from NDE Axial/from DE					5 6 7 8		
Encoder systems for motors without DRIVE-CLiQ interface:		Incremental encoder sin/cos 1 V _{pp} 2048 S/R Absolute encoder EnDat 2048 S/R ¹⁾ Multi-pole resolver 2-pole resolver						A E S T	
Encoder systems for motors with DRIVE-CLiQ interface:		Incremental encoder 22 bit Absolute encoder, 22 bit single-turn + 12 bit multi-turn ¹⁾ 15 bit resolver 14 bit resolver						D F U P	
Shaft extension:		Shaft and flange accuracy:		Holding brake:					
Fitted key and keyway		Tolerance N		without					A
Fitted key and keyway		Tolerance N		with					B
Fitted key and keyway		Tolerance R		without					D
Fitted key and keyway		Tolerance R		with					E
Plain shaft		Tolerance N		without					G
Plain shaft		Tolerance N		with					H
Plain shaft		Tolerance R		without					K
Plain shaft		Tolerance R		with					L
Vibration magnitude:		Degree of protection:							
Grade A		IP64							0
Grade A		IP65							1
Grade A		IP67							2
Grade A		IP68							6
Grade R		IP64							3
Grade R		IP65							4
Grade R		IP67							5
Grade R		IP68							7

To select the degree of protection and type, see Selection guides.



Synchronous motors

Feed motors for SINAMICS S120

1FT6 standard type motors
Natural cooling

Selection and Ordering Data

Motor type (continued)	Static current I_0 at M_0 $\Delta T=100$ K A	Calculated power P_{calc} ⁵⁾ P_{calc} for M_0 $\Delta T=100$ K kW (HP)	SINAMICS S120 Motor Module		Power cable with complete shield		
			Rated output current ⁴⁾ I_{rated} A	Booksize format Order No.	Motor connection (and brake connection) via power connector		
					Power connector	Motor cable cross-section ³⁾ Size mm ²	Order No. Pre-assembled cable
1FT6102-8AB7...	8.7	4.2 (5.63)	9	6SL312 - TE21 - 0AA3	1.5	4 x 1.5	6FX 002 - 5S21 -
1FT6105-8AB7...	16.0	7.9 (10.6)	18	6SL312 - TE21 - 8AA3	1.5	4 x 2.5	6FX 002 - 5S31 -
1FT6108-8AB7...	22.3	11.0 (14.8)	30	6SL312 - 1TE23 - 0AA3	1.5	4 x 4	6FX 002 - 5S41 -
1FT6132-6AB7...	21.6	11.8 (15.8)	30	6SL312 - 1TE23 - 0AA3	1.5	4 x 4	6FX 002 - 5S41 -
1FT6134-6AB7...	27.0	14.9 (20.0)	30	6SL312 - 1TE23 - 0AA3	1.5	4 x 4	6FX 002 - 5S41 -
1FT6136-6AB7...	34	18.1 (24.3)	45	6SL312 - 1TE24 - 5AA3	1.5	4 x 10	6FX 002 - 5S64 -
Cooling:							
Internal air cooling					0		
External air cooling					1		
Motor Module:							
Single Motor Module					1		
Double Motor Module					2		
Type of power cable:							
MOTION-CONNECT 800						8	
MOTION-CONNECT 500						5	
Without brake cores							C
With brake cores							D
For length code as well as power and signal cables, see Connection system MOTION-CONNECT.						

6

¹⁾ If the absolute encoder is used, M_{rated} is reduced by 10%.

²⁾ Same flange as for IM B5 type, but with metric threaded insert in the four fixing holes.

³⁾ The current carrying capacity of the power cables complies with IEC 60204-1 for installation type C under continuous operating conditions at an ambient air temperature of 40 °C (104 °F), designed for I_0 (100 K), PVC/PUR-insulated cable.

⁴⁾ With default setting of the pulse frequency.

⁵⁾ P_{calc} [kW] = $\frac{M_0$ [Nm] x n_{rated} }{9550} P_{calc} [HP] = $\frac{M_0$ [lb_f-in] x n_{rated} }{63000}

Synchronous motors

Feed motors for SINAMICS S120

1FT6 standard type motors Natural cooling

Selection and Ordering Data

Rated speed	Shaft height	Rated power	Static torque	Rated torque ¹⁾	Rated current	1FT6 synchronous motors Natural cooling	Number of pole pairs	Rotor moment of inertia (without brake)	Weight (without brake)
n_{rated}	SH	P_{rated} at $\Delta T=100\text{ K}$	M_0 at $\Delta T=100\text{ K}$	M_{rated} at $\Delta T=100\text{ K}$	I_{rated} at $\Delta T=100\text{ K}$	Order No. Standard type		J	m
rpm		kW (HP)	Nm (lb _f -in)	Nm (lb _f -in)	A			10 ⁻⁴ kgm ² (10 ⁻³ x lb _f -in-s ²)	kg (lb)
2000	63	0.8 (1.07)	4 (35.4)	3.7 (32.7)	1.9	1FT6061 - 6AC7	3	6 (5.31)	8 (17.6)
		1.1 (1.48)	6 (53.1)	5.2 (46.0)	2.6	1FT6062 - 6AC7	3	8.5 (7.52)	9.5 (20.9)
		1.7 (2.28)	9.5 (84.1)	8 (70.8)	3.8	1FT6064 - 6AC7	3	13 (11.5)	12.5 (27.6)
	80	1.6 (2.15)	8 (70.8)	7.5 (66.4)	4.1	1FT6081 - 8AC7	4	21 (18.6)	12.5 (27.6)
		2.4 (3.22)	13 (115)	11.4 (101)	6.6	1FT6082 - 8AC7	4	30 (26.6)	15 (33.1)
		3.5 (4.69)	20 (177)	16.9 (150)	8.3	1FT6084 - 8AC7	4	48 (42.5)	20.5 (45.2)
		4.7 (6.30)	27 (239)	22.5 (199)	10.9	1FT6086 - 8AC7	4	66.5 (58.9)	25.5 (56.2)
	100	4.8 (6.44)	27 (239)	23 (204)	11	1FT6102 - 8AC7	4	99 (87.6)	27.5 (60.6)
		8.0 (10.7)	50 (443)	38 (336)	17.6	1FT6105 - 8AC7	4	168 (149)	39.5 (87.1)
		11.5 (15.4)	70 (620)	55 (487)	24.5	1FT6108 - 8AC7	4	260 (230)	55.5 (122)
	132	11.5 (15.4)	75 (664)	55 (487)	23	1FT6132 - 6AC7 1	3	430 (381)	85 (187)
		13.6 (18.2)	95 (841)	65 (575)	27	1FT6134 - 6AC7 1	3	547 (484)	100 (221)
15.5 (20.8)		115 (1018)	74 (655)	30	1FT6136 - 6AC7 1	3	664 (588)	117 (258)	

Type:	IM B5 IM B14 ²⁾ (not for 1FT613)	1 2
Connector outlet direction:	Transverse right (not for 1FT606) Transverse left (not for 1FT606) Axial NDE (not for 1FT613) Axial DE	1 2 3 4
Terminal box/ cable entry: (only for 1FT61)	Transverse/from right Transverse/from left Axial/from NDE Axial/from DE	5 6 7 8
Encoder systems for motors without DRIVE-CLiQ interface:	Incremental encoder sin/cos 1 V _{pp} , 2048 S/R Absolute encoder EnDat 2048 S/R ¹⁾ Multi-pole resolver 2-pole resolver	A E S T
Encoder systems for motors with DRIVE-CLiQ interface:	Incremental encoder 22 bit Absolute encoder, 22 bit single-turn + 12 bit multi-turn ¹⁾ 15 bit resolver 14 bit resolver	D F U P
Shaft extension:	Shaft and flange accuracy:	Holding brake:
Fitted key and keyway	Tolerance N	without
Fitted key and keyway	Tolerance N	with
Fitted key and keyway	Tolerance R	without
Fitted key and keyway	Tolerance R	with
Plain shaft	Tolerance N	without
Plain shaft	Tolerance N	with
Plain shaft	Tolerance R	without
Plain shaft	Tolerance R	with
		A B D E G H K L
Vibration magnitude:	Degree of protection:	0 1 2 6 3 4 5 7
Grade A	IP64	
Grade A	IP65	
Grade A	IP67	
Grade A	IP68	
Grade R	IP64	
Grade R	IP65	
Grade R	IP67	
Grade R	IP68	

To select the degree of protection and type, see Selection guides.

Synchronous motors

Feed motors for SINAMICS S120

1FT6 standard type motors
Natural cooling

Selection and Ordering Data

Motor type (continued)	Static current I_0 at M_0 $\Delta T=100$ K A	Calculated power P_{calc} ⁵⁾ P_{calc} for M_0 $\Delta T=100$ K kW (HP)	SINAMICS S120 Motor Module		Power cable with complete shield Motor connection (and brake connection) via power connector		
			Rated output current ⁴⁾ I_{rated} A	Booksize format Order No.	Power connector Size	Motor cable cross- section ³⁾ mm ²	Order No. Pre-assembled cable
1FT6061-6AC7...	1.9	0.84 (1.13)	3	6SL312 - - TE13 - 0AA3	1	4 x 1.5	6FX 002 - 5 S01 -
1FT6062-6AC7...	2.7	1.3 (1.74)	3	6SL312 - - TE13 - 0AA3	1	4 x 1.5	6FX 002 - 5 S01 -
1FT6064-6AC7...	4.2	2.0 (2.68)	5	6SL312 - - TE15 - 0AA3	1	4 x 1.5	6FX 002 - 5 S01 -
1FT6081-8AC7...	3.9	1.7 (2.28)	5	6SL312 - - TE15 - 0AA3	1.5	4 x 1.5	6FX 002 - 5 S21 -
1FT6082-8AC7...	6.6	2.7 (3.62)	9	6SL312 - - TE21 - 0AA3	1.5	4 x 1.5	6FX 002 - 5 S21 -
1FT6084-8AC7...	8.8	4.2 (5.63)	9	6SL312 - - TE21 - 0AA3	1.5	4 x 1.5	6FX 002 - 5 S21 -
1FT6086-8AC7...	11.3	5.7 (7.64)	18	6SL312 - - TE21 - 8AA3	1.5	4 x 1.5	6FX 002 - 5 S21 -
1FT6102-8AC7...	12.1	5.7 (7.64)	18	6SL312 - - TE21 - 8AA3	1.5	4 x 1.5	6FX 002 - 5 S21 -
1FT6105-8AC7...	21.4	10.5 (14.1)	30	6SL312 - - 1 TE23 - 0AA3	1.5	4 x 4	6FX 002 - 5 S41 -
1FT6108-8AC7...	29	14.7 (19.7)	30	6SL312 - - 1 TE23 - 0AA3	1.5	4 x 6	6FX 002 - 5 S51 -
1FT6132-6AC7...	29	15.7 (21.1)	30	6SL312 - - 1 TE23 - 0AA3	1.5	4 x 6	6FX 002 - 5 S51 -
1FT6134-6AC7...	36	19.9 (26.7)	45	6SL312 - - 1 TE24 - 5AA3	1.5	4 x 10	6FX 002 - 5 S64 -
1FT6136-6AC7...	42	24.1 (32.3)	45	6SL312 - - 1 TE24 - 5AA3	3	4 x 10	6FX 002 - 5 S14 -

Cooling:

Internal air cooling
External air cooling

0
1

Motor Module:

Single Motor Module
Double Motor Module

1
2

Type of power cable:

MOTION-CONNECT 800
MOTION-CONNECT 500

8
5

Without brake cores
With brake cores

C
D

For length code as well as power and signal cables, see Connection system MOTION-CONNECT.

....

6

¹⁾ If the absolute encoder is used, M_{rated} is reduced by 10%.

²⁾ Same flange as for IM B5 type, but with metric threaded insert in the four fixing holes.

³⁾ The current carrying capacity of the power cables complies with IEC 60204-1 for installation type C under continuous operating conditions at an ambient air temperature of 40 °C (104 °F), designed for I_0 (100 K), PVC/PUR-insulated cable.

⁴⁾ With default setting of the pulse frequency.

⁵⁾ $P_{calc} [kW] = \frac{M_0 [Nm] \times n_{rated}}{9550}$ $P_{calc} [HP] = \frac{M_0 [lb_f \cdot in] \times n_{rated}}{63000}$

Synchronous motors

Feed motors for SINAMICS S120

1FT6 standard type motors Natural cooling

Selection and Ordering Data

Rated speed	Shaft height	Rated power	Static torque	Rated torque ¹⁾	Rated current	1FT6 synchronous motors Natural cooling	Number of pole pairs	Rotor moment of inertia (without brake)	Weight (without brake)
n_{rated}	SH	P_{rated} at $\Delta T=100$ K	M_0 at $\Delta T=100$ K	M_{rated} at $\Delta T=100$ K	I_{rated} at $\Delta T=100$ K	Order No. Standard type		J	m
rpm		kW (HP)	Nm (lb _f -in)	Nm (lb _f -in)	A			10 ⁻⁴ kgm ² (10 ⁻³ x lb _f -in-s ²)	kg (lb)
3000	48	0.7 (0.94)	2.6 (23.0)	2.15 (19.0)	1.7	1FT6041 - 4AF71 - ■ ■ ■ ■ ■	2	2.9 (2.57)	6.6 (14.6)
		1.4 (1.88)	5 (44.3)	4.3 (38.1)	2.9	1FT6044 - 4AF71 - ■ ■ ■ ■ ■	2	5.1 (4.51)	8.3 (18.3)
	63	1.1 (1.48)	4 (35.4)	3.5 (31.0)	2.6	1FT6061 - 6AF71 - ■ ■ ■ ■ ■	3	6 (5.31)	8 (17.6)
		1.5 (2.01)	6 (53.1)	4.7 (41.6)	3.4	1FT6062 - 6AF71 - ■ ■ ■ ■ ■	3	8.5 (7.52)	9.5 (20.9)
		2.2 (2.95)	9.5 (84.1)	7 (62.0)	4.9	1FT6064 - 6AF71 - ■ ■ ■ ■ ■	3	13 (11.5)	12.5 (27.6)
	80	2.2 (2.95)	8 (70.8)	6.9 (61.1)	5.6	1FT6081 - 8AF71 - ■ ■ ■ ■ ■	4	21 (18.6)	12.5 (27.6)
		3.2 (4.29)	13 (115)	10.3 (91.2)	8.7	1FT6082 - 8AF71 - ■ ■ ■ ■ ■	4	30 (26.6)	15 (33.1)
		4.6 (6.17)	20 (177)	14.7 (130)	11	1FT6084 - 8AF71 - ■ ■ ■ ■ ■	4	48 (42.5)	20.5 (45.2)
		5.8 (7.78)	27 (239)	18.5 (164)	13	1FT6086 - 8AF71 - ■ ■ ■ ■ ■	4	66.5 (58.9)	25.5 (56.2)
	100	6.1 (8.18)	27 (239)	19.5 (173)	13.2	1FT6102 - 8AF71 - ■ ■ ■ ■ ■	4	99 (87.6)	27.5 (60.6)
		9.7 (13.0)	50 (443)	31 (274)	22.5	1FT6105 - 8AF71 - ■ ■ ■ ■ ■	4	168 (149)	39.5 (87.1)
		11.6 (15.6)	70 (620)	37 (327)	25	1FT6108 - 8AF71 - ■ ■ ■ ■ ■	4	260 (230)	55.5 (122)
132	11.3 (15.2)	75 (664)	36 (319)	23	1FT6132 - 6AF71 - ■ ■ ■ ■ ■	3	430 (381)	85 (187)	

Type:	IM B5 IM B14 ²⁾ (not for 1FT604/1FT613)	1 2
Connector outlet direction:	Transverse right (not for 1FT604/1FT606) Transverse left (not for 1FT604/1FT606) Axial NDE (not for 1FT613 and 1FT6 with DRIVE-CLiQ and power connector size 3) Axial DE	1 2 3 4
Terminal box/ cable entry: (only for 1FT61)	Transverse/from right Transverse/from left Axial/from NDE Axial/from DE	5 6 7 8
Encoder systems for motors without DRIVE-CLiQ interface:	Incremental encoder sin/cos 1 V _{pp1} 2048 S/R Absolute encoder EnDat 2048 S/R ¹⁾ Multi-pole resolver 2-pole resolver	A E S T
Encoder systems for motors with DRIVE-CLiQ interface:	Incremental encoder 22 bit Absolute encoder, 22 bit single-turn + 12 bit multi-turn ¹⁾ 15 bit resolver 14 bit resolver	D F U P
Shaft extension:	Shaft and flange accuracy:	Holding brake:
Fitted key and keyway	Tolerance N	without
Fitted key and keyway	Tolerance N	with
Fitted key and keyway	Tolerance R	without
Fitted key and keyway	Tolerance R	with
Plain shaft	Tolerance N	without
Plain shaft	Tolerance N	with
Plain shaft	Tolerance R	without
Plain shaft	Tolerance R	with
		A B D E G H K L
Vibration magnitude:	Degree of protection:	0 1 2 6 3 4 5 7
Grade A	IP64	
Grade A	IP65	
Grade A	IP67	
Grade A	IP68	
Grade R	IP64	
Grade R	IP65	
Grade R	IP67	
Grade R	IP68	

To select the degree of protection and type, see Selection guides.

Synchronous motors

Feed motors for SINAMICS S120

1FT6 standard type motors
Natural cooling

Selection and Ordering Data

Motor type (continued)	Static current I_0 at M_0 $\Delta T=100$ K A	Calculated power $P_{calc}^{6)}$ P_{calc} for M_0 $\Delta T=100$ K kW (HP)	SINAMICS S120 Motor Module		Power cable with complete shield Motor connection (and brake connection) via power connector		
			Rated output current ⁵⁾ I_{rated} A	Booksized format Order No.	Power connector Size	Motor cable cross- section ⁴⁾ mm ²	Order No. Pre-assembled cable
1FT6041-4AF7...	1.9	0.8 (1.07)	3	6SL312 - TE13 - 0AA3	1	4 x 1.5	6FX 002 - 5S01 -
1FT6044-4AF7...	3	1.6 (2.15)	3	6SL312 - TE13 - 0AA3	1	4 x 1.5	6FX 002 - 5S01 -
1FT6061-6AF7...	2.7	1.3 (1.74)	3	6SL312 - TE13 - 0AA3	1	4 x 1.5	6FX 002 - 5S01 -
1FT6062-6AF7...	4.1	1.9 (2.55)	5	6SL312 - TE15 - 0AA3	1	4 x 1.5	6FX 002 - 5S01 -
1FT6064-6AF7...	6.1	3.0 (4.02)	9	6SL312 - TE21 - 0AA3	1	4 x 1.5	6FX 002 - 5S01 -
1FT6081-8AF7...	5.8	2.5 (3.35)	9	6SL312 - TE21 - 0AA3	1.5	4 x 1.5	6FX 002 - 5S21 -
1FT6082-8AF7...	9.6	4.1 (5.50)	18	6SL312 - TE21 - 8AA3	1.5	4 x 1.5	6FX 002 - 5S21 -
1FT6084-8AF7...	13.2	6.3 (8.45)	18	6SL312 - TE21 - 8AA3	1.5	4 x 1.5	6FX 002 - 5S21 -
1FT6086-8AF7...	16.4	8.5 (11.4)	18	6SL312 - TE21 - 8AA3	1.5	4 x 2.5	6FX 002 - 5S31 -
1FT6102-8AF7...	16.9	8.5 (11.4)	18	6SL312 - TE21 - 8AA3	1.5	4 x 2.5	6FX 002 - 5S31 -
1FT6105-8AF7...	32	15.7 (21.1)	30 ³⁾	6SL312 - 1 TE23 - 0AA3	1.5	4 x 10	6FX 002 - 5S61 -
1FT6108-8AF7...	41	22.0 (29.5)	45	6SL312 - 1 TE24 - 5AA3	3	4 x 10	6FX 002 - 5S14 -
1FT6132-6AF7...	43	23.6 (31.6)	45	6SL312 - 1 TE24 - 5AA3	3	4 x 10	6FX 002 - 5S14 -
Cooling:							
Internal air cooling					0		
External air cooling					1		
Motor Module:							
Single Motor Module					1		
Double Motor Module					2		
Type of power cable:							
MOTION-CONNECT 800						8	
MOTION-CONNECT 500						5	
Without brake cores							C
With brake cores							D
For length code as well as power and signal cables, see Connection system MOTION-CONNECT.						

6

¹⁾ If the absolute encoder is used, M_{rated} is reduced by 10%.

²⁾ Same flange as for IM B5 type, but with metric threaded insert in the four fixing holes.

³⁾ With the specified Motor Module, the motor cannot be fully utilized with M_0 at $\Delta T = 100$ K winding temperature rise. If a Motor Module with a higher rating is used, you must check whether the specified power cable can be connected to it.

⁴⁾ The current carrying capacity of the power cables complies with IEC 60204-1 for installation type C under continuous operating conditions at an ambient air temperature of 40 °C (104 °F), designed for I_0 (100 K), PVC/PUR-insulated cable.

⁵⁾ With default setting of the pulse frequency.

⁶⁾ $P_{calc} [kW] = \frac{M_0 [Nm] \times n_{rated}}{9550}$ $P_{calc} [HP] = \frac{M_0 [lb_f-in] \times n_{rated}}{63000}$

Synchronous motors

Feed motors for SINAMICS S120

1FT6 standard type motors Natural cooling

Selection and Ordering Data									
Rated speed	Shaft height	Rated power	Static torque	Rated torque ¹⁾	Rated current	1FT6 synchronous motors Natural cooling	Number of pole pairs	Rotor moment of inertia (without brake)	Weight (without brake)
n_{rated}	SH	P_{rated} at $\Delta T=100\text{ K}$	M_0 at $\Delta T=100\text{ K}$	M_{rated} at $\Delta T=100\text{ K}$	I_{rated} at $\Delta T=100\text{ K}$	Order No. Standard type		J	m
rpm		kW (HP)	Nm (lb _f -in)	Nm (lb _f -in)	A			10^{-4} kgm^2 ($10^{-3}\text{ x lb}_f\text{-in-s}^2$)	kg (lb)
4500	63	1.4 (1.88)	4 (35.4)	2.9 (25.7)	3.4	1FT6061 - 6AH7 ■ - ■ ■ ■ ■ ■	3	6 (5.31)	8 (17.6)
		1.7 (2.28)	6 (53.1)	3.6 (31.9)	3.9	1FT6062 - 6AH7 ■ - ■ ■ ■ ■ ■	3	8.5 (7.52)	9.5 (20.9)
		2.3 (3.08)	9.5 (84.1)	4.8 (42.5)	5.5	1FT6064 - 6AH7 ■ - ■ ■ ■ ■ ■	3	13 (11.5)	12.5 (27.6)
	80	2.7 (3.62)	8 (70.8)	5.8 (51.3)	7.3	1FT6081 - 8AH7 ■ - ■ ■ ■ ■ ■	4	21 (18.6)	12.5 (27.6)
		4 (5.36)	13 (115)	8.5 (75.2)	11	1FT6082 - 8AH7 ■ - ■ ■ ■ ■ ■	4	30 (26.6)	15 (33.1)
		4.9 (6.57)	20 (177)	10.5 (92.9)	12.5	1FT6084 - 8AH7 ■ - ■ ■ ■ ■ ■	4	48 (42.5)	20.5 (45.2)
		5.7 (7.64)	27 (239)	12 (106)	12.6	1FT6086 - 8AH7 ■ - ■ ■ ■ ■ ■	4	66.5 (58.9)	25.5 (56.2)
	100	5.7 (7.64)	27 (239)	12 (106)	12	1FT6102 - 8AH7 ■ - ■ ■ ■ ■ ■	4	99 (87.6)	27.5 (60.6)
	Type:		IM B5 IM B14 ²⁾				1		
						2			
Connector outlet direction:		Transverse right (not for 1FT606) Transverse left (not for 1FT606) Axial NDE Axial DE				1			
						2			
						3			
						4			
Terminal box/ cable entry: (only for 1FT61)		Transverse/from right Transverse/from left Axial/from NDE Axial/from DE				5			
						6			
						7			
						8			
Encoder systems for motors without DRIVE-CLiQ interface:		Incremental encoder sin/cos 1 V _{pp} 2048 S/R Absolute encoder EnDat 2048 S/R ¹⁾ Multi-pole resolver 2-pole resolver				A			
						E			
						S			
						T			
Encoder systems for motors with DRIVE-CLiQ interface:		Incremental encoder 22 bit Absolute encoder, 22 bit single-turn + 12 bit multi-turn ¹⁾ 15 bit resolver 14 bit resolver				D			
						F			
						U			
						P			
Shaft extension:		Shaft and flange accuracy:		Holding brake:		A			
Fitted key and keyway		Tolerance N		without		B			
Fitted key and keyway		Tolerance N		with					
Fitted key and keyway		Tolerance R		without		D			
Fitted key and keyway		Tolerance R		with		E			
Plain shaft		Tolerance N		without		G			
Plain shaft		Tolerance N		with		H			
Plain shaft		Tolerance R		without		K			
Plain shaft		Tolerance R		with		L			
Vibration magnitude:		Degree of protection:				0			
Grade A		IP64				1			
Grade A		IP65				2			
Grade A		IP67				6			
Grade A		IP68				6			
Grade R		IP64				3			
Grade R		IP65				4			
Grade R		IP67				5			
Grade R		IP68				7			

To select the degree of protection and type, see Selection guides.

Synchronous motors

Feed motors for SINAMICS S120

1FT6 standard type motors
Natural cooling

Selection and Ordering Data

Motor type (continued)	Static current I_0 at M_0 $\Delta T = 100$ K A	Calculated power P_{calc} ⁶⁾ P_{calc} for M_0 $\Delta T = 100$ K kW (HP)	SINAMICS S120 Motor Module		Power cable with complete shield Motor connection (and brake connection) via power connector		
			Rated output current ⁵⁾ I_{rated} A	Booksize format Order No.	Power connector Size	Motor cable cross-section ⁴⁾ mm ²	Order No. Pre-assembled cable
1FT6061-6AH7...	4	1.9 (2.55)	5	6SL312 - TE15 - 0AA3	1	4 x 1.5	6FX 002 - 5 S01 -
1FT6062-6AH7...	5.7	2.8 (3.75)	9	6SL312 - TE21 - 0AA3	1	4 x 1.5	6FX 002 - 5 S01 -
1FT6064-6AH7...	9.0	4.5 (6.03)	9	6SL312 - TE21 - 0AA3	1	4 x 1.5	6FX 002 - 5 S01 -
1FT6081-8AH7...	8.6	3.8 (5.10)	9	6SL312 - TE21 - 0AA3	1.5	4 x 1.5	6FX 002 - 5 S21 -
1FT6082-8AH7...	14.8	6.1 (8.18)	18	6SL312 - TE21 - 8AA3	1.5	4 x 1.5	6FX 002 - 5 S21 -
1FT6084-8AH7...	19.8	9.4 (12.6)	18 ³⁾	6SL312 - TE21 - 8AA3	1.5	4 x 4	6FX 002 - 5 S41 -
1FT6086-8AH7...	23.3	12.7 (17.0)	30	6SL312 - 1TE23 - 0AA3	1.5	4 x 4	6FX 002 - 5 S41 -
1FT6102-8AH7...	24.1	12.7 (17.0)	30	6SL312 - 1TE23 - 0AA3	1.5	4 x 4	6FX 002 - 5 S41 -
Cooling:							
Internal air cooling					0		
External air cooling					1		
Motor Module:							
Single Motor Module					1		
Double Motor Module					2		
Type of power cable:							
MOTION-CONNECT 800						8	
MOTION-CONNECT 500						5	
Without brake cores							C
With brake cores							D
For length code as well as power and signal cables, see Connection system MOTION-CONNECT.						

6

¹⁾ If the absolute encoder is used, M_{rated} is reduced by 10%.

²⁾ Same flange as for IM B5 type, but with metric threaded insert in the four fixing holes.

³⁾ With the specified Motor Module, the motor cannot be fully utilized with M_0 at $\Delta T = 100$ K winding temperature rise. If a Motor Module with a higher rating is used, you must check whether the specified power cable can be connected to it.

⁴⁾ The current carrying capacity of the power cables complies with IEC 60204-1 for installation type C under continuous operating conditions at an ambient air temperature of 40 °C (104 °F), designed for I_0 (100 K), PVC/PUR-insulated cable.

⁵⁾ With default setting of the pulse frequency.

⁶⁾ P_{calc} [kW] = $\frac{M_0$ [Nm] \times n_{rated} }{9550} P_{calc} [HP] = $\frac{M_0$ [lb_f-in] \times n_{rated} }{63000}

Synchronous motors

Feed motors for SINAMICS S120

1FT6 standard type motors Natural cooling

Selection and Ordering Data

Rated speed	Shaft height	Rated power	Static torque	Rated torque ¹⁾	Rated current	1FT6 synchronous motors Natural cooling	Number of pole pairs	Rotor moment of inertia (without brake)	Weight (without brake)
n_{rated}	SH	P_{rated} at $\Delta T=100$ K	M_0 at $\Delta T=100$ K	M_{rated} at $\Delta T=100$ K	I_{rated} at $\Delta T=100$ K	Order No. Standard type		J	m
rpm		kW (HP)	Nm (lb _f -in)	Nm (lb _f -in)	A			10 ⁻⁴ kgm ² (10 ⁻³ x lb _f -in-s ²)	kg (lb)
6000	28	0.19 (0.25)	0.4 (3.54)	0.3 (2.66)	1.1	1FT6021 - 6AK71 - ■■■■	3	0.21 (0.19)	1.2 (2.65)
		0.31 (0.42)	0.8 (7.08)	0.5 (4.43)	0.9	1FT6024 - 6AK71 - ■■■■	3	0.34 (0.30)	2.1 (4.63)
	36	0.47 (0.63)	1 (8.85)	0.75 (6.64)	1.2	1FT6031 - 4AK71 - ■■■■	2	0.65 (0.58)	3.1 (6.84)
		0.88 (1.18)	2 (17.7)	1.4 (12.4)	2.1	1FT6034 - 4AK71 - ■■■■	2	1.1 (0.97)	4.4 (9.70)
	48	1.1 (1.48)	2.6 (23.0)	1.7 (15.0)	2.4	1FT6041 - 4AK71 - ■■■■	2	2.9 (2.57)	6.6 (14.6)
		1.9 (2.55)	5 (44.3)	3 (26.6)	4.1	1FT6044 - 4AK71 - ■■■■	2	5.1 (4.51)	8.3 (18.3)
	63	1.3 (1.74)	4 (35.4)	2.1 (18.6)	3.1	1FT6061 - 6AK71 - ■■■■	3	6 (5.31)	8 (17.6)
			6 (53.1)	2.1 (18.6)	3.2	1FT6062 - 6AK71 - ■■■■	3	8.5 (7.52)	9.5 (20.9)
		1.3 (1.74)	9.5 (84.1)	2.1 (18.6)	3.5	1FT6064 - 6AK71 - ■■■■	3	13 (11.5)	12.5 (27.6)
	80	2.9 (3.89)	8 (70.8)	4.6 (40.7)	7.7	1FT6081 - 8AK71 - ■■■■	4	21 (18.6)	12.5 (27.6)
13 (115)			5.5 (48.7)	9.1	1FT6082 - 8AK71 - ■■■■	4	30 (26.6)	15 (33.1)	
4.1 (5.50)		20 (177)	6.5 (57.5)	9.2	1FT6084 - 8AK71 - ■■■■	4	48 (42.5)	20.5 (45.2)	

Type:	IM B5 IM B14 ²⁾ (not for 1FT602/1FT603/1FT604)	1 2
Connector outlet direction:	Transverse right (not for 1FT603/1FT604/1FT606) Transverse left (not for 1FT603/1FT604/1FT606) Axial NDE Axial DE	1 2 3 4
Encoder systems for motors without DRIVE-CLiQ interface:	Incremental encoder sin/cos 1 V _{pp} 2048 S/R Absolute encoder EnDat 2048 S/R (not for 1FT602) ¹⁾ Absolute encoder EnDat 512 S/R (only for 1FT602) ¹⁾ Multi-pole resolver 2-pole resolver	A E H S T
Encoder systems for motors with DRIVE-CLiQ interface:	Incremental encoder 22 bit Absolute encoder, 22 bit single-turn + 12 bit multi-turn ¹⁾ (not for 1FT602) Absolute encoder, 20 bit single-turn + 12 bit multi-turn ¹⁾ (only for 1FT602) 15 bit resolver 14 bit resolver	D F L U P
Shaft extension:	Shaft and flange accuracy:	Holding brake:
Fitted key and keyway	Tolerance N	without
Fitted key and keyway	Tolerance N	with
Fitted key and keyway	Tolerance R	without
Fitted key and keyway	Tolerance R	with
Plain shaft	Tolerance N	without
Plain shaft	Tolerance N	with
Plain shaft	Tolerance R	without
Plain shaft	Tolerance R	with
Vibration magnitude:	Degree of protection:	
Grade A	IP64	0
Grade A	IP65 (not for 1FT602)	1
Grade A	IP67	2
Grade A	IP68 (not for 1FT602)	6
Grade R	IP64	3
Grade R	IP65 (not for 1FT602)	4
Grade R	IP67	5
Grade R	IP68 (not for 1FT602)	7

To select the degree of protection and type, see Selection guides.

Synchronous motors

Feed motors for SINAMICS S120

1FT6 standard type motors
Natural cooling

Selection and Ordering Data

Motor type (continued)	Static current I_0 at M_0 $\Delta T=100$ K A	Calculated power $P_{calc}^{5)}$ P_{calc} for M_0 $\Delta T=100$ K kW (HP)	SINAMICS S120 Motor Module		Power cable with complete shield		
			Rated output current ⁴⁾ I_{rated} A	Booksized format Order No.	Motor connection (and brake connection) via power connector		
					Power connector	Motor cable cross-section ³⁾ mm ²	Order No. Pre-assembled cable
					Size		
1FT6021-6AK7 ...	1.25	0.3 (0.40)	3	6SL312 - TE13 - 0AA3	1	4 x 1.5	6FX 002 - 5 S01 -
1FT6024-6AK7 ...	1.25	0.5 (0.67)	3	6SL312 - TE13 - 0AA3	1	4 x 1.5	6FX 002 - 5 S01 -
1FT6031-4AK7 ...	1.4	0.6 (0.80)	3	6SL312 - TE13 - 0AA3	1	4 x 1.5	6FX 002 - 5 S01 -
1FT6034-4AK7 ...	2.6	1.3 (1.74)	3	6SL312 - TE13 - 0AA3	1	4 x 1.5	6FX 002 - 5 S01 -
1FT6041-4AK7 ...	3	1.6 (2.15)	3	6SL312 - TE13 - 0AA3	1	4 x 1.5	6FX 002 - 5 S01 -
1FT6044-4AK7 ...	5.9	3.1 (4.16)	9	6SL312 - TE21 - 0AA3	1	4 x 1.5	6FX 002 - 5 S01 -
1FT6061-6AK7...	5	2.5 (3.35)	5	6SL312 - TE15 - 0AA3	1	4 x 1.5	6FX 002 - 5 S01 -
1FT6062-6AK7...	7.6	3.8 (5.10)	9	6SL312 - TE21 - 0AA3	1	4 x 1.5	6FX 002 - 5 S01 -
1FT6064-6AK7...	12	4.0 (5.36)	18	6SL312 - TE21 - 8AA3	1	4 x 1.5	6FX 002 - 5 S01 -
1FT6081-8AK7...	11.1	5.0 (6.71)	18	6SL312 - TE21 - 8AA3	1.5	4 x 1.5	6FX 002 - 5 S21 -
1FT6082-8AK7...	17.3	8.2 (11.0)	18	6SL312 - TE21 - 8AA3	1.5	4 x 2.5	6FX 002 - 5 S31 -
1FT6084-8AK7...	24.1	12.6 (16.9)	30	6SL312 - 1 TE23 - 0AA3	1.5	4 x 4	6FX 002 - 5 S41 -
Cooling:							
Internal air cooling					0		
External air cooling					1		
Motor Module:							
Single Motor Module					1		
Double Motor Module					2		
Type of power cable:							
MOTION-CONNECT 800						8	
MOTION-CONNECT 500						5	
Without brake cores							C
With brake cores							D
For length code as well as power and signal cables, see Connection system MOTION-CONNECT.						

6

¹⁾ If the absolute encoder is used, M_{rated} is reduced by 10%.

²⁾ Same flange as for IM B5 type, but with metric threaded insert in the four fixing holes.

³⁾ The current carrying capacity of the power cables complies with IEC 60204-1 for installation type C under continuous operating conditions at an ambient air temperature of 40 °C (104 °F), designed for I_0 (100 K), PVC/PUR-insulated cable.

⁴⁾ With default setting of the pulse frequency.

⁵⁾ $P_{calc} [kW] = \frac{M_0 [Nm] \times n_{rated}}{9550}$ $P_{calc} [HP] = \frac{M_0 [lb_f-in] \times n_{rated}}{63000}$

Synchronous motors

Feed motors for SINAMICS S120

1FT6 standard type motors Forced ventilation

Selection and Ordering Data

Rated speed	Shaft height	Rated power	Static torque	Rated torque ¹⁾	Rated current	1FT6 synchronous motors Forced ventilation ²⁾	Number of pole pairs	Rotor moment of inertia (without brake)	Weight (without brake)
n_{rated}	SH	P_{rated} at $\Delta T=100$ K	M_0 at $\Delta T=100$ K	M_{rated} at $\Delta T=100$ K	I_{rated} at $\Delta T=100$ K	Order No. Standard type		J	m
rpm		kW (HP)	Nm (lb _f -in)	Nm (lb _f -in)	A			10 ⁻⁴ kgm ² (10 ⁻³ x lb _f -in-s ²)	kg (lb)
1500	100	9.3 (12.5)	65 (575)	59 (522)	21.7	1FT6105 - 8SB7 - ■■■■	4	168 (149)	45.5 (100)
		13 (17.4)	90 (797)	83 (735)	31	1FT6108 - 8SB7 - ■■■■	4	260 (230)	61.5 (136)
	132	16 (21.5)	110 (974)	102 (903)	36	1FT6132 - 6SB71 - ■■■■	3	430 (381)	91 (201)
		20.4 (27.4)	140 (1239)	130 (1151)	45	1FT6134 - 6SB71 - ■■■■	3	547 (484)	106 (234)
2000	100	11.7 (15.7)	65 (575)	56 (496)	28	1FT6105 - 8SC7 - ■■■■	4	168 (149)	45.5 (100)
		16.8 (22.5)	90 (797)	80 (708)	40	1FT6108 - 8SC7 - ■■■■	4	260 (230)	61.5 (136)
	132	20.5 (27.5)	110 (974)	98 (867)	46	1FT6132 - 6SC71 - ■■■■	3	430 (381)	91 (201)
		26.2 (35.1)	140 (1239)	125 (1106)	57	1FT6134 - 6SC71 - ■■■■	3	547 (484)	106 (234)
		32.5 (43.6)	175 (1549)	155 (1372)	72	1FT6136 - 6SC71 - ■■■■	3	664 (588)	123 (271)

Type:	IM B5 IM B14 ³⁾ (not for 1FT613)	1 2
Connector outlet direction:	Transverse right Transverse left Axial NDE (not for 1FT613 and not for 1FT6 with DRIVE-CLiQ and power connector size 3) Axial DE	1 2 3 4
Terminal box/ cable entry:	Transverse/from right Transverse/from left Axial/from NDE Axial/from DE	5 6 7 8
Encoder systems for motors without DRIVE-CLiQ interface:	Incremental encoder sin/cos 1 V _{pp} , 2048 S/R Absolute encoder EnDat 2048 S/R ¹⁾ Multi-pole resolver 2-pole resolver	A E S T
Encoder systems for motors with DRIVE-CLiQ interface:	Incremental encoder 22 bit Absolute encoder, 22 bit single-turn + 12 bit multi-turn ¹⁾ 15 bit resolver 14 bit resolver	D F U P
Shaft extension:	Shaft and flange accuracy:	Holding brake:
Fitted key and keyway	Tolerance N	without
Fitted key and keyway	Tolerance N	with
Fitted key and keyway	Tolerance R	without
Fitted key and keyway	Tolerance R	with
Plain shaft	Tolerance N	without
Plain shaft	Tolerance N	with
Plain shaft	Tolerance R	without
Plain shaft	Tolerance R	with
		A B D E G H K L
Vibration magnitude:	Degree of protection:⁴⁾	0 1 3 4
Grade A	IP64	
Grade A	IP65	
Grade R	IP64	
Grade R	IP65	

To select the degree of protection and type, see Selection guides.

Synchronous motors

Feed motors for SINAMICS S120

1FT6 standard type motors
Forced ventilation

Selection and Ordering Data

Motor type (continued)	Static current I_0 at M_0 $\Delta T=100$ K A	Calculated power P_{calc} ⁷⁾ P_{calc} for M_0 $\Delta T=100$ K kW (HP)	SINAMICS S120 Motor Module		Power cable with complete shield Motor connection (and brake connection) via power connector		
			Rated output current ⁶⁾ I_{rated} A	Booksize format Order No.	Power connector Size	Motor cable cross-section ⁵⁾ mm ²	Order No. Pre-assembled cable
1FT6105-8SB7...	21.9	10.2 (13.7)	30	6SL312 - 1TE23 - 0AA3	1.5	4 x 4	6FX 002 - 5S41 -
1FT6108-8SB7...	30	14.1 (18.9)	30	6SL312 - 1TE23 - 0AA3	1.5	4 x 6	6FX 002 - 5S51 -
1FT6132-6SB7...	36	17.3 (23.2)	45	6SL312 - 1TE24 - 5AA3	3	4 x 10	6FX 002 - 5S14 -
1FT6134-6SB7...	44	22.0 (29.5)	60	6SL312 - 1TE26 - 0AA3	3	4 x 10	6FX 002 - 5S14 -
1FT6136-6SB7...	55	27.5 (36.9)	60	6SL312 - 1TE26 - 0AA3	3	4 x 16	6FX 002 - 5S23 -
1FT6105-8SC7...	30	13.6 (18.2)	30	6SL312 - 1TE23 - 0AA3	1.5	4 x 6	6FX 002 - 5S51 -
1FT6108-8SC7...	41	18.8 (25.2)	45	6SL312 - 1TE24 - 5AA3	3	4 x 10	6FX 002 - 5S14 -
1FT6132-6SC7...	47	23.0 (30.8)	60	6SL312 - 1TE26 - 0AA3	3	4 x 10	6FX 002 - 5S14 -
1FT6134-6SC7...	58	29.3 (39.3)	60	6SL312 - 1TE26 - 0AA3	3	4 x 16	6FX 002 - 5S23 -
1FT6136-6SC7...	77	36.6 (49.1)	85	6SL312 - 1TE28 - 5AA3	3	4 x 25	6FX 002 - 5DS33 -
Cooling: Internal air cooling External air cooling				0 1			
Motor Module: Single Motor Module				1			
Type of power cable: MOTION-CONNECT 800 MOTION-CONNECT 500						8 5	
Without brake cores With brake cores							C D
For length code as well as power and signal cables, see Connection system MOTION-CONNECT.						

Notes on forced ventilation

	Shaft heights SH 80 and SH 100	Shaft height SH 132
Direction of air flow	From NDE to DE	From DE to NDE
Connection system	Connector size 1	Terminal box
Type of connecting cable	6FX.002-5CA01-....	6FX.008-1BB11-....
Pin and terminal assignment	Pin 1: L1, Pin 2: N	U1/L1: V2/L2: W3/L3
Supply voltage	220/260 V 1 AC, 50/60 Hz	400/460 V 3 AC, 50/60 Hz
Max. fan current	0.3 A	0.4 A
Weight of the fan module, approx.	4.8 kg (10.6 lb)	5.6 kg (12.3 lb)
Sound pressure level	70 dB (A)	74 dB (A)

¹⁾ If the absolute encoder is used, M_{rated} is reduced by 10%.

²⁾ Not for use in environments containing electrically conductive dust. Forced ventilation cannot be used if flammable, chemically aggressive, electrically-conductive or explosive dust is present.

³⁾ Same flange as for IM B5 type, but with metric threaded insert in the four fixing holes.

⁴⁾ The degree of protection refers to the motor. The built-on fan meets the requirements of degree of protection IP54.

⁵⁾ The current carrying capacity of the power cables complies with IEC 60204-1 for installation type C under continuous operating conditions at an ambient air temperature of 40 °C (104 °F), designed for I_0 (100 K), PVC/PUR-insulated cable.

⁶⁾ With default setting of the pulse frequency.

⁷⁾ $P_{calc} [kW] = \frac{M_0 [Nm] \times n_{rated}}{9550}$ $P_{calc} [HP] = \frac{M_0 [lb_f-in] \times n_{rated}}{63000}$

Synchronous motors

Feed motors for SINAMICS S120

1FT6 standard type motors Forced ventilation

Selection and Ordering Data

Rated speed	Shaft height	Rated power	Static torque	Rated torque ¹⁾	Rated current	1FT6 synchronous motors Forced ventilation ²⁾	Number of pole pairs	Rotor moment of inertia (without brake)	Weight (without brake)
n_{rated}	SH	P_{rated} at $\Delta T=100$ K	M_0 at $\Delta T=100$ K	M_{rated} at $\Delta T=100$ K	I_{rated} at $\Delta T=100$ K	Order No. Standard type		J	m
rpm		kW (HP)	Nm (lb _f -in)	Nm (lb _f -in)	A			10^{-4} kgm ² (10^{-3} x lb _f -in-s ²)	kg (lb)
3000	80	6.9 (9.25)	26 (230)	22 (195)	17	1FT6084 - 8SF7 - ■■■■	4	48 (42.5)	25 (55.1)
		9.7 (13.0)	35 (310)	31 (274)	24.5	1FT6086 - 8SF7 - ■■■■	4	66.5 (58.9)	30 (66.2)
	100	15.7 (21.1)	65 (575)	50 (443)	35	1FT6105 - 8SF7 - ■■■■	4	168 (149)	45.5 (100)
		22 (29.5)	90 (797)	70 (620)	53	1FT6108 - 8SF7 - ■■■■	4	260 (230)	61.5 (136)
		28.3 (38.0)	110 (974)	90 (797)	62	1FT6132 - 6SF71 - ■■■■	3	430 (381)	91 (201)
		34.6 (46.4)	140 (1239)	110 (974)	72	1FT6134 - 6SF71 - ■■■■	3	547 (484)	106 (234)
132	45.5 (61.0)	175 (1549)	145 (1283)	104	1FT6136 - 6SF71 - ■■■■	3	664 (588)	123 (271)	
	4500	9.4 (12.6)	26 (230)	20 (177)	24.5	1FT6084 - 8SH7 - ■■■■	4	48 (42.5)	25 (55.1)
80		12.7 (17.0)	35 (310)	27 (239)	31.5	1FT6086 - 8SH7 - ■■■■	4	66.5 (58.9)	30 (66.2)
	100	18.8 (25.2)	65 (575)	40 (354)	41	1FT6105 - 8SH7 - ■■■■	4	168 (149)	45.5 (100)
6000		80	10.7 (14.3)	26 (230)	17 (150)	25.5	1FT6084 - 8SK7 - ■■■■	4	48 (42.5)
	13.8 (18.5)		35 (310)	22 (195)	29	1FT6086 - 8SK7 - ■■■■	4	66.5 (58.9)	30 (66.2)

Type:	IM B5 IM B14 ³⁾ (not for 1FT613)	1 2
Connector outlet direction (not for 1FT6136-6SF71):	Transverse right Transverse left Axial NDE (not for 1FT613 and not for 1FT6 with DRIVE-CLiQ and power connector size 3) Axial DE	1 2 3 4
Terminal box/ cable entry: (only for 1FT61)	Transverse/from right Transverse/from left Axial/from NDE Axial/from DE	5 6 7 8
Encoder systems for motors without DRIVE-CLiQ interface:	Incremental encoder sin/cos 1 V _{pp} 2048 S/R Absolute encoder EnDat 2048 S/R ¹⁾ Multi-pole resolver 2-pole resolver	A E S T
Encoder systems for motors with DRIVE-CLiQ interface:	Incremental encoder 22 bit Absolute encoder, 22 bit single-turn + 12 bit multi-turn ¹⁾ 15 bit resolver 14 bit resolver	D F U P
Shaft extension: Fitted key and keyway Fitted key and keyway Fitted key and keyway Plain shaft Plain shaft Plain shaft Plain shaft	Shaft and flange accuracy: Tolerance N Tolerance N Tolerance R Tolerance R Tolerance N Tolerance N Tolerance R Tolerance R	Holding brake: without with without with without with without with
		A B D E G H K L
Vibration magnitude: Grade A Grade A Grade R Grade R	Degree of protection:⁴⁾ IP64 IP65 IP64 IP65	0 1 3 4

To select the degree of protection and type, see Selection guides.



Synchronous motors

Feed motors for SINAMICS S120

1FT6 standard type motors
Forced ventilation
Selection and Ordering Data

Motor type (continued)	Static current I_0 at M_0 $\Delta T = 100$ K	Calculated power P_{calc} ⁸⁾ P_{calc} for M_0 $\Delta T = 100$ K kW (HP)	SINAMICS S120 Motor Module		Power cable with complete shield Motor connection (and brake connection) via power connector		
			Rated output current ⁷⁾ I_{rated} A	Booksized format Order No.	Power connector Size	Motor cable cross- section ⁶⁾ mm ²	Order No. Pre-assembled cable
1FT6084-8SF7...	18.2	8.2 (11.0)	18 ⁵⁾	6SL312 - 1TE21 - 8AA3	1.5	4 x 2.5	6FX 002 - 5S31 -
1FT6086-8SF7...	25	11.0 (14.8)	30	6SL312 - 1TE23 - 0AA3	1.5	4 x 4	6FX 002 - 5S41 -
1FT6105-8SF7...	42	20.4 (27.4)	45	6SL312 - 1TE24 - 5AA3	3	4 x 10	6FX 002 - 5S14 -
1FT6108-8SF7...	62	28.3 (38.0)	60 ⁵⁾	6SL312 - 1TE26 - 0AA3	3	4 x 16	6FX 002 - 5S23 -
1FT6132-6SF7...	69	34.6 (46.4)	85	6SL312 - 1TE28 - 5AA3	3	4 x 25	6FX 002 - 5DS33 -
1FT6134-6SF7...	83	44.0 (59.0)	85	6SL312 - 1TE28 - 5AA3	3	4 x 25	6FX 002 - 5DS33 -
1FT6136-6SF7...	110	55 (73.8)	132	6SL312 - 1TE31 - 3AA3	Terminal box (max. 4 x 3.5)		
1FT6084-8SH7...	26	12.3 (16.5)	30	6SL312 - 1TE23 - 0AA3	1.5	4 x 4	6FX 002 - 5S41 -
1FT6086-8SH7...	38	16.5 (22.1)	45	6SL312 - 1TE24 - 5AA3	3	4 x 10	6FX 002 - 5S14 -
1FT6105-8SH7...	59	30.6 (41.0)	85	6SL312 - 1TE28 - 5AA3	3	4 x 16	6FX 002 - 5S23 -
1FT6084-8SK7...	35	16.3 (21.9)	45	6SL312 - 1TE24 - 5AA3	1.5	4 x 10	6FX 002 - 5S64 -
1FT6086-8SK7...	44	22.0 (29.5)	45	6SL312 - 1TE24 - 5AA3	3	4 x 10	6FX 002 - 5S14 -

Cooling:

 Internal air cooling
 External air cooling

 0
 1

Motor Module:

 Single Motor Module
 Double Motor Module

 1
 2

Type of power cable:

 MOTION-CONNECT 800
 MOTION-CONNECT 500

 8
 5

 Without brake cores
 With brake cores

 C
 D

For length code as well as power and signal cables, see Connection system MOTION-CONNECT.

....

Notes on forced ventilation

	Shaft heights SH 80 and SH 100	Shaft height SH 132
Direction of air flow	From NDE to DE	From DE to NDE
Connection system	Connector size 1	Terminal box
Type of connecting cable	6FX.002-5CA01-....	6FX.008-1BB11-....
Pin and terminal assignment	Pin 1: L1, Pin 2: N	U1/L1: V2/L2: W3/L3
Supply voltage	220/260 V 1 AC, 50/60 Hz	400/460 V 3 AC, 50/60 Hz
Max. fan current	0.3 A	0.4 A
Weight of the fan module, approx.	4.8 kg (10.6 lb)	5.6 kg (12.3 lb)
Sound pressure level	70 dB (A)	74 dB (A)

¹⁾ If the absolute encoder is used, M_{rated} is reduced by 10%.

²⁾ Not for use in environments containing electrically conductive dust. Forced ventilation cannot be used if flammable, chemically aggressive, electrically-conductive or explosive dust is present.

³⁾ Same flange as for IM B5 type, but with metric threaded insert in the four fixing holes.

⁴⁾ The degree of protection refers to the motor. The built-on fan meets the requirements of degree of protection IP54.

⁵⁾ With the specified Motor Module, the motor cannot be fully utilized with M_0 at $\Delta T = 100$ K winding temperature rise. If a Motor Module with a higher rating is used, you must check whether the specified power cable can be connected to it.

⁶⁾ The current carrying capacity of the power cables complies with IEC 60204-1 for installation type C under continuous operating conditions at an ambient air temperature of 40 °C (104 °F), designed for I_0 (100 K), PVC/PUR-insulated cable.

⁷⁾ With default setting of the pulse frequency.

⁸⁾ $P_{calc} [kW] = \frac{M_0 [Nm] \times n_{rated}}{9550}$ $P_{calc} [HP] = \frac{M_0 [lb_f \cdot in] \times n_{rated}}{63000}$

Synchronous motors

Feed motors for SINAMICS S120

1FT6 standard type motors Water cooling

Selection and Ordering Data

Rated speed	Shaft height	Rated power	Static torque	Rated torque	Rated current	1FT6 synchronous motors Water cooling ¹⁾²⁾	Number of pole pairs	Rotor moment of inertia (without brake)	Weight (without brake)
n_{rated}	SH	P_{rated} at $\Delta T=100\text{ K}$	M_0 at $\Delta T=100\text{ K}$	M_{rated} at $\Delta T=100\text{ K}$	I_{rated} at $\Delta T=100\text{ K}$	Order No. Standard type		J	m
rpm		kW (HP)	Nm (lb _f -in)	Nm (lb _f -in)	A			10^{-4} kgm^2 ($10^{-3}\text{ x lb}_f\text{-in-s}^2$)	kg (lb)
1500	100	18.2 (24.4)	119 (1053)	116 (1027)	43	1FT6108 - 8WB7 - ■ ■ ■ ■ ■	4	260 (230)	61.5 (136)
2000	100	17.2 (23.1)	85 (752)	82 (726)	60	1FT6105 - 8WC7 - ■ ■ ■ ■ ■	4	168 (149)	45.5 (100)
		24.1 (32.3)	119 (1053)	115 (1018)	57	1FT6108 - 8WC7 - ■ ■ ■ ■ ■	4	260 (230)	61.5 (136)
3000	63	3.2 (4.29)	10.2 (90.3)	10 (88.5)	6.9	1FT6062 - 6WF7 - ■ ■ ■ ■ ■	3	8.5 (7.52)	9.5 (20.9)
		5.1 (6.84)	16.2 (143)	16 (142)	10.3	1FT6064 - 6WF7 - ■ ■ ■ ■ ■	3	13 (11.5)	12.5 (27.6)
	80	11.0 (14.8)	35 (310)	35 (310)	27	1FT6084 - 8WF7 - ■ ■ ■ ■ ■	4	48 (42.5)	21 (46.3)
		14.5 (19.4)	47 (416)	46 (407)	37	1FT6086 - 8WF7 - ■ ■ ■ ■ ■	4	66.5 (58.9)	26 (57.3)
	100	24.5 (32.9)	85 (752)	78 (690)	82	1FT6105 - 8WF7 - ■ ■ ■ ■ ■	4	168 (149)	45.5 (100)
		34.2 (45.9)	119 (1053)	109 (965)	81	1FT6108 - 8WF7 - ■ ■ ■ ■ ■	4	260 (230)	61.5 (136)
4500	63	4.7 (6.30)	10.2 (90.3)	10 (88.5)	9.6	1FT6062 - 6WH7 - ■ ■ ■ ■ ■	3	8.5 (7.52)	9.5 (20.9)
		7.5 (10.1)	16.2 (143)	16 (142)	15.2	1FT6064 - 6WH7 - ■ ■ ■ ■ ■	3	13 (11.5)	12.5 (27.6)
	80	16.5 (22.1)	35 (310)	35 (310)	39	1FT6084 - 8WH7 - ■ ■ ■ ■ ■	4	48 (42.5)	21 (46.3)
		21.2 (28.4)	47 (416)	45 (398)	53	1FT6086 - 8WH7 - ■ ■ ■ ■ ■	4	66.5 (58.9)	26 (57.3)
6000	63	6.2 (8.31)	10.2 (90.3)	9.8 (86.7)	12.7	1FT6062 - 6WK7 - ■ ■ ■ ■ ■	3	8.5 (7.52)	9.5 (20.9)
		9.9 (13.3)	16.2 (143)	15.8 (140)	20	1FT6064 - 6WK7 - ■ ■ ■ ■ ■	3	13 (11.5)	12.5 (27.6)
	80	21.4 (28.7)	35 (310)	34 (301)	51	1FT6084 - 8WK7 - ■ ■ ■ ■ ■	4	48 (42.5)	21 (46.3)
		27.7 (37.1)	47 (416)	44 (389)	58	1FT6086 - 8WK7 - ■ ■ ■ ■ ■	4	66.5 (58.9)	26 (57.3)

Type:	IM B5 IM B14 ³⁾	1 2		
Connector outlet direction:	Transverse right (not for 1FT606) Transverse left (not for 1FT606) Axial NDE (not for 1FT6 with DRIVE-CLiQ and power connector size 3) Axial DE (1FT6062 only with water connection on side or below) ²⁾	1 2 3 4		
Terminal box/ cable entry: (only for 1FT61)	Transverse/from right Transverse/from left Axial/from NDE Axial/from DE	5 6 7 8		
Encoder systems for motors without DRIVE-CLiQ interface:	Incremental encoder sin/cos 1 V _{pp} 2048 S/R Absolute encoder EnDat 2048 S/R Multi-pole resolver 2-pole resolver		A E S T	
Encoder systems for motors with DRIVE-CLiQ interface:	Incremental encoder 22 bit Absolute encoder, 22 bit single-turn + 12 bit multi-turn 15 bit resolver 14 bit resolver		D F U P	
Shaft extension: Fitted key and keyway Fitted key and keyway Fitted key and keyway Fitted key and keyway Plain shaft Plain shaft Plain shaft Plain shaft	Shaft and flange accuracy: Tolerance N Tolerance N Tolerance R Tolerance R Tolerance N Tolerance N Tolerance R Tolerance R		A B D E G H K L	
	Holding brake: without with without with without with without with			
Vibration magnitude: Grade A Grade A Grade A Grade A Grade R Grade R Grade R Grade R	Degree of protection: IP64 IP65 IP67 IP68 IP64 IP65 IP67 IP68			0 1 2 6 3 4 5 7

To select the degree of protection and type, see Selection guides.

Synchronous motors

Feed motors for SINAMICS S120

1FT6 standard type motors
Water cooling

Selection and Ordering Data

Motor type (continued)	Static current I_0 at M_0 $\Delta T = 100$ K A	Calculated power P_{calc} ⁷⁾ P_{calc} for M_0 $\Delta T = 100$ K kW (HP)	SINAMICS S120 Motor Module		Power cable with complete shield		
			Rated output current ⁶⁾ I_{rated} A	Booksized format Order No.	Motor connection (and brake connection) via power connector		
					Power connector Size	Motor cable cross- section ⁵⁾ mm ²	Order No. Pre-assembled cable
1FT6108-8WB7...	43	18.7 (25.1)	45	6SL312 - 1TE24 - 5AA3	3	4 x 10	6FX 002 - 5S14 -
1FT6105-8WC7...	58	17.8 (23.9)	60	6SL312 - 1TE26 - 0AA3	3	4 x 16	6FX 002 - 5S23 -
1FT6108-8WC7...	57	24.9 (33.4)	60	6SL312 - 1TE26 - 0AA3	3	4 x 16	6FX 002 - 5S23 -
1FT6062-6WF7...	6.9	3.2 (4.29)	9	6SL312 - 1TE21 - 0AA3	1	4 x 1.5	6FX 002 - 5S01 -
1FT6064-6WF7...	10.3	5.1 (6.84)	18	6SL312 - 1TE21 - 8AA3	1	4 x 1.5	6FX 002 - 5S01 -
1FT6084-8WF7...	24.5	11.0 (14.8)	30	6SL312 - 1TE23 - 0AA3	1.5	4 x 4	6FX 002 - 5S41 -
1FT6086-8WF7...	34	14.8 (19.8)	45	6SL312 - 1TE24 - 5AA3	1.5	4 x 10	6FX 002 - 5S64 -
1FT6105-8WF7...	83	26.7 (35.8)	85	6SL312 - 1TE28 - 5AA3	3	4 x 25	6FX5 002 - 5DS33 -
1FT6108-8WF7...	86	37.4 (50.2)	85 ⁴⁾	6SL312 - 1TE28 - 5AA3	3	4 x 35	6FX5 002 - 5DS43 -
1FT6062-6WH7...	9.7	4.8 (6.44)	18	6SL312 - 1TE21 - 8AA3	1	4 x 1.5	6FX 002 - 5S01 -
1FT6064-6WH7...	15.4	7.6 (10.2)	18	6SL312 - 1TE21 - 8AA3	1	4 x 2.5	6FX 002 - 5S11 -
1FT6084-8WH7...	37	16.5 (22.1)	45	6SL312 - 1TE24 - 5AA3	1.5	4 x 10	6FX 002 - 5S64 -
1FT6086-8WH7...	52	22.1 (29.6)	60	6SL312 - 1TE26 - 0AA3	3	4 x 16	6FX 002 - 5S23 -
1FT6062-6WK7...	12.9	6.4 (8.58)	18	6SL312 - 1TE21 - 8AA3	1	4 x 1.5	6FX 002 - 5S01 -
1FT6064-6WK7...	20.5	10.2 (13.7)	30	6SL312 - 1TE23 - 0AA3	1	4 x 2.5	6FX 002 - 5S11 -
1FT6084-8WK7...	47	22.0 (29.5)	60	6SL312 - 1TE26 - 0AA3	3	4 x 10	6FX 002 - 5S14 -
1FT6086-8WK7...	59	29.5 (39.6)	60	6SL312 - 1TE26 - 0AA3	3	4 x 16	6FX 002 - 5S23 -

Cooling: Internal air cooling External air cooling	0 1
Motor Module: Single Motor Module Double Motor Module	1 2
Type of power cable: MOTION-CONNECT 800 MOTION-CONNECT 500	8 5
Without brake cores With brake cores	C D
For length code as well as power and signal cables, see Connection system MOTION-CONNECT.

Notes on water cooling:

- Inlet temperature of cooling water: 30 °C (86 °F) max.
- Cooling water throughput: At least 5 l/min (5 l = 1.1 British gallons/1.32 US gallons)
- Pressure at motor inlet: $p_{max} = 3$ bar
- Cooling water connection: G 3/8"
- Coolant: Water with up to 25% corrosion protection (recommendation: Tyfocor)
- Loss of pressure between inlet and outlet < 0.1 bar

¹⁾ Delivered as standard with water connection on top.

²⁾ Water connection on right side: Add **-Z** + order code **Q20** to order number
Water connection on left side: Add **-Z** + order code **Q21** to order number
Water connection at bottom: Add **-Z** + order code **Q22** to order number.

³⁾ Same flange as for IM B5 type, but with metric threaded insert in the four fixing holes.

⁴⁾ With the specified Motor Module, the motor cannot be fully utilized with M_0 at $\Delta T = 100$ K winding temperature rise. If a Motor Module with a higher rating is used, you must check whether the specified power cable can be connected to it.

⁵⁾ The current carrying capacity of the power cables complies with IEC 60204-1 for installation type C under continuous operating conditions at an ambient air temperature of 40 °C (104 °F), designed for I_0 (100 K), PVC/PUR-insulated cable.

⁶⁾ With default setting of the pulse frequency.

⁷⁾ $P_{calc} [kW] = \frac{M_0 [Nm] \times n_{rated}}{9550}$ $P_{calc} [HP] = \frac{M_0 [lb_f-in] \times n_{rated}}{63000}$

Synchronous motors

Feed motors for SINAMICS S120

1FT6 standard type motors

Water cooling

Selection and Ordering Data

Rated speed	Shaft height	Rated power	Static torque	Rated torque	Rated current	1FT6 synchronous motors Water cooling	Number of pole pairs	Rotor moment of inertia (without brake)	Weight (without brake)
n_{rated}	SH	P_{rated} at $\Delta T=100\text{ K}$	M_0 at $\Delta T=100\text{ K}$	M_{rated} at $\Delta T=100\text{ K}$	I_{rated} at $\Delta T=100\text{ K}$	Order No. Standard type		J	m
rpm		kW (HP)	Nm (lb _f -in)	Nm (lb _f -in)	A			10^{-4} kgm^2 (10^{-3} x lb _f -in-s ²)	kg (lb)
1500	132	23.6 (31.6)	155 (1372)	150 (1328)	58	1FT6132 - 6WB76 - ■ ■ ■ ■	3	430 (381)	90 (198)
		29.1 (39.0)	200 (1770)	185 (1637)	67	1FT6134 - 6WB76 - ■ ■ ■ ■	3	547 (484)	103 (227)
		36.1 (48.4)	240 (2124)	230 (2036)	90	1FT6136 - 6WB76 - ■ ■ ■ ■	3	665 (589)	120 (265)
		45.5 (61.0)	300 (2655)	290 (2567)	112	1FT6138 - 6WB76 - ■ ■ ■ ■	3	845 (748)	137 (302)
2500	132	35.3 (47.3)	155 (1372)	135 (1195)	82	1FT6132 - 6WD76 - ■ ■ ■ ■	3	430 (381)	90 (198)
		48.4 (64.9)	200 (1770)	185 (1637)	115	1FT6134 - 6WD76 - ■ ■ ■ ■	3	547 (484)	103 (227)
		57.6 (77.2)	240 (2124)	220 (2036)	149	1FT6136 - 6WD76 - ■ ■ ■ ■	3	665 (589)	120 (265)
		72.0 (96.6)	300 (2655)	275 (2434)	162	1FT6138 - 6WD76 - ■ ■ ■ ■	3	845 (748)	137 (302)

Type: IM B35 6

**Terminal box/
Cable entry:** Transverse/from right 5
Transverse/from left 6
Axial/from NDE 7
Axial/from DE 8

**Encoder systems for motors
without DRIVE-CLiQ interface:** Incremental encoder sin/cos 1 V_{pp} 2048 S/R A
Absolute encoder EnDat 2048 S/R E
Multi-pole resolver S
2-pole resolver T

**Encoder systems for motors
with DRIVE-CLiQ interface:** Incremental encoder 22 bit D
Absolute encoder, 22 bit single-turn + 12 bit multi-turn F
15 bit resolver U
14 bit resolver P

Shaft extension:	Shaft and flange accuracy:	Holding brake:	
Fitted key and keyway	Tolerance N	without	A D G K
Fitted key and keyway	Tolerance R	without	
Plain shaft	Tolerance N	without	
Plain shaft	Tolerance R	without	

Vibration magnitude:	Degree of protection:	
Grade A	IP64	1 2 3 4
Grade A	IP65	
Grade R	IP64	
Grade R	IP65	

To select the degree of protection and type, see Selection guides.

Synchronous motors

Feed motors for SINAMICS S120

1FT6 standard type motors
Water cooling

Selection and Ordering Data

Motor type (continued)	Static current I_0 at M_0 $\Delta T=100$ K A	Calculated power $P_{calc}^4)$ P_{calc} for M_0 $\Delta T=100$ K kW (HP)	SINAMICS S120 Motor Module		Power cable with complete shield		
			Rated output current ³⁾ I_{rated} A	Booksized format Order No.	Motor connection (and brake connection) via power connector		Order No. Power cable By the meter
					Cable entry Terminal box ²⁾	Connect- able cable cross- section, max. mm ²	
1FT6132-6WB7 ...	58	24.3 (32.6)	60 ¹⁾	6SL312 - 1TE 26 - 0AA3	2 x M32 x 1.5	2 x 4 x 16	6FX 008 - 1BB61 -
1FT6134-6WB7 ...	73	31.4 (42.1)	85	6SL312 - 1TE 28 - 5AA3	2 x M40 x 1.5	2 x 4 x 35	6FX 008 - 1BB35 -
1FT6136-6WB7 ...	92	37.7 (50.6)	132	6SL312 - 1TE 31 - 3AA3	2 x M50 x 1.5	2 x 4 x 50	6FX 008 - 1BB50 -
1FT6138-6WB7 ...	112	47.1 (63.2)	132	6SL312 - 1TE 31 - 3AA3	2 x M50 x 1.5	2 x 4 x 50	6FX 008 - 1BB50 -
1FT6132-6WD7 ...	92	40.6 (54.4)	85 ¹⁾	6SL312 - 1TE 28 - 5AA3	2 x M40 x 1.5	2 x 4 x 35	6FX 008 - 1BB35 -
1FT6134-6WD7 ...	122	52.4 (70.3)	132	6SL312 - 1TE 31 - 3AA3	2 x M50 x 1.5	2 x 4 x 50	6FX 008 - 1BB50 -
1FT6136-6WD7 ...	158	62.8 (84.2)	200	6SL312 - 1TE 32 - 0AA3	2 x M50 x 1.5	2 x 4 x 50	6FX 008 - 1BB50 -
1FT6138-6WD7 ...	167	78.5 (105)	200	6SL312 - 1TE 32 - 0AA3	2 x M50 x 1.5	2 x 4 x 50	6FX 008 - 1BB50 -
Cooling:							
Internal air cooling				0			
External air cooling				1			
Motor Module:							
Single Motor Module				1			
Type of power cable:							
MOTION-CONNECT 800							8
MOTION-CONNECT 500							5
For length code as well as power and signal cables, see Connection system MOTION-CONNECT.						

Notes on water cooling

- Inlet temperature of cooling water: 30 °C (86 °F) max.
- Cooling water throughput: At least 8 l/min
(8 l = 1.76 British gallons/2.11 US gallons)
- Pressure at motor inlet: $p_{max} = 6$ bar
- Cooling water connection: G 3/8"
- Coolant: Water with up to 25% corrosion protection
(recommendation: Tyfocor)
- Loss of pressure between inlet and outlet < 0.1 bar

¹⁾ With the specified Motor Module, the motor can only be utilized for a short time after M_0 .

²⁾ Terminal box type: gk 630

³⁾ With default setting of the pulse frequency.

⁴⁾ $P_{calc} [kW] = \frac{M_0 [Nm] \times \eta_{rated}}{9550}$ $P_{calc} [HP] = \frac{M_0 [lb_f-in] \times \eta_{rated}}{63000}$

Synchronous motors

Feed motors for SINAMICS S120

1FT7 Compact motors

Overview



The new 1FT7 Compact motors are permanent-magnet-excited synchronous motors with very compact dimensions and an optically attractive design. Due to the well proven cross-profile, quick and easy mounting of the motors is possible.

The 1FT7 Compact motors fulfill the highest demands on dynamic performance, speed setting range including field weakening, shaft and flange accuracy. They are equipped with state-of-the-art encoder technology and optimized for operation on our fully digital drive and control systems.

Benefits

- High shaft and flange accuracy
- Low torque ripple (average value <math>< 1\%</math>)
- High dynamic performance
- High overload capability (up to $4 \times M_0$)
- Compact design
- High degree of protection
- Rugged, vibration-isolated encoder mounting
- Easy encoder replacement on site without alignment
- Quick and easy mounting due to cross-profile
- Rotatable connectors
- New flange type with recessed flange surface, especially suitable for toothed-belt output and vertical assembly (IM V1). The previous flange design, compatible with the 1FT6 motors, can be ordered as an option.

Application

- High-performance machine tools
- Machines with stringent requirements in terms of dynamic response and precision, such as packaging machines, foil extractor machines, printing machines and handling equipment

Synchronous motors

Feed motors for SINAMICS S120

1FT7 Compact motors

Technical specifications

Product name	1FT7 Compact motor
Type of motor	Permanent-magnet-excited synchronous motor
Magnet material	Rare-earth magnet material
Cooling	Natural cooling
Temperature monitoring	KTY 84 temperature sensor in the stator winding
Insulation of the stator winding in accordance with EN 60034-1 (IEC 60034-1)	Temperature class 155 (F) for a winding temperature of $\Delta T = 100$ K at an ambient temperature of 40 °C (104 °F)
Type in accordance with EN 60034-7 (IEC 60034-7)	IM B5 (IM V1, IM V3) with flange 0
Degree of protection in accordance with EN 60034-5 (IEC 60034-5)	IP65
Shaft extension on the drive end in accordance with DIN 748-3 (IEC 60072-1)	Plain shaft
Shaft and flange accuracy in accordance with DIN 42955 (IEC 60072-1)¹⁾	Tolerance N
Vibration magnitude in accordance with EN 60034-14 (IEC 60034-14)	Grade A is observed up to rated speed
Sound pressure level in accordance with EN ISO 1680, max.	
• 1FK703:	60 dB (A)
• 1FT704 ... 1FT706:	65 dB (A)
• 1FT708 ... 1FT710:	70 dB (A)
Encoder systems, built-in, for motors without DRIVE-CLiQ interface	<ul style="list-style-type: none"> • Incremental encoder sin/cos 1 V_{pp} 2048 S/R • Absolute encoder, multi-turn, 2048 S/R (traversing range 4096 revolutions) with EnDat interface
Encoder systems, built-in, for motors with DRIVE-CLiQ interface	<ul style="list-style-type: none"> • Incremental encoder 22 bit (2048 S/R internal) • Absolute encoder 22 bit single-turn (2048 S/R internal) + 12 bit multi-turn (traversing range 4096 revolutions)
Connection	Connectors for signals and power can be rotated up to 270°
Paint finish	Pearl dark grey (RAL 9023)
2nd rating plate	Enclosed separately
Options	<ul style="list-style-type: none"> • Type IM B5 (IM V1, IM V3) with flange 1 (compatible with 1FT6) • Shaft extension on the drive end with fitted key and keyway (half-key balancing) • Built-in holding brake • Degree of protection IP64, IP67 • Shaft and flange accuracy Tolerance R

S/R = signals/revolution

¹⁾ Shaft extension run-out, concentricity of spigot and shaft and perpendicularity of mounting face of flange to shaft.

Synchronous motors

Feed motors for SINAMICS S120

1FT7 Compact core type motors Natural cooling

Selection and Ordering Data

Rated speed	Shaft height	Rated power	Static torque	Rated torque	Rated current	1FT7 Compact synchronous motors Natural cooling	Number of pole pairs	Rotor moment of inertia (without brake)	Weight (without brake)
n_{rated}	SH	P_{rated} at $\Delta T=100\text{ K}$	M_0 at $\Delta T=100\text{ K}$	M_{rated} at $\Delta T=100\text{ K}$	I_{rated} at $\Delta T=100\text{ K}$	Order No. Core type		J	m
rpm		kW (HP)	Nm (lb _f -in)	Nm (lb _f -in)	A			10^{-4} kgm^2 ($10^{-3}\text{ x lb}_f\text{-in-s}^2$)	kg (lb)
2000	100	5.03 (6.75)	30 (266)	24 (212)	10	1FT7102 - 1AC7 ■ - 1 ■ ■ 1	5	91.4 (80.9)	26.1 (57.6)
		7.96 (10.7)	50 (443)	38 (336)	15	1FT7105 - 1AC7 ■ - 1 ■ ■ 1	5	178 (158)	44.2 (97.5)
3000	48	1.35 (1.81)	5 (44.3)	4.3 (38.1)	2.6	1FT7044 - 1AF7 ■ - 1 ■ ■ 1	3	5.43 (4.81)	7.2 (15.9)
	63	1.7 (2.28)	6 (53.1)	5.4 (47.8)	3.9	1FT7062 - 1AF7 ■ - 1 ■ ■ 1	5	7.36 (6.51)	7.1 (15.7)
		2.39 (3.20)	9 (79.7)	7.6 (67.3)	5.1	1FT7064 - 1AF7 ■ - 1 ■ ■ 1	5	11.9 (10.5)	9.7 (21.4)
	80	3.24 (4.34)	13 (115)	10.5 (92.9)	6.6	1FT7082 - 1AF7 ■ - 1 ■ ■ 1	5	26.5 (23.5)	14 (30.9)
		4.55 (6.10)	20 (177)	14.5 (128)	8.5	1FT7084 - 1AF7 ■ - 1 ■ ■ 1	5	45.1 (39.9)	20.8 (45.9)
		5.65 (7.58)	28 (248)	18 (159)	11	1FT7086 - 1AF7 ■ - 1 ■ ■ 1	5	63.6 (56.3)	31.6 (69.7)
4500	80	4.82 (6.46) ³⁾	20 (177)	11.5 (102) ³⁾	10.1 ³⁾	1FT7084 - 1AH7 ■ - 1 ■ ■ 1	5	45.1 (39.9)	20.8 (45.9)
6000	36	0.88 (1.18)	2 (17.7)	1.4 (12.4)	2.5	1FT7034 - 1AK7 ■ - 1 ■ ■ 1	3	0.85 (0.75)	3.8 (8.38)
	63	2.13 (2.86) ¹⁾	6 (53.1)	3.7 (32.7) ¹⁾	5.9 ¹⁾	1FT7062 - 1AK7 ■ - 1 ■ ■ 1	5	7.36 (6.51)	7.1 (15.7)
		2.59 (3.47) ²⁾	9 (79.7)	5.5 (48.7) ²⁾	6.1 ²⁾	1FT7064 - 1AK7 ■ - 1 ■ ■ 1	5	11.9 (10.5)	9.7 (21.4)

Type IM B5:	Flange 0 Flange 1 (compatible with 1FT6)	0 1	
Encoder systems for motors without DRIVE-CLiQ interface:	Incremental encoder sin/cos 1 V _{pp} 2048 S/R Absolute encoder EnDat 2048 S/R		N M
Encoder systems for motors with DRIVE-CLiQ interface:	Absolute encoder 22 bit Absolute encoder, 22 bit single-turn + 12 bit multi-turn		D F
Shaft extension: Plain shaft Plain shaft	Shaft and flange accuracy: Tolerance N Tolerance N	Holding brake: without with	G H
Vibration magnitude: Grade A	Degree of protection: IP65		1

To select the degree of protection and type, see Selection guides.

Synchronous motors

Feed motors for SINAMICS S120

1FT7 Compact core type motors
Natural cooling

Selection and Ordering Data

Motor type (continued)	Static current I_0 at M_0 $\Delta T=100$ K A	Calculated power P_{calc} ⁶⁾ P_{calc} for M_0 $\Delta T=100$ K kW (HP)	SINAMICS S120 Motor Module		Power cable with complete shield Motor connection (and brake connection) via power connector		
			Rated output current ⁵⁾ I_{rated} A	Booksized format Order No.	Power connector Size	Motor cable cross-section ⁴⁾ mm ²	Order No. Pre-assembled cable
1FT7102-1AC7...	12	6.28 (8.42)	18	6SL312 - TE21 - 8AA3	1.5	4 x 1.5	6FX 002 - 5 S21 -
1FT7105-1AC7...	18	10.47 (14.0)	18	6SL312 - TE21 - 8AA3	1.5	4 x 2.5	6FX 002 - 5 S31 -
1FT7044-1AF7...	2.8	1.57 (2.11)	3	6SL312 - TE13 - 0AA3	1	4 x 1.5	6FX 002 - 5 S01 -
1FT7062-1AF7...	3.9	1.88 (2.52)	5	6SL312 - TE15 - 0AA3	1	4 x 1.5	6FX 002 - 5 S01 -
1FT7064-1AF7...	5.6	2.83 (3.80)	9	6SL312 - TE21 - 0AA3	1	4 x 1.5	6FX 002 - 5 S01 -
1FT7082-1AF7...	7.6	4.08 (5.47)	9	6SL312 - TE21 - 0AA3	1	4 x 1.5	6FX 002 - 5 S01 -
1FT7084-1AF7...	11	6.28 (8.42)	18	6SL312 - TE21 - 8AA3	1	4 x 1.5	6FX 002 - 5 S01 -
1FT7086-1AF7...	15.5	8.8 (11.8)	18	6SL312 - TE21 - 8AA3	1.5	4 x 2.5	6FX 002 - 5 S31 -
1FT7084-1AH7...	15.6	9.42 (12.6)	18	6SL312 - TE21 - 8AA3	1.5	4 x 2.5	6FX 002 - 5 S31 -
1FT7034-1AK7...	2.9	1.26 (1.69)	3	6SL312 - TE13 - 0AA3	1	4 x 1.5	6FX 002 - 5 S01 -
1FT7062-1AK7...	8.4	3.77 (5.06)	9	6SL312 - TE21 - 0AA3	1	4 x 1.5	6FX 002 - 5 S01 -
1FT7064-1AK7...	9	5.65 (7.58)	9	6SL312 - TE21 - 0AA3	1	4 x 1.5	6FX 002 - 5 S01 -

Cooling:	
Internal air cooling	0
External air cooling	1
Motor Module:	
Single Motor Module	1
Double Motor Module	2
Type of power cable:	
MOTION-CONNECT 800	8
MOTION-CONNECT 500	5
Without brake cores	C
With brake cores	D
For length code as well as power and signal cables, see Connection system MOTION-CONNECT.

6

1) These values refer to $n = 5500$ rpm.

2) These values refer to $n = 4500$ rpm.

3) These values refer to $n = 4000$ rpm.

4) The current carrying capacity of the power cables complies with IEC 60204-1 for installation type C under continuous operating conditions at an ambient air temperature of 40 °C (104 °F), designed for I_0 (100 K), PVC/PUR-insulated cable.

5) With default setting of the pulse frequency.

6) $P_{calc} [kW] = \frac{M_0 [Nm] \times n_{rated}}{9550}$ $P_{calc} [HP] = \frac{M_0 [lb_f \cdot in] \times n_{rated}}{63000}$

Synchronous motors

Feed motors for SINAMICS S120

1FT7 Compact standard type motors

Natural cooling

Selection and Ordering Data

Rated speed	Shaft height	Rated power	Static torque	Rated torque	Rated current	1FT7 Compact synchronous motors Natural cooling	Number of pole pairs	Rotor moment of inertia (without brake)	Weight (without brake)
n_{rated}	SH	P_{rated} at $\Delta T=100\text{ K}$	M_0 at $\Delta T=100\text{ K}$	M_{rated} at $\Delta T=100\text{ K}$	I_{rated} at $\Delta T=100\text{ K}$	Order No. Standard type		J	m
rpm		kW (HP)	Nm (lb _f -in)	Nm (lb _f -in)	A			10^{-4} kgm^2 ($10^{-3}\text{ x lb}_f\text{-in-s}^2$)	kg (lb)
1500	100	4.08 (5.47)	30 (266)	26 (230)	8	1FT7102 - 5AB7 ■ - 1 ■ ■ ■ ■	5	91.4 (80.9)	26.1 (57.6)
		6.6 (8.85)	50 (443)	42 (372)	13	1FT7105 - 5AB7 ■ - 1 ■ ■ ■ ■	5	178 (158)	44.2 (97.5)
		9.58 (12.8)	70 (620)	61 (540)	16	1FT7108 - 5AB7 ■ - 1 ■ ■ ■ ■	5	248 (220)	59 (130)
Type IM B5:			Flange 0 Flange 1 (compatible with 1FT6)		0 1				
Encoder systems for motors without DRIVE-CLiQ interface:			Incremental encoder sin/cos 1 V _{pp} 2048 S/R Absolute encoder EnDat 2048 S/R			N M			
Encoder systems for motors with DRIVE-CLiQ interface:			Incremental encoder 22 bit Absolute encoder, 22 bit single-turn + 12 bit multi-turn			D F			
Shaft extension:		Shaft and flange accuracy:		Holding brake:			A B D E G H K L		
Fitted key and keyway		Tolerance N		without					
Fitted key and keyway		Tolerance N		with					
Fitted key and keyway		Tolerance R		without					
Fitted key and keyway		Tolerance R		with					
Plain shaft		Tolerance N		without					
Plain shaft		Tolerance N		with					
Plain shaft		Tolerance R		without					
Plain shaft		Tolerance R		with					
Vibration magnitude:			Degree of protection:				0 1 2		
Grade A			IP64						
Grade A			IP65						
Grade A			IP67						

To select the degree of protection and type, see Selection guides.

Synchronous motors

Feed motors for SINAMICS S120

1FT7 Compact standard type motors
Natural cooling

Selection and Ordering Data

Motor type (continued)	Static current I_0 at T_0 $\Delta T=100$ K A	Calculated power $P_{calc}^{3)}$ P_{calc} for M_0 $\Delta T=100$ K kW (HP)	SINAMICS S120 Motor Module		Power cable with complete shield Motor connection (and brake connection) via power connector		
			Rated output current ²⁾ I_{rated} A	Booksize format Order No.	Power connector Size	Motor cable cross-section ¹⁾ mm ²	Order No. Pre-assembled cable
1FT7102-5AB7...	9	4.71 (6.32)	9	6SL312 - - TE21 - 0AA3	1.5	4 x 1.5	6FX 002 - 5 S21 -
1FT7105-5AB7...	15	7.85 (10.5)	18	6SL312 - - TE21 - 8AA3	1.5	4 x 1.5	6FX 002 - 5 S21 -
1FT7108-5AB7...	18	10.99 (14.7)	18	6SL312 - - TE21 - 8AA3	1.5	4 x 2.5	6FX 002 - 5 S31 -
Cooling:							
Internal air cooling							
External air cooling							
Motor Module:							
Single Motor Module							
Double Motor Module							
Type of power cable:							
MOTION-CONNECT 800							
MOTION-CONNECT 500							
Without brake cores							
With brake cores							
For length code as well as power and signal cables, see Connection system MOTION-CONNECT.							

¹⁾ The current carrying capacity of the power cables complies with IEC 60204-1 for installation type C under continuous operating conditions at an ambient air temperature of 40 °C (104 °F), designed for I_0 (100 K), PVC/PUR-insulated cable.

²⁾ With default setting of the pulse frequency.

³⁾ $P_{calc} [kW] = \frac{M_0 [Nm] \times n_{rated}}{9550}$ $P_{calc} [HP] = \frac{M_0 [lb_f-in] \times n_{rated}}{63000}$

Synchronous motors

Feed motors for SINAMICS S120

1FT7 Compact standard type motors

Natural cooling

Selection and Ordering Data

Rated speed	Shaft height	Rated power	Static torque	Rated torque	Rated current	1FT7 Compact synchronous motors Natural cooling	Number of pole pairs	Rotor moment of inertia (without brake)	Weight (without brake)
n_{rated}	SH	P_{rated} at $\Delta T=100\text{ K}$	M_0 at $\Delta T=100\text{ K}$	M_{rated} at $\Delta T=100\text{ K}$	I_{rated} at $\Delta T=100\text{ K}$	Order No. Standard type		J	m
rpm		kW (HP)	Nm (lb _f -in)	Nm (lb _f -in)	A			10^{-4} kgm^2 ($10^{-3}\text{ x lb}_f\text{-in-s}^2$)	kg (lb)
2000	80	2.39 (3.20)	13 (115)	11.4 (101)	4.7	1FT7082 - 5AC7 ■ - 1 ■ ■ ■ ■	5	26.5 (23.5)	14 (30.9)
		3.54 (4.75)	20 (177)	16.9 (150)	7.8	1FT7084 - 5AC7 ■ - 1 ■ ■ ■ ■	5	45.1 (39.9)	20.8 (45.9)
		4.71 (6.32)	28 (248)	22.5 (199)	9.2	1FT7086 - 5AC7 ■ - 1 ■ ■ ■ ■	5	63.6 (56.3)	31.8 (70.1)
	100	5.03 (6.75)	30 (266)	24 (212)	10	1FT7102 - 5AC7 ■ - 1 ■ ■ ■ ■	5	91.4 (80.9)	26.1 (57.6)
		7.96 (10.7)	50 (443)	38 (336)	15	1FT7105 - 5AC7 ■ - 1 ■ ■ ■ ■	5	178 (158)	44.1 (97.2)
		10.5 (14.1)	70 (620)	50 (443)	18	1FT7108 - 5AC7 ■ - 1 ■ ■ ■ ■	5	248 (220)	59 (130)
Type IM B5:			Flange 0 Flange 1 (compatible with 1FT6)			0 1			
Encoder systems for motors without DRIVE-CLiQ interface:			Incremental encoder sin/cos 1 V _{pp} 2048 S/R Absolute encoder EnDat 2048 S/R				N M		
Encoder systems for motors with DRIVE-CLiQ interface:			Incremental encoder 22 bit Absolute encoder, 22 bit single-turn + 12 bit multi-turn				D F		
Shaft extension:			Shaft and flange accuracy:			Holding brake:			
Fitted key and keyway			Tolerance N			without			A B D E G H K L
Fitted key and keyway			Tolerance N			with			
Fitted key and keyway			Tolerance R			without			
Fitted key and keyway			Tolerance R			with			
Plain shaft			Tolerance N			without			
Plain shaft			Tolerance N			with			
Plain shaft			Tolerance R			without			
Plain shaft			Tolerance R			with			
Vibration magnitude:			Degree of protection:						0 1 2
Grade A			IP64						
Grade A			IP65						
Grade A			IP67						

To select the degree of protection and type, see Selection guides.

Synchronous motors

Feed motors for SINAMICS S120

1FT7 Compact standard type motors
Natural cooling

Selection and Ordering Data

Motor type (continued)	Static current I_0 at M_0 $\Delta T=100$ K A	Calculated power $P_{calc}^{3)}$ P_{calc} for M_0 $\Delta T=100$ K kW (HP)	SINAMICS S120 Motor Module		Power cable with complete shield Motor connection (and brake connection) via power connector		
			Rated output current ²⁾ I_{rated} A	Booksize format Order No.	Power connector Size	Motor cable cross- section ¹⁾ mm ²	Order No. Pre-assembled cable
1FT7082-5AC7...	4.9	2.72 (3.65)	5	6SL312 - TE15 - 0AA3	1	4 x 1.5	6FX 002 - 5 S01 -
1FT7084-5AC7...	8.5	4.19 (5.62)	9	6SL312 - TE21 - 0AA3	1	4 x 1.5	6FX 002 - 5 S01 -
1FT7086-5AC7...	10.6	5.86 (7.86)	18	6SL312 - TE21 - 8AA3	1	4 x 1.5	6FX 002 - 5 S01 -
1FT7102-5AC7...	12	6.28 (8.42)	18	6SL312 - TE21 - 8AA3	1.5	4 x 1.5	6FX 002 - 5 S21 -
1FT7105-5AC7...	18	10.47 (14.0)	18	6SL312 - TE21 - 8AA3	1.5	4 x 2.5	6FX 002 - 5 S31 -
1FT7108-5AC7...	25	14.66 (19.7)	30	6SL312 - TE23 - 1AA3	1.5	4 x 4	6FX 002 - 5 S41 -
Cooling:							
Internal air cooling							
External air cooling							
Motor Module:							
Single Motor Module							
Double Motor Module							
Type of power cable:							
MOTION-CONNECT 800							
MOTION-CONNECT 500							
Without brake cores							
With brake cores							
For length code as well as power and signal cables, see Connection system MOTION-CONNECT.							

¹⁾ The current carrying capacity of the power cables complies with IEC 60204-1 for installation type C under continuous operating conditions at an ambient air temperature of 40 °C (104 °F), designed for I_0 (100 K), PVC/PUR-insulated cable.

²⁾ With default setting of the pulse frequency.

³⁾ $P_{calc} [kW] = \frac{M_0 [Nm] \times n_{rated}}{9550}$ $P_{calc} [HP] = \frac{M_0 [lb_f-in] \times n_{rated}}{63000}$

Synchronous motors

Feed motors for SINAMICS S120

1FT7 Compact standard type motors Natural cooling

Selection and Ordering Data

Rated speed	Shaft height	Rated power	Static torque	Rated torque	Rated current	1FT7 Compact synchronous motors Natural cooling	Number of pole pairs	Rotor moment of inertia (without brake)	Weight (without brake)
n_{rated}	SH	P_{rated} at $\Delta T=100\text{ K}$	M_0 at $\Delta T=100\text{ K}$	M_{rated} at $\Delta T=100\text{ K}$	I_{rated} at $\Delta T=100\text{ K}$	Order No. Standard type		J	m
rpm		kW (HP)	Nm (lb _f -in)	Nm (lb _f -in)	A			10 ⁻⁴ kgm ² (10 ⁻³ x lb _f -in-s ²)	kg (lb)
3000	48	0.85 (1.14)	3 (26.6)	2.7 (23.9)	2.1	1FT7042 - 5AF 7 - 1 ■ ■ ■ ■	3	2.81 (2.49)	4.6 (10.1)
		1.35 (1.81)	5 (44.3)	4.3 (38.1)	2.6	1FT7044 - 5AF 7 - 1 ■ ■ ■ ■	3	5.43 (4.81)	7.2 (15.9)
		1.76 (2.36)	7 (62.0)	5.6 (49.6)	3.5	1FT7046 - 5AF 7 - 1 ■ ■ ■ ■	3	7.52 (6.66)	9.3 (20.5)
	63	1.7 (2.28)	6 (53.1)	5.4 (47.8)	3.9	1FT7062 - 5AF 7 - 1 ■ ■ ■ ■	5	7.36 (6.51)	7.1 (15.7)
		2.39 (3.20)	9 (79.7)	7.6 (67.3)	5.1	1FT7064 - 5AF 7 - 1 ■ ■ ■ ■	5	11.9 (10.5)	9.7 (21.4)
		2.92 (3.92)	12 (106)	9.3 (82.3)	7.2	1FT7066 - 5AF 7 - 1 ■ ■ ■ ■	5	16.4 (14.5)	12.3 (27.1)
		3.42 (4.59)	15 (133)	10.9 (96.5)	6.7	1FT7068 - 5AF 7 - 1 ■ ■ ■ ■	5	23.2 (20.5)	16.3 (35.9)
	80	3.24 (4.34)	13 (115)	10.5 (92.9)	6.6	1FT7082 - 5AF 7 - 1 ■ ■ ■ ■	5	26.5 (23.5)	14 (30.9)
		4.55 (6.10)	20 (177)	14.5 (128)	8.5	1FT7084 - 5AF 7 - 1 ■ ■ ■ ■	5	45.1 (39.1)	20.8 (45.9)
		5.62 (7.54)	28 (248)	18 (159)	11	1FT7086 - 5AF 7 - 1 ■ ■ ■ ■	5	63.6 (56.3)	31.8 (70.1)
	100	6.28 (8.42)	30 (266)	20 (177)	12	1FT7102 - 5AF 7 - 1 ■ ■ ■ ■	5	91.4 (80.9)	26.1 (57.6)
		8.8 (11.8)	50 (443)	28 (248)	15	1FT7105 - 5AF 7 - 1 ■ ■ ■ ■	5	178 (158)	44.2 (97.5)

Type IM B5:	Flange 0 Flange 1 (compatible with 1FT6)	0 1
Encoder systems for motors without DRIVE-CLiQ interface:	Incremental encoder sin/cos 1 V _{pp} 2048 S/R Absolute encoder EnDat 2048 S/R	N M
Encoder systems for motors with DRIVE-CLiQ interface:	Incremental encoder 22 bit Absolute encoder, 22 bit single-turn + 12 bit multi-turn	D F
Shaft extension:	Shaft and flange accuracy:	Holding brake:
Fitted key and keyway	Tolerance N	without
Fitted key and keyway	Tolerance N	with
Fitted key and keyway	Tolerance R	without
Fitted key and keyway	Tolerance R	with
Plain shaft	Tolerance N	without
Plain shaft	Tolerance N	with
Plain shaft	Tolerance R	without
Plain shaft	Tolerance R	with
		A B D E G H K L
Vibration magnitude:	Degree of protection:	0 1 2
Grade A	IP64	
Grade A	IP65	
Grade A	IP67	

To select the degree of protection and type, see Selection guides.

6

Synchronous motors

Feed motors for SINAMICS S120

1FT7 Compact standard type motors
Natural cooling

Selection and Ordering Data

Motor type (continued)	Static current I_0 at M_0 $\Delta T=100$ K A	Calculated power $P_{calc}^{(3)}$ P_{calc} for M_0 $\Delta T=100$ K kW (HP)	SINAMICS S120 Motor Module		Power cable with complete shield Motor connection (and brake connection) via power connector		
			Rated output current ⁽²⁾ I_{rated} A	Booksize format Order No.	Power connector Size	Motor cable cross-section ⁽¹⁾ mm ²	Order No. Pre-assembled cable
1FT7042-5AF7...	2.1	0.94 (1.26)	3	6SL312 - TE13 - 0AA3	1	4 x 1.5	6FX 002 - 5S01 -
1FT7044-5AF7...	2.8	1.57 (2.11)	3	6SL312 - TE13 - 0AA3	1	4 x 1.5	6FX 002 - 5S01 -
1FT7046-5AF7...	4	2.2 (2.95)	5	6SL312 - TE15 - 0AA3	1	4 x 1.5	6FX 002 - 5S01 -
1FT7062-5AF7...	3.9	1.88 (2.52)	5	6SL312 - TE15 - 0AA3	1	4 x 1.5	6FX 002 - 5S01 -
1FT7064-5AF7...	5.6	2.83 (3.80)	9	6SL312 - TE21 - 0AA3	1	4 x 1.5	6FX 002 - 5S01 -
1FT7066-5AF7...	8.4	3.77 (5.06)	9	6SL312 - TE21 - 0AA3	1	4 x 1.5	6FX 002 - 5S01 -
1FT7068-5AF7...	8.3	4.71 (6.32)	9	6SL312 - TE21 - 0AA3	1	4 x 1.5	6FX 002 - 5S01 -
1FT7082-5AF7...	7.6	4.08 (5.47)	9	6SL312 - TE21 - 0AA3	1	4 x 1.5	6FX 002 - 5S01 -
1FT7084-5AF7...	11	6.28 (8.42)	18	6SL312 - TE21 - 8AA3	1	4 x 1.5	6FX 002 - 5S01 -
1FT7086-5AF7...	15.5	8.8 (11.8)	18	6SL312 - TE21 - 8AA3	1.5	4 x 2.5	6FX 002 - 5S31 -
1FT7102-5AF7...	18	9.42 (12.6)	18	6SL312 - TE21 - 8AA3	1.5	4 x 2.5	6FX 002 - 5S31 -
1FT7105-5AF7...	26	15.71 (21.1)	30	6SL312 - TE23 - 1AA3	1.5	4 x 4	6FX 002 - 5S41 -
Cooling:							
Internal air cooling							
External air cooling							
Motor Module:							
Single Motor Module							
Double Motor Module							
Type of power cable:							
MOTION-CONNECT 800							
MOTION-CONNECT 500							
Without brake cores							
With brake cores							
For length code as well as power and signal cables, see Connection system MOTION-CONNECT.							

6

¹⁾ The current carrying capacity of the power cables complies with IEC 60204-1 for installation type C under continuous operating conditions at an ambient air temperature of 40 °C (104 °F), designed for I_0 (100 K), PVC/PUR-insulated cable.

²⁾ With default setting of the pulse frequency.

³⁾ $P_{calc} [kW] = \frac{M_0 [Nm] \times \eta_{rated}}{9550}$ $P_{calc} [HP] = \frac{M_0 [lb_f-in] \times \eta_{rated}}{63000}$

Synchronous motors

Feed motors for SINAMICS S120

1FT7 Compact standard type motors Natural cooling

Selection and Ordering Data

Rated speed	Shaft height	Rated power	Static torque	Rated torque	Rated current	1FT7 Compact synchronous motors Natural cooling	Number of pole pairs	Rotor moment of inertia (without brake)	Weight (without brake)
n_{rated}	SH	P_{rated} at $\Delta T=100\text{ K}$	M_0 at $\Delta T=100\text{ K}$	M_{rated} at $\Delta T=100\text{ K}$	I_{rated} at $\Delta T=100\text{ K}$	Order No. Standard type		J	m
rpm		kW (HP)	Nm (lb _f -in)	Nm (lb _f -in)	A			10 ⁻⁴ kgm ² (10 ⁻³ x lb _f -in-s ²)	kg (lb)
4500	48	1.32 (1.77) ¹⁾	7 (62.0)	3.6 (31.9) ¹⁾	4.7 ¹⁾	1FT7046 - 5AH7 ■ - 1 ■ ■ ■ ■	3	7.52 (6.66)	9.3 (20.5)
	63	2.55 (3.42) ²⁾	12 (106)	6.1 (54.0) ²⁾	7.5 ²⁾	1FT7066 - 5AH7 ■ - 1 ■ ■ ■ ■	5	16.4 (14.5)	12.3 (27.1)
	80	3.77 (5.06)	13 (115)	8 (70.8)	8.4	1FT7082 - 5AH7 ■ - 1 ■ ■ ■ ■	5	26.5 (23.5)	14 (30.9)
		4.82 (6.46) ²⁾	20 (177)	11.5 (102) ²⁾	10.1 ²⁾	1FT7084 - 5AH7 ■ - 1 ■ ■ ■ ■	5	45.1 (39.9)	20.8 (45.9)
Type IM B5:			Flange 0 Flange 1 (compatible with 1FT6)			0 1			
Encoder systems for motors without DRIVE-CLiQ interface:			Incremental encoder sin/cos 1 V _{pp} 2048 S/R Absolute encoder EnDat 2048 S/R				N M		
Encoder systems for motors with DRIVE-CLiQ interface:			Incremental encoder 22 bit Absolute encoder, 22 bit single-turn + 12 bit multi-turn				D F		
Shaft extension:		Shaft and flange accuracy:		Holding brake:			A B D E G H K L		
Fitted key and keyway		Tolerance N		without					
Fitted key and keyway		Tolerance N		with					
Fitted key and keyway		Tolerance R		without					
Fitted key and keyway		Tolerance R		with					
Plain shaft		Tolerance N		without					
Plain shaft		Tolerance N		with					
Plain shaft		Tolerance R		without					
Plain shaft		Tolerance R		with					
Vibration magnitude:			Degree of protection:				0 1 2		
Grade A			IP64						
Grade A			IP65						
Grade A			IP67						

To select the degree of protection and type, see Selection guides.

Synchronous motors

Feed motors for SINAMICS S120

1FT7 Compact standard type motors
Natural cooling

Selection and Ordering Data

Motor type (continued)	Static current I_0 at M_0 $\Delta T=100$ K A	Calculated power $P_{calc}^{5)}$ P_{calc} for M_0 $\Delta T=100$ K kW (HP)	SINAMICS S120 Motor Module		Power cable with complete shield Motor connection (and brake connection) via power connector		
			Rated output current ⁴⁾ I_{rated} A	Booksize format Order No.	Power connector Size	Motor cable cross-section ³⁾ mm ²	Order No. Pre-assembled cable
1FT7046-5AH7...	8.1	3.3 (4.43)	9	6SL3122 - TE21 - 0AA3	1	4 x 1.5	6FX002 - 5S01 -
1FT7066-5AH7...	13.6	5.65 (7.58)	18	6SL3122 - TE21 - 8AA3	1	4 x 1.5	6FX002 - 5S01 -
1FT7082-5AH7...	12.3	6.13 (8.22)	18	6SL3122 - TE21 - 8AA3	1	4 x 1.5	6FX002 - 5S01 -
1FT7084-5AH7...	15.6	9.42 (12.6)	18	6SL3122 - TE21 - 8AA3	1.5	4 x 2.5	6FX002 - 5S31 -
Cooling:							
Internal air cooling							
External air cooling							
Motor Module:							
Single Motor Module							
Double Motor Module							
Type of power cable:							
MOTION-CONNECT 800							
MOTION-CONNECT 500							
Without brake cores							
With brake cores							
For length code as well as power and signal cables, see Connection system MOTION-CONNECT.							

1) These values refer to $n = 3500$ rpm.

2) These values refer to $n = 4000$ rpm.

3) The current carrying capacity of the power cables complies with IEC 60204-1 for installation type C under continuous operating conditions at an ambient air temperature of 40 °C (104 °F), designed for I_0 (100 K), PVC/PUR-insulated cable.

4) With default setting of the pulse frequency.

5) $P_{calc} [kW] = \frac{M_0 [Nm] \times n_{rated}}{9550}$ $P_{calc} [HP] = \frac{M_0 [lb_f-in] \times n_{rated}}{63000}$

Synchronous motors

Feed motors for SINAMICS S120

1FT7 Compact standard type motors

Natural cooling

Selection and Ordering Data

Rated speed	Shaft height	Rated power	Static torque	Rated torque	Rated current	1FT7 Compact synchronous motors Natural cooling	Number of pole pairs	Rotor moment of inertia (without brake)	Weight (without brake)
n_{rated}	SH	P_{rated} at $\Delta T=100\text{ K}$	M_0 at $\Delta T=100\text{ K}$	M_{rated} at $\Delta T=100\text{ K}$	I_{rated} at $\Delta T=100\text{ K}$	Order No. Standard type		J	m
rpm		kW (HP)	Nm (lb _f -in)	Nm (lb _f -in)	A			10^{-4} kgm^2 ($10^{-3}\text{ x lb}_f\text{-in-s}^2$)	kg (lb)
6000	36	0.88 (1.18)	2 (17.7)	1.4 (12.4)	2.5	1FT7034 - 5AK7 ■ - 1 ■ ■ ■ ■	3	0.85 (0.75)	3.8 (8.38)
		1.07 (1.43)	3 (26.6)	1.7 (15.0)	2.6	1FT7036 - 5AK7 ■ - 1 ■ ■ ■ ■	3	1.33 (1.18)	5 (11.0)
	48	1.26 (1.69)	3 (26.6)	2 (17.7)	3	1FT7042 - 5AK7 ■ - 1 ■ ■ ■ ■	3	2.81 (2.49)	4.6 (10.1)
		1.41 (1.89) ¹⁾	5 (44.3)	3 (26.6) ¹⁾	3.6 ¹⁾	1FT7044 - 5AK7 ■ - 1 ■ ■ ■ ■	3	5.43 (4.81)	7.2 (15.9)
	60	2.13 (2.86) ²⁾	6 (53.1)	3.7 (32.7) ²⁾	5.9 ²⁾	1FT7062 - 5AK7 ■ - 1 ■ ■ ■ ■	5	7.36 (6.51)	7.1 (15.7)
		2.59 (2.59) ¹⁾	9 (79.7)	5.5 (48.7) ¹⁾	6.1 ¹⁾	1FT7064 - 5AK7 ■ - 1 ■ ■ ■ ■	5	11.9 (10.5)	9.7 (21.4)
Type IM B5:			Flange 0 Flange 1 (compatible with 1FT6)			0 1			
Encoder systems for motors without DRIVE-CLiQ interface:			Incremental encoder sin/cos 1 V _{pp} 2048 S/R Absolute encoder EnDat 2048 S/R			N M			
Encoder systems for motors with DRIVE-CLiQ interface:			Incremental encoder 22 bit Absolute encoder, 22 bit single-turn + 12 bit multi-turn			D F			
Shaft extension:		Shaft and flange accuracy:		Holding brake:					
Fitted key and keyway		Tolerance N		without					
Fitted key and keyway		Tolerance N		with					
Fitted key and keyway		Tolerance R		without					
Fitted key and keyway		Tolerance R		with					
Plain shaft		Tolerance N		without					
Plain shaft		Tolerance N		with					
Plain shaft		Tolerance R		without					
Plain shaft		Tolerance R		with					
Vibration magnitude:			Degree of protection:						
Grade A			IP64						
Grade A			IP65						
Grade A			IP67						
								0 1 2	

To select the degree of protection and type, see Selection guides.

Synchronous motors

Feed motors for SINAMICS S120

1FT7 Compact standard type motors
Natural cooling

Selection and Ordering Data

Motor type (continued)	Static current I_0 at M_0 $\Delta T=100$ K A	Calculated power $P_{calc}^{5)}$ P_{calc} for M_0 $\Delta T=100$ K kW (HP)	SINAMICS S120 Motor Module		Power cable with complete shield		
			Rated output current ⁴⁾ I_{rated} A	Booksize format Order No.	Motor connection (and brake connection) via power connector		
					Power connector Size	Motor cable cross-section ³⁾ mm ²	Order No. Pre-assembled cable
1FT7034-5AK7...	2.9	1.26 (1.69)	3	6SL312 - TE13 - 0AA3	1	4 x 1.5	6FX 002 - 5S01 -
1FT7036-5AK7...	4.3	1.88 (2.52)	5	6SL312 - TE15 - 0AA3	1	4 x 1.5	6FX 002 - 5S01 -
1FT7042-5AK7...	3.9	1.89 (2.53)	5	6SL312 - TE15 - 0AA3	1	4 x 1.5	6FX 002 - 5S01 -
1FT7044-5AK7...	5.7	3.15 (4.22)	9	6SL312 - TE21 - 0AA3	1	4 x 1.5	6FX 002 - 5S01 -
1FT7062-5AK7...	8.4	3.78 (5.07)	9	6SL312 - TE21 - 0AA3	1	4 x 1.5	6FX 002 - 5S01 -
1FT7064-5AK7...	9	5.67 (7.60)	9	6SL312 - TE21 - 0AA3	1	4 x 1.5	6FX 002 - 5S01 -
Cooling:							
Internal air cooling					0		
External air cooling					1		
Motor Module:							
Single Motor Module					1		
Double Motor Module					2		
Type of power cable:							
MOTION-CONNECT 800						8	
MOTION-CONNECT 500						5	
Without brake cores							C
With brake cores							D
For length code as well as power and signal cables, see Connection system MOTION-CONNECT.						

6

1) These values refer to $n = 4500$ rpm.

2) These values refer to $n = 5500$ rpm.

3) The current carrying capacity of the power cables complies with IEC 60204-1 for installation type C under continuous operating conditions at an ambient air temperature of 40 °C (104 °F), designed for I_0 (100 K), PVC/PUR-insulated cable.

4) With default setting of the pulse frequency.

5) $P_{calc} [kW] = \frac{M_0 [Nm] \times n_{rated}}{9550}$ $P_{calc} [HP] = \frac{M_0 [lb_f-in] \times n_{rated}}{63000}$

Synchronous motors

Feed motors for SINAMICS S120

1FK7 motors

Overview



1FK7 motors are extremely compact, permanent-magnet-excited synchronous motors. The available options, gearboxes and encoders, together with the expanded product range, mean that 1FK7 motors can be optimally adapted to any application. They therefore also satisfy the permanently increasing demands of state-of-the-art machine generations.

1FK7 motors can be combined with the SINAMICS S120 drive system to create a powerful system with high functionality. The integrated encoder systems for speed and position control can be selected depending on the application.

The motors are designed for operation without external cooling and the heat is dissipated through the motor surface. 1FK7 motors have a high overload capability.

Benefits

1FK7 Compact motors offer:

- Space-saving installation thanks to extremely high power density
- Can be used universally for many applications
- Wide range of motors

1FK7 High Dynamic motors offer:

- Extremely high dynamic response due to low rotor moment of inertia

Application

- Machine tools
- Robots and handling systems
- Wood, glass, ceramics and stone working
- Packaging, plastics and textile machines
- Auxiliary axes

Synchronous motors

Feed motors for SINAMICS S120

1FK7 motors

Technical specifications

Product name	1FK7 Compact motor 1FK7 High Dynamic motor
Type of motor	Permanent-magnet-excited synchronous motor
Magnet material	Rare-earth magnet material
Cooling	Natural cooling
Temperature monitoring	KTY 84 temperature sensor in stator winding
Insulation of the stator winding in accordance with EN 60034-1 (IEC 60034-1)	Temperature class 155 (F) for a winding temperature rise of $\Delta T = 100$ K at an ambient temperature of 40 °C (104 °F)
Type in accordance with EN 60034-7 (IEC 60034-7)	IM B5 (IM V1, IM V3)
Degree of protection in accordance with EN 60034-5 (IEC 60034-5)	IP64
Shaft extension on the drive end in accordance with DIN 748-3 (IEC 60072-1)	Plain shaft
Shaft and flange accuracy in accordance with DIN 42955 (IEC 60072-1)¹⁾	Tolerance N
Vibration magnitude in accordance with EN 60034-14 (IEC 60034-14)	Grade A is observed up to rated speed
Sound pressure level in accordance with EN ISO 1680, max.	
• 1FK701 ... 1FK704:	55 dB (A)
• 1FK706:	65 dB (A)
• 1FK708 ... 1FK710:	70 dB (A)
Encoder systems, built-in for motors without DRIVE-CLiQ interface	<ul style="list-style-type: none"> • Incremental encoder sin/cos 1 V_{pp} 2048 S/R • Absolute encoder, multi-turn (traversing range 4096 revolutions) with EnDat interface 1FK704 ... 1FK710: 2048 S/R 1FK701 ... 1FK703: 512 S/R 1FK704 ... 1FK710: 32 S/R 1FK701 ... 1FK703: 16 S/R • Multi-pole resolver (number of poles corresponds to number of pole pairs of the motor) • 2-pole resolver

Encoder systems, built-in for motors with DRIVE-CLiQ interface

- Incremental encoder 22 bit (2048 S/R internal)
- Absolute encoder single-turn + 12 bit multi-turn (traversing range 4096 revolutions)
1FK704 ... 1FK710: 22 bit single-turn (2048 S/R internal)
1FK701 ... 1FK703: 20 bit single-turn (512 S/R internal)
1FK704 ... 1FK710: 16 bit single-turn (32 S/R internal)
1FK701 ... 1FK703: 15 bit single-turn (16 S/R internal)
- 15 bit resolver
- 14 bit resolver

Connection	Connectors for signals and power can be rotated (270°)
Paint finish	Unpainted
2nd rating plate	Attached in the NDE cover
3rd rating plate	Enclosed separately
Options²⁾	<ul style="list-style-type: none"> • Shaft extension on the drive end with fitted key and keyway (half-key balancing) • Built-in holding brake • Degree of protection IP65, plus DE flange IP67 • Planetary gearbox, built-on (requires: plain shaft extension, degree of protection IP64 for LP+ and IP65 for SP+) • Anthracite paint finish

S/R = signals/revolution

¹⁾ Shaft extension run-out, concentricity of spigot and shaft and perpendicularity of mounting face of flange to shaft.

²⁾ 1FK701 only available in degree of protection IP54 and anthracite paint finish, separately packed rating plate, planetary gearbox not available.

Synchronous motors

Feed motors for SINAMICS S120

1FK7 Compact motors Natural cooling

Selection and Ordering Data

Rated speed	Shaft height	Rated power	Static torque	Rated torque ¹⁾	Rated current	1FK7 Compact synchronous motor Natural cooling	Number of pole pairs	Rotor moment of inertia (without brake)	Weight (without brake)
n_{rated}	SH	P_{rated} at $\Delta T=100\text{ K}$	M_0 at $\Delta T=100\text{ K}$	M_{rated} at $\Delta T=100\text{ K}$	I_{rated} at $\Delta T=100\text{ K}$	Order No.		J	m
rpm		kW (HP)	Nm (lb _f -in)	Nm (lb _f -in)	A			10 ⁻⁴ kgm ² (10 ⁻³ x lb _f -in-s ²)	kg (lb)
2000	100	7.75 (10.4)	48 (425)	37 (327)	16	1FK7105 - 5AF71- 1 ■ ■ ■ ■	4	156 (138)	39 (86.0)
3000	48	0.82 (1.10)	3 (26.6)	2.6 (23.0)	1.95	1FK7042 - 5AF71- 1 ■ ■ ■ ■	4	3.01(2.66)	4.9 (10.8)
	63	1.48 (1.98)	6 (53.1)	4.7 (41.6)	3.7	1FK7060 - 5AF71- 1 ■ ■ ■ ■	4	7.95(7.04)	7 (15.4)
		2.29 (3.07)	11 (97.4)	7.3 (64.6)	5.6	1FK7063 - 5AF71- 1 ■ ■ ■ ■	4	15.1 (13.4)	11.5 (25.4)
	80	2.14 (2.87)	8 (70.8)	6.8 (60.2)	4.4	1FK7080 - 5AF71- 1 ■ ■ ■ ■	4	15 (13.3)	10 (22.1)
		3.3 (4.43)	16 (142)	10.5 (92.9)	7.4	1FK7083 - 5AF71- 1 ■ ■ ■ ■	4	27.3 (24.2)	14 (30.9)
100	3.77 (5.06)	18 (159)	12 (106)	8	1FK7100 - 5AF71- 1 ■ ■ ■ ■	4	55.3 (48.9)	19 (41.9)	
	4.87 (6.53)	27 (239)	15.5 (137)	11.8	1FK7101 - 5AF71- 1 ■ ■ ■ ■	4	79.9 (70.7)	21 (46.3)	
	5.37 (7.20) ²⁾	36 (319)	20.5 (181) ²⁾	16.5 ²⁾	1FK7103 - 5AF71- 1 ■ ■ ■ ■	4	105 (92.9)	29 (63.9)	
	8.17 (11.0)	48 (425)	26 (230)	18	1FK7105 - 5AF71- 1 ■ ■ ■ ■	4	156 (138)	39 (86.0)	

Encoder systems for motors without DRIVE-CLiQ interface:	Incremental encoder sin/cos 1 V _{pp} , 2048 S/R	A E G S T				
	Absolute encoder EnDat 2048 S/R ¹⁾ Absolute encoder EnDat 32 S/R ¹⁾ Multi-pole resolver 2-pole resolver					
Encoder systems for motors with DRIVE-CLiQ interface:	Incremental encoder 22 bit	D F K U P				
	Absolute encoder 22 bit single-turn + 12 bit multi-turn ¹⁾ Absolute encoder 16 bit single-turn + 12 bit multi-turn ¹⁾ 15 bit resolver 14 bit resolver					
Shaft extension: Fitted key and keyway Fitted key and keyway Plain shaft Plain shaft	Shaft and flange accuracy: Tolerance N Tolerance N Tolerance N Tolerance N	Holding brake: without with without with	A B G H			
				Degree of protection:	0 2 3 5 8	
						IP64 (not for 1FK701)
						IP65 and DE flange IP67 (not for 1FK701)
IP64 (IP54 with 1FK701) and anthracite paint finish IP65 and DE flange IP67, anthracite paint finish (not for 1FK701) IP65 and DE flange IP67, anthracite paint finish and metal rating plate on motor (not for 1FK701)						

To select the degree of protection and type, see Selection guides.

Synchronous motors

Feed motors for SINAMICS S120

1FK7 Compact motors
Natural cooling

Selection and Ordering Data

Motor type (continued)	Static current I_0 at M_0 $\Delta T=100$ K A	Calculated power P_{calc} ⁵⁾ P_{calc} for M_0 $\Delta T=100$ K kW (HP)	SINAMICS S120 Motor Module		Power cable with complete shield Motor connection (and brake connection) via power connector		
			Rated output current ⁴⁾ I_{rated} A	Booksize format Order No.	Power connector Size	Motor cable cross- section ³⁾ mm ²	Order No. Pre-assembled cable
1FK7105-5AC71...	20	10 (13.4)	30	6SL312 - TE23 - 0AA3	1.5	4 x 2.5	6FX 002 - 5S31 -
1FK7042-5AF71...	2.2	0.9 (1.21)	3	6SL312 - TE13 - 0AA3	1	4 x 1.5	6FX 002 - 5S01 -
1FK7060-5AF71...	4.5	1.9 (2.55)	5	6SL312 - TE15 - 0AA3	1	4 x 1.5	6FX 002 - 5S01 -
1FK7063-5AF71...	8	3.5 (4.69)	9	6SL312 - TE21 - 0AA3	1	4 x 1.5	6FX 002 - 5S01 -
1FK7080-5AF71...	4.8	2.5 (3.35)	5	6SL312 - TE15 - 0AA3	1	4 x 1.5	6FX 002 - 5S01 -
1FK7083-5AF71...	10.4	5.0 (6.71)	9 ³⁾	6SL312 - TE21 - 0AA3	1	4 x 1.5	6FX 002 - 5S01 -
1FK7100-5AF71...	11.2	5.7 (7.64)	18	6SL312 - TE21 - 8AA3	1	4 x 1.5	6FX 002 - 5S01 -
1FK7101-5AF71...	19	8.5 (11.4)	18 ³⁾	6SL312 - TE21 - 8AA3	1.5	4 x 2.5	6FX 002 - 5S31 -
1FK7103-5AF71...	27.5	11.3 (15.2)	30	6SL312 - 1TE23 - 0AA3	1.5	4 x 4	6FX 002 - 5S41 -
1FK7105-5AF71...	31	15 (20.1)	30 ³⁾	6SL312 - 1TE23 - 0AA3	1.5	4 x 10	6FX 002 - 5S61 -
Cooling:							
Internal air cooling				0			
External air cooling				1			
Motor Module:							
Single Motor Module				1			
Double Motor Module				2			
Type of power cable:							
MOTION-CONNECT 800						8	
MOTION-CONNECT 500						5	
Without brake cores							C
With brake cores							D
For length code as well as power and signal cables, see Connection system MOTION-CONNECT.						

6

¹⁾ If the absolute encoder is used, M_{rated} is reduced by 10%.

²⁾ These values refer to $n = 2500$ rpm.

³⁾ The current carrying capacity of the power cables complies with IEC 60204-1 for installation type C under continuous operating conditions at an ambient air temperature of 40 °C (104 °F), designed for I_0 (100 K), PVC/PUR-insulated cable.

⁴⁾ With default setting of the pulse frequency.

⁵⁾ $P_{calc} [kW] = \frac{M_0 [Nm] \times n_{rated}}{9550}$ $P_{calc} [HP] = \frac{M_0 [lb_f-in] \times n_{rated}}{63000}$

Synchronous motors

Feed motors for SINAMICS S120

1FK7 Compact motors Natural cooling

Selection and Ordering Data

Rated speed	Shaft height	Rated power	Static torque	Rated torque ¹⁾	Rated current	1FK7 Compact synchronous motor Natural cooling	Number of pole pairs	Rotor moment of inertia (without brake)	Weight (without brake)
n_{rated}	SH	P_{rated} at $\Delta T=100$ K	M_0 at $\Delta T=100$ K	M_{rated} at $\Delta T=100$ K	I_{rated} at $\Delta T=100$ K	Order No.		J	m
rpm		kW (HP)	Nm (lb _f -in)	Nm (lb _f -in)	A			10^{-4} kgm ² (10^{-3} x lb _f -in-s ²)	kg (lb)
4500	63	1.74 (2.33)	6 (53.1)	3.7 (32.7)	4.1	1FK7060 - 5AH71- 1 ■ ■ ■	4	7.95 (7.04)	7 (15.4)
		2.09 (2.80) ²⁾	11 (97.4)	5 (44.3) ²⁾	6.1 ²⁾	1FK7063 - 5AH71- 1 ■ ■ ■	4	15.1 (13.4)	11.5 (25.4)
	80	2.39 (3.20) ²⁾	8 (70.8)	5.7 (50.5) ²⁾	5.6 ²⁾	1FK7080 - 5AH71- 1 ■ ■ ■	4	15 (13.3)	10 (22.1)
		3.04 (4.08) ³⁾	16 (142)	8.3 (73.5) ³⁾	9 ³⁾	1FK7083 - 5AH71- 1 ■ ■ ■	4	27.3 (24.2)	14 (30.9)
6000	20	0.05 (0.07)	0.18 (1.59)	0.08 (0.71)	0.85	1FK7011 - 5AK71- 1 ■ ■ ■ 3	4	0.064 (0.06)	0.9 (1.98)
		0.10 (0.13)	0.35 (3.10)	0.16 (1.42)	0.85	1FK7015 - 5AK71- 1 ■ ■ ■ 3	4	0.083 (0.07)	1.1 (2.43)
	28	0.43 (0.58)	0.85 (7.52)	0.6 (5.31)	1.4	1FK7022 - 5AK71- 1 ■ ■ ■	3	0.28 (0.25)	1.8 (3.97)
		0.50 (0.67)	1.1 (9.74)	0.8 (7.08)	1.3	1FK7032 - 5AK71- 1 ■ ■ ■	3	0.61 (0.54)	2.7 (5.95)
	36	0.63 (0.84)	1.6 (14.2)	1 (8.85)	1.3	1FK7034 - 5AK71- 1 ■ ■ ■	3	0.9 (0.80)	3.7 (8.16)
		0.69 (0.93)	1.6 (14.2)	1.1 (9.74)	1.7	1FK7040 - 5AK71- 1 ■ ■ ■	4	1.69 (1.50)	3.5 (7.72)
48	1.02 (1.37) ⁴⁾	3 (26.6)	1.95 (17.3) ⁴⁾	3.1 ⁴⁾	1FK7042 - 5AK71- 1 ■ ■ ■	4	3.01 (2.66)	4.9 (10.8)	

Encoder systems for motors without DRIVE-CLiQ interface:

Incremental encoder sin/cos 1V_{pp} 2048 S/R
 Absolute encoder EnDat 2048 S/R (not for 1FK701...1FK703)¹⁾
 Absolute encoder EnDat 512 S/R (only for 1FK701...1FK703)¹⁾
 Absolute encoder EnDat 32 S/R (not for 1FK701...1FK703)¹⁾
 Absolute encoder EnDat 16 S/R (only for 1FK701...1FK703)¹⁾
 Multi-pole resolver
 2-pole resolver

A
E
H
G
J
S
T

Encoder systems for motors with DRIVE-CLiQ interface:⁵⁾

Incremental encoder 22 bit (not for 1FK701)
 Absolute encoder 22 bit single-turn + 12 bit multi-turn¹⁾ (not for 1FK701 ... 1FK703)
 Absolute encoder 20 bit single-turn + 12 bit multi-turn¹⁾ (only for 1FK701 ... 1FK703)
 Absolute encoder 16 bit single-turn + 12 bit multi-turn¹⁾ (not for 1FK701 ... 1FK703)
 Absolute encoder 15 bit single-turn + 12 bit multi-turn¹⁾ (only for 1FK701 ... 1FK703)
 15 bit resolver (not for 1FK701)
 14 bit resolver (not for 1FK701)

D
F
L
K
V
U
P

Shaft extension:

Fitted key and keyway
 Fitted key and keyway
 Plain shaft
 Plain shaft

Shaft and flange accuracy:

Tolerance N
 Tolerance N
 Tolerance N
 Tolerance N

Holding brake:

without
 with
 without
 with

A
B
G
H

Degree of protection:

IP64 (not for 1FK701)
 IP65 and DE flange IP67 (not for 1FK701)
 IP64 (IP54 with 1FK701) and anthracite paint finish
 IP65 and DE flange IP67, anthracite paint finish (not for 1FK701)
 IP65 and DE flange IP67, anthracite paint finish and metal rating plate on motor (not for 1FK701)

0
2
3
5
8

To select the degree of protection and type, see Selection guides.

Synchronous motors

Feed motors for SINAMICS S120

1FK7 Compact motors
Natural cooling
Selection and Ordering Data

Motor type (continued)	Static current I_0 at M_0 $\Delta T=100$ K A	Calculated power P_{calc} ⁸⁾ P_{calc} for M_0 $\Delta T=100$ K kW (HP)	SINAMICS S120 Motor Module		Power cable with complete shield Motor connection (and brake connection) via power connector		
			Rated output current ⁷⁾ I_{rated} A	Booksized format Order No.	Power connector Size	Motor cable cross- section ⁶⁾ mm ²	Order No. Pre-assembled cable
1FK7060-5AH71...	6.2	2.8 (3.75)	9	6SL312 - TE21 - 0AA3	1	4 x 1.5	6FX 002 - 5S01 -
1FK7063-5AH71...	12	5.2 (6.97)	18	6SL312 - TE21 - 8AA3	1	4 x 1.5	6FX 002 - 5S01 -
1FK7080-5AH71...	7.4	3.8 (5.10)	9	6SL312 - TE21 - 0AA3	1	4 x 1.5	6FX 002 - 5S01 -
1FK7083-5AH71...	15	7.5 (10.1)	18	6SL312 - TE21 - 8AA3	1	4 x 1.5	6FX 002 - 5S01 -
1FK7011-5AK71...	1.5	0.11 (0.15)	3	6SL312 - TE13 - 0AA3	0.5	4 x 1.5	6FX5 002 - 5DA20 -
1FK7015-5AK71...	1.5	0.22 (0.30)	3	6SL312 - TE13 - 0AA3	0.5	4 x 1.5	6FX5 002 - 5DA20 -
1FK7022-5AK71...	1.8	0.5 (0.67)	3	6SL312 - TE13 - 0AA3	1	4 x 1.5	6FX 002 - 5S01 -
1FK7032-5AK71...	1.7	0.7 (0.94)	3	6SL312 - TE13 - 0AA3	1	4 x 1.5	6FX 002 - 5S01 -
1FK7034-5AK71...	1.9	1 (1.34)	3	6SL312 - TE13 - 0AA3	1	4 x 1.5	6FX 002 - 5S01 -
1FK7040-5AK71...	2.25	1.0 (1.34)	3	6SL312 - TE13 - 0AA3	1	4 x 1.5	6FX 002 - 5S01 -
1FK7042-5AK71...	4.4	1.9 (2.55)	5	6SL312 - TE15 - 0AA3	1	4 x 1.5	6FX 002 - 5S01 -
Cooling:							
Internal air cooling				0			
External air cooling				1			
Motor Module:							
Single Motor Module				1			
Double Motor Module				2			
Type of power cable:							
MOTION-CONNECT 800						8	
MOTION-CONNECT 500						5	
Without brake cores							C
With brake cores							D
For length code as well as power and signal cables, see Connection system MOTION-CONNECT.						

6

¹⁾ If the absolute encoder is used, M_{rated} is reduced by 10%.

²⁾ These values refer to $n = 4000$ rpm.

³⁾ These values refer to $n = 3500$ rpm.

⁴⁾ These values refer to $n = 5000$ rpm.

⁵⁾ Motors with shaft height 20 are not available with a DRIVE-CLiQ interface. The encoder systems are connected via the SMC (Sensor Module Cabinet-Mounted).

⁶⁾ The current carrying capacity of the power cables complies with IEC 60204-1 for installation type C under continuous operating conditions at an ambient air temperature of 40 °C (104 °F), designed for I_0 (100 K), PVC/PUR-insulated cable.

⁷⁾ With default setting of the pulse frequency.

⁸⁾ $P_{calc} [kW] = \frac{M_0 [Nm] \times n_{rated}}{9550}$ $P_{calc} [HP] = \frac{M_0 [lb_f-in] \times n_{rated}}{63000}$

Synchronous motors

Feed motors for SINAMICS S120

1FK7 High Dynamic motors Natural cooling

Selection and Ordering Data

Rated speed	Shaft height	Rated power	Static torque	Rated torque ¹⁾	Rated current	1FK7 High Dynamic synchronous motor Natural cooling	Number of pole pairs	Rotor moment of inertia (without brake)	Weight (without brake)
n_{rated}	SH	P_{rated} at $\Delta T=100$ K	M_0 at $\Delta T=100$ K	M_{rated} at $\Delta T=100$ K	I_{rated} at $\Delta T=100$ K	Order No.		J	m
rpm		kW (HP)	Nm (lb _f -in)	Nm (lb _f -in)	A			10^{-4} kgm ² (10^{-3} x lb _f -in-s ²)	kg (lb)
3000	48	1.1 (1.48)	4 (35.4)	3.5 (31.0)	4	1FK7044 - 7AF71- 1 ■ ■ ■ ■	3	1.28 (1.13)	7.7 (17.0)
	63	1.7 (2.28)	6.4 (56.6)	5.4 (47.8)	5.3	1FK7061 - 7AF71- 1 ■ ■ ■ ■	3	3.4 (3.01)	10 (22.1)
		2.51 (3.37)	12 (106)	8 (70.8)	7.5	1FK7064 - 7AF71- 1 ■ ■ ■ ■	3	6.5 (5.75)	15.5 (34.2)
	80	3.14 (4.21) ²⁾	22 (195)	12 (106) ²⁾	12.5 ²⁾	1FK7085 - 7AF71- 1 ■ ■ ■ ■	4	23 (20.4)	23.5 (51.8)
3.77 (5.06) ³⁾		28 (248)	18 (159) ³⁾	14.5 ³⁾	1FK7086 - 7AF71- 1 ■ ■ ■ ■	4	23 (20.4)	23.5 (51.8)	
4500	48	1.23 (1.65)	3.1 (27.4)	2.6 (23.0)	4	1FK7043 - 7AH71- 1 ■ ■ ■ ■	3	1 (0.89)	6.3 (13.9)
		1.41 (1.89)	4 (35.4)	3 (26.6)	4.9	1FK7044 - 7AH71- 1 ■ ■ ■ ■	3	1.28 (1.13)	7.7 (17.0)
	63	2.03 (2.72)	6.4 (56.6)	4.3 (38.1)	5.9	1FK7061 - 7AH71- 1 ■ ■ ■ ■	3	3.4 (3.01)	10 (22.1)
		2.36 (3.16)	12 (106)	5 (44.3)	7	1FK7064 - 7AH71- 1 ■ ■ ■ ■	3	6.5 (5.75)	15.5 (34.2)
6000	36	0.57 (0.76)	1.3 (11.5)	0.9 (7.97)	1.5	1FK7033 - 7AK71- 1 ■ ■ ■ ■	3	0.27 (0.24)	3.1 (6.84)
	48	1.26 (1.69)	3.1 (27.4)	2 (17.7)	4.4	1FK7043 - 7AK71- 1 ■ ■ ■ ■	3	1 (0.89)	6.3 (13.9)
Encoder systems for motors without DRIVE-CLiQ interface:		Incremental encoder sin/cos 1 V _{pp} 2048 S/R Absolute encoder EnDat 2048 S/R (not for 1FK703) ¹⁾ Absolute encoder EnDat 512 S/R (only for 1FK703) ¹⁾ Absolute encoder EnDat 32 S/R (not for 1FK703) ¹⁾ Absolute encoder EnDat 16 S/R (only for 1FK703) ¹⁾ Multi-pole resolver 2-pole resolver				A E H G J S T			
Encoder systems for motors with DRIVE-CLiQ interface:		Incremental encoder 22 bit Absolute encoder 22 bit single-turn + 12 bit multi-turn ¹⁾ (not for 1FK703) Absolute encoder 20 bit single-turn + 12 bit multi-turn ¹⁾ (only for 1FK703) Absolute encoder 16 bit single-turn + 12 bit multi-turn ¹⁾ (not for 1FK703) Absolute encoder 15 bit single-turn + 12 bit multi-turn ¹⁾ (only for 1FK703) 15 bit resolver 14 bit resolver				D F L K V U P			
Shaft extension: Fitted key and keyway Fitted key and keyway Plain shaft Plain shaft		Shaft and flange accuracy: Tolerance N Tolerance N Tolerance N Tolerance N		Holding brake: without with without with		A B G H			
Degree of protection:		IP64 IP65 and drive end flange IP67 IP64 and anthracite paint finish IP65 and DE flange IP67, anthracite paint finish IP65 and DE flange IP67, anthracite paint finish and metal rating plate on motor				0 2 3 5 8			

To select the degree of protection and type, see Selection guides.

Synchronous motors

Feed motors for SINAMICS S120

1FK7 High Dynamic motors
Natural cooling

Selection and Ordering Data

Motor type (continued)	Static current I_0 at M_0 $\Delta T=100$ K A	Calculated power P_{calc} ⁶⁾ P_{calc} for M_0 $\Delta T=100$ K kW (HP)	SINAMICS S120 Motor Module		Power cable with complete shield Motor connection (and brake connection) via power connector		
			Rated output current ⁵⁾ I_{rated} A	Booksize format Order No.	Power connector Size	Motor cable cross-section ⁴⁾ mm ²	Order No. Pre-assembled cable
1FK7044-7AF71...	4.5	1.3 (1.74)	5	6SL312 - TE15 - 0AA3	1	4 x 1.5	6FX 002 - 5S01 -
1FK7061-7AF71...	6.1	2.0 (2.68)	9	6SL312 - TE21 - 0AA3	1	4 x 1.5	6FX 002 - 5S01 -
1FK7064-7AF71...	11	3.8 (5.10)	18	6SL312 - TE21 - 8AA3	1	4 x 1.5	6FX 002 - 5S01 -
1FK7085-7AF71...	22.5	6.9 (9.25)	30	6SL312 - 1TE23 - 0AA3	1.5	4 x 4	6FX 002 - 5S41 -
1FK7086-7AF71...	21	8.8 (11.8)	30	6SL312 - 1TE23 - 0AA3	1.5	4 x 4	6FX 002 - 5S41 -
1FK7043-7AH71...	4.5	1.5 (2.01)	5	6SL312 - TE15 - 0AA3	1	4 x 1.5	6FX 002 - 5S01 -
1FK7044-7AH71...	6.3	1.9 (2.55)	9	6SL312 - TE21 - 0AA3	1	4 x 1.5	6FX 002 - 5S01 -
1FK7061-7AH71...	8	3.0 (4.02)	9	6SL312 - TE21 - 0AA3	1	4 x 1.5	6FX 002 - 5S01 -
1FK7064-7AH71...	15	5.7 (7.64)	18	6SL312 - TE21 - 8AA3	1	4 x 1.5	6FX 002 - 5S01 -
1FK7033-7AK71...	2.2	0.8 (1.07)	3	6SL312 - TE13 - 0AA3	1	4 x 1.5	6FX 002 - 5S01 -
1FK7043-7AK71...	6.4	1.9 (2.55)	9	6SL312 - TE21 - 0AA3	1	4 x 1.5	6FX 002 - 5S01 -

Cooling: Internal air cooling	0
External air cooling	1
Motor Module: Single Motor Module	1
Double Motor Module	2
Type of power cable: MOTION-CONNECT 800	8
MOTION-CONNECT 500	5
Without brake cores	C
With brake cores	D
For length code as well as power and signal cables, see Connection system MOTION-CONNECT.

6

¹⁾ If the absolute encoder is used, M_{rated} is reduced by 10%.

²⁾ These values refer to $n = 2500$ rpm.

³⁾ These values refer to $n = 2000$ rpm.

⁴⁾ The current carrying capacity of the power cables complies with IEC 60204-1 for installation type C under continuous operating conditions at an ambient air temperature of 40 °C (104 °F), designed for I_0 (100 K), PVC/PUR-insulated cable.

⁵⁾ With default setting of the pulse frequency.

⁶⁾ $P_{calc} [kW] = \frac{M_0 [Nm] \times n_{rated}}{9550}$ $P_{calc} [HP] = \frac{M_0 [lb_f-in] \times n_{rated}}{63000}$

Synchronous motors

Feed motors for SINAMICS S120

1FK7 Compact/High Dynamic motors Natural cooling for Power Modules

Selection and Ordering Data

Rated speed	Shaft height	Rated power	Static torque	Rated torque ¹⁾	Rated current	1FK7 Compact/ 1FK7 High Dynamic synchronous motor Natural cooling Connection to SINAMICS 230 V 1 AC	Number of pole pairs	Rotor moment of inertia (without brake)	Weight (without brake)
n_{rated}	SH	P_{rated} at $\Delta T=100\text{ K}$	M_0 at $\Delta T=100\text{ K}$	M_{rated} at $\Delta T=100\text{ K}$	I_{rated} at $\Delta T=100\text{ K}$	Order No.		J	m
rpm		kW (HP)	Nm (lb _f -in)	Nm (lb _f -in)	A			10^{-4} kgm^2 (10^{-3} x lb _f -in-s ²)	kg (lb)
3000	36	0.31 (0.42)	1.15 (10.2)	1.0 (8.85)	1.6	1FK7032 - 5AF21- 1 ■ ■ ■	3	0.61 (0.54)	2.7 (5.95)
		0.38 (0.51)	1.3 (11.5)	1.2 (10.6)	2	1FK7033 - 7AF21- 1 ■ ■ ■	3	0.27 (0.24)	3.1 (6.84)
		0.46 (0.62)	1.6 (14.2)	1.45 (12.8)	1.8	1FK7034 - 5AF21- 1 ■ ■ ■	3	0.9 (0.80)	3.7 (8.16)
6000	20	0.82 (1.10)	3 (26.6)	2.6 (23.0)	3.5	1FK7042 - 5AF21- 1 ■ ■ ■	4	3.01 (2.66)	4.9 (10.8)
		0.79 (1.06)	2.7 (23.9)	2.5 (22.1)	3.8	1FK7043 - 7AF21- 1 ■ ■ ■	3	1 (0.89)	6.3 (13.9)
6000	28	0.05 (0.07)	0.18 (1.59)	0.08 (0.71)	0.5	1FK7011 - 5AK21-1 ■ ■ ■ 3	4	0.064 (0.06)	0.9 (1.98)
		0.10 (0.13)	0.35 (3.10)	0.16 (0.42)	0.5	1FK7015 - 5AK21-1 ■ ■ ■ 3	4	0.083 (0.07)	1.1 (2.43)
		0.38 (0.51)	0.85 (7.52)	0.6 (5.31)	1.4	1FK7022 - 5AK21-1 ■ ■ ■	3	0.28 (0.25)	1.8 (3.97)

Synchronous motor:

1FK7 Compact
1FK7 High Dynamic

5
7

Encoder systems for motors without DRIVE-CLiQ interface:

Incremental encoder sin/cos 1 V_{pp} 2048 S/R
Absolute encoder EnDat 2048 S/R (only for 1FK704)¹⁾
Absolute encoder EnDat 512 S/R (not for 1FK704)¹⁾
Absolute encoder EnDat 32 S/R (only for 1FK704)¹⁾
Absolute encoder EnDat 16 S/R (not for 1FK704)¹⁾
Multi-pole resolver
2-pole resolver

A
E
H
G
J
S
T

Encoder systems for motors with DRIVE-CLiQ interface:⁴⁾

Incremental encoder 22 bit
(not for 1FK701)
Absolute encoder 22 bit single-turn + 12 bit multi-turn¹⁾
(only for 1FK704)
Absolute encoder 20 bit single-turn + 12 bit multi-turn¹⁾
(only for 1FK702/1FK703)
Absolute encoder 16 bit single-turn + 12 bit multi-turn¹⁾
(only for 1FK704)
Absolute encoder 15 bit single-turn + 12 bit multi-turn¹⁾
(not for 1FK704)
15 bit resolver (not for 1FK701)
14 bit resolver (not for 1FK701)

D
F
L
K
V
U
P

Shaft extension:

Fitted key and keyway
Fitted key and keyway
Plain shaft
Plain shaft

Shaft and flange accuracy:

Tolerance N
Tolerance N
Tolerance N
Tolerance N

Holding brake:

without
with
without
with

A
B
G
H

Degree of protection:

IP64 (not for 1FK701)
IP65 and DE flange IP67 (not for 1FK701)
IP64 (IP54 with 1FK701) and anthracite paint finish
IP65 and DE flange IP67, anthracite paint finish
(not for 1FK701)
IP65 and DE flange IP67, anthracite paint finish and
metal rating plate on motor (not for 1FK701)

0
2
3
5
8

To select the degree of protection and type, see Selection guides.

Synchronous motors

Feed motors for SINAMICS S120

1FK7 Compact/High Dynamic motors
Natural cooling for Power Modules

Selection and Ordering Data

Motor type (continued)	Static current I_0 at M_0 $\Delta T=100$ K A	Calculated power P_{calc} ⁶⁾ P_{calc} for M_0 $\Delta T=100$ K kW (HP)	SINAMICS S120 Power Module		Power cable with complete shield Motor connection (and brake connection) via power connector		
			Rated output current ⁵⁾ I_{rated} A	Blocksize format without line filter Order No.	Power connector Size	Motor cable cross-section ³⁾ mm ²	Order No. Pre-assembled cable
1FK7032-5AF21...	1.7	0.36 (0.48)	2.3	6SL3210-1SB12-3UA0	1	4 x 1.5	6FX 002 - 5 G01 -
1FK7033-7AF21...	2.1	0.41 (0.55)	2.3	6SL3210-1SB12-3UA0	1	4 x 1.5	6FX 002 - 5 G01 -
1FK7034-5AF21...	1.9	0.5 (0.67)	2.3	6SL3210-1SB12-3UA0	1	4 x 1.5	6FX 002 - 5 G01 -
1FK7042-5AH21...	3.9	0.94 (1.26)	3.9	6SL3210-1SB14-0UA0	1	4 x 1.5	6FX 002 - 5 G01 -
1FK7043-7AH21...	3.9	0.85 (1.14)	3.9	6SL3210-1SB14-0UA0	1	4 x 1.5	6FX 002 - 5 G01 -
1FK7011-5AK21...	0.85	0.11 (0.15)	0.9	6SL3210-1SB11-0UA0	0.5	4 x 1.5	6FX5 002 - 5DA30 -²⁾
1FK7015-5AK21...	0.85	0.22 (0.30)	0.9	6SL3210-1SB11-0UA0	0.5	4 x 1.5	6FX5 002 - 5DA30 -²⁾
1FK7022-5AK21...	1.8	0.53 (0.71)	2.3	6SL3210-1SB12-3UA0	1	4 x 1.5	6FX 002 - 5 G01 -
Type of power cable:							
MOTION-CONNECT 800							8
MOTION-CONNECT 500							5
Without brake cores							C
With brake cores							D
For length code as well as power and signal cables, see Connection system MOTION-CONNECT.						

¹⁾ If the absolute encoder is used, M_{rated} is reduced by 10%.

²⁾ This power cable is fitted with a connector with M17 thread at the motor end and brake cores as standard (4 x 1.5 mm² + 2 x 1.5 mm²).

³⁾ The current carrying capacity of the power cables complies with IEC 60204-1 for installation type C under continuous operating conditions at an ambient air temperature of 40 °C (104 °F), designed for I_0 (100 K), PVC/PUR-insulated cable.

⁴⁾ Motors with shaft height 20 are not available with a DRIVE-CLiQ interface. The encoder systems are connected via the SMC (Sensor Module Cabinet-Mounted).

⁵⁾ With default setting of the pulse frequency.

⁶⁾ P_{calc} [kW] = $\frac{M_0 \text{ [Nm]} \times n_{rated}}{9550}$ P_{calc} [HP] = $\frac{M_0 \text{ [lb}_f\text{-in]} \times n_{rated}}{63000}$

Synchronous motors

Gearboxes

Series SP+ planetary gearbox for 1FT6 motors

Overview

1FT6 motors can be combined with planetary gearboxes to form compact coaxial drive units. The gearboxes are flanged directly to the drive end of the motors.

When selecting the gearboxes, ensure that the permissible speed of the gearbox is not exceeded by the maximum speed of the motor. In the case of high operating frequencies, allowance must be made for the factor f_2 (see Configuration Manual for synchronous motors). The frictional losses of the gearbox must always be taken into account in planning.

The gearboxes are only available in non-balanced design.

Benefits

- High efficiency
Single-stage: > 97%
Two-stage: > 94%
- Minimum torsional backlash
Single-stage: ≤ 4 arcmin
Two-stage: ≤ 6 arcmin
- Power transmission from the central sun wheel via planet wheels
- No shaft deflections in the planet wheel set due to symmetrical force distribution
- Very low moment of inertia and hence short acceleration times of the motors
- Output shaft bearings dimensioned for high lateral and axial loads with preloaded tapered-roller bearings
- The gearboxes are connected to the motor shaft via an integrated clamping hub. A plain motor shaft extension is necessary for this purpose. Shaft and flange accuracy tolerance N in accordance with DIN 42955 and vibration magnitude grade A in accordance with EN 60034-14 are sufficient. The motor flange is adapted by means of adapter plates.
- Output shaft of gearbox exactly coaxial with the motor
- The gearboxes are enclosed (seal between gearbox and motor) and filled with oil at the factory. They are lubricated and sealed for their service life. Gearboxes of frame sizes SP 060S to SP 180S are suitable for all mounting positions. The oil filling quantity for gearboxes of frame sizes SP 210 and SP 240 depends on the mounting position. The mounting position has to be specified when ordering.
- Degree of protection of gearbox: IP65 (IP64 for frame sizes SP 210/SP 240)
- Small dimensions
- Low weight



Synchronous motor with mounted planetary gearbox series SP+

Integration

1FT602 and 1FT613 motors can be supplied ex works (Siemens AG) complete with flange-mounted planetary gearbox.

The gearboxes assigned to the individual motors and gear ratios i available for these motor/gearbox combinations are listed in the selection table. When making a selection, account must be taken of the maximum permissible input speed of the gearbox (this is the same as the maximum motor speed).

The motor/gearbox combinations listed in the selection tables are mainly intended for cycle operation S3-60% (ON time ≤ 60% and ≤ 20 min). Reduced maximum motor speeds and output torques apply for use in S1 continuous duty (ON time > 60% or > 20 min). The gearbox temperature must not exceed 90 °C (194 °F).

Follow the instructions contained in the Configuration Manual for synchronous motors when assigning gearboxes to the motor.

1FT6 motors must be designed with plain motor shaft extension, shaft and flange accuracy tolerance N and vibration magnitude grade A/degree of protection IP65 (for 1FT602: IP64) for mounting onto the gearbox.

Synchronous motors

Gearboxes

Series SP+ planetary gearboxes, single-stage for 1FT6 motors

Selection and Ordering Data

Motor	Planetary gearbox Single-stage			Available gear ratios $i =$				Motor speed, max. S3-60%	Output torque, max. S3-60%	Radial load on output shaft, max. ¹⁾	Axial load on output shaft, max. ¹⁾
				4	5	7	10				
Type	Type	Torsional backlash arcmin	Weight of gearbox, approx. kg (lb)					n_{G1}	M_{G2}	F_r	F_a
								(n_1)	(T_{2B})	(F_{2Rmax})	(F_{2Amax})
								rpm	Nm (lb _f -ft)	N (lb _f)	N (lb _f)
1FT6021 1FT6024	SP 060S-MF1	≤ 4	1.9 (4.19)	- ✓	- ✓	- ✓	✓ ✓	6000	40 (29.5) (32 (23.6) for $i = 10$)	2700 (607)	2400 (540)
1FT6031 1FT6034				✓ ✓	✓ ✓	✓ ✓	✓ -				
1FT6034 1FT6041 1FT6044	SP 075S-MF1	≤ 4	3.9 (8.6)	- ✓ ✓	- ✓ ✓	- ✓ ✓	✓ ✓ ✓	6000	110 (81.1) (90 (66.4) for $i = 10$)	4000 (899)	3350 (753)
1FT6061 1FT6062 1FT6064	SP 100S-MF1	≤ 3	7.7 (17)	✓ ✓ ✓	✓ ✓ ✓	✓ ✓ ✓	✓ ✓ ✓	4500	300 (221) (225 (167) for $i = 10$)	6300 (1416)	5650 (1270)
1FT6081 1FT6082 1FT6084 1FT6086	SP 140S-MF1	≤ 3	17.2 (37.9)	✓ ✓ ✓ ✓	✓ ✓ ✓ ✓	✓ ✓ ✓ ✓	✓ ✓ ✓ -	4000	600 (442) (480 (354) for $i = 10$)	9450 (2124)	9870 (2219)
1FT6086 1FT6102 1FT6105 1FT6108	SP 180S-MF1	≤ 3	34 (75)	- ✓ ✓ ✓	- ✓ ✓ ✓	- ✓ ✓ ✓	✓ ✓ -	3500	1100 (811) (880 (649) for $i = 10$)	14700 (3305)	14150 (3181)
1FT6105 1FT6108	SP 210-MF1 ²⁾	≤ 4	53 (117)	- -	- -	- -	✓ ✓	2500	1900 (1400) (1520 (1120) for $i = 10$)	18000 (4047)	22500 (5058)
1FT6132 1FT6134 1FT6136				✓ ✓ ✓	✓ ✓ ✓	✓ ✓ ✓	✓ -				
1FT6134 1FT6136	SP 240-MF1 ²⁾	≤ 4	80 (176)	- -	- -	- -	✓ ✓	2200	2720 (2005)	27000 (6070)	27800 (6250)

Order codes

- Gearbox shaft with fitted key
- Gearbox shaft without fitted key

J02 J03 J05 J09
J22 J23 J25 J29

Ordering data:

1FT6...-...71-...-1-Z

J ■ ■

G

without holding brake
with holding brake

Order No. of the motor with identifier "-Z" and order code for mounting the planetary gearbox assigned to the motor
Preconditions for mounting planetary gearboxes:
Plain motor shaft extension/shaft and flange accuracy tolerance N and vibration magnitude grade A/IP65 degree of protection³⁾

✓ Possible

- Not possible

¹⁾ In reference to the output shaft center.

²⁾ For these versions, the quantity of oil in the gearbox depends on the mounting position. In the case of a vertical mounting position, the 12th position in the Order No. should be '9' and a further order code also has to be specified: 1FT6...-...79-...-1-Z J.. + M1 ■

³⁾ IP64 degree of protection with 1FT602.: 1FT602.-6AK71-...-0-Z J..

G
H

H
H

H Mounting position IM V1
G Mounting position IM V3

Synchronous motors

Gearboxes

Series SP+ planetary gearboxes, single-stage for 1FT6 motors

Technical specifications

Planetary gearbox with 1FT6 motor										
Single-stage Type	Gear ratio	Motor speed	Output torque	Moments of inertia of gearbox (referred to the drive)						
				Continuous duty S1 ¹⁾						
				$n_{rated\ 1}$ rpm	$M_{rated\ 2}$ ($T_{2\ rated}$) Nm (lb _f -in)	1FT602. J_1 kgcm ² (lb _f -in ²)	1FT603. J_1 kgcm ² (lb _f -in ²)	1FT604. J_1 kgcm ² (lb _f -in ²)	1FT606. J_1 kgcm ² (lb _f -in ²)	1FT608. J_1 kgcm ² (lb _f -in ²)
SP 060S-MF1	4	3300	26 (230)	0.16 (0.05)	0.24 (0.08)	–	–	–	–	–
	5	3300	26 (230)	0.13 (0.04)	0.22 (0.08)	–	–	–	–	–
	7	4000	26 (230)	0.11 (0.04)	0.19 (0.06)	–	–	–	–	–
	10	4000	17 (151)	0.10 (0.03)	0.18 (0.06)	–	–	–	–	–
SP 075S-MF1	4	2900	75 (664)	–	0.69 (0.24)	0.94 (0.32)	–	–	–	–
	5	2900	75 (664)	–	0.58 (0.20)	0.83 (0.28)	–	–	–	–
	7	3100	75 (664)	–	0.48 (0.16)	0.73 (0.25)	–	–	–	–
	10	3100	52 (460)	–	0.42 (0.14)	0.67 (0.23)	–	–	–	–
SP 100S-MF1	4	2500	180 (1593)	–	–	–	3.65 (1.25)	–	–	–
	5	2500	175 (1549)	–	–	–	2.99 (1.02)	–	–	–
	7	2800	170 (1505)	–	–	–	2.81 (0.96)	–	–	–
	10	2800	120 (1062)	–	–	–	2.58 (0.88)	–	–	–
SP 140S-MF1	4	2100	360 (3186)	–	–	–	–	14.3 (4.89)	–	–
	5	2100	360 (3186)	–	–	–	–	13.1 (4.48)	–	–
	7	2600	360 (3186)	–	–	–	–	12 (4.1)	–	–
	10	2600	220 (1947)	–	–	–	–	11.4 (3.90)	–	–
SP 180S-MF1	4	1500	750 (6638)	–	–	–	–	45.1 (15.4)	45.1 (15.4)	–
	5	1500	750 (6638)	–	–	–	–	36.4 (12.4)	36.4 (12.4)	–
	7	2300	750 (6638)	–	–	–	–	28.6 (9.77)	28.6 (9.77)	–
	10	2300	750 (6638)	–	–	–	–	24.4 (8.34)	24.4 (8.34)	–
SP 210-MF1	4	1200	1000 (8851)	–	–	–	–	–	75.8 (25.9)	75.8 (25.9)
	5	1200	1000 (8851)	–	–	–	–	–	63.5 (21.7)	63.5 (21.7)
	7	1700	1000 (8851)	–	–	–	–	–	52.9 (18.1)	52.9 (18.1)
	10	1700	1000 (8851)	–	–	–	–	–	47.1 (16.1)	47.1 (16.1)
SP 240-MF1	4	1000	1700 (15046)	–	–	–	–	–	–	146 (49.9)
	5	1000	1700 (15046)	–	–	–	–	–	–	120 (41.0)
	7	1500	1700 (15046)	–	–	–	–	–	–	96.4 (32.9)
	10	1500	1700 (15046)	–	–	–	–	–	–	83.1 (28.4)

¹⁾ The limit values in the table apply for S1 continuous duty (ON time > 60% or > 20 min) for a maximum gearbox temperature of 90 °C (194 °F).

Synchronous motors

Gearboxes

Series SP+ planetary gearbox, two-stage for 1FT6 motors

Selection and Ordering Data

Motor Type	Planetary gearbox Two-stage		Available gear ratios $i =$					Motor speed, max. S3-60% n_{G1} (n_1) rpm	Output torque, max. S3-60% M_{G2} (T_{2B}) Nm (lb _f -ft)	Radial load on output shaft, max. ¹⁾ F_r (F_{2Rmax}) N (lb _f)	Axial load on output shaft, max. ¹⁾ F_a (F_{2Amax}) N (lb _f)	
	Type	Torsional backlash arcmin	Weight of gearbox, approx. kg (lb)	16	20	28	40					50
1FT6021 1FT6024 1FT6031	SP 060S-MF2	≤ 6	2 (4.41)	✓	✓	✓	✓	✓	6000	40 (29.5)	2700 (607)	2400 (540)
1FT6024 1FT6031 1FT6034 1FT6041	SP 075S-MF2	≤ 6	3.6 (7.94)	-	-	-	-	✓	6000	110 (81.1)	4000 (899)	3350 (753)
1FT6034 1FT6041 1FT6044 1FT6061 1FT6062 1FT6064	SP 100S-MF2	≤ 5	7.9 (17.4)	-	-	-	✓	✓	4500	300 (221)	6300 (1416)	5650 (1270)
1FT6044 1FT6061 1FT6062 1FT6064 1FT6081 1FT6082 1FT6084	SP 140S-MF2	≤ 5	17 (37.5)	-	-	-	✓	✓	4000	600 (443)	9450 (2124)	9870 (2219)
1FT6064 1FT6081 1FT6082 1FT6084 1FT6086 1FT6102	SP 180S-MF2	≤ 5	36.4 (80.3)	-	-	-	✓	✓	4000	1100 (811)	14700 (3305)	14150 (3181)
1FT6082 1FT6105	SP 210-MF2 ²⁾	≤ 6	50 (110)	-	-	-	-	✓	3500	1900 (1401)	18000 (4047)	22500 (5058)
1FT6084 1FT6086 1FT6102 1FT6105 1FT6108 1FT6132 1FT6134 1FT6136	SP 240-MF2 ²⁾	≤ 6	70 (154)	-	-	-	✓	✓	3500	3400 (2508)	27000 (6070)	27800 (6250)

Order codes

- Gearbox shaft with fitted key
- Gearbox shaft without fitted key

J12 J13 J15 J16 J17
J32 J33 J35 J36 J37

Ordering data:

1FT6...-...71-...-Z

J ■ ■

G

without holding brake
with holding brake

H

Order No. of the motor with identifier "-Z" and order code for mounting the planetary gearbox assigned to the motor
Preconditions for mounting planetary gearboxes:
Plain motor shaft extension/shaft and flange accuracy tolerance N and vibration magnitude grade A/IP65 degree of protection³⁾

¹⁾ In reference to the output shaft center.

²⁾ For these versions, the quantity of oil in the gearbox depends on the mounting position. In the case of a vertical mounting position, the 12th position in the Order No. should be '9' and a further order code also has to be specified: 1FT6...-A.79-...-Z J.. + M1 ■

³⁾ IP64 degree of protection with 1FT602.: 1FT602.-6AK71-...-Z J..

G
H

G
H

H Mounting position IM V1
G Mounting position IM V3

Synchronous motors

Gearboxes

Series SP+ planetary gearbox, two-stage for 1FT6 motors

Technical specifications

Planetary gearbox with 1FT6 motor										
Two-stage Type	Gear ratio	Motor speed	Output torque	Moments of inertia of gearbox (referred to the drive)						
				Continuous duty S1 ¹⁾						
				$n_{rated\ 1}$	$M_{rated\ 2}$ ($T_{2\ rated}$)	1FT602. J_1	1FT603. J_1	1FT604. J_1	1FT606. J_1	1FT608. J_1
rpm	Nm (lb _f -in)	kgcm ² (lb _f -in ²)	kgcm ² (lb _f -in ²)	kgcm ² (lb _f -in ²)	kgcm ² (lb _f -in ²)	kgcm ² (lb _f -in ²)	kgcm ² (lb _f -in ²)	kgcm ² (lb _f -in ²)		
SP 060S-MF2	16	4400	26 (230)	0.08 (0.03)	0.18 (0.06)	–	–	–	–	–
	20	4400	26 (230)	0.07 (0.03)	0.17 (0.06)	–	–	–	–	–
	28	4400	26 (230)	0.06 (0.02)	0.16 (0.05)	–	–	–	–	–
	40	4400	26 (230)	0.06 (0.02)	0.16 (0.05)	–	–	–	–	–
	50	4800	26 (230)	0.06 (0.02)	0.16 (0.05)	–	–	–	–	–
SP 075S-MF2	16	3500	75 (664)	0.17 (0.06)	0.25 (0.08)	0.68 (0.23)	–	–	–	–
	20	3500	75 (664)	0.14 (0.05)	0.22 (0.08)	0.65 (0.22)	–	–	–	–
	28	3500	75 (664)	0.11 (0.04)	0.19 (0.06)	0.62 (0.21)	–	–	–	–
	40	3500	75 (664)	0.10 (0.03)	0.18 (0.06)	0.61 (0.21)	–	–	–	–
	50	3800	75 (664)	0.10 (0.03)	0.18 (0.06)	0.61 (0.21)	–	–	–	–
SP 100S-MF2	16	3100	180 (1593)	–	0.72 (0.25)	0.96 (0.33)	2.60 (0.89)	–	–	–
	20	3100	180 (1593)	–	0.60 (0.20)	0.84 (0.29)	2.48 (0.85)	–	–	–
	28	3100	180 (1593)	–	0.49 (0.17)	0.73 (0.25)	2.36 (0.81)	–	–	–
	40	3100	180 (1593)	–	0.43 (0.15)	0.67 (0.23)	2.31 (0.79)	–	–	–
	50	3500	175 (1549)	–	0.43 (0.15)	0.66 (0.23)	2.30 (0.79)	–	–	–
SP 140S-MF2	16	2900	360 (3186)	–	–	2.79 (0.96)	3.61 (1.23)	9.60 (3.28)	–	–
	20	2900	360 (3186)	–	–	2.26 (0.77)	3.08 (1.05)	9.07 (3.1)	–	–
	28	2900	360 (3186)	–	–	1.84 (0.63)	2.66 (0.91)	8.65 (2.96)	–	–
	40	2900	360 (3186)	–	–	1.58 (0.54)	2.39 (0.82)	8.39 (2.87)	–	–
	50	3200	360 (3186)	–	–	1.57 (0.54)	2.38 (0.81)	8.37 (2.86)	–	–
SP 180S-MF2	16	2700	750 (6638)	–	–	–	10.2 (3.48)	15.8 (5.41)	14.4 (4.91)	–
	20	2700	750 (6638)	–	–	–	8.48 (2.9)	14.1 (4.82)	12.1 (4.12)	–
	28	2700	750 (6638)	–	–	–	6.90 (2.36)	12.5 (4.27)	11 (3.76)	–
	40	2700	750 (6638)	–	–	–	6.06 (0.91)	11.6 (3.96)	10.2 (3.48)	–
	50	2900	750 (6638)	–	–	–	5.98 (2.04)	11.6 (3.96)	10.1 (3.45)	–
SP 210-MF2	16	2100	1000 (8851)	–	–	–	–	36.3 (12.4)	37.4 (12.8)	–
	20	2100	1000 (8851)	–	–	–	–	34.5 (11.8)	35.6 (12.2)	–
	28	2100	1000 (8851)	–	–	–	–	32.3 (11.0)	33.4 (11.4)	–
	40	2300	1000 (8851)	–	–	–	–	23.1 (7.89)	24.3 (8.3)	–
	50	2300	1000 (8851)	–	–	–	–	21.9 (7.48)	23 (7.86)	–
SP 240-MF2	16	1900	1700 (15046)	–	–	–	–	47.3 (16.2)	48.4 (16.5)	53 (18.1)
	20	1900	1700 (15046)	–	–	–	–	43.1 (14.7)	44.2 (15.1)	48.8 (16.7)
	28	1900	1700 (15046)	–	–	–	–	37.5 (12.8)	38.6 (13.2)	43.2 (14.8)
	40	2100	1700 (15046)	–	–	–	–	32.4 (11.1)	33.6 (11.5)	38.1 (13)
	50	2100	1700 (15046)	–	–	–	–	29.5 (10.1)	30.6 (10.5)	35.1 (12)

¹⁾ The limit values in the table apply for S1 continuous duty (ON time > 60% or > 20 min) for a maximum gearbox temperature of 90 °C (194 °F).

Synchronous motors

Gearboxes

Series SP+ planetary gearbox for 1FK7 motors

Overview

1FK7 motors can be combined with planetary gearboxes to form compact coaxial drive units. The gearboxes are flanged directly to the drive end of the motors.

When selecting the gearboxes, ensure that the permissible speed of the gearbox is not exceeded by the maximum speed of the motor. In the case of high operating frequencies, allowance must be made for the factor f_2 (see Configuration Manual for synchronous motors). The frictional losses of the gearbox must always be taken into account in planning.

The gearboxes are only available in non-balanced design.

Benefits

- High efficiency
Single-stage: > 97%
Two-stage: > 94%
- Minimum torsional backlash
Single-stage: ≤ 4 arcmin,
two-stage: ≤ 6 arcmin
- Power transmission from the central sun wheel via planet wheels
- No shaft deflections in the planet wheel set due to symmetrical force distribution
- Very low moment of inertia and hence short acceleration times of the motors
- Output shaft bearings dimensioned for high lateral and axial loads with preloaded tapered-roller bearings
- The gearboxes are connected to the motor shaft via an integrated clamping hub. A plain motor shaft extension is necessary for this purpose. Shaft and flange accuracy tolerance N in accordance with DIN 42955 and vibration magnitude grade A in accordance with EN 60034-14 are sufficient. The motor flange is adapted by means of adapter plates.
- Output shaft of gearbox exactly coaxial with the motor
- The gearboxes are enclosed (seal between gearbox and motor) and filled with oil at the factory. They are lubricated and sealed for their service life. Gearboxes of frame sizes SP 060S to SP 180S are suitable for all mounting positions. The oil filling quantity for gearboxes of frame sizes SP 210 and SP 240 depends on the mounting position. The mounting position has to be specified when ordering.
- Degree of protection of gearbox: IP65 (IP64 for frame sizes SP 210/SP 240)
- Small dimensions
- Low weight



Synchronous motor with mounted planetary gearbox series SP+

Integration

1FK702 to 1FK710 motors can be supplied ex works (Siemens AG) complete with flange-mounted planetary gearbox.

The gearboxes assigned to the individual motors and gear ratios i available for these motor/gearbox combinations are listed in the selection table. When making a selection, account must be taken of the maximum permissible input speed of the gearbox (this is the same as the maximum motor speed).

The motor/gearbox combinations listed in the selection tables are mainly intended for cycle operation S3-60% (ON time ≤ 60% and ≤ 20 min). Reduced maximum motor speeds and output torques apply for use in S1 continuous duty (ON time > 60% or > 20 min). The gearbox temperature must not exceed 90 °C (194 °F).

Follow the instructions contained in the Configuration Manual for synchronous motors when assigning gearboxes to the motor.

1FK7 motors must be designed with plain motor shaft extension/shaft and flange accuracy tolerance N, degree of protection IP65 and anthracite paint finish for mounting onto the gearbox.

Synchronous motors

Gearboxes

Series SP+ planetary gearbox, single-stage for 1FK7 motors

Selection and Ordering Data

Motor Natural cooling	Planetary gearbox Single-stage			Available gear ratios $i =$				Motor speed, max. S3-60%	Output torque, max. S3-60%	Radial load on output shaft, max. ¹⁾	Axial load on output shaft, max. ¹⁾
				4	5	7	10				
Type	Type	Tor-sional backlash arcmin	Weight of gearbox, approx. kg (lb)					n_{G1} (n_1) rpm	M_{G2} (T_{2B}) Nm (lb _f -ft)	F_r (F_{2Rmax}) N (lb _f)	F_a (F_{2Amax}) N (lb _f)
1FK7022	SP 060S-MF1	≤ 4	1.9 (4.19)	✓	✓	✓	✓	6000	40 (29.5) (32 (23.6) for $i = 10$)	2700 (607)	2400 (540)
1FK7032				✓	✓	✓	✓				
1FK7033				✓	✓	✓	✓				
1FK7034				✓	✓	✓	✓				
1FK7040	SP 075S-MF1	≤ 4	3.9 (8.60)	✓	✓	✓	✓	6000	110 (81.1) (90 (66.4) for $i = 10$)	4000 (899)	3350 (753)
1FK7042				✓	✓	✓	✓				
1FK7043				✓	✓	✓	✓				
1FK7044				✓	✓	✓	✓				
1FK7060	SP 100S-MF1	≤ 3	7.7 (17.0)	✓	✓	✓	✓	4500	300 (221) (225 (166) for $i = 10$)	6300 (1416)	5650 (1270)
1FK7061				✓	✓	✓	✓				
1FK7063				✓	✓	✓	✓				
1FK7064				✓	✓	✓	✓				
1FK7080	SP 140S-MF1	≤ 3	17.2 (37.9)	✓	✓	✓	✓	4000	600 (443) (480 (354) for $i = 10$)	9450 (2124)	9870 (2219)
1FK7082				✓	✓	✓	✓				
1FK7083				✓	✓	✓	✓				
1FK7085				✓	✓	✓	✓				
1FK7086				✓	✓	✓	✓				
1FK7100	SP 180S-MF1	≤ 3	34 (75)	✓	✓	✓	✓	3500	1100 (811)	14700 (3305)	14150 (3181)
1FK7101				✓	✓	✓	✓				
1FK7103				✓	✓	✓	✓				
1FK7105				✓	✓	✓	–				
1FK7105	SP 210-MF1 ²⁾	≤ 4	53 (117)	–	–	–	✓	2200	2720 (2006)	18000 (4047)	22500 (5058)

Order codes

- Gearbox shaft with fitted key
- Gearbox shaft without fitted key

J02	J03	J05	J09
J22	J23	J25	J29

Ordering data:

1FK7...-A.71-.. 5-Z

J ■ ■

G
Hwithout holding brake
with holding brake

Order No. of the motor with identifier "-Z" and order code for mounting the planetary gearbox assigned to the motor
Preconditions for mounting planetary gearboxes:
Plain motor shaft extension and IP65 degree of protection, anthracite paint finish

- ✓ Possible
- Not possible

¹⁾ In reference to the output shaft center.

²⁾ For these versions, the quantity of oil in the gearbox depends on the mounting position. In the case of a vertical mounting position, the 12th position in the Order No. should be '9' and a further order code also has to be specified: 1FK7...-A.79-.. 5-Z J.. + M1 ■

G	H	H	G
		Mounting position IM V1	Mounting position IM V3

Technical specifications

Planetary gearbox with 1FK7 motor, natural cooling

Single-stage Type	Gear ratio	Motor speed	Output torque	Moments of inertia of gearbox (referred to the drive)					
				Continuous duty S1 ¹⁾					
				n_{rated1} rpm	M_{rated2} ($T_{2 rated}$) Nm (lb _f -in)	1FK702. J_1 kgcm ² (lb _f -in ²)	1FK703. J_1 kgcm ² (lb _f -in ²)	1FK704. J_1 kgcm ² (lb _f -in ²)	1FK706. J_1 kgcm ² (lb _f -in ²)
SP 060S-MF1	4	3300	26 (230)	0.16 (0.05)	0.24 (0.08)	–	–	–	–
	5	3300	26 (230)	0.13 (0.04)	0.22 (0.08)	–	–	–	–
	7	4000	26 (230)	0.11 (0.04)	0.19 (0.06)	–	–	–	–
	10	4000	17 (151)	0.10 (0.03)	0.18 (0.06)	–	–	–	–
SP 075S-MF1	4	2900	75 (664)	–	–	0.94 (0.32)	–	–	–
	5	2900	75 (664)	–	–	0.83 (0.28)	–	–	–
	7	3100	75 (664)	–	–	0.73 (0.25)	–	–	–
	10	3100	52 (460)	–	–	0.67 (0.23)	–	–	–
SP 100S-MF1	4	2500	180 (1593)	–	–	–	3.65 (1.25)	–	–
	5	2500	175 (1549)	–	–	–	2.99 (1.02)	–	–
	7	2800	170 (1505)	–	–	–	2.81 (0.96)	–	–
	10	2800	120 (1062)	–	–	–	2.58 (0.88)	–	–
SP 140S-MF1	4	2100	360 (3186)	–	–	–	–	14.3 (4.89)	–
	5	2100	360 (3186)	–	–	–	–	13.1 (4.48)	–
	7	2600	360 (3186)	–	–	–	–	12 (4.1)	–
	10	2600	220 (1947)	–	–	–	–	11.4 (3.90)	–
SP 180S-MF1	4	1500	750 (6638)	–	–	–	–	–	45.1 (15.4)
	5	1500	750 (6638)	–	–	–	–	–	36.4 (12.4)
	7	2300	750 (6638)	–	–	–	–	–	28.6 (9.77)
	10	2300	750 (6638)	–	–	–	–	–	24.4 (8.34)
SP 210-MF1	4	1200	1000 (8851)	–	–	–	–	–	75.8 (25.9)
	5	1200	1000 (8851)	–	–	–	–	–	63.5 (21.7)
	7	1700	1000 (8851)	–	–	–	–	–	52.9 (18.1)
	10	1700	1000 (8851)	–	–	–	–	–	47.1 (16.1)

¹⁾ The limit values in the table apply for S1 continuous duty (ON time > 60% or > 20 min) for a maximum gearbox temperature of 90 °C (194 °F).

Synchronous motors

Gearboxes

Series SP+ planetary gearbox, two-stage for 1FK7 motors

Selection and Ordering Data

Motor Natural cooling	Planetary gearbox Two-stage			Available gear ratios $i =$					Motor speed, max. S3-60% n_{G1}	Output torque, max. S3-60% M_{G2}	Radial load on output shaft, max. ¹⁾ F_r	Axial load on output shaft, max. ¹⁾ F_a
				16	20	28	40	50				
Type	Type	Tor-sional back-lash arcmin	Weight of gearbox, approx. kg (lb)									
1FK7022	SP 060S-MF2	≤ 6	2 (4.4)	✓	✓	✓	–	–	6000	40 (29)	2700 (607)	2400 (540)
1FK7032				✓	✓	–	–	–				
1FK7033				✓	✓	–	–	–				
1FK7022	SP 075S-MF2	≤ 6	3.6 (7.9)	–	–	–	✓	✓	6000	110 (81)	4000 (899)	3350 (753)
1FK7032				–	–	✓	✓	✓				
1FK7033				–	–	✓	✓	✓				
1FK7034				✓	✓	✓	–	–				
1FK7040				✓	✓	✓	–	–				
1FK7042				✓	✓	–	–	–				
1FK7043				✓	–	–	–	–				
1FK7034	SP 100S-MF2	≤ 5	7.9 (17.4)	–	–	–	✓	✓	4500	300 (221)	6300 (1416)	5650 (1270)
1FK7040				–	–	–	✓	✓				
1FK7042				–	–	✓	✓	✓				
1FK7043				–	✓	✓	✓	✓				
1FK7044				✓	✓	✓	✓	–				
1FK7060				✓	✓	✓	–	–				
1FK7061				✓	✓	–	–	–				
1FK7044	SP 140S-MF2	≤ 5	17 (17.4)	–	–	–	–	✓	4000	600 (442)	9450 (2124)	9870 (2219)
1FK7060				–	–	–	–	✓				
1FK7061				–	–	✓	✓	✓				
1FK7063				✓	✓	✓	–	–				
1FK7064				✓	✓	✓	–	–				
1FK7080				✓	✓	✓	✓	–				
1FK7082				✓	✓	–	–	–				
1FK7083				✓	✓	–	–	–				

Order codes

- Gearbox shaft with fitted key
- Gearbox shaft without fitted key

J12	J13	J15	J16	J17
J32	J33	J35	J36	J37

Ordering data: **1FK7...-A.71-...5-Z**

J ■ ■

G
H

without holding brake
with holding brake

Order No. of the motor with identifier "**-Z**" and order code for mounting the planetary gearbox assigned to the motor
Preconditions for mounting planetary gearboxes: Plain motor shaft extension and IP65 degree of protection, anthracite paint finish

- ✓ Possible
- Not possible

¹⁾ In reference to the output shaft center.

Synchronous motors

Gearboxes

Series SP+ planetary gearbox, two-stage for 1FK7 motors

Selection and Ordering Data

Motor Natural cooling	Planetary gearbox Two-stage		Available gear ratios $i =$					Motor speed, max. S3-60% n_{G1}	Output torque, max. S3-60% M_{G2}	Radial load on output shaft, max. ¹⁾ F_r	Axial load on output shaft, max. ¹⁾ F_a	
			16	20	28	40	50					
Type	Type	Torsional backlash arcmin	Weight of gearbox, approx. kg (lb)									
1FK7063	SP 180S-MF2	≤ 5	36.4 (80.3)	-	-	-	✓	✓	4000	1100 (811)	14700 (3305)	14150 (3181)
1FK7064				-	-	-	✓	✓				
1FK7080				-	-	-	-	✓				
1FK7083				-	-	✓	-	-				
1FK7085				✓	✓	-	-	-				
1FK7086				✓	✓	-	-	-				
1FK7100				✓	✓	✓	-	-				
1FK7101				✓	✓	-	-	-				
1FK7103	✓	✓	-	-	-							
1FK7083	SP 210-MF2 ²⁾	≤ 6	50 (110)	-	-	-	✓	✓	3500	1900 (1401)	18000 (4047)	22500 (5058)
1FK7085				-	-	✓	✓					
1FK7086				-	-	✓	-					
1FK7100				-	-	-	✓	✓				
1FK7101				-	-	✓	-					
1FK7103				-	✓	-	-					
1FK7105	✓	✓	-	-								
1FK7101	SP 240-MF2 ²⁾	≤ 6	70 (154)	-	-	-	✓	✓	3500	3400 (2508)	27000 (6070)	27800 (6250)
1FK7103				-	-	✓	✓					
1FK7105				-	✓	-	-					

Order codes

- Gearbox shaft with fitted key
- Gearbox shaft without fitted key

J12	J13	J15	J16	J17
J32	J33	J35	J36	J37

Ordering data:

1FK7...-A.71...-5-Z

J ■ ■

G
Hwithout holding brake
with holding brake

Order No. of the motor with identifier "-Z" and order code for mounting the planetary gearbox assigned to the motor
Preconditions for mounting planetary gearboxes: Plain motor shaft extension and IP65 degree of protection, anthracite paint finish

¹⁾ In reference to the output shaft center.

²⁾ For these versions, the quantity of oil in the gearbox depends on the mounting position. In the case of a vertical mounting position, the 12th position in the Order No. should be '9' and a further order code also has to be specified: 1FK7...-A.79...-5-Z J.. + M1 ■

G
HH Mounting position IM V1
G Mounting position IM V3

Synchronous motors

Gearboxes

Series SP+ planetary gearbox, two-stage for 1FK7 motors

Technical specifications

Planetary gearbox with 1FK7 motor											
Two-stage Type	Gear ratio	Motor speed	Output torque	Moments of inertia of gearbox (referred to the drive)							
				Continuous duty S1 ¹⁾		1FK702.	1FK703.	1FK704.	1FK706.	1FK708.	1FK710.
				$n_{rated\ 1}$	$M_{rated\ 2}$ ($T_2\ rated$)	J_1	J_1	J_1	J_1	J_1	J_1
		rpm	Nm (lb _f -in)	kgcm ² (lb _f -in ²)	kgcm ² (lb _f -in ²)	kgcm ² (lb _f -in ²)	kgcm ² (lb _f -in ²)	kgcm ² (lb _f -in ²)	kgcm ² (lb _f -in ²)		
SP 060S-MF2	16	4400	26 (230)	0.08 (0.03)	0.18 (0.06)	–	–	–	–		
	20	4400	26 (230)	0.07 (0.03)	0.17 (0.06)	–	–	–	–		
	28	4400	26 (230)	0.06 (0.02)	0.16 (0.05)	–	–	–	–		
	40	4400	26 (230)	0.06 (0.02)	0.16 (0.05)	–	–	–	–		
	50	4800	26 (230)	0.06 (0.02)	0.16 (0.05)	–	–	–	–		
SP 075S-MF2	16	3500	75 (664)	0.17 (0.06)	0.25 (0.08)	0.68 (0.23)	–	–	–		
	20	3500	75 (664)	0.14 (0.05)	0.22 (0.08)	0.65 (0.22)	–	–	–		
	28	3500	75 (664)	0.11 (0.04)	0.19 (0.06)	0.62 (0.21)	–	–	–		
	40	3500	75 (664)	0.10 (0.03)	0.18 (0.06)	0.61 (0.21)	–	–	–		
	50	3800	75 (664)	0.10 (0.03)	0.18 (0.06)	0.61 (0.21)	–	–	–		
SP 100S-MF2	16	3100	180 (1593)	–	–	0.96 (0.33)	2.60 (0.89)	–	–		
	20	3100	180 (1593)	–	–	0.84 (0.29)	2.48 (0.85)	–	–		
	28	3100	180 (1593)	–	–	0.73 (0.25)	2.36 (0.81)	–	–		
	40	3100	180 (1593)	–	–	0.67 (0.23)	2.31 (0.79)	–	–		
	50	3500	175 (1549)	–	–	0.66 (0.23)	2.30 (0.79)	–	–		
SP 140S-MF2	16	2900	360 (3186)	–	–	2.79 (0.96)	3.61 (1.23)	9.60 (3.28)	–		
	20	2900	360 (3186)	–	–	2.26 (0.77)	3.08 (1.05)	9.07 (3.1)	–		
	28	2900	360 (3186)	–	–	1.84 (0.63)	2.66 (0.91)	8.65 (2.96)	–		
	40	2900	360 (3186)	–	–	1.58 (0.54)	2.39 (0.82)	8.39 (2.87)	–		
	50	3200	360 (3186)	–	–	1.57 (0.54)	2.38 (0.81)	8.37 (2.86)	–		
SP 180S-MF2	16	2700	750 (6638)	–	–	–	10.2 (3.48)	15.8 (5.41)	14.4 (4.91)		
	20	2700	750 (6638)	–	–	–	8.48 (2.9)	14.1 (4.82)	12.1 (4.12)		
	28	2700	750 (6638)	–	–	–	6.90 (2.36)	12.5 (4.27)	11 (3.76)		
	40	2700	750 (6638)	–	–	–	6.06 (0.91)	11.6 (3.96)	10.2 (3.48)		
	50	2900	750 (6638)	–	–	–	5.98 (2.04)	11.6 (3.96)	10.1 (3.45)		
SP 210-MF2	16	2100	1000 (8851)	–	–	–	–	36.3 (12.4)	37.4 (12.8)		
	20	2100	1000 (8851)	–	–	–	–	34.5 (11.8)	35.6 (12.2)		
	28	2100	1000 (8851)	–	–	–	–	32.3 (11.0)	33.4 (11.4)		
	40	2300	1000 (8851)	–	–	–	–	23.1 (7.89)	24.3 (8.3)		
	50	2300	1000 (8851)	–	–	–	–	21.9 (7.48)	23 (7.86)		
SP 240-MF2	16	1900	1700 (15046)	–	–	–	–	–	48.4 (16.5)		
	20	1900	1700 (15046)	–	–	–	–	–	44.2 (15.1)		
	28	1900	1700 (15046)	–	–	–	–	–	38.6 (13.2)		
	40	2100	1700 (15046)	–	–	–	–	–	33.6 (11.5)		
	50	2100	1700 (15046)	–	–	–	–	–	30.6 (10.5)		

¹⁾ The limit values in the table apply for S1 continuous duty (ON time > 60% or > 20 min) for a maximum gearbox temperature of 90 °C (194 °F).

Synchronous motors

Gearboxes

Series LP+ planetary gearbox for 1FK7 motors

Overview

1FK7 motors can easily be combined with planetary gearboxes to form compact coaxial drive units. The gearboxes are flanged directly to the drive end of the motors.

When selecting the gearboxes, ensure that the permissible speed of the gearbox is not exceeded by the maximum speed of the motor. In the case of high operating frequencies, allowance must be made for the factor f_2 (see Configuration Manual for synchronous motors). The frictional losses of the gearbox must always be taken into account in planning.

The gearboxes are only available in non-balanced design and with fitted key.

Benefits

- High efficiency, single-stage: > 97%
- Torsional backlash, single-stage: ≤ 12 arcmin
- Power transmission from the central sun wheel via planet wheels
- No shaft deflections in the planet wheel set due to symmetrical force distribution
- The gearboxes are connected to the motor shaft via an integrated clamping hub. A plain motor shaft extension is necessary for this purpose. Shaft and flange accuracy tolerance N in accordance with DIN 42955 and vibration magnitude grade A in accordance with EN 60034-14 are sufficient. The motor flange is adapted by means of adapter plates.
- Output shaft of gearbox exactly coaxial with the motor
- The gearboxes are enclosed (seal between gearbox and motor) and filled with grease at the factory. They are lubricated and sealed for their service life
- Degree of protection of gearbox: IP64
- Small dimensions
- Low weight



Synchronous motor with mounted planetary gearbox series LP+

Integration

1FK702 to 1FK710 motors can be supplied ex works (Siemens AG) complete with flange-mounted planetary gearbox.

The gearboxes assigned to the individual motors and gear ratios i available for these motor/gearbox combinations are listed in the selection table. When making a selection, account must be taken of the maximum permissible input speed of the gearbox (this is the same as the maximum motor speed).

The motor/gearbox combinations listed in the selection table are mainly intended for cycle operation S3-60% (ON time $\leq 60\%$ and ≤ 20 min). Reduced maximum motor speeds and output torques apply for use in S1 continuous duty (ON time > 60% or > 20 min). The gearbox temperature must not exceed 90 °C (194 °F).

Follow the instructions contained in the Configuration Manual for synchronous motors when assigning gearboxes to the motor.

1FK7 motors must be designed with plain motor shaft extension/shaft and flange accuracy tolerance N, degree of protection IP64 and anthracite paint finish for mounting onto the gearbox.

Synchronous motors

Gearboxes

Series LP+ planetary gearbox, single-stage for 1FK7 motors

Selection and Ordering Data

Motor Natural cooling	Planetary gearbox Single-stage Torsional backlash ≤ 12 arcmin		Available gear ratios $i =$		Input speed, max. S3-60%	Output torque, max. S3-60%		Output shaft radial force, max. ¹⁾	Moment of inertia Gearbox
	Type	Weight of gearbox, approx. kg (lb)	5	10		n_{G1} rpm	M_{G2} at $i = 5$ Nm (lb _f ft)		
1FK7022	LP 050-M01	0.75 (1.7)	✓	–	8000	12 (9)	11 (8)	650 (146)	0.055 (0.05)
1FK7022	LP 070-M01	2 (4.4)	–	✓	6000	35 (26)	32 (24)	1450 (326)	0.28 (0.25)
1FK7032			✓	✓					
1FK7033			✓	✓					
1FK7034			✓	✓					
1FK7040	LP 090-M01	4 (8.8)	✓	✓	6000	90 (66)	80 (59)	2400 (540)	1.77 (1.57)
1FK7042	LP 120-M01	8.6 (19)	✓	✓	4800	220 (162)	200 (148)	4600 (1034)	5.42 (4.80)
1FK7043			✓	✓					
1FK7044			✓	✓					
1FK7060			✓	✓					
1FK7061	LP 155-M01	17 (38)	✓	✓	3600	450 (332)	350 (258)	7500 (1686)	25.7 (22.8)
1FK7063			✓	✓					
1FK7064			✓	–					
1FK7080			✓	✓					
1FK7083	LP 155-M01	17 (38)	✓	✓	3600	450 (332)	350 (258)	7500 (1686)	25.7 (22.8)
1FK7085			✓	–					
1FK7086			✓	–					
1FK7100			✓	✓					
1FK7101	LP 155-M01	17 (38)	✓	–	3600	450 (332)	350 (258)	7500 (1686)	25.7 (22.8)
1FK7103			✓	–					
1FK7105			✓	–					
1FK7105			✓	–					

Order code

- Gearbox shaft with fitted key

V40 V42

Ordering data:

1FK7...-A.71-...3-Z

V ■ ■

G

H

without holding brake
with holding brake

Order No. of the motor with identifier "-Z" and

order code for mounting the planetary gearbox assigned to the motor

Preconditions for mounting planetary gearboxes:

Plain motor shaft extension and IP64 degree of protection, anthracite paint finish

Continuous duty S1

Continuous duty is permissible at the rated speed and rated torque. The gearbox temperature may not exceed 90 °C (194 °F).

Planetary gearbox Single-stage Torsional backlash ≤ 12 arcmin	Rated input speed	Rated output torque	
Type	n_{rated1} rpm	M_{rated2} at $i = 5$ Nm (lb _f ft)	M_{rated2} at $i = 10$ Nm (lb _f ft)
LP 050-M01	4000	5.7 (4.2)	–
LP 070-M01	3700	18 (13)	16.5 (12.2)
LP 090-M01	3400	45 (33)	40 (30)
LP 120-M01	2600	110 (81)	100 (74)
LP 155-M01	2000	320 (236)	190 (140)

✓ Possible

– Not possible

¹⁾ In reference to the output shaft center at 100 rpm.

Synchronous motors

Geared motors

1FK7-DYA compact geared motors

Overview



The 1FK7-DYA compact geared motor combines electrical and mechanical components in the smallest space possible. This mechatronic unit consists of a permanent-magnet-excited synchronous motor and a directly mounted single-stage planetary gearbox.

The 1FK7-DYA compact geared motors with degree of protection IP64 are designed for operation without external cooling as the heat is dissipated over the motor surface. The integrated planetary gearboxes have high maximum torques and permit high radial and axial forces at the shaft extension.

1FK7-DYA compact geared motors can be combined with the SINAMICS S120 drive system to create a powerful system with high functionality. The integrated encoder system for speed and position control can be selected depending on the application.

Benefits

- Space-saving installation due to the high power density of the motor and integration of the planetary gearbox directly into the motor end shield. This greatly simplifies gear mounting on the machine and reduces logistics to a minimum.
- Highly dynamic due to lower motor moment of inertia; this means shorter cycle times.
- Maintenance-free
- Suitable for S1 continuous duty
- High positioning accuracy thanks to low mechanical torsional backlash of <8 arcmin
- Mechanical compatibility with regard to IM B14 flange and shaft extension for the LP+ planetary gearbox

Application

In general mechanical engineering, wherever coaxial drive units are used, such as in

- Packaging machinery
- Wood, glass and ceramic working machines
- Plastic injection molding and foil stretching machines
- Handling systems
- Machine tools
- All kinds of auxiliary axes

Technical specifications

Type of motor	Permanent-magnet-excited synchronous motor
Magnet material	Rare-earth magnet material
Insulation of the stator winding in accordance with EN 60034-1 (IEC 60034-1)	Temperature class 155 (F) for a winding temperature rise of $\Delta T = 100$ K at an ambient temperature of 40 °C (104 °F)
Cooling	Natural cooling
Temperature monitoring	KTY 84 temperature sensor in stator winding
Type in accordance with EN 60034-7 (IEC 60034-7)	IM B5 (IM V1, IM V3) IM B14
Degree of protection in accordance with EN 60034-5 (IEC 60034-5)	IP64
Shaft extension on the drive end in accordance with DIN 748-3 (IEC 60072-1)	With fitted key
Shaft and flange accuracy¹⁾ in accordance with DIN 42955 (IEC 60072-1)	Tolerance N
Vibration magnitude in accordance with EN 60034-14 (IEC 60034-14)	Grade A is observed up to rated speed
Sound pressure level in accordance with EN ISO 1680, max.	<ul style="list-style-type: none"> • 1FK703 72 dB (A) • 1FK704 75 dB (A) • 1FK706 80 dB (A) • 1FK708 82 dB (A)
Encoder systems, built-in for motors without DRIVE-CLiQ interface	<ul style="list-style-type: none"> • Incremental encoder sin/cos 1 V_{pp} 2048 S/R • Absolute encoder multi-turn (traversing range 4096 revolutions) with EnDat interface 1FK704 ... 1FK708: 2048 S/R 1FK703: 512 S/R 1FK704 ... 1FK708: 32 S/R 1FK703: 16 S/R • Multi-pole resolver (number of poles corresponds to number of pole pairs of the motor) • 2-pole resolver
Encoder systems, built-in for motors with DRIVE-CLiQ interface	<ul style="list-style-type: none"> • 22 bit incremental encoder (2048 S/R internal) • Absolute encoder single-turn +12 bit multi-turn (traversing range 4096 revolutions) 1FK704 ... 1FK708: 22 bit single-turn (2048 S/R internal) 1FK703: 20 bit single-turn (512 S/R internal) 1FK704 ... 1FK708: 16 bit single-turn (32 S/R internal) 1FK703: 15 bit single-turn (16 S/R internal) • 15 bit resolver • 14 bit resolver
Connection	Connectors for signals and power can be rotated (270°)
Paint finish	Anthracite RAL 7016
2nd rating plate 3rd rating plate	Attached in the NDE cover Enclosed separately
Options	Built-in holding brake

S/R = signals/revolution

¹⁾ Shaft extension run-out, concentricity of spigot and shaft and perpendicularity of mounting face of flange to shaft.

Synchronous motors

Geared motors

1FK7-DYA compact geared motors

Selection and Ordering Data

Rated speed	Rated power	Maximum speed	Maximum torque	Static torque	Rated torque	Available gear ratio	Compact geared motor 1FK7-DYA Natural cooling		Number of pole pairs	Rotor moment of inertia ²⁾ (without brake) (with brake)	
$n_{2 \text{ rated}}$	P_2	$n_{2 \text{ max}}$	$M_{2 \text{ max}}$	M_{20}	$M_{2 \text{ rated}}^{1)}$	i	Order No.	Order code	J	J	
rpm	kW (HP)	rpm	Nm (lb _f -in)	Nm (lb _f -in)	Nm (lb _f -in)				10^{-4} kgm^2 ($10^{-3} \times$ lb _f -in-s ²)	10^{-4} kgm^2 ($10^{-3} \times$ lb _f -in-s ²)	
370	0.37 (0.50)	600	32 (283)	11 (97)	9.5 (84.1)	10	1FK7032-5AK71-1 ■ ■ ■ 3-Z A03		3	0.75 (0.66)	0.83 (0.73)
740	0.5 (0.67)	1200	32 (283)	7.5 (66)	6.5 (57.5)	5	1FK7034-5AK71-1 ■ ■ ■ 3-Z A00		3	1.04 (0.92)	1.12 (0.99)
340	0.45 (0.60)	600	49 (434)	15 (133)	12.5 (111)	10	1FK7040-5AK71-1 ■ ■ ■ 3-Z A13		4	2.3 (2.04)	3 (2.66)
680	0.71 (0.95)	1200	51 (451)	13 (115)	10 (88.5)	5	1FK7042-5AK71-1 ■ ■ ■ 3-Z A10		4	3.6 (3.19)	4.3 (3.81)
260	1.25 (1.68)	480	175 (1549)	57 (505)	46 (407)	10	1FK7060-5AH71-1 ■ ■ ■ 3-Z A73		4	10.3 (9.12)	12.5 (11.1)
520	1.74 (2.33)	960	170 (1505)	51 (451)	32 (283)	5	1FK7063-5AH71-1 ■ ■ ■ 3-Z A70		4	17.4 (15.4)	19.6 (17.3)
200	1.47 (1.97)	360	242 (2142)	76 (673)	70 (620)	10	1FK7080-5AH71-1 ■ ■ ■ 3-Z A83		4	28.7 (25.4)	31.8 (28.1)
400	1.88 (2.52)	720	233 (2062)	68 (602)	45 (398)	5	1FK7083-5AH71-1 ■ ■ ■ 3-Z A80		4	41 (36.3)	49.6 (43.9)
Encoder systems for motors without DRIVE-CLiQ interface:		Incremental encoder sin/cos 1 V _{pp} , 2048 S/R Absolute encoder EnDat 2048 S/R ¹⁾ (not for 1FK703) Absolute encoder EnDat 512 S/R ¹⁾ (only for 1FK703) Absolute encoder EnDat 32 S/R ¹⁾ (not for 1FK703) Absolute encoder EnDat 16 S/R ¹⁾ (only for 1FK703) Multi-pole resolver 2-pole resolver					A E H G J S T				
Encoder systems for motors with DRIVE-CLiQ interface:		Incremental encoder 22 bit Absolute encoder, 22 bit single-turn +12 bit multi-turn ¹⁾ (not for 1FK703) Absolute encoder, 20 bit single-turn +12 bit multi-turn ¹⁾ (only for 1FK703) Absolute encoder, 16 bit single-turn +12 bit multi-turn ¹⁾ (not for 1FK703) Absolute encoder, 15 bit single-turn +12 bit multi-turn ¹⁾ (only for 1FK703) 14 bit resolver 15 bit resolver					D F L K V U P				
Shaft extension: Fitted key and keyway Fitted key and keyway		Shaft and flange accuracy: Tolerance N Tolerance N		Holding brake: Without With		U V					
Degree of protection:		IP64, anthracite finish RAL 7016									3

Synchronous motors

Geared motors

1FK7-DYA compact geared motors

Selection and Ordering Data

Motor type (continued)	Weight		Static current	Maxi- mum current	SINAMICS S120 Motor Module		Power cable with complete shield		
	(without brake)	(with brake)			Rated output current ⁴⁾	Booksiz e format	Motor terminal (and brake terminal) via power connector		
	<i>m</i>	<i>m</i>	I_0 at M_0 $\Delta T=100$ K	I_{max}	I_{rated}	Order No.	Power con- nector	Motor cable cross- section ³⁾	Order No. Pre-assembled cable
	kg (lb)	kg (lb)	A	A	A		Size	mm ²	
1FK7032-5AK71-...	4.11 (9.1)	4.47 (9.9)	1.7	5	3	6SL312 - - TE13 - 0AA3	1	4 x 1.5	6FX 002-5 S01-....
1FK7034-5AK71-...	5.01 (11.0)	5.37 (11.8)	1.9	7.9	3	6SL312 - - TE13 - 0AA3	1	4 x 1.5	6FX 002-5 S01-....
1FK7040-5AK71-...	6.6 (14.6)	7.61 (16.8)	2.3	7.4	3	6SL312 - - TE13 - 0AA3	1	4 x 1.5	6FX 002-5 S01-....
1FK7042-5AK71-...	7.91 (17.4)	8.62 (19.0)	4.4	14.9	5	6SL312 - - TE15 - 0AA3	1	4 x 1.5	6FX 002-5 S01-....
1FK7060-5AH71-...	13.9 (30.7)	15 (33.1)	6.2	19	9	6SL312 - - TE21 - 0AA3	1	4 x 1.5	6FX 002-5 S01-....
1FK7063-5AH71-...	17.6 (38.8)	19 (41.9)	12	41	18	6SL312 - - TE21-8AA3	1	4 x 1.5	6FX 002-5 S01-....
1FK7080-5AH71-...	23.4 (51.6)	24.6 (54.2)	7.4	24	9	6SL312 - - TE21 - 0AA3	1	4 x 1.5	6FX 002-5 S01-....
1FK7083-5AH71-...	28.6 (63.1)	31.2 (68.8)	15	48	18	6SL312 - - TE21-8AA3	1	4 x 1.5	6FX 002-5 S01-....

Cooling:

Internal air cooling
External air cooling

0
1

Motor Module:

Single Motor Module
Double Motor Module

1
2

Type of ower cable:

MOTION-CONNECT 800
MOTION-CONNECT 500

8
5

Without brake cores
With brake cores

C
D

For length code as well as power and signal cables, see Connection system MOTION-CONNECT.

....

¹⁾ If the absolute encoder is used, $M_{2 rated}$ is reduced by 10%.

²⁾ In reference to the motor shaft.

³⁾ The current carrying capacity of the power cables complies with IEC 60204-1 for installation type C under continuous operating conditions at an ambient air temperature of 40 °C (104 °F), designed for I_0 (100 K), PVC/PUR-insulated cable.

⁴⁾ With default setting of the pulse frequency.

Synchronous motors

Linear motors for SINAMICS S120

1FN3 linear motors Water cooling

Overview



In combination with the SINAMICS S120 drive system, 1FN3 linear motors provide an optimally tuned linear direct drive system for the requirements of modern mechanical engineering.

The motors comprise a primary section and a secondary section with magnets made of rare-earth material. The primary section has fixed dimensions, while the secondary section is made up of individual elements (segments) to suit the required traversing range. Through parallel operation of the motors, feedrate force and length can be scaled beyond the available spectrum.

Benefits

- Outstanding dynamic response and very high traversing velocity
- Excellent precision
- Easy installation
- Drive components are free of wear thanks to contactless drive force transmission

The main advantage of linear direct drive technology is the extensive avoidance of the effects of elasticity, play, and friction, as well as natural oscillation in the drive train. This results in a higher dynamic response and increased precision. If suitable measuring systems are used and the temperature conditions are appropriate, the motors can be positioned in the nanometer range.

Design

The simple mechanical construction without transmission elements, such as ballscrew, coupling or belt, enhances the reliability of the drive components.

Heat loss occurs almost exclusively in the primary section and is dissipated via an integrated liquid cooling system. The optional Thermo-Sandwich dual-circuit cooling system permits both a thermal decoupling of the motor from the machine, and also a low-priced cooling design.

The stainless metal encapsulation of the primary section ensures the high mechanical ruggedness and resistance to soiling required for use in machine tools, as well as high resistance to corrosive liquids. In addition, the motor places minimal demands on the preparation of mounting surfaces thanks to the large air gap. The mounting tolerances for the air gap are ± 0.3 mm (0.012 in).

Design variants

1FN linear motors are available as single-sided or double-sided motors.

- Single-sided motors
The single-sided version consists of a primary section that is mounted parallel to the associated secondary section.
- Double-sided motors
The special secondary section of the double-sided version lies between two primary sections (one primary section with standard winding and one with complementary winding). The design as a double-sided motor is particularly suitable for applications with movable secondary section and small traversing paths with fast acceleration (e.g. non-circular machining).

Application

Version for peak load

Used in machine axes that are temporarily accelerated (e.g. S3 duty) or when large forces are required for a short time.

Typical applications:

- High-dynamic and flexible machine tool construction
- Laser machining
- Handling

Version for continuous load

Used in machine axes with constant acceleration changes (e.g. S1 duty), with high process/weight forces or for operation without water cooling.

Typical applications:

- Grinding
- Non-circular machining (e.g. oscillating applications)
- Z-axes without weight compensation, quills
- Handling, Cartesian robots

Synchronous motors

Linear motors for SINAMICS S120

1FN3 linear motors
Water cooling

Technical specifications

Product name	1FN3 linear motors	
	Peak load	Continuous load
Type of motor	Permanent-magnet-excited synchronous linear motor	
Magnet material	Rare-earth magnet material	
Insulation of stator winding in accordance with EN (IEC) 60034-1	Temperature class 155 (F) for a winding temperature of 120 °C (248 °F)	
Overload ratio ($F_{MAX}:F_{rated}$) up to max.	2.75	1.7
Degree of protection in accordance with EN 60034-5 (IEC 60034-5)	IP65	
Type of cooling	Water cooling	
Water cooler connections	G 1/8 internal thread on all primary and secondary section coolers	
Temperature influence on surrounding construction with precision cooling, max.	+4 K	
Coolant inlet temperature, permissible	35 °C (95 °F) (avoid condensation) > 35 °C (95 °F) on reduction of rated motor power	
Temperature monitoring integrated in the primary section winding	2 monitoring circuits (Temp-S with PTC thermistor) and Temp-F with KTY 84 temperature sensor (for 1FN3050, Temp-S only) Evaluation via Sensor Module External SME120/SME125 ¹⁾	
Available configurations	Different gradations due to modular construction	
Secondary section cover	Exchangeable through all segments or segment by segment	
2nd rating plate	Enclosed separately	
Recommended measuring systems	See Overview of measuring systems	
Type of connection	Prepared for separate connection of the power and signal cable	

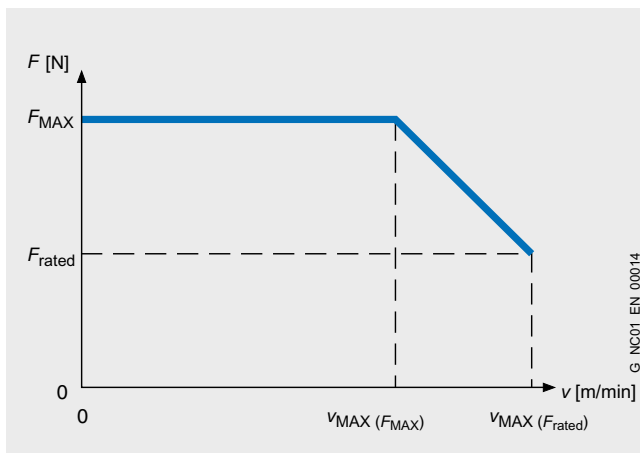

The 1FN3 linear motors have an overload range available for acceleration processes. The maximum force F_{MAX} can only be utilized up to a maximum velocity $v_{MAX}(F_{MAX})$; up to velocity $v_{MAX}(F_{rated})$, only the feedrate force F_{rated} is available.

¹⁾ For SME120/SME125, see SINAMICS S120 drive system.

Synchronous motors

Linear motors for SINAMICS S120

1FN3 standard type linear motors Version for peak load – water cooling

Selection and Ordering Data

Feedrate force		Maximum velocity ³⁾		1FN3 linear motors – Version for peak load Water cooling		Weight, approx.	
F_{rated} ¹⁾²⁾	F_{MAX}	v_{MAX} at F_{MAX}	v_{MAX} at F_{rated}	Primary section	Secondary section	Primary section without/with precision cooling	Secondary section without/with heatsink profiles
N (lb _f)	N (lb _f)	m/min (ft/min)	m/min (ft/min)	Order No.	Order No.	kg (lb)	kg (lb)
200 (45)	550 (124)	146 (479)	373 (1224)	1FN3050-2WC00-0EA1	1FN3050-4SA00-0AA0	2.4/2.9 (5.3/6.4)	0.4/0.5 (0.9/1.1)
200 (45)	550 (124)	146 (479)	373 (1224)	1FN3050-2WC00-0FA1		2.4/2.9 (5.3/6.4)	0.4/0.5 (0.9/1.1)
200 (45)	490 (110)	138 (453)	322 (1056)	1FN3100-1WC00-0BA1	1FN3100-4SA00-0AA0	2.2/- (4.9/-) ⁴⁾	0.7/0.8 (1.5/1.8)
450 (101)	1100 (247)	131 (430)	297 (974)	1FN3100-2WC00-0BA1		3.8/4.4 (8.4/9.7)	
450 (101)	1100 (247)	237 (778)	497 (1631)	1FN3100-2WE00-0BA1		3.8/4.4 (8.4/9.7)	
675 (152)	1650 (371)	120 (394)	277 (909)	1FN3100-3WC00-0BA1		5.4/6.2 (11.9/13.7)	
675 (152)	1650 (371)	237 (778)	497 (1631)	1FN3100-3WE00-0BA1		5.4/6.2 (11.9/13.7)	
900 (202)	2200 (495)	131 (430)	297 (974)	1FN3100-4WC00-0BA1		7.4/8.5 (16.3/18.7)	
900 (202)	2200 (495)	237 (778)	497 (1631)	1FN3100-4WE00-0BA1		7.4/8.5 (16.3/18.7)	
1125 (253)	2750 (618)	109 (358)	255 (837)	1FN3100-5WC00-0BA1		9.1/10.4 (20.1/22.9)	
340 (76)	820 (184)	126 (413)	282 (925)	1FN3150-1WC00-0BA1	1FN3150-4SA00-0AA0	3.0/- (6.6/-) ⁴⁾	1.2/1.3 (2.7/2.9)
675 (152)	1650 (371)	126 (413)	282 (925)	1FN3150-2WC00-0BA1		5.3/6 (11.7/13.2)	
1015 (228)	2470 (555)	126 (413)	282 (925)	1FN3150-3WC00-0BA1		7.8/8.7 (17.2/19.2)	
1350 (304)	3300 (742)	126 (413)	282 (925)	1FN3150-4WC00-0BA1		10.2/11.4 (22.5/25.1)	
1690 (380)	4120 (926)	126 (413)	282 (925)	1FN3150-5WC00-0BA1		12.8/14.2 (28.2/31.3)	
615 (138)	1720 (387)	128 (420)	309 (1014)	1FN3300-1WC00-0BA1	1FN3300-4SA00-0AA0	6.2/- (13.7/-) ⁴⁾	2.4/2.6 (5.3/5.7)
1225 (275)	3450 (776)	63 (207)	176 (577)	1FN3300-2WB00-0BA1		11.4/12.4 (25.1/27.3)	
1225 (275)	3450 (776)	125 (410)	297 (974)	1FN3300-2WC00-0BA1		11.4/12.4 (25.1/27.3)	
1225 (275)	3450 (776)	369 (1211)	805 (2641)	1FN3300-2WG00-0BA1		11.4/12.4 (25.1/27.3)	
1840 (414)	5170 (1162)	125 (410)	297 (974)	1FN3300-3WC00-0BA1		17.0/18.4 (37.5/40.6)	
1840 (414)	5170 (1162)	383 (1257)	836 (2743)	1FN3300-3WG00-0BA1		17.0/18.4 (37.5/40.6)	
2450 (551)	6900 (1551)	63 (207)	176 (577)	1FN3300-4WB00-0BA1		22.2/24 (48.9/52.9)	
2450 (551)	6900 (1551)	125 (410)	297 (974)	1FN3300-4WC00-0BA1		22.2/24 (48.9/52.9)	

Type of connection:

Frame sizes 1FN3100 to 1FN3900

B

Connection cover prepared for separate power and signal cables

Frame size 1FN3050

E

Permanently connected power and signal cables with open core ends
Length: 2 m (6.56 ft)

Frame size 1FN3050

F

Permanently connected power and signal cables pre-assembled,
with connectors
Length: 0.5 m (1.64 ft)

Synchronous motors

Linear motors for SINAMICS S120

1FN3 standard type linear motors
Version for peak load – water cooling

Selection and Ordering Data

Motor type Primary section (continued)	Rated current	Maxi- mum cur- rent	Calcu- lated power	SINAMICS S120 Motor Module		Power cable with complete shield Motor connection via adapter cable with power connector for increased velocity/acceleration			
				Required rated current	Booksize format Order No.	Order No.	Cable- cross- section ⁵⁾		Order No.
							Pre-assembled adapter cable for motor	Power con- nector Size	
I_{rated} ¹⁾	I_{MAX}	P_{calc}	$I_{\text{rated}}/$ I_{MAX}						
A	A	kW (HP)	A						
1FN3050-2WC00-...	2.7	8.2	4.1 (5.5)	5/10	6SL312 - - TE15-0AA3	⁶⁾	1	4 x 2.5	6FX8002-5CS11-
1FN3050-2WC00-...	2.7	8.2	4.1 (5.5)	5/10	6SL312 - - TE15-0AA3	⁷⁾	1	4 x 2.5	6FX8002-5CS11-
1FN3100-1WC00-...	2.4	6.5	3.1 (4.2)	5/10	6SL312 - - TE15-0AA3		1	4 x 2.5	6FX8002-5CS11-
1FN3100-2WC00-...	5.1	13.5	6.3 (8.5)	9/18	6SL312 - - TE21-0AA3		1	4 x 2.5	6FX8002-5CS11-
1FN3100-2WE00-...	8.1	21.5	8.3 (11.1)	18/36	6SL312 - - TE21-8AA3		1	4 x 2.5	6FX8002-5CS11-
1FN3100-3WC00-...	7.2	19.1	9.2 (12.3)	18/36	6SL312 - - TE21-8AA3		1	4 x 2.5	6FX8002-5CS11-
1FN3100-3WE00-...	12.1	32.2	12.4 (16.6)	18/36	6SL312 - - TE21-8AA3		1	4 x 2.5	6FX8002-5CS11-
1FN3100-4WC00-...	10.1	27.0	12.6 (16.9)	18/36	6SL312 - - TE21-8AA3		1	4 x 2.5	6FX8002-5CS11-
1FN3100-4WE00-...	16.1	43.0	16.5 (22.1)	30/56	6SL312 - - 1 TE23-0AA3		1	4 x 2.5	6FX8002-5CS11-
1FN3100-5WC00-...	11.0	29.5	14.4 (19.3)	18/36	6SL312 - - TE21-8AA3		1	4 x 2.5	6FX8002-5CS11-
1FN3150-1WC00-...	3.6	9.5	4.3 (5.8)	5/10	6SL312 - - TE15-0AA3		1	4 x 2.5	6FX8002-5CS11-
1FN3150-2WC00-...	7.2	19.1	8.7 (11.7)	18/36	6SL312 - - TE21-8AA3		1	4 x 2.5	6FX8002-5CS11-
1FN3150-3WC00-...	10.7	28.6	13.0 (17.4)	18/36	6SL312 - - TE21-8AA3		1	4 x 2.5	6FX8002-5CS11-
1FN3150-4WC00-...	14.3	38.2	17.4 (23.3)	30/56	6SL312 - - 1 TE23-0AA3		1	4 x 2.5	6FX8002-5CS11-
1FN3150-5WC00-...	17.9	47.7	21.7 (29.1)	30/56	6SL312 - - 1 TE23-0AA3		1	4 x 2.5	6FX8002-5CS11-
1FN3300-1WC00-...	6.5	20.0	8.7 (11.7)	18/36	6SL312 - - TE21-8AA3		1	4 x 2.5	6FX8002-5CS11-
1FN3300-2WB00-...	8.0	24.7	13.2 (17.7)	18/36	6SL312 - - TE21-8AA3		1	4 x 2.5	6FX8002-5CS11-
1FN3300-2WC00-...	12.6	39.2	16.8 (22.5)	30/56	6SL312 - - 1 TE23-0AA3		1	4 x 2.5	6FX8002-5CS11-
1FN3300-2WG00-...	32.2	99.7	30.1 (40.4)	60/113	6SL312 - - 1 TE26-0AA3		1.5	4 x 6	6FX8002-5CS54-
1FN3300-3WC00-...	19.0	58.7	25.1 (33.7)	30/56	6SL312 - - 1 TE23-0AA3		1	4 x 2.5	6FX8002-5CS11-
1FN3300-3WG00-...	50.0	154.9	46.2 (61.9)	132/210	6SL312 - - 1 TE31-3AA3		1.5	4 x 16	6FX8002-5CS24-
1FN3300-4WB00-...	16.0	49.4	26.3 (35.3)	30/56	6SL312 - - 1 TE23-0AA3		1	4 x 2.5	6FX8002-5CS11-
1FN3300-4WC00-...	25.3	78.3	33.5 (44.9)	45/85	6SL312 - - 1 TE24-5AA3		1.5	4 x 4	6FX8002-5CS54-
Cooling:									
Internal air cooling					0				
External air cooling					1				
Motor Module:									
Single Motor Module					1				
Double Motor Module					2				
For length code as well as power and signal cables, see Connection system MOTION-CONNECT.									

Designation	Order No.
Pre-assembled signal cable with M17 connector	
• 1FN3100/1FN3150 motors	6FX7002-2SL01-....
• 1FN3300 to 1FN3900 motors	6FX7002-2SL02-....

¹⁾ For water cooling with inlet temperature 35 °C (95 °F).

²⁾ A reduction of up to 30% must be expected in case of motor standstill, at very low speeds, or with very short traverse paths.

³⁾ Velocity values refer to a converter DC link voltage of 600 V DC.

⁴⁾ No precision cooler available.

⁵⁾ The current carrying capacity of the power cables complies with IEC 60204-1 for installation type C, Table 5, under continuous operating conditions at an ambient air temperature of 40 °C (104 °F).

⁶⁾ Permanently connected power and signal cables, length 2 m (6.56 ft), with open core ends:

⁷⁾ Permanently connected power and signal cables, length 0.5 m (1.64 ft), with power connector size 1 or M17 connector.

Synchronous motors

Linear motors for SINAMICS S120

1FN3 standard type linear motors Version for peak load – water cooling

Selection and Ordering Data

Feedrate force		Maximum velocity ³⁾		1FN3 linear motors – Version for peak load Water cooling		Weight, approx.	
$F_{rated}^{1)2)}$	F_{MAX}	v_{MAX} at F_{MAX}	v_{MAX} at F_{rated}	Primary section	Secondary section	Primary section without/with precision cooling	Secondary section without/with heatsink profiles
N (lb _f)	N (lb _f)	m/min (ft/min)	m/min (ft/min)	Order No.	Order No.	kg (lb)	kg (lb)
1930 (434)	5180 (1165)	30 (98)	112 (368)	1FN3450-2WA50-0BA1	1FN3450-4SA00-0AA0	15.9/17.1 (35.1/37.7)	3.8/4 (8.4/8.8)
1930 (434)	5180 (1165)	120 (394)	275 (902)	1FN3450-2WC00-0BA1		15.9/17.1 (35.1/37.7)	
1930 (434)	5180 (1165)	240 (787)	519 (1703)	1FN3450-2WE00-0BA1		15.9/17.1 (35.1/37.7)	
2895 (651)	7760 (1745)	62 (203)	164 (538)	1FN3450-3WB00-0BA1		22.6/24.3 (49.8/53.6)	
2895 (651)	7760 (1745)	90 (295)	217 (712)	1FN3450-3WB50-0BA1		22.6/24.3 (49.8/53.6)	
2895 (651)	7760 (1745)	120 (394)	275 (902)	1FN3450-3WC00-0BA1		22.6/24.3 (49.8/53.6)	
2895 (651)	7760 (1745)	240 (787)	519 (1703)	1FN3450-3WE00-0BA1		22.6/24.3 (49.8/53.6)	
3860 (868)	10350 (2327)	62 (203)	164 (538)	1FN3450-4WB00-0BA1		30.9/33.1 (68.1/73)	
3860 (868)	10350 (2327)	90 (295)	217 (712)	1FN3450-4WB50-0BA1		30.9/33.1 (68.1/73)	
3860 (868)	10350 (2327)	120 (394)	275 (902)	1FN3450-4WC00-0BA1		30.9/33.1 (68.1/73)	
3860 (868)	10350 (2327)	240 (787)	519 (1703)	1FN3450-4WE00-0BA1	30.9/33.1 (68.1/73)		
2610 (587)	6900 (1551)	36 (118)	120 (394)	1FN3600-2WA50-0BA1	1FN3600-4SA00-0AA0	22.2/24.7 (49/54.5)	4.6/5 (10.1/11)
3915 (880)	10350 (2327)	58 (190)	155 (509)	1FN3600-3WB00-0BA1		31.5/33.4 (69.5/73.7)	
3915 (880)	10350 (2327)	112 (368)	254 (833)	1FN3600-3WC00-0BA1		31.5/33.4 (69.5/73.7)	
5220 (1174)	13800 (3102)	26 (85)	105 (345)	1FN3600-4WA30-0BA1		40.8/43.3 (90/95.5)	
5220 (1174)	13800 (3102)	58 (190)	155 (509)	1FN3600-4WB00-0BA1		40.8/43.3 (90/95.5)	
5220 (1174)	13800 (3102)	91 (299)	215 (705)	1FN3600-4WB50-0BA1		40.8/43.3 (90/95.5)	
5220 (1174)	13800 (3102)	112 (368)	254 (833)	1FN3600-4WC00-0BA1		40.8/43.3 (90/95.5)	
4050 (910)	10350 (2327)	65 (213)	160 (525)	1FN3900-2WB00-0BA1		1FN3900-4SA00-0AA0	28.2/29.7 (62.2/65.4)
4050 (910)	10350 (2327)	115 (377)	253 (830)	1FN3900-2WC00-0BA1	28.2/29.7 (62.2/65.4)		
6075 (1366)	15530 (3491)	75 (246)	181 (594)	1FN3900-3WB00-0BA1	42.2/44.3 (93.1/97.6)		
8100 (1821)	20700 (4653)	65 (213)	160 (525)	1FN3900-4WB00-0BA1	56.2/58.9 (124/130)		
8100 (1821)	20700 (4653)	88 (290)	203 (666)	1FN3900-4WB50-0BA1	56.2/58.9 (124/130)		
8100 (1821)	20700 (4653)	115 (377)	253 (830)	1FN3900-4WC00-0BA1	56.2/58.9 (124/130)		

Type of connection:

Frame sizes 1FN3100 to 1FN3900

Connection cover prepared for separate power and signal cables

B

¹⁾ For water cooling with inlet temperature 35 °C (95 °F).

²⁾ A reduction of up to 30% must be expected in case of motor standstill, at very low speeds, or with very short traverse paths.

³⁾ Velocity values refer to a converter DC link voltage of 600 V DC.

Synchronous motors

Linear motors for SINAMICS S120

1FN3 standard type linear motors
Version for peak load – water cooling

Selection and Ordering Data

Motor type Primary section (continued)	Rated cur- rent	Maxi- mum cur- rent	Calcu- lated power	SINAMICS S120 Motor Module		Power cable with complete shield Motor connection via adapter cable with power connector for increased velocity/acceleration			
				Required rated current	Booksize format Order No.	Order No.		Cable- cross- section ⁴⁾	Order No.
						Pre-assembled adapter cable for motor	Power con- nector		
I_{rated}^1	I_{MAX}	P_{calc}	$I_{\text{rated}}/I_{\text{MAX}}$	A		Size	mm ²		
1FN3450-2WA50-...	8.6	25.3	15.9 (21.3)	18/36	6SL312 ■ - ■ TE21-8AA3	6FX7002-5LM62-	1	4 x 2.5	6FX8002-5CS11-
1FN3450-2WC00-...	18.8	55.3	23.1 (31)	30/56	6SL312 ■ - 1 TE23-0AA3	6FX7002-5LM62-	1	4 x 2.5	6FX8002-5CS11-
1FN3450-2WE00-...	33.8	99.7	32.6 (43.7)	60/113	6SL312 ■ - 1 TE26-0AA3	6FX7002-5LM82-	1.5	4 x 6	6FX8002-5CS54-
1FN3450-3WB00-...	17.9	52.7	27.5 (36.9)	30/56	6SL312 ■ - 1 TE23-0AA3	6FX7002-5LM62-	1	4 x 2.5	6FX8002-5CS11-
1FN3450-3WB50-...	22.8	67.3	31.1 (41.7)	45/85	6SL312 ■ - 1 TE24-5AA3	6FX7002-5LM72-	1.5	4 x 4	6FX8002-5CS54-
1FN3450-3WC00-...	28.1	83.0	34.6 (46.4)	45/85	6SL312 ■ - 1 TE24-5AA3	6FX7002-5LM72-	1.5	4 x 4	6FX8002-5CS54-
1FN3450-3WE00-...	50.7	149.6	48.9 (65.6)	132/210	6SL312 ■ - 1 TE31-3AA3	6FX7002-5LM02-	1.5	4 x 16	6FX8002-5CS24-
1FN3450-4WB00-...	23.8	70.3	36.7 (49.2)	45/85	6SL312 ■ - 1 TE24-5AA3	6FX7002-5LM72-	1.5	4 x 4	6FX8002-5CS54-
1FN3450-4WB50-...	30.4	89.8	41.4 (55.5)	60/113	6SL312 ■ - 1 TE26-0AA3	6FX7002-5LM82-	1.5	4 x 6	6FX8002-5CS54-
1FN3450-4WC00-...	37.5	110.6	46.2 (61.9)	60/113	6SL312 ■ - 1 TE26-0AA3	6FX7002-5LM32-	1.5	4 x 10	6FX8002-5CS64-
1FN3450-4WE00-...	67.6	199.5	65.3 (87.5)	132/210	6SL312 ■ - 1 TE31-3AA3	6FX7008-1BB61- ⁵⁾	–	4 x 25	6FX7008-1BB25- ⁶⁾
1FN3600-2WA50-...	12.4	36.0	21.9 (29.4)	18/36	6SL312 ■ - ■ TE21-8AA3	6FX7002-5LM62-	1	4 x 2.5	6FX8002-5CS11-
1FN3600-3WB00-...	23.2	67.3	35.4 (47.5)	45/85	6SL312 ■ - 1 TE24-5AA3	6FX7002-5LM72-	1.5	4 x 4	6FX8002-5CS54-
1FN3600-3WC00-...	35.2	102.4	41.6 (55.8)	60/113	6SL312 ■ - 1 TE26-0AA3	6FX7002-5LM82-	1.5	4 x 6	6FX8002-5CS54-
1FN3600-4WA30-...	22.3	64.9	41.8 (56.1)	45/85	6SL312 ■ - 1 TE24-5AA3	6FX7002-5LM72-	1.5	4 x 4	6FX8002-5CS54-
1FN3600-4WB00-...	30.9	89.8	47.2 (63.3)	60/113	6SL312 ■ - 1 TE26-0AA3	6FX7002-5LM82-	1.5	4 x 6	6FX8002-5CS54-
1FN3600-4WB50-...	40.8	118.5	52.2 (70)	85/141	6SL312 ■ - 1 TE28-5AA3	6FX7002-5LM32-	1.5	4 x 10	6FX8002-5CS64-
1FN3600-4WC00-...	46.9	136.5	55.5 (74.4)	85/141	6SL312 ■ - 1 TE28-5AA3	6FX7002-5LM32-	1.5	4 x 10	6FX8002-5CS64-
1FN3900-2WB00-...	24.7	69.5	34.5 (46.3)	45/85	6SL312 ■ - 1 TE24-5AA3	6FX7002-5LM72-	1.5	4 x 4	6FX8002-5CS54-
1FN3900-2WC00-...	36.7	103.3	41.0 (55)	60/113	6SL312 ■ - 1 TE26-0AA3	6FX7002-5LM32-	1.5	4 x 10	6FX8002-5CS64-
1FN3900-3WB00-...	40.6	114.0	54.5 (73.1)	85/141	6SL312 ■ - 1 TE28-5AA3	6FX7002-5LM32-	1.5	4 x 10	6FX8002-5CS64-
1FN3900-4WB00-...	49.4	138.9	68.9 (92.4)	132/210	6SL312 ■ - 1 TE31-3AA3	6FX7002-5LM32-	1.5	4 x 10	6FX8002-5CS64-
1FN3900-4WB50-...	60.6	170.3	76.3 (102.3)	132/210	6SL312 ■ - 1 TE31-3AA3	6FX7002-5LM02-	1.5	4 x 16	6FX8002-5CS24-
1FN3900-4WC00-...	73.5	206.5	81.9 (109.8)	132/210	6SL312 ■ - 1 TE31-3AA3	6FX7008-1BB61- ⁵⁾	–	4 x 25	6FX7008-1BB25- ⁶⁾
Cooling: Internal air cooling					0				
External air cooling					1				
Motor Module: Single Motor Module					1				
Double Motor Module					2				
For length code as well as power and signal cables, see Connection system MOTION-CONNECT.					

Designation	Order No.
Pre-assembled signal cable with M17 connector	
• 1FN3100/1FN3150 motors	6FX7002-2SL01-....
• 1FN3300 to 1FN3900 motors	6FX7002-2SL02-....

⁴⁾ The current carrying capacity of the power cables complies with IEC 60204-1 for installation type C, Table 5, under continuous operating conditions at an ambient air temperature of 40 °C (104 °F).

⁵⁾ Sold by the meter only (4 x 16 mm²). Connected to primary section with 16 mm² (< 1.5 m (4.92 ft)) then routed onwards through terminal box with 25 mm².

⁶⁾ Sold by the meter only (4 x 25 mm²).

Synchronous motors

Linear motors for SINAMICS S120

1FN3 standard type linear motors Version for continuous load – water cooling

Selection and Ordering Data

Feedrate force		Maximum velocity ³⁾		1FN3 linear motors – Version for continuous load Water cooling		Weight, approx.	
F_{rated} ¹⁾²⁾	F_{MAX}	v_{MAX} at F_{MAX}	v_{MAX} at F_{rated}	Primary section	Secondary section	Primary section without/with precision cooling	Secondary section without/with heatsink profiles
N (lb _f)	N (lb _f)	m/min (ft/min)	m/min (ft/min)	Order No.	Order No.	kg (lb)	kg (lb)
150 (34)	260 (58)	242 (794)	435 (1427)	1FN3050-1ND00-0EA1	1FN3050-4SA00-0AA0	1.9/2.3 (4.2/5.1)	0.4/0.5 (0.9/1.1)
150 (34)	260 (58)	242 (794)	435 (1427)	1FN3050-1ND00-0FA1		1.9/2.3 (4.2/5.1)	
300 (67)	510 (115)	108 (354)	202 (663)	1FN3050-2NB80-0EA1		3.2/3.9 (7.1/8.6)	
300 (67)	510 (115)	108 (354)	202 (663)	1FN3050-2NB80-0FA1		3.2/3.9 (7.1/8.6)	
300 (67)	510 (115)	117 (384)	214 (702)	1FN3100-1NC00-0BA1	1FN3100-4SA00-0AA0	3/3.5 (6.6/7.7)	0.7/0.8 (1.5/1.8)
605 (136)	1020 (229)	170 (558)	307 (1007)	1FN3100-2NC80-0BA1		5.1/5.9 (11.3/13.1)	
905 (203)	1530 (344)	115 (337)	211 (692)	1FN3100-3NC00-0BA1		7.3/8.3 (16.1/18.03)	
1205 (271)	2040 (459)	169 (555)	305 (1001)	1FN3100-4NC80-0BA1		10/11.9 (22.1/26.2)	
455 (102)	770 (173)	129 (423)	234 (768)	1FN3150-1NC20-0BA1	1FN3150-4SA00-0AA0	4.1/4.6 (9.0/10.1)	1.2/1.3 (2.7/2.9)
905 (203)	1530 (344)	110 (361)	201 (660)	1FN3150-2NB80-0BA1		7.2/8.1 (15.9/17.9)	
1360 (306)	2300 (517)	163 (535)	292 (958)	1FN3150-3NC70-0BA1		10.5/11.6 (23.2/25.6)	
1810 (407)	3060 (688)	109 (358)	200 (656)	1FN3150-4NB80-0BA1		13.8/15.2 (30.4/33.5)	
865 (195)	1470 (331)	129 (423)	230 (755)	1FN3300-1NC10-0BA1	1FN3300-4SA00-0AA0	8.8/9.5 (19.4/20.9)	2.4/2.6 (5.3/5.7)
1730 (389)	2940 (661)	127 (417)	228 (748)	1FN3300-2NC10-0BA1		16.1/17.2 (35.5/37.9)	
2595 (583)	4400 (989)	144 (473)	257 (843)	1FN3300-3NC40-0BA1		22.8/24.3 (50.3/53.6)	
3460 (778)	5870 (1320)	109 (358)	196 (643)	1FN3300-4NB80-0BA1		30.4/32.3 (67.0/71.2)	
2595 (583)	4400 (989)	153 (502)	271 (889)	1FN3450-2NC50-0BA1	1FN3450-4SA00-0AA0	22/23.2 (48.5/51.2)	3.8/4 (8.4/8.8)
3890 (875)	6600 (1484)	152 (499)	270 (886)	1FN3450-3NC50-0BA1		32/32.7 (70.6/72.1)	
5185 (1166)	8810 (1981)	106 (348)	190 (623)	1FN3450-4NB80-0BA1		42.3/44.4 (93.3/97.9)	
3460 (778)	5870 (1320)	112 (368)	200 (656)	1FN3600-2NB80-0BA1	1FN3600-4SA00-0AA0	28.9/30.4 (63.7/67.0)	4.6/5 (10.1/11)
5185 (1166)	8810 (1981)	111 (364)	199 (653)	1FN3600-3NB80-0BA1		42.9/45.0 (94.6/99.2)	
6915 (1555)	11740 (2639)	111 (364)	199 (653)	1FN3600-4NB80-0BA1		56.6/59.2 (124.8/130.54)	
5185 (1166)	8810 (1981)	71 (233)	130 (427)	1FN3900-2NB20-0BA1	1FN3900-4SA00-0AA0	42.4/44.2 (93.5/97.5)	7.5/7.9 (16.5/17.4)
7780 (1749)	13210 (2970)	71 (233)	129 (423)	1FN3900-3NB20-0BA1		62/64.5 (136.7/142.2)	
10375 (2332)	17610 (3959)	70 (230)	129 (423)	1FN3900-4NB20-0BA1		82.2/85.4 (181.3/188.3)	

Type of connection:

Frame sizes 1FN3100 to 1FN3900

Connection cover prepared for separate power and signal cables

Frame size 1FN3050

Permanently connected power and signal cables with open core ends

Length: 2 m (6.56 ft)

Frame size 1FN3050

Permanently connected power and signal cables pre-assembled, with connectors

Length: 0.5 m (1.64 ft)

B

E

F

¹⁾ For water cooling with inlet temperature 35 °C (95 °F).

²⁾ A reduction of up to 30% must be expected in case of motor standstill, at very low speeds, or with very short traverse paths.

³⁾ Velocity values refer to a converter DC link voltage of 600 V DC.

Synchronous motors

Linear motors for SINAMICS S120

1FN3 standard type linear motors
Version for continuous load – water cooling

Selection and Ordering Data

Motor type Primary section (continued)	Rated current	Maxi- mum current	Calcu- lated power	SINAMICS S120 Motor Module		Power cable with complete shield Motor connection via adapter cable with power connector for increased velocity/acceleration			
				Required rated current	Booksize format Order No.	Order No.	Cable cross- section ⁵⁾		Order No.
							Pre-assembled adapter cable for motor	Power con- nector Size	
I_{rated}^1	I_{MAX}	P_{calc}	$I_{\text{rated}}/$ I_{MAX}						
A	A	kW (HP)	A						
1FN3050-1ND...	2.8	5.9	1.8 (2.4)	3/6	6SL312 ■ - ■ TE13-0AA3 ⁶⁾		1	4 x 2.5	6FX8002-5CS11-
1FN3050-1ND...	2.8	5.9	1.8 (2.4)	3/6	6SL312 ■ - ■ TE13-0AA3 ⁶⁾		1	4 x 2.5	6FX8002-5CS11-
1FN3050-2NB...	2.8	5.9	2.4 (3.2)	3/6	6SL312 ■ - ■ TE13-0AA3 ⁶⁾		1	4 x 2.5	6FX8002-5CS11-
1FN3050-2NB...	2.8	5.9	2.4 (3.2)	3/6	6SL312 ■ - ■ TE13-0AA3 ⁶⁾		1	4 x 2.5	6FX8002-5CS11-
1FN3100-1NC...	2.8	5.9	2.1 (2.8)	3/6	6SL312 ■ - ■ TE13-0AA3	6FX7002-5LM42-	1	4 x 2.5	6FX8002-5CS11-
1FN3100-2NC...	8	16.5	5.2 (7)	9/18	6SL312 ■ - ■ TE21-0AA3	6FX7002-5LM42-	1	4 x 2.5	6FX8002-5CS11-
1FN3100-3NC...	8.5	17.6	6.3 (8.5)	9/18	6SL312 ■ - ■ TE21-0AA3	6FX7002-5LM42-	1	4 x 2.5	6FX8002-5CS11-
1FN3100-4NC...	15.9	33.1	10.3 (13.8)	18/36	6SL312 ■ - ■ TE21-8AA3	6FX7002-5LM42-	1	4 x 2.5	6FX8002-5CS11-
1FN3150-1NC...	4.5	9.4	3.2 (4.3)	5/10	6SL312 ■ - ■ TE15-0AA3	6FX7002-5LM42-	1	4 x 2.5	6FX8002-5CS11-
1FN3150-2NB...	8	16.5	5.9 (7.9)	9/18	6SL312 ■ - ■ TE21-0AA3	6FX7002-5LM42-	1	4 x 2.5	6FX8002-5CS11-
1FN3150-3NC...	16.9	35.2	10.8 (14.5)	18/36	6SL312 ■ - ■ TE21-8AA3	6FX7002-5LM42-	1	4 x 2.5	6FX8002-5CS11-
1FN3150-4NB...	15.9	33.1	11.7 (15.7)	18/36	6SL312 ■ - ■ TE21-8AA3	6FX7002-5LM42-	1	4 x 2.5	6FX8002-5CS11-
1FN3300-1NC...	8.1	17.1	5.4 (7.2)	9/18	6SL312 ■ - ■ TE21-0AA3	6FX7002-5LM62-	1	4 x 2.5	6FX8002-5CS11-
1FN3300-2NC...	16.2	34.1	10.8 (14.5)	18/36	6SL312 ■ - ■ TE21-8AA3	6FX7002-5LM62-	1	4 x 2.5	6FX8002-5CS11-
1FN3300-3NC...	27.3	57.4	17.4 (23.3)	30/56 ⁴⁾	6SL312 ■ - 1 TE23-0AA3	6FX7002-5LM72-	1.5	4 x 4	6FX8002-5CS41-
1FN3300-4NB...	28.4	59.6	19.8 (26.6)	30/56 ⁴⁾	6SL312 ■ - 1 TE23-0AA3	6FX7002-5LM72-	1.5	4 x 4	6FX8002-5CS41-
1FN3450-2NC...	28.4	59.6	17.5 (23.5)	30/56 ⁴⁾	6SL312 ■ - 1 TE23-0AA3	6FX7002-5LM72-	1.5	4 x 4	6FX8002-5CS41-
1FN3450-3NC...	42.5	89.5	26.2 (35.1)	45/85 ⁴⁾	6SL312 ■ - 1 TE24-5AA3	6FX7002-5LM32-	1.5	4 x 10	6FX8002-5CS64-
1FN3450-4NB...	40.8	85.8	28.1 (37.7)	45/85 ⁴⁾	6SL312 ■ - 1 TE24-5AA3	6FX7002-5LM32-	1.5	4 x 10	6FX8002-5CS64-
1FN3600-2NB...	28.4	59.6	19.1 (25.6)	30/56 ⁴⁾	6SL312 ■ - 1 TE23-0AA3	6FX7002-5LM72-	1.5	4 x 4	6FX8002-5CS41-
1FN3600-3NB...	42.5	89.5	28.5 (38.2)	45/85 ⁴⁾	6SL312 ■ - 1 TE24-5AA3	6FX7002-5LM32-	1.5	4 x 10	6FX8002-5CS64-
1FN3600-4NB...	56.7	119.3	38 (51)	60/113 ⁴⁾	6SL312 ■ - 1 TE26-0AA3	6FX7002-5LM02-	1.5	4 x 16	6FX8002-5CS24-
1FN3900-2NB...	28.4	59.6	22 (29.5)	30/56 ⁴⁾	6SL312 ■ - 1 TE23-0AA3	6FX7002-5LM72-	1.5	4 x 4	6FX8002-5CS41-
1FN3900-3NB...	42.5	89.5	32.9 (44.1)	45/85 ⁴⁾	6SL312 ■ - 1 TE24-5AA3	6FX7002-5LM32-	1.5	4 x 10	6FX8002-5CS64-
1FN3900-4NB...	56.7	119.3	43.8 (58.7)	60/113 ⁴⁾	6SL312 ■ - 1 TE26-0AA3	6FX7002-5LM02-	1.5	4 x 16	6FX8002-5CS24-
Cooling:									
Internal air cooling					0				
External air cooling					1				
Motor Module:									
Single Motor Module					1				
Double Motor Module					2				
For length code as well as power and signal cables, see Connection system MOTION-CONNECT.									
					

Designation

Order No.

Pre-assembled signal cable with M17 connector

- 1FN3100/1FN3150 motors
- 1FN3300 to 1FN3900 motors

6FX7002-2SL01-....

6FX7002-2SL02-....

⁴⁾ Power modules are designed for feedrate force F_{rated} . If feedrate force F_{MAX} is utilized, the next largest power module must be used. If a power module with a higher rating is used, you must check whether the specified power cable can be connected to it.

⁵⁾ The current carrying capacity of the power cables complies with IEC 60204-1 for installation type C, Table 5, under continuous operating conditions at an ambient air temperature of 40 °C (104 °F).

⁶⁾ Permanently connected power and signal cables.

Synchronous motors

Linear motors for SINAMICS S120

1FN3 standard type linear motors

Water cooling

Selection and Ordering Data

1FN3 linear motors Type	Optional components Secondary section cover		Cover end pieces for secondary section cover ²⁾ Retaining of the integrated cover without heat sink profiles Order No.
	Integrated ¹⁾ Order No.	Segmented Order No.	
1FN3050-...	1FN3050-0TB00-1 ■ ■ 0	1FN3050-4TP00-1A ■ ■	1FN3050-0TC00-0AA0
1FN3100-...	1FN3100-0TB00-1 ■ ■ 0	1FN3100-4TP00-1A ■ ■	1FN3100-0TC00-0AA0
1FN3150-...	1FN3150-0TB00-1 ■ ■ 0	1FN3150-4TP00-1A ■ ■	1FN3150-0TC00-0AA0
1FN3300-...	1FN3300-0TB00-1 ■ ■ 0	1FN3300-4TP00-1A ■ ■	1FN3300-0TC00-0AA0
1FN3450-...	1FN3450-0TB00-1 ■ ■ 0	1FN3450-4TP00-1A ■ ■	1FN3450-0TC00-0AA0
1FN3600-...	1FN3600-0TB00-1 ■ ■ 0	1FN3600-4TP00-1A ■ ■	–
1FN3900-...	1FN3900-0TB00-1 ■ ■ 0	1FN3900-4TP00-1A ■ ■	–

Number of secondary sections	Number of secondary sections for all frame sizes		Number of secondary sections for frame sizes 1FN3600/1FN3900	
	0	A	2.5	C
10	B	3	D	0
20	C	3.5	D	5
30	D	4	E	0
40	E	5	F	0
50	F			
0	A	5.5	F	5
1	B	6.5	G	5
2	C			
3	D			
4	E			
5	F			
6	G			
7	H			
8	J			
9	K			

1FN3 linear motors Version for peak load	Optional components Precision cooler
Type	Order No.
1FN3050-2W...	1FN3050-2PK00-0AA0
1FN3100-2W...	1FN3100-2PK00-0AA0
1FN3100-3W...	1FN3100-3PK00-0AA0
1FN3100-4W...	1FN3100-4PK00-0AA0
1FN3100-5W...	1FN3100-5PK00-0AA0
1FN3150-2W...	1FN3150-2PK00-0AA0
1FN3150-3W...	1FN3150-3PK00-0AA0
1FN3150-4W...	1FN3150-4PK00-0AA0
1FN3150-5W...	1FN3150-5PK00-0AA0
1FN3300-2W...	1FN3300-2PK00-0AA0
1FN3300-3W...	1FN3300-3PK00-0AA0
1FN3300-4W...	1FN3300-4PK00-0AA0
1FN3450-2W...	1FN3450-2PK00-0AA0
1FN3450-3W...	1FN3450-3PK00-0AA0
1FN3450-4W...	1FN3450-4PK00-0AA0
1FN3600-2W...	1FN3600-2PK00-0AA0
1FN3600-3W...	1FN3600-3PK00-0AA0
1FN3600-4W...	1FN3600-4PK00-0AA0
1FN3900-2W...	1FN3900-2PK00-0AA0
1FN3900-3W...	1FN3900-3PK00-0AA0
1FN3900-4W...	1FN3900-4PK00-0AA0

1FN3 linear motors Version for continuous load	Optional components Precision cooler
Type	Order No.
1FN3050-1N...	1FN3050-1PK10-0AA0
1FN3050-2N...	1FN3050-2PK10-0AA0
1FN3100-1N...	1FN3100-1PK10-0AA0
1FN3100-2N...	1FN3100-2PK10-0AA0
1FN3100-3N...	1FN3100-3PK10-0AA0
1FN3100-4N...	1FN3100-4PK10-0AA0
1FN3150-1N...	1FN3150-1PK10-0AA0
1FN3150-2N...	1FN3150-2PK10-0AA0
1FN3150-3N...	1FN3150-3PK10-0AA0
1FN3150-4N...	1FN3150-4PK10-0AA0
1FN3300-1N...	1FN3300-1PK10-0AA0
1FN3300-2N...	1FN3300-2PK10-0AA0
1FN3300-3N...	1FN3300-3PK10-0AA0
1FN3300-4N...	1FN3300-4PK10-0AA0
1FN3450-2N...	1FN3450-2PK10-0AA0
1FN3450-3N...	1FN3450-3PK10-0AA0
1FN3450-4N...	1FN3450-4PK10-0AA0
1FN3600-2N...	1FN3600-2PK10-0AA0
1FN3600-3N...	1FN3600-3PK10-0AA0
1FN3600-4N...	1FN3600-4PK10-0AA0
1FN3900-2N...	1FN3900-2PK10-0AA0
1FN3900-3N...	1FN3900-3PK10-0AA0
1FN3900-4N...	1FN3900-4PK10-0AA0

¹⁾ Integrated cover for several secondary sections. The maximum length of the secondary section cover is 6 m (19.7 ft). For the following frame sizes, this corresponds to: 1FN3050 to 1FN3150, a maximum number of 50 secondary sections (AB to FA). 1FN3300 to 1FN3900, a maximum number of 32 secondary sections (AB to DC).

²⁾ The secondary section end pieces are designed to allow clamping of the integrated secondary section cover.

Synchronous motors

Linear motors for SINAMICS S120

1FN3 standard type linear motors
Water cooling

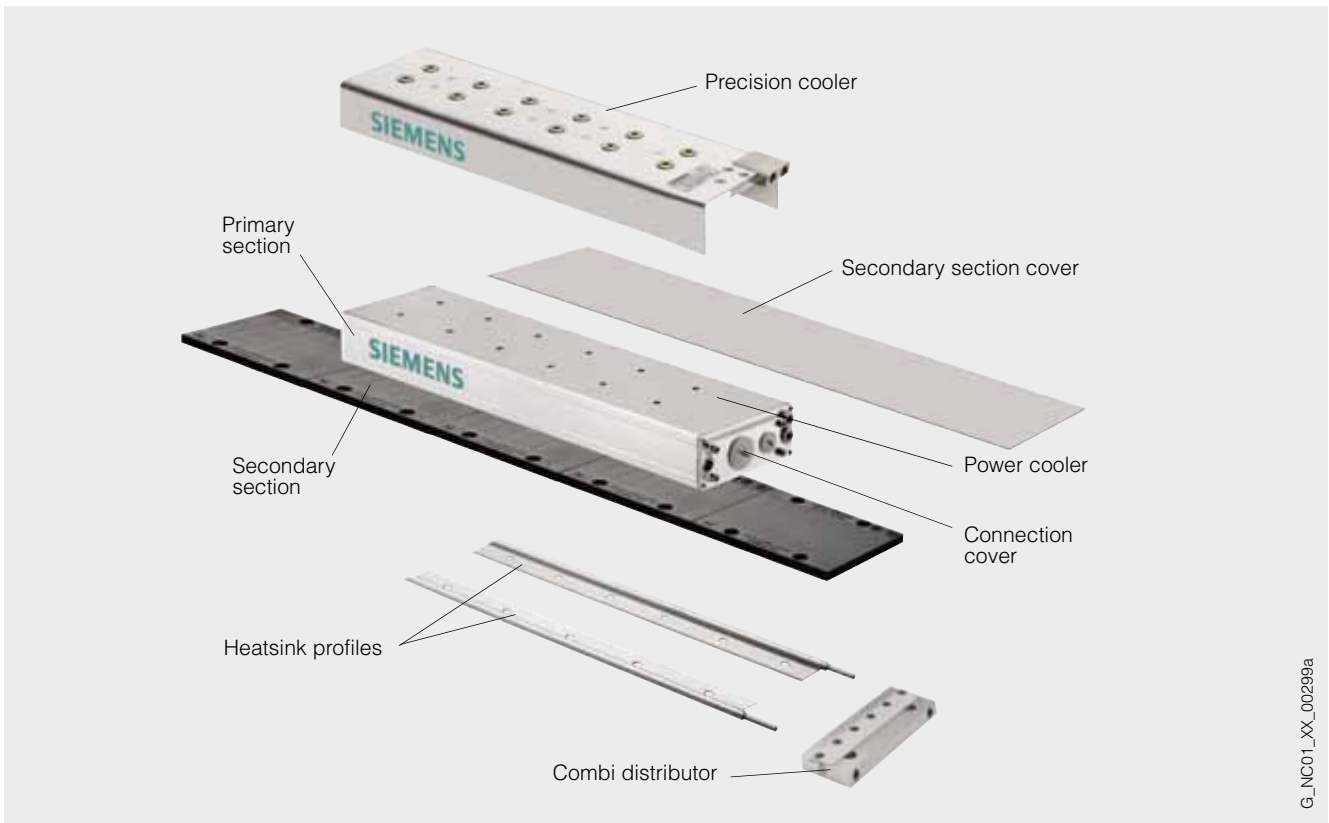

G_NC01_XX_00299a

6

Selection and Ordering Data

Linear motors Type	Optional components			
	Heatsink profile ³⁾	Secondary section end pieces ²⁾		
		Combi distributor	Combi adapter	Combi end piece
		Parallel water connection for all heatsink profiles	Combi adapter and end piece can only be implemented together. Single-sided water connection	Water diversion
	Order No.	Order No.	Order No.	Order No.
1FN3050-...	1FN3002-0TK0 ■ -1 ■ ■ 0	1FN3050-0TJ01-0AA0	1FN3050-0TG01-0AA0	1FN3050-0TF01-0AA0
1FN3100-...	1FN3002-0TK0 ■ -1 ■ ■ 0	1FN3100-0TJ01-0AA0	1FN3100-0TG01-0AA0	1FN3100-0TF01-0AA0
1FN3150-...	1FN3002-0TK0 ■ -1 ■ ■ 0	1FN3150-0TJ01-0AA0	1FN3150-0TG01-0AA0	1FN3150-0TF01-0AA0
1FN3300-...	1FN3003-0TK0 ■ -1 ■ ■ 0	1FN3300-0TJ01-0AA0	1FN3300-0TG01-0AA0	1FN3300-0TF01-0AA0
1FN3450-...	1FN3003-0TK0 ■ -1 ■ ■ 0	1FN3450-0TJ01-0AA0	1FN3450-0TG01-0AA0	1FN3450-0TF01-0AA0
1FN3600-...	1FN3004-0TK0 ■ -1 ■ ■ 0	1FN3600-0TJ01-0AA0	–	–
1FN3900-...	1FN3005-0TK0 ■ -1 ■ ■ 0	1FN3900-0TJ01-0AA0	–	–

With plug-in coupling prepared for connection to combi distributor with plug-in coupling, combi adapter with plug-in coupling, combi end piece with plug-in coupling or as intermediate unit for heatsink profile with cable grommet nipple

Frame sizes 1FN3050 to 1FN3450⁴⁾:
Grommet nipple only on right end of secondary section track

Frame sizes 1FN3600/1FN3900:
Grommet nipple on both ends of secondary section track

Frame sizes 1FN3050 to 1FN3450⁴⁾:
Grommet nipple only on left end of secondary section track

	Number of secondary sections
4	0
A	10
B	20
C	
A	0
B	1
C	2
D	3
E	4
F	5
G	6
H	7
I	8
J	9
K	

³⁾ Frame sizes 1FN3050 to 1FN3450:
2 units per secondary section track.
1FN3600 to 1FN3900:
3 units per secondary section track.
The maximal available length of a single-part heatsink profile is 3 m (9.84 ft).
For the following frame sizes, this corresponds to:
1FN3050 to 1FN3150, a maximum of 24 secondary sections (AB to CE)
1FN3300 to 1FN3900, a maximum of 16 secondary sections (AB to BG).

⁴⁾ Available only in length AC (equals 2 secondary sections). The difference in the secondary section track length must be compensated through assembly with the heatsink profile 1FN300.-0TK04-1..0.

Synchronous motors

Linear motors for SINAMICS S120

1FN3 linear motors Hall-effect sensor box

Overview



The motor position can be identified with an incremental linear measuring system using an additional hall-effect sensor box, or also motion-based if certain supplementary conditions are taken into account.

1FN3 linear motors Connector box

Overview



A connector box is required to connect a hall-effect sensor box (option).

Selection and Ordering Data

Linear motor	Hall-effect sensor box	
1FN3	Straight cable outlet	Cable outlet at side
Type	Order No.	Order No.

Mounted opposite primary section terminal end

1FN3050-2... 1FN3100-2... 1FN3100-4... 1FN3150-2... 1FN3150-4...	1FN3002-0PH00-0AA0	1FN3002-0PH01-0AA0
--	---------------------------	---------------------------

1FN3100-1... 1FN3100-3... 1FN3100-5... 1FN3150-1... 1FN3150-3... 1FN3150-5...	1FN3005-0PH00-0AA0	1FN3005-0PH01-0AA0
--	---------------------------	---------------------------

1FN3300-2... 1FN3300-4... 1FN3450-2... 1FN3450-4... 1FN3600-2... 1FN3600-4... 1FN3900-2... 1FN3900-4...	1FN3003-0PH00-0AA0	1FN3003-0PH01-0AA0
--	---------------------------	---------------------------

1FN3300-1... 1FN3300-3... 1FN3450-3... 1FN3600-3... 1FN3900-3...	1FN3006-0PH00-0AA0	1FN3006-0PH01-0AA0
--	---------------------------	---------------------------

Mounted on primary section terminal end

1FN3050-... 1FN3100-... 1FN3150-...	1FN3002-0PH00-0AA0	1FN3002-0PH01-0AA0
---	---------------------------	---------------------------

1FN3300-... 1FN3450-... 1FN3600-... 1FN3900-...	1FN3003-0PH00-0AA0	1FN3003-0PH01-0AA0
--	---------------------------	---------------------------

Technical specifications

Product name	Connector box
Degree of protection in accordance with EN 60529-5 (IEC 60529)	IP65
Permissible air humidity in accordance with DIN 40040	95% (without condensation)
Dimensions (without sockets or cable glands)	
• Width	69.6 mm (2.74 in)
• Height	54 mm (2.13 in)
• Depth	25 mm (0.98 in)
Weight, approx.	0.26 kg (0.57 lb)

Selection and Ordering Data

Designation	Order No.
Connector box	1FN1910-0AA00-0AA0
For connecting an incremental encoder	

Synchronous motors

Linear motors for SINAMICS S120

1FN3 linear motors Measuring systems

1FN3 linear motors Liquid cooling

Overview

Recommended linear measuring systems for 1FN3 linear motors

Type	Absolute encoder EnDat enclosed	
	LC 183	LC 483
Signal cycle	20 µm	20 µm
Acceleration in measuring direction, max.	100 m/s ² (328 ft/s ²)	100 m/s ² (328 ft/s ²)
Traversing velocity, max.	180 m/min (591 ft/min)	180 m/min (591 ft/min)
Measuring length, max.	3040 mm (120 in)	2040 mm (80.3 in)
Output signal	1 V _{pp}	1 V _{pp}

Type	Incremental encoder sin/cos 1 V _{pp} enclosed	
	LS 187 (C)	LS 487 (C)
Signal cycle	20 µm	20 µm
Acceleration in measuring direction, max.	100 m/s ² (328 ft/s ²)	100 m/s ² (328 ft/s ²)
Traversing velocity, max.	120 m/min (394 ft/min)	120 m/min (394 ft/min)
Measuring length, max.	3040 mm (120 in)	2040 mm (80.3 in)
Output signal	1 V _{pp}	1 V _{pp}

Type	Incremental encoder sin/cos 1 V _{pp} open		
	LIDA 185	LIDA 485	Renishaw RG2
Signal cycle	40 µm	20 µm	20 µm
Acceleration in measuring direction, max.	200 m/s ² (656 ft/s ²) ¹⁾	200 m/s ² (656 ft/s ²) ¹⁾	300 m/s ² (984 ft/s ²) ¹⁾
Traversing velocity, max.	480 m/min (1575 ft/min)	480 m/min (1575 ft/min)	300 m/min (984 ft/min)
Measuring length, max.	30040 mm (1183 in)	30040 mm (1183 in)	50000 mm (1968 in)
Output signal	1 V _{pp}	1 V _{pp}	1 V _{pp}

Overview

Non-Siemens products whose fundamental suitability is familiar to us. It goes without saying that equivalent products from other manufacturers may be used. Our recommendations are to be seen as helpful information, not as requirements or dictates. We do not warrant the composition, nature, state or quality of non-Siemens products.

Please get in touch with the contact persons of the cooler manufacturers listed below for technical information.

BKW Kälte-Wärme-Versorgungstechnik GmbH

Benzstraße 2
72649 WOLFSCHLUGEN, Germany
Phone: +49 (0) 70 22 - 50 03 - 0
Fax: +49 (0) 70 22 - 50 03 - 30
E-mail: info@bkw-kuema.de
www.bkw-kuema.de

Helmut Schimpke und Team Industriekühlanlagen GmbH + Co. KG

Contact person: Ginsterweg 25-27
Mr. Gerken 42781 HAAN, Germany
Phone: +49 (0) 21 29 - 94 38 - 0
Fax: +49 (0) 21 29 - 94 38 - 99
E-mail: info@schimpke.de
www.schimpke.de

Hydac System GmbH

Contact person: Postfach 12 51
Mr. Klein 66273 SULZBACH/SAAR, Germany
Phone: +49 (0) 68 97 - 5 09 - 7 08
Fax: +49 (0) 68 97 - 5 09 - 4 54
E-mail: winfried.klein@hydac.com
www.hydac.com

Pfannenberg GmbH

Contact person: Werner-Witt-Straße 1
Mr. Hille 21035 HAMBURG, Germany
Phone: +49 (0) 40 - 7 34 12 - 1 27
Fax: +49 (0) 40 - 7 34 12 - 1 01
E-mail: werner.hille@pfannenberg.com
www.pfannenberg.com

Rittal GmbH & Co. KG

Contact person: Postfach 16 62
Mr. Cieslar 35726 HERBORN, Germany
Phone: +49 (0) 27 72 - 5 05 - 20 63
Fax: +49 (0) 27 72 - 5 05 - 29 66
E-mail: cieslar.g@rittal.de
www.rittal.de

For design of the coolers, see Configuration Manual (see documentation for Order No.).

¹⁾ Refers to the measuring head.

Synchronous motors

Torque motors for SINAMICS S120

1FW6 standard type built-in torque motors Water cooling

Overview

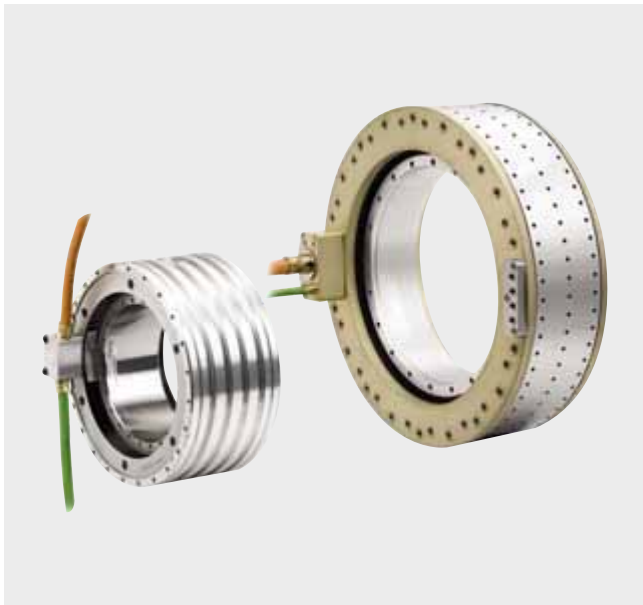

1FW6 built-in torque motors are liquid-cooled, multi-pole permanent-magnet-excited AC synchronous motors with hollow-shaft rotor. The 1FW6 motors are supplied as built-in components that are held together in the delivered state by transport locks. For a complete drive unit, an additional bearing and shaft encoder are required.

Each frame size is available in different axis lengths. The stator and rotor are equipped with flanges at each end with centering surfaces and threaded holes for installation in the machine.

Please note that when 1FW6 direct motors (torque motors) are used in fork heads for machine tools or robots, a license for US patent US5584621 and the associated international patent protection may be required.

Benefits

- No elasticity in the drive train
- High availability, since there are no gear components subject to wear in the drive train
- High torque, compact design and low construction volume
- Low moment of inertia
- Direct coupling to the machine using flanges

Application

In conjunction with the SINAMICS S120 drive system, the built-in torque motors can be used as direct drive for the following machine applications:

- Rotary indexing machines, rotary tables, swivel axes
- Rotary axes (A, B, C axis in 5-axis machine tools)
- Turret indexing and cylinder indexing for single-spindle and multi-spindle machines
- Dynamic tool magazines
- Rotating spindles in milling machines
- Roller and cylinder drives
- Infeed and handling axes

Design

The 1FW6 built-in torque motor comprises the following components:

Stator

Iron core with a 3-phase AC winding. To improve dissipation of the heat loss, the motor can be force-cooled by means of a liquid cooler (main cooler).

Rotor

Cylindrical hollow shaft made of steel with permanent magnets fixed to the circumference.

If the main cooler and precision cooler are used together in a heat exchanger, a cooling connection adapter (accessory) can be ordered separately for simpler connection.

Cooler types

The design of the cooler system is dependent on the size (external diameter) of the motor.

1FW6 motor Type	Type of cooling
1FW6090/1FW6130	Jacket cooling
1FW6160 to 1FW6290	Integrated cooling

Synchronous motors

Torque motors for SINAMICS S120

1FW6 standard type built-in torque motors
Water cooling

Design (continued)

Motors with jacket cooling

The coolant inlet and outlet must be provided by the machine manufacturer in the surrounding construction.



Motor components of sizes 1FW6090/1FW6130 with jacket cooling (rotor, stator)

Motors with integrated cooling

These motors feature a ready-to-connect, integrated dual-circuit cooling system and are therefore thermally insulated against the mechanical axis construction to a considerable extent.

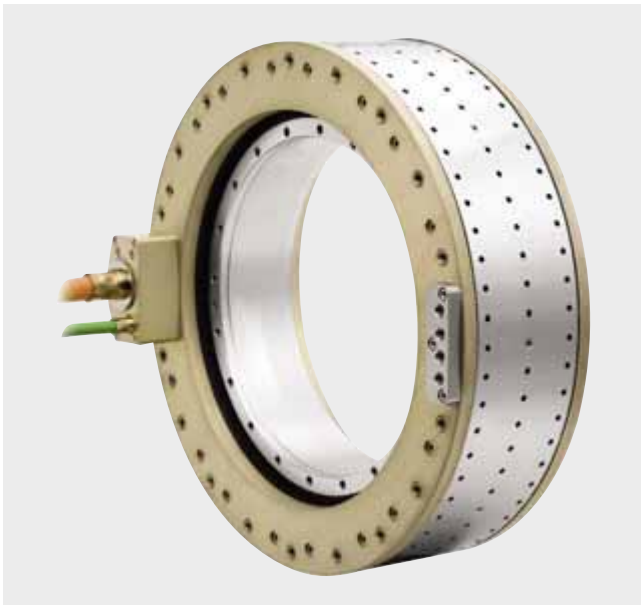

Motor components of sizes 1FW6160 to 1FW6290 with integrated cooling (rotor, stator)

Integration

The 1FW6 motors which must be fed from the SINAMICS S120 drive system are designed for operation on a 600 V DC-link voltage level and require a sinusoidal current.

The cable connection is brought out of the front face of the stator and the free cable end must be connected to a terminal box provided by the machine manufacturer. The length of the power and signal cables from the motor to the drive system must not exceed 50 m (164 ft).

Technical specifications

Product name	1FW6 built-in torque motors
Type of motor	Synchronous motor with permanent magnet rotor, multi-pole (number of rotor poles 44 ... 98)
Torque ripple	$\leq 1.5\% M_0$
Insulation of the stator winding in accordance with EN 60034-1 (IEC 60034-1)	Temperature class 155 (F)
Type	Individual components: Stator, rotor
Degree of protection in accordance with IEC 60034-5	IP23 The final degree of protection (minimum degree of protection is IP54) for the installed motor is determined by the machine manufacturer. Protection against touch, foreign bodies and water for electrical equipment is specified in accordance with IEC 60034-5.
Coolant inlet temperature, max.	35 °C (95 °F)
Pressure in cooling circuit, max.	10 bar (static)
Temperature monitoring	2 x PTC thermistor drilled hole with response threshold 130/150 °C (266/302 °F) (in accordance with DIN 44081/44082) and 1 x KTY84 thermistor (in accordance with IEC 60034-11) in the stator. Evaluation via Sensor Module External SME120/SME125. ¹⁾
Paint finish	Unpainted
Encoder system (not included in scope of supply)	The encoder must be selected according to the mechanical and converter-specific boundary conditions.
Connection, electrical	Permanently connected power and signal cables

¹⁾ For SME120/SME125, see SINAMICS S120 drive system.

Synchronous motors

Torque motors for SINAMICS S120

1FW6 standard type built-in torque motors Water cooling

Selection and Ordering Data

Maximum torque	Static torque ¹⁾³⁾	Rated torque ²⁾³⁾	Max. speed at maximum torque ²⁾	Max. speed at rated torque ²⁾	1FW6 built-in torque motors Water cooled	Moment of inertia of rotor	Weight, approx. stator + rotor
M_{max}	M_0	M_{rated}	n_{max} at M_{max}	n_{max} at M_{rated}	Order No. Standard type	J	m
Nm (lb _f -in)	Nm (lb _f -in)	Nm (lb _f -in)	rpm	rpm		10 ⁻² kgm ² (lb _f -in-s ²)	kg (lb)
179 (1584)	119 (1053)	113 (1000)	46	140	1FW6090-0 B05-0F 2	1.52 (0.13)	9.2 (20.3)
		109 (965)	140	250	1FW6090-0 B05-0K 2	1.52 (0.13)	9.2 (20.3)
251 (2221)	166 (1469)	154 (1363)	120	220	1FW6090-0 B07-0K 2	2.2 (0.19)	12.2 (27)
		142 (1257)	270	430	1FW6090-0 B07-1J 2	2.2 (0.19)	12.2 (27)
358 (3168)	238 (2106)	231 (2044)	8.7	82	1FW6090-0 B10-0K 2	3.09 (0.27)	17.2 (37.9)
		216 (1912)	170	270	1FW6090-0 B10-1J 2	3.09 (0.27)	17.2 (37.9)
537 (4752)	357 (3159)	338 (2991)	78	150	1FW6090-0 B15-1J 2	4.65 (0.41)	27.2 (60)
		319 (2823)	200	310	1FW6090-0 B15-2J 2	4.65 (0.41)	27.2 (60)
439 (3885)	258 (2283)	241 (2133)	47	130	1FW6130-0 B05-0K 2	6.37 (0.56)	13.2 (29.1)
		217 (1920)	180	310	1FW6130-0 B05-1J 2	6.37 (0.56)	13.2 (29.1)
614 (5434)	361 (3195)	344 (3044)	21	96	1FW6130-0 B07-0K 2	8.92 (0.79)	18.2 (40.1)
		324 (2867)	110	200	1FW6130-0 B07-1J 2	8.92 (0.79)	18.2 (40.1)
878 (7770)	516 (4567)	484 (4283)	50	120	1FW6130-0 B10-1J 2	12.7 (1.12)	25.2 (55.6)
		450 (3983)	150	250	1FW6130-0 B10-2J 2	12.7 (1.12)	25.2 (55.6)
1320 (11682)	775 (6859)	744 (6584)	14	78	1FW6130-0 B15-1J 2	19.1 (1.69)	38.2 (84.2)
		714 (6319)	77	150	1FW6130-0 B15-2J 2	19.1 (1.69)	38.2 (84.2)

Cable outlet for 1FW6090/1FW6130 only:

Axial
Radially outwards
Tangential

P
Q
N

Type of connection:

Permanently connected power and signal cables with open core ends
Length: 2 m (6.56 ft)
Permanently connected power and signal cables pre-assembled with connectors
Length: 0.5 m (1.64 ft)

C
D

Synchronous motors

Torque motors for SINAMICS S120

1FW6 standard type built-in torque motors
Water cooling

Selection and Ordering Data

Motor type (continued)	Static current ¹⁾³⁾		Rated current ²⁾³⁾		Maximum current ²⁾		Calculated power		SINAMICS S120 Motor Module		Power cable with complete shield Motor connection via power connector ⁵⁾		
	I_0	I_{rated}	I_{max}	$P_{el, max}$	Required rated current	Booksized format	Power connector	Cable cross-section ⁶⁾	Order No. Pre-assembled basic cable to converter	Order No.	Size	Motor mm ²	
	A	A	A	kW (HP)	A	Order No.							
1FW6090-0.B05-0F..	5.9	5.6	9.5	6.55 (8.78)	5/10 ⁴⁾	6SL312 ■ - ■ TE15-0AA3	1	4 x 2.5	6FX8002-5CS11-....				
1FW6090-0.B05-0K..	8.2	7.4	13	8.12 (10.88)	9/18	6SL312 ■ - ■ TE21-0AA3	1	4 x 2.5	6FX8002-5CS11-....				
1FW6090-0.B07-0K..	10	9.5	16	10.3 (13.8)	9/18 ⁴⁾	6SL312 ■ - ■ TE21-0AA3	1	4 x 2.5	6FX8002-5CS11-....				
1FW6090-0.B07-1J..	16	13	26	14.1 (18.9)	18/36	6SL312 ■ - ■ TE21-8AA3	1	4 x 2.5	6FX8002-5CS11-....				
1FW6090-0.B10-0K..	8.2	7.9	13	9.43 (12.6)	9/18	6SL312 ■ - ■ TE21-0AA3	1	4 x 2.5	6FX8002-5CS11-....				
1FW6090-0.B10-1J..	16	14	26	15.3 (20.5)	18/36	6SL312 ■ - ■ TE21-8AA3	1	4 x 2.5	6FX8002-5CS11-....				
1FW6090-0.B15-1J..	16	15	26	17.1 (22.9)	18/36	6SL312 ■ - ■ TE21-8AA3	1	4 x 2.5	6FX8002-5CS11-....				
1FW6090-0.B15-2J..	26	23	43	24.1 (32.3)	30/56	6SL312 ■ - 1 TE23-0AA3	1.5	4 x 4	6FX8002-5CS41-....				
1FW6130-0.B05-0K..	9.7	9	18	12.2 (16.4)	9/18 ⁴⁾	6SL312 ■ - ■ TE21-0AA3	1	4 x 2.5	6FX8002-5CS11-....				
1FW6130-0.B05-1J..	17	14	32	18.3 (24.5)	18/36	6SL312 ■ - ■ TE21-8AA3	1	4 x 2.5	6FX8002-5CS11-....				
1FW6130-0.B07-0K..	10	10	20	14.2 (19)	9/18 ⁴⁾	6SL312 ■ - ■ TE21-0AA3	1	4 x 2.5	6FX8002-5CS11-....				
1FW6130-0.B07-1J..	17	15	32	19.7 (26.4)	18/36	6SL312 ■ - ■ TE21-8AA3	1	4 x 2.5	6FX8002-5CS11-....				
1FW6130-0.B10-1J..	17	16	32	21.4 (28.7)	18/36	6SL312 ■ - ■ TE21-8AA3	1	4 x 2.5	6FX8002-5CS11-....				
1FW6130-0.B10-2J..	28	24	53	30.6 (41)	30/56	6SL312 ■ - 1 TE23-0AA3	1.5	4 x 4	6FX8002-5CS41-....				
1FW6130-0.B15-1J..	19	18	36	25.4 (34.1)	18/36 ⁴⁾	6SL312 ■ - ■ TE21-8AA3	1	4 x 2.5	6FX8002-5CS11-....				
1FW6130-0.B15-2J..	28	26	54	34.1 (45.7)	30/56	6SL312 ■ - 1 TE23-0AA3	1.5	4 x 4	6FX8002-5CS41-....				
Cooling:													
Internal air cooling										0			
External air cooling										1			
Motor Module:													
Internal air cooling										1			
External air cooling										2			
For length code as well as power and signal cables, see Connection system MOTION-CONNECT.												

¹⁾ Torque and current at low speeds.

²⁾ The values refer to a supply voltage of 400 V 3 AC ±10% (converter DC link voltage 600 V DC).

³⁾ In case of water cooling with inlet temperature of 35 °C (95 °F) and maximum rotor flange temperature of 60 °C (140 °F).

⁴⁾ Selection optimized to size of power module. The next higher power module offers 100% torque utilization.

⁵⁾ Permanently connected power and signal cables.

⁶⁾ The current carrying capacity of the power cables complies with IEC 60204-1 for installation type C, Table 5, under continuous operating conditions at an ambient air temperature of 40 °C (104 °F).

Synchronous motors

Torque motors for SINAMICS S120

1FW6 standard type built-in torque motors Water cooling

Selection and Ordering Data

Maximum torque	Static torque ¹⁾³⁾	Rated torque ²⁾³⁾	Max. speed at maximum torque ²⁾	Max. speed at rated torque ²⁾	1FW6 built-in torque motors Water cooled	Moment of inertia of rotor	Weight, approx. stator + rotor
M_{max}	M_0	M_{rated}	n_{max} at M_{max}	n_{max} at M_{rated}	Order No. Standard type	J	m
Nm (lb _f -in)	Nm (lb _f -in)	Nm (lb _f -in)	rpm	rpm		kgm ² (lb _f -in-s ²)	kg (lb)
716 (6337)	467 (4133)	431 (3814)	84	140	1FW6160-0 ■ B05-1J ■ 2	0.19 (1.682)	36.3 (80.0)
		404 (3575)	150	250	1FW6160-0 ■ B05-2J ■ 2	0.19 (1.682)	36.3 (80.0)
1000 (8850)	653 (5779)	620 (5487)	53	96	1FW6160-0 ■ B07-1J ■ 2	0.258 (2.283)	48.3 (107)
		594 (5257)	100	170	1FW6160-0 ■ B07-2J ■ 2	0.258 (2.283)	48.3 (107)
1430 (12656)	933 (8257)	903 (7992)	29	60	1FW6160-0 ■ B10-1J ■ 2	0.36 (3.186)	66.3 (146)
		878 (7770)	65	110	1FW6160-0 ■ B10-2J ■ 2	0.36 (3.186)	66.3 (146)
2150 (19028)	1400 (12390)	1350 (11948)	34	66	1FW6160-0 ■ B15-2J ■ 2	0.531 (4.699)	95.3 (210)
		1280 (11328)	97	160	1FW6160-0 ■ B15-5G ■ 2	0.531 (4.699)	95.3 (210)
990 (8762)	672 (5947)	633 (5602)	54	97	1FW6190-0 ■ B05-1J ■ 2	0.358 (3.168)	42.8 (94.4)
		605 (5354)	96	160	1FW6190-0 ■ B05-2J ■ 2	0.358 (3.168)	42.8 (94.4)
1390 (12302)	941 (8328)	905 (8009)	33	63	1FW6190-0 ■ B07-1J ■ 2	0.486 (4.142)	55.8 (123)
		879 (7779)	64	110	1FW6190-0 ■ B07-2J ■ 2	0.486 (4.142)	55.8 (123)
1980 (17523)	1340 (11859)	1310 (11594)	14	38	1FW6190-0 ■ B10-1J ■ 2	0.678 (6.0)	75.8 (167)
		1290 (11417)	39	70	1FW6190-0 ■ B10-2J ■ 2	0.678 (6.0)	75.8 (167)
2970 (26285)	2020 (17877)	1970 (17435)	17	40	1FW6190-0 ■ B15-2J ■ 2	0.998 (8.832)	107.8 (238)
		1890 (16727)	62	100	1FW6190-0 ■ B15-5G ■ 2	0.998 (8.832)	107.8 (238)

Cable outlet for 1FW6160 to 1FW6290 only:

Axial
Radially outwards
Tangential

W
V
T

Type of connection:

Permanently connected power and signal cables with open core ends
Length: 2 m (6.56 ft)
Permanently connected power and signal cables pre-assembled with connectors
Length: 0.5 m (1.64 ft)

C
D

Synchronous motors

Torque motors for SINAMICS S120

1FW6 standard type built-in torque motors
Water cooling

Selection and Ordering Data

Motor type (continued)	Static current ¹⁾³⁾		Maximum current ²⁾	Calculated power	SINAMICS S120 Motor Module		Power cable with complete shield Motor connection via power connector ⁴⁾		
	I_0	I_{rated}			Required rated current	Booksized format	Power connector	Cable cross-section ⁵⁾	Order No. Pre-assembled basic cable to converter
			Order No.	Size					
1FW6 160-0.B05-1J..	17	16	31	15.1 (20.2)	18/36	6SL312 - - TE21-8AA3	1	4 x 2.5	6FX8002-5CS11-....
1FW6 160-0.B05-2J..	28	24	49	20 (26.8)	30/56	6SL312 - - 1 TE23-0AA3	1.5	4 x 4	6FX8002-5CS41-....
1FW6 160-0.B07-1J..	17	16	31	16.7 (22.4)	18/36	6SL312 - - TE21-8AA3	1	4 x 2.5	6FX8002-5CS11-....
1FW6 160-0.B07-2J..	28	25	49	21.8 (29.2)	30/56	6SL312 - - 1 TE23-0AA3	1.5	4 x 4	6FX8002-5CS41-....
1FW6 160-0.B10-1J..	17	17	31	19 (25.5)	18/36	6SL312 - - TE21-8AA3	1	4 x 2.5	6FX8002-5CS11-....
1FW6 160-0.B10-2J..	28	26	49	24.4 (32.7)	30/56	6SL312 - - 1 TE23-0AA3	1.5	4 x 4	6FX8002-5CS41-....
1FW6 160-0.B15-2J..	28	26	49	28.2 (37.8)	30/56	6SL312 - - 1 TE23-0AA3	1.5	4 x 4	6FX8002-5CS41-....
1FW6 160-0.B15-5G..	56	50	98	42.6 (57.1)	60/113	6SL312 - - 1 TE26-0AA3	1.5	4 x 16	6FX8002-5CS24-....
1FW6 190-0.B05-1J..	18	17	31	16.3 (21.9)	18/36	6SL312 - - TE21-8AA3	1	4 x 2.5	6FX8002-5CS11-....
1FW6 190-0.B05-2J..	27	24	47	20.6 (27.6)	30/56	6SL312 - - 1 TE23-0AA3	1.5	4 x 4	6FX8002-5CS41-....
1FW6 190-0.B07-1J..	18	17	31	18.2 (24.4)	18/36	6SL312 - - TE21-8AA3	1	4 x 2.5	6FX8002-5CS11-....
1FW6 190-0.B07-2J..	27	25	47	22.7 (30.4)	30/56	6SL312 - - 1 TE23-0AA3	1.5	4 x 4	6FX8002-5CS41-....
1FW6 190-0.B10-1J..	18	17	31	20.7 (27.8)	18/36	6SL312 - - TE21-8AA3	1	4 x 2.5	6FX8002-5CS11-....
1FW6 190-0.B10-2J..	27	26	47	25.7 (34.5)	30/56	6SL312 - - 1 TE23-0AA3	1.5	4 x 4	6FX8002-5CS41-....
1FW6 190-0.B15-2J..	27	26	47	30.1 (40.4)	30/56	6SL312 - - 1 TE23-0AA3	1.5	4 x 4	6FX8002-5CS41-....
1FW6 190-0.B15-5G..	54	50	95	44.1 (59.1)	60/113	6SL312 - - 1 TE26-0AA3	1.5	4 x 16	6FX8002-5CS24-....

Cooling:

Internal air cooling
External air cooling

0
1

Motor Module:

Internal air cooling
External air cooling

1
2

For length code as well as power and signal cables, see Connection system MOTION-CONNECT.

....

¹⁾ Torque and current at low speeds.

²⁾ The values refer to a supply voltage of 400 V 3 AC ±10% (converter DC link voltage 600 V DC).

³⁾ In case of water cooling with inlet temperature of 35 °C (95 °F) and maximum rotor flange temperature of 60 °C (140 °F).

⁴⁾ Permanently connected power and signal cables.

⁵⁾ The current carrying capacity of the power cables complies with IEC 60204-1 for installation type C, Table 5, under continuous operating conditions at an ambient air temperature of 40 °C (104 °F)

Synchronous motors

Torque motors for SINAMICS S120

1FW6 standard type built-in torque motors Water cooling

Selection and Ordering Data

Maximum torque	Static torque ¹⁾³⁾	Rated torque ²⁾³⁾	Max. speed at maximum torque ²⁾	Max. speed at rated torque ²⁾	1FW6 built-in torque motors Water cooled Order No. Standard type	Moment of inertia of rotor	Weight, approx. stator + rotor
M_{max}	M_0	M_{rated}	n_{max} at M_{max}	n_{max} at M_{rated}		J	m
Nm (lb _f -in)	Nm (lb _f -in)	Nm (lb _f -in)	rpm	rpm		kgm ² (lb _f -in-s ²)	kg (lb)
1320 (11682)	841 (7443)	799 (7071)	34	69	1FW6230-0 ■ B05-1J ■ 2	0.622 (5.505)	44.8 (98.8)
		774 (6850)	59	110		1FW6230-0 ■ B05-2J ■ 2	0.622 (5.505)
1840 (16284)	1180 (10443)	1140 (10089)	19	45	1FW6230-0 ■ B07-1J ■ 2	0.843 (7.460)	58.8 (130)
		1120 (9912)	38	73		1FW6230-0 ■ B07-2J ■ 2	0.843 (7.460)
2630 (23276)	1680 (14868)	1630 (14426)	21	46	1FW6230-0 ■ B10-2J ■ 2	1.18 (10.443)	81.8 (180)
		1520 (13452)	74	130		1FW6230-0 ■ B10-5G ■ 2	1.18 (10.443)
3950 (34958)	2520 (22302)	2440 (21594)	19	43	1FW6230-0 ■ B15-4C ■ 2	1.73 (15.310)	117.8 (260)
		2380 (21063)	44	80		1FW6230-0 ■ B15-5G ■ 2	1.73 (15.310)
8570 (75854)	4760 (42126)	4590 (40622)	28	53	1FW6290-0 ■ B15-7A ■ 2	4.40 (38.939)	214.6 (473)

Cable outlet for 1FW6160 to 1FW6290 only:

Axial
Radially outwards
Tangential

W
V
T

Type of connection:

Permanently connected power and signal cables with open core ends
Length: 2 m (6.56 ft)
Permanently connected power and signal cables pre-assembled with connectors
Length: 0.5 m (1.64 ft)

C
D

6

Synchronous motors

Torque motors for SINAMICS S120

1FW6 standard type built-in torque motors
Water cooling

Selection and Ordering Data

Motor type (continued)	Static current 1) 3)	Rated current 2) 3)	Maxi- mum current ²⁾	Calculated power	SINAMICS S120 Motor Module		Power cable with complete shield Motor connection via power connector ⁴⁾		
	I_0	I_{rated}	I_{max}	$P_{el, max}$	Required rated current	Booksiz e format	Power connector	Cable cross- section ⁵⁾	Order No. Pre-assembled basic cable to converter
	A	A	A	kW (HP)	I_{rated}/I_{max}	Order No.			
1FW6 230-0.B05-1J..	16	15	31	17.3 (23.2)	18/36	6SL312 - 1 TE21-8AA3	1	4 x 2.5	6FX8002-5CS11-....
1FW6 230-0.B05-2J..	24	22	45	21 (28.2)	30/56	6SL312 - 1 TE23-0AA3	1.5	4 x 4	6FX8002-5CS41-....
1FW6 230-0.B07-1J..	16	16	31	19.4 (26.0)	18/36	6SL312 - 1 TE21-8AA3	1	4 x 2.5	6FX8002-5CS11-....
1FW6 230-0.B07-2J..	24	22	45	23.6 (31.6)	30/56	6SL312 - 1 TE23-0AA3	1.5	4 x 4	6FX8002-5CS41-....
1FW6 230-0.B10-2J..	24	23	45	27.1 (36.3)	30/56	6SL312 - 1 TE23-0AA3	1.5	4 x 4	6FX8002-5CS41-....
1FW6 230-0.B10-5G..	54	48	100	42 (56.3)	60/113	6SL312 - 1 TE26-0AA3	1.5	4 x 16	6FX8002-5CS24-....
1FW6 230-0.B15-4C..	33	32	63	38 (50.9)	45/85	6SL312 - 1 TE24-5AA3	1.5	4 x 6	6FX8002-5CS54-....
1FW6 230-0.B15-5G..	53	49	100	47.4 (63.5)	60/113	6SL312 - 1 TE26-0AA3	1.5	4 x 16	6FX8002-5CS24-....
1FW6 290-0.B15-7A..	64	61	130	65.2 (87.4)	85/141	6SL312 - 1 TE28-5AA3	1.5	4 x 16	6FX8002-5CS24-....

Cooling:

Internal air cooling
External air cooling

0
1

Motor Module:

Internal air cooling
External air cooling

1
2

For length code as well as power and signal cables, see Connection system MOTION-CONNECT.

....

Accessories

Designation	Order No.	Designation	Order No.
Cooling connection adapter for		Power connector	
• Torque motors 1FW6160 to 1FW6230	1FW6160-1BA00-0AA0	• Size 1 for 4 x 2.5 mm ²	6FX2003-1CG10
• Torque motors 1FW6290	1FW6290-1BA00-0AA0	• Size 1.5 for 4 x 4/4 x 10/4 x 16 mm ²	6FX2003-1CG20
		Signal connector	
		• M17 (socket) for 6 x 0.5 + 1 x 1.0 mm ²	6FX2003-0SU07

1) Torque and current at low speeds.

2) The values refer to a supply voltage of 400 V 3 AC ±10% (converter DC link voltage 600 V DC).

3) In case of water cooling with inlet temperature of 35 °C (95 °F) and maximum rotor flange temperature of 60 °C (140 °F).

4) Permanently connected power and signal cables.

5) The current carrying capacity of the power cables complies with IEC 60204-1 for installation type C, Table 5, under continuous operating conditions at an ambient air temperature of 40 °C (104 °F).

Synchronous motors

Main spindle motors for SINAMICS S120

1FE1 standard type built-in motors

Water cooling

Overview



The 1FE1 built-in motors are water-cooled, synchronous motors that are supplied as stator and rotor components. When the rotor has been mounted to the spindle in the spindle box, a complete spindle unit is created.

Benefits

- Compact design (e. g. for turning machines and vertical milling machines) by dispensing with mechanical components, such as motor switch armature, belt drive, gearbox and spindle encoder
- High power density thanks to water cooling
- Maximum speed up to 40000 rpm, torque up to 820 Nm for S1 duty
- Higher torque - up to 60% - with the same active component volume, consequently more compact machine design compared to 1PH2
- Extremely short ramp-up and braking times (50%) thanks to higher torque compared to 1PH2
- Cold rotor due to excitation using permanent magnets, this means significantly less power loss in the rotor in the lower speed range and therefore less bearing heating and spindle expansion
- The stator and rotor are **ready to install**, no finishing is necessary.
- The absence of drive transverse forces permits extremely high accuracy on the workpiece thanks to smooth, accurate spindle motion even at very low speeds.
- Larger rotor inner bore than squirrel-cage rotor of asynchronous motors, but with the same outer diameter, which is an advantage with regard to the bar capacity of automatic turning machines and results in higher spindle stiffness due to larger shaft diameters for milling spindles.
- Increased rigidity of the spindle drive achieved by mounting the motor components between the spindle main bearings
- Less cooling capacity required for the same power compared to 1PH2, i. e. greater efficiency
- Only one encoder (hollow-shaft measuring system) for sensing motor speed and spindle position
- Simple servicing by replacing complete motor spindles

Benefits (continued)

- Compatible system of SINUMERIK, SINAMICS and motor, therefore fast commissioning is ensured
- Higher machine productivity:
The permanent-magnet-excited motor spindles (PE spindles) increase the power density and economic efficiency of CNC machines. The optimized combination of 1FE1 built-in motor, drive control and CNC offers further opportunities for rationalization, such as lower workpiece machining times and fewer clamping faces.

Application

The 1FE1 built-in water-cooled synchronous motors are used in combination with the SINAMICS drive system where there is a requirement for

- excellent machining quality, accuracy and running smoothness, and
- very short ramp-up times.

The 1FE1 built-in motors are offered in two main versions:

- **High-Torque series**
6-pole/8-pole synchronous motors are available that have been developed for turning and grinding machines with moderate maximum speeds.
These motors are characterized by an extremely high torque utilization. In this case, the speed range is approximately 1:2.
- **High-Speed series**
In this series, 4-pole synchronous motors are available for milling. These motors are optimized for high maximum speeds and a speed range of over 1:4. A voltage limitation module is required for these motors when they are operated up to the maximum speed.

Design

The 1FE1 built-in motor comprises:

- A laminated, permanently excited rotor, which, as an option, can be designed with a sleeve for simple mounting and removal.
- A wound stator core with cooling jacket and encapsulated winding overhang.
 - Free cable ends of 0.5 m/1.5 m (1.64 ft/4.92 ft)
 - Two integral PTC thermistors (incl. 1 spare), optionally with full or universal protection
 - A cooling jacket into which the stator has been inserted

Rotor with sleeve

Torque is transmitted to the spindle mechanically without play by means of a cylindrical stepped press fit. The rotor is mounted on the spindle by thermal shrinking.

The rotor with sleeve is pre-balanced and can be removed and subsequently remounted. The bond can be released by pressure-oil injection without affecting the joint surfaces.

Rotor without sleeve

Torque is transmitted to the spindle mechanically without play by means of a cylindrical stepped press fit. The rotor is mounted on the spindle by thermal shrinking.

Removal of the rotor is not possible with this type of mounting. Rotors without sleeves are not pre-balanced.

Synchronous motors Main spindle motors for SINAMICS S120

**1FE1 standard type built-in motors
Water cooling**

Characteristics

Comparison of synchronous/asynchronous spindle

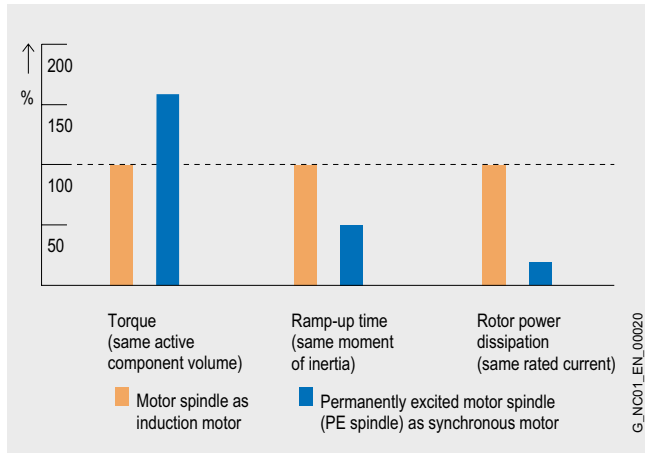

Advantages of 1FE1 synchronous spindle over asynchronous spindle

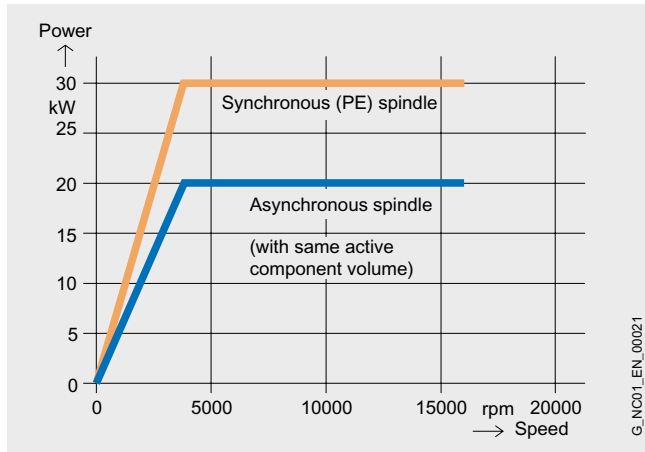

Comparison of power/speed characteristics

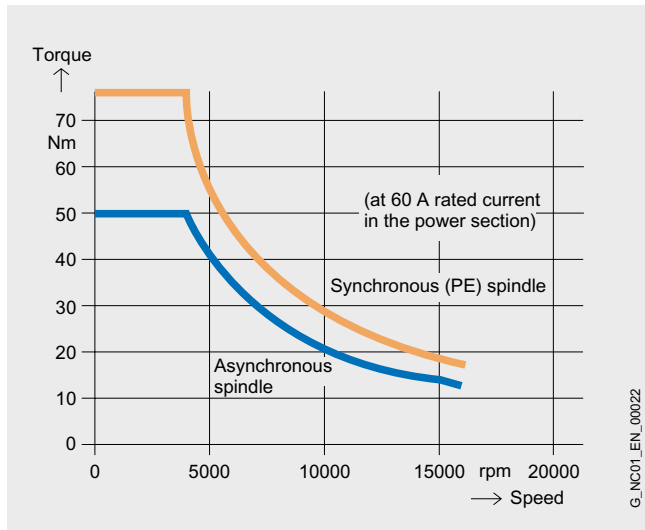

Comparison of torque/speed characteristics

Power/speed and torque/speed characteristics of PE spindles compared to the asynchronous version under the following supplementary conditions: identical active part volume and identical rated current (60 A) of the power section.

Technical specifications

Product name	1FE1 built-in motors
Type of motor	Synchronous spindle with permanent-magnet-excited rotor
Constant power range	1:2 (6-/8-pole) / 1:4 (4-pole)
Insulation of the stator winding in accordance with EN 60034-1 (IEC 60034-1)	Temperature class 155 (F) for a coolant inlet temperature of 25 °C (77 °F)
Type (cf. ISO)	Individual components: Stator, rotor, motor encoder
Degree of protection in accordance with IEC 60034-5	IP00
Recommended coolant inlet temperature, approx.	25 °C (77 °F)
Standard protection – temperature monitoring	2 KTY thermistors in the stator winding, 1 as spare
Full protection optional Application example: processing at motor standstill	In addition to standard protection 3 x PTC thermistor drilling Evaluation possibility e. g. using thermal motor protection: Order No.: 3RN1013-1GW10
Universal protection optional	- Full protection + - NTC PT3-51F - NTC K227
Balance quality of rotor in accordance with ISO 1940-1	<ul style="list-style-type: none"> • Rotor with sleeve Pre-balanced depending on the design, balance quality G 2.5 Reference speed 3600 rpm, or unbalanced for complete balancing after mounting • Rotor without sleeve Not pre-balanced
Recommended motor encoder (not included in scope of supply)	Hollow-shaft measuring system SIMAG H2 or L&B GEL 244 for speeds greater than 33,000 rpm
Motor connection	Free cable ends with l = 0.5/1.5 m (1.64 ft/4.92 ft) length

For a list of heat exchanger manufacturers, please refer to Asynchronous motors – Liquid cooling.

Synchronous motors

Main spindle motors for SINAMICS S120

1FE1 standard type built-in motors

Water cooling

Selection and Ordering Data

Rated power for duty type in accordance with IEC 60034-1 ¹⁾		Rated torque ¹⁾		Rated speed	Speed, max	1FE1 built-in motors Water cooling	Moment of inertia Rotor without sleeve ⁸⁾	Weight (rotor and stator), approx.			
P_{rated}	S6-40%	M_{rated}	S6-40%	n_{rated}	n_{max}				Order No.	J	m
kW (HP)	kW (HP)	Nm (lb _f -in)	Nm (lb _f -in)	rpm	rpm					kgm ² (lb _f -in-s ²)	kg (lb)

High-Torque series, 6-pole

7.4 (9.9)	10 (13.4)	4.5 (39.8)	6 (53.1)	15800	20000	1FE1041-6WM	0- 1 B A	0.00019 (0.0017)	2.8 (6.2)
14.4 (19.3)	18 (24.1)	11 (97)	14 (124)	12500	18000	1FE1042-6WN	0- 1 B A	0.00033 (0.0029)	6.5 (14.3)
11.5 (15.4)	14.6 (19.6)	11 (97)	14 (124)	10000	15000	1FE1042-6WR	0- 1 B A	0.00033 (0.0029)	6.5 (14.3)
6.3 (8.5)	7.9 (10.6)	10 (89)	12.6 (112)	6000	12000	1FE1051-6WN	0- 1 B	0.00106 (0.0094)	5.5 (12.1)
8.3 (11.1)	10.4 (13.9)	10 (89)	12.6 (112)	8000	15000	1FE1051-6WK	0- 1 B	0.00106 (0.0094)	5.5 (12.1)
11.5 (15.4)	14.5 (19.4)	20 (177)	25.2 (223)	5500	12000	1FE1052-6WN	0- 1 B	0.00195 (0.0173)	8.2 (18.1)
14 (18.8)	18 (24.1)	18 (159)	23 (204)	7500	15000	1FE1052-6WK	0- 1 B	0.00195 (0.0173)	8.2 (18.1)
23 (30.8)	29 (38.9)	37 (328)	46 (407)	6000	12000	1FE1054-6WN	0- 1 B A	0.0038 (0.0336)	14.3 (31.5)
11.6 (15.6)	15 (20.1)	13 (115)	17 (151)	8500	12000	1FE1061-6WH	0- 1 B	0.00141 (0.0125)	5.5 (12.1)
4 (5.4)	5.3 (7.1)	13 (115)	17 (151)	3000	5000	1FE1061-6WY	0- 1 B	0.00141 (0.0125)	5.5 (12.1)
25 (33.5)	36.5 (48.9)	56 (496)	81 (717)	4300	12000	1FE1064-6WN	1- 1 B A	0.00553 (0.0489)	14.5 (32)
20 (26.8)	29 (38.9)	56 (496)	81 (717)	3400	10000	1FE1064-6WQ	1- 1 B A	0.00553 (0.0489)	14.5 (32)
34 (45.6)	42 (56.3)	65 (575)	81 (717)	5000	8500	1FE1082-6WP	0- 1 B	0.01048 (0.0927)	14 (30.9)
24.5 (32.8)	30.5 (40.9)	65 (575)	81 (717)	3600	6000	1FE1082-6WS	0- 1 B	0.01048 (0.0927)	14 (30.9)
29.3 (39.3)	36.5 (48.9)	65 (575)	81 (717)	4300	9000	1FE1082-6WQ	1- 1 B	0.01048 (0.0927)	14 (30.9)
15 (20.1)	18.7 (25.1)	65 (575)	81 (717)	2200	9000	1FE1082-6WW	1- 1 B	0.01048 (0.0927)	14 (30.9)
23.1 (31)	31.1 (41.7)	130 (1151)	175 (1549)	1700	7000	1FE1084-6WU	1- 1 B	0.02067 (0.1829)	30 (66.2)
31 (41.6)	42 (56.3)	130 (1151)	175 (1549)	2300	9000	1FE1084-6WR	1- 1 B	0.02067 (0.1829)	30 (66.2)
15 (20.1)	19 (25.5)	130 (1151)	175 (1549)	1100	4500	1FE1084-6WX	1- 1 B	0.02067 (0.1829)	30 (66.2)
10 (13.4)	13.2 (17.7)	28 (248)	36 (319)	3500	7000	1FE1091-6WN	0- 1 B	0.00814 (0.0720)	20 (44.1)
6.3 (8.5)	7.5 (10.1)	30 (266)	36 (319)	2000	4000	1FE1091-6WS	0- 1 B	0.00814 (0.0720)	20 (44.1)
24.2 (32.4)	31 (41.6)	66 (584)	85 (752)	3500	7000	1FE1092-6WN	0- 1 B	0.01566 (0.1386)	30.5 (67.3)
22 (29.5)	28 (37.5)	66 (584)	85 (752)	3200	7000	1FE1092-6WR	1- 1 B	0.0240 (0.2124)	30.5 (67.3)
36.6 (49.1)	47 (63)	100 (885)	128 (1133)	3500	7000	1FE1093-6WN	0- 1 B	0.02317 (0.2051)	41 (90.4)
21 (28.2)	27 (36.2)	100 (885)	128 (1133)	2000	4000	1FE1093-6WS	0- 1 B	0.02317 (0.2051)	41 (90.4)
16.8 (22.5)	21.5 (28.8)	100 (885)	128 (1133)	1600	7000	1FE1093-6WV	1- 1 B	0.02317 (0.2051)	41 (90.4)

- Standard protection: 2xKTY²⁾
 - Full protection: 2xKTY + 3xPTC thermistor drilling⁶⁾
 - Universal protection⁷⁾
- 1
3
5
- Delivery of stator + rotor²⁾⁴⁾⁵⁾
 - Stator with cooling jacket²⁾³⁾
- 1
B
- Without rotor sleeve
 - With rotor sleeve, for d^* see dimensions table
 - With rotor sleeve, for d^{**} see dimensions table
 - With rotor sleeve "-...D." for 1FE1082.../1FE1113-6W... only, see dimensions table
 - With rotor sleeve "-...E." for 1FE1113-6W... only, see dimensions table
- A
B
C
D
E
- Free cable ends, 1.5 m (4.92 ft) in length⁹⁾
Cable outlet at larger outer diameter of cooling jacket
Cable outlet at smaller outer diameter of cooling jacket (on request)
 - Free cable ends, flexible, 0.5 m (1.64 ft) in length (preferred variant)
Cable outlet at larger outer diameter of cooling jacket
Cable outlet at smaller outer diameter of cooling jacket (on request)
- 0
1
2
3

S1 = continuous duty
 S6 = intermittent duty:
 Sizes 40, 50, 60: duty cycle time 1 min
 Sizes 80 to 140: duty cycle time 2 min

Synchronous motors

Main spindle motors for SINAMICS S120

1FE1 standard type built-in motors
Water cooling

Selection and Ordering Data

Motor type (continued)	Rated current for duty type in accordance with IEC 60034-1 ¹⁾		Voltage Protection Module ¹⁰⁾	SINAMICS S120 Motor Module	
	I_{rated}	S6-40%		Required rated current	Booksiz format
	S1	S6-40%		I_{rated}	Order No.
	A	A		S1 to n_{max}	
				A	

High-Torque series, 6-pole

1FE1041-6WM...	13	17.5	–	18	6SL312 ■ - ■ TE21-8AA3
1FE1042-6WN...	24	32	–	45	6SL312 ■ - 1 TE24-5AA3
1FE1042-6WR...	19	26	–	30	6SL312 ■ - 1 TE23-0AA3
1FE1051-6WN...	15	22	–	18	6SL312 ■ - ■ TE21-8AA3
1FE1051-6WK...	20	29	–	30	6SL312 ■ - 1 TE23-0AA3
1FE1052-6WN...	30	44	–	45	6SL312 ■ - 1 TE24-5AA3
1FE1052-6WK...	37	54	–	45	6SL312 ■ - 1 TE24-5AA3
1FE1054-6WN...	60	88	–	85	6SL312 ■ - 1 TE28-5AA3
1FE1061-6WH...	21	30	–	30	6SL312 ■ - 1 TE23-0AA3
1FE1061-6WY...	8	11.5	–	9	6SL312 ■ - ■ TE21-0AA3
1FE1064-6WN...	56	80	VPM 120	60	6SL312 ■ - 1 TE26-0AA3
1FE1064-6WQ...	43	61	VPM 120	45	6SL312 ■ - 1 TE24-5AA3
1FE1082-6WP...	65	91	–	85	6SL312 ■ - 1 TE28-5AA3
1FE1082-6WS...	45	62	–	45	6SL312 ■ - 1 TE24-5AA3
1FE1082-6WQ...	60	84	VPM 120	60	6SL312 ■ - 1 TE26-0AA3
1FE1082-6WW...	30	42	VPM 120	30	6SL312 ■ - 1 TE23-0AA3
1FE1084-6WU...	45	64	VPM 120	45	6SL312 ■ - 1 TE24-5AA3
1FE1084-6WR...	60	84	VPM 120	60	6SL312 ■ - 1 TE26-0AA3
1FE1084-6WX...	30	42	VPM 120	30	6SL312 ■ - 1 TE23-0AA3
1FE1091-6WN...	24	35	–	30	6SL312 ■ - 1 TE23-0AA3
1FE1091-6WS...	15	19	–	30	6SL312 ■ - 1 TE23-0AA3
1FE1092-6WN...	58	84	–	60	6SL312 ■ - 1 TE26-0AA3
1FE1092-6WR...	41	58	VPM 120	45	6SL312 ■ - 1 TE24-5AA3
1FE1093-6WN...	83	120	–	85	6SL312 ■ - 1 TE28-5AA3
1FE1093-6WS...	53	76	–	60	6SL312 ■ - 1 TE26-0AA3
1FE1093-6WV...	43	60	VPM 120	45	6SL312 ■ - 1 TE24-5AA3

Cooling:

Internal air cooling
External air cooling

0
1

Motor Module:

Single Motor Module
Double Motor Module

1
2

- 1) Data for $\Delta T = 105$ K, special windings on request.
- 2) Standard scope of supply: Encapsulated winding with 2xKTY (1 spare).
- 3) Stator without cooling jacket, with impregnated winding on request.
- 4) Ordering spare parts: Stator: 1FE1...-.....-2.W.
- 5) Ordering spare parts: Rotor: 1FE1...-.....-3.W..
- 6) Full protection option, application example: Load at motor standstill, external tripping unit required: Order No. 3RN1013-1GW10.
- 7) Universal protection option: Full protection + NTC PT3-51F + NTC K227.
- 8) For moment of inertia with sleeve, see Configuration Manual.
- 9) For cable design, see Configuration Manual
- 10) Power section with integrated VPM available soon.

Synchronous motors

Main spindle motors for SINAMICS S120

1FE1 standard type built-in motors

Water cooling

Selection and Ordering Data

Rated power for duty type in accordance with IEC 60034-1 ¹⁾		Rated torque ¹⁾		Rated speed	Speed, max.	1FE1 built-in motors Water cooling	Moment of inertia Rotor without sleeve ⁹⁾	Weight (rotor and stator), approx.
P_{rated}	S6-40%	M_{rated}	S6-40%	n_{rated}	n_{max}			
kW (HP)	kW (HP)	Nm (lb _f -in)	Nm (lb _f -in)	rpm	rpm		kgm ² (lb _f -in-s ²)	kg (lb)

High-Torque series, 6-pole

33 (44.2)	35 (46.9)	150 (1328)	190 (1682)	2100	6500	1FE1113-6WU ■ 1- 1 B ■ ■	0.0650 (0.5752)	57 (126)
22 (29.5)	24 (32.2)	150 (1328)	190 (1682)	1400	5700	1FE1113-6WX ■ 1- 1 B ■ ■	0.0650 (0.5752)	57 (126)
41.9 (56.2)	53.6 (71.9)	200 (1770)	256 (2266)	2000	6500	1FE1114-6WR ■ 1- 1 B ■ ■	0.06239 (0.5521)	80 (176)
29.3 (39.3)	37.5 (50.3)	200 (1770)	256 (2266)	1400	6500	1FE1114-6WT ■ 1- 1 B ■ ■	0.06239 (0.5521)	80 (176)
20.9 (28.0)	26.8 (35.9)	200 (1770)	256 (2266)	1000	6000	1FE1114-6WW ■ 1- 1 B ■ ■	0.06239 (0.5521)	80 (176)
41.6 (55.8)	45.0 (60.4)	265 (2345)	340 (3009)	1500	6500	1FE1115-6WT ■ 1- 1 B C ■	0.0780 (0.690)	90 (198)
37.7 (50.5)	48.3 (64.8)	300 (2655)	384 (3399)	1200	6500	1FE1116-6WR ■ 1- 1 B ■ ■	0.09285 (0.8217)	103 (227)
28.3 (37.9)	36.2 (48.5)	300 (2655)	384 (3399)	900	5500	1FE1116-6WT ■ 1- 1 B ■ ■	0.09285 (0.8217)	103 (227)
22 (29.5)	28 (37.5)	300 (2655)	384 (3399)	700	4000	1FE1116-6WW ■ 1- 1 B ■ ■	0.09285 (0.8217)	103 (227)

High-Torque series, 8-pole

63 (84.5)	80 (107)	430 (3806)	620 (5487)	1400	6500	1FE1144-8WL ■ 1- 1 B C ■ ■	0.11440 (1.013)	84.5 (186)
104 (139.4)	124 (166) ²⁾	585 (5188)	795 (7036) ²⁾	1700	8000	1FE1145-8WN ■ 1- 1 B C ■ ■	0.21636 (1.9148)	117 (258)
79.6 (106.7)	96 (129)	585 (5188)	795 (7036)	1300	6000	1FE1145-8WQ ■ 1- 1 B C ■ ■	0.21636 (1.9148)	117 (258)
67.4 (90.4)	80 (107)	585 (5188)	795 (7036)	1100	5000	1FE1145-8WS ■ 1- 1 B C ■ ■	0.21636 (1.9148)	117 (258)
103 (138.1)	124 (166) ²⁾	820 (7258)	1110 (9824) ²⁾	1200	5500	1FE1147-8WN ■ 1- 1 B C ■ ■	0.28823 (2.5508)	155 (342)
81.6 (109.4)	96 (129)	820 (7258)	1110 (9824)	950	4200	1FE1147-8WQ ■ 1- 1 B C ■ ■	0.28823 (2.5508)	155 (342)
64.4 (86.3)	80 (107)	820 (7258)	1110 (9824)	750	3500	1FE1147-8WS ■ 1- 1 B C ■ ■	0.28823 (2.5508)	155 (342)

- Standard protection: 2xKTY³⁾
- Full protection: 2xKTY + 3xPTC thermistor drilling⁷⁾
- Universal protection⁸⁾

1
3
5

- Delivery of stator + rotor³⁾⁵⁾⁶⁾

1

- Stator with cooling jacket³⁾⁴⁾

B

- Without rotor sleeve
- With rotor sleeve, for d^* see dimensions table
- With rotor sleeve, for d^{**} see dimensions table
- With rotor sleeve "-..D." for 1FE1082.../1FE1113-6W... only, see dimensions table
- With rotor sleeve "-..E." for 1FE1113-6W... only, see dimensions table

A
B
C
D
E

- Free cable ends, 1.5 m (4.92 ft) in length¹⁰⁾
Cable outlet at larger outer diameter of cooling jacket
Cable outlet at smaller outer diameter of cooling jacket (on request)
- Free cable ends, flexible, 0.5 m (1.64 ft) in length (preferred variant)
Cable outlet at larger outer diameter of cooling jacket
Cable outlet at smaller outer diameter of cooling jacket (on request)

0
1
2
3

S1 = continuous duty
S6 = intermittent duty:
Sizes 40, 50, 60: duty cycle time 1 min
Sizes 80 to 140: duty cycle time 2 min

Synchronous motors

Main spindle motors for SINAMICS S120

1FE1 standard type built-in motors
Water cooling

Selection and Ordering Data

Motor type (continued)	Rated current for duty type in accordance with IEC 60034-1 ¹⁾		Voltage Protection Module ¹¹⁾	SINAMICS S120 Motor Module	
	I_{rated}	S6-40%		Required rated current	Booksize format
	S1	A		I_{rated} S1	Order No.
	A	A		A	

High-Torque series, 6-pole

1FE1113-6WU...	60	91	VPM 120	60	6SL312 - 1 TE26-0AA3
1FE1113-6WX...	43	62	VPM 120	45	6SL312 - 1 TE24-5AA3
1FE1114-6WR...	108	160	VPM 120	132	6SL312 - 1 TE31-3AA3
1FE1114-6WT...	84	123	VPM 120	85	6SL312 - 1 TE28-5AA3
1FE1114-6WW...	58	85	VPM 120	60	6SL312 - 1 TE26-0AA3
1FE1115-6WT...	85	123	VPM 120	85	6SL312 - 1 TE28-5AA3
1FE1116-6WR...	109	160	VPM 120	132	6SL312 - 1 TE31-3AA3
1FE1116-6WT...	84	123	VPM 120	85	6SL312 - 1 TE28-5AA3
1FE1116-6WW...	60	87	VPM 120	60	6SL312 - 1 TE26-0AA3

High-Torque series, 8-pole

1FE1144-8WL...	133	193	VPM 200	200	6SL312 - 1 TE32-0AA3
1FE1145-8WN...	200	290 ²⁾	VPM 200	200	6SL312 - 1 TE32-0AA3
1FE1145-8WQ...	158	230	VPM 200	200	6SL312 - 1 TE32-0AA3
1FE1145-8WS...	130	188	VPM 200	200	6SL312 - 1 TE32-0AA3
1FE1147-8WN...	200	290 ²⁾	VPM 200	200	6SL312 - 1 TE32-0AA3
1FE1147-8WS...	158	230	VPM 200	200	6SL312 - 1 TE32-0AA3
1FE1147-8WS...	130	190	VPM 200	200	6SL312 - 1 TE32-0AA3

Cooling:

Internal air cooling
External air cooling

0
1

Motor Module:

Single Motor Module

1

- 1) Data for $\Delta T = 105$ K, special windings on request.
- 2) Observe limit for power section.
- 3) Standard scope of supply: Encapsulated winding with 2xKTY (1 spare).
- 4) Stator without cooling jacket, with impregnated winding on request.
- 5) Ordering spare parts: Stator: 1FE1...-.....-2.W.
- 6) Ordering spare parts: Rotor: 1FE1...-.....-3W..
- 7) Full protection option, application example: Load at motor standstill, external tripping unit required: Order No. 3RN1013-1GW10.
- 8) Universal protection option: Full protection + NTC PT3-51F + NTC K227.
- 9) For moment of inertia with sleeve, see Configuration Manual.
- 10) For cable design, see Configuration Manual
- 11) Power section with integrated VPM available soon.

Synchronous motors

Main spindle motors for SINAMICS S120

1FE1 standard type built-in motors Water cooling

Selection and Ordering Data

Rated power for duty type in accordance with IEC 60034-1 ¹⁾		Rated torque ¹⁾		Rated speed	Speed, max.	1FE1 built-in motors Water cooling	Moment of inertia of rotor	Weight (rotor and stator), approx.
P_{rated}	S6-40%	M_{rated}	S6-40%	n_{rated}	n_{max}			
kW (HP)	kW (HP)	Nm (lb _f -in)	Nm (lb _f -in)	rpm	rpm		kgm ² (lb _f -in-s ²)	kg (lb)

High-Speed series, 4-pole

12.6 (16.9)	17.6 (23.6)	5 (44.3)	7 (62)	24000	40000	1FE1051-4HC ■ 0- 1 B A ■	0.00045 (0.004)	4.1 (9.0)
6.5 (8.7)	8.0 (10.7)	6.5 (57.5)	9.0 (79.7)	9500	30000	1FE1051-4WN ■ 1- 1 B A ■	0.00057 (0.005)	4.2 (9.3)
31.4 (42.1)	35 (47)	12 (106)	15.5 (137.2)	25000	40000 ⁸⁾	1FE1052-4HD ■ 0- 1 B A ■	0.00087 (0.007)	7.15 (15.77)
23.9 (32.0)	30 (40)	12 (106)	15.5 (137.2)	19000	40000 ⁸⁾	1FE1052-4HG ■ 1- 1 B A ■	0.00087 (0.007)	7.15 (15.77)
11 (15)	12 (16)	13 (115)	18 (159)	8000	30000	1FE1052-4WN ■ 1- 1 B A ■	0.00110 (0.0097)	7.35 (16.21)
17.5 (23.1)	19 (26)	13 (115)	17 (151)	12500	30000	1FE1052-4WK ■ 1- 1 B A ■	0.00110 (0.0097)	7.35 (16.21)
25.5 (34.2)	32.5 (43.6)	18 (159)	23 (204)	13500	40000 ⁸⁾	1FE1053-4HH ■ 1- 1 B A ■	0.00128 (0.0113)	10.2 (22.5)
23 (31)	25 (34)	20 (177)	27 (239)	11000	30000	1FE1053-4WJ ■ 1- 1 B A ■	0.00163 (0.0144)	10.5 (23.2)
16.5 (22.1)	18 (24)	20 (177)	27 (239)	7900	30000	1FE1053-4WN ■ 1- 1 B A ■	0.00163 (0.0144)	10.5 (23.2)
16 (21)	16 (21)	28 (248)	40 (354)	5500	24000	1FE1072-4WN ■ 1- 1 B A ■	0.00287 (0.0254)	11.2 (24.7)
20 (27)	20 (27)	28 (248)	40 (354)	6800	24000	1FE1072-4WL ■ 1- 1 B A ■	0.00287 (0.0254)	11.2 (24.7)
28.5 (38.2)	28.5 (38.2)	28 (248)	40 (354)	9700	20000	1FE1072-4WH ■ 1- 1 B A ■	0.00287 (0.0254)	11.2 (24.7)
30 (40)	30 (40)	42 (372)	59 (522)	6800	24000	1FE1073-4WN ■ 1- 1 B A ■	0.00430 (0.0381)	16 (35.3)
15 (20)	15 (20)	45 (398)	64 (566)	3200	14000	1FE1073-4WT ■ 1- 1 B A ■	0.00430 (0.0381)	16 (35.3)
41 (55)	41 (55)	56 (496)	79 (699)	7000	20000	1FE1074-4WN ■ 1- 1 B A ■	0.00573 (0.0507)	21 (46.3)
48 (64)	51 (68)	60 (531)	86 (761)	7700	20000	1FE1074-4WM ■ 1- 1 B A ■	0.00573 (0.0507)	21 (46.3)
25.8 (34.6)	28 (38)	60 (531)	85 (752)	4100	18000	1FE1074-4WT ■ 1- 1 B A ■	0.00573 (0.0507)	21 (46.3)
15.5 (20.8)	15.5 (20.8)	42 (372)	55 (487)	3500	20000	1FE1082-4WN ■ 1- 1 B A ■	0.00559 (0.0495)	15.1 (33.3)
8.8 (11.8)	8.8 (11.8)	42 (372)	55 (487)	2000	11000	1FE1082-4WR ■ 1- 1 B A ■	0.00559 (0.0495)	15.1 (33.3)
28 (38)	28 (38)	63 (558)	83 (735)	4200	20000	1FE1083-4WN ■ 1- 1 B A ■	0.00847 (0.0750)	22 (48.5)
38 (51)	38 (51)	84 (744)	110 (974)	4300	20000	1FE1084-4WN ■ 1- 1 B A ■	0.01118 (0.0989)	28.5 (62.9)
35 (47)	35 (47)	78 (690)	110 (974)	4300	20000	1FE1084-4WP ■ 1- 1 B A ■	0.01118 (0.0989)	28.5 (62.9)
30 (40)	30 (40)	84 (743)	110 (974)	3400	18000	1FE1084-4WQ ■ 1- 1 B A ■	0.01118 (0.0989)	28.5 (62.9)
26.4 (35.4)	26.4 (35.4)	84 (743)	110 (974)	3000	15000	1FE1084-4WT ■ 1- 1 B A ■	0.01118 (0.0989)	28.5 (62.9)
38 (51)	38 (51)	105 (929)	138 (1221)	3500	18000	1FE1085-4WN ■ 1- 1 B A ■	0.01388 (0.1228)	35 (77.2)
24 (32)	24 (32)	105 (929)	140 (1239)	2200	12000	1FE1085-4WT ■ 1- 1 B A ■	0.01388 (0.1228)	35 (77.2)
33 (44)	33 (44)	105 (929)	140 (1239)	3000	16000	1FE1085-4WQ ■ 1- 1 B A ■	0.01388 (0.1228)	35 (77.2)

- Standard protection: 2xKTY²⁾
- Full protection: 2xKTY + 3xPTC thermistor drilling⁶⁾
- Universal protection⁷⁾

- Delivery of stator + rotor²⁾⁴⁾⁵⁾

- Stator with cooling jacket²⁾³⁾

- Without rotor sleeve

- Free cable ends, 1.5 m (4.92 ft) in length⁹⁾
Cable outlet at larger outer diameter of cooling jacket
Cable outlet at smaller outer diameter of cooling jacket (on request)
- Free cable ends, flexible, 0.5 m (1.64 ft) in length (preferred variant)
Cable outlet at larger outer diameter of cooling jacket
Cable outlet at smaller outer diameter of cooling jacket (on request)

S1 = continuous duty
S6 = intermittent duty:
Sizes 40, 50, 60: duty cycle time 1 min
Sizes 80 to 140: duty cycle time 2 min

1
3
5

1

B

A

0

1

2

3

Synchronous motors

Main spindle motors for SINAMICS S120

1FE1 standard type built-in motors
Water cooling

Selection and Ordering Data

Motor type (continued)	Rated current for duty type in accordance with IEC 60034-1 ¹⁾		Voltage Protection Module ¹⁰⁾	SINAMICS S120 Motor Module	
	I_{rated}	S6-40%		Required rated current	Booksizе format
	S1	A		I_{rated} S1 to n_{max}	Order No.
	A	A		A	

High-Speed series, 4-pole

1FE1051-4HC...	25	34.5	–	45	6SL312 ■ - 1 TE24-5AA3
1FE1051-4WN...	12	17	VPM 120	18	6SL312 ■ - ■ TE21-8AA3
1FE1052-4HD...	57	75	–	132	6SL312 ■ - 1 TE31-3AA3
1FE1052-4HG...	44	59	VPM 120	85	6SL312 ■ - 1 TE28-5AA3
1FE1052-4WN...	20	26	VPM 120	30	6SL312 ■ - 1 TE23-0AA3
1FE1052-4WK...	30	39	VPM 120	45	6SL312 ■ - 1 TE24-5AA3
1FE1053-4HH...	46	63	VPM 120	85	6SL312 ■ - 1 TE28-5AA3
1FE1053-4WJ...	36	49	VPM 120	60	6SL312 ■ - 1 TE26-0AA3
1FE1053-4WN...	29	38	VPM 120	45	6SL312 ■ - 1 TE24-5AA3
1FE1072-4WN...	36	54	VPM 120	45	6SL312 ■ - 1 TE24-5AA3
1FE1072-4WL...	45	68	VPM 120	60	6SL312 ■ - 1 TE26-0AA3
1FE1072-4WH...	64	96	VPM 120	85	6SL312 ■ - 1 TE28-5AA3
1FE1073-4WN...	65	97	VPM 120	85	6SL312 ■ - 1 TE28-5AA3
1FE1073-4WT...	30	44	VPM 120	45	6SL312 ■ - 1 TE24-5AA3
1FE1074-4WN...	91	136	VPM 120	132	6SL312 ■ - 1 TE31-3AA3
1FE1074-4WM...	97	144	VPM 120	132	6SL312 ■ - 1 TE31-3AA3
1FE1074-4WT...	53	77	VPM 120	60	6SL312 ■ - 1 TE26-0AA3
1FE1082-4WN...	42	60	VPM 120	45	6SL312 ■ - 1 TE24-5AA3
1FE1082-4WR...	24	34	VPM 120	30	6SL312 ■ - 1 TE23-0AA3
1FE1083-4WN...	77	110	VPM 120	85	6SL312 ■ - 1 TE28-5AA3
1FE1084-4WN...	105	150	VPM 120	132	6SL312 ■ - 1 TE31-3AA3
1FE1084-4WP...	79	120	VPM 120	132	6SL312 ■ - 1 TE31-3AA3
1FE1084-4WQ...	83	119	VPM 120	85	6SL312 ■ - 1 TE28-5AA3
1FE1084-4WT...	84	110	VPM 120	85	6SL312 ■ - 1 TE28-5AA3
1FE1085-4WN...	105	150	VPM 120	132	6SL312 ■ - 1 TE31-3AA3
1FE1085-4WT...	60	85	VPM 120	60	6SL312 ■ - 1 TE26-0AA3
1FE1085-4WQ...	85	120	VPM 120	85	6SL312 ■ - 1 TE28-5AA3

Cooling:

Internal air cooling
External air cooling

0
1

Motor Module:

Single Motor Module
Double Motor Module

1
2

- 1) Data for $\Delta T = 105$ K, special windings on request.
- 2) Standard scope of supply: Encapsulated winding with 2xKTY (1 spare).
- 3) Stator without cooling jacket, with impregnated winding on request.
- 4) Ordering spare parts: Stator: 1FE1...-.....-2.W.
- 5) Ordering spare parts: Rotor: 1FE1...-.....-3W..
- 6) Full protection option, application example: Load at motor standstill, external tripping unit required: Order No. 3RN1013-1GW10.
- 7) Universal protection option: Full protection + NTC PT3-51F + NTC K227.
- 8) Series reactor required, see Configuration Manual.
- 9) For cable design, see Configuration Manual
- 10) Power section with integrated VPM available soon.

Synchronous motors

Main spindle motors for SINAMICS S120

1FE1 standard type built-in motors

Water cooling

Selection and Ordering Data

Rated power for duty type in accordance with IEC 60034-1 ¹⁾		Rated torque ¹⁾		Rated speed	Speed, max.	1FE1 built-in motors Water cooling	Moment of inertia of rotor	Weight (rotor and stator), approx.		
P_{rated}	S6-40%	M_{rated}	S6-40%	n_{rated}	n_{max}				Order No.	J
kW (HP)	kW (HP)	Nm (lb _f -in)	Nm (lb _f -in)	rpm	rpm					kgm ² (lb _f -in-s ²)

High-Speed series, 4-pole

16 (21)	16 (21)	45 (398)	60 (531)	3400	18000	1FE1092-4WP ■ 1- 1 B ■ ■ ■	0.00916 (0.0811)	30 (66.2)
10.5 (14.1)	10.5 (14.1)	24 (443)	35 (310)	2000	10000	1FE1092-4WV ■ 1- 1 B ■ ■ ■	0.00916 (0.0811)	30 (66.2)
27.5 (36.9)	27.5 (36.9)	64 (310)	92 (814)	3500	18000	1FE1093-4WM ■ 1- 1 B ■ ■ ■	0.01694 (0.1499)	43.5 (95.9)
26 (35)	26 (35)	75 (664)	103 (912)	3300	16000	1FE1093-4WN ■ 1- 1 B ■ ■ ■	0.01694 (0.1499) ⁹⁾	43.5 (95.9)
35 (47)	35 (47)	75 (664)	103 (912)	4500	18000	1FE1093-4WH ■ 1- 1 B ■ ■ ■	0.01694 (0.1499) ⁹⁾	43.5 (95.9)
40 (54)	40 (54)	100 (885)	137 (1213)	3800	18000	1FE1094-4WL ■ 1- 1 B ■ ■ ■	0.02168 (0.1919) ⁹⁾	50.5 (111)
46 (62)	46 (62)	100 (885)	137 (1213)	4400	18000	1FE1094-4WK ■ 1- 1 B ■ ■ ■	0.02168 (0.1919) ⁹⁾	50.5 (111)
26 (35)	26 (35)	100 (885)	125 (1106)	2500	13000	1FE1094-4WS ■ 1- 1 B ■ ■ ■	0.02168 (0.1919) ⁹⁾	50.5 (111)
18 (24)	18 (24)	95 (841)	118 (1044)	1800	10000	1FE1094-4WU ■ 1- 1 B ■ ■ ■	0.02168 (0.1919)	50.5 (111)
46 (62)	46 (62)	125 (1106)	170 (1505)	3500	18000	1FE1095-4WN ■ 1- 1 B ■ ■ ■	0.02642 (0.2338) ⁹⁾	59 (130)
52 (70)	52 (70)	150 (1328)	206 (1823)	3300	16000	1FE1096-4WN ■ 1- 1 B ■ ■ ■	0.03140 (0.2779) ⁹⁾	67 (148)
38.5 (51.6)	45 (60)	102 (903)	142 (1257)	3600	16000	1FE1103-4WN ■ 1- 1 B A ■ ■	0.01589 (0.1406)	34 (75)
54 (72)	64 (86)	136 (1204)	190 (1682)	3800	16000	1FE1104-4WN ■ 1- 1 B A ■ ■	0.02098 (0.1857)	42.5 (93.7)
53.4 (71.6)	64 (86)	170 (1505)	236 (2089)	3000	16000	1FE1105-4WN ■ 1- 1 B A ■ ■	0.02609 (0.2309)	52 (115)
72.6 (97.3)	85 (114)	204 (1806)	283 (2505)	3400	16000	1FE1106-4WN ■ 1- 1 B A ■ ■	0.03147 (0.2785)	61.5 (136)
62 (83)	66 (89)	204 (1806)	270 (2390)	2900	14000	1FE1106-4WR ■ 1- 1 B A ■ ■	0.03147 (0.2785)	61.5 (136)
56.5 (75.7)	60 (80)	200 (1770)	270 (2390)	2700	12500	1FE1106-4WS ■ 1- 1 B A ■ ■	0.03147 (0.2785)	61.5 (136)
25 (34)	30 (40)	200 (1770)	270 (2390)	1200	6000	1FE1106-4WY ■ 1- 1 B A ■ ■	0.03147 (0.2785)	61.5 (136)
63 (85)	75 (101)	200 (1770)	275 (2434)	3000	14000	1FE1124-4WN ■ 1- 1 B A ■ ■	0.05112 (0.4524)	62.6 (138)
78.5 (105.2)	90 (121)	250 (2213)	345 (3054)	3000	14000	1FE1125-4WN ■ 1- 1 B A ■ ■	0.06337 (0.5608)	76 (168)
65.5 (87.8)	82 (110)	250 (2213)	345 (3054)	2500	12500	1FE1125-4WP ■ 1- 1 B A ■ ■	0.06337 (0.5608)	76 (168)
94 (126)	112 (150)	300 (2655)	410 (3629) ²⁾	3000	14000	1FE1126-4WN ■ 1- 1 B A ■ ■	0.07604 (0.6729)	90 (198)
78.5 (105.2)	100 (134)	300 (2655)	410 (3629) ²⁾	2500	12500	1FE1126-4WP ■ 1- 1 B A ■ ■	0.07604 (0.6729)	90 (198)
63 (85)	82 (110)	300 (2655)	410 (3629)	2000	10000	1FE1126-4WQ ■ 1- 1 B A ■ ■	0.07604 (0.6729)	90 (198)

- Standard protection: 2xKTY³⁾
- Full protection: 2xKTY + 3xPTC thermistor drilling⁷⁾
- Universal protection⁸⁾

1
3
5

- Delivery of stator + rotor³⁾⁵⁾⁶⁾

1

- Stator with cooling jacket³⁾⁴⁾

B

- Without rotor sleeve
- Without rotor sleeve, $d_i = 80$ mm (3.15 in) for 1FE109.-4W... only

A

R

- Free cable ends, 1.5 m (4.92 ft) in length¹⁰⁾
Cable outlet at larger outer diameter of cooling jacket
Cable outlet at smaller outer diameter of cooling jacket (on request)
- Free cable ends, flexible, 0.5 m (1.64 ft) in length (preferred variant)
Cable outlet at larger outer diameter of cooling jacket
Cable outlet at smaller outer diameter of cooling jacket (on request)

0

1

2

3

S1 = continuous duty
S6 = intermittent duty:
Sizes 50 and 70: Duty cycle time 1 min
Sizes 80 to 120: duty cycle time 2 min

Synchronous motors

Main spindle motors for SINAMICS S120

1FE1 standard type built-in motors
Water cooling

Selection and Ordering Data

Motor type (continued)	Rated current for duty type in accordance with IEC 60034-1 ¹⁾		Voltage Protection Module ¹⁾	SINAMICS S120 Motor Module	
	I_{rated}	S6-40%		Required rated current	Booksiz format
	S1	S6-40%		I_{rated}	Order No.
	A	A		S1	
				A	

High-Speed series, 4-pole

1FE1092-4WP...	41	58	VPM 120	45	6SL312 ■ - 1 TE24-5AA3
1FE1092-4WV...	24	25	VPM 120	30	6SL312 ■ - 1 TE23-0AA3
1FE1093-4WM...	64	92	VPM 120	85	6SL312 ■ - 1 TE28-5AA3
1FE1093-4WN...	60	86.4	VPM 120	60	6SL312 ■ - 1 TE26-0AA3
1FE1093-4WH...	83	120	VPM 120	132	6SL312 ■ - 1 TE31-3AA3
1FE1094-4WL...	90	130	VPM 120	132	6SL312 ■ - 1 TE31-3AA3
1FE1094-4WK...	108	156	VPM 120	132	6SL312 ■ - 1 TE31-3AA3
1FE1094-4WS...	60	85	VPM 120	60	6SL312 ■ - 1 TE26-0AA3
1FE1094-4WU...	45	64	VPM 120	45	6SL312 ■ - 1 TE24-5AA3
1FE1095-4WN...	108	156	VPM 120	132	6SL312 ■ - 1 TE31-3AA3
1FE1096-4WN...	120	173	VPM 120	132	6SL312 ■ - 1 TE31-3AA3
1FE1103-4WN...	84	127	VPM 120	85	6SL312 ■ - 1 TE28-5AA3
1FE1104-4WN...	120	181	VPM 200	132	6SL312 ■ - 1 TE31-3AA3
1FE1105-4WN...	120	180	VPM 200	132	6SL312 ■ - 1 TE31-3AA3
1FE1106-4WN...	159	240	VPM 200	200	6SL312 ■ - 1 TE32-0AA3
1FE1106-4WR...	128	184	VPM 200	200	6SL312 ■ - 1 TE32-0AA3
1FE1106-4WS...	120	170	VPM 200	132	6SL312 ■ - 1 TE31-3AA3
1FE1106-4WY...	60	85	VPM 120	60	6SL312 ■ - 1 TE26-0AA3
1FE1124-4WN...	135	198	VPM 200	200	6SL312 ■ - 1 TE32-0AA3
1FE1125-4WN...	162	240	VPM 200	200	6SL312 ■ - 1 TE32-0AA3
1FE1125-4WP...	147	215	VPM 200	200	6SL312 ■ - 1 TE32-0AA3
1FE1126-4WN...	200	295 ²⁾	VPM 200	200	6SL312 ■ - 1 TE32-0AA3
1FE1126-4WP...	180	265 ²⁾	VPM 200	200	6SL312 ■ - 1 TE32-0AA3
1FE1126-4WQ...	147	215	VPM 200	200	6SL312 ■ - 1 TE32-0AA3

Cooling:

Internal air cooling
External air cooling

0
1

Motor Module:

Single Motor Module

1

- 1) Data for $\Delta T = 105$ K, special windings on request.
- 2) Observe limit for power section.
- 3) Standard scope of supply: Encapsulated winding with 2xKTY (1 spare).
- 4) Stator without cooling jacket, with impregnated winding on request.
- 5) Ordering spare parts: Stator: 1FE1...-.....-2.W.
- 6) Ordering spare parts: Rotor: 1FE1...-.....-3W..
- 7) Full protection option, application example: Load at motor standstill, external tripping unit required: Order No. 3RN1013-1GW10.
- 8) Universal protection option: Full protection + NTC PT3-51F + NTC K227.
- 9) For moment of inertia for version "R" without rotor jacket $d_f = 80$ mm (3.15 in), see Configuration Manual.
- 10) For cable design, see Configuration Manual.
- 11) Power section with integrated VPM available soon.

Synchronous motors

Main spindle motors for SINAMICS S120

1FE1 built-in motors

Dimension drawing

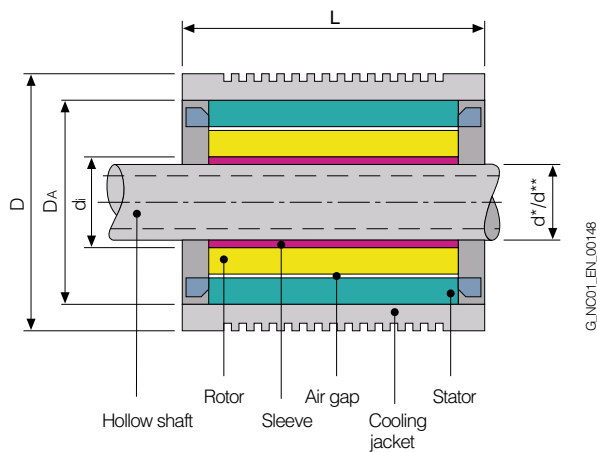

1FE1 motor Type	L mm (in)	D mm (in)	DA mm (in)	di mm (in)
High-Speed series				
1FE1051-4...-1BA.	130 (5.12)	120 (4.72)	106 (4.17)	46 (1.81)
1FE1052-4...-1BA.	180 (7.09)	120 (4.72)	106 (4.17)	46 (1.81)
1FE1053-4...-1BA.	230 (9.06)	120 (4.72)	106 (4.17)	46 (1.81)
1FE1072-4W...-1BA.	185 (7.28)	155 (6.10)	135 (5.31)	58 (2.28)
1FE1073-4W...-1BA.	235 (9.25)	155 (6.10)	135 (5.31)	58 (2.28)
1FE1074-4W...-1BA.	285 (11.2)	155 (6.10)	135 (5.31)	58 (2.28)
1FE1082-4W...-1BA.	190 (7.48)	180 (7.09)	160 (6.30)	68 (2.68)
1FE1083-4W...-1BA.	240 (9.45)	180 (7.09)	160 (6.30)	68 (2.68)
1FE1084-4W...-1BA.	290 (11.4)	180 (7.09)	160 (6.30)	68 (2.68)
1FE1085-4W...-1BA.	340 (13.4)	180 (7.09)	160 (6.30)	68 (2.68)
1FE1092-4W...-1BR.	200 (7.87)	205 (8.07)	180 (7.09)	80 (3.15)
1FE1093-4W...-1BA.	250 (9.84)	205 (8.07)	180 (7.09)	72 (2.83)
1FE1093-4W...-1BR.	250 (9.84)	205 (8.07)	180 (7.09)	80 (3.15)
1FE1094-4W...-1BA.	300 (11.8)	205 (8.07)	180 (7.09)	72 (2.83)
1FE1094-4W...-1BR.	300 (11.8)	205 (8.07)	180 (7.09)	80 (3.15)
1FE1095-4W...-1BA.	350 (13.8)	205 (8.07)	180 (7.09)	72 (2.83)
1FE1095-4W...-1BR.	350 (13.8)	205 (8.07)	180 (7.09)	80 (3.15)
1FE1096-4W...-1BA.	400 (15.7)	205 (8.07)	180 (7.09)	72 (2.83)
1FE1096-4W...-1BR.	400 (15.7)	205 (8.07)	180 (7.09)	80 (3.15)
1FE1103-4W...-1BA.	265 (10.4)	230 (9.06)	200 (7.87)	96 (3.78)
1FE1104-4W...-1BA.	315 (12.4)	230 (9.06)	200 (7.87)	96 (3.78)
1FE1105-4W...-1BA.	365 (14.4)	230 (9.06)	200 (7.87)	96 (3.78)
1FE1106-4W...-1BA.	415 (16.3)	230 (9.06)	200 (7.87)	96 (3.78)
1FE1124-4W...-1BA.	315 (12.4)	270 (10.6)	240 (9.45)	110 (4.33)
1FE1125-4W...-1BA.	365 (14.4)	270 (10.6)	240 (9.45)	110 (4.33)
1FE1126-4W...-1BA.	415 (16.3)	270 (10.6)	240 (9.45)	110 (4.33)

Rotors of the High-Speed series are supplied without rotor sleeve and unbalanced.

1FE1 motor Type	L mm (in)	D mm (in)	DA mm (in)	di mm (in)	Internal rotor diameter with sleeve				
					d* mm (in)	d** mm (in)	d** mm (in)	d** mm (in)	d** mm (in)
High-Torque series									
1FE1041-6W...-1BA.	107 (4.21)	95 (3.74)	85 (3.35)	44 (1.73)	-	-	-	-	-
1FE1042-6W...-1BA.	157 (6.20)	95 (3.74)	85 (3.35)	44 (1.73)	-	-	-	-	-
1FE1051-6W...-1B..	170 (6.69)	115 (4.53)	103.5 (4.07)	42 (1.65)	-	33 (1.30)	-	-	-
1FE1052-6W...-1B..	220 (8.66)	115 (4.53)	103.5 (4.07)	42 (1.65)	-	33 (1.30)	-	-	-
1FE1054-6W...-1BA.	320 (12.6)	115 (4.53)	103.5 (4.07)	42 (1.65)	-	-	-	-	-
1FE1061-6W...-1B..	130 (5.12)	130 (5.12)	118 (4.65)	58 (2.28)	48 (1.89)	-	-	-	-
1FE1064-6W...-1BA.	280 (11.0)	130 (5.12)	118 (4.65)	58 (2.28)	-	-	-	-	-
1FE1082-6W...-1B..	195 (7.68)	190 (7.48)	170 (6.69)	93 (3.66)	67 (2.64)	74 (2.91)	80 (3.15)	-	-
1FE1084-6W...-1B..	295 (11.6)	190 (7.48)	170 (6.69)	93 (3.66)	-	74 (2.91)	-	-	-
1FE1091-6W...-1B..	150 (5.91)	205 (8.07)	180 (7.09)	92 (3.62)	67 (2.64)	80 (3.15)	-	-	-
1FE1092-6W...-1B..	200 (7.87)	205 (8.07)	180 (7.09)	92 (3.62)	67 (2.64)	80 (3.15)	-	-	-
1FE1093-6W...-1B..	250 (9.84)	205 (8.07)	180 (7.09)	92 (3.62)	67 (2.64)	80 (3.15)	-	-	-
1FE1113-6W...-1B..	260 (10.2)	250 (9.84)	220 (8.66)	120 (4.72)	-	-	80 (3.15)	105.2 (4.14)	-
1FE1114-6W...-1B..	310 (12.2)	250 (9.84)	220 (8.66)	120 (4.72)	82 (3.23)	102 (4.02)	-	-	-
1FE1115-6W...-1B..	360 (14.2)	250 (9.84)	220 (8.66)	120 (4.72)	-	102 (4.02)	-	-	-
1FE1116-6W...-1B..	410 (16.1)	250 (9.84)	220 (8.66)	120 (4.72)	82 (3.23)	102 (4.02)	-	-	-
1FE1144-8W...-1BA.	340 (13.4)	310 (12.2)	280 (11.0)	166.7 (6.56)	-	-	-	-	-
1FE1145-8W...-1BC.	390 (15.3)	310 (12.2)	280 (11.0)	-	-	150.3 (5.92)	-	-	-
1FE1147-8W...-1BC.	490 (19.3)	310 (12.2)	280 (11.0)	-	-	150.3 (5.92)	-	-	-

Note:

Rotors without rotor sleeve "-.A." are supplied without pre-balancing. Rotors with rotor sleeve "-.B./-.C./-.D./-.E." are supplied pre-balanced.

Synchronous motors

Main spindle motors for SINAMICS S120

VPM Voltage Protection Module

Overview

The VPM is used with motors 1FE1...-...1-.... and 2SP1 with EMF of $\hat{U} > 800 \text{ V}$ to 2000 V (U_{eff} 570 V to 1400 V) to limit the DC link voltage at the converter in the event of a fault. If the line voltage fails at maximum motor speed or if the drive converter pulses are canceled as a result of the power failure, the synchronous motor regenerates at high voltage back into the DC link.

The VPM detects a DC link voltage that is too high ($> 800 \text{ V DC}$) and short-circuits the three motor supply cables. The power remaining in the motor is converted to heat via the short circuit in the VPM and motor.

The VPM can withstand short-circuit braking a number of times.

Integration

The VPM is only operational in conjunction with SINAMICS S120 and 1FE1/2SP1 motors.

The VPM must be installed between motor and drive system (at a maximum distance from the drive system of 1.5 m (4.92 ft)). 6FX8 shielded motor supply cables must be used in combination with the VPM.

System requirements for operating 1FE1/2SP1 motors:

- SINAMICS S120
- SINUMERIK 840D sl SW version 1.3 and higher

Technical specifications

Product name	Voltage Protection Module		
	VPM 120	VPM 200	VPM 200 DYNAMIK
Degree of protection in accordance with EN 60529 (IEC 60529)	IP20		
Humidity rating based on EN 60721-3-3	Class 3K5, condensation and icing excluded. Low air temperature 0 °C (32 °F)		
Ambient temperature			
• Storage	-25 ... +55 °C (-13 ... +131 °F)		
• Transport	-25 ... +55 °C (-13 ... +131 °F)		
• Operation	0 ... 55 °C (32 ... 131 °F)		
Dimensions			
• Height	300 mm (11.8 in)	300 mm (11.8 in)	300 mm (11.8 in)
• Width	150 mm (5.91 in)	250 mm (9.84 in)	250 mm (9.84 in)
• Depth	180 mm (7.09 in)	190 mm (7.48 in)	260 mm (10.2 in)
Weight, approx.	6 kg (13.2 lb)	11 kg (24.3 lb)	12 kg (26.5 lb)

Selection and Ordering Data

Designation	Order No.
Voltage Protection Module	
• VPM 120 (120 A)	6SN1113-1AA00-1JA1
• VPM 200 (200 A)	6SN1113-1AA00-1KA1
• VPM 200 DYNAMIK (200 A) for large conductor cross-sections (up to 50 mm ²) and for non-Siemens synchronous motors	6SN1113-1AA00-1KC1

Synchronous motors

Motor spindles for SINAMICS S120

2SP1 ECS standard type motor spindles Water cooling

Overview



The 2SP1 ECS motor spindle product range comprises compact standard motor spindles for milling machines that can be used as an alternative to belt-driven spindles and can be used both for rough cutting and for precise fine machining.

The 2SP1 motor spindle contains all the classical elements of a motor spindle, such as a tool interface, tool clamping and release mechanism, spindle bearings suitable for absorbing the machining forces, water-cooled drive motor, spindle casing for fixing and sensors for indexing and monitoring tool changeover.

The motorized spindles are available in 2 diameters of 200 mm (7.87 in) (2SP120) and 250 mm (9.84 in) (2SP125) and are offered with different torque and speed graduations to match the respective milling machine family. The motor spindles are ideally matched to the performance levels of SINAMICS S120.

The complete product range of 2SP1 motor spindles was developed in cooperation with and is manufactured at Weiss Spindeltechnologie GmbH.

Benefits

The 2SP1 ECS motor spindles offer the user the following important advantages over conventional belt-driven solutions:

- Compact spindle solution and "everything included" in the spindle box
- Fewer components and easy installation
- Economical standard solution as compared with today's belt-driven solutions
- Drive train with high degree of rigidity
- High torque and speed and therefore high productivity thanks to high cutting efficiency and reduction of non-productive time
- Higher speed and shorter start-up times as compared with conventional belt-driven or gear solutions
- Economical pneumatic tool release mechanism or optional fast hydraulic tool release mechanism
- Worldwide system delivery including spindle mechanics from a single source – from Siemens
- Extremely short tool change times with 2SP210 thanks to 2-channel technology and clamping set with optional latching capability

Application

The main application area for 2SP1 ECS motor spindles are main spindles for simple milling machines and machining centers in the job shop area of the machine tools sector.

The 2SP120 motor spindles are particularly suitable for the area of light metal machining at low torque and high speeds.

The 2SP125 motor spindles are characterized by a high torque. The main area of application is in the machining of steel and castings.

Design

The 2SP1 ECS motor spindles are characterized by a rugged design.

Depending on the version, the following options are available for 2SP1 ECS motor spindles:

- Various tool interfaces
- Internal tool cooling
- External tool cooling

Synchronous motors

Motor spindles for SINAMICS S120

2SP1 ECS standard type motor spindles
Water cooling

Integration

The 2SP1 ECS motor spindle can generally be used with:

- SINAMICS S120
- SINUMERIK 802D sl
- SINUMERIK 840Di sl
- SINUMERIK 840D sl

A VPM 120 Voltage Protection Module must be used with ECS motor spindles in synchronous design, see 1FE1 built-in motors.

Characteristics

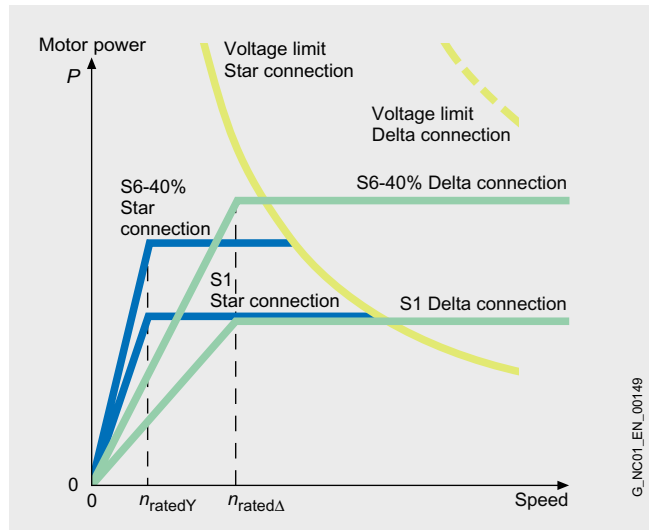

2SP1 ECS motor spindles in asynchronous design with star-delta changeover

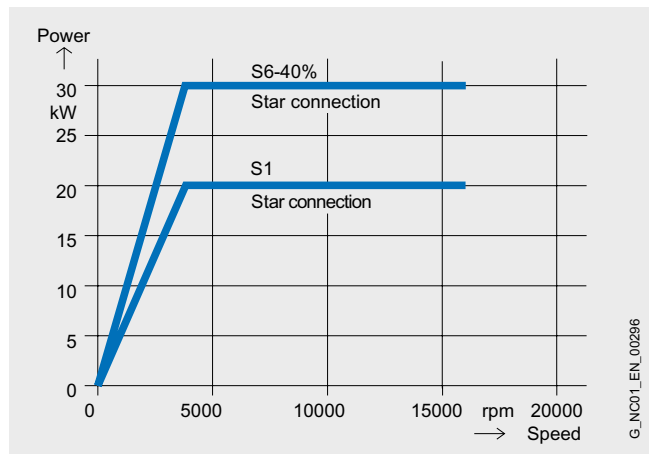

2SP1 ECS motor spindles in synchronous design

Synchronous motors

Motor spindles for SINAMICS S120

2SP1 ECS standard type motor spindles Water cooling

Technical specifications

Product name	2SP120 ECS motor spindles	2SP125 ECS motor spindles
Standard functions		
Enclosure	Cartridge with flange mounting	Cartridge with flange mounting
Working position	Horizontal/vertical	Horizontal/vertical
Tool holder	HSK A63	SK 40 for tools with asymmetrical T sliding blocks
Tool clamping device	Release using pneumatic cylinder, 6 bar Clamping using cup-spring assembly	Release using pneumatic cylinder, 6 bar Clamping using cup-spring assembly
Speed, max.	15000 rpm	10000 rpm
Bearing lubrication	Grease, permanent lubrication	Grease, permanent lubrication
Seal, bearing front	Sealing air 1 to 1.5 m ³ /h, filter grade 8 µm	Sealing air 1 to 1.5 m ³ /h, filter grade 8 µm
Tool taper cleaning	Compressed air through draw-bar 5 to 6 bar	Compressed air through draw-bar 5 to 6 bar
Insulation of the stator winding in accordance with EN 60034-1 (IEC 60034-1)	Temperature class 155 (F) for a coolant inlet temperature of 25 °C (77 °F)	Temperature class 155 (F) for a coolant inlet temperature of 25 °C (77 °F)
Degree of protection in accordance with IEC 60034-5	IP64 (in working area) IP53 (behind the spindle flange)	IP64 (in working area) IP53 (behind the spindle flange)
Recommended coolant inlet temperature, approx.	25 °C (77 °F) (depending on the ambient temperature)	25 °C (77 °F) (depending on the ambient temperature)
Measuring system	Hollow-shaft measuring system, incremental, sin/cos 1 V _{pp} 256 S/R with zero mark	Hollow-shaft measuring system, incremental, sin/cos 1 V _{pp} 256 S/R with zero mark
Standard protection – temperature monitoring	<ul style="list-style-type: none"> • Motor thermal sensor KTY84-130 • PTC for full thermal protection • NTC PT3-51F • NTC K227 	<ul style="list-style-type: none"> • Motor thermal sensor KTY84-130 • PTC for full thermal protection • NTC PT3-51F • NTC K227
Clamping status monitoring	Sensors (analog) <ul style="list-style-type: none"> • Tool clamped • Draw-bar in the release position • Clamped without tool Sensors (digital) <ul style="list-style-type: none"> • Position of release piston 	Sensors (digital) <ul style="list-style-type: none"> • Tool clamped¹⁾ • Draw-bar in the release position • Clamped without tool
Cooling with water	<ul style="list-style-type: none"> • max. 5 bar, 10 l/min • max. 25% corrosion protection agent Clariant Antifrogen N or Tyfocor • Filter grade 100 µm 	<ul style="list-style-type: none"> • max. 5 bar, 10 l/min • max. 25% corrosion protection agent Clariant Antifrogen N or Tyfocor • Filter grade 100 µm
Connections for the media	<ul style="list-style-type: none"> • Cooling • Sealing air • Air purge • Release tool • Clamp tool 2 x hose plug-in connector, Ø 12/10 mm (0.47/0.39 in) 1 x G 1/8 radial/Ø 5 mm (0.20 in) axial 1 x G 1/4 1 x G 1/4 1 x G 1/8	2 x G 1/2 (Ø 9 mm (0.35 in)) 1 x G 1/8 (Ø 8 mm (0.31 in)) 1 x G 1/4 1 x M16x1.5 1 x G 1/8
Electrical connections	<ul style="list-style-type: none"> • Power through cable 1.5 m (4.92 ft) • Sensors through signal plug 	<ul style="list-style-type: none"> • Power through cable 1.5 m (4.92 ft) • Sensors through signal plug

¹⁾ For manual tool changing; additional sensors are required for automatic tool changing (see Options).

Synchronous motors

Motor spindles for SINAMICS S120

2SP1 ECS standard type motor spindles
Water cooling

Technical specifications

Product name	2SP120 ECS motor spindles	2SP125 ECS motor spindles
Options		
Internal tool cooling	<ul style="list-style-type: none"> • 50 bar, up to 54 l/min • Filter grade 50 µm according to -/16/13 ISO 4406 • 1 x G1/4 coolant • 1 x G1/8 leakage 	<ul style="list-style-type: none"> • 50 bar, up to 54 l/min • Filter grade 50 µm according to -/16/13 ISO 4406 • 1 x G1/4 coolant • 1 x G1/8 leakage
External tool cooling	<ul style="list-style-type: none"> • Ring with 6 adjustable nozzles • 5 bar • Filter grade 50 µm according to -/16/13 ISO 4406 	–
Increased max. speed	18000 rpm	15000 rpm (with HSK A63)
Tool clamping device	<ul style="list-style-type: none"> • Release using hydraulic cylinder, 80 bar • Clamping using cup-spring assembly • 1 x G 1/4, release tool • 1 x G 1/4, clamp tool 	–
Tool interface	–	BT 40, CAT 40, HSK A63

Synchronous motors

Motor spindles for SINAMICS S120

2SP1 ECS standard type motor spindles Water cooling

Selection and Ordering Data

Spindle diameter	Rated power Star/delta		Rated torque Star/delta		Rated speed Star/delta	Maximum speed	2SP1 ECS motor spindles Water cooling
	P_{rated} S1	S6-40%	M_{rated} S1	S6-40%	n_{rated}	n_{max}	
mm (in)	kW (HP)	kW (HP)	Nm (lb _f -in)	Nm (lb _f -in)	rpm	rpm	Order No. Standard type
Synchronous							
200	12.0/- (16.1/-)	12.0/- (16.1/-)	42/- (372/-)	55/- (487/-)	2700/-	15000	2SP1202-1HA ■ ■ -1 D ■ ■
	15.5/- (20.8/-)	15.5/- (20.8/-)	42/- (372/-)	55/- (487/-)	3500/-	18000	2SP1202-1HB ■ ■ -2 D ■ ■
	26.4/- (35.4/-)	26.4/- (35.4/-)	84/- (744/-)	110/- (974/-)	3000/-	15000	2SP1204-1HA ■ ■ -1 D ■ ■
	35.0/- (46.9/-)	35.0/- (46.9/-)	78/- (690/-)	110/- (974/-)	4300/-	18000	2SP1204-1HB ■ ■ -2 D ■ ■
Asynchronous							
250	13.2/13.2 (17.7/17.7)	18.9/18.9 (25.3/25.3)	70/32 (620/283)	100/45 (885/398)	1800/4000	10000	2SP1253-8HA 0 ■ -0 ■ ■ 2
	13.2/13.2 (17.7/17.7)	18.9/18.9 (25.3/25.3)	70/32 (620/283)	100/45 (885/398)	1800/4000	15000	2SP1253-8HA 0 ■ -1 D ■ 2
	11.7/11.7 (15.7/15.7)	16.7/16.7 (22.4/22.4)	140/62 (1239/549)	200/89 (1170/788)	800/1800	10000	2SP1255-8HA 0 ■ -0 ■ ■ 2
	11.7/11.7 (15.7/15.7)	16.7/16.7 (22.4/22.4)	140/62 (1239/549)	200/89 (1170/788)	800/1800	15000	2SP1255-8HA 0 ■ -1 D ■ 2
Synchronous							
250	26.0/- (34.9/-)	29.0/- (38.9/-)	100/- (885/-)	130/- (1151/-)	2500/-	10000	2SP1253-1HA 0 ■ -0 ■ ■ 2
	35.0/- (46.9/-)	38.0/- (50.9/-)	100/- (885/-)	130/- (1151/-)	3300/-	15000	2SP1253-1HB 0 ■ -1 D ■ 2
	46.3/- (62.1/-)	55.0/- (73.7/-)	170/- (1505/-)	236/- (2089/-)	2600/-	10000	2SP1255-1HA 0 ■ -0 ■ ■ 2
	53.4/- (71.6/-)	64.0/- (85.8/-)	170/- (1505/-)	236/- (2089/-)	3000/-	15000	2SP1255-1HB 0 ■ -1 D ■ 2
Tool clamping and release mechanism:							
Pneumatic (<u>only</u> for 2SP125)							0
Pneumatic (<u>only</u> for 2SP120)							2
Hydraulic (<u>only</u> for 2SP120)							3
Cooling:							
Closed cooling jacket							1
Closed cooling jacket and internal tool cooling							3
Closed cooling jacket and ring for external tool cooling (<u>only</u> for 2SP120)							4
Closed cooling jacket, internal tool cooling and ring for external tool cooling (<u>only</u> for 2SP120)							5
Tool interfaces:							
Tool interface SK 40							A B C D E R
Tool interface BT 40 45°							
Tool interface CAT 40							
Tool interface HSK A63							
Tool interface BT 40 30°							
Tool interface HSK A63, latching (<u>only</u> for 2SP120)							
Sensors:							
"Tool clamped" sensor, "draw-bar in the release position" sensor and "clamped without tool" sensor							D F
D + "position of release piston" sensor (<u>only</u> for 2SP120)							
Type of connection:							
Permanently connected cable, sensor cable with signal connector, length: 1.5 m (4.92 ft)							2 6
Power cable with open core ends							
Power cable with connector (2SP1202: Connector size 1.5/2SP1204: Connector size 3)							

Synchronous motors

Motor spindles for SINAMICS S120

2SP1 ECS standard type motor spindles
Water cooling

Selection and Ordering Data

Motor type (continued)	Moment of inertia J kgm ² (lb _r -in-s ²)	Weight, ¹⁾ approx. m kg (lb)	Rated current Star/delta		Voltage Protection Module	SINAMICS S120 Motor Module	
			I_{rated} S1 A	S6-40% A		Required rated current I_{rated} S1 A	Booksized format Order No.
Synchronous							
2SP1202-1HA...	0.015 (0.1327)	83 (183)	30/-	43/-	VPM 120	30	6SL312 - 1 TE23-0AA3
2SP1202-1HB...	0.015 (0.1327)	83 (183)	42/-	60/-	VPM 120	45	6SL312 - 1 TE24-5AA3
2SP1204-1HA...	0.023 (0.2035)	101 (223)	60/-	85/-	VPM 120	60	6SL312 - 1 TE26-0AA3
2SP1204-1HB...	0.023 (0.2035)	101 (223)	79/-	120/-	VPM 120	85	6SL312 - 1 TE28-5AA3
Asynchronous							
2SP1253-8HA0.-0...	0.037 (0.3274)	130 (287)	28/29	39/39	-	30	6SL312 - 1 TE23-0AA3
2SP1253-8HA0.-1...	0.037 (0.3274)	130 (287)	28/29	39/39	-	30	6SL312 - 1 TE23-0AA3
2SP1255-8HA0.-0...	0.055 (0.4867)	165 (364)	30/29	40/37	-	30	6SL312 - 1 TE23-0AA3
2SP1255-8HA0.-1...	0.055 (0.4867)	165 (364)	30/29	40/37	-	30	6SL312 - 1 TE23-0AA3
Synchronous							
2SP1253-1HA...	0.037 (0.3274)	130 (287)	53/-	75/-	VPM 120	60	6SL312 - 1 TE26-0AA3
2SP1253-1HB...	0.037 (0.3274)	130 (287)	68/-	98/-	VPM 120	85	6SL312 - 1 TE28-5AA3
2SP1255-1HA...	0.055 (0.4867)	165 (364)	95/-	135/-	VPM 120	132	6SL312 - 1 TE31-3AA3
2SP1255-1HB...	0.055 (0.4867)	165 (364)	120/-	180/-	VPM 120	132	6SL312 - 1 TE31-3AA3
Cooling:							
Internal air cooling						0	
External air cooling						1	
Motor Module:							
Single Motor Module							1

More information

Please refer to Asynchronous motors – Liquid cooling for a list of heat exchanger manufacturers.

In addition to the standard motor spindles in the 2SP1 product range, it is also possible to use individually customized motor spindle designs.

For information about other motor spindles for turning, grinding, milling and drilling, please contact:

Weiss Spindeltechnologie GmbH

– a Siemens Company –
Rudolf-Diesel-Str. 35
97424 SCHWEINFURT, Germany

Phone: +49 (0)97 21 - 77 01 - 10
Fax: +49 (0)97 21 - 77 01 - 13 3

More information is available on the Internet at









<http://www.weissgmbh.de>

¹⁾ No options included.
Internal tool cooling: + 1 kg (2.21 lb)
External tool cooling: + 8 kg (17.6 lb).

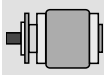
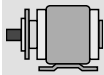
Synchronous motors

Selection guides

Type/mounting position

Type/ mounting position	Designa- tion	Type/ mounting position	Designa- tion	Type/ mounting position	Designa- tion
	IM B3		IM B5 IM B14		IM B35
	IM V5		IM V1 IM V18		IM V15
	IM V6		IM V3 IM V19		IM V35

Degree of protection

The degree of protection designation in accordance with EN 60034-5 (IEC 60034-5) is made using the letters "IP" and two digits (e.g., IP64). The second digit in the degree of protection designation represents the protection against water, the first digit the protection against penetration of foreign matter.

Since coolants used for machine tools and transfer machines usually contain oil, are able to creep, and may also be corrosive, protection against water alone is insufficient. The indicated degree of protection should only be considered here as a guideline. The motors must be protected by suitable covers. Attention must be paid to providing suitable sealing of the motor shaft for the selected degree of protection for the motor.

The table can serve as a decision aid for selecting the proper degree of protection for motors. For a mounting position with vertical shaft end IM V3/IM V19, static fluid on the flange is only permitted with degree of protection IP67/IP68 and recessed DE flange in some cases.

	Liquids	General work- shop environ- ment	Water; gen. coolant (95% water, 5% oil); oil	Creep oil; petroleum; aggressive coolants
Effect				
Dry		IP64	–	–
Water-enriched environment		–	IP64	IP67 ¹⁾
Mist		–	IP65	IP67
Spray		–	IP65	IP68
Jet		–	IP67	IP68
Surge, brief immersion; constant inundation		–	IP67	IP68

¹⁾ IP64 with dry run at shaft exit.

Synchronous motors Dimension drawings

1FT6 motors without/with DRIVE-CLiQ Natural cooling

For motor		Dimensions in mm (in)													Encoder system: Resolver			
Shaft height	Type	DIN IEC	a ₁ P	b ₁ N	c ₁ LA	e ₁ M	f AB	f ₁ T	With- out DRIVE- CLiQ	With DRIVE- CLiQ	h H	i ₂ -	s ₂ S	o ₁	Without brake		With brake	
									g ₂ -	g ₂ -					k LB	o -	k LB	o -
1FT6, type IM B5, natural cooling, with connector, without/with brake																		
28	1FT6021		-	40 (1.57)	9.8 (0.39)	63 (2.48)	55 (2.17)	2.5 (0.10)	64 (2.52)	73.5 (2.89)	28 (1.10)	20 (0.79)	5.8 (0.23)	34.5 (1.36)	193 (7.60)	122 (4.80)	218 (8.58)	147 (5.79)
	1FT6024														233 (9.17)	162 (6.38)	258 (10.16)	187 (7.36)
36	1FT6031		92 (3.62)	60 (2.36)	8 (0.31)	75 (2.95)	72 (2.83)	3 (0.12)	76 (2.99)	86 (3.39)	36 (1.42)	30 (1.18)	5.5 (0.22)	-	180 (7.09)	151 (5.94)	200 (7.87)	171 (6.73)
	1FT6034														220 (8.66)	191 (7.52)	240 (9.45)	211 (8.31)

Shaft height	Type	DIN IEC	Encoder system: Incremental encoder Absolute encoder				DE shaft extension				
			Without brake		With brake		d D	d ₆ -	l E	t GA	u F
28	1FT6021		193 (7.60)	122 (4.80)	218 (8.58)	147 (5.79)	9 (0.35)	M8	20 (0.79)	10.2 (0.40)	3 (0.12)
	1FT6024		233 (9.17)	162 (6.38)	258 (10.16)	187 (7.36)					
36	1FT6031		220 (8.66)	151 (5.94)	240 (9.45)	171 (6.73)	14 (0.55)	M5	30 (1.18)	16 (0.63)	5 (0.20)
	1FT6034		260 (10.24)	191 (7.52)	280 (11.02)	211 (8.31)					

1FT602

Shaft version with fitted key

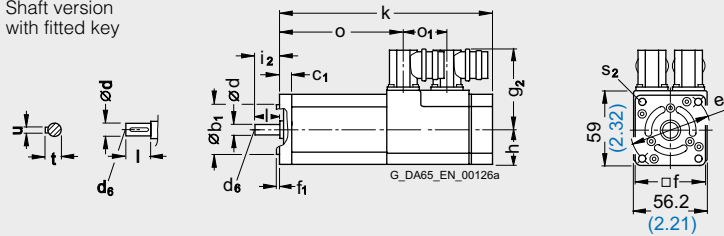

1FT603

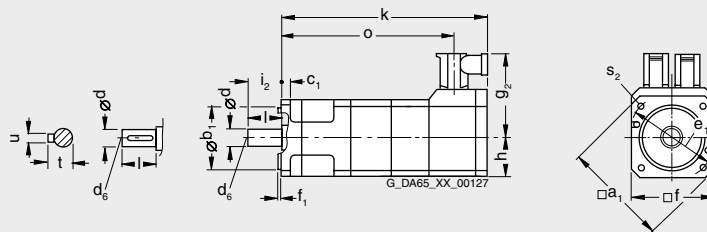

Synchronous motors

Dimension drawings

1FT6 motors without/with DRIVE-CLiQ Natural cooling

For motor		Dimensions in mm (in)													Encoder system: Resolver			
Shaft height	Type	DIN IEC	a ₁ P	b ₁ N	c ₁ LA	e ₁ M	f AB	f ₁ T	With- out DRIVE- CLiQ	With DRIVE- CLiQ	h H	i ₂ -	s ₂ ¹⁾ S	s ₂ ²⁾ S	Without brake		With brake	
									g ₂ -	g ₂ -					k LB	o -	k LB	o -
1FT6, type IM B5, natural cooling, with connector, without/with brake																		
48	1FT6041		120 (4.72)	80 (3.15)	10 (0.39)	100 (3.94)	96 (3.78)	3 (0.12)	80 (3.15)	90 (3.54)	48 (1.89)	40 (1.57)	7 (0.28)	M6	185 (7.28)	159 (6.26)	220 (8.66)	194 (7.64)
	1FT6044														235 (9.25)	209 (8.23)	270 (10.63)	244 (9.61)
63	1FT6061		146 (5.75)	110 (4.33)	10 (0.39)	130 (5.12)	116 (4.57)	3.5 (0.14)	90 (3.54)	100 (3.94)	58 (2.28)	50 (1.97)	9 (0.35)	M8	198 (7.80)	172 (6.77)	228 (8.98)	202 (7.95)
	1FT6062														223 (8.78)	197 (7.76)	253 (9.96)	227 (8.94)
	1FT6064														273 (10.75)	247 (9.72)	303 (11.93)	277 (10.91)

Shaft height	Type	DIN IEC	Encoder system: Incremental encoder Absolute encoder				DE shaft extension				
			Without brake		With brake		d D	d ₆ -	l E	t GA	u F
48	1FT6041		k LB	o -	k LB	o -	19 (0.75)	M6	40 (1.57)	21.5 (0.85)	6 (0.24)
	1FT6044		228 (8.98)	157 (6.18)	263 (10.35)	192 (7.56)	278 (10.94)	207 (8.15)	313 (12.32)	242 (9.53)	
63	1FT6061		228 (8.98)	172 (6.77)	258 (10.16)	202 (7.95)	24 (0.94)	M8	50 (1.97)	27 (1.06)	8 (0.31)
	1FT6062		253 (9.96)	197 (7.76)	283 (11.14)	227 (8.94)					
	1FT6064		303 (11.93)	247 (9.72)	333 (13.11)	277 (10.91)					

**1FT604
1FT606**

Shaft version
with fitted key

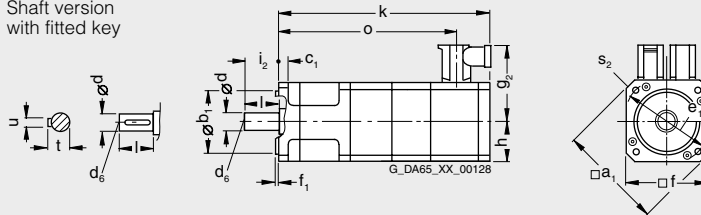

1) IM B5
2) IM B14

Synchronous motors Dimension drawings

1FT6 motors without/with DRIVE-CLiQ Natural cooling

For motor		Dimensions in mm (in)														Encoder system: Resolver			
Shaft height	Type	DIN IEC	a ₁ P	b ₁ N	c ₁ LA	e ₁ M	f AB	f ₁ T	g ₂ -	h H	i ₂ -	s ₂ ¹⁾ S	s ₂ ²⁾ S	o ₁ -	Without brake		With brake		
															k LB	o -	k LB	o -	
1FT6, type IM B5, natural cooling, with connector, without/with brake																			
80	1FT6081		194 (7.64)	130 (5.12)	12 (0.47)	165 (6.50)	155 (6.10)	3.5 (0.14)	127.5 (5.02)	77.5 (3.05)	58 (2.28)	11 (0.43)	M10	76 (2.99)	221 (8.70)	113 (4.45)	248 (9.76)	140 (5.51)	
	1FT6082														246 (9.69)	138 (5.43)	273 (10.75)	165 (6.50)	
	1FT6084														296 (11.65)	188 (7.40)	342 (13.46)	234 (9.21)	
	1FT6086														346 (13.62)	238 (9.37)	392 (15.43)	284 (11.18)	

Shaft height	Type	DIN IEC	Encoder system: Incremental encoder Absolute encoder				DE shaft extension				
			Without brake		With brake		d D	d ₆ -	l E	t GA	u F
80	1FT6081		221 (8.70)	113 (4.45)	248 (9.76)	140 (5.51)	32 (1.26)	M12	58 (2.28)	35 (1.38)	10 (0.39)
	1FT6082		246 (9.69)	138 (5.43)	273 (10.75)	165 (6.50)					
	1FT6084		296 (11.65)	188 (7.40)	342 (13.46)	234 (9.21)					
	1FT6086		346 (13.62)	238 (9.37)	392 (15.43)	284 (11.18)					

1FT608

Shaft version with fitted key

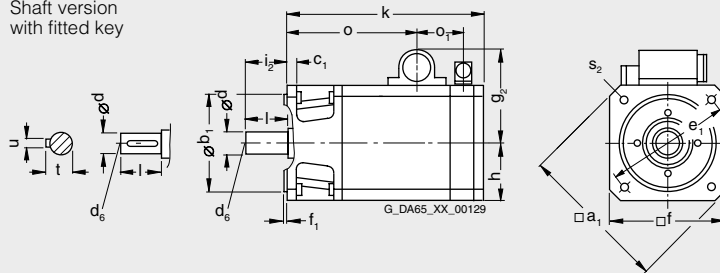

1) IM B5
2) IM B14

Synchronous motors

Dimension drawings

1FT6 motors without/with DRIVE-CLiQ Natural cooling

For motor		Dimensions in mm (in)														
Shaft height	Type	DIN IEC	a ₁ P	b ₁ N	c ₁ LA	e ₁ M	f AB	f ₁ T	Connector Size		h H	i ₂ -	p HD	s ₂ ¹⁾ S	s ₂ ²⁾ S	o ₁ -
									1.5	3						
									g ₂ -	g ₂ -						

1FT6, type IM B5, natural cooling, with connector, without/with brake																
100	1FT6102 1FT6105 1FT6108		240 (9.45)	180 (7.09)	13 (0.51)	215 (8.46)	192 (7.56)	4 (0.16)	146 (5.75)	172 (6.77)	96 (3.78)	80 (3.15)	155 (6.10)	14 (0.55)	M12	76 (2.99)
132	1FT6132 1FT6134 1FT6136	-	-	250 (9.84)	18 (0.71)	300 (11.81)	260 (10.24)	5 (0.20)	172.5 (6.79)	198.5 (7.81)	132 (5.20)	82 (3.23)	245 (9.65)	18 (0.71)	-	66 (2.60)

Shaft height	Type	DIN IEC	Encoder system:				Incremental encoder				DE shaft extension				
			Resolver		With brake		Without brake		With brake		d D	d ₆ -	l E	t GA	u F
			Without brake	With brake	Without brake	With brake	k LB	o -	k LB	o -					
100	1FT6102 1FT6105 1FT6108		295 (11.61)	186 (7.32)	341 (13.43)	232 (9.13)	295 (11.61)	186 (7.32)	341 (13.43)	232 (9.13)	38 (1.50)	M12	80 (3.15)	41 (1.61)	10 (0.39)
132	1FT6132 1FT6134 1FT6136		423 (16.65)	288 (11.34)	473 (18.62)	338 (13.31)	423 (16.65)	288 (11.34)	473 (18.62)	338 (13.31)	48 (1.89)	M16	82 (3.23)	52.5 (2.07)	14 (0.55)

1FT610 Shaft version with fitted key

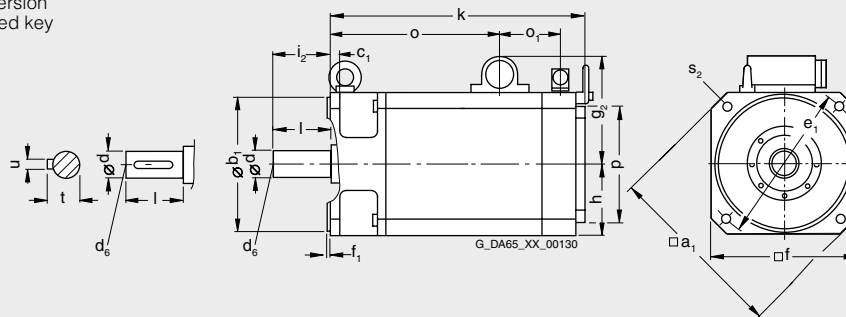

1FT613

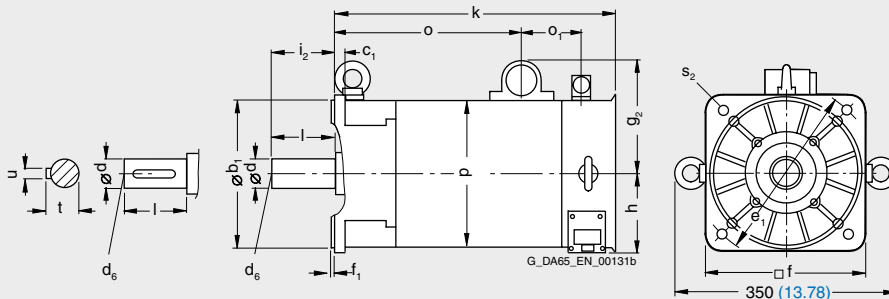

1) IM B5
2) IM B14

Synchronous motors Dimension drawings

1FT6 motors without/with DRIVE-CLiQ Natural cooling

For motor		Dimensions in mm (in)															
Shaft height	Type	DIN IEC	a ₁ P	b ₁ N	c ₁ LA	e ₁ M	f AB	f ₁ T	Terminal box		h H	i ₂ -	p HD	s ₂ ¹⁾ S	s ₂ ²⁾ S	s ₃ -	o ₁ -
									gk 130	gk 230							
1FT6, type IM B5, natural cooling, with terminal box, without/with brake																	
100	1FT6102 1FT6105 1FT6108		240 (9.45)	180 (7.09)	13 (0.51)	215 (8.46)	192 (7.56)	4 (0.16)	155 (6.10)	160 (6.30)	96 (3.78)	80 (3.15)	155 (6.10)	14 (0.55)	M12	PG29	76 (2.99)
132	1FT6132 1FT6134 1FT6136		-	250 (9.84)	18 (0.71)	300 (11.81)	260 (10.24)	5 (0.20)	-	194 (7.64)	132 (5.20)	82 (3.23)	245 (9.65)	18 (0.71)	-	PG29/ PG36	-

Shaft height	Type	DIN IEC	Encoder system: Resolver								Incremental encoder Absolute encoder				DE shaft extension				
			Without brake				With brake				Without brake		With brake		d D	d ₆ -	l E	t GA	u F
			k LB	o -	k LB	o -	k LB	o -	k LB	o -									
100	1FT6102 1FT6105 1FT6108		295 (11.61)	186 (7.32)	341 (13.43)	232 (9.13)	295 (11.61)	186 (7.32)	341 (13.43)	232 (9.13)	38 (1.50)	M12	80 (3.15)	41 (1.61)	10 (0.39)				
132	1FT6132 1FT6134 1FT6136		423 (16.65)	288 (11.34)	473 (18.62)	338 (13.31)	423 (16.65)	288 (11.34)	473 (18.62)	338 (13.31)	48 (1.89)	M16	82 (3.23)	51.5 (2.03)	14 (0.55)				

1FT610

Shaft version with fitted key

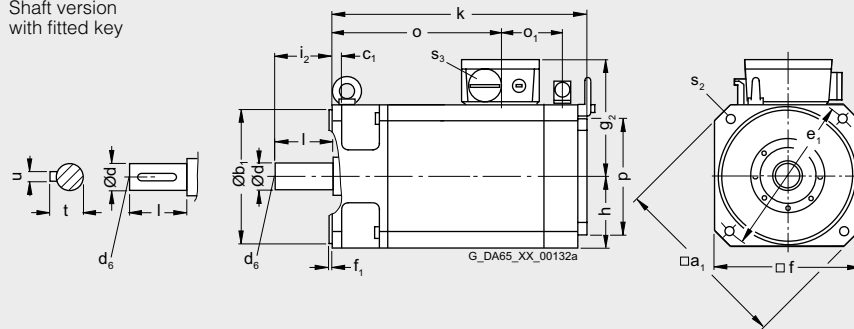

1FT613

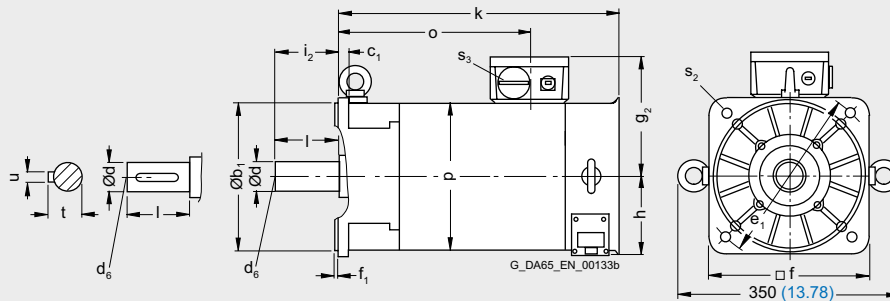

1) IM B5
2) IM B14

Synchronous motors

Dimension drawings

**1FT6 motors without/with DRIVE-CLiQ
Forced ventilation**

For motor		Dimensions in mm (in)															
Shaft height	Type	DIN IEC	a ₁ P	b ₁ N	c ₁ LA	e ₁ M	f AB	f ₁ T	Connector		h H	i ₂ -	p HD	s ₂ ¹⁾ S	s ₂ ²⁾ S	o ₁ -	o ₂ -
									Size 1.5	3							
1FT6, type IM B5, forced ventilation, with connector, without/with brake																	
80	1FT6084 1FT6086		194 (7.64)	130 (5.12)	12 (0.47)	165 (6.50)	185 (7.28)	3.5 (0.14)	140 (5.51)	154 (6.06)	93 (3.66)	58 (2.28)	175 (6.89)	11 (0.43)	M10	76 (2.99)	169 (6.65)
100	1FT6105 1FT6108		240 (9.45)	180 (7.09)	13 (0.51)	215 (8.46)	221 (8.70)	4 (0.16)	158 (6.22)	172 (6.77)	111 (4.37)	80 (3.15)	212 (8.35)	14 (0.55)	M12	76 (2.99)	170 (6.69)

Shaft height	Type	DIN IEC	Encoder system:				DE shaft extension							
			Resolver		Incremental encoder		Without brake		With brake					
			Without brake		With brake		d	d ₆	l	t	u			
			k	o	k	o	D	-	E	GA	F			
80	1FT6084 1FT6086		399 (15.71)	188 (7.40)	445 (17.52)	234 (9.21)	32 (1.26)	M12	58 (2.28)	35 (1.38)	10 (0.39)			
100	1FT6105 1FT6108		473 (18.62)	261 (10.28)	519 (20.43)	307 (12.09)	38 (1.50)	M12	80 (3.15)	41 (1.61)	10 (0.39)			
			573 (22.56)	361 (14.21)	619 (24.37)	407 (16.02)								

1FT608

Shaft version with fitted key

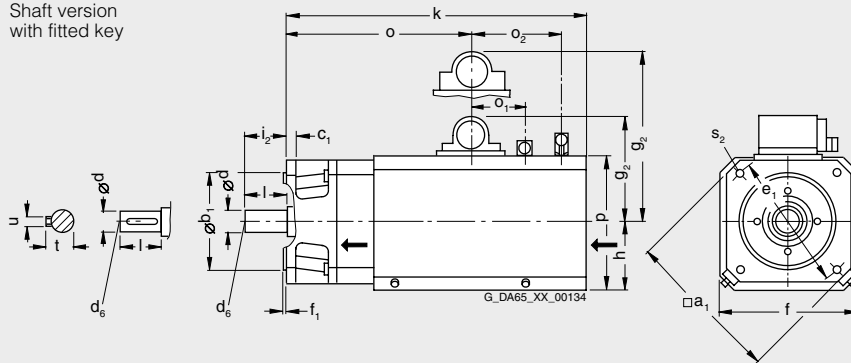

1FT610

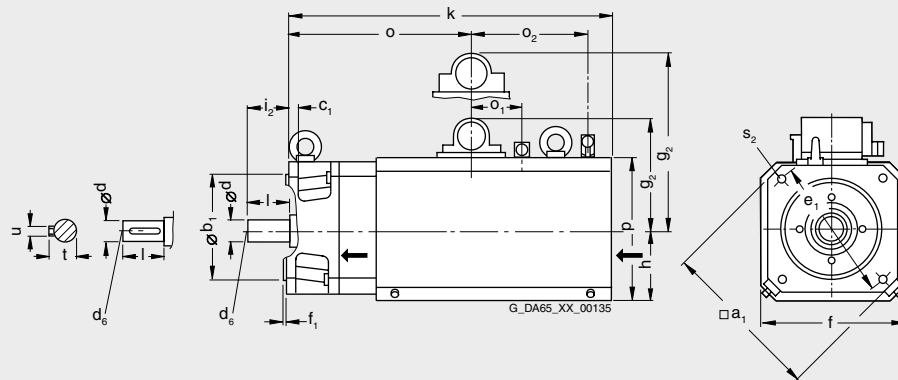

1) IM B5
2) IM B14



Synchronous motors

Dimension drawings

1FT6 motors without/with DRIVE-CLiQ Forced ventilation

For motor Dimensions in mm (in)

Shaft height	Type	DIN IEC	a ₁ P	b ₁ N	c ₁ LA	e ₁ M	f AB	f ₁ T	g ₂ -	h H	i ₂ -	p HD	s ₂ ¹⁾ S	s ₂ ²⁾ S	o ₁ -	o ₂ -
1FT6, type IM B5, forced ventilation, with connector, without/with brake																
132	1FT6132 1FT6134 1FT6136		-	250 (9.84)	18 (0.71)	300 (11.81)	260 (10.24)	5 (0.20)	198.5 (7.81)	132 (5.20)	82 (3.23)	245 (9.65)	18 (0.71)	-	66 (2.60)	-

Shaft height	Type	DIN IEC	Encoder system:				DE shaft extension				
			Without brake		With brake		d	d ₆	l	t	u
			k LB	o -	k LB	o -	D	-	E	GA	F
132	1FT6132 1FT6134 1FT6136		541 (21.30)	288 (11.34)	591 (23.27)	338 (13.31)	48 (1.89)	M16	82 (3.23)	51.5 (2.03)	14 (0.55)
			591 (23.27)	338 (13.31)	641 (25.24)	388 (15.28)					
			641 (25.24)	388 (15.28)	691 (27.20)	438 (17.24)					

1FT613

Shaft version with fitted key

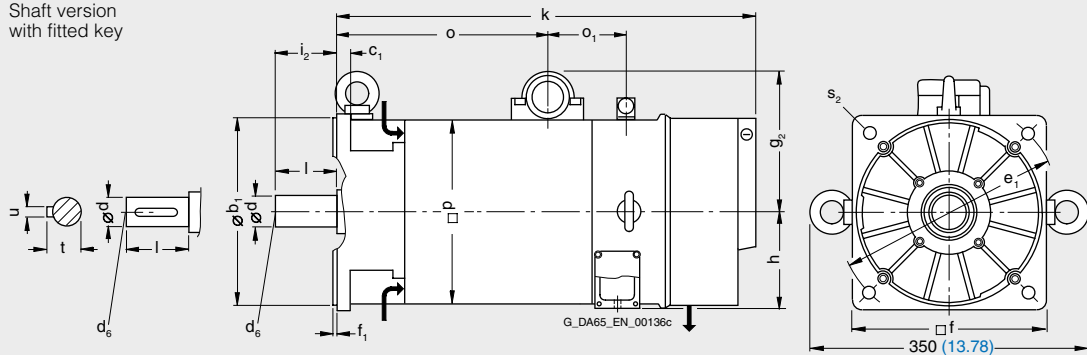

1) IM B5
2) IM B14

Synchronous motors

Dimension drawings

**1FT6 motors without/with DRIVE-CLiQ
Forced ventilation**

For motor		Dimensions in mm (in)															
Shaft height	Type	DIN IEC	a ₁ P	b ₁ N	c ₁ LA	e ₁ M	f AB	f ₁ T	Terminal box			i ₂	p HD	s ₂ ¹⁾ S	s ₂ ²⁾ S	s ₃	
									gk 130	gk 230	gk 420						
1FT6, type IM B5, forced ventilation, with terminal box, without/with brake																	
100	1FT6105 1FT6108		240 (9.45)	180 (7.09)	13 (0.51)	215 (8.46)	221 (8.70)	4 (0.16)	167 (6.57)	172 (6.77)	–	111 (4.37)	80 (3.15)	212 (8.35)	14 (0.55)	M12	PG29
132	1FT6132 1FT6134 1FT6136		–	250 (9.84)	18 (0.71)	300 (11.81)	260 (10.24)	5 (0.20)	–	186.5 (7.34)	202 (7.95)	132 (5.20)	82 (3.23)	245 (9.65)	18 (0.71)	–	PG29/ PG36

Shaft height	Type	DIN IEC	o ₁	o ₂	Encoder system:				DE shaft extension								
					Resolver	Incremental encoder	Absolute encoder	Without brake	With brake	d	d ₆	l	t	u			
			–	–	k LB	o –	k LB	o –	D	–	E	GA	F				
100	1FT6105 1FT6108		76 (2.99)	170 (6.69)	473 (18.62)	261 (10.28)	519 (20.43)	307 (12.09)	38 (1.50)	M12	80 (3.15)	41 (1.61)	10 (0.39)				
132	1FT6132 1FT6134 1FT6136		–	–	541 (21.30)	288 (11.34)	591 (23.27)	338 (13.31)	48 (1.89)	M16	82 (3.23)	51.5 (2.03)	14 (0.55)				

1FT610

Shaft version with fitted key

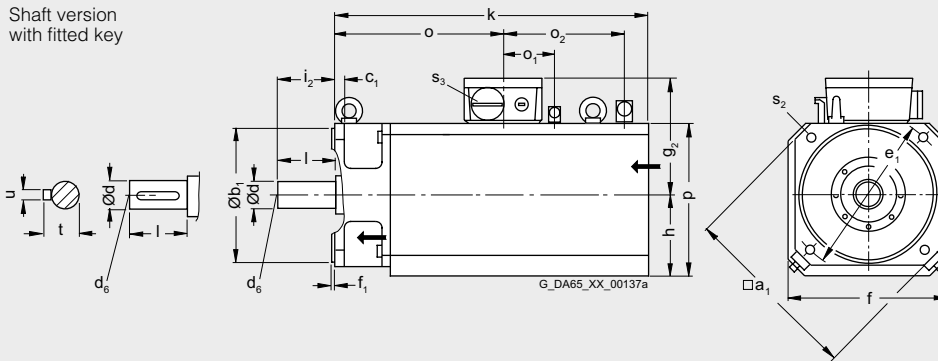

1FT613

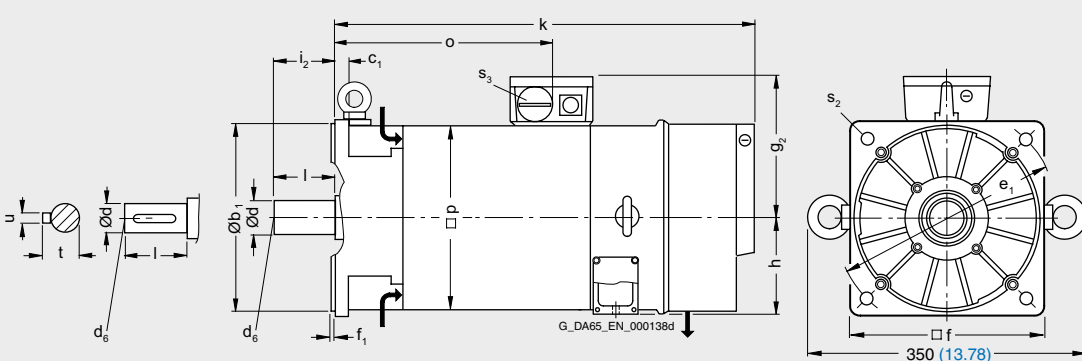

1) IM B5
2) IM B14



Synchronous motors Dimension drawings

1FT6 motors without/with DRIVE-CLiQ Water cooling

For motor		Dimensions in mm (in)															
Shaft height	Type	DIN IEC	a ₁ P	b ₁ N	c ₁ LA	e ₁ M	f AB	f ₁ T	Connector Size				h H	i ₂ -	p HD	s ₂ ¹⁾ S	s ₂ ²⁾ S
									With DRIVE-CLiQ	Without DRIVE-CLiQ	1	1.5					
1FT6, type IM B5, water cooling, with connector, without/with brake																	
63	1FT6062 1FT6064		146 (5.75)	110 (4.33)	10 (0.39)	130 (5.12)	116 (4.57)	3.5 (0.14)	g ₂ -	g ₂ -	g ₂ -	g ₂ -	58 (2.28)	50 (1.97)	-	9 (0.35)	M8
80	1FT6084 1FT6086		194 (7.64)	130 (5.12)	12 (0.47)	165 (6.50)	155 (6.10)	3.5 (0.14)	-	-	139.5 (5.49)	153.5 (6.04)	77.5 (3.05)	58 (2.28)	-	11 (0.43)	M10

Shaft height	Type	DIN IEC	Encoder system:				Resolver		Incremental encoder		Absolute encoder		DE shaft extension						
			Resolver		Incremental encoder		Absolute encoder		Without/with brake		Without/with brake		d D	d ₆ -	l E	t GA	u F		
			Without brake	With brake	Without/with brake	With brake	Without/with brake	With brake											
63	1FT6062 1FT6064		-	-	-	-	253 (9.96)	227 (8.94)	283 (11.14)	227 (8.94)	303 (11.93)	277 (10.91)	283 (11.11)	277 (10.91)	24 (0.94)	M8	50 (1.97)	27 (1.06)	8 (0.31)
80	1FT6084 1FT6086		76 (2.99)	296 (11.65)	188 (7.40)	342 (13.46)	234 (9.21)	-	-	-	-	-	-	-	32 (1.26)	M12	58 (2.28)	35 (1.38)	10 (0.39)

1FT606

Shaft version with fitted key

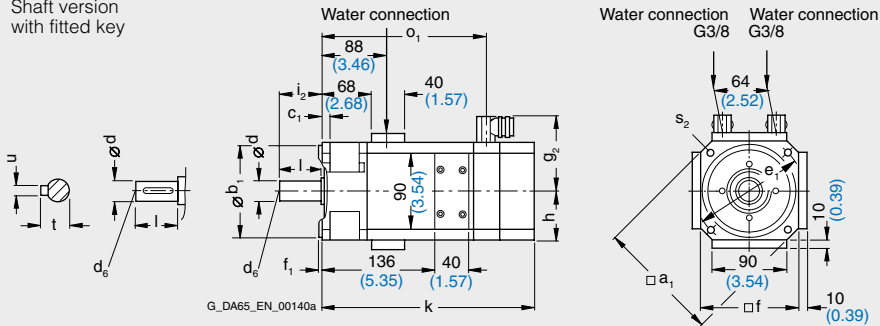

1FT608

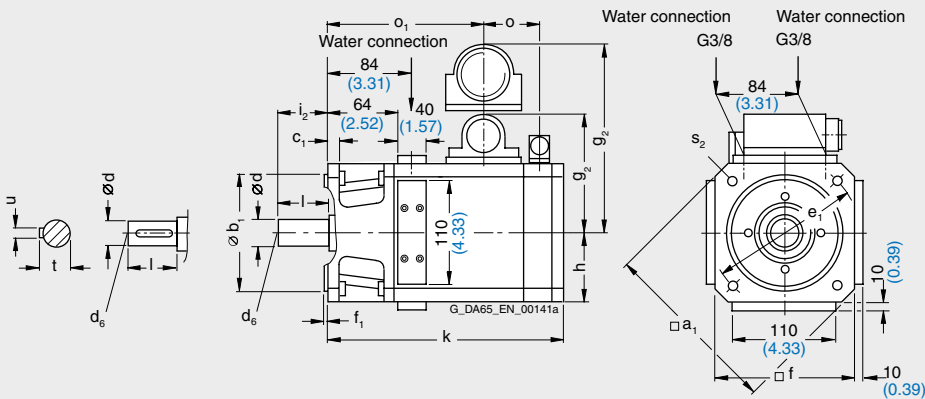

1) IM B5
2) IM B14



Synchronous motors

Dimension drawings

1FT6 motors without/with DRIVE-CLiQ Water cooling

For motor		Dimensions in mm (in)														
Shaft height	Type	DIN IEC	a ₁ P	b ₁ N	c ₁ LA	e ₁ M	f AB	f ₁ T	Connector		h H	i ₂ -	p HD	s ₂ ¹⁾ S	s ₂ ²⁾ S	o -
									1.5	3						

1FT6, type IM B5, water cooling, with connector, without/with brake																
100	1FT6105 1FT6108		240 (9.45)	180 (7.09)	13 (0.51)	215 (8.46)	192 (7.56)	4 (0.16)	158 (6.22)	172 (6.77)	96 (3.78)	80 (3.15)	155 (6.10)	14 (0.55)	M12	76 (2.99)

Shaft height	Type	DIN IEC	Encoder system:				DE shaft extension				
			Without brake		With brake		d	d ₆	l	t	u
			k	o ₁	k	o ₁	D	-	E	GA	F
100	1FT6105 1FT6108		370 (14.57)	261 (10.28)	416 (16.38)	307 (12.09)	38 (1.50)	M12	80 (3.15)	41 (1.61)	10 (0.39)
			470 (18.50)	361 (14.21)	516 (20.31)	407 (16.02)					

1FT610

Shaft version with fitted key

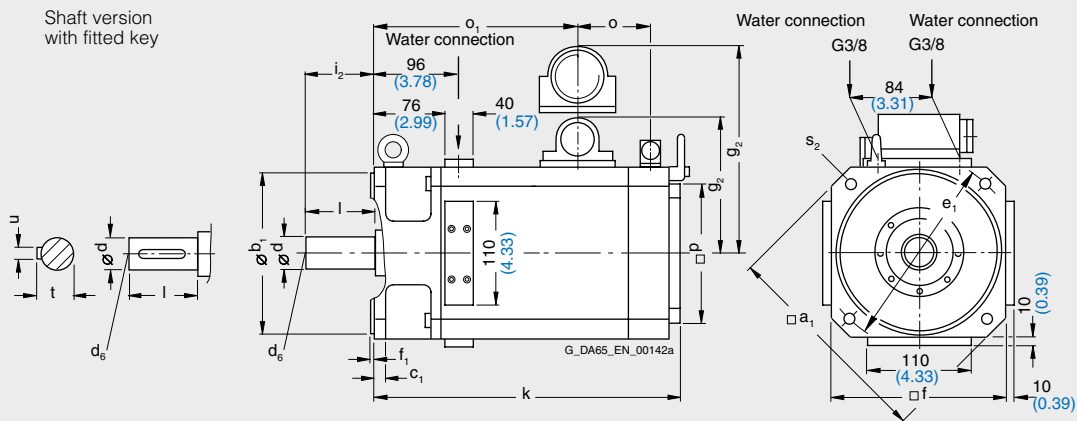

1) IM B5
2) IM B14

Synchronous motors

Dimension drawings

1FT6 motors without/with DRIVE-CLiQ Water cooling

For motor		Dimensions in mm (in)																	
Shaft height	Type	DIN IEC	a B	b A	b ₁ N	c LA	c ₁ -	e BB	e ₁ M	f AB	f ₁ T	f ₂ -	h H	i ₂ -	k LB	m BA	m ₁ -	m ₂ -	
1FT6, type IM B35, water cooling, with terminal box																			
132	1FT6132		342 (13.46)	216 (8.50)	250 (9.84)	14 (0.55)	16 (0.63)	366 (14.41)	300 (11.81)	260 (10.24)	5 (0.20)	245 (9.65)	132 (5.20)	82 (3.23)	423 (16.65)	36 (1.42)	53 (2.09)	23 (0.91)	
	1FT6134		392 (15.43)					416 (16.38)							473 (18.62)				
	1FT6136		442 (17.40)					466 (18.35)							523 (20.59)				
	1FT6138		517 (20.35)					541 (21.30)							598 (23.54)				

Shaft height	Type	DIN IEC	n AA	o -	p HD	p ₁ AC	s K	s ₂ K	s ₃ -	n _{rated} = 1500 rpm	n _{rated} = 2500 rpm	DE shaft extension				
										s ₃ -	w ₁ C	d D	d ₆ -	l E	t GA	u F
132	1FT6132		14 (0.55)	255.5 (10.06)	350.5 (13.80)	245 (9.65)	12 (0.47)	18 (0.71)	M32 x 1.5	M40 x 1.5	53 (2.09)	48 (1.89)	M16	82 (3.23)	51.5 (2.03)	14 (0.55)
	1FT6134			305.5 (12.03)					M40 x 1.5	M50 x 1.5						
	1FT6136			355.5 (14.00)					M50 x 1.5	M50 x 1.5						
	1FT6138			430.5 (16.95)					M50 x 1.5	M50 x 1.5						

1FT613

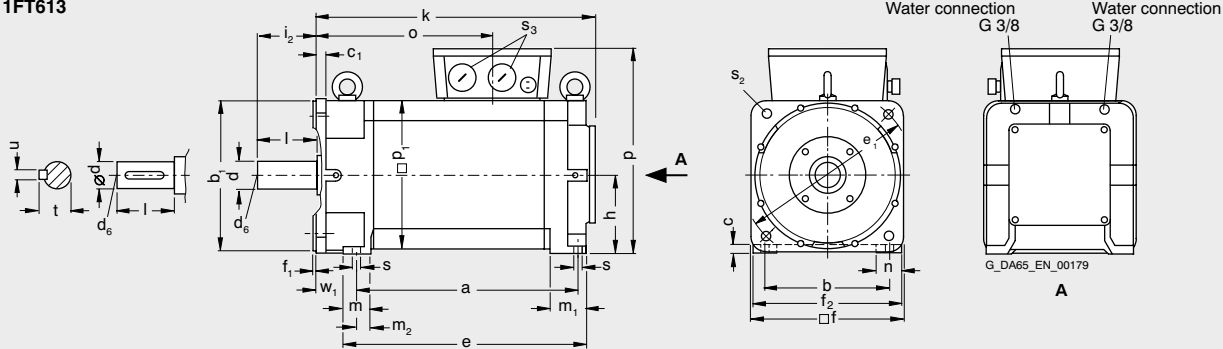

Synchronous motors

Dimension drawings

1FT7 Compact motors without/with DRIVE-CLiQ Natural cooling

For motor		Dimensions in mm (in)											Flange 1 (1FT6-compatible)			
Shaft height	Type	DIN IEC	a ₁ P	b ₁ N	c ₁ LA	e ₁ M	f AB	f ₁ T	g ₂ -	o ₁ -	s ₂ S	i ₂ -	Without brake		With brake	
													k LB	o -	k LB	o -
1FT7 Compact, type IM B5, natural cooling, with connector, without/with brake																
36	1FT7034		90 (3.54)	60 (2.36)	8 (0.31)	75 (2.95)	72 (2.83)	3 (0.12)	80 (3.15)	52 (2.05)	5.5 (0.22)	30 (1.18)	195 (7.68)	134 (5.28)	222 (8.74)	161 (6.34)
	1FT7036												243 (9.57)	182 (7.17)	270 (10.63)	209 (8.23)
48	1FT7042		120 (4.72)	80 (3.15)	10 (0.39)	100 (3.94)	96 (3.78)	3 (0.12)	93 (3.66)	52 (2.05)	6.5 (0.26)	40 (1.57)	169 (6.65)	102 (4.02)	201 (7.91)	134 (5.28)
	1FT7044												219 (8.62)	152 (5.98)	251 (9.88)	184 (7.24)
	1FT7046												259 (10.20)	192 (7.56)	291 (11.46)	224 (8.82)
63	1FT7062		155 (6.10)	110 (4.33)	10 (0.39)	130 (5.12)	126 (4.96)	3.5 (0.14)	105 (4.13)	52 (2.05)	9 (0.35)	50 (1.97)	173 (6.81)	106 (4.17)	208 (8.19)	141 (5.55)
	1FT7064												205 (8.07)	137 (5.39)	240 (9.45)	172 (6.77)
	1FT7066												236 (9.29)	169 (6.65)	272 (10.71)	204 (8.03)
	1FT7068												284 (11.18)	216 (8.50)	319 (12.56)	251 (9.88)

Shaft height	Type	DIN IEC	Flange 0			Without brake		With brake		DE shaft extension				
			b ₂ -	i ₂ -	f ₂ -	k LB	o -	k LB	o -	d D	d ₆ -	l E	t GA	u F
36	1FT7034		36 (1.42)	36.5 (1.44)	5.5 (0.22)	189 (7.44)	127 (5.00)	216 (8.50)	154 (6.06)	14 (0.55)	M5	30 (1.18)	16 (0.63)	5 (0.20)
	1FT7036					237 (9.33)	175 (6.89)	264 (10.39)	202 (7.95)					
48	1FT7042		46 (1.81)	46 (1.81)	5.5 (0.22)	163 (6.42)	96 (3.78)	195 (7.68)	128 (5.04)	19 (0.75)	M6	40 (1.57)	21.5 (0.85)	6 (0.24)
	1FT7044					213 (8.39)	146 (5.75)	245 (9.65)	178 (7.01)					
	1FT7046					253 (9.96)	186 (7.32)	285 (11.22)	218 (8.58)					
63	1FT7062		51 (2.01)	56.5 (2.22)	6 (0.24)	166 (6.54)	100 (3.94)	202 (7.95)	135 (5.31)	24 (0.94)	M8	50 (1.97)	27 (1.06)	8 (0.31)
	1FT7064					198 (7.80)	131 (5.16)	233 (9.17)	166 (6.54)					
	1FT7066					230 (9.06)	163 (6.42)	265 (10.43)	198 (7.80)					
	1FT7068					277 (10.91)	210 (8.27)	312 (12.28)	245 (9.65)					

Flange 0
1FT703
1FT704
1FT706

Shaft version
with fitted key

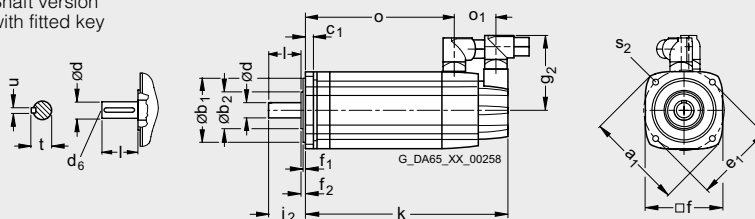

Flange 1
(1FT6-compatible)
1FT703
1FT704
1FT706

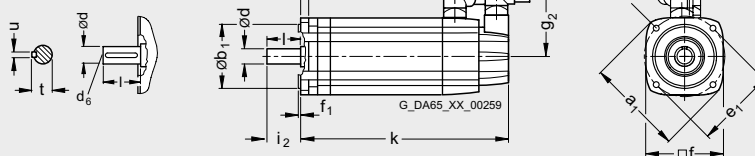

Synchronous motors

Dimension drawings

1FT7 Compact motors without/with DRIVE-CLiQ Natural cooling

For motor		Dimensions in mm (in)											Flange 1 (1FT6-compatible)			
Shaft height	Type	DIN IEC	a ₁ P	b ₁ N	c ₁ LA	e ₁ M	f AB	f ₁ T	g ₂ –	o ₁ –	s ₂ S	i ₂ –	Without brake		With brake	
													k LB	o –	k LB	o –
1FT7 Compact, type IM B5, natural cooling, with connector, without/with brake																
80	1FT7082		195 (7.68)	130 (5.12)	11.5 (0.45)	165 (6.50)	155 (6.10)	3.5 (0.14)	141 (5.55)	50 (1.97)	11 (0.43)	58 (2.28)	196 (7.72)	130 (5.12)	248 (9.76)	183 (7.20)
	1FT7084												247 (9.72)	165 (6.50)	299 (11.77)	234 (9.21)
	1FT7086												299 (11.77)	234 (9.21)	351 (13.82)	286 (11.26)
100	1FT7102		245 (9.65)	180 (7.09)	13 (0.51)	215 (8.46)	196 (7.72)	4 (0.16)	161 (6.34)	55 (2.17)	14 (0.55)	80 (3.15)	221 (8.70)	151 (5.94)	273 (10.75)	203 (7.99)
	1FT7105												307 (12.09)	238 (9.37)	360 (14.17)	290 (11.42)
	1FT7108												377 (14.84)	307 (12.09)	429 (16.89)	359 (14.13)

Shaft height	Type	DIN IEC	Flange 0			Without brake		With brake		DE shaft extension				
			b ₂ –	i ₂ –	f ₂ –	k LB	o –	k LB	o –	d D	d ₆ –	l E	t GA	u F
80	1FT7082		66 (2.60)	64.5 (2.54)	6 (0.24)	189 (7.44)	124 (4.88)	241 (9.49)	177 (6.97)	32 (1.26)	M12	58 (2.28)	35 (1.38)	10 (0.39)
	1FT7084					241 (9.49)	159 (6.26)	293 (11.54)	228 (8.98)					
	1FT7086					292 (11.50)	228 (8.98)	345 (13.58)	280 (11.02)					
100	1FT7102		81 (3.19)	87 (3.43)	6.5 (0.26)	214 (8.43)	144 (5.67)	266 (10.47)	196 (7.72)	38 (1.50)	M12	80 (3.15)	41 (1.61)	10 (0.39)
	1FT7105					301 (11.85)	231 (9.09)	353 (13.90)	283 (11.14)					
	1FT7108					370 (14.57)	300 (11.81)	422 (16.61)	352 (13.86)					

Flange 0
1FT708
1FT710

Shaft version
with fitted key

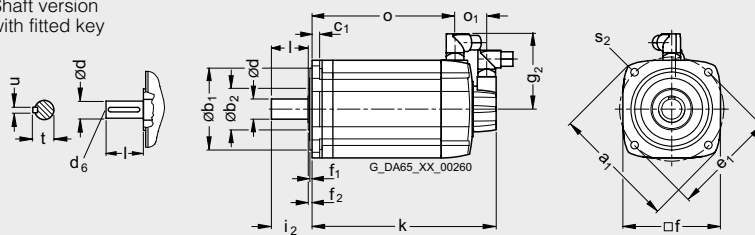

Flange 1
(1FT6-compatible)
1FT708
1FT710

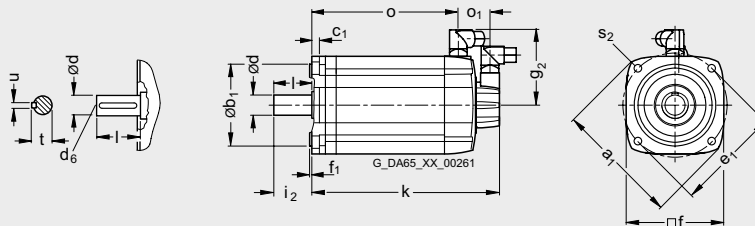

Synchronous motors

Dimension drawings

1FK7 Compact motors without/with DRIVE-CLiQ Natural cooling

For motor		Dimensions in mm (in)												Encoder system:							
Shaft height	Type	DIN IEC	a ₁ P	b ₁ N	c ₁ LA	e ₁ M	f AB	f ₁ T	g ₂ -	h H	i ₂ -	s ₂ S	Resolver			Absolute encoder EnDat 16 S/R			Absolute encoder 15 bit (16 S/R)		
													Without brake			With brake			Without brake		
													k LB	o ₁ -	o ₂ -	k LB	o ₁ -	o ₂ -			
1FK7 Compact, type IM B5, natural cooling, with connector, without/with brake																					
20	1FK7011-5	-		30 (1.18)	7 (0.28)	46 (1.81)	40 (1.57)	2.5 (0.10)	65.5 (2.58)	20 (0.79)	18 (0.71)	4.5 (0.18)	140 (5.51)	89 (3.50)	118 (4.65)	140 (5.51)	89 (3.50)	118 (4.65)			
	1FK7015-5												165 (6.50)	114 (4.49)	143 (5.63)	165 (6.50)	114 (4.49)	143 (5.63)			
28	1FK7022-5	-		40 (1.57)	10 (0.39)	63 (2.48)	55 (2.17)	2.5 (0.10)	75 (2.95)	27.5 (1.08)	20 (0.79)	5.4 (0.21)	153 (6.02)	95 (3.74)	128 (5.04)	175 (6.89)	95 (3.74)	150 (5.91)			
	1FK7032-5												150 (5.91)	90 (3.54)	125 (4.92)	175 (6.89)	90 (3.54)	149 (5.87)			
36	1FK7032-5		92 (3.62)	60 (2.36)	8 (0.31)	75 (2.95)	72 (2.83)	3 (0.12)	81 (3.19)	36 (1.42)	30 (1.18)	6.5 (0.26)	150 (5.91)	90 (3.54)	125 (4.92)	175 (6.89)	90 (3.54)	149 (5.87)			
	1FK7034-5												175 (6.89)	115 (4.53)	150 (5.91)	200 (7.87)	115 (4.53)	174 (6.85)			
48	1FK7040-5		120 (4.72)	80 (3.15)	10 (0.39)	100 (3.94)	96 (3.78)	3 (0.12)	90 (3.54)	48 (1.89)	40 (1.57)	7 (0.28)	134 (5.28)	73 (2.87)	106 (4.17)	163 (6.42)	73 (2.87)	135 (5.31)			
	1FK7042-5												162 (6.38)	101 (3.98)	134 (5.28)	191 (7.52)	101 (3.98)	163 (6.42)			
63	1FK7060-5		155 (6.10)	110 (4.33)	10 (0.39)	130 (5.12)	126 (4.96)	3.5 (0.14)	105 (4.13)	63 (2.48)	50 (1.97)	9 (0.35)	157 (6.18)	94 (3.70)	126 (4.96)	200 (7.87)	94 (3.70)	169 (6.65)			
	1FK7063-5												202 (7.95)	139 (5.47)	171 (6.73)	245 (9.65)	139 (5.47)	214 (8.43)			

Shaft height	Type	Encoder system:												DE shaft extension															
		Incremental encoder sin/cos1 V _{pp}			Incremental encoder 22 bit (2048 S/R)			Absolute encoder EnDat 32 S/R			Absolute encoder 16 bit (32 S/R)			Absolute encoder EnDat 2048 S/R			Absolute encoder 22 bit (2048 S/R)			Absolute encoder EnDat 512 S/R			Absolute encoder 20 bit (512 S/R)						
													Without brake			With brake			Without brake			With brake			d D	d ₆ -	l E	t GA	u F
													k LB	o ₁ -	o ₂ -	k LB	o ₁ -	o ₂ -	k LB	o ₁ -	o ₂ -	k LB	o ₁ -	o ₂ -					
20	1FK7011-5	155 (6.10)	89 (3.50)	118 (4.65)	155 (6.10)	89 (3.50)	118 (4.65)	155 (6.10)	89 (3.50)	118 (4.65)	155 (6.10)	89 (3.50)	118 (4.65)	8 (0.31)	-	18 (0.71)	8.8 (0.35)	2 (0.08)											
	1FK7015-5	180 (7.09)	114 (4.49)	143 (5.63)	180 (7.09)	114 (4.49)	143 (5.63)	180 (7.09)	114 (4.49)	143 (5.63)	180 (7.09)	114 (4.49)	143 (5.63)																
28	1FK7022-5	178 (7.01)	95 (3.74)	128 (5.04)	200 (7.87)	95 (3.74)	150 (5.91)	178 (7.01)	95 (3.74)	128 (5.04)	200 (7.87)	95 (3.74)	150 (5.91)	9 (0.35)	M3	20 (0.79)	10.2 (0.40)	3 (0.12)											
	1FK7032-5	175 (6.89)	90 (3.54)	125 (4.92)	200 (7.87)	90 (3.54)	149 (5.87)	175 (6.89)	90 (3.54)	125 (4.92)	200 (7.87)	90 (3.54)	149 (5.87)																
36	1FK7032-5	200 (7.87)	115 (4.53)	150 (5.91)	225 (8.86)	115 (4.53)	174 (6.85)	200 (7.87)	115 (4.53)	150 (5.91)	225 (8.86)	115 (4.53)	174 (6.85)	14 (0.55)	M5	30 (1.18)	16 (0.63)	5 (0.20)											
	1FK7034-5	200 (7.87)	115 (4.53)	150 (5.91)	225 (8.86)	115 (4.53)	174 (6.85)	200 (7.87)	115 (4.53)	150 (5.91)	225 (8.86)	115 (4.53)	174 (6.85)																
48	1FK7040-5	155 (6.10)	73 (2.87)	106 (4.17)	184 (7.24)	73 (2.87)	135 (5.31)	163 (6.42)	73 (2.87)	106 (4.17)	192 (7.56)	73 (2.87)	135 (5.31)	19 (0.75)	M6	40 (1.57)	21.5 (0.85)	6 (0.24)											
	1FK7042-5	182 (7.17)	101 (3.98)	134 (5.28)	211 (8.31)	101 (3.98)	163 (6.42)	191 (7.52)	101 (3.98)	134 (5.28)	220 (8.66)	101 (3.98)	163 (6.42)																
63	1FK7060-5	180 (7.09)	94 (3.70)	126 (4.96)	223 (8.78)	94 (3.70)	169 (6.65)	188 (7.40)	94 (3.70)	126 (4.96)	231 (9.09)	94 (3.70)	169 (6.65)	24 (0.94)	M8	50 (1.97)	27 (1.06)	8 (0.31)											
	1FK7063-5	225 (8.86)	139 (5.47)	171 (6.73)	268 (10.55)	139 (5.47)	214 (8.43)	233 (9.17)	139 (5.47)	171 (6.73)	276 (10.87)	139 (5.47)	214 (8.43)																

1FK701.-5
1FK702.-5
1FK703.-5
1FK704.-5
1FK706.-5

Shaft version
with fitted key

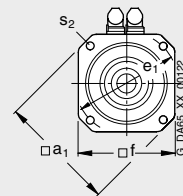
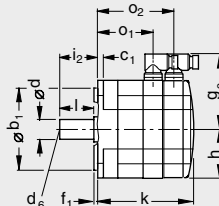
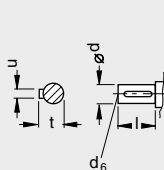

Synchronous motors

Dimension drawings

1FK7 Compact motors without/with DRIVE-CLiQ Natural cooling

For motor		Dimensions in mm (in)											Encoder system: Resolver					
Shaft height	Type	DIN IEC	a ₁ P	b ₁ N	c ₁ LA	e ₁ M	f AB	f ₁ T	g ₂ -	h H	i ₂ -	s ₂ S	Without brake			With brake		
													k LB	o ₁ -	o ₂ -	k LB	o ₁ -	o ₂ -
1FK7 Compact, type IM B5, natural cooling, with connector, without/with brake																		
80	1FK7080-5		186 (7.32)	130 (5.12)	13 (0.51)	165 (6.50)	155 (6.10)	3.5 (0.14)	119.5 (4.70)	77.5 (3.05)	58 (2.28)	11 (0.43)	156 (6.14)	91 (3.58)	124 (4.88)	184 (7.24)	91 (3.58)	151 (5.94)
	1FK7083-5												194 (7.64)	129 (5.08)	162 (6.38)	245 (9.65)	129 (5.08)	207 (8.15)
100	1FK7100-5		240 (9.45)	180 (7.09)	13 (0.51)	215 (8.46)	192 (7.56)	4 (0.16)	138 (5.43)	96 (3.78)	80 (3.15)	14 (0.55)	185 (7.28)	113 (4.45)	153 (6.02)	204 (8.03)	113 (4.45)	172 (6.77)
	1FK7101-5												211 (8.31)	139 (5.47)	179 (7.05)	240 (9.45)	139 (5.47)	208 (8.19)
	1FK7103-5												237 (9.33)	165 (6.50)	205 (8.07)	266 (10.47)	165 (6.50)	234 (9.21)
	1FK7105-5												289 (11.38)	217 (8.54)	257 (10.12)	318 (12.52)	217 (8.54)	286 (11.26)

Shaft height	Type	Encoder system:											DE shaft extension					
		Without brake			With brake			Without brake			With brake			d D	d ₆ -	l E	t GA	u F
		k LB	o ₁ -	o ₂ -	k LB	o ₁ -	o ₂ -	k LB	o ₁ -	o ₂ -	k LB	o ₁ -	o ₂ -					
		Incremental encoder sin/cos1 V _{pp} Incremental encoder 22 bit (2048 S/R) Absolute encoder EnDat 32 S/R Absolute encoder 16 bit (32 S/R)																
		Absolute encoder EnDat 2048 S/R Absolute encoder 22 bit (2048 S/R)																
80	1FK7080-5	179 (7.05)	91 (3.58)	124 (4.88)	206 (8.11)	91 (3.58)	151 (5.94)	187 (7.36)	91 (3.58)	124 (4.88)	215 (8.46)	91 (3.58)	151 (5.94)	32 (1.26)	M12	58 (2.28)	35 (1.38)	10 (0.39)
	1FK7083-5	217 (8.54)	129 (5.08)	162 (6.38)	268 (10.55)	153 (6.02)	213 (8.39)	225 (8.86)	129 (5.08)	162 (6.38)	276 (10.87)	129 (5.08)	207 (8.15)					
100	1FK7100-5	208 (8.19)	113 (4.45)	153 (6.02)	227 (8.94)	113 (4.45)	172 (6.77)	216 (8.50)	113 (4.45)	153 (6.02)	235 (9.25)	113 (4.45)	172 (6.77)	38 (1.50)	M12	80 (3.15)	41 (1.61)	10 (0.39)
	1FK7101-5	234 (9.21)	139 (5.47)	179 (7.05)	263 (10.35)	139 (5.47)	208 (8.19)	242 (9.53)	139 (5.47)	179 (7.05)	271 (10.67)	139 (5.47)	208 (8.19)					
	1FK7103-5	260 (10.24)	165 (6.50)	205 (8.07)	289 (11.38)	165 (6.50)	234 (9.21)	268 (10.55)	165 (6.50)	205 (8.07)	297 (11.69)	165 (6.50)	234 (9.21)					
	1FK7105-5	312 (12.28)	217 (8.54)	257 (10.12)	341 (13.43)	217 (8.54)	286 (11.26)	320 (12.60)	217 (8.54)	257 (10.12)	349 (13.74)	217 (8.54)	286 (11.26)					

1FK708.-5

Shaft version with fitted key

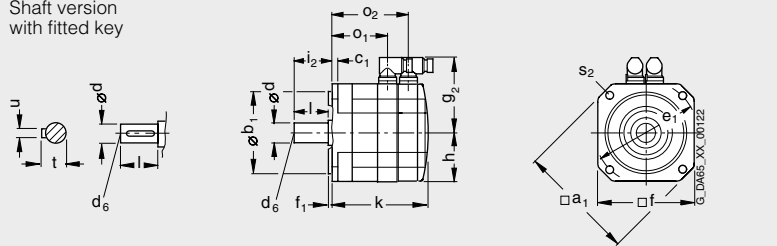

**1FK7100-5
1FK7101-5
1FK7103-5
1FK7105-5**

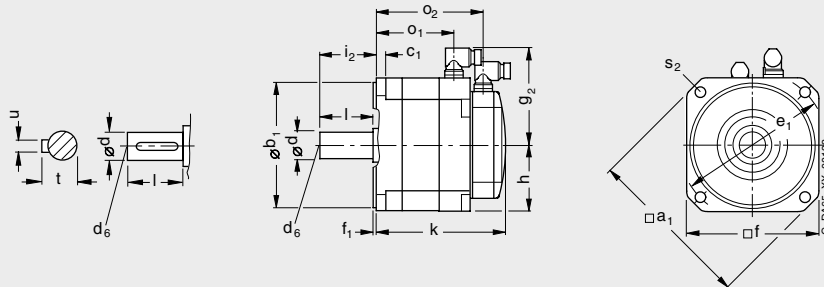

Synchronous motors Dimension drawings

1FK7 High Dynamic motors without/with DRIVE-CLiQ Natural cooling

For motor Dimensions in mm (in)

Shaft height	Type	DIN IEC	a ₁ P	b ₁ N	c ₁ LA	e ₁ M	f AB	f ₁ T	g ₂ -	h H	i ₂ -	s ₂ S	Encoder system:		
													k LB	o ₁ -	o ₂ -
1FK7 High Dynamic, type IM B5, natural cooling, with connector, without/with brake															
36	1FK7033-7		92 (3.62)	60 (2.36)	8 (0.31)	75 (2.95)	72 (2.83)	3 (0.12)	78 (3.07)	36 (1.42)	30 (1.18)	6.5 (0.26)	170/195 (6.69/7.68)	108/108 (4.25/4.25)	145/170 (5.71/6.69)
48	1FK7043-7		120 (4.72)	80 (3.15)	10 (0.39)	100 (3.94)	96 (3.78)	3 (0.12)	90 (3.54)	48 (1.89)	40 (1.57)	7 (0.28)	191/220 (7.52/8.66)	130/130 (5.12/5.12)	163/192 (6.42/7.56)
	1FK7044-7												216/245 (8.51/9.65)	155/155 (6.10/6.10)	188/217 (7.40/8.54)
63	1FK7061-7		155 (6.10)	110 (4.33)	10 (0.39)	130 (5.12)	126 (4.96)	3.5 (0.14)	105 (4.13)	63 (2.48)	50 (1.97)	9 (0.35)	185/228 (7.28/8.98)	121/121 (4.76/4.76)	153/196 (6.02/7.72)
	1FK7064-7												249/292 (9.80/11.50)	185/185 (7.28/7.28)	217/260 (8.54/10.24)
80	1FK7085-7		186 (7.32)	130 (5.12)	13 (0.51)	165 (6.50)	155 (6.10)	3.5 (0.14)	141.5 (5.57)	77.5 (3.05)	60 (2.36)	11 (0.43)	261/304 (10.28/11.97)	190/191 (7.48/7.52)	229/272 (9.02/10.71)
	1FK7086-7								140.5 (5.53)				261/303 (10.28/11.93)	192/192 (7.56/7.56)	

Shaft height	Type	DIN IEC	Encoder system:						DE shaft extension				
			k LB	o ₁ -	o ₂ -	k LB	o ₁ -	o ₂ -	d D	d ₆ -	l E	t GA	u F
			Incremental encoder sin/cos1 V _{DD}			Absolute encoder EnDat 2048 S/R							
			Incremental encoder 22 bit (2048 S/R)			Absolute encoder 22 bit (2048 S/R)							
			Absolute encoder EnDat 32 S/R			Absolute encoder EnDat 512 S/R							
			Absolute encoder 16 bit (32 S/R)			Absolute encoder 20 bit (512 S/R)							
			Without/with brake			Without/with brake							
36	1FK7033-7		194/219 (7.64/8.62)	109/109 (4.29/4.29)	144/168 (5.67/6.61)	194/219 (7.64/8.62)	109/109 (4.29/4.29)	144/168 (5.67/6.61)	14 (0.55)	M5	30 (1.18)	16 (0.63)	5 (0.20)
48	1FK7043-7		212/241 (8.35/9.49)	130/130 (5.12/5.12)	163/192 (6.42/7.56)	220/249 (8.66/9.80)	130/130 (5.12/5.12)	163/192 (6.42/7.56)	19 (0.75)	M6	40 (1.57)	21.5 (0.85)	6 (0.24)
	1FK7044-7		237/266 (9.33/10.47)	155/155 (6.10/6.10)	188/217 (7.40/8.54)	245/274 (9.65/10.79)	155/155 (6.10/6.10)	188/217 (7.40/8.54)					
63	1FK7061-7		208/251 (8.19/9.88)	121/121 (4.76/4.76)	154/197 (6.06/7.76)	217/260 (8.54/10.24)	121/121 (4.76/4.76)	154/197 (6.06/7.76)	24 (0.94)	M6	50 (1.97)	27 (1.06)	8 (0.31)
	1FK7064-7		272/315 (10.71/12.40)	185/185 (7.28/7.28)	218/261 (8.58/10.28)	281/324 (11.06/12.76)	185/185 (7.28/7.28)	218/261 (8.58/10.28)					
80	1FK7085-7		283/326 (11.14/12.83)	192/192 (7.56/7.56)	229/272 (9.02/10.71)	292/334 (11.50/13.15)	192/192 (7.56/7.56)	229/272 (9.02/10.71)	32 (1.26)	M12	58 (2.28)	35 (1.38)	10 (0.39)
	1FK7086-7												

1FK703-7
1FK704-7
1FK706-7
1FK708-7

Shaft version with fitted key

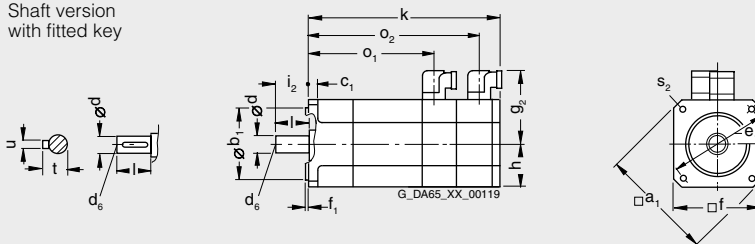

Synchronous motors

Dimension drawings

1FT6 motors without/with DRIVE-CLiQ with SP+ planetary gearbox, single-stage

For motor		Dimensions in mm (in)										Encoder system:				
Shaft height	Type	F4	Planetary gearbox Type	D1	D2	D3	D4	L5	L6	L7	L8	Resolver		Incremental encoder Absolute encoder		
												Without brake K	With brake K	Without brake K	With brake K	
1FT6 with SP+ planetary gearbox, single-stage, type IM B5, natural cooling, with connector, without/with brake																
28	1FT6021	62 (2.44)	SP060S-MF1	60 (2.36)	16 (0.63)	5.5 (0.22)	68 (2.68)	138 (5.44)	28 (1.10)	20 (0.79)	6 (0.24)	283	308	283	308	
	1FT6024											(11.15)	(12.14)	(11.15)	(12.14)	
												323	348	323	348	
												(12.73)	(13.71)	(12.73)	(13.71)	
36	1FT6031	62 (2.44)	SP060S-MF1	60 (2.36)	16 (0.63)	5.5 (0.22)	68 (2.68)	142 (5.59)	28 (1.10)	20 (0.79)	6 (0.24)	274	294	314	334	
	1FT6034											(10.80)	(11.58)	(12.37)	(13.16)	
												314	334	354	374	
												(12.37)	(13.16)	(13.95)	(14.74)	
48	1FT6041	76 (2.99)	SP075S-MF1	70 (2.76)	22 (0.87)	6.6 (0.26)	85 (3.35)	164 (6.46)	36 (1.42)	20 (0.79)	7 (0.28)	328	348	368	388	
	1FT6044											(12.92)	(13.71)	(14.50)	(15.29)	
												297	332	340	375	
												(11.70)	(13.08)	(13.40)	(14.78)	
												347	382	390	425	
												(13.67)	(15.05)	(15.37)	(16.75)	
63	1FT6061	101 (3.98)	SP100S-MF1	90 (3.55)	32 (1.26)	9 (0.35)	120 (4.73)	217 (8.55)	58 (2.29)	30 (1.18)	10 (0.39)	327	357	357	387	
	1FT6062											(12.88)	(14.07)	(14.07)	(15.25)	
												352	382	382	412	
												(13.87)	(15.05)	(15.05)	(16.23)	
												402	432	432	462	
												(15.84)	(17.02)	(17.02)	(18.20)	
80	1FT6081	141 (5.56)	SP140S-MF1	130 (5.12)	40 (1.58)	11 (0.43)	165 (6.50)	283 (11.15)	82 (3.23)	30 (1.18)	12 (0.47)	392	419	392	419	
	1FT6082											(15.44)	(16.51)	(15.44)	(16.51)	
												417	444	417	444	
												(16.43)	(17.49)	(16.43)	(17.49)	
												467	513	467	513	
												(18.40)	(20.21)	(18.40)	(20.21)	
												517	563	517	563	
												(20.37)	(22.18)	(20.37)	(22.18)	
	1FT6086	182 (7.17)	SP180S-MF1	160 (6.30)	55 (2.17)	13.5 (0.53)	215 (8.47)	310 (12.21)	82 (3.23)	30 (1.18)	15 (0.59)	544	590	544	590	
												(21.43)	(23.25)	(21.43)	(23.25)	

1FT602
1FT603
1FT604
1FT606
1FT608

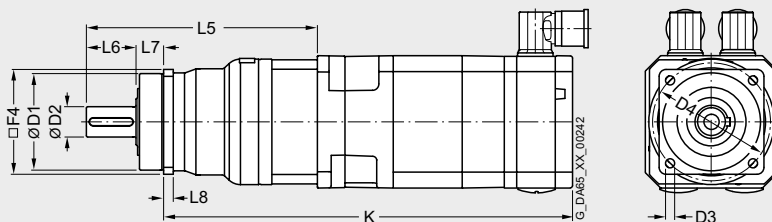

Synchronous motors

Dimension drawings

1FT6 motors without/with DRIVE-CLiQ with SP+ planetary gearbox, single-stage

For motor		Dimensions in mm (in)										Encoder system:				
Shaft height	Type	F4	Planetary gearbox Type	D1	D2	D3	D4	L5	L6	L7	L8	Resolver		Incremental encoder Absolute encoder		
												Without brake K	With brake K	Without brake K	With brake K	
1FT6 with SP+ planetary gearbox, single-stage, type IM B5, natural cooling, with connector, without/with brake																
100	1FT6102	182	SP180S-MF1	160	55	13.5	215	310	82	30	15	493	539	493	539	
		(7.17)		(6.30)	(2.17)	(0.53)	(8.47)	(12.21)	(3.23)	(1.18)	(0.59)	(19.42)	(21.24)	(19.42)	(21.24)	
	1FT6105											568	614	568	614	
												(22.38)	(24.19)	(22.38)	(24.19)	
	1FT6105	212	SP210-MF1	180	75	17	250	350	105	38	17	577	623	577	623	
		(8.35)		(7.09)	(2.96)	(0.67)	(9.85)	(13.79)	(4.14)	(1.50)	(0.67)	(22.73)	(24.55)	(22.73)	(24.55)	
100	1FT6108	182	SP180S-MF1	160	55	13.5	215	310	82	30	15	668	714	668	714	
		(7.17)		(6.30)	(2.17)	(0.53)	(8.47)	(12.21)	(3.23)	(1.18)	(0.59)	(26.32)	(28.13)	(26.32)	(28.13)	
	1FT6108	212	SP210-MF1	180	75	17	250	350	105	38	17	677	723	677	723	
		(8.35)		(7.09)	(2.96)	(0.67)	(9.85)	(13.79)	(4.14)	(1.50)	(0.67)	(26.67)	(28.49)	(26.67)	(28.49)	
	132	1FT6132	212	SP210-MF1	180	75	17	250	350	105	38	17	630	680	630	680
			(8.35)		(7.09)	(2.96)	(0.67)	(9.85)	(13.79)	(4.14)	(1.50)	(0.67)	(24.82)	(26.79)	(24.82)	(26.79)
1FT6134												680	730	680	730	
												(26.79)	(28.76)	(26.79)	(28.76)	
132	1FT6134	242	SP240-MF1	200	85	17	290	436	130	40	20	739	789	739	789	
		(9.53)		(7.88)	(3.35)	(0.67)	(11.43)	(17.18)	(5.12)	(1.58)	(0.79)	(29.12)	(31.09)	(29.12)	(31.09)	
	1FT6136	212	SP210-MF1	180	75	17	250	350	105	38	17	730	780	730	780	
		(8.35)		(7.09)	(2.96)	(0.67)	(9.85)	(13.79)	(4.14)	(1.50)	(0.67)	(28.76)	(30.73)	(28.76)	(30.73)	
132	1FT6136	242	SP240-MF1	200	85	17	290	436	130	40	20	789	839	789	839	
		(9.53)		(7.88)	(3.35)	(0.67)	(11.43)	(17.18)	(5.12)	(1.58)	(0.79)	(31.09)	(33.06)	(31.09)	(33.06)	

1FT610
1FT613

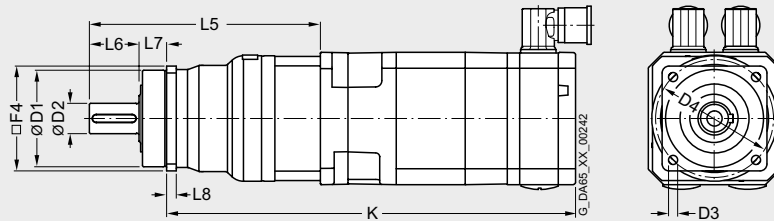

Synchronous motors

Dimension drawings

1FT6 motors without/with DRIVE-CLiQ with SP+ planetary gearbox, two-stage

For motor		Dimensions in mm (in)										Encoder system:				
Shaft height	Type	F4	Planetary gearbox Type	D1	D2	D3	D4	L5	L6	L7	L8	Resolver		Incremental encoder Absolute encoder		
												Without brake K	With brake K	Without brake K	With brake K	
1FT6 with SP+ planetary gearbox, two-stage, type IM B5, natural cooling, with connector, without/with brake																
28	1FT6021	62	SP060S-MF2	60	16	5.5	68	156	28	20	6	301	326	301	326	
		(2.44)		(2.36)	(0.63)	(0.22)	(2.68)	(6.15)	(1.10)	(0.79)	(0.24)	(11.86)	(12.84)	(11.86)	(12.84)	
	1FT6021	76	SP075S-MF2	70	22	6.6	85	175	36	20	7	312	337	312	337	
		(2.99)		(2.76)	(0.87)	(0.26)	(3.35)	(6.90)	(1.42)	(0.79)	(0.28)	(12.29)	(13.28)	(12.29)	(13.28)	
	1FT6024	62	SP060S-MF2	60	16	5.5	68	156	28	20	6	341	366	341	366	
		(2.44)		(2.36)	(0.63)	(0.22)	(2.68)	(6.15)	(1.10)	(0.79)	(0.24)	(13.44)	(14.42)	(13.44)	(14.42)	
	1FT6024	76	SP075S-MF2	70	22	6.6	85	175	36	20	7	352	377	352	377	
		(2.99)		(2.76)	(0.87)	(0.26)	(3.35)	(6.90)	(1.42)	(0.79)	(0.28)	(13.87)	(14.85)	(13.87)	(14.85)	
	1FT6024	101	SP100S-MF2	90	32	9	120	230	58	30	10	375	400	375	400	
		(3.98)		(3.55)	(1.26)	(0.35)	(4.73)	(9.06)	(2.29)	(1.18)	(0.39)	(14.78)	(15.76)	(14.78)	(15.76)	
36	1FT6031	62	SP060S-MF2	60	16	5.5	68	164	28	20	6	296	316	336	356	
		(2.44)		(2.36)	(0.63)	(0.22)	(2.68)	(6.46)	(1.10)	(0.79)	(0.24)	(11.66)	(12.45)	(13.24)	(14.03)	
	1FT6031	76	SP075S-MF2	70	22	6.6	85	179	36	20	7	303	323	343	363	
		(2.99)		(2.76)	(0.87)	(0.26)	(3.35)	(7.05)	(1.42)	(0.79)	(0.28)	(11.94)	(12.73)	(13.51)	(14.30)	
	1FT6031	101	SP100S-MF2	90	32	9	120	230	58	30	10	322	342	362	382	
		(3.98)		(3.55)	(1.26)	(0.35)	(4.73)	(9.06)	(2.29)	(1.18)	(0.39)	(12.69)	(13.47)	(14.26)	(15.05)	
	1FT6034	76	SP075S-MF2	70	22	6.6	85	179	36	20	7	343	363	383	403	
		(2.99)		(2.76)	(0.87)	(0.26)	(3.35)	(7.05)	(1.42)	(0.79)	(0.28)	(13.51)	(14.30)	(15.09)	(15.88)	
	1FT6034	101	SP100S-MF2	90	32	9	120	230	58	30	10	362	382	402	422	
		(3.98)		(3.55)	(1.26)	(0.35)	(4.73)	(9.06)	(2.29)	(1.18)	(0.39)	(14.26)	(15.05)	(15.84)	(16.63)	
	1FT6034	141	SP140S-MF2	130	40	11	165	298	82	30	12	406	426	446	466	
		(5.56)		(5.12)	(1.58)	(0.43)	(6.50)	(11.74)	(3.23)	(1.18)	(0.47)	(16.00)	(16.78)	(17.57)	(18.36)	
48	1FT6041	76	SP075S-MF2	70	22	6.6	85	192	36	20	7	321	356	364	399	
		(2.99)		(2.76)	(0.87)	(0.26)	(3.35)	(7.56)	(1.42)	(0.79)	(0.28)	(12.65)	(14.03)	(14.34)	(15.72)	
	1FT6041	101	SP100S-MF2	90	32	9	120	234	58	30	10	331	366	374	409	
		(3.98)		(3.55)	(1.26)	(0.35)	(4.73)	(9.22)	(2.29)	(1.18)	(0.39)	(13.04)	(14.42)	(14.74)	(16.11)	
	1FT6041	141	SP140S-MF2	130	40	11	165	298	82	30	12	371	406	414	449	
		(5.56)		(5.12)	(1.58)	(0.43)	(6.50)	(11.74)	(3.23)	(1.18)	(0.47)	(14.62)	(16.00)	(16.31)	(17.69)	
	1FT6044	101	SP100S-MF2	90	32	9	120	234	58	30	10	381	416	424	459	
		(3.98)		(3.55)	(1.26)	(0.35)	(4.73)	(9.22)	(2.29)	(1.18)	(0.39)	(15.01)	(16.39)	(16.71)	(18.08)	
	1FT6044	141	SP140S-MF2	130	40	11	165	298	82	30	12	421	456	464	499	
		(5.56)		(5.12)	(1.58)	(0.43)	(6.50)	(11.74)	(3.23)	(1.18)	(0.47)	(16.59)	(17.97)	(18.28)	(19.66)	
	1FT6044	182	SP180S-MF2	160	55	13.5	215	346	82	30	15	469	504	512	547	
		(7.17)		(6.30)	(2.17)	(0.53)	(8.47)	(13.63)	(3.23)	(1.18)	(0.59)	(18.48)	(19.86)	(20.17)	(21.55)	

1FT602
1FT603
1FT604

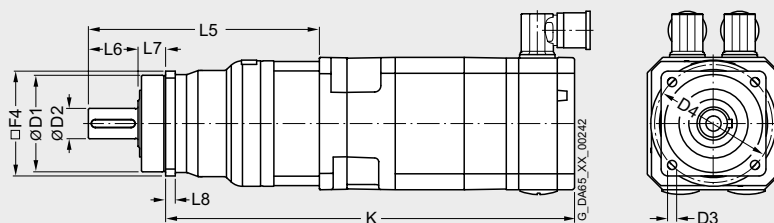

Synchronous motors Dimension drawings

1FT6 motors without/with DRIVE-CLiQ with SP+ planetary gearbox, two-stage

For motor		Dimensions in mm (in)										Encoder system:				
Shaft height	Type	F4	Planetary gearbox Type	D1	D2	D3	D4	L5	L6	L7	L8	Resolver		Incremental encoder Absolute encoder		
												Without brake K	With brake K	Without brake K	With brake K	
1FT6 with SP+ planetary gearbox, two-stage, type IM B5, natural cooling, with connector, without/with brake																
63	1FT6061	101	SP100S-MF2	90	32	9	120	252	58	30	10	362	392	392	422	
		(3.98)		(3.55)	(1.26)	(0.35)	(4.73)	(9.93)	(2.29)	(1.18)	(0.39)	(14.26)	(15.44)	(15.44)	(16.63)	
	1FT6061	141	SP140S-MF2	130	40	11	165	305	82	30	12	391	421	421	451	
		(5.56)		(5.12)	(1.58)	(0.43)	(6.50)	(12.02)	(3.23)	(1.18)	(0.47)	(15.41)	(16.59)	(16.59)	(17.77)	
	1FT6061	182	SP180S-MF2	160	55	13.5	215	346	82	30	15	432	462	462	492	
		(7.17)		(6.30)	(2.17)	(0.53)	(8.47)	(13.63)	(3.23)	(1.18)	(0.59)	(17.02)	(18.20)	(18.20)	(19.38)	
	1FT6062	101	SP100S-MF2	90	32	9	120	252	58	30	10	387	417	417	447	
		(3.98)		(3.55)	(1.26)	(0.35)	(4.73)	(9.93)	(2.29)	(1.18)	(0.39)	(15.25)	(16.43)	(16.43)	(17.61)	
	1FT6062	141	SP140S-MF2	130	40	11	165	305	82	30	12	416	446	446	476	
		(5.56)		(5.12)	(1.58)	(0.43)	(6.50)	(12.02)	(3.23)	(1.18)	(0.47)	(16.39)	(17.57)	(17.57)	(18.75)	
	1FT6064	101	SP100S-MF2	90	32	9	120	252	58	30	10	437	467	467	497	
		(3.98)		(3.55)	(1.26)	(0.35)	(4.73)	(9.93)	(2.29)	(1.18)	(0.39)	(17.22)	(18.40)	(18.40)	(19.58)	
1FT6064	141	SP140S-MF2	130	40	11	165	305	82	30	12	466	496	496	526		
	(5.56)		(5.12)	(1.58)	(0.43)	(6.50)	(12.02)	(3.23)	(1.18)	(0.47)	(18.36)	(19.54)	(19.54)	(20.72)		
1FT6064	182	SP180S-MF2	160	55	13.5	215	346	82	30	15	507	537	537	567		
	(7.17)		(6.30)	(2.17)	(0.53)	(8.47)	(13.63)	(3.23)	(1.18)	(0.59)	(19.98)	(21.16)	(21.16)	(22.34)		
80	1FT6081	141	SP140S-MF2	130	40	11	165	332	82	30	12	441	468	441	468	
		(5.56)		(5.12)	(1.58)	(0.43)	(6.50)	(13.08)	(3.23)	(1.18)	(0.47)	(17.38)	(18.44)	(17.38)	(18.44)	
	1FT6081	182	SP180S-MF2	160	55	13.5	215	355	82	30	15	464	491	464	491	
		(7.17)		(6.30)	(2.17)	(0.53)	(8.47)	(13.99)	(3.23)	(1.18)	(0.59)	(18.28)	(19.35)	(18.28)	(19.35)	
	1FT6081	212	SP210-MF2	180	75	17	250	397	105	38	17	475	502	475	502	
		(8.35)		(7.09)	(2.96)	(0.67)	(9.85)	(15.64)	(4.14)	(1.50)	(0.67)	(18.72)	(19.78)	(18.72)	(19.78)	
	1FT6082	141	SP140S-MF2	130	40	11	165	332	82	30	12	466	493	466	493	
		(5.56)		(5.12)	(1.58)	(0.43)	(6.50)	(13.08)	(3.23)	(1.18)	(0.47)	(18.36)	(19.42)	(18.36)	(19.42)	
	1FT6082	182	SP180S-MF2	160	55	13.5	215	355	82	30	15	489	516	489	516	
		(7.17)		(6.30)	(2.17)	(0.53)	(8.47)	(13.99)	(3.23)	(1.18)	(0.59)	(19.27)	(20.33)	(19.27)	(20.33)	
	1FT6082	212	SP210-MF2	180	75	17	250	397	105	38	17	500	527	500	527	
		(8.35)		(7.09)	(2.96)	(0.67)	(9.85)	(15.64)	(4.14)	(1.50)	(0.67)	(19.70)	(20.76)	(19.70)	(20.76)	
1FT6084	141	SP140S-MF2	130	40	11	165	332	82	30	12	516	562	516	562		
	(5.56)		(5.12)	(1.58)	(0.43)	(6.50)	(13.08)	(3.23)	(1.18)	(0.47)	(20.33)	(22.14)	(20.33)	(22.14)		
1FT6084	182	SP180S-MF2	160	55	13.5	215	355	82	30	15	539	585	539	585		
	(7.17)		(6.30)	(2.17)	(0.53)	(8.47)	(13.99)	(3.23)	(1.18)	(0.59)	(21.24)	(23.05)	(21.24)	(23.05)		
1FT6084	242	SP240-MF2	200	85	17	290	454	130	40	20	580	626	580	626		
	(9.53)		(7.88)	(3.35)	(0.67)	(11.43)	(17.89)	(5.12)	(1.58)	(0.79)	(22.85)	(24.66)	(22.85)	(24.66)		
1FT6086	141	SP140S-MF2	130	40	11	165	332	82	30	12	566	612	566	612		
	(5.56)		(5.12)	(1.58)	(0.43)	(6.50)	(13.08)	(3.23)	(1.18)	(0.47)	(22.30)	(24.11)	(22.30)	(24.11)		
1FT6086	182	SP180S-MF2	160	55	13.5	215	355	82	30	15	589	635	589	635		
	(7.17)		(6.30)	(2.17)	(0.53)	(8.47)	(13.99)	(3.23)	(1.18)	(0.59)	(23.21)	(25.02)	(23.21)	(25.02)		

1FT606
1FT608

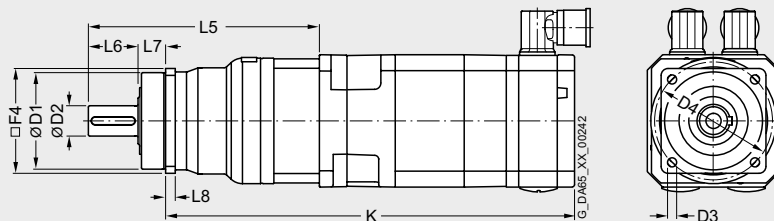

6

Synchronous motors

Dimension drawings

1FT6 motors without/with DRIVE-CLiQ with SP+ planetary gearbox, two-stage

For motor		Dimensions in mm (in)										Encoder system:				
Shaft height	Type	F4	Planetary gearbox Type	D1	D2	D3	D4	L5	L6	L7	L8	Resolver		Incremental encoder Absolute encoder		
												Without brake K	With brake K	Without brake K	With brake K	
1FT6 with SP+ planetary gearbox, two-stage, type IM B5, natural cooling, with connector, without/with brake																
100	1FT6102	182	SP180S-MF2	160	55	13.5	215	355	82	30	15	538	584	538	584	
		(7.17)		(6.30)	(2.17)	(0.53)	(8.47)	(13.99)	(3.23)	(1.18)	(0.59)	(21.20)	(23.01)	(21.20)	(23.01)	
	1FT6102	242	SP240-MF2	200	85	17	290	454	130	40	20	579	625	579	625	
		(9.53)		(7.88)	(3.35)	(0.67)	(11.43)	(17.89)	(5.12)	(1.58)	(0.79)	(22.81)	(24.63)	(22.81)	(24.63)	
	1FT6105	212	SP210-MF2	180	75	17	250	397	105	38	17	624	670	624	670	
	(8.35)		(7.09)	(2.96)	(0.67)	(9.85)	(15.64)	(4.14)	(1.50)	(0.67)	(24.59)	(26.40)	(24.59)	(26.40)		
	1FT6105	242	SP240-MF2	200	85	17	290	454	130	40	20	654	700	654	700	
		(9.53)		(7.88)	(3.35)	(0.67)	(11.43)	(17.89)	(5.12)	(1.58)	(0.79)	(25.77)	(27.58)	(25.77)	(27.58)	
	1FT6108	242	SP240-MF2	200	85	17	290	454	130	40	20	754	800	754	800	
		(9.53)		(7.88)	(3.35)	(0.67)	(11.43)	(17.89)	(5.12)	(1.58)	(0.79)	(29.71)	(31.52)	(29.71)	(31.52)	
132	1FT6132	212	SP210-MF2	180	75	17	250	397	105	38	170	677	727	677	727	
		(8.35)		(7.09)	(2.96)	(0.67)	(9.85)	(15.64)	(4.14)	(1.50)	(6.70)	(26.67)	(28.64)	(26.67)	(28.64)	
	1FT6134	242	SP240-MF2	200	85	17	290	454	130	40	20	757	807	757	807	
		(9.53)		(7.88)	(3.35)	(0.67)	(11.43)	(17.89)	(5.12)	(1.58)	(0.79)	(29.83)	(31.80)	(29.83)	(31.80)	
	1FT6136											807	857	807	857	
												(31.80)	(33.77)	(31.80)	(33.77)	

1FT610
1FT613

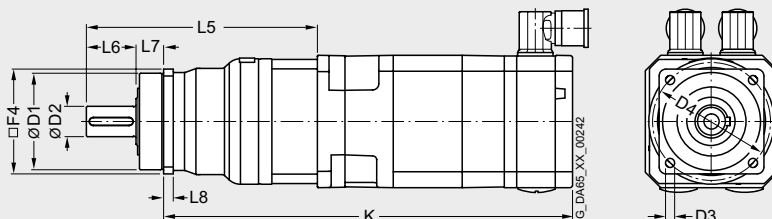

Synchronous motors Dimension drawings

1FK7 Compact motors without/with DRIVE-CLiQ with SP+ planetary gearbox, single-stage

For motor		Dimensions in mm (in)											Encoder system:							
Shaft height	Type	F4	Planetary gearbox Type	D1	D2	D3	D4	L5	L6	L7	L8	Without brake		With brake		Without brake		With brake		
												K	K	K	K	K	K			
1FK7 Compact with SP+ planetary gearbox, single-stage, type IM B5, natural cooling, with connector, without/with brake																				
28	1FK7022-5	62 (2.44)	SP060S-MF1	60 (2.36)	16 (0.63)	6 (0.24)	68 (2.68)	137 (5.40)	28 (1.10)	20 (0.79)	6 (0.24)	242 (9.53)	264 (10.40)	267 (10.52)	289 (11.39)	267 (10.52)	289 (11.39)	Resolver	Incremental encoder sin/cos 1 V _{pp}	Absolute encoder EnDat 2048 S/R
36	1FK7032-5	62 (2.44)	SP060S-MF1	60 (2.36)	16 (0.63)	6 (0.24)	68 (2.68)	142 (5.59)	28 (1.10)	20 (0.79)	6 (0.24)	244 (9.61)	269 (10.60)	269 (10.60)	294 (11.58)	269 (10.60)	294 (11.58)	Absolute encoder 22 bit (2048 S/R)	Absolute encoder EnDat 512 S/R	Absolute encoder 20 bit (512 S/R)
48	1FK7040-5	76 (2.99)	SP075S-MF1	70 (2.76)	22 (0.87)	7 (0.28)	85 (3.35)	168 (6.62)	36 (1.42)	20 (0.79)	7 (0.28)	246 (9.69)	275 (10.84)	267 (10.52)	296 (11.66)	275 (10.84)	304 (11.98)	Incremental encoder 22 bit (2048 S/R)	Absolute encoder EnDat 32 S/R	Absolute encoder 16 bit (32 S/R)
	1FK7042-5												274 (10.80)	303 (11.94)	294 (11.58)	323 (12.73)	303 (11.94)	332 (13.08)		
63	1FK7060-5	101 (3.98)	SP100S-MF1	90 (3.55)	32 (1.26)	9 (0.35)	120 (4.73)	217 (8.55)	58 (2.29)	30 (1.18)	10 (0.39)	286 (11.27)	329 (12.96)	309 (12.17)	352 (13.87)	317 (12.49)	360 (14.18)			
	1FK7063-5												331 (13.04)	374 (14.74)	354 (13.98)	397 (15.64)	362 (14.26)	405 (15.96)		
80	1FK7080-5	141 (5.56)	SP140S-MF1	130 (5.12)	40 (1.58)	11 (0.43)	165 (6.50)	283 (11.15)	82 (3.23)	30 (1.18)	12 (0.47)	327 (12.88)	355 (13.95)	350 (13.79)	377 (14.85)	358 (14.11)	386 (15.21)			
	1FK7083-5												365 (14.38)	416 (16.39)	388 (15.29)	439 (17.30)	396 (15.60)	447 (17.61)		
100	1FK7100-5	182 (7.17)	SP180S-MF1	160 (6.30)	55 (2.17)	14 (0.55)	215 (8.47)	310 (12.21)	82 (3.23)	30 (1.18)	15 (0.59)	383 (15.09)	402 (15.84)	406 (16.00)	425 (16.75)	414 (16.31)	433 (17.06)			
	1FK7101-5												409 (16.11)	438 (17.26)	432 (17.02)	461 (18.16)	440 (17.34)	469 (18.48)		
	1FK7103-5											435 (17.14)	464 (18.28)	458 (18.05)	487 (19.19)	466 (18.36)	495 (19.50)			
	1FK7105-5	182 (7.17)	SP180S-MF1	160 (6.30)	55 (2.17)	14 (0.55)	215 (8.47)	310 (12.21)	82 (3.23)	30 (1.18)	15 (0.59)	487 (19.19)	516 (20.33)	510 (20.09)	539 (21.24)	518 (20.41)	547 (21.55)			
	1FK7105-5	212 (8.35)	SP210-MF1	180 (7.09)	75 (2.96)	17 (0.67)	250 (9.85)	350 (13.79)	105 (4.14)	38 (1.50)	17 (0.67)	496 (19.54)	525 (20.68)	519 (20.45)	548 (21.59)	527 (20.76)	556 (21.91)			

1FK702.-5
1FK703.-5
1FK704.-5
1FK706.-5
1FK708.-5
1FK710.-5

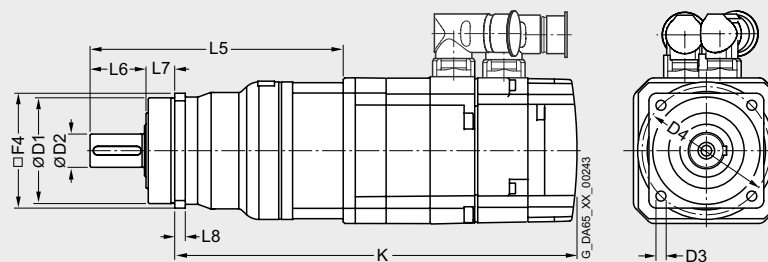

Synchronous motors

Dimension drawings

1FK7 High Dynamic motors without/with DRIVE-CLiQ with SP+ planetary gearbox, single-stage

For motor		Dimensions in mm (in)											Encoder system:					
Shaft height	Type	F4	Planetary gearbox Type	D1	D2	D3	D4	L5	L6	L7	L8	Resolver		Incremental encoder		Absolute encoder		
												Without brake	With brake	Without brake	With brake	Without brake	With brake	Without brake
												K	K	K	K	K	K	
1FK7 High Dynamic with SP+ planetary gearbox, single-stage, type IM B5, natural cooling, with connector, without/with brake																		
36	1FK7033-7	62 (2.44)	SP060S-MF1	60 (2.36)	16 (0.63)	6 (0.24)	68 (2.68)	142 (5.59)	28 (1.10)	20 (0.79)	6 (0.24)	263 (10.36)	288 (11.35)	288 (11.35)	313 (12.33)	288 (11.35)	313 (12.33)	
48	1FK7043-7 1FK7044-7	76 (2.99)	SP075S-MF1	70 (2.76)	22 (0.87)	7 (0.28)	85 (3.35)	168 (6.62)	36 (1.42)	20 (0.79)	7 (0.28)	303 (11.94)	332 (13.08)	324 (12.77)	353 (13.91)	332 (13.08)	361 (14.22)	
63	1FK7061-7 1FK7064-7	101 (3.98)	SP100S-MF1	90 (3.55)	32 (1.26)	9 (0.35)	120 (4.73)	217 (8.55)	58 (2.29)	30 (1.18)	10 (0.39)	314 (12.37)	357 (14.07)	337 (13.28)	380 (14.97)	346 (13.63)	389 (15.33)	
80	1FK7085-7 1FK7086-7	141 (5.56)	SP140S-MF1	130 (5.12)	40 (1.58)	11 (0.43)	165 (6.50)	283 (11.15)	82 (3.23)	30 (1.18)	12 (0.47)	432 (17.02)	474 (18.68)	454 (17.89)	497 (19.58)	463 (18.24)	505 (19.90)	

1FK703.-7
1FK704.-7
1FK706.-7
1FK708.-7

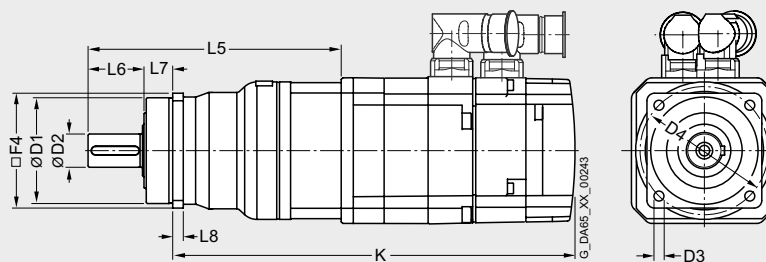

Synchronous motors

Dimension drawings

1FK7 Compact motors without/with DRIVE-CLiQ with SP+ planetary gearbox, two-stage

For motor		Dimensions in mm (in)											Encoder system:								
Shaft height	Type	F4	Planetary gearbox Type	D1	D2	D3	D4	L5	L6	L7	L8	Without brake		With brake		Without brake		With brake			
												K	K	K	K	K	K				
1FK7 Compact with SP+ planetary gearbox, two-stage, type IM B5, natural cooling, with connector, without/with brake																					
28	1FK7022-5	62	SP060S-MF2	60	16	5.5	68	156	28	20	6	261	283	286	308	286	308				
		(2.44)		(2.36)	(0.63)	(0.22)	(2.68)	(6.15)	(1.10)	(0.79)	(0.24)	(10.28)	(11.15)	(11.27)	(12.14)	(11.27)	(12.14)				
	1FK7022-5	76	SP075S-MF2	70	22	6.6	85	175	36	20	7	272	294	297	319	297	319				
	(2.99)		(2.76)	(0.87)	(0.26)	(3.35)	(6.90)	(1.42)	(0.79)	(0.28)	(10.72)	(11.58)	(11.70)	(12.57)	(11.70)	(12.57)					
	1FK7022-5	101	SP100S-MF2	90	32	9	120	230	58	30	10	295	317	320	342	320	342				
	(3.98)		(3.55)	(1.26)	(0.35)	(4.73)	(9.06)	(2.29)	(1.18)	(0.39)	(11.62)	(12.49)	(12.61)	(13.47)	(12.61)	(13.47)					
36	1FK7032-5	62	SP060S-MF2	60	16	5.5	68	164	28	20	6	266	291	291	316	291	316				
		(2.44)		(2.36)	(0.63)	(0.22)	(2.68)	(6.46)	(1.10)	(0.79)	(0.24)	(10.48)	(11.47)	(11.47)	(12.45)	(11.47)	(12.45)				
	1FK7032-5	76	SP075S-MF2	70	22	6.6	85	179	36	20	7	273	298	298	323	298	323				
	(2.99)		(2.76)	(0.87)	(0.26)	(3.35)	(7.05)	(1.42)	(0.79)	(0.28)	(10.76)	(11.74)	(11.74)	(12.73)	(11.74)	(12.73)					
	1FK7032-5	101	SP100S-MF2	90	32	9	120	230	58	30	10	292	317	317	342	317	342				
	(3.98)		(3.55)	(1.26)	(0.35)	(4.73)	(9.06)	(2.29)	(1.18)	(0.39)	(11.50)	(12.49)	(12.49)	(13.47)	(12.49)	(13.47)					
48	1FK7040-5	76	SP075S-MF2	70	22	6.6	85	192	36	20	7	270	299	291	320	299	328				
		(2.99)		(2.76)	(0.87)	(0.26)	(3.35)	(7.56)	(1.42)	(0.79)	(0.28)	(10.64)	(11.78)	(11.47)	(12.61)	(11.78)	(12.92)				
	1FK7040-5	101	SP100S-MF2	90	32	9	120	234	58	30	10	280	309	301	330	309	338				
		(3.98)		(3.55)	(1.26)	(0.35)	(4.73)	(9.22)	(2.29)	(1.18)	(0.39)	(11.03)	(12.17)	(11.86)	(13.00)	(12.17)	(13.32)				
	1FK7040-5	141	SP140S-MF2	130	40	11	165	298	82	30	12	320	349	341	370	349	378				
		(5.56)		(5.12)	(1.58)	(0.43)	(6.50)	(11.74)	(3.23)	(1.18)	(0.47)	(12.61)	(13.75)	(13.44)	(14.58)	(13.75)	(14.89)				
	1FK7042-5	76	SP075S-MF2	70	22	6.6	85	192	36	20	7	298	327	298	347	327	356				
	(2.99)		(2.76)	(0.87)	(0.26)	(3.35)	(7.56)	(1.42)	(0.79)	(0.28)	(11.74)	(12.88)	(11.74)	(13.67)	(12.88)	(14.03)					
	1FK7042-5	101	SP100S-MF2	90	32	9	120	234	58	30	10	308	337	308	357	337	366				
	(3.98)		(3.55)	(1.26)	(0.35)	(4.73)	(9.22)	(2.29)	(1.18)	(0.39)	(12.14)	(13.28)	(12.14)	(14.07)	(13.28)	(14.42)					
	1FK7042-5	141	SP140S-MF2	130	40	11	165	298	82	30	12	348	377	368	397	377	406				
	(5.56)		(5.12)	(1.58)	(0.43)	(6.50)	(11.74)	(3.23)	(1.18)	(0.47)	(13.71)	(14.85)	(14.50)	(15.64)	(14.85)	(16.00)					
63	1FK7060-5	101	SP100S-MF2	90	32	9	120	252	58	30	10	321	364	344	387	352	395				
		(3.98)		(3.55)	(1.26)	(0.35)	(4.73)	(9.93)	(2.29)	(1.18)	(0.39)	(12.65)	(14.34)	(13.55)	(15.25)	(13.87)	(15.56)				
	1FK7060-5	141	SP140S-MF2	130	40	11	165	305	82	30	12	350	393	373	416	381	424				
		(5.56)		(5.12)	(1.58)	(0.43)	(6.50)	(12.02)	(3.23)	(1.18)	(0.47)	(13.79)	(15.48)	(14.70)	(16.39)	(15.01)	(16.71)				
	1FK7063-5	141	SP140S-MF2	130	40	11	165	305	82	30	12	395	438	418	461	426	469				
	(5.56)		(5.12)	(1.58)	(0.43)	(6.50)	(12.02)	(3.23)	(1.18)	(0.47)	(15.56)	(17.26)	(16.47)	(18.16)	(16.78)	(18.48)					
	1FK7063-5	182	SP180S-MF2	160	55	13.5	215	346	82	30	15	436	479	459	502	467	510				
	(7.17)		(6.30)	(2.17)	(0.53)	(8.47)	(13.63)	(3.23)	(1.18)	(0.59)	(17.18)	(18.87)	(18.08)	(19.78)	(18.40)	(20.09)					

1FK702.-5
1FK703.-5
1FK704.-5
1FK706.-5

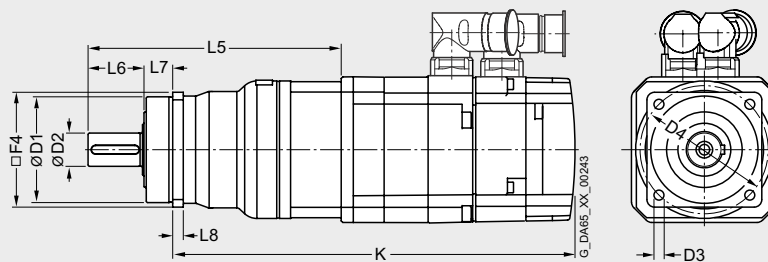

Synchronous motors

Dimension drawings

1FK7 Compact motors without/with DRIVE-CLiQ with SP+ planetary gearbox, two-stage

For motor		Dimensions in mm (in)											Encoder system:					
Shaft height	Type	F4	Planetary gearbox Type	D1	D2	D3	D4	L5	L6	L7	L8	Resolver		Incremental encoder sin/cos 1 V _{pp} Incremental encoder 22 bit (2048 S/R) Absolute encoder EnDat 32 S/R Absolute encoder 16 bit (32 S/R)		Absolute encoder EnDat 2048 S/R Absolute encoder 22 bit (2048 S/R)		
												Without brake K	With brake K	Without brake K	With brake K	Without brake K	With brake K	
1FK7 Compact with SP+ planetary gearbox, two-stage, type IM B5, natural cooling, with connector, without/with brake																		
80	1FK7080-5	141	SP140S-MF2	130	40	11	165	332	82	30	12	376	404	399	426	407	435	
		(5.56)		(5.12)	(1.58)	(0.43)	(6.50)	(13.08)	(3.23)	(1.18)	(0.47)	(14.81)	(15.92)	(15.72)	(16.78)	(16.04)	(17.14)	
	1FK7080-5	182	SP180S-MF2	160	55	13.5	215	355	82	30	15	399	427	422	449	430	458	
		(7.17)		(6.30)	(2.17)	(0.53)	(8.47)	(13.99)	(3.23)	(1.18)	(0.59)	(15.72)	(16.82)	(16.63)	(17.69)	(16.94)	(18.05)	
	1FK7080-5	212	SP210-MF2	180	75	17	250	397	105	38	17	410	438	433	460	441	469	
		(8.35)		(7.09)	(2.96)	(0.67)	(9.85)	(15.64)	(4.14)	(1.50)	(0.67)	(16.15)	(17.26)	(17.06)	(18.12)	(17.38)	(18.48)	
	1FK7083-5	141	SP140S-MF2	130	40	11	165	332	82	30	12	414	465	437	488	445	496	
		(5.56)		(5.12)	(1.58)	(0.43)	(6.50)	(13.08)	(3.23)	(1.18)	(0.47)	(16.31)	(18.32)	(17.22)	(19.23)	(17.53)	(19.54)	
		182	SP180S-MF2	160	55	13.5	215	355	82	30	15	437	488	460	511	468	519	
1FK7083-5	(7.17)		(6.30)	(2.17)	(0.53)	(8.47)	(13.99)	(3.23)	(1.18)	(0.59)	(17.22)	(19.23)	(18.12)	(20.13)	(18.44)	(20.45)		
	212	SP210-MF2	180	75	17	250	397	105	38	17	448	499	471	522	479	530		
	(8.35)		(7.09)	(2.96)	(0.67)	(9.85)	(15.64)	(4.14)	(1.50)	(0.67)	(17.65)	(19.66)	(18.56)	(20.57)	(18.87)	(20.88)		
100	1FK7100-5	182	SP180S-MF2	160	55	13.5	215	310	82	30	15	383	402	406	425	414	433	
		(7.17)		(6.30)	(2.17)	(0.53)	(8.47)	(12.21)	(3.23)	(1.18)	(0.59)	(15.09)	(15.84)	(16.00)	(16.75)	(16.31)	(17.06)	
	1FK7100-5	212	SP210-MF2	180	75	17	250	397	105	38	17	439	458	462	481	470	489	
		(8.35)		(7.09)	(2.96)	(0.67)	(9.85)	(15.64)	(4.14)	(1.50)	(0.67)	(17.30)	(18.05)	(18.20)	(18.95)	(18.52)	(19.27)	
	1FK7101-5	182	SP180S-MF2	160	55	13.5	215	310	82	30	15	409	438	432	461	440	469	
		(7.17)		(6.30)	(2.17)	(0.53)	(8.47)	(12.21)	(3.23)	(1.18)	(0.59)	(16.11)	(17.26)	(17.02)	(18.16)	(17.34)	(18.48)	
	1FK7101-5	212	SP210-MF2	180	75	17	250	397	105	38	17	465	494	488	517	496	525	
		(8.35)		(7.09)	(2.96)	(0.67)	(9.85)	(15.64)	(4.14)	(1.50)	(0.67)	(18.32)	(19.46)	(19.23)	(20.37)	(19.54)	(20.69)	
	1FK7101-5	242	SP240-MF2	200	85	17	290	454	130	40	20	495	524	518	547	526	555	
(9.53)			(7.88)	(3.35)	(0.67)	(11.43)	(17.89)	(5.12)	(1.58)	(0.79)	(19.50)	(20.65)	(20.41)	(21.55)	(20.72)	(21.87)		
1FK7103-5	182	SP180S-MF2	160	55	13.5	215	310	82	30	15	435	464	458	487	466	495		
	(7.17)		(6.30)	(2.17)	(0.53)	(8.47)	(12.21)	(3.23)	(1.18)	(0.59)	(17.14)	(18.28)	(18.05)	(19.19)	(18.36)	(19.50)		
	212	SP210-MF2	180	75	17	250	397	105	38	17	491	520	514	543	522	551		
1FK7103-5	(8.35)		(7.09)	(2.96)	(0.67)	(9.85)	(15.64)	(4.14)	(1.50)	(0.67)	(19.35)	(20.49)	(20.25)	(21.39)	(20.57)	(21.71)		
	242	SP240-MF2	200	85	17	290	454	130	40	20	521	550	544	573	552	581		
	(9.53)		(7.88)	(3.35)	(0.67)	(11.43)	(17.89)	(5.12)	(1.58)	(0.79)	(20.53)	(21.67)	(21.43)	(22.58)	(21.75)	(22.89)		
1FK7105-5	212	SP210-MF2	180	75	17	250	397	105	38	17	543	572	566	595	574	603		
	(8.35)		(7.09)	(2.96)	(0.67)	(9.85)	(15.64)	(4.14)	(1.50)	(0.67)	(21.39)	(22.54)	(22.30)	(23.44)	(22.62)	(23.76)		
1FK7105-5	242	SP240-MF2	200	85	17	290	454	130	40	20	573	602	596	625	604	633		
	(9.53)		(7.88)	(3.35)	(0.67)	(11.43)	(17.89)	(5.12)	(1.58)	(0.79)	(22.58)	(23.72)	(23.48)	(24.63)	(23.80)	(24.94)		

1FK708.-5
1FK710.-5

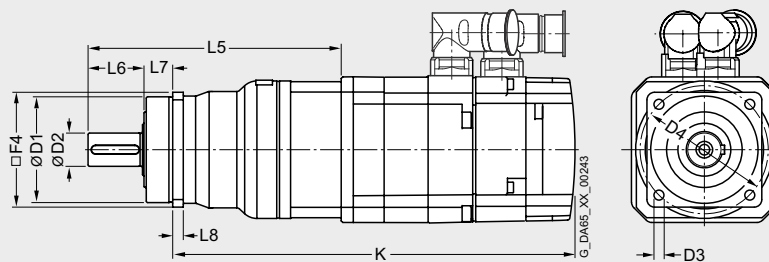

Synchronous motors Dimension drawings

1FK7 High Dynamic motors without/with DRIVE-CLiQ with SP+ planetary gearbox, two-stage

For motor		Dimensions in mm (in)											Encoder system:								
Shaft height	Type	F4	Planetary gearbox Type	D1	D2	D3	D4	L5	L6	L7	L8	Without brake		With brake		Without brake		With brake			
												K	K	K	K	K	K				
1FK7 High Dynamic with SP+ planetary gearbox, two-stage, type IM B5, natural cooling, with connector, without/with brake																					
36	1FK7033-7	62	SP060S-MF2	60	16	5.5	68	164	28	20	6	285	310	310	335	310	335	Resolver	Incremental encoder	Absolute encoder	
		(2.44)		(2.36)	(0.63)	(0.22)	(2.68)	(6.46)	(1.10)	(0.79)	(0.24)	(11.23)	(12.21)	(12.21)	(13.20)	(12.21)	(13.20)	Absolute encoder EnDat 16 S/R	sin/cos 1 V _{pp}	Absolute encoder 22 bit (2048 S/R)	
		1FK7033-7	76	SP075S-MF2	70	22	6.6	85	179	36	20	7	292	317	317	342	317	342	Absolute encoder 22 bit (2048 S/R)	Incremental encoder 22 bit (2048 S/R)	Absolute encoder EnDat 512 S/R
48	1FK7043-7	76	SP075S-MF2	70	22	6.6	85	192	36	20	7	327	356	348	377	356	385	Absolute encoder EnDat 32 S/R	Absolute encoder 16 bit (32 S/R)	Absolute encoder 20 bit (512 S/R)	
		(2.99)		(2.76)	(0.87)	(0.26)	(3.35)	(7.56)	(1.42)	(0.79)	(0.28)	(12.88)	(14.03)	(13.71)	(14.85)	(14.03)	(15.17)				
		1FK7043-7	101	SP100S-MF2	90	32	9	120	234	58	30	10	337	366	358	387	366	395			
			(3.98)		(3.55)	(1.26)	(0.35)	(4.73)	(9.22)	(2.29)	(1.18)	(0.39)	(13.28)	(14.42)	(14.11)	(15.25)	(14.42)	(15.56)			
		1FK7043-7	141	SP140S-MF2	130	40	11	165	298	82	30	12	377	406	398	427	406	435			
			(5.56)		(5.12)	(1.58)	(0.43)	(6.50)	(11.74)	(3.23)	(1.18)	(0.47)	(14.85)	(16.00)	(15.68)	(16.82)	(16.00)	(17.14)			
63	1FK7044-7	101	SP100S-MF2	90	32	9	120	234	58	30	10	362	391	383	412	391	420				
		(3.98)		(3.55)	(1.26)	(0.35)	(4.73)	(9.22)	(2.29)	(1.18)	(0.39)	(14.26)	(15.41)	(15.09)	(16.23)	(15.41)	(16.55)				
		1FK7044-7	141	SP140S-MF2	130	40	11	165	298	82	30	12	402	431	432	452	431	460			
			(5.56)		(5.12)	(1.58)	(0.43)	(6.50)	(11.74)	(3.23)	(1.18)	(0.47)	(15.84)	(16.98)	(17.02)	(17.81)	(16.98)	(18.12)			
		1FK7061-7	101	SP100S-MF2	90	32	9	120	252	58	30	10	349	392	372	415	381	424			
80		(3.98)		(3.55)	(1.26)	(0.35)	(4.73)	(9.93)	(2.29)	(1.18)	(0.39)	(13.75)	(15.44)	(14.66)	(16.35)	(15.01)	(16.71)				
		1FK7061-7	141	SP140S-MF2	130	40	11	165	305	82	30	12	378	421	401	444	410	453			
			(5.56)		(5.12)	(1.58)	(0.43)	(6.50)	(12.02)	(3.23)	(1.18)	(0.47)	(14.89)	(16.59)	(15.80)	(17.49)	(16.15)	(17.85)			
		1FK7064-7											442	485	465	508	474	517			
												(17.41)	(19.11)	(18.32)	(20.02)	(18.68)	(20.37)				
80	1FK7085-7	182	SP180S-MF2	160	55	13.5	215	355	82	30	15	504	547	526	569	535	577				
		(7.17)		(6.30)	(2.17)	(0.53)	(8.47)	(13.99)	(3.23)	(1.18)	(0.59)	(19.84)	(21.54)	(20.71)	(22.40)	(21.06)	(22.72)				
		1FK7085-7	212	SP210-MF2	180	75	17	250	397	105	38	17	515	557	537	580	546	588			
			(8.35)		(7.09)	(2.96)	(0.67)	(9.85)	(15.64)	(4.14)	(1.50)	(0.67)	(20.29)	(21.95)	(21.16)	(22.85)	(21.51)	(23.17)			
80	1FK7086-7	182	SP180S-MF2	160	55	13.5	215	355	82	30	15	504	547	526	569	535	577				
		(7.17)		(6.30)	(2.17)	(0.53)	(8.47)	(13.99)	(3.23)	(1.18)	(0.59)	(19.84)	(21.54)	(20.71)	(22.40)	(21.06)	(22.72)				
	1FK7086-7	212	SP210-MF2	180	75	17	250	397	105	38	17	515	557	537	580	546	588				
		(8.35)		(7.09)	(2.96)	(0.67)	(9.85)	(15.64)	(4.14)	(1.50)	(0.67)	(20.29)	(21.95)	(21.16)	(22.85)	(21.51)	(23.17)				

1FK703.-7
1FK704.-7
1FK706.-7
1FK708.-7

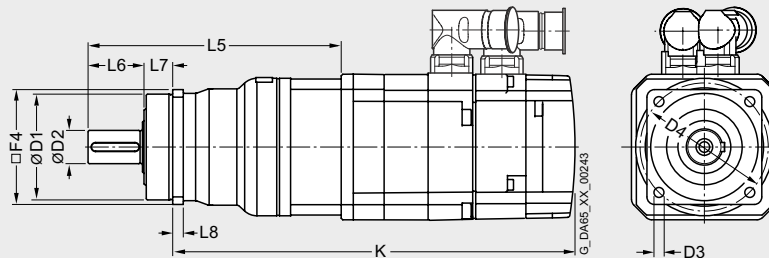

Synchronous motors

Dimension drawings

1FK7 Compact motors without/with DRIVE-CLiQ with LP+ planetary gearbox, single-stage

For motor		Dimensions in mm (in)																
Shaft height	Type	DIN IEC	Encoder system:				Incremental encoder sin/cos 1 V _{pp}				Absolute encoder EnDat 2048 S/R				l	d	a ₁	
			Resolver		Absolute encoder EnDat 16 S/R		Absolute encoder EnDat 32 S/R		Absolute encoder 16 bit (32 S/R)		Absolute encoder EnDat 22 bit (2048 S/R)		Absolute encoder EnDat 512 S/R					Absolute encoder 20 bit (512 S/R)
		Without brake		With brake		Without brake		With brake		Without brake		With brake						
		k	K	k	K	k	K	k	K	k	K	k	K	k	K	E	D	P
		LB	-	LB	-	LB	-	LB	-	LB	-	LB	-	LB	-			
1FK7 Compact with LP+ planetary gearbox, single-stage, type IM B5, natural cooling, with connector, without/with brake																		
28	1FK7022-5	153 (6.02)	216 (8.50)	175 (6.89)	238 (9.37)	178 (7.01)	241 (9.49)	200 (7.87)	263 (10.35)	178 (7.01)	241 (9.49)	200 (7.87)	263 (10.35)	20 (0.79)	9 (0.35)			
	1FK7022-5				236 (9.29)		258 (10.16)		261 (10.28)		283 (11.14)		261 (10.28)		283 (11.14)			
36	1FK7032-5	150 (5.91)	240 (9.45)	175 (6.89)	265 (10.43)	175 (6.89)	265 (10.43)	200 (7.87)	290 (11.42)	175 (6.89)	265 (10.43)	200 (7.87)	290 (11.42)	30 (1.18)	14 (0.55)	92 (3.62)		
	1FK7034-5				175 (6.89)	265 (10.43)	200 (7.87)	290 (11.42)	200 (7.87)	225 (8.86)	315 (12.40)	200 (7.87)	290 (11.42)	225 (8.86)	315 (12.40)			
48	1FK7040-5	135 (5.31)	247 (9.72)	164 (6.46)	276 (10.87)	155 (6.10)	267 (10.51)	184 (7.24)	296 (11.65)	164 (6.46)	276 (10.87)	193 (7.60)	305 (12.01)	40 (1.57)	19 (0.75)	120 (4.72)		
	1FK7042-5				162 (6.38)	274 (10.79)	191 (7.52)	303 (11.93)	183 (7.20)	295 (11.61)	212 (8.35)	324 (12.76)	191 (7.52)	303 (11.93)	220 (8.66)	332 (13.07)		
63	1FK7060-5	157 (6.18)	297 (11.69)	200 (7.87)	340 (13.39)	180 (7.09)	320 (12.60)	223 (8.78)	363 (14.29)	188 (7.40)	328 (12.91)	231 (9.09)	371 (14.61)	50 (1.97)	24 (0.94)	155 (6.10)		
	1FK7063-5				202 (7.95)	342 (13.46)	245 (9.65)	385 (15.16)	225 (8.86)	365 (14.37)	268 (10.55)	408 (16.06)	233 (9.17)	373 (14.69)	276 (10.87)	416 (16.38)		
80	1FK7080-5	156 (6.14)	325 (12.80)	184 (7.24)	353 (13.90)	179 (7.05)	347 (13.66)	206 (8.11)	375 (14.76)	187 (7.36)	355 (13.98)	215 (8.46)	384 (15.12)	58 (2.28)	32 (1.26)	186 (7.32)		
	1FK7083-5				194 (7.64)	363 (14.29)	245 (9.65)	414 (16.30)	217 (8.54)	385 (15.16)	268 (10.55)	436 (17.17)	225 (8.86)	393 (15.47)	276 (10.87)	444 (17.48)		

Shaft height	Type	Planetary gearbox Type	D ₁	D ₂	D ₃	D ₄	D ₅	L ₂	L ₃	L ₄	L ₅	L ₈	L ₉	L ₁₀	L ₁₆
			-	-	-	-	-	-	-	-	-	-	-	-	-
28	1FK7022-5	LP050-M01	50 (1.97)	35 (1.38)	12 (0.47)	44 (1.73)	M4	18 (0.71)	4 (0.16)	7 (0.28)	8 (0.31)	14 (0.55)	4 (0.16)	50 (1.97)	88 (3.46)
	1FK7022-5	LP070-M01	70 (2.76)	52 (2.05)	16 (0.63)	62 (2.44)	M5	28 (1.10)	5 (0.20)	8 (0.31)	10 (0.39)	18 (0.71)	5 (0.20)	70 (2.76)	119 (4.69)
36	1FK7032-5	LP070-M01	70 (2.76)	52 (2.05)	16 (0.63)	62 (2.44)	M5	28 (1.10)	5 (0.20)	8 (0.31)	10 (0.39)	18 (0.71)	5 (0.20)	70 (2.76)	126 (4.96)
	1FK7034-5														
48	1FK7040-5	LP090-M01	90 (3.54)	68 (2.68)	22 (0.87)	80 (3.15)	M6	36 (1.42)	5 (0.20)	10 (0.39)	12 (0.47)	25 (0.98)	6 (0.24)	90 (3.54)	158 (6.22)
	1FK7042-5														
63	1FK7060-5	LP120-M01	120 (4.72)	90 (3.54)	32 (1.26)	108 (4.25)	M8	58 (2.28)	6 (0.24)	12 (0.47)	16 (0.63)	35 (1.38)	10 (0.39)	120 (4.72)	210 (8.27)
	1FK7063-5														
80	1FK7080-5	LP155-M01	155 (6.10)	120 (4.72)	40 (1.57)	140 (5.51)	M10	82 (3.23)	8 (0.31)	15 (0.59)	20 (0.79)	43 (1.69)	12 (0.47)	150 (5.91)	266 (10.47)
	1FK7083-5														

1FK702.-5
1FK703.-5
1FK704.-5
1FK706.-5
1FK708.-5

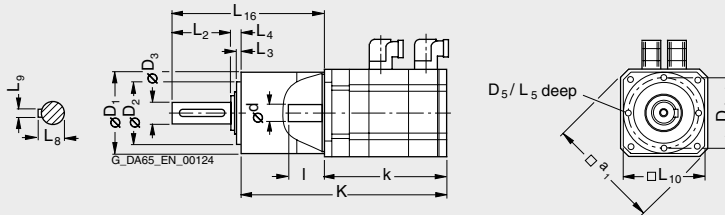

Synchronous motors Dimension drawings

1FK7 Compact motors without/with DRIVE-CLiQ with LP+ planetary gearbox, single-stage

For motor		Dimensions in mm (in)																	
Shaft height	Type	DIN IEC	Encoder system: Resolver												l E	d D	a ₁ P		
			Without brake		With brake		Without brake		With brake		Without brake		With brake						
			k	K	k	K	k	K	k	K	k	K	k	K	k	K			
			LB	-	LB	-	LB	-	LB	-	LB	-	LB	-	LB	-			
1FK7 Compact with LP+ planetary gearbox, single-stage, type IM B5, natural cooling, with connector, without/with brake																			
100	1FK7100-5		185 (7.28)	374 (14.72)	204 (8.03)	393 (15.47)	208 (8.19)	396 (15.59)	227 (8.94)	415 (16.34)	216 (8.50)	404 (15.91)	235 (9.25)	423 (16.65)	80 (3.15)	38 (1.50)	240 (9.45)		
	1FK7101-5		211 (8.31)	400 (15.75)	240 (9.45)	429 (16.89)	234 (9.21)	422 (16.61)	263 (10.35)	452 (17.80)	242 (9.53)	430 (16.93)	271 (10.67)	460 (18.11)					
	1FK7103-5		237 (9.33)	426 (16.77)	266 (10.47)	455 (17.91)	260 (10.24)	448 (17.64)	289 (11.38)	478 (18.82)	268 (10.55)	456 (17.95)	297 (11.69)	486 (19.13)					
	1FK7105-5		289 (11.38)	478 (18.82)	318 (12.52)	507 (19.96)	312 (12.28)	500 (19.69)	341 (13.43)	530 (20.87)	320 (12.60)	508 (20.00)	349 (13.74)	538 (21.18)					

Shaft height	Type	Planetary gearbox Type	Planetary gearbox													
			D ₁	D ₂	D ₃	D ₄	D ₅	L ₂	L ₃	L ₄	L ₅	L ₈	L ₉	L ₁₀	L ₁₆	
100	1FK710-5	LP155-M01	155 (6.10)	120 (4.72)	40 (1.57)	140 (5.51)	M10	82 (3.23)	8 (0.31)	15 (0.59)	20 (0.79)	43 (1.69)	12 (0.47)	150 (5.91)	286 (11.26)	

1FK710-5

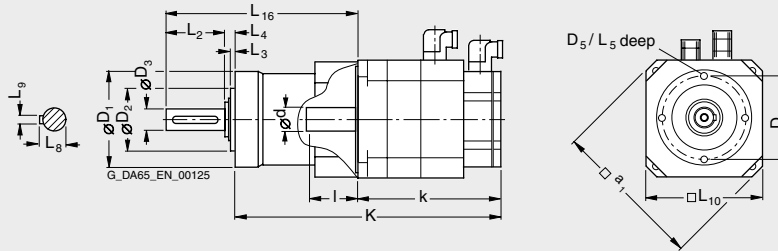

Synchronous motors

Dimension drawings

1FK7 High Dynamic motors without/with DRIVE-CLiQ with LP+ planetary gearbox, single-stage

For motor		Dimensions in mm (in)															
Shaft height	Type	DIN IEC	Encoder system:				Without brake				With brake				I E	d D	a ₁ P
			Resolver	Absolute encoder EnDat 16 S/R	Absolute encoder 15 bit (16 S/R)	Incremental encoder sin/cos 1 V _{pp}	Absolute encoder 22 bit (2048 S/R)	Absolute encoder EnDat 32 S/R	Absolute encoder 16 bit (32 S/R)	Without brake	With brake	Without brake	With brake	Without brake			
			k LB	K -	k LB	K -	k LB	K -	k LB	K -	k LB	K -	k LB	K -			
1FK7 High Dynamic with LP+ planetary gearbox, single-stage, type IM B5, natural cooling, with connector, without/with brake																	
36	1FK7033-7		170 (6.69)	260 (10.24)	195 (7.68)	285 (11.22)	195 (7.68)	285 (11.22)	220 (8.66)	310 (12.20)	195 (7.68)	285 (11.22)	220 (8.66)	310 (12.20)	30 (1.18)	14 (0.55)	92 (3.62)
48	1FK7043-7		191 (7.52)	303 (11.93)	220 (8.66)	332 (13.07)	212 (8.35)	324 (12.76)	240 (9.45)	352 (13.86)	220 (8.66)	332 (13.07)	249 (9.80)	361 (14.21)	40 (1.57)	19 (0.75)	120 (4.72)
	1FK7044-7		216 (8.50)	328 (12.91)	245 (9.65)	357 (14.06)	237 (9.33)	349 (13.74)	265 (10.43)	377 (14.84)	245 (9.65)	357 (14.06)	274 (10.79)	386 (15.20)			
63	1FK7061-7		185 (7.28)	325 (12.80)	228 (8.98)	368 (14.49)	208 (8.19)	348 (13.70)	251 (9.88)	391 (15.39)	217 (8.54)	357 (14.06)	260 (10.24)	400 (15.75)	50 (1.97)	24 (0.94)	155 (6.10)
	1FK7064-7		249 (9.80)	389 (15.31)	292 (11.50)	432 (17.01)	272 (10.71)	412 (16.22)	315 (12.40)	455 (17.91)	281 (11.06)	421 (16.57)	324 (12.76)	464 (18.27)			
80	1FK7085-7		261 (10.28)	430 (16.93)	304 (11.97)	473 (18.62)	284 (11.18)	453 (17.83)	326 (12.83)	495 (19.49)	292 (11.50)	461 (18.15)	335 (13.19)	504 (19.84)	58 (2.28)	32 (1.26)	186 (7.32)
	1FK7086-7																

Shaft height	Type	Planetary gearbox Type	Dimensions in mm (in)													
			D ₁	D ₂	D ₃	D ₄	D ₅	L ₂	L ₃	L ₄	L ₅	L ₈	L ₉	L ₁₀	L ₁₆	
36	1FK7033-7	LP070-M01	70 (2.76)	52 (2.05)	16 (0.63)	62 (2.44)	M5	28 (1.10)	5 (0.20)	8 (0.31)	10 (0.39)	18 (0.71)	5 (0.20)	70 (2.76)	126 (4.96)	
48	1FK7043-7	LP090-M01	90 (3.54)	68 (2.68)	22 (0.87)	80 (3.15)	M6	36 (1.42)	5 (0.20)	10 (0.39)	12 (0.47)	25 (0.98)	6 (0.24)	90 (3.54)	158 (6.22)	
	1FK7044-7															
63	1FK7061-7	LP120-M01	120 (4.72)	90 (3.54)	32 (1.26)	108 (4.25)	M8	58 (2.28)	6 (0.24)	12 (0.47)	16 (0.63)	35 (1.38)	10 (0.39)	120 (4.72)	210 (8.27)	
	1FK7064-7															
80	1FK7085-7	LP155-M01	155 (6.10)	120 (4.72)	40 (1.57)	140 (5.51)	M10	82 (3.23)	8 (0.31)	15 (0.59)	20 (0.79)	43 (1.69)	12 (0.47)	150 (5.91)	266 (10.47)	
	1FK7086-7															

1FK7033-7
1FK704-7
1FK706-7
1FK708-7

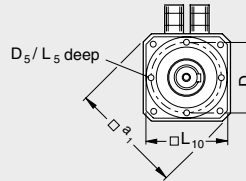
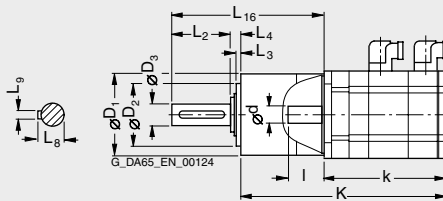

Synchronous motors Dimension drawings

1FK7-DYA motors without/with DRIVE-CLiQ with planetary gearbox, single-stage

For motor		Dimensions in mm (in)															
		Encoder system:				Resolver				Absolute encoder EnDat 16 S/R				Absolute encoder 15 bit (16 S/R)			
		Incremental encoder sin/cos 1 V _{pp}				Incremental encoder 22 bit (2048 S/R)				Absolute encoder EnDat 32 S/R				Absolute encoder 20 bit (32 S/R)			
		Without brake				With brake				Without brake				With brake			
Shaft height	Type	K	K1	K	K1	K	K1	K	K1	K	K1	K	K1	K	K1	K	K1
1FK7-DYA with planetary gearbox, single-stage, type IM B5, natural cooling, with connector, without/with brake																	
36	1FK7032-5	197 (7.76)	177 (6.97)	222 (8.74)	202 (7.95)	222 (8.74)	202 (7.95)	247 (9.72)	227 (8.94)	222 (8.74)	202 (7.95)	247 (9.72)	227 (8.94)	222 (8.74)	202 (7.95)	247 (9.72)	227 (8.94)
	1FK7034-5	222 (8.74)	202 (7.95)	247 (9.72)	227 (8.94)	227 (8.74)	202 (7.95)	247 (9.72)	272 (10.71)	252 (9.92)	247 (9.72)	227 (8.94)	272 (10.71)	252 (9.92)	247 (9.72)	227 (8.94)	272 (10.71)
48	1FK7040-5	194 (7.64)	174 (6.85)	223 (8.78)	203 (7.99)	214 (8.43)	194 (7.64)	243 (9.57)	223 (8.78)	223 (8.78)	203 (7.99)	252 (9.92)	232 (9.13)	223 (8.78)	203 (7.99)	252 (9.92)	232 (9.13)
	1FK7042-5	221 (8.70)	201 (7.91)	250 (9.84)	230 (9.06)	242 (9.53)	222 (8.74)	271 (10.67)	251 (9.88)	250 (9.84)	230 (9.06)	279 (10.98)	259 (10.20)	250 (9.84)	230 (9.06)	279 (10.98)	259 (10.20)
63	1FK7060-5	233 (9.17)	208 (8.19)	261 (10.28)	236 (9.29)	256 (10.08)	231 (9.09)	284 (11.18)	259 (10.20)	264 (10.39)	239 (9.41)	292 (11.50)	267 (10.51)	264 (10.39)	239 (9.41)	292 (11.50)	267 (10.51)
	1FK7063-5	278 (10.94)	253 (9.96)	306 (12.05)	281 (11.06)	301 (11.85)	276 (10.87)	329 (12.95)	304 (11.97)	309 (12.17)	284 (11.18)	337 (13.27)	312 (12.28)	309 (12.17)	284 (11.18)	337 (13.27)	312 (12.28)
80	1FK7080-5	250 (9.84)	220 (8.66)	278 (10.94)	248 (9.76)	273 (10.75)	243 (9.57)	300 (11.81)	270 (10.63)	281 (11.06)	251 (9.88)	309 (12.17)	279 (10.98)	281 (11.06)	251 (9.88)	309 (12.17)	279 (10.98)
	1FK7083-5	288 (11.34)	258 (10.16)	339 (13.35)	309 (12.17)	311 (12.24)	281 (11.06)	362 (14.25)	332 (13.07)	319 (12.56)	289 (11.38)	370 (14.57)	340 (13.39)	319 (12.56)	289 (11.38)	370 (14.57)	340 (13.39)

		Planetary gearbox																
Shaft height	Type	Type	D1	D2	D3	D4	D5	D7	D8	L1	L2	L3	L4	L5	L8	L9	L10	L12
36	1FK7032-5	DYA70-10	70 (2.76)	52 (2.05)	16 (0.63)	62 (2.44)	M5	82 (3.23)	5.5 (0.22)	56 (2.20)	28 (1.10)	5 (0.20)	8 (0.31)	10 (0.39)	18 (0.71)	5 (0.20)	20 (0.79)	76 (2.99)
	1FK7034-5	DYA70-5																
48	1FK7040-5	DYA90-10	90 (3.54)	68 (2.68)	22 (0.87)	80 (3.15)	M6	105 (4.13)	7 (0.28)	66 (2.60)	36 (1.42)	5 (0.20)	10 (0.39)	12 (0.47)	24.5 (0.96)	6 (0.24)	20 (0.79)	101 (3.98)
	1FK7042-5	DYA90-5																
63	1FK7060-5	DYA120-10	120 (4.72)	90 (3.54)	32 (1.26)	108 (4.25)	M8	140 (5.51)	9 (0.35)	95 (3.74)	58 (2.28)	6 (0.24)	12 (0.47)	16 (0.63)	35 (1.38)	10 (0.39)	25 (0.98)	128 (5.04)
	1FK7063-5	DYA120-5																
80	1FK7080-5	DYA155-10	155 (6.10)	120 (4.72)	40 (1.57)	140 (5.51)	M10	170 (6.69)	11 (0.43)	127 (5.00)	82 (3.23)	8 (0.31)	15 (0.59)	20 (0.79)	43 (1.69)	12 (0.47)	30 (1.18)	161 (6.34)
	1FK7083-5	DYA155-5																

1FK703.-5
1FK704.-5
1FK706.-5
1FK708.-5

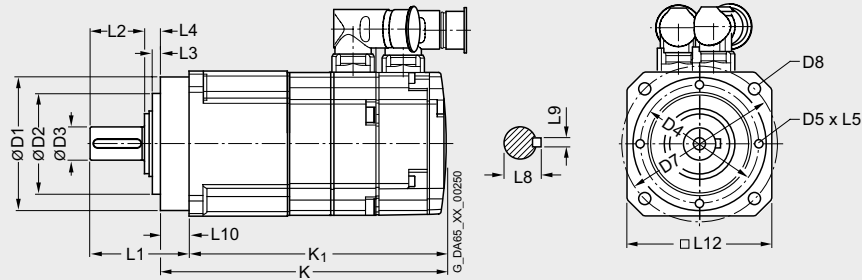

Synchronous motors

Dimension drawings

1FN3 linear motors Version for peak load – water cooling

Primary section	Dimensions in mm (in)					Secondary section	Dimensions in mm (in)				
	Without precision cooling		With precision cooling		Primary section length L_P		Without precision cooling		With precision cooling and cover		Secondary-section length L_S
Type	b_M	h_M	b_M	h_M			Type	b_S	h_S	b_S	
1FN3, version for peak load – water cooling											
1FN3050-2W	67 (2.64)	48.5 (1.91)	76 (2.99)	63.4 (2.50)	255 (10.04)	1FN3050-4SA00-0AA0	58 (2.28)	11.8 (0.46)	75 (2.95)	14.8 (0.58)	120 (4.72)
1FN3100-1W	96 (3.78)	48.5 (1.91)	–	–	150 (5.91)	1FN3100-4SA00-0AA0	88 (3.46)	11.8 (0.46)	105 (4.13)	14.8 (0.58)	120 (4.72)
1FN3100-2W			105 (4.13)	63.4 (2.50)	255 (10.04)						
1FN3100-3W					360 (14.17)						
1FN3100-4W					465 (18.31)						
1FN3100-5W					570 (22.44)						
1FN3150-1W	126 (4.96)	50.5 (1.99)	–	–	150 (5.91)	1FN3150-4SA00-0AA0	118 (4.65)	13.8 (0.54)	135 (5.31)	16.8 (0.66)	120 (4.72)
1FN3150-2W			135 (5.31)	65.4 (2.57)	255 (10.04)						
1FN3150-3W					360 (14.17)						
1FN3150-4W					465 (18.31)						
1FN3150-5W					570 (22.44)						
1FN3300-1W	141 (5.55)	64.1 (2.52)	–	–	221 (8.70)	1FN3300-4SA00-0AA0	134 (5.28)	16.5 (0.65)	151 (5.94)	19.5 (0.77)	184 (7.24)
1FN3300-2W			151 (5.94)	79 (3.11)	382 (15.04)						
1FN3300-3W					543 (21.38)						
1FN3300-4W					704 (27.72)						
1FN3450-2W	188 (7.40)	66.1 (2.60)	197 (7.76)	81 (3.19)	382 (15.04)						
1FN3450-3W					543 (21.38)						
1FN3450-4W					704 (27.72)						
1FN3600-2W	248 (9.76)	64.1 (2.52)	257 (10.12)	86 (3.39)	382 (15.04)	1FN3600-4SA00-0AA0	240 (9.45)	16.5 (0.65)	247 (9.72)	26.5 (1.04)	184 (7.24)
1FN3600-3W					543 (21.38)						
1FN3600-4W					704 (27.72)						
1FN3900-2W	342 (13.46)	66.1 (2.60)	351 (13.82)	88 (3.46)	382 (15.04)	1FN3900-4SA00-0AA0	334 (13.15)	18.5 (0.73)	341 (13.43)	28.5 (1.12)	184 (7.24)
1FN3900-3W					543 (21.38)						
1FN3900-4W					704 (27.72)						

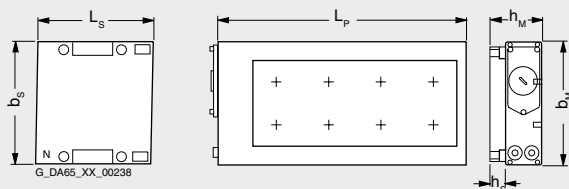

1FN3050 to 1FN3450 without precision cooling

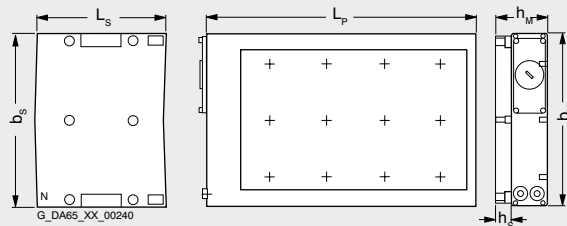

1FN3600 to 1FN3900 without precision cooling
Note: 4-row drill pattern with 1FN3900 for fixing the primary section

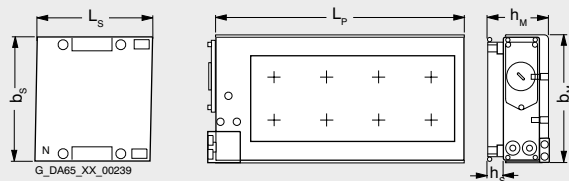

1FN3050 to 1FN3450 with precision cooling

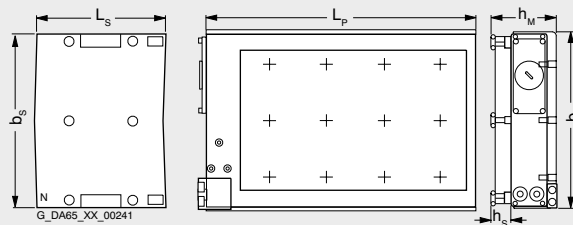

1FN3600 to 1FN3900 with precision cooling
Note: 4-row drill pattern with 1FN3900 for fixing the primary section

Synchronous motors

Dimension drawings

1FN3 linear motors

Version for continuous load – water cooling

Primary section	Dimensions in mm (in)				Primary section length	Secondary section	Dimensions in mm (in)				Secondary section length
	Without precision cooling		With precision cooling				Without precision cooling		With precision cooling		
Type	b_M	h_M	b_M	h_M	L_P	Type	b_S	h_S	b_M	h_M	L_S
1FN3, version for continuous load – water cooling											
1FN3050-1ND	67 (2.64)	59.4 (2.34)	76 (2.99)	74.3 (2.93)	162 (6.38)	1FN3050-4SA00-0AA0	58 (2.28)	11.8 (0.46)	75 (2.95)	14.8 (0.58)	120 (4.72)
1FN3050-2NB					267 (10.51)						
1FN3100-1NC	96 (3.78)	59.4 (2.34)	105 (4.13)	74.3 (2.93)	162 (6.38)	1FN3100-4SA00-0AA0	88 (3.46)	11.8 (0.46)	105 (4.13)	14.8 (0.58)	120 (4.72)
1FN3100-2NC					267 (10.51)						
1FN3100-3NC					372 (14.65)						
1FN3100-4NC					477 (18.78)						
1FN3150-1NC	126 (4.96)	61.4 (2.42)	135 (5.31)	76.3 (3.00)	162 (6.38)	1FN3150-4SA00-0AA0	118 (4.65)	13.8 (0.54)	135 (5.31)	16.8 (0.66)	120 (4.72)
1FN3150-2NB					267 (10.51)						
1FN3150-3NC					372 (14.65)						
1FN3150-4NB					477 (18.78)						
1FN3300-1NC	141 (5.55)	78 (3.07)	150 (5.91)	92.9 (3.66)	238 (9.37)	1FN3300-4SA00-0AA0	134 (5.28)	16.5 (0.65)	151 (5.94)	19.5 (0.77)	184 (7.24)
1FN3300-2NC					399 (15.71)						
1FN3300-3NC					560 (22.05)						
1FN3300-4NB					721 (28.39)						
1FN3450-2NC	188 (7.40)	80 (3.15)	197 (7.76)	94.9 (3.74)	399 (15.71)	1FN3450-4SA00-0AA0	180 (7.09)	18.5 (0.73)	197 (7.76)	21.5 (0.85)	184 (7.24)
1FN3450-3NC					560 (22.05)						
1FN3450-4NB					721 (28.39)						
1FN3600-2NB	248 (9.76)	78 (3.07)	257 (10.12)	99.9 (3.93)	399 (15.71)	1FN3600-4SA00-0AA0	240 (9.45)	16.5 (0.65)	247 (9.72)	26.5 (1.04)	184 (7.24)
1FN3600-3NB					560 (22.05)						
1FN3600-4NB					721 (28.39)						
1FN3900-2NB	342 (13.46)	80 (3.15)	351 (13.82)	101.9 (4.01)	399 (15.71)	1FN3900-4SA00-0AA0	334 (13.15)	18.5 (0.73)	341 (13.43)	28.5 (1.12)	184 (7.24)
1FN3900-3NB					560 (22.05)						
1FN3900-4NB					721 (28.39)						

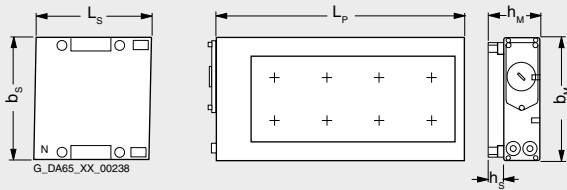

1FN3050 to 1FN3450 without precision cooling

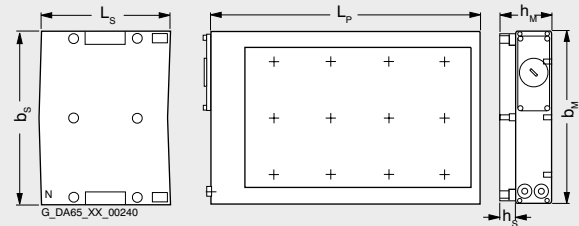

1FN3600 to 1FN3900 without precision cooling

Note: 4-row drill pattern with 1FN3900 for fixing the primary section

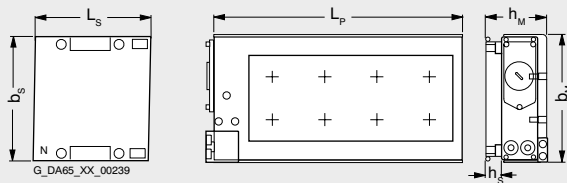

1FN3050 to 1FN3450 with precision cooling

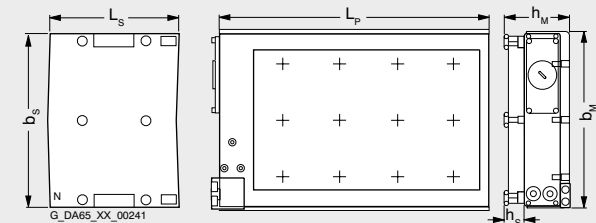

1FN3600 to 1FN3900 with precision cooling

Note: 4-row drill pattern with 1FN3900 for fixing the primary section

Synchronous motors

Dimension drawings

1FW6 built-in torque motors Water cooling

For motor	Dimensions in mm (in)				
Type	D ₁	D ₂	D ₃	L ₁	L ₂
1FW6, type IM B5, water cooling					
1FW6090-0.B05	230 (9.06)	140 (5.51)	170 (6.69)	90 (3.54)	51 (2.01)
1FW6090-0.B07				110 (4.33)	71 (2.80)
1FW6090-0.B10				140 (5.51)	101 (3.98)
1FW6090-0.B15				190 (7.48)	151 (5.94)
1FW6130-0.B05	310 (12.20)	220 (8.66)	254 (10.00)	90 (3.54)	51 (2.01)
1FW6130-0.B07				110 (4.33)	71 (2.80)
1FW6130-0.B10				140 (5.51)	101 (3.98)
1FW6130-0.B15				190 (7.48)	151 (5.94)
1FW6160-0.B05	440 (17.32)	280 (11.02)	328 (12.91)	110 (4.33)	60 (2.36)
1FW6160-0.B07				130 (5.12)	80 (3.15)
1FW6160-0.B10				160 (6.30)	110 (4.33)
1FW6160-0.B15				210 (8.27)	160 (6.30)
1FW6190-0.B05	502 (19.76)	342 (13.46)	389 (15.31)	110 (4.33)	60 (2.36)
1FW6190-0.B07				130 (5.12)	80 (3.15)
1FW6190-0.B10				160 (6.30)	110 (4.33)
1FW6190-0.B15				210 (8.27)	160 (6.30)
1FW6230-0.B05	576 (22.68)	416 (16.38)	463 (18.23)	110 (4.33)	60 (2.36)
1FW6230-0.B07				130 (5.12)	80 (3.15)
1FW6230-0.B10				160 (6.30)	110 (4.33)
1FW6230-0.B15				210 (8.27)	160 (6.30)
1FW6290-0.B15	730 (28.74)	522 (20.55)	580 (22.83)	220 (8.66)	170 (6.69)

1FW6090
1FW6130

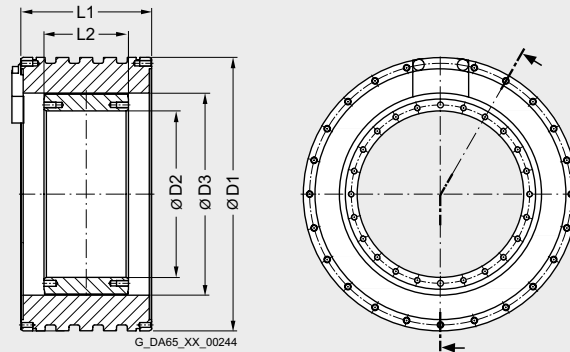

1FW6160
1FW6190
1FW6230
1FW6290

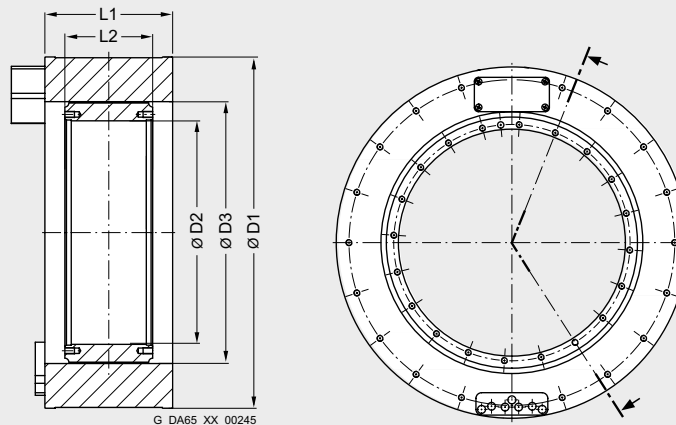

Synchronous motors

Dimension drawings

2SP1 ECS motor spindles Water cooling

For motor	Dimensions in mm (in)								
Type	D1	D2	D3	D4	D5	L1 ¹⁾	L2	L3	L4
2SP1, type IM B5, water cooling									
2SP1202	200 (7.88)	199 (7.84)	250 (9.85)	225 (8.87)	150 (5.91)	735 ⁴⁾ (28.94)	115.5 (4.55)	309 ⁴⁾ (12.17)	58 ⁴⁾ (2.28)
2SP1204						835 ⁴⁾ (32.87)			
2SP1253²⁾	250 (9.85)	237 (9.34)	310 (12.21)	275 (10.84)	150 (5.91)	813 (32.03)	124.4 (4.90)	310 (12.21)	43 (1.69)
2SP1255²⁾						913 (35.97)			
2SP1253³⁾						819 (32.27)			
2SP1255³⁾						919 (36.21)			

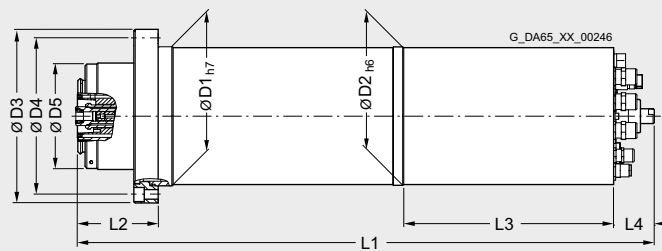
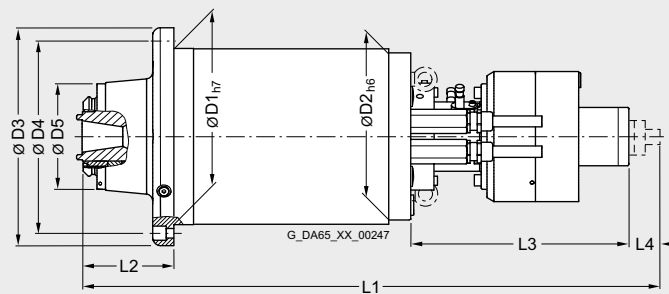
2SP120**2SP125**

1) The spindle is approx. 43 mm (1.69 in) shorter without turning bushing.

2) HSK A63 tool interface.

3) SK40, CAT40, BT40 tool interfaces.

4) Spindle length L1 is approx. 118 mm (4.65 in) shorter, L3 approx. 147 mm (5.79 in) shorter and L4 approx. 30 mm (1.18 in) longer with a hydraulic tool clamping device.

Synchronous motors

CAD CREATOR

Dimension drawing and 2D/3D CAD generator

Overview

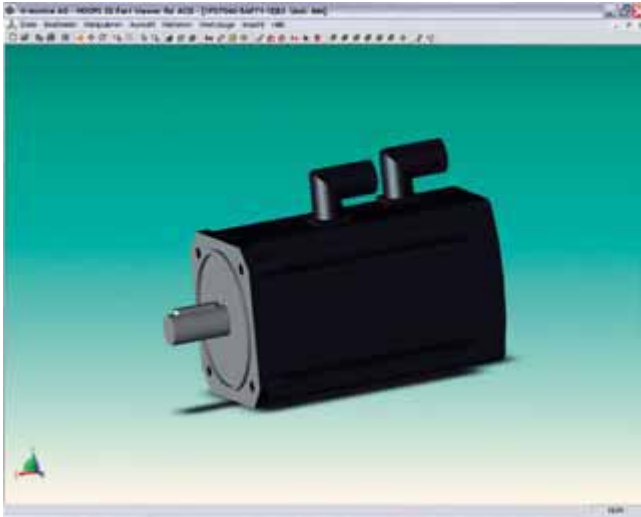

The CAD CREATOR provides a user-friendly interface which helps you to create product-specific data quickly and supports you in generating plant documentation containing project-specific information.

Benefits

- Multilingual operator interface in English, French, German, Italian and Spanish
- Dimension drawings with measurements in mm or inches
- Dimension drawings and 2D/3D CAD data for
 - 1FT6/1FT7/1FK7 synchronous motors
 - 1PH7/1PH4/1PM4/1PM6 asynchronous motors
 - 1FT6/1FK7/1FK7-DYA geared motors
 - 1FW3 torque motors
 - 1FE1 built-in motors

The CAD CREATOR provides you with various options to begin with product configuration:

- Order number
- Order number search
- Geometric data

Benefits (continued)

Once a product is successfully configured, the product-specific information, such as dimension drawings and 2D/3D CAD data are displayed and made available for storing in various formats, e.g.: *.pdf, *.dxf, *.stp or *.igs.

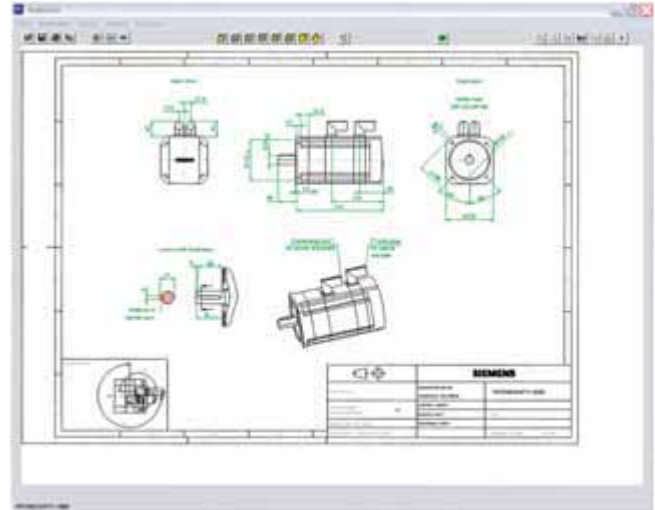

The CAD CREATOR is available on CD-ROM and as an Internet application.

Additional information is available on the Internet at:



<http://www.siemens.com/cad-creator>

