



www.ctdynamics.com



PROVISIONAL
DutymAx (DS) Motor
BROCHURE

Introducing the DutymAx motor

Years of experience of designing specialised brushless motors for Defence applications, Aerospace and Space Satellites instrumentation has been focused on the demands of the industrial controls market. Originally designed to be a vital element in Control Techniques own motion controls and servo drives, these motors are now available as a standalone component. Similarly, the feedback device, resolver, owes much to the heritage of the company and its skills in the design and manufacture of rotating components. The company is now offering to system builders worldwide, this range of components based on high quality and sophisticated design, coupled with ISO9001 quality assured manufacture.

The DutymAx servo motors have excellent power to size ratio giving optimal dynamic response. This is provided by a superior design of magnetic circuit within the motor, using high energy rare earth magnets, and a low inertia laminated rotor and a high slot fill stator.

The shaft resolver is mounted directly onto the motor offering a robust and accurate measuring system for speed and position signals to suit most drives and control system requirements.

The motors are available in four frame sizes, 75, 95, 115 and 142 mm square body.

Standard Features

- Modular rotor design.
- Rotor assembly balanced to ISO1940 (BS 6861) G 6.3.
- Class H insulation.
- High thermal dissipation.
- Thermal overload protection.
- Rear shaft extension.
- Front shaft lip-seal up to 3,000rpm.
- Connectors for Power and signal.
- High output for size and weight.
- IEC mounting flange.
- Shaft key as standard.

Optional Features

- Hybrid box and Terminal box available.
- Parking brake with no increase in length, retro-fit table at factory.
- High inertia.

Optional Products

- Cable assemblies for power, signal and brake.

Motor Specification

Physical		Environmental	
Insulation class	Class H BS EN60034-1		
Rotational accuracy	IEC60072-1 Class N	Operating Temperature	0°C to 40°C ambient
Degree of balance	Rotor is balanced to ISO 1940 or (BS6861) G 6.3	Storage Temperature	-20°C to 70°C
Shaft extension	Dimension to IEC60072 -1, key and keyway to IEC60072-1	Temperature rise	125°C over ambient of 40°C Max
Temperature monitoring	PTC thermistor, 160°C switch temperature	Relative Humidity	90% Non condensing
Connections	Separate connectors or cable input glands for motor, resolver and thermistor, brake.		

Resolver Specification

DRG No	UNITS	34489/03
TYPE No		55RSS116P
VOLTAGE	VOLTS.	6
FREQUENCY	KHz.	7.5
PRIMARY		ROTOR
No OF POLES		2
TRANSFORMATION RATIO		0.28 ± 10%
PHASE SHIFT	DEG NOM.	-1
PRIMARY CURRENT	mA NOM.	55
INPUT POWER	mW NOM.	150
ELECTRICAL ERROR	Mins MAX.	± 20
TOTAL NULL VOLTS	mV MAX.	20
Z RO	OHMS NOM.	75+j105
Z SO	OHMS NOM.	36+j68
Z SS	OHMS NOM.	31+j60
D.C RESISTANCE (EXCITATION)	OHMS.	35
D.C RESISTANCE (STATOR)	OHMS.	11
TEMPERATURE RANGE	DEG C NOM.	-55 TO +155
INERTIA	gcm ²	198
LEAD LENGTH	Mm MIN.	380
SHAFT		15.011/15.000

Brake Specification

Motor Frame	Holding Torque	Supply Volts	Input Power	Current	Moment of Inertia	Weight
Size	Nm	V d.c.	Watts	A	kgm ² x 10-6	kg
75	2	24	14	0.58	3.0	0.4
95	6	24	30	1.25	29	0.5
115	12	24	30	1.25	49	0.9
142	20	24	30	1.25	128.0	2.25

- The brakes are intended for parking duty and engage on power de-energisation.
- Refer to drive centre if your application requires dynamic braking in emergency conditions.
- To provide protection to the brake control circuit it is recommended that a diode is connected across the output terminals of the solid state or relay contacts devices. Ask for detailed information.
- Motor length is identical with or without brake.

Ordering Information

Use the information below in the illustration to create an order code for a DutymAx motor. The details in the band are an example of an order reference.

ORDER REFERENCE EXAMPLE

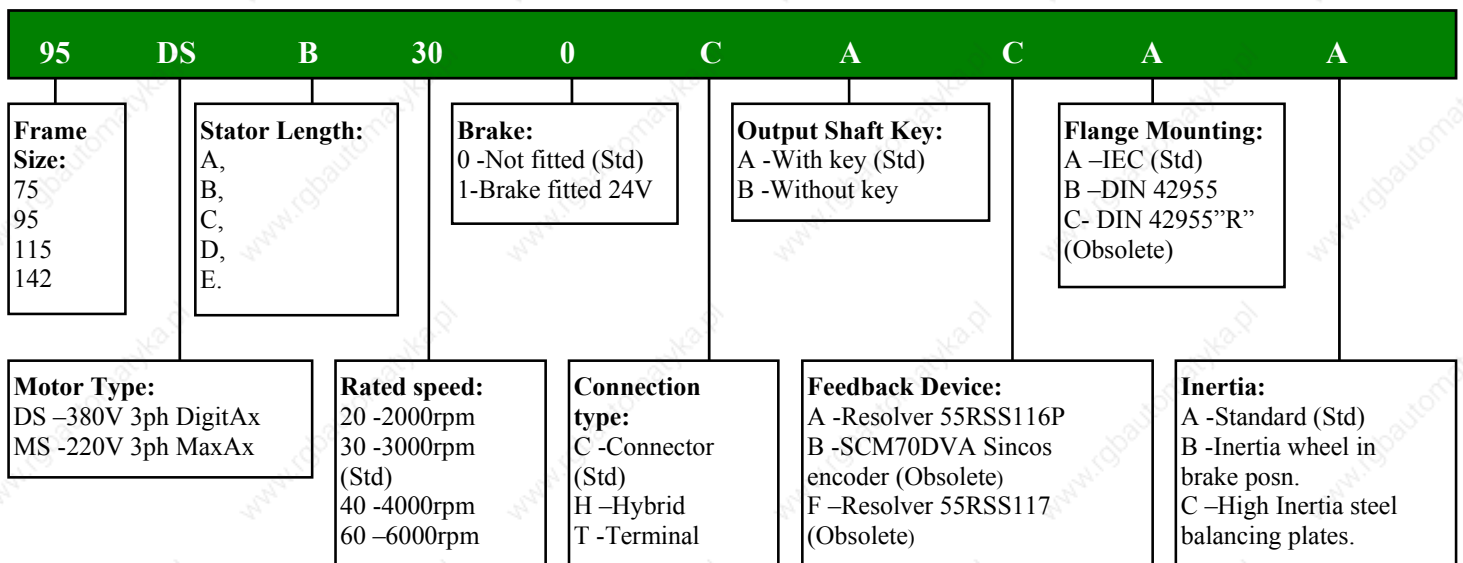

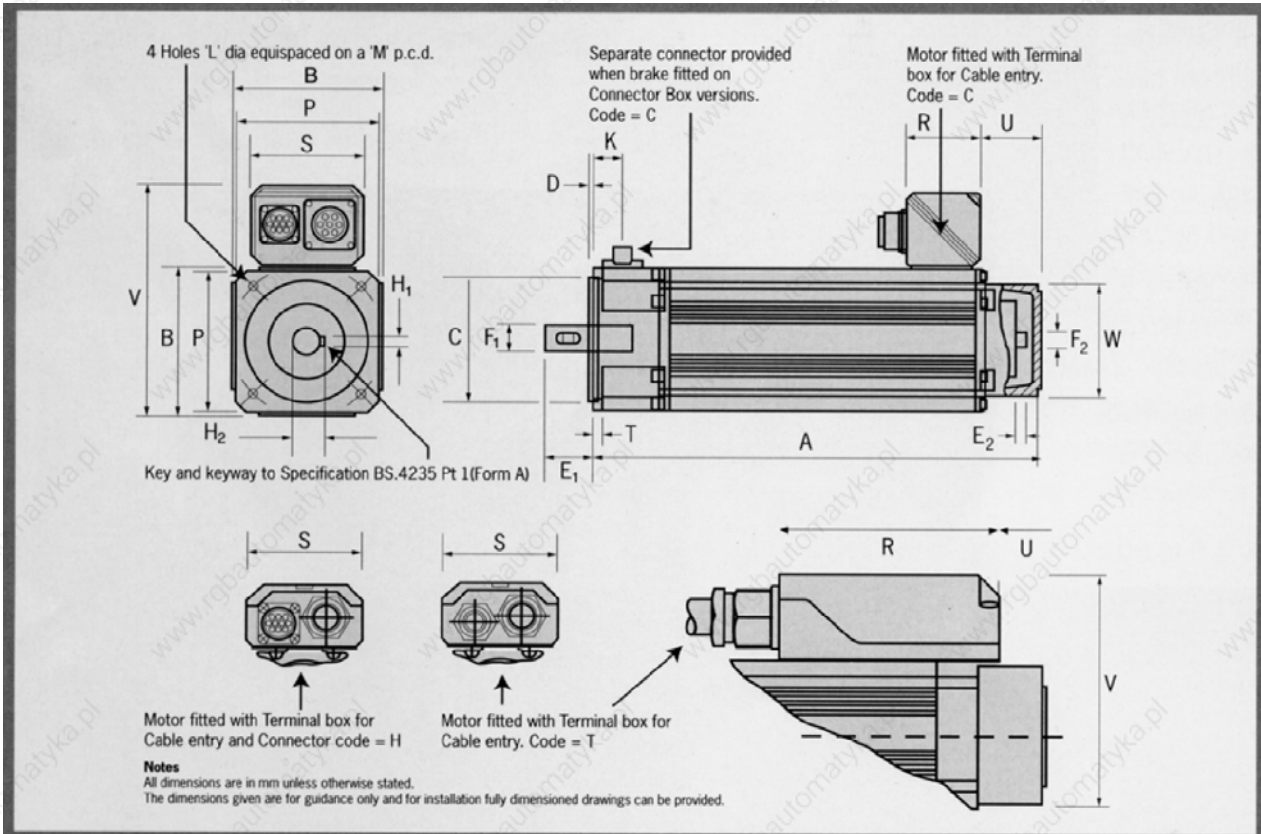
Dimensions

Frame Size	75DS					95DS					115DS					142DS				
Dimension/Length suffix	A	B	C	D	E	A	B	C	D	E	A	B	C	D	E	A	B	C	D	E
A Length Overall	225	254	283	312	351	235	264	293	322	351	245	274	303	332	361	275	303	332	361	390
B Body Square	75.5					95.5					115.6					143.0				
C Register Diameter	59.993/60.012					79.993/80.012					94.991/95.013					129.989/130.014				
D Register Length	2.5					3					3					3				
E1 Shaft Length (Front)	23	30				30	40				40	50				50				
E2 Shaft Length (Rear)	10.40/11.60					10.40/11.60					10.40/11.60					10.40/11.60				
F1 Shaft Diameter (Front)	11	14				14	19				19	24				24				
F2 Shaft Diameter (Rear)	12					12					12					12				
H1 Shaft key Width	4	5				5	6				6	8				8				
H2 Shaft Key Height	12.5	16				16	21.5				21.5	27				27				
K Brake Connector Location	16					16.3					14					21.5				
L Fixing Hole Diameter	5.8					7					9					11.5				
N Fixing Hole p.c.d.	75					100					115					165				
P Flange Square	70.0/70.5					92.0/92.5					105.0/105.5					142.0/143.0				
T Flange Thickness	5.8/6.2					5.8/6.2					8.8/9.2					10.8/11.0				
W Resolver Cover Diameter	71					71					71					71				
Connector Version (C)																				
R Connector Box Length	48.4					48.4					48.4					52.4				
S Connector Box Width	74					74					74					92				
U Connector Box Location	53.4					38.4					42.4					42.4				
V Overall Height	125					145					165					196				
Terminal/Hybrid Box (T/H)																				
R Connector Box Length	110					110					110					110				
S Connector Box Width	76					76					76					76				
U Connector Box Location	23.8					8.8					12.9					12.8				
V Overall Height	119					139					159					190				

Connections
Connectors

MOTOR		SIGNAL		BRAKE	
PIN	FUNCTION	PIN	FUNCTION	PIN	FUNCTION
A	U	A	Excitation high	A	0V
B	V	B	Excitation low	B	
C	W	C	Cos low	C	24V d.c.
D		D	Cos high		
E		E	Sin high		
F		F	Sin low		
G	EARTH	G			
		H			
		J	Thermistor		
		K	Thermistor		

Power connector 7way small fitted to 75 DS-95 DS motors.

Power connector 7way large fitted to 115 DS-142 DS motors.

Terminal

MOTOR			SIGNAL		
COLOUR	SOCKET	FUNCTION	COLOUR	SOCKET	FUNCTION
Red	U	U	Red/White	1	Excitation high
Orange	V	V	Black/White	2	Excitation low
Yellow	W	W	Black	3	Cos low
			Red	4	Cos high
			Blue	5	Sin high
			Yellow	6	Sin low
			(Blue)	7	Thermistor
			(Red)	8	Thermistor

Hybrid

MOTOR			SIGNAL		
COLOUR	SOCKET	FUNCTION	COLOUR	PIN	FUNCTION
Red	U	U	Red/White	A	Excitation high
Orange	V	V	Black/White	B	Excitation low
Yellow	W	W	Black	C	Cos low
			Red	D	Cos high
			Blue	E	Sin high
			Yellow	F	Sin low
			(Blue)	J	Thermistor
			(Red)	K	Thermistor

Performance Data

DutymAx Performance Data - DS Version : 380V 3ph. 50/60 Hz

resolver feedback

* Value at ambient Temperature of 25 °C with ΔT of 125 °C

Data is subject to a tolerance of ± 10%

Motor Type Reference All versions (rpm)	75DS				95DS					115DS				142DS					
	A	B	C	D	A	B	C	D	E	A	B	C	D	E	A	B	C	D	E
Cont. T _{stall} * (Nm)	1.3	2.3	3.1	4.0	2.5	4.3	6.0	7.6	9.2	4.5	7.4	10.5	13.3	15.7	7.0	12.0	17.0	22.0	26.0
T _{peak} (Nm)	3.9	6.9	9.3	12.0	7.5	12.9	18.0	22.8	27.6	13.5	22.2	31.5	39.9	47.1	21.0	36.0	51.0	66.0	78.0
High Inertia (Kgcm ²)	1.1	1.6	2.1	2.5	3.4	4.5	5.6	6.8	7.9	9.3	12.2	15.0	17.7	20.5	28.2	34.3	40.4	46.5	52.7
Standard In (Kgcm ²)	0.6	1.1	1.6	2.0	1.5	2.6	3.7	4.9	6.0	4.2	7.1	9.9	12.6	15.4	8.5	14.6	20.7	26.8	33.0
Weight (Kg)	3.0	3.7	4.4	5.1	5.0	6.1	7.2	8.3	9.5	6.5	8.2	9.9	11.6	13.2	10.9	13.2	15.5	17.8	20.5
Motor Time (sec)	1315	1431	1500	1587	1422	1618	1800	1997	2178	1436	1614	1792	1980	2158	2093	2316	2548	2700	3003
Wndg Time (sec)	refer UM data																		
Rated Speed: 2000 (rpm)				Kt (Nm/A _{rms}): 2.4					Ke (V _{rms} /krpm): 147.0										
T _{rated} * (Nm)	1.2	2.1	2.9	3.7	2.3	4.0	5.5	7.1	8.5	4.1	6.7	9.5	12.0	14.2	6.5	11.4	16.2	20.4	23.7
Cont. I _{stall} * (A _{rms})	0.6	1.0	1.3	1.7	1.1	1.8	2.5	3.2	3.9	1.9	3.1	4.4	5.6	6.6	3.0	5.0	7.1	9.2	10.9
P _{rated} * (kW)	0.25	0.44	0.61	0.77	0.48	0.84	1.15	1.49	1.78	0.86	1.40	1.99	2.51	2.97	1.36	2.39	3.39	4.27	4.96
R (ph-ph) (Ohms)	172.6	56.1	28.8	19.9	52.0	16.5	8.8	5.8	4.3	27.8	8.6	4.6	3.0	2.2	13.4	4.0	2.1	1.4	1.0
L (ph-ph) (mH)	243.1	106.4	67.9	49.3	138.9	64.9	41.2	29.6	23.2	94.6	40.5	25.7	18.6	14.7	58.0	29.8	18.7	13.6	10.7
Rated Speed 3000 (rpm)				Kt (Nm/A _{rms}): 1.6					Ke (V _{rms} /krpm): 98.0										
T _{rated} * (Nm)	1.2	2.1	2.8	3.6	2.3	3.9	5.4	6.9	8.3	3.7	6.1	8.6	10.8	12.7	6.0	10.0	13.5	17.5	20.0
Cont. I _{stall} * (A _{rms})	0.9	1.5	2.0	2.5	1.6	2.7	3.8	4.8	5.8	2.9	4.7	6.6	8.4	9.9	4.4	7.5	10.7	13.8	16.3
P _{rated} * (kW)	0.38	0.66	0.88	1.13	0.72	1.23	1.70	2.17	2.61	1.16	1.92	2.70	3.39	3.99	1.88	3.14	4.24	5.50	6.28
R (ph-ph) (Ohms)	73.4	23.4	13.9	8.7	24.9	7.5	4.1	2.8	1.9	12.6	3.9	2.0	1.3	1.1	6.0	1.8	0.9	0.6	0.4
L (ph-ph) (mH)	109.0	47.7	31.5	22.8	63.5	28.5	18.3	13.2	10.3	43.1	18.6	11.4	8.6	7.4	31.0	13.3	8.3	6.1	4.8
Rated Speed 4000 (rpm)				Kt (Nm/A _{rms}): 1.2					Ke (V _{rms} /krpm): 73.5										
T _{rated} * (Nm)	1.1	2.0	2.4	3.0	2.0	3.0	4.0	4.9	5.8	3.1	4.9	6.7	7.8	8.6	4.0	7.8	9.9	11.9	13.5
Cont. I _{stall} * (A _{rms})	1.1	2.0	2.6	3.4	2.1	3.6	5.0	6.4	7.7	3.8	6.2	8.8	11.1	13.1	5.9	10.0	14.2	18.4	21.7
P _{rated} * (kW)	0.46	0.84	1.01	1.26	0.84	1.26	1.68	2.05	2.43	1.30	2.05	2.81	3.27	3.60	1.68	3.27	4.15	4.98	5.65
R (ph-ph) (Ohms)	43.7	14.2	7.7	4.6	13.8	4.4	2.4	1.7	1.2	6.9	2.1	1.2	0.7	0.6	3.4	1.0	0.5	0.4	0.2
L (ph-ph) (mH)	61.7	27.2	18.1	12.7	35.9	16.1	10.1	7.6	5.8	23.5	10.2	6.6	4.7	3.9	17.6	7.5	4.7	3.6	2.7
Rated Speed 6000 (rpm)				Kt (Nm/A _{rms}): 0.8					Ke (V _{rms} /krpm): 49.0										
T _{rated} * (Nm)	1.0	1.5	1.8	2.0															
Cont. I _{stall} * (A _{rms})	1.7	2.9	3.9	5.0															
P _{rated} * (kW)	0.63	0.94	1.13	1.26															
R (ph-ph) (Ohms)																			
L (ph-ph) (mH)																			

The information contained in this specification is for guidance only and does not form part of any contract.

CT Dynamics Limited have an ongoing process of development and reserve the right to change the specification without notice.

Data reviewed Nov 2002