

H6D-T

Lathe CNC Controller

Manual

Ver : Nov. , 2013

HUST Automation Inc.
No. 80 Kon Yei Road, Toufen, Miaoli, Taiwan
Tel: 886-37-623242
Fax: 886-37- 623241

TABLE OF CONTENTS

| | | |
|----------|--|------------|
| 1 | H6D-T Main Features of CNC Lathe Controller | 1-1 |
| 2 | Operation | 2-1 |
| 2.1 | Basic Operation | 2-1 |
| | Screen Description | 2-1 |
| | Startup Screen | 2-1 |
| | MPG – TEST Screen | 2-2 |
| | Auto Mode Screen | 2-3 |
| | MDI Mode Screen | 2-7 |
| | Edit Mode display | 2-10 |
| | Program Selection Screen | 2-14 |
| | Jog Mode Screen | 2-16 |
| | MPG Mode Screen | 2-17 |
| | Home Mode Screen | 2-18 |
| | I/O Mode Screen | 2-19 |
| | Parameter Screen | 2-21 |
| | Software Version Screen | 2-22 |
| | System Parameter Screen | 2-23 |
| | Tool Radius | 2-25 |
| | Tool Compensation Screen | 2-27 |
| | G54~G59: Work coordinate setting page | 2-29 |
| | Error message | 2-30 |
| | Graph Mode Screen | 2-30 |
| 2.2 | Program Editing | 2-31 |
| 2.2.1 | Programming Overview | 2-31 |
| 2.2.1.1 | Part Programs | 2-31 |
| 2.2.1.2 | Programming Methods | 2-31 |
| 2.2.1.3 | Program Composition | 2-33 |
| 2.2.1.4 | Coordinate System | 2-35 |
| | Coordinate Axis | 2-36 |
| | Coordinate Positioning Control | 2-36 |
| | Work Origin | 2-39 |
| | Machine Origin | 2-40 |
| 2.2.1.5 | Numerical Control Range | 2-41 |

| | | |
|---------|------------------------|------|
| 2.2.2 | Program Editing | 2-42 |
| 2.2.2.1 | Creating a New Program | 2-42 |
| 2.2.2.2 | Editing a Program | 2-43 |
| 2.2.2.3 | Entering Fractions | 2-48 |
| 2.2.2.4 | Editing Notes | 2-48 |

□ □ M Codes □1

| | | |
|--------|---|------|
| 3.1 | Command codes | 3-1 |
| 3.2 | Positioning □G00 | 3-4 |
| 3.3 | Linear Cutting □G01 | 3-5 |
| 3.4 | G02 □G03 Circular Interpolation | 3-7 |
| 3.5 | Dwell Command □G04 | 3-11 |
| 3.6 | Parabolic Cutting □G05 | 3-12 |
| 3.7 | Exact Stop Check □G09 □G61 □G62 | 3-15 |
| 3.8 | Spindle Positioning Command □G15 | 3-16 |
| 3.9 | Cylindrical Plane □G16 | 3-16 |
| 3.10 | Plane setup □G17-G19 | 3-20 |
| 3.11 | Automatic Reference Position Return □G28 | 3-23 |
| 3.12 | Return From Reference Position □G29 | 3-24 |
| 3.13 | 2nd Reference Position Return □G30 | 3-25 |
| 3.14 | Thread Cutting □G32 | 3-26 |
| 3.15 | G33 Tapping Cutting Canned Cycle | 3-30 |
| 3.16 | G34 Variable Lead Thread Cutting | 3-31 |
| 3.17 | Canned Cycle Functions □For implication of programming□ | 3-36 |
| 3.17.1 | Single Cutting Canned Cycle □G90 □G92 □G94 | 3-36 |
| | Longitudinal Cutting Fixed Cycle □G90 | 3-36 |
| | Outer/Inner Diameter Tapered Lateral Canned Cycle □G90 | 3-37 |
| | Thread Cutting Fixed Cycle □G92 | 3-38 |
| | Tapered Thread Cutting Canned Cycle □G92 | 3-39 |
| | Face Cutting Fixed Cycle □G94 | 3-40 |
| | Face Cutting Fixed Cycle □G94 | 3-41 |
| 3.17.2 | Compound Canned Cycle Functions □G70~G76 | 3-42 |
| | Finishing Cycle □G70 | 3-43 |
| | Longitudinal Rough Cutting Cycle □G71 | 3-43 |
| | Face Rough Cutting Cycle □G72 | 3-47 |
| | Formed Material Rough Cutting Cycle □G73 | 3-50 |

| | | |
|--------|--|-------|
| | Face Cut-Off Cycle□G74 | 3-53 |
| | Longitudinal Cut-Off Cycle□G75 | 3-56 |
| | Compound Thread Cutting Canned Cycle□G76 | 3-58 |
| | Notes on Compound Canned Cycle □G70~G76□ | 3-61 |
| 3.18 | G50 Coordinate system □ Spindle clamp speed setting | 3-62 |
| 3.19 | Constant Surface Cutting Speed Setting□G96 | 3-63 |
| 3.20 | Cutting Speed Cancellation□G97 | 3-64 |
| 3.21 | Feed-rate Setting□G98□G99 | 3-64 |
| 3.22 | Inch/Metric Measurement Mode □G20□G21 | 3-64 |
| 3.23 | Deep Drilling Canned □peck drill□Cycle G83□G80 | 3-65 |
| 3.24 | Tapping Cycle G84□G80 | 3-65 |
| 3.25 | Auxiliary Functions□ <u>M-code</u> □ <u>S-code</u> | 3-68 |
| 3.26 | Subprograms | 3-71 |
| | Structure of the Subprogram | 3-71 |
| | Execution of the Subprogram | 3-71 |
| 3.27 | Tool Radius Compensation | 3-65 |
| 3.27.1 | Total Offset Compensation Setting and Cancellation | 3-65 |
| 3.27.2 | Tool-tip Radius and the Direction of Fictitious Tool-tip□G41□ G42□G40 | 3-66 |
| 3.27.3 | Interference Check | 3-86 |
| 3.27.4 | Notes on Tool Radius Compensation | 3-89 |
| 3.28 | Coordinate System | 3-91 |
| 3.28.1 | Local Coordinate System Setting□G52 | 3-91 |
| 3.28.2 | Basic machine coordinate system □G53 | 3-92 |
| 3.28.3 | Work Coordinate System□G54~G59 | 3-93 |
| 3.29 | Corner chamfer □C□□□round-angle chamfer □R□□functions | 3-96 |
| 3.29.1 | Chamfer □□C□□□ | 3-96 |
| 3.29.2 | Round-angle chamfer □□R□□ | 3-98 |
| 3.30 | Liner angle function □□A□□ | 3-99 |
| 3.31 | Geometry function command | 3-101 |
| 3.32 | Automatic calculation of Line-Arc intersection point | 3-104 |

□ MCM □ara□eters

□1

| | | |
|-------|------------------|-----|
| 4.1 | MCM Parameters | 4-1 |
| 4.1.1 | Basic Parameters | 4-1 |
| 4.1.2 | MCM Parameters | 4-1 |

| | | |
|-----|---------------------------|-----|
| 4.2 | Description of Parameters | 4-5 |
|-----|---------------------------|-----|

□ Connections □1

| | | |
|-------|--|------|
| 5.1 | System Connection Descriptions | 5-1 |
| 5.2 | System Installation | 5-2 |
| 5.2.1 | Operating Environment | 5-2 |
| 5.2.2 | Considerations for the design of control panel | 5-2 |
| 5.2.3 | Internal temperature design | 5-2 |
| 5.3 | H6D-T External Dimensions | 5-4 |
| 5.3.1 | H6D-T Controller | 5-4 |
| 5.3.2 | H6DL-T Controller | 5-6 |
| 5.3.3 | H6D-T Auxiliary Panel | 5-8 |
| 5.3.4 | H6DL-T Auxiliary Panel | 5-9 |
| 5.3.5 | H6D-T Accessories Dimensions | 5-10 |
| 5.4 | Connector Type | 5-12 |
| 5.5 | Connector Name | 5-12 |
| 5.6 | Connector Pin-out Definition | 5-13 |
| | Axis Connector Pin | 5-13 |
| | MPG □H6D□ | 5-14 |
| | MPG □H9D□ | 5-15 |
| | AD/DA Analog Signal Wiring | 5-16 |
| 5.6.1 | G31 INP□T Control Signals | 5-17 |
| 5.6.2 | Axial Control□pin assignment and wiring | 5-18 |
| 5.6.3 | Wiring of Manual Pulse Generator □MPG□ | 5-19 |
| 5.6.4 | Wiring of Spindle Control | 5-20 |
| 5.6.5 | I/O Wiring | 5-22 |
| 5.6.6 | I/O Wiring Schematic | 5-24 |
| 5.6.7 | Wiring of System AC Power Supply | 5-30 |
| 5.6.8 | Servo on Wiring Examples | 5-31 |

6 □rror Messa□es □1

□ Appendi□□ □1

| | | |
|-----|--------------------------------------|------|
| 7.1 | Description of MCM Machine Constants | 7-22 |
|-----|--------------------------------------|------|

Appendix A

| | |
|-----------------------------|-----|
| Input Planning | 8-1 |
| Input Signal Format Setting | 8-2 |
| Output Point Planning | 8-2 |

Appendix B - CNC On-Line Operation

| | | |
|--------|--|------|
| 9.1 | PC Performs Online Operation via RS232 and The Controller | 9-1 |
| 9.1.1 | Program Transfer From PC To CNC Controller | 9-2 |
| 9.1.2 | Program Transfer from CNC Controller to PC | 9-3 |
| 9.1.3 | Transfer MCM Data from PC to CNC Controller | 9-4 |
| 9.1.4 | Transfer MCM Data from CNC Controller to PC | 9-5 |
| 9.1.5 | Transfer Data Variable from PC to CNC controller | 9-5 |
| 9.1.6 | Transfer Data Variable from CNC controller to PC | 9-5 |
| 9.1.7 | Transfer PLC Ladder from PC to CNC controller | 9-6 |
| 9.1.8 | Transfer LCD Screen Display Data from PC to CNC | 9-7 |
| 9.1.9 | Transfer Controller System Data from PC to CNC | 9-7 |
| 9.1.10 | Transfer function tables from PC to CNC controller | 9-8 |
| 9.1.11 | PC to Controller ARM | 9-8 |
| 9.1.12 | HCON.E Program Operation | 9-9 |
| 9.1.13 | RS232C Connection | 9-12 |
| 9.2 | HST H6C-T Transmission Modes | 9-13 |
| 9.3 | SB Device Mode | 9-14 |
| 9.4 | SB Host Mode | 9-14 |
| 9.5 | Operational Instruction of A Standard H6C-T Transmission Interface | 9-14 |
| 9.5.1 | File Download Interface | 9-15 |
| 9.5.2 | File Upload Interface | 9-18 |

Appendix C - Method for using the most often used commands and

Appendix D - Servo Motor Wiring

Main-Features of HUST H6D-T Lathe CNC Controller

- Available for operation with a maximum of 6 axes (depending on the actual model number).
- It can be worked with impulse command or voltage command type of server system. Max. response speed will be 2,500,000 impulses per second (2500 KPPS). When operated at 1 μ m resolution, it can even reach 150m per minute.
- It achieves 0.5 μ s of response speed for fast acceleration/deceleration control, which is faster than 2ms response of conventional CNS digital control for 4000 times.
- Simultaneous operation of speed control and position control in providing a flexible option for the customer.
- Encoder feedback function is provided for speed control and position control. It not only achieves accurate position judgment and much easier failure detection but can prevent the mechanical conflict in a more effective way.
- It can flexibly work with Optical Scale for performing fully closed loop control in achieving more accurate position alignment.
- Automatic identification of NPN, PNP signal format at the input point without the need to shift the switch. Further, the electrical layout is configured in a more convenient manner for easier and flexible operation.
- When activating the special action control mode, it achieves faster working speed than the ordinary digital control model while providing much higher efficiency and more stabilized performance.
- It is available for designing convenient LCD screen for displaying the editing system on LCD. Simple and easier for learning. Further, the user can also select PC screen to display the edit software to carry out monitoring or program inspection. Through RS232 interface, the user can transmit the data on PC and run the program (hands-on learning) or execute the transmission directly via USB, SD card interface.

- Program Designed by CAD/CAM on PC. Program input from PC through RS232C interface.
- Based on varied characteristics of CNC models, the MCM Parameter Setting Table can be used to set the mechanical parameters for enhancing the amiability of the machine.
- Using the well-based Tool management function, the customer can set up 40-tool lifespan management and select the desired operation count, time limit.
- Provide 40 sets of tool-length offsets.
- It is equipped with gear gap compensation function for adjusting the gear gap error after using the Guide Stud. Further, it also has 40-section pitch compensation function to offset the pitch wearing in different sections.
- It is provided with 6 sets of working coordinate system setting functions to facilitate the program design and Workpiece machining.
- Full follow-up type of tapping mode in achieving more perfect thread, more accurate thread depth control and faster speed.
- Each axis can be set as active, passive mode or single-node non-stop mode.
- It is equipped with gear gap compensation function for adjusting the gear gap error after using the Guide Stud. Further, it also has the 40-section pitch compensation function to offset the pitch wearing in different sections.
- It is provided with 6 sets of working coordinate system setting functions to facilitate the program design and Workpiece machining.
- Full follow-up type of tapping mode in achieving more perfect thread, more accurate thread depth control and faster speed.
- Each axis can be set as active, passive mode or single-node non-stop mode.

- Self-diagnostic and error signaling function.
- MPG hand-wheel test and collision free function for cutting products at the speed controller by MPG.
- IO Module is designed with separate Transition Board and Signal Board in achieving lower maintenance cost, simpler installation and more stabilized performance.
- Provided with standard 24 input points and 16 output points (optional single-piece Transition Board can be selected to provide 48 input points and 32 output points) of programmable logic control. It can be expanded up to 256 input point and 176 output points of programmable logic control.

This operator's manual includes basic operation, program editing, G/M code, parameter settings, connections and maintenance (plus warning descriptions) with examples and explanations for each command.

If there are any problems with the application, please fill out a problem sheet indicating the nature of the problem. Send it by either fax or mail. We will respond as soon as possible.

2 Operation

2.1 Basic Operation

Screen Description

Startup Screen

After powering the controller, the following startup screen displays:



Fig. 2-1

After 3 seconds, the next screen displays according to the “Mode Selection” setting. When turning the “PRNO” knob from left to right, the following modes are displayed in order:

“MPG - TEST” → “AUTO” → “MDI” → “EDIT” → “PRNO” → “JOG” → “MPGx1” → “MPGx10” → “MPGx100” → “HOME”

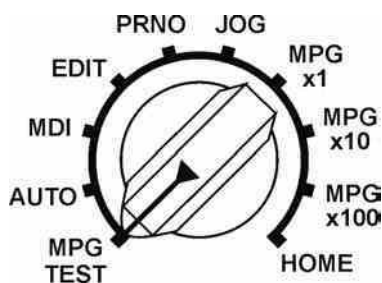

Fig. 2-2

Controller buttons function key following order from left to right: “RESET” → “IO/MCM” → “TOOL RADIUS” → “TOOL OFFSET” → “GRAPH”

□ **M□□ – T□□T □□reen**

The following screen displays when the “Mode Selection” knob is set to “MPG – TEST”:

| | | | |
|---------------------------------|-----------------------------|-----------------------------------|-------------------------------|
| PRNO: 000/G98/L : 0000/N : 0000 | | 99/99 99:99 | |
| Program coordinate | | Machine Dis to go | |
| ● X -0000.000 | -00000 -0000.000 -0000.000 | MPG x 000 | G01 :% 000 |
| ● Y -0000.000 | -00000 -0000.000 -0000.000 | G00 :% 000 | M : 0000 |
| ● Z -0000.000 | -00000 -0000.000 -0000.000 | T : 0000 | Feed rate: |
| → C -000.000 | rpm:0000 S1: 0000 SS0%: 000 | 000.000 | |
| → A -000.000 | rpm:0000 S2: 0000 SS0%: 000 | | |
| → B -000.000 | rpm:0000 S3: 0000 SS0%: 000 | | |
| Current execution block: 0000 | | Total processing time(s): 0000000 | |
| | | Count: 0000000 | |
| Coolant pump error | | TEST | HOLD |
| SEMI Automation | MPG x10 | Restart | MPG interrupt Preview program |

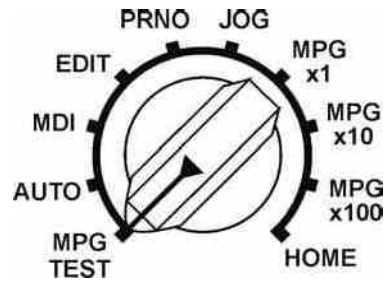

Fig. 2-3

After this mode is selected, the movement of all axes in the program is controlled by the MPG when the program is running. The axis will stop moving when the MPG has no input.

In this mode, the program process will proceed in order when the program is running, regardless of the direction of the hand-wheel. The program process will not return when the hand-wheel is rotated anti-clockwise.

Press the F7 Key to shift the multiple of MPG Hand Wheel as X1, X10 and X100 alternately, and other function keys will be the same as the Auto Mode. Please refer to Auto Mode function key description.

□ **Auto Mode** □ **reen**

The following screen displays when the “Mode Selection” knob is set to “Auto”:

| | | | |
|---------------------------------|----------|-----------------------------------|-----------------|
| PRNO: 000/G98/L : 0000/N : 0000 | | 99/99 99:99 | |
| Program coordinate | Machine | Dis to go | MPG X 000 |
| ● X -0000.000 | -00000 | -0000.000 | -0000.000 |
| ● Y -0000.000 | -00000 | -0000.000 | -0000.000 |
| ● Z -0000.000 | -00000 | -0000.000 | -0000.000 |
| ➔ C -000.000 | rpm:0000 | S1: 0000 | SS0%: 000 |
| ➔ A -000.000 | rpm:0000 | S2: 0000 | SS0%: 000 |
| ➔ B -000.000 | rpm:0000 | S3: 0000 | SS0%: 000 |
| | | G01 : % 000 | G00 : % 000 |
| | | M : 0000 | T : 0000 |
| | | Feed rate: 000.000 | |
| Current execution block: 0000 | | Total processing time(s): 0000000 | |
| | | Count: 0000000 | |
| Coolant pump error | | AUTO | HOLD |
| SEMI Automation | MPG x10 | Restart | MPG interrupt |
| | | | Preview program |

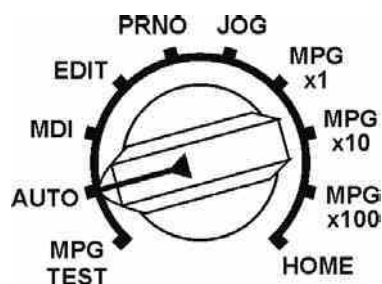

Fig. 2-4

- 1 □ **Parameter Monitorin** □ Select under Auto Mode, Program Est. Mode and MDI Mode (for the engineering technician). Under the aforesaid mode, press the F1 Key to access the Variation monitoring screen. Under Variation monitoring screen, enter the variation address to be monitored and it will display the real-time value of such variation address.
- 2 □ **Servo Monitorin** □ Select under Auto Mode, Program Est. Mode and MDI Mode (for the engineering technician). Under the aforesaid mode, press F3 Key to access the “Servo Monitoring” screen. Under this screen, select the axis to be monitored and the user can monitor the real-time command of each axis and the Servo responding status.
- □ **Restart** □ Select only before running the program.
 - (1) In the “Edit Screen” (as per Fig. 2-8 below), you may search the interrupted node or reset for restarting such node. Press F4 Key after completing the search or setting; when “Restart” indicates reverse white, it means such function is active.
 - (2) Under Auto screen, press F4 Key to select or cancel the function restarting. When “Restart” indicates reverse white, it means such function is closed; otherwise, it will be cancelled. After pressing “Start” key to run the program again, the program will start running from the previously interrupted node or the “Restart” node being set.

① When setting “If to grab previous node when restarting” parameter item as “0”, the system will grab the previous node after pressing “Start” key and

the program will advance to the “Set Restart” node of the previous node for the system to run the program of this node and the one that follows. ② When setting “If to grab previous node when restarting” parameter item as “1”, , the system will not grab previous node after pressing “Start” key; instead, the program will run in the direction from “Set Restart” node.)

- **□e□i□uto□□uto□** When setting “If setting the program as Auto Start” of the mechanical parameters as “1” (required), the F6 Key will display “Semi-Auto/Auto” for the user to shift between Semi-Auto and Auto working modes via F6 Key.

Semi-Auto: When the program reaches M02/M30, the working will end.

Auto: When the program reaches M02/M30, the working will not stop and will start automatic cycle for processing the next Workpiece.

During running the working program, the user may shift between Semi-Auto and Auto via F6 Key.

- **□re□ie□ □ro□ra□□** Select under Auto and Program Est. mode to observe the program content.

Under Auto screen, press F8 Key to access the Preview screen, which will display the program content for the selected program number and then press F1 for returning to Auto screen.

- 6□ **M□ □top□** This function can be selected at all times whether under running or stopping status.

On Auxiliary Panel, press “M01 Stop” key to select or cancel the stopping function. When the “M01 Stop” indicator is on, it means such function is active; otherwise, it will be cancelled. Upon activating the “M01 Stop” function, the “M01 Command” in the program will be deemed as stopping command; however, the “M01 Command” will become invalid if such function is not selected.

- **Node □□e□ution□** This function can be selected at all times whether under running or stopping status.

On Auxiliary Panel, press “Node Run” key to select or cancel such function. When the “Node Run” indicator is on, it means such function is active; otherwise, it will be cancelled. After selecting this function, it will not run the entire program upon each pressing of “Start” key; instead, the program on the next line will be executed

upon each pressing of “Start” key.

- **Node Skip** This function can be selected at all times whether under running or stopping status.

On Auxiliary Panel, press “Node Skip” key to select or cancel such function. When “Node Skip” indicator is on, it means such function is active; otherwise, it will be cancelled. When hitting “/1” Node during the execution after selecting this function, it will skip and will not execute such node.

- **Working Count and Time Indication** (as per Fig. 2-3):

- (1) **Set Count:** Set the limit value of the working count (to set under Parameter screen). When set value equals to 0, the maximum value of the working count will be limitless.
- (2) **Working Count:** When running to M15, an increment of “1” will be added. If manual reset is required, under Auto Display screen, quickly press “0” Key for twice and it will be reset to zero. Further, the user can also run “M16 Command” to clear the working count.
- (3) The program will stop automatically when the working count reaches the Set Count, therefore M15 Command should be located at the rearmost end of the working process. Upon reaching the working count, the screen will indicate the working count up message. At this time, the customer can restart the program using the Reset key or pressing the Start key directly to restart the program and reset the worked count to zero.
- (4) **Working Time:** Display the duration (second) of the program currently executed. When restarting the program after the program is interrupted or ended, it will reset to zero automatically.
- (5) **Calendar:** As per Fig. 2-3, the figures displayed under the “Working Time” represent the current time. The time can be set under “Software Version” screen.

- 1 □□ **Working Route Drafting** Under Auto Mode or Program Est. Mode, the customer can access the drafting screen by pressing the “Draft” key to observe the working route, as per Fig. 2-6.

- (1) **Display Percentage:** With Page Up/Page Down page key, you may adjust the displayed percentage of the working route flexibly in dynamic way.
- (2) **Display Position:** With Up/Down/Left/Right Direction Cursor key, you may adjust the graphical Home Position displayed in the screen or adjust the draft Home Position by letter keys in a quicker manner.

I-Screen Upper Left; J-Screen Middle Up; K-Screen Upper Right

R-Screen Middle Left; S-Screen Center; T-Screen Middle Right
 G-Screen Lower Left; F-Screen Lower Middle; M-Screen Lower Right

- (3) Coordinate Plane Shift: Letter X-XY Plane, Letter Y-YZ Plane, Letter Z-XZ Plane.
- (4) Clear the drafted working route: By pressing “Clear” key, you may erase the drafted working track from the Draft screen.
- (5) The drafting action will be divided into the the following two types: “Hands-on Draft”, “Fast Draft”.

Shift Method: Under Draft Mode and before starting the program, press “Fast” key (once for ON and press again for OFF).

Fast Key Indicator ON → “Fast Draft”
 Fast Key Indicator OFF → “Hand-on Draft”

“Hand-on Draft”: Servo axis displacement command together with M, T and S codes will be executed.

“Fast Draft”: Servo axis will be locked without displacement, but M, T and S codes will be executed.

Such function is useful for initial working, as the operator can check if the working route is correctly planned under absolute safe conditions.

- (6) Press “F1” Key to return to the Main Screen indicated by the current mode knob.

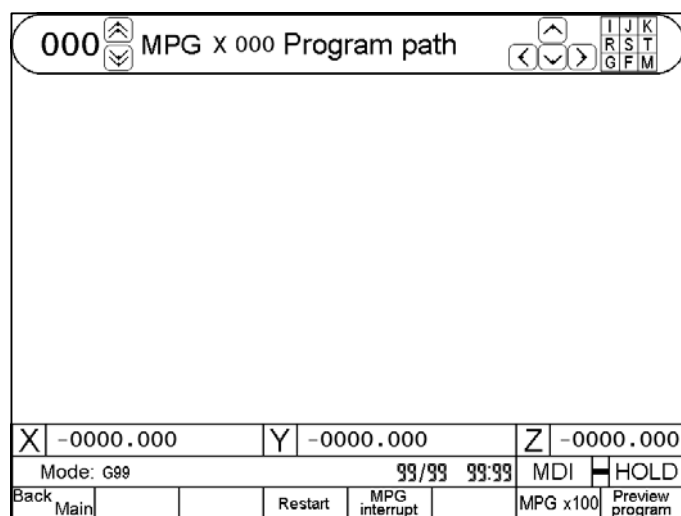

Fig. 2-7

□ MD Mode □reen

The following screen displays when the “Mode Selection” knob is in “MDI”:

| | | | |
|---------------------------------|-----------------------------|-----------------------------------|-----------------------|
| PRNO: 000/G98/L : 0000/N : 0000 | | 99/99 99:99 | |
| Program coordinate | | Machine | Dis to go |
| ● X -0000.000 | -00000-0000.000 | -0000.000 | -0000.000 |
| ● Y -0000.000 | -00000-0000.000 | -0000.000 | -0000.000 |
| ● Z -0000.000 | -00000-0000.000 | -0000.000 | -0000.000 |
| ➔ C -000.000 | rpm:0000 S1: 0000 SS0%: 000 | MPG x 000 | G01 :% 000 |
| ➔ A -000.000 | rpm:0000 S2: 0000 SS0%: 000 | G00 :% 000 | M : 0000 |
| ➔ B -000.000 | rpm:0000 S3: 0000 SS0%: 000 | T : 0000 | Feed rate: 000.000 |
| Current execution block: 0000 | | Total processing time(s): 0000000 | |
| | | Coolant pump error | |
| | | MDI | HOLD |
| File transfer | | Tool Life | |

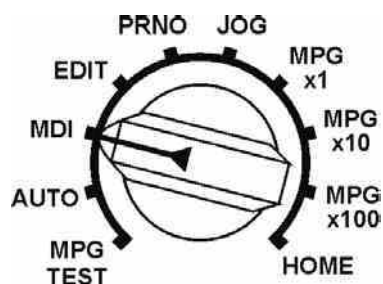

Fig. 2-8

Under this mode, input node command directly and press “Start” key and you can execute this node command immediately

Example:





1. Edit M03 S1000:
2. Press “Enter” key.
3. Press “Start” key.

After the above-said operation, the Spindle will make CW turning (speed: 1000 rpm/min).

11 **Tool Life** Under MDI Mode, press F5 Key to access (valid when the Tool Life management function is active).

| 0000 | | Tool Life Management | | | 0000.000 |
|---------------|---------|----------------------|-----------------|---------------------|-------------------------------|
| NO. | Count | Count Limit | Time (H:M:S) | Time Limit (H:M) | |
| 00 | 0000000 | 10000000 | 0000:00:00.0 | 0000:00 | |
| 00 | 0000000 | 10000000 | 0000:00:00.0 | 0000:00 | |
| 00 | 0000000 | 10000000 | 0000:00:00.0 | 0000:00 | |
| 00 | 0000000 | 10000000 | 0000:00:00.0 | 0000:00 | |
| 00 | 0000000 | 10000000 | 0000:00:00.0 | 0000:00 | |
| 00 | 0000000 | 10000000 | 0000:00:00.0 | 0000:00 | |
| 00 | 0000000 | 10000000 | 0000:00:00.0 | 0000:00 | |
| 00 | 0000000 | 10000000 | 0000:00:00.0 | 0000:00 | |
| X -0000.000 | | Y -0000.000 | | Z -0000.000 | |
| | | | | MDI | <input type="checkbox"/> HOLD |
| Back | Main | Count Limit | Time Limit | Data | Clear |

Fig. 2-5

- (1) Under MDI Mode, press the F5 Key to access the Tool Life management screen. In the Tool Life management screen, the upper left corner shows the Tool number currently executed and the upper right corner displays the current Tool service time for each individual machining.
- (2) The “Now Count” and “Now Time” at the upper part of the screen refer to the accumulation of count and time for each Tool service.
- (3) Press F4 Key to set the “Count Limit”. After selecting, the “Count Limit” at the upper part of the screen will indicate reverse white and flicker. At this time, use   to move to the edition position and set the corresponding limit of Tool service count.
- (4) Press F6 Key to set the “Time Limit”. After selecting, the “Time Limit” at the upper part of the screen will indicate reverse white and flicker. At this time, use   to move to the edition position for setting the corresponding limit of Tool service time.
- (5) Based on actual Tool service status, upper limit can be set simultaneously for “Count Limit” and “Time Limit”, which can also be used by choosing from either of the two.
- (6) Press and hold the F8 Key for executing “Clear All Figures”. When either the Count Limit or Time Limit reaches the upper limit, the system will indicate “Err39” alarm and the program being run will also stop at the position where T Code is located.
- (7) Page 1 of the parameter screen can be used for setting if to activate the Tool management function (double clicking the “I/O Para” key).

| | | | | |
|---|--------|--------------|--|--------------|
| G71,G72 go into | | -00.000 inch | Z-AXIS | -00.000 inch |
| G73 amount cutting | X-AXIS | -00.000 inch | Z-AXIS | -00.000 inch |
| G71,G72 retreat | | -00.000 inch | G73 segmentation | 0000 |
| G74,G75 retreat | | -00.000 inch | G76 fine cutting | 0000 |
| G76 Angle of tool tip | | 0000 | G76 chamfer Len | 0000 |
| G76 Depth of minimum cutting | | -00.000 inch | G76 retreat | -00.000 inch |
| MPG Direction $\frac{1}{2} \times \frac{2}{3} \times \frac{3}{4}$ | | 0 | Graphic proportion | 0000.000 |
| G84 dwell at bottom time | | 000000 | Multi-purpose MPG 1:yes | 0 |
| G84 Acc/Dec fine tuning time | | 000000 | 0:Diameter 1:Radius | 0 |
| G83 buffer distanceg | | 0000.000 | Chuck type 0:in 1:out | 0 |
| Chuck locked delay time | | 000000 | Metric 0:mm 1:inch | 0 |
| Wait for SP speed reaching | | 0 | Screensaver 0:yes | 0 |
| MPG-test feedrate Num. | | 0000 | Restart_skip M98 1:yes | 0 |
| MPG-test feedrate Den. | | 0000 | Non-stop 0:no 256:yes | 000 |
| Restart.MTS G04 0:skip 1:run | | 0 | TLM function 0:open 1:close | 0 |
| Restart.block refetch 0:yes | | 0 | Edit omit decimal 1:yes | 0 |
| Remaining days | | 0000000 | Lamp yellow <small>0:feed hold 1:M02/M30 2:all</small> | 0 |
| Tapping Acc/Dec time (ms) | | 0000 | Corner connection 1:G02/G03 2:G01/G04 | 0 |
| G41/G41 interference deal with 0/1/2 | | 0 | Use Y axis 1:yes | 0 |
| Coolant pump error | | | | |
| Back | | | SYSTEM | VERSION |
| Main | | | MCM | G54..G59 |

Fig. 2-6

□ **Edit Mode displa** □

The following screen displays when the “Mode Selection” knob is in “Edit”:

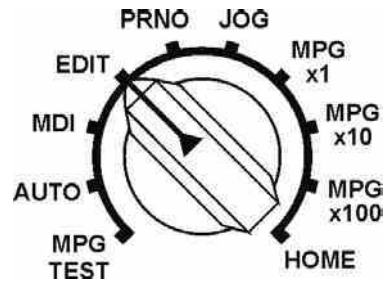
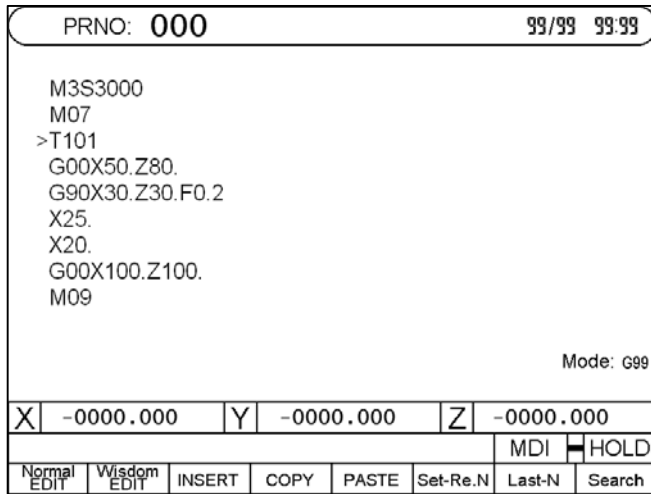

Fig. 2-9

□ **eneral** □ **ro** □ **ra** □ □ **in** □ **and** □ **ntelle** □ **tual** □ **ro** □ **ra** □ □ **in** □ □

Under Edit Mode, press the “F1” Key and you may select current editing mode for changing it to general programming status. By pressing “F2” Key, you may select current editing mode to change it to general programming status.

General programming: The letters and digits need to be input by the operator manually, and shown in Fig. 2-9 is the general programming status.

Intellectual Programming: The customer need not memorize the parameter letters of each command and relevant meaning, but needs to fill in the value following the respective parameter according to the illustration to complete the programming. In this way, it reduces the work load of the programmer, eases the programming difficulty, and enhances the programming efficiency. For relevant details, please refer to 2.2.3.

Copy and Paste

1. Press the “Copy” key and the screen will display “Please move the cursor to confirm the copy start node number for copy and then press the Enter key to confirm the selection” (as per Fig. 2-10).

| | | | | |
|---|----------------|--------|-----------|-----------------------------------|
| PRNO: 000 | | 000 | 000 99/99 | 99:99 |
| M3S3000 M07 >T101 G00X50.Z80. G90X30.Z30.F0.2 X25. X20. G00X100.Z100. M09 | | | | |
| Mode: G99 | | | | |
| Move cursor and press the Enter key to confirm the start block | | | | |
| X | -0000.000 | Y | -0000.000 | Z -0000.000 |
| | | | | MDI <input type="checkbox"/> HOLD |
| Normal EDIT | Wisdom EDIT | INSERT | COPY | PASTE Set-Re.N Last-N Search |

Fig.2-10

2. Move the cursor to the starting position of the block to be copied and then press “Enter” key to confirm (as per Fig. 2-11).

| | | | | |
|---|----------------|--------|-----------|-----------------------------------|
| PRNO: 000 | | 000 | 000 99/99 | 99:99 |
| M3S3000 M07 >T101 G00X50.Z80. G90X30.Z30.F0.2 X25. X20. G00X100.Z100. M09 | | | | |
| Mode: G99 | | | | |
| Move cursor and press the Enter key to confirm the end block | | | | |
| X | -0000.000 | Y | -0000.000 | Z -0000.000 |
| | | | | MDI <input type="checkbox"/> HOLD |
| Normal EDIT | Wisdom EDIT | INSERT | COPY | PASTE Set-Re.N Last-N Search |

Fig.2-11

3. Move the cursor to the ending position of the block to be copied and then press the “Enter” key to confirm (as per Fig. 2-12).

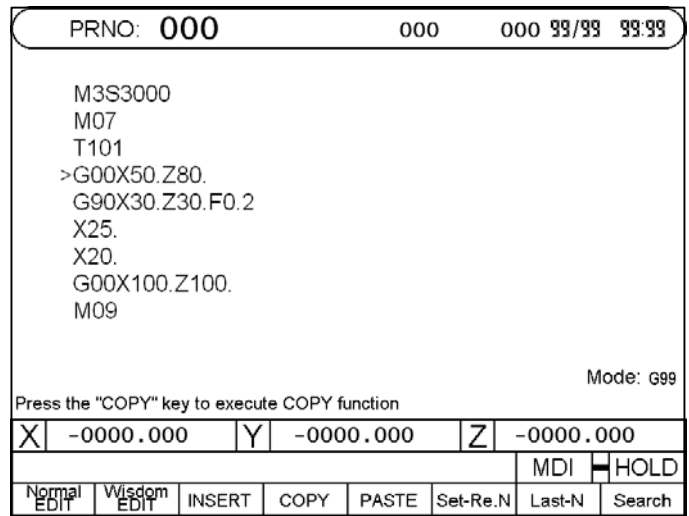

Fig.2-12

4. Press the “Hint” and then “Copy” key till the screen hint “Copy Done” appears (as per Fig. 2-13). To reselect the program content to be copied, repeat Step a~d.

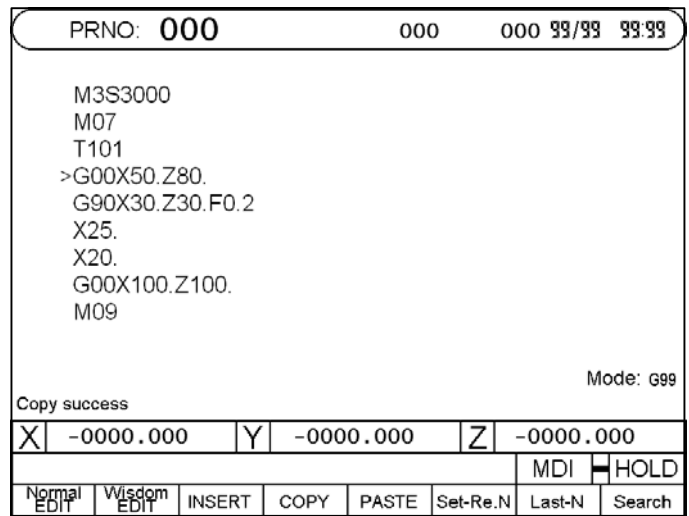

Fig.2-13

5. After completing the copying, move the cursor to the position to be pasted and then press “Paste” key to paste up the copied program block (as per Fig. 2-14). The copied program block can be pasted to the other program designated by program number and it can also be repeated pasted.

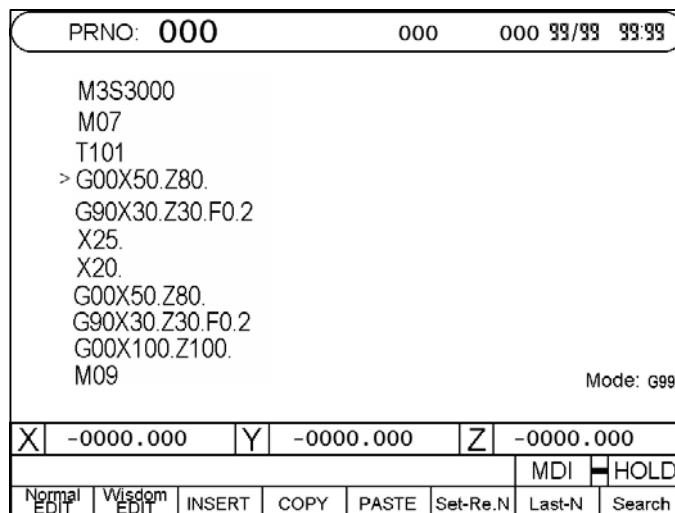



Fig. 2-14

- (1) Restart Again; In the edit program, move to the node to be restarted with   key and then press “Set Restart”, and the node is the set restart node. When the “Set Restart” indicates reverse white, it means such function is active.
- (2) Interrupt Node: To search the interrupted node after the program is interrupted during the working process (e.g. press Reset, emergency stop, shutdown), access the Edit screen and then press “Interrupted Node” soft key and it can be retrieved.
- (3) Search: To enter certain bit and value in the specific program node, press this key and the cursor will skip to the corresponding node position. To repeat, press “Search” key and the system will continue looking for the next bit that meets the requirements.

※ For detailed operation of program editing please refer to program editing section

Program Selection Screen

The following screen displays when the “Mode Selection” knob is set to “PRON”:

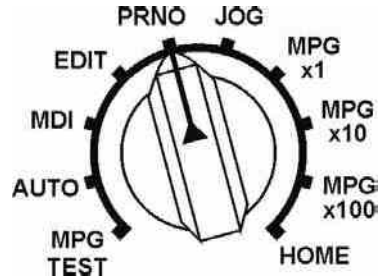
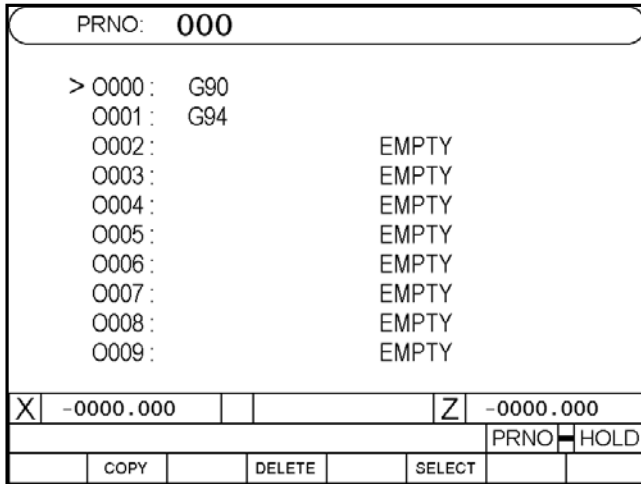

Fig. 2-15

Programable Line Numbers Range 6000
The controller stores uses numbers after 6000

You can enter program comments in this mode up to 12 characters.

Example: To add the comment “TYPE-201” to O001:





1. Move the cursor to O001

2. Press T Y P E 2 - 0 1 .

3. Press Enter .

Program Selection Methods

1. Select a program:
 - a. Use the “Cursor ↑ ↓” key or “Page ⏴ ⏵” key to move the arrow to the desired program number. (Press the Cursor ← → key that the program number will increase 100 for each time.)
 - b. Press the “Select” or “Enter” key.
2. Program comments:
 - a. Use the “Cursor ↑ ↓” key or “Page ⏴ ⏵” key to move the arrow to the program number for which program comments are entered.
 - b. Enter the desired comment using letters or numbers.









- c. Press the enter key.
3. Delete a program:
 - a. Use the “Cursor   ” key or “Page   ” key to move the arrow to the program number to be deleted.
 - b. When you press the “Delete” key, a dialogue prompts for confirmation.

Press the “YES” or “Y” soft key to delete the program.

Press the “NO” or “N” soft key to cancel the operation.
4. Copy a program:
 - a. Press the “Copy” key to display the following screen:

| | | | | | | |
|-----------------------|-----------|--------|------|---|-----------|------|
| PRNO: 000 | | | | | | |
| > O000 : G90 | | | | | | |
| O001 : G94 | | | | | | |
| O002 : EMPTY | | | | | | |
| O003 : EMPTY | | | | | | |
| O004 : EMPTY | | | | | | |
| O005 : EMPTY | | | | | | |
| O006 : EMPTY | | | | | | |
| O007 : EMPTY | | | | | | |
| O008 : EMPTY | | | | | | |
| O009 : EMPTY | | | | | | |
| SOURCE 000 TARGET 000 | | | | | | |
| X | -0000.000 | | | Z | -0000.000 | |
| | | | | | PRNO | HOLD |
| | SOURCE | TARGET | EXE. | | | |

Fig. 2-16

- b. Use the “Cursor   ” key or “Page   ” key to move the arrow to the source program number.
- c. Press the “Source” key
- d. Use the “Cursor   ” key or “Page   ” key to move the arrow to the objet (target) program number.
- e. Press the “Object” key

When the source and target program numbers are confirmed, press the “Execution” key to begin copying.

Mode screen

『MODE』 switch turn to 【JOG】 :

| | | | | | |
|-------------------------------|-----------|-----------------------------|-----------------------------------|------------------------|------------------------|
| PRNO: 000/G98/L: 0000/N: 0000 | | | 99/99 99:99 | | |
| Program coordinate | | [Error count] | Offset | | MPG x 000 |
| ● X | -0000.000 | -00000 | -0000.000 | G01 :% 000 | |
| ● Y | -0000.000 | -00000 | -0000.000 | G00 :% 000 | |
| ● Z | -0000.000 | -00000 | -0000.000 | M : 0000 | |
| ●→C | -000.000 | rpm:0000 S1: 0000 SS0%: 000 | | T : 0000 | |
| ●→A | -000.000 | rpm:0000 S2: 0000 SS0%: 000 | | Feed rate: | |
| ●→B | -000.000 | rpm:0000 S3: 0000 SS0%: 000 | | 000.000 | |
| Distance to go | | Relative | | Machine | |
| X: | -0000.000 | X: | -0000.000 | X: | -0000.000 |
| Y: | -0000.000 | Y: | -0000.000 | Y: | -0000.000 |
| Z: | -0000.000 | Z: | -0000.000 | Z: | -0000.000 |
| Current execution block: 0000 | | | Total processing time(s): 0000000 | | |
| | | | Count: 0000000 | | |
| Coolant pump error | | | | HOME | HOLD |
| SP-ZERO | SP-FREE | Spindle 1 | X opposite --- zero | Y opposite --- zero | Z opposite --- zero |

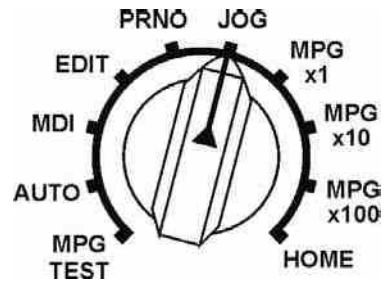

Fig.2-17

1. Press “Jog” key, and the corresponding axis will start moving:
2. Hold “Fast” key, the axis will move at maximum speed.
(If “Fast” key is not pressed, the axis displacement speed will be set in the Parameter page).
3. For document transmission, please refer to **appendi**.
4. Lubricant: Under “Manual” screen, press “F2” Key to select or cancel “Lube” function. When “Lube” indicates reverse white, it means such function is active; otherwise, it will be cancelled. (The parameter item can be used to adjust the continuous automatic lubrication time and the time interval of every two lubrication cycles.)
5. Release Spindle: Under Manual screen, press the “F3” Key to select or cancel Spindle release function. When “Release Spindle” indicates reverse white, it means such function is active; otherwise, it will be cancelled. Upon starting the “Release Spindle”, the Spindle can be turned by hand manually. (The “Release Spindle” function shall be effective for the voltage closed circuit spindle or the pulse type Spindle and the Spindle has returned to the Home Position.)
6. Spindle Positioning: After the Spindle returns to the Home Position, the Spindle position will be displayed on the manual screen. Press “F4” Key “Spindle Position” (in reverse white), the system will position the Spindle at the angle set by the user (the parameter can be used to set the positioning angle and rpm).
7. Select Spindle: Under “Manual” screen, press “F5” Key to select the active Spindle. (If the Spindle count is “1”, then it means “Spindle #1” is active; if the Spindle count is 3, press “F5” Key for shifting among Spindle #1, #2 and #3 and

the screen will display the active Spindle.)

8. Corresponding Coordinate Zero Setting: Under “Manual” screen, press “F6”, “F7” and “F8” keys and you may set the corresponding X, Y (starting status) and Z coordinates at zero.
9. Manual Switch:
 - a. Spindle: CW, CCW, Stop
 - b. Coolant: Press once for ON and press again for OFF.
 - c. Manual Chuck: Press once for releasing and press again for clamping.
 - d. Tool Change: For Hydraulic Turret and Electric Turret, press “Manual Tool Change” key and you may change to next tool along the direction set in the “Manual Tool Change Direction” parameter item.
 - e. Chip Remover: Press “Chip Remove CW” and “Chip Remove CCW”, and you may change the status of Chip Remover flexibly.
 - f. Tailstock FWD/REV: Press “Tailstock FWD” and “Tailstock REV” key, and you may control the Tailstock action manually.

□ M□□ Mode □□reen

『MODE』 switch turn to 【MPGx1】、【MPGx10】、【MPGx100】：

| | | | | | |
|-------------------------------|-----------|-----------------------------|-----------------------------------|------------------------|------------------------|
| PRNO: 000/G98/L: 0000/N: 0000 | | | 99/99 99.99 | | |
| Program coordinate | | [Error count] | Offset | | MPG x 000 |
| ● X | -0000.000 | -00000 | -0000.000 | G01 : % 000 | |
| ● Y | -0000.000 | -00000 | -0000.000 | G00 : % 000 | |
| ● Z | -0000.000 | -00000 | -0000.000 | M : 0000 | |
| ●→C | -000.000 | rpm:0000 S1: 0000 SS0%: 000 | | T : 0000 | |
| ●→A | -000.000 | rpm:0000 S2: 0000 SS0%: 000 | | Feed rate: | |
| ●→B | -000.000 | rpm:0000 S3: 0000 SS0%: 000 | | 000.000 | |
| Distance to go | | Relative | | Machine | |
| X: | -0000.000 | X: | -0000.000 | X: | -0000.000 |
| Y: | -0000.000 | Y: | -0000.000 | Y: | -0000.000 |
| Z: | -0000.000 | Z: | -0000.000 | Z: | -0000.000 |
| Current execution block: 0000 | | | Total processing time(s): 0000000 | | |
| | | | Count: 0000000 | | |
| Coolant pump error | | | | MPG | HOLD |
| SP-ZERO | SP-FREE | Spindle 1 | X opposite --- zero | Y opposite --- zero | Z opposite --- zero |

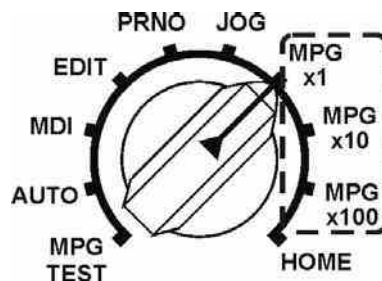

Fig.2-18

Press “Jog” key and you may select the axis (the selected axis will indicate reverse white on the screen), and then rotate the Hand Wheel to move the axis. You may also select the multiple of Hand Wheel by adjusting the knob position, such as 1x, 10x and 100x.

□ **HOM** □ **Mode** □ **Green**

The following screen displays when the “Mode Selection” knob is set to “Home”:

| | | | |
|---------------------------------------|-----------|----------------------------|---|
| PRNO: 000 / G98 / L : 0000 / N : 0000 | | | 99/99 99:99 |
| Program coordinate | | [Error count] | Offset |
| ● X | -0000.000 | -00000 | -0000.000 |
| ● Y | -0000.000 | -00000 | -0000.000 |
| ● Z | -0000.000 | -00000 | -0000.000 |
| ●→C | -000.000 | rpm:0000 S1: 0000 SS0%:000 | MPG X 000 |
| ●→A | -000.000 | rpm:0000 S2: 0000 SS0%:000 | G01 :% 000 |
| ●→B | -000.000 | rpm:0000 S3: 0000 SS0%:000 | G00 :% 000 |
| | | | M : 0000 |
| | | | T : 0000 |
| | | | Feed rate: |
| | | | 000.000 |
| Distance to go | | Relative | Machine |
| X: | -0000.000 | X: -0000.000 | X: -0000.000 |
| Y: | -0000.000 | Y: -0000.000 | Y: -0000.000 |
| Z: | -0000.000 | Z: -0000.000 | Z: -0000.000 |
| Current execution block: 0000 | | | Total processing time(s): 0000000 |
| | | | Count: 0000000 |
| Coolant pump error | | | HOME <input type="checkbox"/> HOLD <input type="checkbox"/> |
| SP-ZERO | SP-FREE | Spindle 1 | X opposite ---zero |
| | | | Y opposite ---zero |
| | | | Z opposite ---zero |

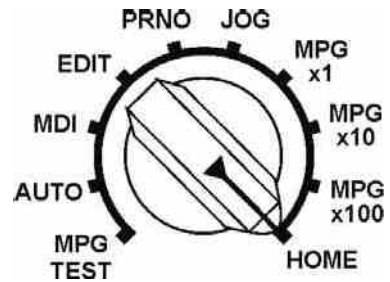

Fig. 2-19

Home Position returning operation method:

1. Press “X+” or “X-” key of the Auxiliary Panel for 0.2 second, and X Axis will execute the Home Position returning action.
2. Press “Z+” or “Z-” key of the Auxiliary Panel for 0.2 second, and Z Axis will execute the Home Position returning action.
3. Spindle Home Position:
 - (1) If the Voltage Closed Circuit Type Spindle remains inactive after pressing “F2” key, then it is not necessary to return the Spindle to Home Position or set at zero.
 - (2) In the Pulse-type Spindle or Voltage Closed Circuit Type Spindle, press the “F2” Key for setting corresponding functions according to the Parameter Page.
 - a. When setting the parameter at “Locate Home Position for Spindle signal and the Grid signal required”, the “F2” Key shall corresponds to “Spindle Home Position”. Press such key, and the Spindle will execute Home Position returning steps the same as ordinary Servo Axis (find out the Home Position Switch signal first and then Motor Grid signal).
 - b. When setting the parameter at “Locate Home Position signal for Spindle not required, but the Grid signal is required”, the “F2” Key shall correspond to “Spindle Home Position”. Press such key, and the Spindle will not find out the Spindle Home Position Switch signal but will find out the Motor Grid signal to complete the Home Position returning action.

- c. When setting the parameter at “Neither Home Position for Spindle signal not required, but the Grid signal is required”, the “F2” Key shall corresponds to “Spindle Home Position signal nor Grid signal is required”, the “F2” Key shall corresponds to “Spindle Zero Point”. Under such status, push the said function key and the current Spindle position will be set as the Home Position of the Spindle.

Input/Output Mode

Press “I/O/MCM” once to enter I/O mode. The following screen displays:



| | | |
|-------------------------|--------------------------|-------------------------------------|
| PRNO: 000 | | |
| I00 EM-stop | I16 X-axis OT+ | O00 SP1 CW |
| I01 X home | I17 X-axis OT- | O01 SP1 CCW |
| I02 Z home | I18 Z-axis OT+ | O02 Coolant |
| I03 X-axis error | I19 MPG rate x10 | O03 Lube |
| I04 Z-axis error | I20 SP1 home signal1 | O04 Lamp RED |
| I05 Spindle 1 error | I21 Chuck unclamp signal | O05 Cutter head unclamp |
| I06 External start | I22 Chuck clamp signal | O06 Cutter head CW |
| I07 External feed-hold | I23 Bar feeder reach | O07 Cutter head CCW |
| I08 Foot switch | | O08 SP1 chuck1 |
| I09 | I24 Y home | O09 Tailstock FOR |
| I10 | I25 Y-axis error | O10 Tailstock REV |
| I11 | I26 Y-axis OT+ | O11 Conveyor CW |
| I12 Tool 4 | I27 Y-axis OT- | O12 Conveyor CCW |
| I13 Tool count | | O13 Electric tool CW |
| I14 Parity check signal | | O14 Electric tool CCW |
| I15 Tool clamp signal | | O15 SP1 brake |
| 0000 | | |
| X | -0000.000 | Y -0000.000 |
| Z | -0000.000 | |
| Coolant pump error | | Ready <input type="checkbox"/> HOLD |
| Back | Main | Panel |
| | | IOCSA |

Fig. 2-20 “Input/Output” Status of the Controller

Press the “IOCSA” soft key to display the following output status screen:

| | | |
|---------------------------------------|---------------------------------|------------------------------------|
| PRNO: 000 / G98 / L : 0000 / N : 0000 | | 99/99 99.99 |
| I BIT | 0 1 2 3 4 5 6 7 8 9 A B C D E F | |
| 0000 | 0 0 0 0 0 0 0 0 0 0 0 0 0 0 0 0 | |
| 0016 | 0 0 0 0 0 0 0 0 0 0 0 0 0 0 0 0 | |
| 0032 | 0 0 0 0 0 0 0 0 0 0 0 0 0 0 0 0 | |
| 0048 | 0 0 0 0 0 0 0 0 0 0 0 0 0 0 0 0 | |
| 0064 | 0 0 0 0 0 0 0 0 0 0 0 0 0 0 0 0 | |
| 0080 | 0 0 0 0 0 0 0 0 0 0 0 0 0 0 0 0 | |
| 0096 | 0 0 0 0 0 0 0 0 0 0 0 0 0 0 0 0 | |
| 0112 | 0 0 0 0 0 0 0 0 0 0 0 0 0 0 0 0 | |
| 0128 | 0 0 0 0 0 0 0 0 0 0 0 0 0 0 0 0 | |
| 0144 | 0 0 0 0 0 0 0 0 0 0 0 0 0 0 0 0 | |
| 0160 | 0 0 0 0 0 0 0 0 0 0 0 0 0 0 0 0 | |
| 0176 | 0 0 0 0 0 0 0 0 0 0 0 0 0 0 0 0 | |
| 0192 | 0 0 0 0 0 0 0 0 0 0 0 0 0 0 0 0 | |
| 0208 | 0 0 0 0 0 0 0 0 0 0 0 0 0 0 0 0 | |
| 0224 | 0 0 0 0 0 0 0 0 0 0 0 0 0 0 0 0 | |
| 0240 | 0 0 0 0 0 0 0 0 0 0 0 0 0 0 0 0 | |
| X | -0000.000 | Y -0000.000 |
| Z | -0000.000 | |
| | | AUTO <input type="checkbox"/> HOLD |
| Back | Main | Back |

Fig. 2-21 Controller “IOCSA” Status

Press the   soft key to change the IOCSA status screen:

Press the “Panel” soft key to display the following panel status screen :

| | | | | | | |
|--------------|--------------|-------------|---------------|--------------------|--------------|-------------------------------------|
| PRNO: 000 | | | | | | |
| 0144 1144 | 0145 1145 | 0146 1146 | 0147 1147 | 0148 1148 | 0149 1149 | |
| OT-Limit | Work Lights | Tool change | Conve.-For | Conve.-Rev | Chuck OP/CLS | |
| 0150 1150 | 0151 1151 | 0152 1152 | 0153 1153 | 0154 1154 | 0155 1155 | 1184 1185 1186 1187 |
| Block delete | Single block | M01 | Tailstock Out | Tailstock Back | Coolant | MODE switch |
| 0156 1156 | 0157 1157 | 0158 1158 | 0159 1159 | 0160 1160 | 0161 1161 | 1183 |
| ↶C | X↑ | Y↗ | G01 MFO% | G00 MFO% | SSO% | G |
| 0162 1162 | 0163 1163 | 0164 1164 | 0165 1165 | 0166 1166 | 0167 1167 | 0177 1177 |
| ←Z | RAPID | Z→ | G01 MFO% | G00 MFO% | SSO% | START |
| 0168 1168 | 0169 1169 | 0170 1170 | 0171 1171 | 0172 1172 | 0173 1173 | 0176 1176 |
| ↵Y | X↓ | C↘ | SP-CW | SP-STOP | SP-CCW | FEED HOLD |
| 0000 | | | | | | |
| X | -0000.000 | Y | -0000.000 | Z | -0000.000 | |
| | | | | Coolant pump error | | Ready <input type="checkbox"/> HOLD |
| Back | Main | | | | | I/O |

Fig. 2-22 “Panel I/O” Status of the Controller

The corresponding screen does not display when this page displays and the work mode knob is turned. This function is used to check the work mode knob is correct.

Press the “I/O” soft key to display the input and output status screen.

□ **Parameter** □ **reen** □

Quickly press “IO/Parameter” key twice to enter the Parameter Mode and listed below is the relevant page:

| | | | | |
|--|--------|--------------|---|------------------|
| G71,G72 go into | X-AXIS | -00.000 inch | Z-AXIS | -00.000 inch |
| G73 amount cutting | | -00.000 inch | | -00.000 inch |
| G71,G72 retreat | | -00.000 inch | G73 segmentation | 0000 |
| G74,G75 retreat | | -00.000 inch | G76 fine cutting | 0000 |
| G76 Angle of tool tip | | 0000 | G76 chamfer Len | 0000 |
| G76 Depth of minimum cutting | | -00.000 inch | G76 retreat | -00.000 inch |
| MPG Direction $\frac{1}{2}$ $\frac{3}{4}$ $\frac{5}{8}$ $\frac{7}{8}$ $\frac{9}{16}$ $\frac{11}{16}$ $\frac{13}{16}$ $\frac{15}{16}$ | | 0 | Graphic proportion | 0000.000 |
| G84 dwell at bottom time | | 000000 | Multi-purpose MPG 1:yes | 0 |
| G84 Acc/Dec fine tuning time | | 000000 | 0:Diameter 1:Radius | 0 |
| G83 buffer distance | | 0000.000 | Chuck type 0:in 1:out | 0 |
| Chuck locked delay time | | 000000 | Metric 0:mm 1:inch | 0 |
| Wait for SP speed reaching | | 0 | Screensaver 0:yes | 0 |
| MPG-test feedrate Num. | | 0000 | Restart,skip M98 1:yes | 0 |
| MPG-test feedrate Den. | | 0000 | Non-stop 0:no 256:yes | 000 |
| Restart,MTS G04 0:skip 1:run | | 0 | TLM function 0:open 1:close | 0 |
| Restart,block refetch 0:yes | | 0 | Edit omit decimal 1:yes | 0 |
| Remaining days | | 0000000 | Lamp yellow $\frac{0}{feed-hold}$ $\frac{1}{M2/M3}$ $\frac{2}{all}$ | 0 |
| Tapping Acc/Dec time (ms) | | 0000 | Cover connection $\frac{1}{G02/G03}$ $\frac{2}{G01/G00/eng}$ | 0 |
| G41/G41 interference deal with 0/1/2 | | 0 | Use Y axis 1:yes | 0 |
| Coolant pump error | | | | |
| Back | Main | | SYSTEM MCM | VERSION G54..G59 |

Fig.2-23

G54 ~ G59 Working Coordinates Setting:

Press “G54..G59” Key to enter the working coordinates system setting screen.

| G54 ~ G59 Workpiece coordinate system | | | |
|---------------------------------------|-------------|----------------|-----------------------------------|
| Machine pos. | | Workpiece pos. | |
| X | -0000.000 | | -0000.000 |
| Y | -0000.000 | | -0000.000 |
| Z | -0000.000 | | -0000.000 |
| | X-AXIS | Y-AXIS | Z-AXIS |
| G54 | : -0000.000 | -0000.000 | -0000.000 |
| G55 | : -0000.000 | -0000.000 | -0000.000 |
| G56 | : -0000.000 | -0000.000 | -0000.000 |
| G57 | : -0000.000 | -0000.000 | -0000.000 |
| G58 | : -0000.000 | -0000.000 | -0000.000 |
| G59 | : -0000.000 | -0000.000 | -0000.000 |
| 99/99 99:99 | | | |
| X | -0000.000 | Y | -0000.000 |
| Z | -0000.000 | | |
| | | | MDI <input type="checkbox"/> HOLD |
| Back | Main | SAVE-X | SAVE-Y |
| | | SAVE-Z | BACK |

Fig.2-24

□ Software Version Screen

Press the “Software Version” soft key on the second page of the parameter screen to display the version screen:

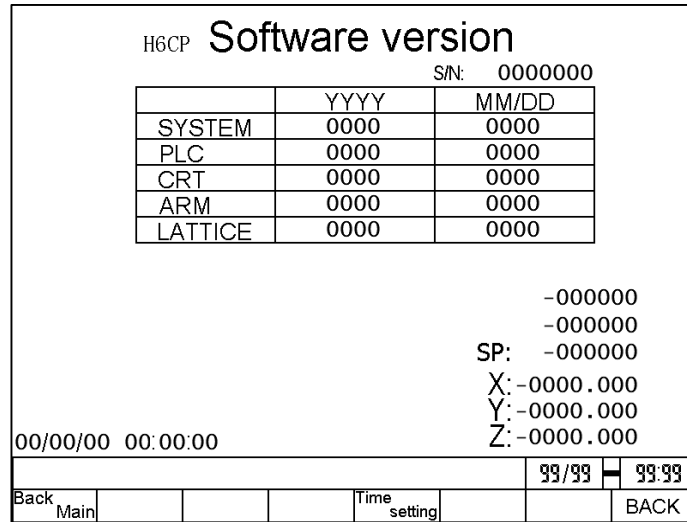

Fig. 2-25

1. Shown in the screen are system time, PLC time, screen time, ARM time and Lattice time.

Example: System 2010 627
 PLC 2010 623

System Time: June 27, 2010
 PLC Time: June 23, 2010

2. Time Setting: Press “Time Set” key (indicating reverse white) and then press ← → key for showing year, month, day, hour, minute and second, edit the value and then press “Time Set” again. When the screen displays “Data Loading OK” wording, it means the time has been successfully set.

Note □ □ h function shall □ e set □ □ use □ ith □ orrespondin □ per □ ission □

□ □ste□ □ara□eter □reen

Press the “System Parameter” soft key on the second page of the parameter screen to display the system parameter page.

| PARAMETERS | X-AXIS | Y-AXIS | Z-AXIS |
|---|-----------|-----------|-----------|
| Resolution-Den.(pulse) | 0000000 | 0000000 | 0000000 |
| Resolution-Num.(pitch) | 0000000 | 0000000 | 0000000 |
| Traverse speed | 0000000 | 0000000 | 0000000 |
| Rotate direction | 0 | 0 | 0 |
| Home speed-1 | 0000000 | 0000000 | 0000000 |
| Home speed-2 | 0000000 | 0000000 | 0000000 |
| Home direction | 0 | 0 | 0 |
| Find grid direction | 000 | 000 | 000 |
| Distance of grid error | -0000.000 | -0000.000 | -0000.000 |
| Software OT(+) | -0000.000 | -0000.000 | -0000.000 |
| Software OT(-) | -0000.000 | -0000.000 | -0000.000 |
| MPG Den. | 0000000 | 0000000 | 0000000 |
| MPG Num. | 0000000 | 0000000 | 0000000 |
| Pitch err comp.(-1,0,1) | -0 | -0 | -0 |
| Pitch err segment length | 0000.000 | 0000.000 | 0000.000 |
| Backlash(G01) | 00.000 | 00.000 | 00.000 |
| Pulse cmd width ^{2500K} _W | 0 | 0 | 0 |
| Grid offset | -000.000 | -000.000 | -000.000 |

Coolant pump error

| | | | | | | | |
|------|-----------------|--|--|---------|-------------|------------|------|
| Back | Change password | | | ALL MCM | Pitch Error | MCM Modify | PAGE |
|------|-----------------|--|--|---------|-------------|------------|------|

Fig. 2-26

- The Advanced Parameter modification is protected by password → Default Value = 123456.
- To modify the Advanced Parameter, press “Modify Parameter” key and it will skip to Password Input Page as per Fig. 2-26.
- After entering correct Advanced Parameter password, the user shall be allowed to modify the Advanced Parameter.
- After entering the system parameter page, press “Change Password” key and it will skip to the password change page. Enter current password and new password according to the hint shown in the screen, as per Fig. 2-27.

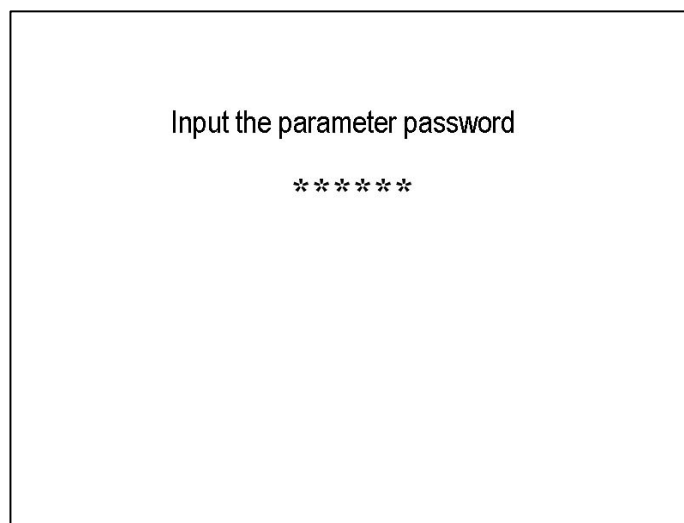

Fig. 2-27

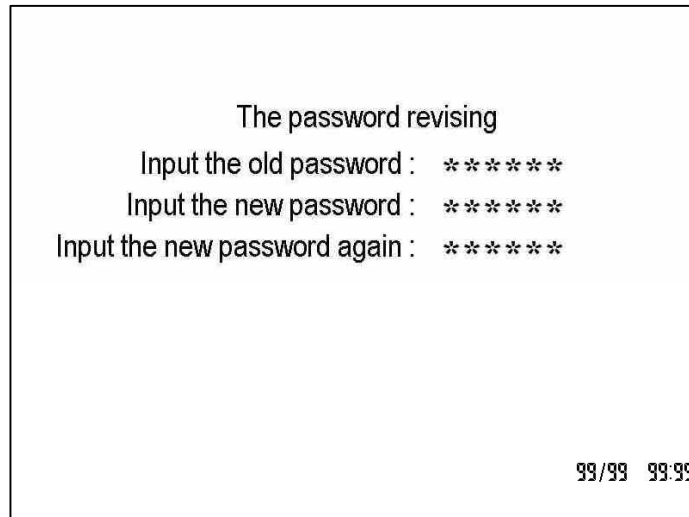

Fig. 2-28

Note: After entering the correct Advanced Parameter password and before restarting, you may change the system parameter setting screen directly during the next operation (password not required).

□ Tool □adius

Press the 「Tool Radius」 key into this page.

□rere□uisite: The axis must in the **Home position** that can into this page.

Page (1) :

| Please input the Dimensions of the Work- Piece | | | | | | | |
|--|-------|-----------|------------|------------|------------|-----------------|-----------------|
| | | NO. | 00 | 99/99 | 99.99 | | |
| | | ∅ | -0000.000 | | | | |
| | | L | -0000.000 | | | | |
| | | H | -0000.000 | | | | |
| **If tool locate at the "Dir-" of center line Please use "-" diameter ∅ | | | | | | | |
| < Opposite > | X: | -0000.000 | Y: | -0000.000 | Z: | -0000.000 | |
| < Machine > | X: | -0000.000 | Y: | -0000.000 | Z: | -0000.000 | |
| MPG X | 000 | SP rpm : | 00000 | | | X: | -0000.000 |
| G01 : | % 000 | Spindle : | X | SAVE | NO. | Y: | -0000.000 |
| G00 : | % 000 | A: | -000.00 | ⇒ | 00 | Z: | -0000.000 |
| SSO : | % 000 | B: | -000.00 | | | | |
| | | C: | -000.00 | | | | |
| Back | Main | SP-ZERO | X-T-Offset | Y-T-Offset | Z-T-Offset | X opposite zero | Y opposite zero |
| | | | | | | Z opposite zero | |

Fig. 2-29

Note□When mount the Tool above the Workpiece, it means the Upper Holder (Rear Holder); when mounting under the Workpiece, it means the Lower Holder (Front Holder). The system parameters can be used to set the Holder type, for example, X-Axis means the direction when Tool is leaving the Workpiece (refer to Fig. 2-34). If the Tool is located at “Negative X Direction” at the center of the Workpiece, then negative value should be entered for the diameter (as per Example 2).

Tool Cali□ration □tep□

1. Clamp the Workpiece securely (clamp with Pedal Switch or Manual Chuck key).
2. Set the group number.
3. Write in X-Axis position.
 - a. Move the Tool with Hand Wheel for accepting OD machining. Before the entire Tool leaves the machining coordinates, press the “X Tool Offset” key and at this time, the system will save the machine coordinates of X-Axis in the X-Axis position.
 - b. Move the Tool away with Hand Wheel. After measuring the actual Workpiece diameter, enter the diameter of X-Axis.

- c. Press “X Tool Offset” key again and the Controller will calculate automatically for writing the result in the designated Tool length offset parameter.
4. Write in Z-Axis Position:
 - a. Move the Tool with the Hand Wheel for accepting end face machining. Before the entire Tool leaves the machining coordinates, press “Z Tool Offset” key and at this time, the system will save the machine coordinates of X-Axis in the Z-Axis position.
 - b. Enter the Workpiece length. To use the machining end face as the working Home Position for Z-Axis, set the length as “0”.
 - c. Press “Z Tool Offset” key again and the Controller will calculate automatically for writing the result in the designated **Tool length offset** parameter.

□□a□ple 1□

1. If the Tool has not entirely left the machining coordinates, the machine coordinates will be (13.000, 13.638.)
2. Enter diameter as 20.000mm (diameter program setting and the Tool is located at the X position direction at the centerline of the Workpiece).
3. Enter the length as 0.000mm (the machining end face will be the working Home Position of Z-Axis).
4. Press “F4-X Tool Offset” and “F5-Z Tool Offset” respectively.
5. The X, Z coordinates saved for the Tool setting screen will be (6.000 and 13.638) respectively. Under Tool length offset screen, the X, Z coordinates of this group will be (6.000, 13.638.)

□□a□ple 2□

1. If the Tool has not entirely left the machining coordinates, the machine coordinates will be (-15.400, 12.166.)
2. Enter diameter as -20.000mm (radius program design and the Tool is located at X negative direction at the centerline of the Workpiece).
3. Enter the length as 10.000mm (the machining end face will be the working Home Position of Z-Axis).
4. Press “F3-X Tool Offset” and “F5-Z Tool Offset” respectively.

The X, Z coordinates saved for the Tool setting screen will be (-5.400 and 2.166) respectively. Under Tool length offset screen, the X, Z coordinates of this group will be (-5.400, 2.166.)

□ Tool Compensation Screen

Click the “T.Radius / T.Offset” once to enter tool compensation mode. The following screen displays:

| Max: 0.000 | | Tool Wear Compensation | | | Incremental | |
|------------|-----------|------------------------|-------------|-------------|-------------|------|
| NO. | X-AXIS | Z-AXIS | Tool-Radius | | | |
| 00 | -0000.000 | -0000.000 | -000.000 | | | |
| 00 | -0000.000 | -0000.000 | -000.000 | | | |
| 00 | -0000.000 | -0000.000 | -000.000 | | | |
| 00 | -0000.000 | -0000.000 | -000.000 | | | |
| 00 | -0000.000 | -0000.000 | -000.000 | | | |
| 00 | -0000.000 | -0000.000 | -000.000 | | | |
| 00 | -0000.000 | -0000.000 | -000.000 | | | |
| 00 | -0000.000 | -0000.000 | -000.000 | | | |
| 00 | -0000.000 | -0000.000 | -000.000 | | | |
| X | -0000.000 | | Z | -0000.000 | | |
| | | | | | MDI | HOLD |
| Main Page | WEAR | OFFSET | Absolute | Incremental | G54.G59 | |

Fig. 2-30

In this mode, it is possible to switch between two screens. Press the “soft key” to cycle between tool-wear compensation, tool-length compensation, and parameter screens.



The tool length compensation screen is shown as follows:

| | | Tool Offset Compensation | | | Incremental | |
|-----------|-----------|--------------------------|-------------|-----------|-------------|---------|
| NO. | X-AXIS | Z-AXIS | Tool-Radius | T-Dir | | |
| 00 | -0000.000 | -0000.000 | -000.000 | 0 | | |
| 00 | -0000.000 | -0000.000 | -000.000 | 0 | | |
| 00 | -0000.000 | -0000.000 | -000.000 | 0 | | |
| 00 | -0000.000 | -0000.000 | -000.000 | 0 | | |
| 00 | -0000.000 | -0000.000 | -000.000 | 0 | | |
| 00 | -0000.000 | -0000.000 | -000.000 | 0 | | |
| 00 | -0000.000 | -0000.000 | -000.000 | 0 | | |
| 00 | -0000.000 | -0000.000 | -000.000 | 0 | | |
| X | -0000.000 | | Z | -0000.000 | | |
| | | | | | MDI | HOLD |
| Main Page | WEAR | OFFSET | T-M-Input | Absolute | Incremental | G54.G59 |

Fig. 2-31

There are 40 groups respectively for tool-wear compensation and tool-length compensation.

1. Set Tool Wearing Offset and Tool Length Offset according to the following method:

- a. Confirm the input type of Tool Wearing Offset and Tool Length Offset (absolute value/increment value will be hinted at the upper right corner, and it is not required to enter X/Y/Z, U/V/W), and then press lower soft key to switch the input method. With “Cursor”   key, move the cursor to the parameter to be changed.

 - b. After entering the value key, press “Enter” key.
 “Measuring”: The Hint text will appear **after returnin□ the □□is to Ho□e □osition of the □a□hine**. Press this key and it will indicate reverse white and flicker. Move the Tool with Hand Wheel for accepting the OD and end face machining. Before the entire Tool leaves the machining coordinates, move the cursor to the group to be entered (under Tool length offset screen) for entering the corresponding diameter value (X-Axis) or length diameter (Z-Axis) and then the system will set the Tool length offset value automatically.
2. Change Tool offset value during operation:
 - a. Lock by increment setting method (without affecting the input type not being executed).
 - b. In the system parameters, set under the “Input max. wearing value during operation” (default value: 2.000; max. value: 2.000mm).

 3. Max. Wearing Offset Set Value: In the system parameters, set under the “Max. Wearing Offset Value” (default value: 2.000; max. value: 20.000 mm), and the set parameter value will be shown at the upper left corner of the Wearing Offset screen.

□ □ □□□□ □□□□ or □ □ordinate settin□ pa□e

| G54 ~ G59 Workpiece coordinate system | | | | | | |
|---------------------------------------|-----------|----------------|-----------|-----------|-------------------------------|------|
| Machine pos. | | Workpiece pos. | | | | |
| X | -0000.000 | -0000.000 | | | | |
| Y | -0000.000 | -0000.000 | | | | |
| Z | -0000.000 | -0000.000 | | | | |
| | | X-AXIS | Y-AXIS | Z-AXIS | | |
| G54 : | -0000.000 | -0000.000 | -0000.000 | -0000.000 | | |
| G55 : | -0000.000 | -0000.000 | -0000.000 | -0000.000 | | |
| G56 : | -0000.000 | -0000.000 | -0000.000 | -0000.000 | | |
| G57 : | -0000.000 | -0000.000 | -0000.000 | -0000.000 | | |
| G58 : | -0000.000 | -0000.000 | -0000.000 | -0000.000 | | |
| G59 : | -0000.000 | -0000.000 | -0000.000 | -0000.000 | | |
| | | | | 99/99 | 99:99 | |
| X | -0000.000 | Y | -0000.000 | Z | -0000.000 | |
| | | | | MDI | <input type="checkbox"/> HOLD | |
| Back | Main | | SAVE-X | SAVE-Y | SAVE-Z | BACK |

Fig. 2-26

Input method:

1. Used the cursor key to move input position and input the values then press the 『Enter』 key.
2. Used the cursor key to move input position then used MPG or JOG key move the axis to the target position, press faster the **【SAVE-X】**、**【SAVE-Z】** or **【SAVE-A】** key twice (0.5 Sec.), the values will be renew from up-left **【MACHINE-POSITION】** .

□ □error □essa□e □

When any error message happen that system will change to this page automatically.
 (Please reference the explanation of chapter six.)

| code | Causes | code | Causes | code | Causes |
|------|------------------------------|------|---------------------------------|-------|---------------------------------|
| 01 | MCM Data Error | 13 | G/M/T code & R error | 32 | G76/G92 E,P command error |
| 02 | Follow error > setting value | 14 | Axis over-travel | 36 | Data to be transferred in error |
| 04 | USB/SDC error | 15 | Search GRID,distance exceed | 37 | NC alarm(Outside device error) |
| 05 | System error | 18 | End of program error | 38 | Screen reading time > 3 s |
| 07 | Flash rom "write to" error | 20 | Axis reached the software limit | 39 | Tool life reaching |
| 08 | MDI command error | 22 | Em-Stop | 50 | User defined error (G65) |
| 09 | G31 signal read error | 25 | G02/G03 command error | 53(1) | Tapping retract position error |
| 10 | RS232 error | 28 | G71-G73 command error | 53(2) | Tapping depth < 0 |
| 11 | Program CHECKSUM error | 29 | G code A,R,C error | 54 | Tapping F (pitch) not defined |
| 12 | Pro. burning >128k | 31 | None PLC | 55 | Tapping depth not defined |

| | | | |
|--|-------------------------------------|----------------------|------------------------|
| Spindle | Spindle 1 error | Spindle 2 error | Spindle 3 error |
| | Spindle 1 unclamp | Spindle is running | Chuck unclamp |
| Coolant pump error | | | |
| Please press SP "cw" or "ccw", before feed-hold cancel | | | |
| Feeder | Feeder doesn't meet the positioning | | |
| Other | Turret loose | Tool change time out | Count limit is reached |
| | EM-stop | Hydraulic pump error | Security door error |
| | X-axis motor error | Y-axis motor error | Z-axis motor error |

| | | |
|------|-------|------------|
| 00 | 99/99 | 99:99 |
| Back | Main | Error-LIST |

Fig. 2-27

□ □raph Mode □□reen

The following screen displays when the “MODE” switch to “Graph”.

2.2 Program Condition

2.2.1 Program Operation

2.2.1.1 Part Programs

Prior to part machining, the part shape and machining conditions must be converted to a program. This program is called a part program. A comprehensive machining plan is required for writing the part program. The following factors must be taken into account when developing the machining plan:

1. Determine the machining range requirements and select a suitable machine.
2. Determine the work-piece loading method and select the appropriate tools and chucks.
3. Determine the machining sequence and tool path.
4. Determine the machining conditions, such as the spindle speed (S), feed rate (F), coolant, etc.

A part program is a group of sequential commands formulated according to a part diagram, machining plan, and command code of the numerical control unit. It is used to plan the tool path with the assistance of the auxiliary functions of the machine. The part program can be transmitted to the memory of the control unit via a PC, punched paper tape, or keyboard.

2.2.1.2 Program Methods

A numerical control unit executes actions exactly in accordance with the commands of the part program. So, programming is very important for numerical control machining. There are two ways to design a CNC part program and they are briefly described in the following:

1. Good capability of reading part diagrams.
2. Rich experience in machining processes.
3. Familiar with the functionality, operation procedure and programming language of the machine.
4. Basic capability in geometric, trigonometric, and algebraic operations.
5. Good capability of determination of machining conditions.
6. Good capability in setting chucks.
7. Good capability in determination of part material.

Two programming methods are available for the part program of the numerical control unit:

- Manual Programming
- Automatic Programming

Manual Programming

All processes from drawing of the part diagram, machining design, numerically controlled program algorithm, programming, to the transmission of the program and the controller are performed manually.

The coordinates and movements of the tool used in machining operations should be first calculated during the manual programming process. Calculation will be easier if the part shape is comprised of straight lines or 90-degree angles. For curve cutting, however, the calculation is more complicated. Both geometric and trigonometric operations are required for accurate curves. After acquiring the coordinates of the work-piece, create a complete numerically controlled part program in a specified format using the movement command, movement rate, and auxiliary functions. Check the program and make sure that there are no errors before transmitting it to the controller.

Automatic Programming

All processes from drawing the part diagram to transmitting the part program are performed with a PC.

For complex part shapes, it is both time-consuming and error-prone to calculate the coordinate values manually, resulting in nonconforming-machined products. To make use of the high-speed capabilities of the computer, the programmer designs a simple part program to describe the machine actions and the shape, size, and cutting sequence of the part, reinforcing the communication and processing capability of the computer. The input data is translated into a CNC program using a PC, which is in turn transmitted to the CNC controller via the RS232C interface. This is called the CAD/CAM system and is used by many units using CNC machines to create a program especially machining a 3-D work-piece.

2.2.1 Program Composition

A complete program contains a group of blocks. A block has a serial number and several commands. Each command is composed of a command code (letters A~Z) and numeric values (+, -, 0~9). An example of a complete part program containing 10 blocks is shown in the table below. A complete program is assigned with a program number, such as O001, for identification.

A complete program:

```

N10 G0 X40.000 Z10.000
N20 G00 X30.000 Z5.000
N30 M3 S3000
N40 G1 X10.000 F200
N50 W-5.000
N60 X15.000 Z-10.000
N70 X30.000 W-10.000
N80 G0 X40.000 Z10.000
N90 M5
N100 M2

```

Block is the basic unit of a program. A block contains one or more commands. No blank should be inserted between commands when transmitting a program. A block has the following basic format:

N- ___ G ___ X(U) ___ Z(W) ___ F ___ S ___ T ___ M ___

N : Block Sequence Number
G : Function Command
X, Z : Coordinate positioning command (absolute movement command).
U, W : Coordinate positioning command (incremental movement command).
F : Feed rate.
S : Spindle speed.
T : Tool command.
M : Auxiliary functions (machine control code).

Except for the block serial number (N), the command group of a block can be classified into four parts:

1. **Function Code and** The G-code, for example, is used to instruct the machine to perform actions, such as linear cutting, arc cutting, or thread cutting.
2. **Positioning Code and** X, Z, U, W commands, for example, instructs the G-code of the machine to stop at a specified position; i.e. destination or end point of the action.
3. **Feed Rate Code and** This command instructs the tool to cut (G-code) at a specified speed.
4. **Auxiliary Function** The M, S, T, L commands, for example, determine the start, stop, spindle speed, tool selection, and execution times of the machine.

However, not every block contains these four commands. Some blocks have only one command. This will be further discussed in Chapter III.

Except for the block serial number of the block N___, all other components of the basic block format are commands. A command contains a command code (letter), a +/- sign, and some numbers.

Basic Command Format (e.g. the positioning command):

```
X-10.000
X          : Command code
"-        : +/- sign (+ can be omitted)
10.000    : Destination of a tool positioning action.
```

The command codes include the function command code, positioning (or coordinate) command code, feed-rate command code, and auxiliary function command code. Each command code has its own definition and the machine behaves according to the command code given. The command codes of H6D-T Series and their definitions are described below.

```
F:      Feed-per-rotation command. mm/rev or mm/min
G:      Function code
I:      The X-axis component of the arc radius.
K:      The Z-axis component of the arc radius.
L:      Repetition counters.
M:      Machine control code.
N:      Program serial number.
P:      Call subprogram code; parameter in canned cycles; tool number for tool
        compensation.
Q:      Parameter in canned cycles.
```

- R: Arc radius or parameter in canned cycles.
- S: Spindle speed.
- T: Tool command.
- U: Incremental positioning command on X-axis.
- W: Incremental coordinates on Z-axis.
- X: Absolute positioning command on X-axis.
- Z: Absolute positioning command on Z-axis.
- C: Chamfer by line method between Program Node and respective Node.
- R: Chamfer by round arc method between Program Node and respective Node.
- A: Chamfer by combined line and angle method between Program Node and respective Node.

Each block has a specified format and this format must be used during programming. Incorrect formatting can result in code rejection or major errors.

Each block has a serial number for identification. Though the serial number is not essential, it is recommended to use it for easy search. The serial number contains the letter “N” followed by some digits. The number can be generated automatically or manually typed from the keyboard when editing the program. (Refer to Chapter IV). The line number order is not followed, but line numbers must be unique. The program runs in order of blocks from top to bottom rather than their serial numbers. For example:

Ex: N10.....(1) program execution order
 N30.....(2)
 N20.....(3)
 N50.....(4)

2.2.1 Coordinate System

Fabrication of a work-piece with a lathe is accomplished by the rotation of the spindle and cutting motion of the tool mounted on the machine. The tool can move in an arc or straight line. A coordinate system is used to describe the geometrical position of the intersecting point and end point of an arc or line. The cutting action is done by the controlled change of these geometrical positions (positioning control).

Coordinate Systems

The H6D-T Series uses the well-known 2-D Cartesian coordinate system. The two axes used in the lathe series are defined as X-axis and Z-axis. The Z-axis is the centerline of the lathe spindle. The intersection of the two axes is the zero point, i.e. X=0 and Z=0.

Fig. 2-28 shows the relationship among each axis, tool motions, and rotation direction of a work-piece. This manual uses the rear tool post as an example.

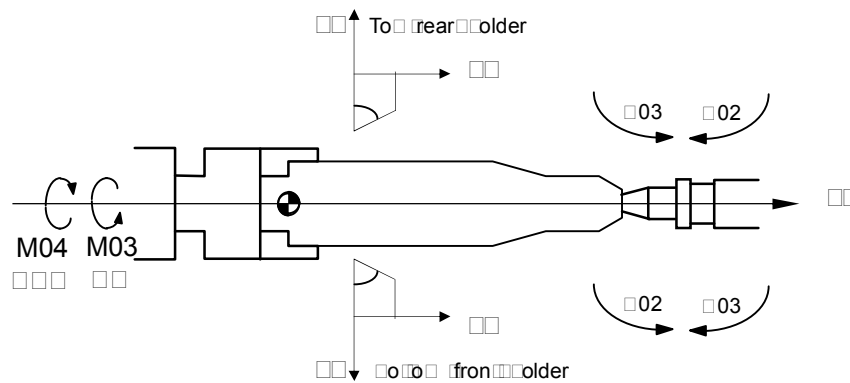

Fig. 2-28

When the spindle is rotating, your thumb points to the positive direction of the Z-axis and four fingers point to the direction of normal rotation.

Coordinate Positioning Control

The coordinate of the H6D-T Series is either absolute or incremental, depending on the command code of the coordinate axis, i.e.:

- X, Z: Absolute coordinate commands.
- U, W: Incremental (or decremental) coordinate commands.

Please note the diameter is generally used to represent the X-axis coordinate for a lathe, regardless of incremental or absolute coordinates.

Absolute Coordinate Commands

Tool-positioning coordinates are acquired with reference to the origin (work origin or program origin) of the work coordinate system. Coordinates are either positive (+) or negative (-), depending on its position relative to the origin.

Incremental Coordinate Commands

The previous coordinates of the tool are the reference point for calculating the coordinate value of the next position. The incremental coordinate is either positive (+) or negative (-). The negative sign represents decrement. Facing toward the direction of movement, if the tool is heading towards the positive (+) direction, U, W represents an increment. If it is heading to the negative (-) direction, U, W represents decrement.

X, Z and U, W are interchangeable in the program. The commands used for absolute and incremental coordinates are described as follows:

Absolute Commands: (Fig. 2-29)

```
P0 to P1 G01 X10.000 F0.200
P0 to P2 X24.000 Z30.000
P2 to P3 X32.000 Z10.000
P3 to P4 Z0.000
```

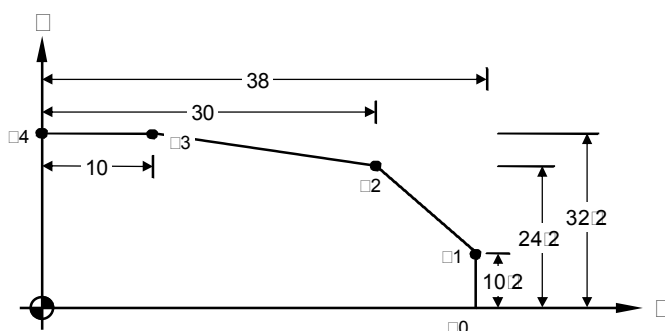

Fig. 2-29

Incremental Commands: (Fig. 2-30)

```
P0 to P1 G01 U10.000 F0.200
P1 to P2 U14.000 W-8.000
P2 to P3 U8.000 W-20.000
P3 to P4 W-10.000
```

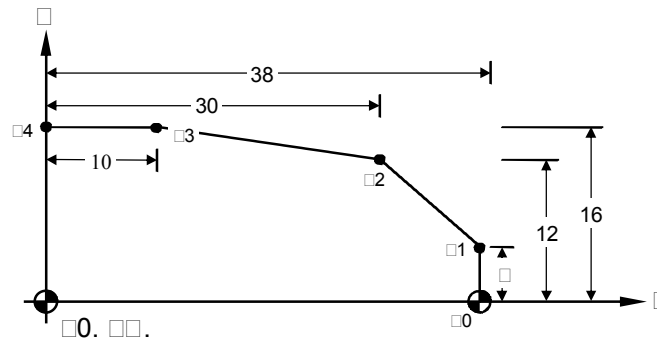

Fig. 2-30 Incremental Commands

Coordinate Interchange

```
P0 to P1 G01 X10.000 F0.200
P1 to P2 X24.000 W-8.000
P2 to P3 U8.000 Z10.000
P3 to P4 W-10.000
```

or

```
P0 to P1 G01 X10.000 F0.200
P1 to P2 U14.000 Z30.000
P2 to P3 X32.000 W-20.000
P3 to P4 Z0.000
```

Simultaneous use of absolute and incremental coordinate systems in a part program is possible. For the absolute coordinate system, the input error of the previous position, if any, does not affect the coordinates of the next point. For the incremental coordinate system, however, all subsequent positioning is affected if the previous position is incorrect. Therefore, particular attention should be paid when the incremental coordinate system is used.

There aren't any rules about when to use the incremental or absolute coordinate system. It depends on machining requirements. If each machining point is positioned relative to the home position, it is recommended to use the absolute coordinate system.

For diagonal (simultaneous positioning on the X and Z-axis) or arc movements, the coordinate value of each axis acquired from trigonometric operations will be rounded off. In this case, particular attention should be paid when the incremental coordinate system is used, as machining points may increase, and the more points there are, the greater the risk of error. Basically, whether an absolute or incremental coordinate is used

depends on the programming requirements and the specifications of the machining diagram.

Work Origin

The specifications of the machining diagram are converted to the coordinate system at the CNC lathe programming stage. Before the conversion, a point on the work-piece is selected as the zero point of the coordinate system (i.e. work origin) and the coordinates of other points on the work-piece are calculated based on this work origin.

The programmer determines the position of the work origin. It can be any point on the centerline of the spindle. However, it is recommended to select an origin that makes reading of the work-piece coordinate easier. The X-axis of the work origin should be on the centerline of the lathe spindle. One of the following three points can be selected as the work origin of the Z-axis: (Fig 2-31)

1. Left end of the work-piece.
2. Right end of the work-piece.
3. Front of the claw or chuck.

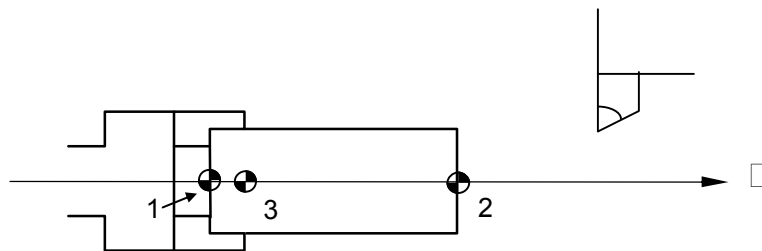

Fig. 2-31 Work Origin Selection (1, 2, or 3)

The work origin is also called work zero point or program origin program zero point. In this manual, this zero point is always referred to as the work origin. The coordinate system based on the origin is called work coordinate system. The work coordinate origin is the work origin. Referring to section 3.12 for the G10 and G50 work origin setting.

The work-piece after being cut with a CNC lathe is symmetrical. Perform machining of half the side of the work-piece. Therefore, only half of the work-piece should be drawn on the work-piece diagram when creating a program, as shown in Fig 2-32.

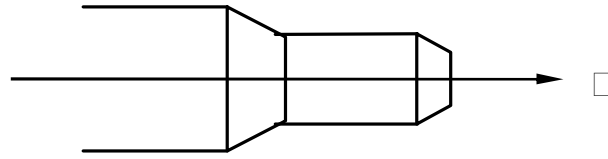

Fig. 2-32 Work-Piece Symmetrical Diagram

□ Machine Origin

There is a fixed point on the machine bed or bed rail. This point is used as a reference point for determination of the work coordinate (or work origin) and calibration of the tool length compensation. This reference point is called the machine origin.

For the H6D-T Series controller, the machine origin is the stop position of the tool when the homing for each axis is complete. As Fig. 2-31 shows, the machine origin corresponding to the coordinate used to indicate the work origin varies depending on the position of the work origin. In general, the machine origin is determined based on the position where the positioning measurement device and the touch plate of the limit switch are installed on the machine. In this case, use the positioning measurement function of the controller to obtain the relationship between this position and the coordinate used for the work origin.

The homing action should be performed after powering on the machine. If the current position is lost due to power failure, the homing action should be performed again.

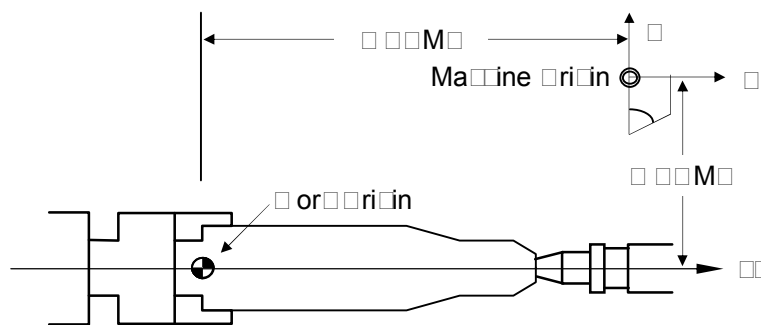

Fig. 2-33 Lathe Origin Diagram

2.2.1 Numerical Control Range

The numerical and functional control range of the H6D-T controller is described in the following two tables.

| | |
|-------------------|-------------|
| Min. setting unit | 0.001 mm |
| Max. setting unit | 9999.999 mm |
| Min. moving unit | 0.001 mm |
| Max. moving unit | 9999.999 mm |
| Max. stroke | 9999.999 mm |

| | |
|-------------------------|---|
| G-code | G00~G99 (G01=G1) |
| M-code | M000~M999 (M01=M1) |
| S-code | S1~S9999 rpm |
| F-code | 0.001~0~9999.999 mm/spin |
| X, Z, U, W, I, K | 0.001~+/-9999.999 mm |
| R (Radius) | 0.001~+/-9999.999 mm |
| G04 | 0 ~ 9999.999 seconds |
| Program number | 0 ~ 600 |
| T-code | <ol style="list-style-type: none"> 1. There are two digits after T when no turret is mounted; select a tool compensation number. 2. There are four digits after a turret is mounted; the first two digits is the tool selection and the last two digits is compensation number. |
| Memory capacity | 512 K |
| Lead screw compensation | 0~255 pulses (related to tool resolution) |
| Max. Response Speed | 500 KPPS |

The numerical control range varies depending on the specifications of the numerical control unit. Refer to the operator's manual of the machine for more information.

2.2.2 Program Editing

The program editing operation includes:

1. Program selection,
2. New program editing, and
3. Existing program change.

2.2.2.1 New Program Editing

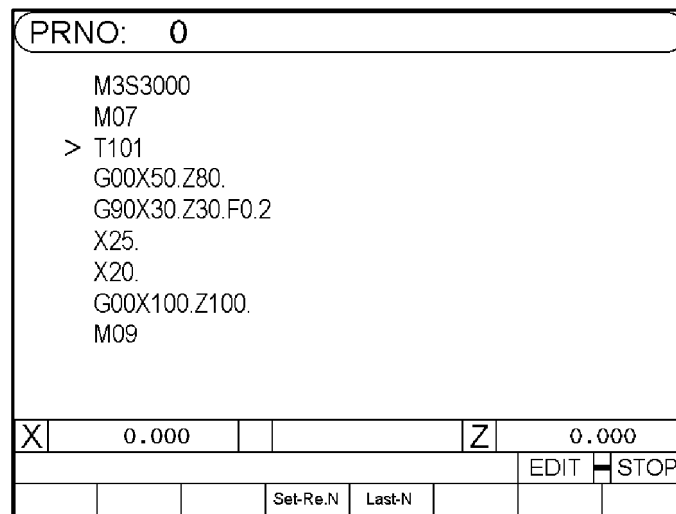

Fig. 2-39

The following keys are used to edit programs:

1. Command keys.
2. Numerical keys 0 ~ 9
3. Cursors – Use \uparrow or \downarrow to move the cursor to the block to edit.
4. Used the \uparrow or \downarrow key to switch to the pervious or next page of the program.
5. Edit one node at a time (e.g. G90 X30.Z30 F0.2) and then enter.

6. Use the Insert key to create or insert a new block.

Enter a new block in a new program or insert a new block in an existing program.

Press the Insert key after entering a new block.

7. Use the Enter key to apply/save the new changes.

Use the Enter key after adding a command or changing a command value in an existing block.

8. Use the

| |
|--------|
| Delete |
|--------|

 key to delete a program block.

Creating a Program Example:

Program 1
 N1 G0 X0.Z0.
 N2 G4 X1.
 N3 G0 U480.W-480.
 N4 G4 X1.
 N5 M99

Procedure and Description

1. Confirm that the Controller has entered the program editing status.
2. Edit and input the node:

| | | | | | | | | | |
|---|---|---|---|---|---|---|---|-----|------|
| G | 0 | X | 0 | . | Z | 0 | . | N□□ | L□N□ |
|---|---|---|---|---|---|---|---|-----|------|

| | | | | | | |
|---|---|---|---|---|-----|------|
| G | 4 | X | 1 | . | N□□ | L□N□ |
|---|---|---|---|---|-----|------|

| | | | | | | | | | | | | | | | | |
|---|---|---|---|---|---|---|---|---|---|---|---|---|----|---|------|---|
| G | 0 | U | 4 | 8 | 0 | . | W | - | 4 | 8 | 0 | . | N□ | □ | L□N□ | □ |
|---|---|---|---|---|---|---|---|---|---|---|---|---|----|---|------|---|

| | | | | | | |
|---|---|---|---|---|-----|------|
| G | 4 | X | 1 | . | N□□ | L□N□ |
|---|---|---|---|---|-----|------|

| | | | | |
|---|---|---|-----|------|
| M | 9 | 9 | N□□ | L□N□ |
|---|---|---|-----|------|

If the program is longer than one page after completing the edition, use the Page Up ↑ and Page Down ↓ to check if the programs in both pages are correct.

2.2.2.2 Editing a Program

We have created PROGRAM 1 in the previous section. The existing program change is described in this section. Changing a program includes the following procedure:

Add or Change a Comment

Ex: The third block program N3 U480. W-480.
 Changed to N3 U480. W-480. F0.2

Procedure:

1. Make sure the system is in “EDIT” mode.
2. Use ↑/↓ to move to the cursor to block N3.
3. Enter a command code and value to be added (changed), e.g. F0.2.

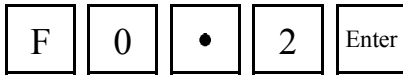

The screen shows as Fig. 2-40.

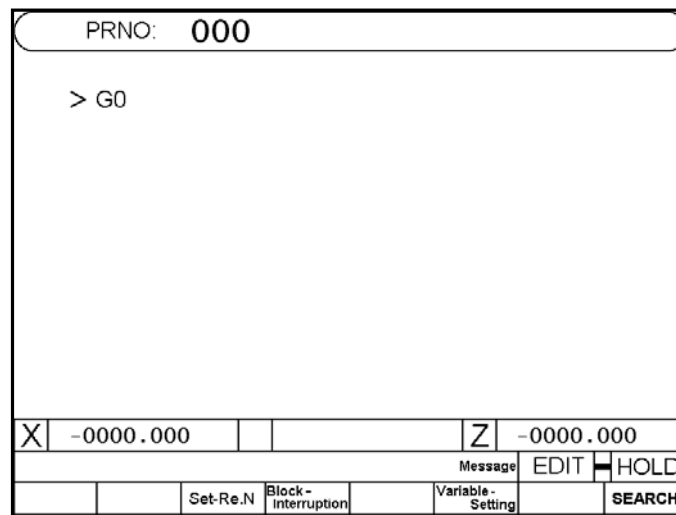

Fig. 2-40

1. Change U480. by entering U360;

To change an incorrect command, enter the correct command and press

Delete a Co□□and

Ex: The third block program N30 U480. W-480. F0.2
 Changed to N30 U480.W-480.

Procedure:

1. Make sure the system is in “EDIT” mode.
 2. Use the / key to move the cursor to block N3.
 3. Enter a command to be deleted without values, e.g;
- (No value is entered behind F). The screen shows as Fig. 2-41:

| | | | | | |
|---|-----------|----------|------------------------|----------------------|-----------|
| PRNO: 000 | | | | | |
| N1 X0. Z0. N2 G4 X1. > N3 U480. W-480.F0.2 N4 G4 X1. N5 M99 | | | | | |
| X | -0000.000 | | | Z | -0000.000 |
| | | | | Message | EDIT |
| | | | | | HOLD |
| | | Set-Re.N | Block- Interruption | Variable- Setting | SEARCH |

Fig. 2-41

Insert a block

Ex: Insert the block N31 U20. W-20 between the third block N3 G0 U480. W-480 and between N4 G4 X1

Procedure:

1. Make sure the system is in "EDIT" mode.
2. Use the / to move the cursor to block N3.
3. Enter

| | | | | | |
|---|---|---|--------|-------|-------|
| N | 3 | 1 | Insert | | |
| U | 2 | 0 | • | Enter | |
| W | - | 2 | 0 | • | Enter |

The screen shows as Fig. 2-42.

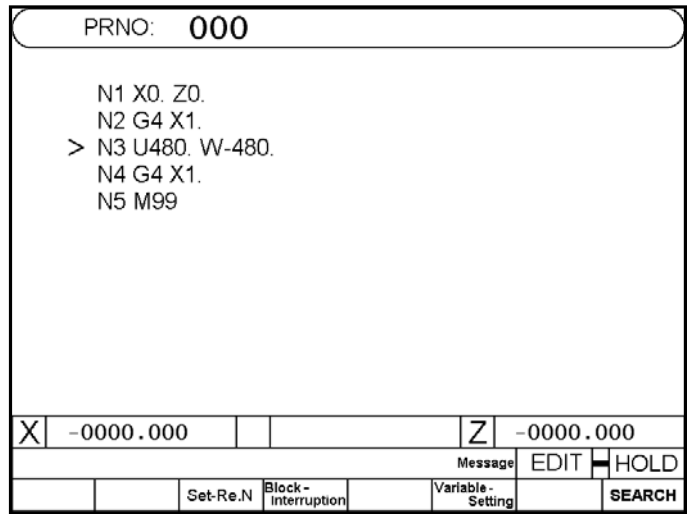

Fig. 2-42

Delete a lo

Ex: Delete the block N31 U20. W-20.

Procedure:

1. Make sure the system is in “EDIT” mode.
2. Use / to move to the cursor to block N31.

Press the key .The screen shows as Fig. 2-43.

Move the cursor to block N4 after the block N31 is deleted.

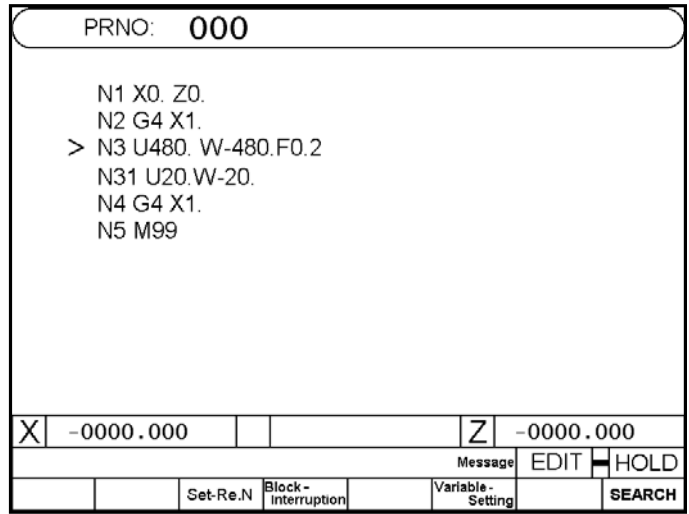

Fig. 2-43

Delete a rora

In the “PRNO” mode, move the cursor to the program to be deleted and press the Delete key. The following message displays:

| | | | | | |
|-----------------------|-----------|----------|------------------------|----------------------|-----------|
| PRNO: 000 | | | | | |
| N1 X0. Z0. | | | | | |
| N2 G4 X1. | | | | | |
| > N3 U480. W-480.F0.2 | | | | | |
| N4 G4 X1. | | | | | |
| N5 M99 | | | | | |
| X | -0000.000 | | | Z | -0000.000 |
| | | | | Message | EDIT |
| | | | | | HOLD |
| | | Set-Re.N | Block- Interruption | Variable- Setting | SEARCH |

Fig. 2-44

At this time, press the Y key to delete the program 002. When you press the N key, no action is performed.

To delete all programs 0~999, follow the procedures below: Procedure:

Switch to the MDI mode and instruct the command 121. All contents in the program are deleted.

Note: After the procedure is complete, all program data in memory is erased. Therefore, never perform this action unless it is absolutely necessary.

2.2.2.2 Enter in Fractions

- (1) The entered command values shall be divided into integral and decimal point numbers, and up to 7 digits shall be entered at most. Because the decimal point cannot be accepted by the command value to be indicated with integral number, there would be no problem for inputting the value for this type of command. As for the decimal point-type command value, the decimal point shall be entered at the appropriate position (the “0” following the decimal point can be omitted); after internal processing by the Controller, its value will be the correct one. Under varied modes, actual command value entered by integral number will also be different. Provided below is about the description of “If to start the decimal point omission” (such parameter is shown in the first page of Parameter screen and it can be accessed by clicking “IO / MCM” for twice.

| Enter | Non-starting Omission | Starting Omission |
|-------|-----------------------|-------------------|
| X2 | X0.002 mm | X2mm |
| Z35 | Z0.035 mm | X35mm |
| U2500 | U2.500 mm | U2500mm |
| W125. | W125.000 mm | W125mm |

- (2) The command value to be entered by integral number:
 G, M, N, S code: Computation parameters.

Question To avoid confusion, except that integral number should be entered for G, M, N and S, other commands will be entered by decimal point method and the “0” following the effective number can be omitted.

2.2.2.3 Edit in Notes

Block Serial Number

- The letter N of the block serial number can be omitted if necessary.
- The number after N is only a symbol. The blocks are sorted in line order rather than the assigned line value.

For instance, if N35 is inserted behind N30, the order is:

Program 1

| | | |
|------------------|-------|--------------|
| N10 G0 X0. Y0. | | First block |
| N20 G4 X1. | | Second block |
| N30 U480. V-480. | | Third block |
| N35 U20. V-20. | | Fourth block |
| N40 G4 X1 | | Fifth block |
| N50 M99 | | Sixth block |

If the block line number N35 is changed to N350 the program executes in the same order.

3. The line number of a block is edited in the form of a "string". That is to say, N10, N010, N0010 represents different blocks and a complete string must be entered to search a block serial number.

❏lo❏ Notes

1. Do not use two G-codes in the same block.
2. Do not repeat any coordinate code of a command, such as X, Y, Z, U, V, I W, J and R, in the same block.
3. If you specify absolute coordinates and incremental coordinates for the same axis in a block, only the incremental coordinates will be executed. Example:
G1 X100. U50.----- Only U50 will be executed.
4. A maximum of 80 characters can be entered in a block, or the Err-08 message displays.

□ □ M Codes

□ □ Co □ □ and Codes

The previous chapters have introduced the format of part programs. This chapter will describe the command codes of the H6D-T series and provide simple examples for each command to explain its applications.

The definition of G-codes in the H6D-T series is similar to other controllers. They are classified into two groups: (Table 3-1)

1. One-shot G-codes

A One-shot G-code (has no * mark in the table) is valid only in the defined program block.

Ex: N10 G0 X30.000 Z40.000
 N20 G4 X2.000 · · · G4 is a one-shot G-code and is valid only in this block.
 N30 G1 X20.000 Z50.000 · · · G04 no longer valid in this block.

2. Modal G-codes

A Modal G-code (has a * mark in the table) is valid until it is replaced by another G-code of the same group.

Wherein G00, G01, G02, G03 Same group.

G40, G41, G42 Same group.

G96, G97 Same group.

G98, G99 Same group.

Ex: N10 G0 X30.000 Z5.000 · · · G0 is defined.
 N20 X50.000 Z10.000 · · · No G-code defined, G0 remains valid.
 N30 G1 X30.000 F0.2 · · · G1 replaces G0 and becomes valid.

The G-codes of H6D-T controller are listed in Table 3-1.

Table 3-1 G-Code Definitions

| G-code | Function |
|--------|--|
| *00 | Positioning (fast feed-rate) |
| ◎*01 # | Linear cutting (cutting feed-rate) |
| ◎*02 | Circular interpolation, CW (cutter at rear) |
| ◎*03 | Circular interpolation, CCW (cutter at rear) |
| 04 | Dwell (Feed-hold) |
| 05 | Parabolic cutting |
| 09 | Exact stop check |
| 15 | Spindle positioning command |
| 16 | Cylindrical plane |
| 17-19 | Plane selection |
| 20 | System measurement in INCH mode |
| 21 | System measurement in METRIC mode |
| 28 | Automatic reference position return |
| 29 | Return from reference position |
| 30 | 2nd reference position return |
| 31 | Skip function |
| ★32 | Thread cutting |
| ★33 | Tapping Cutting Canned Cycle |
| ★34 | Variable lead thread cutting |
| *40 # | Tool radius compensation - cancel |
| *41 | Tool radius compensation - set (left) |
| *42 | Tool radius compensation - set (right) |
| 52 | Local Coordinate System Setting |
| 53 | Basic machine coordinate system |
| 54-59 | Coordinate System Setting |
| * 61 | Exact stop check mode |
| * 62 | Exact stop check mode cancel |
| 70 | Finishing cycle |
| 71 | Longitudinal rough cutting cycle |
| 72 | Face rough cutting cycle |
| 73 | Formed material rough cutting cycle |

| G-code | Function |
|--|--|
| 74 | Face cut-off cycle |
| 75 | Longitudinal cut-off cycle |
| ★76 | Compound thread cutting cycle |
| 80 # | Fixed cycle for drilling cancel |
| * 83 | Deep hole drilling cycle (Z axis) |
| * 84 | Tapping cycle |
| 90 | Longitudinal cutting fixed cycle |
| ★* 92 | Thread cutting fixed cycle |
| * 94 | Face cutting fixed cycle |
| *96 | Constant surface speed control ON |
| *97 # | Constant surface speed control OFF |
| *98 | Feed per minute (mm/min or in/min) |
| *99 # | Feed per revolution (mm/revolution or in/revolution) |
| <p># -- G-codes with "#" are of power-on default setting. * -- G-codes with "*" are modal G-codes. ★-- Function code prefixed with ★ mark needs to be carried out in G99 mode.</p> | |

2 Positioning

Functions and Purposes

This command is accompanied with a coordinate name; it takes the current position as the starting point and the coordinate indicated by the coordinate name as the end point, which are positioned by the linear path.

Format

G00 X(U)____ Z(W)____

X, Z : End point in absolute coordinates.

U, W : End point in incremental coordinates relative to the block starting point.

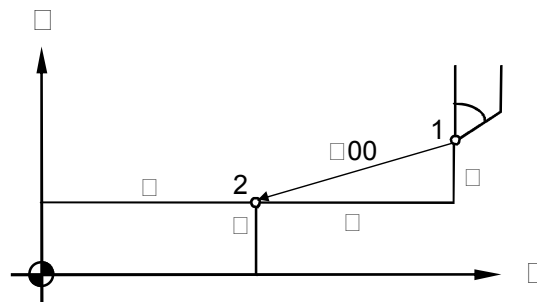

Fig. 3-1 Fast positioning

Details

1. Once this command is given, the G00 mode is kept effective until a G01, G02, G03, or other single-time G command appears. Therefore if a subsequent command is also G00, only the axis address needs to be specified.
2. The speed of positioning is set by a machine parameter.
3. This command is capable of controlling movements in 1-6 axes simultaneously. No position movement will take place if the command gives no axis direction.

Example: Fig 3-2, A point moves to B point rapidly.

G0 X4.00 Z5.60 . . . X and Z-axes are set with absolute commands

G0 U-6.00 W-3.05 . . . X and Z-axes are set with incremental commands

G0 X4.00 W-3.05 . . . X and Z-axes are set with absolute or incremental commands

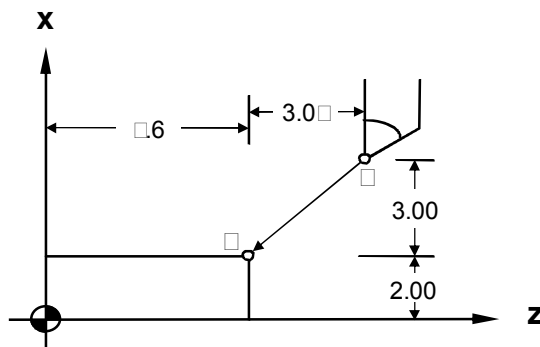

Fig. 3-2 G00 Programming Example

Tool moves to X4.00, Z5.60 rapidly. Since both X and Z axes are repositioning, the tool moves according to the lower feed-rate set in the parameter “Highest Feed-rate”.

Fig. 3-2 assuming that the “Highest Feed-rate” is:

$$X = 5000.00 \text{ mm/min}, Z = 3000.00 \text{ mm/min},$$

Then $F_z = 3000.00$. . . Z-axis feed-rate

$$F_x = 3000.00 * (3.00/3.05)$$

$$= 2950.82 \text{ (less than } 5000.0, \text{ X-axis set value)} \text{ . . . X-axis feed-rate}$$

The feed rate of both axes is within the MCM parameter settings. Therefore, the tool will feed at the calculated rate on both axes.

When only a single axis (X or Z) executes fast positioning, it moves at the respective speed set in the “Highest Feed-rate” parameter.

Linear Cutting

Functions and Purposes

This command, together with the coordinates and a feed speed command, makes the tool to move from the current position to the end point specified by the coordinates in a linear movement at the speed specified by address F.

For:

G01 X(U)____ Z(W)____ F____

X, Z : End point in absolute coordinates

U, W : End point in incremental coordinates relative to the start point of the program block.

F : Cutting feed-rate (F-code can be used in combination with any G-code)

The F-code can be used in the G00 block without affecting the fast positioning movement.

Details

1. G01 (or G1) is used for linear cutting work. It can control the X, Z-axes simultaneously. The cutting speed is determined by the F-code. The smallest setting value of the F-code is 0.02 mm/min or 0.2 in/min.
2. Once this command is given, the G01 mode is kept effective until a G01, G02, G03, or other single-block G command appears. Therefore if a subsequent command is also G01 and the feed speed is not changed, only the coordinate value needs to be specified.
3. The starting point is the coordinate of the tool when the command is given. The feed-rate defined after an F-code (Modal code) remains valid until it is replaced by a new feed-rate.

The formula to calculate X, Z cutting feed-rate:

(U and W are actual incremental values.)

$$\text{X feed-rate, } F_X = \frac{U}{\sqrt{U^2 + W^2}} \times F \quad (1)$$

$$\text{Z feed-rate, } F_Z = \frac{W}{\sqrt{U^2 + W^2}} \times F \quad (2)$$

Example: Start point is X=2.0 (diameter), Z=4.60.

G01 X4.00 Z2.01 F0.300 · · · Absolute command

G01 U2.00 W-2.59 F0.300 · · · Incremental command

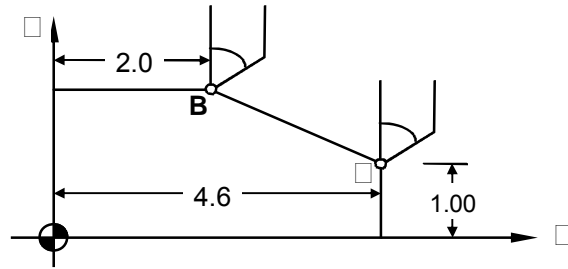

Fig. 3-3 G01 Programming Example

2 Circular Interpolation

Functions and Purposes

This command makes the tool move along an arc.

Format:

```
G02 X(U)___ Z(W)___ I___ K___ F___
```

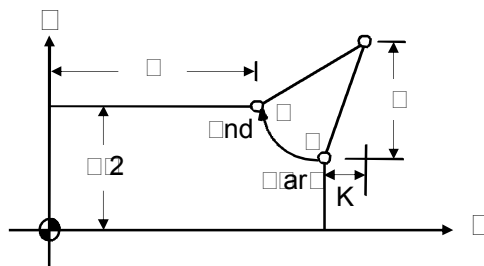

Fig 3-4 G02 Arc cutting

```
G03 X(U)___ Z(W)___ I___ K___ F___
```

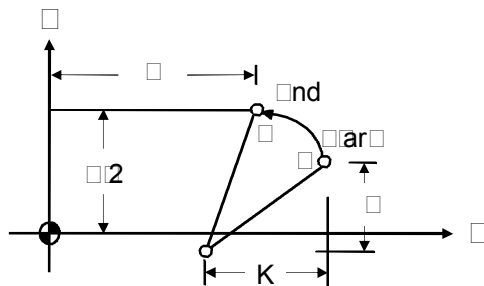

Fig 3-5 G03 Arc Cutting

G02 X(U)____ Z(W)____ R____ F____

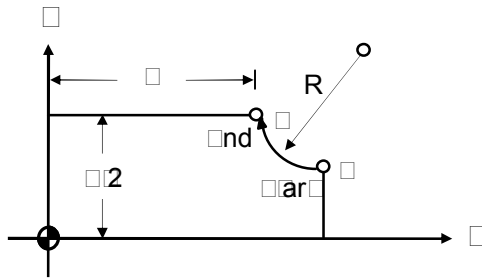

Fig. 3-6 Defined by Radius “R”

Details:

1. The arc-cutting program contains four command groups, as showed in the list below. The combination of these commands determine the arc path of the tool in a single block.

Table 3-2

| | | Command | Description |
|---|---|---|--|
| 1 | Arc feed direction | G02 G03 | Clockwise Counter clockwise |
| 2 | End point | Absolute command X, Z Incremental command U, W | End point in absolute coordinates Increment from arc start point to end point |
| 3 | Difference from arc start point to center Arc radius | I, K R | I=X-axis, K=Z-axis Radius range -9999.~9999.mm |
| 4 | Arc feed-rate | F | Minimum setting 0.01 mm/rot. |

2. The end point can be defined either by absolute or incremental coordinates. The size of the arc can be defined either by the coordinate difference or radius. The arc cutting direction (CW or CCW) is relative to the center of the arc. Note that the CW or CCW direction is determined when the tool is at the top (rear) holder. The direction is reversed when the tool is at the bottom (front) holder.

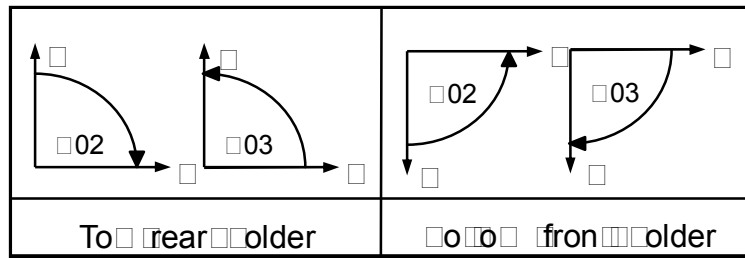

Fig. 3-7 G02, G03 Direction

Arc cutting command:

Table 3-3

| | Top (rear) holder | Bottom (front) holder |
|-----|-------------------|-----------------------|
| G02 | Clockwise | Counter clockwise |
| G03 | Counter clockwise | Clockwise |

3. An arc comprises three elements, a start point, and end point and a center (See Fig. 3-8).
 - a. The start point (S) is the tool coordinates when the G02 and G03 execute.
 - b. The end point (E) is the coordinates of X (U) and Z (W) in the program format.
 - c. The center (C) is defined by I and K values. They are the coordinate difference between the arc start point and center. This value can be either positive or negative. Definition of the I and k values are same as the increments (U, W). The arc feed-rate is defined by F-value.

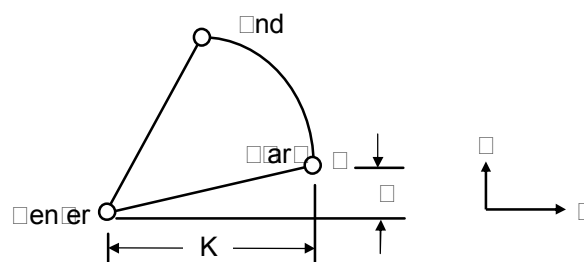

Fig. 3-8 Arc cutting

- d. The arc center can be defined by the radius instead of I and K. But if the arc angle is between -1° and 1° or 179° and 181° , only I and K can be used for setting.

□□a□ple□

1. The following four commands are different in settings but execute the same arc cutting work.
 - a. G02 X5.000 Z3.000 I2.500 F0.3
 - b. G02 U2.000 W-2.000 I2.500 F0.3
 - c. G02 X5.000 Z3.000 R2.500 F0.3
 - d. G02 U2.000 W-2.000 R2.500 F0.3

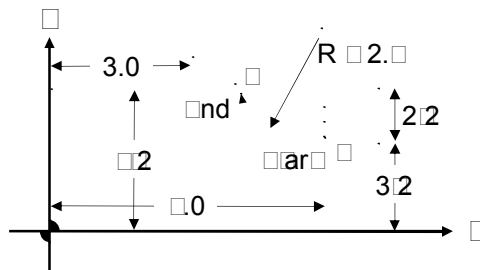

Fig. 3-9 G02 Programming Example

2. There are two different arc types available for arc cutting (Fig. 3-10):
 - a. Use "+R" if arc angle $< 180^\circ$.
 - b. Use "-R" if arc angle $> 180^\circ$.

R is within the range from -4000.mm to +4000.mm.

□□ In Fig. 3-10, an arc is cut with an angle $< 180^\circ$ (+R):

```
G02 Z60.000 X20.000 R50.000 F0.300
```

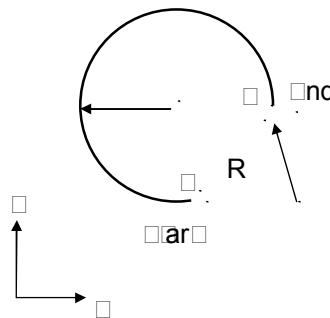

Fig. 3-10 Arc cutting

Please note the following when executing an arc cutting:

1. The F-value of the cutting speed is given in a G02/G03 command, indicating the speed along the tangent to the arc; this tangent speed is limited by the arc radius and the given speed limit.
2. When the calculated tangential cutting speed of the arc is greater than the F value of the program, the F-value is used as the tangential cutting speed. Otherwise, the calculated value prevails.
3. The maximum tangential cutting speed is estimated with the following formula:

$$F_c = 0.5 \times \sqrt{R \times 1000} \text{ mm/min}$$

Where R= Arc radius in mm.

□□□ **Dwell** □□□□

Functions and Purposes

This function's purpose is to temporarily hold the machine movement via the program command, realizing a waiting status, therefore delaying the start of the subsequent block.

Format:

G04 X(P)_____

- X: Dwell Time. Unit: second. (The X here stands for time instead of position, is dependent on the setting of “decimal enable” parameter. Ex.: G04 X2, when “decimal enable” is disabled, the dwell time is 2s; if “decimal enable” is enabled, the dwell time is 0.002s – i.e. 2ms.)
- P: Dwell Time. Unit: millisecond. (Not dependent on the setting of “decimal enable” parameter.)

Details

To meet machining requirements, the axial movement may need to be held during the execution of a program block, which completes before the command for the next block is executed. This command can be used for this purpose. The G04 function is used for this purpose.

The minimum dwell time is 0.001 sec, the maximum is 8000.0 seconds.

Ex: N1 G1 X10.000 Z10.000 F0.1
 N2 G4 X2.000 hold for 2 seconds
 N3 G00 X0.000 Z0.000

6 Parabolic Motion

Function and purpose :

The function will make the tool along a parabolic mobile.

For

G05 X(U)___ Z(W)___ P___ I___ K___ J___ F___

X,Z : The parabola the end of the absolute coordinates value.

U,W : The parabola the end of the incremental value relative to the starting point of the single block.

Note : When parabolic End X coordinate and the parabola starting point X coordinate equal, display will showing “ERROR 05 .X”.

When parabolic End Z coordinate and the parabola starting point Z coordinate equal, display will showing “ERROR 05 .Z”.

P : Parabolic program $X^2=4PZ$ P value, Range (1~9999999) , Unit : 0.001mm, Degree of opening of said parabolic shape. (When $P \leq 0$, system will showing “ERROR 05.P” to the display)

I : The parabola X-axis interpolation step value, Range(0.001~9999.999) , Step away from the smaller, the precision will more higher. (When the X-axis step distance value $I \leq 0$, system will showing “ERROR 05 .I” to the display)

K : K=0 Counterclockwise parabolic parabola trajectory from the beginning to the end.

K=1 Parabolic trajectory from the beginning to the end clockwise parabolic.

The system default counterclockwise parabolic when K not fill.

J : J=0 The parabola command in convenient processing can do tool compensation, but the surface finish is not high.

J=1 The parabola command in at the point of interruption, can not do the tool compensation but high surface finish.

The system default J=0 when J not fill.

F : Speed feed-rate (Can be used in conjunction with any G-code).

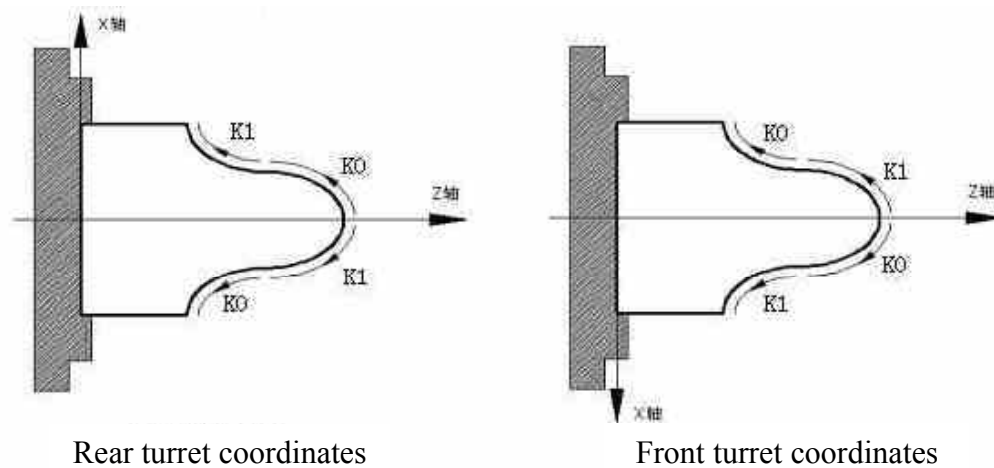

Fig 3-11 K explanation

Example :

When Parabolic command P=5mm, Its symmetry axis parallel to the Z-axis machining dimensions of the parts shown in the Figure, the finishing program may be prepared as follows :

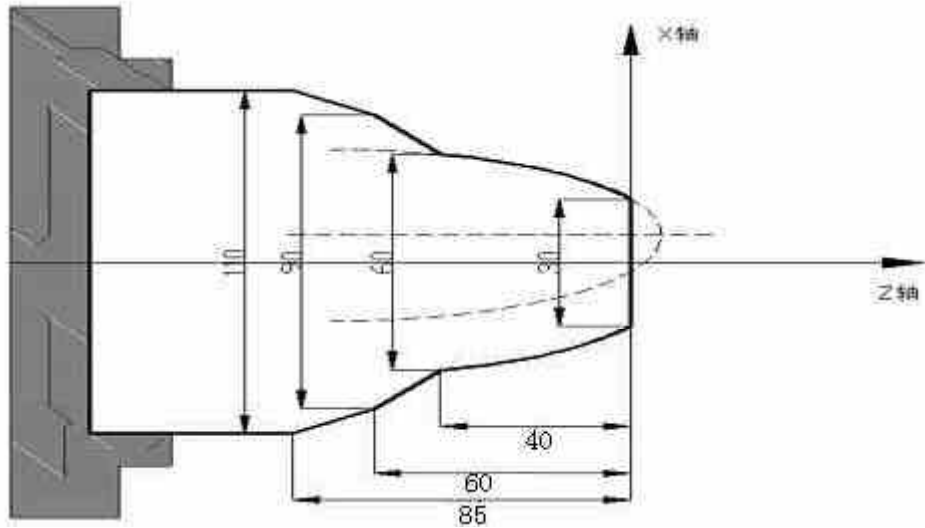

Fig 3-12

```

M03 S800
G00 X10. Z10.
G00 X0.
G01 Z0. F120
M08
X30.
G05 X60. Z-40. P5000 K0 I1.
G01 X90. Z-60.
X110. Z-85.
X120.
M09
G00 Z10.
M30
    
```

Functions and Purposes

This command provides the option of precision positioning for certain blocks (MCM#114 = 256, Turning Corner Round Angle Connection), if so required, when M300 (round-angle connection between blocks) is enabled.

Format

- G09 Exact stop check (effective between 2 blocks posterior to a G09 command)
 G61 Exact stop check mode (modal command, to be disabled by a G62 command when enabled).
 G62 Exact stop check mode cancel (modal command, to disable an enabled G61)

Example (MCM#114 = 256, Turning Corner Round Angle Connection)

```

M03 S1000
G01 X20. F1000
U10.
N10 U50.
      G09 ----- N20 and N21 Precision Positioning between blocks, on
                    completion of N20 block, X-axis speed decelerates to 0.
N20 U50.
N21 U50.
      G61 ----- Precision Positioning between blocks enable (N30---N50)
N30 U50.
N40 U50.
N50 U50.
      G62 ----- Precision Positioning between blocks disable
... ..
... ..
... ..
G00 X0.
M30
  
```

G15 Spindle Positioning Command

Functions and Purposes

This command sets the Spindle to a Position.

Format

G15 R _____ P _____

Parameters:

R: Stands for the Target Angle of Spindle Positioning

P: Stands for rpm of Spindle Positioning

Details

R Parameter Format: With decimal point or omit decimal point and add 2 zeros at the end.

Example

EX.: For spindle to be positioned at the angle of 175 degrees, any of the following commands may be given:

Method 1: G15 R175.00

Method 2: G15 R175.

Method 3: G15 R17500

G16 Cylindrical Plane

Functions and Purposes

Using the angular movement of an angle command, convert it internally into a linear distance of the axis on the outer surface, for performing a linear interpolation or arc interpolation with another axis. After the interpolation, this distance is again converted into the movement of the rotating axis.

ro ra For at

1. Directly specify a cylinder interpolation axis and cylinder radius.
 - G16 Yxxxx.xxx: Set Y-axis as the cylinder interpolation axis, xxxx.xxx as value of cylinder radius.
 - G16 Axxxx.xxx: Set A-axis as the cylinder interpolation axis, xxxx.xxx as value of cylinder radius.
 - G16 Bxxxx.xxx: Set B-axis as the cylinder interpolation axis, xxxx.xxx as value of cylinder radius.
 - G16 Cxxxx.xxx: Set C-axis as the cylinder interpolation axis, xxxx.xxx as value of cylinder radius.

2. Only set the value of cylinder radius; the cylinder interpolation axis to be determined by the currently used spindle. (I.e., the axial direction for switching from the spindle mode to the servo axis mode.)
 - G16 Hxxxx.xxx : Set xxxx.xxx as the value of cylinder radius.

When set with this method, the cylinder interpolation axis to be determined by the currently using spindle, and the current spindle must be converted into servo axis for performing cylinder interpolation.

Ex: First Spindle (C-axis) to be switched over to servo spindle mode for performing cylinder interpolation.

```

.....
N01 M50          ... First spindle switched into servo mode
N10 G01 C0.     ... Positioning
N20 G18 Z0 C0   ... Select Z-C plane
N30 G16 H20.    ... Cylinder interpolation enable, C-axis is
                  cylinder interpolation axis; cylinder radius
                  20mm.
N40 G42 Z10.F1.0 ... Interpolate Tool Tip Radius Offset
N50 G01 Z10.C30. ... Linear Interpolation
N60 G03 Z40.C60.R30. ... Arc Interpolation
N70 G01 Z60.C90. ... Linear Interpolation
N80 G40 Z90.    ... Tool Tip Radius Offset disable

```

Example

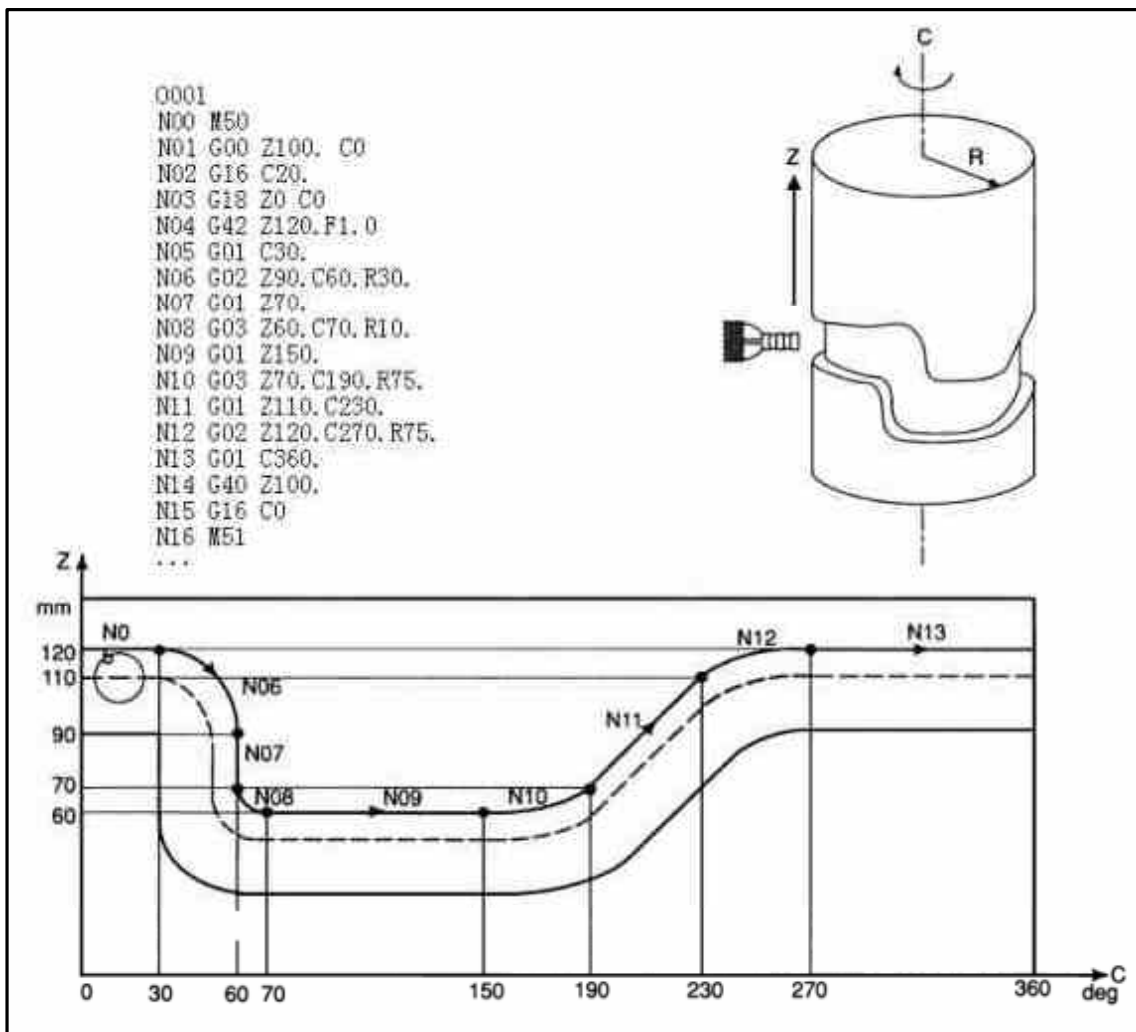

Fig. 3-13 Cylinder Interpolation

1.1 Plane Setup 1-1

Functions and Purposes

This command is for selecting a control plan or the plane where an arc is located.

Format

- If no axis direction is specified after a G17, G18, or G19 command, the arc plane is the default plane as shown below:

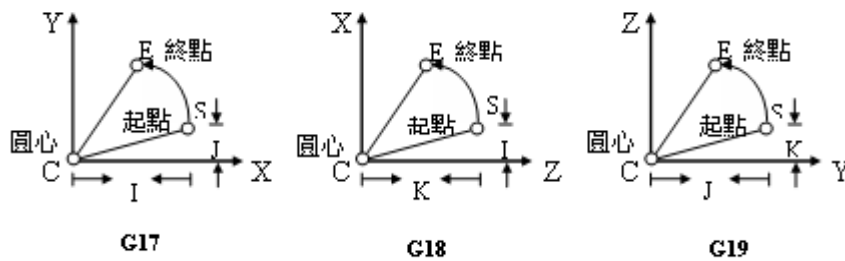

Fig. 3-14 Arc Plane

Table 3-4

| Command | Horizontal Axis | Vertical Axis |
|--------------------------|-----------------|---------------|
| G17 (IJ Plane selection) | X | Y |
| G18 (KI Plane selection) | Z | X |
| G19 (JK Plane selection) | Y | Z |

2. G17, G18, G19 command may alter any of the horizontal axes or vertical axes.

□1□ (I-J Plane Selection)

Table 3-5

| Command | Horizontal Axis | Vertical Axis |
|--------------------|-----------------|---------------|
| G17 X0 Z0 | X | Z |
| G17 X0 A0 | X | A |
| G17 X0 B0 | X | B |
| G17 X0 C0 | X | C |
| G17 Z0 Y0 | Z | Y |
| G17 A0 Y0 | A | Y |
| G17 B0 Y0 | B | Y |
| G17 C0 Y0 | C | Y |
| G17 X0 Y0 (or G17) | X | Y |

□1□ (K-I Plane Selection)

Table 3-6

| Command | Horizontal Axis | Vertical Axis |
|--------------------|-----------------|---------------|
| G18 Z0 Y0 | Z | Y |
| G18 Z0 A0 | Z | A |
| G18 Z0 B0 | Z | B |
| G18 Z0 C0 | Z | C |
| G18 Y0 X0 | Y | X |
| G18 A0 X0 | A | X |
| G18 B0 X0 | B | X |
| G18 C0 X0 | C | X |
| G18 Z0 X0 (or G18) | Z | X |

□1□ (J-K Plane Selection)

Table 3-7

| Command | Horizontal Axis | Vertical Axis |
|--------------------|-----------------|---------------|
| G19 Y0 X0 | Y | X |
| G19 Y0 A0 | Y | A |
| G19 Y0 B0 | Y | B |
| G19 Y0 C0 | Y | C |
| G19 X0 Z0 | X | Z |
| G19 A0 Z0 | A | Z |
| G19 B0 Z0 | B | Z |
| G19 C0 Z0 | C | Z |
| G19 Y0 Z0 (or G19) | Y | Z |

Note□

1. In a plane layout command, there is no fixed sequence for the horizontal and vertical axes. EX.: G17 X0 Z0 = G17 Z0 X0 ◦
2. In G17, always use the IJ value to indicate the radial increment from the start point of an arc.

In G18, always use the KI value to indicate the radial increment from the start point of an arc.

In G19, always use the JK value to indicate the radial increment from the start point of an arc.

EX.:

G17 X0 Z0 (Select X/Z plane)

G02 X10. Z10. J10. (J stands for the radial increment of the arc from the starting point of the vertical axis (Z-axis) (to the center of the arc).

G28 Auto Reference Position Return

Functions and Purposes

Via a G28 command, the specified axis is returned to the first reference point at the high feed-speed of the respective axis.

Format:

G28
 or G28 X(U)_____ Z(W)_____
 or G28 X(U)_____
 or G28 Z(W)_____

Example

Note that prior to executing the G28 command, the tool compensation command must be canceled.

Ex:

| | | |
|------------|-------|---|
| G00 X1. Z1 | · · · | (From start-point to the intermediate point) |
| T100 | · · · | Tool compensation is canceled (<u>it cannot co-exist with G28 in the same block</u>). |
| G28 | · · · | Tool returns to the 1st reference point on the X / Z-axis. |

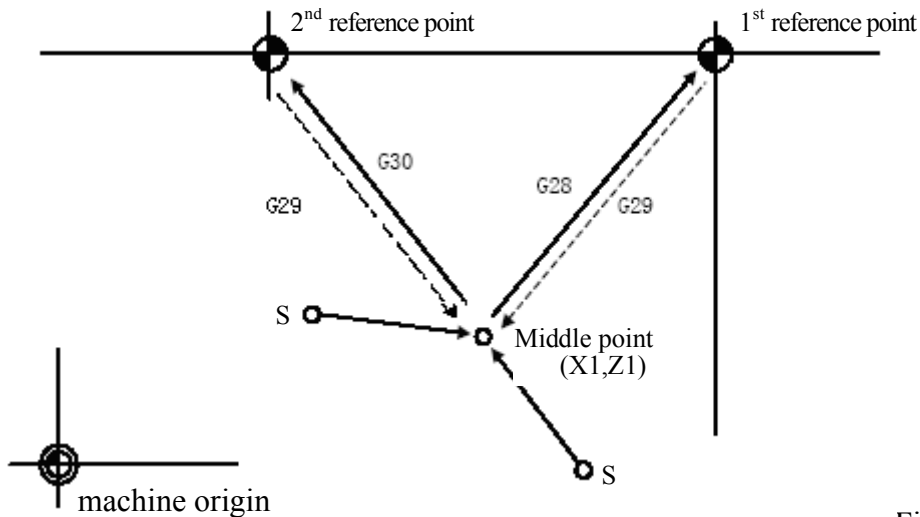

Fig. 3-15

Details

1. The first reference point coordinates are set based on the X, Z, and settings in MCM parameter G28.
2. The X, Z values in this format are not used. They only indicate which axis is to return to the reference point. Therefore, regardless of whether G28 is an independent block or contains X, Z commands simultaneously, the tools return to the reference point based on the X, Z settings of the MCM parameter.
3. Prior to executing G28, tool offset must be disabled.

G28 Return From Reference Position

Functions and Purposes

After returning to the reference point by executing G28, use this (G29) command to return to the previous target point prior to G28.

Format

- G28
- or G28 X(U)_____ Z(W)_____
- or G28 X(U)_____
- or G28 Z(W)_____

Example

EX: N1 G00 X1. Z1. . . . (From start-point to intermediate point)
 N2 T00 . . . Offset disabled (shall not situate at the same block with G28)
 N3 G28 . . . X-Axis/Z-Axis returns to first reference point
 N4 G29 . . . Program returns from first reference point to (X1, Z1).
 (See Fig. 3-15)

As the example above, the N3 block may have the following combinations:

N4 G29 X _____ Z _____ . . . Return to (X1, Z1.)
 N4 G29 X _____ . . . Tool returns to X1.
 N4 G29 Z _____ . . . Tool returns to Z1.

Details

1. The X/Z Value in the program format is insignificant; however, a value must be given for entering into the program, it merely tells the machine to which axis the reference point is to be returned.
2. After executing G28, use G29 command to return the tool to its previous position before G28 is executed.
3. The G29 command cannot be used alone. A G28 or G30 must be given prior to G29.

2nd Reference Position Return

Functions and Purposes

Via G30 command, the specified axis is returned to the second reference point at high feed-speed of the respective axis.

Format:

G30
 or G30 X(U)_____ Z(W)_____
 or G30 X(U)_____
 or G30 Z(W)_____

Execution of this command is the same as G28, but the reference point is set in MCM parameter G30. (See Fig 3-15)

□1 □ Thread Cuttin □□ □2

Fun□tions and □urposes□

G32 command performs spindle rotation by synchronized control of tool-feed; therefore it is capable of processing linear thread cutting, inclined thread cutting and continuous thread cutting.

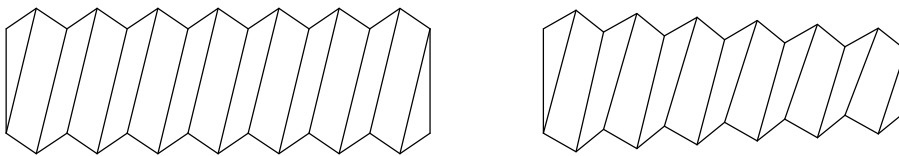

Fig. 3-16 G32 Thread cutting

For□at□

G32 X(U) _____ Z(W) _____ F _____ Q _____ E _____

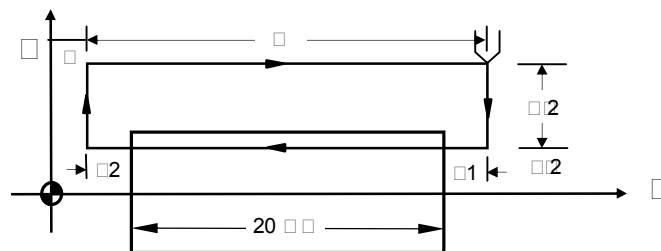

Fig. 3-17 Thread Cutting

(The U/2 Setting Should Not be Less Than Retraction Amount)

- X, Z : End point of thread cutting in absolute coordinates
- U, W : End point of thread cutting in incremental coordinates relative to the start point.
- F : Thread pitch

- Q : Start-angle of thread cutting; default value: Q=0 (range of angle is 0-359 without a decimal point)
- E : Number of threads per inch; range: 1.0-100.0. This setting shall not appear when an F setting is given.

Details □

- Both fine cut and rough cut of the thread cutting proceed along the same path. The cutting action on the Z-axis does not start until the Grid signal is received from the spindle. All repeated cutting actions start at the same point.
- Due to delay of the server system, imperfections could result at both ends of the thread (S1 and S2). To avoid this problem, the thread length specified in the program should be slightly longer than the actual length of the processed thread. S1 and S2 are leads. The length of S1 and S2 is estimated using the formula below.

$$S1 = (S * F/1800) * (-1 - \ln A)$$

$$S2 = (S * F/1800)$$

S1, S2 : Imperfect thread length, mm

S : Spindle speed, rpm

F : Thread pitch, mm

A : Acceptable thread error

Relationship between A and (-1 - Ln A):

Table 3-8

| A | -1 - Ln A |
|-------|-----------|
| 0.005 | 4.298 |
| 0.010 | 3.605 |
| 0.015 | 3.200 |
| 0.020 | 2.912 |
| 0.025 | 2.689 |

□□a□ple :

Ex 1: Non-tapered thread cutting

Specifications: Thread pitch $F = 2 \text{ mm}$,
 cutting lead starts $S1 = 3 \text{ mm}$,
 cutting lead ends $S2 = 3 \text{ mm}$,
 Thread depth $= 1.4 \text{ mm (in diameter) by 2 cuts}$

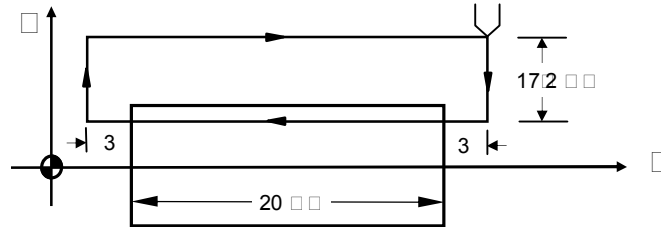

Fig. 3-18 Non-tapered Thread Cutting

```

N10 G0 X30.0 Z50.0
N20 M03 S2000
N30 G0 U-17.000 (first cut = 1.0/2mm)
N40 G32 W-26.000 F2.00
N50 G0 U17.000
N60 W26.000
N70 G0 U-17.400 (second cut = 0.4/2mm)
N80 G32 W-26.000 F2.00
N90 G0 U17.400
N100 W26.000
N110 M05
N120 M02
    
```

Ex 2 : Tapered thread cutting

```
G32 X(U) _____ Z(W) _____ F _____ R _____ Q _____ E _____
```

- X, Z : End point of thread cutting in absolute coordinates.
- U, W : End point of thread cutting in incremental coordinates relative to the start point.
- F : Thread pitch.
- R : Half of the difference (diameter) between the greater and smaller ends of the tapered thread.
- Q : Start-angle of thread cutting; default value: $Q=0$ (range of angle is

0-359 without a decimal point)

E : Number of threads per inch; range: 1.0-100.0. This setting shall not appear when an F setting is given.

Specifications:

Thread pitch F=2 mm
 Cutting lead starts S1 = 2 mm,
 Cutting lead ends S2 = 2 mm,
 Thread depth = 1.4 mm (diameter) formed by two cutting
 actions.

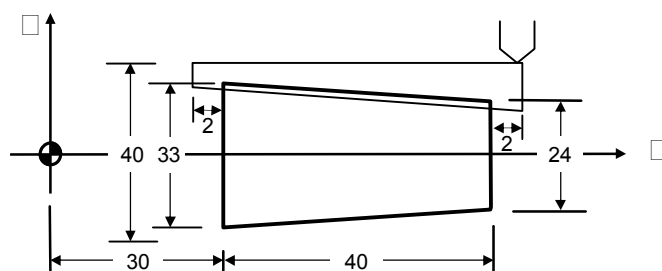

Fig 3-19 Tapered Thread Cutting

Note □ Tapered thread

- For the angle between taper plane and Z-axis less than 45° , pitch shall be set along the Z-axis.
- For the angle between taper plane and Z-axis more than 45° , pitch shall be set along the X-axis.
- For the angle between taper plane and Z-axis equal to 45° , pitch can be set along either the X-axis or Z-axis.

N10 G0 X60.0 Z100.0

N20 M03 S2000

N30 G0 X23.0 Z72.0 (First cut = 1.0/2mm)

N40 G32 X32.000 Z28.000 F2.00 R-4.5

N50 G0 X40.000

N60 Z72.000

N70 G0 X22.6 (Second cut = 0.4/2mm)

N80 G32 X31.6 Z28.0 F2.00 R-4.5

N90 G0 X40.000

N100 Z72.000

N110 M05

N120 M02

Ex 3 : Multi-stage continuous thread cutting

```
G00 Z0.
M03 S3000      ; Quick positioning to start point
G32 Z50.F1.    ; Thread of first stage
G32 Z100.F2.   ; Thread of second stage
G32 Z150.F3.   ; Thread of third stage
M05
M30
```

If set as above, the thread cutting process will have no stop in the Z-axis during thread cutting, therefore the cut threads are **smooth and continuous**.

11 Tapping Canned Cycle

Purpose and Function

Rigid thread cutting

Code and Format

```
G33 Z(W)_____ F _____
G33 X(U)_____ F _____
```

Z(W) X(U) : End-point coordinate or length of thread cutting
 F : Pitch

Details Execution process of Z/X-axis thread cutting

1. Z/X Axis feed of thread cutting
2. Switch off spindle
3. Wait until the spindle fully stops
4. Reverse the spindle (in the opposite direction of the original rotation)
5. Z/X-axis tool retracts

6. Spindle stops

G33 **Parallel One-end thread with 1mm pitch (e.g., in Z-axis):**

```
N10 M3 S800
N20 G33 Z100. F1.0
N30...
```

Note 1: Ensure the spindle rotation is in the threading direction before starting thread cutting. Spindle will stop rotation when the thread cutting is completed. For the subsequent process, start the spindle as required.

Note 2: Since this command is a rigid thread cutting, when a spindle stop command is enabled, the spindle decelerates for a certain period of time before reaching the full stop, and Z-axis will still move along with spindle rotation before spindle fully stops. Therefore for the actual process, the end of thread cutting will be a little bit deeper than the actual requirement.

Note 3: Other precautions are the same as that of G32 Thread Cutting.

G34 Variable Lead Thread Cutting

Functions and Purposes

Applicable for processing variable lead threads

Code and Format

G34: X(U)___ Z(W)___ F___ K±___ Q___ E___

- 1) Parallel thread: G34 Z(W)___ F___ Q___ K___;
- 2) Tapered thread: G34 X(U)___ Z(W)___ F___ Q___ K___;

X、Z : End point of thread cutting in absolute coordinates

U、W : End point of thread cutting in incremental coordinates relative to the start point

F : Thread Pitch

K : Start-angle of thread cutting; default value: Q=0 (range of angle is

0-359 without a decimal point)

E : Number of threads per inch; range: 1.0-100.0. This setting shall not appear when an F setting is given.

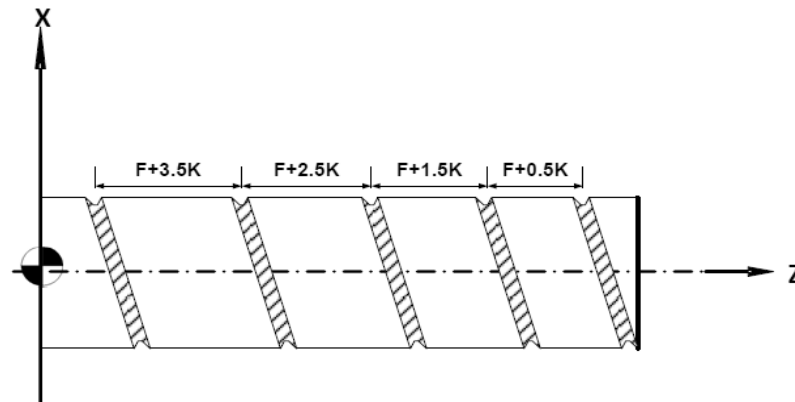

Fig.3-20

Details □

1. For single stage thread cutting, fine cutting and rough cutting are along the same path, therefore when starting the thread cutting, it waits for a GRID signal to be detected from the spindle position before starting Z-axis for cutting action (L parameter left blank or set as 0). Each repeated cutting starts from this fixed point.
2. For multi-stage thread cutting, based on technical requirements, in general the subsequent stages starting from the second stage do not need to detect the GRID signal mainly for connecting smoothly with the previous stage. (See Fig.3-20)
3. In general incomplete end threads (S1 and S2) occur due to time lag in the servo system, therefore the specified thread length shall be slightly longer than the processed thread length. S1 and S2 are called thread leads. A simple way to calculate the length of incomplete threads S1 and S2 is shown as follows:

$$S1 = (S * F/1800) * (-1 - \ln A)$$

$$S2 = (S * F/1800)$$

S1,S2: Length of incomplete threads, mm

S : Spindle rotation, rpm

F : Pitch, mm

A : Thread tolerance

Relation ship between A and (-1 - Ln A) is as follows:

Table 3-9

| A | -1 - Ln A |
|-------|-----------|
| 0.005 | 4.298 |
| 0.010 | 3.605 |
| 0.015 | 3.200 |
| 0.020 | 2.912 |
| 0.025 | 2.689 |

□□a□ple □ro□ra□ 1: (parallel thread cutting with equal pitch)

Cutting specification: Pitch $F = 2 \text{ mm}$,
 Lead for start-of-cutting $S1 = 3 \text{ mm}$,
 Lead for end-of-cutting $S2 = 3 \text{ mm}$,
 Cutting depth $= 1.4 \text{ mm (diameter)}$, in 2 cutting sessions

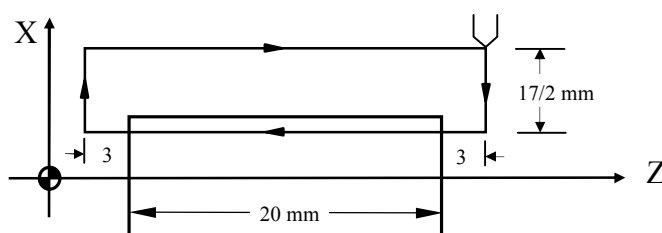

Fig.3-21 Parallel thread cutting with equal pitch

```

N10 G0 X30.0 Z50.0
N20 M03 S2000
N30 G0 U-17.000 (first cutting 1.0/2mm)
N40 G34 W-26.000 F2.00 K0.5
N50 G0 U17.000
N60 W26.000
N70 G0 U-17.400 (second cutting 0.4/2mm)
N80 G34 W-26.000 F2.00 K0.5
N90 G0 U17.400
N100 W26.000
N110 M05
N120 M02

```

Example 2: (Tapered thread cutting)

Cutting specifications: Pitch $F = 2 \text{ mm}$,
 Lead for start-of-cutting $S1 = 2 \text{ mm}$,
 Lead for end-of-cutting $S2 = 2 \text{ mm}$,
 Cutting depth $= 1.4 \text{ mm (diameter)}$, in 2 cutting sessions

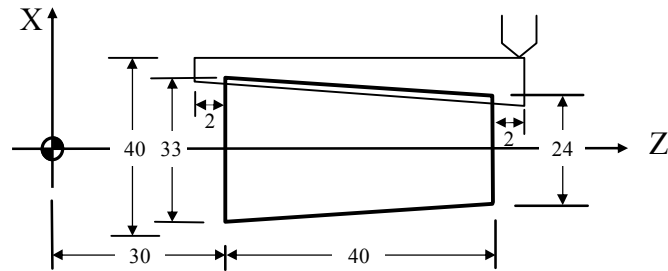

Fig.3-22 Tapered thread cutting

Tapered threads, for angle between taper plane and Z-axis less than 45° , pitch shall be set along Z-axis, for angle between taper plane and Z-axis more than 45° , pitch shall be set along X-axis.

```

N10 G0 X60.0 Z100.0
N20 M03 S2000
N30 G0 X23.000 Z72.000 (First cutting 1.0/2mm)
N40 G34 X32.000 Z28.000 F2.00 K0.5
N50 G0 X40.000
N60 Z72.000
N70 G0 X22.600 (Second cutting 0.4/2mm)
N80 G34 X31.600 Z28.000 F2.00 K0.5
N90 G0 X40.000
N100 Z72.000
N110 M05
N120 M02
    
```

Multi-stage thread cutting with variable-pitches

As shown in Fig.3-21, the first 2 stages are variable-pitch threads with $F=1.0\text{mm}$,

$K=0.5\text{mm}$; the transition from first stage to second stage is a smooth connection; threads of the third stage have an equal pitch $F=3.0\text{mm}$, the transition from second stage to third stage is a smooth connection.

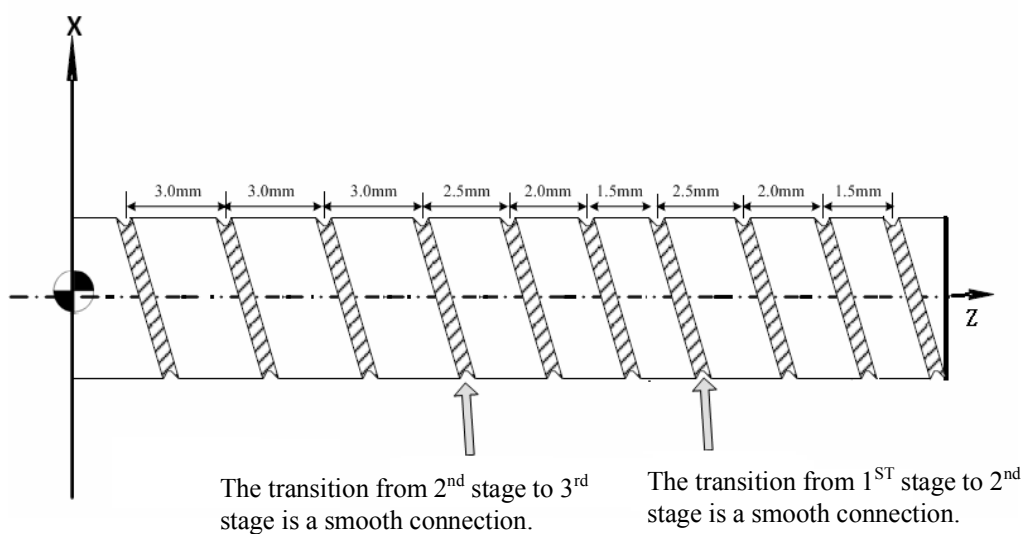

Fig.3-23 Multi-stage thread cutting with variable pitches

Example

T03

M03 S1000

M08

G00 X0.0 Z0.0

; Quick positioning to start point

G34 Z-30.0 F1.0 K0.5

; Thread of first stage with variable pitch

G34 Z-50.0 F1.0 K0.5

; Thread of second stage with variable pitch

G32 Z-60.0 F2.0

; Thread of third stage with equal pitch

M09

M05

M30

If set as above, the thread cutting process will have no stop in Z-axis during thread cutting, therefore the cut threads are **smooth and continuous**.

3.1 Canned Cycle Functions For application of programs in

The canned cycle function is a special G-code of command groups. It comprises canned cycle cutting actions commonly used in machining processes. The command groups of H6D-T Series are classified into single canned cycle and compound canned cycle command groups. Both are handy and effective in programming and applications.

3.1.1 Linear Cutting Canned Cycle 2

Functions and Purposes

This command group executes repeated cutting with a block. It should end with G01 after use; otherwise, the cutting cycle will repeat.

1. Longitudinal Cutting Feed Cycle

Format

G90 X(U)___ Z(W)___ F___

- X, Z : End point C in absolute coordinates (Fig. 3-22)
- U, W : End point C in incremental coordinates relative to the start point A
- F : B~C~D feed-rate

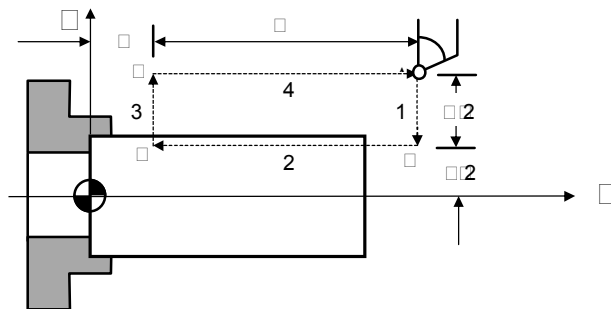

Fig. 3-24 G90 Linear Cutting Path

Details

In Fig. 3-22, the cutting paths 1 and 4 are fast positioned by G00. The cutting along the paths 2 and 3 is executed at the feed-rate F. Whenever the start button (CYCST) is pressed in a block, the tool moves along the paths 1~2~3~4 to execute a cutting cycle.

2 Outer Inner Diameter Tapered Lateral Canned Cycle
Format

G90 X(U)___ Z(W)___ R___ F___

R : The difference between point B and C in radius.

X, Z, U, W and F are identical to those in lateral linear canned cycle.

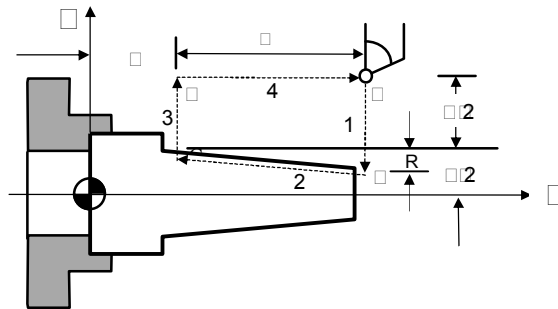

Fig. 3-25 G90 Tapered Cutting Path

Details

When using incremental coordinates, the signs (+/-) of U and W are determined by the tool's direction of movement. If the direction is positive, the increment of U and W is (+), and vice versa. R value is as Fig. 3-26.

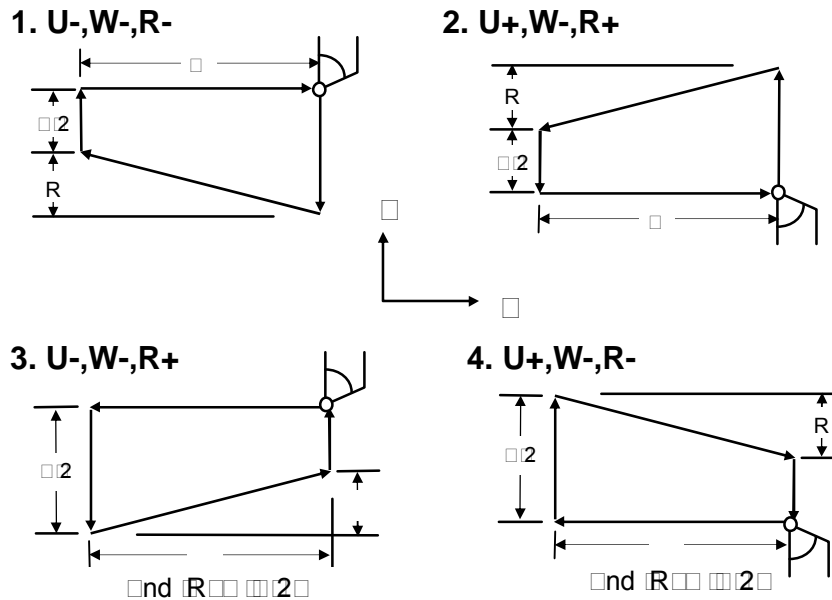

Fig. 3-26 G90 Cutting Path and Direction

Thread Cutting Fixed Cycle

The advantage of the G92 block is that it functions as four G32 blocks.

Format

G92 X(U) ___ Z(W) ___ I ___ K ___ L ___ Q ___ F ___ E ___

- X, Z : End point C in absolute coordinates
- U, W : End point C in incremental coordinates
- F : Thread pitch (metric)
- E : Number of threads per inch range from 1.0-100.0. This setting shall not appear when an F setting is given.
- I : The axial travel length on X-axis for ending of the thread cutting. If K ≠ 0, "I" will be omitted and regarded as 2*K (i.e. ending of the thread

cutting at 45°).

- K : The axial distance on Z-axis from the start point to the end point for the end of thread cutting.
- L : Multiple-thread setting. Range:1~9. For G92 only.
"L" is a modular value and valid all the time once it is set. If L and "Q" are set at the same time, the L-value will be regarded as invalid.
- Q : Offset setting of the thread initial angle. Range: 0~359. For G92 only.

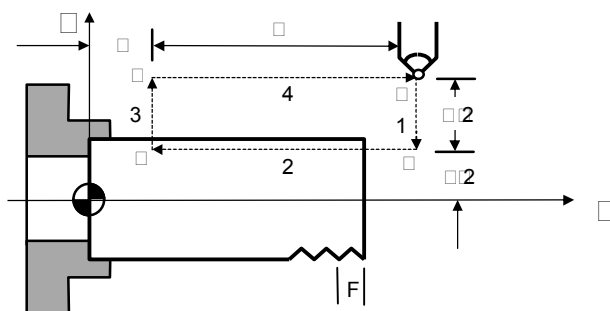

Fig. 3-27 G92 Linear Thread Cutting Canned Cycle

Details

- (1) The range of the thread lead and the speed limit of the spindle are same as G32 (thread cutting).
- (2) Whenever the start button (CYCST) is pressed in a block, the tool moves along the paths 1~2~3~4 to execute a cutting cycle.
- (3) Subject to the restrictions of G32.
- (4) Where a feed hold command is given during the cutting, the linear thread cutting canned cycle does not stop until the cutting on path 3 is complete.

Tapered Thread Cutting Canned Cycle

Format

G92 X(U) _____ Z(W) _____ R _____ L ___ Q ___ F _____ E _____

R : The difference between point B and C in radius.

X, Z, U, W, L, Q, F, E are identical to those of the linear thread cutting canned cycle.

Description of the tapered thread cutting is identical to linear thread cutting.

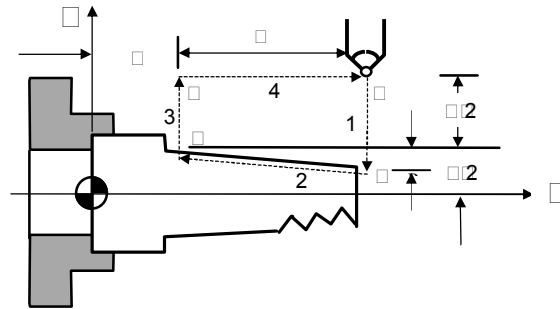

Fig. 3-28 G92 Tapered Thread Cutting Canned Cycle

Face Cutting Fixed Cycle

Format:

```
G94 X(U)___ Z(W)___ F___
```

X, Z : End point C in absolute coordinates.

U, W : End point C in incremental coordinates relative to the start point A.

F : B~C~D feed-rate.

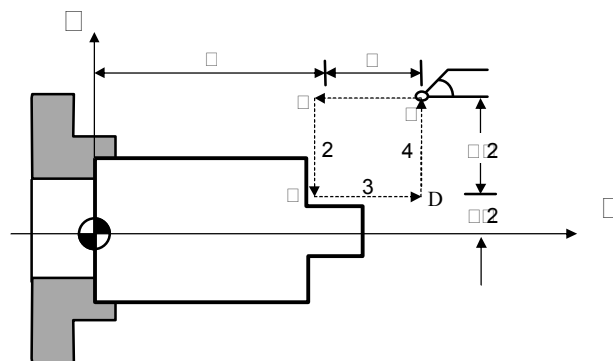

Fig. 3-29 G94 Linear Traversed Cutting Path

In Fig. 3-27, the cutting paths 1 and 4 are fast positioned by G00. The cutting along paths 2 and 3 is executed at the feed-rate F. Whenever the start button (CYCST) is pressed in a block, the tool moves along the paths 1~2~3~4 to execute a cutting cycle.

6 **Face Cutting Fixed Cycle**

Format:

G94 X(U)___ Z(W)___ R___ F___

R : The difference between point B and C in radius.

X, Z, U, W and F are identical to those of the linear traversed canned cycle.

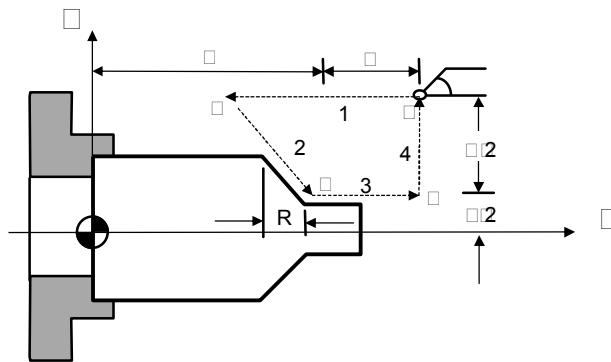

Fig. 3-30 G94 Tapered Traversed Cutting Path

When using incremental coordinates, the signs (+/-) of U and W are determined by the tool's moving directions. If the moving direction is positive, the increment of U and W is (+), and vice versa. R value is as Fig. 3-31.

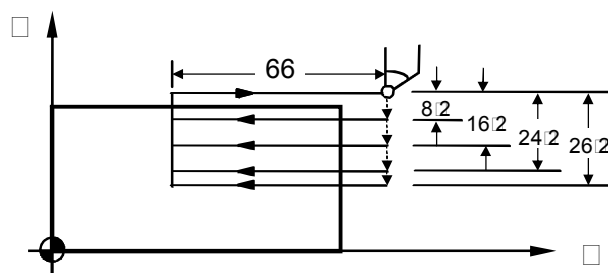

Fig. 3-31 G94 cutting Path and Direction

Note that G90, G94, G92 are modal codes and all the values for X(U), Z(W) and R remain valid unless they are redefined or another G-command is given.

As shown in Fig. 3-32, if the length of movement on Z-axis is fixed, the canned cycle is repeated merely by executing the X-axis positioning command.

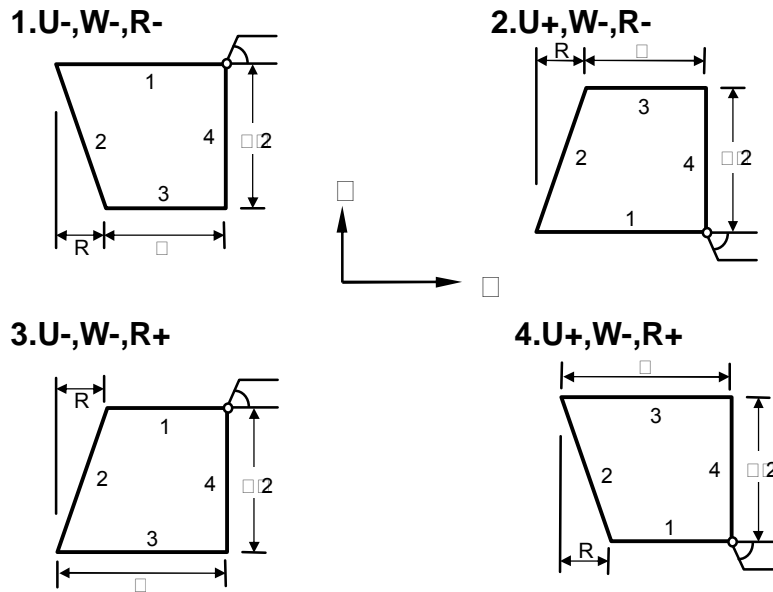

Fig 3-32 G90 Programming Example

```

N10 G0 X80.0 Z100.0
N20 M3 S2000
N30 G90 U-8.0 W-66.0 F2.00
N40 U-16.0
N50 U-24.0
N60 G0 U-26.0
N70 G1 W-66.0 F1.00      · · · Finishing cut with G01
N80 U2.0
N90 G0 X80.0 Z100.0
N100 M5
N110 M2
    
```

1.2 Compound Canned Cycle Functions

Compound canned cycles simplifies the operation of CNC commands, once the data of a work-piece is set for fine cut, the CNC automatically determines the tool path for the rough cut. Compound canned cycles are also used for thread cutting. This function is particularly suited for column cutting.

1 Finishing Cycle

Functions and Purposes

After a work-piece undergoes rough cut with G71, G72 or G73, G70 is used for fine cut of the work-piece to ensure its precision.

Format

G70 P(ns)____ Q(nf)____

P(ns) : The number of the first block for a fine cut cycle.

Q(nf) : The number of the last block for a fine cut cycle.

Details

- (1) The F, S, and T functions of G71, G72, G73 and previous blocks are applicable to G70. wherer F, S, or T is changed in the blocked from P(ns) to Q(nf), the changed values praveil.
- (2) When G70 is executed, the tool returns to the start point and reads the next block.

2 Longitudinal Touch Cutting Cycle

Format

G71 U(Δ d)____ R(e)____

G71 P(ns)____ Q(nf)____ U(Δ u)____ W(Δ w)____ F(f)____ S(s)____ T(t)____

N(ns)

.

.

N(nf)

G00 X__ Z__ ;Tool move back

Txxxx ;Change tool (fine cutting)

G00 X__ Z__ ;Move to the start position of Canned Cycle

G70 P(ns) Q(nf) ;Fine cutting

Parameters

In Fig. 3-33, the fine cut path is A~A1~B. A~C is the distance reserved for fine cut tool retraction. The cutting depth is $U(\Delta d)$. The amount of the material to be removed for fine cutting is $(\Delta u, \Delta w)$. The amount of retraction after each cut is $R(e)$. The path of the final rough cut is parallel to the path of the fine cut. The definition of command groups in the program format is described below:

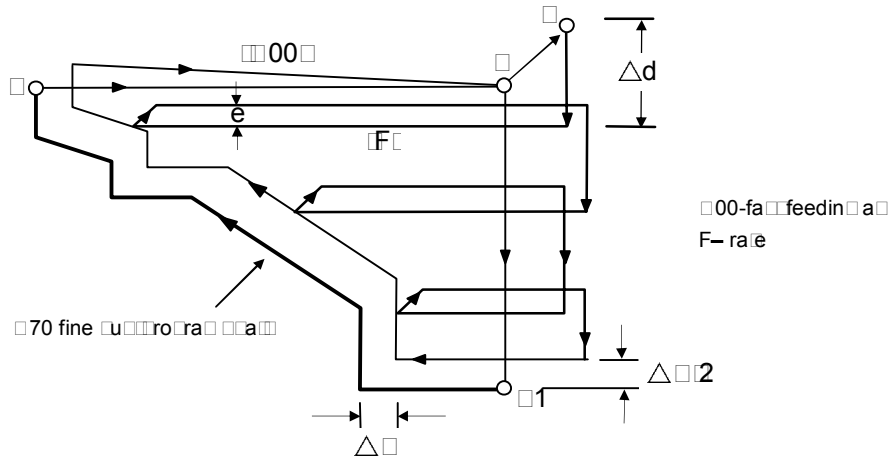

Fig. 3-33 Tool Path of G71 Rough Cut Canned Cycle

- $U(\Delta d)$: Cutting depth (radius programming, +).
 If not specified, the parameter "**G01 G02 Feedin amount**" is used.
- $R(e)$: Amount of retraction after each rough cut (radius programming).
 If not specified, the parameter "**G01 G02 Retraction amount**" is used.
- $P(ns)$: The number of the first block for a fine cut cycle.
- $Q(nf)$: The number of the last block for a fine cut cycle.
- $U(\Delta u)$: Amount of material to be removed for fine cut, X-axis.
- $W(\Delta w)$: Amount of material to be removed for final cut, Z-axis.
- $F(f), S(s), T(t)$: F = feed-rate. S = spindle speed, T = tool selection.
 The F, S, and T functions of G71 and previous blocks are applicable to G71, but all F, S, and T functions from N(ns) to N(nf) are not applicable to G71. They are only applicable to the fine cut command G70.

Details:

- (1) N(ns)~N(nf) specify the machining path of A1~B.
- (2) A maximum of 50 blocks can be inserted from N(ns) to N(nf).
- (3) No subprogram is available from N(ns) to N(nf).
- (4) No assignment of positioning commands on Z-axis is allowed from A to A1.
- (5) The feed-rate from A to A1 is either G00 or G01.
- (6) The X and Z tool path from A1 to B must be incremental or decremental.
- (7) The cutting depth U(Δ d) and retraction amount of rough cut R(e) are modal codes. They remain valid until another value is specified.
- (8) G71 is applicable to the following four cutting types. They are all parallel to the Z-axis. Whether U and W are positive or negative (Fig. 3-34) is determined by the direction of tool path.

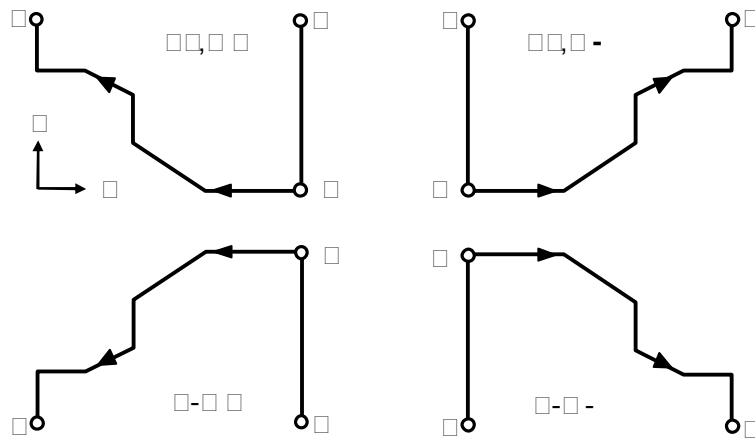

Fig. 3-34 G71 Rough Cut Canned Cycle

Programming Example of G70, G71 Compound Canned Cycle

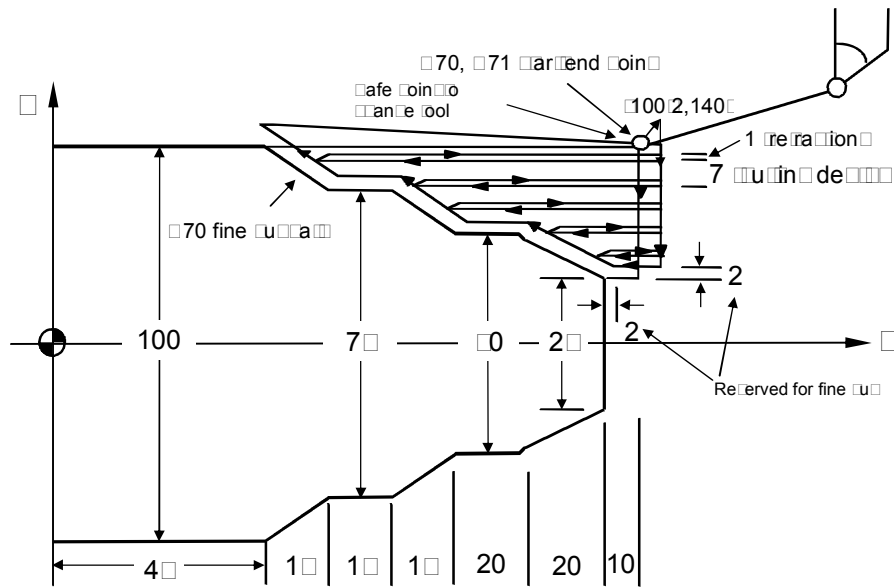

Fig. 3-35 Programming Example of G71, G70 Compound Canned Cycle

```

G28 W0.
T0202
M3 S3000
G00 X100.000
Z140.000
G71 U7.000 R1.000
G71 P100 Q200 U4.000 W2.000 F2.00
N100 G01 X25.0 F1.50
W-10.000
X50.000 W-20.000
W-20.000
X75.000 W-15.000
W-15.000
N200 X100.000 W-15.000
G00 X110.
Z150.
T0303
G00 X100.
Z140.
G70 P100 Q200
    
```

M05 S0

M30

Face Rough Cutting Cycle

Functions and Purposes

Calls a forming program and calculates tool path automatically while executing a transversed rough cutting.

Format

```

G72 W( $\Delta d$ ) ___ R(e) ___
G72 P(ns)___ Q(nf)___ U( $\Delta u$ )___ W( $\Delta w$ )___ F(f)___ S(s)___ T(t)___

N(ns) . . . . .
      . . . . .
      . . . . .

N(nf) . . . . .

G00 X___ Z___           ;Tool move back
Txxxx                   ;Change tool (fine cutting)
G00 X___ Z___           ;Move to the start position of Canned Cycle
G70 P(ns) Q(nf)         ;Fine cutting
    
```

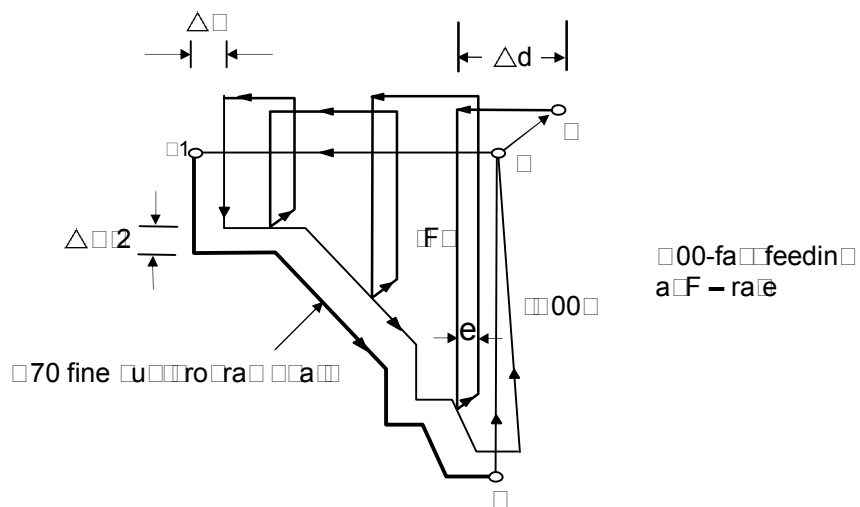

Fig. 3-36 Cutting Path of G72 Compound Canned Cycle

As shown in Fig. 3-36, all functions of G72 are same as G71, except that the cycle path is parallel to the X-axis.

Details □

- (1) N(ns)~N(nf) define the machining path of A1~B.
- (2) No assignment of positioning commands on X-axis is allowed from A to A1.
- (3) The feed-rate from A to A1 is either G00 or G01.
- (4) The X and Z tool path from A1 to B must be incremental or decremental.
- (5) No subprogram is available from N(ns) to N(nf).
- (6) G72 is applicable to the following four cutting types. They are all parallel to X-axis. Whether U and W are positive or negative (Fig. 3-37) is determined by the direction of tool path.

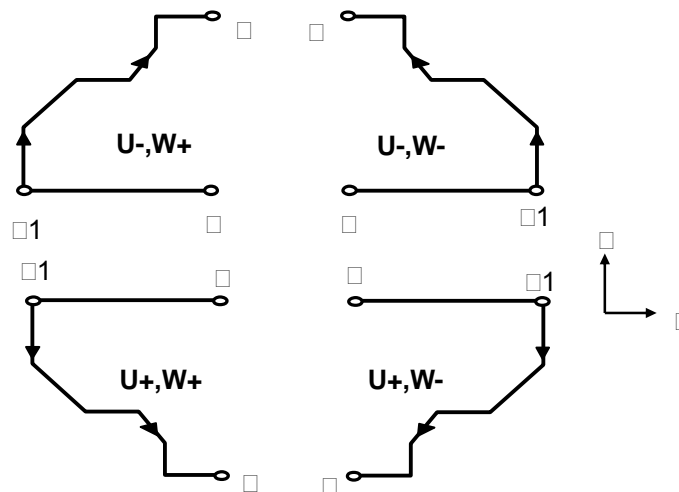

Fig. 3-37 Cutting Path of G72 Compound Canned cycle

Example : 2 pound canned cycles

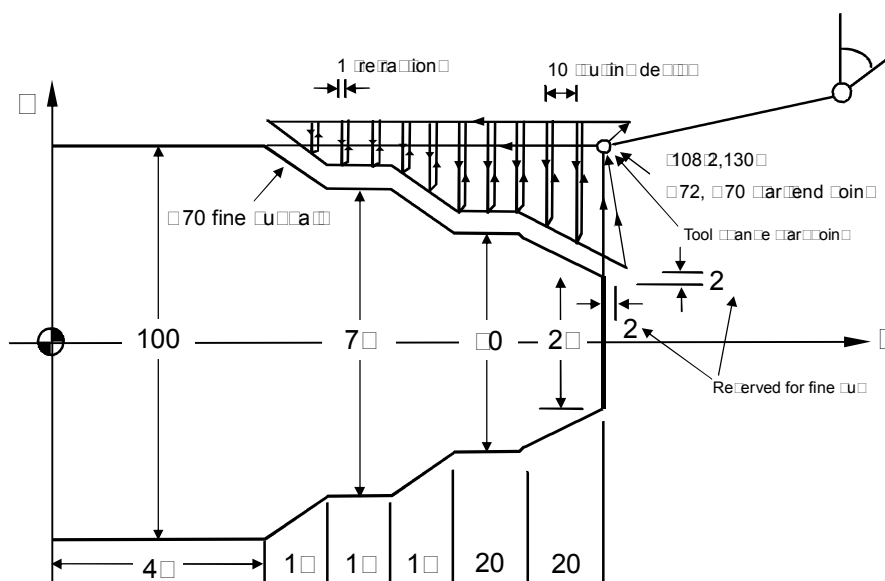

Fig. 3-38 Programming Example of G72, G70 Compound Canned Cycles

```

G28 W0.
T0202
M3 S2000
G00 X108.000 Z130.000
G72 W10.000 R1.000
G72 P100 Q200 U4.0 W2.0 F3.00
N100 G00 Z45.000
G01 X75.000 W15.000 F1.50
W15.000
X50.000 W15.000
W20.000
N200 X25.000 W20.000
G00 X110.
Z140.
T0303
G00 X108.
Z130.
G70 P100 Q200
M05 S0
M30
    
```

Forced Material Rough Cutting Cycle

Functions and Purposes

To save machining time, G73 is used to cut a work-piece that has been machined in a rough cut, forging or casting process and formed with a shape similar to the finished-product.

Format:

G73 U(Δ i)___ W(Δ k)___ R(d)___

G73 P(ns)___ Q(nf)___ U(Δ u)___ W(Δ w)___ F(f)___ S(s)___ T(t)___

N(ns)

N(nf)

G00 X___ Z___ ;Tool move back

Txxxx ;Change tool (fine cutting)

G00 X___ Z___ ;Move to the start position of Canned Cycle

G70 P(ns) Q(nf) --- ;Fine cutting

Parameters

U(Δ i) : Cutting amount on X-axis. (radius programming)

 If not defined, the parameter "**Total Cutting Amount**" is used.

W(Δ k) : Cutting amount on Z-axis.

 If not defined, the parameter "**Total Cutting Amount**" is used.

R(d) : Rough Cutting Cycles

 I.e. times of cuts required to reach the defined cutting depth on X and Z-axes. If not defined, the parameter "**Cutting Cycles**" is used.

P(ns) : The first block number of a fine cut cycle.

Q(nf) : The last block number of a fine cut cycle.

U(Δ u) : Amount of material to be removed for fine cut, X-axis.

$W(\Delta w)$: Amount of material to be removed for final cut, Z-axis.

$F(f), S(s), T(t)$: F = feed-rate, S = spindle speed, T = tool selection.

The F, S, and T functions of G73 and previous blocks are applicable to G73, but all F, S, and T functions from N(ns) to N(nf) are not applicable to G73. They are only applicable to the fine cut command G70.

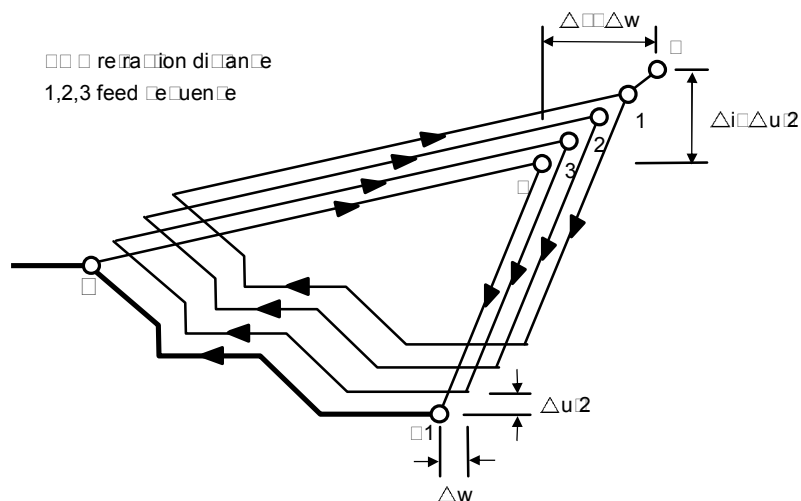

Fig. 3-39 Cutting Path of G73 Compound Canned Cycle

Details

- (1) N(ns)~N(nf) define the machining path of A←A1←B.
- (2) A maximum of 50 blocks can be inserted from N(ns) to N(nf).
- (3) No subprogram is available from N(ns) to N(nf).
- (4) The tool returns to A when the cycle finishes.
- (5) The cutting amount $U(\Delta u, \Delta k)$ and the cutting cycles $R(d)$ are modal codes. They remain valid until another value is defined.

Face Cut-Off Cycle

Functions and Purposes

G74 command automatically performs a fixed loop at the end of the workpiece via commands such as coordinate of groove end, cutting depth, tool retract depth etc.

Format:

G74 R(e)___

G74 X(U)___ Z(W)___ P Δ i___ Q Δ k___ R Δ d___ F___

R(e) : Amount the tool move backward when after Z cutting Δ k

X : Absolute positioning command on X-axis

Z : Absolute positioning command on Z-axis

U : Incremental positioning command on X-axis

W : Incremental coordinates on Z-axis

P Δ i : Amount the each movement of X canned cycle.

Q Δ k : Z cutting of the each segment

R Δ d : Amount the tool move backward when X end of cutting

F : Cutting speed feed-rate

- (1) Input of a Z or W parameter is a must
- (2) IF R (e) tool extraction parameter is not given, tool extraction depth shall be set using the setting of parameter G74 or G75.
- (3) Total cutting distance must be greater than respective cutting distances.

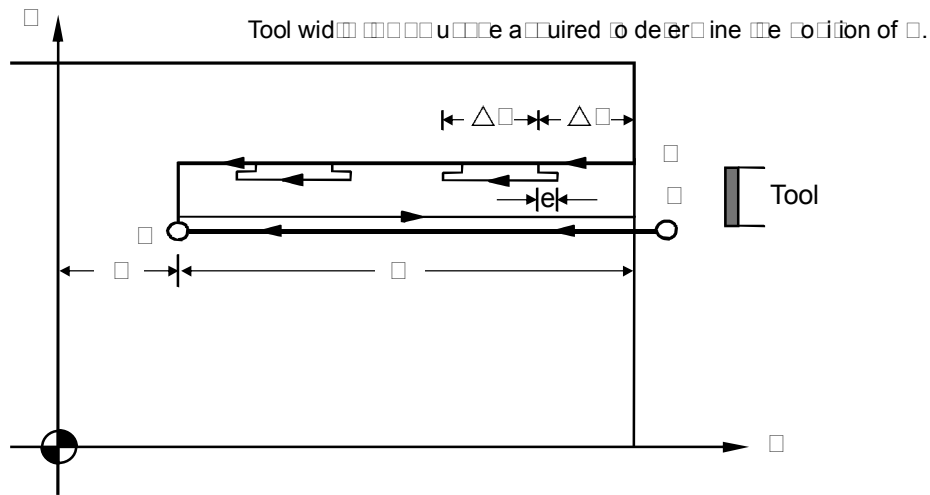

Fig 3-41 Cutting Path of G74 Lateral Grooving Canned Cycle

Axial drilling can be performed when the X axis is at X=0 position.

Example 1 without tool feed in the X direction

- G0 X0. Z80. ⇒ Move tool quickly to the position X0. Z80. is relative to the work origin.
- M03 S2000 ⇒ Positive rotation of spindle, speed 2000(rpm).
- G74 R3. ⇒ R3. stands for a tool retraction of 3000(μm) after each drilling depth of 10000(μm).
- G74 Z30.K10.R3.F0.2 ⇒ Drilling canned cycle: "Z30" indicates that the drilling cycle ends at the absolute coordinate Z30. K10 indicates 10,000 (μm) per drilling. R3 indicates 3000 (μm) per retraction.
- M05 S0 ⇒ Spindle stops.
- M02 ⇒ Program ends.

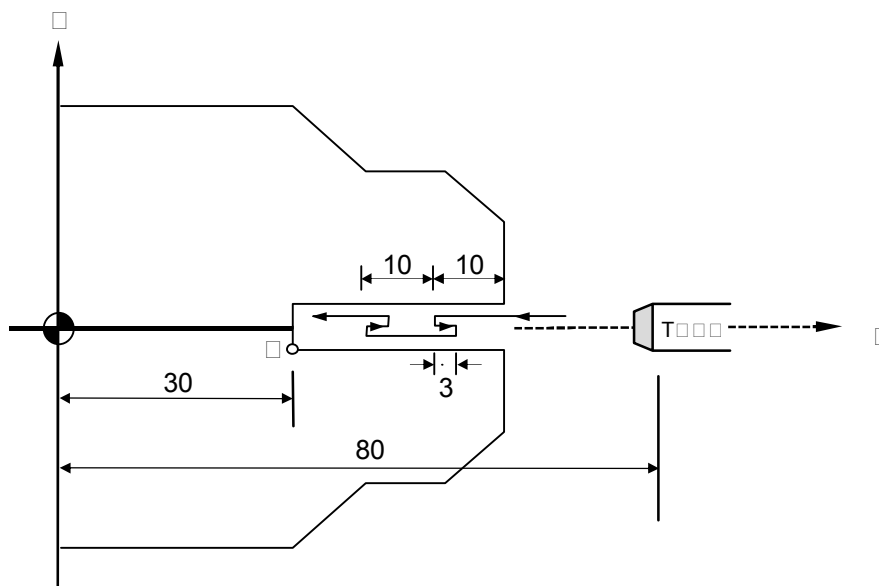

Fig. 3-42

Example 2 with tool feed in the X direction

G0 X0. Z80. ⇒ Move tool quickly to the position X0. Z80. is relative to the work origin.

M03 S2000 ⇒ Positive rotation of spindle, speed 2000(rpm).

G74 R3. ⇒ R3. stands for a tool retraction of 3000(μm) after each drilling depth of 10000(μm)

G74 X2.Z30.P400 Q10000 R1. F0.5 ⇒

Grooving canned cycle: “Z30.” Indicates the drilling cycle ends at absolute coordinate 30. in the Z-direction; “X2.” Indicates the end coordinates of cycling movements in the X-direction are: 2.; “P400” indicates a 200 (μm) movement per cycle in the X-direction; Q10000 indicates 10000(μm) per drilling; “R1.” Indicates tool retraction of 500(μm) in the X-direction when the cutting reaches end position. (Diameter specification)

M05 S0 ⇒ Spindle stops.

M02 ⇒ Program ends.

6 Longitudinal Cut-Off Cycle

Functions and Purposes

The G75 function is the same as G74 except that the positioning direction of G75 is on the X-axis.

Format

G75 R(e)____
 G75 X(U)____ Z(W)____ P△i____ Q△k____ R△d ____ F

Parameters

- R(e) : Amount the tool move backward when after X cutting △I. (Diameter specification)
- X : Absolute positioning command on X-axis
- Z : Absolute positioning command on Z-axis
- U : Incremental positioning command on X-axis
- W : Incremental coordinates on Z-axis
- P△i : Amount the each movement of X canned cycle. (Diameter specification)
- Q△k : Z cutting of the each segment (Integer μm specification)
- R△d : Amount the tool move backward when Z end of cutting (Integer μm specification)
- F : Cutting speed feed-rate

Details

1. Input of a Z or W parameter is a must
2. IF R (e) tool extraction parameter is not given, tool extraction depth shall be set using the setting of parameter G74 or G75.
3. Total cutting distance must be greater than respective cutting distances.

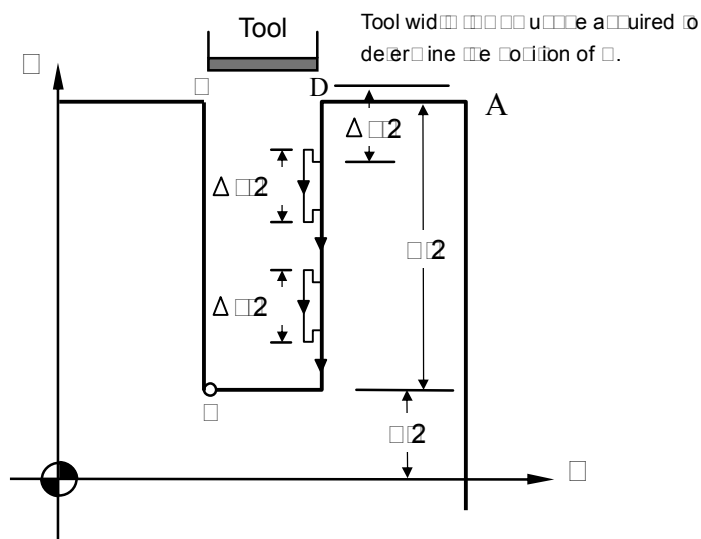

Fig. 3-43 Cutting Path of G75 Traverse Grooving Canned Cycle

Example 1 without tool feed in the Z direction

- N10 G0 X80.0 Z0.0 ⇒ Moves tool quickly to the home position of workpiece X80. Z0.
- N20 M03 S2000 ⇒ Spindle CW, speed 2000(rpm).
- N30 G75 R1. ⇒ R1. indicates a 500(μ m) tool retraction after each drilling depth of 2500(μ m).
- N40 G75 X60. P5. F0.5 ⇒ Drilling cycle: "Z60." Indicates end of drilling cycle is at absolute coordinate 60. in the Z-direction. P5. stands for 2500 (μ m) per drilling. (Diameter specification)
- N50 M5 S0 ⇒ Spindle stops.
- N60 M2 ⇒ End of program.

Example 2 with tool feed in Z direction

- N10 G0 X80.0 Z0.0 ⇒ Quickly move tool to X80. Z0 position relative to the work origin
- N20 M03 S2000 ⇒ Positive rotation of spindle, speed 2000(rpm).
- N30 G75 R2. ⇒ R2. stands for a tool retraction of 1000(μ m) after each drilling depth of 2500 (μ m).
- N40 G75 X60.Z3.P5. Q500 R1.F0.5

⇒ Groove cutting cycle: “X60.” indicating drilling cycle ends at the absolute coordinate X60. “Z3.” Indicates that the cycle ends at coordinate Z3. “P5.” stands for a drilling depth of 2500 (μm) for each drilling cycle. Q0.5 stands for Z-direction movement per cycle is 500 (μm). “R1.” indicates tool retraction of 1000 (μm) in Z-direction after reaching the end position. (diameter specification)

N50 M5 S0 ⇒ Spindle stop.
 N60 M2 ⇒ end of program.

Compound Thread Cutting Canned Cycle

Functions and Purposes

G76 specifies the start point and end point of a thread cutting. This command can be entered at any angle. A fixed number of loops are cut for every cycle with the same cross-section. Thread end point coordinate and specification of slanting height are considered. It is also capable of performing thread cutting in various directions.

Format

G76 P(m)(r)(a)___ Q(Δ d min)___ R(d)___
 G76 X(U)___ Z(W)___ R(i)___ P(k)___ Q(Δ d)___ F(l)___ E___

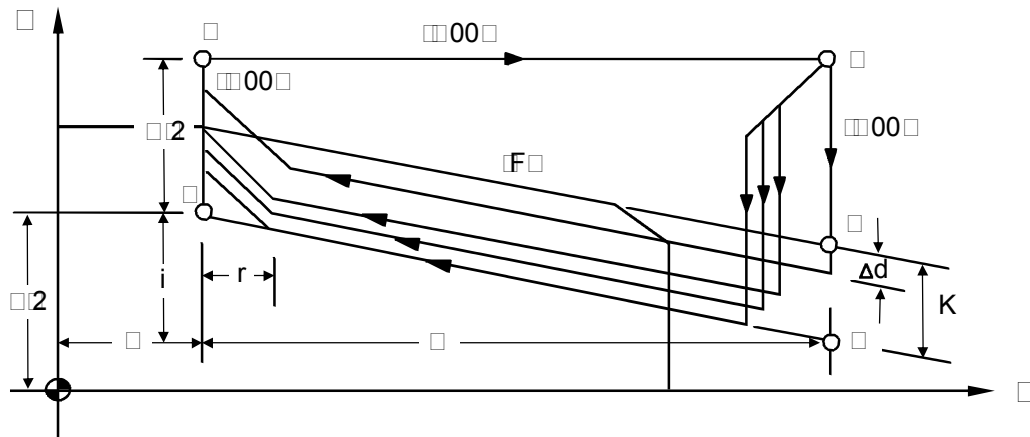

Fig. 3-44 G76 Compound Thread Cutting Canned Cycle

Parameters

- m : Fine cut times (2-digit, 01~99)
If not defined, parameter "G6 Fine Cut Times" is used.
- r : Chamfering settings (2 digits)
Length of chamfering = $0.1 \times \text{chamfering settings (r)} \times \text{thread pitch}$. If not defined, the parameter "Chamfering Settings" is used.
- a : Tool-tip angle (0° - 90°).
The available angles are $0^\circ, 5^\circ, 10^\circ, 15^\circ, \dots$ to 90° . If not defined, the parameter "Tool-tip Angle" is used.

m, r, and a are defined simultaneously by the command code P.

For $m=2, r=12, a=60^\circ$, then the command is G76 P021260.

Q(Δd min): Minimum cutting amount (integer μm)

When the cutting amount of the nth cutting ($\Delta d\sqrt{n} - \Delta d\sqrt{n-1}$) $< \Delta d$ min, the cutting will resume with Δd min as the minimum cutting amount. If no minimum cutting amount is defined, the parameter "Minimum Cutting Depth" is used.

- R(d) : Amount of material to be removed for the fine cut
If not defined, the parameter "Residual Thread Depth" is used.
- X, Z : Absolute coordinates of cutting end point (D).
- U, W : Incremental coordinates of the cutting end point (D).
- R(i) : Radius difference of thread part (i=0 indicates normal linear thread cutting).
- P(k) : Thread height (radius programming on X-axis, unit: integer μm)
- Q(Δd) : First cutting depth (radius programming, unit: integer μm)
- F(l) : Thread pitch, (same as G32)
- E : Number of threads per inch; range: 1.0-100.0. This setting shall not appear when an F setting is given.

Details of G76

- (1) What must be noted is that length of the path DE (U/2) must be greater than the length of the chamfer.

- (2) The fine cut times m , chamfering settings r , tool-tip angle a , minimum cutting amount Q (Δd_{min}) and reserved thread depth $R(d)$ are modal codes. They remain valid until another value is defined.
- (3) The feed-rate between C and D is defined by F and fast feeding is applied to other paths. The (+)(-) values of the increments in Fig. 3-39 are as follows:

U, W : Negative (determined by the directions of AC and CD).
 R : Negative (determined by the directions of AC).

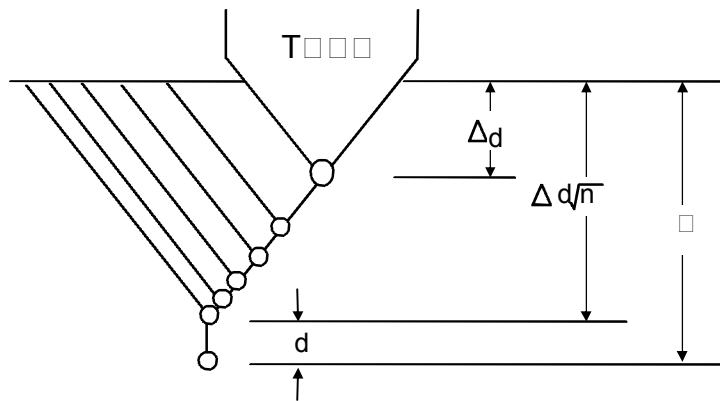

Fig. 3-45 Cutting Description

- (4) The thread height K is acquired from the thread pitch and the tool nose angle. The formula is:

$$\text{Thread height } k = (\text{pitch}/2) / \tan(\text{angle}/2)$$

$\tan(\text{angle}/2)$, acquired from the trigonometric table.

Ex: If tool nose angle $a=60^\circ$, Thread pitch $F(1)=2$ mm.

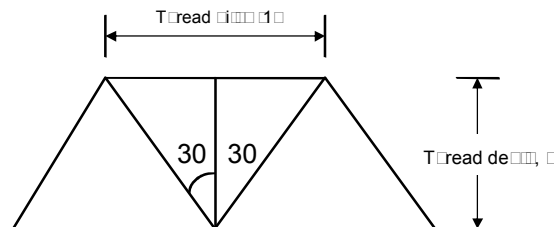

Fig. 3-46

$$\begin{aligned} \text{Thread height } k &= (2/2) / \tan(60/2) \\ &= (1) / \tan 30 = (1)/0.5774 = 1.732 \end{aligned}$$

The first cutting depth (cutting amount) is Δd , the n^{th} cutting depth is $\Delta d\sqrt{n}$, the cutting amount will decrease progressively every time. Note that n should not exceed 30. Otherwise, an alarm will be generated. In this case, please use the normal thread cutting.

Example :

If tool nose angle $\alpha=60^\circ$, Thread pitch $F (l)=2$ mm.

as shown in the above example, thread height $k= 1.732$

$$X = 20 - 2 \times 1.732 = 16.536$$

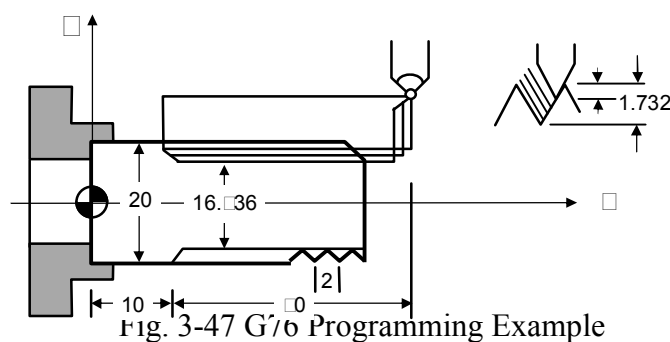

```

N10 G0 X30.0 Z60.0
N20 M03 S2000
N30 G76 P011060 Q100 R0.200
N40 G76 X16.536 Z10.000 P1732 Q900 F2.00
N50 M05
N60 M02

```

Notes on thread cutting are identical to G32 and G92. The chamfering settings are also applicable to G92 thread cutting canned cycle.

Notes on Compound Canned Cycle

- Every command of a compound canned cycle must contain correct P, Q, X, Z, U, W and R values.
- In G71, G72, G73 blocks, the block defined by P must contain either G00 or G01. Otherwise, alarm will be generated.
- G70, G71, G72, and G73 are not allowed in MDI mode. Otherwise, an alarm is triggered.

- In G70, G71, G72, or G73, no M98 (call subprograms) and M99 (quit subprograms) are applicable to blocks defined by P and Q.
- When executing G70~G73, the serial numbers defined by P and Q should not be the same.
- In G70, G71, G72, and G73, chamfering and R angle should not be used to terminate the last positioning command used for fine cut shaping blocks defined by P and Q.

G50 Coordinate system spindle speed setting

1. **The setting function for the maximum spindle speed normally does not work with the setting function of the constant surface cutting mode.**

For example:

G50 S_____

S : Max. spindle speed (rpm or rev/min)

2. **Work coordinate offset function For continuous process of multiple workpieces or origin can be set via continuous offset setting of tool start point**

For example:

(1) G50 U _____ (X -direction offset) °

(2) G50 W _____ (Z -direction offset) °

Example :

O001 (Main program number)

N10 G10 P500 A1 B0 (X -direction work coordinate offset clearing)

N20 G10 P500 A3 B0 (Z -direction work coordinate offset clearing)

N30 T01

N40 M98 P02 L5 (Call for O002 subprogram, successively for 5 times)

N50 M99

O02 (number of subprogram)

N1 G50 W10. (10mm offset of tool start point each for every time)

N2 G01 U-10.

N3 G00 U10.

N2 M99

Description

- (1) Please give “G10 P500 A1 B0”, and “G10 P500 A3 B0” at the beginning of program.
- (2) The “L suffix” of an M98 command indicates number of offsets to be performed. (See description of M98 command).

1 Constant Surface Speed Control ON 6

For at:

G96 S_____

S : Surface cutting speed (m/min)

The surface cutting speed refers to the relative velocity between the tool-tip and cutting point (on the surface) of the rotating work-piece. A tool has its advised surface cutting speed range for optimizing the cutting result. G96 is used to control the surface cutting speed. The relationship between the surface cutting speed, work-piece diameter and spindle rotation speed is expressed by:

$$V = \pi DN$$

V : The surface cutting speed is the S value of G96.

D : Diameter of the surface is sut, m.

N : Spindle rotation speed, rev/min.

When the surface cutting speed is constant and the tool cuts the surface inwards, D will become lesser and N will become greater. Hence the max. rotation speed must be limited using G50 S___. Once this limit is reached, the speed will not increase any more.

Ex: N10 G50 S2000 · · · Max. rotation speed of the spindle is 2000 rpm.
 N20 G96 S200 · · · The constant surface cutting speed is 200 m/min.

02 Constant Surface Speed Control OFF

Format:

G97 S_____

This function maintains the spindle speed defined by S. It cancels the constant surface cutting speed at the same time.

01 Feed-rate Setting

G98 : Feed per minute, mm/min
 G99 : Feed per revolution, mm/rev

The feed-rate F in H6D-T turner series is defined by G98 and G99. G99 is the default value. The conversion formula is:

$$F_m = F_r * S$$

Fm : Feed per minute, mm/min.
 Fr : Feed per revolution, mm/rev.
 S : Spindle speed, rev/min.

02 Inch/Metric Measurement Mode 020001

Format

G20 -- System measurement in INCH mode
 G21 -- System measurement in METRIC mode

2 Deep Hole Drilling Cycle

Format

G83 Z(W)___ Q___ R___ F___ ; Deep hole drilling cycle
 G80 ; Fixed cycle for drilling cancel

Parameters

- Z(W) : Point the hole position with absolute or increment
- Q : Each depth of drilling (Unit: μm , Q10000=10mm)
 ※ If Q with no values that drilling motion will finish one time.
- R : Point of reference with go forward or move backward
 ※ Absolute position
 ※ If R with no values that it will according to now Z coordinates be R values.
- F : Drilling speed feed-rate (mm/rev)

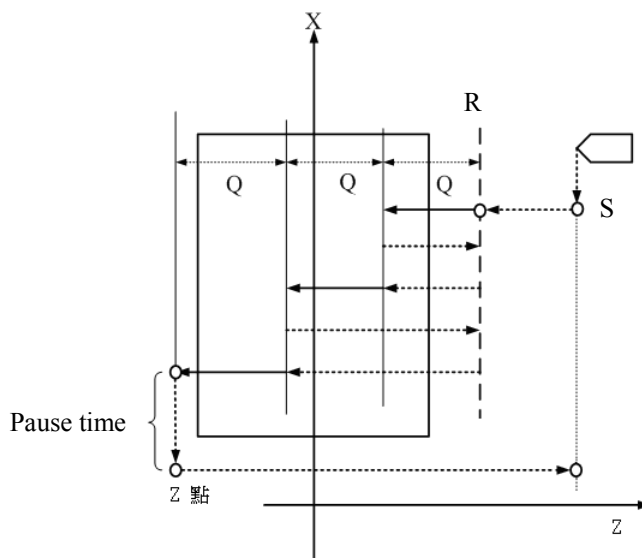

Fig 3-48 G83 Drilling

2 Tapping Cycle

G80 : Fixed cycle for drilling cancel

G84 : Tapping cycle

For at

G84 X(U) Z(W)___ Q___ R___ F___ D___

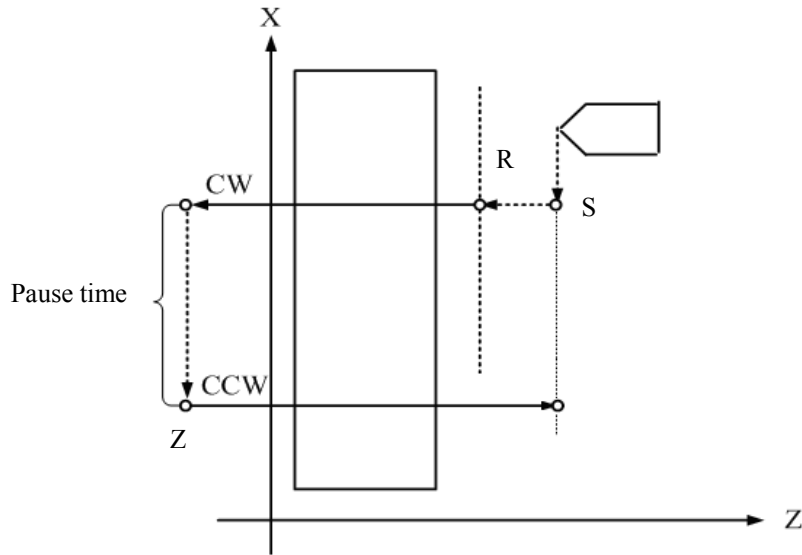

Fig 3-49 G84 Threading

1 Parameters

Z(W) : Point the hole position with absolute or increment (**direction**)

R : Point of reference with go forward or move backward

※ Absolute position

※ If R with no values that it will according to now Z coordinates be R values.

Q : Each depth of tap cutting (Unit: μm , Q10000=10mm)

※ If Q with no values that tapping motion will finish one time.

F : Set the spacing thread pitch of the tapping tools (F1.0=1mm)

D : First spindle end face threading if D parameter is not specified.

2 Parameters F D1

(1) X(U) : Position of hole bottom is specified by an absolute or incremental value (X-direction)

(2) D=1 : Threading of second spindle lateral face

(3) Other parameters are the same as above

□□ □□□□□□ □□ □□ □□□□**F□□ D2**

- (1) Z (W) : Position of hole bottom is specified by an absolute or incremental value (Z-direction)
- (2) D=2 : Threading of third spindle end face
- (3) Other parameters are the same as above

G84 and G80 are used in pairs. If G80 is missing, program will report an Err18.

□□ □-**a**is appli□ation e□a□ple□

```

N10 M70 ( third spindle switched as servo-spindle mode )
N20 T1
N30 G0 X-20.C0.
N40 Z3.
N50 G84 Z-20.F1.R2.D2
N60 C60.
N70 C120.
N80 G80
N90 M71 ( third spindle switched back to main spindle mode )
N100G0 Z20.
N110 M2

```

□□ □-**a**is appli□ation e□a□ple□

```

N10 M60 ( Second spindle switched as servo-spindle mode )
N20 T1
N30 G0X5.C0.
N40 Z3.
N50 G84U-10.F1.R4.D1
N60 C60.
N70 C120.
N80 G80
N90 M61 ( Second spindle switched back to spindle mode )
N100 M02

```

2 Auxiliary Functions M-code Code

The auxiliary function M-code is comprised of the letter M and 2 digits attached behind (M-codes for general), different codes represents different functions as shown below:
 Currently, H6D-T Series provides the following M-codes:

Table 3-10

| M-CODE | Function |
|--------|--|
| M00 | Program Suspension. |
| M01 | Selective stop |
| M02 | Program End. |
| M03 | Spindle rotates in normal direction |
| M04 | Spindle rotates in reversed direction |
| M05 | Spindle stops |
| M08 | Coolant ON. |
| M09 | Coolant OFF. |
| M10 | Spindle chuck tightened |
| M11 | Spindle chuck loosened |
| M12 | Tailstock forward |
| M13 | Tailstock backward |
| M15 | Count plus 1 |
| M16 | Count clear (to zero) |
| M30 | Program end |
| M33 | Workpiece Collector Protrude |
| M34 | Workpiece Collector Extract |
| M35 | Tailstock Chuck Clamp |
| M36 | Tailstock Chuck Release |
| M40 | Chip Remove CW |
| M41 | Chip Remove CCW |
| M42 | Chip Remove Stop |
| M43 | Feeder Start |
| M45 | Select Skip Start |
| M46 | Select Skip Close |
| M47 | The Spindle should rotate after releasing the Chuck |
| M48 | When releasing the Chuck, prohibit the spindle rotation. |

| M-CODE | Function |
|--------|--|
| | . |
| M50 | Set Spindle 1 to Servo Axis Mode. |
| M51 | Set Spindle 1 back to Spindle Mode. |
| M55 | Start in-process Tool offset change instant avail. |
| M60 | Set Spindle 2 to Servo Axis Mode. |
| M61 | Set Spindle 2 back to Spindle Mode. |
| M63 | Spindle 2 CW |
| M64 | Spindle 2 CCW |
| M65 | Spindle 2 Stop |
| M70 | Set Spindle 3 to Servo Axis Mode. |
| M71 | Set Spindle 3 back to Spindle Mode. |
| M73 | Spindle 3 CW |
| M74 | Spindle 3 CCW |
| M75 | Spindle 3 Stop |
| M80 | Enable axial direction without homing |
| M81 | Disable axial direction without homing |
| M84 | Spindle brake hold |
| M85 | Spindle brake release |
| M98 | Call subprogram |
| M99 | Program cycle |
| M30 | Program end |
| M300 | Enable round-angle connection between blocks |
| M301 | Disable round-angle connection between blocks |
| M362 | Switch to Spindle 1 |
| M364 | Switch to Spindle 2 |
| M365 | Switch to Spindle 3 |

Using CW, CCW of spindle:

1. M03: First spindle clockwise (CW)

Format:

- (1) M03 SXXXX

EX.: M03 S1000 ; Command first spindle to rotate CW at 1000rpm.

- (2) M03

If M03 is not followed by an S-code, spindle rpm is not specified; spindle

will rotate CW at the previous speed.

2. M04: First spindle CCW

Format:

(1) M04 SXXXX

EX.: M04 S1000 ; Command first spindle to rotate CCW at 1000rpm

(2) M04

If M04 is not followed by an S-code, spindle rpm is not specified; spindle will rotate CCW at the previous speed.

The auxiliary function code S-code is for spindle rpm control, maximum setting range: S999999.

EX: S1000, means 1000 rpm

26 u pro ra

Where there are certain fixed programs or command groups in a main program that demand repeated execution, these commands could be saved in memory as subprograms, so that the main program could be designed with a simplified structure. Subprograms can be called out one after another in auto mode.

1 Structure of the u pro ra

The structure of the subprogram is the same as the main program except that the subprogram ends with an M99 command.

```

PROGRAM 05      · · · · · Subprogram number
                 · · · · · Content
                 · · · · · Content
M99              · · · · · Subprogram ends
    
```

If a subprogram is not called by the main program but executed directly by pressing “CYCST”, the program loops.

2 Execution of the u pro ra

Format:

M98 P _____ L _____

P : Subprogram number

L : Execution times of the subprogram. If not defined, the subprogram is to be executed only once.

Ex: M98 P05 Execute subprogram No 5 once.

M98 P05 L3 Execute subprogram No 5 three times.

Stepwise Call: the main program calls the first subprogram, and the first subprogram calls a second sub-prgrams. The H6D-T Series controller provides a maximum of 8 levels stepwise calls: (take for an example of 5 layers)

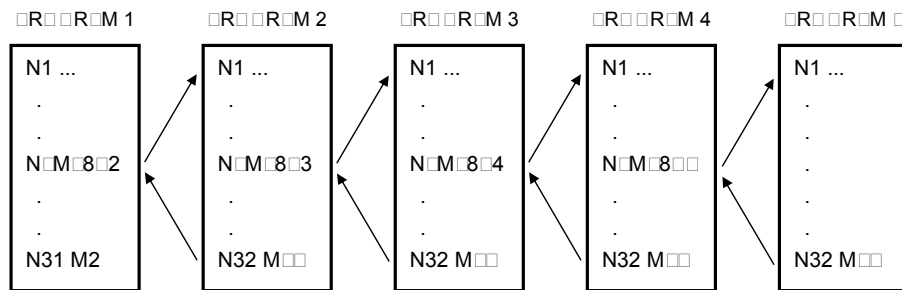

Fig. 3-50 Subprogram Stepwise Call

The M98 and M99 blocks should not contain any positioning commands, such as X..., Z... .

2 Tool Radius Compensation

2.1 Total Offset Compensation Setting and Cancellation

Total offset compensation = Length compensation + Wear compensation

Format:

Table 3-11

| | Compensation Set | Compensation Cancel |
|----------------|------------------|---------------------|
| Without Turret | T□□ | T00 |
| With Turret | T○○□□ | T○○00 |

- : Compensation number, indicating which set of compensation data is to be applied.
- : Tool number, indicating which tool is to be selected.

When a compensation number is selected, the control unit will simultaneously select the X-axis and Z-axis compensation values for tool length and wear compensation. These values are summed up for compensation of the tool path.

Any small differences between the cut work-piece and specifications found during the cutting test after the tool is calibrated, can be remedied by wear compensation (referring to the Tool Wear Compensation page). If the difference is very small, positive values should be used. If the difference is large, negative values should be used.

```
Ex: N10 G01 X50.000 Z100.000 T0202
     N20 Z200.000
     N30 X100.000 Z250.000 T0200
```

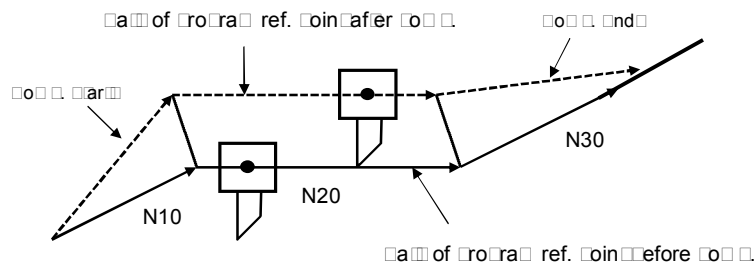

Fig. 3-51 Example of Tool Length Compensation

In this example, T0202(T202) indicates that the second tool and the second set of compensation data are selected. T0200 (or T200) indicates that the tool length compensation is cancelled.

Value of Compensation

1. Value of compensation is normally set by the last digit or the last 2 digits of a T-code. Once a T-code is specified, it remains effective until a subsequent specification is made. In addition to tool-tip compensation, a T-code can also be used for specifying tool-length compensation.
2. A change of compensation setting is usually made in compensation-disabled mode when selecting another tool. In the event a change is made during a compensation mode, the end vector of the program will be calculated according to the specified compensation value.

Notes:

1. After powering the CNC, compensation is automatically cancelled and the compensation number is reset to "0" or "00".
2. Compensation must be cancelled to execute "Auto-CYCST".
3. The length compensation command "T-code" can form an independent block in the program without positioning definition. CNC executes an internal computation for compensation, but the tool does not execute any positioning movement.

2.2 Tool-tip Radius and Direction of Filletious Tool-tip 1 2

Functions and Purposes

A tool tip is normally in an arc shape, therefore when a program is run, a tool tip is assumed to be the front end of the tool. In this sense, shape of an actual cutting will be different from the programmed cutting due to the arc-shaped tool tip. The Tool-tip Radius compensation is a function designed for automatically calculating an error for compensation via setting a tool-tip radius.

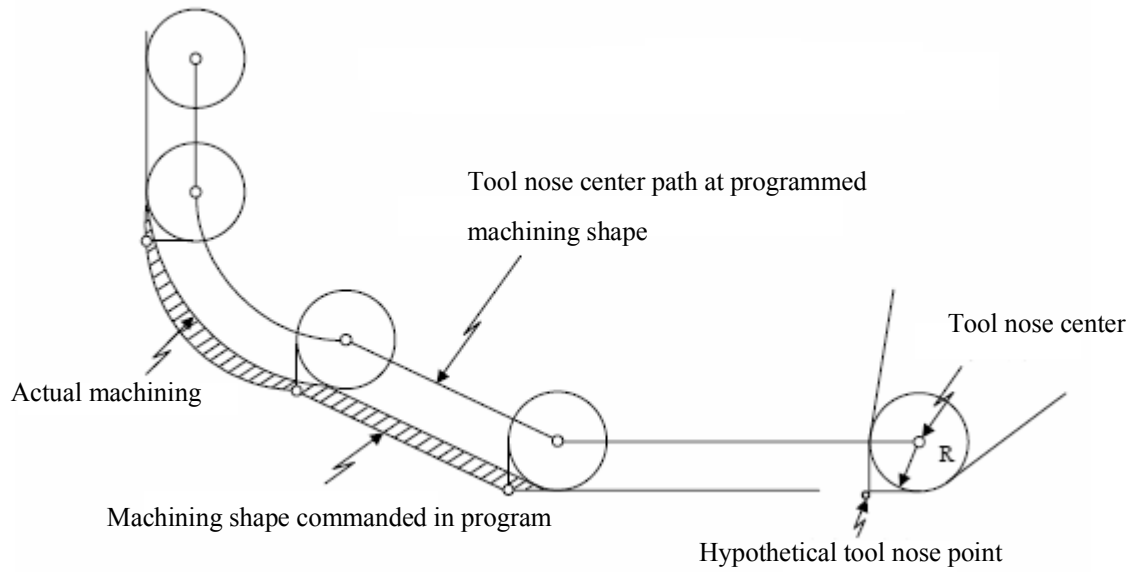

Fig 3-52

Program Format

- | | |
|-------------------------|---|
| T## or T### | Call a tool number for compensation |
| G41(G42) X(U)___Z(W)___ | Set compensation |
| G40 | Cancel compensation |

Before using G41 and G42, inform the NC unit which tool-no. is to be used. The application is totally dependent to the tool path and the relative position of the tool. As shown in Fig. 3-53, looking forward along the tool path, use G42 if the tool tip radius is on the right side of the tool path (radius right side offset compensation); use G41 if the tool tip radius is on the left side of the tool path (radius left side offset compensation)

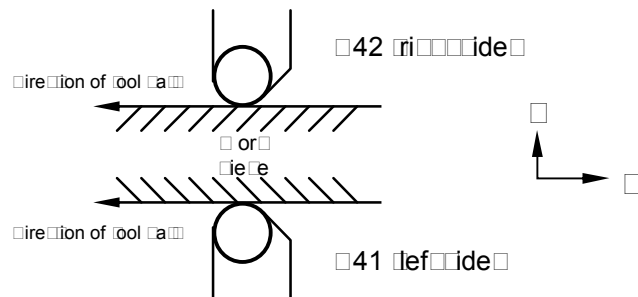

Fig 3-53 Application of G41 and G42

Tool-tip and assumed tool-tip direction

When executing tool-tip radius compensation, the radius and arc must be accurate; otherwise, the cutting result will not be precise. Manufacturers of disposable tools always provide accurate tool-tip radius data. The radius data are to be entered in the "R" field on the Tool Length Compensation page (unit: mm).

Besides the tool-tip radius, the direction of fictitious tool-tips must be acquired (refer to the position of P in Fig. 3-54). The direction is defined by integers 0~9 (Fig. 3-44). In the system with tools on the top (rear) holder, the direction 3 is for outer diameter cutting, while the direction 2 is for inner diameter cutting. The data of fictitious tool-tip direction are to be entered in the "T" field on the Tool Length page.

Once these two data are acquired, the control unit compensates for the tool-tip properly by calculating "R" and "T" values internally after giving the tool-tip radius compensation command.

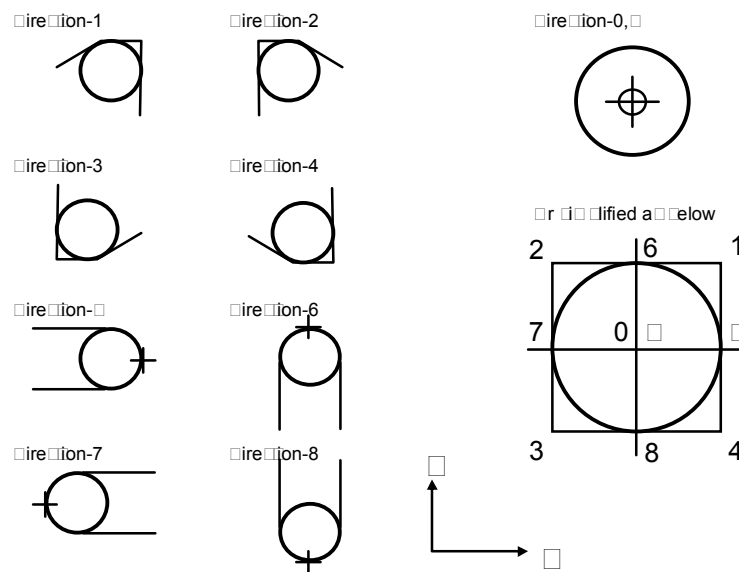

Fig 3-54 Fictitious Tool-tip Direction

Tool-tip point and tool radius compensation operation

(1) Process using center of tool-tip radius as the starting point:

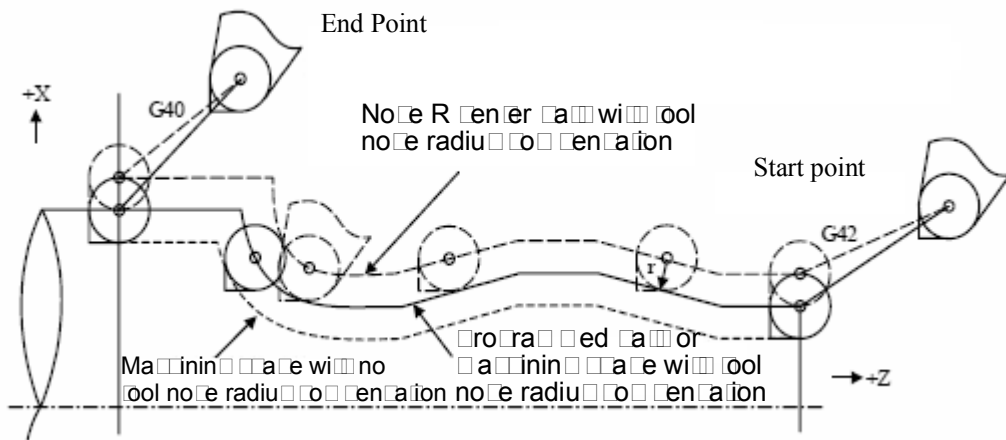

Fig 3-55

(2) Process using tool-tip as the starting point:

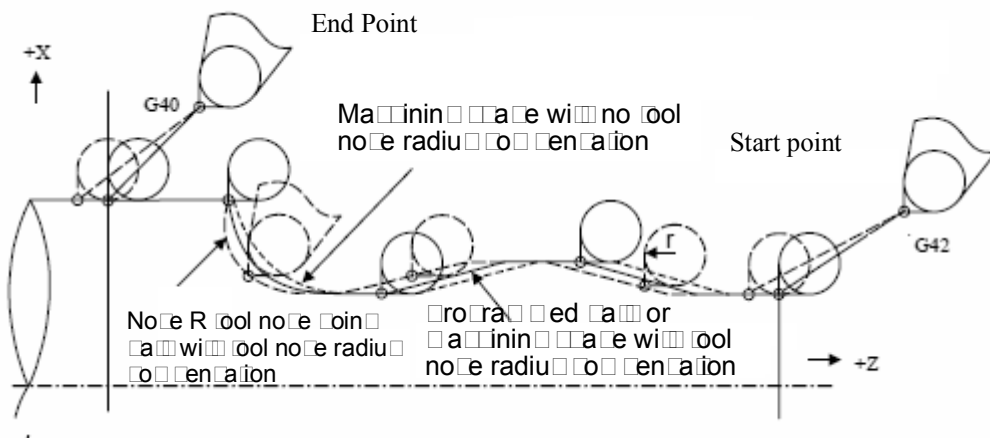

Fig 3-56

Start of tool-tip radius compensation:

When compensation is disabled and all the following conditions are met, tool-tip radius compensation starts:

1. Executing a G41.G42 command.
2. Executing a move command excluding the arc command. When used during a G02, G03 arc-cutting, system will issue an error alarm.

In a continuous or single block execution, when a compensation starts, 2 to 6 program-sections must be read for calculating an intersection point (read 2 program-sections when a move command exists; read up to 6 program-sections when a move command does not exist).

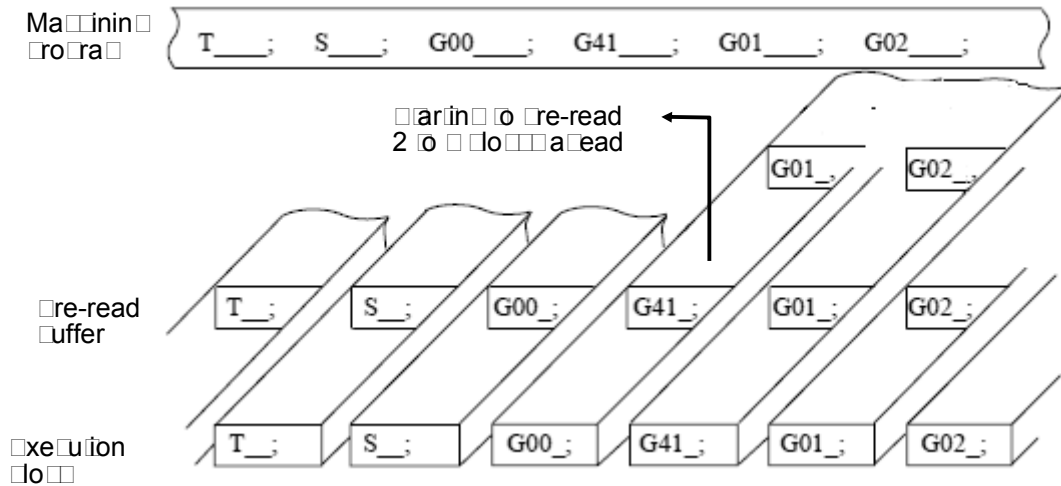

Fig 3-57

Two types of tool-tip compensation can be determined by C251: C251= 1 for Type A, C251=0 for Type B.

Note The often seen terms, Inside and Outside, are defined as follows:

Inside Two adjacent program-sections having an intersecting angle larger than or equal to 180°

Outside Two movement program-sections having an intersecting angle within $0 \sim 180^\circ$.

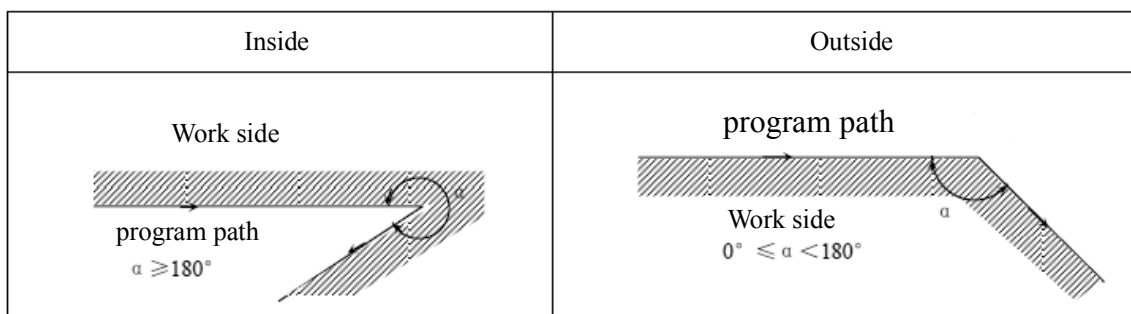

Fig 3-58

Start of tool-tip radius compensation:

With the G41.G42 command alone, the tool will not perform a movement according to tool-tip radius compensation. A tool-tip radius compensation does not start on G00; it only starts on a G01, G02, or G03 command.

When a G41.G42 command exists in the same block with a move command, the move command is processed as a G01 command.

1. In the case of a single command of Chamfer inside G41.G42: (Fig. 3-59)

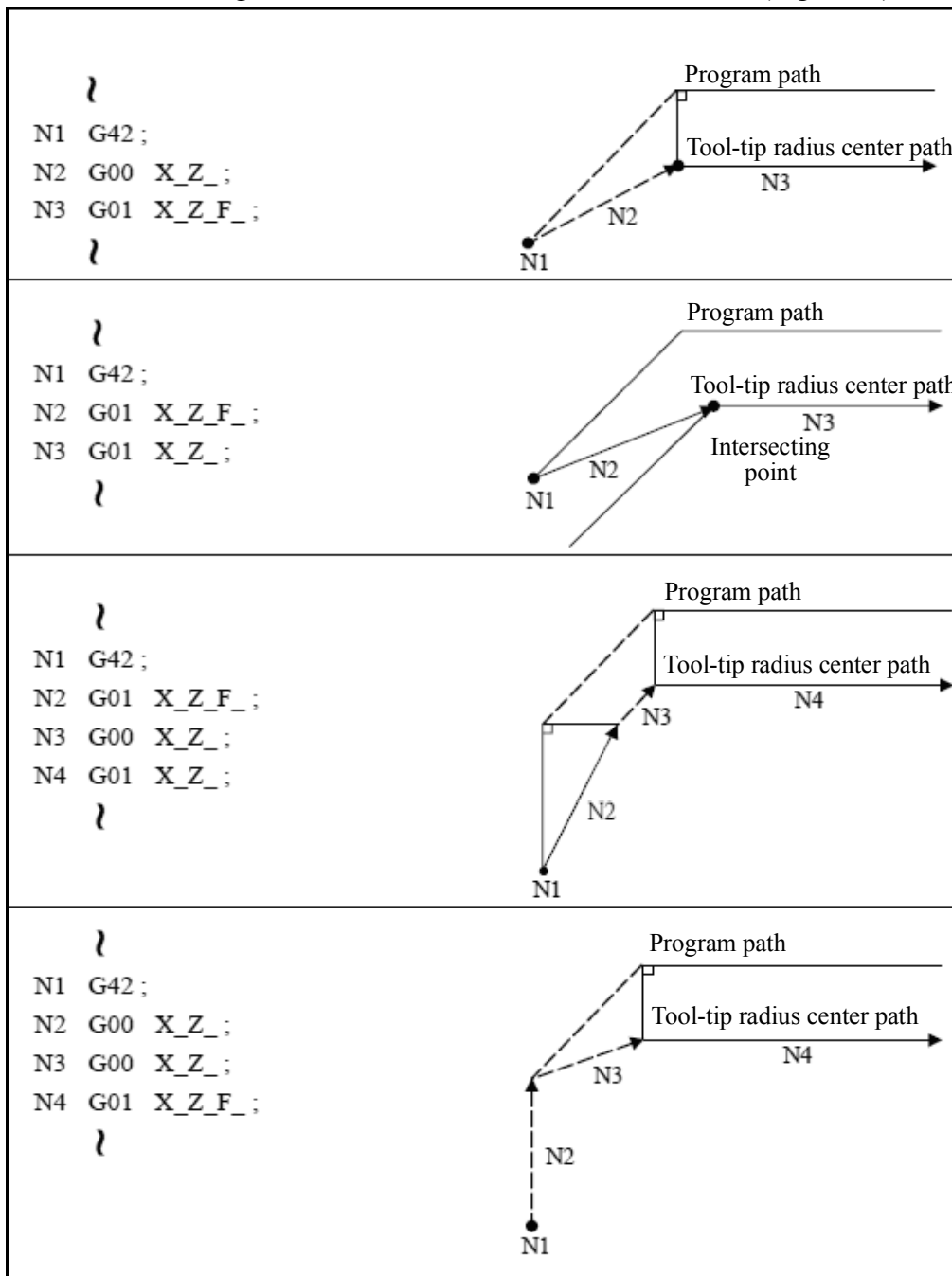

~
 N1 G42
 N2 G00 X_ Z_
 N3 G03 I_ K_ F_
 ~

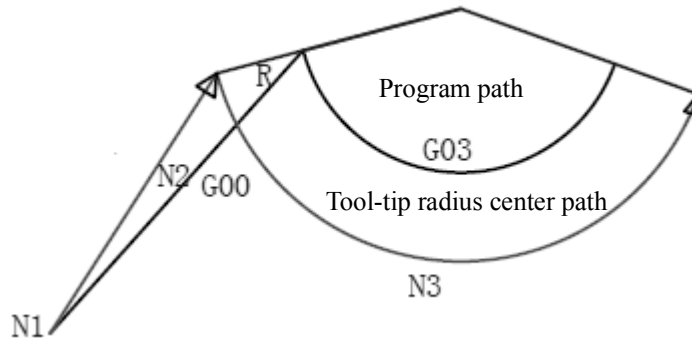

Fig 3-60

~
 N1 G42
 N2 G01 X_ Z_
 N3 G03 I_ K_ F_
 ~

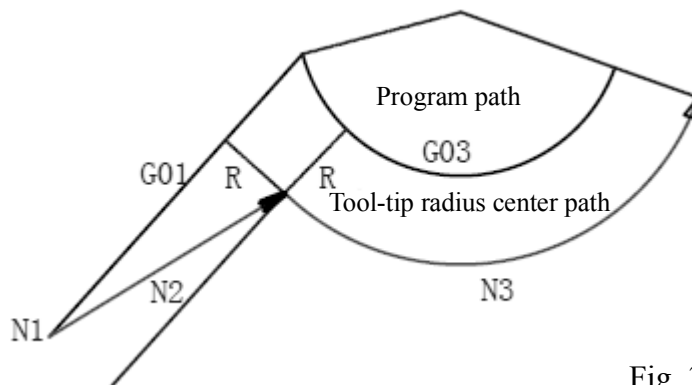

Fig 3-61

2. When chamfer inside G41.G42 exists in the same block with a move command:

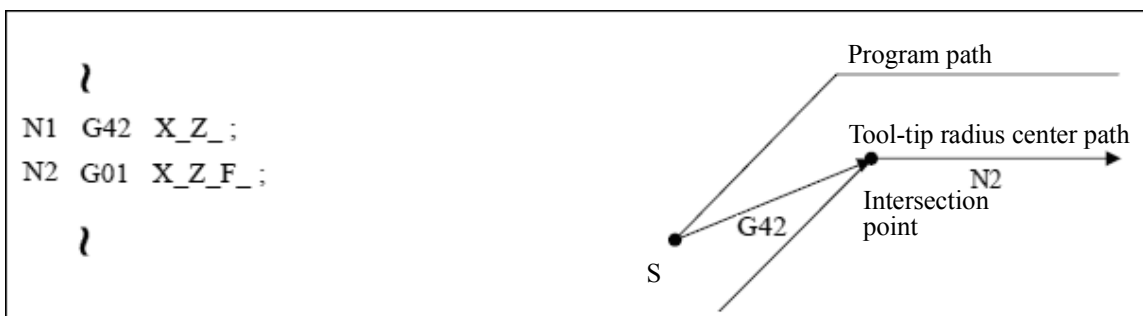

Fig 3-62

3. Chamfer outside (obtuse angle) G41.G42 command only:

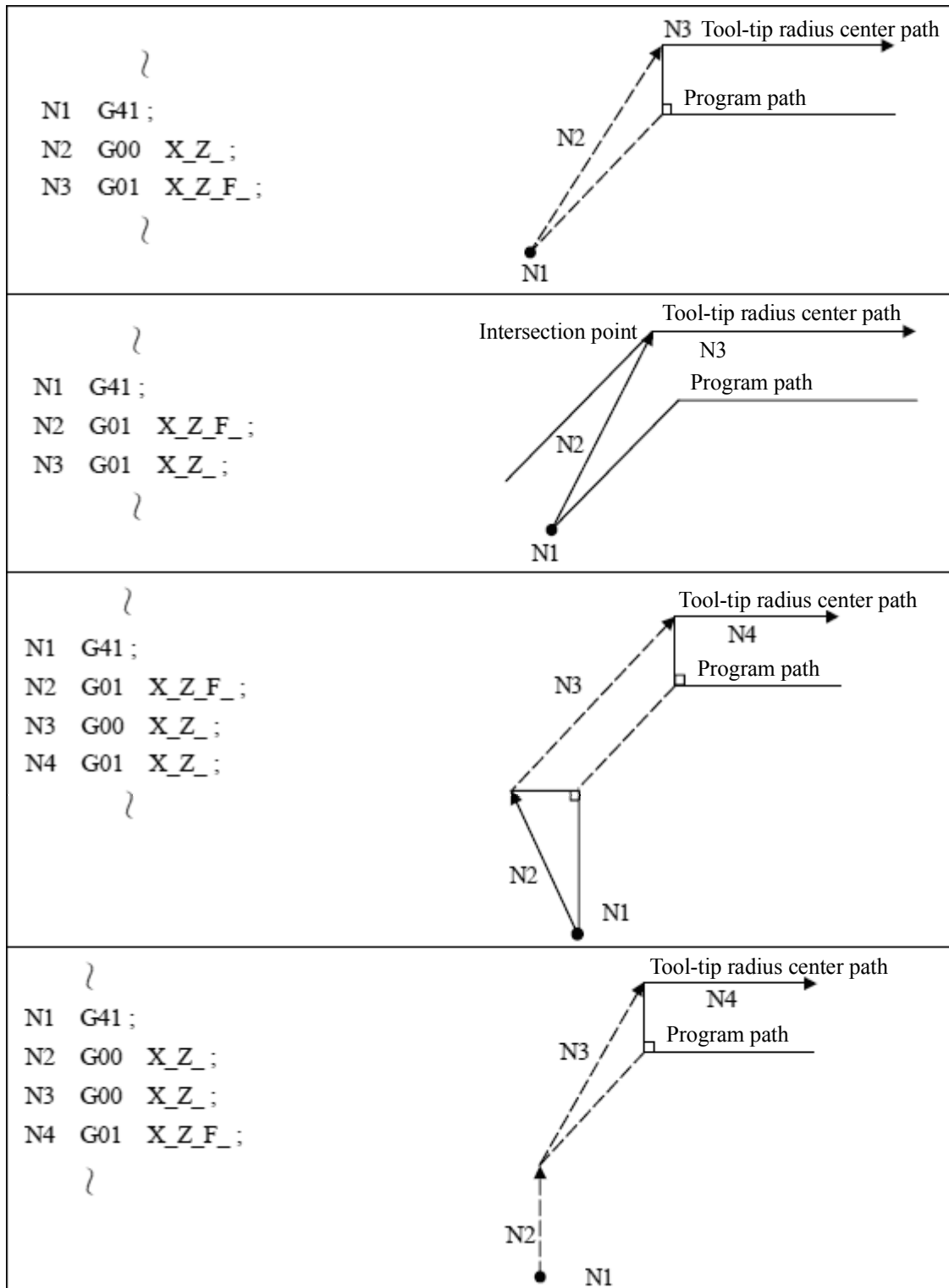

Fig 3-63

4. Chamfer outside (obtuse angle) G41.G42 exists in the same block with a move command:

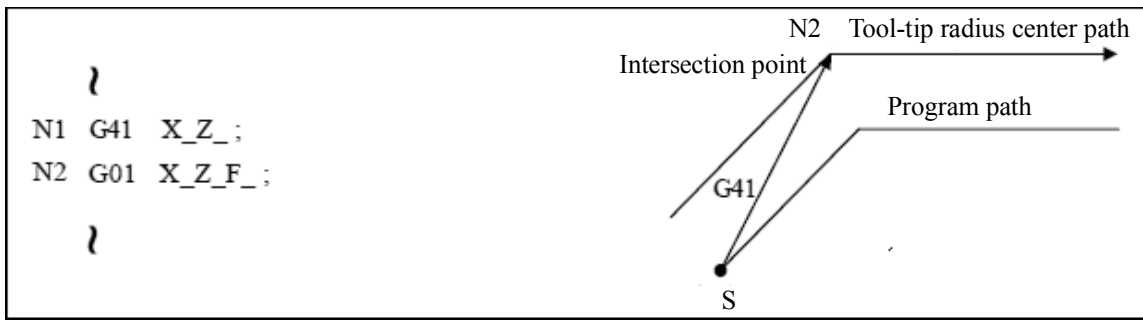

Fig 3-64

5. Chamfer outside (acute angle) G41.G42 command only:

| | Type A | Type B |
|---|--------|--------|
| <pre> } N1 G41 ; N2 G00 X_Z_ ; N3 G01 X_Z_F_ ; } </pre> | | |
| <pre> } N1 G41 ; N2 G01 X_Z_F_ ; N3 G01 X_Z_ ; } </pre> | | |
| <pre> } N1 G41 ; N2 G01 X_Z_F_ ; N3 G00 X_Z_ ; N4 G01 X_Z_ ; } </pre> | | |
| <pre> } N1 G41 ; N2 G00 X_Z_ ; N3 G00 X_Z_ ; N4 G01 X_Z_F_ ; } </pre> | | |

Fig 3-65

6. Chamfer outside (acute angle) G41.G42 exists in the same block with a move command:

| | Type A | Type B |
|--|--------|--------|
| <pre> } N1 G41 X_Z_ ; N2 G01 X_Z_F_ ; } </pre> | | |

Fig 3-66

Operation in a tool-tip radius compensation mode

In the tool-tip radius compensation (G41,G42) mode, a tool-tip radius compensation command having the same content is not valid. Pre-reading is prohibited if a G65 L50 command is included in the tool-tip radius compensation.

1. Rotation of chamfer inside:

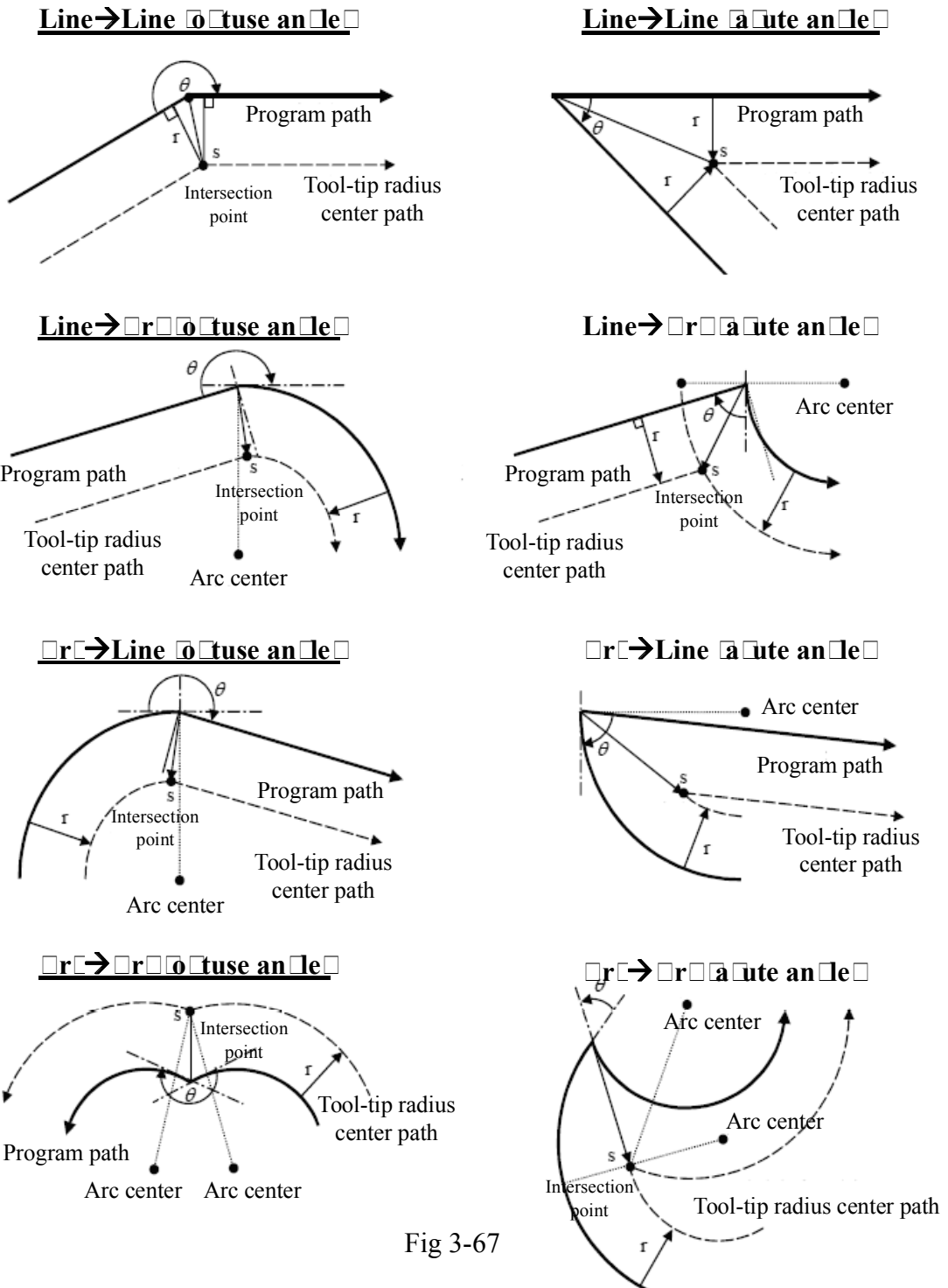
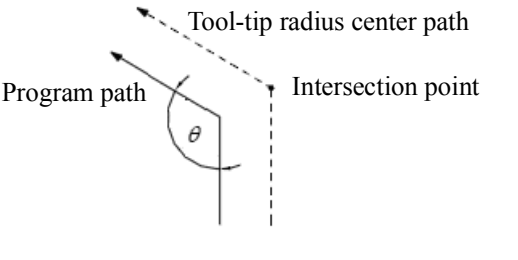
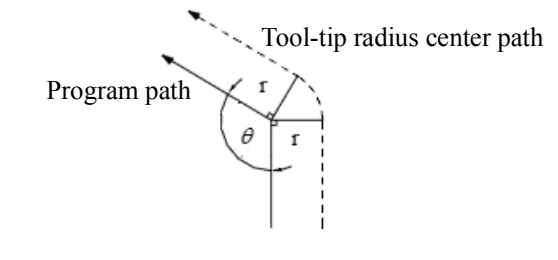
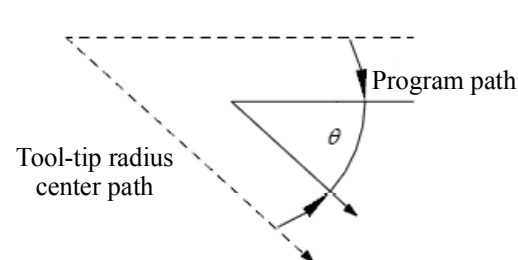
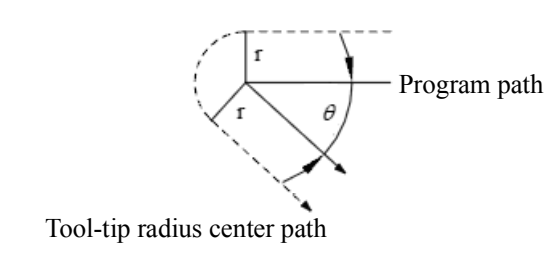
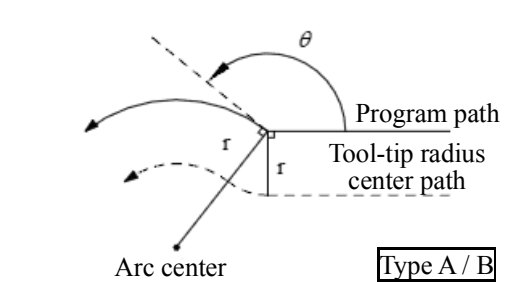
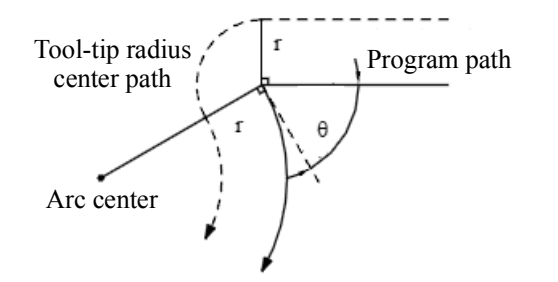
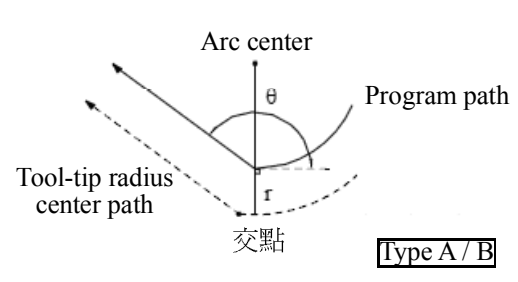
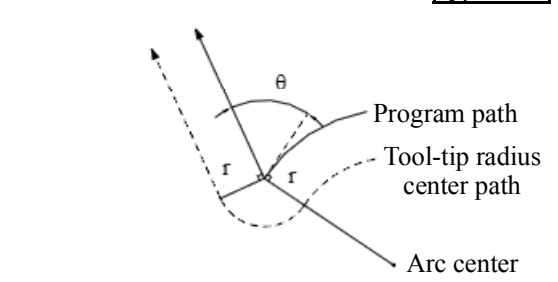
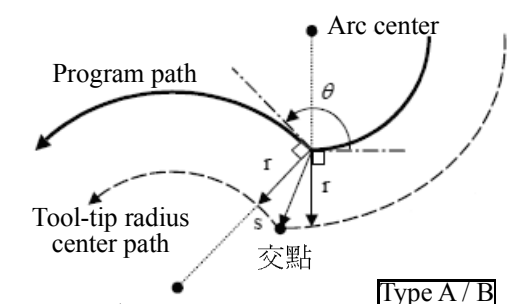
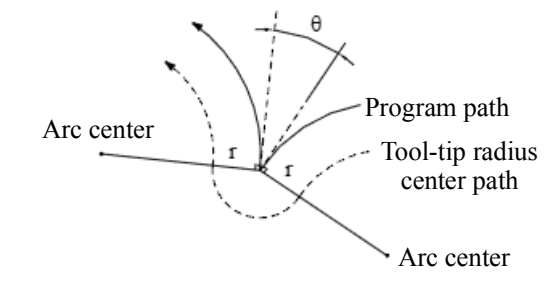

Fig 3-67

2. Rotation of Chamfer outside: (Fig. 3.68)

| | |
|--|--|
| <p>Line→Line ($90^\circ \leq \theta < 180^\circ$) Type A</p>  <p>Tool-tip radius center path Program path Intersection point θ</p> | <p>Line→Line ($90^\circ \leq \theta < 180^\circ$) Type B</p>  <p>Tool-tip radius center path Program path r θ r</p> |
| <p>Line→Line ($0^\circ < \theta < 90^\circ$) Type A</p>  <p>Program path Tool-tip radius center path θ</p> | <p>Line→Line ($0^\circ < \theta < 90^\circ$) Type B</p>  <p>Program path Tool-tip radius center path r θ r</p> |
| <p>Line→Arc ($90^\circ \leq \theta < 180^\circ$) Type A / B</p>  <p>Program path Tool-tip radius center path Arc center r θ r</p> | <p>Line→Arc ($0^\circ < \theta < 90^\circ$) Type A / B</p>  <p>Tool-tip radius center path Program path Arc center r θ r</p> |
| <p>Arc→Line ($90^\circ \leq \theta < 180^\circ$) Type A / B</p>  <p>Arc center Program path Tool-tip radius center path 交點 θ r</p> | <p>Arc→Line ($0^\circ < \theta < 90^\circ$) Type A / B</p>  <p>Program path Tool-tip radius center path Arc center θ r r</p> |
| <p>Arc→Arc ($90^\circ \leq \theta < 180^\circ$) Type A / B</p>  <p>Program path Tool-tip radius center path Arc center 交點 θ r r s</p> | <p>Arc→Arc ($0^\circ < \theta < 90^\circ$) Type A / B</p>  <p>Program path Tool-tip radius center path Arc center θ r r</p> |

Direction Change of tool-tip compensation

Direction of compensation is determined by tool-tip radius compensation command (G41, G42).

During compensation mode, without a cancellation command of the compensation, a change of the compensation command may change the direction of compensation. But the change does not change the starting section of the compensation, nor of the subsequent section of the program.

Line→Line

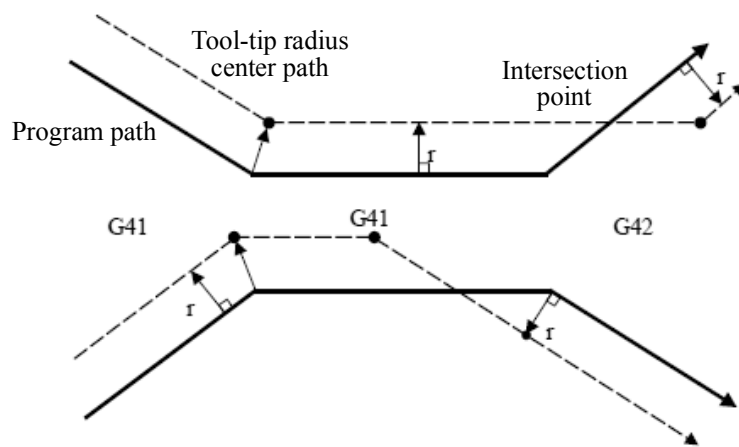

Line→r

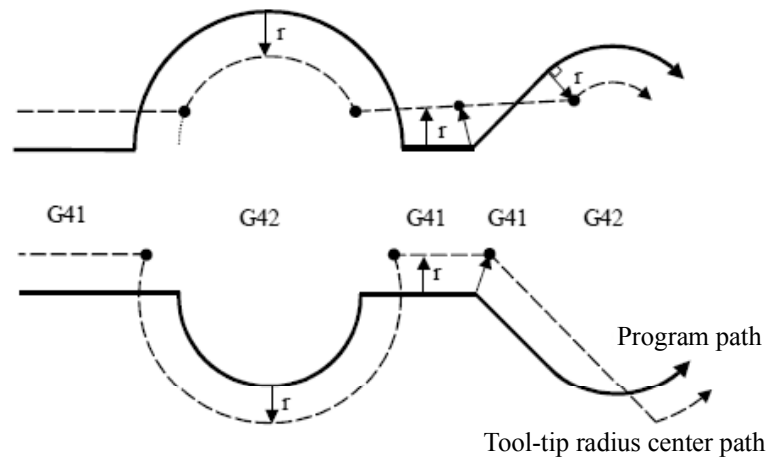

Fig 3-69 Change of compensating direction in a tool-tip radius compensation

Disabling a tool-tip radius compensation:

When tool-tip radius compensation is enabled and all the following conditions are met, the tool-tip radius compensation can be disabled:

1. A G40 command is executed.
2. Executing a move command excluding the arc command.

After reading-in the disable command of compensation, the program switches into (compensation) disabled mode which comprises the following 3 conditions:

1. A tool-tip radius compensation ends, G40 alone disables tool compensation, and a G00 precedes G40, tool compensation is disabled in the block of a G00 move command.
2. A tool-tip radius compensation ends, G40 alone disables tool compensation, and a G01/G02/G03 precedes G40, tool stops at the center of tool-tip radius vertically, tool compensation remains enabled until the first move command after G40. If no move command follows G40, tool compensation remains enabled on the encounter of an end command M02/M30; the compensation is disabled when the program is re-started, without an operation for disabling tool compensation.
3. A tool-tip radius compensation ends, if G40 command is in the same command line with a move command, tool compensation is disabled in the G40 command block.

Disabling tool radius compensation:

1. Chamfer inside G40 command only:

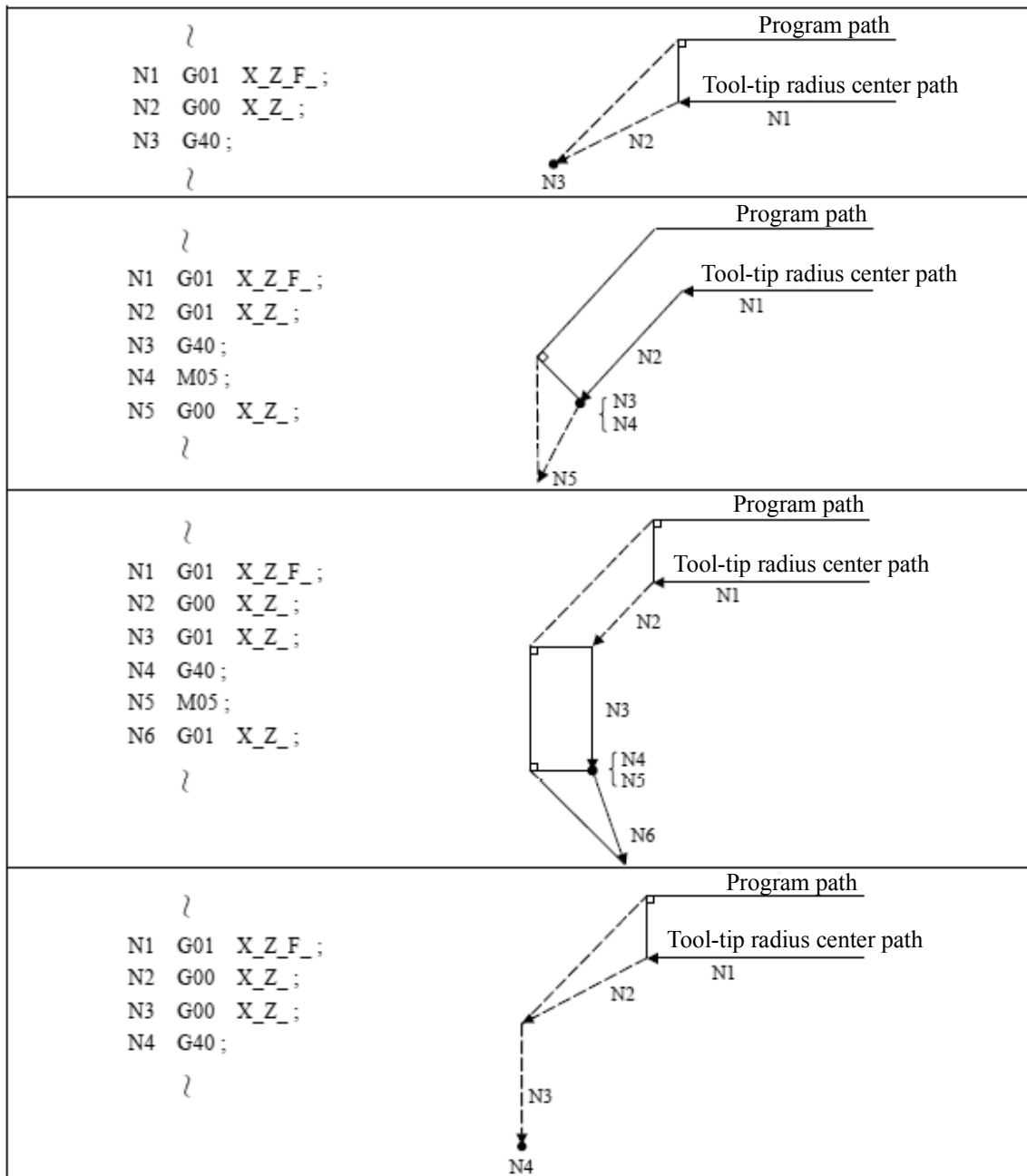

Fig 3-70

2. Chamfer inside G40 is in the same block as a move command:

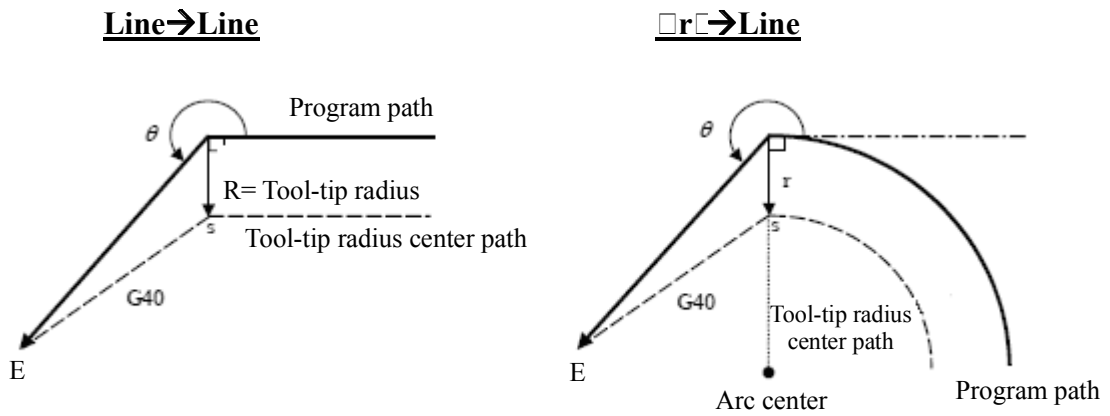

Fig 3-71

3. Chamfer outside (obtuse angle) G40 command only:

| | Type A | Type B |
|--|--------|--------|
| <pre> } N1 G01 X_Z_F_; N2 G00 X_Z_; N3 G40; } </pre> | | |
| <pre> } N1 G01 X_Z_F_; N2 G01 X_Z_; N3 G40; N4 M05; N5 G00 X_Z_; } </pre> | | |
| <pre> } N1 G01 X_Z_F_; N2 G00 X_Z_; N3 G01 X_Z_; N4 G40; N5 M05; N6 G01 X_Z_; } </pre> | | |
| <pre> } N1 G01 X_Z_F_; N2 G00 X_Z_; N3 G00 X_Z_; N4 G40; } </pre> | | |

Fig 3-72

4. Chamfer outside (obtuse angle) G40 and move command in the same block:

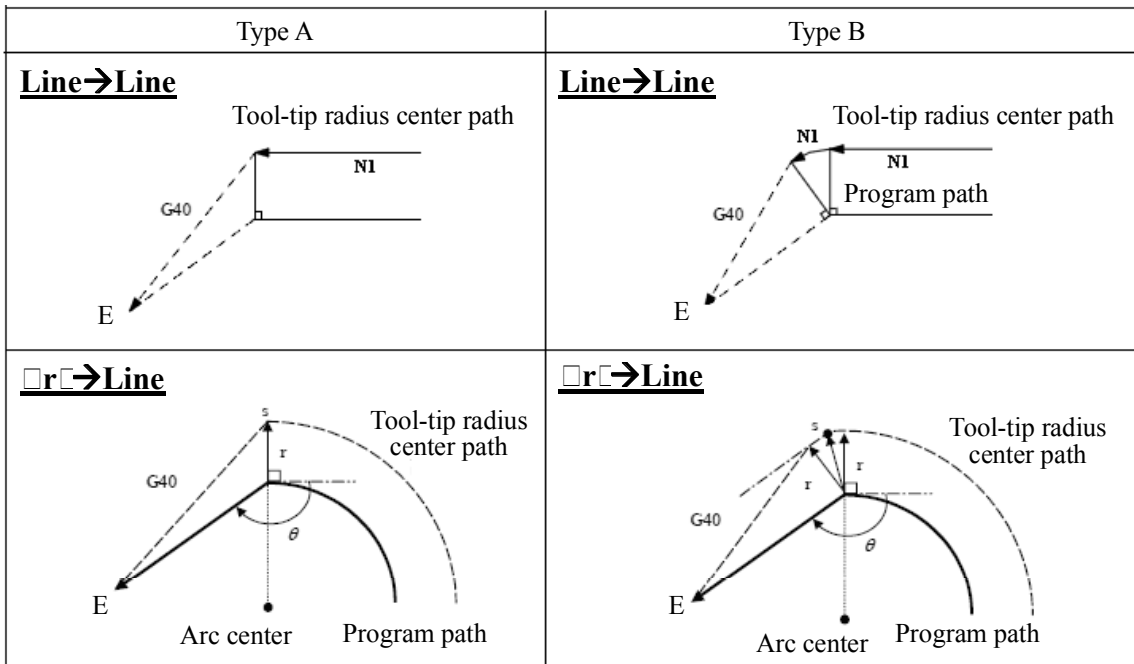

Fig 3-73

5. Chamfer outside (acute angle) G40 command only:

| | Type A | Type B |
|--|--------|--------|
| <pre> } N1 G01 X_Z_F_; N2 G00 X_Z_; N3 G40; } </pre> | | |
| <pre> } N1 G01 X_Z_F_; N2 G01 X_Z_; N3 G40; N4 M05; N5 G00 X_Z_; } </pre> | | |
| <pre> } N1 G01 X_Z_F_; N2 G00 X_Z_; N3 G01 X_Z_; N4 G40; N5 M05; N6 G01 X_Z_; } </pre> | | |
| <pre> } N1 G01 X_Z_F_; N2 G00 X_Z_; N3 G00 X_Z_; N4 G40; } </pre> | | |

Fig 3-74

6. Chamfer outside (acute angle) G40 and move command in the same block:

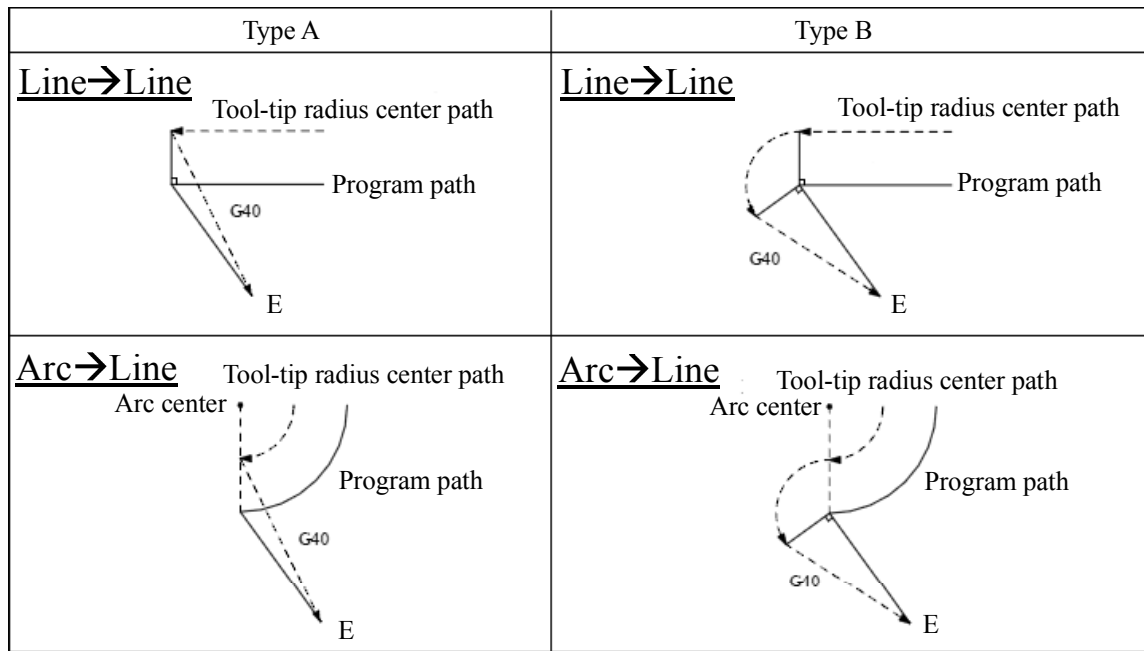

Fig 3-75

2 Interference Check

Functions and Purposes

When pre-reading-in 2 program blocks to perform a tool-tip radius compensation, it often results in cutting into the workpiece; this is called an interference.

When cutting a stepwise work-piece with a step value smaller than the tool radius, an over-cutting alarm is generated as shown in Figure 3-51.

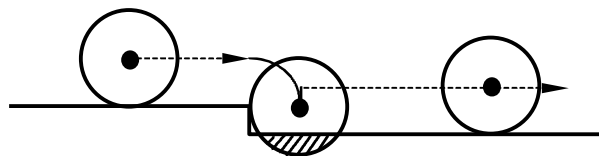

Fig. 3-76 Over-cutting (Shaded Area)

An interference check is a check against such conditions, for taking responding actions according to the parameter.

Interference handling comprises the following 3 functions that can be selected by parameter setting.

| Function | Parameter | Action |
|---------------------------------|----------------|--|
| Interference check alarm | Parameter 20=0 | Issues alarm and stop machine before entering block of interference. |
| Interference avoidance function | Parameter 20=1 | Alter the path automatically to avoid interference. |
| Interference check disable | Parameter 20=2 | Cutting action continues, allowing cutting into workpiece. |

Details □□□□

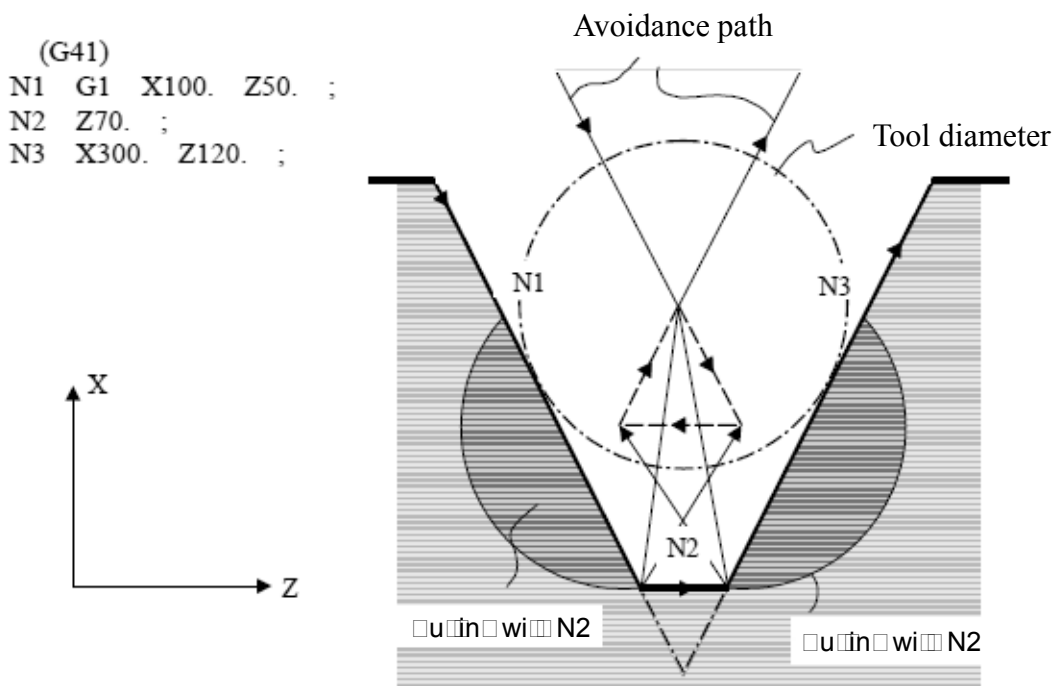

Fig 3-77

1. Interference check alarm: An alarm occurs before executing N1, process stops.
2. Interference avoidance function: N1 and N3 calculate intersection point, for altering the path to avoid interference.
3. Interference check disabled: continue cutting into N1 and N3 lines.

Interference handling alarm

An interference alarm occurs when any of the following conditions take place:

1. Interference check alarm selected: In the event of interference, an alarm is issued before the block of interference in the program.
2. Interference avoidance function selected:
 - A. Interference occurs in two consecutive blocks in the program. (Interference in both N2 and N3).

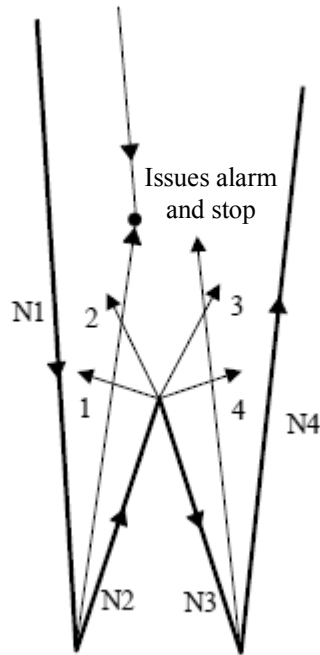

Fig 3-78

- B. An avoidance path cannot be found (no intersection of N2 and N4),

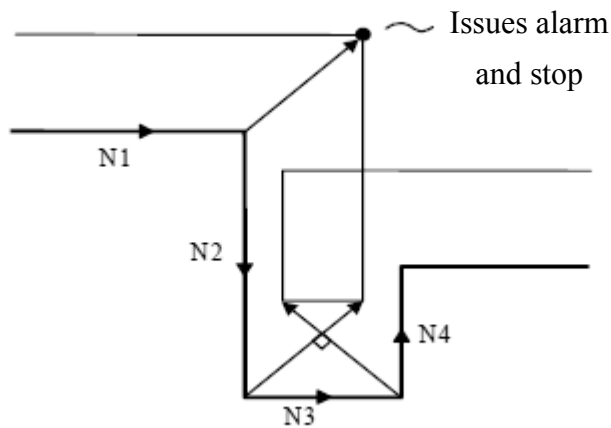

Fig 3-79

- C. Direction of program path is opposite the path after interference avoidance (direction of path after interference avoidance is opposite to N2 direction).

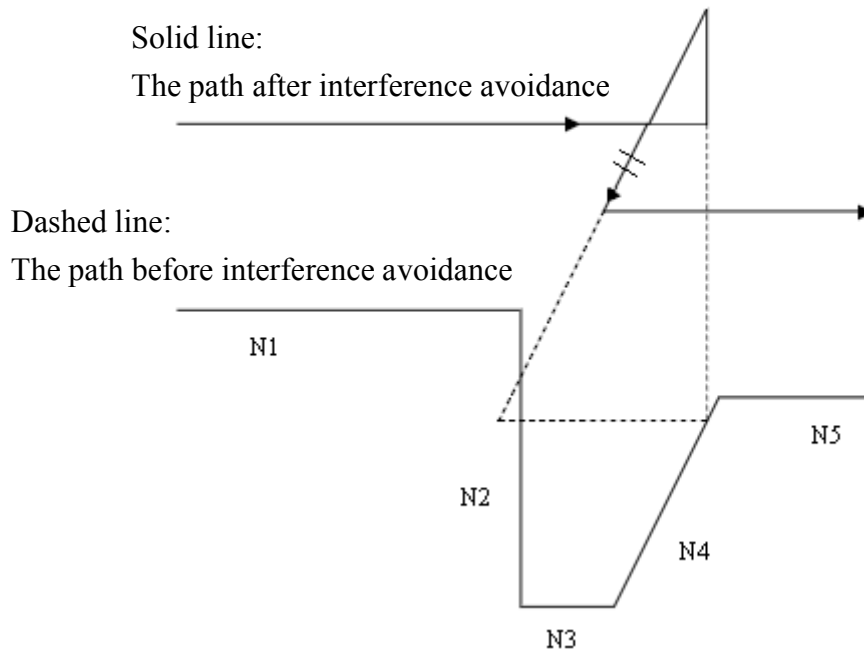

Fig 3-80

2. Notes on Tool Radius Compensation

1. When radius compensation is executed, there should be at least one block containing positioning commands between two neighboring blocks. The following commands do not perform tool positioning, though they have mechanical actions. Therefore they are not allowed for continuous blocks .

M05 · · · · M-code output

S2100 · · · · S-code output

G4 X1.000 · · · · Suspension

G1 U0.000 · · · · Feed distance=0

G98 · · · · G-code only

2. Only G00 and G01 are applicable to blocks with tool-tip radius compensation. Arc commands G02, G03 are not allowed
3. The move block before a tool-tip radius compensation command must be G00 or G01. Arc commands G02, G03 are not allowed.
4. The tool radius compensation function is not available for MDI operation.
5. Tool-tip radius compensation is not allowed for G74, G75, or G76.

- 6. Pre-read preventive commands (G65, L50) are not allowed during the tool-tip radius compensation mode.

Tool-tip radius Compensation example

Tool number = 02, tool-tip direction = 3, tool-tip radius = 1.5 mm. The X-axis coordinate is defined by the diameter.

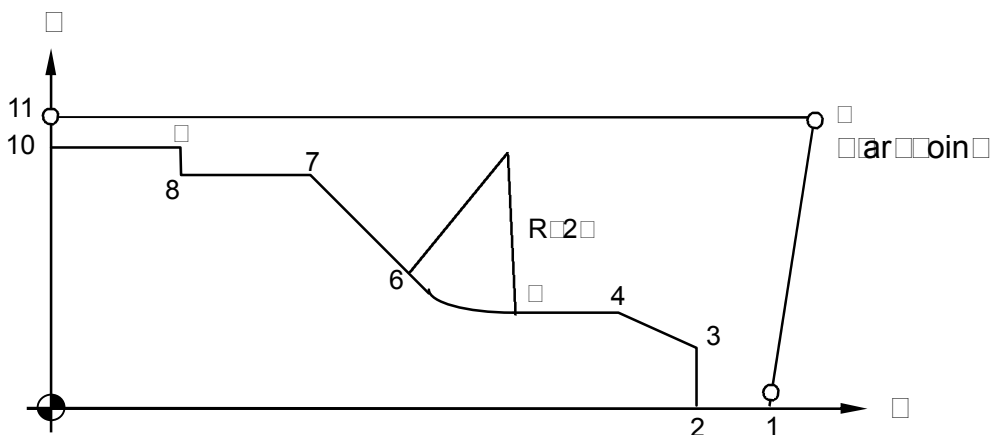

Fig. 3-81

| | |
|-----------------------------------|--|
| N10 G0 X100. Z120. | • • • Point S |
| N20 G0 X0. Z110. | • • • Point 1 |
| N30 M3 S2000 | |
| N40 G42 Z100. T02 F3.0 | • • • Point 2, compensation insertion |
| N50 G1 X20. | • • • Point 3 |
| N60 X30. Z91.34 | • • • Point 4 |
| N70 Z75. | • • • Point 5 |
| N80 G02 X44.644 Z57.322 I25. F1.5 | • • • Point 6, arc cutting |
| N90 G01 X76. Z37.644 F3.0 | • • • Point 7 |
| N100 Z20. | • • • Point 8 |
| N110 X80. | • • • Point 9 |
| N120 Z0. | • • • Point 10 |
| N130 G40 X90. | • • • Point 11, compensation cancellation |
| N140 G0 X100. Z120. | • • • Point S |
| N150 M05 | |

Example of the Program:

G54: Designate the Working Coordinate System as G54.
 G52 X19.0 Z30.0: Designate Local Coordinate System to X15.0 Z30.0 position of the current working coordinate system.
 G00 X10. Z10.: Quickly move to X10.0 Z10.0 position of Local Coordinate System.
 G52 X0.0 Z0.0: Cancel the Local Coordinate System setting.

Remark:

1. The Resume Signal will override the Local Coordinate System.
2. When switching G54_ _G59 Working Coordinate System, the Local Coordinate System will be cancelled.

2 2 asi a hine oordinate s ste

Co and For at

G53 X__ Y__ Z__ A__ B__ C__ P0
 or G53 X__ Y__ Z__ A__ B__ C__

X:X-axis moves to the designated Machine Coordinate X position with G00 speed.
 Y:Y-axis moves to the designated Machine Coordinate Y position with G00 speed.
 Z:Z-axis moves to the designated Machine Coordinate Z position with G00 speed.
 A:A-axis moves to the designated Machine Coordinate A position with G00 speed.
 B:B-axis moves to the designated Machine Coordinate B position with G00 speed.
 C:C-axis moves to the designated Machine Coordinate C position with G00 speed.

G53 X__ Y__ Z__ A__ B__ C__ P1

X:X-axis moves to the designated Machine Coordinate X position with G01 speed of previous node.
 Y:Y-axis moves to the designated Machine Coordinate Y position with G01 speed of previous node.
 Z:Z-axis moves to the designated Machine Coordinate Z position with G01 speed of previous node.

A:A-axis moves to the designated Machine Coordinate A position with G01 speed of previous node.

B:B-axis moves to the designated Machine Coordinate B position with G01 speed of previous node.

C:C-axis moves to the designated Machine Coordinate C position with G01 speed of previous node.

Description

The Home Position of the machine is the fixed home position being set by the manufacturer when manufacturing the CNC machine and such Coordinate System belongs to a fixed system. When designated by G53 Command and coordinate command, the Tool will move to the position designated for the basic coordinate system of the machine. Soon as the Tool returns to zero point (0, 0, 0) of the machine, it means the Home Position of the machine's coordinate system.

Notice

1. G53 Command will be valid for the designate node.
2. Before giving the G53 Command, the Tool offsetting must be cancelled (length, wearing, tip radius offsetting).
3. The command shall be valid under absolute value programming status, and will not avail under incremental value programming.

G53 or **Coordinate System**

Purpose and functions

Six sets of different work origins can be set. The coordinate system comprising these work origins is named Work Coordinate System. The major merit of a Work Coordinate System is the simplified calculation of coordinates in the process program.

Details

The program use these work coordinate origins via commands G54-G59. According to process requirements and program design, the user may select any set, or 2 sets or even 6 sets for the process. The major merit of these Work Coordinate Systems is the

simplified calculation of coordinates in the process program.

1. The following table describes the relationship between G54~G59 Work Coordinate System and setting values of X, Y, Z, A, B, C items of MCM parameters 1~120. These coordinate parameters (work origins) correspond to machine coordinates by setting the machine origin as zero. therefore the work origin settings of work coordinates G54~G59 are as follows
An illustration is given taking X & Z 2 axes as the example:

Table 3-12

| Work coordinate system | Parameter Item/Number | X-axis setting value | Z-axis setting value |
|------------------------|-----------------------|----------------------|----------------------|
| G54 | 1(X), 3(Z) | -100.000 | -70.000 |
| G55 | 21(X), 23(Z) | -30.000 | -80.000 |
| G56 | 41(X), 43(Z) | -50.000 | -80.000 |
| G57 | 61(X), 63(Z) | -50.000 | -70.000 |
| G58 | 81(X), 83(Z) | -60.000 | -40.000 |
| G59 | 101(X), 103(Z) | -40.000 | -20.000 |

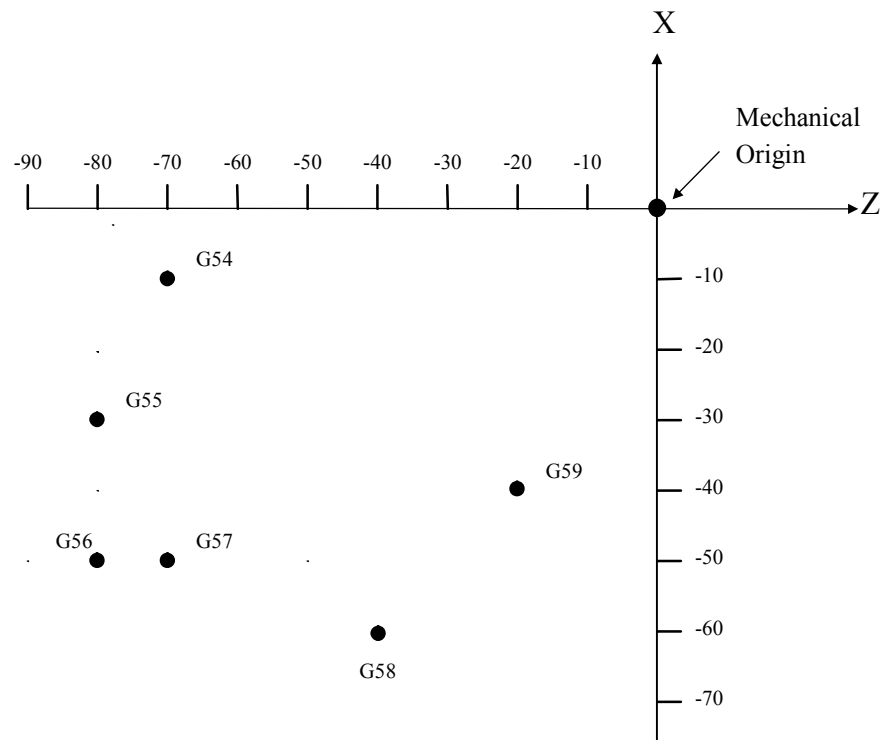

Fig. 3-83 G54~G59 Work Coordinate System

2. When a Work Coordinate System is selected, program coordinates also change accordingly. The altered coordinates are based on the Work Coordinate System. Adding circular and semi-circular cuttings in program of the above figure, the application of G54 and G55 can be described by the following example. (Fig.3-84)

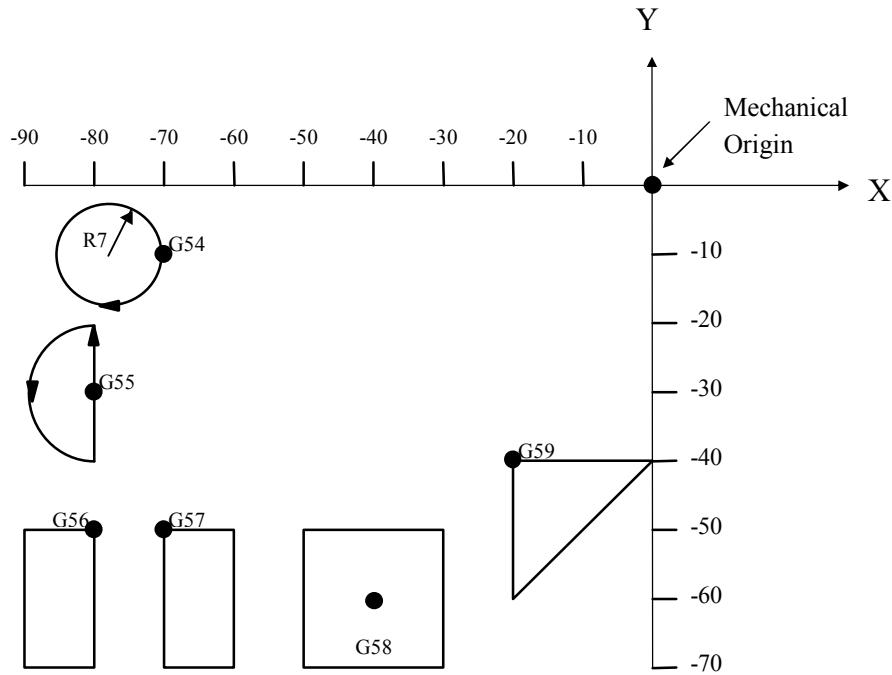

Fig. 3-84 G54~G59 application

□ro□ra□ □□a□ple□

| | |
|-------------------------|---|
| N1 G54 | ... Select the first work coordinate |
| N2 G0 X0 Z0 | ... Positioned to program coordinates X0, Z0, (Machine coordinates X-10. Z-70.) |
| N3 G2 I-7.0 F200 | ... Cut a full circle with R7.0 clockwise |
| N4 G0 | ... Set feed mode as FAST |
| N5 G55 | ... Select the second work coordinate |
| N2 G0 X0 Y0 | ... Positioned to program coordinates X0, Z0, (Machine coordinates X-30., Z-80.) |
| N6 G1 W10.0 F300 | ... Z-axis cutting incremental feed command, travel +10.0 |
| N7 G3 W-20.0 R10.0 F300 | ... Cut a R10.0 semi-circle counterclockwise |
| N8 G1 W10.0 F300. | ... Z- axis cutting incremental feed command, |

travel +10.0

N9 G28 ... If MCM parameter of first reference point =0,
program returns to machine origin

N10 M2 ... Program end

1. Selection of Work Coordinate System is done by giving G54~G59 commands.
2. After giving G54~G59 commands, machine coordinates of the program origin alter according to the new Work Coordinate System.
3. Controller automatically set as G54 Work Coordinate System when the machine starts or when Reset is pressed.

2. Corner chamfer and round-angle chamfer functions

In a command block for forming a corner from a continuous line of any arbitrary angle or from an arc, “C” or “R” can be used at the end of block to perform a chamfer or a round-angle chamfer. They are applicable to both absolute and incremental commands.

2.1 Chamfer and Round-angle Chamfer

Functions and Purposes

In 2 consecutive blocks, the “C” command in the first block executes a corner chamfer, “C” stands for the length from the assumed starting point to the end point of the chamfer.

Code and Format

N100 G0x X__ Z__ ,C__;
N200 G0x X__ Z__

Where:

G0x : can be any of the G00, G01, G02, and G03 commands.

,C_ : is the length from the assumed starting point to the end point of the chamfer.

Example

1. Line—Arc

Absolute value and

| |
|--------------------------------|
| N1 G28 X Z; |
| N2 G00 X50. Z100.; |
| N3 G01 X150. Z50. ,C20. F100 ; |
| N4 G02 X50. Z0 I0 K-50. ; |
| : |

Relative value and

| |
|--------------------------------|
| N1 G28 X Z; |
| N2 G00 U25. W100.; |
| N3 G01 U50. W-50. ,C20. F100 ; |
| N4 G02 U-50. W-50. I0 K-50. ; |
| : |

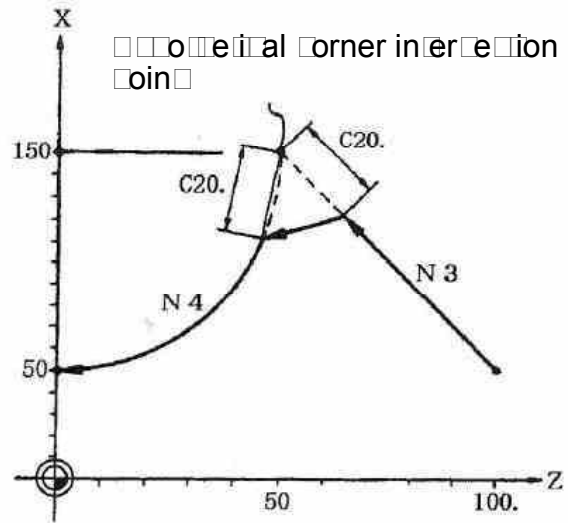

Unit (mm)

Fig. 3-85

2. Arc—Arc

Absolute value and

| |
|--|
| N1 G28 X Z; |
| N2 G00 X20. Z140. ; |
| N3 G02 X100. Z60. I100. K0. ,C20. F100 ; |
| N4 X60. Z0 I80. K-60. ; |
| : |

Relative value and

| |
|--------------------------------------|
| N1 G28 X Z; |
| N2 G00 U10. W140.; |
| N3 G02 U40. W-80. R100. ,C20. F100 ; |
| N4 U-20. W-60. I80. K-60. ; |

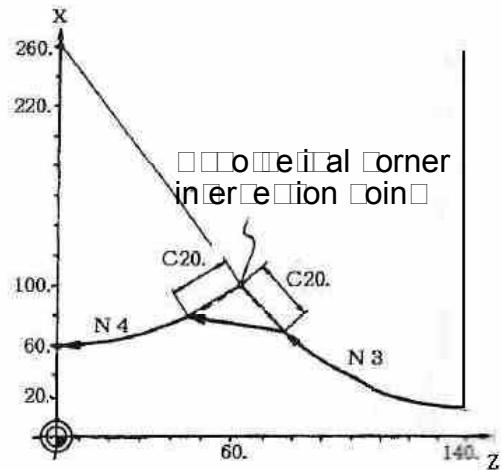

Unit (mm)

Fig. 3-86

3.2 Round-angle chamfer

Functions and Purposes

In 2 consecutive blocks, the “R” command in the first block executes a round-angle chamfer. “R” stands for the radius of arc of the round-angle chamfer.

Code and Format

```
N100 G0x X__ Z__,R__ ;
N200 G0x X__ Z__ ;
```

Where:

G0x : can be any of the G00, G01, G02, and G03 commands.

,R_ : is the radius of round-angle chamfer.

Program Example

1. Line—Arc

Absolute value mode and

| |
|--------------------------------|
| N1 G28 X Z ; |
| N2 G00 X60. Z100. ; |
| N3 G01 X160. Z50. ,R10. F100 ; |
| N4 G02 X60. Z0 I0 K-50. ; |
| ; |

Relative value mode and

| |
|--------------------------------|
| N1 G28 X Z ; |
| N2 G00 U30. W100. ; |
| N3 G01 U50. W-50. ,R10. F100 ; |
| N4 G02 U-50. W-50. I0 K-50. ; |
| ; |

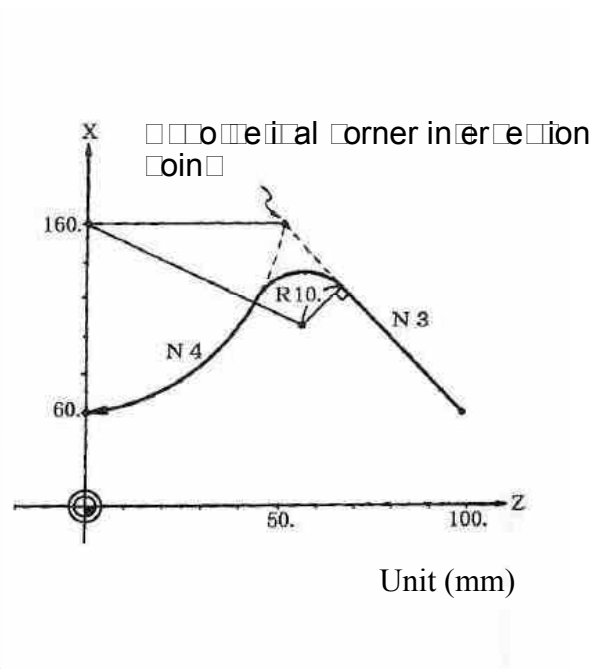

Fig. 3-87

Example

N01 G00 X50.0 Z50.0; Fast positioning to a specified point

N02 G01 Z100.0,A45.0; end point absolute Z-coordinate is 100, tool path is in a 45° phase difference with the level axis.

X-coordinate will be 100 after program execution.

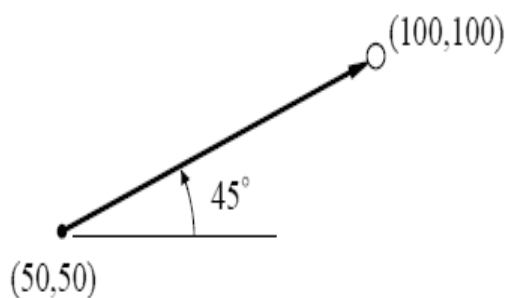

Fig. 3-90

Details

1. Angle indication:

Starting from the first axis (horizontal axis) of the selected plane, the counterclockwise direction (CCW) is positive, counterclockwise direction (CW) is negative.

2. Range of angle:

– $\leq \theta \leq 360.00$, for an angle exceeding the 360.00 range, divide the angle by 360.00 degrees and take the remainder. E.g., for an angle of 400.00 degrees, the remainder 40.00 after divided by 360.00 will be the specified angle.

Other relevant functions

Line angle + Chamfer/ Round-angle chamfer

□□1 :

N1 G01 X___,A___,C___

N2 G03 X___ Z___ I___ J___

G01 X__Z__ , A__ ; Specifies the absolute coordinate of the end of the next block and the inclination.

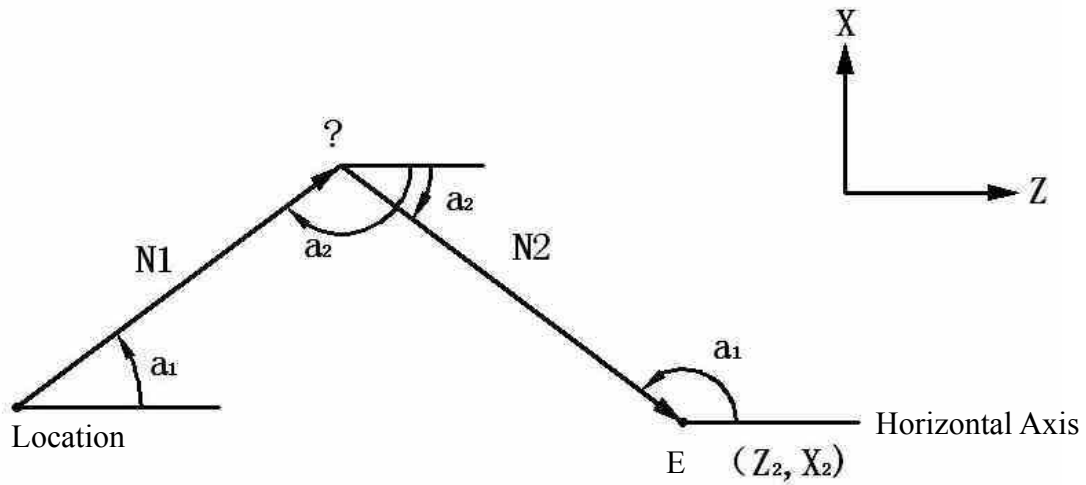

Fig. 3-93

Example

```
N01 G00 X0.0 Z0.0 ;
N02 G01,A45.0 ;
N03 Z90.0 X0.0 ,A135.0 ;
```

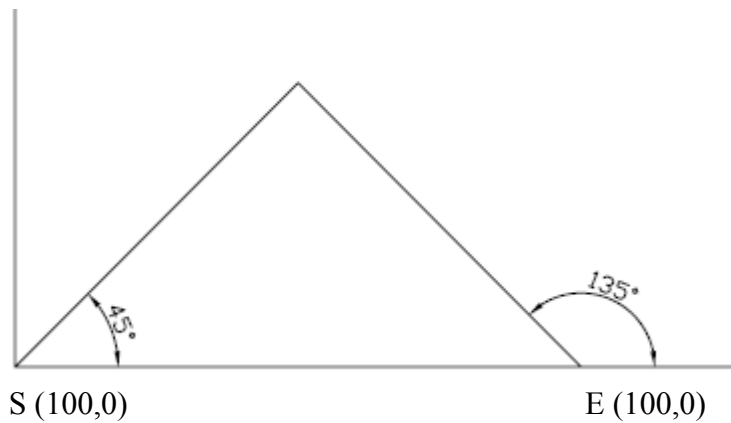

Fig. 3-94

Details

1. Angle indication: Starting from the first axis (horizontal axis) of the selected plane, the counterclockwise direction (CCW) is positive, counterclockwise direction (CW) is negative.

2. Range of angle: $-360.00 \leq \theta \leq 360.00$, for an angle exceeding the 360.00 range, divide the angle by 360.00 degrees and take the remainder. E.g., for an angle of 400.00 degrees, the remainder 40.00 after divided by 360.00 will be the specified angle.
3. Report an error if relative coordinates are used for the end coordinates of the second block.
4. Report an error if the two lines have no any intersection point, or the intersection angle is less than 1 degree.

Other relevant functions

1. Specify a chamfer or round-angle chamfer only when the angle of the first block is specified.

□□1 :

```
N1 G01 ,Aa1 , Cc1
N2 G01 Xx2 Zz2,Aa2
```

□□2 :

```
N1 G01 ,Aa1 , Rr1
N2 G01 Xx2 Zz2,Aa2
```

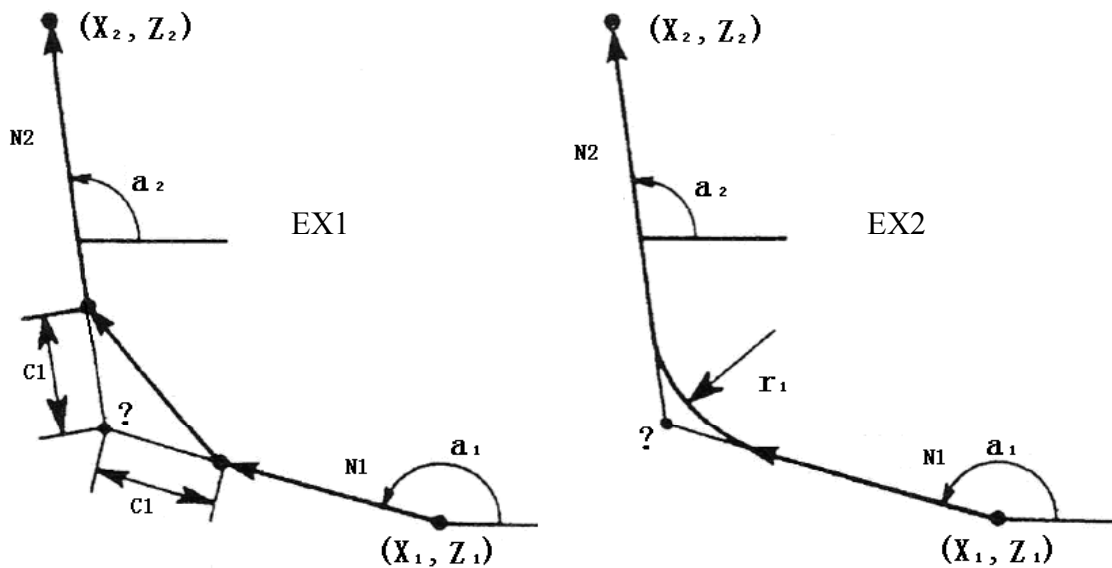

Fig. 3-95

2. Geometry function command 1 can be performed after a line angle is specified.

□□1 :

```
N1 G01 Xx2 ,Aa1
N2 G01 ,Aa2N3 G01 Xx3 Zz3 ,Aa3
```

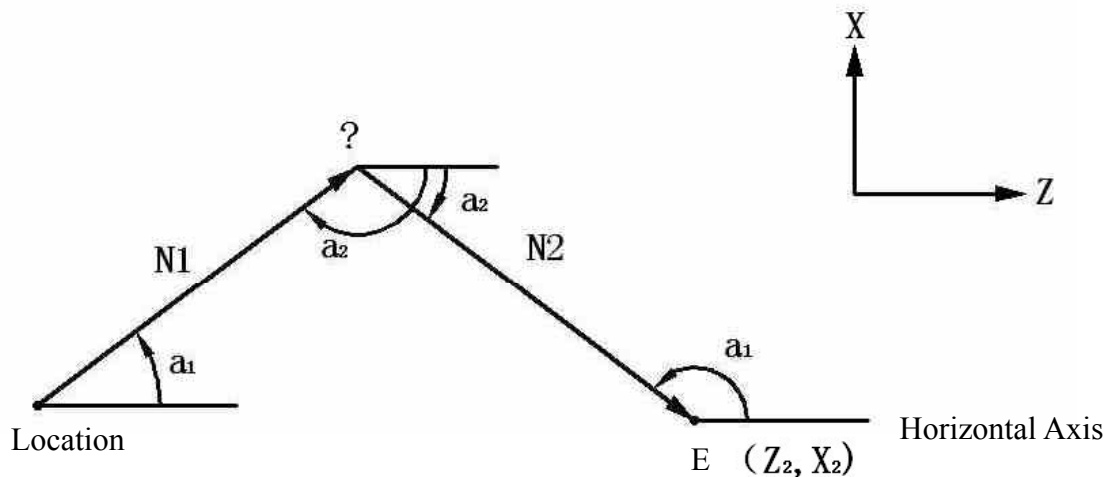

Fig. 3-96

□□2 Auto-mati-cal-culation of Line-Arc-interse-ction point

Functions and Purposes

Automatically calculate the coordinates of a line-arc intersection point when it is not specified, with automatic control of the move path,

Codes and Formats

| | |
|-------------------------------|--|
| G01,A___ | ; Specifies inclination of the first line |
| G02(G03) X___Z___P___Q___H___ | ; Specifies the end point and absolute coordinates of the center of the circle of the next block, and the selection of the intersection point. |

Note

P, Q: the absolute coordinates of centers of arcs of the X, Z-axes
H : Line-arc intersection selection

- 1 : Using the shorter line as the intersection.
- 2 : Using the longer line as the intersection. [???

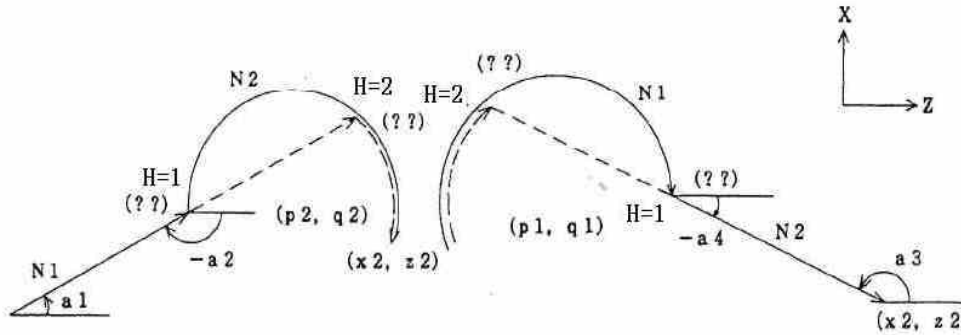

Fig. 3-97

N1 G01 ,Aa1

N1 G02(G03)Pp1 Qq1 H_

N2 G02(G03) Xx2 Zz2 Pp2 Qq2 H_

N2 G01 Xx2 Zz2 ,Aa3

Details □

1. Report an error when the second block is not absolute coordinates.
2. Report an error when the second block is an arc without P,Q specifications.
3. Report an error if the lines have no intersection point with the arc.

□relationship □ith other fun□tions□

1. Finding line-arc intersection point + chamfer

□□1 :

N1 G01,A___,C___

N2 G03 X___ Z___ P___ Q___ H___

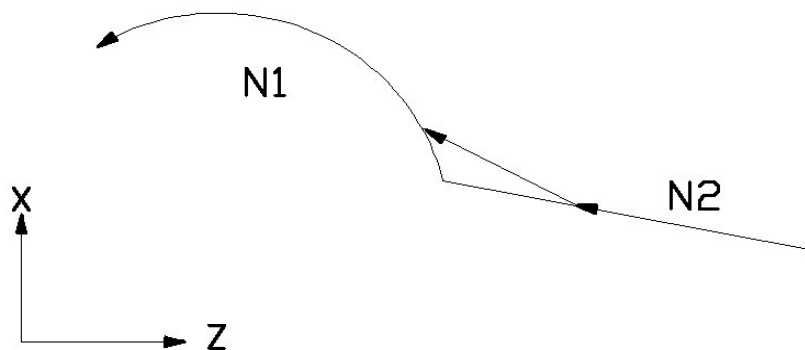

Fig. 3-98

2. Finding line-arc intersection point + round-angle chamfer

□□2 :

N1 G01,A __,R __

N2 G03 X__ Z__ P__ Q__ H__

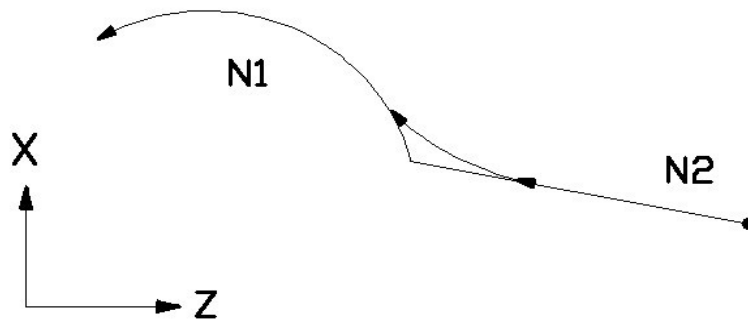



Fig. 3-99

MCM Parameters

MCM Parameters

The MCM parameter setting function allows the user to define the controller system constants according to mechanical specifications and machining conditions. These parameters are classified into two groups: basic parameters and MCM parameters.

Basic Parameters

Quickly press the  key twice to enter the parameter setting screen, as shown below:

| | | | | |
|--|--------|--------------|--|------------------|
| G71,G72 go into | X-AXIS | -00.000 inch | Z-AXIS | -00.000 inch |
| G73 amount cutting | | -00.000 inch | | -00.000 inch |
| G71,G72 retreat | | -00.000 inch | G73 segmentation | 0000 |
| G74,G75 retreat | | -00.000 inch | G76 fine cutting | 0000 |
| G76 Angle of tool tip | | 0000 | G76 chamfer Len | 0000 |
| G76 Depth of minimum cutting | | -00.000 inch | G76 retreat | -00.000 inch |
| MPG Direction $\begin{matrix} X \\ Y \\ Z \\ S \\ X \\ Z \end{matrix}$ | | 0 | Graphic proportion | 0000.000 |
| G84 dwell at bottom time | | 000000 | Multi-purpose MPG 1:yes | 0 |
| G84 Acc/Dec fine tuning time | | 000000 | 0:Diameter 1:Radius | 0 |
| G83 buffer distancecg | | 0000.000 | Chuck type 0:in 1:out | 0 |
| Chuck locked delay time | | 000000 | Metric 0:mm 1:inch | 0 |
| Wait for SP speed reaching | | 0 | Screensaver 0:yes | 0 |
| MPG-test feedrate Num. | | 0000 | Restart.skip M98 1:yes | 0 |
| MPG-test feedrate Den. | | 0000 | Non-stop 0:no 256:yes | 000 |
| Restart,MTS G04 0:skip 1:run | | 0 | TLM function 0:open 1:close | 0 |
| Restart,block refetch 0:yes | | 0 | Edit omit decimal 1:yes | 0 |
| Remaining days | | 0000000 | Lamp yellow $\begin{matrix} 0:feed\ hold \\ 1:M02/M30 \\ 2:all \end{matrix}$ | 0 |
| Tapping Acc/Dec time (ms) | | 0000 | Corner connection $\begin{matrix} 1:G01/G03 \\ 2:G01/G02/G03 \end{matrix}$ | 0 |
| G41/G41 interference deal with 0/1/2 | | 0 | Use Y axis 1:yes | 0 |
| Coolant pump error | | | | |
| Back | Main | | SYSTEM MCM | VERSION G54..G59 |

Fig 4-1

MCM Parameters

The correct and proper setting of these parameters is important for operation of the mechanical system and fabrication of the work-piece. Make sure that the setting is correct. Press  to restart the machine when the MCM parameter is successfully set.

※ After pressing “F5-System Parameter” key in “User Parameter” page, the System Parameter page can be accessed; but it can be reviewed and cannot be revised, as per the figure below. To revise the system parameters, press “F7-Revise Parameter” key and then input system parameter password → initial value 123456

and you can revise the system parameters.

| PARAMETERS | X-AXIS | Y-AXIS | Z-AXIS |
|---|-----------|-----------|-----------|
| Resolution-Den.(pulse) | 0000000 | 0000000 | 0000000 |
| Resolution-Num.(pitch) | 0000000 | 0000000 | 0000000 |
| Traverse speed | 0000000 | 0000000 | 0000000 |
| Rotate direction | 0 | 0 | 0 |
| Home speed-1 | 0000000 | 0000000 | 0000000 |
| Home speed-2 | 0000000 | 0000000 | 0000000 |
| Home direction | 0 | 0 | 0 |
| Find grid direction | 000 | 000 | 000 |
| Distance of grid error | -0000.000 | -0000.000 | -0000.000 |
| Software OT(+) | -0000.000 | -0000.000 | -0000.000 |
| Software OT(-) | -0000.000 | -0000.000 | -0000.000 |
| MPG Den. | 0000000 | 0000000 | 0000000 |
| MPG Num. | 0000000 | 0000000 | 0000000 |
| Pitch err comp.(-1,0,1) | -0 | -0 | -0 |
| Pitch err segment length | 0000.000 | 0000.000 | 0000.000 |
| Backlash(G01) | 00.000 | 00.000 | 00.000 |
| Encoder direction | 0 | 0 | 0 |
| Pulse cmd width ^{2500k} _N | 0 | 0 | 0 |
| Grid offset | -000.000 | -000.000 | -000.000 |

Coolant pump error

| | | | | | | | |
|------|------|-----------------|--|---------|-------------|------------|------|
| Back | Main | Change password | | ALL MCM | Pitch Error | MCM Modify | PAGE |
|------|------|-----------------|--|---------|-------------|------------|------|

Fig. 4-2: System Parameter Page 1

| | | | | |
|-----------------------------|---|----------------------|--|---|
| Signal 0:NO1:NC 2:Disable | | | | |
| I00 EM-stop | 0 | I19 Z-Axis OT- | | 0 |
| I01 X home | 0 | I20 SP1 home signal1 | | 0 |
| I02 Z home | 0 | I21 SP1 home signal2 | | 0 |
| I03 X-axis error | 0 | I22 Spindle2 error | | 0 |
| I04 Z-axis error | 0 | I23 Spindle3 error | | 0 |
| I05 Spindle 1 error | 0 | I24 Y home | | 0 |
| I16 X-axis OT+ | 0 | I25 Y-axis error | | 0 |
| I17 X-axis OT- | 0 | I26 Y-axis OT+ | | 0 |
| I18 Z-axis OT+ | 0 | I27 Y-axis OT- | | 0 |
| I/O Function format setting | | | | |
| I16 X-axis OT+ | 0 | O09 Tailstock FOR | | 0 |
| I17 X-axis OT- | 0 | O10 Buzzer | | 0 |
| I18 Z-axis OT+ | 0 | O11 Bar feeder start | | 0 |
| I19 Z-Axis OT- | 0 | O12 Received Box | | 0 |
| I20 SP1 home signal1 | 0 | O13 Tailstock chuck | | 0 |
| I21 SP1 home signal2 | 0 | O14 Lamp YELLOW | | 0 |
| I22 Spindle2 error | 0 | O15 Lamp GREEN | | 0 |
| I23 Spindle3 error | 0 | | | 0 |

Y-axis OT-

| | | | | | | | |
|------|------|-----------------|--|--|--|------------|------|
| Back | Main | Change password | | | | MCM Modify | PAGE |
|------|------|-----------------|--|--|--|------------|------|

Fig 4-3 System Parameter Page 2

| PARAMETERS | X-AXIS | Y-AXIS | Z-AXIS |
|---|---------|-----------------------------------|---------|
| JOG speed | 0000000 | 0000000 | 0000000 |
| U,W max in execution | 000.000 | 000.000 | 000.000 |
| Arc compensation "+" | 0000 | 0000 | 0000 |
| Arc compensation "-" | 0000 | 0000 | 0000 |
| Arc compensation time(ms) | 0000 | 0000 | 0000 |
| Arc comp. function 1:cancel | 0 | Tool number(1~10) | 00 |
| Tool positioning delay(10ms) | 0000 | Tool change time(10ms) | 00000 |
| Wear direction | 0 | Max value of wear | 00.000 |
| Lubricate interval(s) | 000000 | Lubrication time(10ms) | 000000 |
| 0:row 1:electric 2:hydraulic | 0 | Tool carrier 0:after 1:before | 0 |
| Pulsec typc 0:P+D 2:AB | 0 | Full automatic 1:yes | 0 |
| G01 Acc/Dec time | 000000 | G00 Acc/Dec time | 000000 |
| G99 Acc/Dec time | 000000 | MPG Acc/Dec time | 000000 |
| Home setting ^{0:None 1:X 4:Z} _{2:Y 3:XYZ} | 0 | ATC reverse delay time | 000000 |
| Follow error checking ^{1:XYZ 2:XYZ} | 0 | Follow error value | 000000 |
| G92 A/D time of travel ending | 0000 ms | Dynamic Acc/Dec 1:yes | 0 |
| Exec. home after EM-stop 1:yes | 0 | ACC/Dec type 1:linear 2:S-curve | 0 |
| Monitor function 1:yes | 0 | Power off after servo alarm 1:yes | 0 |

Coolant pump error 000

| | | | | | | | | | |
|------|------|-----------------|--------|---------------|--------|--------------|------------|--------|------|
| Back | Main | Change password | BN-MCM | CLEAR ALL-PGM | LD-MCM | CLEAR OFFSET | MCM Modify | Unlock | PAGE |
|------|------|-----------------|--------|---------------|--------|--------------|------------|--------|------|

Fig 4-4 System Parameter Page 3

| | | | |
|------------------------------------|-----------------|-------------------------------|---------------|
| Tools number(1~10) | 00 | 0:Row 1:Electric 2:Hydraulic | 0 |
| Tool positioning delay | 0000 | Tool change time(10ms) | 00000 |
| Wear direction 0:"-" 1:"+" | 0 | Max value of wear | 00.000 |
| Lubricate interval(s) | 000000 | Lubrication time(10ms) | 000000 |
| Max rpm of chuck unclamp | 00000 | Screen saver 1:NO | 0 |
| Chuck type 0: Hydraulic 1: General | 0 | Y axis select 1:YES | 0 |
| Multi-MPG 0:NO 1:YES | 0 | Tool carrier 0:After 1:Before | 0 |
| Power on default 0:G99 1:G98 | 0 | Acc/Dec type | 0 |
| Pulse type 0:P+D 2:AB | 0 | G00 Acc/Dec time | 000000 |
| G01 Acc/Dec time | 000000 | MPG Acc/Dec time | 000000 |
| G99 Acc/Dec time | 000000 | SP voltage balance | -00.000 |
| MPG direction 0:↻ 1:↻ | 0 | Spindle number | 0 |
| Insert blank in the MDI | 0 | Home setting 0:None 1:↻ | 0 |
| Error count checking 0:NO 1:YES | 0 | G02/G03 sp fbk filter | 0000 |
| SIO filter constant(ms) | 0000 | Dynamic Acc/Dec 0:NO | 0 |
| Non-stop 0:NO 1:YES | 000 | Error count check value | 0000000 |
| SP1 chuck solenoid 0:one 1:two | 0 | ATC reverse delay time | 0000000 |
| MPG-test feedrate Num. | 0000000 | MPG-test feedrate Den. | 0000000 |
| 000 ▲ PAGE ▼ | | | |
| Back Main | Change password | BN-MCM | CLEAR ALL-PGM |
| | | LD-MCM | CLEAR OFFSET |
| | | MCM Modify | Unlock |

Fig 4-5 System Parameter Page 4

| | | | |
|-----------------------------|-----------------|-------------------------------|------------|
| 0:voltage 1:pulse | 0 | SP rotation direction | 0 |
| 0:open-loop 1:close loop | 0 | SP find grid 0:no 1:yes | 0 |
| SP acceleration time | 0000000 | SP search grid direction | 0 |
| SP deceleration time | 0000000 | SP positioning direction | 0 |
| SP manual rotation speed | 0000 | SP search home signal 1:yes | 0 |
| SP search grid speed | 0000 | SP encoder filter | 0 |
| SP positioning angle | -000.00 | SP positioning speed | 0000 |
| SP encoder(pulse) | 0000000 | SP search home speed | 0000 |
| SP command(pulse) | 0000000 | SP home shift | -000.00 |
| Spindle voltage balance | -00000 | SP encoder factor | 0 |
| SP max rpm at 10V | 0000000 | SP encoder direction | 0 |
| SP +10V slope speed | 0000000 | Chuck 0:hydraulic 1:general | 0 |
| SP -10V slope speed | 0000000 | SP chuck solenoid 0:one 1:two | 0 |
| SP distance of grid error | 0000000 | Power on default 0:G99 1:G98 | 0 |
| SP max rpm of chuck unclamp | 00000 | G02/G03 SP filter constant | 0000 |
| Power on default JOG speed | 00000 | SP stop after pro. end 1:yes | 0 |
| SP change into standard | | | |
| Resolution-Den.(pulse) | 0000000 | Travel speed | 0000000 |
| Resolution-Num.(pitch) | 0000000 | Acc./Dec. time | 0000 |
| Tapping type 0:G98 1,2:G99 | 0 | | |
| Coolant pump error ▲ PAGE ▼ | | | |
| Back Main | Change password | Spindle1 | Spindle2 |
| | | Spindle3 | MCM Modify |

Fig 4-6 System Parameter Page 5

| | | | |
|----------------------------|-----------------|--------------------------|------------|
| SP2 | | | |
| 0:voltage 1:pulse | 0 | SP rotation direction | 0 |
| 0:open-loop 1:close loop | 0 | SP find grid 0:no 1:yes | 0 |
| SP acceleration time | 0000000 | SP search grid direction | 0 |
| SP deceleration time | 0000000 | SP positioning direction | 0 |
| SP positioning angle | -000.00 | SP encoder filter | 0 |
| SP encoder(pulse) | 0000000 | SP positioning speed | 0000 |
| SP command(pulse) | 0000000 | SP home shift | -000.00 |
| Spindle voltage balance | -00000 | SP manual rotation speed | 0000 |
| SP max rpm at 10V | 0000000 | SP search grid speed | 0000 |
| SP +10V slope speed | 0000000 | SP encoder factor | 0 |
| SP -10V slope speed | 0000000 | SP encoder direction | 0 |
| SP change into standard | | | |
| Resolution-Den.(pulse) | 0000000 | Traverse speed | 0000000 |
| Resolution-Num.(pitch) | 0000000 | Acc./Dec. time | 0000 |
| Tapping type 0:G98 1,2:G99 | 0 | | |
| Coolant pump error | | | |
| Back Main | Change password | Spindle1 | Spindle2 |
| | | Spindle3 | MCM Modify |

Fig 4-7 System Parameter Page 6

| X-axis, compensation amount each segment | | | | | | | | | | | |
|--|---------|----|---------|----|---------|----|---------|--|--|--|--|
| 01 | -00.000 | 11 | -00.000 | 21 | -00.000 | 31 | -00.000 | | | | |
| 02 | -00.000 | 12 | -00.000 | 22 | -00.000 | 32 | -00.000 | | | | |
| 03 | -00.000 | 13 | -00.000 | 23 | -00.000 | 33 | -00.000 | | | | |
| 04 | -00.000 | 14 | -00.000 | 24 | -00.000 | 34 | -00.000 | | | | |
| 05 | -00.000 | 15 | -00.000 | 25 | -00.000 | 35 | -00.000 | | | | |
| 06 | -00.000 | 16 | -00.000 | 26 | -00.000 | 36 | -00.000 | | | | |
| 07 | -00.000 | 17 | -00.000 | 27 | -00.000 | 37 | -00.000 | | | | |
| 08 | -00.000 | 18 | -00.000 | 28 | -00.000 | 38 | -00.000 | | | | |
| 09 | -00.000 | 19 | -00.000 | 29 | -00.000 | 39 | -00.000 | | | | |
| 10 | -00.000 | 20 | -00.000 | 30 | -00.000 | 40 | -00.000 | | | | |

切削水泵異常

| | | | | | | |
|------|------|--------|--|--------|--|---------------|
| Back | Main | Z-AXIS | | Y-AXIS | | PAGE |
| | | | | | | MCM Modify |

Fig. 4-□ □-a□is Stud □rror Offset

| Y-axis, compensation amount each segment | | | | | | | | | | | |
|--|---------|----|---------|----|---------|----|---------|--|--|--|--|
| 01 | -00.000 | 11 | -00.000 | 21 | -00.000 | 31 | -00.000 | | | | |
| 02 | -00.000 | 12 | -00.000 | 22 | -00.000 | 32 | -00.000 | | | | |
| 03 | -00.000 | 13 | -00.000 | 23 | -00.000 | 33 | -00.000 | | | | |
| 04 | -00.000 | 14 | -00.000 | 24 | -00.000 | 34 | -00.000 | | | | |
| 05 | -00.000 | 15 | -00.000 | 25 | -00.000 | 35 | -00.000 | | | | |
| 06 | -00.000 | 16 | -00.000 | 26 | -00.000 | 36 | -00.000 | | | | |
| 07 | -00.000 | 17 | -00.000 | 27 | -00.000 | 37 | -00.000 | | | | |
| 08 | -00.000 | 18 | -00.000 | 28 | -00.000 | 38 | -00.000 | | | | |
| 09 | -00.000 | 19 | -00.000 | 29 | -00.000 | 39 | -00.000 | | | | |
| 10 | -00.000 | 20 | -00.000 | 30 | -00.000 | 40 | -00.000 | | | | |

切削水泵異常

| | | | | | | |
|------|------|--------|--|--------|--|---------------|
| Back | Main | Z-AXIS | | X-AXIS | | PAGE |
| | | | | | | MCM Modify |

Fig 4-□□-a□is Stud □rror Offset

| Z-axis, compensation amount each segment | | | | | | | | | | | |
|--|---------|----|---------|----|---------|----|---------|--|--|--|--|
| 01 | -00.000 | 11 | -00.000 | 21 | -00.000 | 31 | -00.000 | | | | |
| 02 | -00.000 | 12 | -00.000 | 22 | -00.000 | 32 | -00.000 | | | | |
| 03 | -00.000 | 13 | -00.000 | 23 | -00.000 | 33 | -00.000 | | | | |
| 04 | -00.000 | 14 | -00.000 | 24 | -00.000 | 34 | -00.000 | | | | |
| 05 | -00.000 | 15 | -00.000 | 25 | -00.000 | 35 | -00.000 | | | | |
| 06 | -00.000 | 16 | -00.000 | 26 | -00.000 | 36 | -00.000 | | | | |
| 07 | -00.000 | 17 | -00.000 | 27 | -00.000 | 37 | -00.000 | | | | |
| 08 | -00.000 | 18 | -00.000 | 28 | -00.000 | 38 | -00.000 | | | | |
| 09 | -00.000 | 19 | -00.000 | 29 | -00.000 | 39 | -00.000 | | | | |
| 10 | -00.000 | 20 | -00.000 | 30 | -00.000 | 40 | -00.000 | | | | |

切削水泵異常

| | | | | | | |
|------|------|--|--|--------|--|---------------|
| Back | Main | | | Y-AXIS | | PAGE |
| | | | | | | MCM Modify |

Fig 4-1□ □-a□is Stud □rror Offset

2 Description of Parameters

1 Basic Parameters :

For the cutting parameters of #1-#6 please refer to the description of respective G-Code # and under “M Code” of Chapter

1. Set Drilling Cycle Buffering Distance

Format #.#.#.# default value: #.#.#.#

When using #3 drilling command, the corresponding axis will move quickly from # for converting to the buffering distance setting of #1 feeding.

2. The ratio of the horizontal axis to axis in graph mode

Format#.#.#.#.#.#

This parameter is for setting the scale of the graph in the graph mode.

This parameter is an initial setting; for dynamic adjustment, you may press

PageUP/PageDown button in the graph screen for alteration.

3. Initial value generated by line number during program editing

Format #.# default value: #.#

When editing the program, the line number set for the first node system shall be "#1". If setting the parameter of this item as "#1", then the line number of the second node will be "#1#1".

4. The interval value obtained from setting the line number during program editing.

Format #.# default value: #.#

To set Item 3 as "#1" during program editing, such parameter will be set as "#1"; so the line number when inserting node 2 will be "#1#1", and that for node 3 will be "#1#1#1", and so on for the rest of the other nodes.

Setting the chuck movement (inner, outer clamp setting)

Format #.# default value: #.#

Setting #.#, loosen

Setting #.#1, tighten

This parameter is for specifying whether the chuck is loosened or tightened in a protruding action.

6. Working Count Upper Limit Setting

Format `#####` default value: `00`

If the working count range is set as “`0`”, then it means the counting limit will be ignored.

To execute the count, please add M15 in the working program placed at the end of each processed workpiece.

If receiving M15 Command when running the program, the system will add “1” to the number of the processed workpieces automatically. Upon reaching the upper limit set for the workpiece, the System will change to pausing status, reminding the customer that it has completed the set working count.

After reaching the upper limit count, the count arriving status can be cancelled by the following three methods:

- a. In Auto page, click the “`0`” key twice and the worked count will be cleared and set to zero.
- b. Restart the program. You may also clear and set the worked count zero in order to restart the counting.
- c. Press the Reset key and the count arriving status can also be cancelled and the worked count will be set to zero.

7. Time delay for chuck tightening

Format `####` default value: `50`, unit: `1ms`

If your key-in `05`, the time delay is: `50ms` `500ms`

This parameter is set to ensure that the chuck is securely clamped on the workpiece. In case the chuck fails to clamp the workpiece securely before executing the subsequent block, the setting needs to be increased.

8. Remaining Service Days

Such parameter is provided for reading instead of writing.

To remind the user to contact the machine manufacturing when the remaining service days are going to arrive.

- □ whether or not wait for spindle to reach full speed before performing a axial feed
Format □ □ □ default value: □ □

Setting □ □, proceed the subsequent block without waiting for the full speed of the spindle

Setting □ 1, proceed with the subsequent block after the spindle reaches full speed

For general cutting commands, a axial feed can be performed without waiting for the full spindle speed; for threading and drilling commands, to meet the technical criteria, it may demand the spindle to reach a steady speed before performing the cutting, therefore this parameter shall be set to 1, i.e., proceed with the subsequent block after the spindle reaches full speed

Setting this parameter to 1 affects the processing efficiency. Therefore the user must consider and weigh the relationship between the technical criteria and efficiency requirements for setting a proper value.

10. Radius or diameter programming

Format □ □ □ default □ □ □

Setting □ □, □-a□ is radius programming.

Setting □ 1, □-a□ is diameter programming.

Since general drawings indicate drills by its radius, setting this parameter to □ may facilitate the programming process. The customer may alter this parameter according to the actual requirements, so as to enable an easy and direct way for programming.

11. Manual Tool Change Rotation Direction Setting:

Format □ □ □ default value: □ □

Setting □ □, it means C□.

Setting □ 1, it means CC□.

The Turret service parameters can be based to set the rotating direction when the Turret is operated under Manual Mode.

Under Manual Mode, set this parameter to facility the site Tool change [e.g. for T1→T□] set as “1”□

To check if the “I Point” required for Tool change is working normally when performing the C and CC Tool change, you may set this parameter.

12. Omission of decimal point in programming

Format default value:

Setting, no omission of decimal point

Setting 1, decimal point omitted.

See 2.2.2.3 decimal point principles for details

13. If the Tool lifespan management function is active

Format default value:

Setting, it means start.

Setting 1, it means close.

If the user sets stricter service life for all tools used, it is suggested that this function should be activated in order to manage the tool and remind the timing for Tool change. After activating such function, the program will stop at T-Code when the Tool service time or the count is up.

14. Metric and imperial settings

Format default value:

Setting, metric system unit: mm

Setting 1, imperial system unit: inch

Setting of the measurement unit inch 25.4 mm when Setting 1, both the coordinates and tool compensation are displayed to the 4th digit after the decimal point.

15. Whether or not executing MTS at a re-start

Format default value:

Setting, skip

Setting 1, execute

This setting allows the user to select whether an MST code or a M4 command existing before the re-start block shall be executed or not when the program re-start function is enabled. The user may freely set this parameter based on actual needs.

When the parameter is set to “0”, the MTS 04 command before the re-start block will be omitted.

When the parameter is set to “1”, the MTS 04 command before the re-start block will be executed normally.

16. Whether a re-start skips M04
 Format 00 default value: 00
 Setting 00, do not skip
 Setting 01, skip

An M04 command call sub-program prior to the re-start block will be carried out normally if this parameter is set to 0.

An M04 command call sub-program prior to the re-start block will not be carried out if this parameter is set to 1.

17. Whether a re-start retrieves a prior block
 Format 00 default value: 00
 Setting 00, retrieve
 Setting 01, no retrieve

Set to “0” System retrieves a prior block when the re-start button is pressed. Program goes to the block prior to the re-start block and executes the prior block and the subsequent program.

Set to “1” System starts execution from the re-start block without retrieving the block prior to the re-start block.

18. Whether or not a smooth transit of tool-tip compensation is enabled
 Format 00 default value: 00
 Setting 00, yes
 Setting 01, no

When 041, 042 function is enabled (see 3.24.2), setting this parameter to 1 will cause the tool-tip outside compensation to disable arc compensation and take a line compensation.

19. Setting for handling interference concerning 041/042
 Format 00 default value: 00
 Setting 00, issue alarm without execution

Setting 1, automatically optimize trace to avoid interference

Setting 2, execute without issuing an alarm

In case of interference during the tool-tip compensation command #41, #42, you may set this parameter to select the handling method. (See 3.24.2 for details of this setting)

2. Parameter

- 20. Denominator of Machine Resolution, mm
- 21. Numerator of Machine Resolution, mm
- 22. Denominator of Machine Resolution, mm
- 23. Numerator of Machine Resolution, mm
- 24. Denominator of Machine Resolution, mm
- 25. Numerator of Machine Resolution, mm

The value of resolution numerator or denominator is set according to the specification of Axial Transmission Device (e.g. Guide Screw) and the pulse count returned by the Servo Motor. Generally speaking, the speed (voltage) control type is set according to the pulse count returned by the Servo Motor; whereas, the position (pulse) control type is set by the pulse count after the Motor rotates for one round. After being confirmed, do not attempt to adjust unless instructed.

Speed Control Type

$$\text{Resolution} = \frac{\text{Guide Screw Pitch}}{\text{Motor Encoder} \times \text{Multiple}} \times \text{Tooth Count Ratio}$$

Position Control Type

$$\text{Resolution} = \frac{\text{Guide Screw Pitch}}{\text{Motor 1-round Pulse Count}} \times \text{Tooth}$$

Example 1 Speed Control Type

mm Guide Screw Pitch 5.000mm

Motor Encoder 2500 pulse; Multiple 4

Tooth Count Ratio 5:1 (5 rounds for Servo Motor, 1 round for Guide Screw)

$$\begin{aligned} \text{Resolution} &= \frac{5000}{2500 \times 4} \times \frac{1}{5} \\ &= \frac{1}{10} \end{aligned}$$

- axis Resolution: Denominator Set Value □ 1
- axis Resolution: Numerator Set Value □ 1

Example 2 Position Control Type

- axis Guide Screw Pitch □ 5.000mm
- Motor 1-round Pulse □ 10000 pulse
- Tooth Count Ratio 5:1 □ 5 rounds for Servo Motor, 1 round for Guide Screw

$$\begin{aligned} \text{Resolution} &= \frac{5000}{10000} \times \frac{1}{5} \\ &= \frac{1}{10} \end{aligned}$$

- axis Resolution: Denominator Set Value □ 1
- axis Resolution: Numerator Set Value □ 1

26. Set axis traverse speed limit
 Format : □□□□ , Unit: mm/min (default) □□□□□□
 Note : The format is only for integer.

The traverse speed limit can be calculated from the following equation:

$$F_{max} = \frac{RPM}{Pitch} \times R$$

- RPM : The ratio. rpm of Servo Motor motor
- Pitch : The pitch of the ball-screw
- R : Gear ratio of ball-screw/motor

Example: Max rpm □ 3000 rpm for □-axis, Pitch □ 5 mm/rev, Gear Ratio □ 5/1
 $F_{max} = \frac{3000 \times 5}{5} = 2500 \text{ mm/min}$

- 27. Direction of Motor Rotation, □-axis
- 28. Direction of Motor Rotation, □-axis
- 29. Direction of Motor Rotation, □-axis

Format : , default

Setting , Motor rotates in the positive direction. C

Setting 1, Motor rotates in the negative direction. CC

This MCM can be used to reverse the direction of motor rotation if desired. So you don't have to worry about the direction of rotation when installing motor. These parameters will affect the direction of OM position

30. Homing speed-1

31. Homing speed-1

32. Homing speed-1

Format default value: 25, unit: mm/min

In the homing process, the speed for an axial movement from the current position to the position where the origin-switch is touched.

33. Homing speed-2

34. Homing speed-2

35. Homing speed-2

Format default value: 4, unit: mm/min

The speed the feedback device searches for zero after the axial position leaves the origin-switch in the homing process.

Items requiring the attention of the user; in the homing process, the machine moves toward the origin-switch with the first-stage speed, the length of the origin-switch must be longer than the deceleration distance, otherwise the machine will exceed the proximity switch and this results in a OMI error.

The formula and an example for calculating the length of origin-switch are as follows:

Length of origin switch \geq FDCOM ACC6

- Note: ① FDCOM First-stage speed of homing
 ② ACC Accelerate/ decelerate time of 1
 ③ 6msec 6s 1msec 6msec

□□: F□COM, First-stage speed of homing □ 3□□□mm/min
 ACC, Accelerate/ decelerate time □ 1□□ms, then
 Minimum length of origin-switch □ 3□□□ □ 1□□□□6□□□□ □ 5 mm.

36. □-□oming direction

37. □-□oming direction

38. □-□oming direction

Format □□ □default value: □□

Setting □□, Tool returns to machine origin along positive direction of coordinate.

Setting □ 1, Tool returns to machine origin along negative direction of coordinate.

Set this parameter to adjust the homing direction if the user finds the homing direction is not correct.

3□. The direction that Servo Motor motor search the □rid when □-a□ is going back to □OM□.

40. The direction that Servo Motor motor search the □rid when □-a□ is going back to □OM□.

41. The direction that Servo Motor motor search the □rid when □-a□ is going back to □OM□.

Format □□□□ □default value: □□, Scope: □ 1, 12□, 256.

Taking □-a□ is for example:

Setting □□: Means when □-a□ is Motor returns to machine's □ome Position □□OM□□, the direction for Section-2 to leave □imit Switch and for Section-3 to find □ero point □□RI□□ will be opposite to Section 1; whereas, the direction for Section-2 to leave □imit Switch and for Section-1 to find □ero point □□RI□□ will be the same, as per Fig. 4-11 □□□

Setting □1: Means when □-a□ is Motor returns to machine's □ome Position □□OM□□, the direction for Section-2 to leave the □imit Switch will be consistent with that for Section-1; whereas, the direction for Section-3 to find □ero-point □□RI□□ will be opposite to that for Section-1 and Section-2, as per Fig. 4-11 □C□

Setting □12□: Means when □-a□ is Motor returns to machine's □ome Position □□OM□□, the direction for Section-2 to leave the □imit Switch will be opposite to that for Section-1; in the meantime, the

direction for Section-3 to find RI will also be opposite that for Section-2 to leave the Limit Switch, as per Fig. 4-11

Setting 256: Means when -axis Motor returns to machine's Home Position (OM), the directions for Section 1, Section-2 and Section-3 will all be the same, as per Fig. 4-11 (A)

The speed for returning to OM will be divided into the following 3 sections as per Fig. 4-11

Section-1 Speed: Set in "OM Return Speed 1" system parameter and the direction will be set in "OM Return direction".

Section-2 Speed: When the speed of Section 1 is reduced to "1", the speed of Section 2 will be set as 1/4 of that for Section 1; and its direction will be determined according to the value contained in the system parameter of "Encoder Find Zero direction".

Section-3 Speed: Used for finding the speed of zero-point RI for Feedback device, which will be set by the System Parameter of "OM Return Speed 2"; its direction will be determined according to the value contained in the system parameter of "Encoder Find Zero direction".

The customer must notice that when returning to OM, the machine will move towards the Limit with Section-1 speed and the length of said Limit must be longer than the deceleration distance otherwise, the machine will overshoot the Limit Switch and generate incorrect OM-returning phenomenon.

Listed below is the example explaining Limit Switch length calculation formula and calculation method:

$$\text{Limit Switch Length} \geq \text{FDCOM} + \text{ACC} + 6$$

- Note: ① FCOM Section-1 speed for returning to OM.
 ② ACC ACC1 acceleration/deceleration time
 ③ 6msec 6sec 1 6msec

Example: FCOM OM-returning Section-1 speed: 3mm/min
 ACC plus ACC time 1ms, then,
 Limit Switch min. length 3 + 1 + 6 = 5 mm

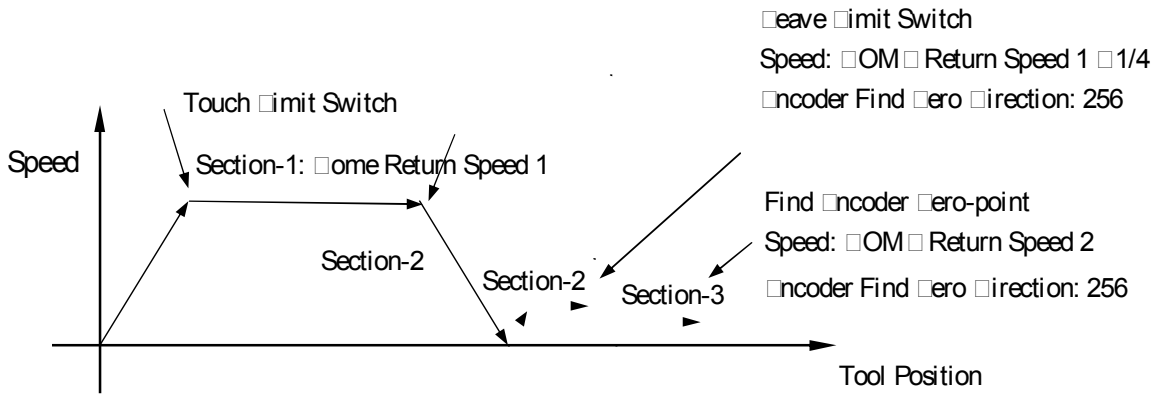

Fig. 4-11 A OM Return Speed and Find Encoder Direction

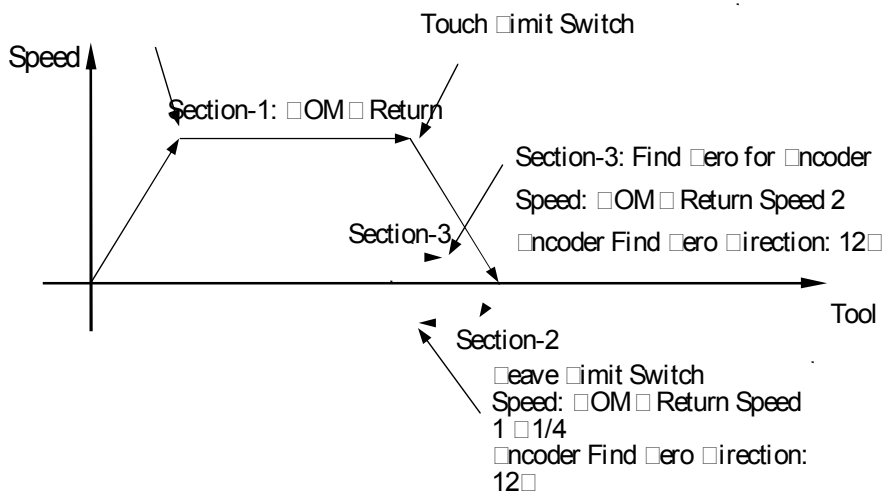

Fig. 4-11 B Machine OM Return Speed and Find Encoder Direction

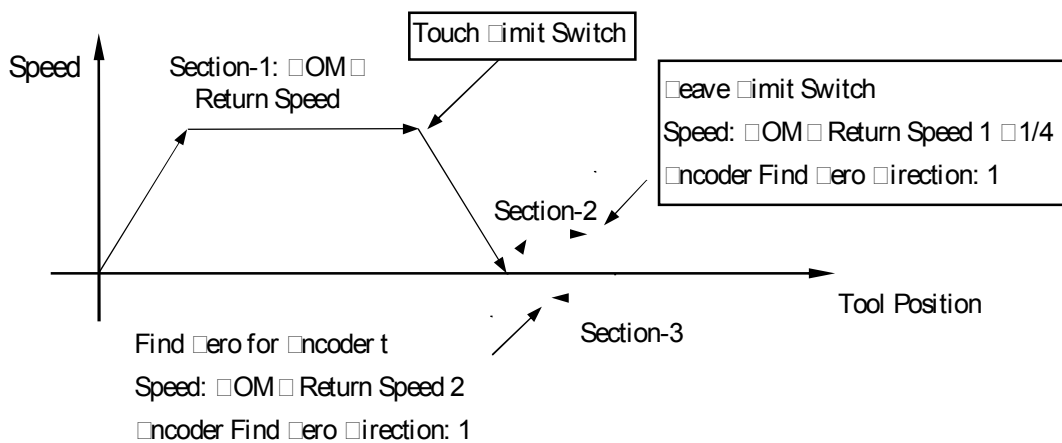

Fig. 4-11 C Machine OM Return Speed and Find Encoder Direction

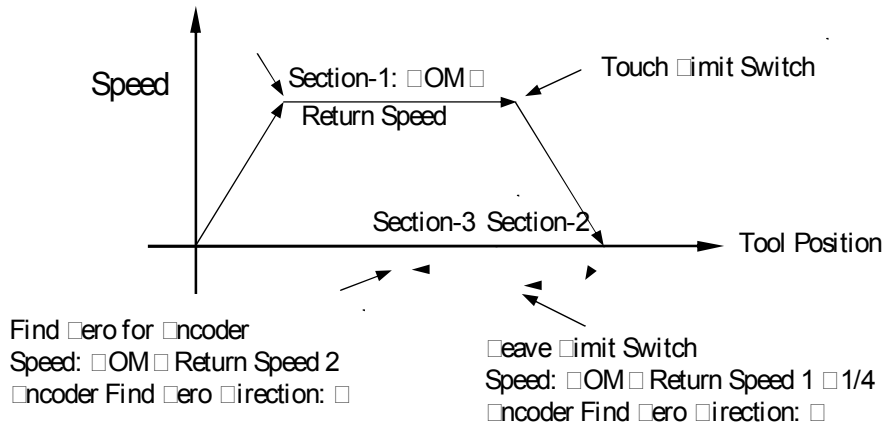

Fig. 4-11 Machine OM Return Speed and Find zero RI direction

- 42. a is Encoder Find zero-Point Max distance
- 43. a is Encoder Find zero-Point Max distance
- 44. a is Encoder Find zero-Point Max distance

Format: ; Unit: mm

Scope: mm

Max distance limit for Servo Motor to find the grid signal.

Example: If the distance after a is Servo Motor turns for 3/4 round is 5. mm, then Parameter 42 will be 5.2.

Note If the Servo Motor fails to find out the grid point after reaching the set scope then the system will display “1” alarm message.

- 45. Software OT limit in direction, a is.
- 46. Software OT limit in direction, a is.
- 47. Software OT limit in direction, a is.

Format : , Unit: mm/min default: .

Set the software over-travel (OT) limit in the positive direction, the setting value is equal to the distance from positive OT location to the machine origin OM.

- 48. Software OT limit in direction, a is.
- 49. Software OT limit in direction, a is.
- 50. Software OT limit in direction, a is.

Format : , Unit: mm/min default: - .

Set the software over-travel (OT) limit in the negative direction, the setting value is equal to the distance from negative OT location to the machine origin (M-OM).

Travel Limit Concept and Description

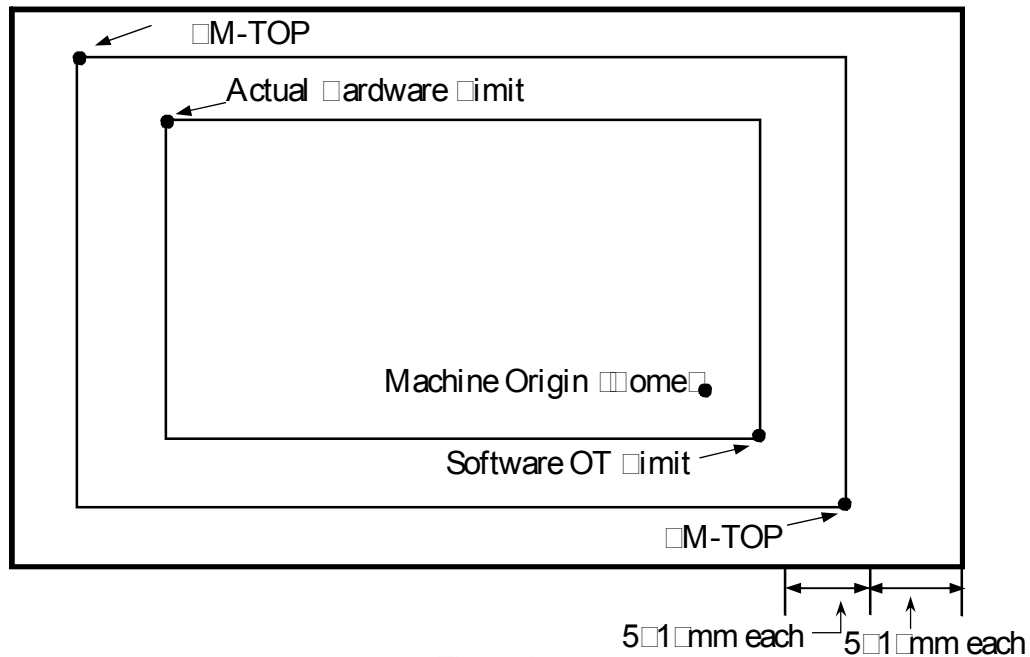

Fig. 4-12

Note The software travel limit setting point is approximately 1mm to M-TOP

1. a is denominator, MP and-wheel Resolution Adjustment. pulse
2. a is numerator, MP and-wheel Resolution Adjustment. μm
3. a is denominator, MP and-wheel Resolution Adjustment. pulse
4. a is numerator, MP and-wheel Resolution Adjustment. μm
5. a is denominator, MP and-wheel Resolution Adjustment. pulse
6. a is numerator, MP and-wheel Resolution Adjustment. μm

Format : , default 1

Example: If Item 51 Parameter 1; Item 52 Parameter 1; and and heel Multiple is 1, then,
 and heel moving for 1 frame 1 Pulse
 and a is Feed distance 1 (1) 1mm

7. Max value of U, tool compensation can be entered during the operation
 Format : . default value: 2., Max value is 2., unit: mm

Alteration of tool compensation data during the operation can only be made with incremental method. This parameter is used to set a maximum value for preventing tool collision.

Setting value 0.000, denotes no alteration of tool compensation data during the operation.

- 8. Pitch Error Compensation Mode Setting, axis.
- 9. Pitch Error Compensation Mode Setting, axis.
- 60. Pitch Error Compensation Mode Setting, axis.

Format: , default

Setting 0, Compensation canceled.

Setting -1, Negative side of compensation.

Setting 1, Positive side of compensation.

Note: The screw offsetting will be allowed only one direction at a time.

| axis | axis | axis | Explanation |
|------|------|------|--|
| 0 | 0 | 0 | Compensation cancel |
| -1 | -1 | -1 | No compensation when tool is on the side of the reference point |
| 1 | 1 | 1 | No compensation when tool is on the side of the reference point. |

- 61. Segment length for Pitch Error Compensation, axis
- 62. Segment length for Pitch Error Compensation, axis
- 63. Segment length for Pitch Error Compensation, axis

Format: . , default, Unit mm

Note: The offset value of each section will be entered by pressing “Screw Offset” soft key, and at most 4 sections will be allowed as per Fig. 4-4, 4-4, 4-1.

- The length setting scope of each section for offsetting the error of screw pitch will be 2~4 mm.
- When the setting of offset length is below 2 mm, then the length shall be set at 2 mm.
- The offset setting means the **incremental value**, which can be expressed either in positive or negative manner. If the offset section count is less

than 4 sections, then the parameter of the remaining sections must be set at zero.

Example: Assuming the total length of the axis screw is 1m (1000mm) and where it will be divided into 10 sections for offsetting:

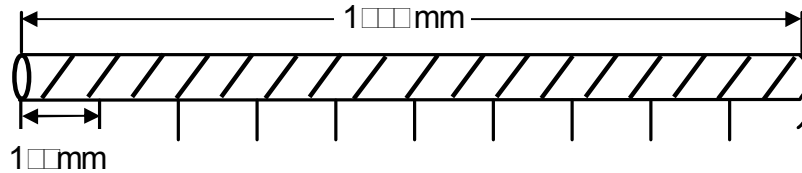

Fig. 4-13

Therefore, the average length of each section is 100mm. It means that the set value of “Axis Screw Pitch Error Offset per Distance Section” is 100000, in which, the offset of each section is set by parameter items as per Fig. 4-13, Section 0101 and Section 1104 must be set as zero.

64. Spindle type (Re-start enabled)
 Format 00 (default value: 00)
 Setting 00, Voltage type spindle
 Setting 01, Pulse type spindle

User may make corresponding settings according to the actual control of spindle.

65. Set Loop Open/Close Control Method (Restart available)
 Format 00 (default value: 00)
 Setting 00: Spindle open loop control.
 Setting 01: Spindle closed loop control (Spindle alignment control)
 For the Spindle of Inverter, such parameter shall be set as “0”.

For the Spindle of Voltage-type Servo Motor, such parameter can be set according to the wiring method (see 5-15, 5-16).

For the Spindle of Pulse-type Servo Motor, such parameter would be meaningless.

66. Set Spindle Acceleration/Deceleration Time
 Format 0000 (default value: 100, using “ms” as the unit)
 Setting Scope: 20300ms.

Such parameter must be set according to actual characteristics of the machine, and it can be observed through manual Spindle starting and stopping. The said parameter shall be measured to see if it is appropriately set according to the indicators such as if the Spindle is smooth during starting and if it can stop stably during the stopping process.

Note: Described below is the setting of acceleration/deceleration time, which must be executed according to the actual characteristics of the machine. After modifying the parameter, it is also necessary to observe if the operating mechanism is working stably and smoothly during the starting and stopping process. As for the Spindle of the Inverter, because the Spindle acceleration/deceleration time is adjusted by the Inverter, so it is needed to set such parameter at the minimum value, i.e. 2.

67. Setting of spindle speed at 100 voltage

Format 0000 (default value: 3000, unit: RPM)

For a variable-speed spindle, this parameter is used to adjust the linear relationship between the spindle rpm and the voltage.

68. Setting of rotation direction of spindle

Format 00 (default value: 00)

Setting 00, for positive rotation

Setting 01, for negative rotation

69. Set Manual Spindle Speed

Format 0000 (default value: 10, using "RPM" as the unit)

Such parameter can be used to set the Spindle logging speed under Manual Mode.

70. Setting of searching for RI point

Format 00 (default value: 00)

Setting 00, search for RI point (encoder signal in -phase)

Setting 01, no search for RI point (encoder signal in -phase)

For a voltage type open-circuit spindle, the motor needs not to search for the RI point (encoder signal in -phase); for pulse type spindle and voltage type closed-circuit spindle, this parameter can be set according to actual needs.

71. Setting of rotation direction of spindle for search of \square RI \square point

Format $\square\square$ default value: $\square\square$

Setting $\square\square$, Positive rotating direction

Setting \square 1, Negative rotating direction

Use this parameter to set the rotation direction of motor for search of \square RI \square point
 \square encoder signal in \square -phase \square

72. Setting of spindle rpm for search of \square RI \square point

Format $\square\square\square\square$ default value: 1 \square unit: RPM

Use this parameter to set rotation speed of motor for search of \square RI \square point
 \square encoder signal in \square -phase \square

73. Setting of spindle orientation

Format $\square\square$ default value: $\square\square$

Setting $\square\square$, Positive rotating direction for spindle orientation

Setting \square 1, Negative rotating direction for spindle orientation

Use this parameter to set the rotating direction for spindle orientation in manual mode.

74. Setting of rotation speed of spindle orientation

Format $\square\square\square\square$ default value: 1 \square Unit: RPM

Use this parameter to set rotation speed for spindle orientation in manual mode.

- 7 \square . Set if to find the Spindle \square OM \square signal

Format $\square\square$ default value: $\square\square$

Setting $\square\square$: Quit finding Spindle \square OM \square Switch signal

Setting \square 1: Find Spindle \square OM \square Switch signal

\square hen setting the parameter as “1”, it means the finding of \square ternal \square OM \square Switch signal of the Spindle is required. In this case, please install the \square ternal \square OM \square Switch.

76. Set to find the speed of Spindle \square OM \square signal

Format $\square\square\square\square$ default value: \square using “RPM/Min” as the unit \square

Set the RPM of Spindle when finding the e \square ternal \square OM \square Switch.

77. Setting of spindle origin offset

Format `###.##` default value: `00`

Set value of deviation of spindle origin

In case the position of machine origin when the spindle is assembled deviates from the ideal position to the customer, this parameter may be used for adjustment.

78. Setting of number of spindle feedback pulses

Format `#####` default value: `4060`

Sets number of feedback pulses per revolution of spindle based on the number of spindle encoding lines.

79. Setting of number of pulses in the spindle command

Format `#####` default value: `4060`

Sets number of pulses to be generated by controller when spindle turns one revolution.

Example: For a servo spindle with a gear mechanism having a gear ratio of 3:4, i.e., spindle rotates 4 turns when motor rotates 3 turns, the servo spindle rotates 1 turn when receiving a pulse command of 10000.

In the above example, spindle rotates 1 turn when the spindle motor rotates 75 turns, meaning that the controller only needs to send out 7500 pulses for the spindle to rotate 1 turn. Therefore, the parameter shall be set to 7500 instead of 10000. Since the servo spindle encoder is installed at the electric machinery end, therefore the number of pulses in the spindle feedback shall also be set to 7500. For the above conditions, suppose the encoder is installed at the spindle end instead of the electric machine end, and the encoder is of 1024 lines, then the number of pulses in the spindle feedback shall be set to 4060 \times 4 \times 1024.

80. Setting of number of tools

Format `##` default value: `00`

Used in combination with powered turret, maximum 10 tools.

81. Set up the Turret type by the actual condition of the machine

Format □□ □ default value: □□

Setting □□ Tool Row

Setting □1: □lectrical Turret

Setting □2: □ydraulic Turret

Setting □3: □lectrical Turret 2

82. Setting of Tool positioning delay

Format □□□□ □ default value: 1□, unit: 1□ms□

□efault setting is 1□, i.e., 1□ms.

In the event of miss-positioned tool change, properly increase this parameter setting and observe if the tool change is better positioned.

83. Tool Change monitoring time setting

Format□□□□ □ default value: 2□□, using “1□ms” as the unit□

Such parameter is used to monitor the time consumed during the entire Tool change process. If the actual Tool change time exceeds the set value of such parameter, then the screen will indicate “Tool Change Overdue” alarm signal. To remove the alarm, please refer to the function alarm described in Chapter 6.

84. Setting of wear direction

Format □□ □ default value: 1, positive□

Setting □□, negative direction

Setting □1, positive direction

User may make adjustment according the used direction for making compensation for the wear.

85. Setting of maximum value of tool compensation

Format □□.□□□ □ default value: 2.□□□; maximum value is 2□□□□, unit: mm□

This setting is used for setting an upper limit for the tool compensation when the program is not in execution. In case exceeding the upper limit, an alarm “protection limit exceeded” will be issued.

86. Setting of Lubrication interval

Format □□□□□□ □ default value: 1□□□, unit:1s□

87. Setting of Lubrication duration

Format `G000000` default value: 1000, unit: 1ms

88. Set the maximum rpm at which the chuck can be moved

Format `G000` default value: 100, unit: rpm

Range: 0050rpm

00:

A subsequent block to an M05 Spindle Stop command is M10 Chuck Loosen command in the program; if this parameter is set as "100", the chuck can be loosened when the spindle decelerates to 100rpm; if the parameter is set as "0", the chuck can only be loosened until the spindle comes to a full stop.

For a lathe furnished with an automatic material dispenser, adjusting this parameter may increase the process efficiency.

89. Whether or not to enable the screen saver

Format `G00` default value: 00

Setting 00, enable

Setting 01, disable

When screen saver is enabled, the screen automatically enters sleep mode when the controller remains untouched for 10 minutes, for prolonging lifespan of the screen. Pressing any key will resume the display.

90. Set the type of Chuck Disc according to the actual conditions of the machine

Format `G00` default value: 00

Setting 00: Hydraulic Chuck Disc

Setting 01: Ordinary Chuck Disc

91. If to start axis

Format `G00` default value: 00

Setting 00: No start

Setting 01: Start

92. If to start Multi-function and heel

Format `G00` default value: 00

Setting 00: No start

Setting 01: Start

When setting as “1” for starting the Multi-function and heel, the adjustment of and heel multiple and the selection of axis will be determined by pressing the Multi-function and heel multiple selection and axis selection key.

3. Retention

4. Setting of default feed mode at start-up

Format default value:

Setting, feed per revolution

Setting 1, feed per minute

If is the default mode, decimal point is not allowed in the F value. If F value is set for pitch, add 3 “” to the end, Input of F5 indicating the pitch value is 5 mm

If is the default mode, decimal point is allowed behind F.

5. Setting of tool support type

Format default value:

Setting, rear support

Setting 1, front support

User may set according to actual tool position. See description of pair-tools for details about front and rear tool supports.

6. Setting of type of pulse type

Format default value:

Setting, pulse direction

Setting 1, positive/negative pulse

Setting 2, A/ phase

Setting of this parameter requires setting of servo parameters, for matching with pulse type generated by the pulse generator.

Suggest that the user shall set this parameter to “2, A/ phase”

7. Setting of acceleration/deceleration type

Format default value: 1

Setting, logarithm type

Setting 1, linear type

Setting 2, S-curve type

If no special requirement is raised for acceleration/deceleration, it is suggested to set this parameter to “1”.

8. Setting of acceleration/deceleration time constant

Format $\square\square\square\square\square\square$ default value: 1, unit: milli-second [ms]

Setting range: 2³ms.

9. Setting of acceleration/deceleration time constant

Format $\square\square\square\square\square\square$ default value: 1, unit: milli-second [ms]

Setting range: 2³ms

100. Setting of acceleration/deceleration time constant

Format $\square\square\square\square\square\square$ default value: 1, unit: ms

Setting range: 2³ms, suggest to set both and to 1.

101. Setting of MP acceleration/deceleration time

Format $\square\square\square\square\square\square$ default value: 64, unit: ms

Setting range: 2³ms.

Setting of motor acceleration/deceleration time in handwheel mode, suggested setting value is 15.

102. Retention

103. Setting of spindle voltage zero correction value

Format $\square\square.\square\square\square$ default value: 0, unit: mv

Range: - $\square\square.\square\square\square\square\square\square.\square\square$

Adjusts spindle voltage zero effective in open-circuit

If system output is about -0.1 at system speed S , then voltage zero parameter is: $20.1 - 1 - 1/24$. Adjust output voltage to be as close to 0 as possible at system speed S . This parameter is normally set to 21.

0: For adjusting spindle speed by inverter

1. First adjust this parameter so that output voltage is closest to 0 when the rpm is zero.

2. Adjust the system parameter “Spindle RPM at 1” in the controller end screen to a rational value, so that the linear alteration of spindle speed meets the site requirements.

The above operation is for providing the user with a general method. For the substantial inverter, the user may use these parameters freely to adjust the speed.

104. Setting of handwheel direction

Format default value:

Setting , , .

Setting 1, -, .

Setting 4, , -.

Setting 5, -, -.

If the handwheel has a wrong direction after connecting the wires, use may alter the direction by setting this parameter.

105. Set Spindle Count

Format default value: 1; Max value: 3

Spindle 1 → C-Axis Connector

Spindle 2 → A-Axis Connector

Spindle 3 → -A Axis Connector

106. If to insert space in the displayed code

Format default value:

Setting es

Setting 1: o

Example: In the editing program under 1 line number, the Spindle performs C rotation at 1000RPM per minute. If setting this parameter as “”, then “ 1 M3 S1000” will be displayed, with space between the line number and the respective command code:

If setting as “1”, then “ 1M3S1000” will be displayed, without space between the line number and the respective command code:

107. Axis setting for returning to HOM

Format default value:

Bit ----- -A Axis o HOM return; 1: OM return

it1-----A is o OM return; 1: OM return

it2-----A is o OM return; 1: OM return

For example:

Setting 0: every axis will not return to OM.

Setting 1: A axis is returning to OM.

Setting 4: A axis is returning to OM.

Setting 5: /A axis is returning to OM.

108. Retention

10. Sensitivity of spindle RPM sensor

Format 0000 (default value: 1)

The spindle feedback filter is constant when executing an arc cutting in the mode

For a setting 0, filter is not active. System performs a re-calculation immediately as long as a change occurs in the number of spindle feedback pulses.

For a setting n, system performs a re-calculation only when the number of feedback pulses exceeds n.

110. Setting for enabling detection against error follow

Format 0 (default value: 0)

Setting 0, disable

Setting 1, enable

For pulse type motors, this function shall be enabled to detect servo motor follow error; however the error limit shall be set according to machine conditions.

Enabling this function can effectively protect the machine against over-travel resulting from a servo error.

111. Setting of follow error

Format 000000 (default value: 45)

A Follow error is defined as the difference between the position of the controller command and the position of the actual servomotor feedback.

Servo follow error setting value, an RROR 2 alarm will be issued.

112. SIO Filtration Parameter Setting

Format □□□□ default value: □ using “ms” as the unit□

□□□□ Example: If setting this parameter as “□”, then the “I-Point” signal with continuous time less than □ms will not respond. Such parameter is mainly used to resist the noise interference.

For the □lectrical Turret or □ydraulic Turret, it is preferably to set the parameter as “2” in order to assure that the system can □uickly respond to the IO signal of the Turret.

113. □nabling special acceleration/deceleration form

Format □□ default value: □□

Setting □□, disable

Setting □ 1, enable

□nabling the special acceleration/deceleration form allows further enhancement in the acceleration/deceleration efficiency based on the linear type, s-curve type and exponential type acceleration/deceleration curves, therefore elevating the execution efficiency.

In case the user finds that the efficiency of the machine is not enough during the process, he may reach his aim by disabling parameters such as “wait for spindle to reach full speed before performing a □ial feed” and “□nabling special acceleration/deceleration form”.

114. Turning Corner Round Angle Connection

Format □□□□ default value: □□

□□ Set the Servo Motor acceleration/deceleration type to C□C standard mode.

256 □ Set the round angle connection between each □ode.

11□. □lectrical Magazine CC□ □elay □1□ms□

Format □□□□□ default value: 1□□, using “1□ms” as the unit□

It is used to set the time delay re□uired for locking the CC□ action of the □lectrical Magazine.

116. Spindle 1 Chuck 1-□ay/2-□ay Solenoid □alve

Format □□ default value: □□

□□ 1-□ay Solenoid □alve

In this case, the Spindle Chuck action is controlled by O independently.

I 2-way Solenoid valve

In this case, the Spindle Chuck action is jointly controlled by O and O5.

117. and heel Test Feed Rate numerator

118. and heel Test Feed Rate denominator

Format default value: 1

It is used to adjust the fast/slow program feed rate when testing the and heel.

Parameter for setting the spindle to standard axis

119. Set the Rotation direction

Format default value:

Setting Forward direction

Setting 1: Reverse direction

120. Set the Acceleration/Deceleration Time

Format default value: 1, using "ms" as the unit

Setting Scope: 43ms

121. Maximum feed speed

Format default value: 1, unit: mm/min

Note: Setting value shall be an integer without a decimal point.

e.g.: Setting 5, indicates a maximum axis feed rate of 5mm per minute.

Limit of max feed speed is calculated as follows:

$F_{max} = \frac{3000}{5} \times \text{Axial servomotor max speed} \times \text{axial pitch} \times \text{gear ratio}$

e.g.: axis servomotor max speed is 3000 rpm, guide screw is 5 mm, gear ratio is 5 : 1 (servomotor turns 5 revolutions, guide screw turns 1 revolution)

$F_{max} = \frac{3000}{5} \times 5 \times 5 = 250$. Recommended setting is 250.

122. Set Spindle Encoder Multiple

Format default value: 4

Setting 1: Means feedback signal multiplied by 1.

Setting 2: Means feedback signal multiplied by 2.

Setting 04: Means feedback signal multiplied by 4.
Only one of the said three values can be selected.

123. Spindle feedback direction

Format 00 default value: 00

Setting 00, feedback in positive direction

Setting 01, feedback in negative direction

In case the spindle speed indication displays normal but spindle position displays abnormal, try to alter this parameter from “0” to “1”, see if the position becomes accurate.

124. Set Resolution denominator

Format 00000000 default value: 4096

125. Set Resolution numerator

Format 00000000 default value: 36000

Example

Assuming C-axis is the rotating axis and the angle when rotating for one round is 360 degrees.

Motor encoder 1024 Pulse in multiple 4, and the Spindle feedback pulse count must be set as “4096”.

Tooth Count Ratio: 5:1 every 5 rounds of Servo Motor rotation will drive C-axis to rotate for 1 round.

$$\begin{aligned} \text{Resolution} &= \frac{36000}{1024 \times 4} \times \frac{1}{5} \\ &= \frac{36000}{4096} \end{aligned}$$

C-axis Resolution denominator Set value 4096

C-axis Resolution numerator Set value 36000

126. Spindle Feedback Filtration Frequency Setting

Format 00 default value: 00

Setting 00: Filtration frequency is 50000

Setting 01: Filtration frequency is 75000

Setting 02: Filtration frequency is 100000

Setting 3: Filtration frequency is 342

When setting the corresponding feedback filtration frequency according to the Spindle Encoder setting, the System will be able to prevent the noise interference effectively.

Example: If setting the parameter as “3” and Spindle Encoder as “124” with 4 times multiple, then the Spindle can reach 5000 RPM of maximum speed. Note: $342 \times 4 \times 124 = 5000 \text{ RPM} / 6 \text{ sec}$

If setting Spindle Encoder as “2500” and requiring the Spindle to reach 3000 RPM of maximum speed, then such parameter must be set as “3”, i.e. $5000 \times 3 = 15000$. In this case, $15000 \times 124 = 2500 \times 3000 / 6$.

The customer can set such parameter at moderate value according to the Spindle Encoder installed for the machine and the required maximum Spindle speed.

127. Retention.

128. Set 1 Tooth Gap Offset

Format: [].[] (default value: 0) using “mm” as the unit

Scope: -[.][] mm, which can be used to remove the reverse gap of the stud.

When performing reverse action, certain gaps may exist in the stud. In this case, such parameter can be used to make correction.

129. Axis Feedback Direction Setting

Format: [] (default value: 0)

Setting 0, means the forward feedback direction.

Setting 1, means the reverse feedback direction.

It is mainly used to set the feedback direction of []/[]/[] axes in order to save the trouble of line change.

Note: If the axis rotation direction is set at “1”, it is necessary to change such parameter as “1” to avoid confusing the feedback signal.

130. Feedback Filtration Frequency Setting

Format: [] (default value: 0)

Setting 0, means the Filtration Frequency is 5000

Setting 1, means the Filtration Frequency is 7500

Setting 02, means the Filtration Frequency is 1000000

Setting 03, means the Filtration Frequency is 342000

When setting the appropriate feedback filtration frequency according to the axis encoder, the System will be able to prevent the noise interference effectively. For detailed content, please refer to the parameter description under Item 123.

131. Setting of pulse-width command 2.5 M/n or 25000/n

Format 00000000 default value: 50

00 : Setting 05, speed of pulse command is 5000PPS (25000/50)

Setting 04, speed of pulse command is 6250PPS (25000/40)

132. Axis Manual Speed (mm/min)

Format 00000000 default value: 1000 mm/min

The parameter is used to set the speed for driving the axis when operated under Manual Mode.

133. 1300-axis find (rid Front Deviation Length

134. 1310-axis find (rid Front Deviation Length

135. 1320-axis find (rid Front Deviation Length

Format 00000000 default value: 0, using "mm" as the unit

Scope: 0000.0000 0000.0000mm

If deviation frequently happens to the position before and after the HOM returning during the returning process and where the deviation length equals to the travel of one-round Servo Motor rotation, then such parameter can be adjusted to solve the aforesaid problem. In this case, the set value will be 0.5 of the travel of one-round Servo Motor rotation.

136. Arc Closed Angle Forward Offset (Pulse)

137. Arc Closed Angle Reverse Offset (Pulse)

138. Arc Closed Angle Offset Time (ms)

139. Arc Closed Angle Offset Function 00: Close; 01: Open

During the true roundness cutting process, the Motor used to present hysteresis phenomenon when making reverse action on the machine due to the mechanical factors. Such phenomenon used to happen to the round hole cutting for 02 or

3 or the 1, 1, 1 and 27 Closed Angle phenomenon on the cutting surface of the workpiece during round hole or cylindrical cutting for 2 or 3.

To offset the Closed Angle, the Controller will type out all the offset values instantly after changing the direction [within one offset cycle] and then compensate such offset value with straight-line acceleration/deceleration curve. The said offset level and time constant will be determined by the aforesaid three sets of parameters.

Forward Offset value: Execute the offset when the axis returns from the reverse action for moving towards the forward direction.

Reverse Offset value: Execute the offset when the axis returns from the forward action for moving towards the reverse direction.

Offset Time: The Controller will send out all of the offset values within the set offset time. When setting such parameter at zero, the system will compensate the said offset within one acceleration/deceleration cycle.

The Arc Closed Angle offset function [Close; 1: Open] is used to control the availability of the aforesaid parameters.

140. 2 Thread Tail Retreating Acceleration/Deceleration Time [ms]

Format [] [default value: 1]

When the thread reaches the end point under the command of 2, such parameter is used to set the acceleration/deceleration time when , are making fast thread tail retreating.

141. Whether or not to return to origin after -Stop

Format [] [default value:]

[] es, Returning to origin after -Stop is necessary for activating the process.

1: [] o. Returning to origin after -Stop is not necessary for activating the process.

142. If to stop the Spindle after ending the program

Format [] [default value:]

[] [] o

1: [] es

After activating the Spindle, if the working program does not execute the Spindle stop command before completing the program running, then such parameter can be used to stop the Spindle.

The customer can execute appropriate setting for such parameters according to the operation habitude.

143. If to start Auto Program

Format default value:

0

1: es

Such parameter is used to start the Semi-Auto/Auto function.

hen setting at “”, the system will close the Semi-Auto/Auto function.

hen setting at “1”, the system will open the Semi-Auto/Auto function.

Semi-Auto Function: The program will end the working when receiving M 2 or M3 .

Auto Function: The program will not end the working when receiving M 2 or M3 and will continue the loop to run the program.

144. ellow amp means Pause or Finish

Format default value:

ellow lamp means the Pause reminding signal.

1: ellow lamp means the Finish reminding signal.

2: ellow lamp means the Finish as well as the Pause reminding signal.

14 Spindle-specific RPM when starting

Format default value: 1

Such parameter is used to set the Spindle-specific RPM when starting the machine and when activating the Spindle manually or by M-Code before giving the S RPM command.

146. 1/ 2/ 3 for round-angle connection

Format default value: 2

Precision positioning without handling between 1/ 2/ 3 blocks

1: Round-angle connection between 2/ 3 blocks only

2: Round-angle connection between 1/ 2/ 3 blocks

User may set proper parameter values according to technical criteria of the substantial product.

147. If to disconnect the power when receiving the Servo Motor alarm

Format default value:

: o need to disconnect the power of Servo Motor.

1: eed to disconnect the power of Servo Motor.

hen the Servo Motor sends off an alarm, depending of varied requirements of the customer, the system can be set to disconnect the Main Circuit power of the Servo Motor and to retain the control power only. After removing the alarm, restore the Main Circuit power again.

If setting such parameter at “1” and when it is required to disconnect the Servo Motor power, then the O5 signal will be the “Servo Motor Control” O/OFF signal.

If O5 is under OFF status when the Servo Motor sends off alarm, it means the main power of such Servo Motor will be disconnected.

If O5 is under O status when the Servo Motor is working normally, it means the main power of such Servo Motor will not be disconnected.

Notice: If setting the parameter at “1”, then the 2-way Solenoid Valve cannot be selected for the Chuck of Spindle 1. If setting the parameter at “”, then the Spindle Chuck type can be set through the “Spindle Chuck 1-way/2-way Solenoid Valve” parameter.

Connections

Installation Configuration Descriptions

H6D-T Controller Wiring Schematics

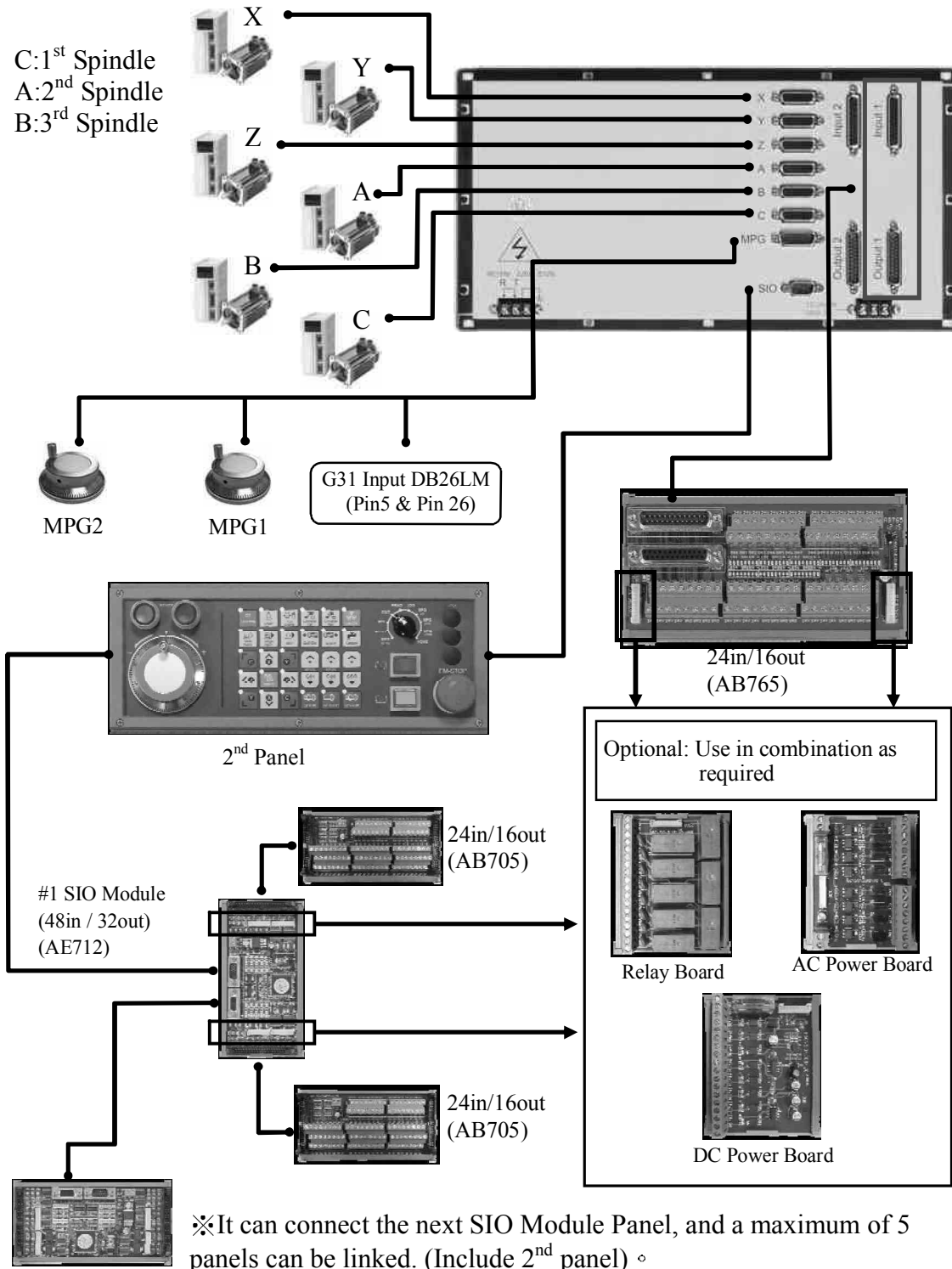

Fig.5-1

2 Ste installation

2.1 Operation environment

H6D-T Serial Controllers must be used in the following surroundings; anomaly may occur if the specified range is exceeded.

- * Temperature of surroundings
 - Operation — 0°C to 45°C.
 - Storage or transfer — -20°C to 55°C.
- * Rate of temperature variation — Max. 1.1°C/min
- * Relative Humidity
 - Normal — < 80% RH
 - Short period — Max. 95% RH
- * Vibration limits
 - In operation — 0.075 mm max. at 5 HZ
- * Noise
 - In operation — Max. voltage pulse in 0.01 S
2000 V/0.1×10⁻⁶ S
- * Other
 - Please consult our company for operations with a high amount of dust, cutting fluid or organic solvent.

2.2 Considerations for the design of Control panel

- * The controller and auxiliary panels shall be of a totally enclosed type to prevent dust ingress.
- * The internal temperature shall not exceed the surrounding temperature by more than 10°C.
- * Cable entries shall be sealed.
- * To prevent noise inference, a net clearance of 100mm shall be kept between the cables of each unit, AC power supply and CRT. If magnetic fields exist, a net clearance of 300mm shall be kept.
- * Refer to Server Operation Manual for the installation of servo driver.

2.3 Internal temperature design

The internal temperature shall not exceed the surrounding temperature by more than 10°C. The main considerations for designing the cabin are the heat source and the heat dissipation area. For the controller, the customer is usually unable to control the heat

source, however the heat dissipation area is a key factor to be considered. The internal temperature rise can be estimated using the following equations:

- (1) With a cooling fan, the permissible temperature rise shall be $1^{\circ}\text{C}/6\text{W}/1\text{m}^2$.
- (2) Without a cooling fan, the permissible temperature rise shall be $1^{\circ}\text{C}/4\text{W}/1\text{m}^2$.

The equations indicate that for a cabinet having a heat dissipation area of 1m^2 and a 6W heat source and a cooling fan (or 4W heat source without cooling fan), the internal temperature rise shall be 1°C . The heat dissipation area is the total surface area of the cabin minus the area in contact with the ground surface.

Ex.1: (with cooling fan)

heat dissipation area = 2 m^2

internal permissible temperature rise = 10°C

therefore the max. permissible heat source in the cabin is = $6\text{W} \times 2 \times 10 = 120\text{W}$.

If heat source within the cabin exceeds 120W, a cooling fin or other heat dissipation device must be provided.

Ex.2: (without cooling fan)

heat dissipation area = 2 m^2

internal permissible temperature rise = 10°C

therefore the max. permissible heat source in the cabin is = $4\text{W} \times 2 \times 10 = 80\text{W}$

If heat source within the cabin exceeds 80W, a cooling fin or other heat dissipation device must be provided.

H6D-T Internal Dimensions

H6D-T Controller

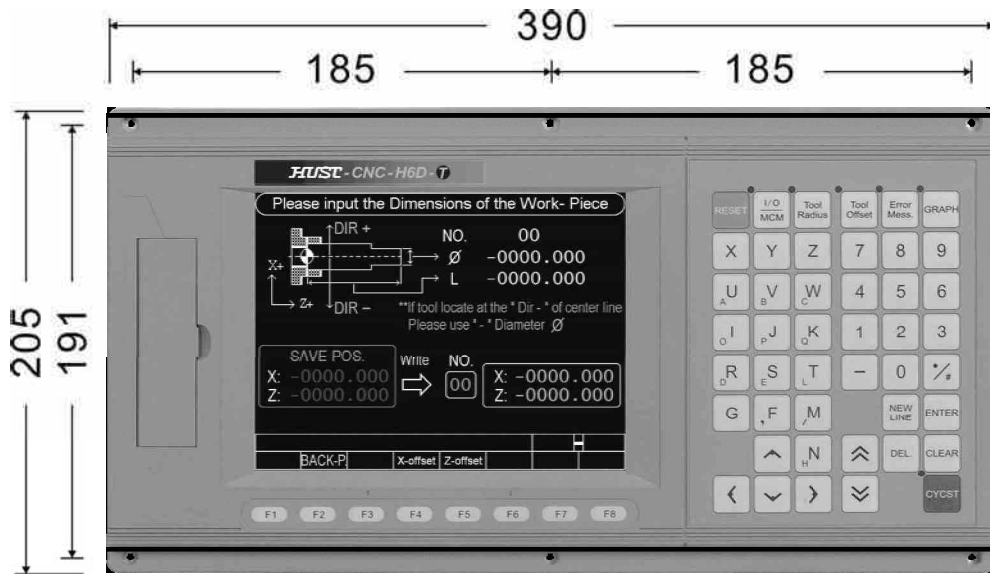

Fig.5-2 Panel Dimensions

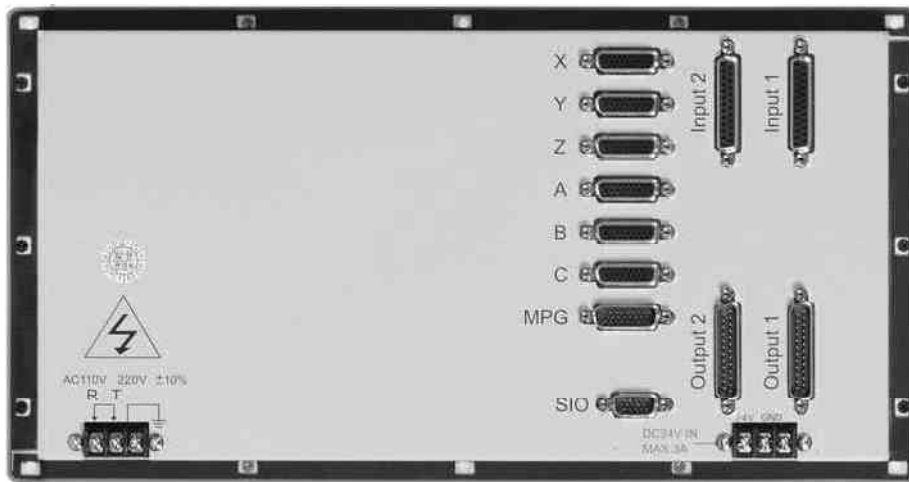

Fig.5-3 Case Dimensions (Rear view)

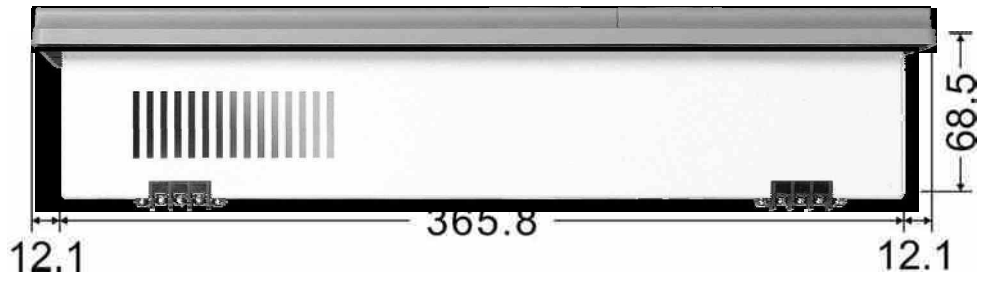

Fig.5-4 Case Dimensions (TOP view)

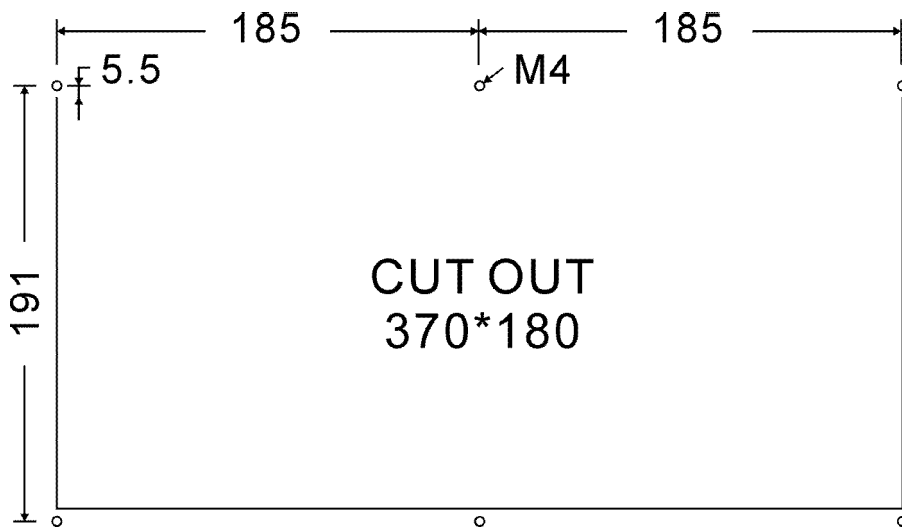

Fig.5-5 Cutout Dimensions

H6DL-T Controller

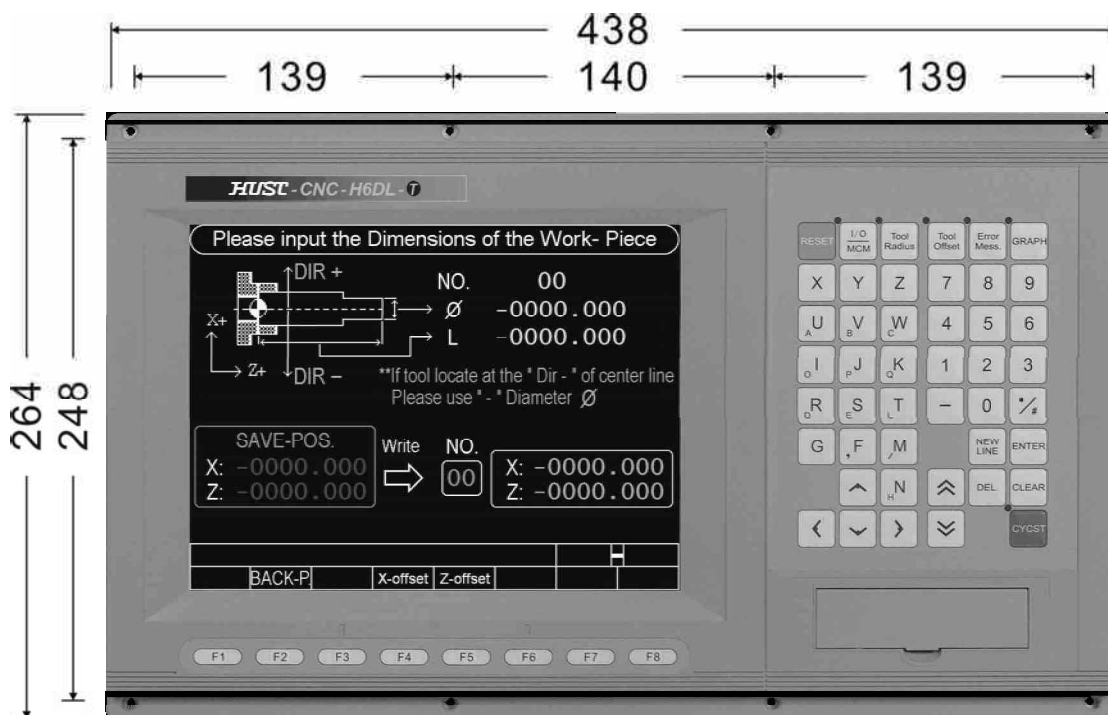

Fig.5-6 Panel Dimensions

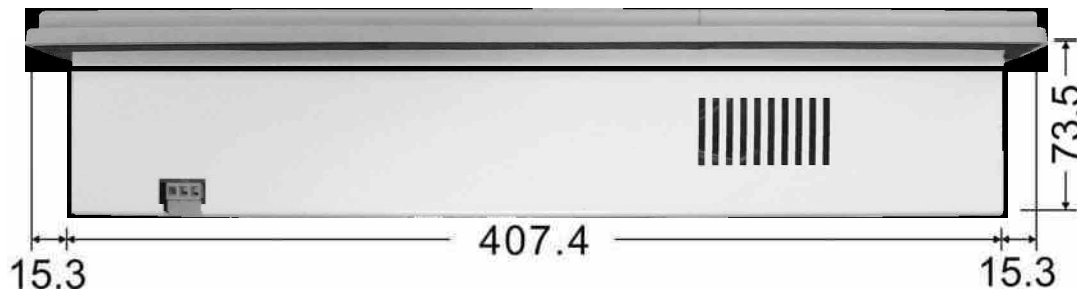

Fig.5-7 Case Dimensions (TOP view)

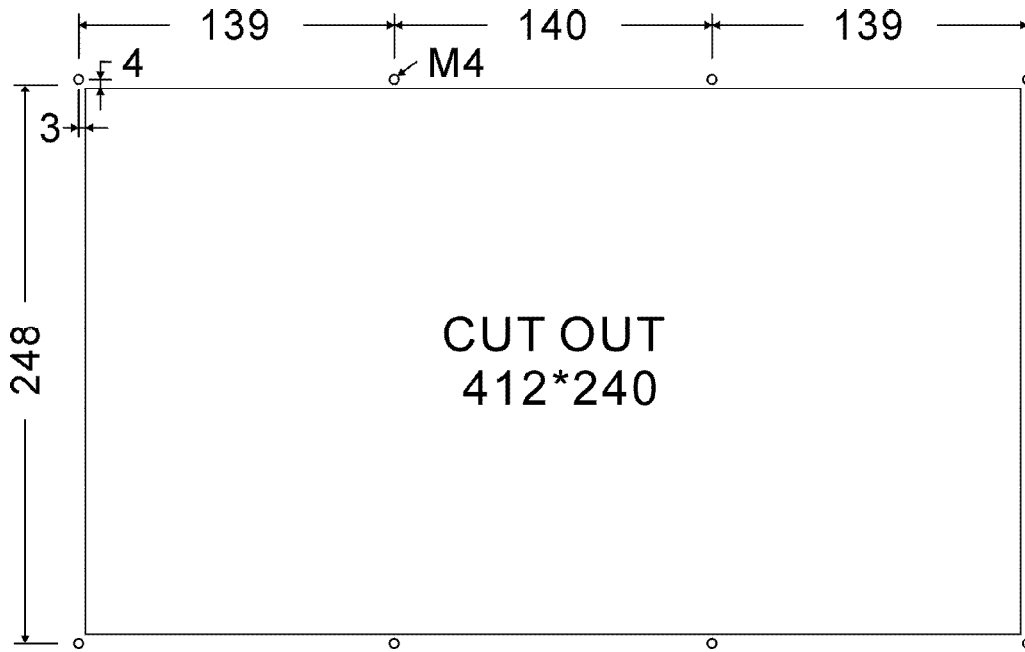

Fig.5-8 Cutout Dimensions

H6D-T Auxiliary Panel

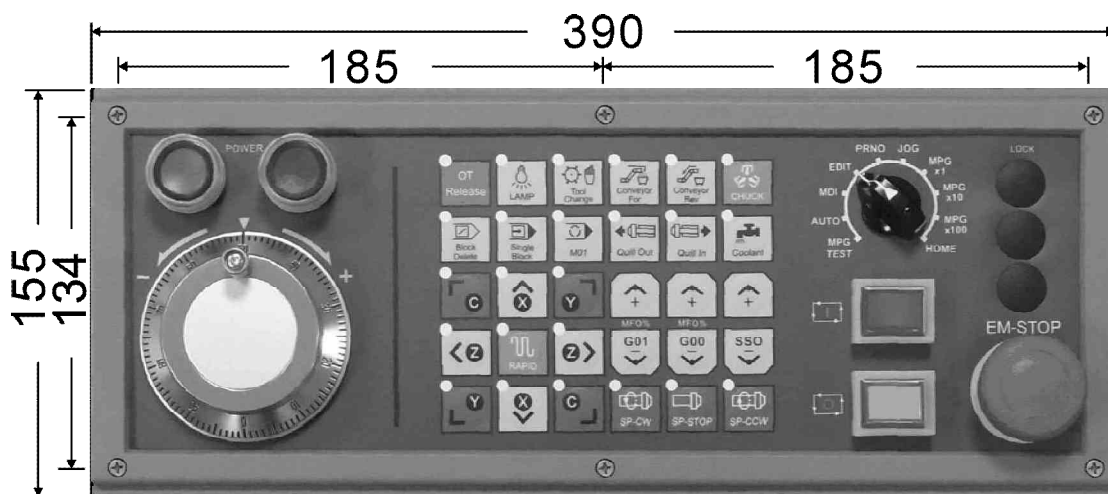

Fig.5-9 Auxiliary panel Dimensions

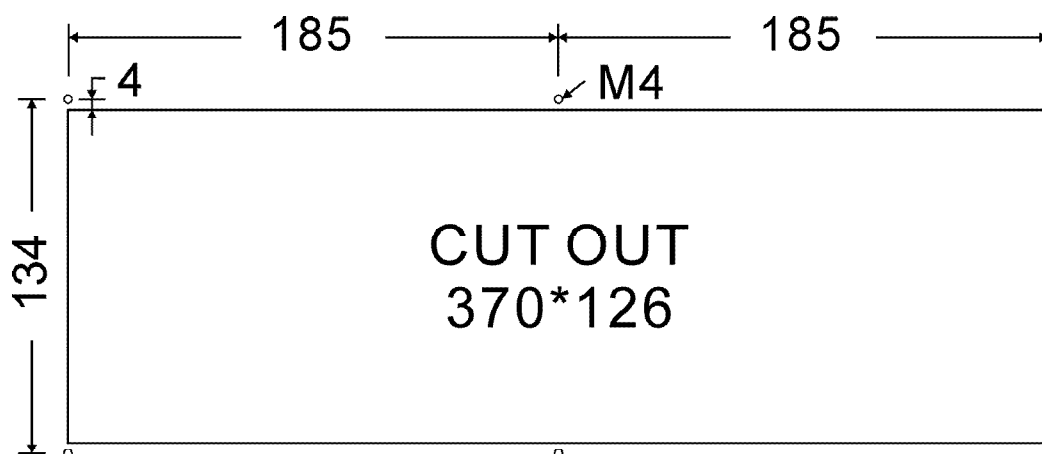

Fig.5-10 Cutout Dimensions

H6DL-T Auxiliary Panel

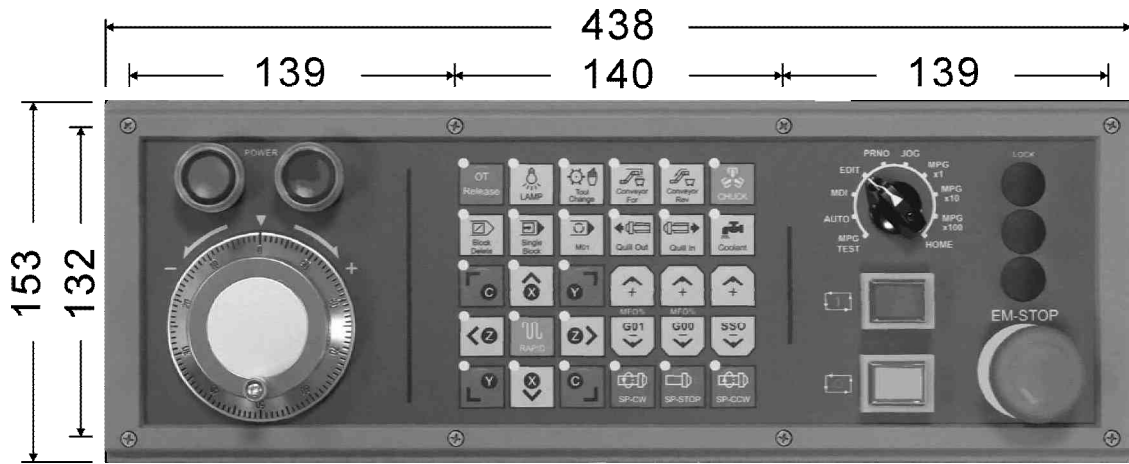

Fig.5-11 Auxiliary panel Dimensions

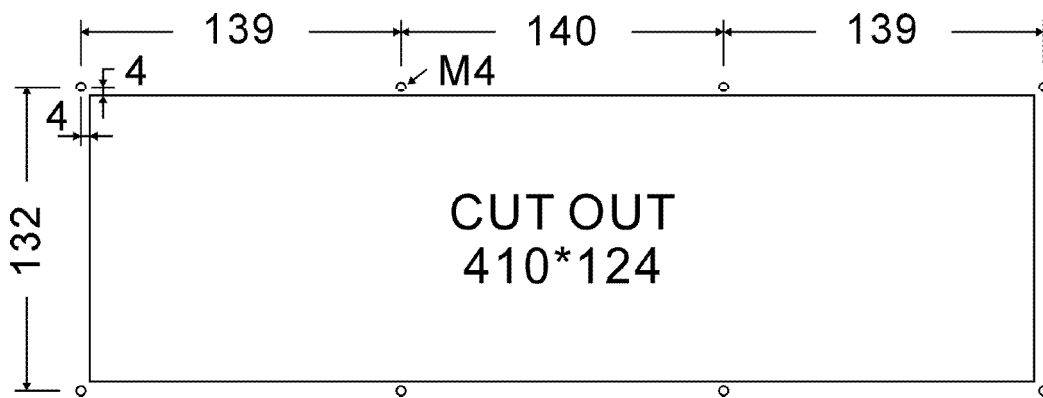

Fig.5-12 Cutout Dimensions

□□□□ H6D-T □□□□ Accessories Dimensions

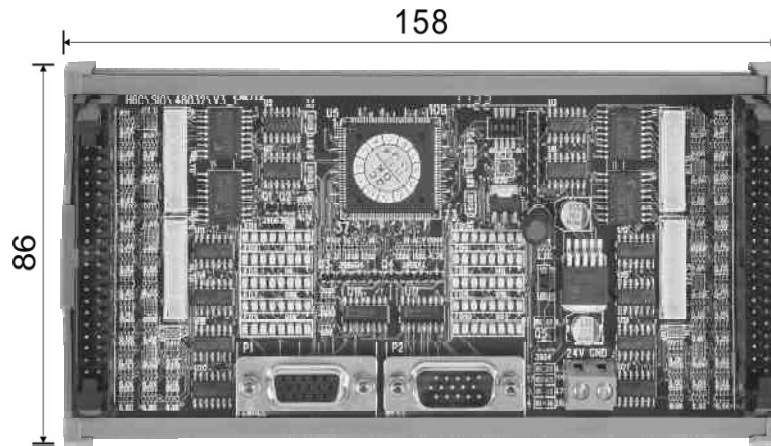

Fig.5-13 SIO Module : 48IN/32OUT

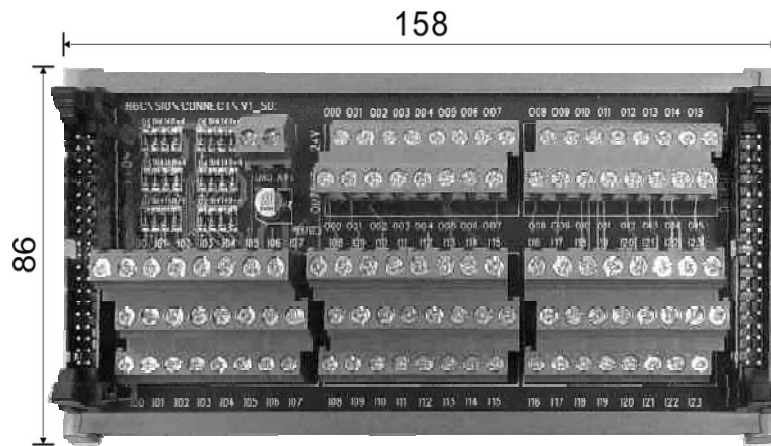

Fig.5-14 IO connect board : 24IN/16OUT

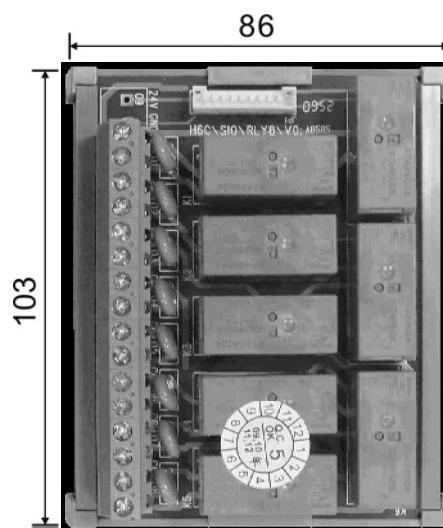

Fig.5-15 NPN Output relay board : 8 Out

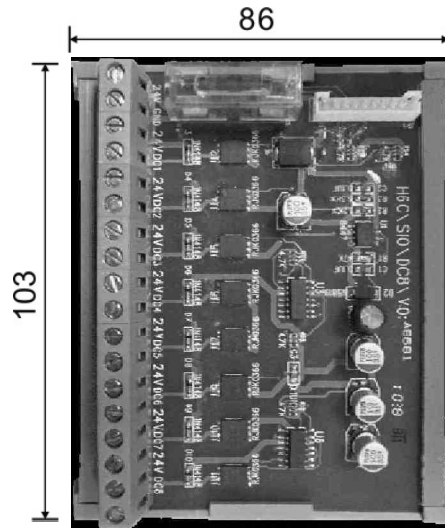

Fig.5-16 DC Power module board : 8 Out

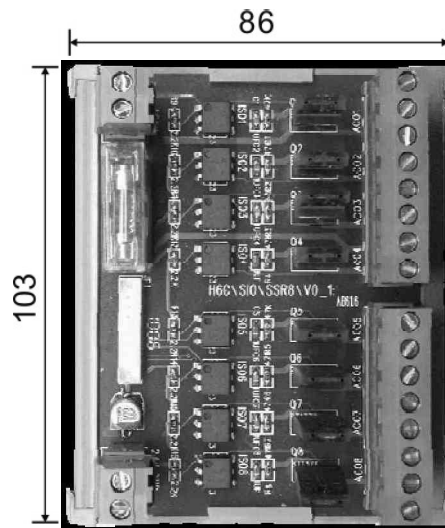

Fig.5-17 AC Power output module board : 8 Out

Connector Type

HUST H6D Series Controller rear panel connectors:

- DBxx : xx indicates number of pins
- DB9L : 9-pin connector
- DB9LF : a terminal with a female 9-pin connector
- DB15LM: a terminal with a male 15-pin connector

Connector name

Connector types of the controller are as follows:

Table 5-1 Connector Designation and Type

| Connector Name | Connector Designation | Type |
|-------------------------|-----------------------|------------|
| X-axis servo | X-AXIS | DB26LF (F) |
| Y-axis servo | Y-AXIS | DB26LF (F) |
| Z-axis servo | Z-AXIS | DB26LF (F) |
| A-axis servo | A-AXIS | DB26LF (F) |
| B-axis servo | B-AXIS | DB26LF (F) |
| C-axis servo | C-AXIS | DB26LF (F) |
| MPG Handwheel | MPG | DB26LM (M) |
| Standard INPUT-1 | INPUT-1 | DB25LF (F) |
| Standard OUTPUT-1 | OUTPUT-1 | DB25LF (M) |
| Standard INPUT-2 | INPUT-2 | DB25LF (F) |
| Standard OUTPUT-2 | OUTPUT-2 | DB25LF (M) |
| Communication Interface | RS232 | DB9LF (F) |
| | USB | USB (F) |

6 Connector Pin-out Definition

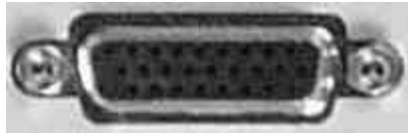

DB26LF (F)

Table 5-2 HUST H6D Axis Connector Pin

| Pin No | Definition | Description |
|--------|------------|--|
| 1 | /A | /A phase input |
| 2 | A | A phase input |
| 3 | B | B phase input |
| 4 | /B | /B phase input |
| 5 | Z | Z phase input |
| 6 | /Z | /Z phase input |
| 7 | VCMD | 0~10V analog command |
| 8 | GND | 5V GND (V-command、Torgue & +5V GND) |
| 9 | 5V | +5V Power |
| 10 | TOG | Torgue input |
| 11 | - | - |
| 12 | - | - |
| 13 | - | - |
| 14 | - | - |
| 15 | - | - |
| 16 | - | - |
| 17 | IN-49 | Group 2 Input signal ※Note |
| 18 | OUT-49 | Group 2 Output signal ※Note |
| 19 | Pulse+ | |
| 20 | Pulse- | |
| 21 | Sign+ | Pulse Direction+ |
| 22 | Sign- | Pulse Direction - |
| 23 | IN-48 | Group 1 Input signal ※Note |
| 24 | OUT-48 | Group 1 Output signal ※Note |
| 25 | 24V | +24V Power |
| 26 | 24VGND | 24V GND I/O & +24V GND |

※ Note: Z axis group 1 I/O address at IN-52(pin23) OUT-52(pin24)
Z axis group 2 I/O address at IN-53(pin17) OUT-53(pin18)

※ Output current at O: 30mA (H6D\CPU\V6_1 : 50mA)

* M□□ H6D□

H6D & H9D that Pin10、Pin11 different only, Please reference the Table 3-3、Table 3-4.



DB26LM (M)

Table 5-3 H6D <MPG> Definition

| PinNo | Definition | Description | MPG1 | MPG2 | DA1 | DA2 | AD1 | AD2 | G31 |
|-------|------------|--|------|------|-----|-----|-----|-----|-----|
| 1 | A1 | A phase output (MPG1) | ● | | | | | | |
| 2 | B1 | B phase output (MPG1) | ● | | | | | | |
| 3 | A2 | A phase output (MPG2) | | ● | | | | | |
| 4 | B2 | B phase output (MPG2) | | ● | | | | | |
| 5 | G31 IN | Inputs signal to control high-speed axial stop | | | | | | | ● |
| 6 | GND | 5V GND | | | | | | | |
| 7 | | MPG、AD/DA & +5V | ● | ● | ● | ● | ● | ● | |
| 8 | | GND | | | | | | | |
| 9 | 5V | +5V Power | ● | ● | | | | | |
| 10 | IN-86 | Group 18 input signal | | | | | | | |
| 11 | IN-87 | Group 19 input signal | | | | | | | |
| 12 | DA1 | 0~10V analog command 1 | | | ● | | | | |
| 13 | DA2 | 0~10V analog command 2 | | | | ● | | | |
| 14 | AD1 | ±10V analog command Input 1 | | | | | ● | | |
| 15 | AD2 | ±10V analog command Input 2 | | | | | | ● | |
| 16 | | | | | | | | | |
| 17 | D+ | CANOpen Signal | | | | | | | |
| 18 | D- | CANOpen Signal | | | | | | | |
| 19 | IN-80 | Group 12 input signal | | | | | | | |
| 20 | IN-81 | Group 13 input signal | | | | | | | |
| 21 | IN-82 | Group 14 input signal | | | | | | | |
| 22 | IN-82 | Group 15 input signal | | | | | | | |
| 23 | IN-84 | Group 16 input signal | | | | | | | |
| 24 | IN-85 | Group 17 input signal | | | | | | | |
| 25 | 24V | +24V Power | | | | | | | |
| 26 | 24VGND | 24V GND I/O、G31、+24VGND | | | | | | | ● |

* M□□ H□D□

H6D & H9D that Pin10・Pin11 different only, Please reference the Table 3-3・Table 3-4.



DB26LM (M)

Table 5-4 H9D <MPG> Definition

| PinNo | Definition | Description | MPG1 | MPG2 | DA1 | DA2 | AD1 | AD2 | G31 |
|-------|------------|--|------|------|-----|-----|-----|-----|-----|
| 1 | A1 | A phase output (MPG1) | ● | | | | | | |
| 2 | B1 | B phase output (MPG1) | ● | | | | | | |
| 3 | A2 | A phase output (MPG2) | | ● | | | | | |
| 4 | B2 | B phase output (MPG2) | | ● | | | | | |
| 5 | G31 IN | Inputs signal to control high-speed axial stop | | | | | | | ● |
| 6 | GND | 5V GND | | | | | | | |
| 7 | | MPG・AD/DA & +5V | ● | ● | ● | ● | ● | ● | |
| 8 | | GND | | | | | | | |
| 9 | 5V | +5V Power | ● | ● | | | | | |
| 10 | +12V | +12V Power | | | | | | | |
| 11 | -12V | -12V Powe | | | | | | | |
| 12 | DA1 | 0~10V analog command 1 | | | ● | | | | |
| 13 | DA2 | 0~10V analog command 2 | | | | ● | | | |
| 14 | AD1 | ±10V analog command Input 1 | | | | | ● | | |
| 15 | AD2 | ±10V analog command Input 2 | | | | | | ● | |
| 16 | | | | | | | | | |
| 17 | D+ | CANOpen Signal | | | | | | | |
| 18 | D- | CANOpen Signal | | | | | | | |
| 19 | IN-80 | Group 12 input signal | | | | | | | |
| 20 | IN-81 | Group 13 input signal | | | | | | | |
| 21 | IN-82 | Group 14 input signal | | | | | | | |
| 22 | IN-82 | Group 15 input signal | | | | | | | |
| 23 | IN-84 | Group 16 input signal | | | | | | | |
| 24 | IN-85 | Group 17 input signal | | | | | | | |
| 25 | 24V | +24V Power | | | | | | | |
| 26 | 24VGND | 24V GND I/O・G31・+24VGND | | | | | | | ● |

* □DD□ □nalo□□i□nal □irin□

Table 5-5

| Register | Function | Description |
|----------|--|---------------------------|
| R209 | Analog Input & Torque function enable | Edit by PLC <R209 bit3=1> |
| R142 | AD1, Indicates value of #1 analog voltage input | Pin 14 ∙ Pin 8 |
| R143 | AD2, Indicates value of #2 analog voltage input | Pin 15 ∙ Pin 8 |
| R146 | AD1, Indicates value of #1 analog voltage output | Pin 12 ∙ Pin 8 |
| R147 | AD2, Indicates value of #2 analog voltage output | Pin 13 ∙ Pin 8 |

※ Note : R209 bit3=1 that analog Input function must enable.

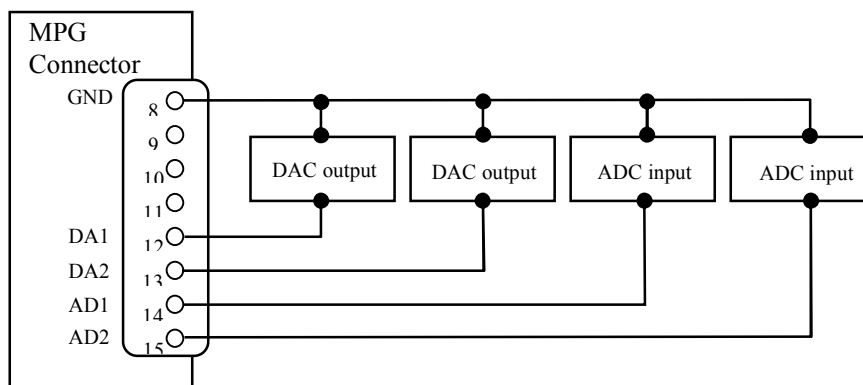

Fig 5-18 AD/DA Analog Signal Wiring

61 1 N T Control signals

Contol High-Speed axial stop, responding in 0.5 μ sec.

Table 5-6

| Settings for related Parameters and Registers | Description |
|---|---|
| R250 | Setting = 0, I-bit Input signal is an ascending (0→1) trigger signal |
| | Setting = 1, I-bit Input signal is a descending (1→0) trigger signal |
| | Setting = 2, I-bit Input signal is a Normal Open (0) signal |
| | Setting = 3, I-bit Input signal is a Normal Close (1) signal |

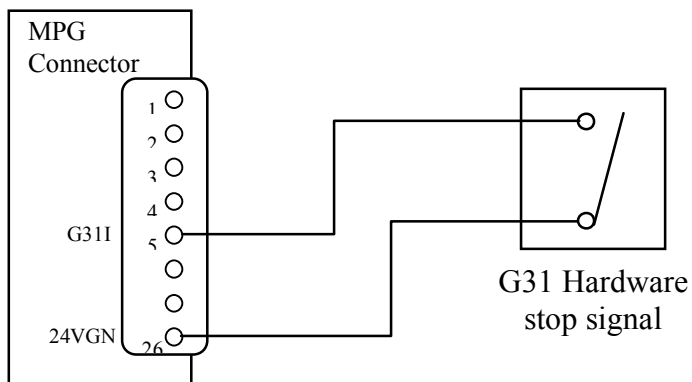

Fig 5-19 G31 INPUT Signal Wiring

62 **axial Control pin assignment and wiring**

Connect servo driver to axial-control connector as shown in Fig.5-20 (pin assignment identical for all axes).

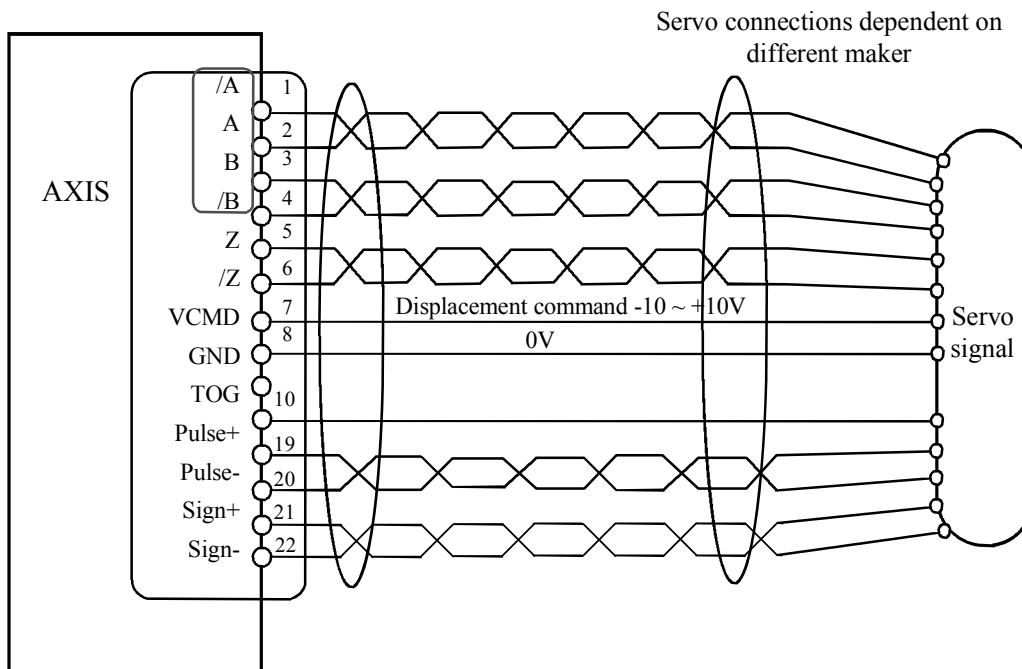

Fig.5-20 Wiring for Axial Control

1. Isolated twist-pair cables shall be used.
2. Pay special attention to Pins 1-4 of the axial connection. In case the motor runs scattering, alter the terminal A with the terminal B at the driver end.
3. HUST miller controller, when voltage-command type servo motor is used, you need to set the Follow Error checking function. (Not applicable to pulse commands.)
 - (a) Parameter 533 = 4096 → check the value of Follow Error.
 - (b) Parameter 543 = 63 → check Follow Error of the axis X/Y/Z/A/B/C simultaneously (set by BIT: Bit0=1 for X-axis, Bit1=1 for Y-axis.....).
 - (c) When the ERROR COUNT of the actual feedback of X-axis motor >4096, the system will issue an error message.
4. In H6D-T Controller, connect Spindle 1 to C-axis, Spindle 2 to A-axis and Spindle 3 to B-axis; and other axes will be connected according to the wiring method shown.

6.2.2 Spindle Control

There are 2 types of Spindle Control:

- (a) Voltage Command type
- (b) Pulse Command type

6.2.2.1 Voltage Command type

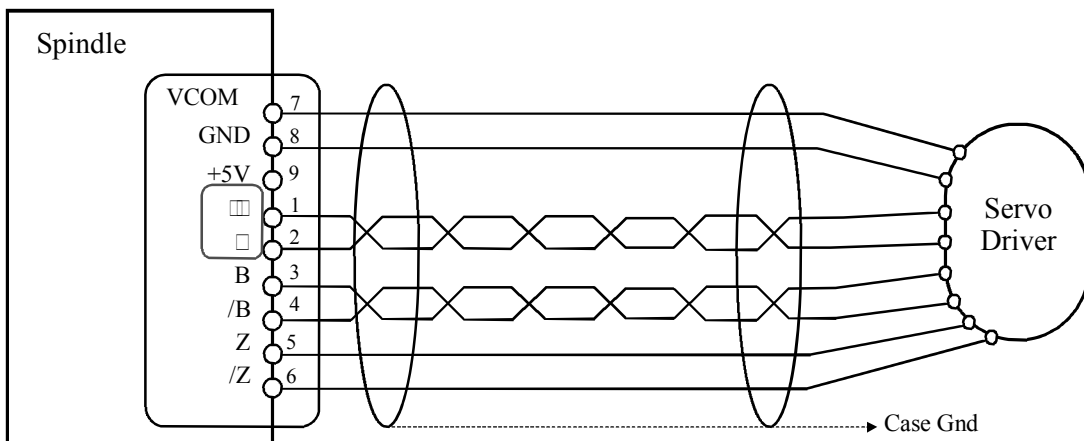

Fig.5-22 Spindle voltage command control-closed circuit wiring (servo)

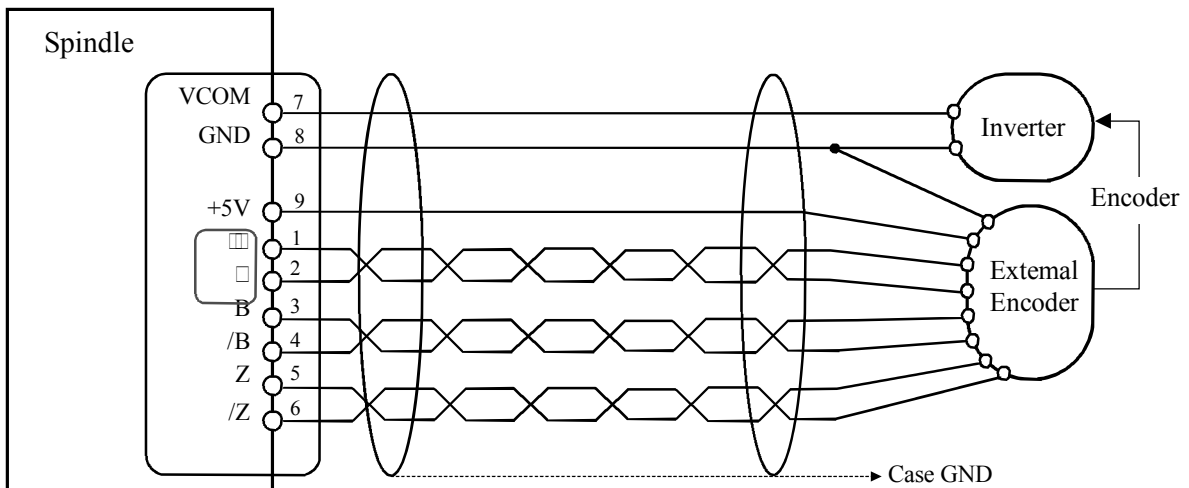

Fig.5-23 Spindle Voltage Command Control- Open circuit wiring (Inverter)

□ Pulse Command and Type

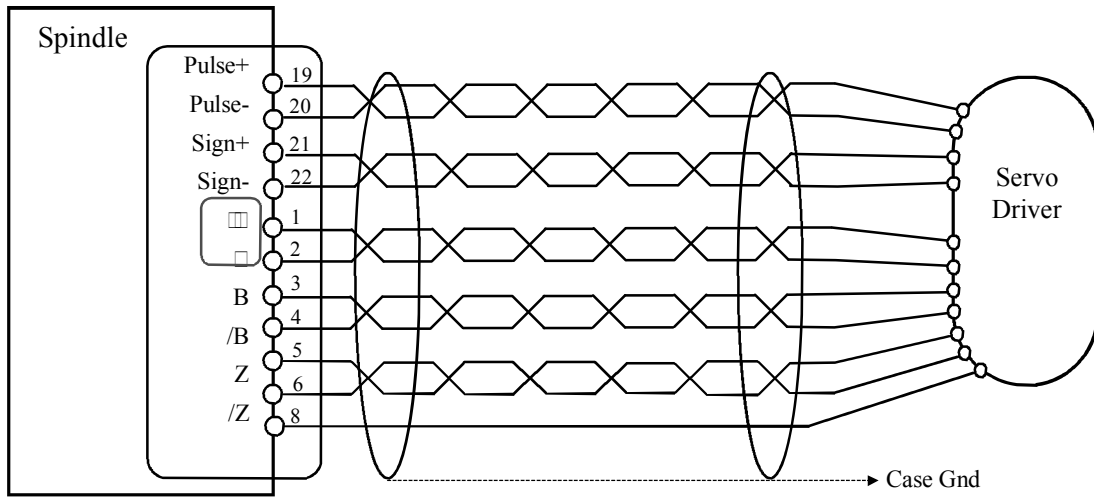

Fig.5-24 Spindle pulse command control- closed circuit wiring (servo)

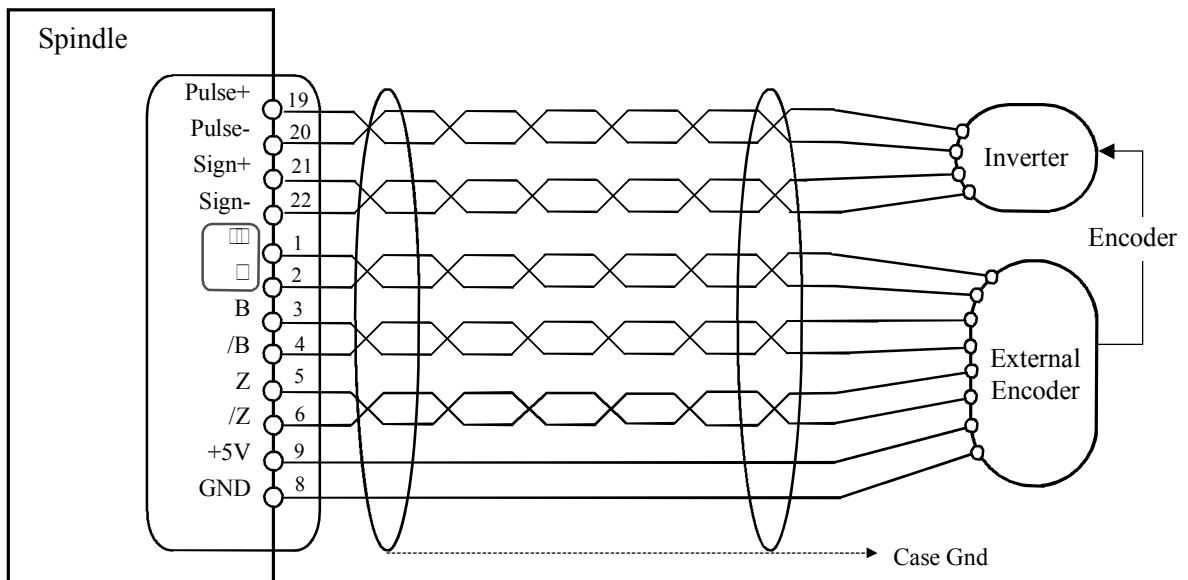

Fig.5-25 Spindle pulse command control- closed circuit wiring (Inverter)

6 0 irin

* Structure of irin 1

All of the SIO board must used the same 【DC24V power supply】 except to the AC output board.

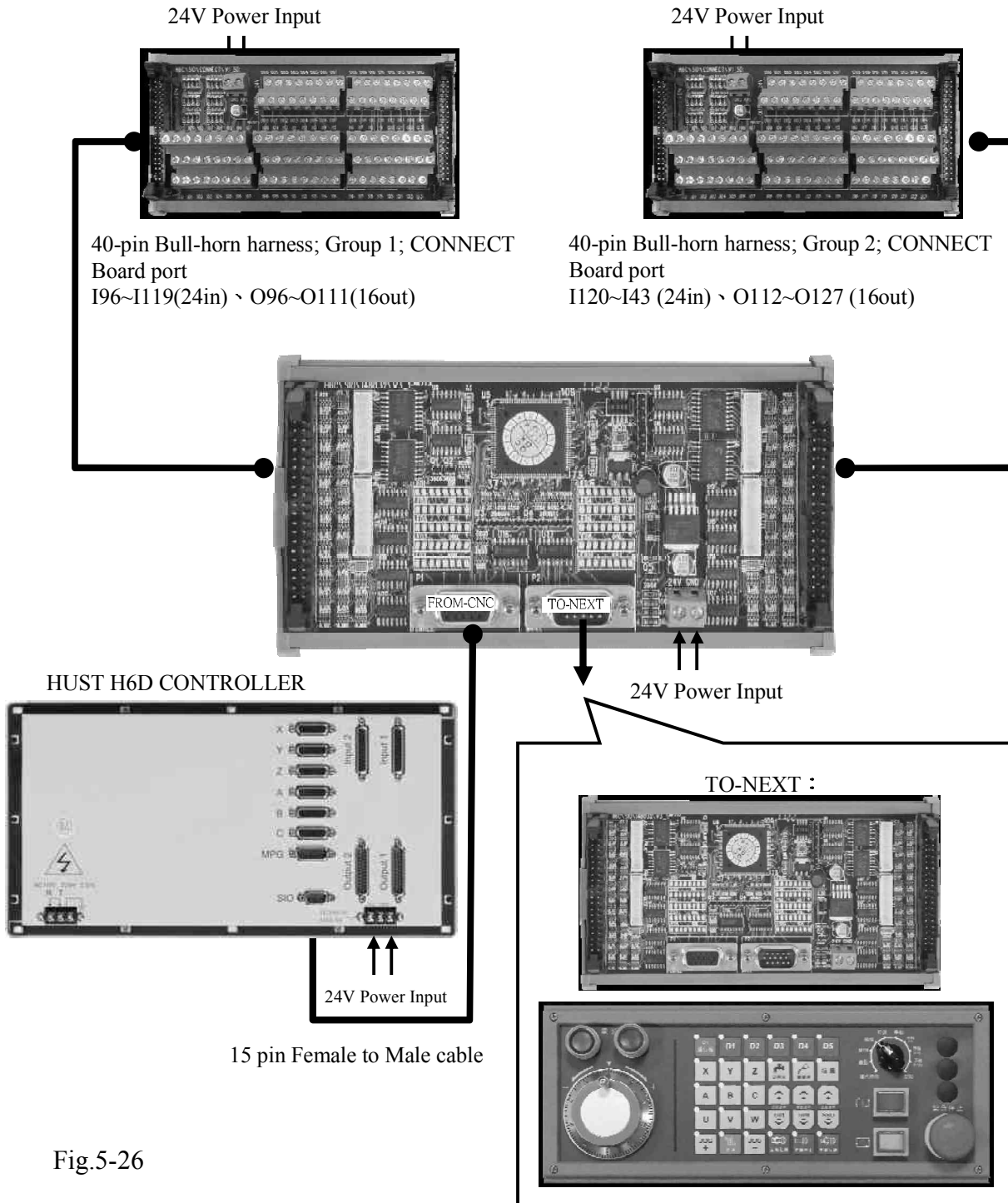
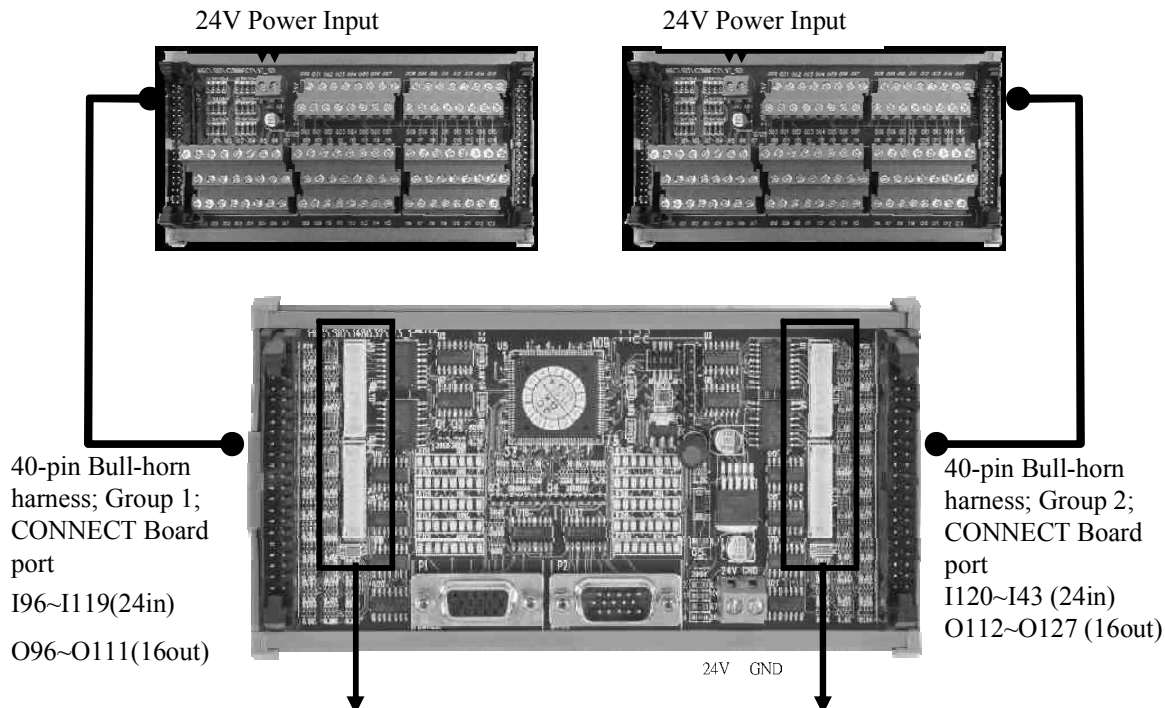
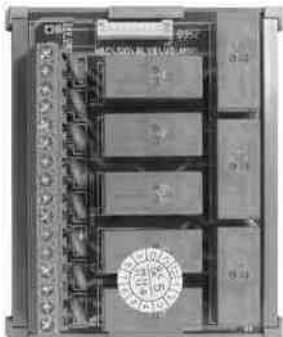

Fig.5-26

* Structure of IIRIN 2

All of the SIO board must used the same 【DC24V power supply】 except to the AC output board.



1. Use in combination as required
 2. 10 pin white connecto
 3. Can be connected to 3 optional boards
 4. Can be connect 4 modules maximum .
 5. NPN RELAY BOARD : provide 8 dry contacts. Max. current for each output of the PCB is 1A .
 6. AC power output module board : provide 8 AC110V outputs. Max. current for each output of the PCB is 1A.
 7. DC power module board : provide 8 DC24V outputs. Max. current for each output of the PCB is 1A .
- Accessories :
- 

8 OUT RELAY BOARD

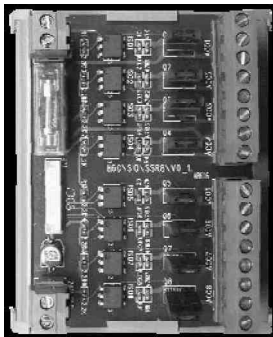

AC POWER OUTPUT
MODULE BOARD

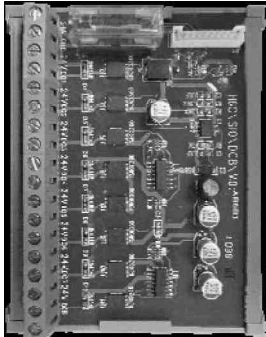

DC POWER OUTPUT
MODULE BOARD

Fig.5-27

5.6 Input/Output Characteristics

The input signals are the messages transmitted to the Controller from the external device. These signals can be generated by push button, Limit Switch, Relay Board connection or Proximity Switch, etc.

The output signals are the messages transmitted to external working machine from the Controller, which are used to drive the Relay of the Working Machine and the LED display of the Controller.

Input/Output Interface

The Controller must link with other accessories through SIO Module Board so as to control the actions of external I/O, power output and axis control module.

* I/O Connect Board (C Board No.: H6D-IO-06)

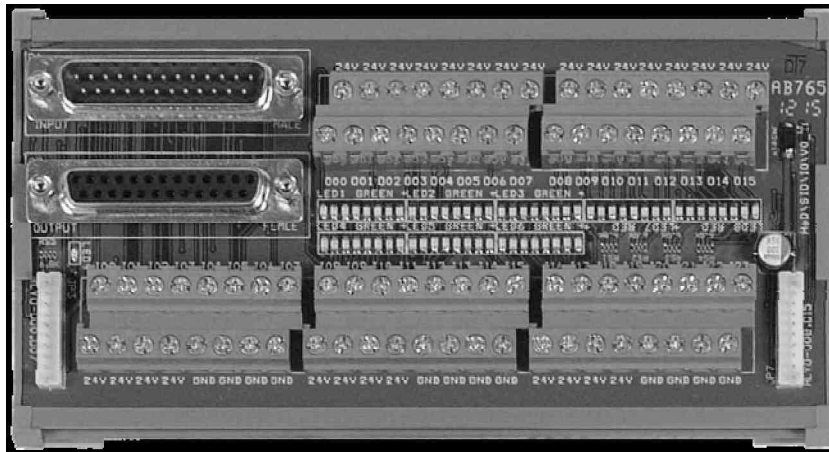

Fig 5-28

1. I/O connect board controls 24 input terminals and 16 output terminals.
2. Output control is by 0V output.
3. An INPUT can be of NPN type or PNP type.
4. When NPN and PNP are in use at the same time,
 - (1) NPN : the input voltage at I is 0V.
 - (2) PNP : the input voltage at I is 24V.
5. Input current at I: 3.6mA
6. Output current at O: 100mA (H6D\CPU\V6_1 : 250mA).

Input Pin Assignment (Female)

Output Pin Assignment (Male)

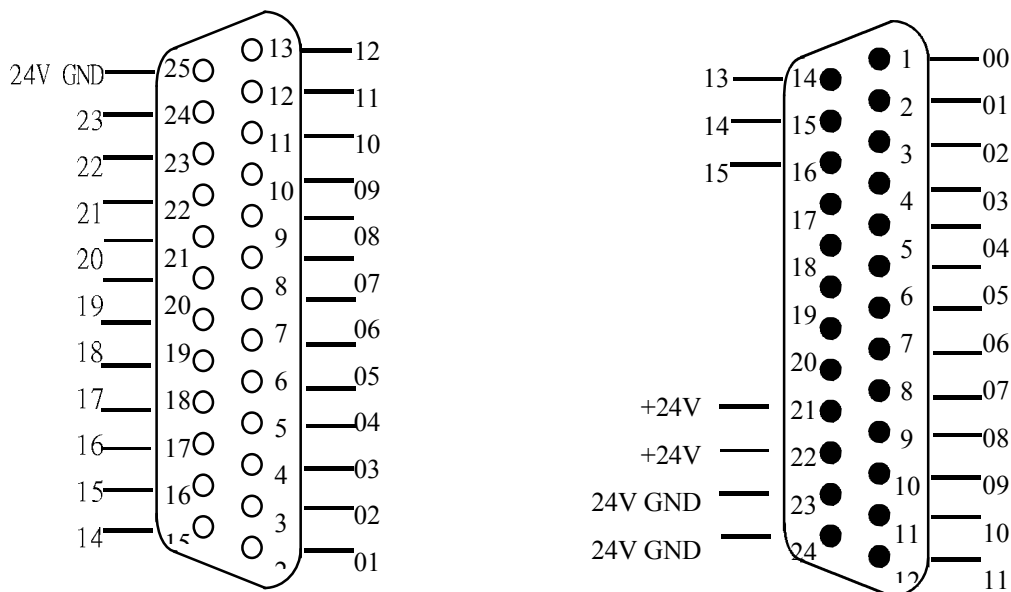

Table 5-29 I/O Connector Pin Assignment (NPN-PNP Type)

* **Serial Input/Output Module Board (H6C10020112)**

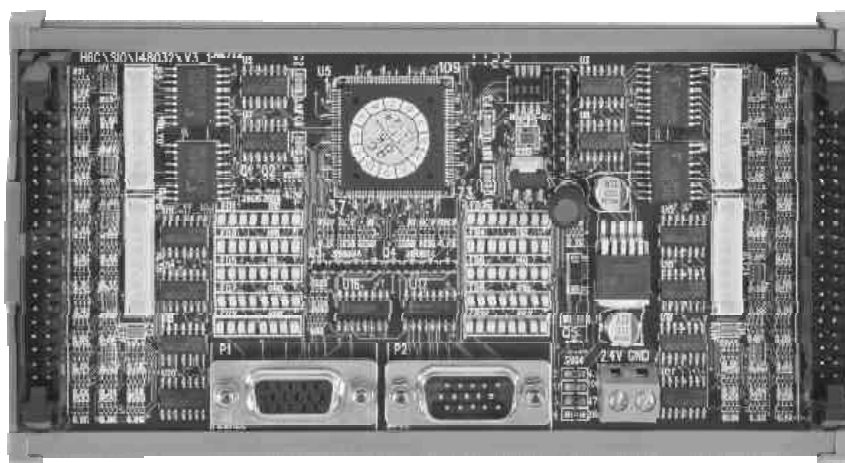

Fig.5-30

Serial Input/Output Module

1. The SIO Module Board is provided with 48 input/32 output points respectively.
 - (a) A maximum of 4 boards can be linked in providing maximum 256 input/176 output points respectively.
 - (b) It can be linked with Auxiliary Panel (Panel 2).
2. The module can work with the following external components:
 - (a) Standard input/output CONNECT panel (24 Input/16 Output).
 - (b) 8 Out Relay boards.
 - (c) 8 Out DC power boards.

- (d) 8 Out AC power boards.
- (e) 8 Out Axis Control Modules: To control the Servo or Step Motor.
- 3. When using with Universal Auxiliary Panel, it will occupy the I/O position of Panel 2.
- 4. The Dip Switch is used to define the I/O starting position of SIO Module Board.

Explanation of I/O MODULE BOARD :

LED-lamp (Input) : ❶

LED-lamp (Output) : ❷

SWITCH : ❸

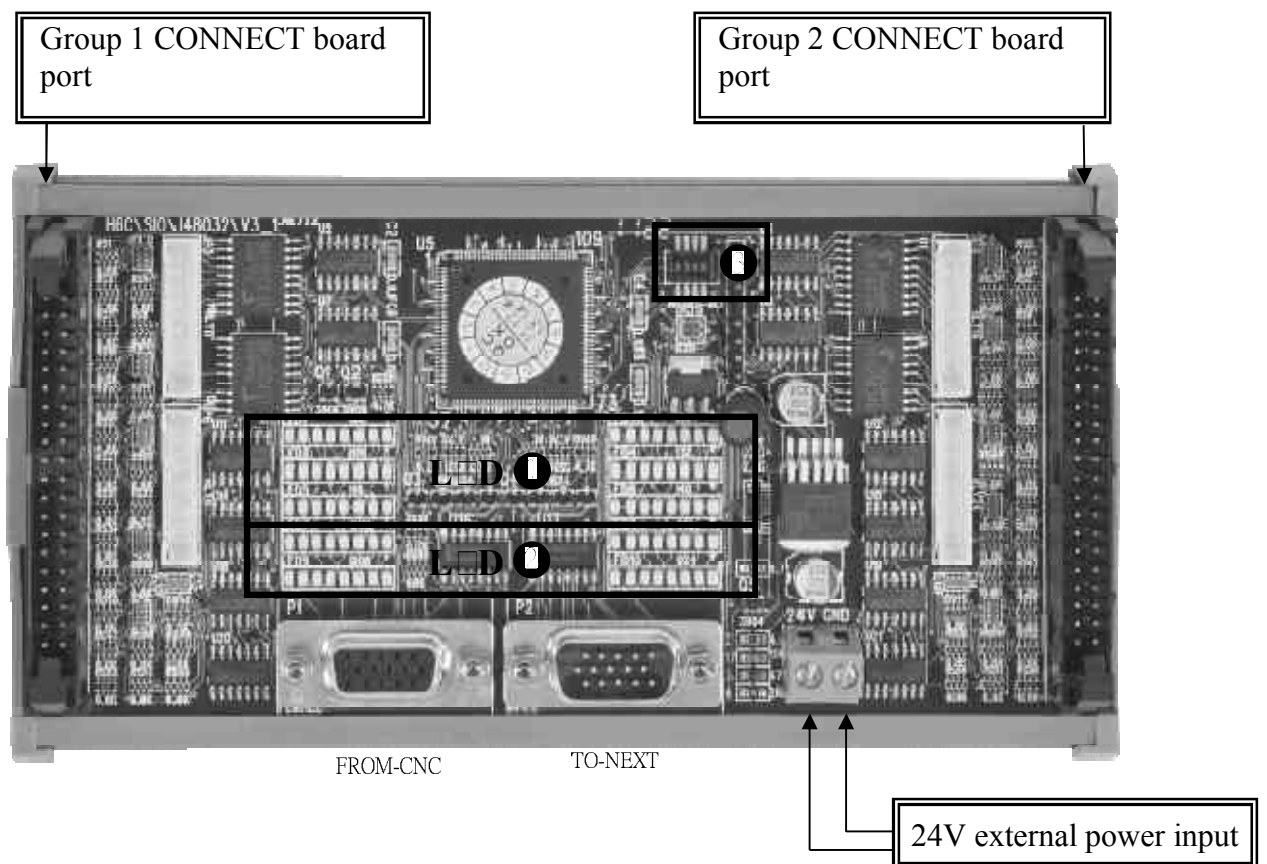

Fig.5-31

1. LED Indicator:
 - I-Point Signal LED Indicator (Green) ❶: 3 groups each for upper and lower rows with each group containing 8 lamps, which makes a total of 48 lamps.
 - O-Point Signal LED Indicator (Red) ❷: 2 groups each for upper and lower rows with each group containing 8 lamps, which makes a total of 32 lamps.
2. Dip Switch ❸: For setting the SIO Module Board and I/O starting signal position.

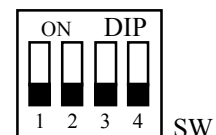

Table 5-7 Dip Switch – I/O Module Corresponding Positions

| MODULE | Switch 1 | Switch 2 | Switch 3 | Switch 4 | IN range | OUT range |
|-----------------|----------|----------|----------|----------|-------------|-------------|
| 1 st | 0 | 0 | 0 | 0 | I096 ~ I143 | O096 ~ O127 |
| 2 nd | 1 | 1 | 0 | 0 | I144 ~ I191 | O144 ~ O175 |
| 3 rd | 0 | 1 | 1 | 0 | I192 ~ I239 | O192 ~ O223 |
| 4 th | 1 | 0 | 0 | 1 | I240 ~ I255 | O240 ~ O255 |

※ **Module board can control 16 unit of inputs and 16 units of Outputs**

IO related scope when using with Operation Panel 2

Table 5-8 H6D / H9D Controller I/O Corresponding Scope

| IO range | | | | | | |
|-----------------|---|----------|----------|----------|-------------|--------------|
| Board | Switch 1 | Switch 2 | Switch 3 | Switch 4 | Input range | Output Range |
| 1 st | 0 | 0 | 0 | 0 | I096 ~ I143 | O096 ~ O127 |
| 2 nd | General Purpose Secondary Control Panel | | | | I144 ~ I191 | O144 ~ O175 |
| 3 rd | 0 | 1 | 1 | 0 | I192 ~ I239 | O192 ~ O223 |
| 4 th | 1 | 0 | 0 | 1 | I240 ~ I255 | O240 ~ O255 |

※ When use 2nd control panel, 2nd SIO address Occupancy.

*** Connect board H6C-O-CONNECT-1-D**

1. I/O connect board controls 24 input terminals and 16 output terminals.
2. Output control is by 0V output.
3. An INPUT can be of NPN type or PNP type.
4. When NPN and PNP are in use at the same time,
 - (1) NPN : the input voltage at I is 0V.
 - (2) PNP : the input voltage at I is 24V.
5. Input current at I: 6mA
6. Output current at O: 100mA

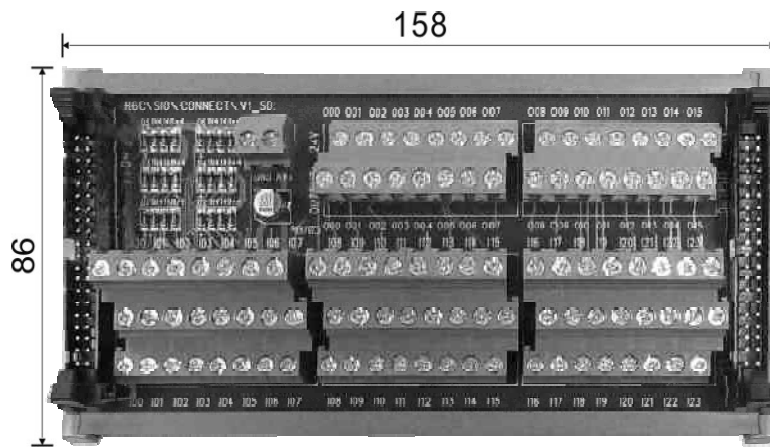

Fig.5-32

*** Output relay board H6C-O-L**

1. Max. current for each output of the PCB is 1A
 2. For a max. current > 1A, use other relays.
- Contacts on the RELAY adaptor board are dry contacts

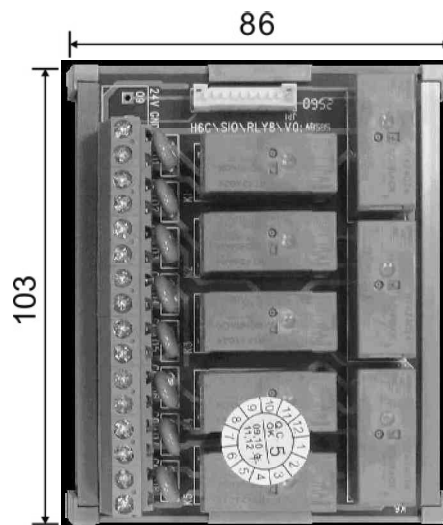

Fig.5-33

* AC power output module board H6C1010000000000616

1. AC Power supply adaptor board controls 8 AC110 outputs.
2. Max. current for each output of the PCB is 1A .
3. The 8 Output terminals can sustain a max. current of 8A, all together.
4. 24V power supply can be used alone.
5. Rating of the factory supplied fuse is 5A.

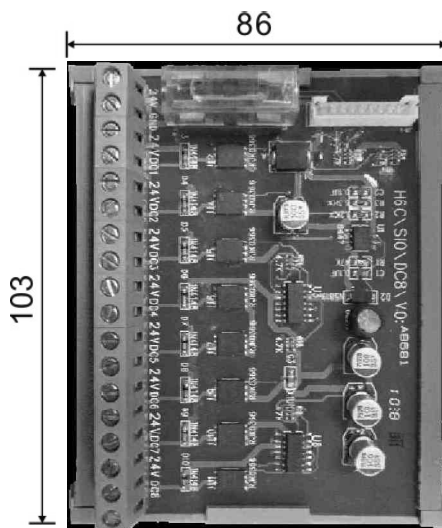

Fig.5-34

* DC power module board H6C1010DC0000006000

1. DC power output board controls 8 sets of DC 24V output.
2. Max. current for each output of the PCB is 1A .
3. The 8 Output terminals can sustain a max. current of 8A, all together.
4. Rating of the factory supplied fuse is 5A

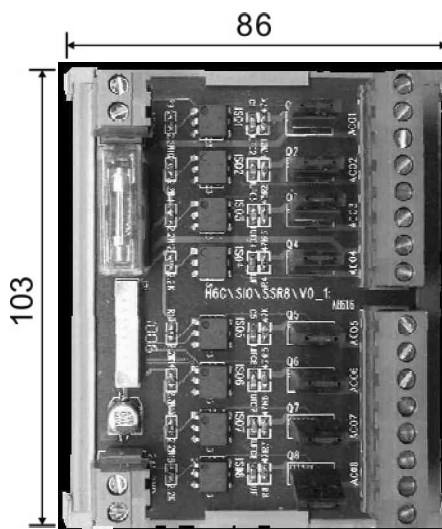

Fig.5-35

6 Error on origin examples

* Error on top origin diagram-1

Recommended wiring diagram. In this connection, the software control and hardware control are connected in a series; when the E-stop button is pressed, the hardware will switch off Servo-On even if the software fails.

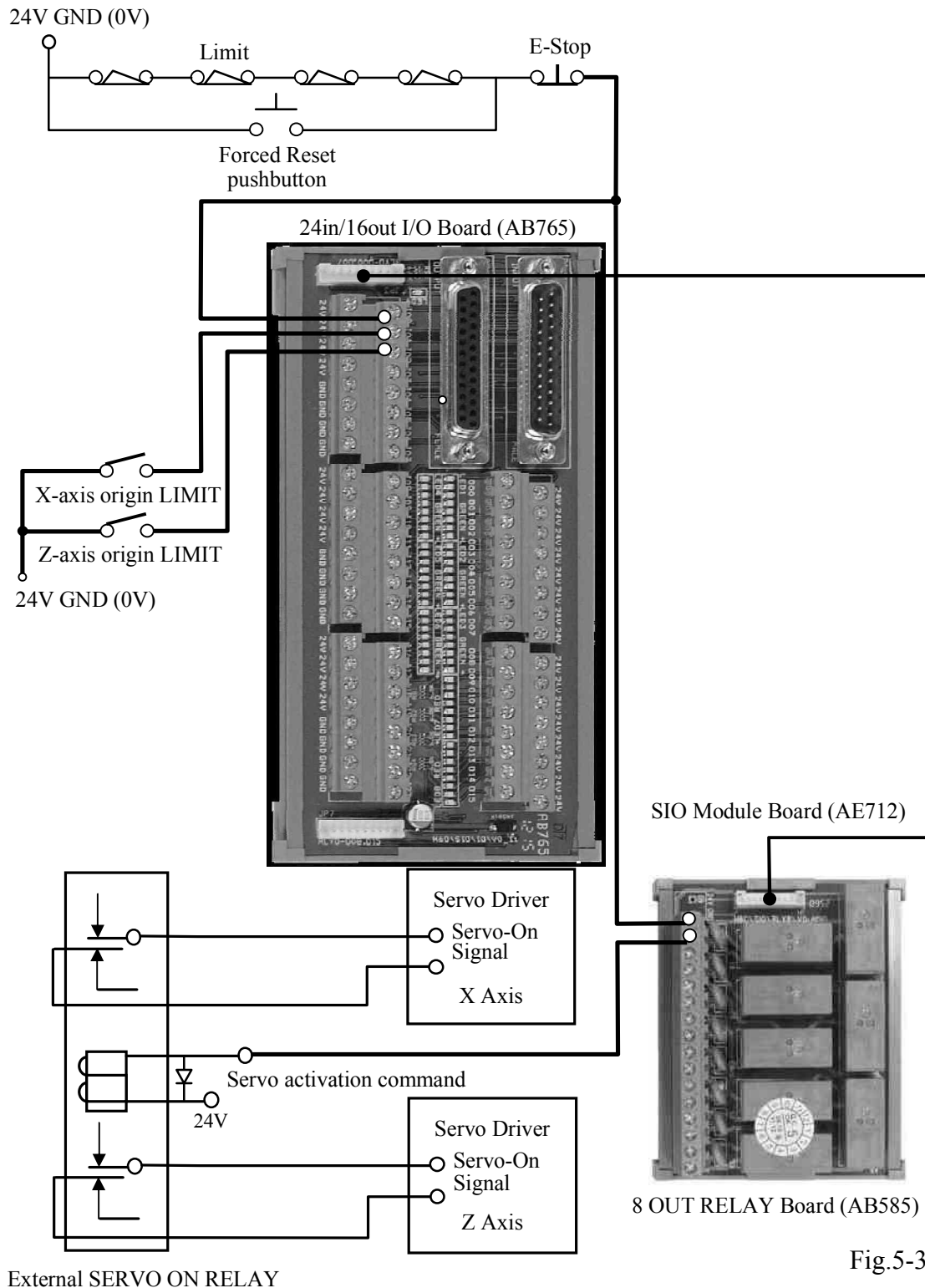

Fig.5-37

* **Convenient Limit and E-Stop**

Convenient Limit and E-Stop

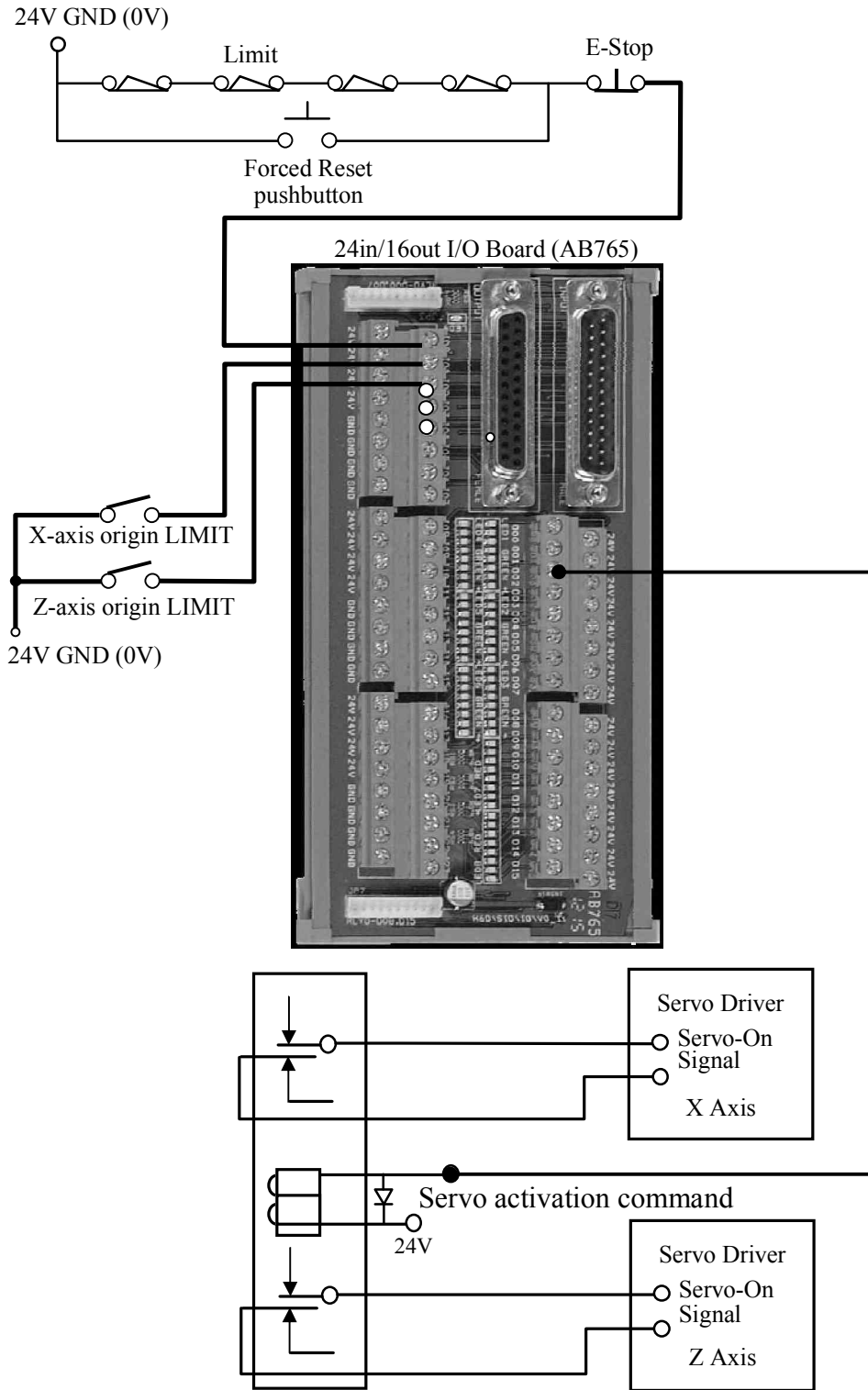

Fig.5-38

* **er en top irin dia ra -**

Con enient irin Dia ra

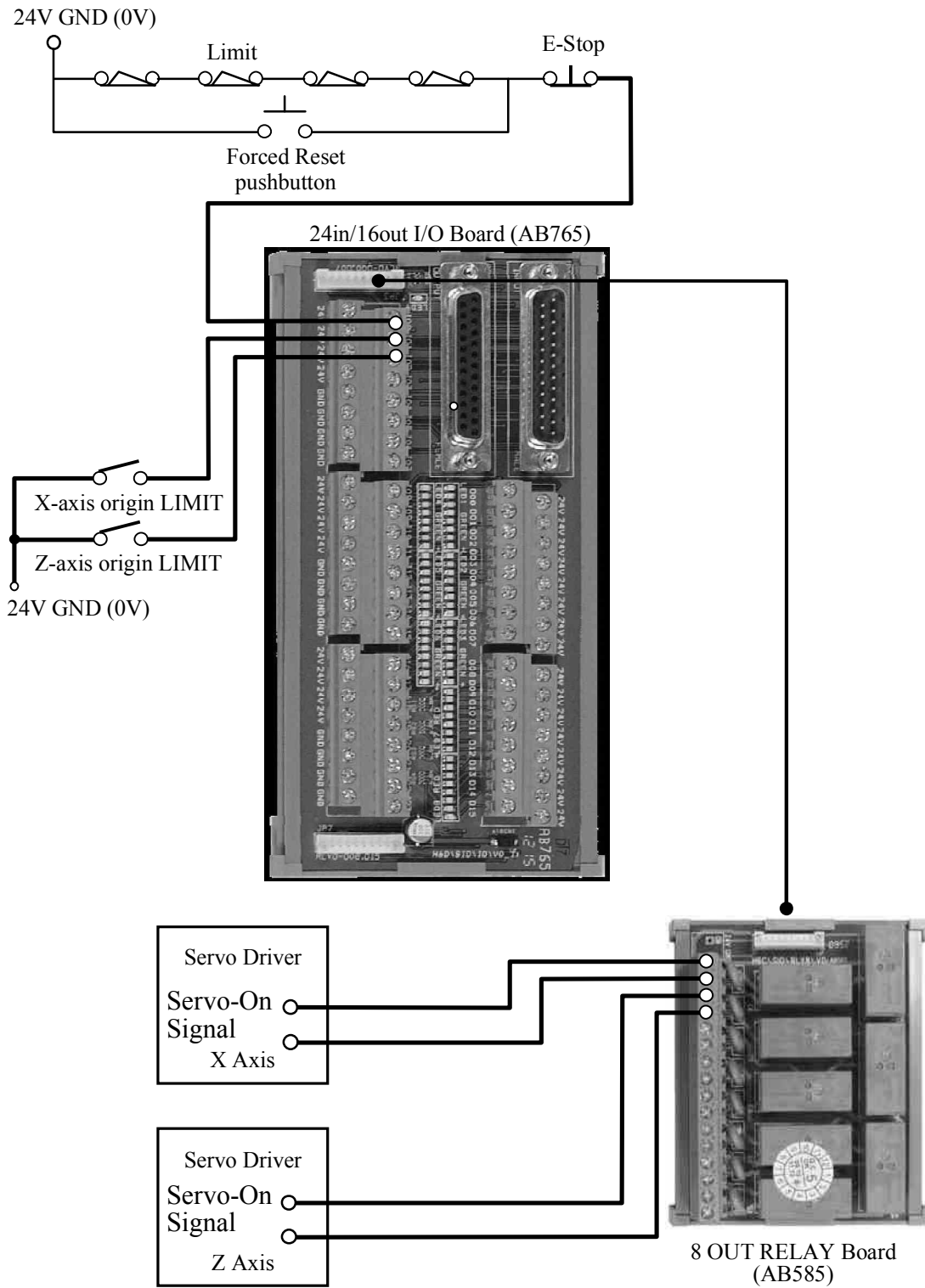

Fig.5-39

* Other □ irin□- □□a□ple 1

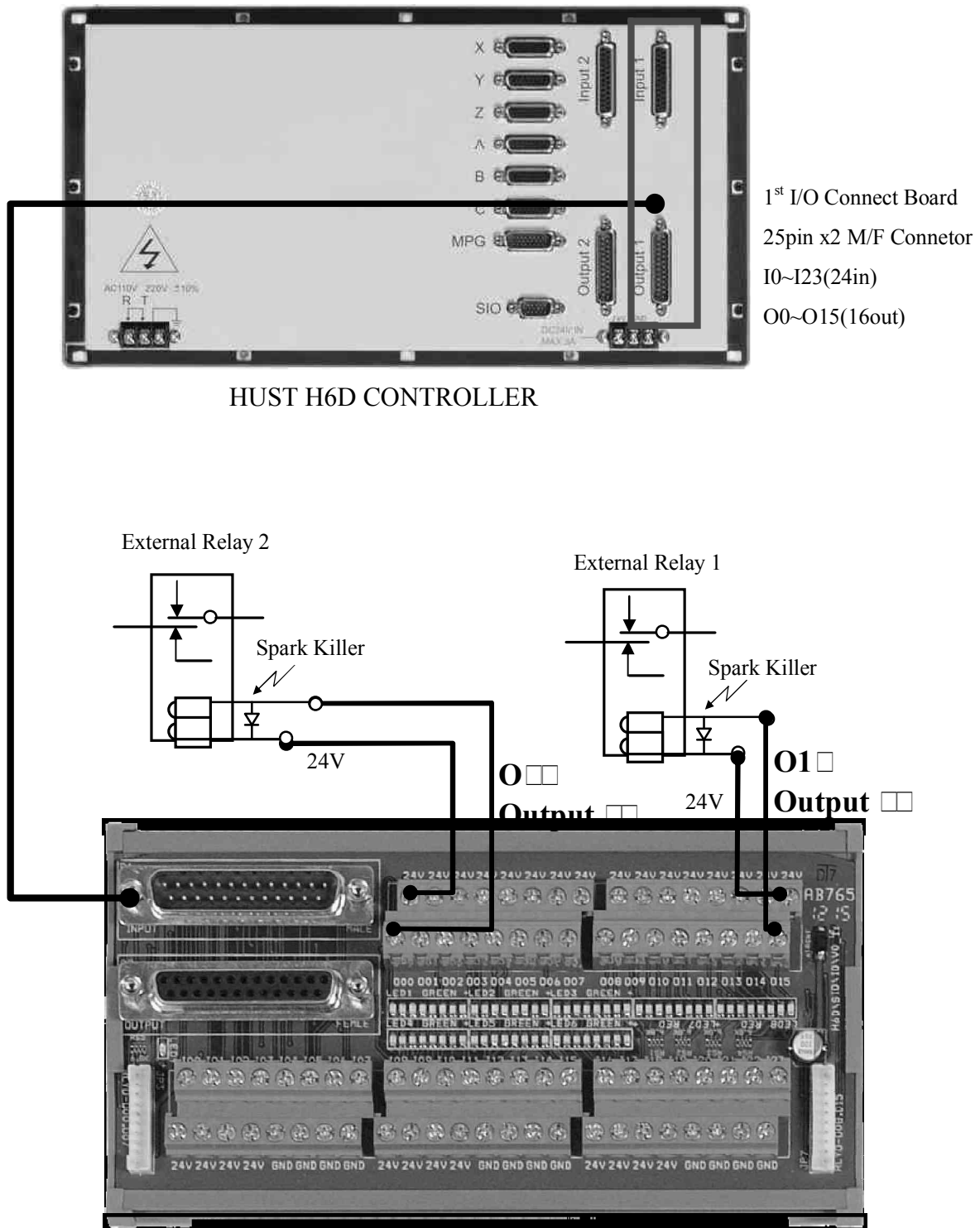

Fig.5-40

* Other irin - a ple 2 Dr Conta f Output

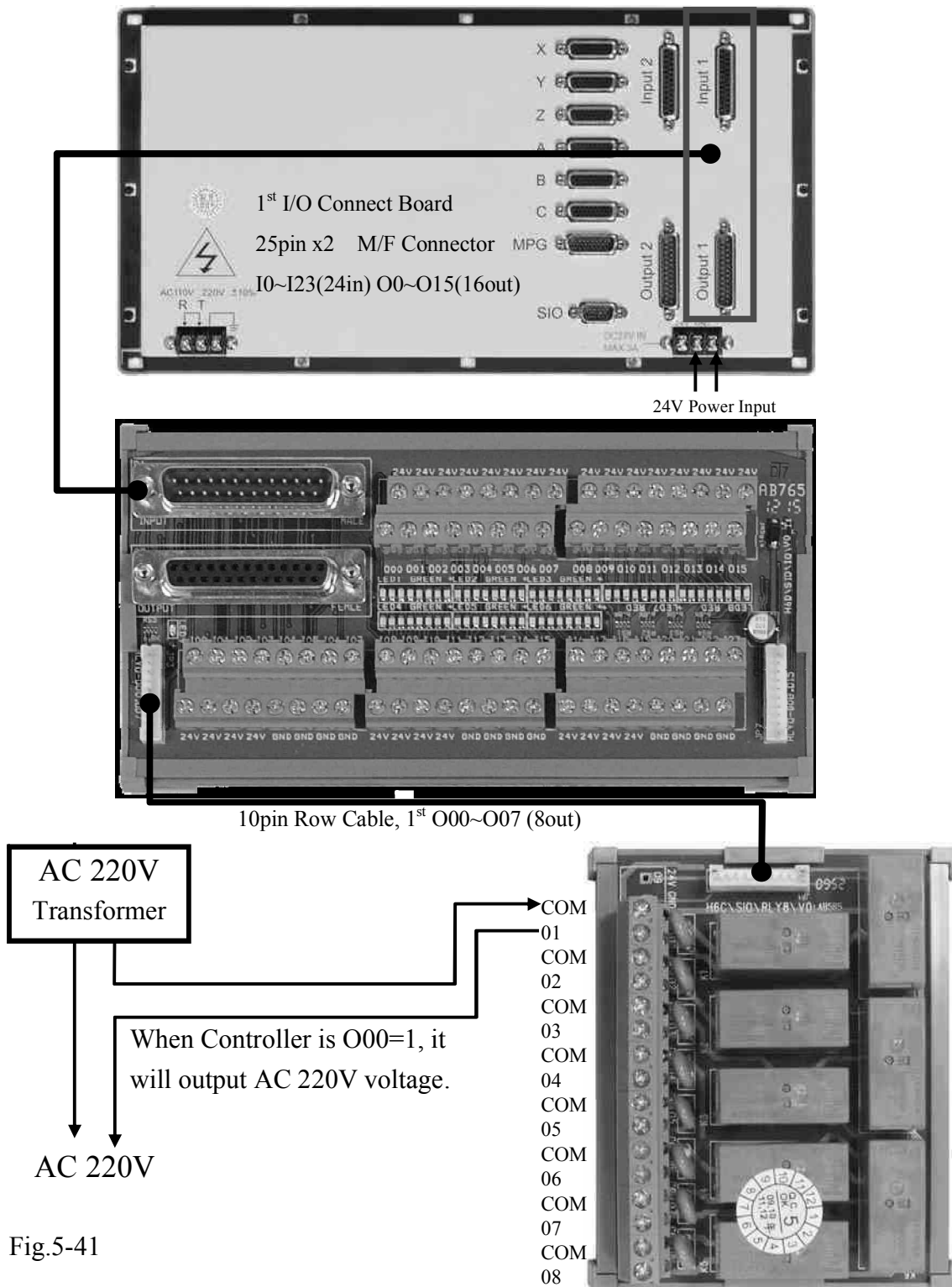

Fig.5-41

- As each COM point is not inter-connected, they should be wired individually when using.
- The external Relay may not be connected that the Relay Board can be used independently.
- As per the figure above, when the Controller is O00=1, it outputs 0V and COM will be connected with 01 in the meantime.

* Other irin-aple DrContaf Output

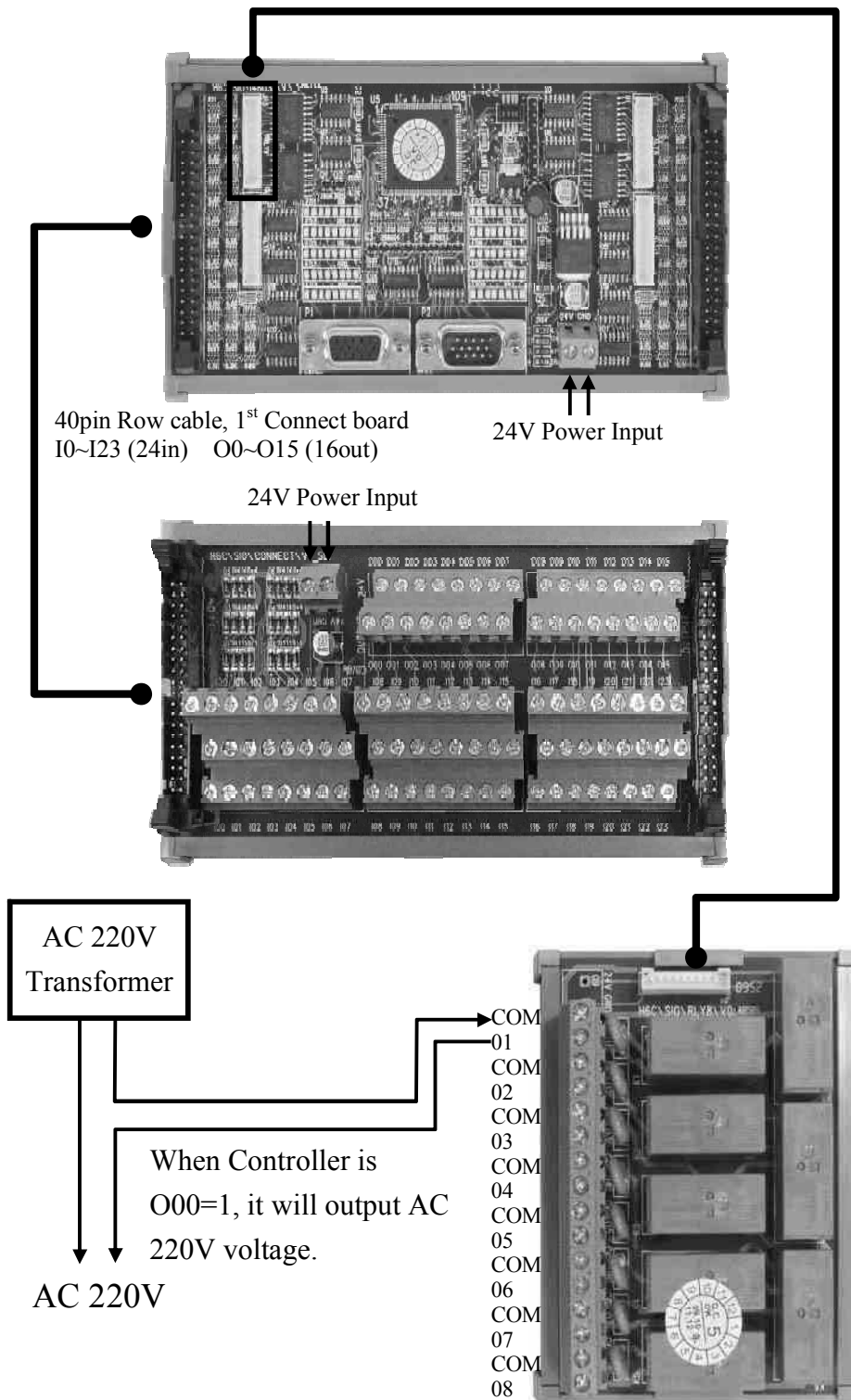

Fig.5-42

*** Other irin- aple DC oer Output**

Single Output Point: The maximum current to be sustained by PC Board will be 1A.
 When using 8 output points simultaneously: The maximum current to be sustained by PC Board will be 8A.

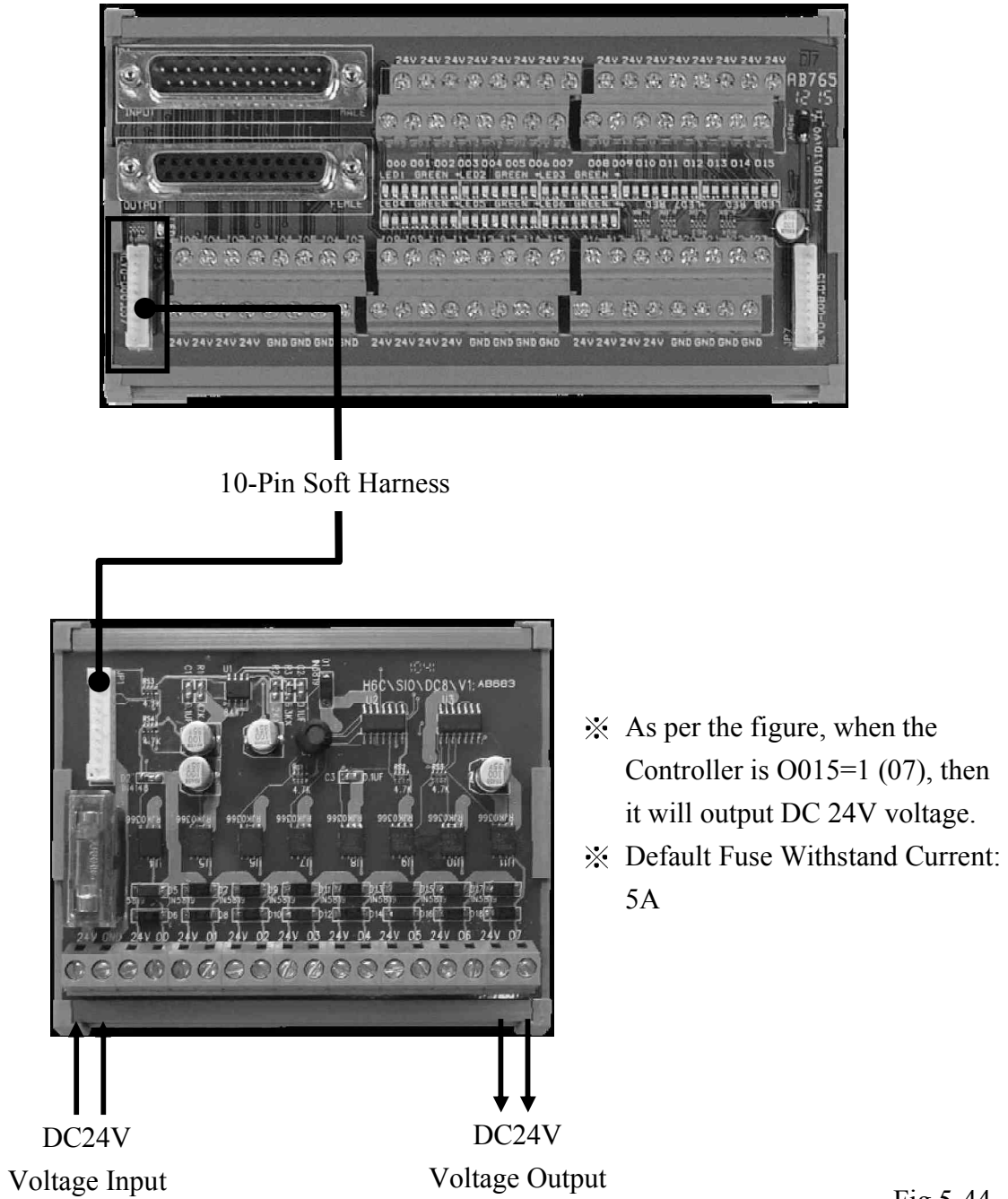

Fig.5-44

* Other irin - a ple 6 N N - ire ensor

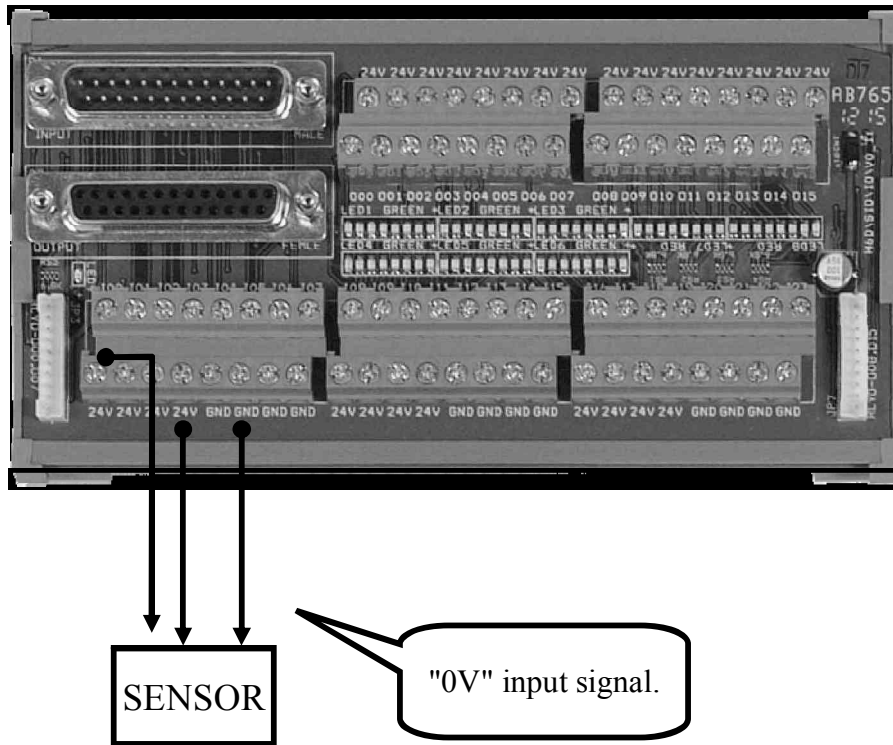

Fig.5-45

* Other irin - a ple N N - ire ensor

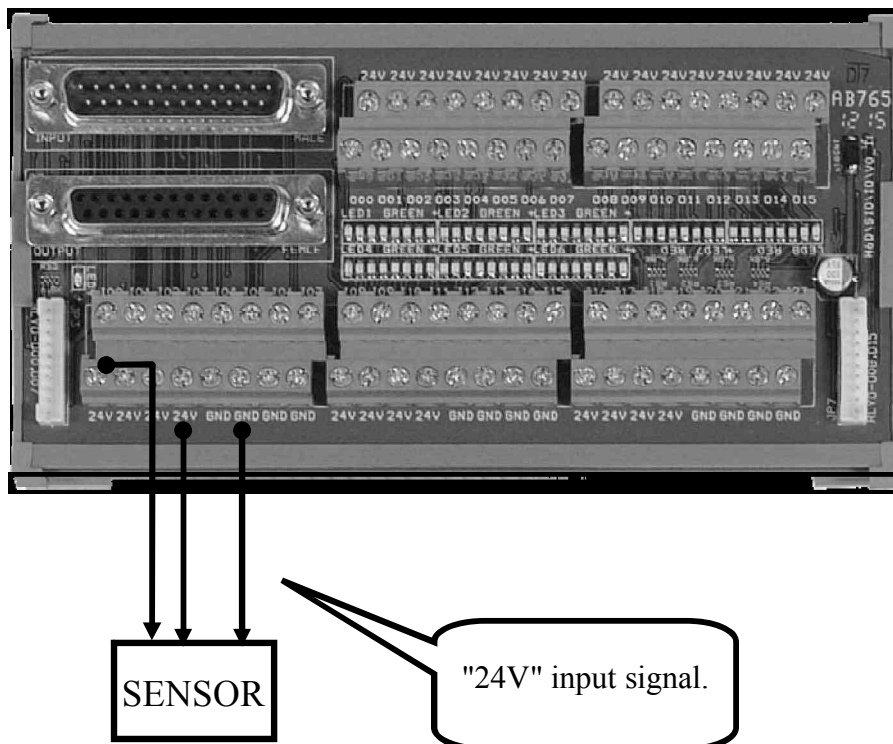
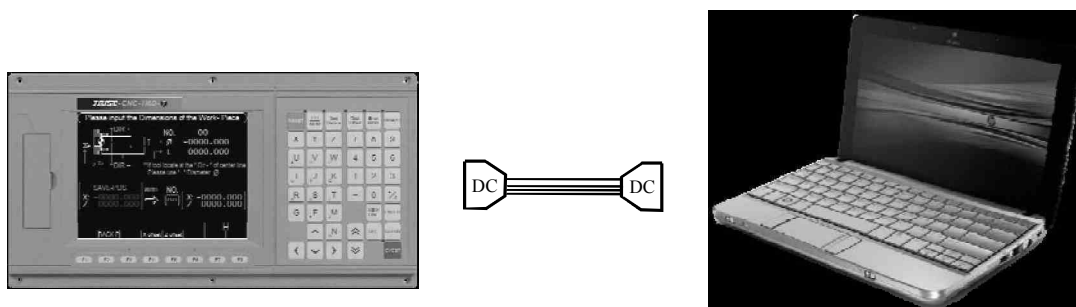

Fig.5-46

*** RS232C Connector pin-out assignment and wiring**

Fig.4-47 shows the connection between the HUST H6D Serial Controller and the computer (PC). When carrying out the wiring, take the following precautions:

1. The RS232C cable shall not exceed a length of 15m.
2. In case of existence of massive noise generators (e.g., EDM processor, welding machine, etc.) in the vicinity, Twist-pair type cables shall be used, or such an environment shall be avoided. The controller and the PC shall NOT share a common power socket with an EDM or welding machine.
3. Make sure the voltage of the interface at the PC end is within the range of 10~15V.



HUST Controller end

PC end COM

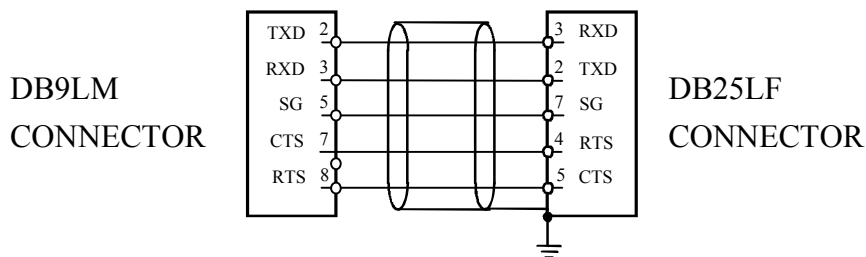

HUST Controller end

PC end COM

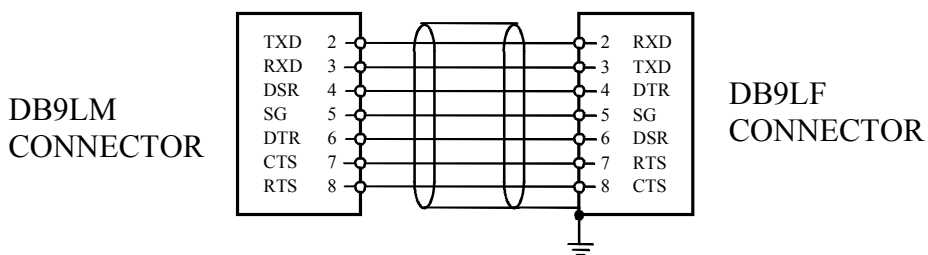

Fig.5-47

6 Error Messages

When an error occurs in the execution of an H□ST H6D series controller□an error message will appear in the LCD screen as shown in Fig.10-1. Possible error messages regarding the H□ST H6D series controller□together with their remedies□are described as follows.

| code | Causes | code | Causes | code | Causes |
|------|------------------------------|------|----------------------------------|-------|---------------------------------|
| 01 | MCM Data Error | 13 | G/M/T code & R error | 32 | G76/G92 E,P command error |
| 02 | Follow error > setting value | 14 | Axis over-travel. | 36 | Data to be transferred in error |
| 04 | USB/SDC error | 15 | Search GRID,distance exceed | 37 | NC alarm(Outside device error) |
| 05 | System error | 18 | End of program error | 38 | Screen reading time > 3 s |
| 07 | Flash rom "write to" error | 20 | Axis reached the software limit. | 39 | Tool life reaching |
| 08 | MDI command error | 22 | Em-Stop | 50 | User defined error (G65) |
| 09 | G31 signal read error | 25 | G02/G03 command error | 53(1) | Tapping retract position error |
| 10 | RS232 error | 28 | G71~G73 command error | 53(2) | Tapping depth < 0 |
| 11 | Program CHECKSUM error. | 29 | G code A,R,C error | 54 | Tapping F (pitch) not defined |
| 12 | Pro. burning >128k | 31 | None PLC | 55 | Tapping depth not defined |

Function Message Field

| | | | |
|---------|--|--|---|
| Spindle | Spindle 1 error Spindle 1 unclamp Coolant pump error Please press SP "cw" or "ccw", before feed-hold cancel | Spindle 2 error Spindle is running | Spindle 3 error Chuck unclamp |
| Feeder | Feeder doesn't meet the positioning | | |
| Other | Turret loose EM-stop X-axis motor error | Tool change time out Hydraulic pump error Y-axis motor error | Count limit is reached Security door error Z-axis motor error |

System Message Field

| | | | | |
|------|------------------------------|----------------|------------|-------|
| 00 | System ERROR message display | Motor not home | 99/99 | 99:99 |
| Back | Main | | Error-LIST | |

Fig.6-1

□ □□□O□

| Error Code | Details | Causes |
|------------|---------|---|
| 01 | | Incorrect MCM parameter setting. |
| | B | Each axis returned to origin□GRID limit of the servo motor □1024. |

Remedy:

1. Check MCM parameter for correct setting or double-press

| |
|------|
| Auto |
| MDI |

 to enter "MDI" mode□execute commend □1□□1□□□ to delete parameter□then re-set parameter.
2. If the controller has rested for more than a year without switching on□the internal memory will disappear. The controller will display

| |
|-----|
| BT1 |
|-----|

□indicating the battery power is low and you need to contact the dealer.
3. The Application Engineer needs to check the PLC to see if C226 is triggered in time after changing the machine parameters.

| Error Code | Details | Causes |
|------------|---------|---|
| 02 | F | F value is too big. |
| | ~C | Axis follow-up error is too big. |
| | S | Spindle follow-up error is too big [3072] |
| | W | When starting the forward-feeding function the error is too big. |
| | D | When starting double-closed circuit control the error is too big. |

Message:

Error happens to the Circuit System where the Servo is located which could lead to the following abnormal situation:

1. The command transmitted by the Controller is too fast that the Servo could not respond in time.
2. The Controller fails to receive the feedback signal.

Remedy:

1. Check the program for excessive setting of F value
2. Check whether the Resolution setting is correct [Check items 241~ 252 MCM parameters]
3. Check if machine or motor is obstructed. Check the wiring.
4. Check Parameter 533 the default value is 4096.
5. Check the wiring condition.

| Error Code | Details | Causes |
|------------|---------|--|
| 03 | L | M99 count exceeds maximum limit [10922][10921] |

Message:

Setting of the M02 M30 or M99 counter exceeds the limit of system variables 10921.

Remedy:

1. Double press "0" button in A TO mode to clear the counting value.
2. Clear the system variable count of 10922 so it returns to 0 then press to remove the error.
3. Or run G10 P201 command in A TO or MDI mode for clearing the system variable 10921 to 0 then press again to clear the error.

| Error Code | Details | Causes |
|------------|---------|----------------------------------|
| 04 | A | SB/SDC error —FR DIS ERR |
| | B | SB/SDC error —FR INT ERR |
| | C | SB/SDC error —FR NOT READ |
| | D | SB/SDC error —FR NO FILE |
| | E | SB/SDC error —FR NO PATH |
| | F | SB/SDC error —FR INVALID NAME |
| | G | SB/SDC error —FR DENIED |
| | H | SB/SDC error —FR E IST |
| | I | SB/SDC error —FR INVALID OBJECT |
| | J | SB/SDC error —FR WRITE PROTECTED |
| | K | SB/SDC error —FR INVALID DRIVE |
| | L | SB/SDC error —FR NOT ENABLED |
| | M | SB/SDC error —FR NO FILES STEM |
| | N | SB/SDC error —FR M FS ABORTED |
| | O | SB/SDC error —FR TIMEO T |

Message :

When switching the transmission mode the system reads the errors of the external storage equipment.

Remedy:

1. Shift the transmission mode back to RS232 Mode and then check if the external transmission equipment such as Panel or SD Card is correctly configured.
2. Make sure the SB is of FAT format and the file extension of the transferred program is correct.
3. Consult the dealer or the manufacturer.

| Error Code | Details | Causes |
|------------|---------|-------------------------|
| 05 | S | Command input is wrong. |

Message :

Command input is wrong.

Remedy :

Check the format of the input command.

| Error Code | Details | Causes |
|------------|---------|--|
| 08 | D | Incorrect Data Address retrieved when executing DNC. |
| | M | MDI command error command size greater than 128bytes |
| | E | Size of current program segment exceeds 128bytes. |

Message :

The length of certain node in the program has exceeded 128 bits.

Remedy:

Check the program and make sure that each segment is within 128 characters.

| Error Code | Details | Causes |
|------------|---------|----------------------------|
| 10 | O | RS232 error —OVERRUN ERROR |
| | P | RS232 error —PARITY ERROR |
| | F | RS232 error —FRAME ERROR |
| | B | RS232 error —BREAK ERROR |
| | N | RS232 error —OTHER ERROR |

Message :

Error exists in the communication signal transmitted by RS232C Port of the Controller.

Remedy:

1. Check transmission speed of controller communication port i.e. parameter 520 of MCM is the same value as that of PC or man-machine interface.
2. Check the communication cables between the controller and the PC or the man-machine interface.

| Error Code | Details | Causes |
|------------|---------|--|
| 11 | I | CHECKSUM error of program |
| | A | SUM error in the Start-up check |
| | D | Program Memory address error DOWN MODE |
| | F | Program Memory is full |
| | | Program Memory address error UP MODE |

Remedy:

Double-press

| |
|------|
| Auto |
| MDI |

 button to enter MDI mode. Run 121 command to clear all the program data check the memory battery. If the controller displays battery low BT1 message you need to replace the battery data in the memory will be lost if the controller remains OFF for more than one year

| Error Code | Details | Causes |
|------------|---------|---|
| 12 | | The size of the burn-in program exceeds the limit H4 Series:56k H6 Standard: 56k~896 lines~64bytes per line H6 Turning/Milling: 56k~128k (saving capacity for function key)~2944 lines. Since the current limit for burn-in is 128k~therefore the maximum size is 128k~2048 lines. |
| | N | The declared command exceeds 20 program lines (G11~G12~G04~M-code). |
| | L | L error in "G10 P0920 Lxxxx" L shall not be empty and 0~LA~1000. |
| | P | Program specified by Lxxxx in "G10 P0921 Lxxxx" has not been declared. |

Message :

The capacity of the replicating program is too big (exceeding 128kB).

Remedy:

1. Check the program for incorrect writing.
2. Check the capacity for the program.

| Error Code | Details | Causes |
|------------|---------|---|
| 13 | G | G error code. During the G87 command, neither of R209 BIT10 and 11 is ON. |
| | T | T error code. |
| | M | M error code (MA~0). |
| | R | An R error in commands G81~G89. ① R and A have different symbols. ② R and A~R have different symbols. |

Message :

The program information contains the "R Error" of G-Code~M-Code or G81-G89 that are not being set by H6D-T Series, and they cannot be accepted by the Controller.

Remedy:

Check the program and check if the R setting of G-Code~M-Code or G81-G89 is correct.

| Error Code | Details | Causes |
|------------|---------------------------------|------------------------------------|
| 14 | □ · · · · · C | □□□□□A□B□or C-axis Hard limit □OT□ |

Message:
Axis Tool exceeds the limit of hardware travel scope.

Remedy:
Manually move the axis into its working range.

| Error Code | Details | Causes |
|------------|---------|--|
| 15 | L | Servo motor returns to Origin to find GRID signal□the distance exceeds the setting range of the parameter. |

Message:
When the axis returns to the Home Position□the Servo cannot locate the GRID signal.

Remedy:

1. Adjust the Sensor position of the Home or set the Grid count in the parameters.
2. Check if the servo feedback line is interrupted.

| Error Code | Details | Causes |
|------------|---------|---------------------------|
| 16 | G | G10P804 Command is wrong. |

Message:
The tapping depth in the G32 Command is “0”.

Remedy:
Check the program content.

| □Error Code | Details | Causes |
|-------------|---------|---|
| 18 | | There have some error in programming occurs when executing the program in A□TO mode. |
| | C | Error of copied segment in the program□cause for the error may be one of the following: 1. Non-existence of the source program. 2. Starting line-no. □Ending line-no. in the source program 3. Starting line-no. □total line-number of the source program 4. Ending line-no. □total line-number of the source program 5. Missing program number in the pasting target. 6. Starting line-no. of the pasting target □total line-number. 7. Memory is full when the pasting content has not been fully pasted. 8. Source program □pasting target program no.□and□ starting line of source program □□starting line no. of pasting target □□ending line no. of source program. |
| | M | Trigger C25 segment data retrieval error: cannot find initial address of specified segment. |
| | T | Failure in finding initial address of specified program. |
| | □ | M95□xxx error □□A is out of 0~127□or □A specified program does not exist□ |
| | L | M99 □ump-back program error □G10P301 specified line-no. error□ |
| | P | Empty CALL in sub-program. □G60...G63□ |

Message :

Program ending is wrong.

Remedy:

1. Check the ending of the program and add M02 or M03 segment.
2. G80 is not filled for the drilling□tapping command ending area.
3. Check the program for excessive si□e.
4. Check for any error in the segment content and in serial setting □N□of the specified segment.

| Error Code | Details | Causes |
|------------|----------------------------|--|
| 20 | □ C | □□□□□A□B□C- axis software OT limit. |
| | N | Number of position limits set in the dynamic range of the software exceeds 4000. |

Remedy:
 Check the program or re-set MCM parameters 581~586 and 601~606 the software travel limits.

| Error Code | Details | Causes |
|------------|---------|-------------------------|
| 22 | | Emergency Stop □C002□1□ |

Remedy:
 After removal of error turn off the Emergency Stop pushbutton followed by pressing the RESET button.

| Error Code | Details | Causes |
|------------|---------|---------------------|
| 24 | | Memory Stack error. |

Remedy:
 Check for repetitive use of CALL subroutine.

| Error Code | Details | Causes |
|------------|---------|--|
| 25 | | G02/G03 command error □Radius of starting point unequal to radius of ending point□ |
| | R | Incorrect input format of R in G02/G03 No displacement in both axes of arc interpolation□or □R□0 in lathe mode□ |
| | L | 2□RAR□□LENGTH□ |
| | G | I□J□R not specified in G02/G03 command. |

Remedy:
 Check the program. Re-calculate arc intersection and verify its coordinates.

| Error Code | Details | Causes |
|------------|---------------|--|
| 27 | . . . C | For ~C when C28=1 and R190 ≠ 0 R190 is the deceleration distance of respective axis after the motor receives the INP of G31. |

Remedy:

1. Check if R190 setting is too short so that it is less than the acceleration distance.
2. Shorten the acceleration/ deceleration time setting **Motor load to e Considered**

| Error Code | Details | Causes |
|------------|---------|---------------------------------------|
| 28 | N | MISSING G70 WITH G7x COMMAND. |
| | W | A DIR. SHOULD BE DIFFERENT FROM G70WA |
| | | A DIR. SHOULD BE DIFFERENT FROM G70A |

Message :

In the program the G71 G72 G73 commands are incorrect or the information format is wrong.

Remedy:

Check the program to see if the G71 G72 G73 commands are wrong set.

| Error Code | Details | Causes |
|------------|---------|--|
| 29 | G | The G code that includes C R or A segment is not G00..G04. |
| | P | Incorrect parameter setting. |
| | A | Incorrect setting of A or its relative parameter. |
| | R | Incorrect setting of R or its relative parameter. |
| | C | Incorrect setting of C or its relative parameter |

Message :

The format of Auto Chamfering Command is wrong.

Remedy:

Check the program to see if “dot” syllable is added in the A R C commands.

| Error Code | Details | Causes |
|------------|---------|--------------|
| 31 | | Missing PLC. |

Remedy:

1. Load the PLC.
2. Consult the dealer or the manufacturer.

| Error Code | Details | Causes |
|------------|---------|---|
| 32 | E | E in G92 is not within the 1.0~100.0 range imperial unit. |
| | P | P in G76 is not within the 30~90 range. |
| | L | End of cutting – preset length max. cutting depth. |
| | D | G76 max. cutting depth 0. |
| | C | CANP-CANPR-CHAM Threading length threading tool withdraw length. |

Remedy:

Check for any error in the cyclic tapping command of the lathe.

| Error Code | Details | Causes |
|------------|---------|---------------------------------------|
| 33 | 4 | xx0 in G34. |
| | 5 | xx0 in G35. |
| | 6 | xx0 in G36. |
| | 7 | Pxx0 or xx0 in G37. |
| | | Execute G35-G36 or G37 in lathe mode. |

Remedy:

Check for any error in setting in commands G34~37 of the lathe.

| Error Code | Details | Causes |
|------------|---------|--|
| 36 | B | Format of SB/SDC file is not 'O8001'. Format of SB/SDC file is not 'O8002'. |
| | C | Format of MCM file is not 'O9002'. |
| | F | Format of function key file is not 'O9140'. Format of variable file is not 'O9004'. |
| | L | Format of PLC file is not 'O9003'. Size of PLC document exceeds upper limit. |
| | P | Input program no. exceeds 1000 [Oxxxx] |
| | R | LENGTH OR S M ERROR 13245 13246 13247 13248. |
| | S | Format of S S file is not 'O9100'. Size of S S document exceeds upper limit. |
| | T | Format of TBL file is not 'O9110'. |
| | W | Input hex file is not in [][][][]0DH format. |

Remedy:

Check for incorrect data transfer format.

| Error Code | Details | Causes |
|------------|---------|---------------------|
| 37 | | NC ALARM [C007] [1] |

Remedy:

Check external control device [remove error and RESET.

| Error Code | Details | Causes |
|------------|---------|--|
| 38 | | Excessive screen display time [3000ms] |

Remedy:

1. Re-transfer screen data file.
2. Consult dealer or manufacturer.

| Error Code | Details | Causes |
|------------|---------|--|
| 41 | | In Tool Offset mode [the command paths between 2 single blocks are 2 parallel lines. |

Message :

The intersection point is lacking between two straight lines when applying the Tip Radius Offset function [G41 [G42]

Remedy:

Check and G41 [G42 commands and analyze the program route and then recalculate.

| Error Code | Details | Causes |
|------------|---------|----------|
| 42 | | OVER CUT |

Message :

The system is presenting overcut condition when applying the Tip Radius Offset function [G41 [G42]

Remedy:

Same as 41.

| Error Code | Details | Causes |
|------------|---------|---|
| 43 | | Insufficient distance between Start and End [0.005] |

Message :

The distance between the starting and ending positions is less than 0.005mm when applying the Tip Radius Offset function [G41 [G42]

Remedy:

Same as 41.

| □rror Code | Details | Causes |
|------------|---------|---|
| 45 | | C251 □0 □Between the single block that the radius of circular arc compensation □0 |

Message :

The transitional arc of the Chamfer between straight line and arc □arc and straight line □ as well as between arcs is less than □ero □“0” □when applying the Tip Radius Offset function □G41 □G42 □

Remedy:
Same as 41.

| □rror Code | Details | Causes |
|------------|---------|---|
| 46 | | In Tool Offset mode □the system fails to determine the center-of-arc when executing an arc command. |

Message :

The intersection point is lacking at the turning corners between straight line and arc and between arc and straight line when applying the Tip Radius Offset function □G41 □G42 □

Remedy:
Same as 41.

| □rror Code | Details | Causes |
|------------|---------|---|
| 47 | | After establishing the Tool makeup function □there will be not intersection point between the turning corner of arcs. |

Message :

The intersection point is lacking at the turning corner between arcs when applying the Tip Radius Offset function □G41 □G42 □

Remedy:
Same as 41.

| □rror Code | Details | Causes |
|------------|---------|---------------------------|
| 48 | | Radius of tool offset □0. |

Message :

The Tip offset value is less than □ero □“0” □when applying the Tip Radius Offset function □G41 □G42 □

Remedy:
Check the G41 □G42 commands □analy□e the program route and reset the Tip offset value.

| Error Code | Details | Causes |
|------------|---------|---|
| 49 | | Direction of tool tip in the lathe is not of the 0~9 type Number of segment of axial displacement is greater than 10 |

Message :

1. More than 6 nodes are lacking of axis displacement command from G41 or G42
[insert offset] to G40 [cancel offset] when applying the Tip Radius Offset function [G41][G42]
2. The Tip orientation is the type other than 0~9 when applying the Tip Radius Offset function [G41][G42]

Remedy :

Adjust the programming method or reset the Tip orientation.

| Error Code | Details | Causes |
|--------------------|---------|---|
| 50 . . 99 | | Customer-defined error alarm using G65. |

Remedy:

Check for any error in the setting of G65 [customer-defined error message].

Functionalar

Motor has not returned to Home Position

Message:

The axis set by the user for returning to the Home Position has failed to return to the Home Position.

Remedy:

Move the failed axis back to the Home Position

Spindle Chuck is not Clamping

Message:

Remedy: If the Spindle Chuck is under loosening status the Controller will send off such alarm when starting the Spindle.

Remedy:

Under MDI Mode clamp the Chuck tightly with M11 Command or press “Manual Chuck” under Manual Mode to hold the Chuck tightly.

Spindle Command Invalid

Message:

Remedy: If the Spindle Chuck is under loosening status the Controller will send off such alarm when giving the Spindle CW/CCW action command.

Remedy:

Clamp the Spindle Chuck first and then give the Spindle action command.

Motor Unusual Signal

Message:

The Servo is operated abnormally.

Remedy:

Check the Motor running status and then remove the Motor alarm.

Turret not Locked

Message:

When the Tool change is in position the system fails to send off the Tool Pan locking signal.

Remedy:

Check the working status of Tool Pan locking signal.

Tool Change Monitoring Overdue

Message:

The time used by Tool change has exceeded the Tool change monitoring time.

Remedy:

Check if the Turret is running or if the Hydraulic Station is working normally. If yes adjust the parameters of “Tool Change Monitor Time” to a moderate range.

Position Limit Alarm

Message:

The axis displacement has exceeded the hardware position limit.

Remedy:

Move the axis toward the opposite direction with Hand Wheel.

□ **Count is 0**

Message:

The working count of the Workpiece has reached the set count.

Remedy:

1. In Auto Display screen briefly press “0” for twice and the working count will be set to zero.
2. Execute M16 command.
3. Press Reset key.
4. Press Start key again.

□ **Hydraulic Station unusual**

Message:

The Hydraulic Station is working abnormally.

Remedy:

Check the working status of the Hydraulic Station.

□ **Oil Filler is abnormal**

Message:

The Oil Filler is working abnormally.

Remedy:

Check the working status of the Oil Filler.

□ **Please Start the Spindle First**

Message:

If the Spindle stops running when the program is under pausing status the System will remind the operator to start the Spindle in order to cancel the pausing status for resuming normal working process.

□ **Coolant unusual**

Message:

The Coolant Pump is working abnormally.

Remedy:

Check if the Coolant Pump is working normally.

7 MCM (Machine Constant) PARAMETERS

HUST H6D/H9D MCM Parameter

H6D / H6DL : X, Y, Z, A, B, C-AXES

H9D / H9DL : X, Y, Z, A, B, C, U, V, W-AXES

| MCM No. | Factory Default Setting | Unit | Description | Setting |
|---------|-------------------------|------|---|---------|
| 1 | 0 | mm | G54 X-axis 1 st Work coordinate (origin) | |
| 2 | 0 | mm | G54 Y-axis 1 st Work coordinate (origin) | |
| 3 | 0 | mm | G54 Z-axis 1 st Work coordinate (origin) | |
| 4 | 0 | mm | G54 A-axis 1 st Work coordinate (origin) | |
| 5 | 0 | mm | G54 B-axis 1 st Work coordinate (origin) | |
| 6 | 0 | mm | G54 C-axis 1 st Work coordinate (origin) | |
| 7 | 0 | mm | G54 U-axis 1 st Work coordinate (origin) | |
| 8 | 0 | mm | G54 V-axis 1 st Work coordinate (origin) | |
| 9 | 0 | mm | G54 W-axis 1 st Work coordinate (origin) | |
| 10-20 | | | System Reserved ! | |
| 21 | 0 | mm | G55 X-axis 2 nd Work coordinate (origin) | |
| 22 | 0 | mm | G55 Y-axis 2 nd Work coordinate (origin) | |
| 23 | 0 | mm | G55 Z-axis 2 nd Work coordinate (origin) | |
| 24 | 0 | mm | G55 A-axis 2 nd Work coordinate (origin) | |
| 25 | 0 | mm | G55 B-axis 2 nd Work coordinate (origin) | |
| 26 | 0 | mm | G55 C-axis 2 nd Work coordinate (origin) | |
| 27 | 0 | mm | G55 U-axis 2 nd Work coordinate (origin) | |
| 28 | 0 | mm | G55 V-axis 2 nd Work coordinate (origin) | |
| 29 | 0 | mm | G55 W-axis 2 nd Work coordinate (origin) | |
| 30-40 | | | System Reserved ! | |
| 41 | 0 | mm | G56 X-axis 3 rd Work coordinate (origin) | |
| 42 | 0 | mm | G56 Y-axis 3 rd Work coordinate (origin) | |
| 43 | 0 | mm | G56 Z-axis 3 rd Work coordinate (origin) | |
| 44 | 0 | mm | G56 A-axis 3 rd Work coordinate (origin) | |
| 45 | 0 | mm | G56 B-axis 3 rd Work coordinate (origin) | |
| 46 | 0 | mm | G56 C-axis 3 rd Work coordinate (origin) | |
| 47 | 0 | mm | G56 U-axis 3 rd Work coordinate (origin) | |
| 48 | 0 | mm | G56 V-axis 3 rd Work coordinate (origin) | |
| 49 | 0 | mm | G56 W-axis 3 rd Work coordinate (origin) | |
| 50-60 | | | System Reserved ! | |
| 61 | 0 | mm | G57 X-axis 4 th Work coordinate (origin) | |
| 62 | 0 | mm | G57 Y-axis 4 th Work coordinate (origin) | |
| 63 | 0 | mm | G57 Z-axis 4 th Work coordinate (origin) | |
| 64 | 0 | mm | G57 A-axis 4 th Work coordinate (origin) | |
| 65 | 0 | mm | G57 B-axis 4 th Work coordinate (origin) | |
| 66 | 0 | mm | G57 C-axis 4 th Work coordinate (origin) | |
| 67 | 0 | mm | G57 U-axis 4 th Work coordinate (origin) | |
| 68 | 0 | mm | G57 V-axis 4 th Work coordinate (origin) | |
| 69 | 0 | mm | G57 W-axis 4 th Work coordinate (origin) | |
| 70-80 | | | System Reserved ! | |
| 81 | 0 | mm | G58 X-axis 5 th Work coordinate (origin) | |
| 82 | 0 | mm | G58 Y-axis 5 th Work coordinate (origin) | |
| 83 | 0 | mm | G58 Z-axis 5 th Work coordinate (origin) | |
| 84 | 0 | mm | G58 A-axis 5 th Work coordinate (origin) | |

| MCM No. | Factory Default Setting | Unit | Description | Setting |
|---------|-------------------------|------|---|---------|
| 85 | 0 | mm | G58 B-axis 5 th Work coordinate (origin) | |
| 86 | 0 | mm | G58 C-axis 5 th Work coordinate (origin) | |
| 87 | 0 | mm | G58 U-axis 5 th Work coordinate (origin) | |
| 88 | 0 | mm | G58 V-axis 5 th Work coordinate (origin) | |
| 89 | 0 | mm | G58 W-axis 5 th Work coordinate (origin) | |
| 90-100 | | | System Reserved ! | |
| 101 | 0 | mm | G59 X-axis 6 th Work coordinate (origin) | |
| 102 | 0 | mm | G59 Y-axis 6 th Work coordinate (origin) | |
| 103 | 0 | mm | G59 Z-axis 6 th Work coordinate (origin) | |
| 104 | 0 | mm | G59 A-axis 6 th Work coordinate (origin) | |
| 105 | 0 | mm | G59 B-axis 6 th Work coordinate (origin) | |
| 106 | 0 | mm | G59 C-axis 6 th Work coordinate (origin) | |
| 107 | 0 | mm | G59 U-axis 6 th Work coordinate (origin) | |
| 108 | 0 | mm | G59 V-axis 6 th Work coordinate (origin) | |
| 109 | 0 | mm | G59 W-axis 6 th Work coordinate (origin) | |
| 110-120 | | | System Reserved ! | |
| 121 | 0 | mm | X-axis, G28 reference point coordinate | |
| 122 | 0 | mm | Y-axis, G28 reference point coordinate | |
| 123 | 0 | mm | Z-axis, G28 reference point coordinate | |
| 124 | 0 | mm | A-axis, G28 reference point coordinate | |
| 125 | 0 | mm | B-axis, G28 reference point coordinate | |
| 126 | 0 | mm | C-axis, G28 reference point coordinate | |
| 127 | 0 | mm | U-axis, G28 reference point coordinate | |
| 128 | 0 | mm | V-axis, G28 reference point coordinate | |
| 129 | 0 | mm | W-axis, G28 reference point coordinate | |
| 130-140 | | | System Reserved ! | |
| 141 | 0 | mm | X-axis, G30 reference point coordinate | |
| 142 | 0 | mm | Y-axis, G30 reference point coordinate | |
| 143 | 0 | mm | Z-axis, G30 reference point coordinate | |
| 144 | 0 | mm | A-axis, G30 reference point coordinate | |
| 145 | 0 | mm | B-axis, G30 reference point coordinate | |
| 146 | 0 | mm | C-axis, G30 reference point coordinate | |
| 147 | 0 | mm | U-axis, G30 reference point coordinate | |
| 148 | 0 | mm | V-axis, G30 reference point coordinate | |
| 149 | 0 | mm | W-axis, G30 reference point coordinate | |
| 150-160 | | | System Reserved ! | |
| 161 | 0 | mm | X-axis, Backlash compensation (G01), 0~9.999 | |
| 162 | 0 | mm | Y-axis, Backlash compensation (G01), 0~9.999 | |
| 163 | 0 | mm | Z-axis, Backlash compensation (G01), 0~9.999 | |
| 164 | 0 | mm | A-axis, Backlash compensation (G01), 0~9.999 | |
| 165 | 0 | mm | B-axis, Backlash compensation (G01), 0~9.999 | |
| 166 | 0 | mm | C-axis, Backlash compensation (G01), 0~9.999 | |
| 167 | 0 | mm | U-axis, Backlash compensation (G01), 0~9.999 | |
| 168 | 0 | mm | V-axis, Backlash compensation (G01), 0~9.999 | |
| 169 | 0 | mm | W-axis, Backlash compensation (G01), 0~9.999 | |
| 170-180 | | | System Reserved ! | |
| 181 | 0 | mm | X-axis, Backlash compensation (G00), 0~9.999 | |
| 182 | 0 | mm | Y-axis, Backlash compensation (G00), 0~9.999 | |
| 183 | 0 | mm | Z-axis, Backlash compensation (G00), 0~9.999 | |
| 184 | 0 | mm | A-axis, Backlash compensation (G00), 0~9.999 | |
| 185 | 0 | mm | B-axis, Backlash compensation (G00), 0~9.999 | |
| 186 | 0 | mm | C-axis, Backlash compensation (G00), 0~9.999 | |

| MCM No. | Factory Default Setting | Unit | Description | Setting |
|---------|-------------------------|--------|---|---------|
| 187 | 0 | mm | U-axis, Backlash compensation (G00), 0~9.999 | |
| 188 | 0 | mm | V-axis, Backlash compensation (G00), 0~9.999 | |
| 189 | 0 | mm | W-axis, Backlash compensation (G00), 0~9.999 | |
| 190-200 | | | System Reserved ! | |
| 201 | 1000 | mm/min | X-axis, JOG Feed-rate | |
| 202 | 1000 | mm/min | Y-axis, JOG Feed-rate | |
| 203 | 1000 | mm/min | Z-axis, JOG Feed-rate | |
| 204 | 1000 | mm/min | A-axis, JOG Feed-rate | |
| 205 | 1000 | mm/min | B-axis, JOG Feed-rate | |
| 206 | 1000 | mm/min | C-axis, JOG Feed-rate | |
| 207 | 1000 | mm/min | U-axis, JOG Feed-rate | |
| 208 | 1000 | mm/min | V-axis, JOG Feed-rate | |
| 209 | 1000 | mm/min | W-axis, JOG Feed-rate | |
| 210-220 | | | System Reserved ! | |
| 221 | 10000 | mm/min | X-axis, G00 Traverse speed limit | |
| 222 | 10000 | mm/min | Y-axis, G00 Traverse speed limit | |
| 223 | 10000 | mm/min | Z-axis, G00 Traverse speed limit | |
| 224 | 10000 | mm/min | A-axis, G00 Traverse speed limit | |
| 225 | 10000 | mm/min | B-axis, G00 Traverse speed limit | |
| 226 | 10000 | mm/min | C-axis, G00 Traverse speed limit | |
| 227 | 10000 | mm/min | U-axis, G00 Traverse speed limit | |
| 228 | 10000 | mm/min | V-axis, G00 Traverse speed limit | |
| 229 | 10000 | mm/min | W-axis, G00 Traverse speed limit | |
| 230-240 | | | System Reserved ! | |
| 241 | 100 | pulse | X-axis,Denominator,resolution calc.(Encoder pulse) | |
| 242 | 100 | μm | X-axis,Numerator,resolution calculation.(Ball-screwpitch) | |
| 243 | 100 | pulse | Y-axis,Denominator,resolutioncalc.(Encoder pulse) | |
| 244 | 100 | μm | Y-axis,Numerator,resolutioncalc.(Ball-screwpitch) | |
| 245 | 100 | pulse | Z-axis,Denominator,resolutioncalc.(Encoder pulse) | |
| 246 | 100 | μm | Z-axis,Numerator,resolutioncalc.(Ball-screwpitch) | |
| 247 | 100 | pulse | A-axis,Denominator,resolutioncalc.(Encoder pulse) | |
| 248 | 100 | μm | A-axis,Numerator,resolutioncalc.(Ball-screwpitch) | |
| 249 | 100 | pulse | B-axis,Denominator,resolutioncalc.(Encoder pulse) | |
| 250 | 100 | μm | B-axis,Numerator,resolutioncalc.(Ball-screwpitch) | |
| 251 | 100 | pulse | C-axis,Denominator,resolutioncalc.(Encoder pulse) | |
| 252 | 100 | μm | C-axis,Numerator,resolutioncalc.(Ball-screwpitch) | |
| 253 | 100 | pulse | U-axis,Denominator,resolutioncalc.(Encoder pulse) | |
| 254 | 100 | μm | U-axis,Numerator,resolutioncalc.(Ball-screwpitch) | |
| 255 | 100 | pulse | V-axis,Denominator,resolutioncalc.(Encoder pulse) | |
| 256 | 100 | μm | V-axis,Numerator,resolutioncalc.(Ball-screwpitch) | |
| 257 | 100 | pulse | W-axis,Denominator,resolutioncalc.(Encoder pulse) | |
| 258 | 100 | μm | W-axis,Numerator,resolutioncalc.(Ball-screwpitch) | |
| 259-280 | | | System Reserved ! | |
| 281 | 0 | | X-axis, HOME direction, 0=+ dir. 1=-dir | |
| 282 | 0 | | Y-axis, HOME direction, 0=+ dir. 1=-dir | |
| 283 | 0 | | Z-axis, HOME direction, 0=+ dir. 1=-dir | |
| 284 | 0 | | A-axis, HOME direction, 0=+ dir. 1=-dir | |
| 285 | 0 | | B-axis, HOME direction, 0=+ dir. 1=-dir | |
| 286 | 0 | | C-axis, HOME direction, 0=+ dir. 1=-dir | |
| 287 | 0 | | U-axis, HOME direction, 0=+ dir. 1=-dir | |
| 288 | 0 | | V-axis, HOME direction, 0=+ dir. 1=-dir | |
| 289 | 0 | | W-axis, HOME direction, 0=+ dir. 1=-dir | |

| MCM No. | Factory Default Setting | Unit | Description | Setting |
|---------|-------------------------|--------|--|---------|
| 287-300 | | | System Reserved ! | |
| 301 | 2500 | mm/min | X-axis, HOME speed 1 | |
| 302 | 2500 | mm/min | Y-axis, HOME speed 1 | |
| 303 | 2500 | mm/min | Z-axis, HOME speed 1 | |
| 304 | 2500 | mm/min | A-axis, HOME speed 1 | |
| 305 | 2500 | mm/min | B-axis, HOME speed 1 | |
| 306 | 2500 | mm/min | C-axis, HOME speed 1 | |
| 207 | 2500 | mm/min | U-axis, HOME speed 1 | |
| 308 | 2500 | mm/min | V-axis, HOME speed 1 | |
| 309 | 2500 | mm/min | W-axis, HOME speed 1 | |
| 310-320 | | | System Reserved ! | |
| 321 | 40 | mm/min | X-axis, Home grid speed during HOME execution | |
| 322 | 40 | mm/min | Y-axis, Home grid speed during HOME execution | |
| 323 | 40 | mm/min | Z-axis, Home grid speed during HOME execution | |
| 324 | 40 | mm/min | A-axis, Home grid speed during HOME execution | |
| 325 | 40 | mm/min | B-axis, Home grid speed during HOME execution | |
| 326 | 40 | mm/min | C-axis, Home grid speed during HOME execution | |
| 327 | 40 | mm/min | U-axis, Home grid speed during HOME execution | |
| 328 | 40 | mm/min | V-axis, Home grid speed during HOME execution | |
| 329 | 40 | mm/min | W-axis, Home grid speed during HOME execution | |
| 330-340 | | | System Reserved ! | |
| 341 | 0 | 0/1 | X-axis,Home grid direction during HOME execution | |
| 342 | 0 | 0/1 | Y-axis,Home grid direction during HOME execution | |
| 343 | 0 | 0/1 | Z-axis,Home grid direction during HOME execution | |
| 344 | 0 | 0/1 | A-axis,Home grid direction during HOME execution | |
| 345 | 0 | 0/1 | B-axis,Home grid direction during HOME execution | |
| 346 | 0 | 0/1 | C-axis,Home grid direction during HOME execution | |
| 347 | 0 | 0/1 | U-axis,Home grid direction during HOME execution | |
| 348 | 0 | 0/1 | V-axis,Home grid direction during HOME execution | |
| 349 | 0 | 0/1 | W-axis,Home grid direction during HOME execution | |
| 350-360 | | | System Reserved ! | |
| 361 | 0 | mm | X-axis Home grid setting | |
| 362 | 0 | mm | Y-axis Home grid setting | |
| 363 | 0 | mm | Z-axis Home grid setting | |
| 364 | 0 | mm | A-axis Home grid setting | |
| 365 | 0 | mm | B-axis Home grid setting | |
| 366 | 0 | mm | C-axis Home grid setting | |
| 367 | 0 | mm | U-axis Home grid setting | |
| 368 | 0 | mm | V-axis Home grid setting | |
| 369 | 0 | mm | W-axis Home grid setting | |
| 370-380 | | | System Reserved ! | |
| 381 | 0 | mm | X-axis, HOME shift data | |
| 382 | 0 | mm | Y-axis, HOME shift data | |
| 383 | 0 | mm | Z-axis, HOME shift data | |
| 384 | 0 | mm | A-axis, HOME shift data | |
| 385 | 0 | mm | B-axis, HOME shift data | |
| 386 | 0 | mm | C-axis, HOME shift data | |
| 387 | 0 | mm | U-axis, HOME shift data | |
| 388 | 0 | mm | V-axis, HOME shift data | |
| 389 | 0 | mm | W-axis, HOME shift data | |
| 390-400 | | | System Reserved ! | |
| 401 | 10.000 | mm | X-axis,Setting the value of search servo grid | |

| MCM No. | Factory Default Setting | Unit | Description | Setting |
|---------|-------------------------|------|---|---------|
| 402 | 10.000 | mm | Y-axis,Setting the value of search servo grid | |
| 403 | 10.000 | mm | Z-axis,Setting the value of search servo grid | |
| 404 | 10.000 | mm | A-axis,Setting the value of search servo grid | |
| 405 | 10.000 | mm | B-axis,Setting the value of search servo grid | |
| 406 | 10.000 | mm | C-axis,Setting the value of search servo grid | |
| 407 | 10.000 | mm | U-axis,Setting the value of search servo grid | |
| 408 | 10.000 | mm | V-axis,Setting the value of search servo grid | |
| 409 | 10.000 | mm | W-axis,Setting the value of search servo grid | |
| 410-420 | 0 | | System Reserved ! | |
| 421 | 0 | | X-axis Origin switch (+ :N.O (normallyopen) node; -:N.C (normally closed) node) | |
| 422 | 0 | | Y-axis Origin switch (+ :N.O node; -:N.C node) | |
| 423 | 0 | | Z-axis Origin switch (+ :N.O node; -:N.C node) | |
| 424 | 0 | | A-axis Origin switch (+ :N.O node; -:N.C node) | |
| 425 | 0 | | B-axis Origin switch (+ :N.O node; -:N.C node) | |
| 426 | 0 | | C-axis Origin switch (+ :N.O node; -:N.C node) | |
| 427 | 0 | | U-axis Origin switch (+ :N.O node; -:N.C node) | |
| 428 | 0 | | V-axis Origin switch (+ :N.O node; -:N.C node) | |
| 429 | 0 | | W-axis Origin switch (+ :N.O node; -:N.C node) | |
| 430-440 | | | System Reserved ! | |
| 441 | 0 | | X-axis, Direction of motor rotation, 0=CW, 1=CCW | |
| 442 | 0 | | Y-axis, Direction of motor rotation, 0=CW, 1=CCW | |
| 443 | 0 | | Z-axis, Direction of motor rotation, 0=CW, 1=CCW | |
| 444 | 0 | | A-axis, Direction of motor rotation, 0=CW, 1=CCW | |
| 445 | 0 | | B-axis, Direction of motor rotation, 0=CW, 1=CCW | |
| 446 | 0 | | C-axis, Direction of motor rotation, 0=CW, 1=CCW | |
| 447 | 0 | | U-axis, Direction of motor rotation, 0=CW, 1=CCW | |
| 448 | 0 | | V-axis, Direction of motor rotation, 0=CW, 1=CCW | |
| 449 | 0 | | W-axis, Direction of motor rotation, 0=CW, 1=CCW | |
| 450-460 | | | System Reserved ! | |
| 461 | 4 | | X-axis,Encoder pulse multiplicationfactor,1,2,or 4 | |
| 462 | 4 | | Y-axis,Encoder pulse multiplicationfactor,1,2,or 4 | |
| 463 | 4 | | Z-axis,Encoder pulse multiplicationfactor,1,2,or 4 | |
| 464 | 4 | | A-axis,Encoder pulse multiplicationfactor,1,2,or 4 | |
| 465 | 4 | | B-axis,Encoder pulse multiplicationfactor,1,2,or 4 | |
| 466 | 4 | | C-axis,Encoder pulse multiplicationfactor,1,2,or 4 | |
| 467 | 4 | | U-axis,Encoder pulse multiplicationfactor,1,2,or 4 | |
| 468 | 4 | | V-axis,Encoder pulse multiplicationfactor,1,2,or 4 | |
| 469 | 4 | | W-axis,Encoder pulse multiplicationfactor,1,2,or 4 | |
| 470-480 | | | System Reserved ! | |
| 481 | 5 | | X-axis impulse command width adjustment (4=625KPPS) | |
| 482 | 5 | | Y-axis impulse command width adjustment (4=625KPPS) | |
| 483 | 5 | | Z-axis impulse command width adjustment (4=625KPPS) | |
| 484 | 5 | | A-axis impulse command width adjustment (4=625KPPS) | |
| 485 | 5 | | B-axis impulse command width adjustment (4=625KPPS) | |
| 486 | 5 | | C-axis impulse command width adjustment (4=625KPPS) | |
| 487 | 5 | | U-axis impulse command width adjustment (4=625KPPS) | |
| 488 | 5 | | V-axis impulse command width adjustment (4=625KPPS) | |
| 489 | 5 | | W-axis impulse command width adjustment (4=625KPPS) | |
| 490-500 | 6 | | System Reserved ! | |
| 501 | 0 | | Master/Slave mode, 0=CNC, 1=X-axis, 2=Y-axis 3=Z-axis,4=A-axis,5=B-axis,6=C-axis,7=U-axis, | |

| MCM No. | Factory Default Setting | Unit | Description | Setting |
|---------|-------------------------|-------|---|---------|
| | | | 8=V-axis, 9=w-axis, 256= non-stop mode in a single block | |
| 502 | 0 | | Accel/Decel mode,0=exponential,1=linear,2="S" curve | |
| 503 | 0 | | Home command mode setting. | |
| | | | BIT0 = 0 , X axis find Home grid available, = 1 , no need to find. | |
| | | | BIT1 = 0 , Y axis find Home grid available, = 1 , no need to find. | |
| | | | BIT2 = 0 , Z axis find Home grid available, = 1 , no need to find. | |
| | | | BIT3 = 0 , A axis find Home grid available, = 1 , no need to find. | |
| | | | BIT4 = 0 , B axis find Home grid available, = 1 , no need to find. | |
| | | | BIT5 = 0 , C axis find Home grid available, = 1 , no need to find. | |
| | | | BIT6 = 0 , U axis find Home grid available, = 1 , no need to find. | |
| | | | BIT7 = 0 , V axis find Home grid available, = 1 , no need to find. | |
| | | | BIT8 = 0 , W axis find Home grid available, = 1 , no need to find. | |
| 504 | 100 | msec | G00 Linear accel./decel. Time, 4~512 ms | |
| 505 | 100 | msec | G01 Linear accel./decel. Time, 10~1024 ms | |
| 506 | 100 | msec | Accel/Decel time when in G99 mode (mm/rev) | |
| 507 | 100 | msec | Time Setting for spindle acceleration | |
| 508 | 0 | | System Reserved ! | |
| 509 | 4096 | pulse | Spindle encoder resolution (pulse/rev) | |
| 510 | 3000 | rpm | Max. spindle rpm at 10 volts | |
| 511 | 0 | v | Spindle voltage command zero drift correction (open circuit) | |
| 512 | 0 | | Spindle voltage command acce/dece slope correction (open circuit) | |
| 513 | 0 | rpm | Spindle RPM correction (based on feedback from the encoder) | |
| 514 | 0 | | Start number for program block number generation | |
| 515 | 0 | | Increment for program block number generation | |
| 516 | 1 | | Denominator of feed-rate when in MPG test mode | |
| 517 | 1 | | Numerator of feed-rate when in MPG test mode | |
| 518 | 0 | | MPG direction | |
| 519 | 64 | ms | Set Acceleration/Deceleration Time for MPG (4~512) | |
| 520 | 38400 | | RS232 Baud rate, 38400, 19200 / EVEN /2 Bit | |
| 521 | 0 | | Setting whether R000~R99 data in PLC are stored when power is cut off. 0=NO, 256=YES | |
| 522 | 0 | pulse | Servo Error Counter | |
| 523 | 0 | | Radius/Diameter Programming mode | |
| 524 | 0 | | 0=Metric mode, 25400=inch mode mcm541=0,1 | |
| 525 | 3 | | Error in Circular Cutting, ideal value=1 | |
| 526 | 0 | | Pulse settings 0: pulse + direction 1: +/- pulse 2: A/B phase | |
| 527 | 1000 | | Setting G01 speed value at booting | |
| 528 | 0 | | Setting tool compensation direction =1 FAUNC, =0 HUST | |
| 529 | 0 | | It is used for adjusting the G01's acceleration/deceleration time when the acceleration/deceleration type is set to an "S" curve. | |

| MCM No. | Factory Default Setting | Unit | Description | Setting |
|---------|-------------------------|-------|---|---------|
| | | | When MCM 502=2, the function can then be sustained. | |
| 530 | 0 | | G31 input motion stop at hardware | |
| 531 | 0 | | Format setting =0 standard, =1 the system will automatically add a decimal point to even numbers, =2 line editing, =4 automatically added with a decimal point in programming | |
| 532 | 2.000 | mm | Mill mode ; Setting the backlash of G83 | |
| 533 | 4096 | pulse | Setting the following error count for testing | |
| 534 | | | Testing the function of axial setting of the servo following error (bit0-X..) | |
| 535 | | | Controller ID number | |
| 536 | | | Minimum slope setting of the Auto Teach function (with use of C040) | |
| 537 | | | First distance setting of the Auto Teach function (with use of C040) | |
| 538 | 0 | | G41 and G42 processing types | |
| 539 | | | System reserved | |
| 540 | 0 | | Adjustment of the axis feedback direction. | |
| 541 | 0 | | Arc type | |
| 541-560 | | | System Reserved ! | |
| 561 | 0 | | "S" curve accel./decel. profile setting for the X-axis | |
| 562 | 0 | | "S" curve accel./decel. profile setting for the Y-axis | |
| 563 | 0 | | "S" curve accel./decel. profile setting for the Z-axis | |
| 564 | 0 | | "S" curve accel./decel. profile setting for the A-axis | |
| 565 | 0 | | "S" curve accel./decel. profile setting for the B-axis | |
| 566 | 0 | | "S" curve accel./decel. profile setting for the C-axis | |
| 567 | 0 | | "S" curve accel./decel. profile setting for the U-axis | |
| 568 | 0 | | "S" curve accel./decel. profile setting for the V-axis | |
| 569 | 0 | | "S" curve accel./decel. profile setting for the W-axis | |
| 570~580 | | | System Reserved ! | |
| 581 | 9999999 | mm | X-axis, Software OT limit, (+) direction (Group 1) | |
| 582 | 9999999 | mm | Y-axis, Software OT limit, (+) direction (Group 1) | |
| 583 | 9999999 | mm | Z-axis, Software OT limit, (+) direction (Group 1) | |
| 584 | 9999999 | mm | A-axis, Software OT limit, (+) direction (Group 1) | |
| 585 | 9999999 | mm | B-axis, Software OT limit, (+) direction (Group 1) | |
| 586 | 9999999 | mm | C-axis, Software OT limit, (+) direction (Group 1) | |
| 587 | 9999999 | mm | U-axis, Software OT limit, (+) direction (Group 1) | |
| 588 | 9999999 | mm | V-axis, Software OT limit, (+) direction (Group 1) | |
| 589 | 9999999 | mm | W-axis, Software OT limit, (+) direction (Group 1) | |
| 590-600 | | | System Reserved ! | |
| 601 | -9999999 | mm | X-axis, Software OT limit, (-) direction (Group 1) | |
| 602 | -9999999 | mm | Y-axis, Software OT limit, (-) direction (Group 1) | |
| 603 | -9999999 | mm | Z-axis, Software OT limit, (-) direction (Group 1) | |
| 604 | -9999999 | mm | A-axis, Software OT limit, (-) direction (Group 1) | |
| 605 | -9999999 | mm | B-axis, Software OT limit, (-) direction (Group 1) | |
| 606 | -9999999 | mm | C-axis, Software OT limit, (-) direction (Group 1) | |
| 607 | -9999999 | mm | U-axis, Software OT limit, (-) direction (Group 1) | |
| 608 | -9999999 | mm | V-axis, Software OT limit, (-) direction (Group 1) | |
| 609 | -9999999 | mm | W-axis, Software OT limit, (-) direction (Group 1) | |

| MCM No. | Factory Default Setting | Unit | Description | Setting |
|---------|-------------------------|-------|--|---------|
| 610-620 | | | System Reserved ! | |
| 621 | 9999999 | mm | X-axis, Software OT limit, (+) direction (Group 2) | |
| 622 | 9999999 | mm | Y-axis, Software OT limit, (+) direction (Group 2) | |
| 623 | 9999999 | mm | Z-axis, Software OT limit, (+) direction (Group 2) | |
| 624 | 9999999 | mm | A-axis, Software OT limit, (+) direction (Group 2) | |
| 625 | 9999999 | mm | B-axis, Software OT limit, (+) direction (Group 2) | |
| 626 | 9999999 | mm | C-axis, Software OT limit, (+) direction (Group 2) | |
| 627 | 9999999 | mm | U-axis, Software OT limit, (+) direction (Group 2) | |
| 628 | 9999999 | mm | V-axis, Software OT limit, (+) direction (Group 2) | |
| 629 | 9999999 | mm | W-axis, Software OT limit, (+) direction (Group 2) | |
| 630-640 | | | System Reserved ! | |
| 641 | -9999999 | mm | X-axis, Software OT limit, (-) direction (Group 2) | |
| 642 | -9999999 | mm | Y-axis, Software OT limit, (-) direction (Group 2) | |
| 643 | -9999999 | mm | Z-axis, Software OT limit, (-) direction (Group 2) | |
| 644 | -9999999 | mm | A-axis, Software OT limit, (-) direction (Group 2) | |
| 645 | -9999999 | mm | B-axis, Software OT limit, (-) direction (Group 2) | |
| 646 | -9999999 | mm | C-axis, Software OT limit, (-) direction (Group 2) | |
| 647 | -9999999 | mm | U-axis, Software OT limit, (-) direction (Group 2) | |
| 648 | -9999999 | mm | V-axis, Software OT limit, (-) direction (Group 2) | |
| 649 | -9999999 | mm | W-axis, Software OT limit, (-) direction (Group 2) | |
| 650-660 | | | System Reserved ! | |
| 661 | 0 | | X-axis, Cycle clearing w/ M02, M30, M99 | |
| 662 | 0 | | Y-axis, Cycle clearing w/ M02, M30, M99 | |
| 663 | 0 | | Z-axis, Cycle clearing w/ M02, M30, M99 | |
| 664 | 0 | | A-axis, Cycle clearing w/ M02, M30, M99 | |
| 665 | 0 | | B-axis, Cycle clearing w/ M02, M30, M99 | |
| 666 | 0 | | C-axis, Cycle clearing w/ M02, M30, M99 | |
| 667 | 0 | | U-axis, Cycle clearing w/ M02, M30, M99 | |
| 668 | 0 | | V-axis, Cycle clearing w/ M02, M30, M99 | |
| 669 | 0 | | W-axis, Cycle clearing w/ M02, M30, M99 | |
| 670-680 | 0 | | System Reserved ! | |
| 681 | 1 | | X-axis,0=incrementalcoord.,1=absolute coordinate | |
| 682 | 1 | | Y-axis,0=incrementalcoord.,1=absolute coordinate | |
| 683 | 1 | | Z-axis,0=incrementalcoord.,1=absolute coordinate | |
| 684 | 1 | | A-axis,0=incrementalcoord.,1=absolute coordinate | |
| 685 | 1 | | B-axis,0=incrementalcoord.,1=absolute coordinate | |
| 686 | 1 | | C-axis,0=incrementalcoord.,1=absolute coordinate | |
| 687 | 1 | | U-axis,0=incrementalcoord.,1=absolute coordinate | |
| 688 | 1 | | V-axis,0=incrementalcoord.,1=absolute coordinate | |
| 689 | 1 | | W-axis,0=incrementalcoord.,1=absolute coordinate | |
| 690-700 | 1 | | System Reserved ! | |
| 701 | 64 | pulse | X-axis, Position gain, standard=64 | |
| 702 | 64 | pulse | Y-axis, Position gain, standard=64 | |
| 703 | 64 | pulse | Z-axis, Position gain, standard=64 | |
| 704 | 64 | pulse | A-axis, Position gain, standard=64 | |
| 705 | 64 | pulse | B-axis, Position gain, standard=64 | |
| 706 | 64 | pulse | C-axis, Position gain, standard=64 | |
| 707 | 64 | pulse | U-axis, Position gain, standard=64 | |
| 708 | 64 | pulse | V-axis, Position gain, standard=64 | |
| 709 | 64 | pulse | W-axis, Position gain, standard=64 | |
| 710-720 | 64 | pulse | System Reserved ! | |
| 721 | 10 | pulse | X-axis,Break-over point for position gain, std=10 | |

| MCM No. | Factory Default Setting | Unit | Description | Setting |
|---------|-------------------------|-------|--|---------|
| 722 | 10 | pulse | Y-axis,Break-over point for position gain, std=10 | |
| 723 | 10 | pulse | Z-axis,Break-over point for position gain, std=10 | |
| 724 | 10 | pulse | A-axis,Break-over point for position gain, std=10 | |
| 725 | 10 | pulse | B-axis,Break-over point for position gain, std=10 | |
| 726 | 10 | pulse | C-axis,Break-over point for position gain, std=10 | |
| 727 | 10 | pulse | U-axis,Break-over point for position gain, std=10 | |
| 728 | 10 | pulse | V-axis,Break-over point for position gain, std=10 | |
| 729 | 10 | pulse | W-axis,Break-over point for position gain, std=10 | |
| 727-740 | 10 | pulse | System Reserved ! | |
| 741 | 100 | | X-axis, Denominator, MPG resolution calc. | |
| 742 | 100 | | X-axis, Numerator, MPG resolution calc. | |
| 743 | 100 | | Y-axis, Denominator, MPG resolution calc. | |
| 744 | 100 | | Y-axis, Numerator, MPG resolution calc. | |
| 745 | 100 | | Z-axis, Denominator, MPG resolution calc. | |
| 746 | 100 | | Z-axis, Numerator, MPG resolution calc. | |
| 747 | 100 | | A-axis, Denominator, MPG resolution calc. | |
| 748 | 100 | | A-axis, Numerator, MPG resolution calc. | |
| 749 | 100 | | B-axis, Denominator, MPG resolution calc. | |
| 750 | 100 | | B-axis, Numerator, MPG resolution calc. | |
| 751 | 100 | | C-axis, Denominator, MPG resolution calc. | |
| 752 | 100 | | C-axis, Numerator, MPG resolution calc. | |
| 753 | 100 | | U-axis, Denominator, MPG resolution calc. | |
| 754 | 100 | | U-axis, Numerator, MPG resolution calc. | |
| 755 | 100 | | V-axis, Denominator, MPG resolution calc. | |
| 756 | 100 | | V-axis, Numerator, MPG resolution calc. | |
| 757 | 100 | | W-axis, Denominator, MPG resolution calc. | |
| 758 | 100 | | W-axis, Numerator, MPG resolution calc. | |
| 760-780 | | | System Reserved ! | |
| 781 | 0 | | Set X-axis as Rotating (1) / Linear axis (0) | |
| 782 | 0 | | Set Y-axis as Rotating (1) / Linear axis (0) | |
| 783 | 0 | | Set Z-axis as Rotating (1) / Linear axis (0) | |
| 784 | 0 | | Set A-axis as Rotating (1) / Linear axis (0) | |
| 785 | 0 | | Set B-axis as Rotating (1) / Linear axis (0) | |
| 786 | 0 | | Set C-axis as Rotating (1) / Linear axis (0) | |
| 787 | 0 | | Set U-axis as Rotating (1) / Linear axis (0) | |
| 788 | 0 | | Set V-axis as Rotating (1) / Linear axis (0) | |
| 789 | 0 | | Set W-axis as Rotating (1) / Linear axis (0) | |
| 790-800 | | | System Reserved ! | |
| 801 | 0 · 000 | mm | Distance of S bit sent before the X-axis reaches in position. (S176) | |
| 802 | 0 · 000 | mm | Distance of S bit sent before the Y-axis reaches in position. (S177) | |
| 803 | 0 · 000 | mm | Distance of S bit sent before the Z-axis reaches in position. (S178) | |
| 804 | 0 · 000 | mm | Distance of S bit sent before the A-axis reaches in position. (S179) | |
| 805 | 0 · 000 | mm | Distance of S bit sent before the B-axis reaches in position. (S180) | |
| 806 | 0 · 000 | mm | Distance of S bit sent before the C-axis reaches in position. (S181) | |
| 807 | 0 · 000 | mm | Distance of S bit sent before the U-axis reaches in position. (S182) | |
| 808 | 0 · 000 | mm | Distance of S bit sent before the V-axis reaches in position. (S183) | |
| 809 | 0 · 000 | mm | Distance of S bit sent before the W-axis reaches in position. (S184) | |
| 810-820 | | | System Reserved ! | |
| 821 | 0 | msec | Set Acceleration/Deceleration Time for X-axis | |
| 822 | 0 | msec | Set Acceleration/Deceleration Time for Y-axis | |
| 823 | 0 | msec | Set Acceleration/Deceleration Time for Z-axis | |

| MCM No. | Factory Default Setting | Unit | Description | Setting |
|-----------|-------------------------|------|---|---------|
| 824 | 0 | msec | Set Acceleration/Deceleration Time for A-axis | |
| 825 | 0 | msec | Set Acceleration/Deceleration Time for B-axis | |
| 826 | 0 | msec | Set Acceleration/Deceleration Time for C-axis | |
| 827 | 0 | msec | Set Acceleration/Deceleration Time for U-axis | |
| 828 | 0 | msec | Set Acceleration/Deceleration Time for V-axis | |
| 829 | 0 | msec | Set Acceleration/Deceleration Time for W-axis | |
| 830-840 | | | System Reserved ! | |
| 841 | 0 | | X-axis allowable compensation of back screw pitch | |
| 842 | 0 | | Y-axis allowable compensation of back screw pitch | |
| 843 | 0 | | Z-axis allowable compensation of back screw pitch | |
| 844 | 0 | | A-axis allowable compensation of back screw pitch | |
| 845 | 0 | | B-axis allowable compensation of back screw pitch | |
| 846 | 0 | | C-axis allowable compensation of back screw pitch | |
| 847 | 0 | | U-axis allowable compensation of back screw pitch | |
| 848 | 0 | | V-axis allowable compensation of back screw pitch | |
| 849 | 0 | | W-axis allowable compensation of back screw pitch | |
| 847-850 | 0 | | System Reserved ! | |
| 851 | 20000 | mm | X-axis length compensation of back screw pitch | |
| 852 | 20000 | mm | Y-axis length compensation of back screw pitch | |
| 853 | 20000 | mm | Z-axis length compensation of back screw pitch | |
| 854 | 20000 | mm | A-axis length compensation of back screw pitch | |
| 855 | 20000 | mm | B-axis length compensation of back screw pitch | |
| 856 | 20000 | mm | C-axis length compensation of back screw pitch | |
| 857~860 | | | System Reserved ! | |
| 861-940 | 0 | | X-axis,Pitch error compensation of each segment. | |
| 941-1020 | 0 | | Y-axis,Pitch error compensation of each segment. | |
| 1021-1100 | 0 | | Z-axis,Pitch error compensation of each segment. | |
| 1101-1180 | 0 | | A-axis,Pitch error compensation of each segment. | |
| 1181-1260 | 0 | | B-axis,Pitch error compensation of each segment. | |
| 1261-1340 | 0 | | C-axis,Pitch error compensation of each segment. | |
| 1341 | 0 | mm | Tool #1 radius compensation | |
| 1342 | 0 | mm | X-axis, Tool #1 offset compensation | |
| 1343 | 0 | mm | Y-axis, Tool #1 offset compensation | |
| 1344 | 0 | mm | Z-axis, Tool #1 offset compensation | |
| 1345 | 0 | mm | A-axis, Tool #1 offset compensation | |
| 1346 | 0 | mm | B-axis, Tool #1 offset compensation | |
| 1347 | 0 | mm | C-axis, Tool #1 offset compensation | |
| 1348 | 0 | mm | Tool #2 radius compensation | |
| 1349 | 0 | mm | X-axis, Tool #2 offset compensation | |
| 1350 | 0 | mm | Y-axis, Tool #2 offset compensation | |
| 1351 | 0 | mm | Z-axis, Tool #2 offset compensation | |
| 1352 | 0 | mm | A-axis, Tool #2 offset compensation | |
| 1353 | 0 | mm | B-axis, Tool #2 offset compensation | |
| 1354 | 0 | mm | C-axis, Tool #2 offset compensation | |
| 1355 | 0 | mm | Tool #3 radius compensation | |
| 1356 | 0 | mm | X-axis, Tool #3 offset compensation | |
| 1357 | 0 | mm | Y-axis, Tool #3 offset compensation | |
| 1358 | 0 | mm | Z-axis, Tool #3 offset compensation | |
| 1359 | 0 | mm | A-axis, Tool #3 offset compensation | |
| 1360 | 0 | mm | B-axis, Tool #3 offset compensation | |
| 1361 | 0 | mm | C-axis, Tool #3 offset compensation | |
| 1362 | 0 | mm | Tool #4 radius compensation | |

| MCM No. | Factory Default Setting | Unit | Description | Setting |
|---------|-------------------------|------|--------------------------------------|---------|
| 1363 | 0 | mm | X-axis, Tool #4 offset compensation | |
| 1364 | 0 | mm | Y-axis, Tool #4 offset compensation | |
| 1365 | 0 | mm | Z-axis, Tool #4 offset compensation | |
| 1366 | 0 | mm | A-axis, Tool #4 offset compensation | |
| 1367 | 0 | mm | B-axis, Tool #4 offset compensation | |
| 1368 | 0 | mm | C-axis, Tool #4 offset compensation | |
| 1369 | 0 | mm | Tool #5 radius compensation | |
| 1370 | 0 | mm | X-axis, Tool #5 offset compensation | |
| 1371 | 0 | mm | Y-axis, Tool #5 offset compensation | |
| 1372 | 0 | mm | Z-axis, Tool #5 offset compensation | |
| 1373 | 0 | mm | A-axis, Tool #5 offset compensation | |
| 1374 | 0 | mm | B-axis, Tool #5 offset compensation | |
| 1375 | 0 | mm | C-axis, Tool #5 offset compensation | |
| 1376 | 0 | mm | Tool #6 radius compensation | |
| 1377 | 0 | mm | X-axis, Tool #6 offset compensation | |
| 1378 | 0 | mm | Y-axis, Tool #6 offset compensation | |
| 1379 | 0 | mm | Z-axis, Tool #6 offset compensation | |
| 1380 | 0 | mm | A-axis, Tool #6 offset compensation | |
| 1381 | 0 | mm | B-axis, Tool #6 offset compensation | |
| 1382 | 0 | mm | C-axis, Tool #6 offset compensation | |
| 1383 | 0 | mm | Tool #7 radius compensation | |
| 1384 | 0 | mm | X-axis, Tool #7 offset compensation | |
| 1385 | 0 | mm | Y-axis, Tool #7 offset compensation | |
| 1386 | 0 | mm | Z-axis, Tool #7 offset compensation | |
| 1387 | 0 | mm | A-axis, Tool #7 offset compensation | |
| 1388 | 0 | mm | B-axis, Tool #7 offset compensation | |
| 1389 | 0 | mm | C-axis, Tool #7 offset compensation | |
| 1390 | 0 | mm | Tool #8 radius compensation | |
| 1391 | 0 | mm | X-axis, Tool #8 offset compensation | |
| 1392 | 0 | mm | Y-axis, Tool #8 offset compensation | |
| 1393 | 0 | mm | Z-axis, Tool #8 offset compensation | |
| 1394 | 0 | mm | A-axis, Tool #8 offset compensation | |
| 1395 | 0 | mm | B-axis, Tool #8 offset compensation | |
| 1396 | 0 | mm | C-axis, Tool #8 offset compensation | |
| 1397 | 0 | mm | Tool #9 radius compensation | |
| 1398 | 0 | mm | X-axis, Tool #9 offset compensation | |
| 1399 | 0 | mm | Y-axis, Tool #9 offset compensation | |
| 1400 | 0 | mm | Z-axis, Tool #9 offset compensation | |
| 1401 | 0 | mm | A-axis, Tool #9 offset compensation | |
| 1402 | 0 | mm | B-axis, Tool #9 offset compensation | |
| 1403 | 0 | mm | C-axis, Tool #9 offset compensation | |
| 1404 | 0 | mm | Tool #10 radius compensation | |
| 1405 | 0 | mm | X-axis, Tool #10 offset compensation | |
| 1406 | 0 | mm | Y-axis, Tool #10 offset compensation | |
| 1407 | 0 | mm | Z-axis, Tool #10 offset compensation | |
| 1408 | 0 | mm | A-axis, Tool #10 offset compensation | |
| 1409 | 0 | mm | B-axis, Tool #10 offset compensation | |
| 1410 | 0 | mm | C-axis, Tool #10 offset compensation | |
| 1411 | 0 | mm | Tool #11 radius compensation | |
| 1412 | 0 | mm | X-axis, Tool #11 offset compensation | |
| 1413 | 0 | mm | Y-axis, Tool #11 offset compensation | |
| 1414 | 0 | mm | Z-axis, Tool #11 offset compensation | |
| 1415 | 0 | mm | A-axis, Tool #11 offset compensation | |

| MCM No. | Factory Default Setting | Unit | Description | Setting |
|---------|-------------------------|------|--------------------------------------|---------|
| 1416 | 0 | mm | B-axis, Tool #11 offset compensation | |
| 1417 | 0 | mm | C-axis, Tool #11 offset compensation | |
| 1418 | 0 | mm | Tool #12 radius compensation | |
| 1419 | 0 | mm | X-axis, Tool #12 offset compensation | |
| 1420 | 0 | mm | Y-axis, Tool #12 offset compensation | |
| 1421 | 0 | mm | Z-axis, Tool #12 offset compensation | |
| 1422 | 0 | mm | A-axis, Tool #12 offset compensation | |
| 1423 | 0 | mm | B-axis, Tool #12 offset compensation | |
| 1424 | 0 | mm | C-axis, Tool #12 offset compensation | |
| 1425 | 0 | mm | Tool #13 radius compensation | |
| 1426 | 0 | mm | X-axis, Tool #13 offset compensation | |
| 1427 | 0 | mm | Y-axis, Tool #13 offset compensation | |
| 1428 | 0 | mm | Z-axis, Tool #13 offset compensation | |
| 1429 | 0 | mm | A-axis, Tool #13 offset compensation | |
| 1430 | 0 | mm | B-axis, Tool #13 offset compensation | |
| 1431 | 0 | mm | C-axis, Tool #13 offset compensation | |
| 1432 | 0 | mm | Tool #14 radius compensation | |
| 1433 | 0 | mm | X-axis, Tool #14 offset compensation | |
| 1434 | 0 | mm | Y-axis, Tool #14 offset compensation | |
| 1435 | 0 | mm | Z-axis, Tool #14 offset compensation | |
| 1436 | 0 | mm | A-axis, Tool #14 offset compensation | |
| 1437 | 0 | mm | B-axis, Tool #14 offset compensation | |
| 1438 | 0 | mm | C-axis, Tool #14 offset compensation | |
| 1439 | 0 | mm | Tool # radius compensation | |
| 1440 | 0 | mm | X-axis, Tool #15 offset compensation | |
| 1441 | 0 | mm | Y-axis, Tool #15 offset compensation | |
| 1442 | 0 | mm | Z-axis, Tool #15 offset compensation | |
| 1443 | 0 | mm | A-axis, Tool #15 offset compensation | |
| 1444 | 0 | mm | B-axis, Tool #15 offset compensation | |
| 1445 | 0 | mm | C-axis, Tool #15 offset compensation | |
| 1446 | 0 | mm | Tool #16 radius compensation | |
| 1447 | 0 | mm | X-axis, Tool #16 offset compensation | |
| 1448 | 0 | mm | Y-axis, Tool #16 offset compensation | |
| 1449 | 0 | mm | Z-axis, Tool #16 offset compensation | |
| 1450 | 0 | mm | A-axis, Tool #16 offset compensation | |
| 1451 | 0 | mm | B-axis, Tool #16 offset compensation | |
| 1452 | 0 | mm | C-axis, Tool #16 offset compensation | |
| 1453 | 0 | mm | Tool #17 radius compensation | |
| 1454 | 0 | mm | X-axis, Tool #17 offset compensation | |
| 1455 | 0 | mm | Y-axis, Tool #17 offset compensation | |
| 1456 | 0 | mm | Z-axis, Tool #17 offset compensation | |
| 1457 | 0 | mm | A-axis, Tool #17 offset compensation | |
| 1458 | 0 | mm | B-axis, Tool #17 offset compensation | |
| 1459 | 0 | mm | C-axis, Tool #17 offset compensation | |
| 1460 | 0 | mm | Tool #18 radius compensation | |
| 1461 | 0 | mm | X-axis, Tool #18 offset compensation | |
| 1462 | 0 | mm | Y-axis, Tool #18 offset compensation | |
| 1463 | 0 | mm | Z-axis, Tool #18 offset compensation | |
| 1464 | 0 | mm | A-axis, Tool #18 offset compensation | |
| 1465 | 0 | mm | B-axis, Tool #18 offset compensation | |
| 1466 | 0 | mm | C-axis, Tool #18 offset compensation | |
| 1467 | 0 | mm | Tool #19 radius compensation | |
| 1468 | 0 | mm | X-axis, Tool #19 offset compensation | |

| MCM No. | Factory Default Setting | Unit | Description | Setting |
|---------|-------------------------|------|--------------------------------------|---------|
| 1469 | 0 | mm | Y-axis, Tool #19 offset compensation | |
| 1470 | 0 | mm | Z-axis, Tool #19 offset compensation | |
| 1471 | 0 | mm | A-axis, Tool #19 offset compensation | |
| 1472 | 0 | mm | B-axis, Tool #19 offset compensation | |
| 1473 | 0 | mm | C-axis, Tool #19 offset compensation | |
| 1474 | 0 | mm | Tool #20 radius compensation | |
| 1475 | 0 | mm | X-axis, Tool #20 offset compensation | |
| 1476 | 0 | mm | Y-axis, Tool #20 offset compensation | |
| 1477 | 0 | mm | Z-axis, Tool #20 offset compensation | |
| 1478 | 0 | mm | A-axis, Tool #20 offset compensation | |
| 1479 | 0 | mm | B-axis, Tool #20 offset compensation | |
| 1480 | 0 | mm | C-axis, Tool #20 offset compensation | |
| 1481 | 0 | mm | Tool #21 radius compensation | |
| 1482 | 0 | mm | X-axis, Tool #21 offset compensation | |
| 1483 | 0 | mm | Y-axis, Tool #21 offset compensation | |
| 1484 | 0 | mm | Z-axis, Tool #21 offset compensation | |
| 1485 | 0 | mm | A-axis, Tool #21 offset compensation | |
| 1486 | 0 | mm | B-axis, Tool #21 offset compensation | |
| 1487 | 0 | mm | C-axis, Tool #21 offset compensation | |
| 1488 | 0 | mm | Tool #22 radius compensation | |
| 1489 | 0 | mm | X-axis, Tool #22 offset compensation | |
| 1490 | 0 | mm | Y-axis, Tool #22 offset compensation | |
| 1491 | 0 | mm | Z-axis, Tool #22 offset compensation | |
| 1492 | 0 | mm | A-axis, Tool #22 offset compensation | |
| 1493 | 0 | mm | B-axis, Tool #22 offset compensation | |
| 1494 | 0 | mm | C-axis, Tool #22 offset compensation | |
| 1495 | 0 | mm | Tool #23 radius compensation | |
| 1496 | 0 | mm | X-axis, Tool #23 offset compensation | |
| 1497 | 0 | mm | Y-axis, Tool #23 offset compensation | |
| 1498 | 0 | mm | Z-axis, Tool #23 offset compensation | |
| 1499 | 0 | mm | A-axis, Tool #23 offset compensation | |
| 1500 | 0 | mm | B-axis, Tool #23 offset compensation | |
| 1501 | 0 | mm | C-axis, Tool #23 offset compensation | |
| 1502 | 0 | mm | Tool #24 radius compensation | |
| 1503 | 0 | mm | X-axis, Tool #24 offset compensation | |
| 1504 | 0 | mm | Y-axis, Tool #24 offset compensation | |
| 1505 | 0 | mm | Z-axis, Tool #24 offset compensation | |
| 1506 | 0 | mm | A-axis, Tool #24 offset compensation | |
| 1507 | 0 | mm | B-axis, Tool #24 offset compensation | |
| 1508 | 0 | mm | C-axis, Tool #24 offset compensation | |
| 1509 | 0 | mm | Tool #25 radius compensation | |
| 1510 | 0 | mm | X-axis, Tool #25 offset compensation | |
| 1511 | 0 | mm | Y-axis, Tool #25 offset compensation | |
| 1512 | 0 | mm | Z-axis, Tool #25 offset compensation | |
| 1513 | 0 | mm | A-axis, Tool #25 offset compensation | |
| 1514 | 0 | mm | B-axis, Tool #25 offset compensation | |
| 1515 | 0 | mm | C-axis, Tool #25 offset compensation | |
| 1516 | 0 | mm | Tool #26 radius compensation | |
| 1517 | 0 | mm | X-axis, Tool #26 offset compensation | |
| 1518 | 0 | mm | Y-axis, Tool #26 offset compensation | |
| 1519 | 0 | mm | Z-axis, Tool #26 offset compensation | |
| 1520 | 0 | mm | A-axis, Tool #26 offset compensation | |
| 1521 | 0 | mm | B-axis, Tool #26 offset compensation | |

| MCM No. | Factory Default Setting | Unit | Description | Setting |
|---------|-------------------------|------|--------------------------------------|---------|
| 1522 | 0 | mm | C-axis, Tool #26 offset compensation | |
| 1523 | 0 | mm | Tool #27 radius compensation | |
| 1524 | 0 | mm | X-axis, Tool #27 offset compensation | |
| 1525 | 0 | mm | Y-axis, Tool #27 offset compensation | |
| 1526 | 0 | mm | Z-axis, Tool #27 offset compensation | |
| 1527 | 0 | mm | A-axis, Tool #27 offset compensation | |
| 1528 | 0 | mm | B-axis, Tool #27 offset compensation | |
| 1529 | 0 | mm | C-axis, Tool #27 offset compensation | |
| 1530 | 0 | mm | Tool #28 radius compensation | |
| 1531 | 0 | mm | X-axis, Tool #28 offset compensation | |
| 1532 | 0 | mm | Y-axis, Tool #28 offset compensation | |
| 1533 | 0 | mm | Z-axis, Tool #28 offset compensation | |
| 1534 | 0 | mm | A-axis, Tool #28 offset compensation | |
| 1535 | 0 | mm | B-axis, Tool #28 offset compensation | |
| 1536 | 0 | mm | C-axis, Tool #28 offset compensation | |
| 1537 | 0 | mm | Tool #29 radius compensation | |
| 1538 | 0 | mm | X-axis, Tool #29 offset compensation | |
| 1539 | 0 | mm | Y-axis, Tool #29 offset compensation | |
| 1540 | 0 | mm | Z-axis, Tool #29 offset compensation | |
| 1541 | 0 | mm | A-axis, Tool #29 offset compensation | |
| 1542 | 0 | mm | B-axis, Tool #29 offset compensation | |
| 1543 | 0 | mm | C-axis, Tool #29 offset compensation | |
| 1544 | 0 | mm | Tool #30 radius compensation | |
| 1545 | 0 | mm | X-axis, Tool #30 offset compensation | |
| 1546 | 0 | mm | Y-axis, Tool #30 offset compensation | |
| 1547 | 0 | mm | Z-axis, Tool #30 offset compensation | |
| 1548 | 0 | mm | A-axis, Tool #30 offset compensation | |
| 1549 | 0 | mm | B-axis, Tool #30 offset compensation | |
| 1550 | 0 | mm | C-axis, Tool #30 offset compensation | |
| 1551 | 0 | mm | Tool #31 radius compensation | |
| 1552 | 0 | mm | X-axis, Tool #31 offset compensation | |
| 1553 | 0 | mm | Y-axis, Tool #31 offset compensation | |
| 1554 | 0 | mm | Z-axis, Tool #31 offset compensation | |
| 1555 | 0 | mm | A-axis, Tool #31 offset compensation | |
| 1556 | 0 | mm | B-axis, Tool #31 offset compensation | |
| 1557 | 0 | mm | C-axis, Tool #31 offset compensation | |
| 1558 | 0 | mm | Tool #32 radius compensation | |
| 1559 | 0 | mm | X-axis, Tool #32 offset compensation | |
| 1560 | 0 | mm | Y-axis, Tool #32 offset compensation | |
| 1561 | 0 | mm | Z-axis, Tool #32 offset compensation | |
| 1562 | 0 | mm | A-axis, Tool #32 offset compensation | |
| 1563 | 0 | mm | B-axis, Tool #32 offset compensation | |
| 1564 | 0 | mm | C-axis, Tool #32 offset compensation | |
| 1565 | 0 | mm | Tool #33 radius compensation | |
| 1566 | 0 | mm | X-axis, Tool #33 offset compensation | |
| 1567 | 0 | mm | Y-axis, Tool #33 offset compensation | |
| 1568 | 0 | mm | Z-axis, Tool #33 offset compensation | |
| 1569 | 0 | mm | A-axis, Tool #33 offset compensation | |
| 1570 | 0 | mm | B-axis, Tool #33 offset compensation | |
| 1571 | 0 | mm | C-axis, Tool #33 offset compensation | |
| 1572 | 0 | mm | Tool #34 radius compensation | |
| 1573 | 0 | mm | X-axis, Tool #34 offset compensation | |
| 1574 | 0 | mm | Y-axis, Tool #34 offset compensation | |

| MCM No. | Factory Default Setting | Unit | Description | Setting |
|---------|-------------------------|------|--------------------------------------|---------|
| 1575 | 0 | mm | Z-axis, Tool #34 offset compensation | |
| 1576 | 0 | mm | A-axis, Tool #34 offset compensation | |
| 1577 | 0 | mm | B-axis, Tool #34 offset compensation | |
| 1578 | 0 | mm | C-axis, Tool #34 offset compensation | |
| 1579 | 0 | mm | Tool #35 radius compensation | |
| 1580 | 0 | mm | X-axis, Tool #35 offset compensation | |
| 1581 | 0 | mm | Y-axis, Tool #35 offset compensation | |
| 1582 | 0 | mm | Z-axis, Tool #35 offset compensation | |
| 1583 | 0 | mm | A-axis, Tool #35 offset compensation | |
| 1584 | 0 | mm | B-axis, Tool #35 offset compensation | |
| 1585 | 0 | mm | C-axis, Tool #35 offset compensation | |
| 1586 | 0 | mm | Tool #36 radius compensation | |
| 1587 | 0 | mm | X-axis, Tool #36 offset compensation | |
| 1588 | 0 | mm | Y-axis, Tool #36 offset compensation | |
| 1589 | 0 | mm | Z-axis, Tool #36 offset compensation | |
| 1590 | 0 | mm | A-axis, Tool #36 offset compensation | |
| 1591 | 0 | mm | B-axis, Tool #36 offset compensation | |
| 1592 | 0 | mm | C-axis, Tool #36 offset compensation | |
| 1593 | 0 | mm | Tool #37 radius compensation | |
| 1594 | 0 | mm | X-axis, Tool #37 offset compensation | |
| 1595 | 0 | mm | Y-axis, Tool #37 offset compensation | |
| 1596 | 0 | mm | Z-axis, Tool #37 offset compensation | |
| 1597 | 0 | mm | A-axis, Tool #37 offset compensation | |
| 1598 | 0 | mm | B-axis, Tool #37 offset compensation | |
| 1599 | 0 | mm | C-axis, Tool #37 offset compensation | |
| 1600 | 0 | mm | Tool #38 radius compensation | |
| 1601 | 0 | mm | X-axis, Tool #38 offset compensation | |
| 1602 | 0 | mm | Y-axis, Tool #38 offset compensation | |
| 1603 | 0 | mm | Z-axis, Tool #38 offset compensation | |
| 1604 | 0 | mm | A-axis, Tool #38 offset compensation | |
| 1605 | 0 | mm | B-axis, Tool #38 offset compensation | |
| 1606 | 0 | mm | C-axis, Tool #38 offset compensation | |
| 1607 | 0 | mm | Tool #39 radius compensation | |
| 1608 | 0 | mm | X-axis, Tool #39 offset compensation | |
| 1609 | 0 | mm | Y-axis, Tool #39 offset compensation | |
| 1610 | 0 | mm | Z-axis, Tool #39 offset compensation | |
| 1611 | 0 | mm | A-axis, Tool #39 offset compensation | |
| 1612 | 0 | mm | B-axis, Tool #39 offset compensation | |
| 1613 | 0 | mm | C-axis, Tool #39 offset compensation | |
| 1614 | 0 | mm | Tool #40 radius compensation | |
| 1615 | 0 | mm | X-axis, Tool #40 offset compensation | |
| 1616 | 0 | mm | Y-axis, Tool #40 offset compensation | |
| 1617 | 0 | mm | Z-axis, Tool #40 offset compensation | |
| 1618 | 0 | mm | A-axis, Tool #40 offset compensation | |
| 1619 | 0 | mm | B-axis, Tool #40 offset compensation | |
| 1620 | 0 | mm | C-axis, Tool #40 offset compensation | |
| 1621 | 0 | mm | Tool #1 radius wear compensation | |
| 1622 | 0 | mm | X-axis, Tool #1 wear compensation | |
| 1623 | 0 | mm | Y-axis, Tool #1 wear compensation | |
| 1624 | 0 | mm | Z-axis, Tool #1 wear compensation | |
| 1625 | 0 | mm | A-axis, Tool #1 wear compensation | |
| 1626 | 0 | mm | B-axis, Tool #1 wear compensation | |
| 1627 | 0 | mm | C-axis, Tool #1 wear compensation | |

| MCM No. | Factory Default Setting | Unit | Description | Setting |
|---------|-------------------------|------|-----------------------------------|---------|
| 1628 | 0 | mm | Tool #2 radius wear compensation | |
| 1629 | 0 | mm | X-axis, Tool #2 wear compensation | |
| 1630 | 0 | mm | Y-axis, Tool #2 wear compensation | |
| 1631 | 0 | mm | Z-axis, Tool #2 wear compensation | |
| 1632 | 0 | mm | A-axis, Tool #2 wear compensation | |
| 1633 | 0 | mm | B-axis, Tool #2 wear compensation | |
| 1634 | 0 | mm | C-axis, Tool #2 wear compensation | |
| 1635 | 0 | mm | Tool #3 radius wear compensation | |
| 1636 | 0 | mm | X-axis, Tool #3 wear compensation | |
| 1637 | 0 | mm | Y-axis, Tool #3 wear compensation | |
| 1638 | 0 | mm | Z-axis, Tool #3 wear compensation | |
| 1639 | 0 | mm | A-axis, Tool #3 wear compensation | |
| 1640 | 0 | mm | B-axis, Tool #3 wear compensation | |
| 1641 | 0 | mm | C-axis, Tool #3 wear compensation | |
| 1642 | 0 | mm | Tool #4 radius wear compensation | |
| 1643 | 0 | mm | X-axis, Tool #4 wear compensation | |
| 1644 | 0 | mm | Y-axis, Tool #4 wear compensation | |
| 1645 | 0 | mm | Z-axis, Tool #4 wear compensation | |
| 1646 | 0 | mm | A-axis, Tool #4 wear compensation | |
| 1647 | 0 | mm | B-axis, Tool #4 wear compensation | |
| 1648 | 0 | mm | C-axis, Tool #4 wear compensation | |
| 1649 | 0 | mm | Tool #5 radius wear compensation | |
| 1650 | 0 | mm | X-axis, Tool #5 wear compensation | |
| 1651 | 0 | mm | Y-axis, Tool #5 wear compensation | |
| 1652 | 0 | mm | Z-axis, Tool #5 wear compensation | |
| 1653 | 0 | mm | A-axis, Tool #5 wear compensation | |
| 1654 | 0 | mm | B-axis, Tool #5 wear compensation | |
| 1655 | 0 | mm | C-axis, Tool #5 wear compensation | |
| 1656 | 0 | mm | Tool #6 radius wear compensation | |
| 1657 | 0 | mm | X-axis, Tool #6 wear compensation | |
| 1658 | 0 | mm | Y-axis, Tool #6 wear compensation | |
| 1659 | 0 | mm | Z-axis, Tool #6 wear compensation | |
| 1660 | 0 | mm | A-axis, Tool #6 wear compensation | |
| 1661 | 0 | mm | B-axis, Tool #6 wear compensation | |
| 1662 | 0 | mm | C-axis, Tool #6 wear compensation | |
| 1663 | 0 | mm | Tool #7 radius wear compensation | |
| 1664 | 0 | mm | X-axis, Tool #7 wear compensation | |
| 1665 | 0 | mm | Y-axis, Tool #7 wear compensation | |
| 1666 | 0 | mm | Z-axis, Tool #7 wear compensation | |
| 1667 | 0 | mm | A-axis, Tool #7 wear compensation | |
| 1668 | 0 | mm | B-axis, Tool #7 wear compensation | |
| 1669 | 0 | mm | C-axis, Tool #7 wear compensation | |
| 1670 | 0 | mm | Tool #8 radius wear compensation | |
| 1671 | 0 | mm | X-axis, Tool #8 wear compensation | |
| 1672 | 0 | mm | Y-axis, Tool #8 wear compensation | |
| 1673 | 0 | mm | Z-axis, Tool #8 wear compensation | |
| 1674 | 0 | mm | A-axis, Tool #8 wear compensation | |
| 1675 | 0 | mm | B-axis, Tool #8 wear compensation | |
| 1676 | 0 | mm | C-axis, Tool #8 wear compensation | |
| 1677 | 0 | mm | Tool #9 radius wear compensation | |
| 1678 | 0 | mm | X-axis, Tool #9 wear compensation | |
| 1679 | 0 | mm | Y-axis, Tool #9 wear compensation | |
| 1680 | 0 | mm | Z-axis, Tool #9 wear compensation | |

| MCM No. | Factory Default Setting | Unit | Description | Setting |
|---------|-------------------------|------|------------------------------------|---------|
| 1681 | 0 | mm | A-axis, Tool #9 wear compensation | |
| 1682 | 0 | mm | B-axis, Tool #9 wear compensation | |
| 1683 | 0 | mm | C-axis, Tool #9 wear compensation | |
| 1684 | 0 | mm | Tool #10 radius wear compensation | |
| 1685 | 0 | mm | X-axis, Tool #10 wear compensation | |
| 1686 | 0 | mm | Y-axis, Tool #10 wear compensation | |
| 1687 | 0 | mm | Z-axis, Tool #10 wear compensation | |
| 1688 | 0 | mm | A-axis, Tool #10 wear compensation | |
| 1689 | 0 | mm | B-axis, Tool #10 wear compensation | |
| 1690 | 0 | mm | C-axis, Tool #10 wear compensation | |
| 1691 | 0 | mm | Tool #11 radius wear compensation | |
| 1692 | 0 | mm | X-axis, Tool #11 wear compensation | |
| 1693 | 0 | mm | Y-axis, Tool #11 wear compensation | |
| 1694 | 0 | mm | Z-axis, Tool #11 wear compensation | |
| 1695 | 0 | mm | A-axis, Tool #11 wear compensation | |
| 1696 | 0 | mm | B-axis, Tool #11 wear compensation | |
| 1697 | 0 | mm | C-axis, Tool #11 wear compensation | |
| 1698 | 0 | mm | Tool #12 radius wear compensation | |
| 1699 | 0 | mm | X-axis, Tool #12 wear compensation | |
| 1700 | 0 | mm | Y-axis, Tool #12 wear compensation | |
| 1701 | 0 | mm | Z-axis, Tool #12 wear compensation | |
| 1702 | 0 | mm | A-axis, Tool #12 wear compensation | |
| 1703 | 0 | mm | B-axis, Tool #12 wear compensation | |
| 1704 | 0 | mm | C-axis, Tool #12 wear compensation | |
| 1705 | 0 | mm | Tool #13 radius wear compensation | |
| 1706 | 0 | mm | X-axis, Tool #13 wear compensation | |
| 1707 | 0 | mm | Y-axis, Tool #13 wear compensation | |
| 1708 | 0 | mm | Z-axis, Tool #13 wear compensation | |
| 1709 | 0 | mm | A-axis, Tool #13 wear compensation | |
| 1710 | 0 | mm | B-axis, Tool #13 wear compensation | |
| 1711 | 0 | mm | C-axis, Tool #13 wear compensation | |
| 1712 | 0 | mm | Tool #14 radius wear compensation | |
| 1713 | 0 | mm | X-axis, Tool #14 wear compensation | |
| 1714 | 0 | mm | Y-axis, Tool #14 wear compensation | |
| 1715 | 0 | mm | Z-axis, Tool #14 wear compensation | |
| 1716 | 0 | mm | A-axis, Tool #14 wear compensation | |
| 1717 | 0 | mm | B-axis, Tool #14 wear compensation | |
| 1718 | 0 | mm | C-axis, Tool #14 wear compensation | |
| 1719 | 0 | mm | Tool #15 radius wear compensation | |
| 1720 | 0 | mm | X-axis, Tool #15 wear compensation | |
| 1721 | 0 | mm | Y-axis, Tool #15 wear compensation | |
| 1722 | 0 | mm | Z-axis, Tool #15 wear compensation | |
| 1723 | 0 | mm | A-axis, Tool #15 wear compensation | |
| 1724 | 0 | mm | B-axis, Tool #15 wear compensation | |
| 1725 | 0 | mm | C-axis, Tool #15 wear compensation | |
| 1726 | 0 | mm | Tool #16 radius wear compensation | |
| 1727 | 0 | mm | X-axis, Tool #16 wear compensation | |
| 1728 | 0 | mm | Y-axis, Tool #16 wear compensation | |
| 1729 | 0 | mm | Z-axis, Tool #16 wear compensation | |
| 1730 | 0 | mm | A-axis, Tool #16 wear compensation | |
| 1731 | 0 | mm | B-axis, Tool #16 wear compensation | |
| 1732 | 0 | mm | C-axis, Tool #16 wear compensation | |
| 1733 | 0 | mm | Tool #17 radius wear compensation | |

| MCM No. | Factory Default Setting | Unit | Description | Setting |
|---------|-------------------------|------|------------------------------------|---------|
| 1734 | 0 | mm | X-axis, Tool #17 wear compensation | |
| 1735 | 0 | mm | Y-axis, Tool #17 wear compensation | |
| 1736 | 0 | mm | Z-axis, Tool #17 wear compensation | |
| 1737 | 0 | mm | A-axis, Tool #17 wear compensation | |
| 1738 | 0 | mm | B-axis, Tool #17 wear compensation | |
| 1739 | 0 | mm | C-axis, Tool #17 wear compensation | |
| 1740 | 0 | mm | Tool #18 radius wear compensation | |
| 1741 | 0 | mm | X-axis, Tool #18 wear compensation | |
| 1742 | 0 | mm | Y-axis, Tool #18 wear compensation | |
| 1743 | 0 | mm | Z-axis, Tool #18 wear compensation | |
| 1744 | 0 | mm | A-axis, Tool #18 wear compensation | |
| 1745 | 0 | mm | B-axis, Tool #18 wear compensation | |
| 1746 | 0 | mm | C-axis, Tool #18 wear compensation | |
| 1747 | 0 | mm | Tool #19 radius wear compensation | |
| 1748 | 0 | mm | X-axis, Tool #19 wear compensation | |
| 1749 | 0 | mm | Y-axis, Tool #19 wear compensation | |
| 1750 | 0 | mm | Z-axis, Tool #19 wear compensation | |
| 1751 | 0 | mm | A-axis, Tool #19 wear compensation | |
| 1752 | 0 | mm | B-axis, Tool #19 wear compensation | |
| 1753 | 0 | mm | C-axis, Tool #19 wear compensation | |
| 1754 | 0 | mm | Tool #20 radius wear compensation | |
| 1755 | 0 | mm | X-axis, Tool #20 wear compensation | |
| 1756 | 0 | mm | Y-axis, Tool #20 wear compensation | |
| 1757 | 0 | mm | Z-axis, Tool #20 wear compensation | |
| 1758 | 0 | mm | A-axis, Tool #20 wear compensation | |
| 1759 | 0 | mm | B-axis, Tool #20 wear compensation | |
| 1760 | 0 | mm | C-axis, Tool #20 wear compensation | |
| 1761 | 0 | mm | Tool #21 radius wear compensation | |
| 1762 | 0 | mm | X-axis, Tool #21 wear compensation | |
| 1763 | 0 | mm | Y-axis, Tool #21 wear compensation | |
| 1764 | 0 | mm | Z-axis, Tool #21 wear compensation | |
| 1765 | 0 | mm | A-axis, Tool #21 wear compensation | |
| 1766 | 0 | mm | B-axis, Tool #21 wear compensation | |
| 1767 | 0 | mm | C-axis, Tool #21 wear compensation | |
| 1768 | 0 | mm | Tool #22 radius wear compensation | |
| 1769 | 0 | mm | X-axis, Tool #22 wear compensation | |
| 1770 | 0 | mm | Y-axis, Tool #22 wear compensation | |
| 1771 | 0 | mm | Z-axis, Tool #22 wear compensation | |
| 1772 | 0 | mm | A-axis, Tool #22 wear compensation | |
| 1773 | 0 | mm | B-axis, Tool #22 wear compensation | |
| 1774 | 0 | mm | C-axis, Tool #22 wear compensation | |
| 1775 | 0 | mm | Tool #23 radius wear compensation | |
| 1776 | 0 | mm | X-axis, Tool #23 wear compensation | |
| 1777 | 0 | mm | Y-axis, Tool #23 wear compensation | |
| 1778 | 0 | mm | Z-axis, Tool #23 wear compensation | |
| 1779 | 0 | mm | A-axis, Tool #23 wear compensation | |
| 1780 | 0 | mm | B-axis, Tool #23 wear compensation | |
| 1781 | 0 | mm | C-axis, Tool #23 wear compensation | |
| 1782 | 0 | mm | Tool #24 radius wear compensation | |
| 1783 | 0 | mm | X-axis, Tool #24 wear compensation | |
| 1784 | 0 | mm | Y-axis, Tool #24 wear compensation | |
| 1785 | 0 | mm | Z-axis, Tool #24 wear compensation | |
| 1786 | 0 | mm | A-axis, Tool #24 wear compensation | |

| MCM No. | Factory Default Setting | Unit | Description | Setting |
|---------|-------------------------|------|------------------------------------|---------|
| 1787 | 0 | mm | B-axis, Tool #24 wear compensation | |
| 1788 | 0 | mm | C-axis, Tool #24 wear compensation | |
| 1789 | 0 | mm | Tool #25 radius wear compensation | |
| 1790 | 0 | mm | X-axis, Tool #25 wear compensation | |
| 1791 | 0 | mm | Y-axis, Tool #25 wear compensation | |
| 1792 | 0 | mm | Z-axis, Tool #25 wear compensation | |
| 1793 | 0 | mm | A-axis, Tool #25 wear compensation | |
| 1794 | 0 | mm | B-axis, Tool #25 wear compensation | |
| 1795 | 0 | mm | C-axis, Tool #25 wear compensation | |
| 1796 | 0 | mm | Tool #26 radius wear compensation | |
| 1797 | 0 | mm | X-axis, Tool #26 wear compensation | |
| 1798 | 0 | mm | Y-axis, Tool #26 wear compensation | |
| 1799 | 0 | mm | Z-axis, Tool #26 wear compensation | |
| 1800 | 0 | mm | A-axis, Tool #26 wear compensation | |
| 1801 | 0 | mm | B-axis, Tool #26 wear compensation | |
| 1802 | 0 | mm | C-axis, Tool #26 wear compensation | |
| 1803 | 0 | mm | Tool #27 radius wear compensation | |
| 1804 | 0 | mm | X-axis, Tool #27 wear compensation | |
| 1805 | 0 | mm | Y-axis, Tool #27 wear compensation | |
| 1806 | 0 | mm | Z-axis, Tool #27 wear compensation | |
| 1807 | 0 | mm | A-axis, Tool #27 wear compensation | |
| 1808 | 0 | mm | B-axis, Tool #27 wear compensation | |
| 1809 | 0 | mm | C-axis, Tool #27 wear compensation | |
| 1810 | 0 | mm | Tool #28 radius wear compensation | |
| 1811 | 0 | mm | X-axis, Tool #28 wear compensation | |
| 1812 | 0 | mm | Y-axis, Tool #28 wear compensation | |
| 1813 | 0 | mm | Z-axis, Tool #28 wear compensation | |
| 1814 | 0 | mm | A-axis, Tool #28 wear compensation | |
| 1815 | 0 | mm | B-axis, Tool #28 wear compensation | |
| 1816 | 0 | mm | C-axis, Tool #28 wear compensation | |
| 1817 | 0 | mm | Tool #29 radius wear compensation | |
| 1818 | 0 | mm | X-axis, Tool #29 wear compensation | |
| 1819 | 0 | mm | Y-axis, Tool #29 wear compensation | |
| 1820 | 0 | mm | Z-axis, Tool #29 wear compensation | |
| 1821 | 0 | mm | A-axis, Tool #29 wear compensation | |
| 1822 | 0 | mm | B-axis, Tool #29 wear compensation | |
| 1823 | 0 | mm | C-axis, Tool #29 wear compensation | |
| 1824 | 0 | mm | Tool #30 radius wear compensation | |
| 1825 | 0 | mm | X-axis, Tool #30 wear compensation | |
| 1826 | 0 | mm | Y-axis, Tool #30 wear compensation | |
| 1827 | 0 | mm | Z-axis, Tool #30 wear compensation | |
| 1828 | 0 | mm | A-axis, Tool #30 wear compensation | |
| 1829 | 0 | mm | B-axis, Tool #30 wear compensation | |
| 1830 | 0 | mm | C-axis, Tool #30 wear compensation | |
| 1831 | 0 | mm | Tool #31 radius wear compensation | |
| 1832 | 0 | mm | X-axis, Tool #31 wear compensation | |
| 1833 | 0 | mm | Y-axis, Tool #31 wear compensation | |
| 1834 | 0 | mm | Z-axis, Tool #31 wear compensation | |
| 1835 | 0 | mm | A-axis, Tool #31 wear compensation | |
| 1836 | 0 | mm | B-axis, Tool #31 wear compensation | |
| 1837 | 0 | mm | C-axis, Tool #31 wear compensation | |
| 1838 | 0 | mm | Tool #32 radius wear compensation | |
| 1839 | 0 | mm | X-axis, Tool #32 wear compensation | |

| MCM No. | Factory Default Setting | Unit | Description | Setting |
|---------|-------------------------|------|------------------------------------|---------|
| 1840 | 0 | mm | Y-axis, Tool #32 wear compensation | |
| 1841 | 0 | mm | Z-axis, Tool #32 wear compensation | |
| 1842 | 0 | mm | A-axis, Tool #32 wear compensation | |
| 1843 | 0 | mm | B-axis, Tool #32 wear compensation | |
| 1844 | 0 | mm | C-axis, Tool #32 wear compensation | |
| 1845 | 0 | mm | Tool #33 radius wear compensation | |
| 1846 | 0 | mm | X-axis, Tool #33 wear compensation | |
| 1847 | 0 | mm | Y-axis, Tool #33 wear compensation | |
| 1848 | 0 | mm | Z-axis, Tool #33 wear compensation | |
| 1849 | 0 | mm | A-axis, Tool #33 wear compensation | |
| 1850 | 0 | mm | B-axis, Tool #33 wear compensation | |
| 1851 | 0 | mm | C-axis, Tool #33 wear compensation | |
| 1852 | 0 | mm | Tool #34 radius wear compensation | |
| 1853 | 0 | mm | X-axis, Tool #34 wear compensation | |
| 1854 | 0 | mm | Y-axis, Tool #34 wear compensation | |
| 1855 | 0 | mm | Z-axis, Tool #34 wear compensation | |
| 1856 | 0 | mm | A-axis, Tool #34 wear compensation | |
| 1857 | 0 | mm | B-axis, Tool #34 wear compensation | |
| 1858 | 0 | mm | C-axis, Tool #34 wear compensation | |
| 1859 | 0 | mm | Tool #35 radius wear compensation | |
| 1860 | 0 | mm | X-axis, Tool #35 wear compensation | |
| 1861 | 0 | mm | Y-axis, Tool #35 wear compensation | |
| 1862 | 0 | mm | Z-axis, Tool #35 wear compensation | |
| 1863 | 0 | mm | A-axis, Tool #35 wear compensation | |
| 1864 | 0 | mm | B-axis, Tool #35 wear compensation | |
| 1865 | 0 | mm | C-axis, Tool #35 wear compensation | |
| 1866 | 0 | mm | Tool #36 radius wear compensation | |
| 1867 | 0 | mm | X-axis, Tool #36 wear compensation | |
| 1868 | 0 | mm | Y-axis, Tool #36 wear compensation | |
| 1869 | 0 | mm | Z-axis, Tool #36 wear compensation | |
| 1870 | 0 | mm | A-axis, Tool #36 wear compensation | |
| 1871 | 0 | mm | B-axis, Tool #36 wear compensation | |
| 1872 | 0 | mm | C-axis, Tool #36 wear compensation | |
| 1873 | 0 | mm | Tool #37 radius wear compensation | |
| 1874 | 0 | mm | X-axis, Tool #37 wear compensation | |
| 1875 | 0 | mm | Y-axis, Tool #37 wear compensation | |
| 1876 | 0 | mm | Z-axis, Tool #37 wear compensation | |
| 1877 | 0 | mm | A-axis, Tool #37 wear compensation | |
| 1878 | 0 | mm | B-axis, Tool #37 wear compensation | |
| 1879 | 0 | mm | C-axis, Tool #37 wear compensation | |
| 1880 | 0 | mm | Tool #38 radius wear compensation | |
| 1881 | 0 | mm | X-axis, Tool #38 wear compensation | |
| 1882 | 0 | mm | Y-axis, Tool #38 wear compensation | |
| 1883 | 0 | mm | Z-axis, Tool #38 wear compensation | |
| 1884 | 0 | mm | A-axis, Tool #38 wear compensation | |
| 1885 | 0 | mm | B-axis, Tool #38 wear compensation | |
| 1886 | 0 | mm | C-axis, Tool #38 wear compensation | |
| 1887 | 0 | mm | Tool #39 radius wear compensation | |
| 1888 | 0 | mm | X-axis, Tool #39 wear compensation | |
| 1889 | 0 | mm | Y-axis, Tool #39 wear compensation | |
| 1890 | 0 | mm | Z-axis, Tool #39 wear compensation | |
| 1891 | 0 | mm | A-axis, Tool #39 wear compensation | |
| 1892 | 0 | mm | B-axis, Tool #39 wear compensation | |

| MCM No. | Factory Default Setting | Unit | Description | Setting |
|---------|-------------------------|------|------------------------------------|---------|
| 1893 | 0 | mm | C-axis, Tool #39 wear compensation | |
| 1894 | 0 | mm | Tool #40 radius wear compensation | |
| 1895 | 0 | mm | X-axis, Tool #40 wear compensation | |
| 1896 | 0 | mm | Y-axis, Tool #40 wear compensation | |
| 1897 | 0 | mm | Z-axis, Tool #40 wear compensation | |
| 1898 | 0 | mm | A-axis, Tool #40 wear compensation | |
| 1899 | 0 | mm | B-axis, Tool #40 wear compensation | |
| 1900 | 0 | mm | C-axis, Tool #40 wear compensation | |
| 1901 | | | Tool-tip #1 radius compensation | |
| 1902 | | | Tool-tip #2 radius compensation | |
| 1903 | | | Tool-tip #3 radius compensation | |
| 1904 | | | Tool-tip #4 radius compensation | |
| 1905 | | | Tool-tip #5 radius compensation | |
| 1906 | | | Tool-tip #6 radius compensation | |
| 1907 | | | Tool-tip #7 radius compensation | |
| 1908 | | | Tool-tip #8 radius compensation | |
| 1909 | | | Tool-tip #9 radius compensation | |
| 1910 | | | Tool-tip #10 radius compensation | |
| 1911 | | | Tool-tip #11 radius compensation | |
| 1912 | | | Tool-tip #12 radius compensation | |
| 1913 | | | Tool-tip #13 radius compensation | |
| 1914 | | | Tool-tip #14 radius compensation | |
| 1915 | | | Tool-tip #15 radius compensation | |
| 1916 | | | Tool-tip #16 radius compensation | |
| 1917 | | | Tool-tip #17 radius compensation | |
| 1918 | | | Tool-tip #18 radius compensation | |
| 1919 | | | Tool-tip #19 radius compensation | |
| 1920 | | | Tool-tip #20 radius compensation | |
| 1921 | | | Tool-tip #21 radius compensation | |
| 1922 | | | Tool-tip #22 radius compensation | |
| 1923 | | | Tool-tip #23 radius compensation | |
| 1924 | | | Tool-tip #24 radius compensation | |
| 1925 | | | Tool-tip #25 radius compensation | |
| 1926 | | | Tool-tip #26 radius compensation | |
| 1927 | | | Tool-tip #27 radius compensation | |
| 1928 | | | Tool-tip #28 radius compensation | |
| 1929 | | | Tool-tip #29 radius compensation | |
| 1930 | | | Tool-tip #30 radius compensation | |
| 1931 | | | Tool-tip #31 radius compensation | |
| 1932 | | | Tool-tip #32 radius compensation | |
| 1933 | | | Tool-tip #33 radius compensation | |
| 1934 | | | Tool-tip #34 radius compensation | |
| 1935 | | | Tool-tip #35 radius compensation | |
| 1936 | | | Tool-tip #36 radius compensation | |
| 1937 | | | Tool-tip #37 radius compensation | |
| 1938 | | | Tool-tip #38 radius compensation | |
| 1939 | | | Tool-tip #39 radius compensation | |
| 1940 | | | Tool-tip #40 radius compensation | |

PS: Press PAGE↑ or PAGE↓ once will change twelve items.

7.1 Description of MCM Machine Constants

The decimal format for MCM data in this section is based on 4/3 format.

MCM #1~#36 are for G54~G59 work coordinates data. The setting value is the distance between the origin of each work coordinate system and the machine HOME position.

All input data have the same format and unit as shown below:

1. G54 (1st) Work Coordinate, X-axis.
 2. G54 (1st) Work Coordinate, Y-axis.
 3. G54 (1st) Work Coordinate, Z-axis.
 4. G54 (1st) Work Coordinate, A-axis.
 5. G54 (1st) Work Coordinate, B-axis.
 6. G54 (1st) Work Coordinate, C-axis.
 7. G54 (1st) Work Coordinate, U-axis.
 8. G54 (1st) Work Coordinate, V-axis.
 9. G54 (1st) Work Coordinate, W-axis.
- Format : □.□□□ , Unit: mm (Default=0.000)

MCM# 10~20 System Reserved !

21. G55 (2nd) Work Coordinate, X-axis.
 22. G55 (2nd) Work Coordinate, Y-axis.
 23. G55 (2nd) Work Coordinate, Z-axis.
 24. G55 (2nd) Work Coordinate, A-axis.
 25. G55 (2nd) Work Coordinate, B-axis.
 26. G55 (2nd) Work Coordinate, C-axis.
 27. G55 (2nd) Work Coordinate, U-axis.
 28. G55 (2nd) Work Coordinate, V-axis.
 29. G55 (2nd) Work Coordinate, W-axis.
- Format : □.□□□ , Unit: mm (Default=0.000)

MCM# 30~40 System Reserved !

41. G56 (3rd) Work Coordinate, X-axis.
 42. G56 (3rd) Work Coordinate, Y-axis.
 43. G56 (3rd) Work Coordinate, Z-axis.
 44. G56 (3rd) Work Coordinate, A-axis.
 45. G56 (3rd) Work Coordinate, B-axis.
 46. G56 (3rd) Work Coordinate, C-axis.
 47. G56 (3rd) Work Coordinate, U-axis.
 48. G56 (3rd) Work Coordinate, V-axis.
 49. G56 (3rd) Work Coordinate, W-axis.
- Format : □.□□□ , Unit: mm (Default=0.000)

MCM# 50~60 System Reserved !

MCM# 61~69 G57 (4th) Work Coordinate.

MCM# 70~80 System Reserved !

MCM# 81~89 G58 (5th) Work Coordinate.
 MCM# 90~100 System Reserved !

MCM# 101~109 G59 (6th) Work Coordinate.
 MCM# 110~120 System Reserved !

MCM Parameters 121~160 are used for setting the coordinates of the reference point.
Its value is the mechanical coordinates of the reference point relative to the mechanical origin.

121. G28 1st Reference Point Data, X-axis.
 122. G28 1st Reference Point Data, Y-axis.
 123. G28 1st Reference Point Data, Z-axis.
 124. G28 1st Reference Point Data, A-axis.
 125. G28 1st Reference Point Data, B-axis.
 126. G28 1st Reference Point Data, C-axis.
 127. G28 1st Reference Point Data, U-axis.
 128. G28 1st Reference Point Data, V-axis.
 129. G28 1st Reference Point Data, W-axis.
 Format : □.□□□ , Unit: mm (Default=0.000)

MCM# 130~140 System Reserved !

141. G30 2st Reference Point Data, X-axis.
 142. G30 2st Reference Point Data, Y-axis.
 143. G30 2st Reference Point Data, Z-axis.
 144. G30 2st Reference Point Data, A-axis.
 145. G30 2st Reference Point Data, B-axis.
 146. G30 2st Reference Point Data, C-axis.
 147. G30 2st Reference Point Data, U-axis.
 148. G30 2st Reference Point Data, V-axis.
 149. G30 2st Reference Point Data, W-axis.
 Format : □.□□□ , Unit: mm (Default=0.000)

MCM# 150~160 System Reserved !

161. Backlash Compensation (G01), X-axis.
 162. Backlash Compensation (G01), Y-axis.
 163. Backlash Compensation (G01), Z-axis.
 164. Backlash Compensation (G01), A-axis.
 165. Backlash Compensation (G01), B-axis.
 166. Backlash Compensation (G01), C-axis.
 167. Backlash Compensation (G01), U-axis.
 168. Backlash Compensation (G01), V-axis.
 169. Backlash Compensation (G01), W-axis.
 Format : □.□□□ , Unit: pulse (Default=0) Range:0~9.9999

MCM# 170~180 System Reserved !

- 181. Backlash Compensation (G00), X-axis.
 - 182. Backlash Compensation (G00), Y-axis.
 - 183. Backlash Compensation (G00), Z-axis.
 - 184. Backlash Compensation (G00), A-axis.
 - 185. Backlash Compensation (G00), B-axis.
 - 186. Backlash Compensation (G00), C-axis.
 - 187. Backlash Compensation (G00), U-axis.
 - 188. Backlash Compensation (G00), V-axis.
 - 189. Backlash Compensation (G00), W-axis.
- Format : □.□□□ , Unit: pulse (Default=0) Range:0~9.9999

MCM# 170~200 System Reserved !

- 201. Jog Speed, X-axis.
 - 202. Jog Speed, Y-axis.
 - 203. Jog Speed, Z-axis.
 - 204. Jog Speed, A-axis.
 - 205. Jog Speed, B-axis.
 - 206. Jog Speed, C-axis.
 - 207. Jog Speed, U-axis.
 - 208. Jog Speed, V-axis.
 - 209. Jog Speed, W-axis.
- Format : □.□□□ , Unit: mm/min (Default=1000)

MCM# 210~220 System Reserved !

- 221. Traverse Speed Limit, X-axis.
 - 222. Traverse Speed Limit, Y-axis.
 - 223. Traverse Speed Limit, Z-axis.
 - 224. Traverse Speed Limit, A-axis.
 - 225. Traverse Speed Limit, B-axis.
 - 226. Traverse Speed Limit, C-axis.
 - 227. Traverse Speed Limit, U-axis.
 - 228. Traverse Speed Limit, V-axis.
 - 229. Traverse Speed Limit, W-axis.
- Format : □□□□□ , Unit: mm/min (Default=10000)
- Note : The format is only for integer.

The traverse speed limit can be calculated from the following equation:

$$F_{max} = 0.95 * RPM * Pitch * GR$$

- RPM : The ratio. rpm of servo motor
- Pitch : The pitch of the ball-screw
- GR : Gear ratio of ball-screw/motor

Ex: Max. rpm = 3000 rpm for X-axis, Pitch = 5 mm/rev, Gear Ratio = 5/1
Fmax = 0.95 * 3000 * 5 / 5 = 2850 mm/min
Therefore, it is recommended to set MCM #148=2850.

MCM# 230~240 System Reserved !

- 241. Denominator of Machine Resolution, X-axis.
 - 242. Numerator of Machine Resolution, X-axis.
 - 243. Denominator of Machine Resolution, Y-axis.
 - 244. Numerator of Machine Resolution, Y-axis.
 - 245. Denominator of Machine Resolution, Z-axis.
 - 246. Numerator of Machine Resolution, Z-axis
 - 247. Denominator of Machine Resolution, A-axis.
 - 248. Numerator of Machine Resolution, A-axis
 - 249. Denominator of Machine Resolution, B-axis.
 - 250. Numerator of Machine Resolution, B-axis
 - 251. Denominator of Machine Resolution, C-axis.
 - 252. Numerator of Machine Resolution, C-axis
 - 253. Denominator of Machine Resolution, U-axis.
 - 254. Numerator of Machine Resolution, U-axis
 - 255. Denominator of Machine Resolution, V-axis.
 - 256. Numerator of Machine Resolution, V-axis
 - 257. Denominator of Machine Resolution, W-axis.
 - 258. Numerator of Machine Resolution, W-axis
- Format : □.□□□ , (Default=100)

Denominator (D) = pulses/rev for the encoder on motor.

Numerator (N) = pitch length (mm/rev) of the ball-screw.

Gear Ratio (GR) = Tooth No. on ball-screw / Tooth No. on motor.

Pulse Multiplication Factor (MF) = MCM #416~#469.

$$\text{Machine Resolution} = \frac{(\text{Pitch of Ball - screw})}{(\text{Encoder Pulse}) * (\text{MF})} * \frac{1}{\text{GR}}$$

Ex1: X-axis as linear axis (MCM #781=0), pitch = 5 mm = 5000 μm
Encoder = 2500 pulses, MCM #461 = 4, and GR = 5 (motor rotates 5 times while ball-screw rotates once)

$$\text{Machine resolution} = 5000 / (2500 \times 4) / 5 = 5000 / 50000 = 1/10 = 0.1 \mu\text{m/pulse}$$

Therefore, the setting value for MCM #118 (D) and #119 (N) can be set as or the same ratio of N/D such as. They are all correct.

(1) D=50000, N=5000 (2) D=10, N=1 (3) D=100, N=10

Ex2: Y-axis as rotating axis (MCM #782=1), Angle = 360.000 deg/circle
Encoder = 2500 pulses, MCM #161 = 4, and GR = 5 (motor rotates 5 times while ball-screw rotates once)

$$\text{Machine resolution} = 360000 / (2500 \times 4) / 5 = 360000 / 50000 = 36/5 = 72/10$$

Therefore, the setting value for MCM #120 (D) and #121 (N) can be one of the three combinations. They are all correct.

(1) D=5, N=36 (2) D=10, N=72 (3) D=50000, N=360000

Ex 3 (Position Linear Axis):

The X-axis is an ordinary linear axis (MCM#781= 0) with the guide screw pitch = 5.000 mm.

When the motor rotates one turn, 10000 pulses will be generated.

Gear ratio is 5:1 (When the servo motor rotates 5 turns, the guide screw rotates 1 turn.)

$$\begin{aligned} \text{Resolution} &= \frac{5000}{10000} \times \frac{1}{5} \\ &= \frac{1}{10} \end{aligned}$$

X-axis resolution: denominator setting value (MCM#241)= 10

X-axis resolution: numerator setting value (MCM#242)= 1

Ex 4 (Position type rotational axis):

The Y-axis is a rotational axis (MCM#782 = 1). The angle for rotating 1 turn = 360.000 (degree)

One turn of the motor will generate 10000 pulses.

Gear ratio is 5:1 (When the servo motor rotates 5 turns, the Y-axis rotates 1 turn.)

$$\begin{aligned} \text{Resolution} &= \frac{360000}{10000} \times \frac{1}{5} \\ &= \frac{36}{5} \end{aligned}$$

Y-axis resolution: denominator setting value (MCM#243) = 5

Y-axis resolution: numerator setting value (MCM#244) = 36

Note 1: When the resolution <1/20, the motor may have the problem of not able to reach its maximum rotation speed.

**Note 2: When the resolution <1/100, the software travel limit should be within the following range:
-9999999 ~ 999999, otherwise an error message may occur which cannot be released.**

Ex: For MCM#241=400 and MCM#242=2, when the X-axis resolution is smaller than 1/100, the setting values of the software travel limit for the X-axis: Parameter 581 should be less than 9999999 and Parameter 601 should be greater than -999999.

MCM# 259~280 System Reserved !

281. Home Direction for Tool, X-axis.

- 282. Home Direction for Tool, Y-axis.
- 283. Home Direction for Tool, Z-axis.
- 284. Home Direction for Tool, A-axis.
- 285. Home Direction for Tool, B-axis.
- 286. Home Direction for Tool, C-axis.
- 287. Home Direction for Tool, U-axis.
- 288. Home Direction for Tool, V-axis.
- 289. Home Direction for Tool, W-axis.

Format : □ , (Default=0)

Setting = 0, Tool returning to HOME in the positive direction.

Setting = 1, Tool returning to HOME in the negative direction

MCM# 290~300 System Reserved !

- 301. Home Speed When Tool Going to Home, X-axis.
- 302. Home Speed When Tool Going to Home, Y-axis.
- 303. Home Speed When Tool Going to Home, Z-axis.
- 304. Home Speed When Tool Going to Home, A-axis.
- 305. Home Speed When Tool Going to Home, B-axis.
- 306. Home Speed When Tool Going to Home, C-axis.
- 307. Home Speed When Tool Going to Home, U-axis
- 308. Home Speed When Tool Going to Home, V-axis
- 309. Home Speed When Tool Going to Home, W-axis

Format : □□□□ , Unit: mm/min (Default=2500)

MCM# 310~320 System Reserved !

- 321. Home Grid Speed When Tool Going to Home, X-axis.
- 322. Home Grid Speed When Tool Going to Home, Y-axis.
- 323. Home Grid Speed When Tool Going to Home, Z-axis.
- 324. Home Grid Speed When Tool Going to Home, A-axis.
- 325. Home Grid Speed When Tool Going to Home, B-axis.
- 326. Home Grid Speed When Tool Going to Home, C-axis.
- 327. Home Grid Speed When Tool Going to Home, U-axis.
- 328. Home Grid Speed When Tool Going to Home, V-axis.
- 329. Home Grid Speed When Tool Going to Home, W-axis.

Format : □□□□ , Unit: mm/min (Default=40)

MCM# 330~340 System Reserved !

- 341. The direction that servo motor search the Grid when X-axis going back to HOME.
- 342. The direction that servo motor search the Grid when Y-axis going back to HOME.
- 343. The direction that servo motor search the Grid when Z-axis going back to HOME.
- 344. The direction that servo motor search the Grid when A-axis going back to HOME.
- 345. The direction that servo motor search the Grid when B-axis going back to HOME.
- 346. The direction that servo motor search the Grid when C-axis going back to HOME.
- 347. The direction that servo motor search the Grid when U-axis going back to HOME.
- 348. The direction that servo motor search the Grid when V-axis going back to HOME.

349. The direction that servo motor search the Grid when W-axis going back to HOME.

Format : □ , (Default=0)

EX:

When MCM#341= 0, the 2nd and 3rd direction is the same with 1st

MCM#341= 1, the 2nd is the same with 1st .

MCM#341= 128, the 2nd direction is opposite to 1st .

MCM#341= 256, the 2nd and 3rd direction is opposite to 1st .

Set the moving speed when the tool, after having touched the HOME limit switch, is searching for the encoder grid signal during HOME execution. HUST H6D/ H9D CNC has three (3) different speeds when you execute HOME function as shown by Fig 7.2.

Speed 1: The motor accelerates to Speed 1 and its maximum speed is determined by the settings of MCM #301 ~ #309, (X, Y, Z, A, B, C, U, V, W-axis) and the direction by MCM #281 ~ #289. When tool touches the home limit switch, it starts deceleration to a stop.

Speed 2: The motor accelerates again to speed 2 and its maximum speed is equal to 1/4 of Speed 1 and the direction is by MCM #341~#349. When tool starts leaving the home limit switch, it starts deceleration to a stop.

Speed 3: The motor accelerates to speed 3 and its maximum speed is determined by the settings of MCM #321~#329 and the direction by MCM #341~#349. Once the encoder grid index is found, motor decelerates to a stop. This is the HOME position.

Note that the length of the Home limit switch should be longer than the distance for the deceleration of Speed 1. Otherwise, serious error may result. The equation to calculate the length of the Home limit switch is

$$\text{Length of Home Limit Switch (mm)} \geq \frac{\text{FDCOM} * \text{ACC}}{60000}$$

FDCOM = Speed 1, in mm/min. (MCM #301~ #309)

ACC = Time for acceleration/deceleration, in ms. (MCM #505)

60000 = 60 seconds = 60 * 1000 milliseconds

When the C-bit C063=1 in PLC program, it commands the controller to do homing operation. Do homing operation for X-axis if R232=1, do Y-axis if R232=2, do Z-axis if R232=4, do A-axis if R232=8 and do four axes simultaneously if R232=15.

Ex: FDCOM = 3000.00 mm/min, and ACC = 100 ms

Length of Home Limit Switch = 3000 * 100 / 60000 = 5 mm

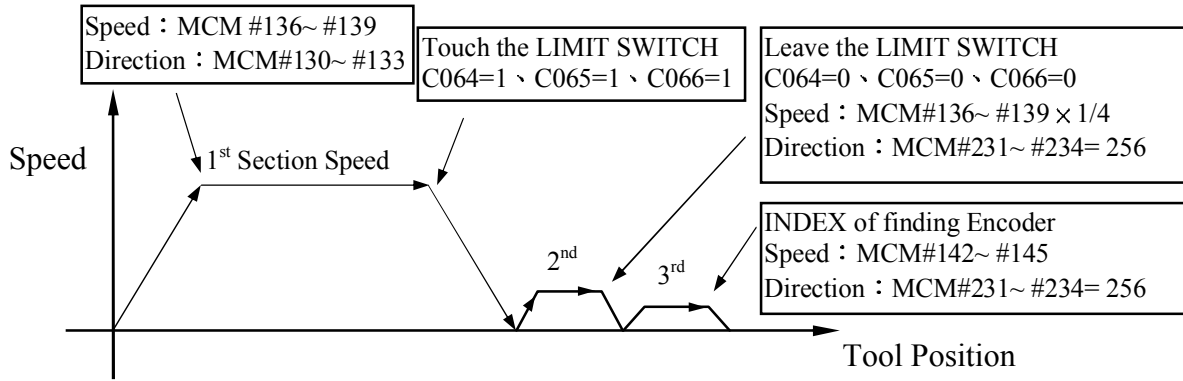

Fig 7.2 (A) Homing Speed and Direction of finding (GRID)

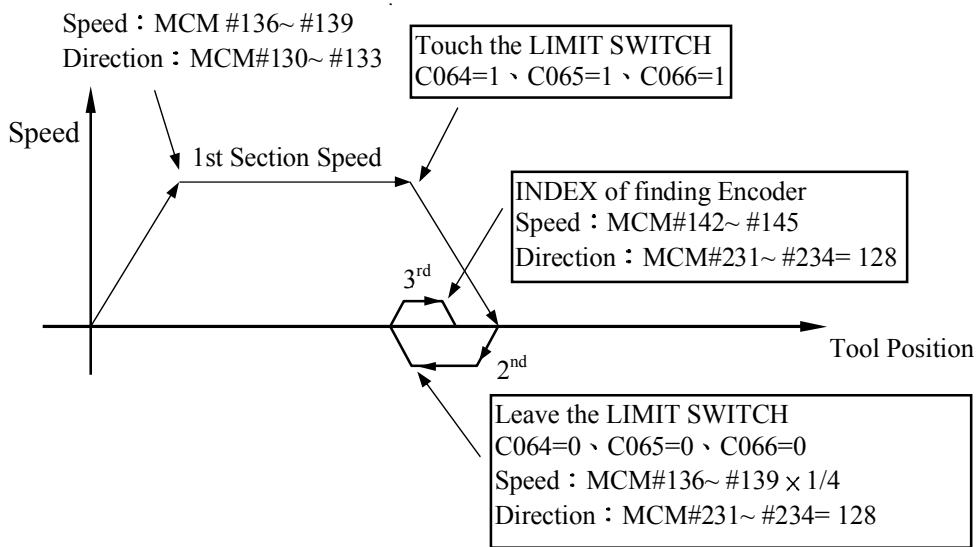

Fig 7.2 (B) Homing Speed and Direction of finding (GRID)

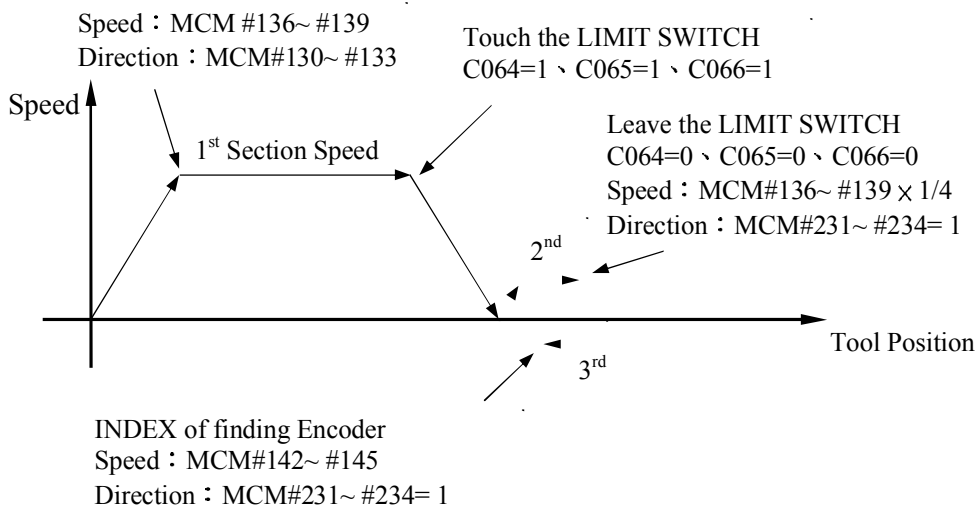

Fig 7-2 (C) Homing Speed and Direction of finding (GRID)

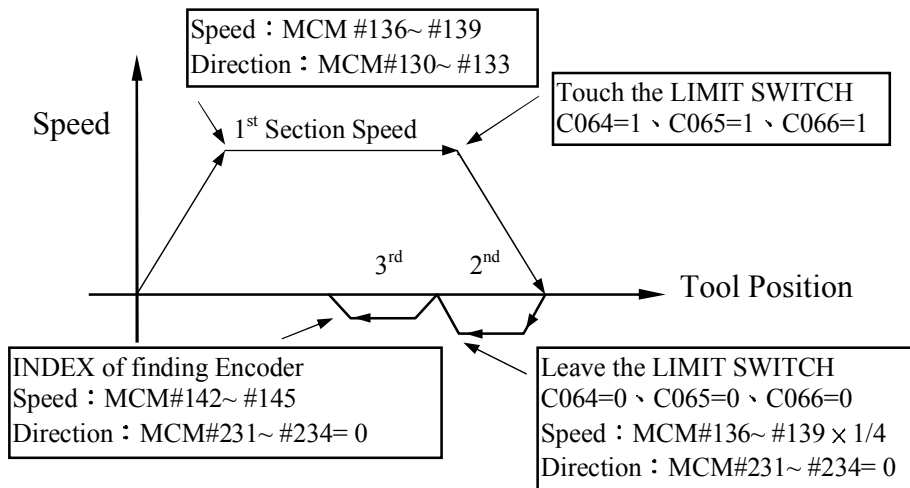

Fig 7-2 (D) Homing Speed and Direction of finding (GRID)

MCM# 350~360 System Reserved !

- 361. Setting the X-Home grid setting.
- 362. Setting the Y-Home grid setting.
- 363. Setting the Z-Home grid setting.
- 364. Setting the A-Home grid setting.
- 365. Setting the B-Home grid setting.
- 366. Setting the C-Home grid setting.
- 367. Setting the U-Home grid setting.
- 368. Setting the V-Home grid setting.
- 369. Setting the W-Home grid setting.

Format=□□□□.□□□ (Default=0.000), unit: mm

Leaving from the origin switch signal, deviating from the above set distance, and then you can start to execute the Homing process (third section) to locate the motor Grid signal.

MCM# 370~380 System Reserved !

- 381. Home-Shift Data, X-axis.
- 382. Home-Shift Data, Y-axis.
- 383. Home-Shift Data, Z-axis.
- 384. Home-Shift Data, A-axis.
- 385. Home-Shift Data, B-axis.
- 386. Home-Shift Data, C-axis.
- 387. Home-Shift Data, U-axis.
- 388. Home-Shift Data, V-axis.
- 389. Home-Shift Data, W-axis.

Format : □.□□□ , Unit: mm/min (Default=0.000)

Set the amount of coordinate shift for HOME location (or machine origin). With these settings, the machine coordinate will be shifted by the same amount when you execute "Home". If home shift data are zero for all axes, the machine

coordinate after "Home" operation will be zero also. Note that the work coordinate will be shifted by the same amount.

MCM# 390~400 System Reserved !

- 401. The distance that servo motor search the Grid when X-axis going back to HOME.
 - 402. The distance that servo motor search the Grid when Y-axis going back to HOME.
 - 403. The distance that servo motor search the Grid when Z-axis going back to HOME.
 - 404. The distance that servo motor search the Grid when A-axis going back to HOME.
 - 405. The distance that servo motor search the Grid when B-axis going back to HOME.
 - 406. The distance that servo motor search the Grid when C-axis going back to HOME.
 - 407. The distance that servo motor search the Grid when U-axis going back to HOME.
 - 408. The distance that servo motor search the Grid when V-axis going back to HOME.
 - 409. The distance that servo motor search the Grid when W-axis going back to HOME.
- Format=□□□□.□□□ (Default 10.000)

The distance's maximum when servo motor searching the Grid signal:

EX :

The servo motor of X-axis turns 3/4 round = 5.000 mm, MCM# 401 = 5.200

The servo motor of Y-axis turns 3/4 round = 5.000 mm, MCM# 402 = 5.200

The servo motor of Z-axis turns 3/4 round = 5.000 mm, MCM# 403 = 5.200

The servo motor of A-axis turns 3/4 round = 5.000 mm, MCM# 404 = 5.200

The servo motor of B-axis turns 3/4 round = 5.000 mm, MCM# 405 = 5.200

The servo motor of C-axis turns 3/4 round = 5.000 mm, MCM# 406 = 5.200

※ If it exceeds the range and the motor can not find the Grid still. ERR15 will be shown up.

MCM# 410~420 System Reserved !

- 421. X-axis origin switch (+: N.O node; -: N.C node)
- 422. Y-axis origin switch (+: N.O node; -: N.C node)
- 423. Z-axis origin switch (+: N.O node; -: N.C node)
- 424. A-axis origin switch (+: N.O node; -: N.C node)
- 425. B-axis origin switch (+: N.O node; -: N.C node)
- 426. C-axis origin switch (+: N.O node; -: N.C node)
- 427. U-axis origin switch (+: N.O node; -: N.C node)
- 428. V-axis origin switch (+: N.O node; -: N.C node)
- 429. W-axis origin switch (+: N.O node; -: N.C node)

Example: MCM 421=5

Set I5 to be the X-axis origin signal with format NO

MCM 425=-6

Set I6 to be the A-axis origin signal with format NC

※ **Default = 0, Functions are inactive, ≠ 0, Functions are active.**

※If a homing process with C64-69 is planned in PLC, it shall be based on the activity set by PLC.

MCM# 430~440 System Reserved !

- 441. Direction of Motor Rotation, X-axis.
- 442. Direction of Motor Rotation, Y-axis.
- 443. Direction of Motor Rotation, Z-axis.
- 444. Direction of Motor Rotation, A-axis.
- 445. Direction of Motor Rotation, B-axis.
- 446. Direction of Motor Rotation, C-axis.
- 447. Direction of Motor Rotation, U-axis.
- 448. Direction of Motor Rotation, V-axis.
- 449. Direction of Motor Rotation, W-axis.

Format : □ , (Default=0)

Setting = 0, Motor rotates in the positive direction. (CW)

Setting = 1, Motor rotates in the negative direction. (CCW)

This MCM can be used to reverse the direction of motor rotation if desired. So you don't have to worry about the direction of rotation when installing motor. These parameters will affect the direction of HOME position

IMPORTANT: Motor Divergence

Due to the variations in circuit design of the servo drivers that are available from the market, the proper electrical connections from servo encoder to the driver, then to the CNC controller may vary. If the connections do not match properly, the motor RPM may become divergent (Rotate @ HIGH RPM) and damage to the machine may result. For this reason, HUST strongly suggest separate the servo motor and the machine before you are 100% sure the direction of the motor rotation. If a motor divergence occurs, please inter-change the connections of (A and B phase) and (A- and B- phase) on the driver side.

(This statement has nothing to do with MCM #154~ #157 but it's very important when connecting electrical motor.)

If a motor divergence occurs, please inter-change the connections of (A and B phase) and (A- and B- phase) on the driver side.

EX:

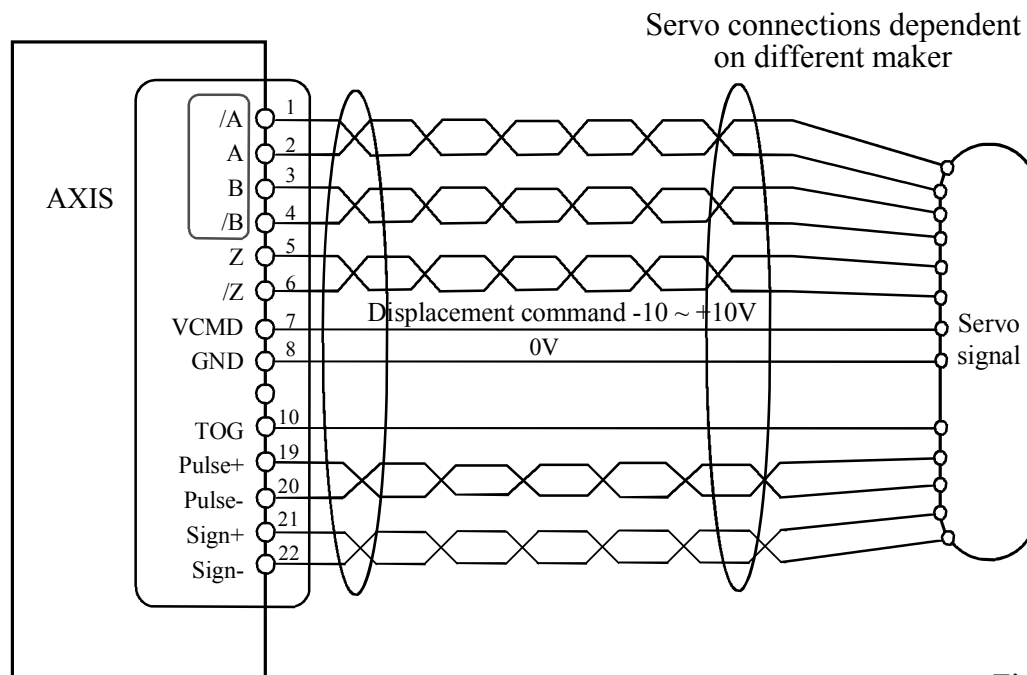

Fig 7.3

MCM# 450~460 System Reserved !

- 461. Encoder Multiplication Factor, X-axis.
 - 462. Encoder Multiplication Factor, Y-axis.
 - 463. Encoder Multiplication Factor, Z-axis.
 - 464. Encoder Multiplication Factor, A-axis.
 - 465. Encoder Multiplication Factor, B-axis.
 - 466. Encoder Multiplication Factor, C-axis.
 - 467. Encoder Multiplication Factor, U-axis.
 - 468. Encoder Multiplication Factor, V-axis.
 - 469. Encoder Multiplication Factor, W-axis.
- Format : □ , (Default=4)

Only one the following 3 numbers:

Setting = 1, Encoder pulse number is multiplied by 1.

Setting = 2, Encoder pulse number is multiplied by 2.

Setting = 4, Encoder pulse number is multiplied by 4.

Note:

The setting of multiplication is highly relative with machine's rigidity. If a motor divergence occurs too heavily, it means that the rigidity is too big. And then it can be improved by lowering the multiplication.

Ex: If factor = 2 for MCM #161 and the encoder resolution is 2000 pulses/rev, then the feed-back signals = $2000 * 2 = 4000$ pulses/rev for Y-axis.

MCM# 470~480 System Reserved !

- 481. X-axis impulse command width adjustment.

- 482. Y-axis impulse command width adjustment.
 - 483. Z-axis impulse command width adjustment.
 - 484. A-axis impulse command width adjustment.
 - 485. B-axis impulse command width adjustment.
 - 486. C-axis impulse command width adjustment.
 - 487. U-axis impulse command width adjustment.
 - 488. V-axis impulse command width adjustment.
 - 489. W-axis impulse command width adjustment.
- Format= (Default=4)

Setting range 1~63 ◦

Used to adjust each axial impulse command width

If the pulse frequency from H6D/H9D controller is 1Hz, then the cycle time of a pulse is 0.25us. If it is required to extend the pulse cycle time, it can be achieved through adjustment of the impulse width.

For example:

If MCM 486=4, the impulse cycle time in the X-axis direction is $4 \times 0.25 = 1.5\text{us}$ and the frequency is 625KHz.

MCM# 490~500 System Reserved !

501. Master/Slave Mode Setting

Format : , (Default=0)

Setting = 0, CNC mode, Master/Slave mode NOT set.

- = 1, X-axis as master axis, Y, Z, A, B, C, U, V, W-axis as slave axes.
- = 2, Y-axis as master axis, X, Z, A, B, C, U, V, W-axis as slave axes.
- = 3, Z-axis as master axis, X, Y, A, B, C, U, V, W-axis as slave axes.
- = 4, A-axis as master axis, X, Y, Z, B, C, U, V, W-axis as slave axes.
- = 5, B-axis as master axis, X, Y, Z, A, C, U, V, W-axis as slave axes.
- = 6, C-axis as master axis, X, Y, Z, A, B, U, V, W-axis as slave axes.
- = 7, U-axis as master axis, X, Y, Z, A, B, C, V, W-axis as slave axes.
- = 8, V-axis as master axis, X, Y, Z, A, B, C, U, W-axis as slave axes.
- = 9, W-axis as master axis, X, Y, Z, A, B, C, U, V-axis as slave axes.
- = 256, Round Corner Non-stop Operation

502. Type of Motor Acceleration/Deceleration

Format : , (Default=1)

Setting = 1, Linear type.

Setting = 2, "S" curve.

503. Home command mode setting.

- BIT0 = 0 X axis find Home grid available, =1 X axis no need to find Home grid.
- BIT1 = 0 Y axis find Home grid available, =1 Y axis no need to find Home grid.
- BIT2 = 0 Z axis find Home grid available, =1 Z axis no need to find Home grid.
- BIT3 = 0 A axis find Home grid available, =1 A axis no need to find Home grid.
- BIT4 = 0 B axis find Home grid available, =1 B axis no need to find Home grid.
- BIT5 = 0 C axis find Home grid available, =1 C axis no need to find Home grid.

BIT6 = 0 U axis find Home grid available, =1 U axis no need to find Home grid.
 BIT7 = 0 V axis find Home grid available, =1 V axis no need to find Home grid.
 BIT8 = 0 W axis find Home grid available, =1 W axis no need to find Home grid.

504. Servo Motor Acceleration/Deceleration Time, G00.
 Format : □□□ , Unit: millisecond (Default=100)
 Setting Range: 2 ~ 3000 millisecond
505. Servo Motor Acceleration/Deceleration Time (T), G01.
 Format : □□□ , Unit: millisecond (Default=100)
 Setting Range: 2 ~ 3000 millisecond.
 100 milliseconds is the recommended setting for both G00 and G01.
- If MCM #502 setting = 0, type of accel./decel. for G01 = exponential
 If MCM #502 setting = 1, type of accel./decel. for G01 = Linear.
 If MCM #502 setting = 2, type of acceleration/deceleration for G01 = "S" curve.
 In this case, the actual acceleration/deceleration time is twice the setting value.
506. Acceleration/Deceleration Time for G99 Mode.
 Format : □□□ , Unit: Millisecond (Default=100)
 Setting Range: 4 ~ 3000 ms.
507. Set the spindle Acceleration/Deceleration time in master mode.
 Format : □□□ , Unit: Millisecond (Default=100)
 Setting Range: 4 ~ 3000 ms.
508. Spindle Encoder Pulse Per Revolution
 Format : □□□□ , Unit: Pulse/rev (Default=4096)
509. Set Spindle Motor RPM When Vcmd = 10 Volt.
 Format : □□□□ , Unit: RPM (Default=3000)
510. Spindle voltage command 0V output balance adjustment (open circuit).
511. Spindle voltage command slope correction (open circuit).
 Format : S= □□□□ , (Default=0), Set the reference value 2047.
512. Spindle RPM correction (based on feedback from the encoder).
513. Starting Number for Auto Generation of Program Block Number.
 Format : S= □ , (Default=0)
514. Increment for Auto-generation of Program Block Number.
 Format : D= □ , (Default=0)
515. If D = 0, the program block number of a single program block will not be generated automatically.
 In the Edit or Teach mode, the block number of a single block can be automatically generated by simply press the INSERT key. If the RESET key is

pressed, the block number of a single block will be renumbered according to the setting values in Parameters 514 and 515.

Ex: S = 0 , D = 5

The program block number will be generated in the sequence: 5,10,15,20,25 ...

516. Denominator of Feed-rate Multiplication Factor for MPG Test.

517. Numerator of Feed-rate Multiplication Factor for MPG Test.

Format : □□□□ , (Default=100)

Note: If the MPG rotation speed is not proper, it can be adjusted by MCM#516, #517. The two items are up to 5 units and it must be integer. They also can not set as zero.

518. Handwheel direction

Format=□ (Default= 0).

If it is necessary to change the relation between the current handwheel rotational direction and the axial displacement direction, it can be achieved by setting the value to 0 or 1.

It can be adjusted separately the corresponding axial direction bit 0 =x bit 1 =y....

Example: BIT 0=1 The X-axis handwheel command is reverse, but other axes remain at the default.

519. Set Acceleration / Deceleration Time for MPG

Format=□□□, (Default = 64), Unit: milliseconds

Setting Range: 4~512 ms.

The motor acceleration / deceleration time is equal to MCM #519 when MPG hand-wheel is used in JOG mode.

520. RS232C Baud Rate.

Format : □□□□ , (Default = 38400)

Set RS232C communication speed. Choose from, 9600, 19200, 38400, 57600, 115200 Speed rate 38400 stands for 38400 bits per second.

In addition, use the following settings for your PC:

Parity -- Even

Stop Bits -- 2 bits

Data Bits – 7 bits

521. Flag to Save the Data of R000~R199 in PLC when power-off.

Format : □ , (Default=0)

Setting = 0, NOT to save.

Setting = 256, Save R000~R199 data.

522. Servo Error Count

Format : □ , (Default=0)

When executing locating operation, the controller has sent out the voltage command, but the motor maybe fall behind some distance. This parameter is used to set that the controller could execute next operation or not according to the setting range of pulse

Set MCM#522 = 0 for generating 4096 pulses.

Set MCM#522 ≠ 0 for user defined value.

523. Radius / diameter programming mode

Format=□ (Default = 0)

0: Radius programming

1: Diameter programming

524. METRIC/INCH Mode Selection (default = 0)

Format : □□□ , (Default = 0)

Setting = 0, Measurement in METRIC unit.

Setting = 1, Measurement in INCH unit.

525. Error in Circular Cutting

Format : □□□□ , (Default = 1)

Range:1 ~ 32

In circular cutting, the ideal cutting path is a circular arc, but the actual motor path is along the arc cord (a straight line). Therefore, there is a cutting error as shown in the figure below.

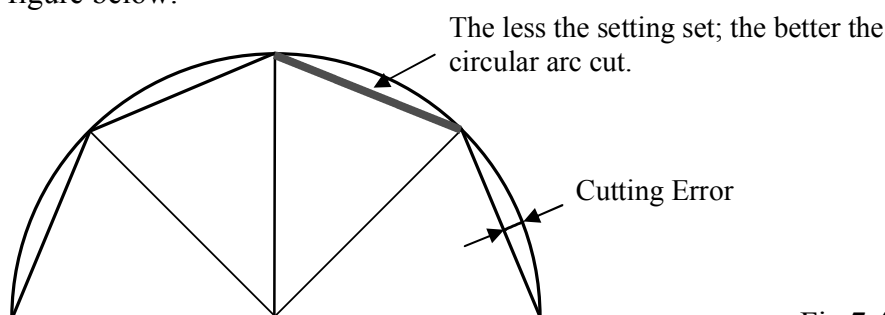

Fig 7.4

This parameter enables the user to adjust acceptable error. The smaller is the setting (=1, the best), the better the circular cutting result. However, the setting should not be too small to the point that it's not able to drive the motor.

526. 6-axis parameter settings in pulse type

Format =□□□□, Default: 0

Setting =0: pulse + direction

Setting =1: +/- pulse
 Setting =2: in the format of Phase A or B

527. Setting the G01 speed value at booting
 Format=□□□□□□ (Default=1000)

After booting, in executing the program or MDI command, if you have not used the F command yet, nor the current single block has designated the F value, then use the MCM 527 value as the F value of the current single block.

528. Setting the tool compensation direction
 Format=□ (Default=0)

0 : HUST

1 : FANUC

Tool-wear compensation direction - HUST: same direction; FANUC: reverse direction.

529. It is used for adjusting the G01's acceleration/deceleration time when the acceleration/deceleration type is set to an "S" curve.
 Format=□□□ (Default=100) in unit of millisecond (msec).
 When MCM 502=2, the function can then be sustained.
 Setting range 10~512 ms.

531. Line editing entry format and numeral decimal's automatic-generating setting.
 Format=□ (default setting 0)

=0 The standard mode.

=1 When setting the parameter values in the system master list, the system will automatically add a decimal point to even numbers.

Ex : MCM 401 setting

Enter " 1 " =1.000

Enter " 1.999 " =1.999

=2 Line Editing.

Ex : Enter G00 X10.

Standard mode steps :

| | | | |
|--------|--------|--------|--------|
| Step 1 | Step 2 | Step 3 | Step 4 |
| GOO | ENTER | X10. | ENTER |

Line editing :

| | |
|----------|--------|
| Step 1 | Step 2 |
| GOO X10. | ENTER |

=4 At editing, decimal point will be automatically generated for the variable value.

At program editing and also entering even numbers, the system will automatically add decimal point to even numbers.

532. In the milling mode, set the gap for drill to withdraw.
Format= $\square.\square\square\square$ (Default= 2.000) unit:mm
533. Setting the test following count
Format= $\square\square\square\square\square\square$ (Default= 0)
With use of parameter Item No.534
534. Testing the axial setting of the servo following error function
Format= $\square\square\square$ (Default = 0)
Set the testing corresponding to the axis with Bit

Description:

When MCM534=1 and Bit0 = 1, test the X-axis.
When MCM534=2 and Bit1 = 1, test the Y-axis.
When MCM534=4 and Bit2 = 1, test the Z-axis.
When MCM534=8 and Bit3 = 1, test the A-axis.
When MCM534=16 and Bit4 = 1, test the B-axis.
When MCM534=32 and Bit5 = 1, test the C-axis.
When MCM534=64 and Bit6 = 1, test the U-axis.
When MCM534=128 and Bit7 = 1, test the V-axis.
When MCM534=256 and Bit8 = 1, test the W-axis.

When MCM534=511, i.e. Bit0 ~ Bit8= 1, then test X/Y/Z/A/B/C/U/V/W-axes at the same time.

Caution: For HUST H6D/H9D controller, if the servo motor used is a voltage command type, it is necessary to set testing the following error function (not applicable for the impulse command type).

The controller will compare the actual feedback difference of the servo motor with the setting of the parameter Item No 533. If the controller detects that the axis has been set beyond the range, the system will display an error message.

Example: When the parameter Item No 533= 4096, the parameter Item No 534=1, and

The actual motor following error

>

4096 (Parameter Item No 533), it will generate ERROR 02 X

535. Controller ID number
Control connection of multiple units with PC. Currently, the function is reserved.

536. Setting the minimum slope of the Auto Teach function
Format=□□□□.□□ (Default= 0)
Setting range: +360.00 ~ -360.00

537. Setting the first point distance of the Auto Teach function.
Format=□□□□.□□□ (Default= 0)

538. G41 and G42 Handling type
Format=□ (Default 0)

When the setting value =0, an error is displayed, the interference problem is not handled, and the motion is stopped.

=1 Automactilly handle the interference problem.

=2 The error message is not displayed and the interference problem is not handeled.

539. System Reserved

540. Adjustment of the feedback direction for the axes
Format=□□□ (Default 0)
Set the corresponding axes by the bit pattern.

Description:

If MCM540 = 1, Bit0 = 1, the feedback direction is reverse for the X-axis.

If MCM540 = 2, Bit1 = 1, the feedback direction is reverse for the Y-axis.

If MCM540 = 4, Bit2 = 1, the feedback direction is reverse for the Z-axis.

If MCM540 = 8, Bit3 = 1, the feedback direction is reverse for the A-axis.

If MCM540 = 16, Bit4 = 1, the feedback direction is reverse for the B-axis.

If MCM540 = 32, Bit5 = 1, the feedback direction is reverse for the C-axis.

If MCM540 = 64, Bit6 = 1, the feedback direction is reverse for the U-axis.

If MCM540 = 128, Bit7 = 1, the feedback direction is reverse for the V-axis.

If MCM540 = 256, Bit8 = 1, the feedback direction is reverse for the W-axis.

541. Arc type
Format=□ (Default 0)

Setting =0 arc cord height control.

=1 arc cord length control.

=2 system internal automatic control (500 sections/sec).

MCM# 542~560 System Reserved !

- 561. "S" curve accel./decel. profile setting for the X-axis.
- 562. "S" curve accel./decel. profile setting for the Y-axis.
- 563. "S" curve accel./decel. profile setting for the Z-axis.
- 564. "S" curve accel./decel. profile setting for the A-axis.
- 565. "S" curve accel./decel. profile setting for the B-axis.
- 566. "S" curve accel./decel. profile setting for the C-axis.
- 567. "S" curve accel./decel. profile setting for the U-axis.
- 568. "S" curve accel./decel. profile setting for the V-axis.
- 569. "S" curve accel./decel. profile setting for the W-axis.

When R209 Bit30=1, the "S" curve accel./decel. profile settings can be configured independently.

MCM# 570~580 System Reserved !

- 581. Software OT Limit in (+) Direction, X-axis. (Group 1)
 - 582. Software OT Limit in (+) Direction, Y-axis. (Group 1)
 - 583. Software OT Limit in (+) Direction, Z-axis. (Group 1)
 - 584. Software OT Limit in (+) Direction, A-axis. (Group 1)
 - 585. Software OT Limit in (+) Direction, B-axis. (Group 1)
 - 586. Software OT Limit in (+) Direction, C-axis. (Group 1)
 - 587. Software OT Limit in (+) Direction, U-axis. (Group 1)
 - 588. Software OT Limit in (+) Direction, V-axis. (Group 1)
 - 589. Software OT Limit in (+) Direction, W-axis. (Group 1)
- Format : □□□□□□□ , Unit: mm/min (Default=9999.999)

Set the software over-travel (OT) limit in the positive (+) direction, the setting value is equal to the distance from positive OT location to the machine origin (HOME).

MCM# 590~600 System Reserved !

- 601. Software OT Limit in (-) Direction, X-axis. (Group 1)
 - 602. Software OT Limit in (-) Direction, Y-axis. (Group 1)
 - 603. Software OT Limit in (-) Direction, Z-axis. (Group 1)
 - 604. Software OT Limit in (-) Direction, A-axis. (Group 1)
 - 605. Software OT Limit in (-) Direction, B-axis. (Group 1)
 - 606. Software OT Limit in (-) Direction, C-axis. (Group 1)
 - 607. Software OT Limit in (-) Direction, U-axis. (Group 1)
 - 608. Software OT Limit in (-) Direction, V-axis. (Group 1)
 - 609. Software OT Limit in (-) Direction, W-axis. (Group 1)
- Format : □□□□.□□□ , Unit: mm/min (Default=-9999.999)

Set the software over-travel (OT) limit in the negative (-) direction, the setting value is equal to the distance from negative OT location to the machine origin (HOME). Figure below shows the relationship among the software OT limit, the emergency stop, and the actual hardware limit.

MCM# 610~620 System Reserved !

- 621. Software OT Limit in (+) Direction, X-axis. (Group 2)
 - 622. Software OT Limit in (+) Direction, Y-axis. (Group 2)
 - 623. Software OT Limit in (+) Direction, Z-axis. (Group 2)
 - 624. Software OT Limit in (+) Direction, A-axis. (Group 2)
 - 625. Software OT Limit in (+) Direction, B-axis. (Group 2)
 - 626. Software OT Limit in (+) Direction, C-axis. (Group 2)
 - 627. Software OT Limit in (+) Direction, U-axis. (Group 2)
 - 628. Software OT Limit in (+) Direction, V-axis. (Group 2)
 - 629. Software OT Limit in (+) Direction, W-axis. (Group 2)
- Format : □□□□□□ , Unit: mm/min (Default=9999.999)

- ※ In PLC when C10=1, it detects unit 2 software's range limit.
- ※ Set the software over-travel (OT) limit in the positive (+) direction, the setting value is equal to the distance from positive OT location to the machine origin (HOME).

MCM# 630~640 System Reserved !

- 641. Software OT Limit in (-) Direction, X-axis. (Group 2)
 - 642. Software OT Limit in (-) Direction, Y-axis. (Group 2)
 - 643. Software OT Limit in (-) Direction, Z-axis. (Group 2)
 - 644. Software OT Limit in (-) Direction, A-axis. (Group 2)
 - 645. Software OT Limit in (-) Direction, B-axis. (Group 2)
 - 646. Software OT Limit in (-) Direction, C-axis. (Group 2)
 - 647. Software OT Limit in (-) Direction, U-axis. (Group 2)
 - 648. Software OT Limit in (-) Direction, V-axis. (Group 2)
 - 649. Software OT Limit in (-) Direction, W-axis. (Group 2)
- Format : □□□□.□□□ , Unit: mm/min (Default=-9999.999)

- ※ In PLC when C10=1, it detects unit 2 software's range limit.
- ※ Set the software over-travel (OT) limit in the negative (-) direction, the setting value is equal to the distance from negative OT location to the machine origin (HOME).

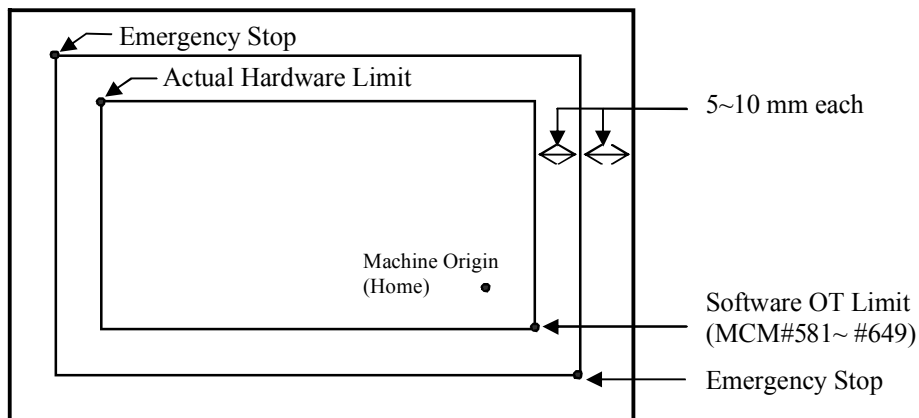

Fig 7.5

MCM# 650~660 System Reserved !

- 661. Flag to Clear X-axis Program Coordinate on M02, M30 or M99 Command.
 - 662. Flag to Clear Y-axis Program Coordinate on M02, M30 or M99 Command.
 - 663. Flag to Clear Z-axis Program Coordinate on M02, M30, or M99 Command.
 - 664. Flag to Clear A-axis Program Coordinate on M02, M30, or M99 Command.
 - 665. Flag to Clear B-axis Program Coordinate on M02, M30, or M99 Command.
 - 666. Flag to Clear C-axis Program Coordinate on M02, M30, or M99 Command.
 - 667. Flag to Clear U-axis Program Coordinate on M02, M30, or M99 Command.
 - 668. Flag to Clear V-axis Program Coordinate on M02, M30, or M99 Command.
 - 669. Flag to Clear W-axis Program Coordinate on M02, M30, or M99 Command.
- Format : □ , (Default=0)

Used as flag to clear the coordinate when program execution encounters M02, M30 or M99 function. The following settings are valid for both X and Y-axis.

Setting = 0, Flag is OFF, NOT to clear.

Setting = 1, Flag is ON, YES to clear when encountering M02 and M30.

Setting = 2, Flag is ON, YES to clear when encountering M99.

Setting = 3, Flag is ON, YES to clear when encountering M02, M30 and M99.

MCM# 670~680 System Reserved !

- 681. Set Incremental/Absolute Mode, X-axis coordinate.
 - 682. Set Incremental/Absolute Mode, Y-axis coordinate.
 - 683. Set Incremental/Absolute Mode, Z-axis coordinate.
 - 684. Set Incremental/Absolute Mode, A-axis coordinate.
 - 685. Set Incremental/Absolute Mode, B-axis coordinate.
 - 686. Set Incremental/Absolute Mode, C-axis coordinate.
 - 687. Set Incremental/Absolute Mode, U-axis coordinate.
 - 688. Set Incremental/Absolute Mode, V-axis coordinate.
 - 689. Set Incremental/Absolute Mode, W-axis coordinate.
- Format : □ , (Default=1) for absolute positioning

Ex: Set MCM 681 = 0, X value represents the incremental position and U value is ineffective.

= 1, X value represents the incremental position and U value is the incremental position.

*Note 1: After the parameters are set, execute the command **G01 X***,Y***,Z*** F*****, the program will perform the axial motions according to the configured incremental or absolute positions.

H9D: When R209 = 4, the incremental address codes of X,Y,Z will be U,V,W. However, the A,B,C axes have no incremental address code, they cannot be used in the same way as the X,Y,Z axes which allow the conversion between the incremental positioning and the absolute positioning. It is necessary to use the **G90/G91** modes to use them.

H9D: X,Y,Z,A,B,C,U,V,W have no incremental address codes, so they cannot allow the conversion between the incremental

positioning and the absolute positioning. It is necessary to use the G90/G91 mode to use them.

- *Note 2: For H9D using the incremental address codes U,V,W, it is necessary to set the parameters 1 of the X,Y,Z axes for the absolute positioning so that the U,V,W commands can be performed in the program.
- *Note 3: If the G90/G91 mode is used for the 9-axis absolute or incremental positioning change, no matter the parameters are configured for absolute positioning or for incremental positioning, the single block X,Y,Z,A,B,C,U,V,W commands will use the G90/G91 mode for absolute positioning or absolute increments after the G90/G91 mode is used.
- *Note 4: When the controller in H9D is configured to use U,V,W as the incremental address codes, it will not be influenced by the G90/G91 mode.

Format of mode appointment:

G90 Absolute coordinate
 G91 Incremental coordinate

1. G90 :

When writing G90 in the program, all the axes of X,Y,Z,A,B,C,U,V,W are the absolute coordinate. All following nodes` axes direction will also feed absolutely. (See EX1)
 The incremental codes U,V,W also can be used in G90 mode. Then X, Y, Z axes will feed incrementally. But A-axis still feed absolutely. Until it meeting G91 or recycling the program, then the G90 will be over.

EX1: G90 Set Absolute Coordinate

```
N1 G90
N2 G1 X20.000 Y15.000      ....    P0 to P1
N3 X35.000 Y25.000      ....    P1 to P2
N4 X60.000 Y30.000      ....    P2 to P3
```

2. G91 :

When writing G90 in the program, all the axes of X,Y,Z,A,B,C,U,V,W are the incremental coordinate. All following nodes` axes direction will also feed incrementally. (See EX2)

In G91 mode, X,Y,Z represent the incremental value. The codes of U, V, W are not necessary. The axis will move to nowhere.

Until it meeting G90 or recycling the program, then the G91 will be over.

EX2: G91 Set Incremental Coordinate

```
N1 G91
N2 G1 X20.000 Y15.000      ....    P0 to P1
N3 X15.000 Y10.000      ....    P1 to P2
N4 X25.000 Y5.000       ....    P2 to P3
```

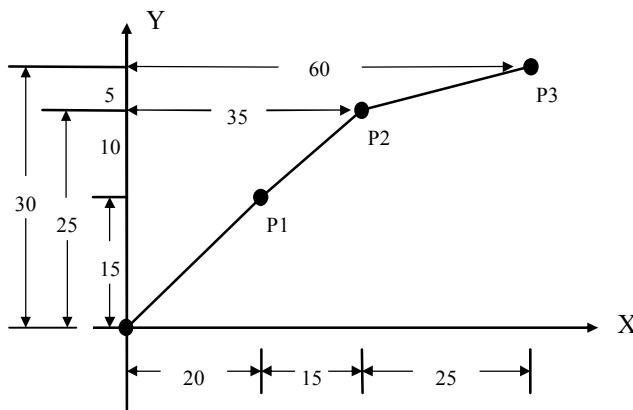



Fig 7.6

MCM# 690~700 System Reserved !

- 701. X-axis, Position gain.
- 702. Y-axis, Position gain.
- 703. Z-axis, Position gain.
- 704. A-axis, Position gain.
- 705. B-axis, Position gain.
- 706. C-axis, Position gain.
- 707. U-axis, Position gain.
- 708. V-axis, Position gain.
- 709. W-axis, Position gain.

Format : □□□ , (Default=64) , Setting Range: 8~640 ◦

Parameters 701~709 are used to set the loop gain. The recommended value is 64. This setting value is essential to the smooth operation of the motor. Once it is configured, please do not change it arbitrarily.

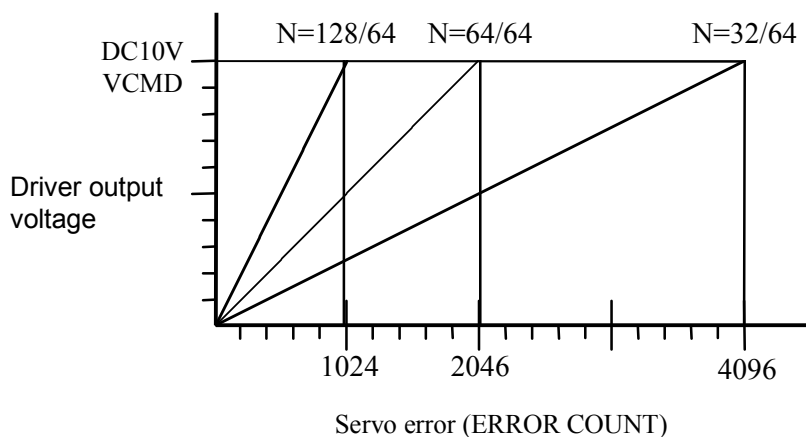

Fig 7-7 Driver output voltage vs. the servo error

The position gain and HUST H6D/H9D output voltage command can be calculated as follows:

$$\text{Position Gain} = \frac{\text{Setting value}}{64}$$

$$\text{NC controller output voltage command} \\ = \text{GAIN} * \text{Servo feedback error} * \left(\frac{10\text{V}}{2048} \right)$$

The controller in HUST is a closed-loop system. The servo error is the difference between the controller position command and the actual feedback value of the servo motor. The controller will adjust the output voltage of the controller properly according to this difference value. The setting value of the position gain is related to the stability and the follow-up of the system servo, so please modify it with care. If:

Servo mismatch > 4096, the ERROR 02 will occur.

In this case, please correct the values of MCM Parameters 701~709 and then press the “Reset” key. If the problem still exists, please check if the wire connection of the servo motor is correct.

Adjustment procedure for smooth motor operation: (recommended)

- (1) Adjust the servo driver. (Please refer to the operation manual of the driver)
- (2) Adjust the MCM Parameters 461~469 for the multipliers (1,2,4) of the signals from the the speed sensors. In normal condition, if the motor is locked, the Servo Error will be oscillating between 0 and 1; if it is oscillating between 4 and 5, the problem can be solved usually by adjusting the MCM Parameters 461~469 for the multipliers, i.e., 4 --> 2, or 2 --> 1.
- (3) Adjust the values of MCM Parameters 701~709 for the position loop gain.

MCM# 710~720 System Reserved !

- 721. Break-over Point (in Error Count) for Position Gain, X-axis.
 - 722. Break-over Point (in Error Count) for Position Gain, Y-axis.
 - 723. Break-over Point (in Error Count) for Position Gain, Z-axis.
 - 724. Break-over Point (in Error Count) for Position Gain, A-axis.
 - 725. Break-over Point (in Error Count) for Position Gain, B-axis.
 - 726. Break-over Point (in Error Count) for Position Gain, C-axis.
 - 727. Break-over Point (in Error Count) for Position Gain, U-axis.
 - 728. Break-over Point (in Error Count) for Position Gain, V-axis.
 - 729. Break-over Point (in Error Count) for Position Gain, W-axis.
- Format : □□□ , (Default=10)

The proper setting of this parameter will assure smooth start-up of servo motor. When servo error is smaller than the setting value of MCM #721~#729, the position gain is 64. Otherwise, position gain will be calculated based on the setting value of MCM #701~ #709 and the setting values depend on the frictional load on the motor. If the frictional load is high, setting value is small and vice versa.

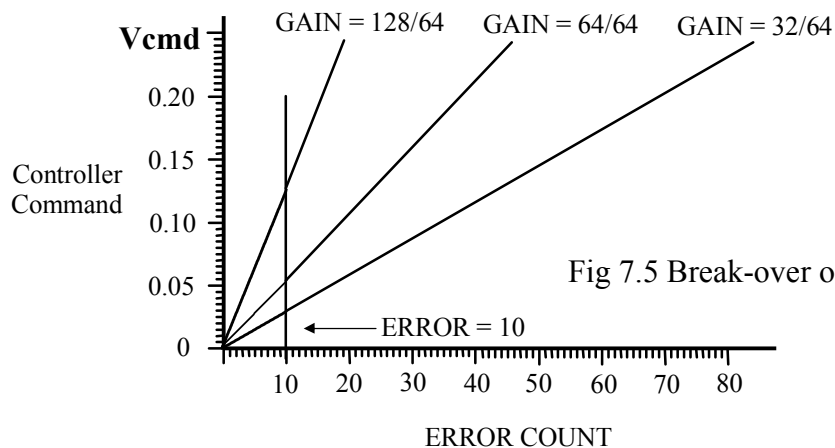

Fig 7.7

MCM# 730~740 System Reserved !

- | | | |
|------|---------------------|---|
| 741. | X-axis Denominator, | MPG Hand-wheel Resolution Adjustment. (pulse) |
| 742. | X-axis Numerator, | MPG Hand-wheel Resolution Adjustment. (μm) |
| 743. | Y-axis Denominator, | MPG Hand-wheel Resolution Adjustment. (pulse) |
| 744. | Y-axis Numerator, | MPG Hand-wheel Resolution Adjustment. (μm) |
| 745. | Z-axis Denominator, | MPG Hand-wheel Resolution Adjustment. (pulse) |
| 746. | Z-axis Numerator, | MPG Hand-wheel Resolution Adjustment. (μm) |
| 747. | A-axis Denominator, | MPG Hand-wheel Resolution Adjustment. (pulse) |
| 748. | A-axis Numerator, | MPG Hand-wheel Resolution Adjustment. (μm) |
| 749. | B-axis Denominator, | MPG Hand-wheel Resolution Adjustment. (pulse) |
| 750. | B-axis Numerator, | MPG Hand-wheel Resolution Adjustment. (μm) |
| 751. | C-axis Denominator, | MPG Hand-wheel Resolution Adjustment. (pulse) |
| 752. | C-axis Numerator, | MPG Hand-wheel Resolution Adjustment. (μm) |
| 753. | U-axis Denominator, | MPG Hand-wheel Resolution Adjustment. (pulse) |
| 754. | U-axis Numerator, | MPG Hand-wheel Resolution Adjustment. (μm) |
| 755. | V-axis Denominator, | MPG Hand-wheel Resolution Adjustment. (pulse) |
| 756. | V-axis Numerator, | MPG Hand-wheel Resolution Adjustment. (μm) |
| 757. | W-axis Denominator, | MPG Hand-wheel Resolution Adjustment. (pulse) |
| 758. | W-axis Numerator, | MPG Hand-wheel Resolution Adjustment. (μm) |
- Format : □□□□ , (Default = 100)
- Unit: Denominator = pulses, Numerator = μm

Ex1: For X-axis, MCM #741 = 100 pulses, MCM #742 = 100 μm .

The resolution for X-axis = $100/100 = 1 \mu\text{m}/\text{pulse}$.

If MPG hand-wheel moves 1 notch (=100 pulses), the feed length in X-axis
= $100 \times (100/100) = 100 \mu\text{m} = 0.1 \text{ mm}$.

Ex2: For Y-axis, MCM #743 = 200 pulses, MCM #744 = 500 μm .
The resolution for Y-axis = $500/200 = 2.5 \mu\text{m/pulse}$.
If MPG hand-wheel moves 1 notch (=100 pulses), the feed length in Y-axis
= $100 \times (500/200) = 250 \mu\text{m} = 0.25 \text{ mm}$.

MCM# 759~780 System Reserved !

- 781. Set if X-axis is rotational axis.
 - 782. Set if Y-axis is rotational axis.
 - 783. Set if Z-axis is rotational axis.
 - 784. Set if A-axis is rotational axis.
 - 785. Set if B-axis is rotational axis.
 - 786. Set if C-axis is rotational axis.
 - 787. Set if U-axis is rotational axis.
 - 788. Set if V-axis is rotational axis.
 - 789. Set if W-axis is rotational axis.
- Format= (Default 0)

Setting= 0 Linear Axis
Setting= 1 Rotational Axis

MCM# 787~800 System Reserved !

- 801. The distance of S bit sent before the X-axis reaches in position. (S176)
 - 802. The distance of S bit sent before the Y-axis reaches in position. (S177)
 - 803. The distance of S bit sent before the Z-axis reaches in position. (S178)
 - 804. The distance of S bit sent before the A-axis reaches in position. (S179)
 - 805. The distance of S bit sent before the B-axis reaches in position. (S180)
 - 806. The distance of S bit sent before the C-axis reaches in position. (S181)
 - 807. The distance of S bit sent before the U-axis reaches in position. (S182)
 - 808. The distance of S bit sent before the V-axis reaches in position. (S183)
 - 809. The distance of S bit sent before the W-axis reaches in position. (S184)
- Format= (Default= 0.000)
- Unit: mm

For example: MCM 801 =10.00mm
Giving the command: When G01 U30.000 F1000, when the X-axis move
20.000mm and 10.000mm away from the final value, the system will send
S176=ON ◦

MCM# 807~820 System Reserved !

- 821. The accelerate/decelerate time of X-axis.
- 822. The accelerate/decelerate time of Y-axis.
- 823. The accelerate/decelerate time of Z-axis.
- 824. The accelerate/decelerate time of A-axis.
- 825. The accelerate/decelerate time of B-axis.
- 826. The accelerate/decelerate time of C-axis.
- 827. The accelerate/decelerate time of U-axis.

828. The accelerate/decelerate time of V-axis.
 829. The accelerate/decelerate time of W-axis.
 Format=□□□□ (Default 0), Unit (msec)
 Acceleration/Deceleration Time (2~3000)

When R209 Bit30 = 1, the acceleration/deceleration speed can be programmed independently.

MCM# 830~840 System Reserved !

The pitch error compensation of the guide screw in HUST H6D/H9D is relative to the **mechanical origin as the base point**.

841. Pitch Error Compensation Mode Setting, X-axis.
 842. Pitch Error Compensation Mode Setting, Y-axis.
 843. Pitch Error Compensation Mode Setting, Z-axis.
 844. Pitch Error Compensation Mode Setting, A-axis.
 845. Pitch Error Compensation Mode Setting, B-axis.
 846. Pitch Error Compensation Mode Setting, C-axis.
 847. Pitch Error Compensation Mode Setting, U-axis.
 848. Pitch Error Compensation Mode Setting, V-axis.
 849. Pitch Error Compensation Mode Setting, W-axis.
 Format:□, Default=0

Setting = 0, Compensation canceled.
 Setting = -1, Negative side of compensation.
 Setting = 1, Positive side of compensation.

| X-axis | Y-axis | Z-axis | A-axis | B-axis | C-axis | U-axis | V-axis | W-axis | Explanation |
|--------|--------|--------|--------|--------|--------|--------|--------|--------|--|
| 0 | 0 | 0 | 0 | 0 | 0 | 0 | 0 | 0 | Compensation cancel |
| -1 | -1 | -1 | -1 | -1 | -1 | -1 | -1 | -1 | Do compensation when tool is on the (-) side of the reference point |
| 1 | 1 | 1 | 1 | 1 | 1 | 1 | 1 | 1 | Do compensation when tool is on the (+) side of the reference point. |

Ex:

MCM # 841 = -1

The pitch error in the X-axis will not be compensated when the tool travels to the positive side of the X-HOME location. It will be compensated when the tool travels to the negative side of machine origin.

MCM # 841 = 1

The pitch error in the X-axis will be compensated when the tool travels to the positive side of Y-HOME location. No compensation will be done when it travels to the negative side of machine origin.

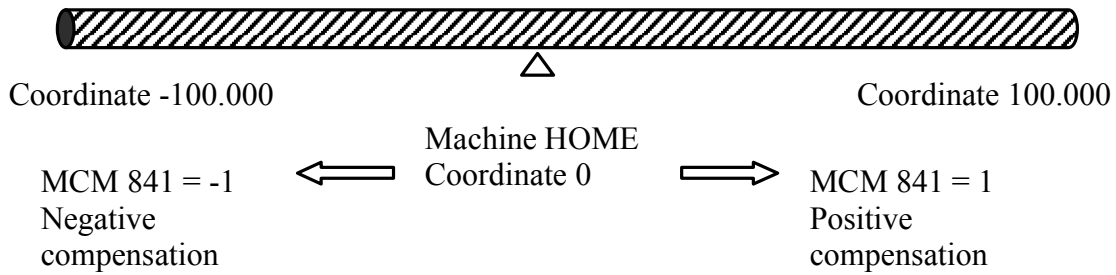

Fig 7.9

MCM#850 System Reserved !

- 851. Segment Length for Pitch Error Compensation, X-axis.
 - 852. Segment Length for Pitch Error Compensation, Y-axis.
 - 853. Segment Length for Pitch Error Compensation, Z-axis.
 - 854. Segment Length for Pitch Error Compensation, A-axis.
 - 855. Segment Length for Pitch Error Compensation, B-axis.
 - 856. Segment Length for Pitch Error Compensation, C-axis.
- Format=□.□□□, Default=0, Unit=mm

| Axis | Corresponding MCM# for Segment Length | Segment Length | Max. Number of Segment |
|------|---------------------------------------|----------------|------------------------|
| X | MCM# 861 ~ 940 | 20 ~ 480 mm | 80 |
| Y | MCM# 941 ~ 1020 | 20 ~ 480 mm | 80 |
| Z | MCM# 1021 ~ 1100 | 20 ~ 480 mm | 80 |
| A | MCM# 1101 ~ 1180 | 20 ~ 480 mm | 80 |
| B | MCM# 1181 ~ 1260 | 20 ~ 480 mm | 80 |
| C | MCM# 1261 ~ 1340 | 20 ~ 480 mm | 80 |

1. Segment length is the total length of ball-screw divided by the number of segment.

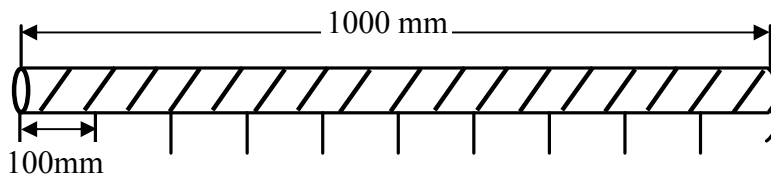

Fig7.10

Ex:

If you want to divide the ball-screw on X-axis, which is 1 meter in length, into 10 segments, the segment length is $1000.00/10=100.00$ mm. This 100.00 mm will be stored in MCM# 851.(Each compensation of them is set by MCM#861~#940)

2. If the average segment length is less than 20 mm, use 20 mm.
3. When doing compensation, HUST H6D/H9D controller will further divide each segment into 8 sections. The amount of compensation for each section is equal to the whole number, in μ m, of 1/8 of the amount in MCM #861~#940. The remainder will be added to the next section.

Ex:

Segment length =100.00mm and the amount of compensation is 0.026mm as set in MCM#861. Then, the compensation for each section is $0.026/8=0.00325$ mm. The compensation for this segment will be done in a manner as tabulated below:

| Section | Tool Position | Avg. comp. For each section | Actual comp. At each section | Accumulated compensation |
|---------|---------------|-----------------------------|------------------------------|--------------------------|
| 1 | 12.5 | 0.00325 | 0.003 | 0.003 |
| 2 | 25 | 0.00325 | 0.003 | 0.006 |
| 3 | 37.5 | 0.00325 | 0.003 | 0.009 |
| 4 | 50 | 0.00325 | 0.004 | 0.013 |
| 5 | 62.5 | 0.00325 | 0.003 | 0.016 |
| 6 | 75 | 0.00325 | 0.003 | 0.019 |
| 7 | 87.5 | 0.00325 | 0.003 | 0.022 |
| 8 | 100 | 0.00325 | 0.004 | 0.026 |

MCM# 857~860 System Reserved !

861~1340. Amount of Compensation for each segment (X.Y.Z.A.B.C-axis) is 80.

The Compensation value is in incremental mode. If the number of segment is less than 80, please fill the uncompensated segments with zero to avoid any potential errors.

Ex:

If the segment of compensation is 10, the amount of the compensation from Seg.11 to 40 (X-axis MCM#861~940, Y-axis MCM#941~1020, Z-axis MCM#1021~1100, A-axis MCM#1101~1180, B-axis MCM#1181~1260, C-axis MCM#1261~1340) must be set as zero.

MCM#861~940 Pitch error compensation of each segment, X-axis.

MCM#941~1020 Pitch error compensation of each segment, Y-axis.

MCM#1021~1100 Pitch error compensation of each segment, Z-axis.

MCM#1101~1180 Pitch error compensation of each segment, A-axis.

MCM#1181~1260 Pitch error compensation of each segment, B-axis.

MCM#1261~1340 Pitch error compensation of each segment, C-axis.

Format : □.□□□ , Unit: mm (Default=0.000)

1341. Tool#1, Radius Offset Data.

1342. X-axis Offset Data, Tool#1.

1343. Y-axis Offset Data, Tool#1.

1344. Z-axis Offset Data, Tool#1.

1345. A-axis Offset Data, Tool#1.

1346. B-axis Offset Data, Tool#1.

1347. C-axis Offset Data, Tool#1.

Format : □.□□□ , Unit: mm (Default=0.000)

1348. Tool#2, Radius offset data.

1349. X-axis offset data, Tool#2.

1350. Y-axis offset data, Tool#2.

1351. Z-axis offset data, Tool#2.

1352. A-axis offset data, Tool#2.

1353. B-axis offset data, Tool#2.

1354. C-axis offset data, Tool#2.

Format : □.□□□ , Unit: mm (Default=0.000)

MCM#1355~1620 : Tool#3~40, Radius offset data and X/Y/Z/A/B/C-axis offset data ◦

1621. Tool #1 radius wear compensation.

1622. X-axis, Tool #1 wear compensation.

1623. Y-axis, Tool #1 wear compensation.

1624. Z-axis, Tool #1 wear compensation.

1625. A-axis, Tool #1 wear compensation.

1626. B-axis, Tool #1 wear compensation.

1627. C-axis, Tool #1 wear compensation.

Format : □.□□□ , Unit: mm (Default=0.000)

1628. Tool #2 radius wear compensation.

1629. X-axis, Tool #2 wear compensation.

1630. Y-axis, Tool #2 wear compensation.

1631. Z-axis, Tool #2 wear compensation.

1632. A-axis, Tool #2 wear compensation.

1633. B-axis, Tool #2 wear compensation.

1634. C-axis, Tool #2 wear compensation.

Format : □.□□□ , Unit: mm (Default=0.000)

MCM#1635~1900 : Tool#3~40, Radius wear compensation and X/Y/Z/A/B/C-axis wear compensation ◦

1901~1940 : Tool-tip radius compensation (Tool-tip#1~40)

* Input signal planning

8.1

| I/O Signal Type | | | | |
|----------------------------------|-------|------|----|---------|
| INPUT | VALUE | 0 | 1 | 2 |
| I00 EM-STOP | | NO | NC | Disable |
| I01 X-axis Home | | NO | NC | Disable |
| I02 Z-axis Home | | NO | NC | Disable |
| I03 X-axis Error | | NO | NC | Disable |
| I04 Z-axis Error | | NO | NC | Disable |
| I05 Spindle 1 Error | | NO | NC | Disable |
| I06 External Start | | NO | | |
| I07 External Feed-Hold | | NO | | |
| I08 Foot Switch | | NO | | |
| I09 Turret | | None | | |
| I10 Turret | | None | | |
| I11 Turret | | None | | |
| I12 Turret | | None | | |
| I13 Turret | | None | | |
| I14 Turret | | None | | |
| I15 Turret | | None | | |
| I16 Multi-function select(表 8.2) | | NO | NC | Disable |
| I17 Multi-function select(表 8.2) | | NO | NC | Disable |
| I18 Multi-function select(表 8.2) | | NO | NC | Disable |
| I19 Multi-function select(表 8.2) | | NO | NC | Disable |
| I20 Multi-function select(表 8.2) | | NO | NC | Disable |
| I21 Multi-function select(表 8.2) | | NO | NC | Disable |
| I22 Multi-function select(表 8.2) | | NO | NC | Disable |
| I23 Multi-function select(表 8.2) | | NO | NC | Disable |
| I24 Y-axis Home | | NO | NC | Disable |
| I25 Y-axis Error | | NO | NC | Disable |
| I26 Y-axis OT+ | | NO | NC | Disable |
| I27 Y-axis OY- | | NO | NC | Disable |

*** Input function planning**

8.2

| Input Function Planning | | | | |
|-------------------------|--------------------|---------------|------------------|----------------------|
| VALUE INPUT | 0 | 1 | 2 | 3 |
| I00 | EM-STOP | None | | |
| I01 | X-axis Home | None | | |
| I02 | Z-axis Home | None | | |
| I03 | X-axis Error | None | | |
| I04 | Z-axis Error | None | | |
| I05 | Spindle1 Error | None | | |
| I06 | External Start | None | | |
| I07 | External Feed-Hold | None | | |
| I08 | Foot Switch | None | | |
| I09 | Turret | Turret type | | |
| I10 | Turret | Turret type | | |
| I11 | Turret | Turret type | | |
| I12 | Turret | Turret type | | |
| I13 | Turret | Turret type | | |
| I14 | Turret | Turret type | | |
| I15 | Turret | Turret type | | |
| I16 | None | MPG X | X-axis OT+ | Sp1 Home Signal1 |
| I17 | None | MPG Z | X-axis OT- | Sp1 Home Signal2 |
| I18 | None | MPG x1 | Z-axis OT+ | Spindle 2 Error |
| I19 | None | MPG x10 | Z-axis OT- | Spindle 3 Error |
| I20 | None | MPG x100 | Sp1 Home Signal1 | Oil Error |
| I21 | None | Security Door | Sp1 Home Signal2 | Chuck Unclamp Signal |
| I22 | None | Oil Error | Spindle 2 Error | Chuck Clamp Signal |
| I23 | None | Coolant Error | Spindle 3 Error | Bar Feeder Reach |

* Output function planning

8.3

| Output Function Planning | | | | |
|--------------------------|------------------------|----------------------|--------------------|------------------|
| 設定値 OUTPUT | 0 | 1 | 2 | 3 |
| 000 | SP1 CW | None | | |
| 001 | SP1 CCW | None | | |
| 002 | Coolant | None | | |
| 003 | Lube | None | | |
| 004 | Lamp RED | None | | |
| 005 | Cutter Head Unclamp | None | | |
| 006 | Cutter Head CW | None | | |
| 007 | Cutter Head CCW | None | | |
| 008 | SP 1 Chuck1 | None | | |
| 009 | None | Tailstock For | Lamp Yellow | Working Light |
| 010 | None | Tailstock Rev | Lamp Green | Buzzer |
| 011 | None | Conveyor CW | SP1 Chuck2 | Bar Feeder Start |
| 012 | None | Conveyor CCW | S-Driver Power Off | Received Box |
| 013 | None | Electric Tool CW | Bar Feeder Start | Tailstock Chuck |
| 014 | None | Electric Tool CCW | Buzzer | Lamp Yellow |
| 015 | None | SP1 Brake | Hydraulic Start | Lamp Green |

*** I/O signal and function planning**

| | | | | | |
|-----------------------------|------------------|---|-----|-------------------|----------|
| Signal 0:NO1:NC 2:Disable | | | | | |
| I00 | EM-stop | 0 | I19 | Z-Axis OT- | 0 |
| I01 | X home | 0 | I20 | SP1 home signal1 | 0 |
| I02 | Z home | 0 | I21 | SP1 home signal2 | 0 |
| I03 | X-axis error | 0 | I22 | Spindle2 error | 0 |
| I04 | Z-axis error | 0 | I23 | Spindle3 error | 0 |
| I05 | Spindle 1 error | 0 | I24 | Y home | 0 |
| I16 | X-axis OT+ | 0 | I25 | Y-axis error | 0 |
| I17 | X-axis OT- | 0 | I26 | Y-axis OT+ | 0 |
| I18 | Z-axis OT+ | 0 | I27 | Y-axis OT- | 0 |
| I/O Function format setting | | | | | |
| I16 | X-axis OT+ | 0 | O09 | Tailstock FOR | 0 |
| I17 | X-axis OT- | 0 | O10 | Tailstock REV | 0 |
| I18 | Z-axis OT+ | 0 | O11 | Conveyor CW | 0 |
| I19 | Z-Axis OT- | 0 | O12 | Conveyor CCW | 0 |
| I20 | SP1 home signal1 | 0 | O13 | Electric tool CW | 0 |
| I21 | SP1 home signal2 | 0 | O14 | Electric tool CCW | 0 |
| I22 | Spindle2 error | 0 | O15 | SP1 brake | 0 |
| I23 | Bar feeder reach | 0 | | | 0 |
| Y-axis OT- | | | | | ▲ PAGE ▼ |
| Back | Change | | | | MCM |
| Main | password | | | | Modify |

Fig.8-1

Input signal setting : 0=NO、1=NC、2=Disable
 I/O planning refer 8.2 and 8.3 °

9 Appendix B – PC On-line Operation

9.1 PC Performs Online Operation via RS232 and The Controller

Through TAPE function, HUST H6D-T can do the following PC (personal computer) on-line operations via RS232C interface. Through MDI mode, you can execute G10 function as shown in Table 9-1 as well as burn the transmitted program, MCM parameters, PLC simulation program, LCD screen display data, and system data into Flash-ROM in the controller.

1. Transfer part program from PC (personal computer) to CNC controller.
2. Transfer a part program from CNC controller to PC.
3. Transfer MCM data from PC to CNC controller.
4. Transfer MCM data from CNC controller to PC.
5. Transfer data variables from PC to CNC controller.
6. Transfer data variables from CNC controller to PC.
7. Transfer PLC ladder program from PC to CNC controller and test the ladder program.
8. Transfer LCD screen display data from PC to CNC controller.
9. Transfer self-designed data from PC to CNC controller.
10. Transfer system data from PC to CNC controller.
11. Transfer filled tables from PC to CNC controller.
12. Transferring while executing the program from PC.

Items 1 ~ 12 can be done from PC side when the controller is under power-on mode but NOT in TAPE mode.

Table 9-1 Online Operation with G10 Function through RS232C Interface

| | |
|------------------|---|
| G10 P510 L38400 | Set the baud rate for RS232 interface at 38400 bps |
| G10 P510 L57600 | Set the baud rate for RS232 interface at 57600 bps |
| G10 P510 L115200 | Set the baud rate for RS232 interface at 115200 bps |
| G10 P600 L01 | Burn the externally transmitted program into Flash-ROM |
| G10 P600 L02 | Burn the externally transmitted MCM parameters into Flash-ROM |
| G10 P600 L03 | Burn the externally transmitted ladder program into Flash-ROM |
| G10 P600 L05 | Burn the externally transmitted controller system data into Flash-ROM |
| G10 P2100 | Load the part program from Flash-ROM to memory |
| G10 P1000 (note) | Load the MCM parameters from Flash-ROM to memory |

Note that MCM data of FLASHROM are the standard settings. The users can execute G10 P600 L02 to save the adjusted settings by burning to FLASHROM memory. If the users want to reverse the former saved settings, simply load the data by executing G10 P1000 from FLAHRROM memory.

Program Transfer from PC to CNC Controller

Format for program transfer:

```

%
  O001          ..... Program number
  N10 G0 X0. Y0. Z0
  N20 G1 X50. Y50. Z45
  N30 U30. V-30. W15
  N40 G0 X0. Y0. Z0
  N50 M2
%
  
```

} Program content

Notes:

1. The program must start and end with a symbol of “%”.
2. Program number range = 000~999
3. One line contains one program block only. Do NOT write multiple program block on the same line as “N10 G0. Y0. N20 G1 X10. Y10. N30 G0 X0. Y0. N40 M2”.
4. When transmitting the program from the PC end to the HUST H6D-T series controller, and if the program transmitted does not contain the program code Oxxx, the transmitted program will cover over the program currently selected on the controller.

Ex: With the controller currently stopping at #6 processing program, and when the transmitted program does not contain the program code Oxxx, the content of the transmitted processing program will directly cover over the #6 processing program currently on the controller.

9.1.1 Program Transfer From PC To CNC Controller

Movement program:

1. The controller is not in a program execution state (where S080=0).
2. On PC side, make sure the transmission is ready to transmit.
Baud Rate should be correct when you execute HCON.exe (See section 10, Chapter 9). After entering Data Transmission Mode (FileSvc),
 - (1) Select “ Send File To CNC : TYPE >>> ”
 - (2) Select “ 1:CNC ”
 - (3) Press “ Open File ” to select the processed program file for transmission.
 - (4) After the confirmation of file, press “ Send Out ”. PC will download the data automatically.

Note:

When the program is in execution (S080=1), you must stop for S080 turning “0” to re-operate the step 4.

Note:

If the program to be transferred has an ID number, after the transmission, it will be stored in the memory with the same number at the CNC side; otherwise, it will replace the program currently used by the controller.

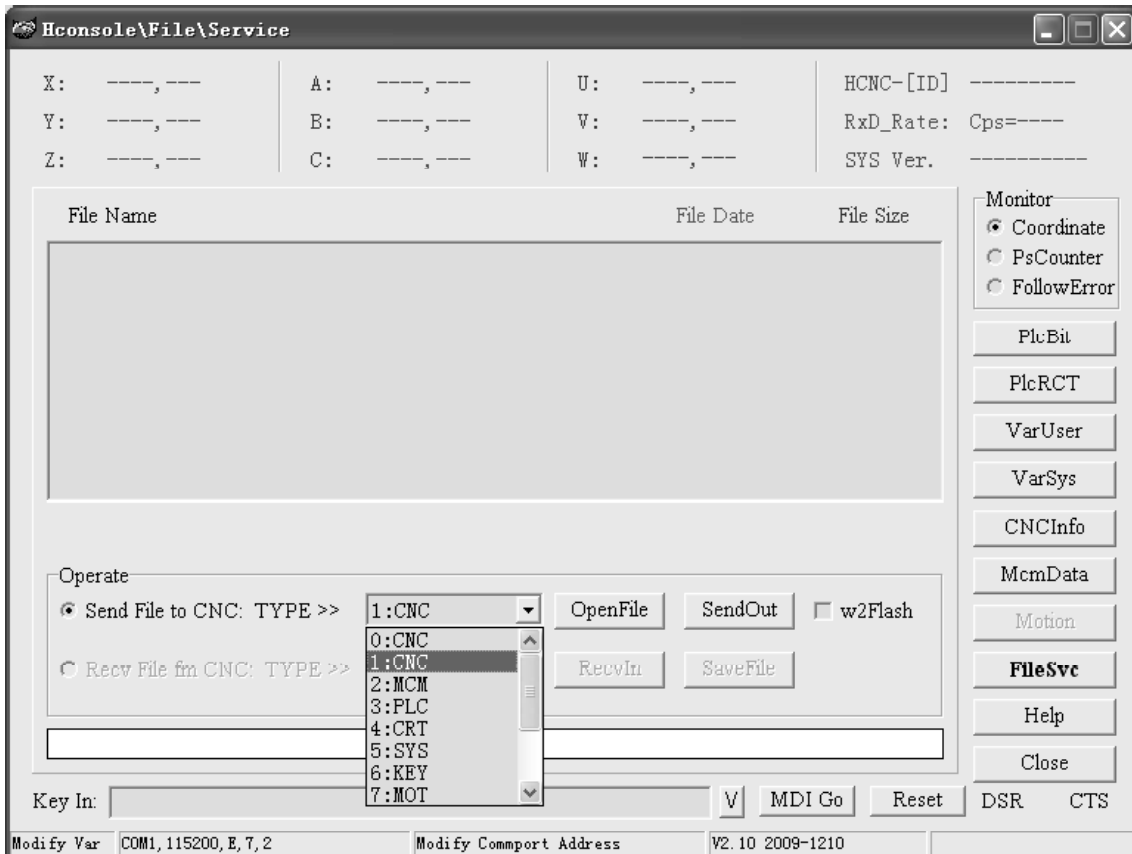

Fig 9-1

Note: If the transmission program has numbers, it will be stored as the same numbers as in CNC after transmitting, otherwise, it will be replaced by its current program.

1. The HCON is used to **【Upload】** the program data onto the controller, and the program data are stored on the memory cache (RAM).
2. When the controller turns the power off, the program data are stored on the memory cache (RAM) via the battery mode.
3. To ensure permanent data storage on the memory cache (RAM), there is need to execute the command **G10 P600 L01** to store the **【Uploaded】** program data onto the FLASHROM.
4. As depicted in Fig. 9-1, upon entering the G10 P600 L01 command in the entry area, press MDI Go to complete the burn movement.

9.1.2 Program Transfer from CNC Controller to PC

Movement program:

1. The controller is not in a program execution status (where S080=0).
2. On PC side, make sure the transmission is ready to transmit.
Baud Rate should be correct when you execute HCON.exe (See section 10, Chapter 9). After entering Data Transmission Mode (**FileSvc**),
(1) Select “ Recv File fm CNC : TYPE >>>> ”

- (2) Select “ 0:CNC ” to read the current program in the controller.
Select “ 1:CNC ALL” to read the full program in the controller.
- (3) Press “ **Recv In** ”
- (4) After the confirmation of the file content, press “ **Save File** ”

Note:

When the program is in execution (S080=1), you must stop for S080 turning “0” to re-operate the step 3 & 4.

Format for MCM Data Transfer:

| | |
|---------|---|
| % | |
| 09002 | Program number 9002 designated for MCM data |
| 0000000 | MCM #1 |
| 0000000 | MCM #2 |
| 0000000 | MCM #3 |
| 0000000 | MCM #4 |
| | |
| | |
| % | |

Notes:

1. The MCM data must start and end with a symbol of %.
2. The transmission MCM parameter’s program number is fixed to 09002.
3. No decimal point for MCM data transferred. The unit is 1/1000th of a second for time and µm for length or speed. One line for one MCM data only (7-digit).
For example, HOME speed on X-axis = 2500.00, it’ll show 0250000 after transferred. Software limit on Y-axis = -9999.999 cm, it’ll show -9999999.

9.1.3 Transfer MCM Data from PC to CNC Controller

Movement program:

1. The controller is not in a program execution state (where S080 = 0).
2. On PC side, make sure the transmission is ready to transmit.
Baud Rate should be correct when you execute HCON.exe (See section 10, Chapter 9). After entering Data Transmission Mode (**FileSvc**),
 - (1) Select “ Send File To CNC : TYPE >>> ”
 - (2) Select “ 2:MCM ”
 - (3) Press “ **Open File** ” to select the part program file for transmission.
 - (4) After the confirmation of file, press “ **Send Out** ”. PC will download the data automatically.

Note:

1. The HCON is used to **Upload** the MCM parameter data onto the controller, and the MCM parameter data are stored on the memory cache (RAM).
2. When the controller turns the power off, the MCM parameter data are stored on the memory cache (RAM) via the battery mode.
3. To ensure permanent data storage on the memory cache (RAM), there is a need to

run the command **G10 P600 L02** to burn the **【Uploaded】** MCM parameter data onto the FLASHROM.

4. As depicted in Fig. 901, after entering the G10 P600 L02 command in the entry area, press MDIGo to complete the burn movement.

9.1.4 Transfer MCM Data from CNC Controller to PC

Movement program:

1. The controller is not in a program execution state (where S080=0).
2. When S080 is “ 0 ”, the controller is stand-by.
3. On PC side, make sure the transmission is ready to transmit.
Baud Rate should be correct when you execute HCON.exe (See section 10, Chapter 9). After entering Data Transmission Mode (**FileSvc**),
 - (1) Select “ Recv File fm CNC : TYPE >>> ”
 - (2) Select “ 2:MCM ”
 - (3) Press “ **Recv In** ”
 - (4) After the confirmation of the file content, press “ **Save File** ”

Note:

When the program is in execution (S080=1), you must stop for S080 turning “0” to re-operate the step 3 & 4.

9.1.5 Transfer Data Variable from PC to CNC controller

Movement program:

1. The controller is not in a program execution state (where S080=0).
2. On the PC end, verify that the PC computer end is ready to carry out the program transmitting movement.
Execute HCON.exe to ascertain that there is no error in the communication protocol
Upon entering the data transmission mode (**FileSvc**),
 - (1) Select “Send File To CNC : TYPE >>> ”
 - (2) Select “ 9:Var ” (Transmitting the variable data to the controller).
 - (3) Press “ **Open File** ” to select the variable file to be transmitted.
 - (4) Upon ascertaining the file content, press **Send Out** .
The computer automatically uploads the data.

Caution: When the controller is running program (where S080=10, there is a need to wait for the program execution to stop (where S080=0) before running steps (3) & (4).

9.1.6 Transfer Data Variable from CNC controller to PC

Movement program:

1. The controller is not in a program execution state (where S080 = 0).

2. Execute HCON.exe (Refer to the chapter's section 10) to ascertain that there is no error in the communications protocol.

Upon entering the data transmission mode (**FileSvc**),

- (1) Select “Recv File fm CNC : TYPE >>> ”
- (2) Select 9 : Var 0~99 (Retrieve 99 variables)
 Or A : Var 0~199
 Or B : Var 0~299

 Or Q : Var 0~8999
 Or R : Var 0~9999 (Retrieve 9999 variables)
- (3) Press “ **Recv In** ”
- (4) Upon ascertaining the file content, press **Save File** to store the file name for the file to be saved.

Caution: When the controller is running programs (where S080=1), there is a need to wait for the program execution to stop (where S080=0) before running steps (3) & (4).

9.1.7 Transfer PLC Ladder from PC to CNC controller

Movement program:

1. The controller is not in a program execution state (where S080 = 0).
2. On the PC end, verify that the PC computer end is ready to carry out the program transmitting movement.

Execute HCON.exe to ascertain that there is no error in the communication protocol

Upon entering the data transmission mode (**FileSvc**),

- (1) Select “Send File To CNC : TYPE >>> ”
- (2) Select “ 3:PLC ” (transmitting the PLC data to the controller)
- (3) Press “ **Open File** ” to select the PLC file to be transmitted.
- (4) There is a need to check “ w2FLASH ” to execute the burn movement.
- (5) Upon ascertaining the file content, press **Send Out** .
 The computer automatically uploads the data.

Caution:

1. When the controller is running programs (where S080=1), there is a need to wait for the program execution to stop (where S080=0) before running step (5).
2. If step (4) “w2FLASH” movement has not been executed, then after uploading the data, there is a need to execute the MDI (G10 P600 L3) burn command, or else when the controller turns off the power, and at the startup, the system uploads the PLC on the Flash-ROM to the memory cache.
3. Upon completing transmitting the PLC file, make sure that the screen is prompted with “Data Loading Ok!”, otherwise it indicates that the PLC file has not been transmitted successfully.

9.1.8 Transfer LCD Screen Display Data from PC to CNC

Movement program:

1. The controller is not in a program execution state (where S080 = 0).
2. On the PC end, verify that the PC computer end is ready to carry out the program transmitting movement.

Execute HCON.exe to ascertain that there is no error in the communications protocol.

Upon entering the data transmission mode (),

- (1) Select “Send File To CNC : TYPE >>> ”
- (2) Select “ 4:CRT ” (Transmitting the screen data to the controller)
- (3) Press “ ” to select the screen file to be transmitted.
- (4) Upon ascertaining the file content, press .
The computer automatically uploads the data.

Caution:

1. When the controller is running programs (where S080=1), there is a need to wait for the program execution to stop (where S080=0) before running steps (4).
2. After uploading the screen data, there is no need to execute the burn command, as the system automatically uploads the data onto the Flash-ROM.

9.1.9 Transfer Controller System Data from PC to CNC

Movement program:

1. The controller is not in a program execution state (where S 080 = 0).
2. On the PC end, verify that the PC computer end is ready to carry out the program transmitting movement.

Execute HCON.exe to ascertain that there is no error in the communication protocol.

Upon entering the data transmission mode (),

- (1) Select “Send File To CNC : TYPE >>> ”
- (2) Select “ 5:SYS ” (Transmitting the system data to the controller)
- (3) Press “ ” to select the system file to be transmitted.
- (4) There is a need to check “ w2FLASH ” to activate the burn motion.
- (5) Upon ascertaining the file content, press .
The computer automatically uploads the data.

Caution:

1. When the controller is running programs (where S080=10, there is a need to wait for the program execution to stop (where S080=0) before running step (5).
2. Upon uploading the system data, there is no need to execute the burn command, as the system automatically uploads the data onto the Flash-ROM.
3. Upon completing transmitting the system file, make sure that the screen is prompted with “Data Loading Ok!”, otherwise it indicates that the system file has not been transmitted successfully.

9.1.10 Transfer function tables from PC to CNC controller

Movement program:

1. The controller is not in a program execution state (where S080 = 0).
2. On the PC end, verify that the PC computer end is ready to carry out the program transmitting movement.

Execute HCON.exe to ascertain that there is no error in the communication protocol.

Upon entering the data transmission mode (),

- (1) Select “Send File To CNC : TYPE >>> ”
- (2) Select “ 8:PTN ” (Transmitting the entry column data to the controller).
- (3) Press “ ” to choose the entry column file to be transmitted.
- (4) Upon ascertaining the file content, press .
The computer automatically uploads the data.

Caution:

1. When the controller is running programs (where S080=1), there is a need to wait for the program execution to stop (where S080=0) before running steps (4).
2. Upon uploading the screen data, there is no need to execute the burn command, as the system automatically uploads the data onto the Flash-ROM.

9.1.11 PC to Controller (ARM)

Movement program:

1. The controller is not in a program execution state (where S080 = 0).
2. On the PC end, verify that the PC computer end is ready to carry out the program transmitting movement.
3. Execute HCON.exe to ascertain that there is no error in the communications protocol
4. Upon entering the data transmission mode (),

- (1) Select “Send File To CNC : TYPE >>> ”
- (2) Select “ C:ARM ” (Transmitting the CPU data to the controller)
- (3) Press “ ” and choose the CPU file to be transmitted.
- (4) After verifying the file content, press .
The computer automatically uploads the data.

Caution:

1. When the controller is running programs (where S080=1), there is a need to wait for the program execution to stop (where S080=0) before running step (5).
2. Upon uploading the ARM data, there is a need to restart the computer in order to operate the system normally.

9.1.12 HCON.EXE Program Operation

Program Display:

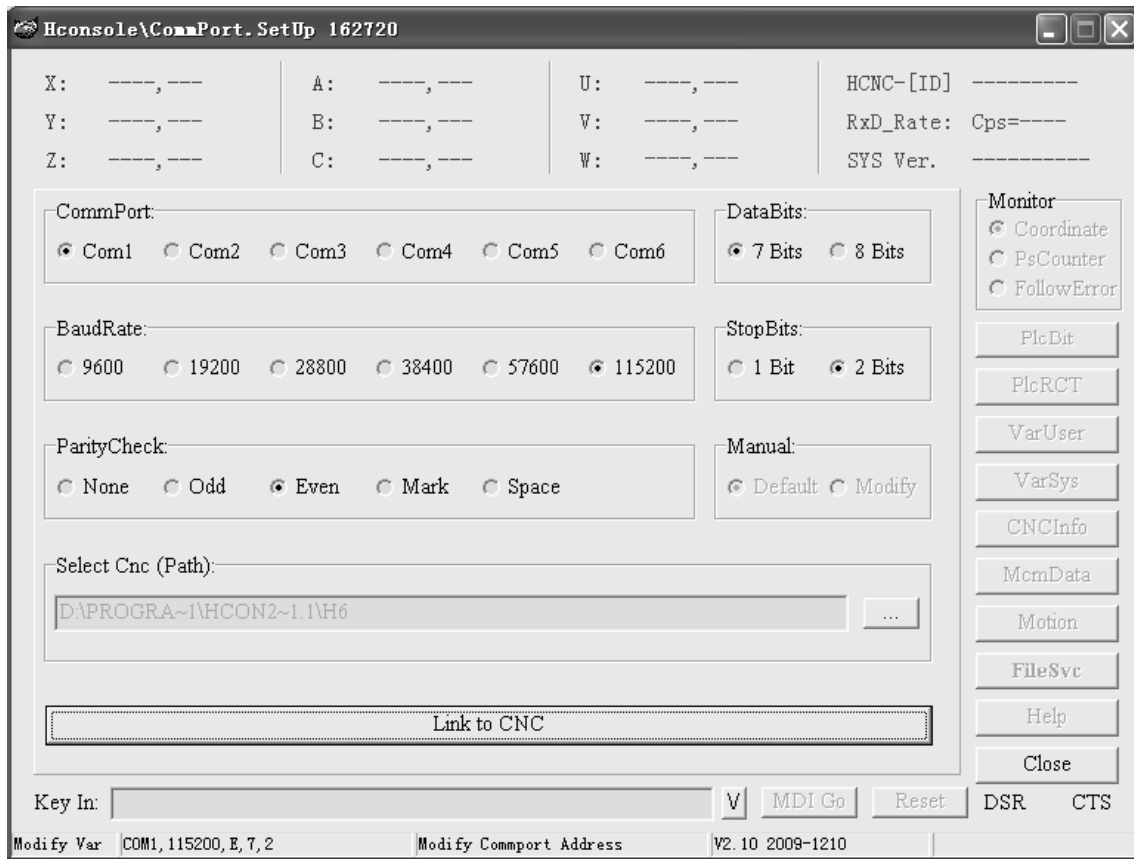

Fig 9-2

Note:

1. Baud rate must be kept the same like the MCM# 520 setting in the controller from CommPort Rs232 connectors.
2. Parity Check with H6D-T stays permanently as Even
3. Data Bit with H6D-T stays permanently as 7 Bits
4. Stop Bit with H6D-T stays permanently 2 Bits.

After the above 4 items are confirmed, please click “Link to CNC” to enter the software operation interface.

If the communication between the PC and the controller is normal, Cps is a non-zero value.

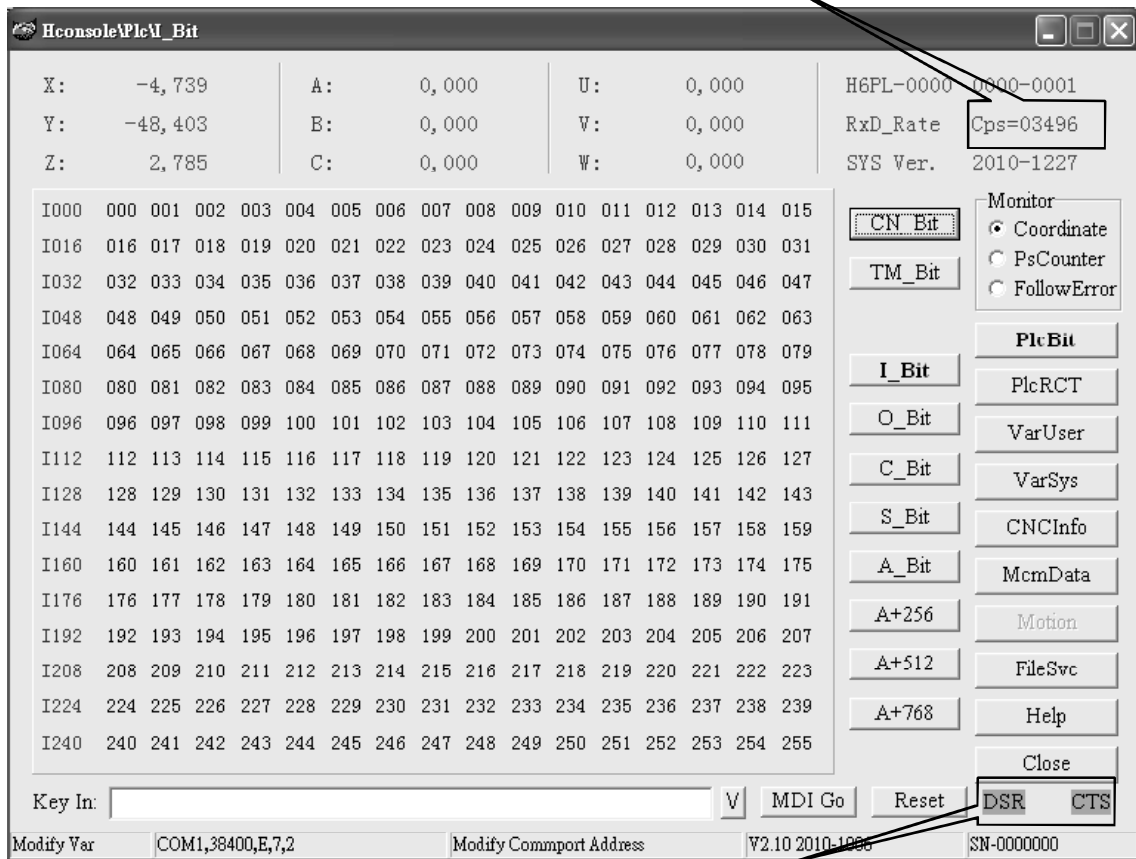

When the communication between the PC and the controller is normal, the DSR and CTS will be highlighted in red background.

Fig 9-3

Key Descriptions

- PlcBit : Signal I/O/C/S/A status display
- VarUser : Variables 0~9999 display
- Var Sys : Variables 10000~ 13999 display
- CncInfo : Particular variables system 10900~10999 display
- McmData : MCM parameters display
- Motion : Preserved
- FileSvc : Data Transmission (* Note 1)
- MDIgo : Enter Single Block command in the message box and press the key.
- ReSet : Reset the controller

* Note : The functions of File Svc is as follows:

- ⊙ Recv File fm CNC..... Read data from CNC
- ⊙ Send File to CNC:..... Transfer PC to CNC

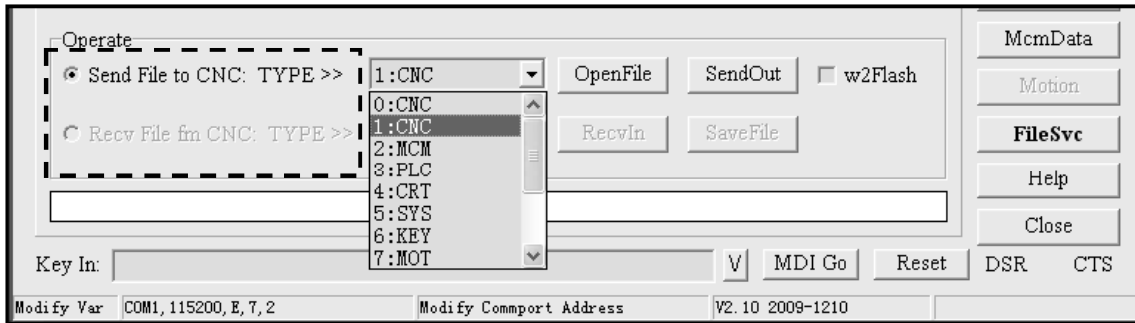

Fig 9-4

1. Recv File fm CNC : Read data from CNC

Recv File fm CNC:TYPE >>

- 0 : CNC PC read the main program.
- 1 : CNC_ALL PC read the full program.
- 2 : MCM PC read the parameters.
- 9 : Var-0099 PC read MCM#0~99
- A : Var-0199 PC read MCM# 0~199
- ◊ ◊ ◊ ◊ ◊
- Q : Var-8999 PC ead MCM#0~8999
- R : Var-9999 PC ead MCM#0~9999

- A. On PC side, select data in CNC and press “Recv In”, PC will start reading the data and storing them in memories temporarily.
- B. Press “Save File” and enter the file’s name. The action is complete.

2. Send File to CNC : Transfer PC to CNC

Send File to CNC: TYPE >>

- 0 : CNC PC transfer the part program to CNC.
- 1 : CNC PC transfer the part program to CNC.
- 2 : MCM PC transfer the parameter to CNC.
- 3 : PLC PC transfer PLC to CNC.
- 4 : CRT PC transfer self-editing screen to CNC.
- 5 : SYS PC transfer main system to CNC.
- 8 : PTN PC Transfer function tables to CNC.
- 9 : VAR PC Transfer user’s variable to CNC controller.
- A : CYF Reserved for special designated servos.
- B : 999 Reserved for special designated servos.
- C : ARM PC Transfer ARM data to CNC controller.

- A. After selecting the items, press “**Open File**” ; enter the desired file’s name.
- B. Wait for PC to complete the reading and store in the memories; press “**Send Out**” , the action is complete.
- C. **V** W2Flash shows that the data has been automatically burnt into Flash-Rom after being sent out.

9.1.13 RS232C Connection

A proper connection between PC and HUST controller is shown in Fig 9-5. Please refer to Connecting Manual for more information. When making connection, please be aware of the followings:

1. The connecting cable should not exceed 15 meters to minimize the potential noise interference. The voltage at the PC interface should be in the range of 10~15 volts.
2. Avoid working in an environment where is under the direct noise interference from the machines such as EDM, electric welder, etc. Do not use the same power outlet as for EDM and electric welder. Twisting the cable may help in noise reduction.

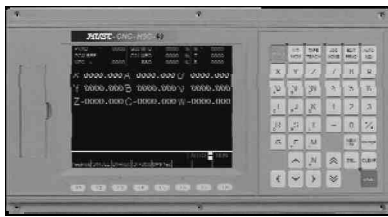

HUST CNC



PC COM2

DB9LM
CONNECTOR

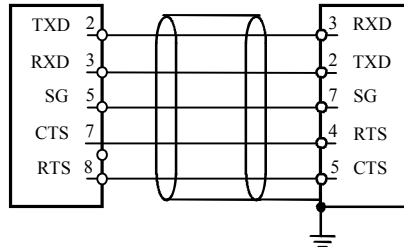

DB25LF
CONNECTOR

HUST CNC

PC COM1

DB9LM
CONNECTOR

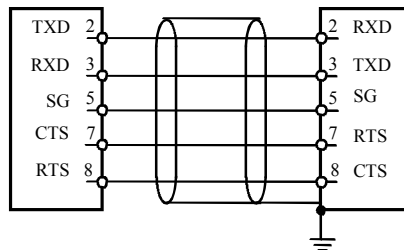

DB9LF
CONNECTOR

Fig 9-5 RS232 Connection

9.2 HUST H6D-T Transmission Modes

HUST H6D-T series controllers have the following four transmission modes for the user to select:

1. RS232 Mode
2. USB Device Mode (USB-H)
3. USB Host Mode (USB-D)
4. SDC Mode (SDC)

In JOG mode press the “File transfer” key for three seconds, it will enter the transmission mode selection screen as shown in Fig 9-6.

| | | | |
|-----------|-----------|-------------|------------------|
| PRNO: 000 | | CNT: 000000 | |
| ● X | -0000.000 | A | -000.00 |
| Y | -0000.000 | B | -000.00 |
| ● Z | -0000.000 | C | -000.00 |
| | | | |
| | | | |
| Back | | MDI | |
| Main | USB-H | SDC | USB-D TAPE RS232 |
| | | HOLD | |

Fig 9-6

The default is R232 Mode. The transmission mode can be switched by pressing the function keys.

※While switching the transmission mode, if a read error occurs:

1. Please press the “Reset” key.
2. Re-enter the transmission mode selection screen.
3. Switch to the R232 Mode to solve the problem.

9.3 USB Device Mode

PC and the H6D-T controller are connected via USB connection. Now, the H6D-T controller plays the role as the USB device side, i.e. a mobile diskette while PC plays the role as the USB host side. In this mode, PC can read data information such as user's programs, user's variables, machine parameters, etc. from the H6D-T controller. Also, PC can write its data in the controller.

9.4 USB Host Mode

In this mode, H6D-T plays the role as the USB host and can directly read / write data information such as system files, screen files, user's programs, user's variables, machine parameters, etc in a mobile diskette via the USB interface on the back of the controller. Also it can store the data in the mobile diskette from the controller.

9.5 Operational Instruction of A Standard H6D-T Transmission Interface

To select USH-H mode on the switch screen in the transmission mode, you shall enter the embedded transmission operation interface as shown in Fig 9-9.

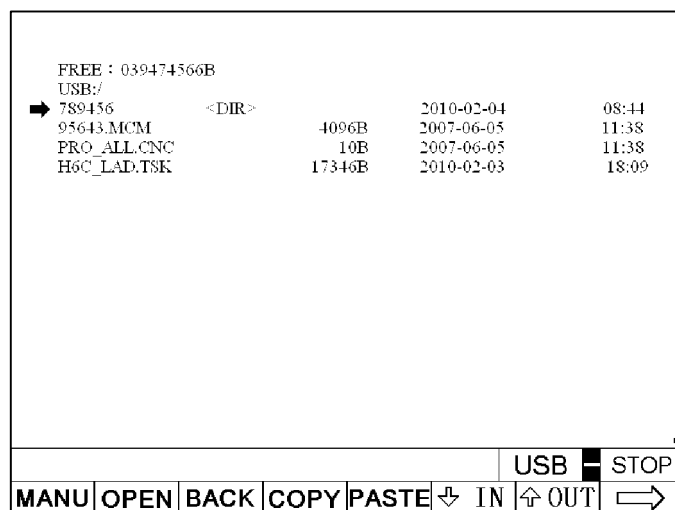

Fig 9-7

Descriptions of function keys:

Return to Main Menu: To switch back to the transmission mode screen.

Open a folder: To open the content of the data file stored on an USB or the controller's optional purchase of an expandable memory cache.

Return: Returns to the last level of directory.

Copy: Copies data.

Paste: Stores copied data.

EX : With directional keys \wedge \vee to move the cursor to the data file to be copied, press the COPY key and then press the PASTE key, you can create a new file.

Download: Goes to the file download interface.

Upload: Goes to the file upload interface.

→ : Goes to the second page in the transmission operating interface.

Press the function key→, you can enter the second page in the transmission operation interface as shown in Fig 9-8.

| | | | | | |
|-------------------|-------------|-------|--------|------------|----------|
| FREE : 039474566B | | | | | |
| USB:/ | | | | | |
| → | 789456 | <DIR> | | 2010-02-04 | 08:44 |
| | 95643.MCM | | 4096B | 2007-06-05 | 11:38 |
| | PRO_ALL.CNC | | 10B | 2007-06-05 | 11:38 |
| | H6C_LAD.TSK | | 17346B | 2010-02-03 | 18:09 |
| | | | | | 0 |
| | | | | | USB STOP |
| MANU | DEL. | RE-N | MAKE | ↕ IN | ↕ OUT ← |

Fig 9-8

Descriptions of function keys:

Return to Main Menu: To switch back to the transmission mode screen.

Delete: Deletes the file or folder the cursor is pointing at.

Rename: First key in a new file name and then press the function key, you can rename the file or folder the cursor is pointing at.

Add Folder: First key in the new folder name and then the function key, you can create a new folder.

Download: Goes to the file download interface.

Upload: Goes to the file upload interface.

← : Returns to the first page in the transmission operating interface.

9.5.1 File Download Interface

Press the function key **Download** on the transmission operating interface, you can enter the screen as shown in Fig 9-9 and 9-10.

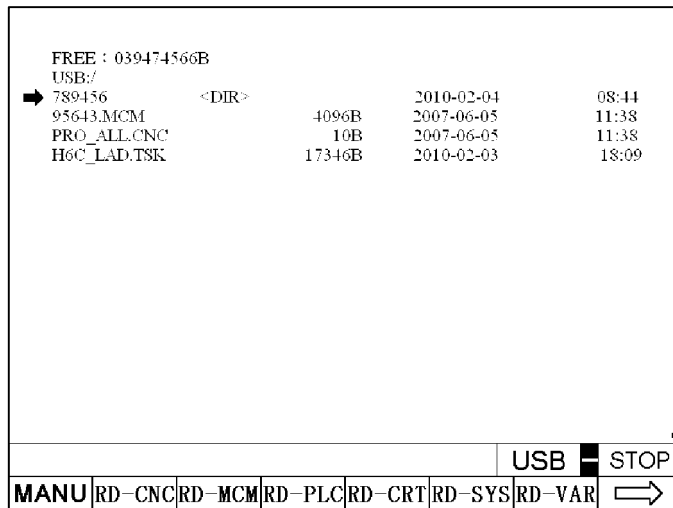

Fig 9-9

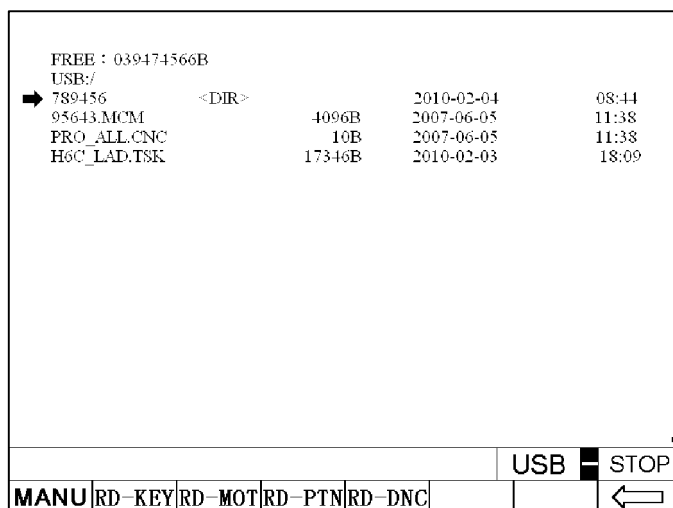

Fig 9-10

Download USB → CNC

Example: Steps for downloading a plc file are:

1. Press the **Download** function key to enter the download interface.
2. Go to the **PLC (*.PLC)** file using the cursor.
3. Press the **PLC** function key.
4. Check for any transmission indication appearing on the upper left corner of the screen.
5. After transmission, the screen will show “DATA LOADING OK”.

Note: To download data, first point the cursor to the file to be downloaded, and then press the desirable function key.

ZDNC Simultaneous Transfer/Execution:

※ Attention

1. If the file size of the machining program is too large, it is necessary to use the DNC feature for simultaneous "transfer and execution".
2. For the master-slave mode, the settings should be configured as non-stop mode for a single block (Parameter 501=256).
3. Set R127 to 8, and R128 to 32 (The recommended setting values).

Operation Procedure:

1. Use the arrow keys to select the machining program and then confirm.
2. Press the **RD-DNC** key to enter the DNC mode and the following screen will be displayed:
3. After the operation is completed, it will automatically return to the USB operation screen.
4. Trace function: During the operation, press the "S" button to enter the Trace mode.
5. Servo response: During the operation, press the "R" button to enter the servo response trace mode.
6. In the Trace mode, press the "AUTO" button to return to the AUTO mode screen.
7. The software key and trace operations are the same as the normal operation.

| | | | | | | | | |
|-------------------------|-----------|---------|-----------|----------|------|-------|-------------------------------------|------|
| PRNO : 0000 | | | | | | | | |
| X | -0000.000 | U | -0000.000 | MPG | X | 0000 | | |
| Y | -0000.000 | V | -0000.000 | G00 | MFO: | 0000% | | |
| Z | -0000.000 | W | -0000.000 | G01 | MFO: | 0000% | | |
| A | -0000.000 | | | SSO | : | 0000% | | |
| B | -0000.000 | | | M | : | 0000 | | |
| C | -0000.000 | | | T | : | 0000 | | |
| | | | | S | : | 0000 | | |
| N10 G0X0.Y0.Z0. | | | | | | | | |
| >N20 G1X4.577Y19.96F300 | | | | | | | | |
| N30 Z0.157 | | | | | | | | |
| | | | | | | TAPE | <input checked="" type="checkbox"/> | HOLD |
| Feed-Hold | SINGLE | Dry-Run | OP-Stop | MPG Test | | | | |

Fig 9-11

9.5.2 File Upload Interface

Press the **Upload** function key on the transmission operating interface, you can enter the screen as shown in Fig 9-12.

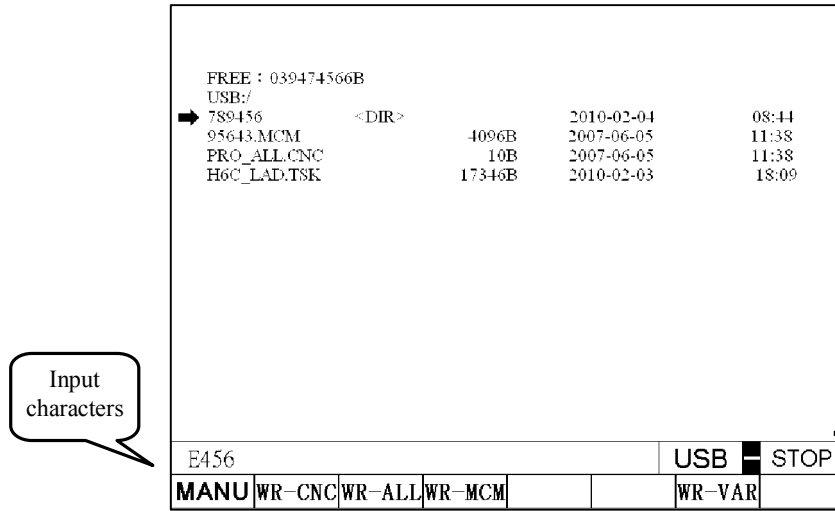

Fig 9-12

Upload CNC → USB(SD CARD)

Example: Steps for uploading a parameter are:

1. First key in the file name (letters+ numerals shall be no more than 8 bits). Key in **E456** and press **Enter**.
2. Press the **↑Parameter** function key.
3. After completion, you can see the E456.MCM file on the screen.

※ **To upload data, first key in the file name and then press the desirable function key.**

1.1 Appendix C Method for using the most often used G10 command

If the user wishes to alter the machine parameters, the program, and user variables when using the H6D-T controller, these operations can be achieved in the HCON interface or by using the G10 command in the MDI mode of the controller.

1.1 Operation Methods

There are two types of operation methods, one is in HCON interface and the other is in MDI mode.

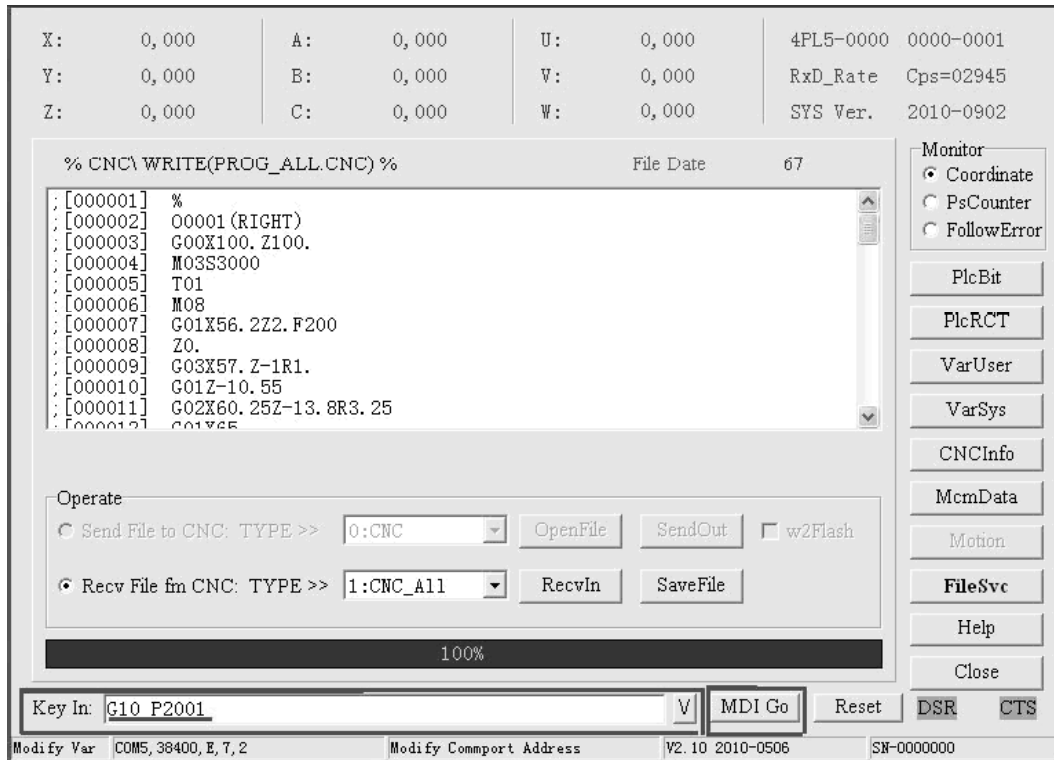

Fig.10-1

1.1.1 Operation in the HCON interface

- Make sure the HCON and H6D-T controller communicate with each other normally [see Appendix B for details].
- Key-in the command in the “Key In” box. E.g. “G10 P2001”.
- Click the “MDI Go” button.
- The command will be executed immediately.

2□ Operation in MDI mode

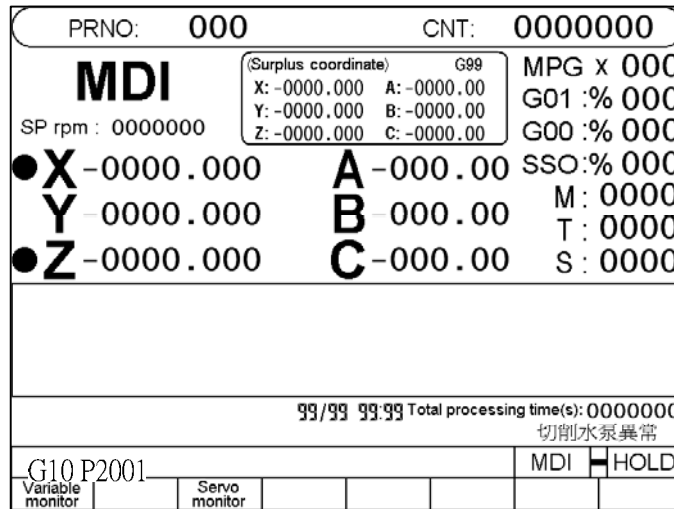

Fig.10-2

- Switch the H6D-T controller to MDI mode.
- Edit and key-in the command. E.g. □“G10 P2001”□ as shown in the above figure.
- Then press the “START” key.
- The command will be executed immediately.

2□ Operation of often used □1□Co□□ and

1□ G10 □□□□□□□□□□□□A□□□□B□□□□C□□□□□

□ou may use all the 6 axes simultaneously or any one of them selectively□by using the G10□set coordinates of workpiece origin □G54~G59□

The procedures are as follows:

- Execute manual homing to machine origin
 - Enter the MAN□AL mode
 - Move the tool □axially□to the work origin to be set.
 - Enter the MDI mode□key-in G54 and press the START key.
 - If the tool position in step 3 is the work origin to be set □set in G54□ then carry out the following actions:
 Press G10 □0. □0. □0. and ENTER
 START this completes the setting.
- e2. If the tool position in step 3 has a distance with the work origin to be set□ then carry out the following actions: □suppose this distance is □□20.□□□100.□□□15.□
 Press G10 □20. □100. □15. and ENTER
 START..... this completes the setting.

Take the following precautions when using G10 to set the work origin

- a. Do not add P when using G10 to set the work coordinates system or it will become a tool length (displacement) compensation.
- b. Use the same method to enter work coordinates system G55~G59. The difference is to replace G54 with G55~G59 in step 4. If any of the work coordinates system G54~G59 is not explicitly indicated in the steps, the work origin will be entered into the work coordinate system that is effective at that time.
- c. The G10 method can also be used to enter the work coordinates in a program.
- d. The machine coordinates of the origin of the G54~G59 work coordinates selected by the G10 method will be entered into MCM parameters [see 3.25]

3 G10 P600 L02 burning MCM parameters

E: If parameters are not burnt into FLASHROM after altering machine parameters or transmitting MCM parameters, you may press and hold the “Burn Parameter” key in the parameter screen to burn the parameters to the controller, you may alternatively edit and enter “G10 P600 L02” command in MDI mode, and then press the START key to complete the operation of Parameter Burning. The burning is successful when the controller screen shows the message “Data Loading Ok”.

3 G10 P600 L03 burn the PLC file

E: When using the HCON software to transmit a PLC file without check-selecting “W2Flash”, you may enter “G10 P600 L03” in the MDI mode upon completion of the transmission and then press the START key to complete the operation for burning the PLC. The burning is successful when the controller screen shows the message “Data Loading Ok”.

4 G10 P600 L05 burn the system file

E: When using the HCON software to transmit a system file without check-selecting “W2Flash”, you may enter “G10 P600 L05” in the MDI mode on completion of the transmission and then press START key to complete the operation for burning the PLC. The burning is successful when the controller screen shows the message “Data Loading Ok”.

5 G10 P1000: Loading parameters into memory from FLASHROM

E□: After replacing the main PCB of the controller□ insert the FLASHROM onto the new PCB and enter “G10 P1000” command in the MDI mode□then press START to save the parameters which are stored in the FLASHROM into the memory.

6□ G10 P2000: Delete the current program

E□: The current “Program No.” is: “No. 1 program”□entering “G10 P2000” in the MDI mode and pressing the START key will delete this No.1 program.

7□ G10 P2001: Delete all programs

E□: Edit and input “G10 P2001” in the MDI mode□then press START key to delete all the programs in the controller□including the 宏程式 □□□□ and user process programs.

This command can be used to delete all programs in the controller. Special cautions shall be taken when using this command since the operation is non-reversible. Please backup the program data and substitute program data before using this command.

8□ G10 P1999 L9999: clear the controller to return to default settings

E□1: In case of anomalies in screen display□parameter display□or machine operation after altering the controller data □compared to the status before the alteration□it is suggested to perform this command in the 2 ways as described above□and clear the controller to its default settings followed by re-loading the data.

E□2: In case of anomalies in user variables and machine parameters after linking with HCON software □the value becomes very large□or most of the values are identical□it is suggested to perform this command in the 2 ways as described above□and clear the controller to its default settings followed by re-loading the data.

Note□The above operations are non-reversible and shall be used □with □are□□u□est that □ou should □a□e □a□up and su□stitute data □efore perfor□in□the operation□

11 Appendix D Servo Motor Wiring

1. DELTA-A2 TYPE

Table 11-1

| HST 26pin M | | DELTA A2 50pin | | |
|-------------|------------|-----------------------------------|--------|------------|
| Pin No | Definition | Description | Pin No | Definition |
| 1 | /A | /A phase input | 22 | A- |
| 2 | A | A phase input | 21 | A |
| 3 | B | B phase input | 25 | B |
| 4 | /B | /B phase input | 23 | B- |
| 5 | | phase input | 50 | |
| 6 | / | / phase input | 24 | - |
| 7 | VCMD | 0~10V analog command | 42 | V-REF |
| 8 | GND | 5V GND V-command、Torgue 5V GND | 13 | GND |
| 9 | 5V | 5V Power | | |
| 10 | TOG | Torgue input | | |
| Servo-On | | | 9 | DI1- |
| | | | 45 | COM- |
| 17 | IN-49 | Group 2 Input signal | | |
| 18 | OT-49 | Group 2 Output signal | | |
| 19 | Pulse | Pulse command | 38 | Hpulse |
| 20 | Pulse- | Pulse command- | 29 | Hpulse- |
| 21 | Sign | Pulse Direction | 46 | Hsign |
| 22 | Sign- | Pulse Direction - | 40 | Hsign- |
| 23 | IN-48 | Group 1 Input signal | | |
| 24 | OT-48 | Group 1 Output signal | | |
| 25 | 24V | 24V Power | | |
| 26 | 24VGND | 24V GND、I/O 24V GND | | |

Parameters

P1-00 : External Pulse Input Type

- 0: AB phase pulse 4x□□□uadrature Input□
- 1: Clockwise □CW□□ Counterclockwise□CCW□pulse
- 2: Pulse □ Direction

P1-01 : Control Mode

- 0: Position control mode.
- 2: Speed control mode.

DELTA Connector short circuit

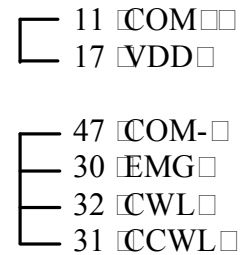

- P1-44 : Electronic Gear Ratio □1st Numerator□□N1□
- P1-45 : Electronic Gear Ratio □Denominator□□M□

Ex:

Encoder resolution 1280000 p/rev

P1-44□128

P1-45□1

1280000□f1 □128/1

F1□10000

P1-46: Encoder Output Pulse Number

This parameter is used to set the pulse numbers of encoder outputs per motor revolution.
value□2500

Note : The cable line must used with isolated twisted.
The servo brand's wiring are not the same□please refer to each servo wiring manual.

2. DELTA-B2 T□PE

Table 11-2

| H□ST 26pin □M□ | | | DELTA B2 44pin | |
|----------------|------------|--|----------------|------------|
| Pin No | Definition | Description | Pin No | Definition |
| 1 | /A | /A phase input | 22 | A- |
| 2 | A | A phase input | 21 | A□ |
| 3 | B | B phase input | 25 | B□ |
| 4 | /B | /B phase input | 23 | B- |
| 5 | □ | □ phase input | 13 | □□ |
| 6 | /□ | /□ phase input | 24 | □- |
| 7 | VCMD | 0~10V analog command | 20 | V-REF |
| 8 | GND | 5V GND □V-command、Torgue □ □5V GND□ | 19 | GND |
| 9 | 5V | □5V Power | | |
| 10 | TOG | Torgue input | | |
| Servo-On | | | 9 | DI1- |
| | | | 45 | COM- |
| 17 | IN-49 | Group 2 Input signal | | |
| 18 | O□T-49 | Group 2 Output signal | | |
| 19 | Pulse□ | Pulse command□ | 43 | Hpulse□ |
| 20 | Pulse- | Pulse command- | 41 | Hpulse- |
| 21 | Sign□ | Pulse Direction□ | 39 | Hsign□ |
| 22 | Sign- | Pulse Direction - | 37 | Hsign- |
| 23 | IN-48 | Group 1 Input signal | | |
| 24 | O□T-48 | Group 1 Output signal | | |
| 25 | 24V | □24V Power | | |
| 26 | 24VGND | 24V GND、I/O □ □24V GND | | |

Parameters

P1-00 : External Pulse Input Type

- 0: AB phase pulse 4x□□□uadrature Input□
- 1: Clockwise □CW□□ Counterclockwise□CCW□pulse
- 2: Pulse □ Direction

P1-01 : Control Mode

- 0: Position control mode.
- 2: Speed control mode.

- P1-44 : Electronic Gear Ratio □1st Numerator□□N1□
- P1-45 : Electronic Gear Ratio □Denominator□□M□

DELTA Connector short circuit

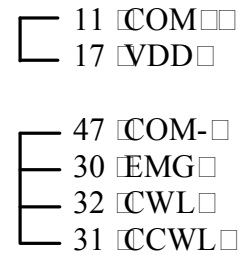

Ex:

Encoder resolution 1280000 p/rev

P1-44□128

P1-45□1

1280000□f1 □128/1

F1□10000

P1-46: Encoder Output Pulse Number

This parameter is used to set the pulse numbers of encoder outputs per motor revolution.
value□2500

Note : The cable line must used with isolated twisted.
The servo brand's wiring are not the same□please refer to each servo wiring manual.

3. MITSUBISHI J2

Table 11-3

| H□ST 26pin □M□ | | | CN1A | | CN1B | |
|----------------|------------|---|--------|------------|--------|------------|
| Pin No | Definition | Description | Pin No | Definition | Pin No | Definition |
| 1 | /A | /A phase input | 16 | LAR | | |
| 2 | A | A phase input | 6 | LA | | |
| 3 | B | B phase input | 7 | LB | | |
| 4 | /B | /B phase input | 17 | LBR | | |
| 5 | □ | □ phase input | 5 | L□ | | |
| 6 | /□ | /□ phase input | 15 | L□R | | |
| 7 | VCMD | 00~10V analog command | | | 2 | VC |
| 8 | GND | 5V GND □V-command、 Torgue □ □5V GND□ | | | 1 | LG |
| 9 | 5V | □5V Power | | | | |
| 10 | TOG | Torgue input | | | | |
| Servo-On | | | | | 5 | SON |
| | | | | | 10 | SG |
| 17 | IN-49 | Group 2 Input signal | | | | |
| 18 | O□T-49 | Group 2 Output signal | | | | |
| 19 | Pulse□ | Pulse command□ | 3 | pulse□ | | |
| 20 | Pulse- | Pulse command - | 13 | pulse- | | |
| 21 | Sign□ | Pulse Direction□ | 2 | sign□ | | |
| 22 | Sign- | Pulse Direction - | 12 | sign- | | |
| 23 | IN-48 | Group 1 Input signal | | | | |
| 24 | O□T-48 | Group 1 Output signal | | | | |
| 25 | 24V | □24V Power | | | | |
| 26 | 24VGND | 24V GND I/O □ □24V GND | | | | |

MITSUBISHI Connector short circuit

- 03 VCD CN1B
- 13 COM CN1B
- 15 EM-STOP CN1B
- 16 CW Limit CN1B
- 17 CCW Limit CN1B
- 20 SG CN1B

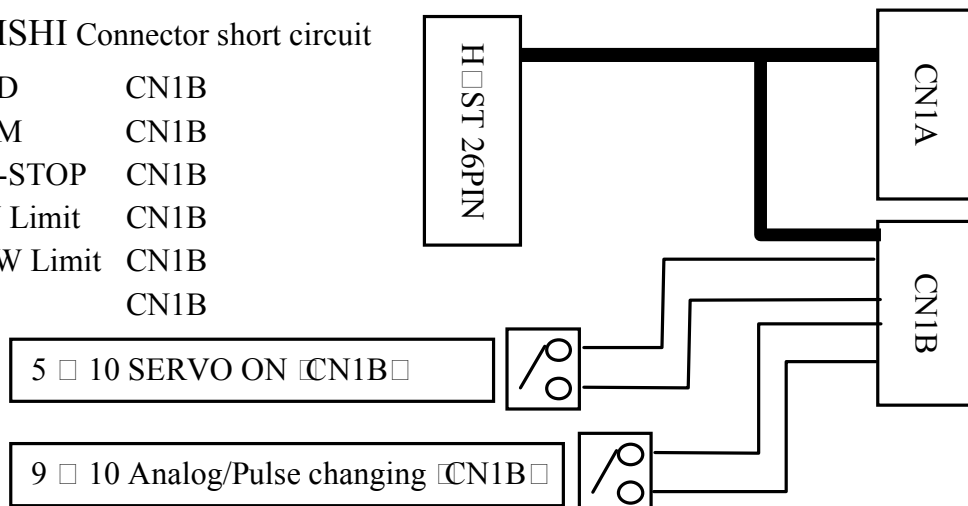

Parameters

P0 : Control Mode

- 0: Position control mode.
- 2: Speed control mode.

P3 : Electronic Gear Ratio □1st Numerator□□CM□□

P4 : Electronic Gear Ratio □Denominator□□CDV□

Ex:

Encoder resolution 131072 p/rev

P3 □16

P4 □1

131072 □f1 □16/1

F1 □8192

P21 : External Pulse Input Type

0: Clockwise □CW□□ Counterclockwise □CCW□ pulse

1: Pulse □ Direction

2: AB phase pulse □4x□□□uadrature Input□

P27: Encoder Output Pulse Number

This parameter is used to set the pulse numbers of encoder outputs per motor revolution.

value □10000 □x4 □

Note : The cable line must used with isolated twisted.

The servo brand's wiring are not the same □please refer to each servo wiring manual.

DELTA Connector short circuit

□ 11 □COM□□
□ 17 □VDD□

□ 47 □COM-□
□ 30 □EMG□
□ 32 □CWL□
□ 31 □CCWL□