

GXL SERIES

- Related Information
- General terms and conditions..... F-7
 - Sensor selection guide P.803~
 - Glossary of terms..... P.1482~
 - General precautions P.1485~

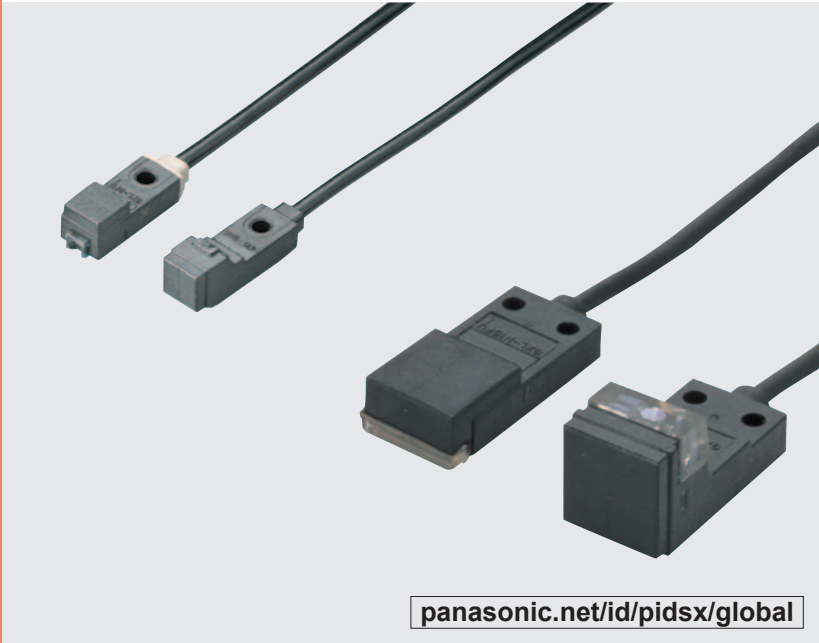

panasonic.net/id/pidsx/global

- 2-wire type available
- IP67G Oil resistant
- Flexible cable type available
- Different freq. type available

High performance in micro-size design

BASIC PERFORMANCE

Versatile mounting

Since the sensor is fingertip size, it can be mounted in a tight space.

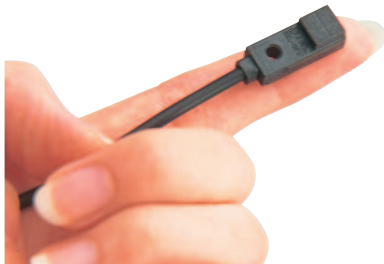

Reduced wiring operation

The wiring cost of the DC 2-wire type is 2/3 that of a conventional model. Besides, the possibility of miswiring is reduced.

Particularly convenient when many sensors are used.

Wiring of the 3-wire type is cumbersome.

Wiring of the 2-wire type is simple and neat.

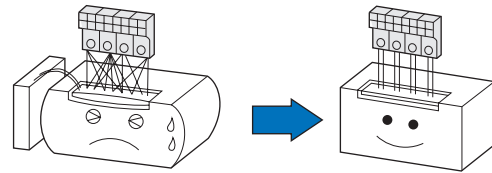

ENVIRONMENTAL RESISTANCE

Flexible cable type

The bending durability of its cable is ten times that of the conventional model. The sensor can be mounted on a moving table or a robot arm.

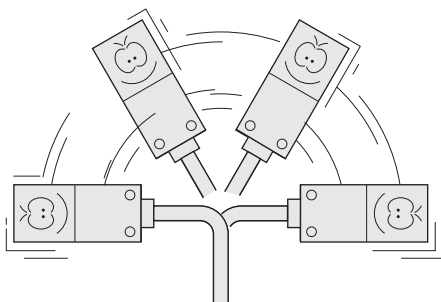

Others

Cost performance

Achieve high performance at an affordable price.

- FIBER SENSORS
- LASER SENSORS
- PHOTOELECTRIC SENSORS
- MICRO PHOTOELECTRIC SENSORS
- AREA SENSORS
- LIGHT CURTAINS / SAFETY COMPONENTS
- PRESSURE / FLOW SENSORS
- INDUCTIVE PROXIMITY SENSORS**
- PARTICULAR USE SENSORS
- SENSOR OPTIONS
- SIMPLE WIRE-SAVING UNITS
- WIRE-SAVING SYSTEMS
- MEASUREMENT SENSORS
- STATIC ELECTRICITY PREVENTION DEVICES
- LASER MARKERS
- PLC
- HUMAN MACHINE INTERFACES
- ENERGY CONSUMPTION VISUALIZATION COMPONENTS
- FA COMPONENTS
- MACHINE VISION SYSTEMS
- UV CURING SYSTEMS

- Selection Guide
- Amplifier Built-in
- Amplifier-separated
- GX-F/H
- GXL**
- GL
- GX-M
- GX-U/GX-FU/GX-N
- GX

APPLICATIONS

Detecting wafer frame

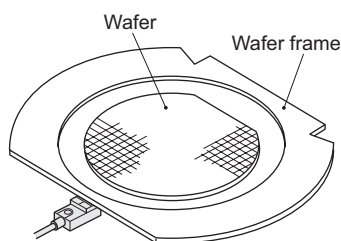

Detecting aluminum pallet

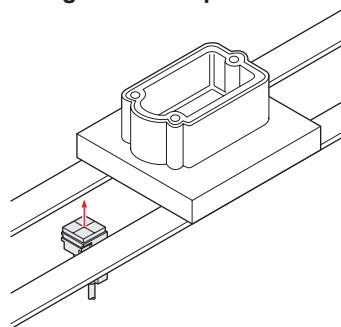

Code reading

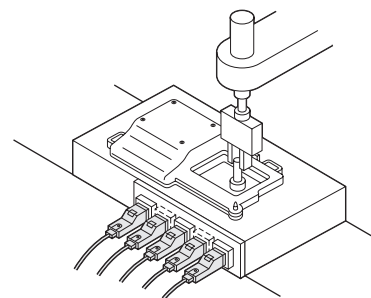

ORDER GUIDE

GXL-8 type

Type	Appearance (mm in)	Sensing range (Note 1)	Model No. (Note 2)	Output	Output operation
DC 2-wire			GXL-8FU	Non-contact DC 2- wire type	Normally open
			GXL-8FUI		
			GXL-8FUB		Normally closed
			GXL-8FUIB		
			GXL-8HU		Normally open
			GXL-8HUI		
			GXL-8HUB		Normally closed
			GXL-8HUIB		

Notes: 1) The maximum operation distance stands for the maximum distance for which the sensor can detect the standard sensing object. The stable sensing range stands for the sensing range for which the sensor can stably detect the standard sensing object even if there is an ambient temperature drift and/or supply voltage fluctuation.
 2) " I " in the model No. indicates a different frequency type.

GXL-15 (Standard) type

Type	Appearance (mm in)	Sensing range (Note 1)	Model No. (Note 2)	Output	Output operation
DC 2-wire			GXL-15FU	Non-contact DC 2- wire type	Normally open
			GXL-15FUI		
			GXL-15FUB		Normally closed
			GXL-15FUIB		
			GXL-15HU		Normally open
			GXL-15HUI		
			GXL-15HUB		Normally closed
			GXL-15HUIB		

Notes: 1) The maximum operation distance stands for the maximum distance for which the sensor can detect the standard sensing object. The stable sensing range stands for the sensing range for which the sensor can stably detect the standard sensing object even if there is an ambient temperature drift and/or supply voltage fluctuation.
 2) " I " in the model No. indicates a different frequency type.

- FIBER SENSORS
- LASER SENSORS
- PHOTO-ELECTRIC SENSORS
- MICRO PHOTO-ELECTRIC SENSORS
- AREA SENSORS
- LIGHT CURTAINS / SAFETY COMPONENTS
- PRESSURE / FLOW SENSORS
- INDUCTIVE PROXIMITY SENSORS**
- PARTICULAR USE SENSORS
- SENSOR OPTIONS
- SIMPLE WIRE-SAVING UNITS
- WIRE-SAVING SYSTEMS
- MEASUREMENT SENSORS
- STATIC ELECTRICITY PREVENTION DEVICES
- LASER MARKERS
- PLC
- HUMAN MACHINE INTERFACES
- ENERGY CONSUMPTION VISUALIZATION COMPONENTS
- FA COMPONENTS
- MACHINE VISION SYSTEMS
- UV CURING SYSTEMS

- Selection Guide
- Amplifier Built-in
- Amplifier-separated
- GX-F/H**
- GXL**
- GL**
- GX-M**
- GX-U/GX-FU/GX-N
- GX**