

Operating Instructions

Cutting on the fly - Control

- Supplement to COMPAX-M / S - Standard Documentation -

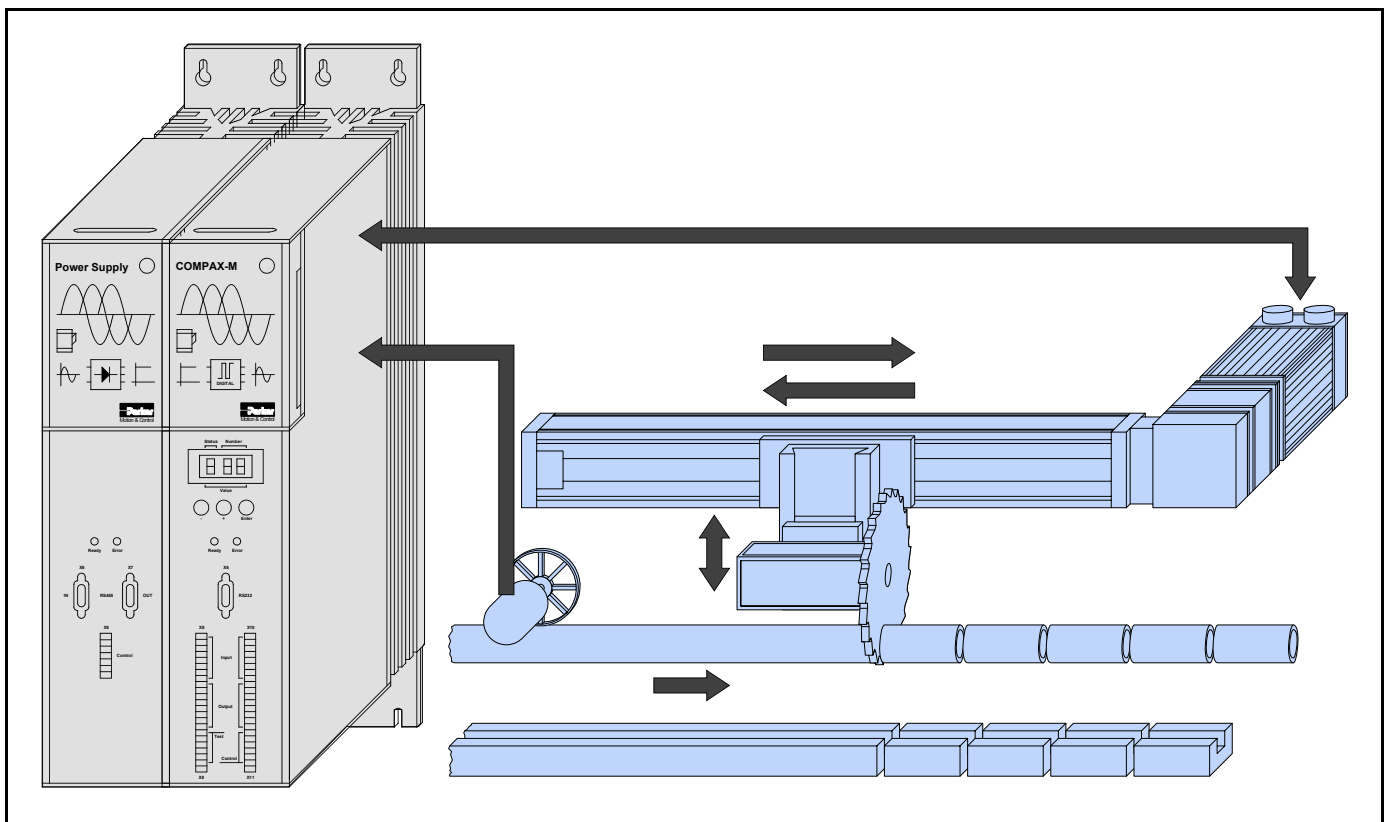

From software version 3.74

February 99

HAUSER
We automate motion



Parker Hannifin GmbH
EMD HAUSER
Postfach: 77607-1720
Robert-Bosch-Str. 22
D-77656 Offenburg, Germany
Tel.: +49 (0)781 509-0
Fax: +49 (0)781 509-176
<http://www.parker-emd.com>

Parker Hannifin plc
EMD Digiplan
21 Balena Close
Poole, Dorset
BH17 7 DX UK
Phone: +44 (0)1202 69 9000
Fax: +44 (0)1202 69 5750
<http://www.parker-emd.com>

Contents

1 Overview	2
2 Configuration	3
3 Cutting on the fly functions	3
3.1 Cutting on the fly commands	4
3.1.1 Synchronization with automatic return: WAIT POSA	4
3.1.2 Synchronization without automatic return: WAIT POSR	6
3.2 Label related synchronization	6
3.3 Diagonal-beam sawing	7
3.4 Waste length, chaff length	7
3.5 Head cut	7
3.6 Manual cut	7
3.7 Material simulation	8
4 Special inputs and outputs	8
4.1 Function of inputs	8
4.2 Function of outputs	8
5 Special status assignment	9
6 Analogue output	9
7 Encoder-interface	9
8 Cutting on the fly parameters	9

1 Overview

The cutting on the fly controller differs from the standard COMPAX-M/S standard device in the following features:

Required Op-tions:	Encoder input module E2 (with bus termination) or E4 (without bus interface for setting up an encoder bus).
Possible Operation modes:	Normal operation and endless operation. No speed control mode.
Acceptable drive types:	Like standard device
Mechanical reference system:	Like standard device
Additional commands:	WAIT POSA XXX Synchronization with automatic return. WAIT POSR XXX Synchronization without automatic return.
Locked commands:	SPEED SYNC • GOSUB EXT • GOTO EXT • Rapid start via I15
Modified commands:	Label related positioning standard device: related to the movement of axis. Switched on with I14="1" and P35="1". Command: POSR Cutting on the fly control: related to the movement of material. Switched on with I14="1". Command: WAIT POSA or WAIT POSR.
Modified I/O Functions:	I6: STOP has no effect during a synchronization process. I12: Material simulation I13: Manual cut I14: Enable label reference I15: End of synchronous travel I16: Label input O5: Position reached for synchronization commands (WAIT POSA, WAIT POSR) = "0"; at the start of the axis = "1": after the command. O14: Synchronous comparator O15: Waste length too small O16: Waste length
Modified parameters:	P30: Minimum distance to label P31: Position of label sensors related to the machine zero initiator P32: Relative target position P33: Synchronous comparator P34: Deceleration travel for synchronization P35: Acceleration travel for synchronization P36: Material simulation P37: Waste length P38: Correction of saw blade P39: Angle of beam
Modified status:	S41: Speed of material S42: Length of material S45: Acceleration travel for synchronization
Miscellaneous:	With option D/A- Monitor (D1) cutting length and speed of material are given as analogue value related to 10 V.

This manual applies to the following devices:

- ◆ COMPAX 2550S
- ◆ COMPAX 4550S
- ◆ COMPAX 8550S
- ◆ COMPAX P150M
- ◆ COMPAX 0250M
- ◆ COMPAX 0550M
- ◆ COMPAX 1550M
- ◆ COMPAX 3550M

Code of device designation

COMPAX 0260M:

COMPAX: Name
02: Power class
60: Variant e.g. "00": standard device
M: Device type M: Multi-axis device
E: Single-axis device
...

HAUSER nameplate



option name _____ equipment name _____
serial number _____ part number _____

This manual is supplementary to the COMPAX User Guide.

2 Configuration

Compared with the configuration process of the standard operating instructions the following have to be noted for cutting on the fly control:

Possible operation modes	"Normal operation" and "endless operation" no rpm control operation
Ramp profile	acceleration to synchronous speed: only with linear profile otherwise: the set ramp form
Direction	positive direction of the linear axis = direction of the material feed forward

3 Cutting on the fly functions

Processing on the fly saw / shear, processing in motion

The saw carriage is mounted parallel to the material flow direction. It will be accelerated up to the speed of the processed material and then travels synchronous to the material speed. The relative speed between material and saw carriage adjusts to zero. When the synchronization is reached, it is indicated by COMPAX via the digital output. Now the cutting process will be executed by the movement of the cutting tool rectangularly to the material travel. Via a digital input, the synchronism will be terminated and the carriage will slow down. Then the carriage travels automatically (or defined from the user) back to the starting position. There, the saw waits until the material has traveled the distance according to the cutting length.

Diagonal-beam saw

The diagonal-beam saw is a special version of the cutting on the fly saw. Here the guidance of the saw (linear axis) is at a fixed angle above the processed material. The saw blade is rectangular to the material flow direction. When the saw moves, it results in a movement in the material flow direction dependent on the angle between the path of the saw and the material. The controller adjusts the speed of the saw in relation to the angle of beam thus it results in a synchronism between saw blade and material. The relative speed is zero. At the end of the cutting process the saw will be lifted and moved to a waiting position.

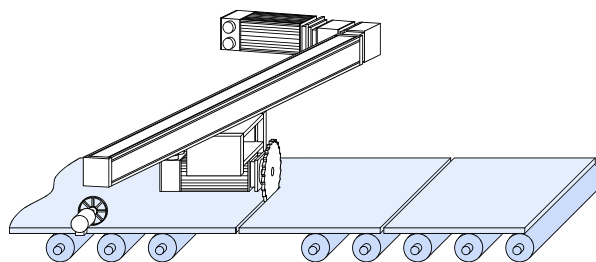

Label related processing

In some applications the measurement of the material feed forward is not required to operate continuously but is dependent on a label fixed on the material. The measurement of the length then begins when the label is detected and indicated via an input in COMPAX.

Waste length, chaff length

With increasing material speed, longer processing time or reduced cutting length, the time of the drive in waiting position gets shorter. The waiting time approximates towards zero, the control changes over to a substitute length, so-called "waste length". This situation is indicated by COMPAX via an output. If the waste length, which normally is larger than the normal cut, can not be activated then the control changes over to chaff operation. This is the minimum achievable cutting length.

Manual cut

When manual cutting, the synchronization is started directly from the wait position, the predefined material length is not considered.

Head cut - first processing

The first synchronization cycle after the START signal is treated specially.

Material - simulation

During the start up situation when, in general material is not yet available, it is possible to simulate the material speed via a parameter or a potentiometer (at the override input).

3.1 Cutting on the fly commands

	<p>A STOP is only effective at the end of a cut on the fly command.</p> <p>Exception: With the STOP the synchronization command will be stopped in waiting position (marker 8-9 in the illustration on the following page). A cut on the fly command can be interrupted with a BREAK.</p>
--	--

➡ Before interrupting the synchronization command, you have to drive to the idle position.

3.1.1 Synchronization with automatic return: WAIT POSA

command: WAIT POSA value

value: distance of processing (length of material for sawing)

figure with two number values after decimal point (three for inch) in [mm, inch]; or a user parameter (P40..P49) i.e. WAIT POSA .P40.

With WAIT POSA *value*, a complete synchronization process will be executed proceeding from the wait position of the control. This also includes the return; following the command, the drive waits in the initial start position.

Processing distance

With *value* in the synchronization command, the distance of processing (or the length of material) is pre-defined.

Procedure of a synchronization process

Acceleration to material speed (stage 1-2; next page)

The drive is stationary still in the idle position. Depending on the preferred length of material, the starting time is automatically calculated by COMPAX. There are two methods to define the acceleration of the material:

1. With the standard value for the acceleration time (time to accelerate to nominal speed) via the command ACCEL.

Set by P35=0.

Attributes:

- ◆ The specific requirement of acceleration travel length for synchronization is variable and calculated by COMPAX. It is dependent on the material speed.
 - ◆ The required acceleration moment is independent of the material speed.
2. With the standard value of a fixed acceleration distance for synchronization in parameter P35. This will be covered by the control during the acceleration stage.

Unit P35 in accordance with P90.

Set by P35>0.

Attributes:

- ◆ The acceleration distance for synchronization is constant.
- ◆ The needed acceleration moment increases with the material speed.

➡ With P35 = 0 it will be switched to the standard value of the acceleration time.

Start of processing (point 3)

Processing can be started with the binary output O14.

The synchronous comparator O14 will be set when

- ◆ the drive is synchronous with the material and
- ◆ in addition, the drive has covered the distance stated in P33 (synchronous comparator).

With parameter P33, the detrimental effect of an overshoot of the drive can be compensated by a delayed start of the process e.g. cutting drilling.

Processing time (stage 3-4)

The synchronous motion will be completed as follows:

- ◆ with a positive edge at the binary input I15 or
- ◆ when the limits of the linear axis will have been reached. This takes the potential braking distance into account.

Processing end (Point 4)

The behavior of COMPAX at the processing end can be influenced by parameter P32 (relative target position in units according to P90):

COMPAX travels after processing end (I15="1") to the following position:

Target position = Idle position (Start position) + P32

At P32=0 COMPAX therefore travels back to the same position (=Start position) (as shown by the bold line in the diagram).

Using P32≠0 a new start position can be set (relative to the old start position) for the next processing cycle. If the new start position is further than the processing end, the drive travels at the speed set by SPEED to the new target position (as shown with the dotted line in the diagram).

Limit supervision

The target position (Start position + P32) is checked for the limits (P11 and P12). If the target position is outside the limits, error E25 is triggered and the drive stopped at a controlled position, but is not switched off.

Automatic return (stage 4-8)

For the automatic return the following applies:

- ◆ the selected ramp profile and
- ◆ the speed selected via the SPEED command.

The acceleration and deceleration ramps are set via the "ACCEL-" command or via P34 (Synchronous deceleration travel). The following applies:

P34=0

The acceleration and deceleration ramps are defined by the command "ACCEL-".

P34>0

The deceleration time taken to decelerate from synchronous operation to null (stage 4-5) is calculated from the synchronous deceleration travel P34 and the actual speed (=Material speed).

Further reverse travel (stage 5-8) is implemented with acceleration and deceleration ramps defined by the command "ACCEL-".

Note!

The deceleration travel is not precisely maintained and therefore cannot be used as a label.

P34<0

If P34 has a negative specification, the deceleration time calculated (see P34>0) is also used for the reverse travel (stage 5-8).

➡ P34<0 only with WAIT POSA!

Idle position (stage 8-9)

Synchronous travel is ended at the idle position defined by P32. O5 "position reached" changes to "1".

Procedure:

1	Start from idle position with "WAIT POSA"
2	Acceleration to material speed
3	Processing start following travel P33.
4	Processing end; triggered by I15="1"

P32<Processing end

5	Deceleration to speed 0 with ACCEL- (when P34=0) or deceleration travel P34.
6	Acceleration to "SPEED" with ACCEL- or deceleration travel P34 (when P34 is negative).
7	Reverse travel with "SPEED" opposite to material direction.
8	Deceleration to 0 with ACCEL- or deceleration travel P34 (when P34 is negative).

P32>Processing end

5	Acceleration to "SPEED" with ACCEL- or deceleration travel P34 (when P34 is negative) Subsequently, travel at SPEED in material direction.
6	Deceleration to 0 with ACCEL- or deceleration travel P34 (when P34 is negative).
7	Idle position
8	Idle position
9	Start from idle position with "WAIT POSA/POSR"

Process of a synchronization cycle

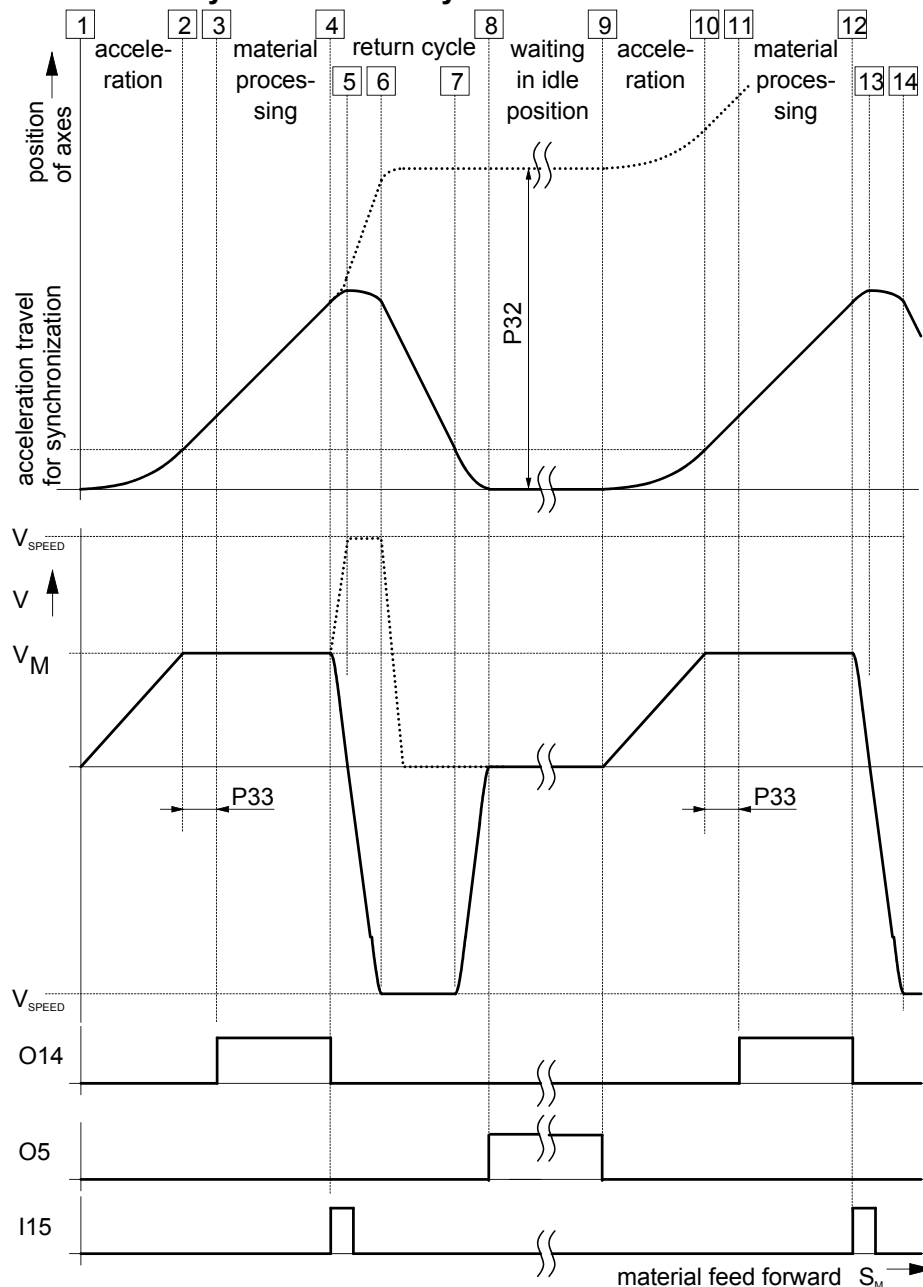

Saw blade correction P38

In P38, the reduction of length for a "cut on the fly saw" is entered to compensate for (blade thickness). This correction value is added to every cut length including the waste length.

➡ Parallel command process

During the return (stage 5-8; not stage 4-5), the commands following the synchronization command, will be executed up to the next positioning command.

Example for a program

N001: ACCEL 250	acceleration time and
N002: SPEED 80	speed to drive to the idle position.
N003: POSA 0	drive to the idle position.
N004: ACCEL 400	acceleration time for the acceleration travel for synchronization
N005: ACCEL- 200	acceleration time for the return
N006: SPEED 100	speed for the return
N007: WAIT POSA .P40	synchronization to the length memorized in P40.
N008: GOTO 7	repeat synchronization.

3.1.2 Synchronization without automatic return: WAIT POSR

Command: WAIT POSR *value*

value: Processing distance (the cutting length for sawing)

Value with two number values after decimal point (three for inch) in [mm, inch]; or an operating parameter (P40..P49) e.g. WAIT POSR .P40.

With WAIT POSR *value*, a synchronization process without automatic return is executed starting from an idle position of the drive. The drive slows down

- ◆ with a positive edge at the binary input I15 or
- ◆ if the end limits of the linear actuator would be reached after braking and stands still.

Otherwise, the description in chapter 3.1.1 is valid for the process of a synchronization with WAIT POSR.

➡ With WAIT POSR, P34=0!

3.2 Label related synchronization

Label related synchronization is switched on with input I14="1". A change of the signal at I14 will be registered

- ◆ with the first cut on the fly command, or
- ◆ with the signal I15 (ending of synchronization)

Label input is I16.

Label related synchronization is possible with and without automatic return and will start with the commands **WAIT POSA *value*** resp. **WAIT POSR *value*** as described earlier.

value: Point of processing relative to the recognized label position (length of material relative to the label for sawing)

For the synchronization process, the description in chapter 3.1.1 is valid. Note the following:

- ◆ With parameter **P30** "minimum distance to label", labels can be faded out.

Before accepting a label signal, the material has to travel the distance given in P30 beyond the last processing point.

➡ For the first cut (head cut) P30 will be disregarded.

- ◆ In parameter **P31**, the position of the label sensor is entered relative to the machine zero point of the linear actuator.

Processing on the fly

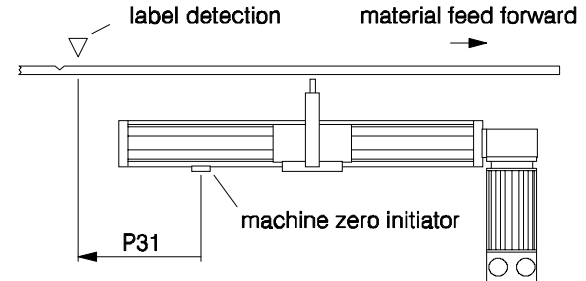

Diagonal-beam sawing

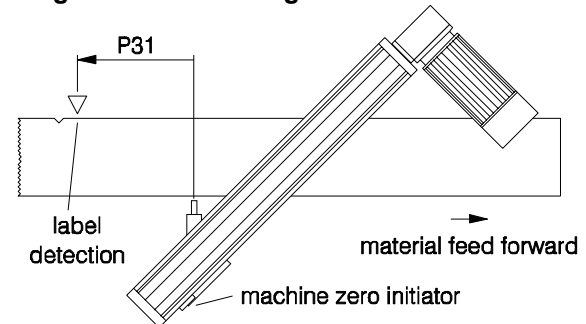

➡ In the depicted examples, P31 is negative.

- ◆ Label input **I16** is not detected in
 - ◆ the synchronous process and
 - ◆ during the acceleration to material speed.

3.3 Diagonal-beam sawing

The diagonal-beam sawing can be realized

- ◆ with and without automatic return
- ◆ with and without label reference.

Note the following points:

- ◆ Standard value of the angle of beam in parameter P39 (acute angle between the linear actuator and the material movement).
range: 0...80 degree.
- ◆ Constant acceleration travel for synchronization (standard value via P35 not via ACCEL) and
- ◆ Constant idle position, although the point of intersection with the material (beginning of saw cut) is defined exactly.

3.4 Waste length, chaff length

The waste length P37 is an alternative value and will be used if the required length can not be achieved. The minimum possible processing distance is the chaff length. i.e.:

Without label reference:

- ◆ **O16="1"**: The adjusted processing distance will be followed.

O16="0" and O15="1": processing distance = waste length.

O16="1" and O15="0": processing distance = chaff length.

For waste length P37 = 0

O16="0" and O15="0": The cutting length can not be followed:

- ◆ the drive stands still,
- ◆ the execution of the command line is interrupted.
- ◆ A new START (I5="1") is necessary.

with label reference:

➡ The adjusted waste length (P37) is measured from the last cut.

- ◆ **O16="1"**: The adjusted processing distance will be followed.

O16="0" and O15="1": processing distance = waste length, i.e. no label is recognized within the label window (see picture below).

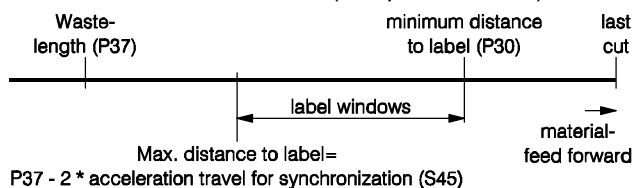

➡ By failure of a label, the synchronization proceeds as without label reference. Material length = waste length.

O16="1" and O15="0": processing distance = label position + chaff length; the length adjusted with *value* could not be followed.

Waste length (P37) = 0: synchronization only to label
Synchronization without maximum distance to label; the drive stands still, if there is no label.

If the length after label could not be followed:

- ◆ the drive stands still,
- ◆ the execution of the command line is interrupted.
- ◆ A new START (I5="1") is necessary.

This is signaled with: **O16="0" and O15="0"**.

➡ **O16="0" and O15="0"** can be acknowledged.

3.5 Head cut

Without label reference

The first synchronization cycle after the START signal (for WAIT START in the program or for the first program start) will be executed immediately, since the material length is not known.

With label reference

For label related synchronization the first synchronous point after a START signal (for WAIT START in the program or for the first program start) will move, label related, the adjusted minimum distance to the label is not in effect.

Direct command mode for WAIT POSA or WAIT POSR

A head cut during a synchronization command is effected:

- ◆ after drive to machine zero,
- ◆ after drive to real zero,
- ◆ after power on,
- ◆ after an error,
- ◆ after stop or
- ◆ after break.

3.6 Manual cut

The synchronization can be started immediately for an applied synchronization command (WAIT POSA or WAIT POSR) with input I13="1".

3.7 Material simulation

I12="1": material simulation is activated.

P36 Material speed in % of the nominal speed.

P36 = 0: Material speed is given via the override input.

	The override speed adjusted during the switch-over (I12="1") will be adopted as the speed of the axis. Therefore, adjust the override value to 100 % before switching on the material simulation.
--	---

4 Special inputs and outputs

4.1 Function of inputs

Material simulation I12

- ◆ With I12="1" the material simulation is activated.
- P36 material speed in % of the nominal speed.
- P36 = 0: material speed is predefined via the override input.

Manual cut I13

- ◆ With I13="1" an applied synchronization command will be executed immediately.

Enable label reference I14

- ◆ With I14="1" the label reference is switched on. COMPAX analyzes the signal of I14
 - ◆ with the first cut on the fly command and
 - ◆ with the signal I15 (end of synchronous travel)

End of synchronous travel I15



- ◆ With I15="1" the synchronous travel will end, the drive decelerates.
- ◆ I15 will be analyzed only during the synchronous travel.
- ◆ "Quick start" mode is not possible.

Label input I16

- ◆ During enabled label reference, a label is recognized with a positive, edge at I16.
- ◆ Label input I16 will not analyzed in the
 - ◆ synchronous process and
 - ◆ during the acceleration to material speed.

Initiation of the functions

Described are transitions, which initiate the functions. All other transitions and status do not initiate functions.

Function	I12	I13	I14	I15	I16
Material simulation	1	X	X	X	X
Manual cut	X		X	X	X
Enable label reference	X	X	1	X	X
End of synchronous travel	X	X	X	1	X
Label input	X	X	1	X	

4.2 Function of outputs

Synchronous comparator: O14

- ◆ With O14 = "1" the processing of the traveling material is started.
- ◆ O14 = "1" is set if:
 - ◆ the drive is in synchronization with the material and additionally
 - ◆ the drive has passed the travel distance given in P33 (synchronous comparator).
- ◆ O14 is set back by ending the synchronous travel (by a positive edge at I15, after waste length, after chaff length, by error and break).

Chaff length O15

- ◆ With O15="0" this signals, that the drive can not follow the required length or the chaff length and
 - ◆ for P37 > 0 synchronizes to chaff length.
 - ◆ for P37 = 0 executes no synchronous travel.

Waste length O16

Without label reference:

- ◆ With O16="0" this signals, that the drive could not follow the required length and synchronizes to waste length.

With label reference:

- ◆ With O16="0" this signals that the label is missing beyond the label window (waste length - 2 * acceleration travel for synchronization) and will synchronize to waste length.

5 Special status assignment

S41: Material speed in % relative to the nominal speed of the axis.

S42 Moved material length since the last processing. With label reference mode the moved material length after label is indicated.

S45: Acceleration travel for synchronization

Size of the status values: 8 number values before decimal point; 3 number values after decimal point

6 Analogue output

The D/A-Monitor (option D1) offers you the possibility of outputting the length and the material speed as an analogue value.

Selection:

P73/P74	Measuring value	Reference value ¹
20	cut length	32768 units (mm/inch)
21	material speed ²	20000min ⁻¹

Via the amplification factor P71 or P72, you can adjust the scale of output. It is limited to 10V.

$$P71/P72 = \frac{\text{reference value}}{\text{value at 10V}}$$

During the cutting length output, the analogue value gets 0V after

- ◆ BREAK,
 - ◆ STOP (after the end of the synchronization command),
 - ◆ error and
 - ◆ at cut length 0 during label related positioning.
- It will be reactivated during the next synchronization command.



During the system selftest (after system startup of COMPAX), the analogue output is at 10V.



For more details on D/A monitor, see Accessories/options in the COMPAX User Guide.

7 Encoder-interface

The material speed will be recorded via the encoder input (channel 1). The following parameters have to be adjusted:

P143: Encoder pulse per revolution

P98: Travel of the axis per encoder revolution.



The frequency of the encoder signal has to be at least 4kHz

¹ Physical value at 10V and amplification 1.

² The recognition of a label will be signaled by a negative pulse (1ms).

8 Cutting on the fly parameters

No.	Meaning	Unit	Minimum value	Default value	Maximum value	Valid from...
Cutting on the fly parameters						
P30	Minimum travel to label	corresp. P90	0	0	100 000	VP
P31	Position of the label sensor relative to the machine zero	corresp. P90	-10 000	0	100 000	VP
P32	relative target position*	corresp. P90	P11	0	P12	VP
P33	Synchronous comparator	corresp. P90	0	0	100 000	VP
P34	Deceleration travel for synchronization*	corresp. P90	-100000	0	100000	VP
P35	Acceleration travel for synchronization [#]	corresp. P90	0	0	256 motor rotation	VP
P36	Material simulation	%	0	0	100	VP
P37	Waste length	corresp. P90	0	0	100 000	VP
P38	Saw blade correction	corresp. P90	0	0	100 000	VP
P39	Angle of beam [#]	degree	0	0	80	VP
Define Encoder-interface (option)						
P143	Encoder pulse per revolution (channel 1)		120	4096	2 000 000	VC
P98	Travel of axis per encoder revolution	corresp. P90	0	0	4 000 000	VC

* A modification to P32 or P34 is taken into account up until the end of the synchronous travel.

[#] P35 and P39 must not be modified with VP during stage 1-4 (see page 5)!

