

L-force Controls

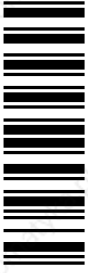

Operating Instructions

Industrial PC

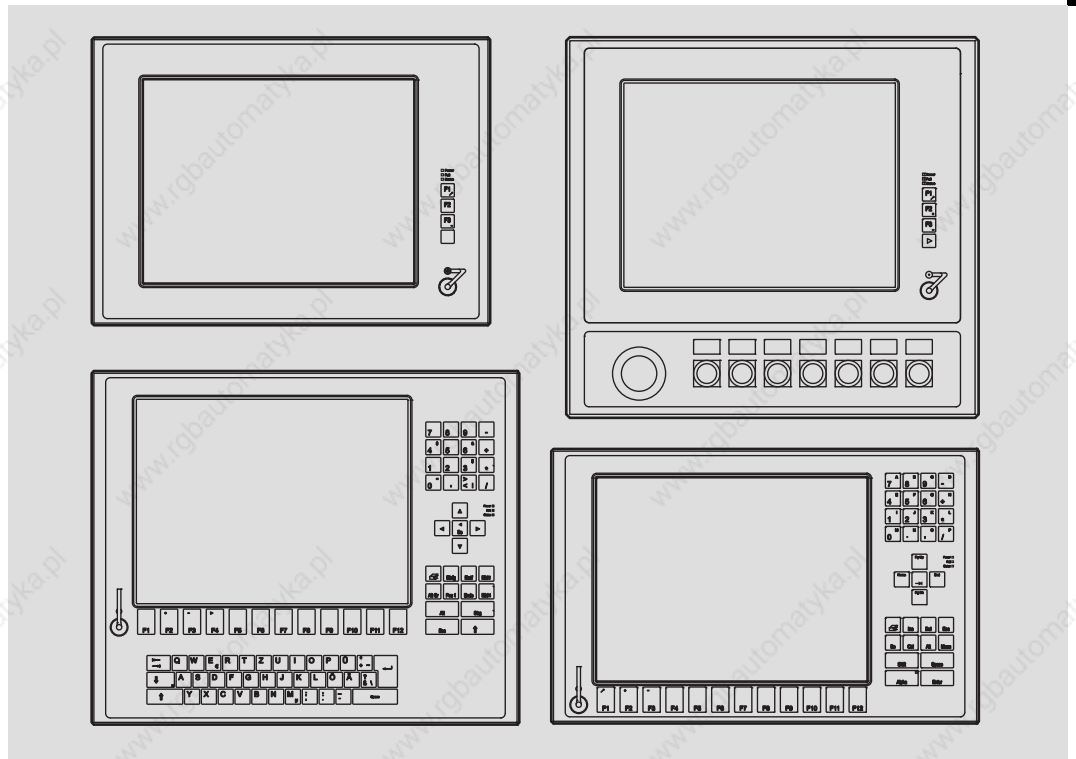

CS 5000 DVI ... CS 9000 DVI

Monitor Panel (Command Station)



Please read these instructions before you start working!
Follow the enclosed safety instructions.

1	About this documentation	5
1.1	Document history	5
1.2	Conventions used	6
1.3	Notes used	7
2	Safety instructions	8
2.1	General safety information	8
2.2	Product-specific safety instructions	10
2.3	Safety instructions for the installation according to UL	11
3	Product description	13
3.1	Scope of supply	13
3.2	Application as directed	14
3.3	Device features	14
3.4	Identification	17
3.5	Controls and displays	18
3.6	Options	19
3.6.1	Add-on components	19
4	Technical data	21
4.1	General data and operating conditions	21
4.2	Electrical data	23
4.3	Mechanical data	24
5	Mechanical installation	26
5.1	Important notes	26
5.2	Mounting steps	27
5.2.1	Removing the mounting frame	27
5.2.2	Fixing the mounting frame to the support arm	28
5.2.3	Fixing the mounting frame to the wall	30
5.3	Changing the labelling of the operator console	32

6	Electrical installation	33
6.1	Important notes	33
6.2	Wiring according to EMC	35
6.3	Connecting the supply and peripheral devices	36
6.3.1	Preliminary works	36
6.3.2	Terminal diagram supply	37
6.3.3	24 V connection	37
6.3.4	DVI interface	38
6.3.5	USB interface	38
6.3.6	USB interface on the front face (option)	38
6.3.7	Mounting frame connecting plate (option)	39
6.4	Assignment of the operator console connector board (only CS 5010 DVI)	40
7	Operation	41
7.1	Important notes	41
7.2	Controls and displays	42
7.2.1	Command Station CS 5000 DVI and CS 9000 DVI	42
7.2.2	Command Station CS 5010 DVI	43
7.2.3	Command Station CS 5050 DVI	44
7.2.4	Command Station CS 5070 DVI	44
8	Maintenance	46
8.1	Regular checks	46
8.2	Cleaning	47
8.3	Repair	48
8.3.1	Removing and mounting the screen	48
8.3.2	Fuse change	50
9	Index	51

1 About this documentation

Contents

This documentation provides you with information about the intended use of the monitor panel.

The present manual is part of the "Controller-based automation" or "PC-based automation" manual collection which you can find on the DVDs of the same name.

Target group

This documentation is directed at qualified skilled personnel according to IEC 60364.

Qualified skilled personnel are persons who have the required qualifications to carry out all activities involved in installing, mounting, commissioning, and operating the product.



Tip!

Information and auxiliary devices related to the Lenze products can be found in the download area at <http://www.Lenze.com>

Validity

These instructions are valid for

- ▶ Command Station CS 5000 DVI
- ▶ Command Station CS 5010 DVI
- ▶ Command Station CS 5050 DVI
- ▶ Command Station CS 5070 DVI
- ▶ Command Station CS 9000 DVI

1.1 Document history







Material number	Version			Description
13458294	4.0	02/2014	TD06	New: <ul style="list-style-type: none"> ● UL notes (French language) ● Notes RJ45 cable laying
13433083	3.0	03/2013	TD29	General Revision
13392305	2.0	11/2011	TD29	Supplement of the note concerning the protection against direct solar radiation, as well as chapter "Repair"
13385510	1.0	07/2011	TD29	First edition

1 About this documentation

Conventions used

1.2 Conventions used

This documentation uses the following conventions to distinguish between different types of information:

Type of information	Identification	Examples/notes
Spelling of numbers		
Decimal separator	Point	In general, the decimal point is used. For instance: 1234.56
Warnings		
UL warnings		Given in English and French
UR warnings		
Text		
Program name	» «	PC software For example: »Engineer«, »Global Drive Control« (GDC)
Icons		
Page reference		Reference to another page with additional information For instance:  16 = see page 16
Documentation reference		Reference to another documentation with additional information For example:  EDKxxx = see documentation EDKxxx

1.3

Notes used

The following pictographs and signal words are used in this documentation to indicate dangers and important information:

Safety instructions

Structure of safety instructions:

**Danger!**

(characterises the type and severity of danger)

Note

(describes the danger and gives information about how to prevent dangerous situations)

Pictograph and signal word	Meaning
Danger!	Danger of personal injury through dangerous electrical voltage. Reference to an imminent danger that may result in death or serious personal injury if the corresponding measures are not taken.
Danger!	Danger of personal injury through a general source of danger. Reference to an imminent danger that may result in death or serious personal injury if the corresponding measures are not taken.
Stop!	Danger of property damage. Reference to a possible danger that may result in property damage if the corresponding measures are not taken.

Application notes

Pictograph and signal word	Meaning
Note!	Important note to ensure troublefree operation
Tip!	Useful tip for simple handling
Reference!	Reference to another documentation

Special safety instructions and application notes

Pictograph and signal word	Meaning
Warnings!	Safety note or application note for the operation according to UL or CSA requirements.
Warnings!	The measures are required to meet the requirements according to UL or CSA.

Scope

The following general safety instructions apply to all Lenze drive and automation components.

The product-specific safety and application notes given in this documentation must be observed!

For your own safety**Danger!**

Disregarding the following basic safety measures may lead to severe personal injury and damage to material assets!

- ▶ Lenze drive and automation components ...
 - ... must only be used for the intended purpose.
 - ... must never be operated if damaged.
 - ... must never be subjected to technical modifications.
 - ... must never be operated unless completely assembled.
 - ... must never be operated without the covers/guards.
 - ... can - depending on their degree of protection - have live, movable or rotating parts during or after operation. Surfaces can be hot.
- ▶ For Lenze drive and automation components ...
 - ... only use approved accessories.
 - ... only use original manufacturer spare parts.
- ▶ All specifications of the corresponding enclosed documentation must be observed. This is vital for a safe and trouble-free operation and for achieving the specified product features.

The procedural notes and circuit details provided in this document are proposals which the user must check for suitability for his application. The manufacturer does not accept any liability for the suitability of the specified procedures and circuit proposals.
- ▶ Only qualified skilled personnel are permitted to work with or on Lenze drive and automation components.

According to IEC 60364 or CENELEC HD 384, these are persons ...

 - ... who are familiar with the installation, assembly, commissioning and operation of the product,
 - ... possess the appropriate qualifications for their work,
 - ... and are acquainted with and can apply all the accident prevent regulations, directives and laws applicable at the place of use.

Transport, storage

- ▶ Transport and storage in a dry, low-vibration environment without aggressive atmosphere; preferably in the packaging provided by the manufacturer.
 - Protect against dust and shocks.
 - Comply with climatic conditions according to the technical data.

Mechanical installation

- ▶ Install the product according to the regulations of the corresponding documentation. In particular observe the section "Operating conditions" in the chapter "Technical data".
- ▶ Provide for a careful handling and avoid mechanical overload. During handling neither bend components, nor change the insulation distances.
- ▶ The product contains electrostatic sensitive devices which can easily be damaged by short circuit or static discharge (ESD). Thus, electronic components and contacts must not be touched unless ESD measures are taken beforehand.

Electrical installation

- ▶ Carry out the electrical installation according to the relevant regulations (e. g. cable cross-sections, fusing, connection to the PE conductor). Additional notes are included in the documentation.
- ▶ When working on live products, observe the applicable national regulations for the prevention of accidents (e.g. BGV 3).
- ▶ The documentation contains notes for the EMC-compliant installation (shielding, earthing, arrangement of filters and installation of the cables). The manufacturer of the system or machine is responsible for the compliance with the limit values required in connection with EMC legislation.
- ▶ For compliance with the limit values for radio interference emission at the site of installation, the components - if specified in the technical data - have to be mounted in housings (e. g. control cabinets). The housings have to enable an EMC-compliant installation. In particular observe that for example control cabinet doors preferably have a circumferential metallic connection to the housing. Reduce openings or cutouts through the housing to a minimum.
- ▶ Only plug in or remove pluggable terminals in the deenergised state!

Commissioning

- ▶ If required, you have to equip the system with additional monitoring and protective devices in accordance with the respective valid safety regulations (e. g. law on technical equipment, regulations for the prevention of accidents).

Maintenance and servicing

- ▶ The components are maintenance-free if the required operating conditions are observed.
- ▶ If the cooling air is polluted, the cooling surfaces may be contaminated or the air vents may be blocked. Under these operating conditions, the cooling surfaces and air vents must be cleaned at regular intervals. Never use sharp objects for this purpose!
- ▶ After the system has been disconnected from the supply voltage, live components and power connections must not be touched immediately because capacitors may be charged. Please observe the corresponding notes on the device.

Disposal

- ▶ Recycle or dispose of the product according to the applicable regulations.

2.2**Product-specific safety instructions**

- ▶ Protect the device against direct solar radiation, since the housing may heat up strongly.
- ▶ The device is classified as a class A device and can cause radio interference in residential areas. In this case, the operator may have to take special measures. Any costs arising from these measures have to be paid by the operator.
- ▶ A touchscreen does not comply with the Ergonomics Directive ZH 1/618. This is why it is only designed for short-time inputs and monitoring functions. For longer inputs, connect an external keyboard.
- ▶ In the event of a fault, unplug the power connector immediately and send back the device to the manufacturer. The address can be found on the self-addressed envelope included in this documentation. Please use the original packaging to return the device!
- ▶ Printed circuit boards which might be damaged by short circuit or electrostatic discharge (ESD) must be handled appropriately.

2.3 Safety instructions for the installation according to UL

Original - English

Approval

Underwriter Laboratories (UL), UL508 and CSA C22.2 No. 142-M1987, (UL File Number E236341)

Ratings

- ▶ Input 24 V DC, max. 65 W (65 VA)
- ▶ Max. ambient temperature 40 °C
- ▶ Environmental ratings: Type 1 Enclosure
- ▶ Optional communication ratings:
 - RS232-Connection: max. 3 A
 - USB-Connection, PS/2-Connection: max. 1 A
 - LAN-Connection: Standard ISDN or RJ45
 - VGA-Connection, FBAS-Connection, DVI-Connector, DPL-Connection: max. 4 A
 - External Power Supply for DVI/USB Extender: max. 4 A
 - Video-DSUB Connection for DVI/USB Extender: max. 4 A
 - Data-DSUB Connection for DVI/USB Extender : max. 4 A



Warnings!

Conditions of acceptability

- ▶ These devices are evaluated to meet environmental UL Type 1 Enclosure requirements, when all openings in the enclosure back are closed (filled) by devices with suitable environmental type ratings. This may be achieved by use of appropriate supporting beam (support arm system), with suitable environmental ratings or equivalent means.
- ▶ Models CS5710 IPC and CS5710 DVI are rated for environmental UL Type 1 Enclosure, when openings in the front are closed with suitable devices (e.g. buttons, emergency off button, etc.).
- ▶ The effects of condensation or high humidity shall be reduced by the application of heat through continuous energization of the equipment, with interruptions such that cooling to the point of condensation does not occur.
- ▶ The devices are intended for the use in a pollution degree 2 or controlled environment only.

Field Wiring Markings

Wiring Terminal MSTB 2,5/3-STF-5,08:

- ▶ Use Copper Wire only.
- ▶ AWG 18 ... AWG 12 (0.82 mm²... 3.3 mm²)
- ▶ Torque 5...7 lb-in (0.5 ... 0.6 Nm)

Safety instructions

Safety instructions for the installation according to UL

Original - French

Homologation

Underwriter Laboratories (UL), UL508 et CSA C22.2 n° 142-M1987, (n° de dossier UL E236341)

Caractéristiques assignées

- ▶ Entrée 24 V CC, maximum 65 W (65 VA)
- ▶ Température ambiante maximale : 40 °C
- ▶ Evaluation environnementale : coffret de type 1
- ▶ Caractéristiques de communication assignées (option) :
 - Port RS232 : maximum 3 A
 - Port USB, port PS/2 : maximum 1 A
 - Port LAN : RNIS standard ou RJ45
 - Port VGA, port FBAS, connecteur DVI, port DPL : maximum 4 A
 - Alimentation externe pour carte d'extension DVI/USB : maximum 4 A
 - Port vidéo DSUB pour carte d'extension DVI/USB : maximum 4 A
 - Port de données DSUB pour carte d'extension DVI/USB : maximum 4 A



Warnings!

Conditions d'acceptabilité

- ▶ Ces équipements sont évalués en vue de déterminer la conformité aux exigences environnementales UL pour un coffret de type 1, toutes les ouvertures à l'arrière du coffret étant fermées (obturées) par des dispositifs appropriés. Pour cela, il convient d'utiliser une traverse de support (système à bras porteur) appropriée ou un système équivalent.
- ▶ Les modèles CS5710 IPC et CS5710 DVI sont conçus pour un coffret de type 1 (classification environnementale UL), toutes les ouvertures à l'avant du coffret étant fermées par les dispositifs adaptés (touches de commande, bouton d'arrêt d'urgence, etc.).
- ▶ Les effets de la condensation ou d'une humidité importante peuvent être compensés par la chaleur générée par une mise sous tension continue de l'équipement. Les interruptions doivent être contrôlées de façon à ce que le point de condensation ne soit pas atteint durant les phases de refroidissement.
- ▶ Les équipements sont destinés exclusivement à être utilisés dans un environnement contrôlé, caractérisé par le degré de pollution 2.

Marquage du câblage à pied d'oeuvre

Bornier de câblage MSTB 2,5/3-STF-5,08 :

- ▶ Utiliser exclusivement des conducteurs en cuivre.
- ▶ AWG 18 ... AWG 12 (0,82 mm²... 3,3 mm²)
- ▶ Couple de 5 à 7 lb-in (0,5 ... 0,6 Nm)

3 Product description

3.1 Scope of supply

Quantity	Name
1	Monitor panel
1	Connection plug for voltage supply
1	DVI-D cable (length 2 m)
1	USB cable (length 2 m)
1	Fixing adapter (option)
1	DVD "PC based Automation"
1	Test report
1	Device pass card



Note!

After receipt of the delivery, check immediately whether the items match the accompanying papers. We do not accept any liability for deficiencies claimed subsequently.

Claim

- ▶ visible transport damage immediately to the forwarder
- ▶ visible deficiencies/incompleteness immediately to your Lenze representative.

3 Product description

Application as directed

3.2 Application as directed

The monitor panel is used as intended if it is used solely for providing information in common industrial and commercial areas. Another use or any further use is not permissible.

A **use that is not intended** also includes a use harbouring fatal risks or dangers which, without the provision of exceptionally high safety measures, may result in death, injury or damage to material assets.

The monitor panel must in particular **not** be used ...

- ▶ in private areas.
- ▶ in potentially explosive atmospheres.
- ▶ in areas with harmful gases, oils, acids, radiation, etc.
- ▶ in applications where vibration and impact loads occur, exceeding the requirements of EN 50178.
- ▶ for performing safety functions, for instance
 - in air traffic control / in flight-control systems
 - for the monitoring/control of nuclear reactions
 - for the monitoring/control of means of mass transport
 - for the monitoring/control of medical systems
 - for the monitoring/control of weapon systems

Higher-level safety systems must be used to guarantee the protection of persons and material assets!

3.3 Device features

	CS x0xx DVI
Design	<ul style="list-style-type: none">● Front frame of anodised and etched aluminium● Mounting frame made of stainless steel● Front made of polyester foil● Control elements can be expanded by add-on components
Mounting	<ul style="list-style-type: none">● Mounting frame with VESA-100 adapter surface● For wall or support arm mounting● Adaptable to various support arm systems via adapter plate
Electrical supply	<ul style="list-style-type: none">● 24 V DC voltage supply
Interfaces	<ul style="list-style-type: none">● 1 x DVI● 2 x USB type A (V 2.0)● 1 x USB type B (V 2.0)

Accessories

- ▶ Add-on component
 - With control desk for 7 or 14 switching elements and emergency-off switch
 - With MF2 keyboard in stainless steel finish
- ▶ DVI/USB extender

Overview

Command Station CS 5000 DVI / CS 9000 DVI

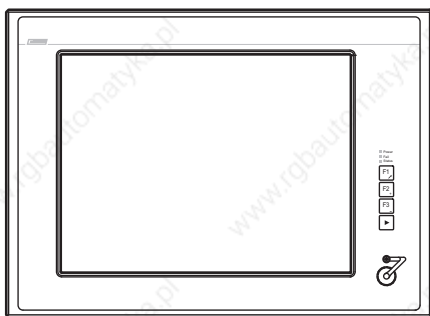

CS57x0-026

- CS 5000 DVI: XGA touchscreen 38.1 cm (15")
CS 9000 DVI: SXGA touchscreen 48.3 cm (19")
- 3 freely assignable function keys

Command Station CS 5010 DVI

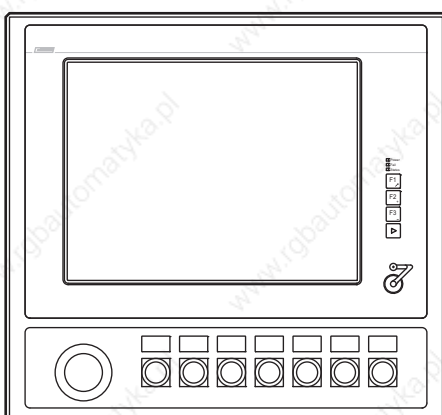

CS57x0-027

- XGA touchscreen 38.1 cm (15")
- 3 freely assignable function keys
- Up to 7 freely assignable switching elements
- Emergency-off switch

Command Station CS 5050 DVI

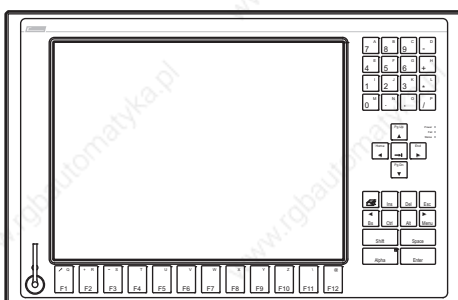

CS57x0-028

- XGA touchscreen 38.1 cm (15")
- 12 freely assignable function keys
- Numeric keypad, control keys, level switch-over Alpha

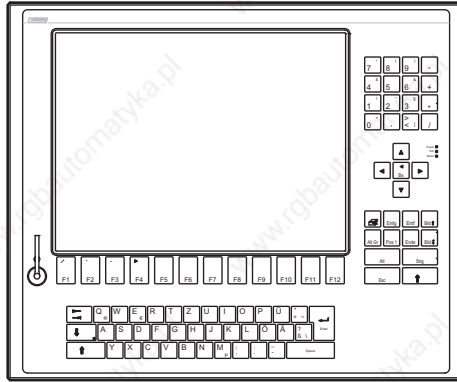
Command Station CS 5070 DVI

CS57x0-029

- XGA touchscreen 38.1 cm (15")
- 12 freely assignable function keys
- MF2 keyboard

3.4

Identification



DVIUSB-012

- ① Type designation
- ② Type code (catalogue/order no.)
- ③ Technical data
- ④ Customised material number
- ⑤ Bar code with serial number
- ⑥ Manufacturer address
- ⑦ Certification
- ⑧ CE mark

Type code

②				
xxxx	2	x	x	x

- 6300 = CS 5000 DVI
- 6301 = CS 9000 DVI
- 6302 = CS 5010 DVI
- 6303 = CS 5050 DVI
- 6304 = CS 5070 DVI, keyboard layout German
- 6305 = CS 5000 DVI, keyboard layout English

- Front face USB socket
- 0 = without
 - 1 = with (IP65)

- Mounting frame (at the bottom)
- 0 = without cable gland
 - 1 = with universal double cable gland (KDL-2, no UL!)
 - 3 = with 1 x USB socket in mounting frame (IP65)
 - 4 = with 2 x USB socket in mounting frame (IP65)

- Fixing adapter
- 0 = VESA 100
 - 1 = VESA, closed
 - 2 = Rittal CP-L
 - 3 = Rittal CP-S V2A
 - X = customised version

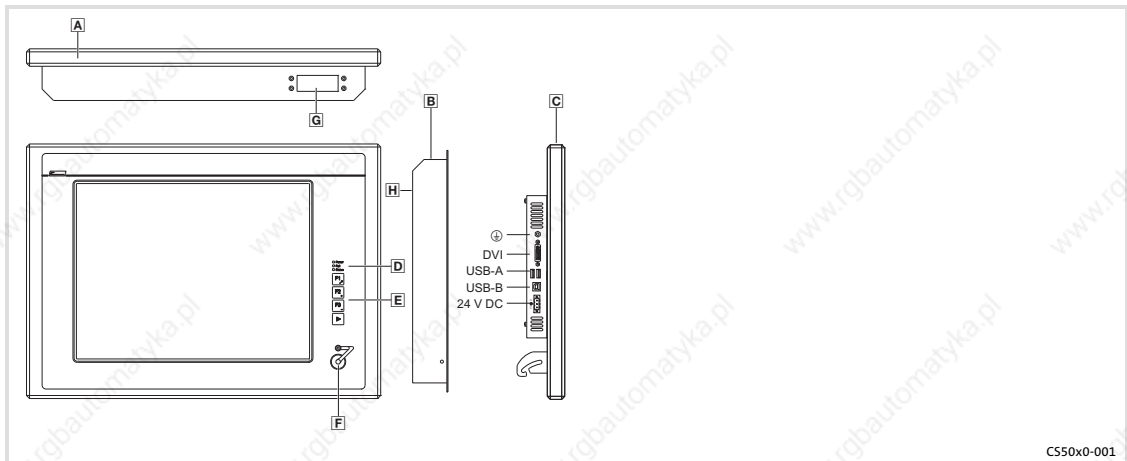

Pos.	Description
A	Command Station (here CS 5000 DVI)
B	Mounting frame
C	Screen
D	Status LEDs (Power, Fail, Status)
E	Front face control elements
F	Front face USB port (option)
G	Mounting frame connecting plate (option)
H	Nameplate



Note!

Further information on the control and display elements can be gathered from the chapter "Operation" (41).

3.6 Options

3.6.1 Add-on components

Operator console CSB 7

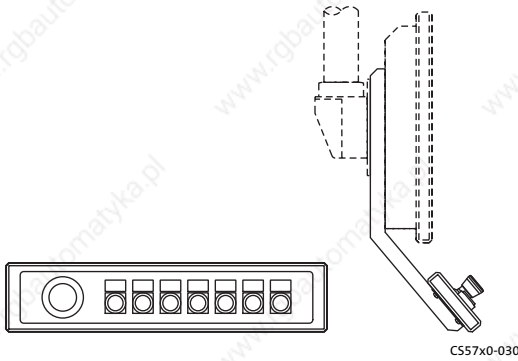

- Up to 7 freely assignable switching elements that can be used in any combination
- Emergency-off switch
- Internal cabling for Command Station with Combicon plug

Operator console CSB 14

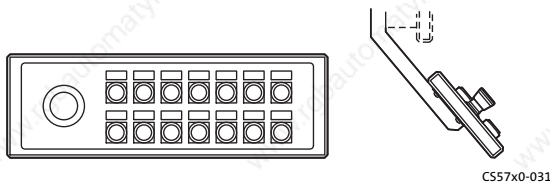

- Up to 14 freely assignable switching elements that can be used in any combination
- Emergency-off switch
- Internal cabling for Command Station with Combicon plug



Note!

Corresponding to their order specifications, the operator consoles can be assembled, wired, and labelled with control and display elements by the factory.

The operator consoles can be assembled with RAFI control/display elements of the RAFIX 22 FS type (printed circuit board mounting). The design is adapted to the visual appearance of the Command Station.



Control/Display elements of type RAFIX 22 FS

- Square-law flange, dark grey
- Flat front ring, silver metallic
- Lighting by very bright LED
- Colour of fascia panel white, yellow, green, red, or blue
- Key-operated switch with two keys; different versions available
- Emergency stop pushbutton
 - With potential-free contacts
 - With unlabelled yellow sticker (Ø60 mm, in accordance with DIN EN ISO 13850)

Product description

Options

Add-on components

Keyboard CSB MF2 E

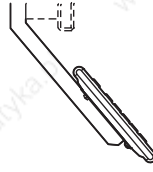
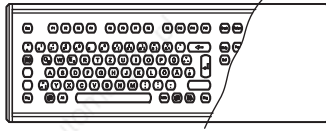

CS57x0-033

- MF2 keyboard with long-throw keys in stainless steel finish
- Internal cabling for Command Station with USB plug
- Design types:
 - with NUM block
 - with touch pad
- Available languages:
 - German, English, French
 - Others on request

Add-on components with combinations of operator console and keyboard are available.

4 Technical data

4.1 General data and operating conditions

General data

Conformity and approval		
Conformity		
CE	EN 61000-6-4 EN 61000-6-2	EMC Directive Class A, industrial premises
Approbation		
UR	UL 508 CSA C22.2	Programmable Controllers (File-No. E236341)
Other		
RoHS	-	Products lead-free in accordance with CE Directive 2011/65/EU

Protection of persons and equipment		
Safety	VDE0805 (EN60950), VDE0870, UL	
Enclosure		
Standard device	EN 60529	IP65
	UL 508 (NEMA 250)	Type 1 enclosure pollution degree 2
Add-on components	EN 60529	IP65
Class of protection		3

EMC		
Noise emission	EN 61000-6-4	Class A (industrial premises)
Noise immunity zone B	EN 61000-6-2	Industrial premises
	EN 61000-4-2	ESD; severity level 3, i. e. 8 kV for air discharge, 4 kV for contact discharge
	EN 61000-4-3	RF interference (housing) 80 MHz ... 1000 MHz, 10 V/m 80 % AM (1 kHz)
	EN 61000-4-4	Burst, severity level 3
	EN 61000-4-5	Surge, severity level 1 *
	EN 61000-4-6	RF cable-guided 150 kHz ... 80 MHz, 10 V/m 80 % AM (1 kHz)

* Due to the high-energy single current pulses, surges require suitable external wiring with lightning protection elements like for example lightning conductors and overvoltage arresters.

Operating conditions

Mounting conditions		
Mounting place		Stand-alone operator console for support arm mounting or direct fixing to a wall, protected against direct solar radiation
Ambient conditions		
Climatic		
Storage		-10 ... +60 °C
Transport		-10 ... +60 °C
Operation		+5 ... +45 °C
Relative humidity		10 ... 90 %, non-condensing
Site altitude		
Storage/Transport		< 12000 m amsl
Operation		< 3000 m amsl
Chemical resistance		
Decor film	DIN 42115	
Touch/display		
Mechanical load capacity		
Decor film	DIN 42115	max. 100 N
Touch/display		
Switching element		

4.2

Electrical data

Standard device

Type	Supply		Screen					
	Voltage [V DC]	Current at 24 V [A]	Visible size [cm]	Aspect ratio	Resolution [pixels]	Brightness [cd/m ²]	Contrast	MTFB [h]
CS 5000 DVI	24 (+18 ... 30)	0.9	38.1 (15")	4 : 3	1024 x 768	250	1 : 550	40,000
CS 5010 DVI								
CS 5050 DVI								
CS 5070 DVI								
CS 9000 DVI		1.4	48.3 (19")	5 : 4	1280 x 1024	300	1 : 2000	50,000

Operator console

Control desk switching elements

Type	Max. switching voltage [V AC/DC]	Max. switching current [mA]	Max. switching capacity [mW]
RAFIX 22 FS	42	100	250

Control desk LED

Type	Forward voltage, typ. U_F at I_F [V]	Max. current I_F [mA]
RAFIX 22 FS, 3 mm		
White	3.6 V/20 mA V	30
Yellow	1.9 V/20 mA V	50
Red	1.9 V/20 mA V	50
Blue	3.6 V/20 mA V	30
Green	3.5 V/20 mA V	30

4.3

Mechanical data

Standard device

Versions and weights				
	Front frame	Mounting frame	Touchscreen	Mass *) [kg]
CS 5000 DVI	Aluminium	Stainless steel	Polyester foil	10.0
CS 5010 DVI				
CS 5050 DVI				
CS 5070 DVI				
CS 9000 DVI				12.0

*) Without adapter plate and add-on component

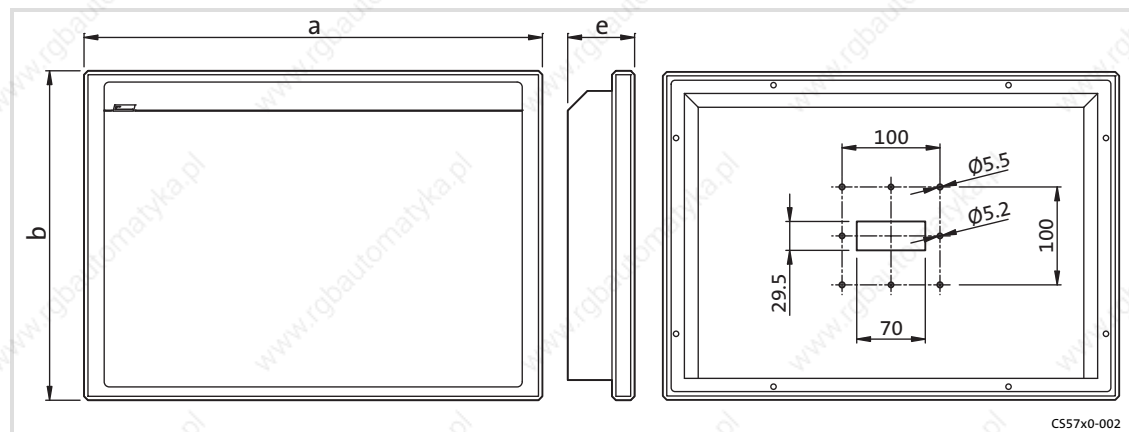

All dimensions in millimetres.

Dimensions			
	a	b [mm]	e
CS 5000 DVI	466	355	68
CS 5010 DVI	466	430	78
CS 5050 DVI	500	330	68
CS 5070 DVI	499	410	78
CS 9000 DVI	506	410	78

Add-on components

Versions and weights			
	Operator console / keyboard	Add-on component support arm	Mass * [kg]
CSB 7	Aluminium, anodised and etched	Stainless steel	4.0
CSB 14			5.0
CSB MF2E	Stainless steel	Stainless steel	5.0
CSB 7 with CSB MF2E	Aluminium, anodised and etched, keyboard stainless steel	Stainless steel	6.7

* Without display and control elements

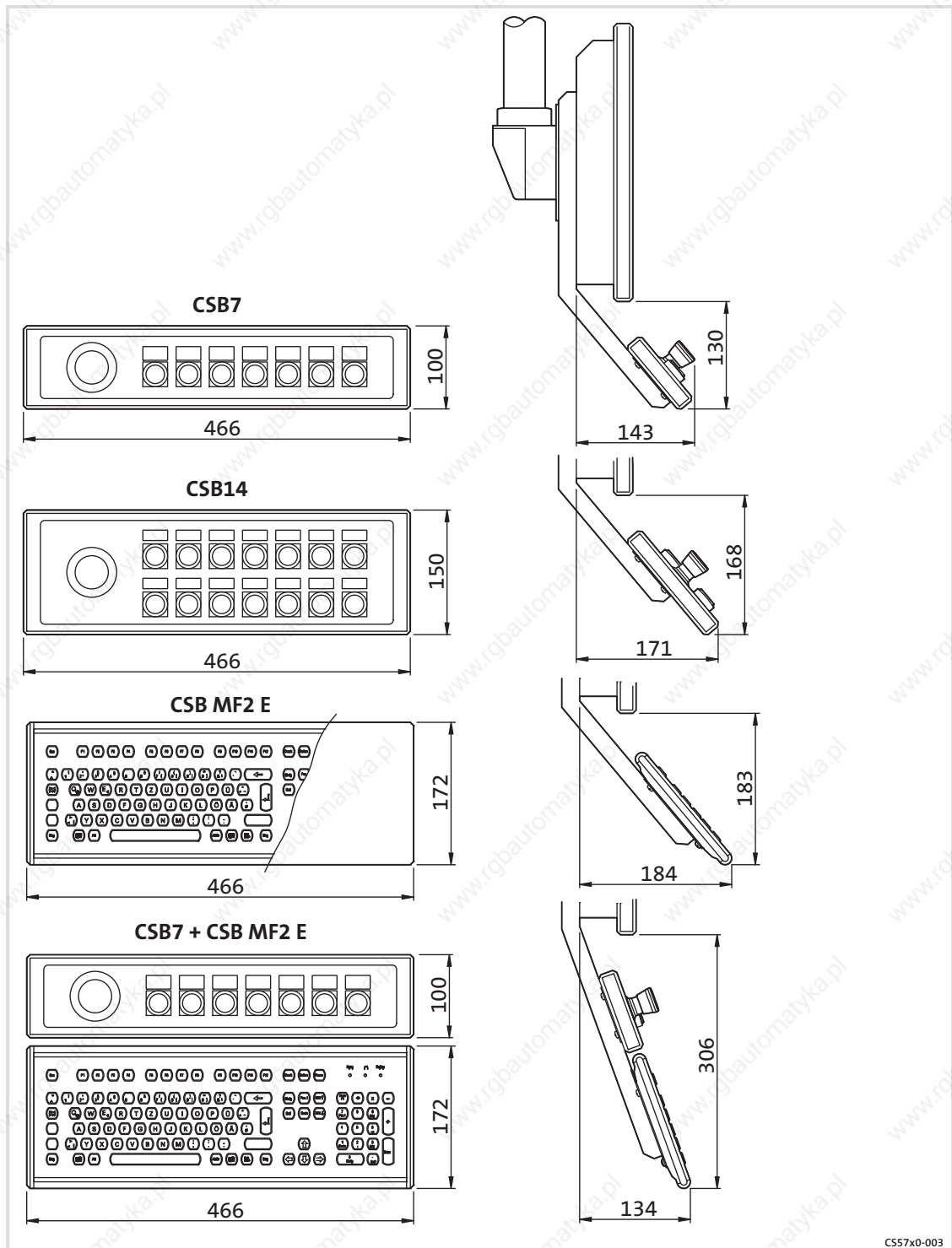

5 Mechanical installation

Important notes

5 Mechanical installation

5.1 Important notes

The installation must be carried out by qualified, skilled personnel familiar with the applicable national standards.



Stop!

Sensitive front frame gasket

During mounting, the gasket of the front frame is exposed and can be damaged.

Possible consequences:

- ▶ The degree of protection provided by the enclosure mentioned in the technical data is not attained.

Protective measures:

- ▶ Handle the gasket with care during mounting.
- ▶ Protect the gasket against ultraviolet rays.
- ▶ Each time before you mount the device, check whether the gasket is intact.



Stop!

Sensitive touchscreen surface

The touchscreen foil is very sensitive to external forces and can be damaged by improper handling.

Possible consequences:

- ▶ The touchscreen foil becomes damaged, scratched or dull.

Protective measures:

- ▶ Avoid contact of the touchscreen foil with pointed or hard objects.
- ▶ Always use a touch pen or your fingers to operate the touchscreen. Never use objects such as ballpoint pens, pencils, etc.
- ▶ When removing dirt and fingerprints, observe the notes given in the chapter "Cleaning" (47).



Note!

When selecting the place where the PC is to be installed, pay attention to an ergonomic positioning of the screen and to the incidence of light which might cause reflections on the screen.

5.2 Mounting steps

5.2.1 Removing the mounting frame

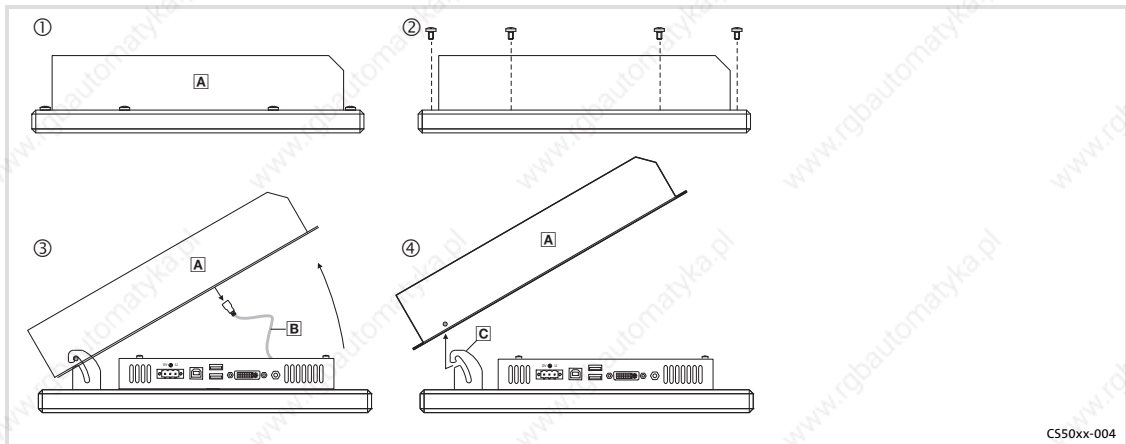

How to proceed:

1. Lay the device flat, with the mounting frame **A** upwards, on a work surface cushioned with a blanket.
 - The work surface must be stable, sufficiently large, and free of any objects. The touchscreen will be damaged when being laid on objects as for instance screws.
2. Remove screws from the mounting frame.
3. Open the mounting frame **A** at the top carefully until it locks and pull the earthing cable **B**.
4. Unlatch the mounting frame **A** from the attachment **C** and remove it.

Now you can mount the mounting frame to a support arm (📖 28) or to a wall. (📖 30)

5.2.2

Fixing the mounting frame to the support arm**Note!**

Before mounting:

- ▶ Remove mounting frame (📖 27).
- ▶ Read documentation of the accessories.
- ▶ Check whether the mounting location corresponds to the operating conditions described in the "Technical data"; if required, take additional measures.

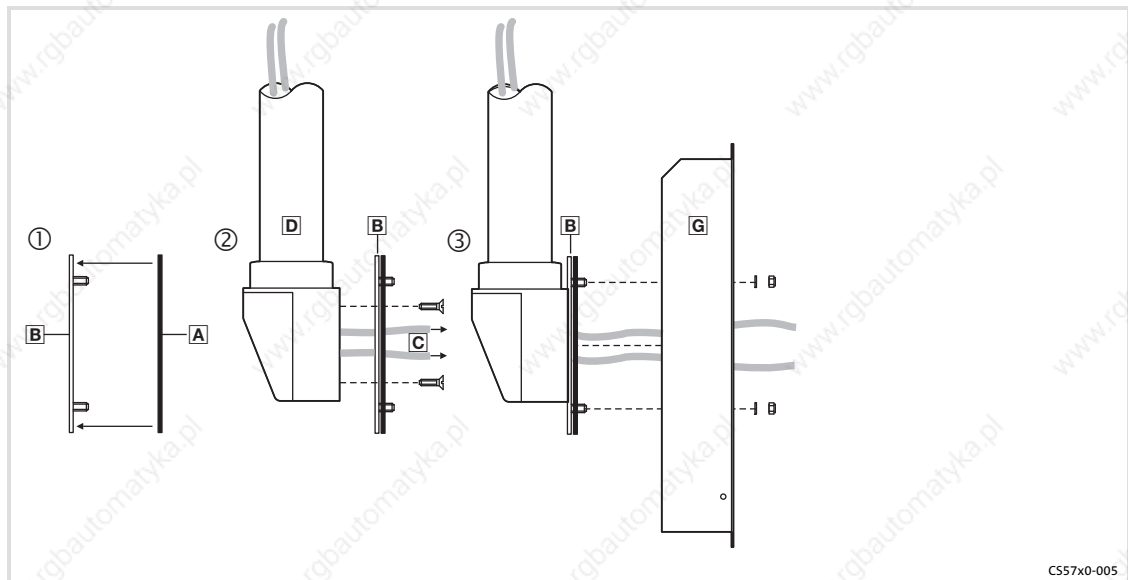
Without add-on component

CS57x0-005

How to proceed:

1. Check support arm system for professional mounting and sufficient carrying capacity.
 - See support arm documentation.
2. Stick the self-adhesive seal **A** on the adapter plate **B** on the side with the threaded bolts.
3. Pull the connecting cables **C** out of the support arm **D** and screw the adapter plate **B** to the support arm **D**.
 - For screws see support arm documentation.
4. Screw the mounting frame **G** to the adapter plate **B**.
 - 4 nuts M5 with washers Ø 5.3 mm

Now you can connect the Command Station (📖 33).

With add-on component

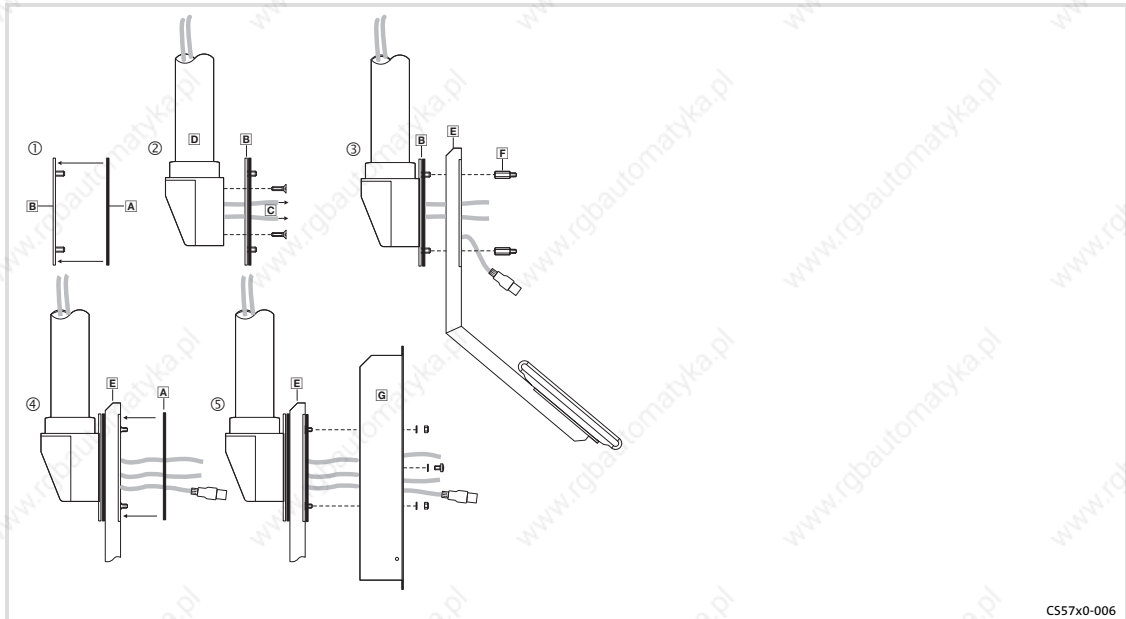

CS57x0-006

How to proceed:

1. Check support arm system for professional mounting and sufficient carrying capacity.
 - See support arm documentation.
2. Stick the self-adhesive seal **A** on the adapter plate **B** on the side with the threaded bolts.
3. Pull the connecting cables **C** out of the support arm **D** and screw the adapter plate **B** to the support arm **D**.
 - For screws see support arm documentation.
4. Screw the add-on component **E** to the threaded bolts of the adapter plate **B**.
 - 4 spacer bolts **F** on the inside/outside M5 x 20 mm
5. Stick the second self-adhesive seal **A** on the add-on component **E**.
6. Screw the mounting frame **G** to the add-on component **E**.
 - 4 nuts M5 with washers \varnothing 5.3 mm
 - 4 screws M5 x 8 mm with washers \varnothing 5.3 mm

Now you can connect the Command Station (33).

5.2.3

Fixing the mounting frame to the wall

**Note!**

Before mounting:

- ▶ Remove mounting frame (📖 27).
- ▶ Read documentation of the accessories.
- ▶ Check whether the mounting location corresponds to the operating conditions described in the "Technical data"; if required, take additional measures.

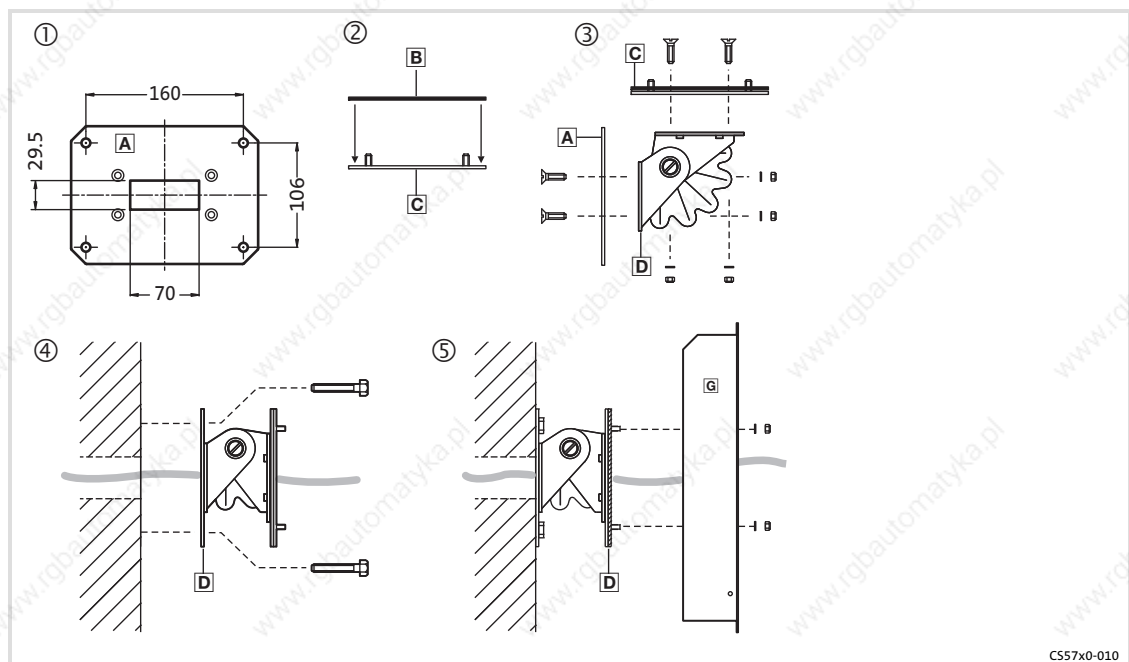
Without add-on component

CS57x0-010

How to proceed:

1. Prepare the wall for mounting the wall bracket **A**.
 - The mounting location and the installation material must provide for a permanent mechanical connection.
2. Stick the self-adhesive seal **B** on the adapter plate **C** on the side with the threaded bolts.
3. Screw the wall bracket **A** and the adapter plate **C** to the swivel adapter **D**.
 - 2 x 4 countersunk head screws M5 x 16 mm with washers \varnothing 5.3 mm and nuts M5
4. Pull the connecting cable through the swivel adapter **D** and screw the swivel adapter to the wall.
5. Screw the mounting frame **G** to the swivel adapter **D**.
 - 4 nuts M5 with washers \varnothing 5.3 mm

Now you can connect the Command Station (📖 33).

With add-on component

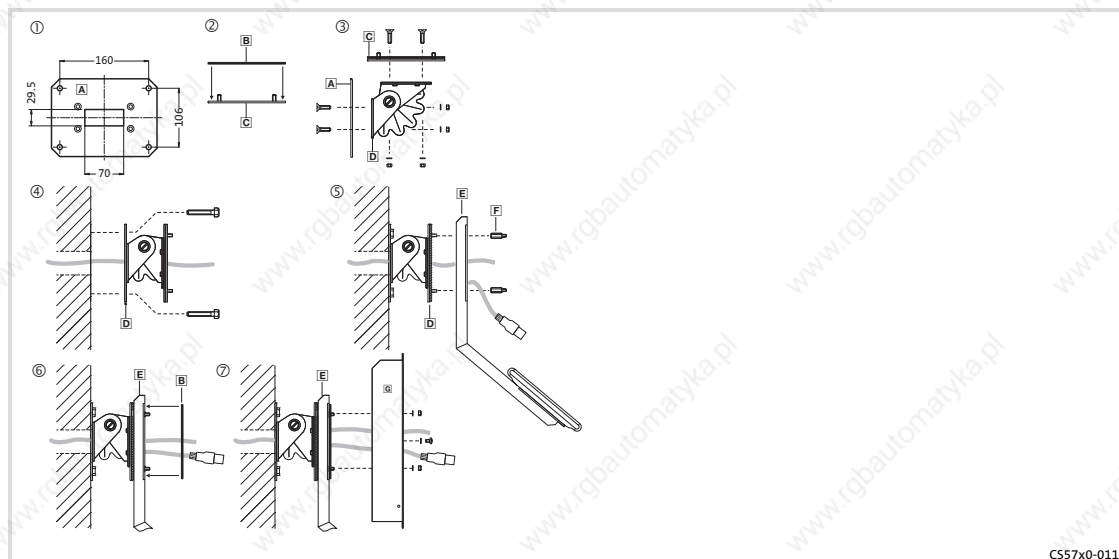

How to proceed:

1. Prepare the wall for mounting the wall bracket **A**.
 - The mounting location and the installation material must provide for a permanent mechanical connection.
2. Stick the self-adhesive seal **B** on the adapter plate **C** on the side with the threaded bolts.
3. Screw the wall bracket **A** and the adapter plate **C** to the swivel adapter **D**.
 - 2 x 4 countersunk head screws M5 x 16 mm with washers \varnothing 5.3 mm and nuts M5
4. Pull the connecting cable through the swivel adapter **D** and screw the swivel adapter to the wall.
5. Screw the add-on component **E** to the threaded bolts of the swivel adapter **D**.
 - 4 spacer bolts **F** on the inside/outside M5 x 20 mm
6. Stick the second self-adhesive seal **B** on the add-on component **E**.
7. Screw the mounting frame **G** to the add-on component **E**.
 - 4 nuts M5 with washers \varnothing 5.3 mm
 - 4 screws M5 x 8 mm with washers \varnothing 5.3 mm

Now you can connect the Command Station ( 33).

5.3

Changing the labelling of the operator console

The control/display elements on the control desk are factory-labelled according to your specifications. If you require a different labelling, create a new labelling strip according to the following outline.

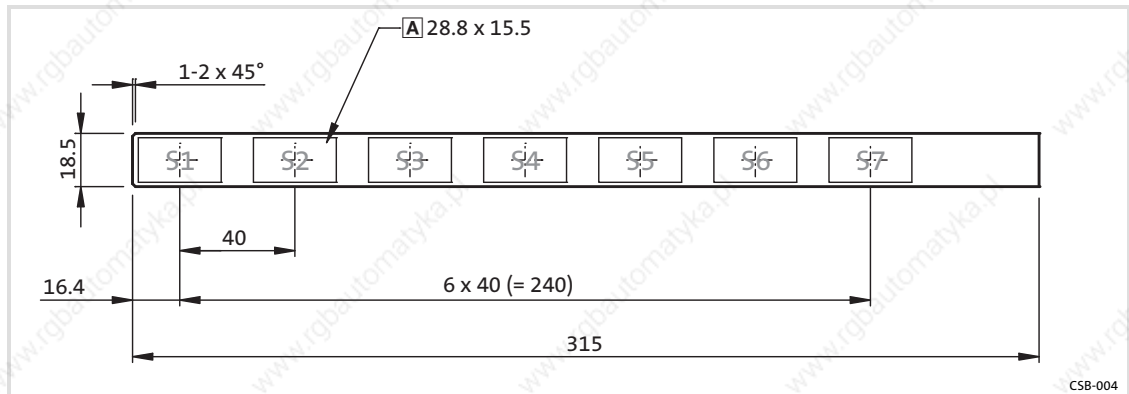

Fig. 5-1 Labelling strip sizes

A Maximum labelling field sizes

All dimensions in millimetres.



Tip!

We recommend glossy paper of 135g/m².

The insertion of the strip can be simplified if the insertion-side corners are provided with a chamfer (see illustration).

The labelling strip can be accessed from the back of the operator panel (inside) when the housing is open.

6 Electrical installation

6.1 Important notes

The installation must be carried out by qualified, skilled personnel familiar with the applicable national standards.



Stop!

Sensitive front frame gasket

During mounting, the gasket of the front frame is exposed and can be damaged.

Possible consequences:

- ▶ The degree of protection provided by the enclosure mentioned in the technical data is not attained.

Protective measures:

- ▶ Handle the gasket with care during mounting.
- ▶ Protect the gasket against ultraviolet rays.
- ▶ Each time before you mount the device, check whether the gasket is intact.



Stop!

Sensitive touchscreen surface

The touchscreen foil is very sensitive to external forces and can be damaged by improper handling.

Possible consequences:

- ▶ The touchscreen foil becomes damaged, scratched or dull.

Protective measures:

- ▶ Avoid contact of the touchscreen foil with pointed or hard objects.
- ▶ Always use a touch pen or your fingers to operate the touchscreen. Never use objects such as ballpoint pens, pencils, etc.
- ▶ When removing dirt and fingerprints, observe the notes given in the chapter "Cleaning" (▣ 47).

**Stop!****Short circuit and static discharge**

The device contains components which are endangered in the case of short circuit or static discharge.

Possible consequences:

- ▶ The device or parts of it will be destroyed.

Protective measures:

- ▶ Always switch off the voltage supply when working on the device. This particularly applies:
 - Before connecting / disconnecting connectors.
 - Before plugging in / plugging out modules.
- ▶ All persons handling printed circuit boards have to take account of ESD measures.
- ▶ Contacts of plug connectors must not be touched.
- ▶ Printed circuit boards may be touched only at places free from electrical contacts and may be placed only on appropriate materials (e.g. on ESD packaging or conductive foam material).
- ▶ Printed circuit boards may only be transported and stored in ESD packaging.

6.2

Wiring according to EMC

General notes	<ul style="list-style-type: none"> ● The electromagnetic compatibility of the system depends on the type and accuracy of the installation. Please especially note the following: <ul style="list-style-type: none"> – Structure – Shielding – Earthing ● In the case of a differing installation it is required for evaluating the conformity to the EMC Directive to check the system with regard to compliance with the EMC limit values. This for instance applies to: <ul style="list-style-type: none"> – The use of unshielded cables ● The end user is responsible for compliance with the EMC Directive. <ul style="list-style-type: none"> – If you observe the following measures, you can be sure that no EMC problems will occur during operation and that the EMC Directive or the EMC law is met. – If devices which do not meet the CE requirement with regard to noise immunity EN 61000-4-2 are actuated near the system, these devices can be affected electromagnetically by the system.
Structure	<ul style="list-style-type: none"> ● Connect device to the earthed mounting plate: <ul style="list-style-type: none"> – Mounting plates with an electroconductive surface (zinc-coated or stainless steel) allow for continuous contacting. – Coated plates are not suitable for an EMC-compliant installation. ● If you use several mounting plates: <ul style="list-style-type: none"> – Connect mounting plates to each other on a large surface and in a conductive manner (e.g. by means of copper strips). ● When installing the cables, observe a spatial separation of signal and mains cables. ● Route the cables as near to the reference potential as possible. Freely suspended cables act like aerials.
Shielding	<ul style="list-style-type: none"> ● Preferably only use cables with a braid. ● The coverage of the shield should be more than 80%. ● In the case of data lines for a serial coupling, always use metallic or metallised plugs. Connect the shield of the data line on the connector shell.
Earthing	<ul style="list-style-type: none"> ● Earth all metallically conductive components by the use of corresponding cables from a central earthing point (PE rail). ● Comply with the minimum cross-sections defined in the safety instructions: <ul style="list-style-type: none"> – With regard to EMC, however, not the cable cross-section, but the surface of the cable and of the extensive contacting is decisive.

6.3 Connecting the supply and peripheral devices

6.3.1 Preliminary works

For connecting the supply and the peripherals, the screen must be fitted into the mounting frame and hinged down.

**Stop!****Screen may fall down**

If the screen is not screwed together with the mounting frame it may fall down.

Possible consequences:

- ▶ The screen is damaged.
- ▶ Injuries by the falling device.

Protective measures:

- ▶ Secure screen against falling down.

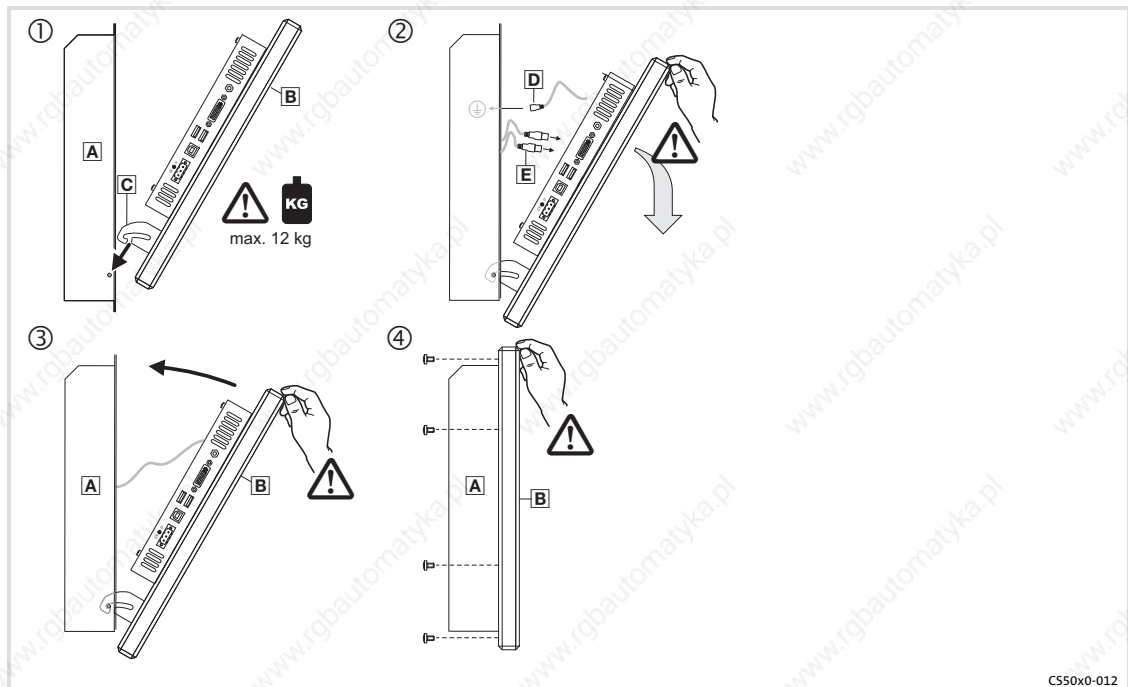

CS50x0-012

How to proceed:

1. Place **C** screen **B** in the mounting frame **A** using the attachment and secure it against falling down during the following worksteps.
2. Plug in the connection cable **B**.
 - Plug in the PE connection cable **D** on the mounting frame
 - Plug in other connection cables **E** (supply, DVI, USB).
3. Retract screen.
4. Screw screen to the mounting frame.
Always fit all screws.

6.3.2 Terminal diagram supply

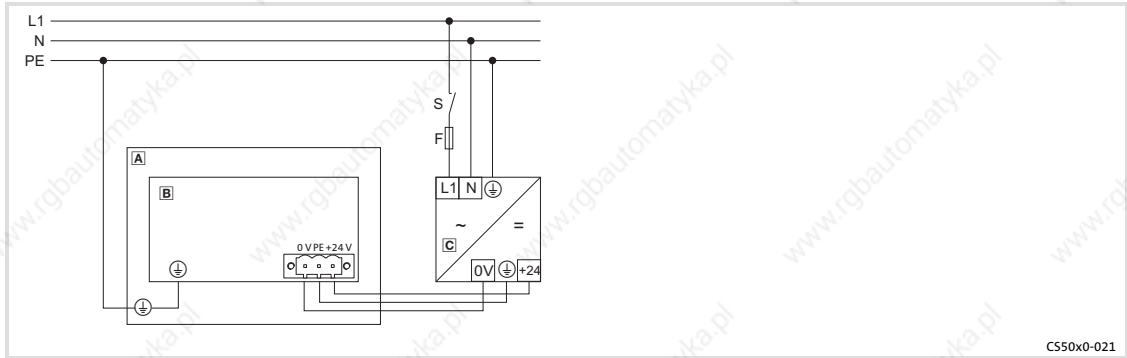

- A Mounting frame
- B Screen
- C Power supply unit

CS50x0-021



Note!

Observe the max. permissible input voltage.
Professionally fuse the device on the input side against voltage variations and voltage peaks.

6.3.3 24 V connection

	Description	Connection type	Cable type
<p>IPC001</p>	DC 24 V connection	3-pole Phoenix Combicon socket	Cable (conductor cross-section max. 2.5 mm ²) with Phoenix Combicon plug, MSTB 2.5 / 3-STF-5.08
<p>IPC001</p>	PE connection	M4 threaded bolt	Separate earthing conductor (min. 2.5 mm ²) with ring cable lug

6.3.4 DVI interface

**Note!**

Only use the DVI cable from the scope of supply or one of the DVI cables specified in the following table, featuring a maximum length of 2 m. Otherwise a faultless signal transmission is not guaranteed.

Greater distances can be covered with the following Lenze accessories:

2 ... 5 m: "DVI/USB" cable set

5 ... 35 m: DVI/USB extender V4

	Description	Connection type	Cable type
 IPC001	DVI interface	DVI-D socket	DVI-D single link (18+1) DVI-D double link (24+1)

6.3.5 USB interface

	Description	Connection type	Cable type
 IPC001	USB 2.0 host connection Max. load: 5 V/500 mA	USB-A socket	USB cable with USB-A plug

	Description	Connection type	Cable type
 DVI/USB-010	USB device connection	USB-B socket	USB cable with USB-B plug

6.3.6 USB interface on the front face (option)



	Description	Connection type	Cable type
 EL100-013	USB 2.0 host connection with IP 65 cover Max. load: 5 V/500 mA	USB-A socket	USB cable with USB-A plug

**Note!**

If you use USB interfaces routed to the outside, the data integrity cannot be guaranteed. On the "PC based Automation" DVD you'll find the "FM Tool" software which can be used to deactivate the front USB interface if it is not needed.

6.3.7 Mounting frame connecting plate (option)

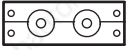
You can replace the blanking plate in the mounting frame by a connecting plate which serves to connect further interfaces. The following interfaces are available:

	Description	Connection type	Cable type
 EL100-015	Universalkupplung, 2-fach (KDL-2, zur Kabeldurchführung der Tastatur CSB MF2)	-	-
 EL100-017	USB-Host-Anschluss mit Abdeckkappe IP 65, 1-fach- oder 2-fach Max. load: 5 V/500 mA	USB-A-Buchse	USB-Kabel mit USB-A-Stecker

6

Electrical installation

Assignment of the operator console connector board (only CS 5010 DVI)

6.4

Assignment of the operator console connector board (only CS 5010 DVI)

The adapter board is located within the mounting frame of the Command Station. The scope of supply includes four connector plugs that are plugged on the basic housings of the adapter board in position X1 to X4.

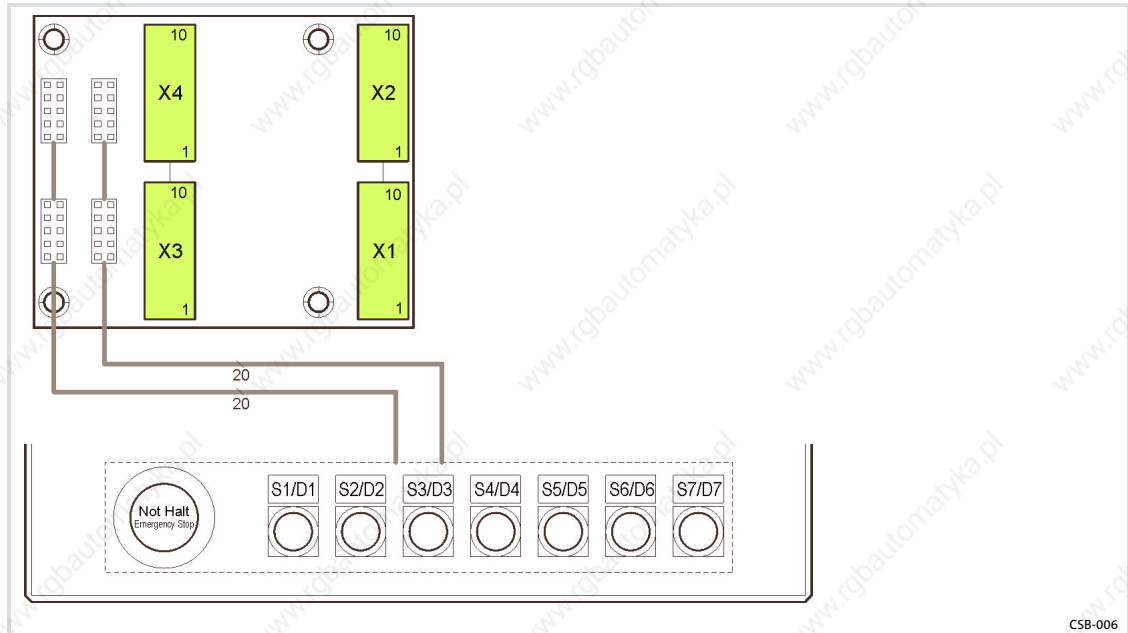

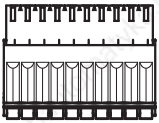
	Description	Connection type	Cable type
	Connections for wiring the control/display elements of the control desk	10-pole Phoenix Combicon socket with spring pressure connection, type FK-MC 0.5/10-ST-2.5	Flexible due to wire end ferrule, conductor cross-section 0.14 ... 0.5 mm ²

Contact	Assignment			
	X1	X2	X3	x4
1	Key voltage S1 ... S7 (e. g. +24 V)	LED-GND (LED 1 ... 7)	Key voltage S1 ... S7 (e. g. +24 V)	N.C.
2	S 1.1	LED D1 anode	S 1.2	N.C.
3	S 2.1	LED D2 anode	S 2.2	N.C.
4	S 3.1	LED D3 anode	S 3.2	N.C.
5	S 4.1	LED D4 anode	S 4.2	N.C.
6	S 5.1	LED D5 anode	S 5.2	N.C.
7	S 6.1	LED D6 anode	S 6.2	N.C.
8	S 7.1	LED D7 anode	S 7.2	N.C.
9	Emergency stop 1.1	Emergency stop 2.1	Potential I: S1/S5	Potential III: S3/S7
10	Emergency stop 1.2	Emergency stop 2.2	Potential II: S2/S6	Potential IV: S4

7 Operation

7.1 Important notes



Stop!

Sensitive touchscreen surface

The touchscreen foil is very sensitive to external forces and can be damaged by improper handling.

Possible consequences:

- ▶ The touchscreen foil becomes damaged, scratched or dull.

Protective measures:

- ▶ Avoid contact of the touchscreen foil with pointed or hard objects.
- ▶ Always use a touch pen or your fingers to operate the touchscreen. Never use objects such as ballpoint pens, pencils, etc.
- ▶ When removing dirt and fingerprints, observe the notes given in the chapter "Cleaning" (📖 47).

7

Operation

Controls and displays

Command Station CS 5000 DVI and CS 9000 DVI

7.2

Controls and displays

7.2.1

Command Station CS 5000 DVI and CS 9000 DVI

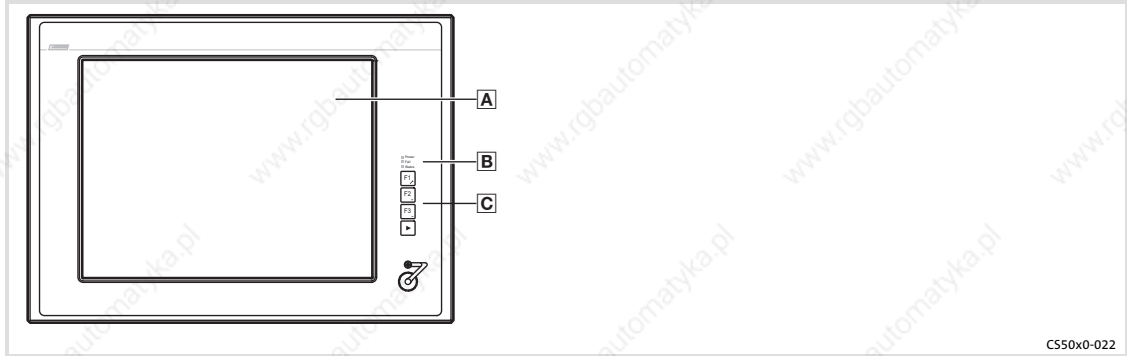

Pos.	Designation	Function	
		Standard mode	Service mode
	Switch on mode:		Press "▶" for 4 s
	Switch off mode:		Press "▶" or wait for 35 s
A	Display	Application-dependent	
B	Status LEDs	Power (green): <ul style="list-style-type: none"> ● Is ON when the supply voltage is present. Fail (red): <ul style="list-style-type: none"> ● Is On when a power supply failure has occurred. ● Is blinking when the screen signal is missing. Status (yellow): <ul style="list-style-type: none"> ● Application-dependent 	
C	Function keys	F1 ... F3: Send key code for Shift-F1 ... Shift-F3	Tool: Application-dependent +: Increase screen brightness -: Reduce screen brightness

7.2.2 Command Station CS 5010 DVI

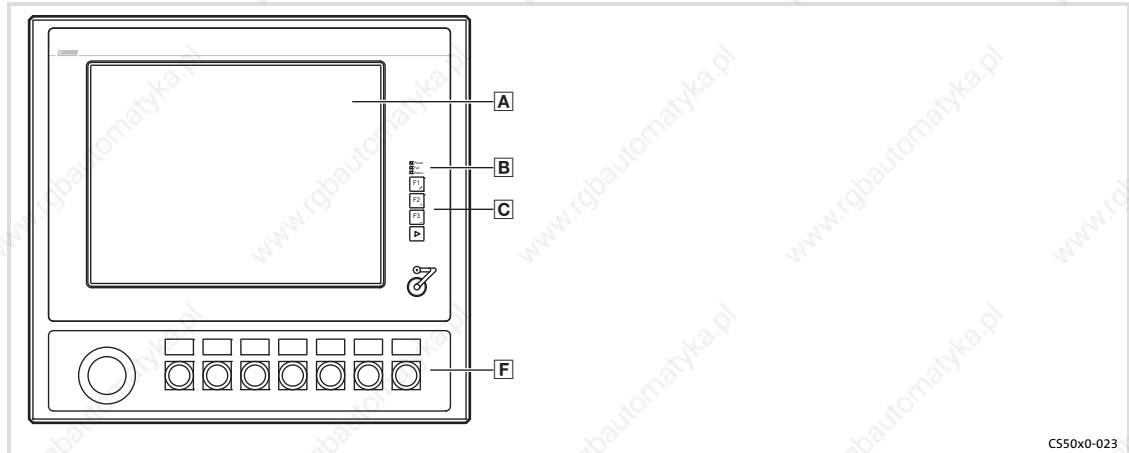

Pos.	Designation	Function	
		Standard mode	Service mode
	Switch on mode:		Press "▶" for 4 s
	Switch off mode:		Press "▶" or wait for 35 s
A	Display	Application-dependent	
B	Status LEDs	Power (green): ● Is ON when the supply voltage is present. Fail (red): ● Is On when a power supply failure has occurred. ● Is blinking when the screen signal is missing. Status (yellow): ● Application-dependent	
C	Function keys	F1 ... F3: Send key code for Shift-F1 ... Shift-F3	Tool: Application-dependent +: Increase screen brightness -: Reduce screen brightness
F	Control element	Application-dependent	

7.2.3

Command Station CS 5050 DVI

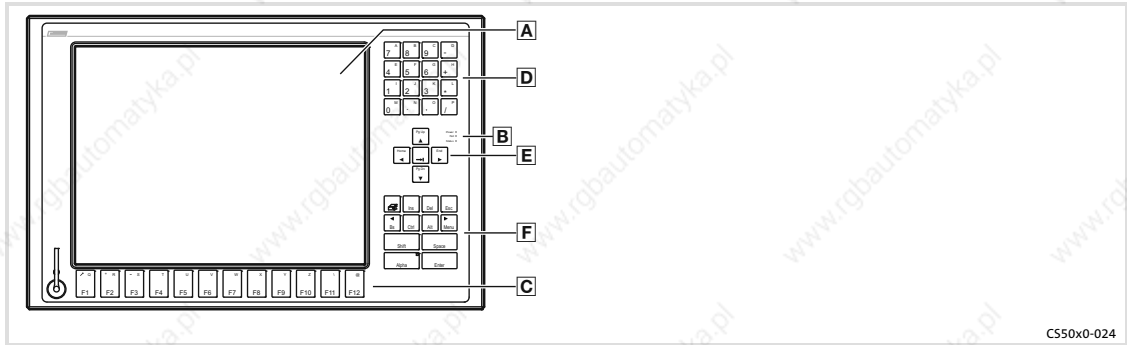

CS50x0-024

Pos.	Designation	Function		
		Standard mode	Alpha mode	Service mode
	Switch on mode:		Press "alpha key" (LED is on)	Press "menu key"
	Switch off mode:		Press "alpha key" (LED is off)	Press "menu key" or wait for 35 s
A	Display	Application-dependent		
B	Status LEDs	Power (green): <ul style="list-style-type: none"> Is ON when the supply voltage is present. Fail (red): <ul style="list-style-type: none"> Is ON when a power supply failure has occurred Is blinking when the screen signal is missing. Status (yellow): <ul style="list-style-type: none"> Indicates access to a storage medium. 		
C	Function keys	F1 ... F12: Send key code for Shift-F1 ... Shift-F12	F1 ... F12: Send key codes for "Q" ... "@"	Tool: Application-dependent + : Increase screen brightness - : Reduce screen brightness
D	Numeric keypad	Send key codes for "0" ... "9" and calculation operators	Send key codes for "A" ... "P"	Functionality same as in standard/alpha mode
E	Cursor keys	Without "Shift" key: Move cursor/marker in steps and set tab With "Shift" key: Move cursor/marker to the beginning/end or page by page		Functionality same as in standard/alpha mode
F	Control keys	Standard functions of a MF2 keyboard (For "alpha" and "menu" see "Switch on/off mode")		Functionality same as in standard/alpha mode

7.2.4

Command Station CS 5070 DVI

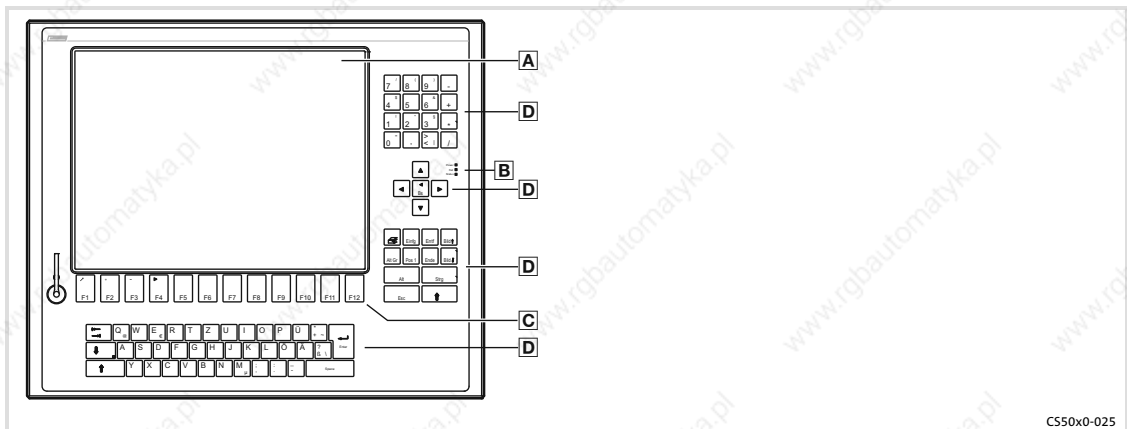

CS50x0-025

Pos.	Designation	Function	
		Standard mode	Service mode
	Switch on mode:		Press "► (F4)" for 4 s
	Switch off mode:		Press "► (F4)" or wait for 35 s
A	Display	Application-dependent	
B	Status LEDs	Power (green): <ul style="list-style-type: none"> ● Is ON when the supply voltage is present. Fail (red): <ul style="list-style-type: none"> ● Is ON when a power supply failure has occurred. ● Is blinking when the screen signal is missing. Status (yellow): <ul style="list-style-type: none"> ● Indicates access to a storage medium. 	
C	Function keys	F1 ... F12: Send key code for Shift-F1 ... Shift-F12	Tool: Application-dependent +: Increase screen brightness -: Reduce screen brightness
D	MF2 keys	Standard function of a MF2 keyboard	

**Stop!****Short circuit and static discharge**

The device contains components which are endangered in the case of short circuit or static discharge.

Possible consequences:

- ▶ The device or parts of it will be destroyed.

Protective measures:

- ▶ Always switch off the voltage supply when working on the device. This particularly applies:
 - Before connecting / disconnecting connectors.
 - Before plugging in / plugging out modules.
- ▶ All persons handling printed circuit boards have to take account of ESD measures.
- ▶ Contacts of plug connectors must not be touched.
- ▶ Printed circuit boards may be touched only at places free from electrical contacts and may be placed only on appropriate materials (e.g. on ESD packaging or conductive foam material).
- ▶ Printed circuit boards may only be transported and stored in ESD packaging.

8.1**Regular checks**

The device is free of maintenance. Nevertheless, visual inspections should be carried out at regular intervals which must not be too long, depending on the ambient conditions.

Please check the following:

- ▶ Does the environment of the device meet the operating conditions specified in the Technical data?
- ▶ Is the heat dissipation of the device not impeded by dust or dirt?
- ▶ Are the mechanical and electrical connections o.k.?

8.2

Cleaning

**Stop!****Sensitive surfaces and components**

The device can be damaged if it is not appropriately cleaned.

Possible consequences:

- ▶ The housing or the screen gets scratched or dull if you use alcoholic, solvent-containing or scouring cleaning agents.
- ▶ Electrical components can be damaged ...
 - by a short circuit caused by humidity.
 - by static discharge.

Protective measures:

- ▶ Observe the following notes.
-
- ▶ Before cleaning, disconnect the device from the power supply (and the optionally UPS power supply) as otherwise unintentional commands may be activated via the touchscreen, for example a response of the control.
 - ▶ Clean the device front (screen and frame) as follows:
 - Use a clean, lint-free and soft cloth.
 - Moisten the cloth with the detergent. Do not spray the detergent directly on the device.
 - Only use water with a fluid addition as detergent or a detergent declared especially for flat screens.
 - ▶ Clean the device rear side (chassis) as follows:
 - Use a stainless steel cleaner and a clean, lint-free and soft cloth.
 - Avoid contact of the cleaner with the seals.

8.3

Repair

For the repair of the monitor panel, the screen must be removed and placed flat on a clean, padded work surface.

8.3.1

Removing and mounting the screen

**Stop!****Screen may fall down**

If the screen is not screwed together with the mounting frame it may fall down.

Possible consequences:

- ▶ The screen is damaged.
- ▶ Injuries by the falling device.

Protective measures:

- ▶ Secure screen against falling down.

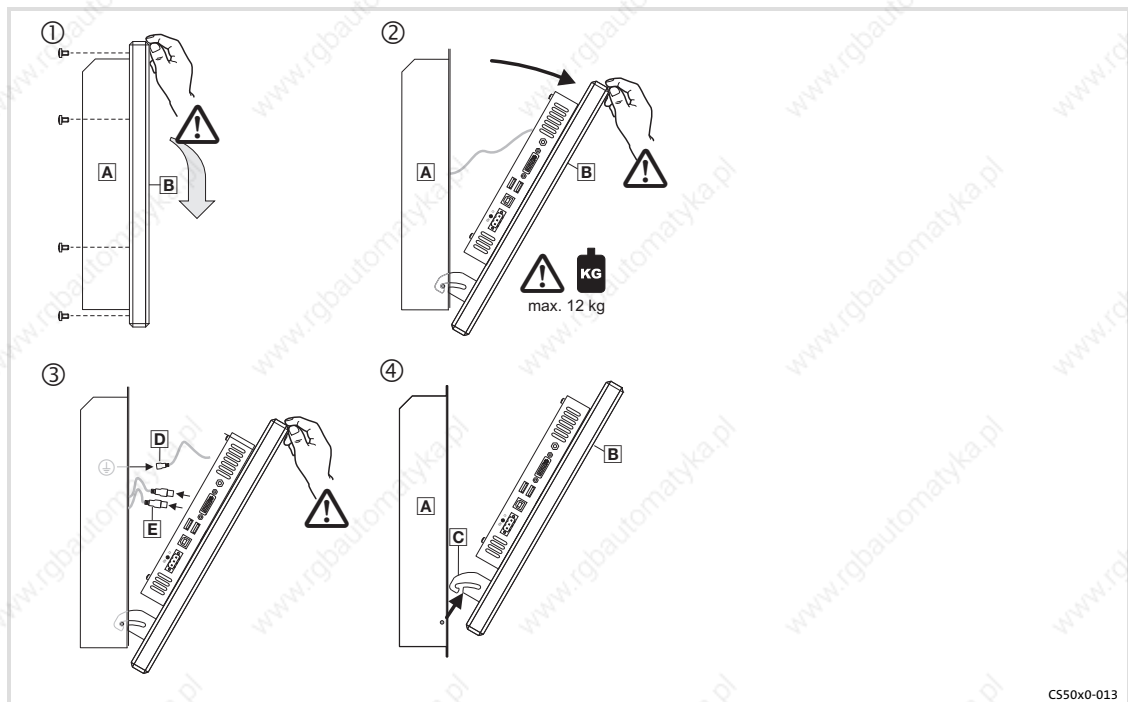
Dismounting

- A Mounting frame
- B Screen
- C Attachment
- D PE connecting cable
- E Other connecting cables

Mounting

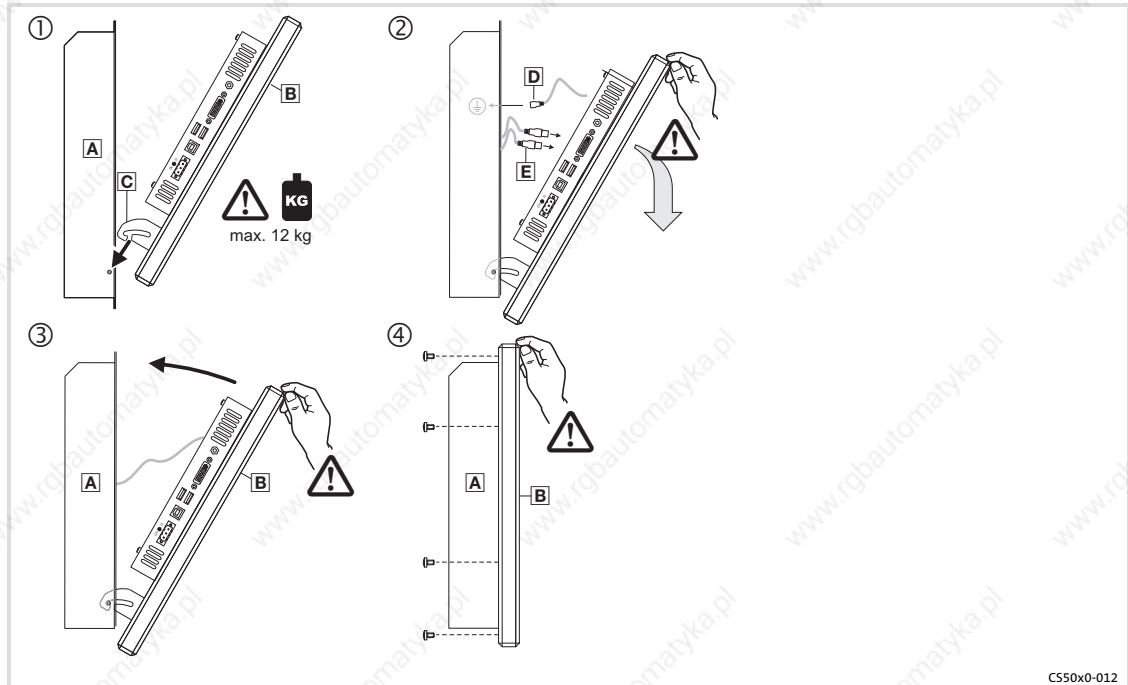

- A** Mounting frame
- B** Screen
- C** Attachment
- D** PE connecting cable
- E** Other connecting cables

8.3.2

Fuse change

**Stop!****Damage of the device by non-permissible fuse possible**

The baseboard in the device is protected by a fuse which will be damaged if the supply voltage applied is too high.

Possible consequences:

- ▶ The device can be damaged if a non-approved fuse is installed.

Protective measures:

- ▶ The fuse may only be replaced by an approved type.

Approved types:

- ▶ Wickmann No. 181, 4 A, 250 V DC

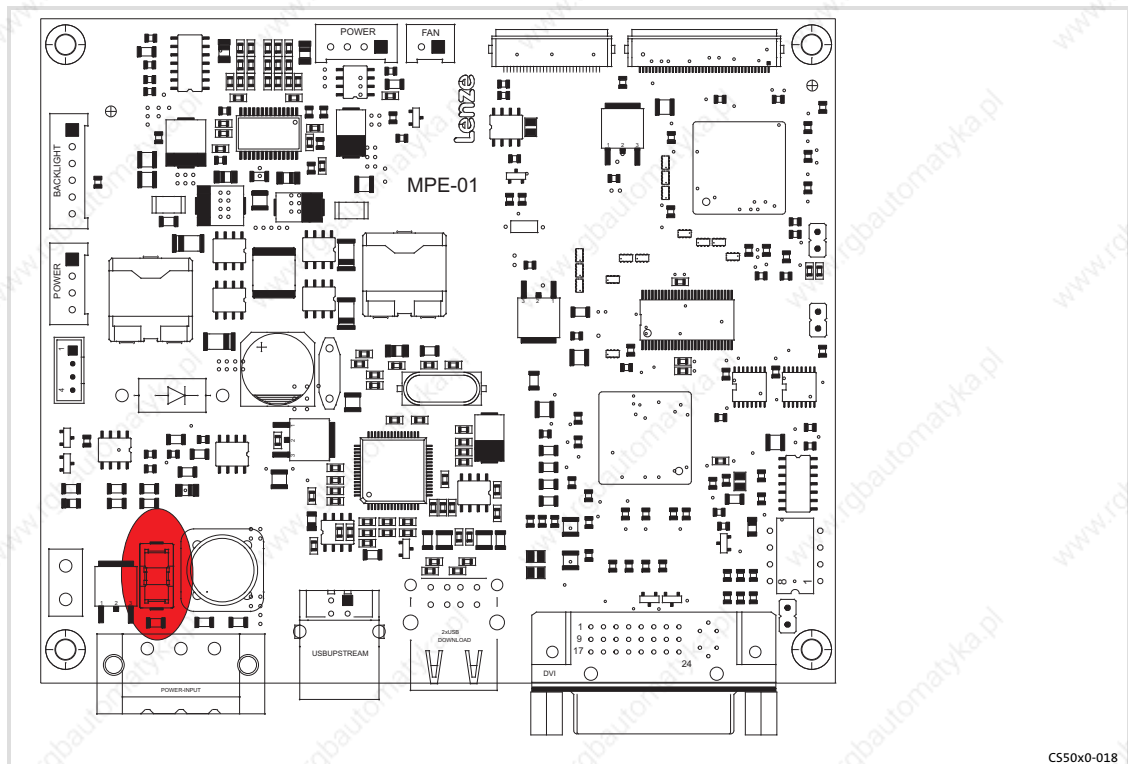

Fig. 8-1 Position of the fuse on the baseboard

9 Index

A

Adapter board, Assignment, 40

Add-on component

- dimensions, 25
- version, 24
- weight, 24

Ambient conditions

- climatic, 22
- Site altitude, 22
- Chemical resistance, 22

Anzeigeelemente

- CS 5000 DVI, 42
- CS 5010 DVI, 43
- CS 5050 DVI, 44
- CS 5070 DVI, 44
- CS 9000 DVI, 42

Application as directed, 14

Approbation, 21

B

Bedienelemente

- CS 5000 DVI, 42
- CS 5010 DVI, 43
- CS 5050 DVI, 44
- CS 5070 DVI, 44
- CS 9000 DVI, 42

C

Chemical resistance, 22

Class of protection, 21

Cleaning, 47

Conformity, 21

Control elements, CSB 7/14, 19

Control/Display elements

- Labelling, 32
- Wiring, 40

Controls, 18, 42

D

Danger

- Short circuit, 34, 46
- Static discharge, 34, 46

Definition of notes used, 7

Device

- control/display elements, CSB 7/14, 19
- overview, 18
- radio interference, 10
- version, 24
- weight, 24

Display, 23

Display elements, CSB 7/14, 19

Displays, 18, 42

Disposal, 10

DVI port, 38

E

Electrical data, 23

Electrical installation, 33

- EMC-compliant wiring, 35
- Mains, 37
- monitor, 38
- Operator console CSB 7/14, 40
- Terminal diagram, 37
- UPS, 40
- USB
 - front panel, 38
 - internal, 38
- USB connection, 38

**Elektrische Installation,
Montagewanne-Anschlussplatte, 39**

EMC, 21

- earthing, 35
- shielding, 35
- structure, 35

EMC-compliant wiring, 35

Enclosure, 21

Ergonomics, 10

Error behaviour, 10

F

Fault, behaviour, 10

Fuse, change, 50

G

General data, 21

Gerät, Bedien- und Anzeigeelemente

- CS 5000 DVI, 42
- CS 5010 DVI, 43
- CS 5050 DVI, 44
- CS 5070 DVI, 44
- CS 9000 DVI, 42

I

Identification, 17

Installation, CE-typical drive system

- earthing, 35
- shielding, 35
- structure, 35

Installation, electrical, 33

Installation, mechanical, 26

L

Load capacity, 22

M

Mains connection, 37

Maintenance, 46

- Cleaning, 47
- Fuse, 50
- Regular checks, 46
- Repair, 48

Mechanical data, 24

- version
 - add-on component, 24
 - device, 24
- weight
 - add-on component, 24
 - device, 24

Mechanical installation, 26

Mechanical load capacity, 22

Monitor connection, 38

Monitor port, 38

**Montagewanne, Universalkupplung,
39**

Montagewanne-Anschlussplatte, 39

Mounting conditions, Mounting place, 22

Mounting frame, remove, 27

Mounting steps

- Change labelling, 32
- removing the mounting frame, 27
- support arm mounting with add-on components, 29 without add-on components, 28
- wall mounting with add-on components, 31 without add-on components, 30

Mounting the screen, 48

N

Nameplate, 17

Nameplate data, 17

Noise emission, 21

Noise immunity, 21

Notes, definition, 7

O

Operating conditions, 22

- Mounting conditions, Mounting place, 22

Operation, 41

Overview, 18

P

Product description, 13

- application as directed, 14

R

Radio interference, 10

Regular checks, 46

Removing the screen, 48

Repair, 48

S

Safety, 21

Safety instructions, 8

- application as directed, 14
- definition, 7
- layout, 7

Scope of supply, 13

Screen, 23

Shielding, EMC, 35

Short circuit, 34, 46

Site altitude, 22

Static discharge, 34, 46

Supply, 23

Support arm mounting

- with add-on components, 29
- without add-on components, 28

T

Technical data, 21

- Electrical data, 23
- General data, 21
- mechanical data, 24
- Operating conditions, 22

Temperatures, 22

Terminal diagram, 37

Touchscreen, 23

Type code, 17

- finding, 17

U

Universalkupplung, 39

UPS connection, 40

USB connection, 38

- front panel, 38
- internal, 38

V

Validity, documentation, 5

Version

- add-on component, 24
- device, 24

Voltage supply, 23

W

Wall mounting

- with add-on components, 31
- without add-on components, 30

Weight

- add-on component, 24
- device, 24



© 02/2014

Lenze Automation GmbH
Postfach 10 13 52, D-31763 Hameln
Hans-Lenze-Str. 1, D-31855 Aerzen
Germany



+49 5154 82-0



+49 5154 82-2800



lenze@lenze.com



www.lenze.com

Service

Lenze Service GmbH
Breslauer Straße 3, D-32699 Extertal

Germany



008000 2446877 (24 h helpline)



+49 5154 82-1112



service@lenze.com



BA_CS9000DVI ■ 13458294 ■ EN ■ 4.0 ■ TD06

10 9 8 7 6 5 4 3 2 1