

**SPECIFICATIONS**

Item	Basic Model No.	Triple beam adjustable range reflective							
		40 mm 1.575 in type			200 mm 7.874 in type			700 mm 27.559 in type	
		Visible light	Low hysteresis	Visible light	Low hysteresis	Visible light	Low hysteresis		
		<b>MQ-W3A□</b>	<b>MQ-W3AR□</b>	<b>MQ-WN3A□</b>	<b>MQ-W20A□</b>	<b>MQ-W20AR□</b>	<b>MQ-WN20A□</b>	<b>MQ-W70A□</b>	<b>MQ-WN70A□</b>
Sensing distance (rated)		40 mm 1.575 in with white non-glossy paper (10 × 10 mm 0.394 × 0.394 in)			200 mm 7.874 in with white non-glossy paper (20 × 20 mm 0.787 × 0.787 in)			700 mm 27.559 in with white non-glossy paper (75 × 75 mm 2.953 × 2.953 in)	
Setting range (optimum)		20 to 40 mm 0.787 to 1.575 in with white non-glossy paper (10 × 10 mm 0.394 × 0.394 in)			40 to 200 mm 1.575 to 7.874 in with white non-glossy paper (20 × 20mm 0.787 × 0.787 in)			200 to 700 mm 7.874 to 27.559 in with white non-glossy paper (75 × 75 mm 2.953 × 2.953 in)	
Sensing object		Opaque or translucent object (Note 2)							
Hysteresis (Note 3)		10 % or less of operation distance (with standard sensing object)	5 % or less of operation distance (with standard sensing object)	20 % or less of operation distance (with standard sensing object)	10 % or less of operation distance (with standard sensing object)	20 % or less of operation distance (with standard sensing object)	10 % or less of operation distance (with standard sensing object)	20 % or less of operation distance (with standard sensing object)	10 % or less of operation distance (with standard sensing object)
Supply voltage		9.6 to 30 V DC							
Current consumption		30 mA or less							
Output		NPN open-collector transistor • Maximum sink current: 100 mA • Applied voltage: 30 V DC or less (between output and 0 V) • Residual voltage: 1.2 V or less (at 100 mA sink current)							
Output operation		Selectable either Light-ON or Dark-ON by the control input							
Response time		2 ms or less (Response frequency: 250 Hz or more)							
Operation indicator		Red LED (lights up under light received condition)							
Stability indicator		Red LED (lights up under stable sensing condition)							
Distance adjuster		Continuously variable adjuster							
Environmental resistance	Protection	IP67 (IEC)							
	Ambient temperature	-25 to +55 °C -13 to +131 °F (No dew condensation or icing allowed), Storage: -25 to +55 °C -13 to +131 °F							
	Ambient humidity	85 % RH or less, Storage: 85 % RH or less							
	Ambient illuminance	Incandescent light: 10,000 lx or less at the light-receiving face							
	Voltage withstandability	500 V AC for one min. between all supply terminals connected together and enclosure							
	Insulation resistance	20 MΩ, or more, with 500 V DC megger between all supply terminals connected together and enclosure							
	Vibration resistance	10 to 55 Hz frequency, 1.5 mm 0.059 in amplitude in X, Y and Z directions for two hours each							
Shock resistance	1,000 m/s <sup>2</sup> acceleration (100 G approx.) in X, Y and Z directions for six times each								
Emitting element (modulated)		Infrared LED	Red LED	Infrared LED	Red LED	Infrared LED	Red LED	Infrared LED	
Material		Enclosure: Die-cast zinc alloy							
Cable		4-core cable, 2 m 6.562 ft long							
Cable extension		Extension up to total 100 m 328.084 ft is possible with 0.3 mm <sup>2</sup> , or more, cable.							
Accessory		Mounting bracket: 1 set							

Notes: 1) Where measurement conditions have not been specified precisely, the conditions use were an ambient temperature of +23 °C +73.4 °F.  
 2) Make sure to confirm detection with an actual sensor before use.  
 3) This value is from the sensing distance (rated). The standard sensing object is non-glossy paper described in the "Sensing distance (rated)" item.

**I/O CIRCUIT AND WIRING DIAGRAMS**

**I/O circuit diagram**

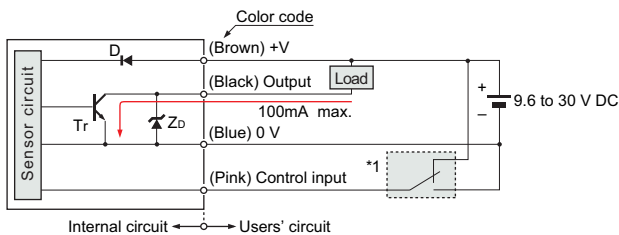

Symbols ... D : Reverse supply polarity protection diode  
 Zd: Surge absorption zener diode  
 Tr : NPN output transistor

**Wiring diagram**

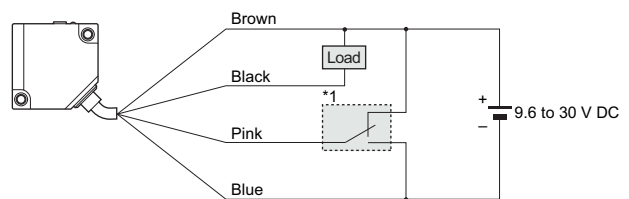

\* 1: Selecting output operation by connecting control input wire (pink)

Processing	Output operation
Connected to +V	Light-ON
Connected to 0 V	Dark-ON

FIBER SENSORS

LASER SENSORS

PHOTO-ELECTRIC SENSORS

MICRO PHOTO-ELECTRIC SENSORS

AREA SENSORS

LIGHT CURTAINS/ SAFETY COMPONENTS

PRESSURE / FLOW SENSORS

INDUCTIVE PROXIMITY SENSORS

PARTICULAR USE SENSORS

SENSOR OPTIONS

SIMPLE WIRE-SAVING UNITS

WIRE-SAVING SYSTEMS

MEASURE-MENT SENSORS

STATIC ELECTRICITY PREVENTION DEVICES

LASER MARKERS

PLC

HUMAN MACHINE INTERFACES

ENERGY CONSUMPTION VISUALIZATION COMPONENTS

FA COMPONENTS

MACHINE VISION SYSTEMS

UV CURING SYSTEMS

Selection Guide

Amplifier Built-in

Power Supply Built-in

Amplifier-separated

CX-400

CY-100

EX-10

EX-20

EX-30

EX-40

CX-440

EQ-30

EQ-500

**MQ-W**

RX-LS200

RX

RT-610

**SENSING CHARACTERISTICS (TYPICAL)**

**40 mm 1.575 in Type**

**Sensing field**

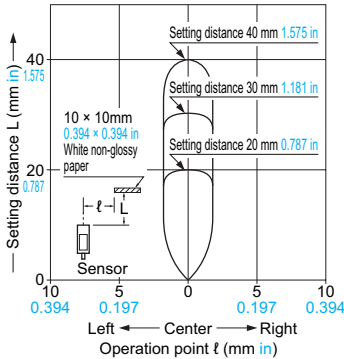

**Correlation between sensing object size and sensing range**

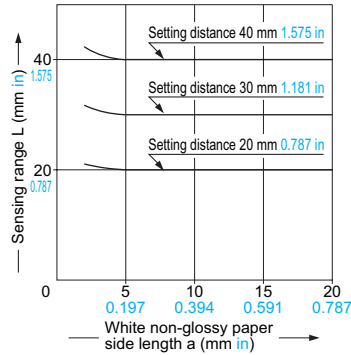

These curves show the characteristics with the maximum sensing range set to 40 mm 1.575 in, 30 mm 1.181 in and 20 mm 0.787 in, with white non-glossy paper (10 × 10 mm 0.394 × 0.394 in).

**Correlation between material and sensing range**

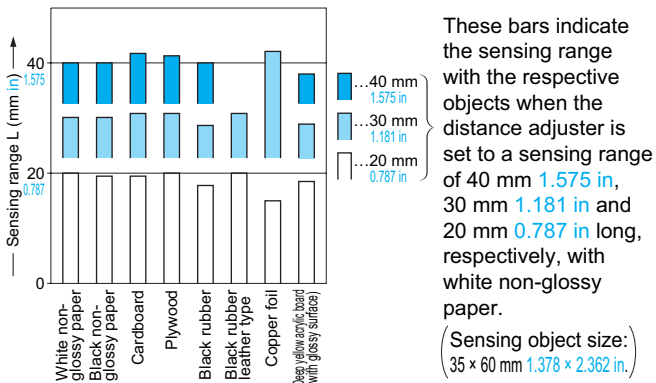

**Emitted beam**

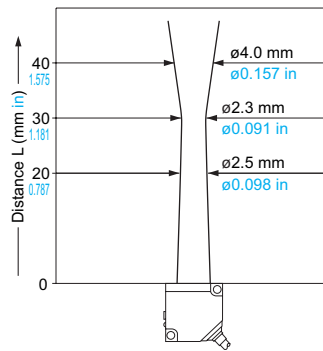

**200 mm 7.874 in Type**

**Sensing field**

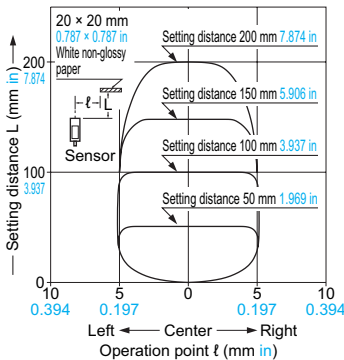

**Correlation between sensing object size and sensing range**

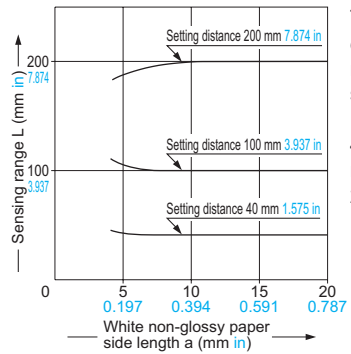

These curves show the characteristics with the maximum sensing range set to 200 mm 7.874 in, 100 mm 3.937 in and 40 mm 1.575 in, with white non-glossy paper (20 × 20 mm 0.787 × 0.787 in).

**Correlation between material and sensing range**

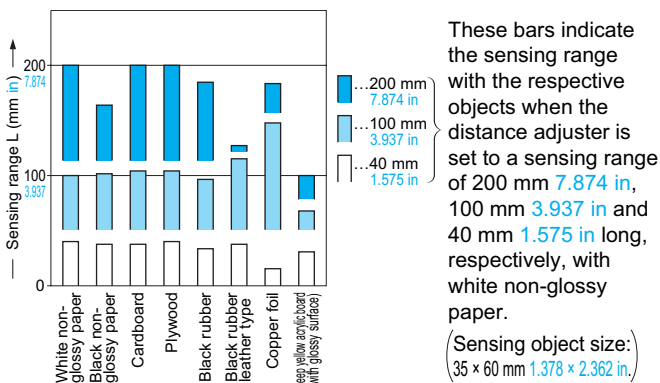

**Emitted beam**

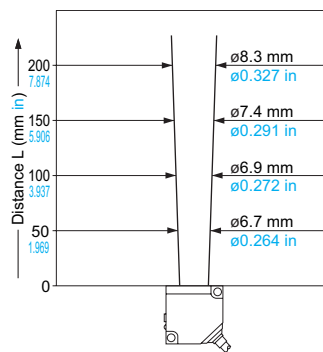

FIBER SENSORS

LASER SENSORS

PHOTO-ELECTRIC SENSORS

MICRO PHOTO-ELECTRIC SENSORS

AREA SENSORS

LIGHT CURTAINS / SAFETY COMPONENTS

PRESSURE / FLOW SENSORS

INDUCTIVE PROXIMITY SENSORS

PARTICULAR USE SENSORS

SENSOR OPTIONS

SIMPLE WIRE-SAVING UNITS

WIRE-SAVING SYSTEMS

MEASUREMENT SENSORS

STATIC ELECTRICITY PREVENTION DEVICES

LASER MARKERS

PLC

HUMAN MACHINE INTERFACES

ENERGY CONSUMPTION VISUALIZATION COMPONENTS

FA COMPONENTS

MACHINE VISION SYSTEMS

UV CURING SYSTEMS

Selection Guide

Amplifier Built-in

Power Supply Built-in

Amplifier-separated

CX-400

CY-100

EX-10

EX-20

EX-30

EX-40

CX-440

EQ-30

EQ-500

**MQ-W**

RX-LS200

RX

RT-610