

PROXIMITY/AMBIENT LIGHT SENSOR IC WITH I²C INTERFACE

Features

- Integrated infrared proximity detector
 - Proximity detection adjustable from under 1 cm up to 200 cm
 - Three independent LED drivers
 - 15 current settings from 5.6 mA to 360 mA for each LED driver
 - 25.6 μ s LED driver pulse width
 - 50 cm proximity range with single pulse (<3 klx)
 - 15 cm proximity range with single pulse (>3 klx)
 - Operates at up to 128 klx (direct sunlight)
 - High reflectance sensitivity < 1 μ W/cm²
 - High EMI immunity without shielded packaging
- Integrated ambient light sensor
 - 100 mlx resolution possible, allowing operation under dark glass
 - 1 to 128 klx dynamic range possible across two ADC range settings
- Accurate lux measurements with IR correction algorithm
- Industry's lowest power consumption
 - 1.71 to 3.6 V supply voltage
 - 9 μ A average current (LED pulsed 25.6 μ s every 800 ms at 180 mA plus 3 μ A Si114x supply)
 - < 500 nA standby current
 - 25.6 μ s LED "on" time keeps total power consumption duty cycle low without compromising performance or noise immunity
- Internal and external wake support
- Built-in voltage supply monitor and power-on reset controller
- Serial communications
 - Up to 3.4 Mbps data rate
 - Slave mode hardware address decoding (0x5A)
- Small-outline 10-lead 2x2 mm QFN Temperature Range
 - -40 to +85 °C

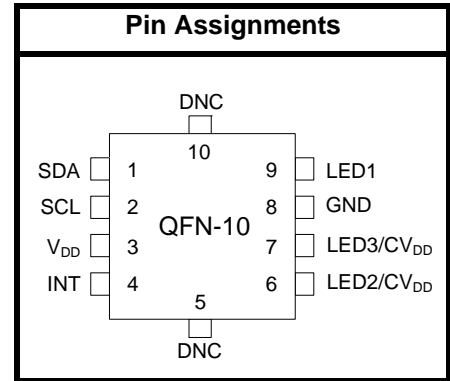

Applications

- Handsets
- Heart rate monitoring
- Pulse oximetry
- Wearables
- Audio products
- Security panels
- Tamper detection circuits
- Dispensers
- Valve controls
- Smoke detectors
- Touchless switches
- Touchless sliders
- Occupancy sensors
- Consumer electronics
- Industrial automation
- Display backlighting control
- Photo-interrupters

Description

The Si1141/42/43 is a low-power, reflectance-based, infrared proximity and ambient light sensor with I²C digital interface and programmable-event interrupt output. This touchless sensor IC includes an analog-to-digital converter, integrated high-sensitivity visible and infrared photodiodes, digital signal processor, and one, two, or three integrated infrared LED drivers with fifteen selectable drive levels. The Si1141/42/43 offers excellent performance under a wide dynamic range and a variety of light sources including direct sunlight. The Si1141/42/43 can also work under dark glass covers. The photodiode response and associated digital conversion circuitry provide excellent immunity to artificial light flicker noise and natural light flutter noise. With two or more LEDs, the Si1142/43 is capable of supporting multiple-axis proximity motion detection. The Si1141/42/43 devices are provided in a 10-lead 2x2 mm QFN package and are capable of operation from 1.71 to 3.6 V over the -40 to +85 °C temperature range.

Si1141/42/43

Functional Block Diagram

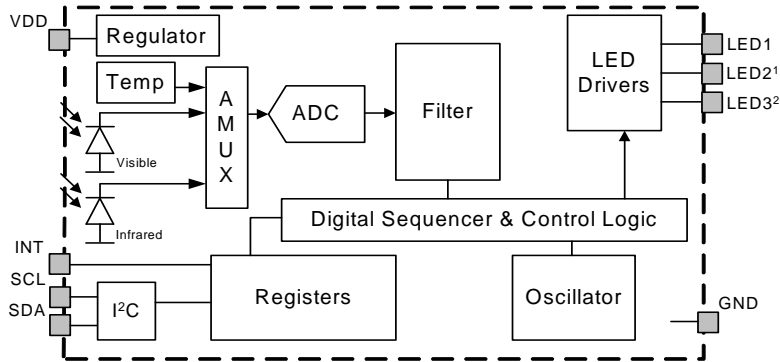

1. Si1142 and Si1143 only. Must be tied to V_{DD} with Si1141.
2. Si1143 only. Must be tied to V_{DD} with Si1141 and Si1142.

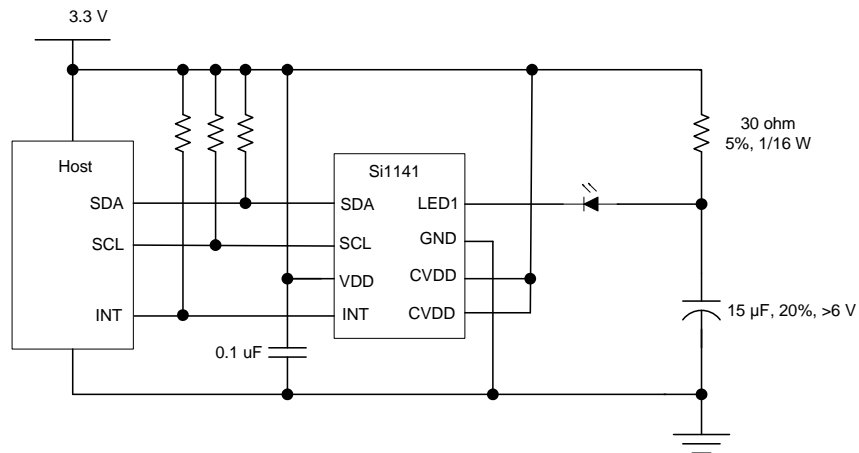

Figure 1. Si1141 Basic Application

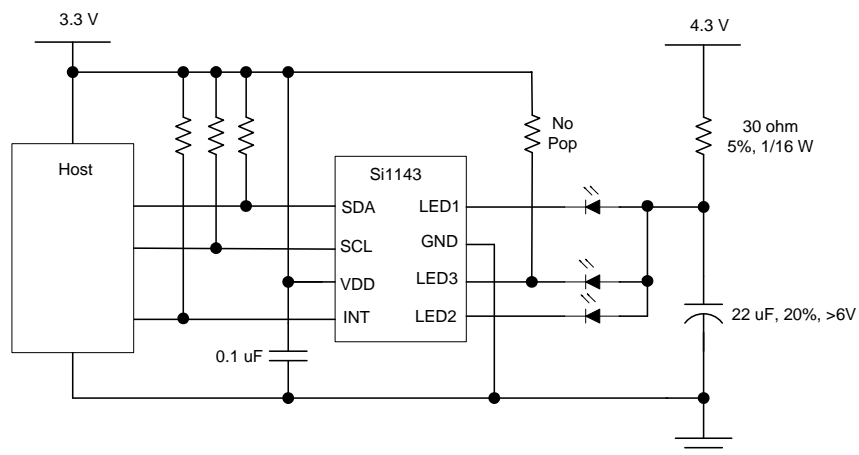

Figure 2. Si1143 Application with Three LEDs and Separate LED Power Supply

Note: For more application examples, refer to “AN498: Si114x Designer’s Guide”.