



HEIDENHAIN



Rotary Encoders

April 2005



Rotary encoders with mounted stator coupling



Rotary encoders for separate shaft coupling

The catalogs for

- Angle encoders
- Exposed linear encoders
- Sealed linear encoders
- Position encoders for servo drives
- HEIDENHAIN subsequent electronics

are available upon request.

This catalog supersedes all previous editions, which thereby become invalid. The basis for ordering from HEIDENHAIN is always the catalog edition valid when the contract is made.

Standards (ISO, EN, etc.) apply only where explicitly stated in the catalog.

Content

Overview and Specifications					
	Selection Guide		4		
	Measuring Principles	Measuring standard, measuring methods, scanning methods	6		
	Accuracy		7		
	Mechanical Design Types and Mounting	Rotary encoders with integral bearing and stator coupling	8		
		Rotary encoders with integral bearing for separate shaft coupling	9		
		Shaft couplings	10		
	General Mechanical Information		12		
Specifications					
		Absolute Rotary Encoders	Incremental Rotary Encoders		
	Mounted Stator Coupling		ERN 1000 series	14	
			ECN 400/EQN 400 series	ERN 400 series	16
			ECN 400/EQN 400 series with universal stator coupling	ERN 400 series with universal stator coupling	20
			ECN 100 series	ERN 100 series	24
	Separate Shaft Coupling		ROD 1000 series	26	
			ROC 400/ROQ 400 series with synchro flange	ROD 400 series with synchro flange	28
			ROC 415, ROC 417 with synchro flange		32
			ROC 400/ROQ 400 series with clamping flange	ROD 400 series with clamping flange	34
Electrical Connection					
	Interfaces and Pin Layouts	Incremental signals	 1 V _{PP}	38	
				40	
				42	
			Absolute position values	EnDat	44
				PROFIBUS-DP	51
				SSI	54
			HEIDENHAIN Measuring Equipment and Counter Cards		56
			Connecting Elements and Cables		57
		General Electrical Information		60	
Sales and Service					
		Worldwide		62	
		Germany		64	

Selection Guide

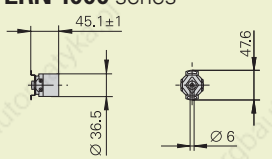
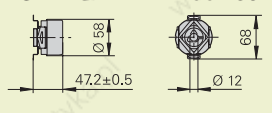
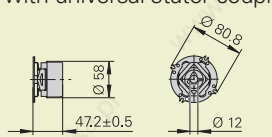
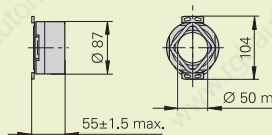
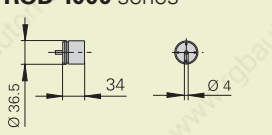
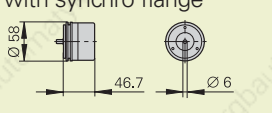
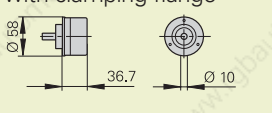
Rotary Encoders	Absolute Singleturn				Multiturn	
Interface	EnDat 2.2 / 02	EnDat 2.2/22	SSI	PROFIBUS-DP	EnDat 2.2 / 02	EnDat 2.2/22
Power supply	5 V	3.6 to 5.25 V	5 V or 10 to 30 V	10 to 30 V	5 V	3.6 to 5.25 V
With Built-in Stator Coupling						
ERN 1000 series 	–	–	–	–	–	–
ECN/EQN/ERN 400* series 	ECN 413 Positions/rev: 13 bits	ECN 425 Positions/rev: 25 bits	ECN 413 Positions/rev: 13 bits	–	EQN 425 Positions/rev: 13 bits 4096 revolutions	EQN 437 Positions/rev: 25 bits 4096 revolutions
ECN/EQN/ERN 400* series with universal stator coupling 	ECN 413 Positions/rev: 13 bits	ECN 425 Positions/rev: 25 bits	–	–	EQN 425 Positions/rev: 13 bits 4096 revolutions	EQN 437 Positions/rev: 25 bits 4096 revolutions
ECN/ERN 100 series 	ECN 113 Positions/rev: 13 bits	ECN 125 Positions/rev: 25 bits	ECN 113 Positions/rev: 13 bits	–	–	–
For Separate Shaft Coupling						
ROD 1000 series 	–	–	–	–	–	–
ROC/ROQ/ROD 400* series with synchro flange 	ROC 413 Positions/rev: 13 bits	ROC 425 Positions/rev: 25 bits	ROC 410 ROC 412 ROC 413 Positions/rev: 10/12/13 bits	ROC 413 Positions/rev: 13 bits	ROQ 425 Positions/rev: 13 bits 4096 revolutions	ROQ 437 Positions/rev: 25 bits 4096 revolutions
	ROC 415 ROC 417 Positions/rev: 15/17 bits			–		
ROC/ROQ/ROD 400* series with clamping flange 	ROC 413 Positions/rev: 13 bits	ROC 425 Positions/rev: 25 bits	ROC 413 Positions/rev: 13 bits	ROC 413 Positions/rev: 13 bits	ROQ 425 Positions/rev: 13 bits 4096 revolutions	ROQ 437 Positions/rev: 25 bits 4096 revolutions

*Versions with EEx protection on request

			Incremental				
SSI	PROFIBUS-DP						
5 V or 10 to 30 V	10 to 30 V	5 V	10 to 30 V	10 to 30 V	5 V		
–	–	ERN 1020 100 to 3600 lines	–	ERN 1030 60 to 3600 lines	ERN 1080 100 to 3600 lines	 14	
EQN 425 Positions/rev: 13 bits 4096 revolutions	–	ERN 420 250 to 5000 lines	ERN 460 250 to 5000 lines	ERN 430 250 to 5000 lines	ERN 480 1000 to 5000 lines	 16	
–	–	ERN 420 250 to 5000 lines	ERN 460 250 to 5000 lines	ERN 430 250 to 5000 lines	ERN 480 1000 to 5000 lines	 20	
–	–	ERN 120 1000 to 5000 lines	–	ERN 130 1000 to 5000 lines	ERN 180 1000 to 5000 lines	 24	
–	–	ROD 1020 100 to 3600 lines	–	ROD 1030 60 to 3600 lines	ROD 1080 100 to 3600 lines	 26	
ROQ 425 Positions/rev: 13 bits 4096 revolutions	ROQ 425 Positions/rev: 13 bits 4096 revolutions	ROD 426 50 to 10000 lines	ROD 466 50 to 10000 lines	ROD 436 50 to 5000 lines	ROD 486 1000 to 5000 lines	 28	
ROQ 425 Positions/rev: 13 bits 4096 revolutions	ROQ 425 Positions/rev: 13 bits 4096 revolutions	ROD 420 50 to 5000 lines	–	ROD 430 50 to 5000 lines	ROD 480 1000 to 5000 lines	 34	

Measuring Principles

Measuring Standard

Measuring Methods

HEIDENHAIN encoders with optical scanning incorporate measuring standards of periodic structures known as graduations. These graduations are applied to a carrier substrate of glass or steel.

These precision graduations are manufactured in various photolithographic processes. Graduations are fabricated from:

- extremely hard chromium lines on glass,
- matte-etched lines on gold-plated steel tape, or
- three-dimensional structures on glass or steel substrates.

The photolithographic manufacturing processes developed by HEIDENHAIN produce grating periods of typically 50 μm to 4 μm .

These processes permit very fine grating periods and are characterized by a high definition and homogeneity of the line edges. Together with the photoelectric scanning method, this high edge definition is a precondition for the high quality of the output signals.

The master graduations are manufactured by HEIDENHAIN on custom-built high-precision ruling machines.

With **absolute measuring methods**, the position value is available from the encoder immediately upon switch-on and can be called at any time by the subsequent electronics. There is no need to move the axes to find the reference position. The absolute position information is read **from the disk graduation**, which consists of several parallel graduation tracks.

The track with the finest grating period is interpolated for the position value and at the same time is used to generate an optional incremental signal.

In **singleturn encoders** the absolute position information repeats itself with every revolution. **Multiturn encoders** can also distinguish between revolutions.

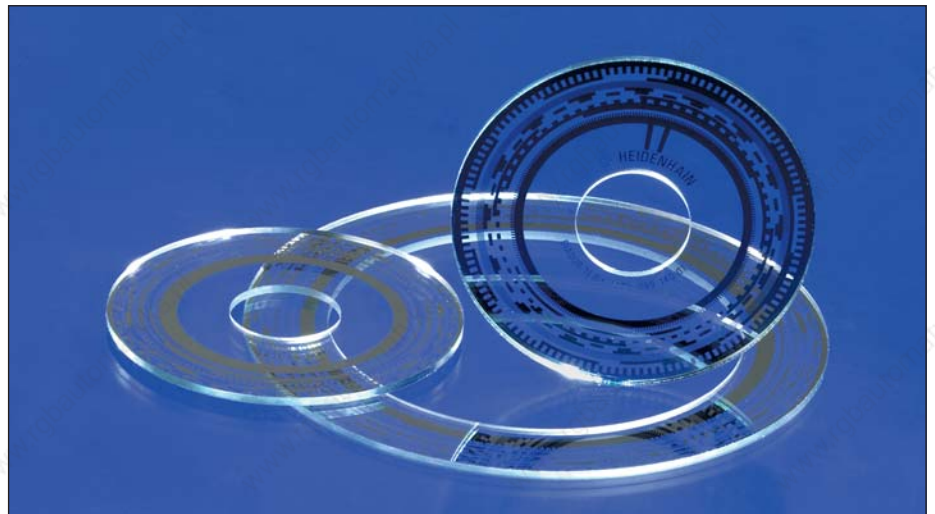

Circular graduations of absolute rotary encoders

With **incremental measuring methods**, the graduation consists of a periodic grating structure. The position information is obtained **by counting** the individual increments (measuring steps) from some point of origin. Since an absolute reference is required to ascertain positions, the graduated disks are provided with an additional track that bears a **reference mark**.

The absolute position established by the reference mark is gated with exactly one measuring step.

The reference mark must therefore be scanned to establish an absolute reference or to find the last selected datum.

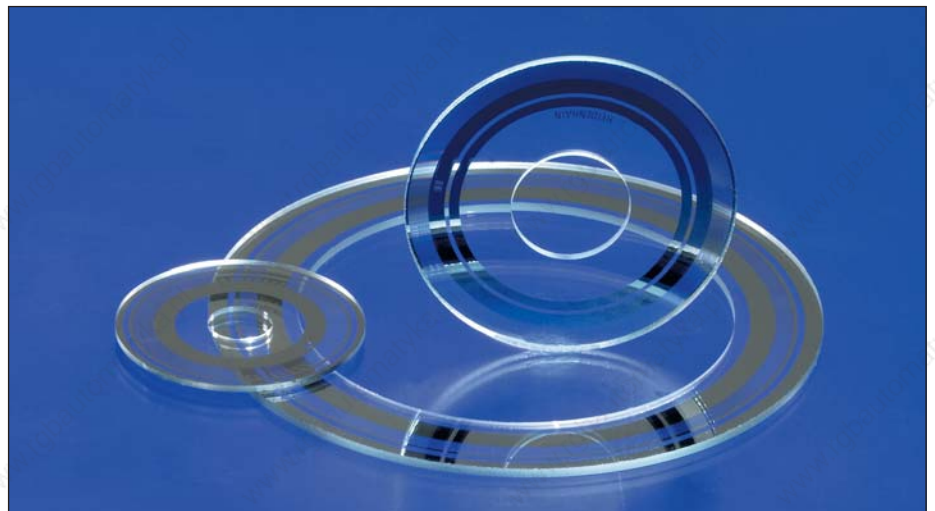

Circular graduations of incremental rotary encoders

Scanning Methods

Photoelectric Scanning

Most HEIDENHAIN encoders operate using the principle of photoelectric scanning. The photoelectric scanning of a measuring standard is contact-free, and therefore without wear. This method detects even very fine lines, no more than a few microns wide, and generates output signals with very small signal periods.

The ECN, EQN, ERN and ROC, ROQ, ROD rotary encoders use the imaging scanning principle.

Put simply, the imaging scanning principle functions by means of projected-light signal generation: two graduations with equal grating periods are moved relative to each other—the scale and the scanning reticle. The carrier material of the scanning reticle is transparent, whereas the graduation on the measuring standard may be applied to a transparent or reflective surface.

When parallel light passes through a grating, light and dark surfaces are projected at a certain distance. An index grating with the same grating period is located here. When the two gratings move relative to each other, the incident light is modulated. If the gaps in the gratings are aligned, light passes through. If the lines of one grating coincide with the gaps of the other, no light passes through. Photovoltaic cells convert these variations in light intensity into nearly sinusoidal electrical signals. Practical mounting tolerances for encoders with the imaging scanning principle are achieved with grating periods of 10 µm and larger.

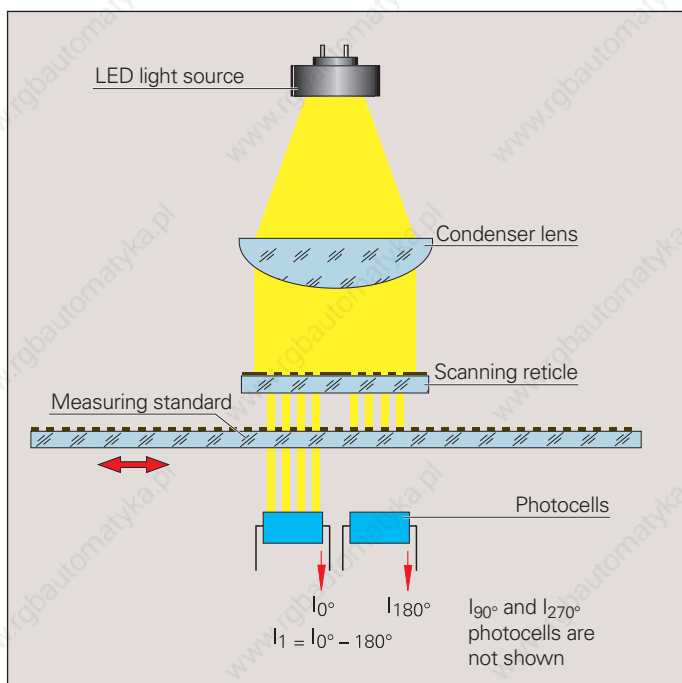

Photoelectric scanning according to the imaging scanning principle

The accuracy of position measurement with rotary encoders is mainly determined by:

- the directional deviation of the radial grating,
- the eccentricity of the graduated disk to the bearing,
- the radial deviation of the bearing,
- the error resulting from the connection with a shaft coupling (on rotary encoders with stator coupling this error lies within the system accuracy),
- the interpolation error during signal processing in the integrated or external interpolation and digitizing electronics.

For **incremental rotary encoders** with line counts up to 5000:

The maximum directional deviation at 20 °C ambient temperature and slow speed (scanning frequency between 1 kHz and 2 kHz) lies within

$$\pm \frac{18^\circ \text{ mech.} \cdot 3600}{\text{Line count } z} \text{ [angular seconds]}$$

which equals

$$\pm \frac{1}{20} \text{ grating period.}$$

ROD rotary encoders with 6000 to 10000 signal periods per revolution have a system accuracy of ± 12 angular seconds.

The accuracy of absolute position values from **absolute rotary encoders** is given in the specifications for each model.

For absolute rotary encoders with **complementary incremental signals**, the accuracy depends on the line count:

Line count	Accuracy
512	± 60 angular seconds
2048	± 20 angular seconds
8192	± 10 angular seconds

The above accuracy data refer to incremental measuring signals at an ambient temperature of 20 °C (68 °F) and at slow speed.

Mechanical Design Types and Mounting

Rotary Encoders with Integral Bearing and Stator Coupling

ECN/EQN/ERN rotary encoders have integrated bearings and a mounted stator coupling. They compensate radial runout and alignment errors without significantly reducing the accuracy. The encoder shaft is directly connected with the shaft to be measured. During angular acceleration of the shaft, the stator coupling must absorb only that torque caused by friction in the bearing. The stator coupling permits axial motion of the measured shaft:

ECN/EQN/ERN 400:	± 1 mm
ERN 1000:	± 0.5 mm
ECN/ERN 100:	± 1.5 mm

Mounting

The rotary encoder is slid by its hollow shaft onto the measured shaft, and the rotor is fastened by two screws or three eccentric clamps. For rotary encoders with hollow through shaft, the rotor can also be fastened at the end opposite to the flange. Rotary encoders of the ECN/EQN/ERN 1300 series are particularly well suited for repeated mounting (see the brochure titled *Position Encoders for Servo Drives*). The stator is connected without a centering collar on a flat surface. The **universal stator coupling** of the ECN/EQN/ERN 400 permits versatile mounting, e.g. by its thread provided for fastening it from outside to the motor cover. Dynamic applications require the highest possible natural frequencies f_N of the system (also see *General Mechanical Information*). This is attained by connecting the shafts on the flange side and fastening the coupling by four cap screws or, on the ERN 1000, with special washers (see *Mounting Accessories*).

Natural frequency f_N with coupling fastened by 4 screws

	Stator coupling	Cable	Flange socket	
			Axial	Radial
ECN/EQN/ERN 400	Standard	1550 Hz	1500 Hz	1000 Hz
	Universal	1400 Hz ¹⁾	1400 Hz	900 Hz
ECN/ERN 100		1000 Hz	–	400 Hz
ERN 1000		950 Hz ²⁾	–	–

¹⁾ Also when fastening with 2 screws

²⁾ Also when fastening with 2 screws and washers

If the encoder shaft is subject to high loads, for example from friction wheels, pulleys, or sprockets, HEIDENHAIN recommends mounting the ECN/EQN/ERN 400 with a bearing assembly (see *Mounting Accessories*).

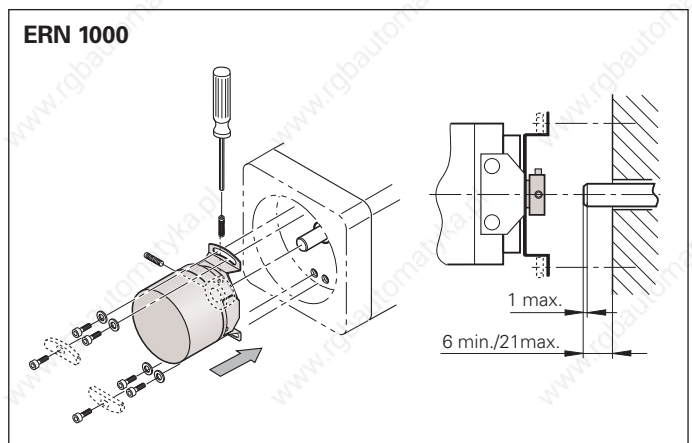
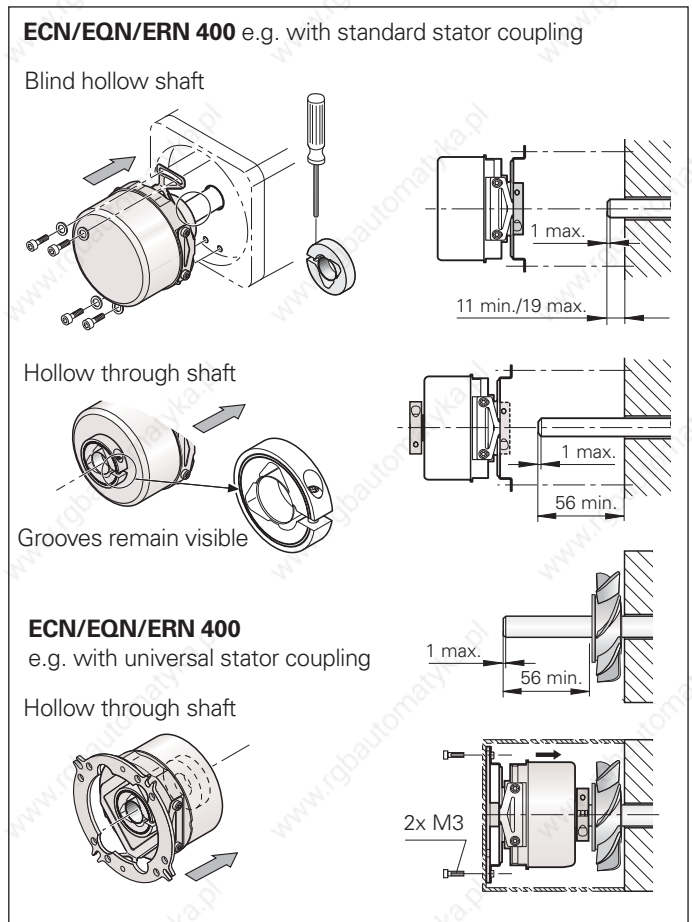
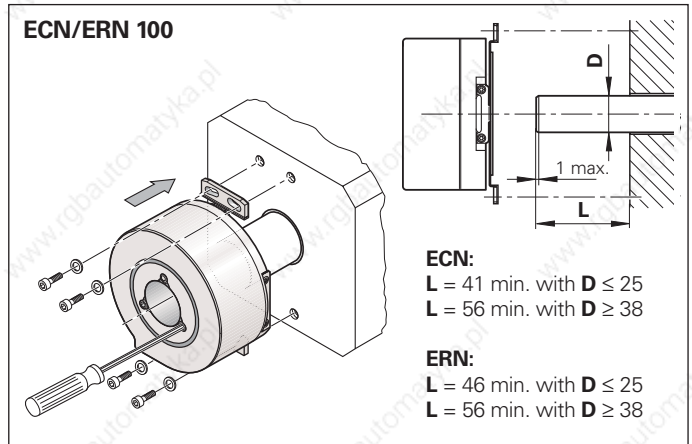

Rotary Encoders with Integral Bearing for Separate Shaft Coupling

ROC/ROQ/ROD rotary encoders have integrated bearings and a solid shaft. The encoder shaft is connected with the measured shaft through a separate rotor coupling. The coupling compensates axial motion and misalignment (radial and angular offset) between the encoder shaft and measured shaft. This relieves the encoder bearing of additional external loads that would otherwise shorten its service life. Diaphragm and metal bellows couplings designed to connect the rotor of the ROC/ROQ/ROD encoders are available (see *Shaft Couplings*).

ROC/ROQ/ROD 400 series rotary encoders permit high bearing loads (see diagram). They can therefore also be mounted directly onto mechanical transfer elements such as gears or friction wheels. If the encoder shaft is subject to relatively high loads, for example from friction wheels, pulleys, or sprockets, HEIDENHAIN recommends mounting the ECN/EQN/ERN 400 with a bearing assembly.

Mounting

Rotary encoders with synchro flange

- by the synchro flange with three fixing clamps (see *Mounting Accessories*), or
- by the fastening thread on the flange face and an adapter flange (for ROC/ROQ/ROD 400 see *Mounting Accessories*).

Rotary encoders with clamping flange

- by the fastening thread on the flange face and an adapter flange (see *Mounting Accessories*) or
- by clamping at the clamping flange.

The centering collar on the synchro flange or clamping flange serves to center the encoder.

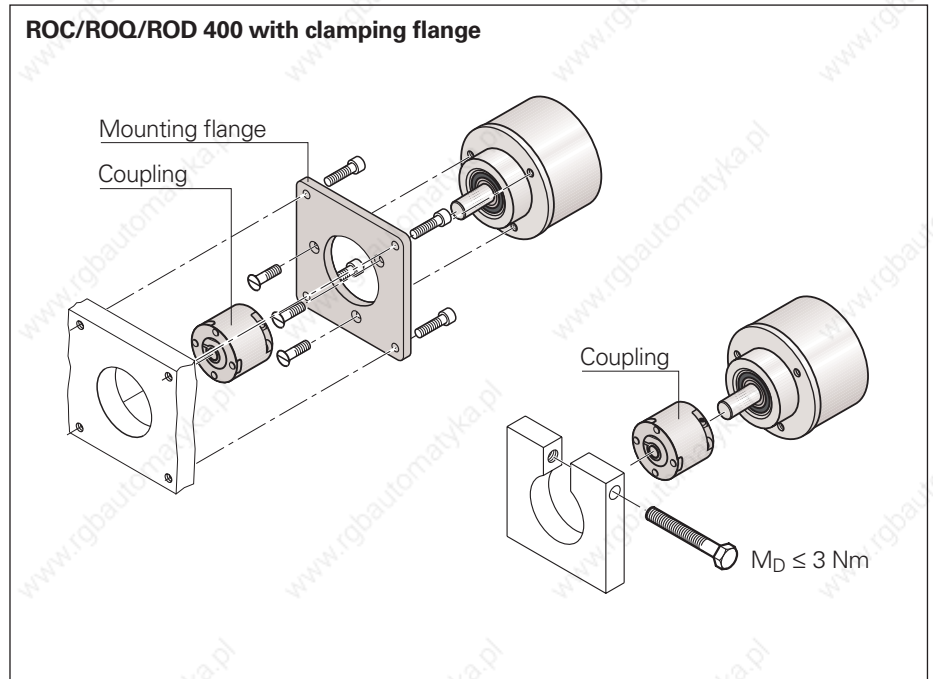
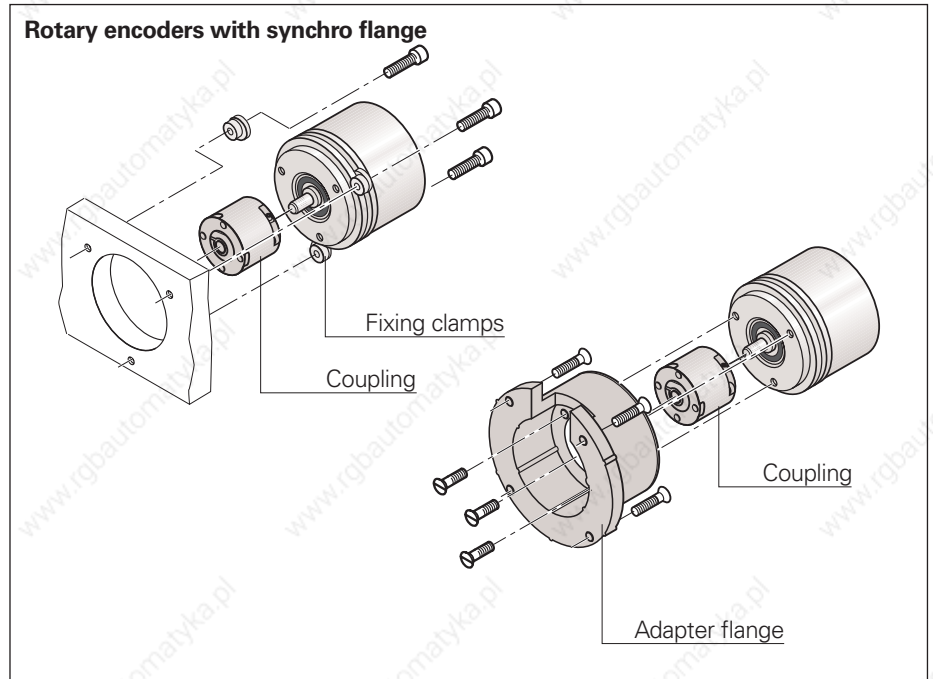

Bearing lifetime of ROC/ROQ/ROD 400

The lifetime of the shaft bearing depends on the shaft load, the shaft speed, and the point of force application. The values given in the specifications for the shaft load are valid for all permissible speeds, and do not limit the bearing lifetime. The diagram shows an example of the different bearing lifetimes to be expected with different loads. The different points of force application of shafts with 6 mm and 10 mm diameters have an effect on the bearing lifetime.

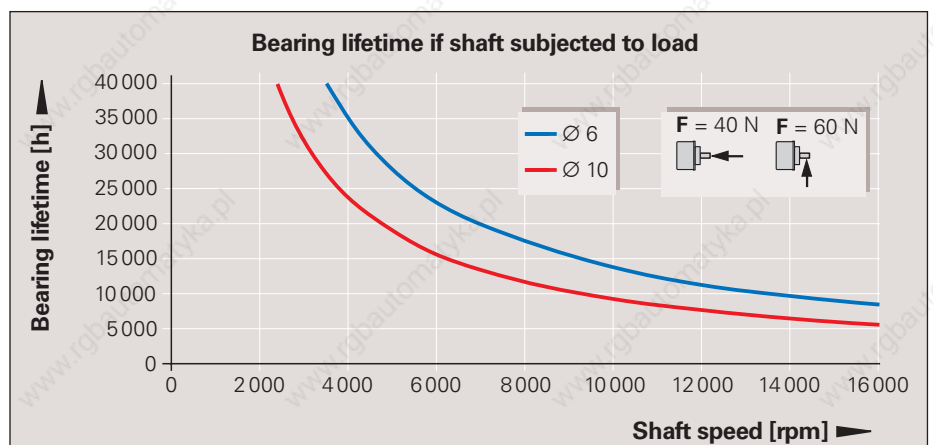

Shaft Couplings

	ROC/ROQ/ROD 400				ROD 1000	ROC 417, ROC 415	
	Diaphragm couplings with galvanic isolation				Metal bellows coupling	Diaphragm coupling	Flat coupling
	K 14	K 17/01 K 17/06	K 17/02 K 17/04	K 17/03	18EBN3	K 03	K 18
Hub bore	6 mm	6 mm 6/5 mm	6/10 mm 10 mm	10 mm	4/4 mm	10 mm	10 mm
Kinematic transfer error*	± 6"	± 10"			± 40"	± 2"	± 3"
Torsional rigidity	500 $\frac{\text{Nm}}{\text{rad}}$	150 $\frac{\text{Nm}}{\text{rad}}$	200 $\frac{\text{Nm}}{\text{rad}}$	300 $\frac{\text{Nm}}{\text{rad}}$	60 $\frac{\text{Nm}}{\text{rad}}$	1500 $\frac{\text{Nm}}{\text{rad}}$	1200 $\frac{\text{Nm}}{\text{rad}}$
Max. torque	0.2 Nm	0.1 Nm		0.2 Nm	0.1 Nm	0.2 Nm	0.5 Nm
Max. radial offset λ	≤ 0.2 mm	≤ 0.5 mm			≤ 0.2 mm	≤ 0.3 mm	
Max. angular error α	≤ 0.5°	≤ 1°			≤ 0.5°	≤ 0.5°	
Max. axial offset δ	≤ 0.3 mm	≤ 0.5 mm			≤ 0.3 mm	≤ 0.2 mm	
Moment of inertia (approx.)	$6 \cdot 10^{-6} \text{ kgm}^2$	$3 \cdot 10^{-6} \text{ kgm}^2$		$4 \cdot 10^{-6} \text{ kgm}^2$	$0.3 \cdot 10^{-6} \text{ kgm}^2$	$20 \cdot 10^{-6} \text{ kgm}^2$	$75 \cdot 10^{-6} \text{ kgm}^2$
Permissible speed	16000 rpm	16000 rpm			12000 rpm	10000 rpm	1000 rpm
Torque for locking screws (approx.)	1.2 Nm				0.8 Nm	1.2 Nm	
Weight	35 g	24 g	23 g	27.5 g	9 g	100 g	117 g

*With radial misalignment $\lambda = 0.1 \text{ mm}$, angular error $\alpha = 0.15 \text{ mm}$ over $100 \text{ mm} \triangleq 0.09^\circ$ to $50 \text{ }^\circ\text{C}$

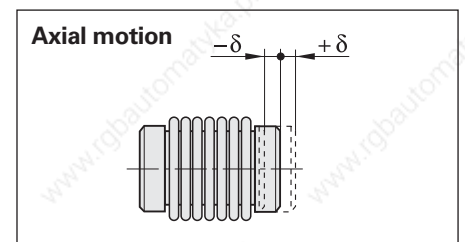
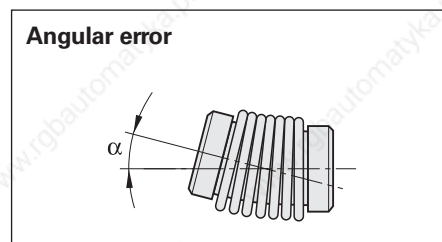
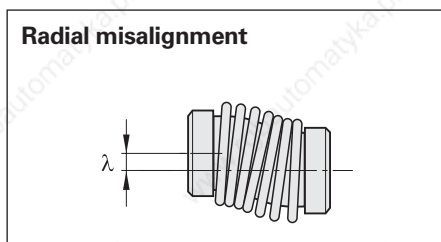

Mounting Accessories

Screwdriver bit
Screwdriver
See page 23



18 EBN 3 metal bellows coupling
for encoders of the ROD 1000 series
with **4 mm shaft diameter**
Id. Nr. 200393-02

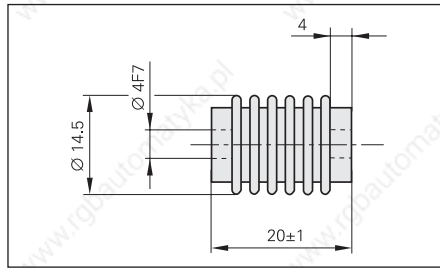

K14 diaphragm coupling
for ROC/ROQ/ROD 400 series
with **6 mm shaft diameter**
Id. Nr. 293328-01

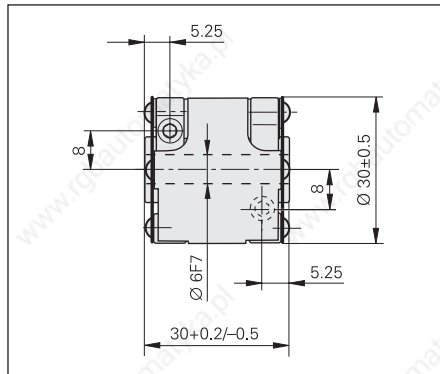

Recommended fit for the customer shaft: h6

K 17 diaphragm coupling
with galvanic isolation
for ROC/ROQ/ROD 400 series
with **6 or 10 mm shaft diameter**
Id. Nr. 296746-xx

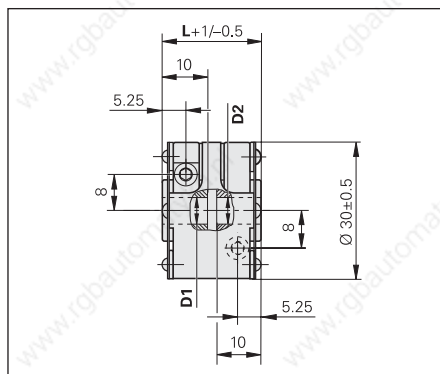

K 17 variants	D1	D2	L
01	$\varnothing 6 F7$	$\varnothing 6 F7$	22 mm
02	$\varnothing 6 F7$	$\varnothing 10 F7$	22 mm
03	$\varnothing 10 F7$	$\varnothing 10 F7$	30 mm
04	$\varnothing 10 F7$	$\varnothing 10 F7$	22 mm
06	$\varnothing 5 F7$	$\varnothing 6 F7$	22 mm

K 03 diaphragm coupling
Id. Nr. 200313-04
for
ROC 417
ROC 415

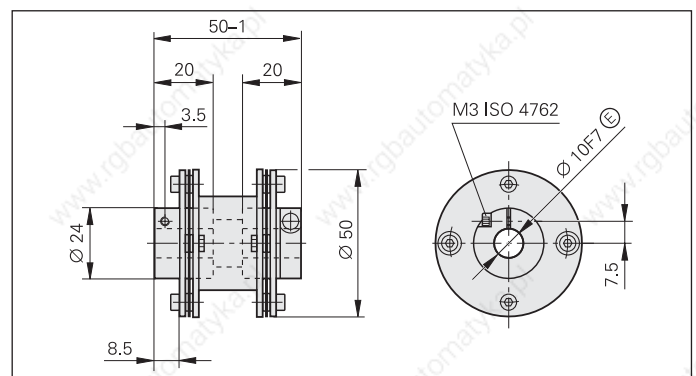

K 18 flat coupling
Id. Nr. 202227-01
for
ROC 417
ROC 415

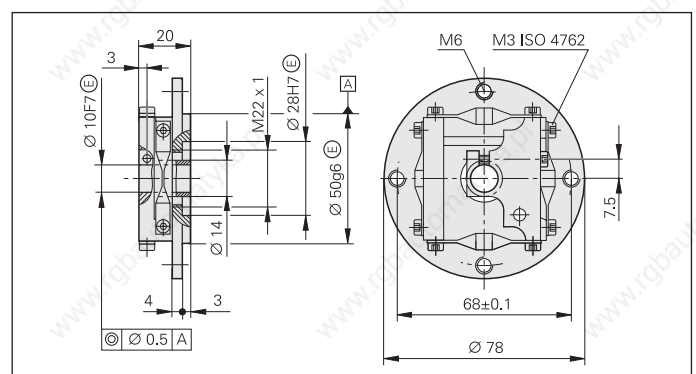

Dimensions in mm



Tolerancing ISO 8015
ISO 2768 - m H

▣ = Ball bearing

General Mechanical Information

UL certification

All rotary encoders and cables in this brochure comply with the UL safety regulations "cULus" for the USA and the "CSA" safety regulations for Canada. They are listed under file no. E205635.

Acceleration

Encoders are subject to various types of acceleration during operation and mounting.

- The indicated maximum values for **vibration** apply for frequencies of 55 Hz to 2000 Hz (**EN 60068-2-6**). Any acceleration exceeding permissible values, for example due to resonance depending on the application and mounting, might damage the encoder.

Comprehensive tests of the entire system are required.

- The maximum permissible acceleration values (semi-sinusoidal shock) for **shock and impact** are valid for 6 ms and 2 ms, respectively (**EN 60068-2-27**). Under no circumstances should a hammer or similar implement be used to adjust or position the encoder.
- The **permissible angular acceleration** for all encoders is over 10^5 rad/s^2 .

The maximum values for vibration and shock indicate the limits up to which the encoder can be operated without failure. For an encoder to realize its highest potential accuracy, the environmental and operating conditions described under *Measuring Accuracy* must be ensured. If the application includes increased shock and vibration loads, please ask for comprehensive assistance from HEIDENHAIN.

Natural frequencies

The rotor and the couplings of ROC/ROQ/ROD rotary encoders, as also the stator and stator coupling of ECN/EQN/ERN rotary encoders, form a single vibrating spring-mass system.

The **natural frequency** f_N should be as high as possible. A prerequisite for the highest possible natural frequency on **ROC/ROQ/ROD rotary encoders** is the use of a diaphragm coupling with a high torsional rigidity C (see *Shaft Couplings*).

$$f_N = \frac{1}{2 \cdot \pi} \cdot \sqrt{\frac{C}{I}}$$

f_N : Natural frequency in Hz

C : Torsional rigidity of the coupling in Nm/rad

I : Moment of inertia of the rotor in kgm^2

ECN/EQN/ERN rotary encoders with their stator couplings form a vibrating spring-mass system whose **natural frequency** f_N should be as high as possible. If radial and/or axial acceleration forces are added, the stiffness of the encoder bearings and the encoder stators are also significant. If such loads occur in your application, HEIDENHAIN recommends consulting with the main facility in Traunreut.

Protection against contact (EN 60529)

After encoder installation, all rotating parts must be protected against accidental contact during operation.

Protection (EN 60529)

Unless otherwise indicated, all rotary encoders meet protection standard IP 64 (ExN/ROx 400: IP 67) according to EN 60529.

This includes housings, cable outlets and flange sockets when the connector is fastened. The **shaft inlet** provides protection to IP 64 or IP 65. Splash water should not contain any substances that would have harmful effects on the encoder parts. If the standard protection of the shaft inlet is not sufficient (such as when the encoders are mounted vertically), additional labyrinth seals should be provided.

Many encoders are also available with protection to class IP 66 for the shaft inlet. The sealing rings used to seal the shaft are subject to wear due to friction, the amount of which depends on the specific application.

Expendable parts

HEIDENHAIN encoders contain components that are subject to wear, depending on the application and manipulation. These include in particular the following parts:

- LED light source
- Bearings in encoders with integral bearing
- Shaft sealing rings for rotary and angular encoders
- Cables subject to frequent flexing

System tests

Encoders from HEIDENHAIN are usually integrated as components in larger systems. Such applications require **comprehensive tests of the entire system** regardless of the specifications of the encoder.

The specifications given in the brochure apply to the specific encoder, not to the complete system. Any operation of the encoder outside of the specified range or for any other than the intended applications is at the user's own risk.

In safety-oriented systems, the higher-level system must verify the position value of the encoder after switch-on.

Mounting

Work steps to be performed and dimensions to be maintained during mounting are specified solely in the mounting instructions supplied with the unit. All data in this catalog regarding mounting are therefore provisional and not binding; they do not become terms of a contract.

Temperature ranges

For the unit in its packaging, the **storage temperature range** is -30 to 80 °C (-22 to 176 °F). The **operating temperature range** indicates the temperatures that the encoder may reach during operation in the actual installation environment. The function of the encoder is guaranteed within this range (DIN 32878). The operating temperature is measured on the face of the encoder flange (see dimension drawing) and must not be confused with the ambient temperature.

The temperature of the encoder is influenced by:

- Mounting conditions
- The ambient temperature
- Self-heating of the encoder

The self-heating of an encoder depends both on its design characteristics (stator coupling/solid shaft, shaft sealing ring, etc.) and on the operating parameters (rotational speed, power supply). Higher heat generation in the encoder means that a lower ambient temperature is required to keep the encoder within its permissible operating temperature range.

These tables show the approximate values of self-heating to be expected in the encoders. In the worst case, a combination of operating parameters can exacerbate self-heating, for example a 30 V power supply and maximum rotational speed. Therefore, the actual operating temperature should be measured directly at the encoder if the encoder is operated near the limits of permissible parameters. Then suitable measures should be taken (fan, heat sinks, etc.) to reduce the ambient temperature far enough so that the maximum permissible operating temperature will not be exceeded during continuous operation. For high speeds at maximum permissible ambient temperature, special versions are available on request with reduced degree of protection (without shaft seal and its concomitant frictional heat).

Self-heating at supply voltage	15 V	30 V
ERN/ROD	Approx. + 5 K	Approx. + 10 K
ECN/EQN/ROC/ROQ	Approx. + 5 K	Approx. + 10 K

Typical self-heating of the encoder at supply voltages of 10 to 30 V. In 5 V versions, self-heating is negligible.

Heat generation at speed n_{max}		
Solid shaft	ROC/ROQ/ROD	Approx. + 5 K with protection class IP 64 Approx. + 10 K with protection class IP 66
Blind hollow shaft	ECN/EQN/ERN 400	Approx. + 30 K with protection class IP 64 Approx. + 40 K with protection class IP 66
	ERN 1000	Approx. + 10 K
Hollow through shaft	ECN/ERN 100 ECN/EQN/ERN 400	Approx. + 40 K with protection class IP 64 Approx. + 50 K with protection class IP 66

An encoder's typical self-heating values depend on its design characteristics at maximum permissible speed. The correlation between rotational speed and heat generation is nearly linear.

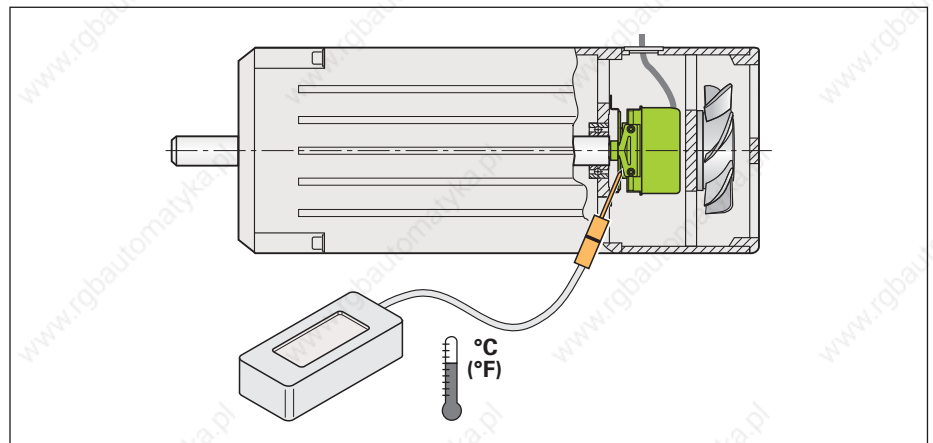

Measuring the actual operating temperature directly at the encoder

ERN 1000 Series

- Rotary encoders with mounted stator coupling
- Compact dimensions
- Blind hollow shaft $\varnothing 6$ mm

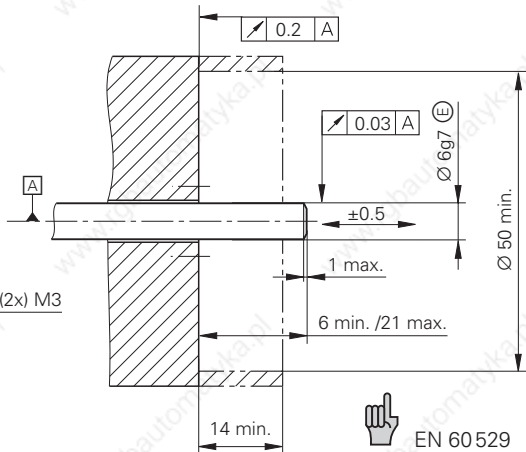
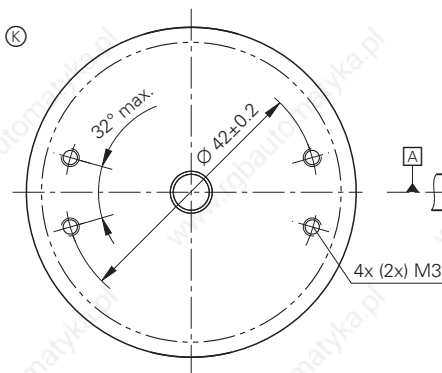
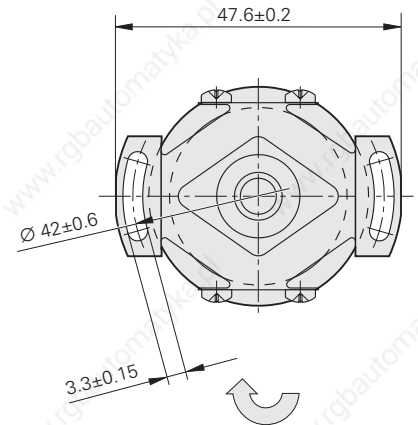
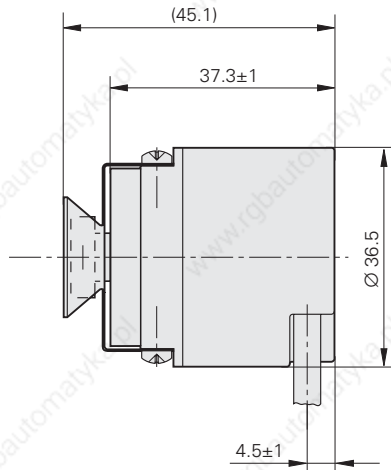
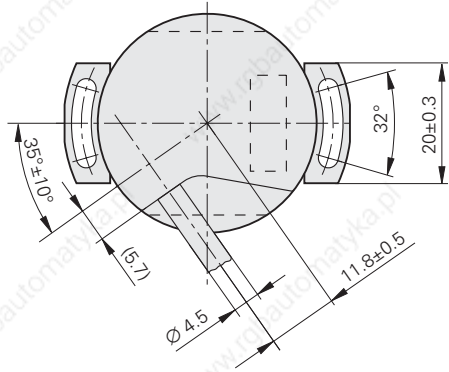
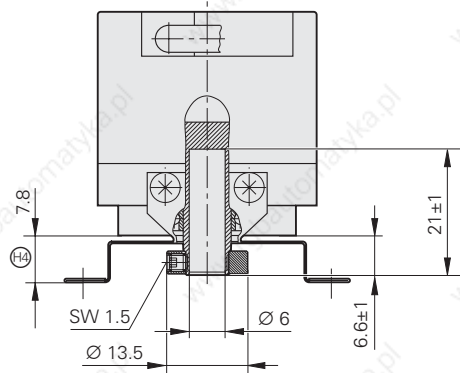

EN 60 529

Dimensions in mm

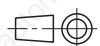

Tolerancing ISO 8015
ISO 2768 - m H

Cable radial, also usable axially

= Ball bearing

= Required mating dimensions

= Variable depending on the coupling

Direction of shaft rotation for output signals is described in interface description.

	Incremental		
	ERN 1020	ERN 1030	ERN 1080
Incremental signals	□ TTL	□ HTL	~ 1 V _{PP} ¹⁾
Line counts*	100 200 250 360 400 1000 1024 1250 1500 2000	500 720 900 2048 2500	3600
Cutoff freq. -3 dB	-	-	≥ 180 kHz
Scanning frequency	≤ 300 kHz	≤ 160 kHz	-
Edge separation a	≥ 0.43 μs	≥ 0.78 μs	-
Power supply	5 V ± 10%	10 to 30 V	5 V ± 10%
Current consumption without load	≤ 150 mA	≤ 150 mA	≤ 150 mA
Electrical connection*	Cable 1 m/5 m, with or without coupling M23		
Max. cable length	100 m		150 m
Shaft	Blind hollow shaft D = 6 mm		
Mechanically permissible speed	10000 rpm		
Starting torque	≤ 0.001 Nm (at 20 °C)		
Moment of inertia of rotor	0.5 · 10 ⁻⁶ kgm ²		
Permissible axial motion of measured shaft	± 0.5 mm		
Vibration 55 to 2000 Hz	≤ 100 m/s ² (IEC 60068-2-6)		
Shock 6 ms	≤ 1000 m/s ² (IEC 60068-2-27)		
Max. operating temperature ²⁾	100 °C	70 °C	100 °C
Min. operating temperature	<i>Fixed cable:</i> -40 °C <i>Moving cable:</i> -10 °C		
Protection ²⁾ EN 60529	IP 64		
Weight	Approx. 0.1 kg		

Bold: These preferred versions are available on short notice

* Please indicate when ordering

¹⁾ Restricted tolerances: Signal amplitude 0.8 to 1.2 V_{PP}

Mounting Accessories for ERN 1000 series

Washer

For increasing the natural frequency f_N and mounting with only two screws.

Id. Nr. 334653-01

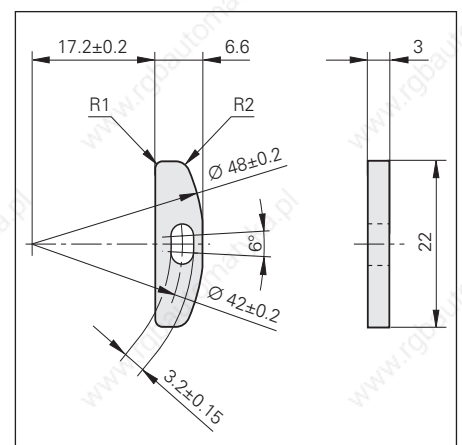

ECN/EQN/ERN 400 Series

- Rotary encoders with mounted stator coupling
- Blind hollow shaft or Hollow through shaft



Blind hollow shaft

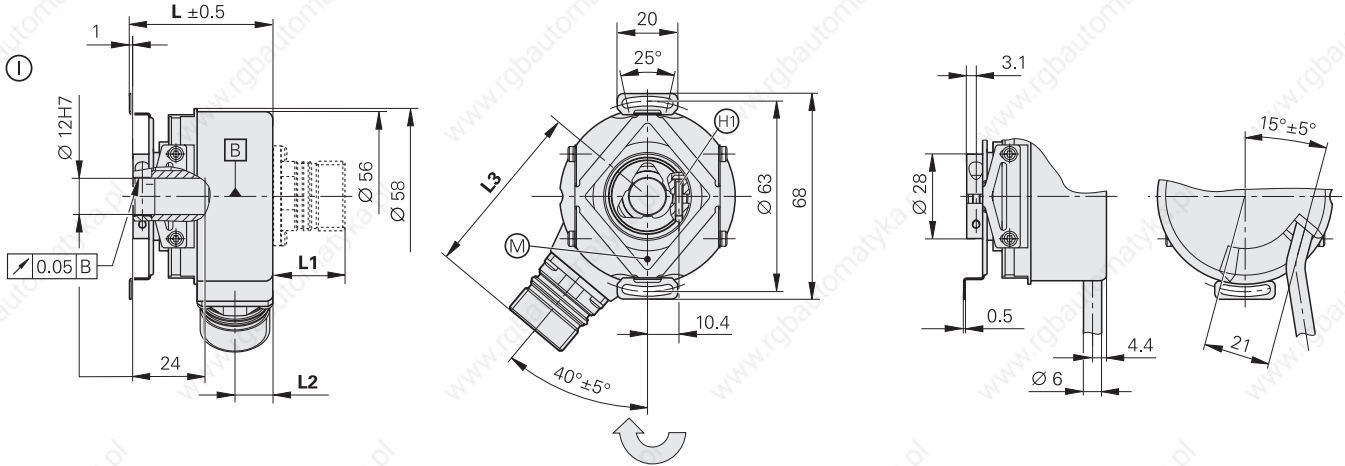

Hollow through shaft

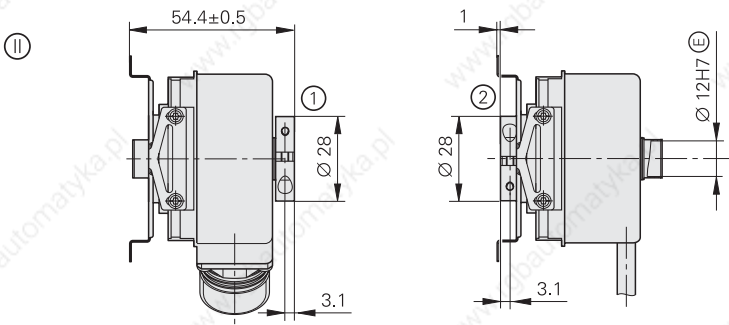

	L
ERN ECN/EQN 512 lines	47.2
ECN/EQN 2048 lines ECN 425/EQN 413	47.7

	Flange socket	
	M12	M23
L1	14	23.6
L2	12.5	12.5
L3	48.5	58.1

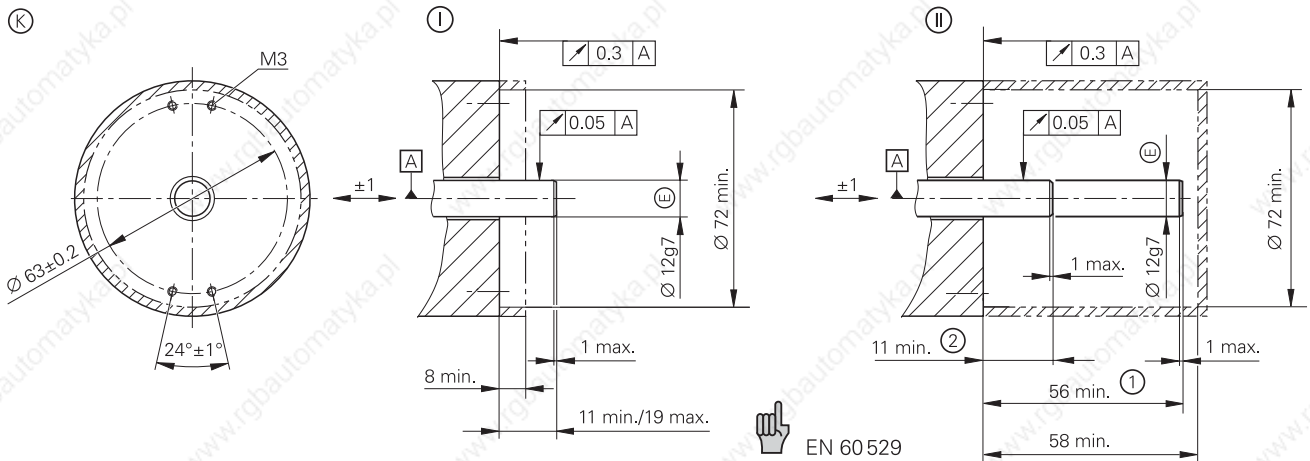

Dimensions in mm



Tolerancing ISO 8015
ISO 2768 - m H

Cable radial, also usable axially

⊠ = Ball bearing

⊞ = Bearing of encoder

Ⓜ = Measuring point for operating temperature

Ⓚ = Required mating dimensions



Ⓛ = Clamping screw M2.5 with hexalobular socket X8

Ⓢ = Hole circle for fastening, see coupling

① = Clamping ring on housing side (status at delivery)

② = Clamping ring on coupling side (optionally mountable)

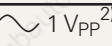
↻ Direction of shaft rotation for output signals is described in interface description.

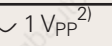
	Absolute						Incremental			
	Singletum			Multitum			ERN 420		ERN 460	ERN 430
	ECN 425 ¹⁾	ECN 413 ¹⁾	ECN 413 ¹⁾	EQN 437 ¹⁾	EQN 425 ¹⁾	EQN 425 ¹⁾				
Absolute position values*	EnDat 2.2	EnDat 2.2	SSI	EnDat 2.2	EnDat 2.2	SSI	-			
Ordering information	EnDat 22	EnDat 02		EnDat 22	EnDat 02					
Positions per rev.	33554432 (25 bits)	8192 (13 bits)		33554432 (25 bits)	8192 (13 bits)					
Revolutions	-			4096			-			
Code	Pure binary		Gray	Pure binary		Gray	-			
Elec. permissible speed/at accuracy	≤ 12000 rpm for continuous position values	512 lines: ≤ 5000 rpm/± 1 LSB 2048 lines: ≤ 1500 rpm/± 1 LSB ≤ 12000 rpm/± 50 LSB		≤ 12000 rpm for continuous position values	512 lines: ≤ 5000 rpm/± 1 LSB 2048 lines: ≤ 1500 rpm/± 1 LSB ≤ 12000 rpm/± 50 LSB		-			
Calculation time t_{cal}	≤ 5 μs	≤ 0.25 μs	≤ 0.5 μs	≤ 5 μs	≤ 0.25 μs	≤ 0.5 μs	-			
Incremental signals	None	 1 V _{PP} ²⁾		None	 1 V _{PP} ²⁾		 TTL	 HTL	 1 V _{PP} ²⁾	
Line counts*	-	512 2048	512	-	512 2048	512	250 ⁵⁾ 500 ⁵⁾ 1000 1024 1250 2000 2048 2500 3600 4096 5000			
Cutoff freq. -3 dB	-	512 lines: ≥ 100 kHz; 2048 lines: ≥ 200 kHz		-	512 lines: ≥ 100 kHz; 2048 lines: ≥ 200 kHz		-			≥ 180 kHz
Scanning frequency	-	-		-	-		≤ 300 kHz			-
Edge separation a	-	-		-	-		≥ 0.43 μs			-
System accuracy	± 20"	512 lines: ± 60"; 2048 lines: ± 20"		± 20"	512 lines: ± 60"; 2048 lines: ± 20"		1/20 of grating period			
Power supply*	3.6 to 5.25 V	5V ± 5 %	5V ± 5 % or 10 to 30 V	3.6 to 5.25 V	5V ± 5 %	5V ± 5 % or 10 to 30 V	5V ± 10 %	10 to 30 V	10 to 30 V	5V ± 10 %
Current consumption without load	≤ 150 mA	≤ 160 mA	≤ 160 mA	≤ 180 mA	≤ 200 mA	≤ 200 mA	120 mA	100 mA	150 mA	120 mA
Electrical connection*	<ul style="list-style-type: none"> Flange socket M12, radial Cable 1 m, with coupling M12 	<ul style="list-style-type: none"> Flange socket M23, radial Cable 1 m, with coupling M23 or without connecting element 		<ul style="list-style-type: none"> Flange socket M12, radial Cable 1 m, with coupling M12 	<ul style="list-style-type: none"> Flange socket M23, radial Cable 1 m, with coupling M23 or without connecting element 		<ul style="list-style-type: none"> Flange socket M23, radial and axial (with blind hollow shaft) Cable 1 m, without connecting element 			
Shaft*	Blind hollow shaft or hollow through shaft D = 12 mm						Blind hollow shaft or hollow through shaft D = 12 mm			
Mech. perm. speed n³⁾	≤ 6000 rpm/≤ 12000 rpm ⁶⁾						≤ 6000 rpm/≤ 12000 rpm ⁶⁾			
Starting torque at 20 °C below 20 °C	Blind hollow shaft: ≤ 0.01 Nm Hollow through shaft: ≤ 0.025 Nm ≤ 1 Nm						Blind hollow shaft: ≤ 0.01 Nm Hollow through shaft: ≤ 0.025 Nm ≤ 1 Nm			
Moment of inertia of rotor	4.3 · 10 ⁻⁶ kgm ²						4.3 · 10 ⁻⁶ kgm ²			
Permissible axial motion of measured shaft	± 1 mm						± 1 mm			
Vibration 55 to 2000 Hz Shock 6 ms/2 ms	≤ 300 m/s ² ⁴⁾ (EN 60068-2-6) ≤ 1000 m/s ² /≤ 2000 m/s ² (EN 60068-2-27)						≤ 300 m/s ² ⁴⁾ (EN 60068-2-6) ≤ 1000 m/s ² /≤ 2000 m/s ² (EN 60068-2-27)			
Max. operating temperature³⁾	$U_P = 5V$: 100 °C $U_P = 10$ to 30 V: 85 °C						100 °C	70 °C	100 °C	
Min. operating temperature	Flange socket or fixed cable: -40 °C Moving cable: -10 °C						Flange socket or fixed cable: -40 °C Moving cable: -10 °C			
Protection EN 60529	IP 67 at housing; IP 64 at shaft inlet						IP 67 at housing (IP 66 with hollow through shaft); IP 64 at shaft inlet			
Weight	Approx. 0.3 kg						Approx. 0.3 kg			

Bold: These preferred versions are available on short notice

* Please indicate when ordering

¹⁾ Available in 3rd quarter of 2005; for the previous version, see the *Rotary Encoders, January 2004* brochure

²⁾ Restricted tolerances: Signal amplitude 0.8 to 1.2 V_{PP}

³⁾ For the correlation between the operating temperature and the shaft speed or power supply, see *General Mechanical Information*

⁴⁾ 150 m/s² with flange socket version

⁵⁾ Not with ERN 480

⁶⁾ With two shaft clamps (only for hollow through shaft)

Mounting Accessories

for ERN/ECN/EQN 400 series

Shaft clamp ring
Screwdriver
Screwdriver bit
See page 23

Bearing assembly
for ERN/ECN/EQN 400 series
with blind hollow shaft
Id. Nr. 324320-01



The bearing assembly is capable of absorbing large radial shaft loads. It is therefore particularly recommended for use in applications with friction wheels, pulleys, or sprockets. It prevents overload of the encoder bearing. On the encoder side, the bearing assembly has a stub shaft with 12-mm diameter and is well suited for the ERN/ECN/EQN 400 encoders with blind hollow shaft. Also, the threaded holes for fastening the stator coupling are already provided. The flange of the bearing assembly has the same dimensions as the clamping flange of the ROD 420/430 series.

The bearing assembly can be fastened through the threaded holes on its face or with the aid of the mounting flange or the mounting bracket.

Mounting bracket
for bearing assembly
Id. Nr. 324322-01

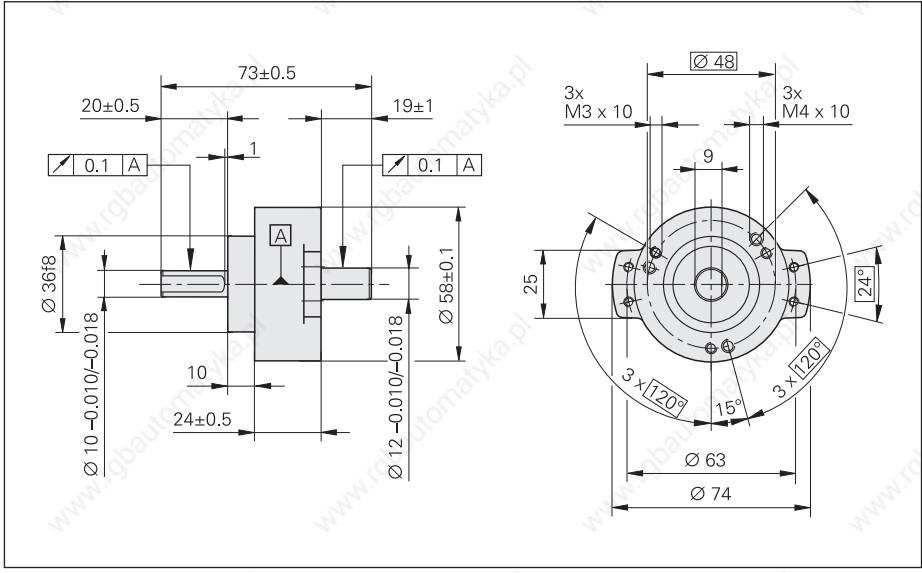

	Bearing assembly
Permissible speed n	Max. 6000 rpm
Shaft load	200 N axial and radial
Operating temperature	-40 to 100 °C

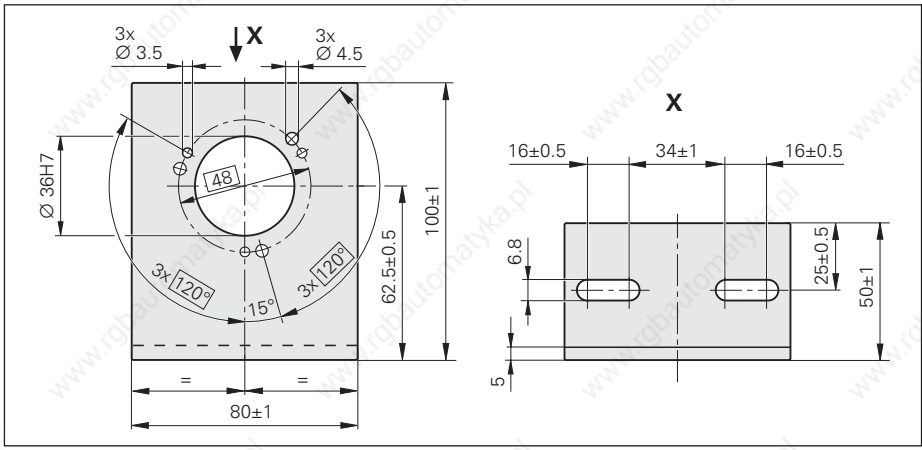
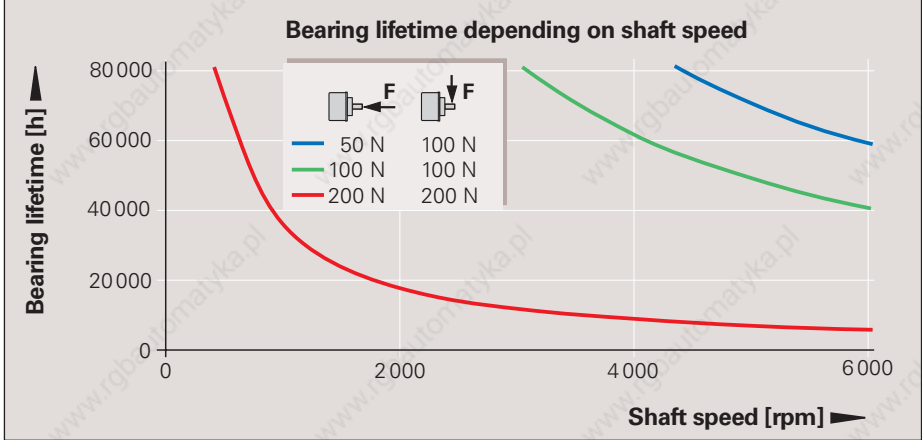

ECN/EQN/ERN 400 Series

- Rotary encoders with mounted universal stator coupling
- Blind hollow shaft or Hollow through shaft



Blind hollow shaft

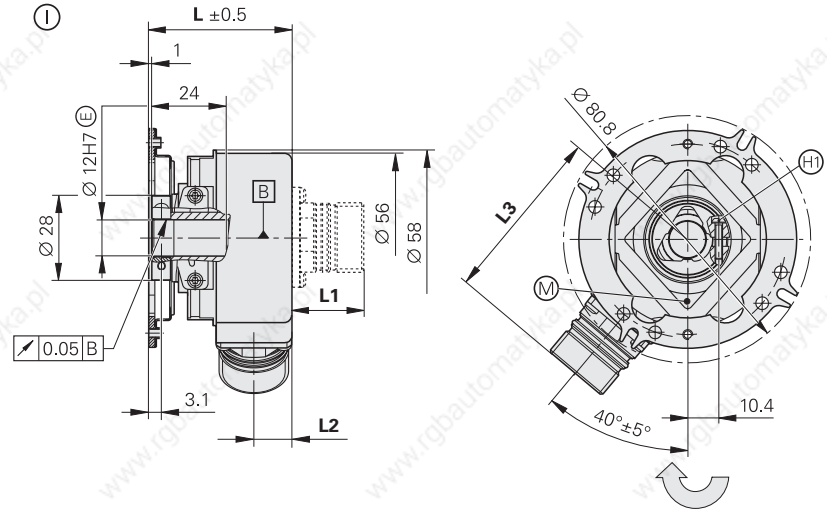

Hollow through shaft

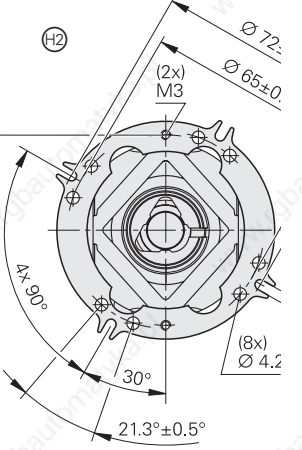
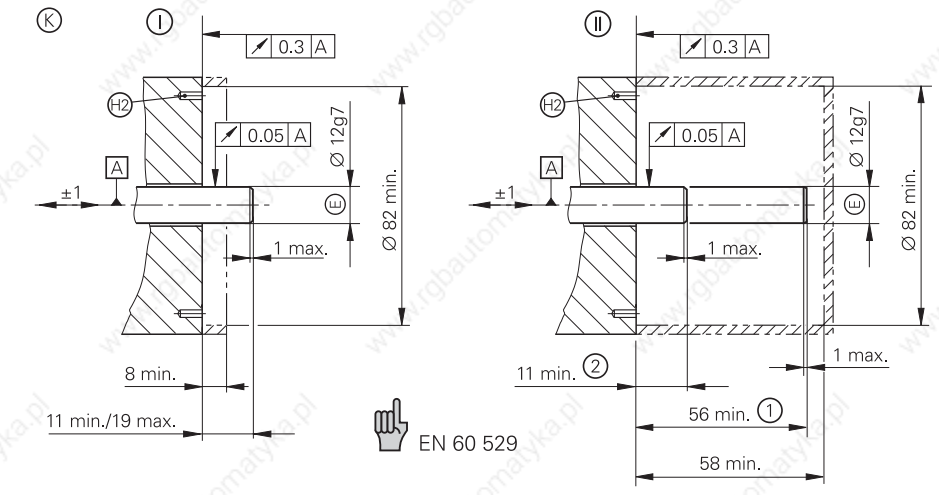
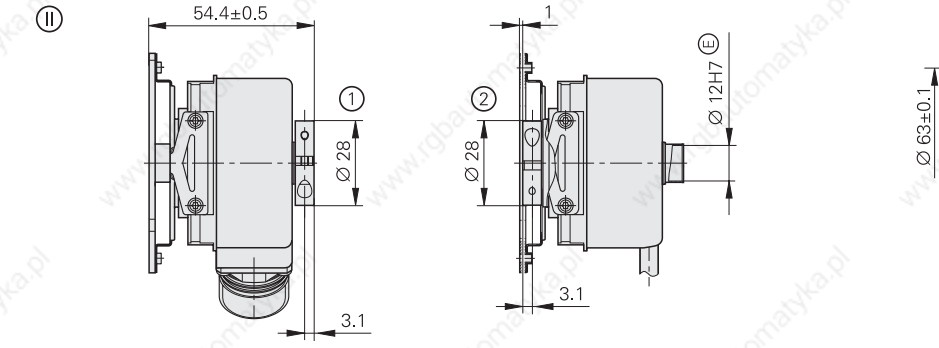

	L
ERN ECN/EQN 512 lines	47.2
ECN/EQN 2048 lines ECN 425/EQN 437	47.7





	Flange socket	
	M12	M23
L1	14	23.6
L2	12.5	12.5
L3	48.5	58.1

Dimensions in mm

Tolerancing ISO 8015
ISO 2768 - m H

Cable radial, also usable axially

- Ⓐ = Ball bearing
- Ⓑ = Bearing of encoder
- Ⓜ = Measuring point for operating temperature
- Ⓚ = Required mating dimensions
- Ⓜ = Clamping screw M2.5 with hexalobular socket X8
- Ⓢ = Hole circle for fastening, see coupling
- ① = Clamping ring on housing side (status at delivery)
- ② = Clamping ring on coupling side (optionally mountable)
- ↻ Direction of shaft rotation for output signals is described in interface description.

	Absolute						Incremental			
	Singletum			Multitum			ERN 420	ERN 460	ERN 430	ERN 480
	ECN 425 ¹⁾	ECN 413 ¹⁾	ECN 413 ¹⁾	EQN 437 ¹⁾	EQN 425 ¹⁾	EQN 425 ¹⁾				
Absolute position values*	EnDat 2.2	EnDat 2.2	SSI	EnDat 2.2	EnDat 2.2	SSI	-			
Ordering information	EnDat 22	EnDat 02		EnDat 22	EnDat 02					
Positions per rev.	33554432 (25 bits)	8192 (13 bits)		33554432 (25 bits)	8192 (13 bits)		-			
Revolutions	-			4096			-			
Code	Pure binary		Gray	Pure binary		Gray	-			
Elec. permissible speed/at accuracy	≤ 12000 rpm for continuous position values	512 lines: ≤ 5000 rpm/± 1 LSB 2048 lines: ≤ 12000 rpm/± 100 LSB ≤ 1500 rpm/± 1 LSB ≤ 12000 rpm/± 50 LSB		≤ 12000 rpm for continuous position values	512 lines: ≤ 5000 rpm/± 1 LSB 2048 lines: ≤ 10000 rpm/± 100 LSB ≤ 1500 rpm/± 1 LSB ≤ 10000 rpm/± 50 LSB		-			
Calculation time t_{cal}	≤ 5 μs	≤ 0.25 μs	≤ 0.5 μs	≤ 5 μs	≤ 0.5 μs	≤ 0.5 μs	-			
Incremental signals	None	 1 V _{PP} ²⁾		None	 1 V _{PP} ²⁾		 TTL		 HTL	 1 V _{PP} ²⁾
Line counts*	-	512 2048	512	-	512 2048	512	250 ⁵⁾ 500 ⁵⁾ 1000 1024 1250 2000 2048 2500 3600 4096 5000			
Cutoff freq. -3 dB	-	512 lines: ≥ 100 kHz; 2048 lines: ≥ 200 kHz		-	512 lines: ≥ 100 kHz; 2048 lines: ≥ 200 kHz		-			
Scanning frequency	-	-		-	-		≤ 300 kHz			
Edge separation a	-	-		-	-		≥ 0.43 μs			
System accuracy	± 20"	512 lines: ± 60"; 2048 lines: ± 20"		± 60"	512 lines: ± 60"; 2048 lines: ± 20"		1/20 of grating period			
Power supply*	3.6 to 5.25 V	5 V ± 5 %	5 V ± 5 % or 10 to 30 V	3.6 to 5.25 V	5 V ± 5 %	5 V ± 5 % or 10 to 30 V	5 V ± 10 %	10 to 30 V	10 to 30 V	5 V ± 10 %
Current consumption without load	≤ 150 mA	≤ 160 mA	≤ 160 mA	≤ 180 mA	≤ 200 mA	≤ 200 mA	120 mA	100 mA	150 mA	120 mA
Electrical connection*	<ul style="list-style-type: none"> Flange socket M12, radial Cable 1 m, with coupling M12 	<ul style="list-style-type: none"> Flange socket M23, radial Cable 1 m, with coupling M23 or without connecting element 		<ul style="list-style-type: none"> Flange socket M12, radial Cable 1 m, with coupling M12 	<ul style="list-style-type: none"> Flange socket M23, radial Cable 1 m, with coupling M23 or without connecting element 		<ul style="list-style-type: none"> Flange socket M23, radial and axial (with blind hollow shaft) Cable 1 m, without connecting element 			
Shaft*	Blind hollow shaft or hollow through shaft D = 12 mm						Blind hollow shaft or hollow through shaft D = 12 mm			
Mech. perm. speed n³⁾	≤ 6000 rpm/≤ 12000 rpm ⁶⁾						≤ 6000 rpm/≤ 12000 rpm ⁶⁾			
Starting torque at 20 °C below 20 °C	Blind hollow shaft: ≤ 0.01 Nm Hollow through shaft: ≤ 0.025 Nm ≤ 1 Nm						Blind hollow shaft: ≤ 0.01 Nm Hollow through shaft: ≤ 0.025 Nm ≤ 1 Nm			
Moment of inertia of rotor	4.3 · 10 ⁻⁶ kgm ²						4.3 · 10 ⁻⁶ kgm ²			
Permissible axial motion of measured shaft	± 1 mm						± 1 mm			
Vibration 55 to 2000 Hz Shock 6 ms/2 ms	≤ 300 m/s ² ⁴⁾ (EN 60068-2-6) ≤ 1000 m/s ² /≤ 2000 m/s ² (EN 60068-2-27)						≤ 300 m/s ² ⁴⁾ (EN 60068-2-6) ≤ 1000 m/s ² /≤ 2000 m/s ² (EN 60068-2-27)			
Max. operating temperature³⁾	$U_P = 5 V$: 100 °C $U_P = 10$ to 30 V: 85 °C						100 °C	70 °C	100 °C	
Min. operating temperature	Flange socket or fixed cable: -40 °C Moving cable: -10 °C						Flange socket or fixed cable: -40 °C Moving cable: -10 °C			
Protection EN 60529	IP 67 at housing; IP 64 at shaft inlet						IP 67 at housing (IP 66 with hollow through shaft); IP 64 at shaft inlet			
Weight	Approx. 0.3 kg						Approx. 0.3 kg			

Bold: These preferred versions are available on short notice

* Please indicate when ordering

¹⁾ Available in 3rd quarter of 2005; for the previous version, see the *Rotary Encoders, January 2004* brochure

²⁾ Restricted tolerances: Signal amplitude 0.8 to 1.2 V_{PP}

³⁾ For the correlation between the operating temperature and the shaft speed or power supply, see *General Mechanical Information*

⁴⁾ 150 m/s² with flange socket version

⁵⁾ Not with ERN 480

⁶⁾ With two shaft clamps (only for hollow through shaft)

Mounting Accessories

for ERN/ECN/EQN 400 series

Shaft clamp ring
 By using a second shaft clamp ring, the mechanically permissible speed of rotary encoders with hollow through shaft can be increased to a maximum of 12000 rpm.
 Id. Nr. 540 741-03

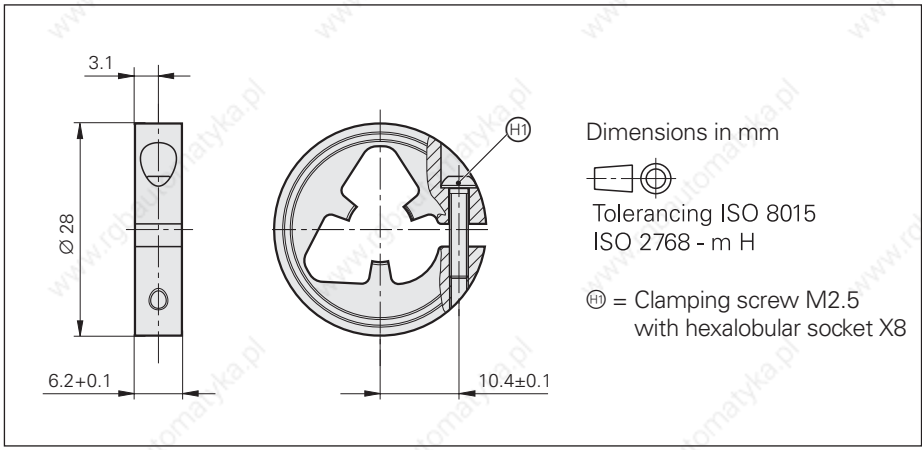

Screwdriver bit
 for HEIDENHAIN shaft couplings,
 for ExN 100/400/1000 shaft clamps,
 for ERO shaft clamps

Width across flats	Length	Id. Nr.
2 (ball head)	70 mm	350378-04
3 (ball head)		350378-08
1.5		350378-01
2		350378-03
2.5		350378-05
4		350378-07
TX8		89 mm 152 mm



Screwdriver
 Adjustable torque
 0.2 Nm to 1 Nm Id. Nr. 350379-01
 0.5 Nm to 5 Nm Id. Nr. 350379-02

ECN/ERN 100 Series

- Rotary encoders with mounted stator coupling
- Hollow through shaft up to Ø 50 mm



ERN 1x0/ECN 113

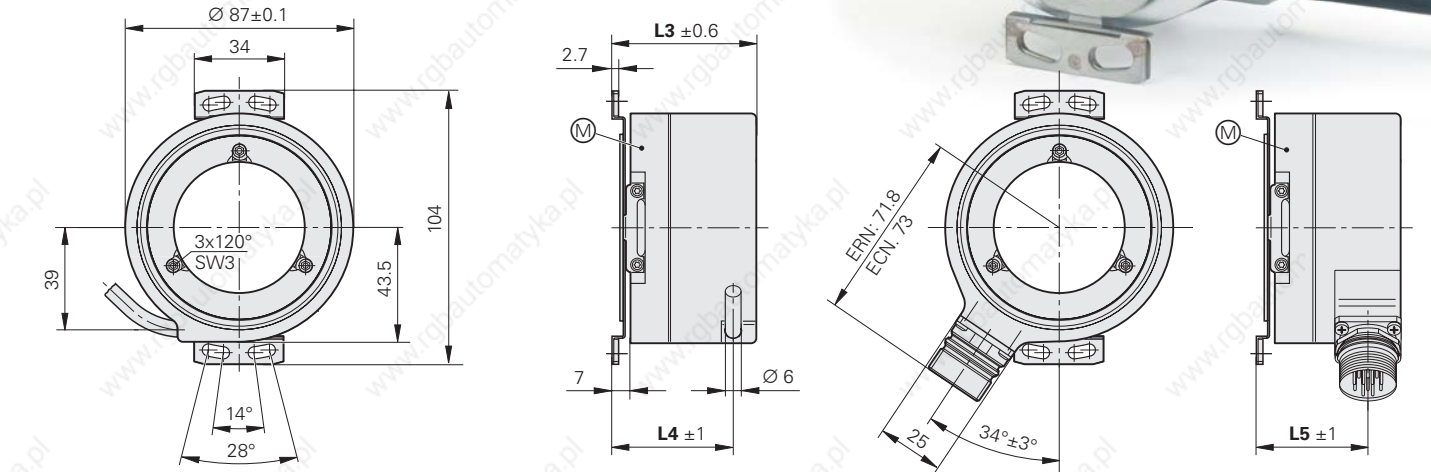

ECN 125 with M12

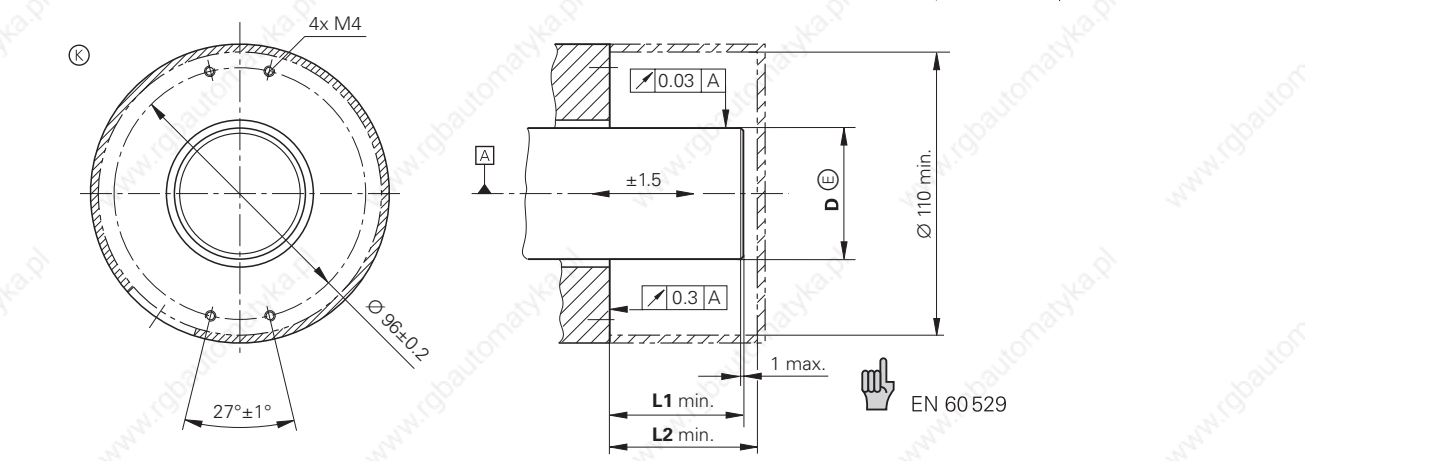
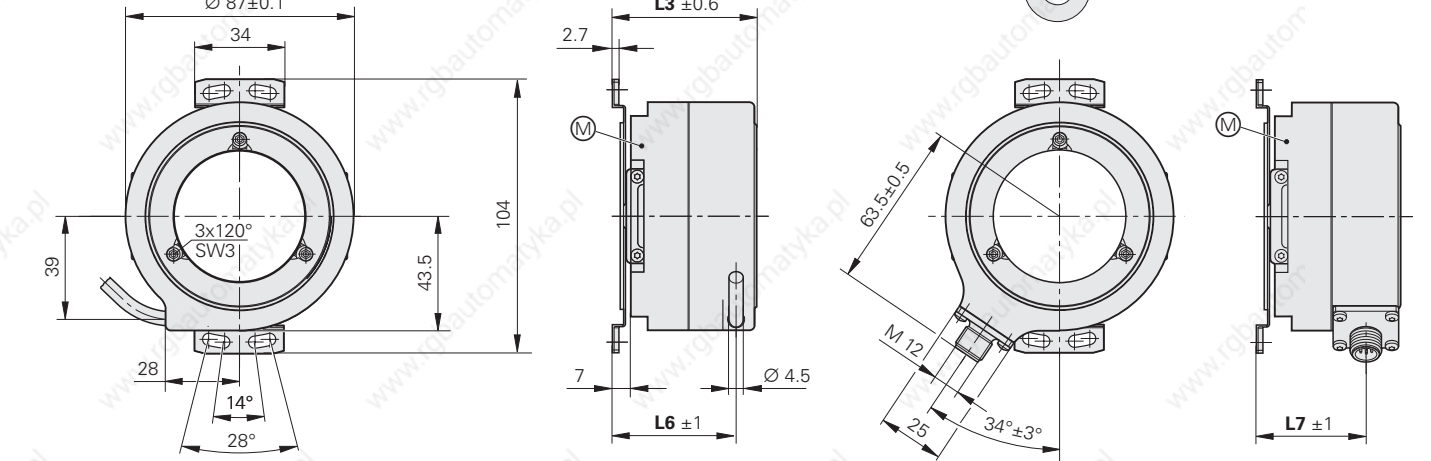

Dimensions in mm



Tolerancing ISO 8015
 ISO 2768 - m H

- Cable radial, also usable axially
- ⊕ = Ball bearing
- ⊙ = Required mating dimensions
- ⊕ = Measuring point for operating temperature
- ↻ Direction of shaft rotation for output signals is described in interface description.

D	Model	L1	L2	L3	L4	L5	L6	L7
Ø 20h7	ERN	46	48.5	45	37	32.5	32	26.5
	ECN	41	43.5	40	32	26.5		
Ø 25h7	ERN	46	48.5	45	37	32.5	32	26.5
	ECN	41	43.5	40	32	26.5		
Ø 38h7	ERN	56	58.5	55	46	42.5	47	41.5
	ECN				47	41.5		
Ø 50h7	ERN	56	58.5	55	46	42.5	47	41.5
	ECN				47	41.5		

	Absolute Singleturn			Incremental		
	ECN 125 ¹⁾	ECN 113 ¹⁾	ECN 113 ¹⁾	ERN 120	ERN 130	ERN 180
Absolute position values*	EnDat 2.2	EnDat 2.2	SSI	–		
Ordering information	EnDat 22	EnDat 02				
Positions per rev.	33554432 (25 bits)	8192 (13 bits)		–		
Code	Pure binary		Gray	–		
Elec. permissible speed at accuracy	n_{\max} for continuous position value	$\leq 660 \text{ rpm} \pm 1 \text{ LSB}$ $n_{\max} / \pm 50 \text{ LSB}$		–		
Calculation time t_{cal}	$\leq 5 \mu\text{s}$	$\leq 0.25 \mu\text{s}$	$\leq 0.5 \mu\text{s}$	–		
Incremental signals	None	$\sim 1 V_{\text{PP}}^{2)}$		\square TTL	\square HTL	$\sim 1 V_{\text{PP}}^{2)}$
Line counts*	–	2048		1000 1024 2048 2500 3600	5000	
Cutoff freq. –3 dB	–	typically $\geq 200 \text{ kHz}$		–		typ. $\geq 180 \text{ kHz}$
Scanning frequency	–	–		$\leq 300 \text{ kHz}$		–
Edge separation a	–	–		$\geq 0.43 \mu\text{s}$		–
System accuracy	$\pm 20''$			1/20 of grating period		
Power supply	3.6 to 5.25 V	5 V \pm 5%	5 V \pm 5% ³⁾	5 V \pm 10%	10 to 30 V	5 V \pm 10%
Current consumption without load	$\leq 200 \text{ mA}$	$\leq 180 \text{ mA}$	$\leq 180 \text{ mA}$	$\leq 150 \text{ mA}$	$\leq 200 \text{ mA}$	$\leq 150 \text{ mA}$
Electrical connection*	<ul style="list-style-type: none"> • Flange socket M12, radial • Cable 1 m/5 m, with coupling M12 	<ul style="list-style-type: none"> • Flange socket M23, radial • Cable 1 m/5 m, with or without coupling M23 		<ul style="list-style-type: none"> • Flange socket M23, radial • Cable 1 m/5 m, with or without coupling M23 		
Shaft*	Hollow through shaft D = 20 mm, 25 mm , 38 mm, 50 mm			Hollow through shaft D = 20 mm, 25 mm , 38 mm, 50 mm		
Mech. perm. speed $n^{4)}$	$D > 30 \text{ mm}$: $\leq 4000 \text{ rpm}$ $D \leq 30 \text{ mm}$: $\leq 6000 \text{ rpm}$			$D > 30 \text{ mm}$: $\leq 4000 \text{ rpm}$ $D \leq 30 \text{ mm}$: $\leq 6000 \text{ rpm}$		
Starting torque at 20 °C (68 °F)	$D > 30 \text{ mm}$: $\leq 0.2 \text{ Nm}$ $D \leq 30 \text{ mm}$: $\leq 0.15 \text{ Nm}$			$D > 30 \text{ mm}$: $\leq 0.2 \text{ Nm}$ $D \leq 30 \text{ mm}$: $\leq 0.15 \text{ Nm}$		
Moment of inertia of rotor	$D = 50 \text{ mm}$	$220 \cdot 10^{-6} \text{ kgm}^2$		$D = 50 \text{ mm}$	$240 \cdot 10^{-6} \text{ kgm}^2$	
	$D = 38 \text{ mm}$	$350 \cdot 10^{-6} \text{ kgm}^2$		$D = 38 \text{ mm}$	$350 \cdot 10^{-6} \text{ kgm}^2$	
	$D = 25 \text{ mm}$	$96 \cdot 10^{-6} \text{ kgm}^2$		$D = 25 \text{ mm}$	$80 \cdot 10^{-6} \text{ kgm}^2$	
	$D = 20 \text{ mm}$	$100 \cdot 10^{-6} \text{ kgm}^2$		$D = 20 \text{ mm}$	$85 \cdot 10^{-6} \text{ kgm}^2$	
Permissible axial motion of measured shaft	$\pm 1.5 \text{ mm}$			$\pm 1.5 \text{ mm}$		
Vibration 55 to 2000 Hz Shock 6 ms	$\leq 200 \text{ m/s}^2$ ⁵⁾ (EN 60068-2-6) $\leq 1000 \text{ m/s}^2$ (EN 60068-2-27)			$\leq 200 \text{ m/s}^2$ ⁵⁾ (EN 60068-2-6) $\leq 1000 \text{ m/s}^2$ (EN 60068-2-27)		
Max. operating temperature ⁴⁾	100 °C			100 °C	85 °C (100 °C at $U_P < 15 \text{ V}$)	100 °C
Min. operating temperature	Flange socket or fixed cable: –40 °C Moving cable: –10 °C			Flange socket or fixed cable: –40 °C Moving cable: –10 °C		
Protection ⁴⁾ EN 60529	IP 64			IP 64		
Weight	0.6 kg to 0.9 kg depending on the hollow shaft			0.6 kg to 0.9 kg depending on the hollow shaft		

Bold: These preferred versions are available on short notice

* Please indicate when ordering

¹⁾ Available in 3rd quarter of 2005; for the previous version, see the *Rotary Encoders, January 2004* brochure

²⁾ Restricted tolerances: Signal amplitude 0.8 to 1.2 V_{PP}

³⁾ 10 to 30 V via connecting cable with voltage converter

⁴⁾ For the correlation between the protection class, shaft speed and operating temperature, see *General Mechanical Information*

⁵⁾ 100 m/s² with flange socket version

ROD 1000 Series

- Rotary encoders for separate shaft coupling
- Compact dimensions
- Synchro flange

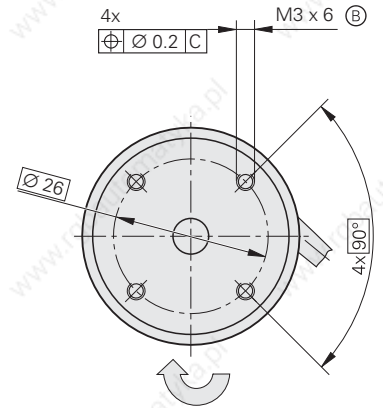
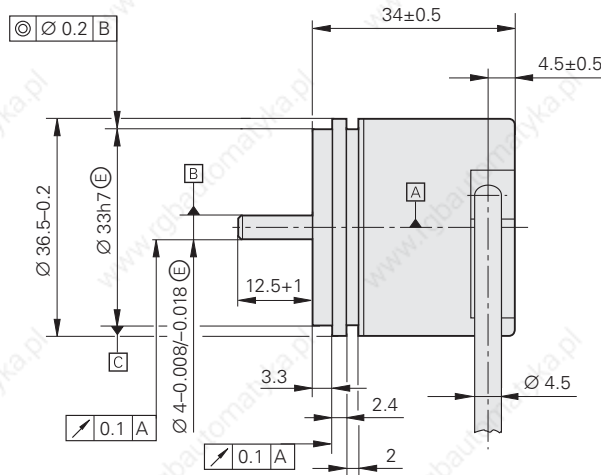
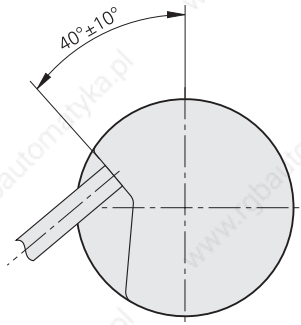

Dimensions in mm



Tolerancing ISO 8015
ISO 2768 - m H

Cable radial, also usable axially

▣ = Ball bearing

⊕ = Threaded mounting hole

↻ Direction of shaft rotation for output signals is described in interface description.

	Incremental								
	ROD 1020			ROD 1030			ROD 1080		
Incremental signals	□ TTL			□ HTL			~ 1 V _{PP} ¹⁾		
Line counts*	100 1000	200 1024	250 360 1250	360 1500	400 2000	500 2048	720 2500	900 3600	
Cutoff freq. -3 dB	-			-			≥ 180 kHz		
Scanning frequency	≤ 300 kHz			≤ 160 kHz			-		
Edge separation a	≥ 0.43 μs			≥ 0.78 μs			-		
Power supply*	5 V ± 10%			10 to 30 V			5 V ± 10%		
Current consumption without load	≤ 150 mA			≤ 150 mA			≤ 150 mA		
Electrical connection*	Cable 1 m/5 m, with or without coupling M23								
Max. cable length	100 m						150 m		
Shaft*	Solid shaft D = 4 mm								
Mechanically permissible speed	10000 rpm								
Starting torque	≤ 0.001 Nm (at 20 °C)								
Moment of inertia of rotor	0.45 · 10 ⁻⁶ kgm ²								
Shaft load	Axial 5 N Radial 10 N at shaft end								
Vibration 55 to 2000 Hz	≤ 100 m/s ² (EN 60068-2-6)								
Shock 6 ms	≤ 1000 m/s ² (EN 60068-2-27)								
Max. operating temperature	100 °C			70 °C			100 °C		
Min. operating temperature	Fixed cable: -40 °C Moving cable: -10 °C								
Protection EN 60529	IP 64								
Weight	Approx. 0.09 kg								

Bold: These preferred versions are available on short notice

* Please indicate when ordering

¹⁾ Restricted tolerances: Signal amplitude 0.8 to 1.2 V_{PP}

Mounting Accessories

Fixing clamps for encoders of the ROD 1000 series
(3 per encoder)
Id. Nr. 200032-02

Shaft coupling
See *Shaft Couplings*

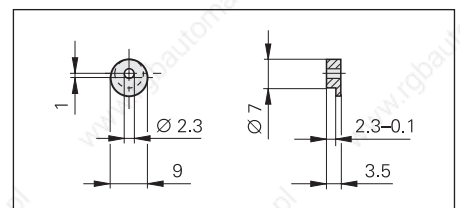

ROC/ROQ/ROD 400 Series with Synchro Flange

Rotary encoders for separate shaft coupling



ROC/ROQ/ROD 4xx

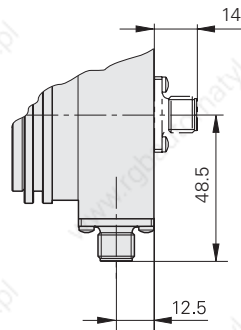
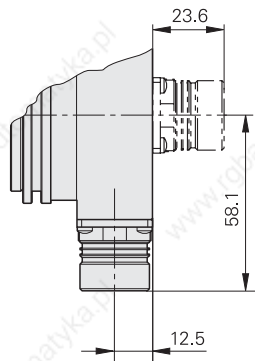
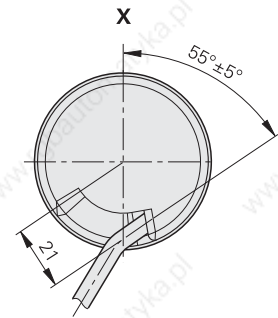
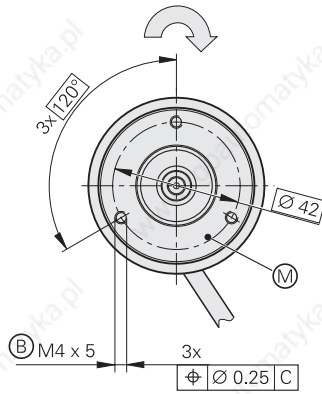
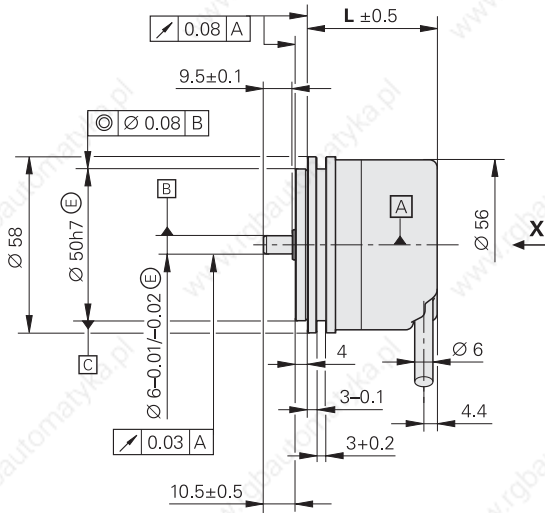

	L
ROD ROC/ROQ 512 lines	42.7
ROC/ROQ 2048 lines ROC 425/ROQ 437	43.2

ROC 413/ROQ 425 with PROFIBUS DP

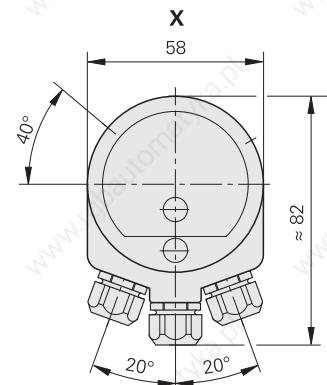
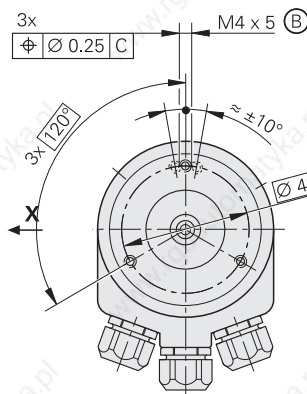
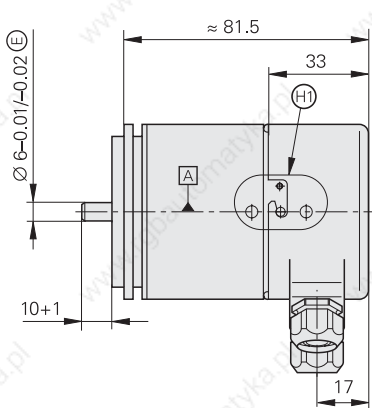

Dimensions in mm



Tolerancing ISO 8015
ISO 2768 - m H

28

Cable radial, also usable axially

Ⓐ = Ball bearing

Ⓑ = Threaded mounting hole

Ⓒ = Shown rotated by 40°

↻ Direction of shaft rotation for output signals is described in interface description.

	Absolute								Incremental			
	Singletum				Multitum							
	ROC 425 ¹⁾	ROC 413 ¹⁾	ROC 4101) ROC 4121) ROC 413 ¹⁾	ROC 413	ROQ 437 ¹⁾	ROQ 425 ¹⁾	ROQ 4241) ROQ 425 ¹⁾	ROQ 425	ROD 426	ROD 466	ROD 436	ROD 486
Absolute position values*	EnDat 2.2	EnDat 2.2	SSI	PROFIBUS-DP	EnDat 2.2	EnDat 2.2	SSI	PROFIBUS-DP	-			
Ordering information	EnDat 22	EnDat 02			EnDat 22	EnDat 02						
Positions per rev.	33554432 (25 bits)	8192 (13 bits)	1024 (10 bits) 4096 (12 bits) 8192 (13 bits)	8192 (13 bits) ³⁾	33554432 (25 bits)	8192 (13 bits)	4096 (12 bits) 8192 (13 bits)	8192 (13 bits) ³⁾	-			
Revolutions	-				4096				4096 ³⁾			
Code	Pure binary		Gray	Pure binary	Pure binary		Gray	Pure binary	-			
Elec. permissible speed/Accuracy	≤ 12000 rpm for continuous position values	512 lines: ≤ 5000 rpm/± 1 LSB 2048 lines: ≤ 1500 rpm/± 1 LSB ≤ 12000 rpm/± 50 LSB			≤ 12000 rpm for continuous position values	512 lines: ≤ 5000 rpm/± 1 LSB ≤ 10000 rpm/± 100 LSB 2048 lines: ≤ 1500 rpm/± 1 LSB ≤ 10000 rpm/± 50 LSB			-			
Calculation time t_{cal}	≤ 5 μs	≤ 0.25 μs	≤ 0.5 μs	-	≤ 5 μs	≤ 0.25 μs	≤ 0.5 μs	-	-			
Incremental signals	None	$\sim 1 V_{PP}$ ²⁾		-	None	$\sim 1 V_{PP}$ ²⁾		-	\square TTL	\square HTL	$\sim 1 V_{PP}$ ²⁾	
Line counts*	-	512 2048	512	512 (internal only)	-	512 2048	512	512 (internal only)	50 100 150 200 250 360	500 512 720	-	
Cutoff freq. -3 dB Scanning frequency Edge separation a	-	512 lines: ≥ 100 kHz; 2048 lines: ≥ 200 kHz		-	-	512 lines: ≥ 100 kHz; 2048 lines: ≥ 200 kHz		-	-	1000 1024 1250 1500 1800 2000 2048 2500 3600 4096 5000 6000 ⁵⁾ 8192 ⁵⁾ 9000 ⁵⁾ 10000 ⁵⁾	-	
System accuracy	± 20"	512 lines: ± 60"; 2048 lines: ± 20"		± 60"	± 20"	512 lines: ± 60"; 2048 lines: ± 20"		1/20 of grating period				
Power supply*	3.6 to 5.25 V	5 V ± 5 %	5 V ± 5 % or 10 to 30 V	10 to 30 V	3.6 to 5.25 V	5 V ± 5 %	5 V ± 5 % or 10 to 30 V	10 to 30 V	5 V ± 10 %	10 to 30 V	10 to 30 V	5 V ± 10 %
Current consumption without load	≤ 150 mA	≤ 160 mA	≤ 160 mA	≤ 125 mA at 24 V	≤ 180 mA	≤ 200 mA	≤ 200 mA	≤ 125 mA at 24 V	120 mA	100 mA	150 mA	120 mA
Electrical connection*	• Flange socket M12, radial • Cable 1 m, with coupling M12	• Flange socket M23, axial or radial • Cable 1 m/5 m, with or without coupling M23		Screw terminals; radial cable exit	• Flange socket M12, radial • Cable 1 m, with coupling M12	• Flange socket M23, axial or radial • Cable 1 m/5 m, with or without coupling M23		Screw terminals; radial cable exit	• Flange socket M23, radial and axial • Cable 1 m/5 m, with or without coupling M23			
Shaft	Solid shaft D = 6 mm								Solid shaft D = 6 mm			
Mech. permissible speed	≤ 12000 rpm								≤ 16000 rpm			
Starting torque	≤ 0.01 Nm (at 20 °C)								≤ 0.01 Nm (at 20 °C)			
Moment of inertia of rotor	2.7 · 10 ⁻⁶ kgm ²			3.6 · 10 ⁻⁶ kgm ²	2.7 · 10 ⁻⁶ kgm ²			3.8 · 10 ⁻⁶ kgm ²	2.7 · 10 ⁻⁶ kgm ²			
Shaft load ⁶⁾	Axial 10 N/radial 20 N at shaft end								Axial 10 N/radial 20 N at shaft end			
Vibration 55 to 2000 Hz Shock 6 ms/2 ms	≤ 300 m/s ² (EN 60068-2-6) ≤ 1000 m/s ² /≤ 2000 m/s ² (EN 60068-2-27)								≤ 300 m/s ² (EN 60068-2-6) ≤ 1000 m/s ² /≤ 2000 m/s ² (EN 60068-2-27)			
Max. operat. temperature	$U_P = 5 V$: 100 °C; $U_P = 10$ to 30 V: 85 °C			60 °C	$U_P = 5 V$: 100 °C; $U_P = 10$ to 30 V: 85 °C			60 °C	100 °C	70 °C	100 °C	
Min. operat. temperature	Flange socket or fixed cable: -40 °C; Moving cable: -10 °C			-20 °C	Flange socket or fixed cable: -40 °C; Moving cable: -10 °C			-20 °C	Flange socket or fixed cable: -40 °C; Moving cable: -10 °C			
Protection IEC 60529	IP 67 at housing; IP 64 at shaft end ⁴⁾								IP 67 at housing; IP 64 at shaft end ⁴⁾			
Weight	Approx. 0.35 kg								Approx. 0.3 kg			

Bold: These preferred versions are available on short notice

* Please indicate when ordering

¹⁾ Available in 3rd quarter of 2005; for the previous version, see the *Rotary Encoders, January 2004* brochure

²⁾ Restricted tolerances: Signal amplitude 0.8 to 1.2 V_{PP}

³⁾ These functions are programmable

⁴⁾ IP 66 upon request

⁵⁾ Only on ROD 426, ROD 466 through integrated signal doubling

⁶⁾ Also see *Mechanical Design and Installation*

Mounting Accessories

for ROC/ROQ/ROD 400 series with synchro flange

Adapter flange
(electrically nonconducting)
Id. Nr. 257 044-01

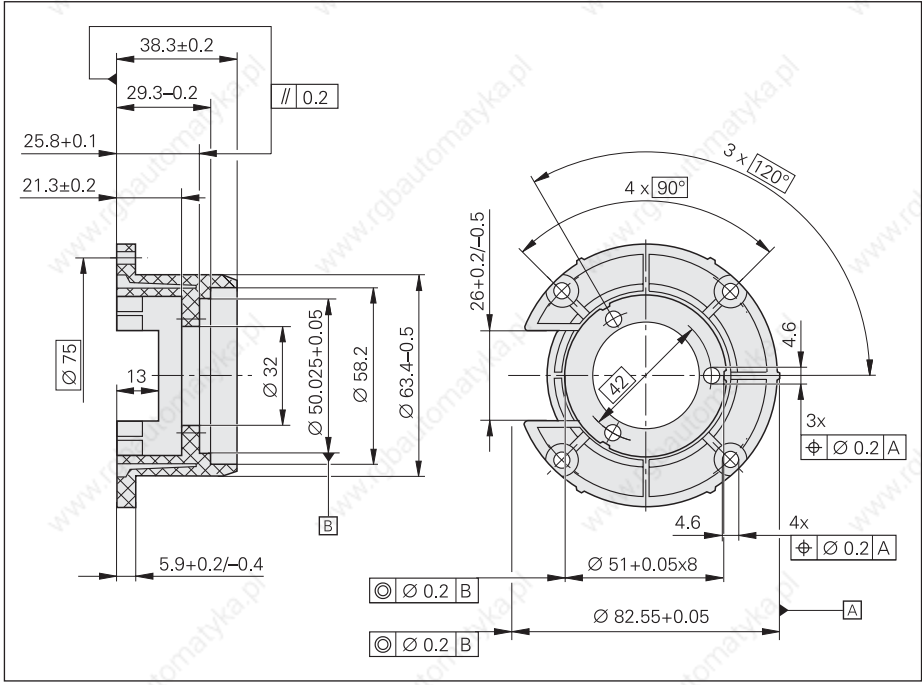

Fixing clamps
(3 per encoder)
Id. Nr. 200 032-01

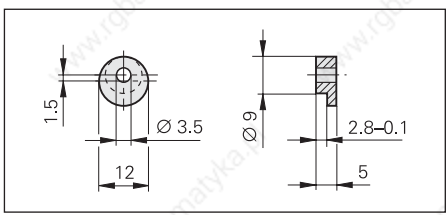

Shaft coupling
See Shaft Couplings

ROC 415, ROC 417

- Rotary encoders for separate shaft coupling
- Synchro flange
- High absolute resolution
32768 position values per revolution (15 bits) or
131072 position values per revolution (17 bits)

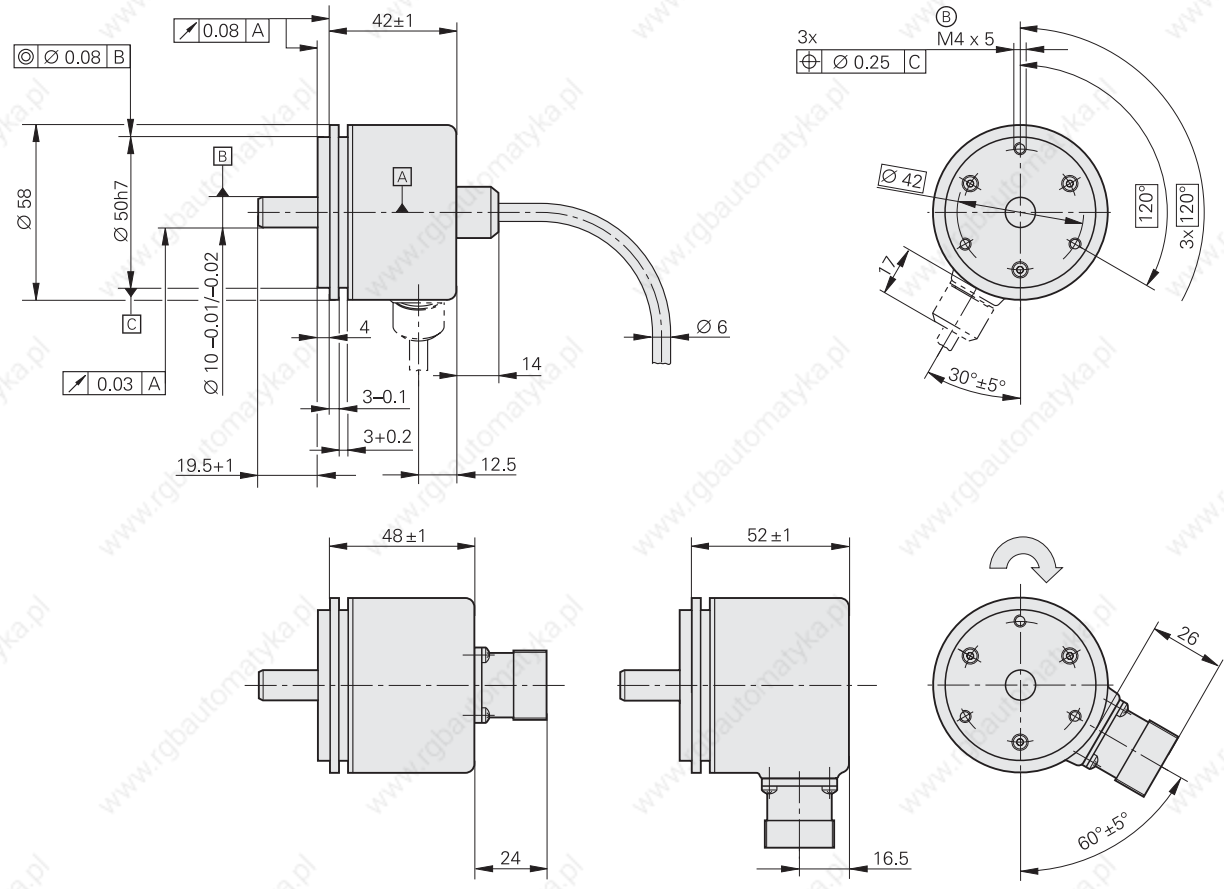

Dimensions in mm

 Tolerancing ISO 8015
 ISO 2768 - m H

Cable radial, also usable axially
 = Ball bearing
 = Threaded mounting hole
 Direction of shaft rotation for output signals is described in interface description.

	Absolute	ROC 415	ROC 417
Absolute position values	EnDat 2.1		
Positions per rev.	32 768 (15 bits)		131 072 (17 bits)
Code	Pure binary		
Elec. permissible speed at accuracy	60 rpm/± 2 LSB 200 rpm/± 50 LSB		
Calculation time t_{cal}	≤ 0.25 μs		
Incremental signals	~ 1 V _{PP} ¹⁾		
Line counts	8192		
Cutoff freq. -3 dB	≥100 kHz		
Power supply	5 V ± 5%		
Current consumption without load	≤ 250 mA		
Electrical connection*	<ul style="list-style-type: none"> • Flange socket M23, axial or radial • Cable 1 m/5 m, with or without coupling M23 		
Shaft	Solid shaft D = 10 mm		
Mechanically permissible speed	≤ 10 000 rpm		
Starting torque	≤ 0.025 Nm (at 20 °C)		
Moment of inertia of rotor	3.6 · 10 ⁻⁶ kgm ²		
Shaft load	Axial 10 N Radial 20 N at shaft end		
Vibration 55 to 2000 Hz	≤ 100 m/s ² (EN 60 068-2-6)		
Shock 6 ms	≤ 1000 m/s ² (EN 60 068-2-27)		
Max. operating temperature	80 °C		
Min. operating temperature	Flange socket or fixed cable: -40 °C Moving cable: -10 °C		
Protection EN 60529	IP 67 at housing IP 66 at shaft inlet		
Weight	Approx. 0.4 kg		

Bold: These preferred versions are available on short notice

* Please indicate when ordering

¹⁾ Restricted tolerances: Signal amplitude 0.8 to 1.2 V_{PP}

Mounting Accessories

Fixing clamps

(3 per encoder)
Id. Nr. 200 032-01

Shaft coupling

See *Shaft Couplings*

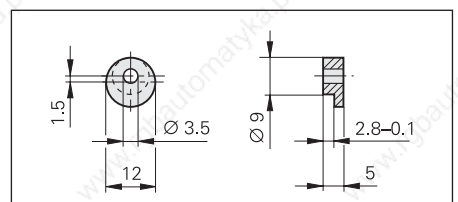

ROC/ROQ/ROD 400 Series with Clamping Flange

Rotary encoders for separate shaft coupling



ROC/ROQ/ROD 4xx

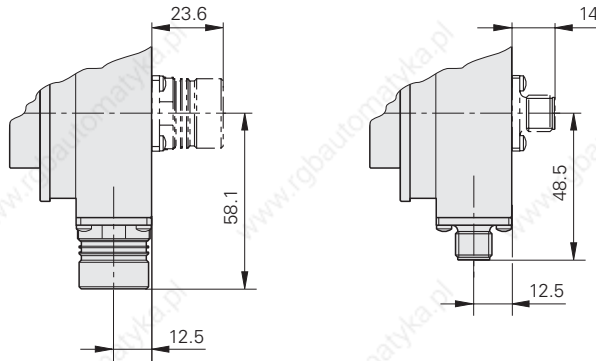
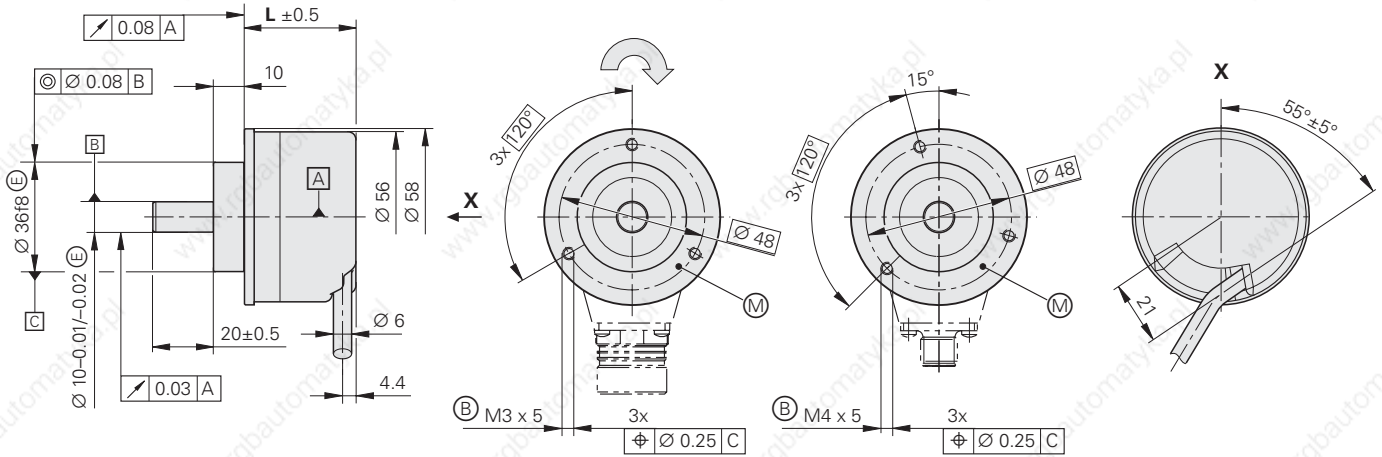

	L
ROD ROC/ROQ 512 lines	36.7
ROC/ROQ 2048 lines ROC 425/ROQ 437	37.2

ROC 413/ROQ 425 with PROFIBUS DP

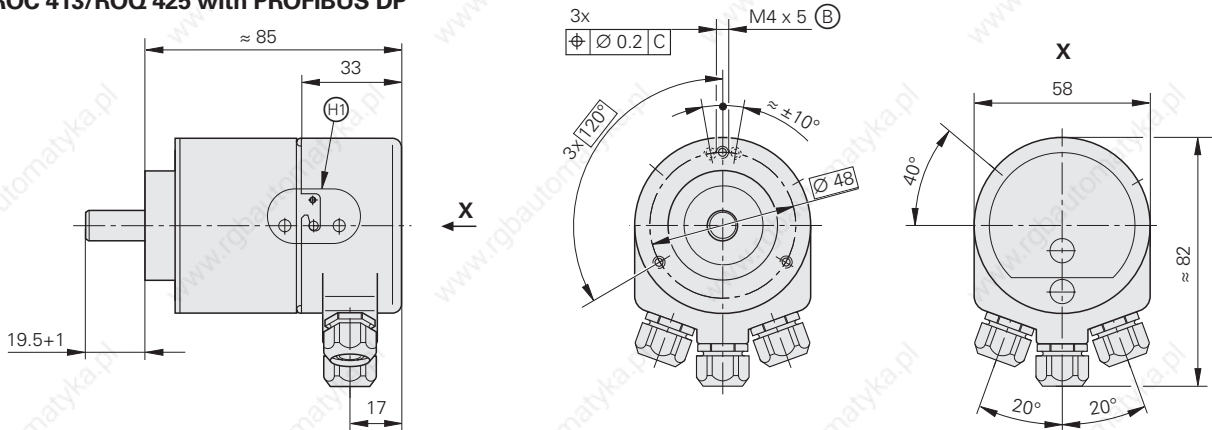

Dimensions in mm



Tolerancing ISO 8015
ISO 2768 - m H

Cable radial, also usable axially





▣ = Ball bearing

⊕ = Threaded mounting hole

⊙ = Measuring point for operating temperature

⊕ = Shown rotated by 40°

↻ Direction of shaft rotation for output signals is described in interface description.

	Absolute								Incremental		
	Singletum				Multitum				ROD 420	ROD 430	ROD 480
	ROC 425 ¹⁾	ROC 413 ¹⁾	ROC 413 ¹⁾	ROC 413	ROQ 437 ¹⁾	ROQ 425 ¹⁾	ROQ 4241) ROQ 425 ¹⁾	ROQ 425			
Absolute position values*	EnDat 2.2; Var. 22	EnDat 2.2; Var. 02	SSI	PROFIBUS-DP	EnDat 2.2; Var. 22	EnDat 2.2; Var. 02	SSI	PROFIBUS-DP	-		
Ordering information	EnDat 22	EnDat 02			EnDat 22	EnDat 02					
Positions per rev.	33 554 432 (25 bits)	8192 (13 bits)		8192 (13 bits) ³⁾	33 554 432 (25 bits)	8192 (13 bits)	4096 (12 bits) 8192 (13 bits)	8192 (13 bits) ³⁾	-		
Revolutions	-				4096			4096 ³⁾	-		
Code	Pure binary		Gray	Pure binary	Pure binary		Gray	Pure binary	-		
Elec. permissible speed/Accuracy	≤ 12 000 rpm for continuous position values	≤ 5000 rpm/± 1 LSB ≤ 12 000 rpm/± 100 LSB			≤ 12 000 rpm for continuous position values	≤ 5000 rpm/± 1 LSB ≤ 10 000 rpm/± 100 LSB			-		
Calculation time t_{cal}	≤ 5 μs	≤ 0.25 μs	≤ 0.5 μs	-	≤ 5 μs	≤ 0.25 μs	≤ 0.5 μs	-	-		
Incremental signals	None	 1 V _{PP} ²⁾		-	None	 1 V _{PP} ²⁾		-	 TTL	 HTL	 1 V _{PP} ²⁾
Line counts*	-	512		512 (internal only)	-	512		512 (internal only)	50 100 150 200 250 360 500 512 720	-	
Cutoff freq. -3 dB Scanning frequency Edge separation a	- - -	≥ 100 kHz - -		-	- - -	≥ 100 kHz - -		-	- ≤ 300 kHz ≥ 0.43 μs	≥ 180 kHz - -	
System accuracy	± 20"	± 60"			± 20"	± 60"			1/20 of grating period		
Power supply*	3.6 to 5.25 V	5 V ± 5 %	5 V ± 5 % or 10 to 30 V	10 to 30 V	3.6 to 5.25 V	5 V ± 5 %	5 V ± 5 % or 10 to 30 V	10 to 30 V	5 V ± 10 %	10 to 30 V	5 V ± 10 %
Current consumption without load	≤ 150 mA	≤ 160 mA	≤ 160 mA	≤ 125 mA at 24 V	≤ 180 mA	≤ 200 mA	≤ 200 mA	≤ 125 mA at 24 V	120 mA	150 mA	120 mA
Electrical connection*	• Flange socket M12, radial • Cable 1 m, with coupling M12	• Flange socket M23, axial or radial • Cable 1 m/5 m, with or without coupling M23		Screw terminals; radial cable exit	• Flange socket M12, radial • Cable 1 m, with coupling M12	• Flange socket M23, axial or radial • Cable 1 m/5 m, with or without coupling M23		Screw terminals; radial cable exit	• Flange socket M23, radial and axial • Cable 1 m/5 m, with or without coupling M23		
Shaft	Solid shaft D = 10 mm								Solid shaft D = 10 mm		
Mech. permissible speed	≤ 12 000 rpm								≤ 12 000 rpm		
Starting torque	≤ 0.01 Nm (at 20 °C)								≤ 0.01 Nm (at 20 °C)		
Moment of inertia of rotor	2.8 · 10 ⁻⁶ kgm ²		3.6 · 10 ⁻⁶ kgm ²	2.8 · 10 ⁻⁶ kgm ²	3.6 · 10 ⁻⁶ kgm ²			2.6 · 10 ⁻⁶ kgm ²			
Shaft load ⁵⁾	Axial 10 N/radial 20 N at shaft end								Axial 10 N/radial 20 N at shaft end		
Vibration 55 to 2000 Hz Shock 6 ms/2 ms	≤ 300 m/s ² (EN 60 068-2-6) ≤ 1000 m/s ² /≤ 2000 m/s ² (EN 60 068-2-27)								≤ 300 m/s ² (EN 60 068-2-6) ≤ 1000 m/s ² /≤ 2000 m/s ² (EN 60 068-2-27)		
Max. operating temperature	$U_P = 5 V$: 100 °C $U_P = 10$ to 30 V: 85 °C		60 °C	$U_P = 5 V$: 100 °C $U_P = 10$ to 30 V: 85 °C	60 °C			100 °C			
Min. operating temperature	Flange socket or fixed cable: -40 °C Moving cable: -10 °C		-20 °C	Flange socket or fixed cable: -40 °C Moving cable: -10 °C	-20 °C			Flange socket or fixed cable: -40 °C Moving cable: -10 °C			
Protection EN 60 529	IP 67 at housing; IP 64 at shaft end ⁴⁾								IP 67 at housing; IP 64 at shaft end ⁴⁾		
Weight	Approx. 0.35 kg								Approx. 0.3 kg		

Bold: These preferred versions are available on short notice

* Please indicate when ordering

¹⁾ Available in 3rd quarter of 2005; for the previous version, see the *Rotary Encoders, January 2004* brochure

²⁾ Restricted tolerances: Signal amplitude 0.8 to 1.2 V_{PP}

³⁾ These functions are programmable

⁴⁾ IP 66 upon request

⁵⁾ Also see *Mechanical Design and Installation*

Mounting Accessories

for ROC/ROQ/ROD 400 series with clamping flange

Mounting flange

Id. Nr. 201 437-01

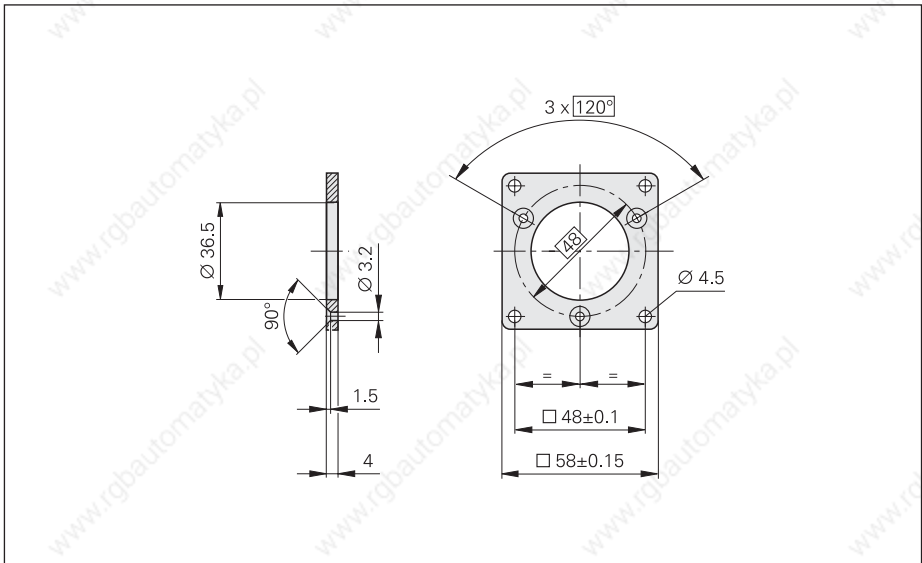

Mounting bracket

Id. Nr. 324 322-01

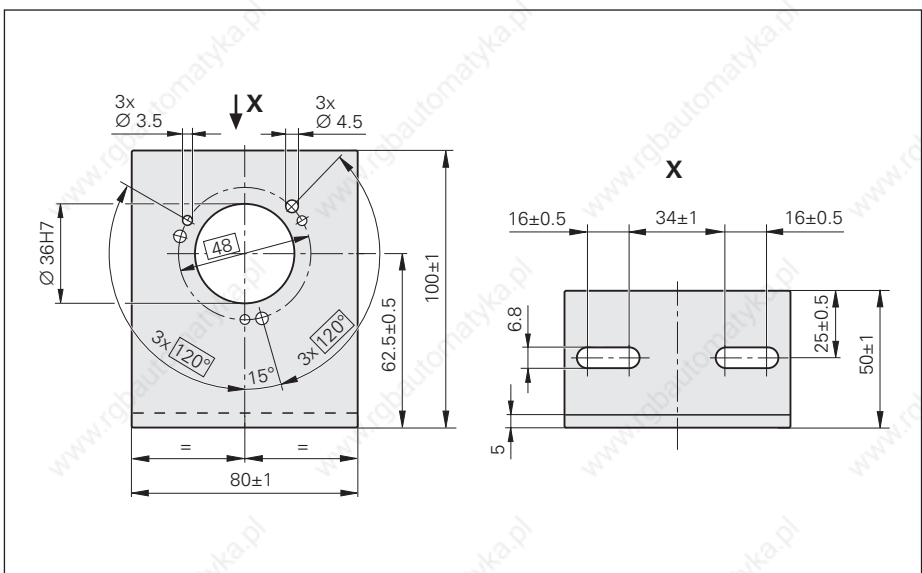

Shaft coupling

See Shaft Couplings

Interfaces

~ 1 V_{PP} Incremental Signals

HEIDENHAIN encoders with ~ 1 V_{PP} interface provide voltage signals that can be highly interpolated.

The sinusoidal **incremental signals** A and B are phase-shifted by 90° elec. and have an amplitude of typically 1 V_{PP}. The illustrated sequence of output signals—with B lagging A—applies for the direction of motion shown in the dimension drawing.

The **reference mark signal** R has a usable component G of approx. 0.5 V. Along with the reference mark, the output signal can be reduced by up to 1.7 V to an idle level H. This must not cause the subsequent electronics to overdrive. At the lowered signal level, signal peaks can also appear with the amplitude G.

The data on **signal amplitude** apply when the power supply given in the specifications is connected to the encoder. They refer to a differential measurement at the 120 ohm terminating resistor between the associated outputs. The signal amplitude decreases with increasing frequency. The **cutoff frequency** indicates the scanning frequency at which a certain percentage of the original signal amplitude is maintained:

- 3 dB cutoff frequency: 70 % of the signal amplitude
- 6 dB cutoff frequency: 50 % of the signal amplitude

Interpolation/resolution/measuring step
The output signals of the 1 V_{PP} interface are usually interpolated in the subsequent electronics in order to attain sufficiently high resolutions. For **velocity control**, interpolation factors are commonly over 1000 in order to receive usable velocity information even at low speeds.

Measuring steps for **position measurement** are recommended in the specifications. For special applications, other resolutions are also possible.

Short circuit stability
A temporary short circuit of one output to 0 V or 5 V does not cause encoder failure, but it is not a permissible operating condition.

Short circuit at	20 °C	125 °C
One output	< 3 min	< 1 min
All outputs	< 20 s	< 5 s

Interface	Sinusoidal voltage signals ~ 1 V _{PP}
Incremental signals	2 sinusoidal signals A and B Signal level M: 0.6 to 1.2 V _{PP} ; typically 1 V _{PP} Asymmetry P - N /2M: ≤ 0.065 Amplitude ratio M _A /M _B : 0.8 to 1.25 Phase angle φ ₁ + φ ₂ /2: 90° ± 10° elec.
Reference mark signal	1 or more signal peaks R Usable component G: 0.2 to 0.85 V Quiescent value H: 0.04 V to 1.7 V Switching threshold E, F: ≥ 40 mV Zero crossovers K, L: 180° ± 90° elec.
Connecting cable	HEIDENHAIN cable with shielding PUR [4(2 x 0.14 mm ²) + (4 x 0.5 mm ²)]
Cable lengths	Max. 150 m distributed capacitance 90 pF/m Propagation time 6 ns/m

Any limited tolerances in the encoders are listed in the specifications.

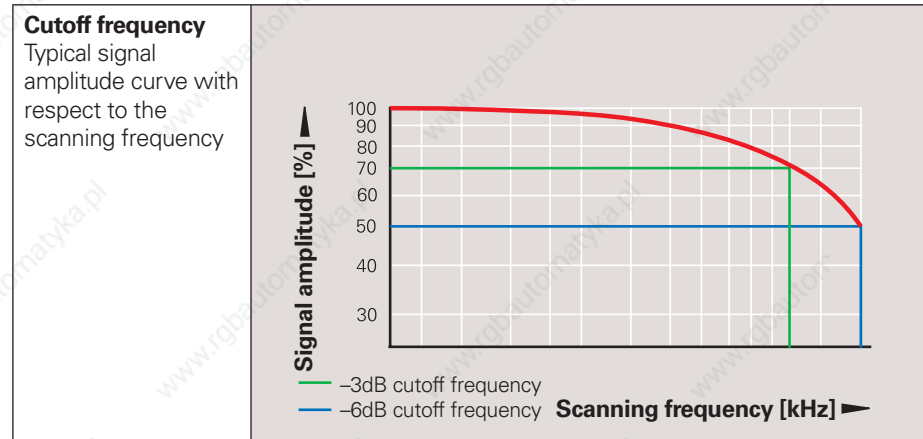
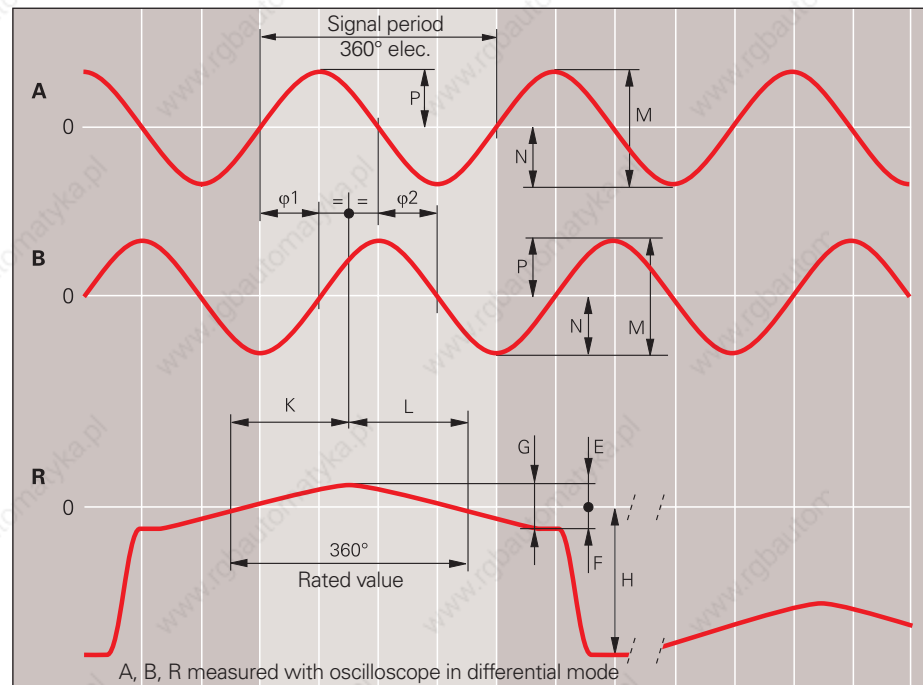

Input circuitry of the subsequent electronics

Dimensioning

Operational amplifier MC 34074

$Z_0 = 120 \Omega$

$R_1 = 10 \text{ k}\Omega$ and $C_1 = 100 \text{ pF}$

$R_2 = 34.8 \text{ k}\Omega$ and $C_2 = 10 \text{ pF}$

$U_B = \pm 15 \text{ V}$

U_1 approx. U_0

-3dB cutoff frequency of circuitry

Approx. 450 kHz

Approx. 50 kHz with $C_1 = 1000 \text{ pF}$

and $C_2 = 82 \text{ pF}$

This circuit variant does reduce the bandwidth of the circuit, but in doing so it improves its noise immunity.

Circuit output signals

$U_a = \text{approx. } 3.48 V_{PP}$

Gain 3.48-fold

Signal monitoring

A threshold sensitivity of 250 mV_{PP} is to be provided for monitoring the 1 V_{PP} incremental signals.

Incremental signals Reference mark signal

$R_a < 100 \Omega$, typ. 24 Ω

$C_a < 50 \text{ pF}$

$\Sigma I_a < 1 \text{ mA}$

$U_0 = 2.5 \text{ V} \pm 0.5 \text{ V}$
(relative to 0 V of the power supply)

Encoder

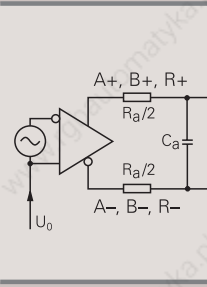

Subsequent electronics

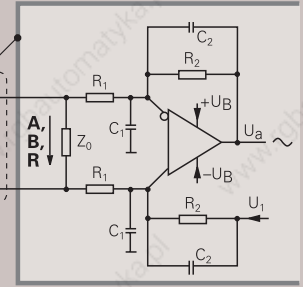

Pin layout

12-pin coupling M23					12-pin connector M23					15-pin D-sub connector for IK 115/IK 215 or on encoder				
Power supply					Incremental signals					Other signals				
12	2	10	11	5	6	8	1	3	4	9	7	/	/	/
4	12	2	10	1	9	3	11	14	7	5/8/13/15	14	/	/	/
U_P	Sensor U_P	0V	Sensor 0V	A+	A-	B+	B-	R+	R-	Vacant	Vacant	Vacant		
Brown/ Green	Blue	White/ Green	White	Brown	Green	Gray	Pink	Red	Black	/	Violet	Yellow		

Shield on housing; U_P = Power supply voltage

Sensor: The sensor line is connected internally with the corresponding power line

Interfaces

□□ TTL Incremental Signals

HEIDENHAIN encoders with □□ TTL interface incorporate electronics that digitize sinusoidal scanning signals with or without interpolation.

The **incremental signals** are transmitted as the square-wave pulse trains U_{a1} and U_{a2} , phase-shifted by 90° elec. The **reference mark signal** consists of one or more reference pulses U_{a0} , which are gated with the incremental signals. In addition, the integrated electronics produce their **inverse signals** $\overline{U_{a1}}$, $\overline{U_{a2}}$ and $\overline{U_{a0}}$ for noise-proof transmission. The illustrated sequence of output signals—with U_{a2} lagging U_{a1} —applies for the direction of motion shown in the dimension drawing.

The **fault-detection signal** $\overline{U_{aS}}$ indicates fault conditions such as breakage of the power line or failure of the light source. It can be used for such purposes as machine shut-off during automated production.

The distance between two successive edges of the incremental signals U_{a1} and U_{a2} through 1-fold, 2-fold or 4-fold evaluation is one **measuring step**.

The subsequent electronics must be designed to detect each edge of the square-wave pulse. The minimum **edge separation a** listed in the *Specifications* applies for the illustrated input circuitry with a cable length of 1 m, and refers to a measurement at the output of the differential line receiver. Propagation-time differences in cables additionally reduce the edge separation by 0.2 ns per meter of cable length. To prevent counting error, design the subsequent electronics to process as little as 90% of the resulting edge separation.

The max. permissible **shaft speed** or **traversing velocity** must never be exceeded.

The permissible **cable length** for transmission of the TTL square-wave signals to the subsequent electronics depends on the edge separation a . It is max. 100 m, or 50 m for the fault detection signal. This requires, however, that the power supply (see *Specifications*) be ensured at the encoder. The sensor lines can be used to measure the voltage at the encoder and, if required, correct it with an automatic system (remote sense power supply).

Interface	Square-wave signals □□ TTL
Incremental signals	2 TTL square-wave signals U_{a1}, U_{a2} and their inverted signals $\overline{U_{a1}}$, $\overline{U_{a2}}$
Reference mark signal Pulse width Delay time	1 or more square-wave pulses U_{a0} and their inverted pulses $\overline{U_{a0}}$ 90° elec. (other widths available on request); LS 323: ungated $ t_d \leq 50$ ns
Fault detection signal Pulse width	1 TTL square-wave pulse $\overline{U_{aS}}$ Improper function: LOW (upon request: U_{a1}/U_{a2} at high impedance) Proper function: HIGH $t_s \geq 20$ ms
Signal level	Differential line driver as per EIA standard RS 422 $U_H \geq 2.5$ V at $-I_H = 20$ mA $U_L \leq 0.5$ V at $I_L = 20$ mA
Permissible load	$Z_0 \geq 100 \Omega$ between associated outputs $ I_L \leq 20$ mA max. load per output $C_{load} \leq 1000$ pF with respect to 0 V Outputs protected against short circuit to 0 V
Switching times (10% to 90%)	$t_r / t_f \leq 30$ ns (typically 10 ns) with 1 m cable and recommended input circuitry
Connecting cable Cable lengths Propagation time	HEIDENHAIN cable with shielding PUR [4(2 × 0.14 mm ²) + (4 × 0.5 mm ²)] Max. 100 m ($\overline{U_{aS}}$ max. 50 m) distributed capacitance 90 pF/m 6 ns/m

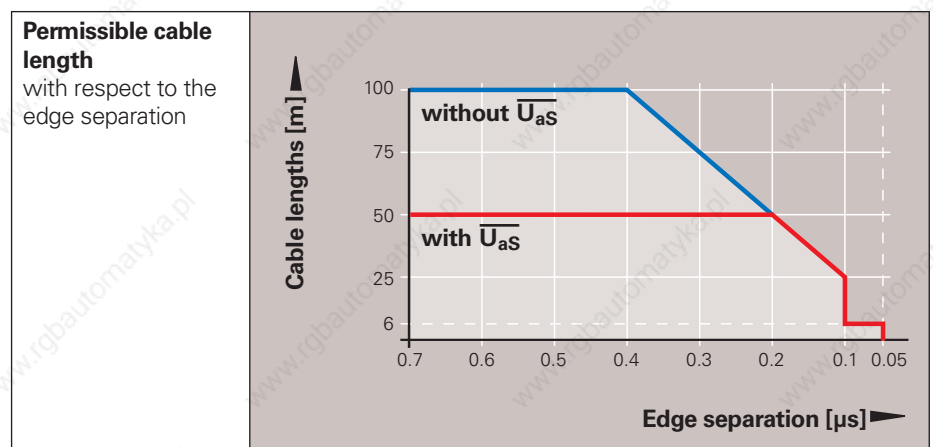
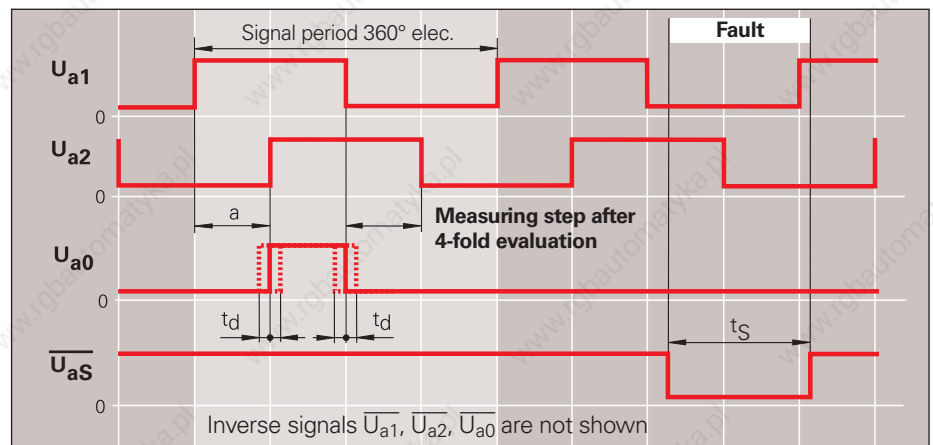

Input circuitry of the subsequent electronics

Dimensioning

IC₁ = Recommended differential line receiver
 DS 26 C 32 AT
 Only for a > 0.1 μs:
 AM 26 LS 32
 MC 3486
 SN 75 ALS 193

R₁ = 4.7 kΩ
 R₂ = 1.8 kΩ
 Z₀ = 120 Ω
 C₁ = 220 pF (serves to improve noise immunity)

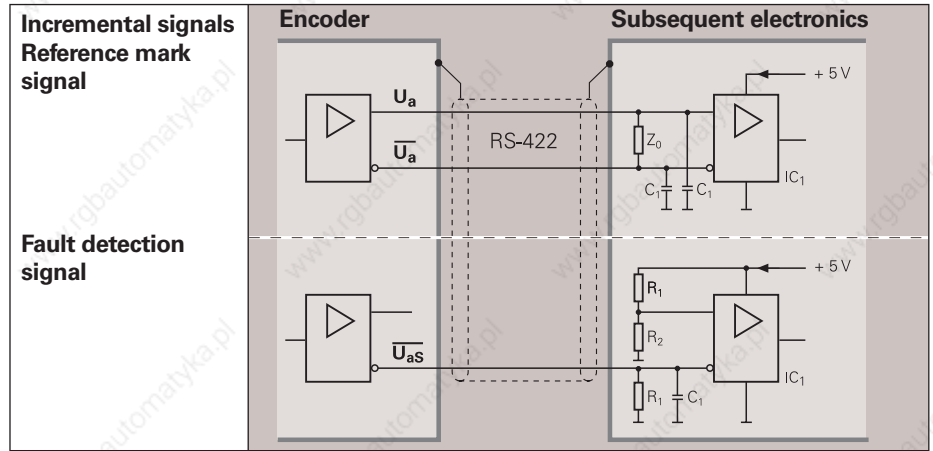

Pin layout

12-pin flange socket or coupling M23 					12-pin connector M23 								
15-pin D-sub connector at encoder 					12-pin PCB connector 								
	Power supply				Incremental signals						Other signals		
	12	2	10	11	5	6	8	1	3	4	7	/	9
	4	12	2	10	1	9	3	11	14	7	13	5/6/8	15
	2a	2b	1a	1b	6b	6a	5b	5a	4b	4a	3a	3b	/
	U _P	Sensor U _P	0V	Sensor 0V	U _{a1}	U _{a1}	U _{a2}	U _{a2}	U _{a0}	U _{a0}	U _{aS} ¹⁾	Vacant	Vacant ²⁾
	Brown/ Green	Blue	White/ Green	White	Brown	Green	Gray	Pink	Red	Black	Violet	-	Yellow

Shield on housing; U_P = Power supply voltage

Sensor: The sensor line is connected internally with the corresponding power line

¹⁾ LS 323/ERO 14xx: Vacant ²⁾ Exposed linear encoders: TTL/11 μA_{PP} conversion for PWT

Interfaces

□ HTL Incremental Signals

HEIDENHAIN encoders with □ HTL interface incorporate electronics that digitize sinusoidal scanning signals with or without interpolation.

The **incremental signals** are transmitted as the square-wave pulse trains U_{a1} and U_{a2} , phase-shifted by 90° elec. The **reference mark signal** consists of one or more reference pulses U_{a0} , which are gated with the incremental signals. In addition, the integrated electronics produce their **inverse signals** $\overline{U_{a1}}$, $\overline{U_{a2}}$ and $\overline{U_{a0}}$ for noise-proof transmission (not with ERN/ROD 1x30). The illustrated sequence of output signals—with U_{a2} lagging U_{a1} —applies for the direction of motion shown in the dimension drawing.

The **fault-detection signal** $\overline{U_{aS}}$ indicates fault conditions such as failure of the light source. It can be used for such purposes as machine shut-off during automated production.

The distance between two successive edges of the incremental signals U_{a1} and U_{a2} through 1-fold, 2-fold or 4-fold evaluation is one **measuring step**.

The subsequent electronics must be designed to detect each edge of the square-wave pulse. The minimum **edge separation a** listed in the *Specifications* refers to a measurement at the output of the given differential input circuitry. To prevent counting error, the subsequent electronics should be designed to process as little as 90% of the edge separation a . The max. permissible **shaft speed** or **traversing velocity** must never be exceeded.

The permissible **cable length** for incremental encoders with HTL signals depends on the scanning frequency, the effective power supply, and the operating temperature of the encoder.

Interface	Square-wave signals □ HTL
Incremental signals	2 HTL square-wave signals U_{a1}, U_{a2} and their inverted signals $\overline{U_{a1}}$, $\overline{U_{a2}}$ (ERN/ROD 1x30 without $\overline{U_{a1}}$, $\overline{U_{a2}}$)
Reference mark signal Pulse width Delay time	One or more HTL square-wave pulses U_{a0} and their inverse pulses $\overline{U_{a0}}$ (ERN/ROD 1x30 without $\overline{U_{a0}}$) 90° elec. (other widths available on request) $ t_d \leq 50$ ns
Fault detection signal Pulse width	One HTL square-wave pulse $\overline{U_{aS}}$ Improper function: LOW Proper function: HIGH $t_S \geq 20$ ms
Signal level	$U_H \geq 21$ V with $-I_H = 20$ mA with supply voltage $U_L \leq 2.8$ V with $I_L = 20$ mA $U_P = 24$ V, without cable
Permissible load	$ I_L \leq 100$ mA max. load per output, (except $\overline{U_{aS}}$) $C_{load} \leq 10$ nF with respect to 0 V Outputs short-circuit proof for max. 1 min. to 0 V and U_P (except $\overline{U_{aS}}$)
Switching times (10% to 90%)	$t_r/t_f \leq 200$ ns (except $\overline{U_{aS}}$) with 1 m cable and recommended input circuitry
Connecting cable Cable length Propagation time	HEIDENHAIN cable with shielding PUR [$4(2 \times 0.14 \text{ mm}^2) + (4 \times 0.5 \text{ mm}^2)$] Max. 300 m (ERN/ROD 1x30 max. 100 m) distributed capacitance 90 pF/m 6 ns/m

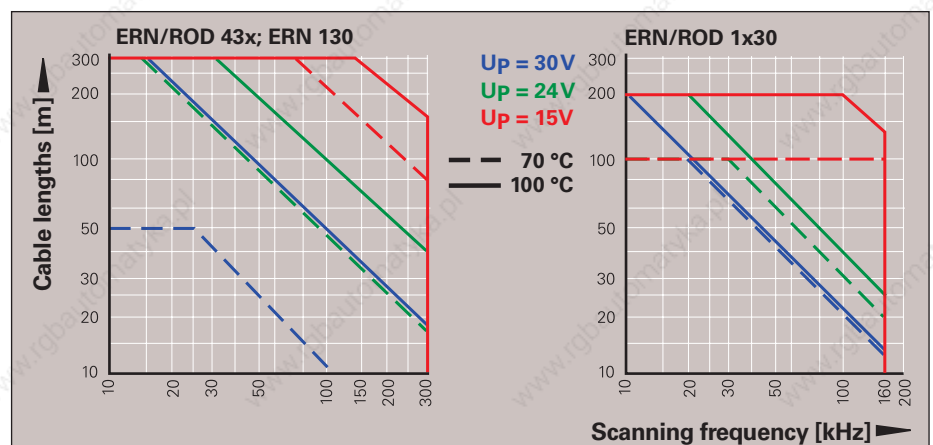
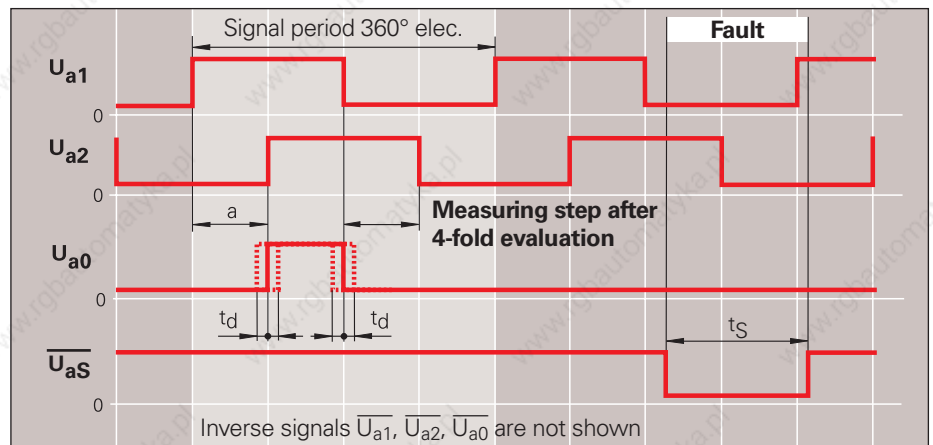

Current consumption

The current consumption for encoders with HTL output signals depends on the output frequency and the cable length to the subsequent electronics. The diagrams at right show typical curves for push-pull signal transmission with a 12-line HEIDENHAIN cable. The maximum current consumption can be 50 mA higher.

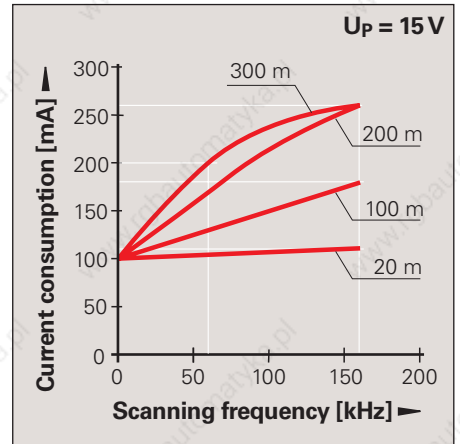
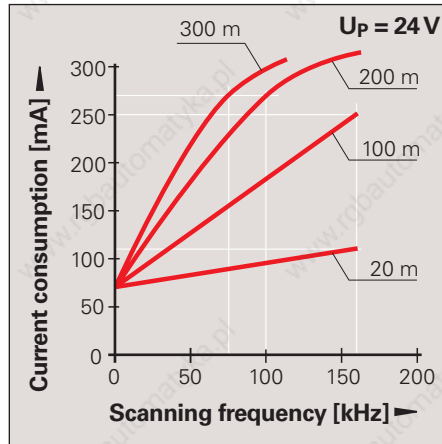

Input circuitry of the subsequent electronics

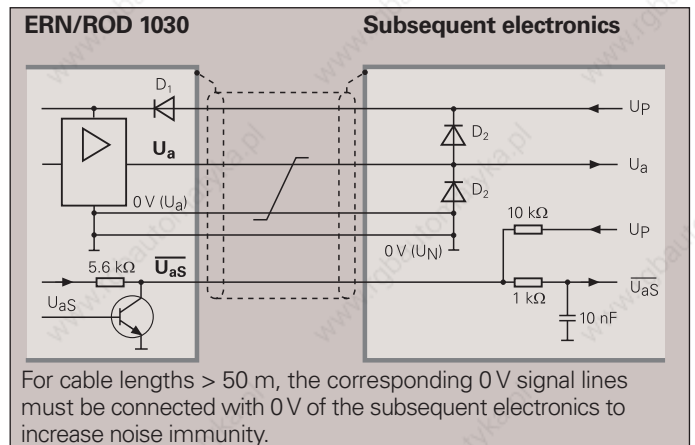
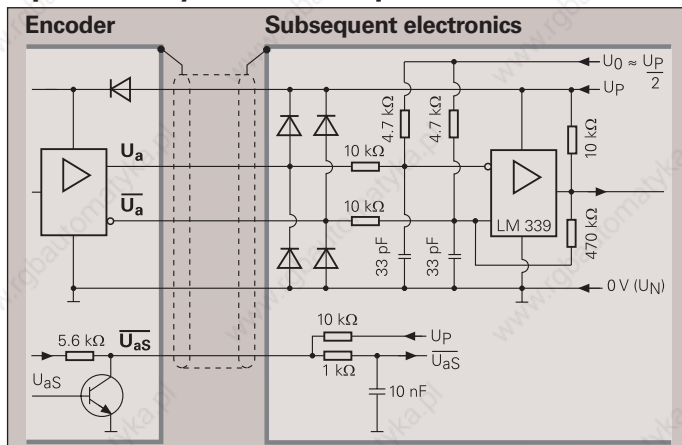

Pin layout

12-pin flange socket or coupling M23					12-pin PCB connector								
Power supply					Incremental signals						Other signals		
	12	2	10	11	5	6	8	1	3	4	7	/	9
	2a	2b	1a	1b	6b	6a	5b	5a	4b	4a	3a	3b	/
	Up	Sensor Up	0 V	Sensor 0 V	Ua1	Ua1-bar	Ua2	Ua2-bar	Ua0	Ua0-bar	UaS-bar	Vacant	Vacant
	Brown/ Green	Blue	White/ Green	White	Brown	Green	Gray	Pink	Red	Black	Violet	/	Yellow

Shield on housing; **Up** = Power supply voltage

Sensor: The sensor line is connected internally with the corresponding power line

ERN 1x30, ROD 1030: 0 V instead of inverse signals Ua1, Ua2, Ua0

Interfaces

EnDat Absolute Position Values

The EnDat interface is a digital, **bidirectional** interface for encoders. It is capable of transmitting **position values** from both absolute and—with EnDat 2.2—incremental encoders, as well as reading and updating information stored in the encoder, or of saving new information. Thanks to the **serial transmission method** only **four signal lines** are required. The data are transmitted **in synchronism** with the clock signal from the subsequent electronics. The type of transmission (position values, parameters, diagnostics, etc.) is selected by mode commands that the subsequent electronics send to the encoder.

Interface	EnDat serial bidirectional
Data transfer	Absolute position values, parameters and additional information
Data input	Differential line receiver according to EIA standard RS 485 for CLOCK, CLOCK, DATA and DATA signals
Data output	Differential line driver according to EIA standard RS 485 for the DATA and DATA signals
Code	Pure binary code
Position values	Ascending in traverse direction indicated by arrow (see Dimensions)
Incremental signals	$\sim 1 V_{PP}$ (see <i>1 V_{PP} Incremental Signals</i>) depending on unit
Connecting cable	HEIDENHAIN cable with shielding
With Incremental signals	PUR [(4 × 0.14 mm ²) + 4(2 × 0.14 mm ²) + (4 × 0.5 mm ²)]
Without signals	PUR [(4 × 0.14 mm ²) + (4 × 0.34 mm ²)]
Cable lengths	Max. 150 m
Propagation time	Max. 10 ns; approx. 6 ns/m

Clock frequency and cable length

Without propagation-delay compensation, the **clock frequency**—depending on the cable length—is variable between **100 kHz** and **2 MHz**. Because large cable lengths and high clock frequencies increase the signal run time to the point that they can disturb the unambiguous assignment of data, the delay can be measured in a test run and then compensated. With this **propagation-delay compensation** in the subsequent electronics, clock frequencies up to **8 MHz** at cable lengths up to a maximum of 100 m are possible. To ensure proper function at clock frequencies above 2 MHz, use only original HEIDENHAIN cables.

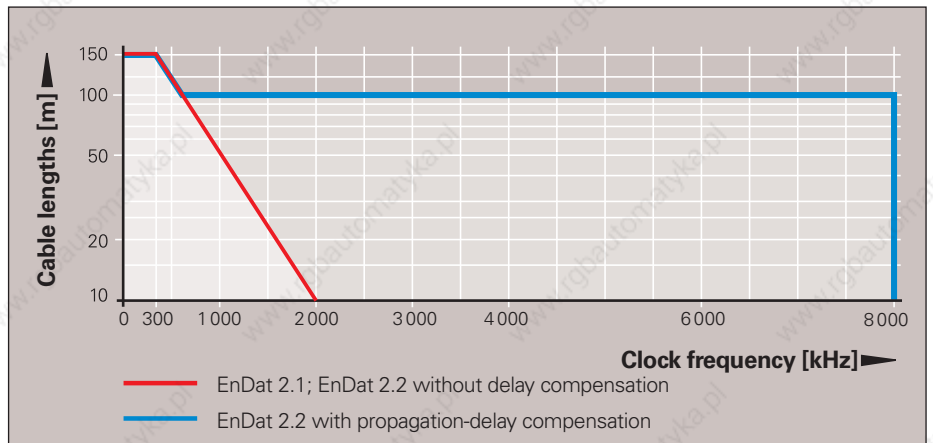

Input circuitry of the subsequent electronics

Dimensioning

IC₁ = RS 485 differential line receiver and driver

$$C_3 = 330 \text{ pF}$$

$$Z_0 = 120 \text{ } \Omega$$

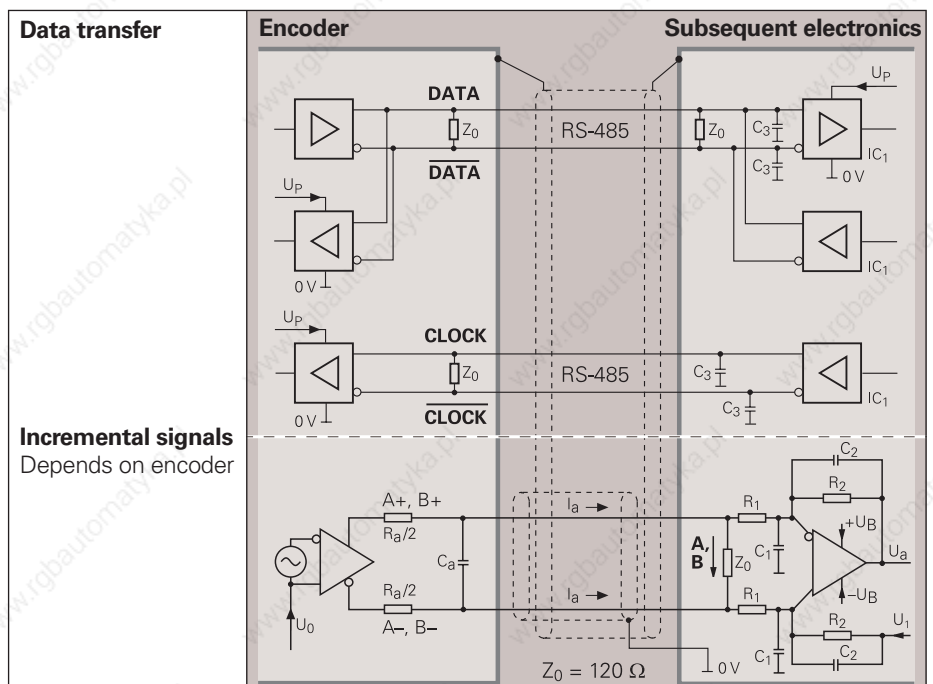

Versions

The extended EnDat interface version 2.2 is compatible in its communication, command set (i.e. the available mode commands) and time conditions with version 2.1, but also offers significant advantages. It makes it possible, for example, to transfer additional information with the position value without sending a separate request for it. The interface protocol was expanded and the time conditions (clock frequency, processing time, recovery time) were optimized.

Both EnDat 2.1 and EnDat 2.2 are available in versions with or without incremental signals. On EnDat 2.2 encoders, the variant without incremental signals is standard due to its high internal resolution. To increase the resolution of EnDat 2.1 encoders, the incremental signals are evaluated in the subsequent electronics.

EnDat 2.2 (includes EnDat 2.1)

- Position values for incremental and absolute encoders
- Additional information on position value
 - Diagnostics and test values
 - Absolute position values after reference run of incremental encoders
 - Parameter upload/download
 - Commutation
 - Acceleration
 - Limit position signal
 - Temperature of the encoder PCB
 - Temperature evaluation of an external temperature sensor (e.g. in the motor winding)

EnDat 2.1

- Absolute position values
- Parameter upload/download
- Reset
- Test command and test values

Interface	Version	Clock frequency	Ordering information
EnDat 2.1	With incremental signals	≤ 2 MHz	EnDat 01
	Without incremental signals		EnDat 21
EnDat 2.2	With incremental signals	≤ 2 MHz	EnDat 02
	Without incremental signals	≤ 8 MHz	EnDat 22

Bold: Standard version

Benefits of the EnDat Interface

- **Automatic self-configuration:** All information required by the subsequent electronics is already stored in the encoder
- **High system security** through alarms and messages for monitoring and diagnosis
- **High transmission reliability** through cyclic redundancy checking
- **Faster configuration during installation:** **Datum shifting** through offsetting by a value in the encoder

Other benefits from EnDat 2.2

- **A single interface** for all absolute and incremental encoders
- **Additional informationen** (limit switch, temperature, acceleration)
- **Quality improvement:** Position value calculation in the encoder permits shorter sampling intervals (25 µs)

Advantages of purely serial

transmission specifically for EnDat 2.2 encoders

- **Simple subsequent electronics** with EnDat receiver chip
- **Simple connection technology:** Standard connecting elements (M12: 8-pin) single shielded standard cable and low wiring costs
- **Minimized transmission times** through adaptation of the data word length to the resolution of the encoder
- **High clock frequencies** up to 8 MHz. Position values available in the subsequent electronics after only approx. 10 µs
- **Support for state-of-the-art machine designs** e.g. direct drive technology

Functions

The EnDat interface transmits absolute position values or additional physical quantities (only EnDat 2.2) in an unambiguous time sequence and serves to read from and write to the encoder's internal memory. Some functions are available only with EnDat 2.2 mode commands.

Position values can be transmitted with or without additional information. The additional information types are selectable via Memory Range Select (MRS) code. Other functions such as parameter reading and writing can also be called after the memory area and address have been selected. Through simultaneous transmission with the position value, axes in the feedback loop can also request additional information and execute functions.

Parameter reading and writing is possible both as a separate function and in connection with the position value. Parameters can be read or written after the memory area and address are selected.

Reset functions serve to reset the encoder in case of malfunction. Reset is possible instead of or during position value transmission.

Servicing diagnosis makes it possible to inspect the position value even at a standstill. A test command has the encoder transmit the required test values.

You can find more information in the *Technical Information for EnDat 2.2* document or on the Internet at www.endat.de.

Selecting the Transmission Type

Transmitted data are distinguished as either position values, position values with additional information, or parameters. The type of information to be transmitted is selected by mode commands. **Mode commands** define the content of the transmitted information. Every mode command consists of three bits. To ensure reliable transmission, every bit is transmitted redundantly (inverted or double). If the encoder detects an erroneous mode transmission, it transmits an error message. The EnDat 2.2 interface can also transfer parameter values in the additional information together with the position value. This makes the current position values constantly available for the control loop, even during a parameter request.

Control Cycles for Transfer of Position Values

The transmission cycle begins with the first falling **clock edge**. The measured values are saved and the position value calculated. After two clock pulses (2T), to **select the type of transmission** the subsequent electronics transmit the mode command *Encoder transmit position value* (with/without additional information).

After successful calculation of the absolute position value (t_{cal} —see table), the **start bit** begins the data transmission from the encoder to the subsequent electronics. The subsequent **error messages**, error 1 and error 2 (only with EnDat 2.2 commands), are group signals for all monitored functions and serve for failure monitoring.

Beginning with the LSB, the encoder then transmits the absolute **position value** as a complete data word. Its length depends on the encoder being used. The number of required clock pulses for transmission of a position value is saved in the parameters of the encoder manufacturer. The data transmission of the position value is completed with the **Cyclic Redundancy Check** (CRC).

In EnDat 2.2, this is followed by the additional information 1 and 2, each also concluded with a CRC. With the end of the data word, the clock must be set to HIGH. After 10 to 30 μs or 1.25 to 3.75 μs (with EnDat 2.2 parameterizable recovery time t_m) the data line falls back to LOW. Then a **new data transmission** can begin by starting the clock.

Mode commands

<ul style="list-style-type: none"> Encoder transmit position values Selection of the memory area Encoder receive parameters Encoder transmit parameters Encoder receive reset¹⁾ Encoder transmit test values Encoder receive test commands 	EnDat 2.1	EnDat 2.2
<ul style="list-style-type: none"> Encoder transmit position value with additional information Encoder transmit position value and receive selection of memory area²⁾ Encoder transmit position value and receive parameters²⁾ Encoder transmit position value and transmit parameters²⁾ Encoder transmit position value and receive error reset²⁾ Encoder transmit position value and receive test command²⁾ Encoder receive communication command³⁾ 		

¹⁾ Same reaction as switching the power supply off and on

²⁾ Selected additional information is also transmitted

³⁾ Reserved for encoders that do not support the safety system

		Without delay compensation	With delay compensation
Clock frequency	f_c	100 kHz ... 2 MHz	100 kHz ... 8 MHz
Calculation time for Position value Parameters	t_{cal} t_{ac}	See <i>Specifications</i> Max. 12 ms	
Recovery time	t_m	<i>EnDat 2.1</i> : 10 to 30 μs <i>EnDat 2.2</i> : 10 to 30 μs or 1.25 to 3.75 μs ($f_c \geq 1$ MHz) (parameterizable)	
	t_R	Max. 500 ns	
	t_{ST}	–	2 to 10 μs
Data delay time	t_D	(0.2 + 0.01 x cable length in m) μs	
Pulse width	t_{HI}	0.2 to 10 μs	Pulse width fluctuation HIGH to LOW max. 10%
	t_{LO}	0.2 to 50 ms/30 μs (with LC)	

EnDat 2.2 – Transfer of Position Values

EnDat 2.2 can transmit position values selectably with or without additional information.

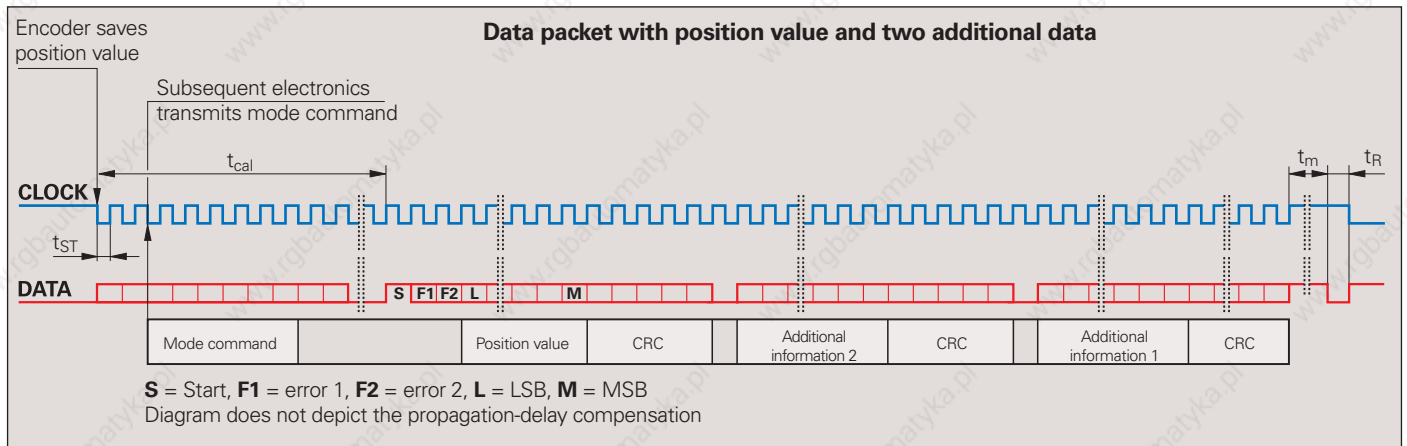
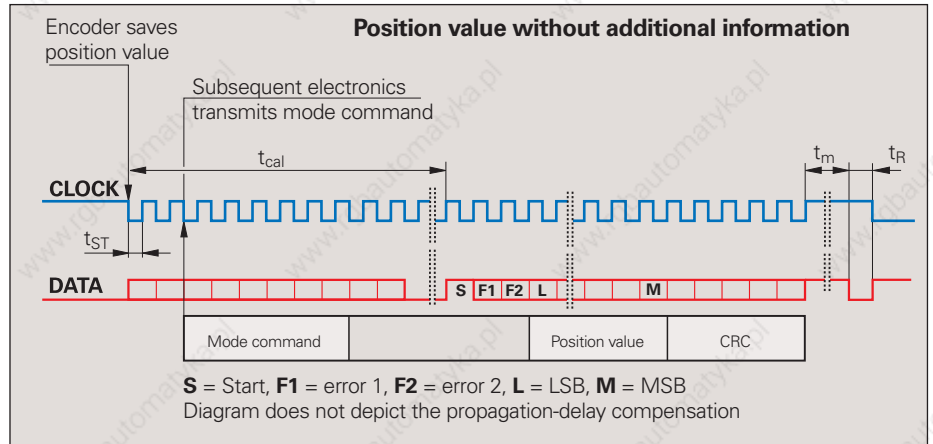

Additional information

With EnDat 2.2, one or two additional data can be appended to the position value. The additional data are each 30 bits in length with LOW as first bit, and end with a CRC check. The additional information supported by the respective encoder is saved in the encoder parameters.

The content of the additional information is determined by the MRS code and is transmitted in the next sampling cycle for additional information. This information is then transmitted with every sampling until a selection of a new memory area changes the content.

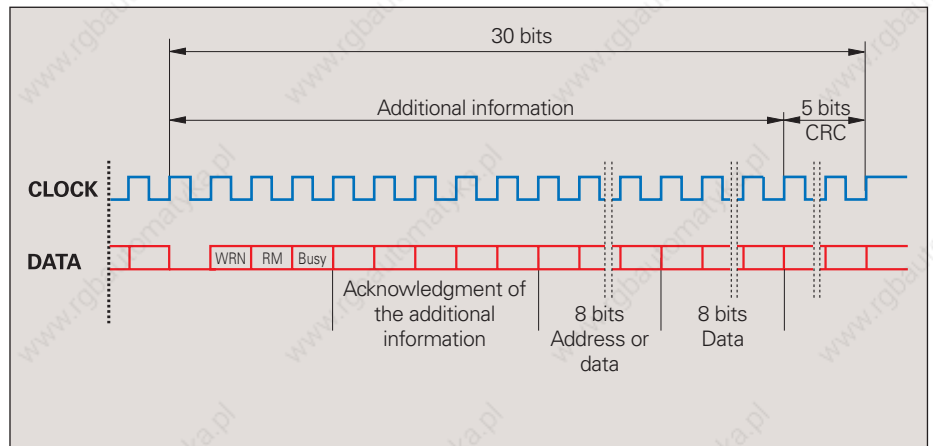

The additional data always begin with:

Status data
Warning—WRN
Reference mark—RM
Parameter request—busy
Acknowledgment of additional information

The additional data can contain the following information:

Additional information 1
Diagnosis
Position value 2
Memory parameters
MRS-code acknowledgment
Test values
Temperature

Additional information 2
Commutation
Acceleration
Limit position signals

EnDat 2.1 – Transfer of Position Values

EnDat 2.1 can transmit position values selectively with interrupted clock pulse (as in EnDat 2.2) or continuous clock pulse.

Interrupted clock

The interrupted clock is intended particularly for time-clocked systems such as closed control loops. At the end of the data word the clock signal is set to HIGH level. After 10 to 30 μs (t_m), the data line falls back to LOW. Then a new data transmission can begin by starting the clock.

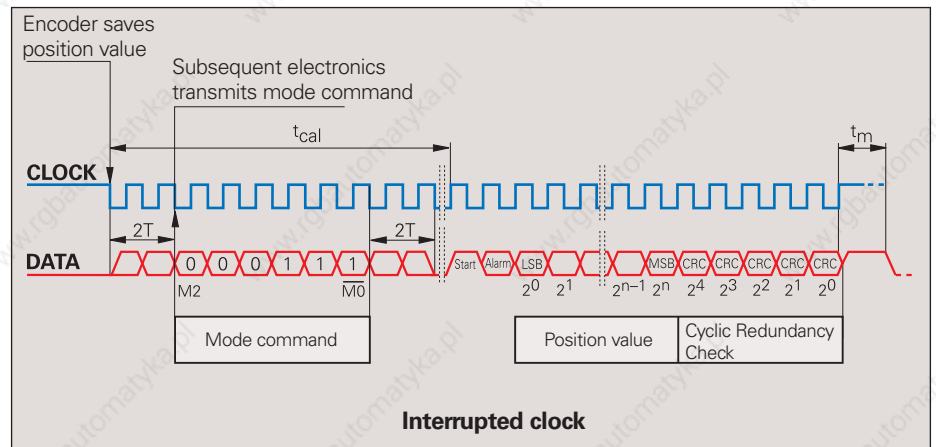

Continuous clock

For applications that require fast acquisition of the measured value, the EnDat interface can have the clock run continuously. Immediately after the last CRC bit has been sent, the data line is switched to high for one clock cycle, and then to low. The new position value is saved with the very next falling edge of the clock and is output in synchronism with the clock signal immediately after the start bit and alarm bit. Because the mode command *Encoder transmits position value* is needed only before the first data transmission, the continuous-clock transfer mode reduces the length of the clock-pulse group by 10 periods per position value.

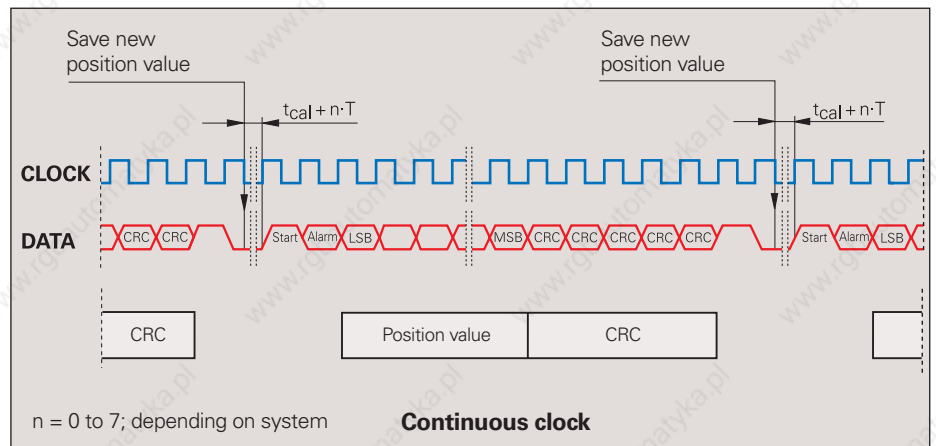

Synchronization of the serially transmitted code value with the incremental signal

Absolute encoders with EnDat interface can exactly synchronize serially transmitted absolute position values with incremental values. With the first falling edge (latch signal) of the CLOCK signal from the subsequent electronics, the scanning signals of the individual tracks in the encoder and counter are frozen, as are also the A/D converters for subdividing the sinusoidal incremental signals in the subsequent electronics.

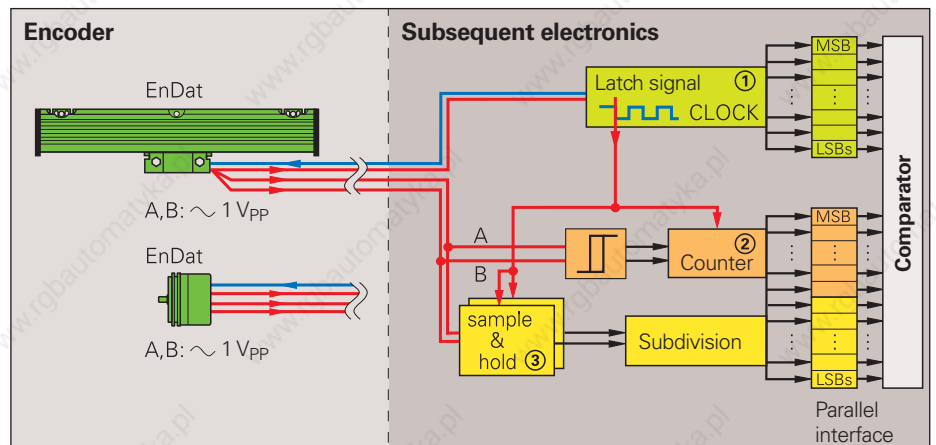

The code value transmitted over the serial interface unambiguously identifies one incremental signal period. The position value is absolute within one sinusoidal period of the incremental signal. The subdivided incremental signal can therefore be appended in the subsequent electronics to the serially transmitted code value.

After power on and initial transmission of position values, two redundant position values are available in the subsequent electronics. Since encoders with EnDat interface guarantee a precise synchronization—regardless of cable length—of the serially transmitted absolute value with the incremental signals, the two

values can be compared in the subsequent electronics. This monitoring is possible even at high shaft speeds thanks to the EnDat interface's short transmission times of less than 50 μs . This capability is a prerequisite for modern machine design and safety techniques.

Parameters and Memory Areas

The encoder provides several memory areas for parameters. These can be read from by the subsequent electronics, and some can be written to by the encoder manufacturer, the OEM, or even the end user. Certain memory areas can be write-protected.

 The parameters, which in most cases are set by the OEM, largely define the function of the encoder and the EnDat interface. When the encoder is exchanged, it is therefore essential that its parameter settings are correct. Attempts to configure machines without including OEM data can result in malfunctions. If there is any doubt as to the correct parameter settings, the OEM should be consulted.

Parameters of the encoder manufacturer

This write-protected memory area contains all **information specific to the encoder**, such as encoder type (linear/angular, singleturn/multiturn, etc.), signal periods, position values per revolution, transmission format of position values, direction of rotation, maximum speed, accuracy dependent on shaft speeds, support of warnings and alarms, part number and serial number. This information forms the basis for **automatic configuration**. A separate memory area contains the parameters typical for EnDat 2.2: Status of additional information, temperature, acceleration, support of diagnostic and error messages, etc.

Parameters of the OEM

In this freely definable memory area, the OEM can store his information, e.g. the “electronic ID label” of the motor in which the encoder is integrated, indicating the motor model, maximum current rating, etc.

Operating parameters

This area is available for a **datum shift** and the configuration of diagnostics. It can be protected against overwriting.

Operating status

This memory area provides detailed alarms or warnings for diagnostic purposes. Here it is also possible to activate write protection for the OEM parameter and operating parameter memory areas and interrogate their status. Once **write protection** is activated, it cannot be removed.

Safety System

The safety system is in preparation. Safety-oriented controls are the planned application for encoders with EnDat 2.2 interface. Refer to the EN 61800 standard *Adjustable speed electrical power drive systems* Part 5-2.

Monitoring and Diagnostic Functions

The EnDat interface enables comprehensive monitoring of the encoder without requiring an additional transmission line. The alarms and warnings supported by the respective encoder are saved in the “parameters of the encoder manufacturer” memory area.

Diagnosis

Cyclic information on encoder function and additional diagnostic values are transmitted in the additional information.

Error message

An error message becomes active if a **malfunction of the encoder** might result in incorrect position values. The exact cause of the trouble is saved in the encoder’s “operating status” memory where it can be interrogated in detail. Errors include, for example,

- Light unit failure
- Signal amplitude too low
- Error in calculation of position value
- Power supply too high/low
- Current consumption is excessive

Here the EnDat interface transmits the error bits, error 1 and error 2 (only with EnDat 2.2 commands). These are group signals for all monitored functions and serve for failure monitoring. The two error messages are generated independently from each other.

Warning

This collective bit is transmitted in the status data of the additional information. It indicates that certain **tolerance limits of the encoder** have been reached or exceeded—such as shaft speed or the limit of light source intensity compensation through voltage regulation—without implying that the measured position values are incorrect. This function makes it possible to issue preventive warnings in order to minimize idle time.

Cyclic Redundancy Check

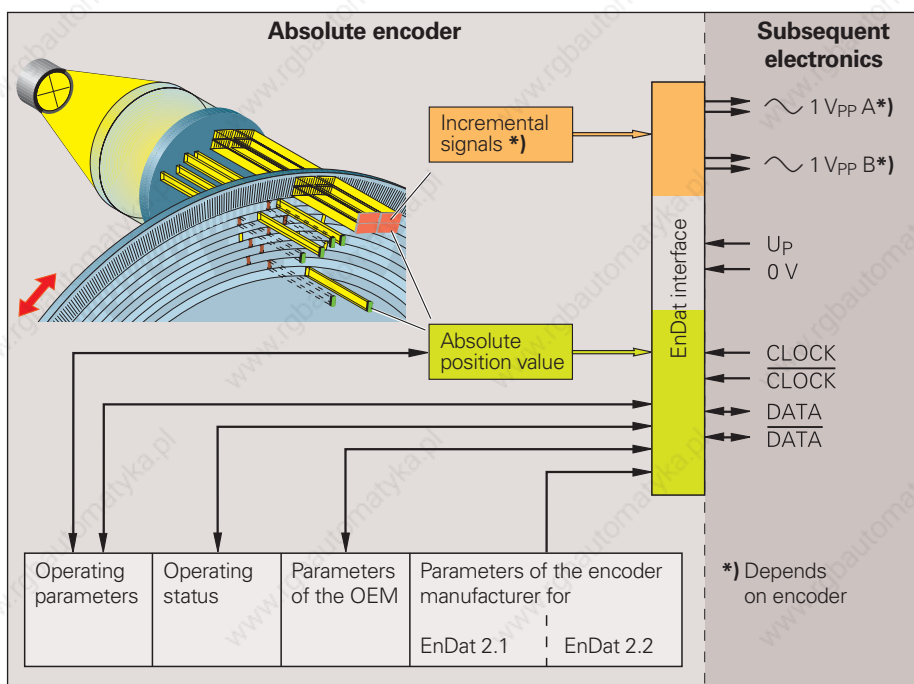

To ensure **reliability of data transfer**, a cyclic redundancy check (CRC) is performed through the logical processing of the individual bit values of a data word. This 5-bit long CRC concludes every transmission. The CRC is decoded in the receiver electronics and compared with the data word. This largely eliminates errors caused by disturbances during data transfer.



Pin Layout

17-pin coupling M23



	Power supply					Incremental signals ¹⁾				Absolute position values			
	7	1	10	4	11	15	16	12	13	14	17	8	9
	U_P	Sensor U _P	0V	Sensor 0V	Inside shield	A+	A-	B+	B-	DATA	DATA	CLOCK	CLOCK
	Brown/ Green	Blue	White/ Green	White	/	Green/ Black	Yellow/ Black	Blue/ Black	Red/ Black	Gray	Pink	Violet	Yellow

Shield on housing; **U_P** = Power supply voltage



Sensor: The sensor line is connected internally with the corresponding power line

Vacant pins or wires must not be used!

¹⁾ Not with EnDat 2.2, order information 22

8-pin coupling M12





	Power supply					Absolute position values			
	2	8	1	5	3	4	7	6	
	U_P ¹⁾	U_P	0V ¹⁾	0V	DATA	DATA	CLOCK	CLOCK	
	Blue	Brown/Green	White	White/Green	Gray	Pink	Violet	Yellow	

Shield on housing; **U_P** = Power supply voltage

¹⁾ for power lines configured parallel

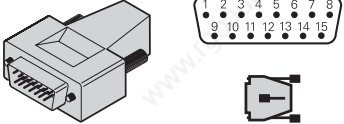
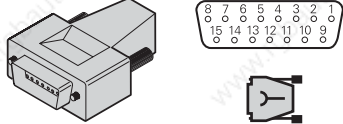
Vacant pins or wires must not be used!

15-pin D-sub connector (male) for IK 115/IK 215						15-pin D-sub connector, female for HEIDENHAIN controls and IK 220							
	Power supply					Incremental signals ¹⁾				Absolute position values			
	4	12	2	10	6	1	9	3	11	5	13	8	15
	1	9	2	11	13	3	4	6	7	5	8	14	15
	U_P	Sensor U _P	0V	Sensor 0V	Inside shield	A+	A-	B+	B-	DATA	DATA	CLOCK	CLOCK
	Brown/ Green	Blue	White/ Green	White	/	Green/ Black	Yellow/ Black	Blue/ Black	Red/ Black	Gray	Pink	Violet	Yellow

Shield on housing; **U_P** = Power supply voltage

Sensor: The sensor line is connected internally with the corresponding power line

Vacant pins or wires must not be used!

¹⁾ Not with EnDat 2.2, order information 22

Interface

PROFIBUS-DP Absolute Position Values

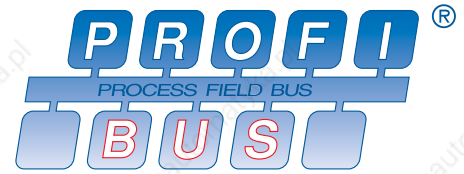

PROFIBUS-DP

PROFIBUS is a nonproprietary, open field bus in accordance with the international EN 50170 standard. The connecting of sensors through field bus systems minimizes the cost of cabling and the number of lines between encoder and subsequent electronics.

Topology and bus assignment

The PROFIBUS-DP is designed as a linear structure. It permits transfer rates up to 12 Mbit/s. Both mono-master and multi-master systems are possible. Each master can serve only its own slaves (polling). The slaves are polled cyclically by the master. Slaves are, for example, sensors such as absolute rotary encoders, linear encoders, or also control devices such as motor frequency inverters.

Physical characteristics

The electrical features of the PROFIBUS-DP comply with the RS-485 standard. The bus connection is a shielded, twisted two-wire cable with active bus terminals at each end.

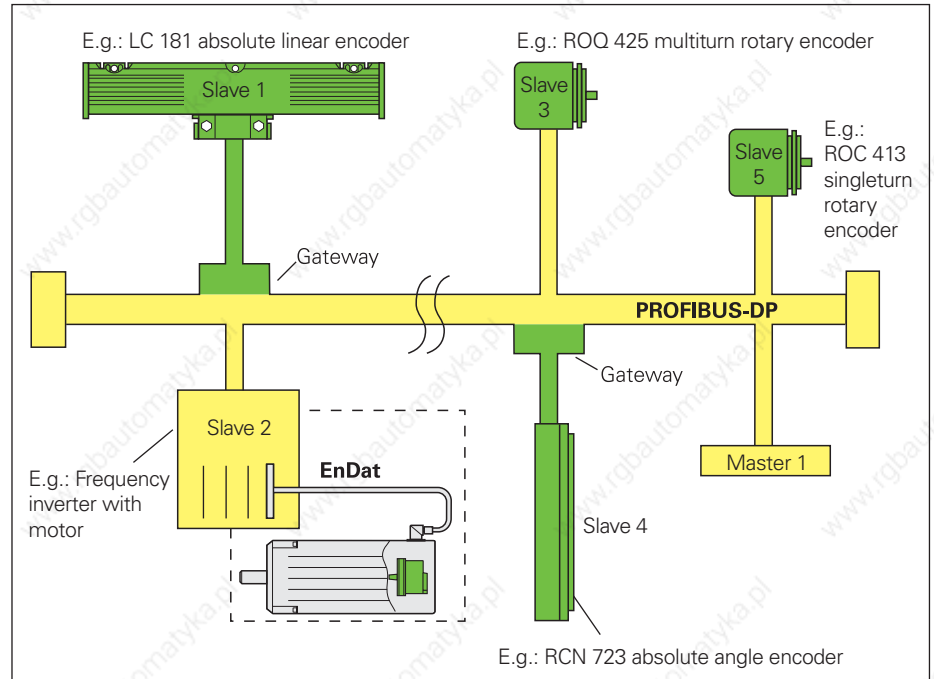

Bus structure of PROFIBUS-DP

Self-configuration

The characteristics of the HEIDENHAIN encoders required for system configuration are included as "electronic data sheets"—also called device identification records (GSD)—in the gateway. These device identification records hold the complete and exact characteristics of a device in a precisely defined format, which permits the simple and application-friendly integration of the devices into the bus system.

Configuration

PROFIBUS-DP devices can be configured and the parameters assigned to fit the requirements of the user. Once these settings are made in the configuration tool with the aid of the GSD file, they are saved in the master. It then configures the PROFIBUS devices every time the network starts up. This simplifies exchanging the devices: there is no need to edit or reenter the configuration data.

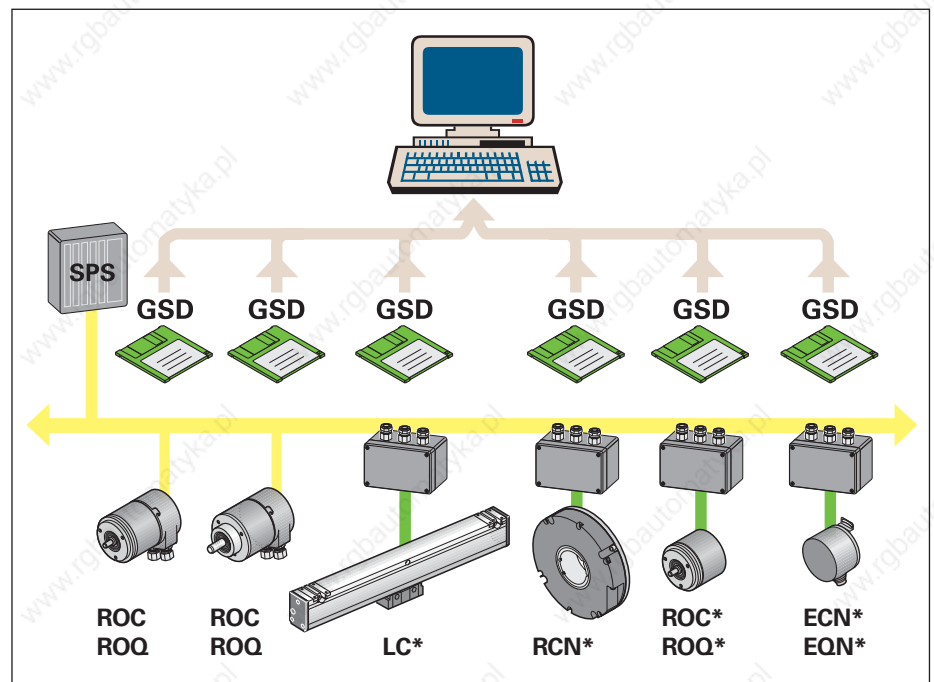

* with EnDat interface

PROFIBUS-DP profile

The PNO (PROFIBUS user organization) has defined a standard, nonproprietary profile for the connection of absolute encoders to the PROFIBUS-DP, thus ensuring high flexibility and simple configuration on all systems that use this standardized profile.

You can request the profile for absolute encoders from the PNO in Karlsruhe, Germany, under the order number 3.062. There are two classes defined in the profile, whereby class 1 provides minimum support, and class 2 allows additional, in part optional functions.

Supported functions

Particularly important in decentralized field bus systems are the **diagnostic functions** (e.g. warnings and alarms), and the **electronic ID label** with information on the type of encoder, resolution, and measuring range. But also programming functions such as counting direction reversal, **preset/datum shift** and **changing the resolution (scaling)** are possible. The **operating time** of the encoder can also be recorded.

Operating status

In addition to the transfer of the diagnostic functions over the PROFIBUS-DP, the operating statuses of the

- power supply and
- bus status

are displayed by LEDs on the rear of the encoder.

Characteristic	Class	ECN 113 ¹⁾ ECN 413 ¹⁾ ROC 413	EQN 425 ¹⁾ ROQ 425	ROC 415 ¹⁾ ROC 417 ¹⁾	LC 481 ¹⁾ LC 182 ¹⁾
Position value in pure binary code	1, 2	✓	✓	✓	✓
Data word length	1, 2	16	32	32	32
Scaling function	Measuring step/rev	2	✓	✓ ²⁾	–
	Total resolution	2	✓	–	–
Reversal of counting direction	1, 2	✓	✓	✓	–
Preset/Datum shift	2	✓	✓	✓	–
Diagnostic functions	Warnings and alarms	2	✓	✓	✓
Operating time recording	2	✓	✓	✓	✓
Profile version	2	✓	✓	✓	✓
Serial number	2	✓	✓	✓	✓



Connection

The absolute rotary encoders with **integrated PROFIBUS-DP interface** feature screw terminals for the PROFIBUS-DP and the power supply. The cable is connected over three PG7 screw connections on the bus housing. Here the coding switches are located for addressing (0 to 99) and selecting the terminating resistor, which is to be activated if the rotary encoder is the last participant on the PROFIBUS-DP. All connections and controls are easily accessible in the bus housing.

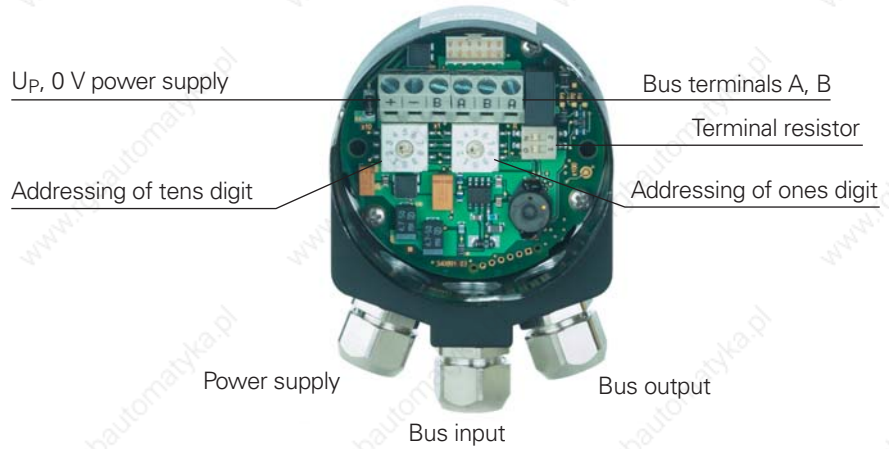

Connection via gateway

All absolute encoders from HEIDENHAIN with **EnDat interface** are suitable for PROFIBUS-DP. The encoder is electrically connected through a **gateway**. The complete interface electronics are integrated in the gateway, which offers a number of benefits:

- Simple connection of the field bus cable, since the terminals are easily accessible.
- Encoder dimensions remain small.
- No temperature restrictions for the encoder. All temperature-sensitive components are in the gateway.
- No bus interruption when an encoder is exchanged.

Besides the EnDat encoder connector, the gateway provides connections for the PROFIBUS and the power supply. In the gateway there are coding switches for addressing and selecting the terminating resistor.

Since the gateway is connected directly to the bus lines, the cable to the encoder is not a stub line, although it can be up to 150 meters long.

	Gateway
Power supply	10 to 30 V/max. 400 mA (internal voltage converter to $5\text{ V} \pm 5\%$ for EnDat encoders)
Protection	IP 67
Operating temperature	$-40\text{ }^{\circ}\text{C}$ to $80\text{ }^{\circ}\text{C}$
Electrical connection	Flange socket 17-pin Terminals, PG9 cable exit
EnDat PROFIBUS-DP	
Id. Nr.	325771-01

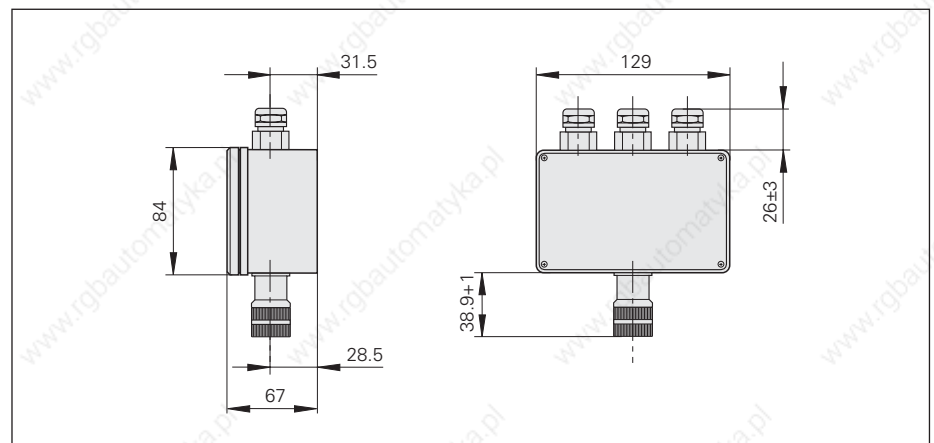

Interfaces

SSI Absolute Position Values

The **absolute position value**, beginning with the Most Significant Bit, is transferred over the data lines (DATA) in synchronism with a CLOCK signal from the control. The SSI standard data word length for single-turn absolute encoders is 13 bits, and for multiturn absolute encoders 25 bits. In addition to the absolute position values, sinusoidal **incremental signals** with $1-V_{PP}$ levels are transmitted. For a description of the signals, see *1 V_{PP} Incremental Signals*.

The following **functions** can be activated via the interface by applying the supply voltage U_P :

- **Direction of rotation**

Continuous application of the supply voltage U_P to pin 2 reverses the direction of rotation for ascending position values.
 Pin 2 inactive: Ascending position values with clockwise rotation
 Pin 2 active: Ascending position values with counterclockwise rotation

- **Reset**

Brief application of the supply voltage U_P to pin 5 ($t_{min} > 1$ ms) sets the current position to zero.

Interface	SSI serial
Data transfer	Absolute position values
Data input	Differential line receiver according to EIA standard RS 485 for the CLOCK and CLOCK signals
Data output	Differential line driver according to EIA standard RS 485 for the DATA and DATA signals
Code	Gray code
Ascending position values	With clockwise rotation viewed from flange side (can be switched via interface)
Incremental signals	$\sim 1 V_{PP}$ (see <i>1 V_{PP} Incremental Signals</i>)
Programming inputs	Direction of rotation and reset
Inactive	LOW $< 0.25 \times U_P$ or input open
Active	HIGH $> 0.6 \times U_P$
Switching time	$t_{min} > 1$ ms
Connecting cable	HEIDENHAIN cable with shielding PUR [(4 x 0.14 mm ²) + 4(2 x 0.14 mm ²) + (4 x 0.5 mm ²)]
Cable lengths	Max. 150 m distributed capacitance 90 pF/m
Propagation time	6 ns/m

Control cycle for complete data word

When not transmitting, the clock and data lines are on high level. The current position value is stored on the first falling edge of the clock. The stored data is then clocked out on the first rising edge.

After transmission of a complete data word, the data line remains low for a period of time (t_2) until the encoder is ready for interrogation of a new value. If a falling clock edge is received within t_2 , the same data will be output once again.

If the data output is interrupted (CLOCK = high for $t \geq t_2$), a new position value will be stored on the next falling edge of the clock, and on the subsequent rising edge clocked out to the subsequent electronics.

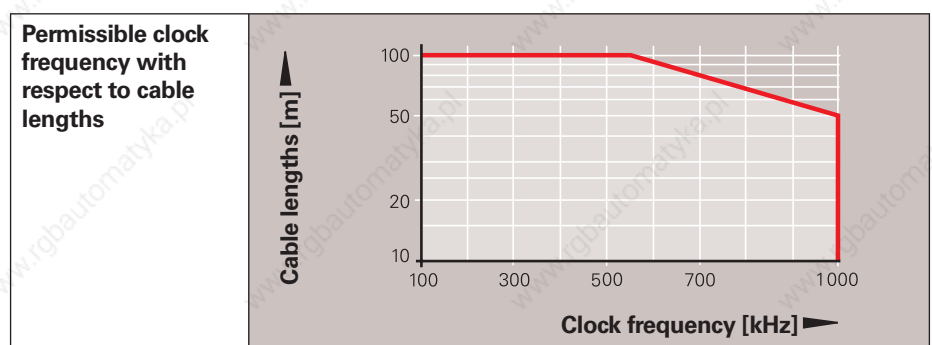
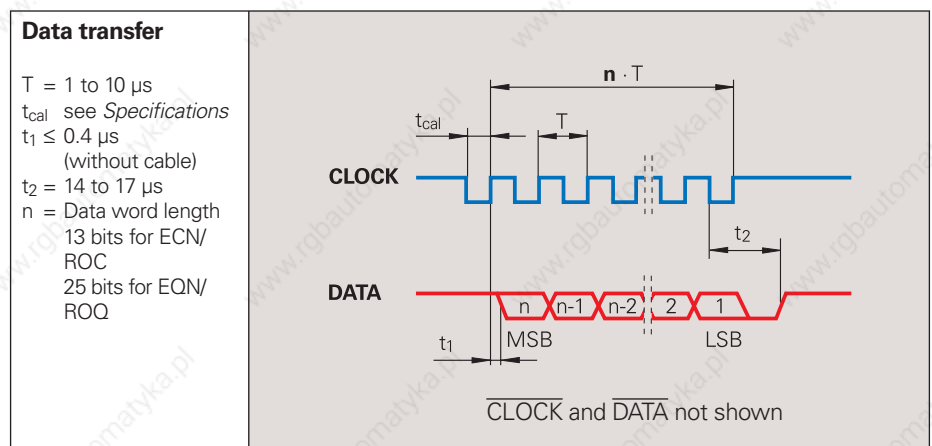

Input circuitry of the subsequent electronics

Dimensioning

IC₁ = Differential line receiver and driver
 E.g. SN 65 LBC 176
 LT 485

Z₀ = 120 Ω

C₃ = 330 pF (serves to improve noise immunity)

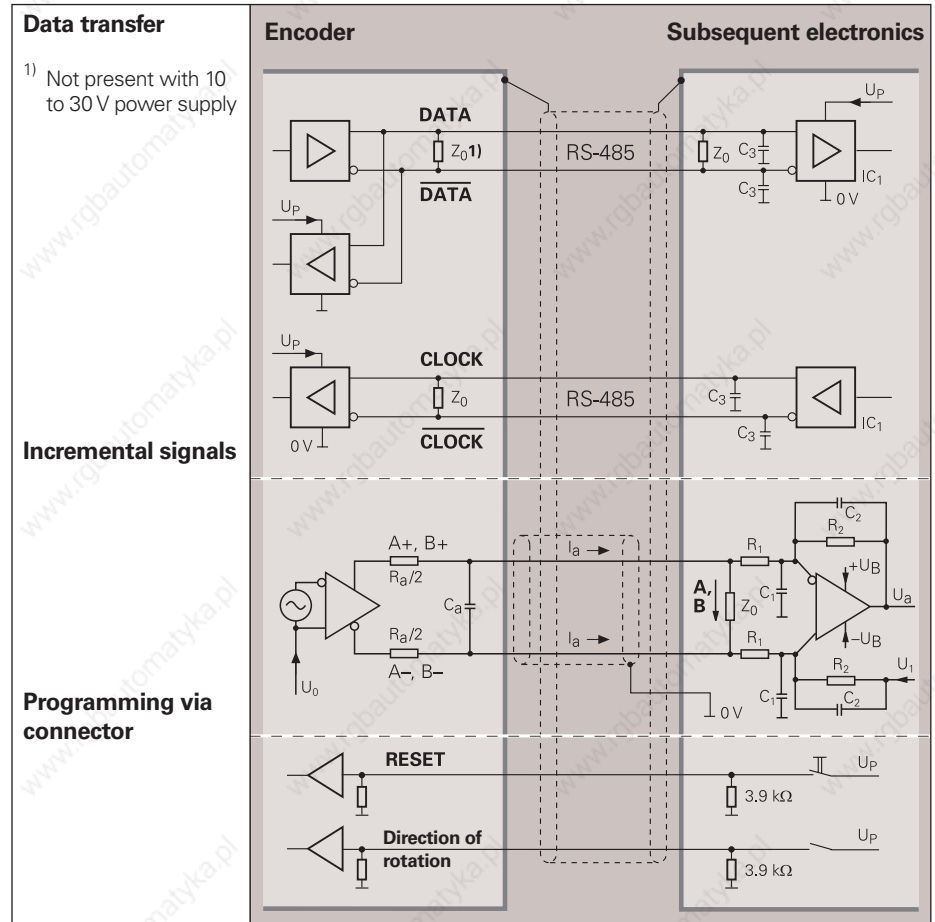

Pin layout

17-pin coupling M23																
Power supply					Incremental signals					Absolute position values				Other signals		
7	1	10	4	11	15	16	12	13	14	17	8	9	2	5		
U _P	Sensor U _P	0V	Sensor 0V	Inside shield	A+	A-	B+	B-	DATA	DATA	CLOCK	CLOCK	Direction of rotation	Reset		
Brown/ Green	Blue	White/ Green	White	/	Green/ Black	Yellow/ Black	Blue/ Black	Red/ Black	Gray	Pink	Violet	Yellow	Black	Green		

Shield on housing; **U_P** = Power supply voltage

Sensor: With a 5 V supply voltage, the sensor line is connected internally with the corresponding power line.

Vacant pins or wires must not be used!

HEIDENHAIN Measuring Equipment and Counter Cards

The **IK 215** is an adapter card for PCs for inspecting and testing absolute HEIDENHAIN encoders with EnDat or SSI interface. All parameters can be read and written via the EnDat interface.



IK 215	
Encoder input	EnDat (absolute value or incremental signals) or SSI
Interface	PCI bus, Rev. 2.1
Application software	Operating system: Windows 2000/XP (Windows 98 in development) Functions: Position value display Counter for incremental signals EnDat functions
Signal subdivision for incremental signals	Up to 1024-fold
Dimensions	100 mm x 190 mm

The **PWM 9** is a universal measuring device for checking and adjusting HEIDENHAIN incremental encoders. There are different expansion modules available for checking the different encoder signals. The values can be read on an LCD monitor. Soft keys provide ease of operation.



PWM 9	
Inputs	Expansion modules (interface boards) for 11 μ App; 1 Vpp; TTL; HTL; EnDat*/SSI*/commutation signals *No display of position values or parameters
Features	<ul style="list-style-type: none"> • Measurement of signal amplitudes, current consumption, operating voltage, scanning frequency • Graphic display of incremental signals (amplitudes, phase angle and on-off ratio) and the length and width of the reference signal • Display symbols for the reference mark, fault detection signal, counting direction • Universal counter, interpolation selectable from single to 1024-fold • Adjustment support for exposed linear encoders
Outputs	<ul style="list-style-type: none"> • Inputs are connected through to the subsequent electronics • BNC sockets for connection to an oscilloscope
Power Supply	10 to 30 V, max. 15 W
Dimensions	150 mm x 205 mm x 96 mm

The **IK 220** is an expansion board for AT-compatible PCs for recording the measured values of **two incremental or absolute linear or angle encoders**. The subdivision and counting electronics **subdivide the sinusoidal input signals up to 4096-fold**. A driver software package is included in delivery.



IK 220				
Input signals (switchable)	\sim 1 Vpp	\sim 11 μ App	EnDat	SSI
Encoder inputs	Two D-sub connectors (15-pin), male			
Input frequency (max.)	500 kHz	33 kHz	-	
Cable lengths (max.)	60 m		10 m	
Interface	PCI bus (plug and play)			
Driver software and demonstration program	for WINDOWS 95/98/NT/2000/XP in VISUAL C++, VISUAL BASIC and BORLAND DELPHI			
Dimensions	Approx. 190 mm x 100 mm			

For more information, ask for our product information sheet *IK 220*.

Connecting Elements and Cables

General Information

Connector insulated: Connecting element with coupling ring, available with male or female contacts.

Symbols  

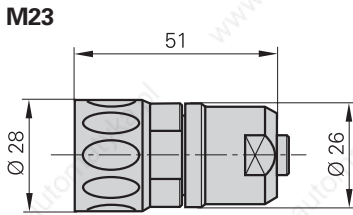

Flange socket: Permanently mounted on the encoder or a housing, with external thread (like the coupling), and available with male or female contacts.

Symbols  

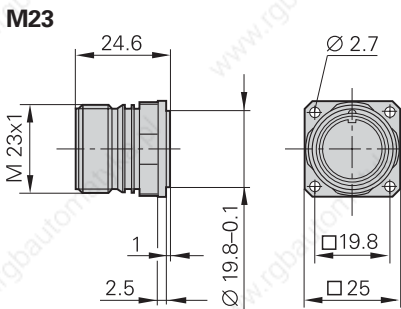

D-sub connector: For HEIDENHAIN controls, counters and IK absolute value cards.

Symbols  

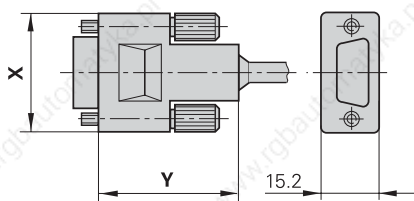

x: 42.7 y: 41.7

Coupling insulated: Connecting element with external thread; Available with male or female contacts.

Symbols  

Mounted coupling with central fastening

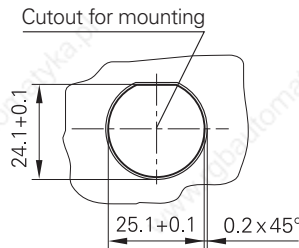

Mounted coupling with flange

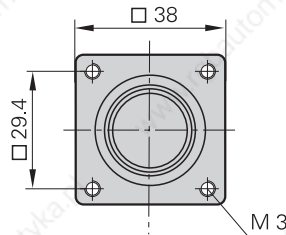

M23

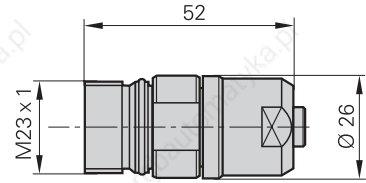

M23

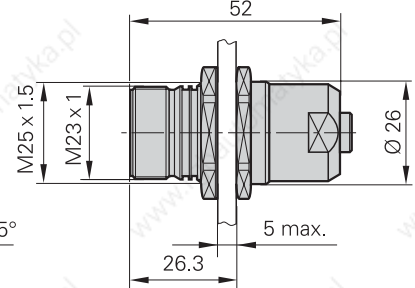

M23

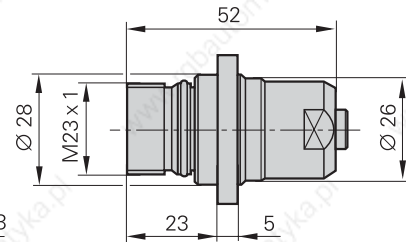

Right-angle flange socket (rotatable) on adapter cable inside the motor with connection for temperature sensor

M23

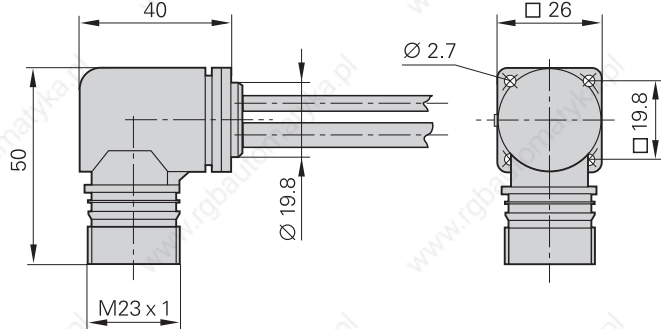

Accessory for flange socket and mounted couplings M23

Bell seal

Id. Nr. 266526-01

Threaded metal dust cap

Id. Nr. 219926-01

The pins on connectors are **numbered** in the direction opposite to those on couplings or flange socket, regardless of whether the contacts are

male or



female.















When engaged, the connections provide **protection** to IP 67 (D-sub connector: IP 50; EN 60529). When not engaged, there is no protection.



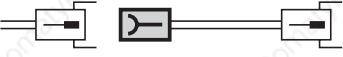
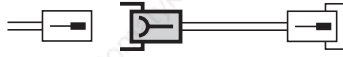
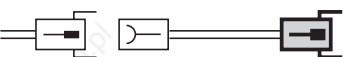
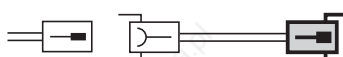
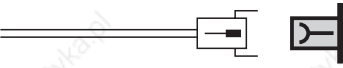

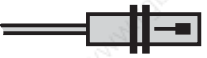
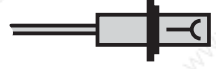
Connecting Cables $\sim 1 V_{PP}$



TTL



HTL



PUR M23 connecting cable $\varnothing 8$ mm [4(2 × 0.14 mm ²) + (4 × 0.5 mm ²)]			
For encoders with connector		For encoders with coupling or flange socket	
Complete with coupling (female) and connector (male) 	298400-xx	Complete with connector (female) and connector (male) 	298399-xx
With one coupling (female) 	298402-xx	Complete with connector (female) and D-sub connector (female) for IK 220 	310199-xx
Cable only PUR $\varnothing 8$ mm 	244957-01	With one connector (female) 	309777-xx
Connectors and couplings M23			
Connector on encoder cable 	Connector (male), 12-pin	Coupling on encoder cable 	Coupling (male), 12-pin
For cable $\varnothing 6$ mm $\varnothing 4.5$ mm	291697-07 291697-06	For cable $\varnothing 6$ mm $\varnothing 4.5$ mm	291698-03 291698-14
Mating element for encoder connector 	Coupling (female), 12-pin	Mating element for encoder coupling or flange socket 	Connector (female), 12-pin
For connecting cable $\varnothing 8$ mm	291698-02	For connecting cable $\varnothing 8$ mm	291697-05
Connector for connection to subsequent electronics 	Connector (male), 12-pin	Connector for connection to subsequent electronics 	Connector (male), 12-pin
For connecting cable $\varnothing 8$ mm	291697-08	For connecting cable $\varnothing 8$ mm	291697-08
Couplings and flange socket M23 for mounting			
	Flange socket (female), 12-pin		Mounted coupling with flange (male), 12-pin
	200722-01	For cable ~ 6 mm $\varnothing 8$ mm	291698-08 291698-31
	Mounted coupling with central fastening (male), 12-pin		Mounted coupling with flange (female), 12-pin
For cable $\varnothing 6$ mm	291698-33	For cable $\varnothing 6$ mm $\varnothing 8$ mm	291698-17 291698-07
Adapter connector $\sim 1 V_{PP}/\sim 11 \mu A_{PP}$			
For converting the 1- V_{PP} output signals to 11- μA_{PP} input signals for the subsequent electronics; connector (female) 12-pin and connector (male) 9-pin			
			364914-01

Connecting Cables EnDat SSI

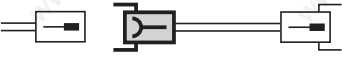
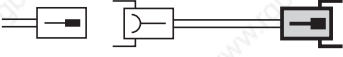
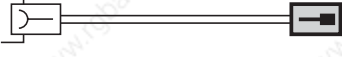
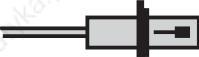
M23 PUR connecting cable Ø 8 mm [(4 x 0.14 mm ²) + 4(2 x 0.14 mm ²) + (4 x 0.5 mm ²)]			
Complete with connector (female) and coupling (male)	323897-xx	Complete with connector (female) and D-sub connector (male) for IK 115	324544-xx
			
With one connector (female)	309778-xx	Complete with connector (female) and D-sub connector (female) for IK 220	332115-xx
			
Cable without connectors	266306-01		
			

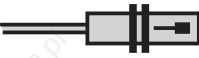
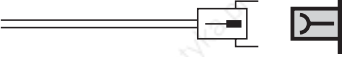
Connecting cable M23 for ECN 113 SSI with integrated line drop compensator from 10 to 30 V to 5 V			
Complete with connector (female) and coupling (male)	536699-xx	With one connector (female)	538797-xx
			

Connectors and couplings M23			
Coupling on encoder cable	Coupling (male), 17-pin	Mating element for encoder connecting element	Connector (female), 17-pin
			
For cable Ø 6 mm	291698-26	For connecting cable Ø 8 mm	291697-26
Connector for connection to subsequent electronics	Connector (male), 17-pin	Coupling	Coupling (male), 17-pin
			
For connecting cable Ø 8 mm	291697-27	For connecting cable Ø 8 mm	291698-27
	Mounted coupling with flange (male), 17-pin		Mounted coupling with flange (female), 17-pin
For cable Ø 6 mm Ø 8 mm	291698-41 291698-29	For cable Ø 8 mm	291698-35
	Mounted coupling with central fastening (male), 17-pin		Flange socket (female), 17-pin
For cable Ø 6 mm	291698-37		315892-10

Connecting cable M12 for EnDat 2.2 encoders without incremental signals			
Complete with M12 connector (female), 8-pin, and M12 connector (male), 8-pin, for purely serial data transmission	368330-xx	Complete with M12 connector (female) and D-sub connector (male) for IK 115/IK 215	524599-xx
			

General Electrical Information

Power Supply

The encoders require a **stabilized dc voltage U_P** as power supply. The respective specifications state the required power supply and the current consumption. The permissible ripple content of the dc voltage is:

- High frequency interference
 $U_{PP} < 250 \text{ mV}$ with $dU/dt > 5 \text{ V}/\mu\text{s}$
- Low frequency fundamental ripple
 $U_{PP} < 100 \text{ mV}$

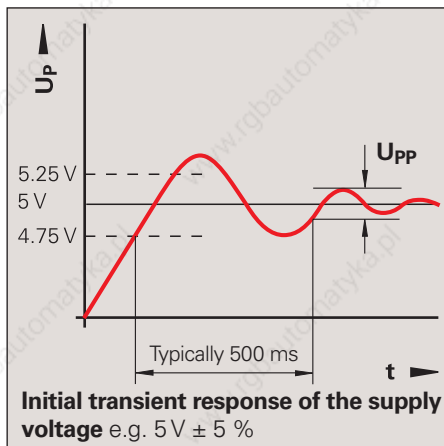

The values apply as measured at the encoder, i.e., without cable influences. The voltage can be monitored and adjusted with the device's **sensor lines**. If a controllable power supply is not available, the voltage drop can be halved by switching the sensor lines parallel to the corresponding power lines.

Calculation of the **voltage drop**:

$$\Delta U = 2 \cdot 10^{-3} \cdot \frac{L_C \cdot I}{56 \cdot A_P}$$

with ΔU : Voltage attenuation in V

L_C : Cable length in mm

I : Current consumption of the encoder in mA (see *Specifications*)

A_P : Cross section of power lines in mm^2

HEIDENHAIN cables	Cross section of power supply lines A_P			
	1 V _{PP} /TTL/HTL	11 μ A _{PP}	EnDat/SSI 17-pin	EnDat 8-pin
Ø 3.7 mm	0.05 mm ²	–	–	–
Ø 4.5/5.1 mm	0.14/0.05 ²⁾ mm ²	0.05 mm ²	0.05 mm ²	–
Ø 6/10 ¹⁾ mm	0.19/0.14 ³⁾ mm ²	–	0.08 mm ²	0.34 mm ²
Ø 8/14 ¹⁾ mm	0.5 mm ²	1 mm ²	0.5 mm ²	1 mm ²

- 1) Metal armor
- 2) Only on length gauges
- 3) Only for LIDA 400

Electrically Permissible Speed/ Traversing Speed

The maximum permissible shaft speed or traversing velocity of an encoder is derived from

- the **mechanically** permissible shaft speed/traversing velocity (if listed in the *Specifications*) and
- the **electrically** permissible shaft speed or traversing velocity.

For encoders with **sinusoidal output signals**, the electrically permissible shaft speed/traversing velocity is limited by the $-3\text{dB}/-6\text{dB}$ cutoff frequency or the permissible input frequency of the subsequent electronics.

For encoders with **square-wave signals**, the electrically permissible shaft speed/traversing velocity is limited by

- the maximum permissible scanning/output frequency f_{max} of the encoder and
- the minimum permissible edge separation a for the subsequent electronics

For angular or rotary encoders

$$n_{max} = \frac{f_{max}}{z} \cdot 60 \cdot 10^3$$

For linear encoders

$$v_{max} = f_{max} \cdot SP \cdot 60 \cdot 10^{-3}$$

where

n_{max} : Electrically permissible speed in rpm

v_{max} : Electrically permissible speed in m/min

f_{max} : Maximum scanning/output frequency of the encoder or input frequency of the subsequent electronics in kHz

z : Line count of the angle or rotary encoder per 360°

SP : Signal period of the linear encoder in μm

Cables

Lengths

The cable lengths listed in the *Specifications* apply only for HEIDENHAIN cables and the recommended input circuitry of subsequent electronics.

Durability

All encoders use polyurethane (PUR) cables. PUR cables are resistant to oil, hydrolysis and microbes in accordance with **VDE 0472**. They are free of PVC and silicone and comply with UL safety directives. The **UL certification** AWM STYLE 20963 80 °C 30 V E63216 is documented on the cable.

Temperature range

HEIDENHAIN cables can be used:
for stationary cables –40 to 85 °C
for moving cables –10 to 85 °C

Cables with limited resistance to hydrolysis and microbes are rated for up to 100 °C.

Bending radius

The permissible bending radii R depend on the cable diameter and the configuration:

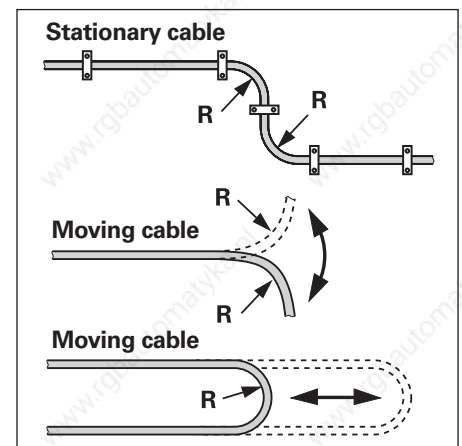

HEIDENHAIN cables	Stationary cable	Moving cable
Ø 3.7 mm	$R \geq 8 \text{ mm}$	$R \geq 40 \text{ mm}$
Ø 4.5 mm Ø 5.1 mm	$R \geq 10 \text{ mm}$	$R \geq 50 \text{ mm}$
Ø 6 mm	$R \geq 20 \text{ mm}$	$R \geq 75 \text{ mm}$
Ø 8 mm	$R \geq 40 \text{ mm}$	$R \geq 100 \text{ mm}$
Ø 10 mm ¹⁾	$R \geq 35 \text{ mm}$	$R \geq 75 \text{ mm}$
Ø 14 mm ¹⁾	$R \geq 50 \text{ mm}$	$R \geq 100 \text{ mm}$

Reliable Signal Transmission

Electromagnetic compatibility/ CE compliance

When properly installed, HEIDENHAIN encoders fulfill the requirements for electromagnetic compatibility according to 89/336/EEC with respect to the generic standards for:

- **Noise immunity EN 61000-6-2:**

Specifically:

- ESD EN 61000-4-2
- Electromagnetic fields EN 61000-4-3
- Burst EN 61000-4-4
- Surge EN 61000-4-5
- Conducted disturbances EN 61000-4-6
- Power frequency magnetic fields EN 61000-4-8
- Pulse-forming magnetic fields EN 61000-4-9

- **Interference EN 61000-6-4:**

Specifically:

- For industrial, scientific and medical (ISM) equipment EN 55011
- For information technology equipment EN 55022

Transmission of measuring signals— electrical noise immunity

Noise voltages arise mainly through capacitive or inductive transfer. Electrical noise can be introduced into the system over signal lines and input or output terminals. Possible sources of noise are:

- Strong magnetic fields from transformers and electric motors
- Relays, contactors and solenoid valves
- High-frequency equipment, pulse devices, and stray magnetic fields from switch-mode power supplies
- AC power lines and supply lines to the above devices

Isolation

The encoder housings are isolated against all circuits.

Rated surge voltage: 500 V

(preferred value as per VDE 0110 Part 1)

Protection against electrical noise

The following measures must be taken to ensure disturbance-free operation:

- Use only original HEIDENHAIN cables. Watch for voltage attenuation on the supply lines.
- Use connectors or terminal boxes with metal housings. Do not conduct any extraneous signals.
- Connect the housings of the encoder, connector, terminal box and evaluation electronics through the shield of the cable. Connect the shielding in the area of the cable inlets to be as induction-free as possible (short, full-surface contact).
- Connect the entire shielding system with the protective ground.
- Prevent contact of loose connector housings with other metal surfaces.
- The cable shielding has the function of an equipotential bonding conductor. If compensating currents are to be expected within the entire system, a separate equipotential bonding conductor must be provided.
- Also see EN 50178/4.98 Chapter 5.2.9.5 regarding "protective connection lines with small cross section." Connect HEIDENHAIN position encoders only to subsequent electronics whose power supply is generated through double or strengthened insulation against line voltage circuits. Also see **EN 364-4-41:** 1992, modified Chapter 411 regarding "protection against both direct and indirect touch" (PELV or SELV).

- Do not lay signal cables in the direct vicinity of interference sources (inductive consumers such as contactors, motors, frequency inverters, solenoids, etc.).
- Sufficient decoupling from interference-signal-conducting cables can usually be achieved by an air clearance of 100 mm or, when cables are in metal ducts, by a grounded partition.
- A minimum spacing of 200 mm to inductors in switch-mode power supplies is required. Also see **EN 50178/4.98** Chapter 5.3.1.1 regarding cables and lines, and **EN 50174-2/09.01**, Chapter 6.7 regarding grounding and potential compensation.
- When using **multiturn encoders in electromagnetic fields** greater than 30 mT, HEIDENHAIN recommends consulting with the main facility in Traunreut.

Both the cable shielding and the metal housings of encoders and subsequent electronics have a shielding function. The housings must have the **same potential** and be connected to the main signal ground over the machine chassis or by means of a separate potential compensating line. Potential compensating lines should have a minimum cross section of 6 mm² (Cu).

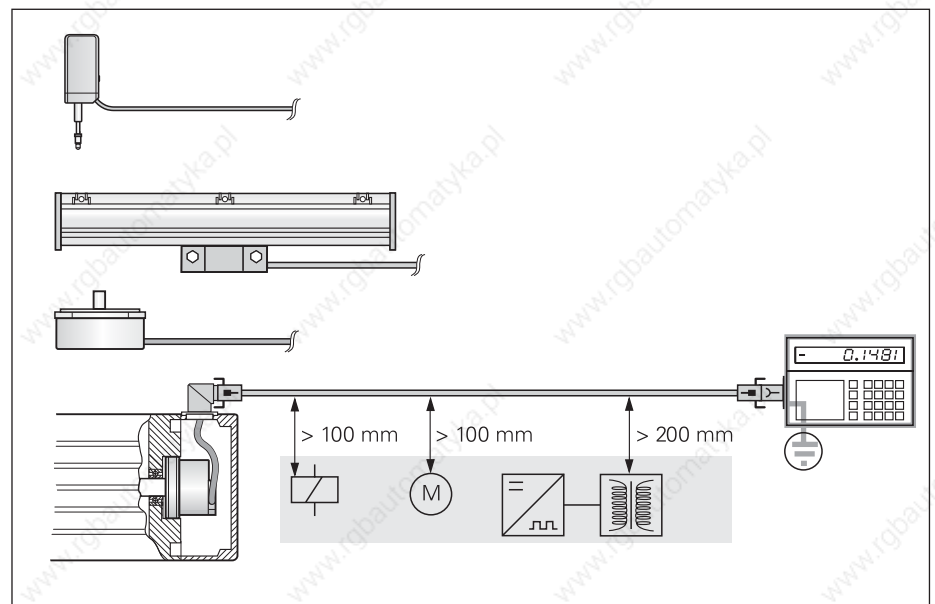

Minimum distance from sources of interference

Customer Service—Worldwide

HEIDENHAIN is represented by subsidiaries in all important industrial nations. In addition to the addresses listed here, there are many service agencies located worldwide. For more information, visit our Internet site or contact HEIDENHAIN in Traunreut, Germany.

Germany

See back of catalog

Europe

DR. JOHANNES HEIDENHAIN GmbH

Dr.-Johannes-Heidenhain-Straße 5

83301 Traunreut, Germany

☎ +49 (8669) 31-0

FAX +49 (8669) 5061

e-mail: info@heidenhain.de

www.heidenhain.de

AT

HEIDENHAIN

Dr.-Johannes-Heidenhain-Straße 5
83301 Traunreut, Deutschland

☎ +49 (8669) 31 13 37

FAX +49 (8669) 5061

e-mail: tba@heidenhain.de

GR

MB Milionis Vassilis

38, Scoufa Str.

St. Dimitrios

173 41 Athens, Greece

☎ (02 10) 933 66 07

FAX (02 10) 934 96 60

e-mail: bmlioni@otenet.gr

BE

HEIDENHAIN NV/SA

Pamelse Klei 47,
1760 Roosdaal-Pamel, Belgium

☎ (054) 34 31 58

FAX (054) 34 31 73

e-mail: sales@heidenhain.be

HU

HEIDENHAIN Kereskedelmi Képviselet

Hrvnák Pál utca 13.

1237 Budapest, Hungary

☎ (1) 421 09 52

FAX (1) 421 09 53

e-mail: info@heidenhain.hu

RO

CH

HEIDENHAIN (SCHWEIZ) AG

Post Box; Vierstrasse 14
8603 Schwerzenbach, Switzerland

☎ (044) 806 27 27

FAX (044) 806 27 28

e-mail: hch@heidenhain.ch

IT

HEIDENHAIN ITALIANA S.r.l.

Via Asiago 14

20128 Milano, Italy

☎ 02 270 75-1

FAX 02 270 75-2 10

e-mail: info@heidenhain.it

CZ

HEIDENHAIN s.r.o.

Stremchová 16

106 00 Praha 10, Czech Republic

☎ 2 72 65 81 31

FAX 2 72 65 87 24

e-mail: heidenhain@heidenhain.cz

NL

HEIDENHAIN NEDERLAND B.V.

Post Box 92, 6710 BB EDE

Copernicuslaan 34, 6716 BM EDE

The Netherlands

☎ (0318) 581800

FAX (0318) 581870

e-mail: verkoop@heidenhain.nl

SK

DK

TP TEKNIK A/S

Korskildelund 4

2670 Greve, Denmark

☎ (70) 10 09 66

FAX (70) 10 01 65

e-mail: tp-gruppen@tp-gruppen.dk

NO

HEIDENHAIN NUF

Boks 63

7301 Orkanger, Norway

☎ (072) 48 00 48

FAX (072) 48 00 49

e-mail: audun.grimstad@heidenhain.se

ES

FARRESA ELECTRONICA S.A.

Les Corts, 36-38 bajos

08028 Barcelona, Spain

☎ 9 34 09 24 91

FAX 9 33 39 51 17

e-mail: farresa@farresa.es

PL

APS

Populama 56

02-473 Warszawa, Poland

☎ (22) 863 97 37

FAX (22) 863 97 44

e-mail: aps@apservis.com.pl

FI

HEIDENHAIN AB

Mikkellänkallio 3

02770 Espoo, Finland

☎ (09) 867 64 76

FAX (09) 86 76 47 40

e-mail: info@heidenhain.fi

PT

FARRESA ELECTRÓNICA LDA.

Rua do Outeiro, 1315 1º M

4470 Maia, Portugal

☎ (22) 947 81 40

FAX (22) 947 81 49

e-mail: fep@farresa.pt

FR

HEIDENHAIN FRANCE sarl

2, Avenue de la Cristallerie

92316 Sèvres, France

☎ 01 41 14 30 00

FAX 01 41 14 30 30

e-mail: info@heidenhain.fr

SE

HEIDENHAIN AB

Storsåtragränd 5

12739 Skärholmen, Sweden

☎ (08) 53 19 33 50

FAX (08) 53 19 33 77

e-mail: sales@heidenhain.se

GB

HEIDENHAIN (G.B.) Limited

200 London Road, Burgess Hill

West Sussex RH15 9RD, Great Britain

☎ (01444) 24 77 11

FAX (01444) 87 00 24

e-mail: sales@heidenhain.co.uk

TR

T&M Mühendislik Mümessillik

Sanayi ve Ticaret Ltd. Pirketi

Zincirlikösk Sok

Doga Apt. No. 11/1

34728 Erenköy/Istanbul, Turkey

☎ (2 16) 3 02 23 45

FAX (2 16) 3 02 43 51

Asia

CN HEIDENHAIN (Tianjin)
Optics and Electronics Co., Ltd.
Room 808, The Exchange Beijing Tower 4
No. 118 Jian Guo Lu Yi
Chaoyang District
Beijing 100022, China
☎ (86) 1065673238
☎ (86) 1065672789
e-mail: sales@heidenhain.com.cn

HK HEIDENHAIN LIMITED
Unit 2, 15/F, APEC Plaza
49 Hoi Yuen Road
Kwun Tong
Kowloon, Hong Kong
☎ (852) 27591920
☎ (852) 27591961
e-mail: service@heidenhain.com.hk

IL NEUMO VARGUS
Post Box 57057
34-36, Itzhak Sade St.
Tel-Aviv 61570, Israel
☎ (3) 5373275
☎ (3) 5372190
e-mail: neuemoil@netvision.net.il

IN ASHOK & LAL
Post Box 5422
12 Pulla Reddy Avenue
Chennai – 600 030, India
☎ (044) 26151289
☎ (044) 26478224
e-mail: ashoklal@satyam.net.in

JP HEIDENHAIN K.K.
Kudan Center Bldg. 10th Floor
Kudankita 4-1-7, Chiyoda-ku
Tokyo 102-0073 Japan
☎ (03) 3234-7781
☎ (03) 3262-2539
e-mail: sales@heidenhain.co.jp

KR HEIDENHAIN LTD.
Suite 1415, Family Tower Building
958-2 Yeongtong-Dong, Paldal-Gu, Suwon
442-470 Kyeonggi-Do, Republic of Korea
☎ (82) 312011511
☎ (82) 312011510
e-mail: info@heidenhain.co.kr

SG HEIDENHAIN PACIFIC PTE LTD.
51, Ubi Crescent
Singapore 408593
☎ (65) 6749-3238
☎ (65) 6749-3922
e-mail: info@heidenhain.com.sg

TH HEIDENHAIN (THAILAND) LTD
52/72 Moo5
Chaloem Phra Kiat Rama 9 Rd
Nongbon, Pravate, Bangkok 10250,
Thailand
☎ (66) 2/398-4147
☎ (66) 2/398-4143
e-mail: info@heidenhain.co.th

TW HEIDENHAIN Co., Ltd.
No. 12-5, Gong 33rd Road
Taichung Industrial Park
Taichung 407, Taiwan, R.O.C.
☎ (886-4) 23588977
☎ (886-4) 23588978
e-mail: info@heidenhain.com.tw

America

AR NAKASE Asesoramiento Tecnico
de Carlos Klug
Calle 49 Nr. 5764/66
B1653AOX Villa Ballester,
Provincia de Buenos Aires, Argentina
☎ (11) 47683643
☎ (11) 47682413
e-mail: nakase@usa.net

BR DIADUR Indústria e Comércio Ltda.
Rua Sérvia, 329, Santo Amaro
04763-070 – São Paulo – SP, Brazil
☎ (011) 5523-6777
☎ (011) 5523-1411
e-mail: assistenciatec@diadur.com.br

CA HEIDENHAIN CORPORATION
Canadian Regional Office
11-335 Admiral Blvd., Unit 11
Mississauga, Ontario L5T 2N2, Canada
☎ (905) 670-8900
☎ (905) 670-4426
e-mail: info@heidenhain.com

MX HEIDENHAIN CORPORATION MEXICO
Av. Las Américas 1808
Fracc. Valle Dorado
20235, Aguascalientes, Ags., Mexico
☎ (449) 9130870
☎ (449) 9130876
e-mail: info@heidenhain.com

US HEIDENHAIN CORPORATION
333 State Parkway
Schaumburg, IL 60173-5337, U.S.A.
☎ (847) 490-1191
☎ (847) 490-3931
e-mail: info@heidenhain.com

Africa

ZA MAFEMA SALES SERVICES C.C.
107 - 16th Road Unit B3
Tillbury Business Park, Randjiespark
Midrand, 1685 - Gauteng Province,
South Africa
☎ (11) 3144416
☎ (11) 3142289
e-mail: mailbox@mafema.co.za

HEIDENHAIN

DR. JOHANNES HEIDENHAIN GmbH

Dr.-Johannes-Heidenhain-Straße 5

83301 Traunreut, Germany

☎ +49 (8669) 31-0

FAX +49 (8669) 5061

e-mail: info@heidenhain.de

www.heidenhain.de

Germany – Technical Information

HEIDENHAIN Technisches Büro Nord

Rhinstraße 134
12681 Berlin, Deutschland
☎ (030) 54705-240
FAX (030) 54705-200
e-mail: tbn@heidenhain.de

HEIDENHAIN Technisches Büro West

Bandstahlstraße 2
58093 Hagen, Deutschland
☎ (02331) 9579-0
FAX (02331) 9579-49
e-mail: tbw@heidenhain.de

HEIDENHAIN Technisches Büro Südost

Dr.-Johannes-Heidenhain-Straße 5
83301 Traunreut, Deutschland
☎ (08669) 311345
FAX (08669) 5061
e-mail: tbs@heidenhain.de

HEIDENHAIN Technisches Büro Mitte

Kaltes Feld 22
08468 Heinsdorfergrund, Deutschland
☎ (03765) 69544
FAX (03765) 69628
e-mail: tbm@heidenhain.de

HEIDENHAIN Technisches Büro Südwest

Eichachstraße 20
72131 Offerdingen, Deutschland
☎ (07473) 22733
FAX (07473) 21764
e-mail: tbsw@heidenhain.de

Germany – Information and Sales

KLEIN & MISTELE GmbH

Im Hegen 14a
22113 Oststeinbek
☎ (040) 801057
e-mail: info@klein-mistele.de

RHEINWERKZEUG KG

Gablonzstraße 8
38114 Braunschweig
☎ (0531) 25659-0
e-mail: info@rheinwerkzeug.de

FRIEDR. STRACK GmbH

Buchenhofener Straße 19
42329 Wuppertal
☎ (0202) 3850
e-mail: verkauf@strack-maschinen.de

Walter BAUTZ GmbH

Mess- und Spanntechnik
Mühlenweg 8
64347 Griesheim
☎ (06155) 8422-0
e-mail: info@walterbautz-gmbh.de

BRAUN Werkzeugmaschinen Vertrieb und Service GmbH

Industriestraße 41
72585 Riederich
☎ (07123) 9343-0
e-mail: info@braun-werkzeugmaschinen.de

HAAS Werkzeugmaschinen GmbH

Heinrich-Hertz-Straße 16
78052 VS-Villingen
☎ (07721) 9559-0
e-mail: info@haas-werkzeugmaschinen.de

BRAUN Werkzeugmaschinen Vertrieb und Service GmbH

Anton-Pendle-Straße 3
82275 Emmering
☎ (08141) 9714
e-mail: albert@braunemm.de

TEDI Technische Dienste GmbH

Werkstraße 113
19061 Schwerin
☎ (0385) 61721-0
e-mail: schwerin-jh@tedi-online.de

TEDI Technische Dienste GmbH

Liebkechtstraße 65
39110 Magdeburg
☎ (0391) 732529-0
e-mail: magdeburg-jh@tedi-online.de

MOSER Industrie-Elektronik GmbH

Geneststraße 7/8
10829 Berlin
☎ (030) 7515737
e-mail: mosergmbh.berlin@t-online.de

TEDI Technische Dienste GmbH

Großenhainer Straße 99
01127 Dresden
☎ (0351) 4278020
e-mail: dresden-jh@tedi-online.de

WWZ-Vertrieb GmbH

Werkzeugmaschinen
An der Allee 9
99848 Wutha-Farnroda
☎ (036921) 23-0
e-mail: j.wellendorf@wwz.vertrieb.de

HEMPEL Werkzeugmaschinen

Pestalozzistraße 58
08393 Meerane
☎ (03764) 3064
e-mail: info@hempel-wzm.de

KL-Messtechnik & Service GmbH

Am Weichselgarten 34
91058 Erlangen
☎ (09131) 480056-0
e-mail: info@kl-messtechnik.de

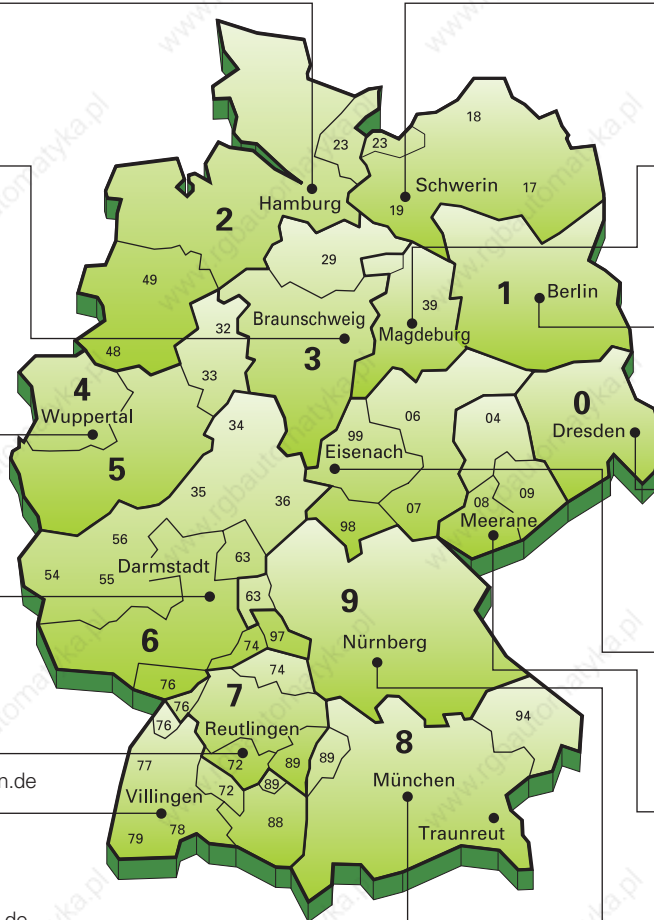

Fold here for filing!