



**EMERSON**<sup>™</sup>  
Industrial Automation

## Servo Motors

### Product Data

Unimotor HD, Unimotor FM,  
NT Series and XV Series

0.9 - 752lb-in (0.1 - 85.0Nm)  
230V / 460V



# Contents

<b>Introduction</b> .....	3	<b>Unimotor FM 230V / 460V</b> .....	26
<b>A Wide Range of Rugged and Reliable Servo Motors</b> .....	4	Key Features.....	26
<b>Selecting the Right Motor for the Right Drive</b> .....	5	Order Information.....	27
<b>Unimotor HD 230V / 460V</b> .....	6	55mm Frame Ratings & Dimensions.....	28-29
Key Features.....	6	75mm Frame Ratings & Dimensions.....	30-31
Order Information.....	7	95mm Frame Ratings & Dimensions.....	32-33
55mm Frame Ratings and Dimensions .....	8	115mm Frame Ratings & Dimensions.....	34-35
67mm Frame Ratings and Dimensions .....	9	142mm Frame Ratings & Dimensions.....	36-37
89mm Frame Ratings and Dimensions .....	10	190mm Frame Ratings & Dimensions.....	38-39
115mm Frame Ratings and Dimensions .....	11	460V 190mm Frame Ratings & Dimensions.....	40-41
142mm Frame Ratings and Dimensions .....	12	<b>Unimotor FM Fan Blown Motors 460V</b> .....	42
190mm Frame Ratings and Dimensions .....	13	Ordering Information.....	42
Unimotor HD Selection Considerations .....	14	75mm Frame Ratings & Dimensions.....	43
<b>NT Motor 230V</b> .....	16	95mm Frame Ratings & Dimensions.....	44
Key Features.....	16	115mm Frame Ratings & Dimensions.....	45
Order Information.....	16	142mm Frame Ratings & Dimensions.....	46
2-inch Frame Ratings and Dimensions.....	17	190mm Frame Ratings & Dimensions.....	47
3-inch Frame Ratings and Dimensions.....	18	Unimotor FM Motor Selection Considerations .....	48
NT Motor Selection Considerations .....	20	<b>Cables for Servo Motors</b> .....	50
<b>XV Motor 230V</b> .....	21	Cable Selection – Unimotor HD, Unimotor FM, NT (-EOxS) ...	51
Key Features.....	21	Cable Selection – NT Motors to Drives .....	56
Order Information.....	21	Cable Selection – XV Motors to Drives .....	58
40mm Frame Ratings and Dimensions .....	22	<b>Unimotor FM Fan Kits</b> .....	59
60/80mm Frame Ratings and Dimensions.....	23		
130mm Frame Ratings and Dimensions .....	24		
XV Motor Selection Considerations .....	25		



Certificate No. EMS 54446  
003  
ISO 30610



Certificate No. Q 95176  
003  
ISO 9001

**RoHS**  
Compliant



# A Servo Motor for Every Application

## Reliability and Innovation

Control Techniques designs its products using a proven development process that prioritizes innovation and reliability. This process has resulted in Control Techniques' market-leading reputation for performance and quality.

Control Techniques offers a wide range of reliable servo motors designed to meet specific application requirements. When matched to a Control Techniques Unidrive SP, Digitax ST Epsilon EP or MDS Servo drive, the resulting drive/motor combination provides an optimized system in terms of ratings, performance, cost and ease of use.

Today, businesses of all sizes are searching for partners who understand the unique demands of today's global economy. Time and again they turn to Emerson Industrial Automation. With our world-class brands, broad industry experience and extensive global presence, Emerson Industrial Automation is uniquely positioned to deliver cost-effective solutions for the ever-changing industrial manufacturing market.



*The Unimotor HD series servo motor expands the capabilities of Control Techniques motion systems that provide high torque in a small size as well as support for incremental encoders, absolute encoders and resolver motor feedback.*

## Performance Advantage

### Unimotor HD

Compact low-inertia servo motor for high-dynamic applications

- **Voltage Rating:** 230V/460V
- **Continuous Torque:** 6.4 to 752lb-in (0.72 to 85.0Nm)
- **Multiple Feedback Choices:** resolver, encoder and abs encoder
- **Frame Sizes:** 55, 67, 89, 115, 142 and 190mm
- **Ratings:** IP65; UL, CE and RoHS compliant

### NT Motor

Compact NEMA or metric flange motors

- **Voltage Rating:** 230V
- **Continuous Torque:** 7.5 to 56lb-in (0.85 to 6.3Nm)
- **Multiple Feedback Choices:** resolver, encoder and abs encoder
- **Flying Lead Option**
- **Frame Sizes:** English (NEMA 23 or 34) or Metric (IEC-72-1)
- **Ratings:** IP65; UL and CE compliant (RoHS options available)

### XV Motor

Economical metric motors

- **Voltage Rating:** 230V
- **Continuous Torque:** 0.9 to 101lb-in (0.11 to 11.5Nm)
- **Frame Sizes:** 40, 60, 80 and 130mm
- **Ratings:** IP55 and IP65; UL, CE and RoHS compliant

### Unimotor FM

Designed for flexible configuration for use in a wide range of applications with a high inertia option

- **Voltage Rating:** 230V/460V
- **Continuous Torque:** 6.4 to 1204lb-in (0.72 to 136Nm)
- **Multiple Feedback Choices:** resolver, encoder and abs encoder with multiple connector options
- **Frame Sizes (with NEMA flange options):** 55, 75, 95, 115, 142 and 190mm
- **Ratings:** IP65; UL and CE compliant

### Unimotor FM Fan Blown

Based on Unimotor FM mechanics with modified electromagnetic construction, the fan blown version is designed to give greater performance across the torque range.





- **Voltage Rating:** 460V
- **Continuous Torque:** 46 to 699lb-in (5.2 - 79.0Nm)
- **Multiple Feedback Devices:** resolver, incremental and absolute encoders
- **Frame Sizes:** 75,95,115,142 and 190mm
- **Ratings:** UL and CE compliant
- **Fan:** 208Vac

*Shaft seals standard on Unimotor HD, FM and NT Series motors*



# A Wide Range of Rugged and Reliable Servo Motors

## Servo Motor Product Matrix

	HD Motors	NT Motors	XV Motors	FM Motors	FM Fan Blown Motors
					
<b>Motor Family</b>	Page 6	Page 16	Page 21	Page 26	Page 42
<b>Drive Voltage (Vac)</b>	230 / 460	230	230	230 / 460	460
<b>Continuous Stall Torque</b>	Up to 752lb-in (85.0Nm)	Up to 56lb-in (6.3Nm)	Up to 101lb-in (11.4Nm)	Up to 648lb-in (73.2Nm)	Up to 699lb-in (79Nm)
<b>Flange</b>	IEC	IEC, NEMA	Metric	IEC (NEMA, option)	IEC (NEMA, option)
<b>Frame</b>	55, 67, 89, 115, 142, 190mm	2, 3in	40, 60, 80, 130mm	55, 75, 95, 115, 142, 190mm	75, 95, 115, 142, 190mm
<b>Inertia</b>	Low	Low	Low, medium	Med. (high-inertia opt.)	Med. (high-inertia opt.)
<b>Peak Torque</b>	Up to 2257lb-in (255.0Nm)	Up to 144lb-in (16.2Nm)	Up to 301lb-in (34Nm)	Up to 3611lb-in (408Nm)	Up to 1559lb-in (176Nm)
<b>Base Speeds</b>	Up to 6000rpm	Up to 5000rpm	Up to 5000rpm	Up to 6000rpm	Up to 6000rpm
<b>Brake Options</b>	24Vdc Holding Brake				
<b>Connector Options</b>	Circular style frame mounted 90° and rotatable	MS or circular style frame mounted, MS style on 40in lead, flying leads, drive connector terminated leads (20ft max.)	AMP Mat-n-Loc on 1ft. lead (40 to 80mm); MS style frame-mounted (130mm)	Circular style frame-mounted 90° and rotatable; optional 90° fixed, vertical, or mixed	Circular style frame-mounted 90° and rotatable; optional 90° fixed, vertical, or mixed
<b>Feedback Options</b>	Incremental encoders, optical SinCos single- and multi-turn, inductive SinCos single and multi turn, resolver, Hiperface (SICK) and EnDAT	Incremental 2048 line count, inductive absolute, resolver	Incremental 2048 line count	Incremental encoders, optical SinCos single- and multi-turn, inductive SinCos single and multi-turn, resolver, Hiperface and EnDAT	Incremental encoders, optical SinCos single- and multi-turn, inductive SinCos single and multi-turn, resolver, Hiperface and EnDAT
<b>Ingress Protection</b>	IP65	IP65, IP67, IP68	IP55, IP65	IP65	IP20
<b>Approvals</b>	CE, UL, RoHS	CE, UL (RoHS opt.)	CE, UL, RoHS	CE, UL, RoHS	CE, UL, RoHS
<b>Shaft Seals</b>	✓	✓		✓	✓

## Why Motion Customers Choose Control Techniques' Motion Control Solutions...

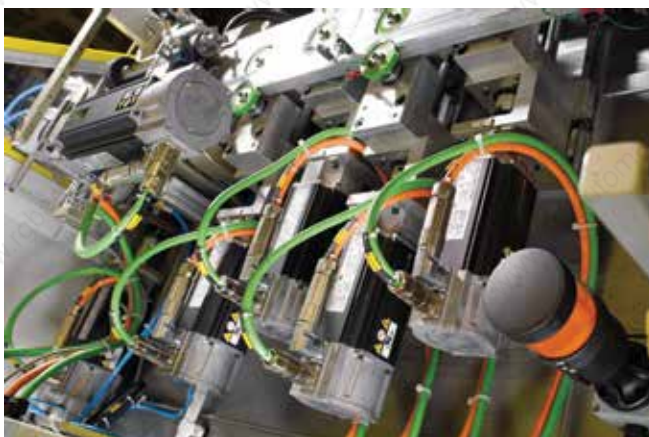

- A full line of servo motors up to 1200lb-in
- Single-source motion control lowers total system costs
- FREE software offers the ultimate programming capability and greatly reduces programming time
- Multiple fieldbus options including EtherCAT, EtherNet I/P, Modbus TCP/IP and more
- High-speed, peer-to-peer communications
- 14 feedback types supported as standard
- Integrated programs eliminate need for PLC
- Drive and Application Center support
- Zero-space EMI and dynamic braking options
- AC drives with closed-loop vector control and sensorless rotor control

# Selecting the Right Motor for the Right Drive

Control Techniques drive-and-motor combinations provide an optimized system in terms of ratings, performance, cost and ease of use. Use Control Techniques' FREE CTSize software (for Control Techniques Epsilon and MDS Servo drives) or CTSelect (for Control Techniques Unidrive SP and Digitax ST drives) to select system components or manually select the system using the following steps.

1. Determine the application's continuous and peak torque requirements at various motor shaft speeds, then refer to motor data tables and the visual-reference overview to help determine which motor family will be most appropriate for the application.
2. Once the motor family is selected, use this brochure to select a specific motor model that delivers the required torque and speed. Make note of the continuous and peak current (Amps) requirements of the selected motor.
3. Check the specification tables in Control Techniques' brochures for Digitax ST (BRO-DST-1107), Epsilon EP (BRO-EPP-1107) or Unidrive SP (BRO-USPSRVO-1107) Servo drives to select the drive model that delivers adequate continuous and peak torque for the selected motor.
4. Go to the table of contents of this brochure to select the motor power and feedback cables for the selected motor and drive. Confirm that the ratio of rotor inertia to load inertia is <10:

$$\text{load inertia/rotor inertia} < 10$$

Note: A gear reducer will reduce the load inertia based on the following equation:

$$\text{Reflected load inertia} = \text{load inertia/gear ratio}^2$$

Note: When specifying a motor system, be sure to consider such options as user-interfaces (HMI), braking resistors and other options and accessories that will enhance the system's performance and value.

## Electronic Nameplates

Some motors fitted with high-resolution SinCos or absolute encoders are pre-loaded with the motor "electronic nameplate" data during the manufacturing process. This data can be read by Control Techniques' Servo drives and used to automatically optimize the drive settings. This feature simplifies commissioning and maintenance, ensures consistent performance and saves time.

For comprehensive Control Techniques motor drive information, refer to the following brochures:

**Unidrive SP** (BRO-USP-1107), **Unidrive SP Servo** (BRO-USPSRVO-1107), **Digitax ST** (BRO-DST-1107), **Epsilon EP** (BRO-EPP-1107)

**Example** (using Control Techniques' NT Motor family and Digitax ST Servo drive family):

**Step 1:** The application requires 12lb-in continuous torque.

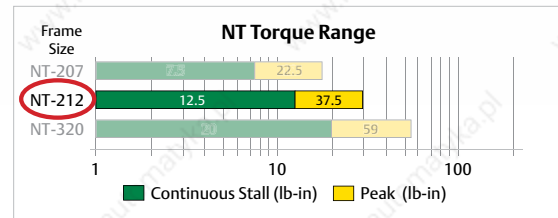

**Step 2:** The Control Techniques Servo Motors brochure lists the NT-212 motor with 2.7A stall current.

Motor Frame Size	2in	
	Voltage 230Vrms	
Model	NT-207	<b>NT-212</b>
Continuous Stall Torque (lb-in)	7.5	12.5
Continuous Stall Torque (Nm)	0.85	1.4
Standard Inertia (lb-in-sec <sup>2</sup> )	0.000094	<b>0.000164</b>
Standard Inertia (kgm <sup>2</sup> )	0.0000106	<b>0.0000185</b>
Peak Torque (lb-in)	22.5	37.5
Peak Torque (Nm)	2.54	4.24
Maximum Cogging (lb-in)	0.094	0.12
Maximum Cogging (Nm)	0.011	0.014
Motor Weight (lbs)	3	4
Motor Weight (kg)	1.36	1.81
Rated Speed 5000 rpm Kt (Nm/A) =	5.12	5.08
Kt (Nm/A) =	0.58	0.57
Ke (V/krpm) =	35	34.7
Rated Torque (lb-in)	7.50	12.50
Rated Torque (Nm)	0.85	1.4
Stall Current (A)	1.7	<b>2.7</b>
Rated Power (kW)	0.432	0.740
R (ph-ph) (Ω)	11.1	4.56
L (ph-ph) (mH)	39.1	18.9

**Step 3:** Select the Digitax ST drive with adequate current rating.

## Ratings — Digitax ST

Drive Model Number	Voltage / Ø	Output Current*	
		Cont. A	Peak A
DST1201	200-230 3Ø	1.7	5.1
<b>DST1202</b>	200-230 3Ø	<b>3.8</b>	<b>11.4</b>
DST1203	200-230 3Ø	5.4	16.2
DST1204	200-230 3Ø	7.6	22.8
DST1401	380-480 3Ø	1.5	4.5

Drive switching frequency at 6kHz for rated performance

\*Peak current is duty cycle limited

\*\*Derate continuous current above 6kHz drive switching frequency

# Unimotor HD 230V / 460V

## Compact, Powerful High-Dynamic AC Servo Motors

Designed for maximum torque density, the Unimotor HD brushless AC Servo motor series provides an exceptionally compact, low-inertia solution for applications that require very high torque during rapid acceleration and deceleration profiles. Unimotor HD motors fitted with high-resolution SinCos or absolute encoders are pre-loaded with the motor “electronic nameplate” data during the manufacturing process. This data can be read by Control Techniques Servo drives and used to automatically optimize the drive settings. This feature simplifies commissioning and maintenance, ensures consistent performance and saves time.

The Unimotor HD torque profile is closely matched to Digitax ST Servo drives providing up to 300% peak overload for maximum dynamic performance.

### Key Features

- Torque range: 6.4 to 752lb-in (0.72 to 85.0Nm)
- High torque-to-inertia ratio for high-dynamic performance
- Compact and powerful
- Optional holding brake
- IP65 conformance
- Segmented stator design
- World class performance
- Winding to suit 230V and 460V
- Speeds include 2000, 3000, 4000 and 6000rpm
- Large shafts to increase torsional rigidity
- Multiple feedback options:
  - Incremental encoder: high accuracy, medium resolution
  - Inductive absolute: medium accuracy, medium resolution, single-turn and multi-turn
  - Optical SinCos/absolute: high accuracy, high resolution, single-turn and multi-turn
  - Hiperface (SICK) and EnDAT (Heidenhain) protocols supported
  - Resolver: robust for extreme applications and conditions; lower accuracy, medium resolution

### Approvals



## Unimotor <sup>hd</sup>



Unimotor HD motors (shown with a Control Techniques Digitax ST Servo drive).

### Unimotor HD Torque Range

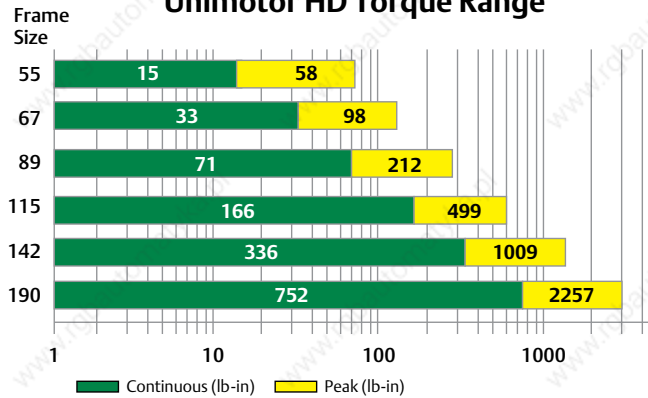



# Unimotor HD 230V / 460V Order Information

Use the information below to create an order code for a Unimotor HD (top row is an example).

089	UD	B	30	5	B	A	CA		A
Frame Size	Motor Voltage	Stator Length	Speed	Brake (24V)	Connection Type	Output Shaft	Feedback Device		Inertia
		055 - 089 Frame	055-067 Frame	055 Frame			055-067 Frames		
055	ED = 230V	A	30 = 3000 rpm	0 = Not Fitted (Std)	055 - 115, 190 Frames	A = Keyed*	AR = Resolver		A = Standard
067	UD = 460V	B	60 = 6000 rpm	1 = Holding Brake			CR = Incremental Encoder (Renco)**	4096 ppr (R35i)	
089		C	089 Frame	067-190 Frames	B = Power size		EM = Inductive SinCos Multi-Turn**	EQI 1130 - EnDat 2.1	
115		115 Frame	30 = 3000 rpm	0 = Not Fitted (Std)	1.5 and Signal		FM = Inductive SinCos Single-Turn	ECI 1118 - EnDat 2.1	
142		B	40 = 4000 rpm	5 = Holding Brake	90° Rotatable		089-115 Frames		
190		C	60 = 6000 rpm		142 Frame		AE = Resolver		
		D	115 Frame				CA = Incremental Encoder (SICK)**	4096 ppr (CFS50)	
		142 Frame	20 = 2000 rpm		B = Power size		EB = Optical SinCos Multi-Turn	EQN 1325 - EnDat 2.2	
		C	30 = 3000 rpm		1.0 and Signal		FB = Optical SinCos Single-Turn	ECN 1313 - EnDat 2.2	
		D	142 Frame		90° Rotatable		EC = Inductive SinCos Multi-Turn**	EQI 1331 - EnDat 2.1	
		E	10 = 1000 rpm		J = Power size		FC = Inductive SinCos Single-Turn	ECI 1319 - EnDat 2.1	
		190 Frame	15 = 1500 rpm		1.5 and Signal 90° Rotatable on 142		RA = Optical SinCos Multi-Turn***	SRM 50 (GEN 2) - Hiperface	
		C	20 = 2000 rpm				SA = Optical SinCos Single-Turn	SRS 50 (GEN 2) - Hiperface	
		D	30 = 3000 rpm						
		F	190 Frame						
			10 = 1000 rpm						
			15 = 1500 rpm						
			20 = 2000 rpm						

NOTES:  
 \*Half key provided to create a smooth shaft  
 \*\*Stocked motor, standard feedback  
 \*\*\*Limited quantities, normally stocked

## Stocked Motors

Unbraked Motors						
Stall Torque (lb-in)	Stall Torque (Nm)	Speed rpm	230V Order Code	Stall Current (A)	460V Order Code	Stall Current (A)
12.8	1.45	6000	067EDA600BACRA	3.12	067UDA600BACRA	1.81
22.5	2.55	3000	067EDB300BACRA	2.74	067UDB300BACRA	1.59
22.5	2.55	6000	067EDB600BACRA	5.48	067UDB600BACRA	3.19
48.7	5.50	3000	089EDB300BACAA	5.91	089UDB300BACAA	3.44
48.7	5.50	4000	089EDB400BACAA	7.86	089UDB400BACAA	4.58
70.8	8.00	3000	089EDC300BACAA	8.6	089UDC300BACAA	5.0
70.8	8.00	4000	089EDC400BACAA	11.43	089UDC400BACAA	6.67
90.3	10.2	3000	115EDB300BACAA	10.97	115UDB300BACAA	6.38
129.0	14.6	3000	115EDC300BACAA	15.7	115UDC300BACAA	9.13
166.0	18.8	3000			115UDD300BACAA	11.75
221.3	25.0	3000			142UDC300BACAA	15.6
336.3	38.0	3000			142UDE300BACAA	23.8
460.2	52.0	2000			190UDC200BACAA	21.7
752.3	85.0	1500			190UDF150BACAA	26.6

Braked Motors						
Stall Torque (lb-in)	Stall Torque (Nm)	Speed rpm	230V Order Code	Stall Current (A)	460V Order Code	Stall Current (A)
22.5	2.55	3000	067EDB305BACRA	2.74	067UDB305BACRA	1.59
70.8	8.0	3000	089EDC305BACAA	8.6	089UDC305BACAA	5.0
129	14.6	3000	115EDC305BACAA	15.7	115UDC305BACAA	9.13
336.3	38.0	3000			142UDE305BACAA	23.8
752.3	85.0	1500			190UDE155BACAA	26.6

NOTE:  
 • Stocked motors cover the range of HD motors and are available with short lead times for low quantities; consult factory for lead times for high-volume orders or on select feedback options

All Unimotor HD motors feature connections that rotate for easier cable routing and installation.



# Unimotor HD 55mm Frame Ratings and Dimensions

Motor Frame Size (mm)	055ED			055UD		
Voltage (Vrms)	200-240			380-480		
Frame Length	A	B	C	A	B	C
Continuous Stall Torque (lb-in)	6.37	10.44	14.6	6.37	10.44	14.6
Continuous Stall Torque (Nm)	0.72	1.18	1.65	0.72	1.18	1.65
Peak Torque (lb-in)	25.49	41.78	58.42	25.49	41.78	58.42
Peak Torque (Nm)	2.88	4.72	6.6	2.88	4.72	6.6
Inertia (lb-in-sec <sup>2</sup> )	0.00012	0.00022	0.00032	0.00012	0.00022	0.00032
Inertia (kgm <sup>2</sup> )	0.000014	0.000025	0.000036	0.000014	0.000025	0.000036
Motor Weight (lb)	2.64	3.3	3.96	2.64	3.3	3.96
Motor Weight (kg)	1.2	1.5	1.8	1.2	1.5	1.8
Number of Poles	8	8	8	8	8	8
Speed 3000 rpm Kt (lb-in/A) =	6.55	7.7	8.05	6.55	13.19	14.6
Kt (Nm/A) =	0.74	0.87	0.91	0.74	1.49	1.65
Ke (V/krpm) =	45	52.5	55	45	90	100
Rated Torque (lb-in)	6.2	9.29	13.1	6.2	9.29	13.1
Rated Torque (Nm)	0.7	1.05	1.48	0.7	1.05	1.48
Stall Current (A)	0.97	1.36	1.81	0.97	0.79	1
Rated Power (hp)	0.29	0.44	0.62	0.29	0.44	0.62
Rated Power (kW)	0.22	0.33	0.46	0.22	0.33	0.46
R (ph-ph) (Ω)	28.00	14.12	9.53	28.00	45.00	31.00
L (ph-ph) (mH)	50.00	32.00	23.00	50.00	100.00	75.00
Speed 6000 rpm Kt (lb-in/A) =	3.98	3.81	4.25	6.55	6.99	7.35
Kt (Nm/A) =	0.45	0.43	0.48	0.74	0.79	0.83
Ke (V/krpm) =	27	26	29	45	47.5	50
Rated Torque (lb-in)	6.02	7.97	10.62	6.02	7.97	10.62
Rated Torque (Nm)	0.68	0.9	1.2	0.68	0.9	1.2
Stall Current (A)	1.61	2.74	3.44	0.97	1.49	1.99
Rated Power (hp)	0.58	0.76	1.01	0.58	0.76	1.01
Rated Power (kW)	0.43	0.57	0.75	0.43	0.57	0.75
R (ph-ph) (Ω)	8.50	3.55	2.38	28.00	10.70	7.80
L (ph-ph) (mH)	16.00	8.20	6.30	50.00	25.00	20.00

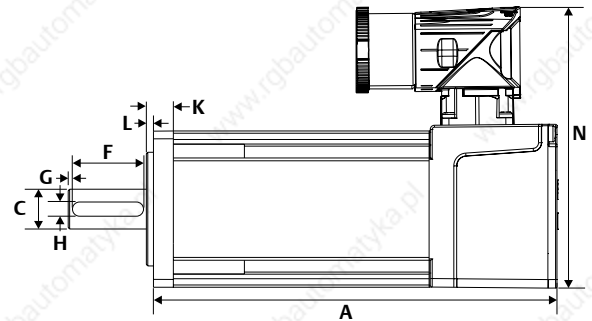
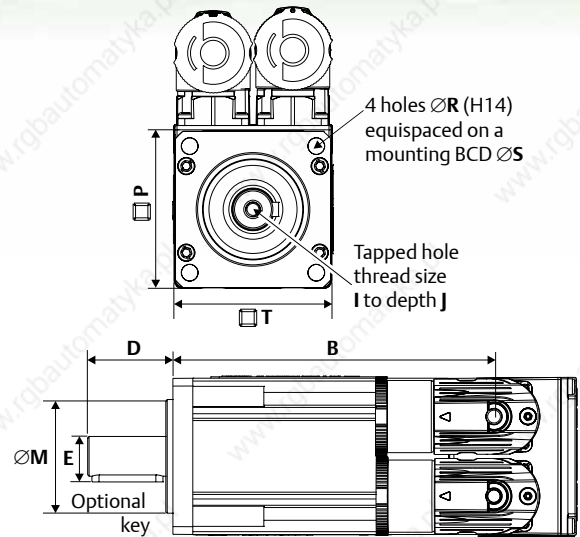

Motor Dimensions		Frame Length						
		A		B		C		
		(in)	(mm)	(in)	(mm)	(in)	(mm)	
Feedback AR, CR, EM, FM	Unbraked Length	A	4.65	118	5.59	142	6.54	166
		B	3.55	90	4.49	114	5.43	138
	Braked Length	A	6.22	158	7.17	182	8.11	206
		B	5.12	130	6.06	154	7.01	178
			(in)		(mm)			
Flange Thickness	K	0.276		7.0				
Register Length	L	0.098		2.5				
Register Diameter	M	1.58		40.0				
Overall Height	N	3.9		99.0				
Flange Square	P	2.17		55.0				
Mounting Hole Dia.	R	0.228		5.8				
Mounting Hole BCD	S	2.48		63.0				
Motor Housing	T	2.17		55.0				
Mounting Bolts		M5						
Shaft Dimensions			(in)		(mm)			
Shaft Diameter	C	0.551		14.0				
Shaft Length	D	1.18		30.0				
Key Height	E	0.63		16.0				
Key Length	F	0.98		25.0				
Key-to-Shaft End	G	0.059		1.5				
Key Width	H	0.197		5.0				
Tapped Hole Thread Size	I	M5 x 0.8						
Tapped Hole Depth	J	0.49		12.5				





# Unimotor HD 67mm Frame Ratings and Dimensions

Motor Frame Size (mm)	067ED			067UD		
	200-240			380-480		
Voltage (Vrms)						
Frame Length	A	B	C	A	B	C
Continuous Stall Torque (lb-in)	12.8	22.6	32.7	12.8	22.5	32.7
Continuous Stall Torque (Nm)	1.45	2.55	3.70	1.45	2.55	3.70
Peak Torque (lb-in)	38.5	67.7	98.2	38.5	67.7	98.2
Peak Torque (Nm)	4.35	7.65	11.10	4.35	7.65	11.10
Inertia (lb-in-sec <sup>2</sup> )	0.00027	0.00047	0.00066	0.00027	0.00047	0.00066
Inertia (kgm <sup>2</sup> )	0.000030	0.000053	0.000075	0.000030	0.000053	0.000075
Motor Weight (lb)	4.40	5.72	7.04	4.41	5.73	7.05
Motor Weight (kg)	2.00	2.60	3.20	2.00	2.60	3.20
Number of Poles	10	10	10	10	10	10
Speed 3000 rpm Kt (lb-in/A) =	8.23			7.08	14.16	
Kt (Nm/A) =	0.93			0.80	1.60	
Ke (V/krpm) =	57.0			49.0	98.0	
Rated Torque (lb-in)	12.4	21.7	31.0	12.4	21.7	31.0
Rated Torque (Nm)	1.40	2.45	3.50	1.40	2.45	3.50
Stall Current (A)	1.56	2.74	3.98	1.81	1.59	2.31
Rated Power (hp)	0.59	1.03	1.48	0.59	1.03	1.48
Rated Power (kW)	0.44	0.77	1.10	0.44	0.77	1.10
R (ph-ph) (Ω)	14.92	4.88	3.33	11.69	15.20	10.70
L (ph-ph) (mH)	45.43	17.40	12.70	35.18	54.20	40.80
Speed 6000 rpm Kt (lb-in/A) =	4.16			7.08		
Kt (Nm/A) =	0.47			0.80		
Ke (V/krpm) =	28.5			49.0		
Rated Torque (lb-in)	11.5	19.5		11.5	19.5	27.4
Rated Torque (Nm)	1.30	2.20		1.30	2.20	3.10
Stall Current (A)	3.12	5.48		1.81	3.19	4.63
Rated Power (hp)	1.10	1.85		1.10	1.85	2.61
Rated Power (kW)	0.82	1.38		0.82	1.38	1.95
R (ph-ph) (Ω)	3.86	1.22		11.69	3.79	2.68
L (ph-ph) (mH)	11.06	4.35		35.18	13.60	10.20

### NOTES:

- Δt = 212 °F (100 °C) winding 104 °F (40 °C) maximum ambient; all data subject to +/- 10% tolerance
- Stall torque, rated torque and power relate to maximum continuous operation tested in a 68 °F (20 °C) ambient above 12kHz drive switching frequency
- Maximum intermittent winding temperature is 284 °F (140 °C)

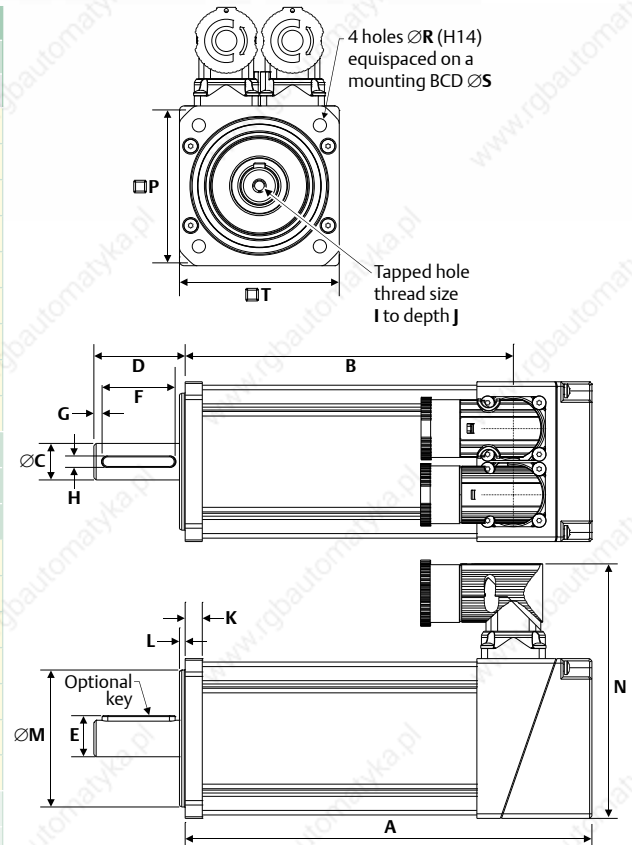

Motor Dimensions		Frame Length						
		A		B		C		
Feedback AR, CR, EM, FM	Unbraked Length	A (in)	A (mm)	B (in)	B (mm)	C (in)	C (mm)	
	Unbraked Length	A	5.62	142.7	6.80	172.7	7.98	202.7
	Braked Length	A	4.28	108.8	5.46	138.8	6.65	168.8
	Braked Length	A	7.00	177.7	8.18	207.7	9.37	237.7
	Braked Length	B	5.66	143.8	6.84	173.8	8.02	203.8
			(in)		(mm)			
	Flange Thickness	K	0.295		7.5			
	Register Length	L	0.098		2.5			
	Register Diameter	M	2.36		60.0			
	Overall Height	N	4.39		111.5			
	Flange Square	P	2.76		70.0			
	Mounting Hole Dia.	R	0.228		5.8			
	Mounting Hole BCD	S	2.95		75.0			
	Motor Housing	T	2.64		67.0			
	Mounting Bolts		M5					
Shaft Dimensions			(in)		(mm)			
	Shaft Diameter	C	0.551		14.0			
	Shaft Length	D	1.18		30.0			
	Key Height	E	0.63		16.0			
	Key Length	F	0.87		22.0			
	Key-to-Shaft End	G	0.142		3.6			
	Key Width	H	0.197		5.0			
	Tapped Hole Thread Size	I	M5 x 0.8					
	Tapped Hole Depth	J	0.53		13.5			

# Unimotor HD 89mm Frame Ratings and Dimensions

Motor Frame Size (mm)	089ED			089UD		
	200-240			380-480		
Voltage (Vrms)						
Frame Length	A	B	C	A	B	C
Continuous Stall Torque (lb-in)	28.3	48.7	70.8	28.3	48.7	70.8
Continuous Stall Torque (Nm)	3.20	5.50	8.00	3.20	5.50	8.00
Peak Torque (lb-in)	85.0	146.0	212.4	85.0	146.0	212.4
Peak Torque (Nm)	9.60	16.50	24.00	9.60	16.50	24.00
Inertia (lb-in-sec <sup>2</sup> )	0.00077	0.00142	0.00207	0.00077	0.00142	0.00207
Inertia (kgm <sup>2</sup> )	0.000087	0.000161	0.000234	0.000087	0.000161	0.000234
Motor Weight (lb)	6.8	9.2	11.7	6.8	9.2	11.7
Motor Weight (kg)	3.30	4.40	5.50	3.30	4.40	5.50
Number of Poles	10	10	10	10	10	10
Speed 3000 rpm Kt (lb-in/A) =	8.2			14.2		
Kt (Nm/A) =	0.93			1.60		
Ke (V/krpm) =	57.0			98.0		
Rated Torque (lb-in)	42.9	61.1	26.6	42.9	61.1	61.1
Rated Torque (Nm)	4.85	6.90	3.00	4.85	6.90	6.90
Stall Current (A)	5.91	8.60	2.00	5.91	8.60	8.60
Rated Power (hp)	2.04	2.91	1.26	2.04	2.91	2.91
Rated Power (kW)	1.52	2.17	0.94	1.52	2.17	2.17
R (ph-ph) (Ω)	1.57	0.89	10.10	1.57	0.89	2.68
L (ph-ph) (mH)	11.84	7.09	65.17	11.84	7.09	21.72
Speed 4000 rpm Kt (lb-in/A) =	6.2			10.6		
Kt (Nm/A) =	0.70			1.20		
Ke (V/krpm) =	42.8			73.5		
Rated Torque (lb-in)	25.7	40.3	56.2	25.7	40.3	56.2
Rated Torque (Nm)	2.90	4.55	6.35	2.90	4.55	6.35
Stall Current (A)	4.57	7.86	11.43	4.57	7.86	11.43
Rated Power (hp)	1.62	2.56	3.57	1.62	2.56	3.57
Rated Power (kW)	1.21	1.91	2.66	1.21	1.91	2.66
R (ph-ph) (Ω)	2.04	0.79	6.16	2.04	0.79	1.75
L (ph-ph) (mH)	13.20	5.97	39.78	13.20	5.97	14.03
Speed 6000 rpm Kt (lb-in/A) =	4.2			7.1		
Kt (Nm/A) =	0.47			0.80		
Ke (V/krpm) =	28.5			49.0		
Rated Torque (lb-in)	23.5	33.6	44.3	23.5	33.6	44.3
Rated Torque (Nm)	2.65	3.80	5.00	2.65	3.80	5.00
Stall Current (A)	6.88	11.83	17.20	6.88	11.83	17.20
Rated Power (hp)	2.24	3.21	4.21	2.24	3.21	4.21
Rated Power (kW)	1.67	2.39	3.14	1.67	2.39	3.14
R (ph-ph) (Ω)	0.98	0.39	2.52	0.98	0.39	0.83
L (ph-ph) (mH)	6.24	2.96	16.29	6.24	2.96	6.66

## NOTES:

- Δt= 212 °F (100 °C) winding 104 °F (40 °C) maximum ambient; all data subject to +/-10% tolerance
- Stall torque, rated torque and power relate to maximum continuous operation tested in a 68 °F (20 °C) ambient above 12kHz drive switching frequency
- Maximum intermittent winding temperature is 284 °F (140 °C)

\* Motor length increases 0.472in (12mm) for feedback options FB, EB, CA, SA and RA; motor length decreases 0.394in (10mm) for feedback option AE

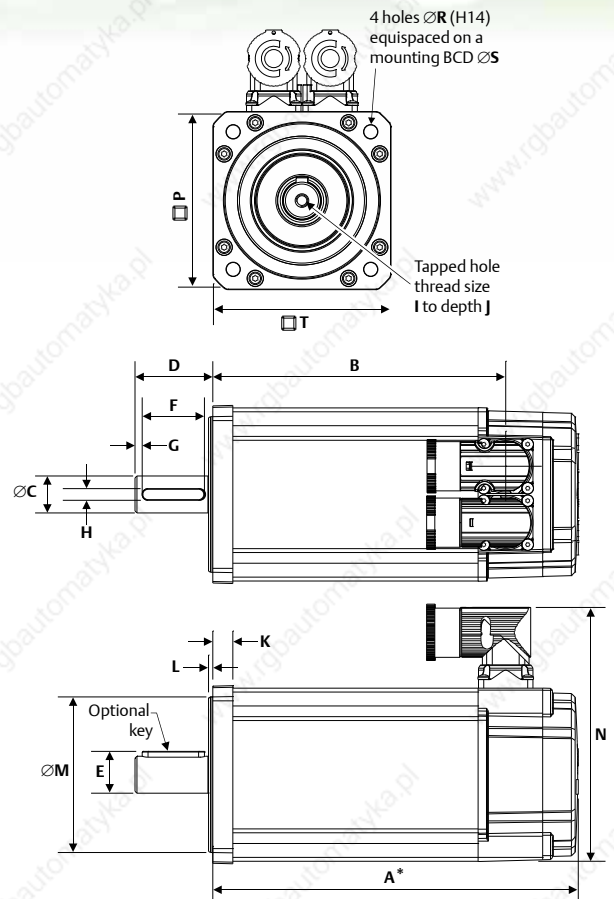

Motor Dimensions		Frame Length						
		A		B		C		
		(in)	(mm)	(in)	(mm)	(in)	(mm)	
Feedback EC and FC only*	Unbraked Length	A*	5.82	147.8	7.00	177.8	8.16	207.8
		B	4.35	110.5	5.53	140.5	6.71	170.5
	Braked Length	A*	7.40	187.9	8.58	217.9	9.76	247.9
		B	5.93	150.6	7.11	180.6	8.29	210.6
		(in)		(mm)				
Flange Thickness	K	0.406		10.3				
Register Length	L	0.087		2.2				
Register Diameter	M	3.15		80.0				
Overall Height	N	5.14		130.5				
Flange Square	P	3.58		91.0				
Mounting Hole Dia.	R	0.276		7.0				
Mounting Hole BCD	S	3.94		100.0				
Motor Housing	T	3.50		89.0				
Mounting Bolts		M6						
Shaft Dimensions		(in)		(mm)				
Shaft Diameter	C	0.75		19.0				
Shaft Length	D	1.57		40.0				
Key Height	E	0.85		21.5				
Key Length	F	1.26		32.0				
Key-to-Shaft End	G	0.147		3.7				
Key Width	H	0.236		6.0				
Tapped Hole Thread Size	I	M6 x 1.0						
Tapped Hole Depth	J	0.67		17.0				

# Unimotor HD 115mm Frame Ratings and Dimensions

Motor Frame Size (mm)	115ED			115UD		
Voltage (Vrms)	200-240			380-480		
Frame Length	B	C	D	B	C	D
Continuous Stall Torque (lb-in)	90.3	129.2	166.4	90.3	129.2	166.4
Continuous Stall Torque (Nm)	10.20	14.60	18.80	10.20	14.60	18.80
Peak Torque (lb-in)	270.8	387.6	499.1	270.8	387.6	499.1
Peak Torque (Nm)	30.60	43.80	56.40	30.60	43.80	56.40
Inertia (lb-in-sec <sup>2</sup> )	0.00390	0.00566	0.00742	0.00391	0.00566	0.00742
Inertia (kgm <sup>2</sup> )	0.000441	0.000639	0.000838	0.000441	0.000639	0.000838
Motor Weight (lb)	15.87	19.62	23.6	15.87	19.62	23.6
Motor Weight (kg)	7.20	8.90	10.70	7.20	8.90	10.70
Number of Poles	10	10	10	10	10	10
Speed 2000 rpm Kt (lb-in/A) =	12.4			21.2		
Kt (Nm/A) =	1.40			2.40		
Ke (V/krpm) =	85.5			147.0		
Rated Torque (lb-in)	76.1	105.3	138.1	76.1	105.3	138.1
Rated Torque (Nm)	8.60	11.90	15.60	8.60	11.90	15.60
Stall Current (A)	7.29	10.43	13.43	4.25	6.08	7.83
Rated Power (hp)	2.41	3.34	4.39	2.41	3.34	4.38
Rated Power (kW)	1.80	2.49	3.27	1.80	2.49	3.27
R (ph-ph) (Ω)	1.40	0.77	0.61	4.41	2.41	1.80
L (ph-ph) (mH)	12.84	7.87	6.62	40.59	24.69	19.45
Speed 3000 rpm Kt (lb-in/A) =	8.2			14.2		
Kt (Nm/A) =	0.93			1.60		
Ke (V/krpm) =	57.0			98.0		
Rated Torque (lb-in)	68.2	92.9		68.2	92.9	120.4
Rated Torque (Nm)	7.70	10.50		7.70	10.50	13.60
Stall Current (A)	10.97	15.70		6.38	9.13	11.75
Rated Power (hp)	3.25	4.43		3.25	4.43	5.73
Rated Power (kW)	2.42	3.30		2.42	3.30	4.27
R (ph-ph) (Ω)	0.58	0.39		1.83	1.21	0.78
L (ph-ph) (mH)	5.40	4.01		16.93	12.72	8.65

**NOTES:**

- Δt= 212 °F (100 °C) winding 104 °F (40 °C) maximum ambient; all data subject to +/-10% tolerance
- Stall torque, rated torque and power relate to maximum continuous operation tested in a 68 °F (20 °C) ambient above 12kHz drive switching frequency
- Maximum intermittent winding temperature is 284 °F (140 °C)

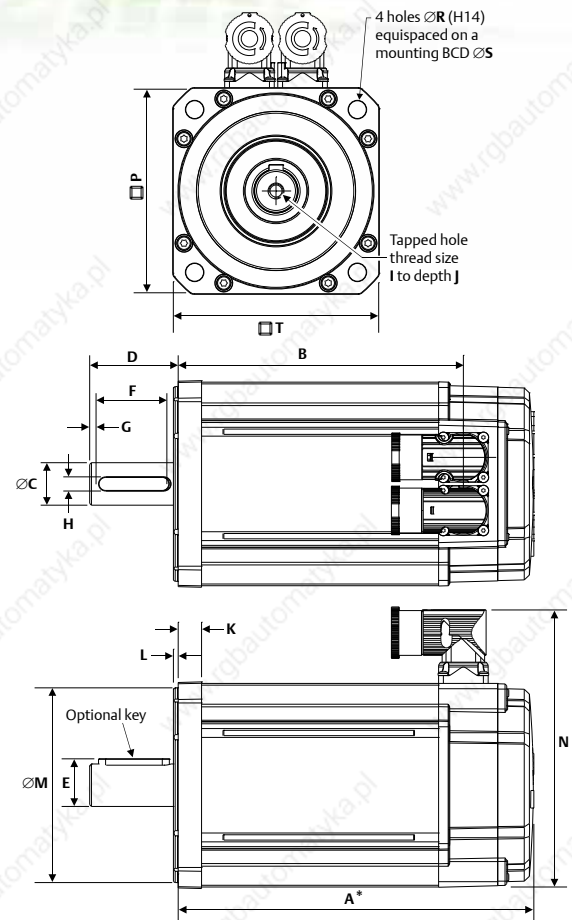

Motor Dimensions		Frame Length							
		B		C		D			
		(in)	(mm)	(in)	(mm)	(in)	(mm)		
Feedback EC and FC only*	Unbraked Length	A*	7.63	193.8	8.81	223.8	9.99	253.8	
		B	6.06	154.0	7.24	184.0	8.43	214.0	
	Braked Length	A*	9.09	230.9	10.27	260.9	11.45	290.9	
		B	7.52	191.1	8.70	221.1	9.89	251.1	
		(in)		(mm)					
Flange Thickness		K	0.519		13.2				
Register Length		L	0.106		2.7				
Register Diameter		M	4.33		110.0				
Overall Height		N	6.16		156.5				
Flange Square		P	4.57		116.0				
Mounting Hole Dia.		R	0.394		10.0				
Mounting Hole BCD		S	5.12		130.0				
Motor Housing		T	4.53		115.0				
Mounting Bolts		M8							
<b>Shaft Dimensions</b>		(in)		(mm)					
Shaft Diameter		C	0.945		24.0				
Shaft Length		D	1.97		50.0				
Key Height		E	1.06		27.0				
Key Length		F	1.57		40.0				
Key-to-Shaft End		G	0.209		5.3				
Key Width		H	0.315		8.0				
Tapped Hole Thread Size		I	M8 x 1.25						
Tapped Hole Depth		J	0.79		20.0				

\* Motor length increases 0.472in (12mm) for feedback options FB, EB, CA, SA and RA; motor length decreases 0.394in (10mm) for feedback option AE



# Unimotor HD 142mm Frame Ratings and Dimensions

Motor Frame Size (mm)	142ED			142UD		
	200-240			380-480		
Voltage (Vrms)						
Frame Length	C	D	E	C	D	E
Continuous Stall Torque (lb-in)	221.3	278.8	336.3	221.3	278.8	336.3
Continuous Stall Torque (Nm)	25.0	31.5	38.0	25.0	31.5	38.0
Peak Torque (lb-in)	662.9	836.4	1008.9	662.9	836.4	1008.9
Peak Torque (Nm)	74.9	94.5	114.0	74.9	94.5	114.0
Inertia (lb-in-sec <sup>2</sup> )	150.5	195.6	240.7	150.5	195.6	240.7
Inertia (kgm <sup>2</sup> )	.0017	.00221	.00272	.0017	.00221	.00272
Motor Weight (lb)	25.4	33.1	40.8	25.4	33.1	40.8
Motor Weight (kg)	11.5	15.0	18.5	11.5	15.0	18.5
Number of Poles	10	10	10	10	10	10
Speed 1000 rpm Kt (lb-in/A) =	24.78					
Kt (Nm/A) =	2.8					
Ke (V/krpm) =	171.0					
Rated Torque (lb-in)	206.2	256.7	305.4			
Rated Torque (Nm)	23.3	29.0	34.5			
Stall Current (A)	8.9	11.2	13.6			
Rated Power (hp)	3.27	4.08	4.84			
Rated Power (kW)	2.44	3.04	3.61			
R (ph-ph) (Ω)	1.36	0.94	0.72			
L (ph-ph) (mH)	21.34	15.17	12.3			
Connector Type	B					
Speed 1500 rpm Kt (lb-in/A) =				28.32		
Kt (Nm/A) =				3.2		
Ke (V/krpm) =				196.0		
Rated Torque (lb-in)				197.4	238.9	280.6
Rated Torque (Nm)				22.3	27.0	31.7
Stall Current (A)				7.8	9.8	11.9
Rated Power (hp)				4.69	5.63	6.71
Rated Power (kW)				3.5	4.2	5.0
R (ph-ph) (Ω)				1.36	0.94	0.72
L (ph-ph) (mH)				21.34	15.17	12.3
Connector Type				B		
Speed 2000 rpm Kt (lb-in/A) =	12.39			21.24		
Kt (Nm/A) =	1.4			2.4		
Ke (V/krpm) =	85.5			147.0		
Rated Torque (lb-in)	189.4	227.5	261.9	189.4	227.5	261.9
Rated Torque (Nm)	21.4	25.7	29.6	21.4	25.7	29.6
Stall Current (A)	17.8	22.5	27.1	10.4	13.1	15.8
Rated Power (hp)	6.01	7.21	8.31	6.01	7.21	8.31
Rated Power (kW)	4.48	5.38	6.2	4.48	5.38	6.2
R (ph-ph) (Ω)	0.34	0.24	0.18	0.79	0.62	0.49
L (ph-ph) (mH)	5.33	3.79	3.07	12.15	9.66	8.34
Connector Type	J			B		
Speed 3000 rpm Kt (lb-in/A) =	8.23			14.16		
Kt (Nm/A) =	0.93			1.6		
Ke (V/krpm) =	57.0			98.0		
Rated Torque (lb-in)	162.8	184.9		162.8	184.9	203.6
Rated Torque (Nm)	18.4	20.9		18.4	20.9	23.0
Stall Current (A)	26.9	33.9		15.6	19.7	23.8
Rated Power (hp)	7.75	8.81		7.75	8.81	9.70
Rated Power (kW)	5.78	6.57		5.78	6.57	7.23
R (ph-ph) (Ω)	0.12	0.10		0.34	0.24	0.18
L (ph-ph) (mH)	1.90	1.57		5.33	3.79	3.07
Connector Type	J			B	J	J

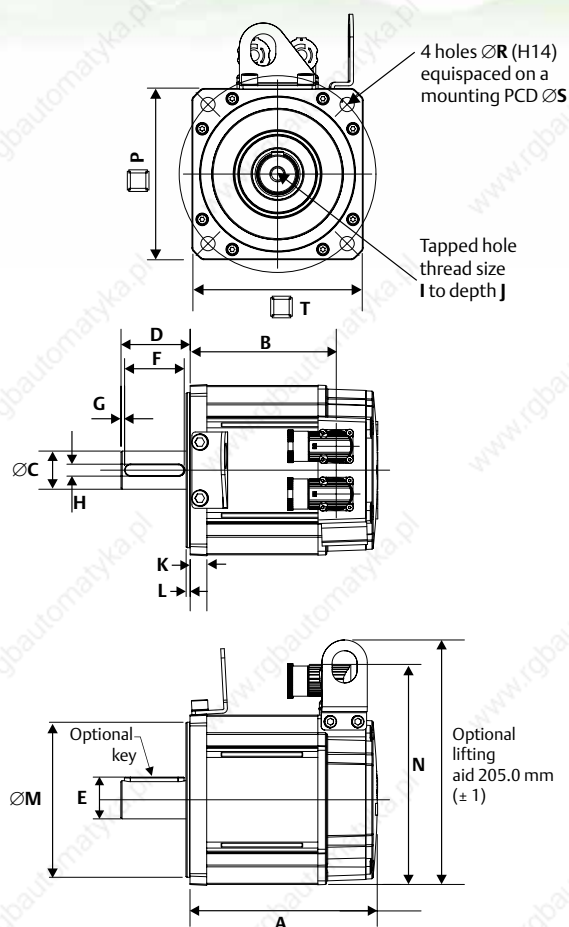

Motor Dimensions		Frame Length					
		C		D		E	
		(in)	(mm)	(in)	(mm)	(in)	(mm)
Unbraked Length	A	8.54	217.0	9.72	247.0	10.91	277.0
	B	7.19	182.5	8.37	212.5	9.55	242.5
Braked Length	A	11.12	282.5	12.30	312.5	13.48	342.5
	B	9.76	248.0	10.94	278.0	12.13	308.0
Flange Thickness	K	0.55		14.00			
Register Length	L	0.13		3.40			
Register Diameter	M	5.12		130.0			
Overall Height	N			183.5/204.5*			
Flange Square	P	5.59		142.0			
Mounting Hole Dia.	R	0.47		12.0			
Mounting Hole BCD	S	6.50		165.0			
Motor Housing	T	5.59		142.0			
Mounting Bolts		M10					
Shaft Dimensions		(in)		(mm)			
Shaft Diameter	C	1.26		32.0			
Shaft Length	D	2.28		58.0			
Key Height	E	1.38		35.0			
Key Length	F	1.97		50.0			
Key-to-Shaft End	G	0.118		3.0			
Key Width	H	0.394		10.0			
Tapped Hole Thread Size	I	M12 x 1.75					
Tapped Hole Depth	J	1.14		29.0			

# Unimotor HD 190mm Frame Ratings and Dimensions

Motor Frame Size (mm)	190ED			190UD		
	200-240			380-480		
Voltage (Vrms)						
Frame Length	C	D	F	C	D	F
Continuous Stall Torque (lb-in)	460.2	548.7	752.3	460.2	548.7	752.3
Continuous Stall Torque (Nm)	52.0	62.0	85.0	52.0	62.0	85.0
Peak Torque (lb-in)	1380.7	1646.2	2256.9	1380.7	1646.2	2256.9
Peak Torque (Nm)	156.0	186.0	255.0	156.0	186.0	255.0
Inertia (lb-in-sec <sup>2</sup> )	483.3	627.5	916.1	483.3	627.5	916.1
Inertia (kgm <sup>2</sup> )	.00546	.00709	.001035	.00546	.00709	.001035
Motor Weight (lb)	51.8	66.1	85.5	51.8	66.1	85.5
Motor Weight (kg)	23.5	28.6	38.8	23.5	28.6	38.6
Number of Poles	10	10	10	10	10	10
Speed 1000 rpm Kt (lb-in/A) =	24.78					
Kt (Nm/A) =	2.8					
Ke (V/krpm) =	171					
Rated Torque (lb-in)	433.7	500.1	685.9			
Rated Torque (Nm)	49.0	56.5	77.5			
Stall Current (A)	18.6	22.1	30.4			
Rated Power (hp)	6.88	7.94	10.89			
Rated Power (kW)	5.13	5.92	8.12			
R (ph-ph) (Ω)	0.47	0.4	0.23			
L (ph-ph) (mH)	12.3	10.4	6.79			
Speed 1500 rpm Kt (lb-in/A) =				28.32		
Kt (Nm/A) =				3.2		
Ke (V/krpm) =				196.0		
Rated Torque (lb-in)				408.9	462.0	606.3
Rated Torque (Nm)				46.2	52.2	68.5
Stall Current (A)				16.3	19.4	26.6
Rated Power (hp)				9.74	11.00	14.43
Rated Power (kW)				7.26	8.2	10.76
R (ph-ph) (Ω)				0.47	0.4	0.23
L (ph-ph) (mH)				12.3	10.4	6.79
Speed 2000 rpm Kt (lb-in/A) =	12.39			21.24		
Kt (Nm/A) =	1.4			2.4		
Ke (V/krpm) =	85.5			147		
Rated Torque (lb-in)	376.2			376.2		
Rated Torque (Nm)	42.5			42.5		
Stall Current (A)	37.1			21.7		
Rated Power (hp)	11.9			11.9		
Rated Power (kW)	8.9			8.9		
R (ph-ph) (Ω)	0.12			0.34		
L (ph-ph) (mH)	3.07			8.2		

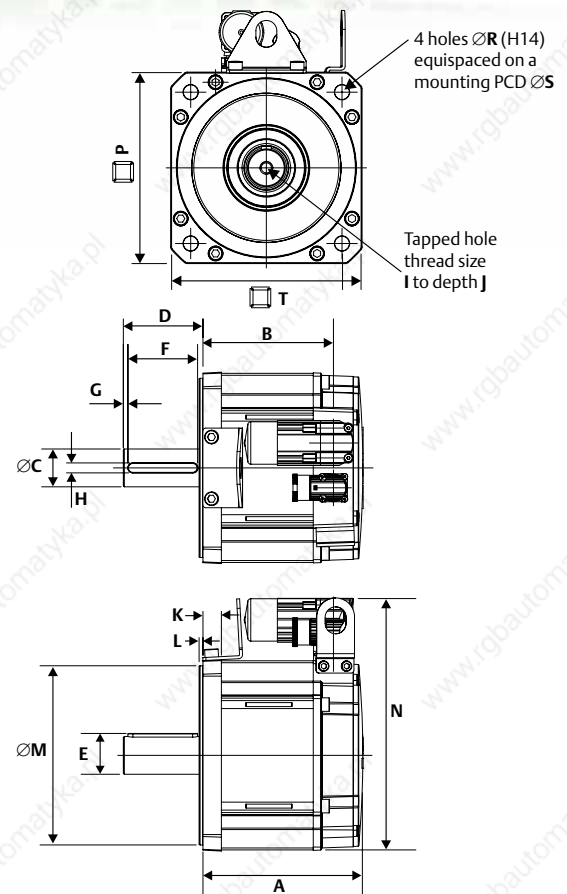

Motor Dimensions		Frame Length					
		C		D		F	
		(in)	(mm)	(in)	(mm)	(in)	(mm)
Unbraked Length	A	8.69	220.6	9.87	250.6	12.23	310.6
	B	7.52	191.1	8.70	221.1	9.89	251.1
Braked Length	A	12.56	319.1	13.74	349.1	16.11	409.1
	B	11.40	289.6	12.58	319.6	14.94	379.6
Flange Thickness	K	(in)		(mm)			
Register Length	L	0.73		18.5			
Register Diameter	M	0.15		3.9			
Overall Height	N	7.09		180.0			
Flange Square	P	9.94		252.5			
Mounting Hole Dia.	R	7.48		190.3			
Mounting Hole BCD	S	0.57		14.5			
Motor Housing	T	8.46		215.0			
Mounting Bolts		7.48		190.0			
		M12					
<b>Shaft Dimensions</b>		(in)		(mm)			
Shaft Diameter	C	1.50		38.0			
Shaft Length	D	3.15		80.0			
Key Height	E	1.61		41.0			
Key Length	F	2.76		70.0			
Key-to-Shaft End	G	0.181		4.6			
Key Width	H	0.394		10.0			
Tapped Hole Thread Size	I	M12 x 1.75					
Tapped Hole Depth	J	1.14		29.0			

# Unimotor HD Selection Considerations

## Feedback Options

Feedback Device Order Code	Feedback Type	Encoder Supply Voltage	SinCos Cycles or Incremental Pulses per Revolution	Resolution Available to Position Loop <sup>1,2</sup>	Feedback Accuracy <sup>3</sup>
<b>055-067 Motors</b>					
AR	Resolver	7V rms Excitation 5kHz	1	Medium 16384 (14 bit)	Low +/- 600 arc sec
CR	Incremental encoder	5Vdc	4096	Medium 16384 (14 bit)	Medium +/- 150 arc sec
EM (Multi-Turn) FM (Single-Turn)	Inductive absolute encoder EnDat 2.1 (Heidenhain)	5Vdc	16	High 2.62 x 10 <sup>5</sup> (18 bits)	Medium +/- 480 arc sec
<b>089, 115, 142 and 190 Motors</b>					
AE	Resolver	6V rms Excitation 6kHz	1	Medium 16384 (14 bit)	Medium +/- 720 arc sec
CA	Incremental encoder	5Vdc	4096	Medium 16384 (14 bit)	High +/- 60 arc sec
EC (Multi-Turn) FC (Single-Turn)	Inductive absolute encoder EnDat 2.1 (Heidenhain)	7 - 10Vdc	32	Medium absolute position 524288 (19 bits)	Medium +/- 280 arc sec
RA (Multi-Turn) SA (Single-Turn)	SinCos optical encoder Hiperface (SICK Stegmann)	7 - 12Vdc	1024	Very high 1.04 x 10 <sup>6</sup> (20 bits)	High For SinCos integral non-linearity +/- 45 arc sec For SinCos differential non-linearity +/- 7 arc sec (total accuracy +/- 52 arc sec)
EB (Multi-Turn) FB (Single-Turn)	Optical absolute encoder EnDat 2.2 (Heidenhain)	3.6 - 14Vdc	2048	Very high 2.08 x 10 <sup>6</sup> (21 bits)	Very high +/- 20 arc sec (differential non-linearity +/- 1% signal period)

### NOTES:

<sup>1</sup> The sine and cosine outputs from the SinCos optical encoders are analog outputs; with Unidrive SP and Digitax ST, the resolutions quoted above are true when the encoder type is set to either SC Endat or SC Hiper, depending on the encoder

<sup>2</sup> The information is supplied by the feedback device manufacturer and relates to it as a standalone device; the values may change when mounted into the motor and connected to a drive

<sup>3</sup> The output from the resolver is an analog output; the resolution is determined by the analog-to-digital converter used; the value shown is when the resolver is used in conjunction with the SM-Resolver Option Module

## Motor Selection

### Motor Derating

Adverse operating conditions require that the motor performance be derated. These conditions include ambient temperature above 104 °F (40 °C), motor mounting position, drive switching frequency or a drive oversized for the motor.

### Ambient Temperatures

For ambient temperatures above 104 °F (40 °C), the torque must be derated using the following formula as a guideline for motors up to 3000 rpm. Consult factory for higher-speed motor derating information.

$$\text{New derated torque} = \frac{\text{Specified torque} \times \sqrt{1 - ((\text{ambient temperature} - 40) / 100)}}$$

\*Measured in °C

For example, with an ambient temperature of 169 °F (76 °C), the new derated torque will be 0.8 x specified torque.

### Drive Switching Frequency

Most drive current ratings are reduced at higher switching frequencies. See individual drive manuals for details.

See the table below for motor derating factors (these figures are for guidance only).

Switching Frequency	Motor Type/Frame					
	055	067	089	115	142	190
3kHz	0.92	0.93	0.89	0.89	0.83	0.90
4kHz	0.93	0.94	0.91	0.92	0.85	0.95
5/6kHz	0.95	0.95	0.95	0.96	0.88	1
8kHz	0.96	0.98	0.97	0.98	0.91	1
10/12/16kHz	1	1	1	1	1	1

### Mounting Arrangements

In general, motor torque should be derated if the motor mounting surface is heated from an external source such as a gearbox, the motor is connected to a poor thermal conductor, or the motor is mounted in a confined space with restricted air flow.



### Thermal Test Conditions

The performance data shown was recorded with an ambient temperature of 68 °F (20 °C) and the motor mounted on a thermally-isolated aluminum plate.

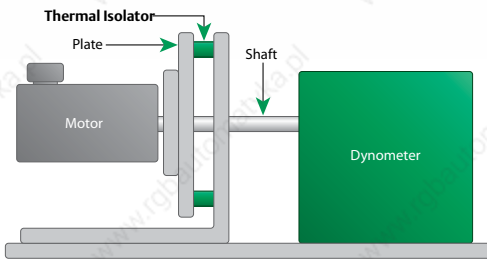

Motor Type/Frame	Aluminum Heatsink Plate	
	(in)	(mm)
055	4.3 x 4.3 x 1.06	110 x 110 x 27
067, 089	9.8 x 9.8 x 0.6	250 x 250 x 15
115 to 142	13.8 x 13.8 x 0.8	350 x 350 x 20
190	19.7 x 19.7 x 0.8	500 x 500 x 20

### Thermal Protection

Thermistor protection to 293 °F (145 °C) is built into the motor windings and gives an indication of serious overheating problems. *The installer must connect the thermistor to the drive. Failure to do so will invalidate the motor warranty if winding burns out.*

### Environmental Conditions

Any liquids or gases that may come into contact with the motor must be confirmed to ensure compliance with the correct international standards.

### 230V and 460V HD Motor Holding Brake Specifications

Motor Frame Size (mm)	Power Supply (Vdc)	Power (Watts)	Static Torque		Release Time (ms) nom.	Added Inertia		Backlash Degrees*	Added Weight	
			(lb-in)	(Nm)		(lb-in-sec <sup>2</sup> )	(kgcm <sup>2</sup> )		(lbs)	(kg)
055	24	6.3	15.9	1.8	22	0.00003	0.03	0.73	0.4	0.4
067	24	10.2	35.4	4	<50	0.00006	0.073	0.75	0.5	0.5
089	24	23.4	88.5	10	<50	0.00010	0.115	0.75	0.6	0.6
115	24	19.5	221	25	120	0.00029	0.327	0.75	1.2	1.2
142	24	25	371	42	95	0.00225	2.54	0.77	2.8	2.8
190 C-D	24	25	592	67	120	0.00404	4.57	0.77	5.3	5.3
190 F	24	54.5	885	100	CF	0.00683	7.72	0.75	5.3	5.3

**NOTES:**

- Figures shown in individual motor sections are at 68 °F (20 °C) ambient
- Apply a derate factor of 0.7 to standard brake torque figures if motor temperature is above 212 °F (100 °C)
- \*Backlash will increase over time



# NT Motor 230V

## Compact NEMA or Metric Flange Motors

The NT Motor is a compact, high-performance motor designed to maximize torque and minimize size. The NT Motor uses powerful Neodymium magnets and is manufactured with a segmented core to maximize stator efficiency.

NT Motors are available with direct motor-to-drive connector terminations for Control Techniques Epsilon EP, Unidrive SP and Digitax ST Servo drives – cable lengths up to 20ft are available.

### Key Features

- Torque range: 7.5 to 56lb-in (0.85 to 6.3Nm)
- Very low inertia for high acceleration and cycle rates
- Medium inertia options
- English (NEMA 23 or 34) or Metric (IEC- 72-1) flanges
- Available with or without holding brakes
- Direct connect available – no additional cables required!
- Flying-lead cabling option (ex: NTE-320-LONS-0000) with improved ingress protection; flying leads are available with or without MS connectors
- IP65 conformance (IP67S and IP68S optional)
- Standard 2048 optical encoder (absolute and resolver feedback available)
- Installed shaft seal are standard with all motors
- White epoxy food-grade finish option

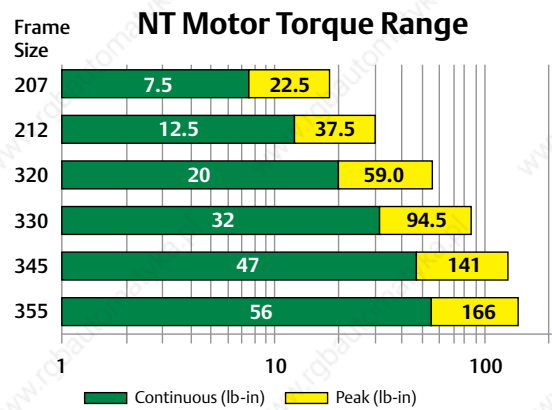

Use the information below to create an order code for an NT motor (top row is an example).

## NT Motor 230V Order Information

NT	E	2	07	T	B	N	S	DP	10
Motor	Mounting Flange	Frame Size (in)	Rated Torque (lb-in)	Lead Configuration	Brake (24V)	Feedback Device	Inertia	Feedback Cable Connectors / Optional Finish	Cable Length
NT	E=English	2 = 2"	2in frame	IP65	O = Unbraked	N = Incremental encoder 2048ppr	S = Low (std)	00 = Std configuration	00 = Std configuration
	M = Metric	3 = 3"	07 = 7.5	C = MS connector	B = Holding Brake	Lead Configuration E		Lead Configuration T	Lead Config L, T And F
		‡2 = 2in NEMA 23 ‡3 = 3in NEMA 34	12 = 12.5	L = Flying leads (no connectors)		R = Resolver**		DP = Flying lead with molded 15-pin feedback connector to Digitax ST, Unidrive SP and Epsilon EP	05 = 5ft leads 10 = 10ft leads 15 = 15ft leads
			20 = 20	T = MS style connector on flying leads		A = Inductive Absolute** EnDat 2.1 SinCos		Lead Configurations C, L, T, E, F	20 = 20ft leads
			30 = 32						
			45 = 47	IP67S					
			55 = 56	E = 90° circular Euro style				E0 = White epoxy food-grade finish applied to standard motor*	XX = Custom lengths available up to 20ft max. in 2ft increments
				IP68S					
				F = Flying lead and white epoxy food-grade finish					

### NOTES:

\*Include this code when ordering "F" type lead configuration

\*\*Not available on braked motors or metric flange

## Approvals



RoHS Compliant



# NT Motor 2-inch Frame Ratings and Dimensions

Motor Frame Size	2in	
Voltage	230Vrms	
Model	NT-207	NT-212
Continuous Stall Torque (lb-in)	7.5	12.5
Continuous Stall Torque (Nm)	0.85	1.4
Peak Torque (lb-in)	22.5	37.5
Peak Torque (Nm)	2.54	4.24
Standard Inertia (lb-in-sec <sup>2</sup> )	0.000094	0.000164
Standard Inertia (kgm <sup>2</sup> )	0.0000106	0.0000185
Maximum Cogging (lb-in)	0.094	0.12
Maximum Cogging (Nm)	0.011	0.014
Motor Weight (lbs)	3.0	4.0
Motor Weight (kg)	1.36	1.81
Rated Speed 5000 rpm Kt (Nm/A) =	5.12	5.08
Kt (Nm/A) =	0.58	0.57
Ke (V/krpm) =	35	34.7
Rated Torque (lb-in)	7.50	12.50
Rated Torque (Nm)	0.85	1.4
Stall Current (A)	1.7	2.7
Rated Power (kW)	0.432	0.740
R (ph-ph) (Ω)	11.1	4.56
L (ph-ph) (mH)	39.1	18.9

**NOTES:**

- Δt= 212 °F (100 °C) winding 104 °F (40 °C) maximum ambient; all data subject to +/-10% tolerance
- Stall torque, rated torque and power relate to maximum continuous operation above 10kHz drive switching frequency
- Maximum intermittent winding temperature is 284 °F (140 °C)

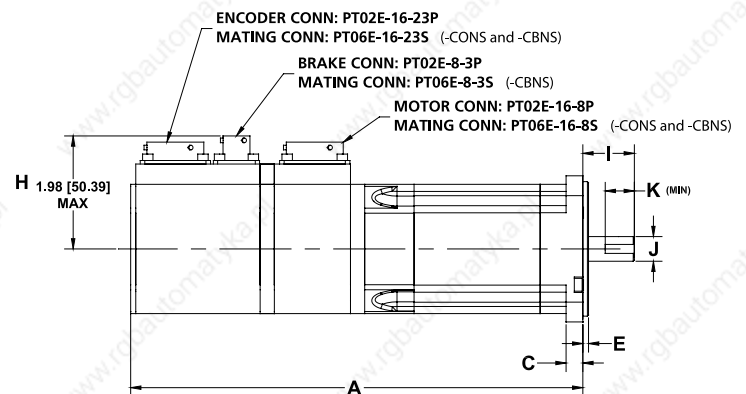
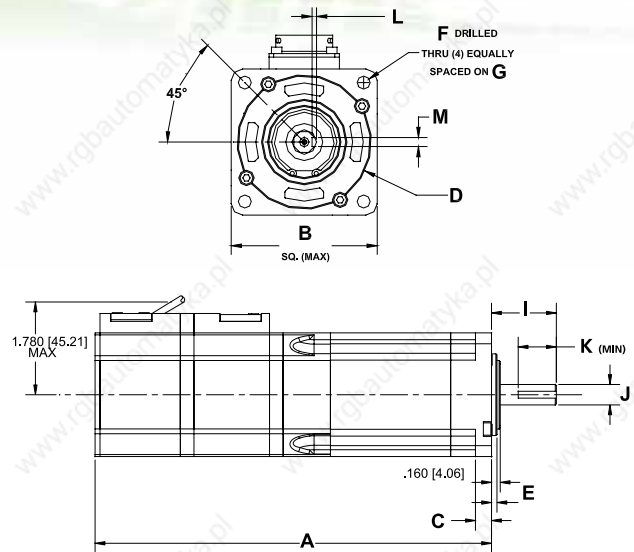

Motor Dimensions	English Flange				Metric Flange				
	NTE-207		NTE-212		NTM-207		NTM-212		
	(in)	(mm)	(in)	(mm)	(in)	(mm)	(in)	(mm)	
Length Overall — CONS/EONS*	5.55	141.0	6.55	166.4	5.55	141.0	6.55	166.4	
Length Overall — TONS/LONS/FONS	4.39	111.5	5.39	136.9	4.39	111.5	5.39	136.9	
Length Overall — CBNS/EBNS*	6.94	176.4	7.94	201.8	6.94	176.4	7.94	201.8	
Length Overall — TBNS/LBNS/FBNS	6.28	159.4	7.94	201.8	6.28	159.4	7.28	184.8	
Flange Square	B	2.27	57.7	2.27	57.7	2.57	65.2	2.57	65.2
Flange Thickness	C	0.29	7.5	0.29	7.5	0.29	7.5	0.29	7.5
Pilot Diameter	D	1.50	38.1	1.50	38.1	2.36	60.0	2.36	60.0
Pilot Thickness	E	0.10	2.5	0.10	2.5	0.10	2.5	0.10	2.5
Bolt Hole Diameter	F	0.21	5.2	0.21	5.2	0.23	5.8	0.23	5.8
Bolt Circle Diameter	G	2.63	66.7	2.63	66.7	2.95	75.0	2.95	75.0
Signal Connector Height — CONS	H	1.92	48.9	1.92	48.9	1.92	48.9	1.92	48.9
Signal Connector Height — TONS/LONS		1.78	45.2	1.78	45.2	1.78	45.2	1.78	45.2
Signal Connector Height — CBNS		1.98	50.4	1.98	50.4	1.98	50.4	1.98	50.4
Signal Connector Height — TBNS/LBNS		1.78	45.2	1.78	45.2	1.78	45.2	1.78	45.2
Shaft Length	I	1.21	30.7	1.21	30.7	0.93	23.5	0.93	23.5
Shaft Diameter	J	0.37	9.5	0.37	9.5	0.43	11.0	0.43	11.0
Shaft Key Dimensions					Shaft Key Dimensions				
Keyway Length (min)	K	0.70	17.8	0.70	17.8	0.51	13.0	0.51	13.0
Keyway Depth	L	0.08	2.0	0.08	2.0	0.08	2.1	0.08	2.1
Keyway Width	M	0.13	3.2	0.13	3.2	0.16	4.0	0.16	4.0

**NOTE:**

\*Not all variations are represented above; see our website for complete mechanical dimension drawings



# NT Motor 3-inch Frame Ratings and Dimensions

Motor Frame Size	3in			
	230Vrms			
Voltage	NT-320	NT-330	NT-345	NT-355
Continuous Stall Torque (lb-in)	19.7	31.5	47.5	55.5
Continuous Stall Torque (Nm)	2.2	3.56	5.31	6.27
Standard Inertia (lb-in-sec <sup>2</sup> )	0.000328	0.000438	0.000668	0.000888
Peak Torque (lb-in)	59.0	94.5	141.0	166.0
Peak Torque (Nm)	6.67	10.68	15.93	18.75
Standard Inertia (kgm <sup>2</sup> )	0.000037	0.000049	0.000075	0.000100
Medium Inertia (lb-in-sec <sup>2</sup> )	0.000558	0.000876	0.00146	
Medium Inertia (kgm <sup>2</sup> )	0.000063	0.000098	0.000164	
Maximum Cogging (lb-in)	0.18	0.315	0.47	0.555
Maximum Cogging (Nm)	0.020	0.036	0.053	0.063
Motor Weight (lbs)	6.0	7.3	10.0	12.3
Motor Weight (kg)	2.72	3.31	4.54	5.58
Rated Speed 3000 rpm Kt (lb-in/A) =			7.13	7.30
Kt (Nm/A) =			0.806	0.825
Ke (V/krpm) =			50.0	50.0
Rated Torque (lb-in)			47.0	55.5
Rated Torque (Nm)			5.31	6.27
Stall Current (A)			6.59	7.6
Rated Power (kW)			1.668	1.97
R (ph-ph) (Ω)			1.3	1.0
L (ph-ph) (mH)			17.0	13.0
Rated Speed 4000 rpm Kt (lb-in) =	3.50	5.04		
Kt (Nm/A) =	0.40	0.569		
Ke (V/krpm) =	29.0	36.0		
Rated Torque (lb-in)	16.0	31.6		
Rated Torque (Nm)	1.8	3.56		
Stall Current (A)	5.4	6.25		
Rated Power (kW)	0.757	1.49		
R (ph-ph) (Ω)	1.5	1.2		
L (ph-ph) (mH)	16.0	15.0		

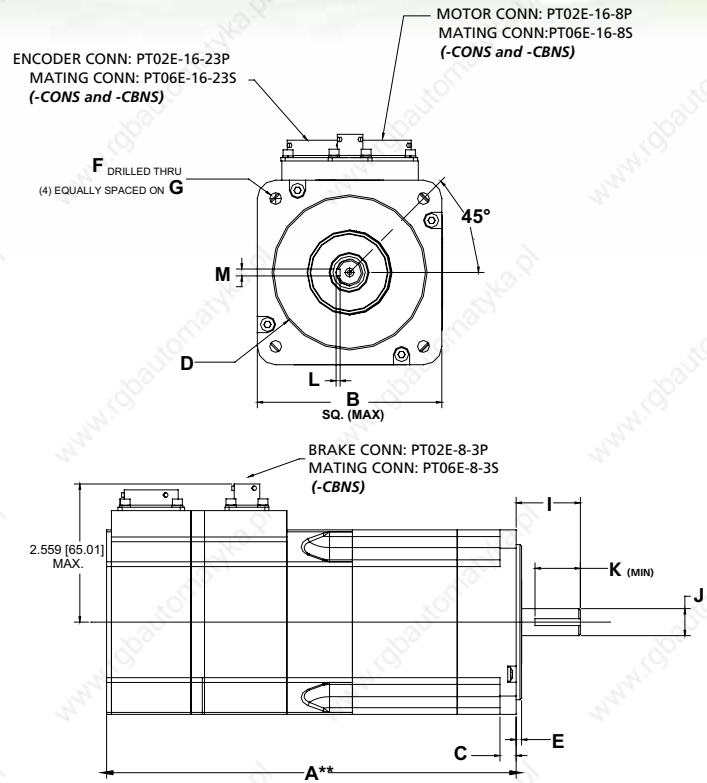

- NOTES:
- Δt = 212 °F (100 °C) winding 104 °F (40 °C) maximum ambient; all data subject to +/-10% tolerance
  - Stall torque, rated torque and power relate to maximum continuous operation above 10kHz drive switching frequency
  - Max. intermittent winding temperature is 284 °F (140 °C)

Motor Dimensions	English Flange								Metric Flange								
	NTE-320**		NTE-330**		NTE-345**		NTE-355		NTM-320**		NTM-330**		NTM-345**		NTM-355		
	(in)	(mm)	(in)	(mm)	(in)	(mm)	(in)	(mm)	(in)	(mm)	(in)	(mm)	(in)	(mm)	(in)	(mm)	
Length Overall — CONS/EONS*	5.22	132.5	5.82	147.8	7.02	178.3	9.42	239.2	5.22	132.5	5.82	147.8	7.02	178.3	9.42	239.2	
Length Overall — TONS/LONS/FONS	5.22	132.5	5.82	147.8	7.02	178.3	9.43	239.6	5.22	132.5	5.82	147.8	7.02	178.3	9.43	239.6	
Length Overall — CBNS/EBNS*	7.24	184.0	7.84	199.2	9.04	229.7	11.44	290.7	7.24	184.0	7.84	199.2	9.04	229.7	11.44	290.7	
Length Overall — TBNS/LBNS/FBNS	7.24	184.0	7.84	199.2	9.04	229.7	11.44	290.7	7.24	184.0	7.84	199.2	9.04	229.7	11.44	290.7	
Flange Square	B	3.42	86.9	3.42	86.9	3.42	86.9	3.42	86.9	3.42	86.9	3.42	86.9	3.42	86.9	3.42	86.9
Flange Thickness	C	0.30	7.6	0.30	7.6	0.30	7.6	0.30	7.6	0.30	7.6	0.30	7.6	0.30	7.6	0.30	7.6
Pilot Diameter	D	2.88	73.0	2.88	73.0	2.88	73.0	2.88	73.0	3.15	80.0	3.15	80.0	3.15	80.0	3.15	80.0
Pilot Thickness	E	0.10	2.5	0.10	2.5	0.10	2.5	0.10	2.5	0.12	3.0	0.12	3.0	0.12	3.0	0.12	3.0
Bolt Hole Diameter	F	0.22	5.6	0.22	5.6	0.22	5.6	0.22	5.6	0.28	7.0	0.28	7.0	0.28	7.0	0.28	7.0
Bolt Circle Diameter	G	3.88	98.4	3.88	98.4	3.88	98.4	3.88	98.4	3.94	100.0	3.94	100.0	3.94	100.0	3.94	100.0
Signal Connector Height — CONS		2.45	62.2	2.45	62.2	2.45	62.2	2.45	62.2	2.45	62.2	2.45	62.2	2.45	62.2	2.45	62.2
Signal Connector Height — TONS/LONS		2.35	59.7	2.35	59.7	2.35	59.7	2.35	59.7	2.35	59.7	2.35	59.7	2.35	59.7	2.35	59.7
Signal Connector Height — CBNS		2.56	65.0	2.56	65.0	2.56	65.0	2.56	65.0	2.56	65.0	2.56	65.0	2.56	65.0	2.56	65.0
Signal Connector Height — TBNS/LBNS		2.50	63.5	2.50	63.5	2.50	63.5	2.50	63.5	2.50	63.5	2.50	63.5	2.50	63.5	2.50	63.5
Shaft Length	I	1.21	30.7	1.21	30.7	1.21	30.7	1.21	30.7	1.21	30.7	1.21	30.7	1.21	30.7	1.21	30.7
Shaft Diameter	J	0.50	12.7	0.50	12.7	0.50	12.7	0.50	12.7	0.55	14.0	0.55	14.0	0.55	14.0	0.55	14.0
Shaft Key Dimensions								Shaft Key Dimensions									
Keyway Length (min)	K	0.84	21.3	0.84	21.3	0.84	21.3	0.84	21.3	0.79	20.0	0.79	20.0	0.79	20.0	0.79	20.0
Keyway Depth	L	0.08	2.0	0.08	2.0	0.08	2.0	0.08	2.0	0.10	2.6	0.10	2.6	0.10	2.6	0.10	2.6
Keyway Width	M	0.13	3.2	0.13	3.2	0.13	3.2	0.13	3.2	0.20	5.1	0.20	5.1	0.20	5.1	0.20	5.1

NOTES:  
 \*Not all variations are represented above; see our website for complete mechanical dimensional drawings  
 \*\*Motors are also available in medium inertia models with extended lengths; see website for dimensions

# NT Motor Flying Lead and Connector Details

**LBNS, LONS**

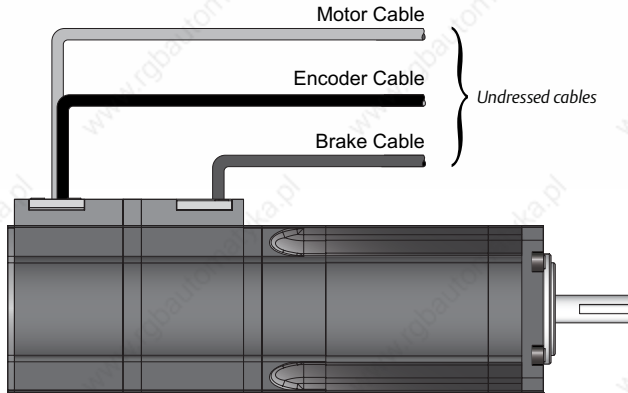

**FONS, FBNS**

Unbraked version shown

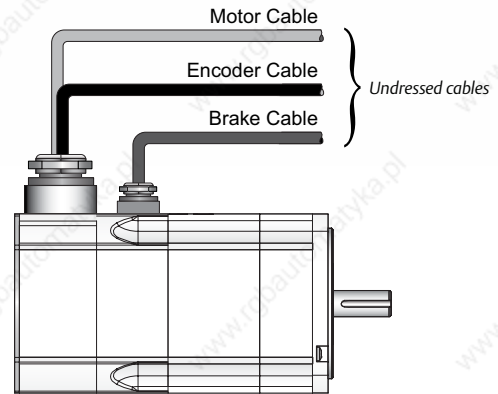

**TONS, TBNS**

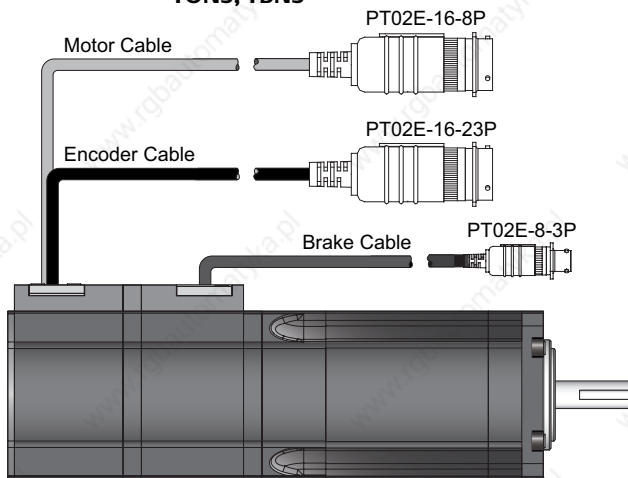

**EOxS**

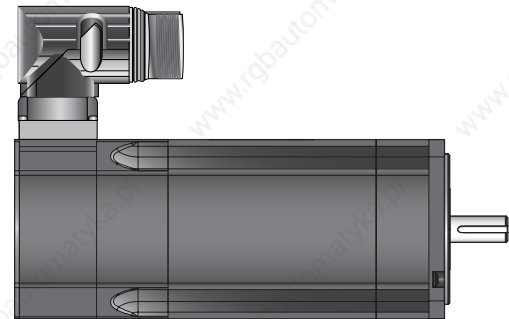

**TBNS-DP, TONS-DP**

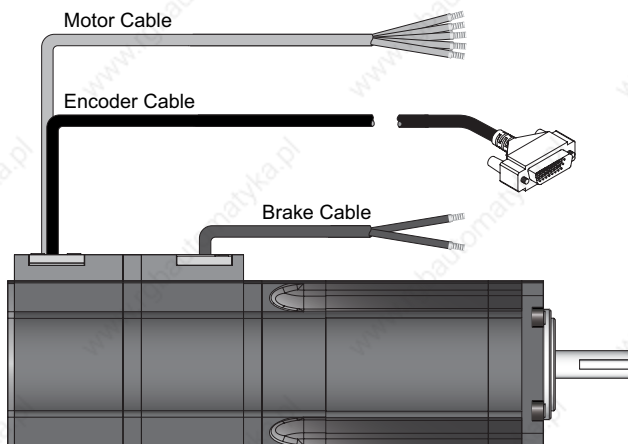

**CONS/CBNS**

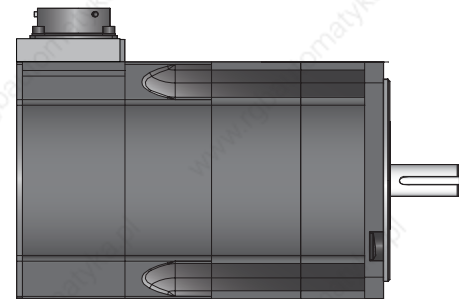

**NOTES:**

- Includes drive feedback connector terminations specifically for Epsilon EP, Unidrive SP and Digitax ST

# NT Motor Selection Considerations

## Feedback Options

Feedback Device Order Code	Feedback Type	Encoder Supply Voltage	SinCos or Incremental Pulses per Revolution	Resolution Available to Position Loop	Feedback Accuracy
-T_NS, -C_NS, -L_NS, -E_NS, -F_NS	Incremental Encoder	5Vdc	2048	16384 (14 bits)	±600 arc sec.
-EOAS	Inductive Absolute Encoder EnDat 2.1 (Heidenhain) Multi-Turn	5Vdc	16	262,000 (18 bits)	±480 arc sec.
-EORS	Resolver	7-10Vdc, 7Vrms Excitation 10kHz	1	16384 (14 bits)	±600 arc sec.

## Motor Selection

### Motor Derating

Any adverse operating conditions require that the motor performance be derated. These conditions include ambient temperature above 104 °F (40 °C), motor mounting position, drive switching frequency or a drive oversized for the motor.

### Drive Switching Frequency

Most drive current ratings are reduced at higher switching frequencies. See individual drive manuals for details.

### Mounting Arrangements

In general, motor torque should be derated if the motor mounting surface is heated from an external source such as a gearbox, the motor is connected to a poor thermal conductor, or the motor is mounted in a confined space with restricted air flow.

### Thermal Test Conditions

The performance data shown was recorded with an ambient temperature of 68 °F (20 °C) and the motor mounted on a thermally-isolated aluminum plate.

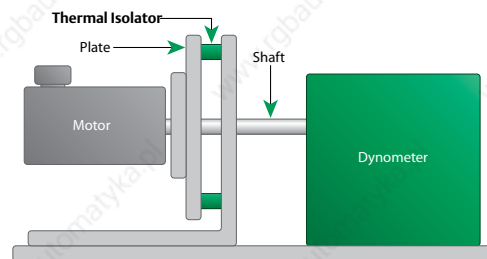

Motor Model	Frame Size	Mounting Plate Dimensions
NT	2"	6" x 6" x 1/4"
	3"	10" x 10" x 3/8"

### Thermal Protection

Thermistor protection to 284 °F (140 °C) is built into the motor windings and gives an indication of serious overheating problems. *The installer must connect the thermistor to the drive. Failure to do so will invalidate the motor warranty if winding burns out.*

### Environmental Conditions

Any liquids or gases that may come into contact with the motor must be confirmed to ensure compliance with the correct international standards.

### Ingress Protection

All NT Motors have shaft seals installed as standard. Standard models have an ingress rating (IP rating) of IP65. Lead configuration "E" models are rated IP67S. Configuration "F" models are rated IP 68S.

## NT Motor Holding Brake Specifications

Motor Frame Size (in)	Power Supply (Vdc)	Current (A)	Static Torque		Mechanical Disengage Time-Brake Release	Mechanical Engage Time-Brake Hold	Added Inertia	
			(lb-in)	(Nm)			(lb-in-sec <sup>2</sup> )	(kgm <sup>2</sup> )
2	24	0.33	20	2.26	28ms	14ms	0.000106	0.000012
3	24	0.65	88.5	10.0	43ms	13ms	0.000968	0.000109



# XV Motor 230V

## Economical Metric AC Servo Motor

The XV Servo motor series is a high-performance, low-inertia and high-torque motor in a compact economical package – ideal for high-volume applications. CE, UL and RoHS approved, XV Motors offer low-cost solutions with the features of a premium-priced servo offering.

Intended for higher throughputs and smaller machines, XV Motors are available in 4 frame sizes: 40, 60, 80 and 130mm with speeds ranging from 2000 to 5000rpm. Applications with continuous torque requirements up to 101lb-in (11.4Nm) are the perfect match for XV Motors.

XV Motors with 40, 60 and 90mm are fitted with AMP (Tyco® Mate-n-Lock™) connectors on 1-ft flying leads. (For added strain relief, these connectors can be snapped into place through holes in panels or brackets.)

### Key Features

- Torque range: 0.95 to 101lb-in (0.1 to 11.4Nm)
- Speed rating to 5000rpm
- Four frame sizes: 40, 60, 80 and 130mm
- CE, UL and RoHS approved
- Ambient operating temperature: 32 to 122 °F (0 to 40 °C)
- Atmosphere: no corrosive gas, flammable gas, oil mist or dust

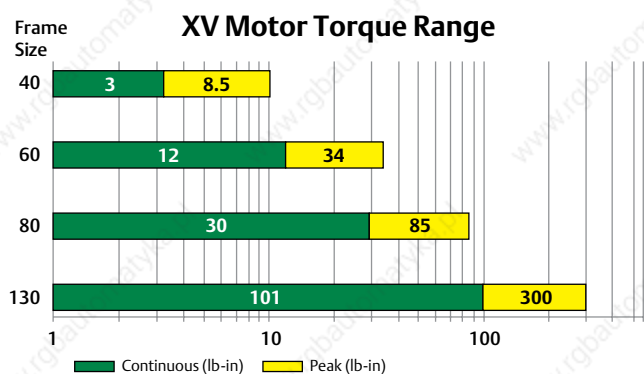

### Order Code

XVM	60	T	B	N	S	0000
Motor	Frame Size (mm)	Connections	Brake	Feedback Device	Inertia	Specials
XVM = 230V	40	C = MS connector	O = Unbraked	N = Incremental encoder 2048ppr	S = Std	Low voltage windings
	60	T = AMP connector on flying leads (40-80 frame)	B = 24V Holding Brake			
	80					
	130					

### Order Information

Frame (mm)	Rated Torque		Motor Only	Brake Motor
	(lb-in)	(Nm)	Order Code	
40	0.9	0.1	XVM-401-TONS-0000	XVM-401-TBNS-0000
40	1.4	0.16	XVM-402-TONS-0000	XVM-402-TBNS-0000
40	2.8	0.32	XVM-403-TONS-0000	XVM-403-TBNS-0000
60	2.8	0.32	XVM-604-TONS-0000	XVM-604-TBNS-0000
60	5.7	0.64	XVM-606-TONS-0000	XVM-606-TBNS-0000
60	11.24	1.27	XVM-6011-TONS-0000	XVM-6011-TBNS-0000
80	16.9	1.91	XVM-8017-TONS-0000	XVM-8017-TBNS-0000
80	22.6	2.55	XVM-8022-TONS-0000	XVM-8022-TBNS-0000
80	23.3	2.63	XVM-8023-TONS-0000	XVM-8023-TBNS-0000
80	28.1	3.18	XVM-8028-TONS-0000	XVM-8028-TBNS-0000
130	46.5	5.25	XVM-13046-CONS-0000	XVM-13046-CBNS-0000
130	50.7	5.73	XVM-13051-CONS-0000	XVM-13051-CBNS-0000
130	67.6	7.64	XVM-13068-CONS-0000	XVM-13068-CBNS-0000
130	88.8	10.03	XVM-13089-CONS-0000	XVM-13089-CBNS-0000
130	101.4	11.46	XVM-130101-CONS-0000	XVM-130101-CBNS-0000

### Approvals



RoHS Compliant



# XV Motor 40mm Frame Ratings and Dimensions

Motor Frame Size	40mm		
Voltage	230V		
Model	XVM-401	XVM-402	XVM-403
Continuous Stall Torque (lb-in)	0.95	1.4	2.8
Continuous Stall Torque (Nm)	0.11	0.16	0.32
Peak Stall Torque (lb-in)	2.4	4.5	7.7
Peak Stall Torque (Nm)	0.27	0.51	0.87
Standard Inertia (lb-in-sec <sup>2</sup> )	0.00001	0.00002	0.00004
Standard Inertia (kgm <sup>2</sup> )	0.000001	0.000002	0.000005
Maximum Cogging (lb-in) (typ.)	0.02	0.03	0.06
Maximum Cogging (Nm) (typ.)	0.002	0.003	0.007
Std Motor Weight Unbraked (Lbs)	0.7	0.88	1.1
Std Motor Weight Unbraked (Kg)	0.32	0.40	0.50
Rated Speed 3000 rpm Kt (lb-in/A) =	0.89	1.24	2.8
Max. Speed 5000 rpm Kt (Nm/A) =	0.101	0.140	0.32
Ke (V/krpm) =	7.8	10.6	12.7
Rated Torque (lb-in)	0.95	1.4	3.09
Rated Torque (Nm)	0.11	0.16	0.35
Stall Current (A)	1.07	1.20	1.38
Rated Power (kW)	0.034	0.050	0.110
R (ph-ph) (Ω)	11.69	9.4	6.89
L (ph-ph) (mH)	8.54	8.27	6.73

**NOTE:**

- The 40mm-frame XV Motor has a 1-ft cable terminated with a Tyco Mate-n-Lock connector

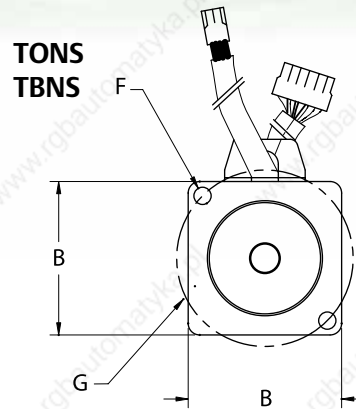

Flying lead length 1ft on 40mm, 60mm and 80mm

PLUG: AMP 172167-1 mating connector - Amp housing - 172159-1 pins - 170362-1

PLUG: AMP 172165-1 mating connector - Amp housing - 172157-1 pins - 170362-1

PLUG: AMP 172171-1 mating connector - Amp housing - 172163-1 pins - 170361-1

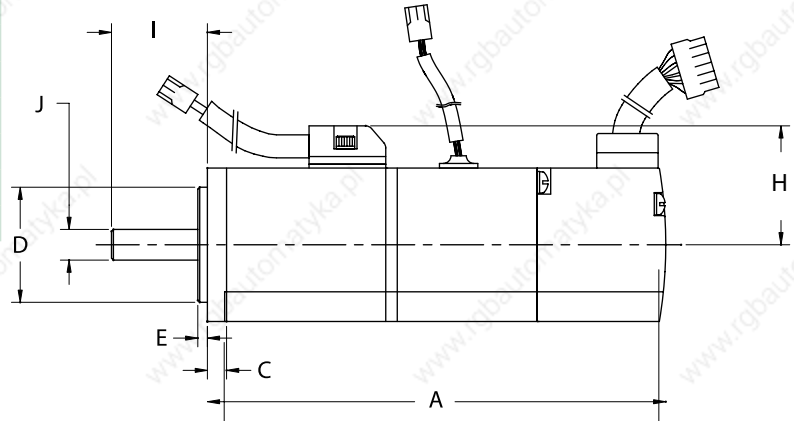

Dimensions	XVM-401		XVM-402		XVM-403		
	(in)	(mm)	(in)	(mm)	(in)	(mm)	
Length Overall – TONS/LONS (max)	A	2.98	76.0	3.27	83.0	3.92	99.5
Length Overall – TBNS/LBNS (max)		4.41	112.0	4.72	120.0	5.35	136.0
Flange Square	B	1.57	40.0	1.57	40.0	1.57	40.0
Flange Thickness	C	0.20	5.0	0.2	5.0	0.20	5.0
Pilot Diameter	D	1.18	30.0	1.18	30.0	1.18	30.0
Pilot Thickness	E	0.10	2.5	0.1	2.5	0.10	2.5
Bolt Hole Diameter	F	0.18	4.5	0.18	4.5	0.18	4.5
Bolt Circle Diameter	G	1.81	46.0	1.81	46.0	1.81	46.0
Signal Connector Height – TONS/LONS (max)	H	1.22	31.0	1.22	31.0	1.22	31.0
Signal Connector Height – TBNS/LBNS (max)		1.22	31.0	1.22	31.0	1.22	31.0
Shaft Length	I	0.98	25.0	0.98	25.0	0.98	25.0
Shaft Diameter	J	0.31	8.0	0.31	8.0	0.31	8.0

**NOTE:**

- All 40mm-frame XV Motors have smooth shafts

# XV Motor 60/80mm Frame Ratings and Dimensions

Motor Frame Size	60mm			80mm			
Voltage	230V						
Model	XVM-604	XVM-606	XVM-6011	XVM-8017	XVM-8022	XVM-8023	XVM-8028
Continuous Stall Torque (lb-in)	2.81	5.7	11.2	16.9	22.6	23.3	28.1
Continuous Stall Torque (Nm)	0.32	0.64	1.27	1.91	2.55	2.72	3.18
Peak Stall Torque (lb-in)	8.45	16.1	32.3	48.6	62.7	67.1	81.1
Peak Stall Torque (Nm)	0.95	1.82	3.65	5.49	7.08	7.58	9.16
Standard Inertia (lb-in-sec <sup>2</sup> )	0.00010	0.00016	0.00028	0.00096	0.001335	0.001335	0.001705
Standard Inertia (kgm <sup>2</sup> )	0.000011	0.000018	0.000032	0.00011	0.00015	0.00015	0.00019
Maximum Cogging (lb-in) (typ.)	0.06	0.11	0.24	0.18	0.23	0.24	0.28
Maximum Cogging (Nm) (typ.)	0.006	0.013	0.027	0.020	0.026	0.027	0.032
Std Motor Weight Unbraked (Lbs)	1.85	2.4	3.5	5.4	6.94	6.9	8.37
Std Motor Weight Unbraked (Kg)	0.84	1.09	1.59	2.45	3.15	3.14	3.80
Rated Speed 2000 rpm Kt (lb-in/A) =						6.32	
Max. Speed 3000 rpm Kt (Nm/A) =						0.714	
Ke (V/krpm) =						44.6	
Rated Torque (lb-in)						24.1	
Rated Torque (Nm)						2.72	
Stall Current (A)						3.82	
Rated Power (kW)						0.8556	
R (ph-ph) (Ω)						1.29	
L (ph-ph) (mH)						9.1	
Rated Speed 3000 rpm Kt (lb-in/A) =	1.82	3.76	4.15	5.0	5.04		5.5
Max. Speed 5000 rpm Kt (Nm/A) =	0.206	0.425	0.469	0.565	0.569		0.621
Ke (V/krpm) =	12.43	29.3	29.5	35.2	35.6		39.2
Rated Torque (lb-in)	2.81	6.13	12	17.9	22.6		28.1
Rated Torque (Nm)	0.32	0.69	1.27	2.02	2.55		3.18
Stall Current (A)	1.54	1.52	2.89	3.58	4.83		5.37
Rated Power (kW)	0.100	0.218	0.426	0.635	0.802		0.998
R (ph-ph) (Ω)	2.49	4.15	1.64	1.43	0.87		0.75
L (ph-ph) (mH)	7.37	15.21	7.32	9.2	5.9		5.04

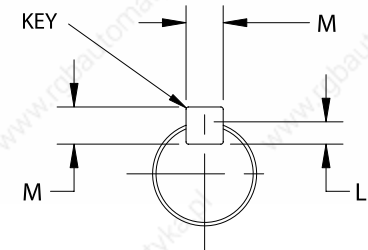

40mm motor has no keyway

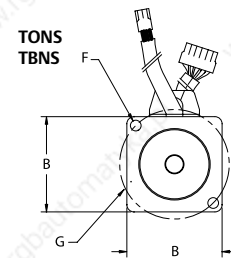

Flying lead length 1ft on 40mm, 60mm and 80mm

PLUG: AMP 172167-1 mating connector - Amp housing - 172159-1 pins - 170362-1  
 PLUG: AMP 172165-1 mating connector - Amp housing - 172157-1 pins - 170362-1  
 PLUG: AMP 172171-1 mating connector - Amp housing - 172163-1 pins - 170361-1

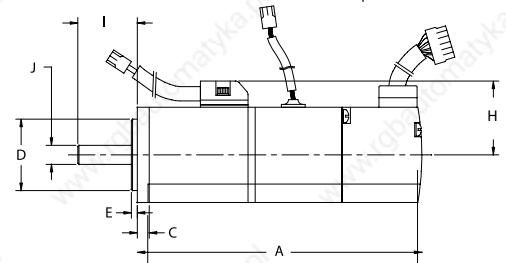

**NOTE:**

- The 60mm and 80mm-frame XV Motors have a 1-ft cable terminated with a Tyco Mate-n-Lock connector

Dimensions	XVM-604		XVM-606		XVM-6011		XVM-8017		XVM-8022 XVM-8023		XVM-8028		
	(in)	(mm)	(in)	(mm)	(in)	(mm)	(in)	(mm)	(in)	(mm)	(in)	(mm)	
Length Overall — TONS/LONS (max)	3.64	92.5	4.17	106.0	5.28	134.0	5.43	138.0	6.22	158.0	7.01	178.0	
Length Overall — TBNS/LBNS (max)	5.14	130	5.75	146.0	6.85	174.0	7.01	178.0	7.80	198.0	8.58	218.0	
Flange Square	2.44	62	2.44	62.0	2.44	62.0	3.15	80.0	3.15	80.0	3.15	80.0	
Flange Thickness	C	0.24	6	0.24	6.0	0.24	6.0	0.43	11.0	0.43	11.0	0.43	11.0
Pilot Diameter	D	1.97	50	1.97	50.0	1.97	50.0	2.76	70.0	2.76	70.0	2.76	70.0
Pilot Thickness	E	0.12	3	0.12	3.0	0.12	3.0	0.12	3.0	0.12	3.0	0.12	3.00
Bolt Hole Diameter	F	0.24	6	0.24	6.0	0.24	6.0	0.26	6.60	0.26	6.6	0.26	6.60
Bolt Circle Diameter	G	2.76	70	2.76	70.0	2.76	70.0	3.54	90.0	3.54	90.0	3.54	90.0
Signal Connector Ht. — TONS/LONS (max)	H	1.73	44	1.73	44.0	1.73	44.0	2.09	53.0	2.09	53.0	2.09	53.0
Signal Connector Ht. — TBNS/LBNS (max)	H	1.73	44	1.73	44.0	1.73	44.0	2.09	53.0	2.09	53.0	2.09	53.0
Shaft Length	I	1.18	30	1.18	30.0	1.18	30.0	1.57	40.0	1.57	40.0	1.57	40.0
Shaft Diameter	J	0.55	14	0.55	14.0	0.55	14.0	0.63	16.0	0.63	16.0	0.63	16.0
<b>Shaft Key Dimensions</b>													
Keyway Length (min)	K	0.89	22.5	0.89	22.5	0.89	22.5	1.18	30.0	1.18	30.0	1.18	30.0
Keyway Depth	L	0.12	3	0.12	3.0	0.12	3.0	0.12	3.0	0.12	3.0	0.12	3.0
Keyway Width	M	0.197	5	0.197	5.0	0.197	5.0	0.20	5.0	0.20	5.0	0.20	5.0

**NOTE:**

- All 40mm-frame XV Motors have smooth shafts



# XV Motor 130mm Frame Ratings and Dimensions

Motor Frame Size	130mm				
Voltage	230V				
Model	XVM-13046	XVM-13051	XVM-13068	XVM-13089	XVM-130101
Continuous Stall Torque (lb-in)	46.5	50.7	67.6	88.8	101.4
Continuous Stall Torque (Nm)	5.25	5.73	7.64	10.03	11.46
Peak Stall Torque (lb-in)	137	147.8	199.2	260.4	296.4
Peak Stall Torque (Nm)	15.48	16.70	22.51	29.42	33.49
Standard Inertia (lb-in-sec <sup>2</sup> )	0.01061	0.01061	0.01535	0.01535	0.02001
Standard Inertia (kgm <sup>2</sup> )	0.00120	0.00120	0.00173	0.00173	0.00226
Maximum Cogging (lb-in) (typ.)	0.47	0.51	0.68	0.89	1.01
Maximum Cogging (Nm) (typ.)	0.053	0.057	0.076	0.100	0.115
Std Motor Weight Unbraked (lbs)	15.86	15.8	19.1	21.3	22.47
Std Motor Weight Unbraked (kg)	7.21	7.18	8.68	9.68	10.21
Rated Speed 1000 rpm Kt (lb-in/A) =		12.57		13.45	13.6
Max. Speed 2000 rpm Kt (Nm/A) =		1.420		1.520	1.537
Ke (V/krpm) =		85.8		94.6	89.96
Rated Torque (lb-in)		50.7		88.76	101.4
Rated Torque (Nm)		5.73		10.03	11.46
Stall Current (A)		4.15		6.75	7.63
Rated Power (kW)		0.600		1.050	1.200
R (ph-ph) (Ω)		1.9		1.41	0.87
L (ph-ph) (mH)		20.1		15.99	10.67
Rated Speed 2000 rpm Kt (lb-in/A) =	7.5		7.4		
Max. Speed 3000 rpm Kt (Nm/A) =	0.847		0.836		
Ke (V/krpm) =	53.1		54.21		
Rated Torque (lb-in)	46.5		67.6		
Rated Torque (Nm)	5.25		7.64		
Stall Current (A)	6.28		9.23		
Rated Power (kW)	1.101		1.600		
R (ph-ph) (Ω)	0.77		0.47		
L (ph-ph) (mH)	7.76		5.3		

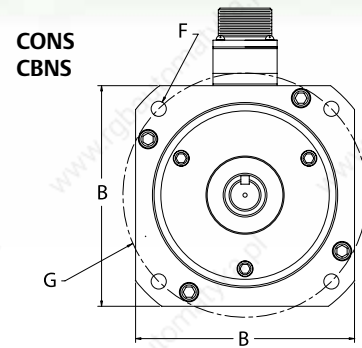

Connector standard: MS3102A20-4P  
Mating Connector: Amphenol MS3106A-20-4S  
Connector brake: MS3102A20-15P  
Mating Connector: Amphenol MS3106A-20-15S

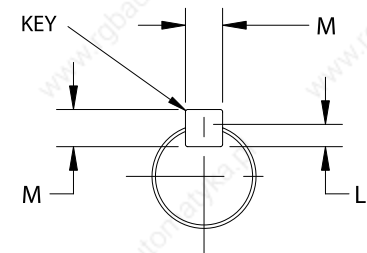
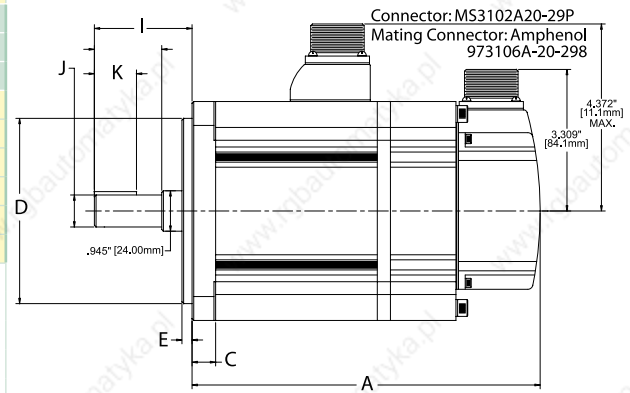

Dimensions		XVM-13046		XVM-13051		XVM-13068		XVM-13089		XVM-130101	
		(in)	(mm)	(in)	(mm)	(in)	(mm)	(in)	(mm)	(in)	(mm)
Length Overall — CONS (max)	A	6.61	168.0	6.61	168.0	7.56	192.0	7.56	192.0	8.50	216.0
Length Overall — CBNS (max)		8.11	206.0	8.11	206.0	9.06	230.0	9.06	230.0	10.0	254.0
Flange Square	B	5.12	130.0	5.12	130.0	5.12	130.0	5.12	130.0	5.12	130.0
Flange Thickness	C	0.55	14.0	0.55	14.0	0.55	14.0	0.55	14.0	0.55	14.0
Pilot Diameter	D	4.33	110.0	4.33	110.0	4.33	110.0	4.33	110.0	4.33	110.0
Pilot Thickness	E	0.24	6.0	0.24	6.0	0.24	6.0	0.24	6.0	0.24	6.0
Bolt Hole Diameter	F	0.35	9.0	0.35	9.0	0.35	9.0	0.35	9.0	0.35	9.0
Bolt Circle Diameter	G	5.71	145.0	5.71	145.0	5.71	145.0	5.71	145.0	5.71	145.0
Signal Connector Ht — Unbraked (max)	H	4.41	112.0	4.41	112.0	4.41	112.0	4.41	112.0	4.41	112.0
Signal Connector Ht — Braked (max)		4.41	112.0	4.41	112.0	4.41	112.0	4.41	112.0	4.41	112.0
Shaft Length	I	2.28	58.0	2.28	58.0	2.28	58.0	2.28	58.0	2.28	58.0
Shaft Diameter	J	0.75	19.0	0.75	19.0	0.87	22.0	0.87	22.0	0.87	22.0
<b>Shaft Key Dimensions</b>											
Keyway Length (min)	K	0.98	25.0	0.98	25.0	0.98	25.0	0.98	25.0	0.98	25.0
Keyway Depth	L	0.12	3.0	0.12	3.0	0.14	3.50	0.14	3.50	0.14	3.5
Keyway Width	M	0.20	5.0	0.20	5.0	0.24	6.0	0.24	6.0	0.24	6.0

# XV Motor Selection Considerations

## XV Motor Feedback – All Frame Sizes

XV Motors include a 5Vdc incremental encoder with 2048 pulses per revolution.

## Motor Selection

### Motor Derating

Any adverse operating conditions require that the motor performance be derated. These conditions include ambient temperature above 104 °F (40 °C), motor mounting position, drive switching frequency or a drive oversized for the motor.

### Ambient Temperatures

For ambient temperatures above 104 °F (40 °C), the torque must be derated.

### Mounting Arrangements

In general, motor torque should be derated if the motor mounting surface is heated from an external source such as a gearbox, the motor is connected to a poor thermal conductor, or the motor is mounted in a confined space with restricted air flow.

### Drive Switching Frequency

Most drive current ratings are reduced at higher switching frequencies. See individual drive manuals for details.

### Thermal Test Conditions

The performance data shown was recorded with an ambient temperature of 68 °F (20 °C) and the motor mounted on a thermally-isolated aluminum plate.

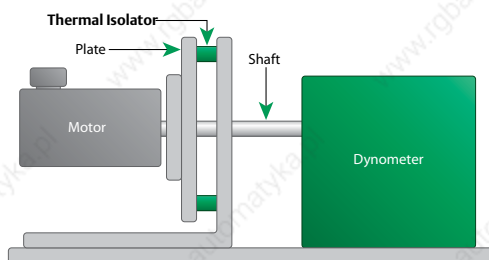

Motor Frame (mm)	Aluminum Heatsink Plate	
	(in)	(mm)
40	5.91 x 5.91 x 0.24	150 x 150 x 6
60	5.91 x 5.91 x 0.24	150 x 150 x 6
80	9.84 x 9.84 x 0.39	250 x 250 x 10
130	9.84 x 9.84 x 0.39	250 x 250 x 10

## Thermal Protection

The XV Motors do not have and are not offered with a winding thermal temperature sensor. Motor feedback cables have the Motor Temperature Sensor lines defeated (shorted between pin 14 (GND) and pin 15 (5V)). These cables include cable model numbers XUFTS-xxx and XUFCS-xxx (where -xxx is cable length in feet).

All Control Techniques Servo drives have a current-limiting algorithm in the firmware specifically to limit current levels. When properly matched and limited to the motor specifications, the drive firmware will fault the drive when the rated rms current of the motor is exceeded.

## Environmental Conditions

Any liquids or gases that may come into contact with the motor must be confirmed to ensure compliance with the correct international standards.

## Ingress Protection

Standard models have an ingress rating (IP rating) as listed in the table below.

Frame Size	IP rating	Exclusions
40mm	IP55*	Shaft through area of face plate and connectors
60mm	IP55*	Shaft through area of face plate and connectors
80mm	IP65*	Shaft through area of face plate and connectors
130mm	IP65*	Shaft through area of face plate

NOTE:

\* Shaft seal option is not available

## XV Motor Holding Brake Specifications

Motor Frame Size (mm)	Power Supply (Vdc)	Current (A)	Static Torque		Mechanical Engagement Time (ms)	Added Inertia		Added Weight (kg)
			(lb-in)	(Nm)		(lb-in-sec <sup>2</sup> )	(kgcm <sup>2</sup> )	
40	24	0.25	2.8	0.318	20	0.000023	0.003	0.2
60	24	0.27	13.0	1.47	50	0.000045	0.048	0.6
80	24	0.38	28.6	3.23	60	0.00011	0.125	0.7
130	24	0.29	70.8	8	40	0.000478	0.54	0.83

NOTES:

- Figures shown in individual motor sections are at 68 °F (20 °C) ambient
- Apply a derate factor of 0.7 to standard brake torque figures if motor temperature is above 212 °F (100 °C)

# Unimotor FM 230V / 460V

## Flexible Configuration, Medium-inertia Servo Motors

Unimotor FM is a high-performance, brushless AC Servo motor range matched for use with Control Techniques drives. “FM” stands for “flexible motor” and is designed to accommodate a wide range of applications. The motors are available in seven frame sizes with various mounting arrangements and motor lengths. Control Techniques motors and drives are designed to function as an optimized system. Unimotor FM is the perfect partner for Unidrive SP, Digitax ST and Epsilon EP Servo drives.

### Key Features

- Torque range: 6.4 to 648lb-in (0.72 to 73.2Nm)
- Optional high peak torque motors; up to 5 times stall torque
- Medium inertia design with high inertia option available
- Connector styles include vertical, 90° low profile and 90° rotatable
- Variety of flange possibilities (IEC/NEMA)
- Standard and high-energy dissipation brake options
- IP65 conformance
- Winding to suit 230V and 460V
- Speeds include 1500, 2000, 2500, 3000, 4000, 4500, 5000 and 6000rpm
- Multiple feedback options:
  - Resolver: robust for extreme applications and conditions – lower accuracy, medium resolution
  - Incremental encoder: high accuracy, medium resolution
  - Inductive absolute: medium accuracy, medium resolution, single-turn and multi-turns
  - Optical SinCos/absolute: high accuracy, high resolution, single-turn and multi-turn
  - Hiperface (SICK) and EnDAT (Heidenhain) protocols supported

### Approvals



## Unimotor

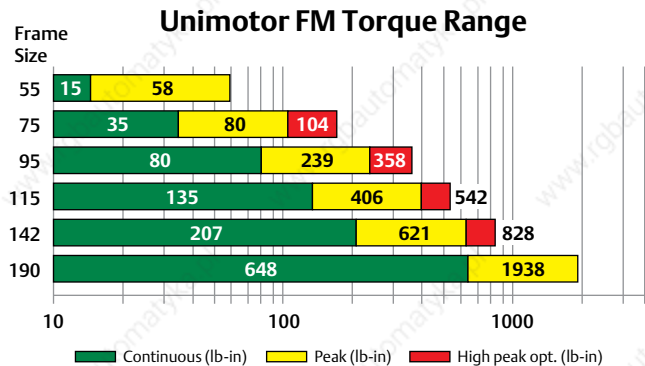

### Electronic Nameplate Capability



When a Control Techniques Servo drive is connected to a Unimotor FM fitted with a SinCos or absolute encoder, it can recognize and communicate with the motor to obtain the “electronic nameplate” data. This motor data can then be used to automatically optimize the drive settings. This feature simplifies commissioning and maintenance, ensures consistent performance and saves time.



# Unimotor FM Order Information

Use the information below to create an order code for a Unimotor FM (top row is an example).

95	U	2	B	30	5	B	A	CA	A	100	190
Frame Size	Motor Voltage	Peak Torque Selection	Stator Length	Winding Speed RPM	Holding Brake	Connection Type	Output Shaft	Feedback Device	Inertia	BCD**	Shaft Dia.
55	E = 230V	055 Frame	055 Frame	055 Frame	0 = Not fitted (Std)	B = Power and signal 90° rotatable (Std)	A = Key (Std)	AR = Resolver	A = Std.	063 Std	9.0 Opt
75	U = 460V	2 = Standard peak torque	075 Frame	30 = 3000	1 = Holding brake fitted 24Vdc	C = Power 90° rotatable and signal vertical	B = Plain Shaft	CR = Incremental encoder 4096 ppr*	075-190 Frame	070 Opt	11.0 A-C
95		075-142 Frame	A-D	60 = 6000	075-190 Frame	V = Power and signal vertical		MR = Incremental encoder 2048 ppr	A = Std.	075 Std	14.0 Max
115		2 = Standard peak torque	095-142 Frame	10 = 1000	0 = Not fitted (Std)	A = Power and signal 90° fixed		KR = Incremental encoder 1024 ppr	B = High Inertia	080 Opt	11.0 A
142		P = High peak torque	A-E	20 = 2000	1 = Holding brake fitted 24Vdc	B = Power and signal 90° rotatable		EM = Inductive Absolute Multi-Turn EQI 1130		085 Opt	14.0 B-D
190		190 Frame	A-F	30 = 3000	5 = High energy dissipation holding brake	C = Power 90° rotatable and signal vertical		FM = Inductive Absolute Single-Turn ECI 1118		095 Frame	19.0 Max
		2 = Standard peak torque		40 = 4000		V = Power and signal vertical (Std)		TL = Optical SinCos Multi-Turn SKM 36		100 Std	095 Frame
				60 = 6000				UL = Optical SinCos Single-Turn SKS 36		98' Opt	14.0 A
								075-142 Frame		115 Opt	19.0 B-E
								AE = Resolver		115 Std	115 Frame
								CA = Incremental encoder 4096 ppr*		130 Opt	19.0 A-C
								EB = Optical Absolute Multi-Turn EQN 1325		145 Opt	24.0 D-E
								FB = Optical Absolute Single-Turn ECN 1313		142 Frame	32.0 Max
								EC = Inductive Absolute Multi-Turn EQI 1331		165 Std	142 Frame
								FC = Inductive Absolute Single-Turn ECI 1319		149' Opt	24.0 A-E
								RA = Optical SinCos Multi-Turn SRM 50		190 Frame	32.0 Max
								SA = Optical SinCos Single-Turn SRS 50		215 Std	190 Frame
								190 Frame		† NEMA flange	
								AE = Resolver		32.0	A-H
								CA = Incremental encoder (Std for 190) 4096 ppr*		42.0	Max
								EB = Optical Absolute Multi-Turn EQN 1325			
								FB = Optical Absolute Single-Turn ECN 1313			
								RA = Optical SinCos Multi-Turn SRM 50			
								SA = Optical SinCos Single-Turn SRS 50			

## Stocked Motors

Unbraked Motors						
Stall Torque		Speed	230V	Stall	460V	Stall
(lb-in)	(Nm)	rpm	Order Code	Current (A)	Order Code	Current (A)
14.6	1.65	3000	055E2C300BACRA063110	1.81	055U2C300BACRA063110	1.0
14.6	1.65	6000	055E2C600BACRA063110	3.44		
19.5	2.2	3000	075E2B300BACAA075140	2.4	075U2B300BACAA075140	1.4
19.5	2.2	4000	075E2B400BACAA075140	3.1	075U2B400BACAA075140	1.9
34.5	3.9	3000			075U2D300BACAA075140	2.5
38.1	4.3	3000	095E2B300BACAA100190	4.7	095U2B300BACAA100190	2.7
38.1	4.3	4000	095E2B400BACAA100190	6.0	095U2B400BACAA100190	3.6
66.4	7.5	3000	095E2D300BACAA100190	8.1	095U2D300BACAA100190	4.7
66.4	7.5	4000	095E2D400BACAA100190	10.5		
79.7	9	4000			095U2E400BACAA100190	7.5
58.4	6.6	3000			115U2B300BACAA115190	4.2
83.2	9.4	3000	115E2C300BACAA115190	10.2	115U2c300bacaa115190	5.9
109.7	12.4	3000	115E2D300BACAA115240	13.4	115U2D300BACAA115240	7.8
135.4	15.3	3000	115E2E300BACAA115240	16.5	115U2E300BACAA115240	9.6
135.4	15.3	3000			142U2C300BACAA165240	9.6
175	19.8	3000			142U2D300BACAA165240	12.4
207.1	23.4	3000			142U2E300BACAA165240	14.7
363.7	41.1	3000			190U2D300BACAA215320	25.7

**NOTES:**

- \* Stocked motor standard feedback
- Stocked motors cover the range of FM motors and are available with short lead times for low quantities
- Consult factory for lead times for high-volume orders or on select feedback options
- Brake motors are not included in stock motor list

## Unimotor FM 55mm Frame Ratings

Motor Frame Size (mm)	055E2			055U2		
	230V			460V		
Voltage	230V			460V		
Frame Length	A	B	C	A	B	C
Continuous Stall Torque (lb-in)	6.37	10.4	14.6	6.37	10.4	14.6
Continuous Stall Torque (Nm)	0.72	1.18	1.65	0.72	1.18	1.65
Standard (2) Peak Torque Selection Max (lb-in)	25.5	41.8	58.4	25.4	41.7	58.4
Standard (2) Peak Torque Selection Max (Nm)	2.88	4.72	6.60	2.88	4.72	6.60
Standard Inertia (lb-in-sec <sup>2</sup> )	0.00009	0.00018	0.00027	0.00009	0.00018	0.00027
Standard Inertia (kgm <sup>2</sup> )	0.000012	0.000023	0.000034	0.000012	0.000023	0.000034
Winding Thermal Time Const. (s)	34.00	38.00	42.00	34.00	38.00	42.00
Motor Weight (lbs)	2.65	3.31	3.97	2.65	3.31	3.97
Motor Weight (kg)	1.20	1.50	1.80	1.20	1.50	1.80
Rated Speed 3000 rpm Kt (lb-in/A) =	6.55	7.70	8.05	6.55	13.19	14.60
Kt (Nm/A) =	0.74	0.87	0.91	0.74	1.49	1.65
Ke (V/krpm) =	45.00	52.50	55.00	45.00	90.00	100
Rated Torque (lb-in)	6.20	9.29	13.1	6.20	9.29	13.1
Rated Torque (Nm)	0.70	1.05	1.48	0.70	1.05	1.48
Stall Current (A)	0.97	1.36	1.81	0.97	0.79	1.00
Rated Power (kW)	0.22	0.33	0.46	0.22	0.33	0.46
R (ph-ph) (Ω)	28.00	14.10	9.50	28.00	45.00	31.00
L (ph-ph) (mH)	50.00	32.00	23.00	50.00	100.00	75.00
Rated Speed 6000 rpm Kt (lb-in/A) =	3.98	3.81	4.25	6.55	6.99	7.35
Kt (Nm/A) =	0.45	0.43	0.48	0.74	0.79	0.83
Ke (V/krpm) =	27.00	26.00	29.00	45	47.5	50
Rated Torque (lb-in)	6.02	7.97	10.6	6.02	7.97	10.6
Rated Torque (Nm)	0.68	0.90	1.20	0.68	0.9	1.20
Stall Current (A)	1.61	2.74	3.44	0.97	1.5	2.00
Rated Power (kW)	0.43	0.57	0.75	0.43	0.57	0.75
R (ph-ph) (Ω)	8.50	3.60	2.40	28.00	10.7	7.80
L (ph-ph) (mH)	16.00	8.20	6.30	50.00	25	20.00

### NOTES:

- $\Delta t = 212\text{ }^{\circ}\text{F}$  ( $100\text{ }^{\circ}\text{C}$ ) winding  $104\text{ }^{\circ}\text{F}$  ( $40\text{ }^{\circ}\text{C}$ ) maximum ambient
- All data subject to  $\pm 10\%$  tolerance
- Stall torque, rated torque and power relate to maximum continuous operation tested in a  $68\text{ }^{\circ}\text{F}$  ( $20\text{ }^{\circ}\text{C}$ ) ambient at 12kHz drive switching frequency
- Control Techniques has an ongoing process of development and reserves the right to change the specification without notice
- All other figures relate to a  $68\text{ }^{\circ}\text{F}$  ( $20\text{ }^{\circ}\text{C}$ ) motor temperature; maximum intermittent winding temperature is  $284\text{ }^{\circ}\text{F}$  ( $140\text{ }^{\circ}\text{C}$ )

### Matched Motor and Drive Combinations

Control Techniques motors and drives are designed to function as an optimized system. Unimotor FM is the perfect partner for Unidrive SP, Digitax ST and Epsilon EP Servo drives.



# Unimotor FM 55mm Frame Dimensions

**NOTE:** Output key dimensions (E, F, G and H) are applicable to keyed units only.

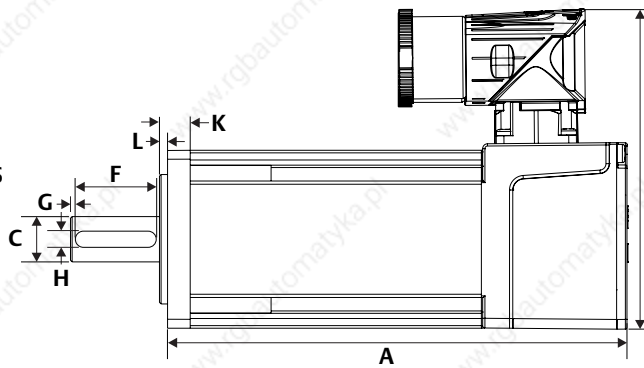
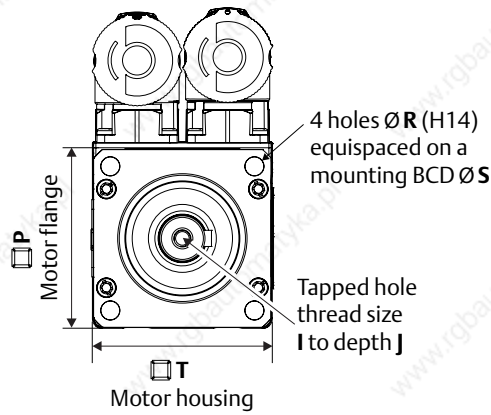
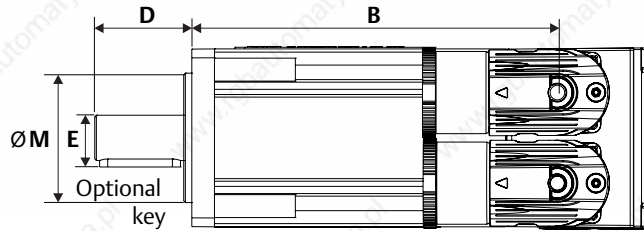

For vertical connectors, allow approximately 175.0mm clearance for mating cable

Motor Dimensions	Frame Length						
		A		B		C	
		(in)	(mm)	(in)	(mm)	(in)	(mm)
Unbraked Length	A	4.6	118.0	5.6	142.0	6.5	166.0
	B	3.5	90.0	4.5	114.0	5.4	138.0
Braked Length	A	6.2	158.0	7.2	182.0	8.1	206.0
	B	5.1	130.0	6.1	154.0	7.0	178.0
		(in)		(mm)			
Flange Thickness	K	0.3		7.0			
Register Length	L	0.1		2.5			
Register Diameter	M	1.6		40.0			
Flange Square	P	2.2		55.0			
Mounting Hole Dia.	R	0.2		5.8			
Mounting Hole BCD	S	2.5		63.0			
Motor Housing	T	2.2		55.0			
Mounting Bolts		M5					

Optional Flange Dimensions	BCD Code		
	070		
		(in)	(mm)
Front End Frame Type - Flat			
Flange Thickness	K	0.24	6.0
Register Length	L	0.12	3.0
Mounting Hole Dia.	M	1.97	50.0
Flange Square	P	2.36	60.0
Mounting Hole Dia.	R	0.22	5.5
Mounting Hole BCD	S	2.76	70.0
Mounting Bolts		M5	

Shaft Dimensions	9.0mm		11.0mm Std.		14.0mm Opt.		
	(in)	(mm)	(in)	(mm)	(in)	(mm)	
Shaft Diameter	C	0.35	9.0	0.43	11.0	0.55	14.0
Shaft Length	D <sup>1</sup>	0.79	20.0	0.91	23.0	1.18	30.0
Key Height	E <sup>2</sup>	0.40	10.2	0.49	12.5	0.63	16.0
Key Length	F <sup>3</sup>	0.59	15.0	0.59	15.0	0.98	25.0
Key-to-Shaft End	G <sup>4</sup>	0.04	1.0	0.06	1.5	0.06	1.5
Key Width	H	0.12	3.0	0.16	4.0	0.20	5.0
Tapped Hole Thread Size	I	M4 x 10.0		M4 x 10.0		M5 x 12.5	
Tapped Hole Depth	J <sup>5</sup>	0.39	10.0	0.39	10.0	0.49	12.5

<sup>1</sup>±0.45mm, <sup>2</sup>To IEC 72-1, <sup>3</sup>±0.25mm, <sup>4</sup>±1.1mm, <sup>5</sup>±0.4mm

Vertical Connectors Dimensions	Frame Length						
		A		B		C	
		(in)	(mm)	(in)	(mm)	(in)	(mm)
Unbraked Length	B1	2.95	75.0	3.90	99.0	4.84	123.0
	B2	3.27	83.0	4.21	107.0	5.16	131.0
Braked Length	B1	4.53	115.0	5.47	139.0	6.42	163.0
	B2	4.84	123.0	5.79	147.0	6.81	173.0
		(in)		(mm)			
Power Connector Height	N	4.09		104.0			
Signal Connector Height		3.66		93.0			

Optional Connector Height		
Connector Type	(in)	(mm)
"B"	3.9	99.0
"C"	3.8	96.0
"V"	4.1	105.0



# Unimotor FM 75mm Frame Ratings

Motor Frame Size (mm)	075E2				075U2			
	230V				460V			
Voltage								
Frame Length	A	B	C	D	A	B	C	D
Continuous Stall Torque (lb-in)	10.6	19.5	27.4	34.5	10.6	19.5	27.4	34.5
Continuous Stall Torque (Nm)	1.2	2.2	3.1	3.9	1.2	2.2	3.1	3.9
Standard (2) Peak Torque Selection Max (lb-in)	31.9	58.4	82.3	104	31.9	58.4	82.3	104
Standard (2) Peak Torque Selection Max (Nm)	3.6	6.6	9.3	11.7	3.6	6.6	9.3	11.7
High (P) Peak Torque Selection Max (lb-in)	53.1	97.4	137	173	53.1	97.3	137	173
High (P) Peak Torque Selection Max (Nm)	6.0	11.0	15.5	19.5	6.0	11.0	15.5	19.5
Standard Inertia (lb-in-sec <sup>2</sup> )	0.00062	0.00106	0.00142	0.00177	0.00062	0.00106	0.00142	0.00177
Standard Inertia (kgm <sup>2</sup> )	0.00007	0.00012	0.00016	0.00020	0.00007	0.00012	0.00016	0.00020
High Inertia (lb-in-sec <sup>2</sup> )	0.00097	0.00133	0.00177	0.00212	0.00097	0.00133	0.00177	0.00212
High Inertia (kgm <sup>2</sup> )	0.00011	0.00015	0.00020	0.00024	0.00011	0.00015	0.00020	0.00024
Winding Thermal Time Const. (s)	81.0	74.0	94.0	100.0	81.0	74.0	94.0	100.0
Motor Weight (lbs)	7.94	9.70	11.46	13.23	7.94	9.70	11.46	13.23
Motor Weight (kg)	3.6	4.4	5.2	6.0	3.6	4.4	5.2	6.0
Rated Speed 2000 rpm Kt (lb-in/A) =	12.4				21.24			
Kt (Nm/A) =	1.4				2.4			
Ke (V/krpm) =	85.5				147			
Rated Torque (lb-in)	9.74	18.6	26.6	33.6	9.74	18.6	26.6	33.6
Rated Torque (Nm)	1.1	2.1	3.0	3.8	1.1	2.1	3.0	3.8
Stall Current (A)	0.9	1.6	2.3	2.8	0.5	1	1.3	1.7
Rated Power (kW)	0.23	0.44	0.63	0.8	0.23	0.44	0.63	0.8
R (ph-ph) (Ω)	45.8	15.3	8.52	5.72	144	48.2	25.0	15.7
L (ph-ph) (mH)	74.1	34.71	21.5	16.16	214	99.2	59.2	44.7
Rated Speed 3000 rpm Kt (lb-in/A) =	8.23				14.16			
Kt(Nm/A) =	0.93				1.6			
Ke (V/krpm) =	57				98			
Rated Torque (lb-in)	9.74	17.7	24.8	31.0	9.74	17.7	24.8	31.0
Rated Torque (Nm)	1.1	2.0	2.8	3.5	1.1	2.0	2.8	3.5
Stall Current (A)	1.3	2.4	3.4	4.2	0.8	1.4	2.0	2.5
Rated Power (kW)	0.35	0.63	0.88	1.1	0.35	0.63	0.88	1.1
R (ph-ph) (Ω)	15.91	6.22	3.35	2.37	60.8	20.1	10.5	7.5
L (ph-ph) (mH)	30.33	14.74	9.54	7.08	98.4	41.8	27.6	19.7
Rated Speed 4000 rpm Kt (lb-in/A) =	6.37				10.62			
Kt (Nm/A) =	0.72				1.2			
Ke (V/krpm) =	44				73.5			
Rated Torque (lb-in)	8.85	15.1	20.4	25.7	8.85	15.1	20.4	25.7
Rated Torque (Nm)	1.0	1.7	2.3	2.9	1.0	1.7	2.3	2.9
Stall Current (A)	1.7	3.1	4.4	5.5	1.0	1.9	2.6	3.3
Rated Power (kW)	0.42	0.71	0.96	1.21	0.42	0.71	0.96	1.21
R (ph-ph) (Ω)	12.1	4.05	2.3	1.48	36.8	10.5	6.3	4.2
L (ph-ph) (mH)	19.6	8.88	5.85	4.2	54.9	24.8	14.9	10.8
Rated Speed 6000 rpm Kt (lb-in/A) =	4.16				7.08			
Kt (Nm/A) =	0.47				0.8			
Ke (V/krpm) =	28.5				49			
Rated Torque (lb-in)	7.97	14.2	18.6	23.0	7.97	14.2	18.6	23.0
Rated Torque (Nm)	0.9	1.6	2.1	2.6	0.9	1.6	2.1	2.6
Stall Current (A)	2.6	4.7	6.6	8.3	1.5	2.8	3.9	4.9
Rated Power (kW)	0.57	1.01	1.32	1.63	0.57	1.01	1.32	1.63
R (ph-ph) (Ω)	5.2	1.77	0.95	0.65	15.0	5.0	2.66	1.9
L (ph-ph) (mH)	8.3	3.7	3.1	1.86	24.0	10.6	6.8	4.8

**NOTES:**

- Δt = 212 °F (100 °C) winding 104 °F (40 °C) maximum ambient
- All data subject to ±10% tolerance
- Stall torque, rated torque and power relate to maximum continuous operation tested in a 68 °F (20 °C) ambient at 12kHz drive switching frequency
- Control Techniques has an ongoing process of development and reserves the right to change the specification without notice
- All other figures relate to a 68 °F (20 °C) motor temperature; maximum intermittent winding temperature is 284 °F (140 °C)

# Unimotor FM 75mm Frame Dimensions

**NOTE:** Output key dimensions (E,F,G and H) are applicable to keyed units only. 90° connectors are standard

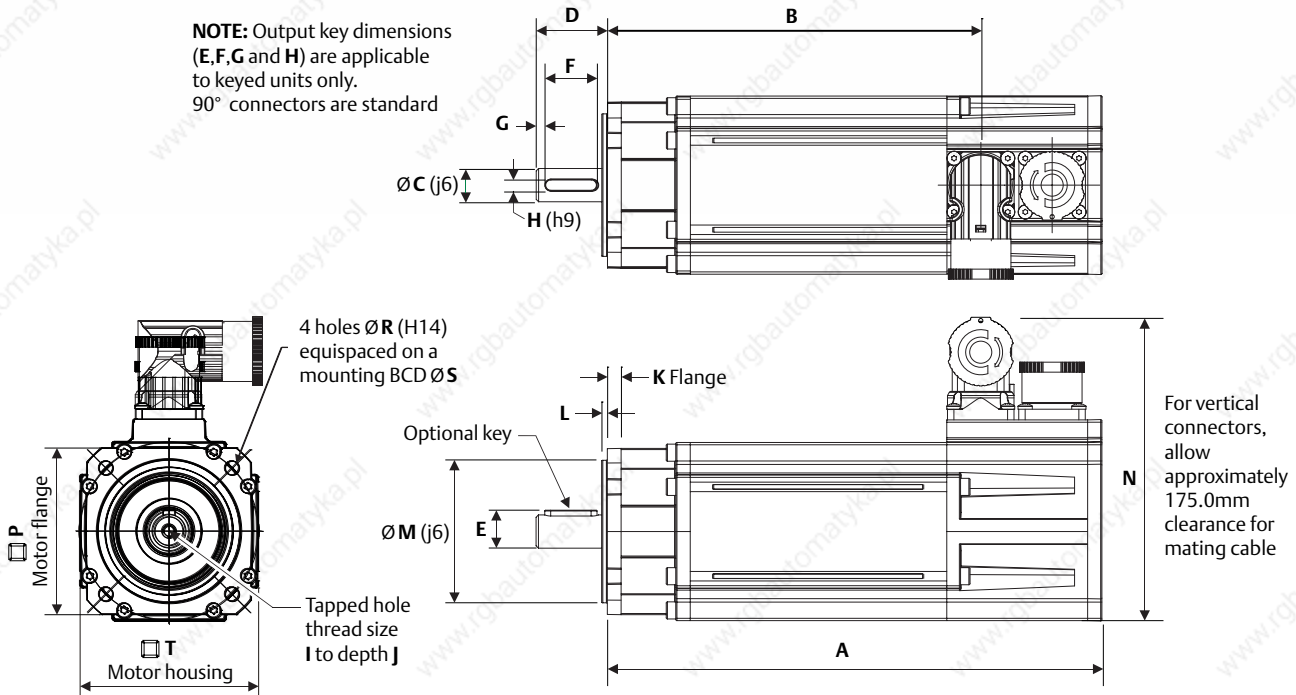

Motor Dimensions		Frame Length							
		A		B		C		D	
		(in)	(mm)	(in)	(mm)	(in)	(mm)	(in)	(mm)
Unbraked Length	A	8.20	208.2	9.38	238.2	10.56	268.2	11.74	298.2
	B	6.19	157.2	7.37	187.2	8.55	217.2	9.73	247.2
Braked Length	A	9.97	253.2	11.15	283.2	12.33	313.2	13.51	343.2
	B	7.96	202.2	9.14	232.2	10.32	262.2	11.50	292.2
Flange Thickness	K	(in)		(mm)					
Register Length	L	0.23		5.8					
Register Dia. (J6)	M	0.09		2.4					
Flange Square	P	2.36		60.0					
Mounting Hole Dia.	R	2.76		70.0					
Mounting Hole BCD	S	0.23		5.8					
Motor Housing	T	2.95		75.0					
Mounting Bolts		M5							

Optional Flange Dimensions		BCD Code					
		075		080		085	
		(in)	(mm)	(in)	(mm)	(in)	(mm)
Register Dia. (J6)	M	2.36	60.0	2.36	60.0	2.76	70.0
Flange Square	P	2.76	70.0	2.76	70.0	3.15	80.0
Mounting Hole Dia. (H14)	R	0.23	5.8	0.23	5.8	0.28	7.0
Mounting Hole BCD	S	2.6 to 3.0	66.7 to 75.0	3.0 to 3.2	75.0 to 80.0	3.4	85.0
Front End Frame Type		Extended		Extended		Flat*	

*Optional Flat Flange Motor Dimensions		Frame Length							
		A		B		C		075D	
		(in)	(mm)	(in)	(mm)	(in)	(mm)	(in)	(mm)
Unbraked Length	A <sup>1</sup>	7.58	192.6	8.76	222.6	9.94	252.6	11.13	282.6
	B <sup>2</sup>	5.57	141.6	6.76	171.6	7.94	201.6	9.12	231.6
Braked Length	A <sup>1</sup>	9.35	237.6	10.54	267.6	11.72	297.6	12.90	327.6
	B <sup>2</sup>	7.35	186.6	8.53	216.6	9.71	246.6	10.89	276.6

<sup>1</sup>±0.9mm, <sup>2</sup>±1.0mm

Shaft Dimensions		11.0mm A Std.		14.0mm B-D Std.		19.0mm Max.	
		(in)	(mm)	(in)	(mm)	(in)	(mm)
Shaft Diameter (J6)	C	0.43	11.0	0.55	14.0	0.75	19.0
Shaft Length	D <sup>1</sup>	0.91	23.0	1.18	30.0	1.57	40.0
Key Height	E <sup>2</sup>	0.49	12.5	0.63	16.0	0.85	21.5
Key Length	F <sup>3</sup>	0.55	14.0	0.87	22.0	1.26	32.0
Key-to-Shaft End	G <sup>4</sup>	0.14	3.6	0.14	3.6	0.14	3.6
Key Width (H9)	H	0.16	4.0	0.20	5.0	0.24	6.0
Tapped Hole thread Size	I	M4 x 0.4		M5 x 0.8		M6 x 1.0	
Tapped Hole Depth	J <sup>5</sup>	0.43	11.0	0.53	13.5	0.67	17.0

<sup>1</sup>±0.45mm, <sup>2</sup>To IEC 72-1, <sup>3</sup>±0.25mm, <sup>4</sup>±1.1mm, <sup>5</sup>±0.4mm

Optional Connector Height		
Connector Type	(in)	(mm)
"A"	N	4.7
"B"		5.0
"C"		5.0
"V"		4.7
		118.5

# Unimotor FM 95mm Frame Ratings

Motor Frame Size (mm)	095E2					095U2				
	230V					460V				
	Frame Length	A	B	C	D	E	A	B	C	D
Continuous Stall Torque (lb-in)	20.4	38.1	52.2	66.4	79.7	20.4	38.1	52.2	66.4	79.7
Continuous Stall Torque (Nm)	2.3	4.3	5.9	7.5	9.0	2.3	4.3	5.9	7.5	9.0
Standard (2) Peak Torque Selection Max (lb-in)	61.1	114	157	199	239	61.1	114	157	199	239
Standard (2) Peak Torque Selection Max (Nm)	6.9	12.9	17.7	22.5	27.0	6.9	12.9	17.7	22.5	27.0
High (P) Peak Torque Selection Max (lb-in)	92.0	172	235	299	358	92.0	172	235	299	358
High (P) Peak Torque Selection Max (Nm)	10.4	19.4	26.6	33.8	40.5	10.4	19.4	26.6	33.8	40.5
Standard Inertia (lb-in-sec <sup>2</sup> )	0.00156	0.00256	0.00354	0.00451	0.00549	0.00159	0.00257	0.00354	0.00451	0.00549
Standard Inertia (kgm <sup>2</sup> )	0.00018	0.00029	0.00040	0.00051	0.00062	0.00018	0.00029	0.00040	0.00051	0.00062
High Inertia (lb-in-sec <sup>2</sup> )	0.00327	0.00425	0.00522	0.00620	0.00717	0.00327	0.00425	0.00522	0.00620	0.00717
High Inertia (kgm <sup>2</sup> )	0.00037	0.00048	0.00059	0.00070	0.00081	0.00037	0.00048	0.00059	0.00070	0.00081
Winding Thermal Time Const. (s)	172	168	183	221	228	172	168	183	221	228
Motor Weight (lbs)	11.24	13.89	16.53	19.18	21.83	11.24	13.89	16.53	19.18	21.83
Motor Weight (kg)	5.1	6.3	7.5	8.7	9.9	5.1	6.3	7.5	8.7	9.9
Rated Speed 2000 rpm Kt (lb-in/A) =	12.4					21.2				
Kt (Nm/A) =	1.40					2.40				
Ke (V/krpm) =	85.50					147.0				
Rated Torque (lb-in)	19.5	35.4	48.8	61.1	72.6	19.5	35.4	48.7	61.1	72.6
Rated Torque (Nm)	2.2	4.0	5.5	6.9	8.2	2.2	4.0	5.5	6.9	8.2
Stall Current (A)	1.7	3.1	4.3	5.4	6.5	1.0	1.8	2.5	3.2	3.8
Rated Power (kW)	0.46	0.84	1.15	1.45	1.72	0.46	0.84	1.15	1.45	1.72
R (ph-ph) (Ω)	20.69	6.24	3.16	2.31	1.71	64.00	17.00	9.90	6.00	4.30
L (ph-ph) (mH)	72.40	22.50	13.73	10.79	8.70	202	54.50	36.50	25.6	18.9
Rated Speed 3000 rpm Kt (lb-in/A) =	8.23					14.2				
Kt (Nm/A) =	0.93					1.60				
Ke (V/krpm) =	57.00					98.00				
Rated Torque (lb-in)	17.7	34.5	47.8	60.2	71.7	17.7	34.5	47.8	60.2	71.7
Rated Torque (Nm)	2.0	3.9	5.4	6.8	8.1	2.0	3.9	5.4	6.8	8.1
Stall Current (A)	2.5	4.7	6.4	8.1	9.7	1.5	2.7	3.7	4.7	5.7
Rated Power (kW)	0.63	1.23	1.7	2.14	2.54	0.63	1.23	1.7	2.14	2.54
R (ph-ph) (Ω)	8.03	2.68	1.35	1.03	0.77	24.5	6.8	4	2.74	2
L (ph-ph) (mH)	22.04	8.70	6.10	4.48	3.99	57.90	24.30	15.50	13.62	8.50
Rated Speed 4000 rpm Kt (lb-in/A) =	6.37					10.62				
Kt (Nm/A) =	0.72					1.20				
Ke (V/krpm) =	44.00					73.50				
Rated Torque (lb-in)	15.9	26.6	35.4	43.4	50.4	15.9	26.6	35.4	43.4	50.4
Rated Torque (Nm)	1.8	3.0	4.0	4.9	5.7	1.8	3.0	4.0	4.9	5.7
Stall Current (A)	3.2	6.0	8.2	10.5	12.5	2.0	3.6	5.0	6.3	7.5
Rated Power (kW)	0.75	1.26	1.68	2.05	2.39	0.75	1.26	1.68	2.05	2.39
R (ph-ph) (Ω)	5.15	1.64	0.92	0.62	0.43	12.70	4.08	2.10	1.50	1.03
L (ph-ph) (mH)	13.00	7.28	3.80	2.75	2.09	31.50	13.60	8.50	6.30	4.80
Rated Speed 6000 rpm Kt (lb-in/A) =	4.16					7.08				
Kt (Nm/A) =	0.47					0.80				
Ke (V/krpm) =	28.5					49.00				
Rated Torque (lb-in)	11.5	18.5	24.7			11.5	18.5	24.7		
Rated Torque (Nm)	1.3	2.1	2.8			1.3	2.1	2.8		
Stall Current (A)	4.9	9.2	12.6			2.9	5.4	7.4		
Rated Power (kW)	0.82	1.32	1.76			0.82	1.32	1.76		
R (ph-ph) (Ω)	2.00	0.67	0.39			5.45	1.82	1.05		
L (ph-ph) (mH)	5.51	2.58	1.70			14.10	6.00	3.80		

**NOTES:**

- Δt = 212 °F (100 °C) winding 104 °F (40 °C) maximum ambient
- All data subject to ±10% tolerance
- Stall torque, rated torque and power relate to maximum continuous operation tested in a 68 °F (20 °C) ambient at 12kHz drive switching frequency
- Control Techniques has an ongoing process of development and reserves the right to change the specification without notice
- All other figures relate to a 68 °F (20 °C) motor temperature; maximum intermittent winding temperature is 284 °F (140 °C)



# Unimotor FM 95mm Frame Dimensions

**NOTE:** Output key dimensions (E,F,G and H) are applicable to keyed units only. 90° connectors are standard

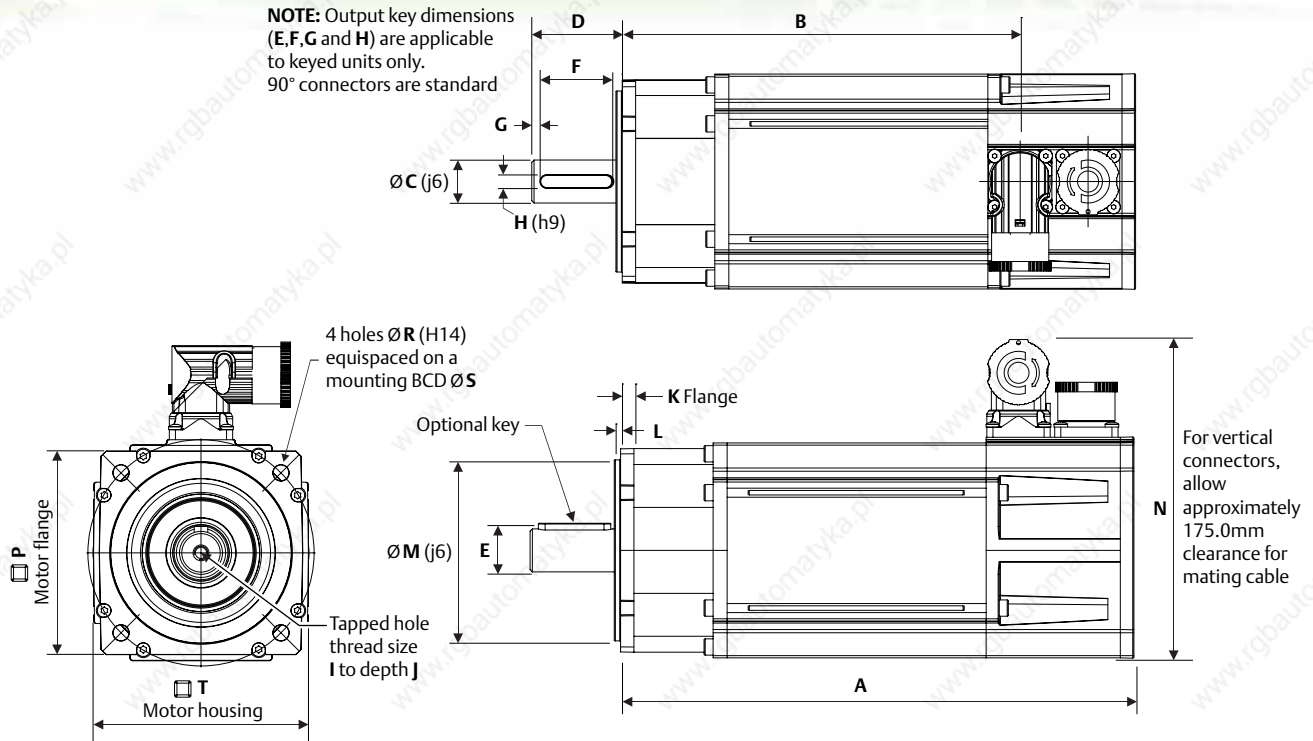

Motor Dimensions	Frame Length										
	A		B		C		D		E		
	(in)	(mm)	(in)	(mm)	(in)	(mm)	(in)	(mm)	(in)	(mm)	
Unbraked Length	A	8.93	226.9	10.11	256.9	11.30	286.9	12.48	316.9	13.66	346.9
	B	6.93	175.9	8.11	205.9	9.29	235.9	10.47	265.9	11.65	295.9
Braked Length	A	10.70	271.9	11.89	301.9	13.07	331.9	14.25	361.9	15.43	391.9
	B	8.70	220.9	9.88	250.9	11.06	280.9	12.24	310.9	13.42	340.9
		(in)				(mm)					
Flange Thickness	K	0.23				5.9					
Register Length	L	0.11				2.8					
Register Dia. (j6)	M	3.15				80.0					
Flange Square	P	3.54				90.0					
Mounting Hole Dia. (H14)	R	0.28				7.0					
Mounting Hole BCD	S	3.94				100.0					
Motor Housing	T	3.74				95.0					
Mounting Bolts		M6									

Optional Flange Dimensions	BCD Code				
	098 <sup>1</sup>		115		
	(in)	(mm)	(in)	(mm)	
Flange Thickness	K	.268	6.8	.268	6.8
Register Dia. (j6)	M	2.87	73.0	3.74	95.0
Flange Square	P	3.54	90.0	4.13	105.0
Mounting Hole Dia. (H14)	R	0.28	7.0	0.29	10.0
Mounting Hole BCD	S	3.88	98.43	4.53	115.0
Mounting Bolts		M6		M8	
Front End Frame Type		Extended		Flat*	

*Optional Flat Flange Motor Length Dimensions	Frame Length										
	A		B		C		D		E		
	(in)	(mm)	(in)	(mm)	(in)	(mm)	(in)	(mm)	(in)	(mm)	
Unbraked Length	A <sup>1</sup>	7.94	201.8	9.13	231.8	10.31	261.8	11.49	291.8	12.67	321.8
	B <sup>2</sup>	5.94	150.8	7.12	180.8	8.30	210.8	9.48	240.8	10.66	270.8
Braked Length	A <sup>1</sup>	9.72	246.8	10.90	276.8	12.08	306.8	13.26	336.8	14.44	366.8
	B <sup>2</sup>	7.71	195.8	8.89	225.8	10.07	255.8	11.25	285.8	12.43	315.8

<sup>1</sup>±0.9mm, <sup>2</sup>±1.0mm

Shaft Dimensions	14.0mm A Std.		19.0mm B-E Std.		22.0mm Max.		
	(in)	(mm)	(in)	(mm)	(in)	(mm)	
Shaft Diameter (j6)	C	0.55	14.0	0.75	19.0	0.866	22.0
Shaft Length	D <sup>1</sup>	1.18	30.0	1.57	40.0	1.97	50.0
Key Height	E <sup>2</sup>	0.63	16.0	0.85	21.5	1.0	24.5
Key Length	F <sup>3</sup>	0.87	22.0	1.26	32.0	1.63	40.0
Key-to-Shaft End	G <sup>4</sup>	0.14	3.6	0.14	3.6	0.188	4.6
Key Width (H9)	H	0.20	5.0	0.24	6.0	0.245	6.0
Tapped Hole thread Size	I	M5 x 0.8		M6 x 1.0		M8 x 1.25	
Tapped Hole Depth	J <sup>5</sup>	0.53	13.5	0.67	17.0	0.816	20.0

<sup>1</sup>±0.45mm, <sup>2</sup>To IEC 72-1, <sup>3</sup>±0.25mm, <sup>4</sup>±1.1mm, <sup>5</sup>±0.4mm

Optional Connector Height		
Connector Type	(in)	(mm)
"A"	N	5.18
"B"		5.47
"C"		5.47
"V"		5.18
		131.5

<sup>1</sup>NEMA 34 flange option; shaft diameters differ from typical NEMA 34 flange

# Unimotor FM 115mm Frame Ratings

Motor Frame Size (mm)	115E2					115U2				
	230V					460V				
	Frame Length	A	B	C	D	E	A	B	C	D
Continuous Stall Torque (lb-in)	31.0	58.4	83.2	110	135	31.0	58.4	83.2	110	135
Continuous Stall Torque (Nm)	3.5	6.6	9.4	12.4	15.3	3.5	6.6	9.4	12.4	15.3
Standard (2) Peak Torque Selection Max (lb-in)	92.9	175	250	329	406	92.9	175	250	329	406
Standard (2) Peak Torque Selection Max (Nm)	10.5	19.8	28.2	37.2	45.9	10.5	19.8	28.2	37.2	45.9
High (P) Peak Torque Selection Max (lb-in)	124	234	333	439	542	124	234	333	439	542
High (P) Peak Torque Selection Max (Nm)	14	26.4	37.6	49.6	61.2	14	26.4	37.6	49.6	61.2
Standard Inertia (lb-in-sec <sup>2</sup> )	0.00389	0.00593	0.00797	0.01009	0.01221	0.00389	0.00593	0.00797	0.01009	0.01221
Standard Inertia (kgm <sup>2</sup> )	0.00044	0.00067	0.00090	0.00114	0.00138	0.00044	0.00067	0.00090	0.00114	0.00138
High Inertia (lb-in-sec <sup>2</sup> )	0.00841	0.01044	0.01248	0.01469	0.01673	0.00841	0.01044	0.01248	0.01469	0.01673
High Inertia (kgm <sup>2</sup> )	0.00095	0.00118	0.00141	0.00166	0.00189	0.00095	0.00118	0.00141	0.00166	0.00189
Winding Thermal Time Const. (s)	175	185	198	217	241	175	185	198	217	241
Motor Weight (lbs)	17.20	21.38	25.57	29.76	33.95	17.20	21.38	25.57	29.76	33.95
Motor Weight (kg)	7.8	9.7	11.6	13.5	15.4	7.8	9.7	11.6	13.5	15.4
Rated Speed 2000 rpm Kt (lb-in/A) =	12.4					21.2				
Kt (Nm/A) =	1.4					2.40				
Ke (V/krpm) =	85.5					147.00				
Rated Torque (lb-in)	28.3	54.0	77.0	95.6	124	28.3	54.0	77.0	95.6	124
Rated Torque (Nm)	3.2	6.1	8.7	10.8	14	3.2	6.1	8.7	10.8	14
Stall Current (A)	2.5	4.8	6.8	8.9	11	1.5	2.8	4	5.2	6.4
Rated Power (kW)	0.67	1.28	1.82	2.26	2.93	0.67	1.28	1.82	2.26	2.93
R (ph-ph) (Ω)	8.33	2.82	1.51	0.99	0.72	27.8	8.55	4.55	2.96	2.17
L (ph-ph) (mH)	43.50	14.91	9.89	7.11	5.77	108	40.5	25.7	21.9	17.36
Rated Speed 3000 rpm Kt (lb-in/A) =	8.23					14.2				
Kt (Nm/A) =	0.93					1.60				
Ke (V/krpm) =	57.00					98.00				
Rated Torque (lb-in)	26.6	48.7	71.7	92.1	111.5	26.6	48.7	71.7	92.1	111
Rated Torque (Nm)	3	5.5	8.1	10.4	12.6	3	5.5	8.1	10.4	12.6
Stall Current (A)	3.8	7.1	10.2	13.4	16.5	2.2	4.2	5.9	7.8	9.6
Rated Power (kW)	0.94	1.73	2.54	3.27	3.96	0.94	1.73	2.54	3.27	3.96
R (ph-ph) (Ω)	3.7	1.3	0.73	0.47	0.37	12.6	3.86	2.02	1.4	1.08
L (ph-ph) (mH)	15.94	7.23	4.82	3.37	3.49	49.3	21.57	13.27	8.6	10.96
Rated Speed 4000 rpm Kt (lb-in/A) =	6.37					10.6				
Kt (Nm/A) =	0.72					1.20				
Ke (V/krpm) =	44.00					73.50				
Rated Torque (lb-in)	22.1	41.6	55.8	66.4		22.1	41.6	55.8	66.4	77.0
Rated Torque (Nm)	2.5	4.7	6.3	7.5		2.5	4.7	6.3	7.5	8.7
Stall Current (A)	4.9	9.2	13.1	17.3		3	5.5	7.9	10.4	12.8
Rated Power (kW)	1.05	1.97	2.64	3.14		1.05	1.97	2.64	3.14	3.64
R (ph-ph) (Ω)	2.07	0.70	0.44	0.29		6.42	2.14	1.16	0.73	0.57
L (ph-ph) (mH)	8.57	4.34	3.57	2.53		26.73	10.2	6.6	4.7	3.9
Rated Speed 6000 rpm Kt (lb-in/A) =	4.16					7.08				
Kt (Nm/A) =	0.47					0.80				
Ke (V/krpm) =	28.5					49.00				
Rated Torque (lb-in)	19.5	35.4				19.5	35.4			
Rated Torque (Nm)	2.2	4				2.2	4			
Stall Current (A)	7.5	14.1				4.4	8.3			
Rated Power (kW)	1.38	2.51				1.38	2.51			
R (ph-ph) (Ω)	0.96	0.3				3.10	0.97			
L (ph-ph) (mH)	3.43	2.09				12.3	4.81			

**NOTES:**

- Δt = 212 °F (100 °C) winding 104 °F (40 °C) maximum ambient
- All data subject to ±10% tolerance
- Stall torque, rated torque and power relate to maximum continuous operation tested in a 68 °F (20 °C) ambient at 12kHz drive switching frequency
- Control Techniques has an ongoing process of development and reserves the right to change the specification without notice
- All other figures relate to a 68 °F (20 °C) motor temperature; maximum intermittent winding temperature is 284 °F (140 °C)

# Unimotor FM 115mm Frame Dimensions

**NOTE:** Output key dimensions (E,F,G and H) are applicable to keyed units only. 90° connectors are standard

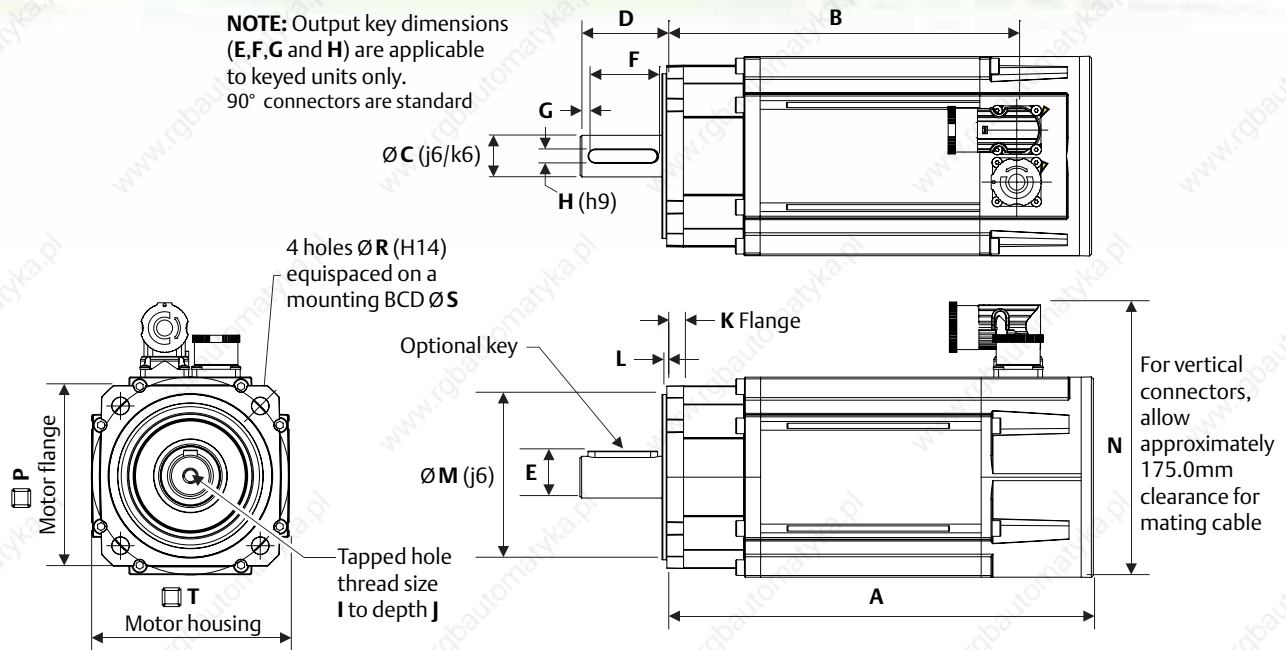

Motor Dimensions	Frame Length										
	A		B		C		D		E		
	(in)	(mm)	(in)	(mm)	(in)	(mm)	(in)	(mm)	(in)	(mm)	
Unbraked Length	A	9.65	245.2	10.83	275.2	12.02	305.2	13.20	335.2	14.38	365.2
	B	7.95	202.0	9.13	232.0	10.31	262.0	11.50	292.0	12.68	322.0
Braked Length	A	11.43	290.2	12.61	320.2	13.79	350.2	14.97	380.2	16.15	410.2
	B	9.72	247.0	10.91	277.0	12.09	307.0	13.27	337.0	14.45	367.0
Flange Thickness	K	(in)		(mm)							
Register Length	L	0.38		9.6							
Register Dia. (j6)	M	0.11		2.80							
Flange Square	P	3.74		95.0							
Mounting Hole Dia. (H14)	R	4.13		105.0							
Mounting Hole BCD	S	0.39		10.0							
Motor Housing	T	4.53		115.0							
Mounting Bolts				M8							

Optional Flange Dimensions	BCD Code	BCD Code			
		130		145	
		(in)	(mm)	(in)	(mm)
Register Dia. (j6)	M	4.33	110.0	4.33	110.0
Flange Square	P	5.12	130.0	5.12	130.0
Mounting Hole Dia. (H14)	R	0.39	10.0	0.39	10.0
Mounting Hole BCD	S	5.12	130.0	5.31 to 5.71	135.0 to 145.0
Mounting Bolts		M8			
Front End Frame Type		Flat		Flat*	

* Optional Flat Flange Motor Length Dimensions	Frame Length										
	A		B		C		D		E		
	(in)	(mm)	(in)	(mm)	(in)	(mm)	(in)	(mm)	(in)	(mm)	
Unbraked Length	A <sup>1</sup>	8.44	214.4	6.62	244.4	10.80	274.4	11.98	304.4	13.17	334.4
	B <sup>2</sup>	6.74	171.2	7.92	201.2	9.10	231.2	10.28	261.2	11.46	291.2
Braked Length	A <sup>1</sup>	10.21	259.4	11.39	289.4	12.57	319.4	13.76	349.4	14.94	379.4
	B <sup>2</sup>	8.51	216.2	9.69	246.2	10.87	276.2	12.06	306.2	13.24	336.2

<sup>1</sup>±0.9mm, <sup>2</sup>±1.0mm

Shaft Dimensions	19.0mm A-C Std.		22.0 Opt.		24.0 D-E Std.		28.0 Opt.		32.0 Max.		
	(in)	(mm)	(in)	(mm)	(in)	(mm)	(in)	(mm)	(in)	(mm)	
Shaft Dia. (j6)	C	0.75	19.0	0.87	22.0	0.94	24.0	1.10	28.0	1.26	32.0
Shaft Length	D <sup>1</sup>	1.57	40.0	1.97	50.0	1.97	50.0	2.36	60.0	3.15	80.0
Key Height	E <sup>2</sup>	0.85	21.5	0.96	24.5	1.06	27.0	1.22	31.0	1.38	35.0
Key Length	F <sup>3</sup>	1.26	32.0	1.57	40.0	1.57	40.0	1.97	50.0	2.76	70.0
Key-to-Shaft End	G <sup>4</sup>	0.14	3.6	0.18	4.6	0.18	4.6	0.18	4.6	0.18	4.6
Key Width (H9)	H	0.24	6.0	0.24	6.0	0.31	8.0	0.31	8.0	0.39	10.0
Tapped Hole Thread Size	I	M6 x 1.0		M8 x 1.25		M8 x 1.25		M10 x 1.5		M12 x 1.75	
Tapped Hole Depth	J <sup>5</sup>	0.67	17.0	0.79	20.0	0.79	20.0	0.91	23.0	1.14	29.0

Optional Connector Height		
Connector Type	(in)	(mm)
"A"	N	5.87
"B"		6.16
"C"		6.16
"V"		5.87

<sup>1</sup>±0.45mm, <sup>2</sup>To IEC 72-1, <sup>3</sup>±0.25mm, <sup>4</sup>±1.1mm, <sup>5</sup>±0.4mm



# Unimotor FM 142mm Frame Ratings

Motor Frame Size (mm)	142E2					142U2				
	230V					460V				
Voltage	230V					460V				
Frame Length	A	B	C	D	E	A	B	C	D	E
Continuous Stall Torque (lb-in)	50.5	95.6	135	175	207	50.5	95.6	135	175	207
Continuous Stall Torque (Nm)	5.7	10.8	15.3	19.8	23.4	5.7	10.8	15.3	19.8	23.4
Standard (2) Peak Torque Selection Max (lb-in)	151	287	406	526	621	151	287	406	526	621
Standard (2) Peak Torque Selection Max (Nm)	17.1	32.4	45.9	59.4	70.2	17.1	32.4	45.9	59.4	70.2
High (P) Peak Torque Selection Max (lb-in)	202	382	542	701	828	202	382	542	701	828
High (P) Peak Torque Selection Max (Nm)	22.8	43.2	61.2	79.2	93.6	22.8	43.2	61.2	79.2	93.6
Standard Inertia (lb-in-sec <sup>2</sup> )	0.00797	0.01381	0.01965	0.02549	0.03133	0.00797	0.01381	0.01965	0.02549	0.03133
Standard Inertia (kgm <sup>2</sup> )	0.00090	0.00156	0.00222	0.00288	0.00354	0.00090	0.00156	0.00222	0.00288	0.00354
High Inertia (lb-in-sec <sup>2</sup> )	0.02062	0.02646	0.03231	0.03815	0.04399	0.02062	0.02646	0.03231	0.03815	0.04399
High Inertia (kgm <sup>2</sup> )	0.00233	0.00299	0.00365	0.00431	0.00497	0.00233	0.00299	0.00365	0.00431	0.00497
Winding Thermal Time Const. (s)	213	217	275	301	365	213	217	275	301	365
Motor Weight (lbs)	22.05	29.32	35.49	41.67	47.84	22.05	29.32	35.49	41.67	47.84
Motor Weight (kg)	10	13.3	16.1	18.9	21.7	10	13.3	16.1	18.9	21.7
Rated Speed 2000 rpm Kt (lb-in/A) =	12.4					21.2				
Kt (Nm/A) =	1.4					2.40				
Ke (V/krpm) =	85.5					147.00				
Rated Torque (lb-in)	46.9	91.2	129	163	189	46.9	91.2	129	163	189
Rated Torque (Nm)	5.3	10.3	14.6	18.4	21.3	5.3	10.3	14.6	18.4	21.3
Stall Current (A)	4.1	7.8	11	14.2	16.8	2.4	4.5	6.4	8.3	9.8
Rated Power (kW)	1.11	2.16	3.06	3.85	4.46	1.11	2.16	3.06	3.85	4.46
R (ph-ph) (Ω)	4.28	1.33	0.66	0.45	0.32	12	3.6	2.1	1.35	0.98
L (ph-ph) (mH)	26.74	11.53	7.31	5.55	4.4	83	35.9	18.7	13.6	10.7
Rated Speed 3000 rpm Kt (lb-in/A) =	8.23					14.2				
Kt (Nm/A) =	0.93					1.60				
Ke (V/krpm) =	57.00					98.00				
Rated Torque (lb-in)	43.4	79.7	108	140		43.4	79.7	108	140	159
Rated Torque (Nm)	4.9	9	12.2	15.8		4.9	9	12.2	15.8	18
Stall Current (A)	6.2	11.7	16.5	21.3		3.6	6.8	9.6	12.4	14.7
Rated Power (kW)	1.54	2.83	3.83	4.96		1.54	2.83	3.83	4.96	5.65
R (ph-ph) (Ω)	1.9	0.59	0.31	0.22		5.3	1.72	0.94	0.61	0.42
L (ph-ph) (mH)	11.87	5.12	3.35	3.32		37	13.3	8.3	6.1	7.21
Rated Speed 4000 rpm Kt (lb-in/A) =	6.37					10.6				
Kt (Nm/A) =	0.72					1.20				
Ke (V/krpm) =	44.00					73.50				
Rated Torque (lb-in)	31.9	62.0				31.9	62.0	78.8	94.7	108
Rated Torque (Nm)	3.6	7				3.6	7	8.9	10.7	12.2
Stall Current (A)	8	15				4.8	9	12.8	16.5	19.5
Rated Power (kW)	1.51	2.93				1.51	2.93	3.73	4.48	5.11
R (ph-ph) (Ω)	1.2	0.36				3.0	1.0	0.53	0.35	0.25
L (ph-ph) (mH)	9.45	4.08				21.0	7.50	5.67	3.60	3.25
Rated Speed 6000 rpm Kt (lb-in/A) =	4.16					7.08				
Kt (Nm/A) =	0.47					0.080				
Ke (V/krpm) =	28.5					49.00				
Rated Torque (lb-in)	25.7					25.7	39.8			
Rated Torque (Nm)	2.9					2.9	4.5			
Stall Current (A)	12.2					7.2	13.5			
Rated Power (kW)	1.82					1.82	2.83			
R (ph-ph) (Ω)	0.49					1.33	0.46			
L (ph-ph) (mH)	3.96					9.23	3.44			

**NOTES:**

- Δt = 212 °F (100 °C) winding 104 °F (40 °C) maximum ambient
- All data subject to ±10% tolerance
- Stall torque, rated torque and power relate to maximum continuous operation tested in a 68 °F (20 °C) ambient at 12kHz drive switching frequency
- Control Techniques has an ongoing process of development and reserves the right to change the specification without notice
- All other figures relate to a 68 °F (20 °C) motor temperature; maximum intermittent winding temperature is 284 °F (140 °C)

# Unimotor FM 142mm Frame Dimensions

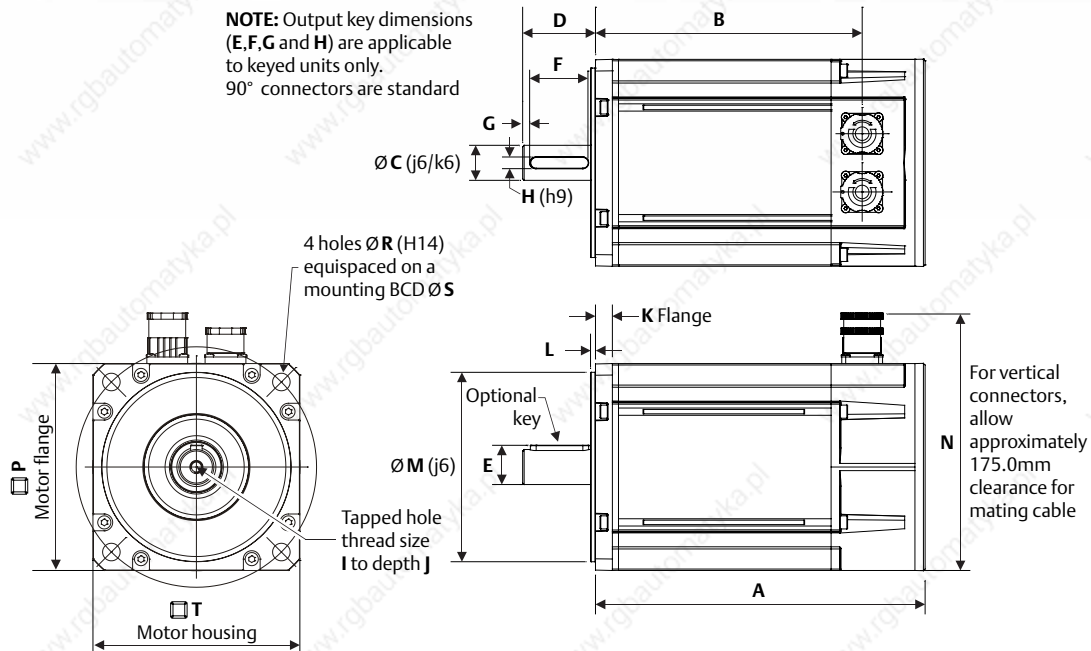

Motor Dimensions	Frame Length										
	A		B		C		D		E		
	(in)	(mm)	(in)	(mm)	(in)	(mm)	(in)	(mm)	(in)	(mm)	
Unbraked Length	A	8.92	226.2	10.09	256.2	11.27	286.2	12.45	316.2	13.63	346.2
	B	7.20	183.0	3.39	213.0	9.57	243.0	10.75	273.0	11.93	303.0
Braked Length	A	10.68	271.2	11.86	301.2	13.04	331.2	14.22	361.2	15.40	391.2
	B	8.98	228.0	10.16	258.0	11.34	288.0	12.52	318.0	13.70	348.0
Flange Thickness	K	0.46				11.6					
Register Length	L	0.13				3.4					
Register Dia. (j6)	M	5.12				130.0					
Flange Square	P	5.59				142.0					
Mounting Hole Dia. (H14)	R	0.47				12.0					
Mounting Hole BCD	S	6.50				165.0					
Motor Housing	T	5.59				142.0					
Mounting Bolts		M10									

Optional Flange Dimensions	BCD Code		
	149 <sup>1</sup>		
	(in)	(mm)	
Flange Thickness	K	0.45	11.5
Register Dia. (j6)	M	4.50	114.3
Flange Square	P	5.51	140.0
Mounting Hole Dia. (H14)	R	0.47	12.0
Mounting Hole BCD	S	5.88	149.23
Mounting Bolts	M10		
Front End Frame Type	Extended		

Opt. Flange Motor Length Dimensions	Frame Length										
	A		B		C		D		E		
	(in)	(mm)	(in)	(mm)	(in)	(mm)	(in)	(mm)	(in)	(mm)	
Unbraked Length	A <sup>1</sup>	10.76	273.4	11.94	303.4	13.13	333.4	14.31	363.4	15.49	393.4
	B <sup>2</sup>	9.06	230.2	10.24	260.2	11.43	290.2	12.61	320.2	13.79	350.2
Braked Length	A <sup>1</sup>	12.54	318.4	13.72	348.4	15.44	378.4	16.08	408.4	17.26	438.4
	B <sup>2</sup>	10.83	275.2	12.02	305.2	13.20	335.2	14.38	365.2	15.56	395.2

<sup>1</sup>±0.9mm, <sup>2</sup>±1.0mm

Shaft Dimensions	22.0 Opt.		24.0 A-E Std.		28.0 Opt		32.0 Max.		
	(in)	(mm)	(in)	(mm)	(in)	(mm)	(in)	(mm)	
Shaft Dia. (j6)	C	0.87	22.0	0.94	24.0	1.10	28.0	1.26	32.0
Shaft Length	D <sup>1</sup>	1.97	50.0	1.97	50.0	2.36	60.0	3.15	80.0
Key Height	E <sup>2</sup>	0.96	24.5	1.06	27.0	1.22	31.0	1.38	35.0
Key Length	F <sup>3</sup>	1.57	40.0	1.57	40.0	1.97	50.0	2.76	70.0
Key-to-Shaft End	G <sup>4</sup>	0.18	4.6	0.18	4.6	0.18	4.6	0.18	4.6
Key Width (H9)	H	0.24	6.0	0.31	8.0	0.31	8.0	0.39	10.0
Tapped Hole Thread Size	I	M8 x 1.25		M8 x 1.25		M10 x 1.5		M12 x 1.75	
Tapped Hole Depth	J <sup>5</sup>	0.79	20.0	0.79	20.0	0.91	23.0	1.14	29.0

<sup>1</sup>±0.45mm, <sup>2</sup>To IEC 72-1, <sup>3</sup>±0.25mm, <sup>4</sup>±1.1mm, <sup>5</sup>±0.4mm

Optional Connector Height			
Connector Type	(in)	(mm)	
"A"	N	6.93	176.0
"B"		7.22	183.5
"C"		7.22	183.5
"V"		6.93	176.0

<sup>1</sup>NEMA 56 flange option; shaft diameter 0.945in (24mm)

# Unimotor FM 230V 190mm Frame Ratings

Motor Frame Size (mm)	190E2			
Voltage	230V			
Frame Length	B	D	F	H
Continuous Stall Torque (lb-in)	193	364	520	648
Continuous Stall Torque (Nm)	21.8	41.1	58.7	73.2
Standard (2) Peak Torque Selection Max (lb-in)	579	1089	1558	1938
Standard (2) Peak Torque Selection Max (Nm)	65.4	123	176	219
Standard Inertia (lb-in-sec <sup>2</sup> )	0.04310	0.07647	0.10894	0.14319
Standard Inertia (kgm <sup>2</sup> )	0.00487	0.00864	0.01231	0.01618
High Inertia (lb-in-sec <sup>2</sup> )	0.08312	0.11648	0.14896	0.18321
High Inertia (kgm <sup>2</sup> )	0.00939	0.01316	0.01683	0.02070
Winding Thermal Time Const. (s)	240	242	319	632
Motor Weight (lbs)	55.78	74.74	93.70	113.10
Motor Weight (kg)	25.3	33.9	42.5	51.3
Rated Speed 2000 rpm Kt (lb-in/A) =	12.39			
Kt (Nm/A) =	1.4			
Ke (V/krpm) =	85.50			
Rated Torque (lb-in)	177	327	446	
Rated Torque (Nm)	20	36.9	50.4	
Stall Current (A)	15.6	29.4	42	
Rated Power (kW)	4.19	7.73	10.6	
R (ph-ph) (Ω)	0.5	0.15	0.1	
L (ph-ph) (mH)	7.77	2.5	2.73	
Rated Speed 3000 rpm Kt (lb-in/A) =	8.23			
Kt (Nm/A) =	.93			
Ke (V/krpm) =	57			
Rated Torque (lb-in)	169	292		
Rated Torque (Nm)	19.2	33		
Stall Current (A)	23.5	44.2		
Rated Power (kW)	6.03	10.4		
R (ph-ph) (Ω)	0.17	0.06		
L (ph-ph) (mH)	2.62	1.26		

**NOTES:**

- Δt = 212 °F (100 °C) winding 104 °F (40 °C) maximum ambient
- All data subject to ±10% tolerance
- Stall torque, rated torque and power relate to maximum continuous operation tested in a 68 °F (20 °C) ambient at 12kHz drive switching frequency
- Control Techniques has an ongoing process of development and reserves the right to change the specification without notice
- All other figures relate to a 68 °F (20 °C) motor temperature; maximum intermittent winding temperature is 284 °F (140 °C)



# Unimotor FM 230V 190mm Frame Dimensions

**NOTE:** Output key dimensions (E,F,G and H) are applicable to keyed units only. 90° connectors are standard

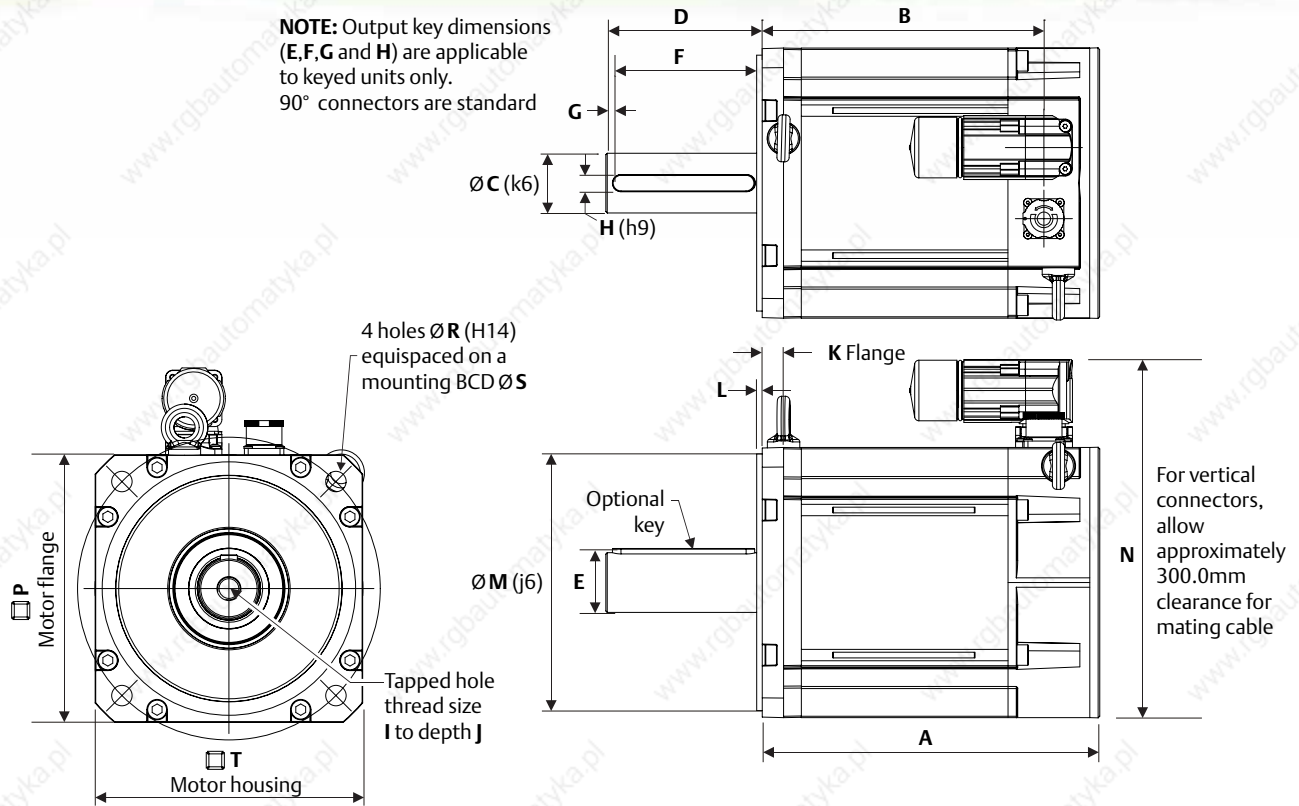

Motor Dimensions		Frame Length															
		A		B		C		D		E		F		G		H	
		(in)	(mm)	(in)	(mm)	(in)	(mm)	(in)	(mm)	(in)	(mm)	(in)	(mm)	(in)	(mm)		
Unbraked Length	A	9.35	237.4	10.41	264.3	11.47	291.3	12.53	318.2	13.59	345.2	14.65	372.1	15.71	399.1	16.77	426.0
	B	7.8	198.2	8.86	225.1	9.93	252.1	10.98	279.0	12.05	306.0	13.11	332.9	14.17	359.9	15.23	386.8
Braked Length	A	12.53	318.2	13.59	345.2	14.65	372.1	15.71	399.1	16.77	426.0	17.83	453.0	18.89	479.9	19.96	506.9
	B	10.98	279.0	12.05	306.0	13.11	332.9	14.17	359.9	15.23	386.8	16.29	413.8	17.35	440.7	18.41	467.7
Flange Thickness	K	(in)						(mm)									
Register Length	L	0.59						15.0									
Register Dia. (J6)	M	0.15						3.9									
Flange Square	P	7.09						180.0									
Mounting Hole Dia. (H14)	R	7.48						190.0									
Mounting Hole BCD	S	.057						14.5									
Motor Housing	T	8.46						215.0									
Mounting Bolts		7.48						190.0									
		M12															

Shaft Dimensions		28.0 Opt.		32.0 A-H Std.		38.0 Opt		42.0 Max.	
		(in)	(mm)	(in)	(mm)	(in)	(mm)	(in)	(mm)
Shaft Dia. (J6)	C	1.10	28.0	1.26	32.0	1.50	38.0	1.65	42.0
Shaft Length	D <sup>1</sup>	2.36	60.0	3.15	80.0	3.15	80.0	4.33	110.0
Key Height	E <sup>2</sup>	1.22	31.0	1.38	35.0	1.61	41.0	1.77	45.0
Key Length	F <sup>3</sup>	1.97	50.0	2.76	70.0	2.76	70.0	3.94	100.0
Key-to-Shaft End	G <sup>4</sup>	0.18	4.6	0.18	4.6	0.18	4.6	0.18	4.6
Key Width (H9)	H	0.31	8.0	0.39	10.0	0.39	10.0	0.47	12.0
Tapped Hole Thread Size	I	M10 x 1.5		M12 x 1.75		M12 x 1.75		M16 x 2.0	
Tapped Hole Depth	J <sup>5</sup>	0.91	23.0	1.14	29.0	1.14	29.0	1.46	37.0

Optional Connector Height		
Connector Type		
"A"	N	(in)
"B"		(mm)
"C"		(in)
"V"		(mm)

<sup>1</sup>±0.45mm, <sup>2</sup>To IEC 72-1, <sup>3</sup>±0.25mm, <sup>4</sup>±1.1mm, <sup>5</sup>±0.4mm

# Unimotor FM 460V 190mm Frame Ratings

Motor Frame Size (mm)	190U2							
Voltage	460V							
Frame Length	A	B	C	D	E	F	G	H
Continuous Stall Torque (lb-in)	85.0	193	275	364	448	520	584	648
Continuous Stall Torque (Nm)	9.6	21.8	31.1	41.1	50.6	58.7	66	73.2
Standard (2) Peak Torque Selection Max (lb-in)	255	579	826	1089	1342	1558	1752	1938
Standard (2) Peak Torque Selection Max (Nm)	28.8	65.4	93.3	123	151.6	176	198	219
Standard Inertia (lb-in-sec <sup>2</sup> )	0.02646	0.04310	0.05974	0.07647	0.09293	0.10895	0.12648	0.14320
Standard Inertia (kgm <sup>2</sup> )	0.00299	0.00487	0.00675	0.00864	0.01050	0.01231	0.01429	0.01618
High Inertia (lb-in-sec <sup>2</sup> )	0.06647	0.08311	0.09975	0.11648	0.13294	0.14896	0.16648	0.18321
High Inertia (kgm <sup>2</sup> )	0.00751	0.00939	0.01127	0.01316	0.01502	0.01683	0.01881	0.02070
Winding Thermal Time Const. (s)	217	240	241	242	281	319	476	632
Motor Weight (lbs)	46.30	55.78	65.26	74.74	84.22	93.70	103.18	113.10
Motor Weight (kg)	21	25.3	29.6	33.9	38.2	42.5	46.8	51.3
Rated Speed 2000 rpm Kt (lb-in/A) =	21.24							
Kt (Nm/A) =	2.40							
Ke (V/krpm) =	147.00							
Rated Torque (lb-in)	82.3	177	251	326	387	446	469	484
Rated Torque (Nm)	9.3	20	28.4	36.9	43.8	50.4	53	54.7
Stall Current (A)	4	9.1	13	17.2	21.1	24.5	27.5	30.5
Rated Power (kW)	1.9	4.19	5.9	7.73	9.2	10.6	11.1	11.5
R (ph-ph) (Ω)	6.15	1.54	0.83	0.5	0.39	0.3	0.3	0.17
L (ph-ph) (mH)	52.9	23.55	15	8.81	8.68	7.16	6.73	4.63
Rated Speed 3000 rpm Kt (lb-in/A) =	14.16							
Kt (Nm/A) =	1.60							
Ke (V/krpm) =	98.00							
Rated Torque (lb-in)	77.0	170	221	292	301	310	319	326
Rated Torque (Nm)	8.7	19.2	25	33	34	35	36	36.8
Stall Current (A)	6	13.7	19.4	25.7	31.6	36.7	41.3	45.8
Rated Power (kW)	2.73	6.03	7.85	10.4	10.7	11	11.3	11.6
R (ph-ph) (Ω)	2.73	0.7	0.41	0.22	0.17	0.14	0.13	0.09
L (ph-ph) (mH)	23.5	10.47	7.35	4.89	3.86	3.6	2.99	2.46
Rated Speed 4000 rpm Kt (lb-in/A) =	10.62							
Kt (Nm/A) =	1.20							
Ke (V/krpm) =	73.50							
Rated Torque (lb-in)	62.0	155	190	257				
Rated Torque (Nm)	7	17.5	21.5	29				
Stall Current (A)	8	18.2	25.9	34.2				
Rated Power (kW)	2.9	7.3	9	12.1				
R (ph-ph) (Ω)	1.35	0.38	0.21	0.11				
L (ph-ph) (mH)	13.21	6.05	3.75	2.4				

**NOTES:**

- Δt = 212 °F (100 °C) winding 104 °F (40 °C) maximum ambient
- All data subject to ±10% tolerance
- Stall torque, rated torque and power relate to maximum continuous operation tested in a 68 °F (20 °C) ambient at 12kHz drive switching frequency
- Control Techniques has an ongoing process of development and reserves the right to change the specification without notice
- All other figures relate to a 68 °F (20 °C) motor temperature; maximum intermittent winding temperature is 284 °F (140 °C)

# Unimotor FM 460V 190mm Frame Dimensions

**NOTE:** Output key dimensions (E,F,G and H) are applicable to keyed units only. 90° connectors are standard

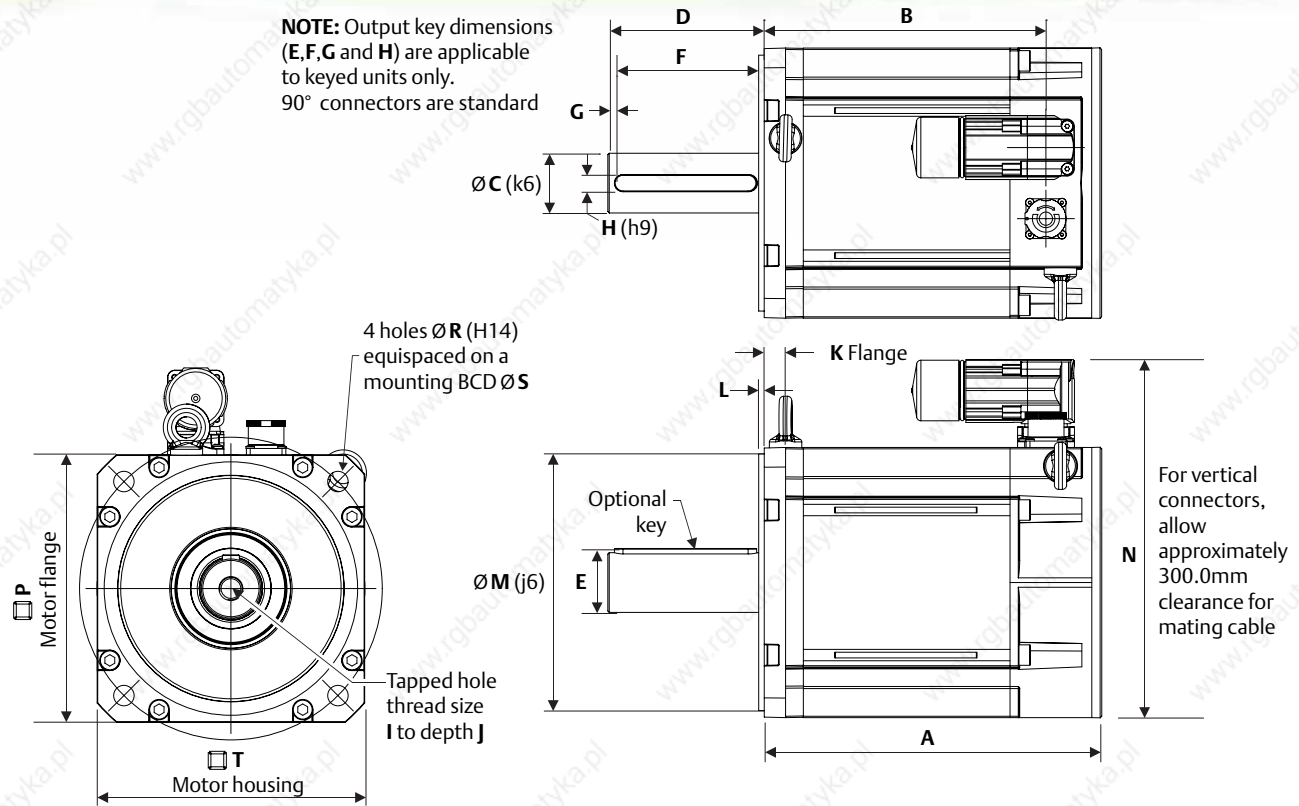

Motor Dimensions		Frame Length															
		A		B		C		D		E		F		G		H	
		(in)	(mm)	(in)	(mm)	(in)	(mm)	(in)	(mm)	(in)	(mm)	(in)	(mm)	(in)	(mm)	(in)	(mm)
Unbraked Length	A	9.35	237.4	10.41	264.3	11.47	291.3	12.53	318.2	13.59	345.2	14.65	372.1	15.71	399.1	16.77	426.0
	B	7.8	198.2	8.86	225.1	9.93	252.1	10.98	279.0	12.05	306.0	13.11	332.9	14.17	359.9	15.23	386.8
Braked Length	A	12.53	318.2	13.59	345.2	14.65	372.1	15.71	399.1	16.77	426.0	17.83	453.0	18.89	479.9	19.96	506.9
	B	10.98	279.0	12.05	306.0	13.11	332.9	14.17	359.9	15.23	386.8	16.29	413.8	17.35	440.7	18.41	467.7
Flange Thickness	K	(in)						(mm)									
Register Length	L	0.59						15.0									
Register Dia. (J6)	M	0.15						3.9									
Flange Square	P	7.09						180.0									
Mounting Hole Dia. (H14)	R	7.48						190.0									
Mounting Hole BCD	S	.057						14.5									
Motor Housing	T	8.46						215.0									
Mounting Bolts		7.48						190.0									
		M12															

Shaft Dimensions		28.0 Opt.		32.0 A-H Std.		38.0 Opt		42.0 Max.	
		(in)	(mm)	(in)	(mm)	(in)	(mm)	(in)	(mm)
Shaft Dia. (J6)	C	1.10	28.0	1.26	32.0	1.50	38.0	1.65	42.0
Shaft Length	D <sup>1</sup>	2.36	60.0	3.15	80.0	3.15	80.0	4.33	110.0
Key Height	E <sup>2</sup>	1.22	31.0	1.38	35.0	1.61	41.0	1.77	45.0
Key Length	F <sup>3</sup>	1.97	50.0	2.76	70.0	2.76	70.0	3.94	100.0
Key-to-Shaft End	G <sup>4</sup>	0.18	4.6	0.18	4.6	0.18	4.6	0.18	4.6
Key Width (H9)	H	0.31	8.0	0.39	10.0	0.39	10.0	0.47	12.0
Tapped Hole Thread Size	I	M10 x 1.5		M12 x 1.75		M12 x 1.75		M16 x 2.0	
Tapped Hole Depth	J <sup>5</sup>	0.91	23.0	1.14	29.0	1.14	29.0	1.46	37.0

Optional Connector Height			
Connector Type	(in)	(mm)	
"A"	N	9.65	245.0
"B"		9.94	252.5
"C"		9.94	252.5
"V"		9.13	232.0

<sup>1</sup>±0.45mm, <sup>2</sup>To IEC 72-1, <sup>3</sup>±0.25mm, <sup>4</sup>±1.1mm, <sup>5</sup>±0.4mm



# Unimotor FM Fan Blown Motors 460V

## Overview

Based on Unimotor FM mechanics with modified electromagnetic construction, the fan blown version has been designed to give greater performance across the torque range. For example, the 190 fan blown variant increases the stall torque from 447.8 to 601.9lb-in (50.6 to 68Nm) when compared to the standard Unimotor FM motor. This extra torque allows for increased application performance with higher rms values achievable.

The motors available have been selected to give the best torque increases across the available frame sizes. To allow for the higher currents required, the 142 fan blown range is only available with the size 1.5 (53A rated) power connector.



## Ordering information

Use the information below to create an order code for a Unimotor FM (top row is an example). (Std = Standard selection, Opt = Optional selection)

095	U	4	D	60	0	V	A	MA	A	100	220
Frame size	Motor voltage	Peak torque selection	Stator length	Winding speed (rpm)	Brake	Connection type*	Output shaft	Feedback device	Inertia	PCD	Shaft diameter
	075-190 frame	075-190 frame	075 frame	075 frame	075-190 frame	075-190 frame	075-190 frame	075-142 frame	075-190 frame	075 frame	
075	U = 400V	4 = Peak torque	D	60 = 6000	0 = Not fitted (Std)	A = Power and Signal 90° fixed	A = Keyed	AE = Resolver	A = Standard	075 Std	19.0 D Std
095			095 frame	095 frame	1 = Parking brake fitted 24Vdc	B = Power and Signal 90° rotatable	B = Plain shaft	CA = Incremental Encoder 4096 ppr	B = High	095 frame	
115			D	60 = 6000				MA = Incremental Encoder 2048 ppr		100 Std	22.0 D Std
142			115 frame	115 frame	5 = High energy dissipation parking brake	C = Power 90° rotatable and Signal vertical		KA = Incremental Encoder 1024 ppr		115 frame	
190			D	40 = 4000 rpm				EB = Optical Absolute Multi-turn EQN 1325		115 Std	24.0 D Std
			E	142 frame		V = Power and Signal vertical		EC = Inductive Absolute Multi-turn EQI 1331		28.0 E Std	
			142 frame	30 = 3000				FB = Optical Absolute Single turn ECN 1313		142 frame	
			C	190 frame				FC = Inductive Absolute Single turn ECI 1319		165 Std	28.0 C/E Std
			E	C & E: 30 = 3000				RA = Optical SinCos Multi-turn SRM 50		190 frame	
			190 frame	F: 20 = 2000				SA = Optical SinCos Single turn SRS 50		215 Std	32.0 C Std
			C					190 frame only			38.0 E/F Std
			E					AE = Resolver			
			F					CA = Incremental Encoder (Std) 4096 ppr			
								MA = Incremental Encoder 2048 ppr			
								EB = Optical Absolute Multi-turn EQN 1325			
								FB = Optical Absolute Single turn ECN 1313			
								RA = Optical SinCos Multi-turn SRM 50			
								SA = Optical SinCos Single turn SRS 50			

\*For 142 and 190 frame motors, power plug is size 1.5 and required power cable "motor end" is order code "B"

# Unimotor FM Fan Blown 75mm Frame Ratings & Dimensions

Motor Frame Size (mm)	075E2
Voltage (Vrms)	380 to 480
Frame Length	D
Continuous Stall Torque (lb-in)	46.02
Continuous Stall Torque (Nm)	5.20
Peak Torque Selection Max (lb-in)	103.55
Peak Torque Selection Max (Nm)	11.70
Standard Inertia (lb-in-sec <sup>2</sup> )	17.70
Standard Inertia (kgm <sup>2</sup> )	.0002
High Inertia (lb-in-sec <sup>2</sup> )	.00212
High Inertia (kgm <sup>2</sup> )	.00024
Winding Thermal Time Const. (s)	100
Rated Speed 6000 rpm Kt (lb-in/A) =	49.00
Kt (Nm/A) =	0.8
Ke (V/krpm) =	4.00
Rated Torque (lb-in)	35.40
Rated Torque (Nm)	4.00
Stall Current (A)	6.50
Rated Power (hp)	1.87
Rated Power (kW)	2.51
R (ph-ph) (Ω)	1.90
L (ph-ph) (mH)	4.80



Fan Rating 230Vac @ 0.05A

Motor Dimensions		075	
		D	
		(in)	(mm)
Unbraked Length	A	15.65	397.4
	B	9.73	247.2
Braked Length	A	17.42	442.4
	B	11.50	292.2
		(in)	(mm)
Flange Thickness	K	0.23	5.8
Register Length	L	0.09	2.4
Register Dia. (J6)	M	2.36	60.0
Fan Box Overall Height	W	4.79	121.6
Flange Square	P	2.76	70.0
Mounting Hole Dia. (H14)	R	0.23	5.8
Mounting Hole BCD	S	2.95	75.0
Fan Box Housing	X	3.61	91.6
Mounting Bolts		M5	

Shaft Dimensions		19.0 D Std	
		(in)	(mm)
Shaft Dia. (J6)	C	0.75	19.0
Shaft Length	D <sup>1</sup>	1.57	40.0
Key Height	E <sup>2</sup>	0.85	21.5
Key Length	F <sup>3</sup>	1.26	32.0
Key-to-Shaft End	G <sup>4</sup>	0.14	3.6
Key Width (H9)	H	0.24	6.0
Tapped Hole Thread Size	I	M6 x 1.0	
Tapped Hole Depth	J <sup>5</sup>	0.67	17.0

<sup>1</sup>±0.45mm, <sup>2</sup>To IEC 72-1, <sup>3</sup>±0.25mm, <sup>4</sup>±1.1mm, <sup>5</sup>±0.4mm

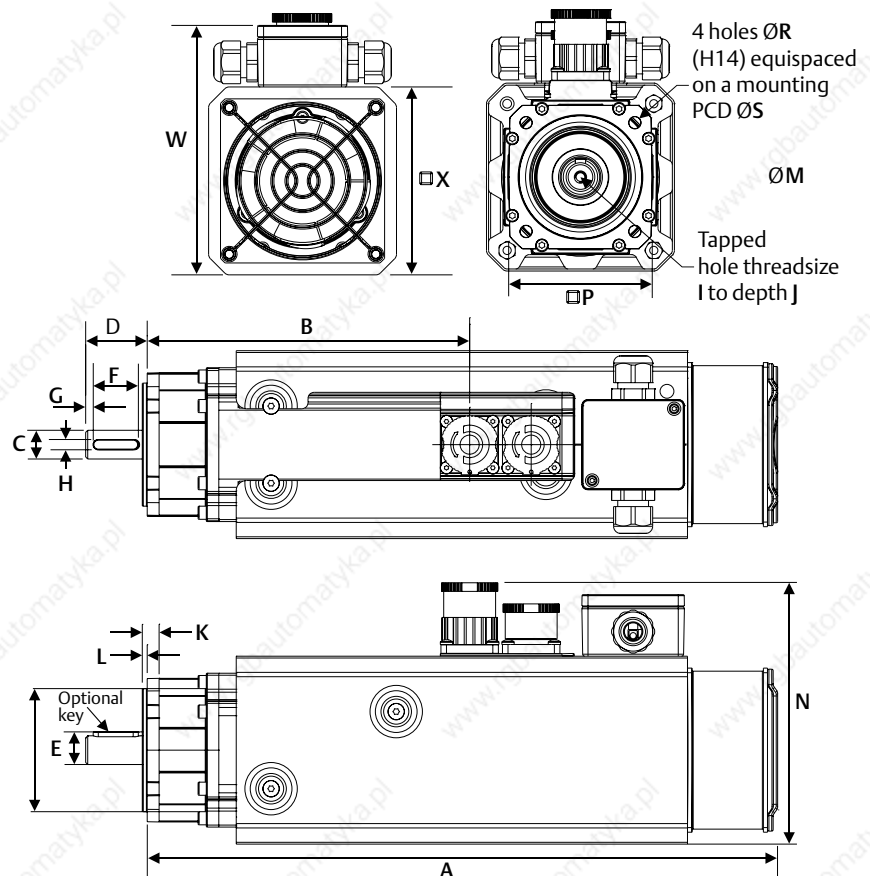

Overall Height		
Connector Type	(in)	(mm)
"A"	4.98	126.5
"B"	5.28	134.0
"C"	5.28	134.0
"V"	4.98	126.5

NOTES:

- Stall torque, rated torque and power relate to maximum continuous operation tested in a 68°F (20°C) ambient at 12kHz drive switching frequency. All other figures relate to a 68°F (20°C) motor temperature. Maximum intermittent winding temperature is 284°F (140°C)
- Δt= 212°F (100°C) winding 104°F (40°C) maximum ambient
- All data subject to +/-10% tolerance

# Unimotor FM Fan Blown 95mm Frame Ratings & Dimensions

<b>Motor Frame Size (mm)</b>	<b>095U4</b>
<b>Voltage (Vrms)</b>	<b>380 to 480</b>
<b>Frame Length</b>	<b>D</b>
Continuous Stall Torque (lb-in)	79.7
Continuous Stall Torque (Nm)	9.0
Peak Torque Selection Max (lb-in)	199.1
Peak Torque Selection Max (Nm)	22.5
Standard Inertia (lb-in-sec <sup>2</sup> )	45.14
Standard Inertia (kgm <sup>2</sup> )	5.10
High Inertia (lb-in-sec <sup>2</sup> )	61.95
High Inertia (kgm <sup>2</sup> )	7.00
Winding Thermal Time Const. (s)	221
Rated Speed 6000 rpm Kt (lb-in/A) =	7.08
Kt (Nm/A) =	0.80
Ke (V/krpm) =	49.00
Rated Torque (lb-in)	51.33
Rated Torque (Nm)	5.80
Stall Current (A)	11.30
Rated Power (hp)	6.19
Rated Power (kW)	8.30
R (ph-ph) (Ω)	0.62
L (ph-ph) (mH)	2.70



Fan Rating 230Vac @ 0.05A

Motor Dimensions		095	
		D	
		(in)	(mm)
Unbraked Length	A	15.22	386.6
	B	10.47	265.9
Braked Length	A	16.99	431.6
	B	12.24	310.9
		(in)	(mm)
Flange Thickness	K	0.23	5.9
Register Length	L	0.11	2.8
Register Dia. (J6)	M	3.15	80.0
Fan Box Overall Height	W	5.57	141.6
Flange Square	P	3.54	90.0
Mounting Hole Dia. (H14)	R	0.28	7.0
Mounting Hole BCD	S	3.94	100.0
Fan Box Housing	X	4.39	111.6
Mounting Bolts	M6		

Shaft Dimensions		122.0 D	Std
		(in)	(mm)
Shaft Dia. (J6)	C	0.87	22.0
Shaft Length	D <sup>1</sup>	1.97	50.0
Key Height	E <sup>2</sup>	0.96	24.5
Key Length	F <sup>3</sup>	1.57	40.0
Key-to-Shaft End	G <sup>4</sup>	0.18	4.6
Key Width (H9)	H	0.24	6.0
Tapped Hole Thread Size	I	M8 x 1.25	
Tapped Hole Depth	J <sup>5</sup>	0.79	20.0

<sup>1</sup>±0.45mm, <sup>2</sup>To IEC 72-1, <sup>3</sup>±0.25mm, <sup>4</sup>±1.1mm, <sup>5</sup>±0.4mm

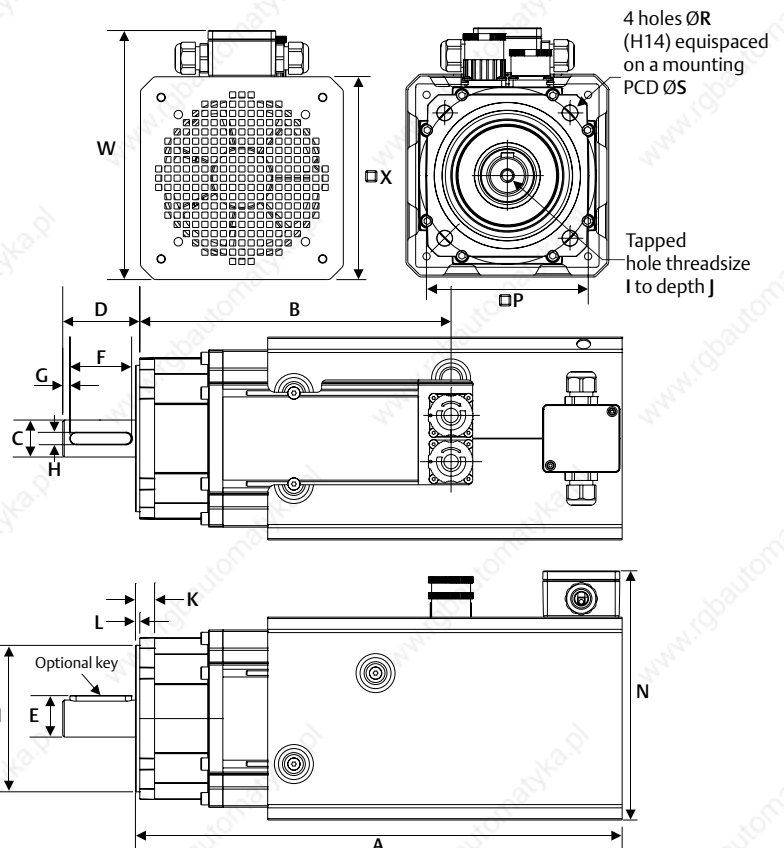

Overall Height		
Connector Type	(in)	(mm)
"A"	5.49	139.5
"B"	5.79	147.0
"C"	5.79	147.0
"V"	5.49	139.5

**NOTES:**

- Stall torque, rated torque and power relate to maximum continuous operation tested in a 68°F (20°C) ambient at 12kHz drive switching frequency. All other figures relate to a 68°F (20°C) motor temperature. Maximum intermittent winding temperature is 284°F (140°C)
- Δt= 212°F (100°C) winding 104°F (40°C) maximum ambient
- All data subject to +/-10% tolerance



# Unimotor FM Fan Blown 115mm Frame Ratings & Dimensions

Motor Frame Size (mm)	115U4	
Voltage (Vrms)	380 to 480	
Frame Length	D	E
Continuous Stall Torque (lb-in)	134.5	177.8
Continuous Stall Torque (Nm)	15.2	20.1
Peak Torque Selection Max (lb-in)	329.2	406.2
Peak Torque Selection Max (Nm)	37.2	45.9
Standard Inertia (lb-in-sec <sup>2</sup> )	100.8	122.1
Standard Inertia (kgm <sup>2</sup> )	11.4	13.8
High Inertia (lb-in-sec <sup>2</sup> )	146.9	167.3
High Inertia (kgm <sup>2</sup> )	16.6	18.9
Winding Thermal Time Const. (s)	217	241
Rated Speed 6000 rpm Kt (lb-in/A) =	10.62	
Kt (Nm/A) =	1.20	
Ke (V/krpm) =	73.50	
Rated Torque (lb-in)	106.2	142.5
Rated Torque (Nm)	12.0	16.1
Stall Current (A)	12.7	16.8
Rated Power (hp)	3.75	5.03
Rated Power (kW)	5.03	6.74
R (ph-ph) (Ω)	0.73	0.57
L (ph-ph) (mH)	4.70	3.90



Fan Rating 230Vac @ 0.08A

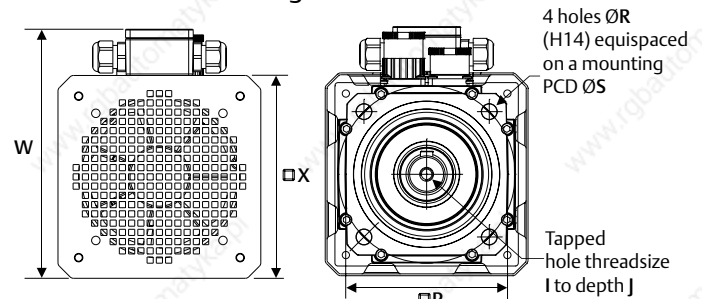

Motor Dimensions	115				
		D		E	
		(in)	(mm)	(in)	(mm)
Unbraked Length	A	15.87	403.00	17.05	433.00
	B	11.50	292.00	12.68	322.00
Braked Length	A	17.64	448.00	18.82	478.00
	B	13.27	337.00	14.45	367.00
		(in)	(mm)		
Flange Thickness	K	0.38	9.6		
Register Length	L	0.11	2.8		
Register Dia. (J6)	M	3.74	95.0		
Fan Box Overall Height	W	6.36	161.6		
Flange Square	P	4.13	105.0		
Mounting Hole Dia. (H14)	R	0.39	10.0		
Mounting Hole BCD	S	4.53	115.0		
Fan Box Housing	X	5.18	131.6		
Mounting Bolts		M8			

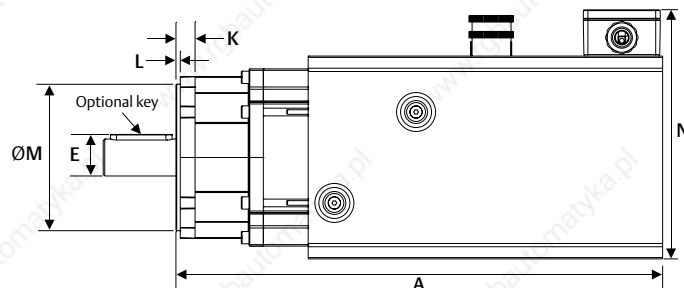
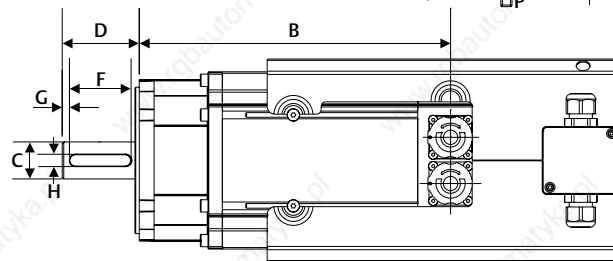

Shaft Dimensions	24.0 D Std		28.0 E Std		
	(in)	(mm)	(in)	(mm)	
Shaft Dia. (J6)	C	0.94	24.0	1.10	28.0
Shaft Length	D <sup>1</sup>	1.97	50.0	2.36	60.0
Key Height	E <sup>2</sup>	1.06	27.0	1.22	31.0
Key Length	F <sup>3</sup>	1.57	40.0	1.97	50.0
Key-to-Shaft End	G <sup>4</sup>	0.18	4.6	0.18	4.6
Key Width (H9)	H	0.31	8.0	0.31	8.0
Tapped Hole Thread Size	I	M8 x 1.25		M10 x 1.5	
Tapped Hole Depth	J <sup>5</sup>	0.79	20.0	0.91	23.0

<sup>1</sup>±0.45mm, <sup>2</sup>To IEC 72-1, <sup>3</sup>±0.25mm, <sup>4</sup>±1.1mm, <sup>5</sup>±0.4mm

Overall Height		
Connector Type	(in)	(mm)
"A"	6.18	157.0
"B"	6.48	164.5
"C"	6.48	164.5
"V"	6.18	157.0

NOTES:

- Stall torque, rated torque and power relate to maximum continuous operation tested in a 68°F (20°C) ambient at 12kHz drive switching frequency. All other figures relate to a 68°F (20°C) motor temperature. Maximum intermittent winding temperature is 284°F (140°C)
- Δt= 212°F (100°C) winding 104°F (40°C) maximum ambient
- All data subject to +/-10% tolerance

# Unimotor FM Fan Blown 142mm Frame Ratings & Dimensions

Motor Frame Size (mm)	142U4	
Voltage (Vrms)	380 to 480	
Frame Length	C	E
Continuous Stall Torque (lb-in)	167.3	261.1
Continuous Stall Torque (Nm)	18.90	29.5
Peak Torque Selection Max (lb-in)	406.22	621.3
Peak Torque Selection Max (Nm)	45.90	70.2
Standard Inertia (lb-in-sec <sup>2</sup> )	196.47	313.3
Standard Inertia (kgm <sup>2</sup> )	22.20	35.4
High Inertia (lb-in-sec <sup>2</sup> )	323.03	439.9
High Inertia (kgm <sup>2</sup> )	36.50	49.7
Winding Thermal Time Const. (s)	275	365
Rated Speed 6000 rpm Kt (lb-in/A) =	14.16	
Kt (Nm/A) =	1.60	
Ke (V/krpm) =	98.00	
Rated Torque (lb-in)	142.5	221.3
Rated Torque (Nm)	16.1	25.0
Stall Current (A)	11.8	18.4
Rated Power (hp)	3.77	5.85
Rated Power (kW)	5.06	7.85
R (ph-ph) (Ω)	0.94	0.44
L (ph-ph) (mH)	8.30	5.77



Fan Rating 230Vac @ 0.08A

Motor Dimensions	142				
		C		E	
		(in)	(mm)	(in)	(mm)
Unbraked Length	A	14.45	367.0	16.81	427.0
	B	9.83	249.7	12.19	309.7
Braked Length	A	16.22	412.0	18.58	472.0
	B	11.60	294.7	13.96	354.7
Flange Thickness	K	0.46	11.6		
Register Length	L	0.13	3.4		
Register Dia. (J6)	M	5.12	130.0		
Fan Box Overall Height	W	7.41	188.1		
Flange Square	P	5.59	142.0		
Mounting Hole Dia. (H14)	R	0.47	12.0		
Mounting Hole BCD	S	6.50	165.0		
Fan Box Housing	X	6.24	158.6		
Mounting Bolts	M10				

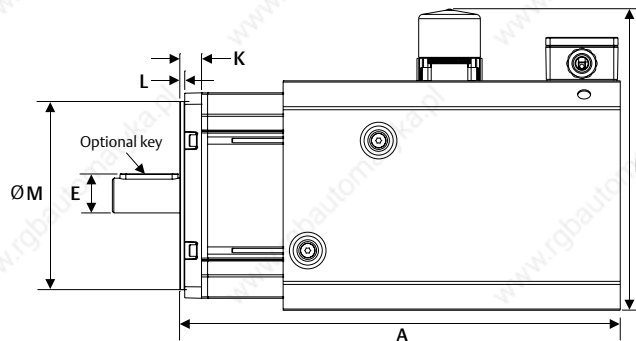
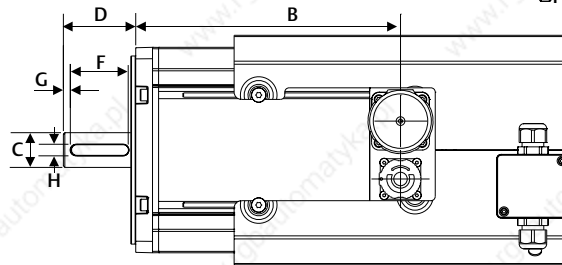
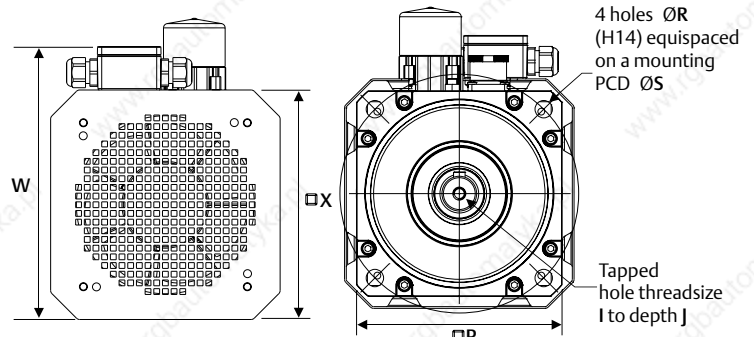

Shaft Dimensions	28.0 C/E Std	
	(in)	(mm)
Shaft Dia. (J6)	C	1.10 / 28.0
Shaft Length	D <sup>1</sup>	2.36 / 60.0
Key Height	E <sup>2</sup>	1.22 / 31.0
Key Length	F <sup>3</sup>	1.97 / 50.0
Key-to-Shaft End	G <sup>4</sup>	0.18 / 4.6
Key Width (H9)	H	0.31 / 8.0
Tapped Hole Thread Size	I	M10 x 1.5
Tapped Hole Depth	J <sup>5</sup>	0.91 / 23.0

<sup>1</sup>±0.45mm, <sup>2</sup>To IEC 72-1, <sup>3</sup>±0.25mm, <sup>4</sup>±1.1mm, <sup>5</sup>±0.4mm

Overall Height							
Connector Type	(in)	(mm)	Connector Type	(in)	(mm)		
"A"	N	7.24	184.0	"C"	N	7.54	191.5
"B"	N	7.54	191.5	"V"	N	7.24	184.0

- NOTES:
- Stall torque, rated torque and power relate to maximum continuous operation tested in a 68°F (20°C) ambient at 12kHz drive switching frequency. All other figures relate to a 68°F (20°C) motor temperature. Maximum intermittent winding temperature is 284°F (140°C).
  - Δt= 212°F (100°C) winding 104°F (40°C) maximum ambient
  - All data subject to +/-10% tolerance

# Unimotor FM Fan Blown 190mm Frame Ratings & Dimensions

Motor Frame Size (mm)	190U4		
Voltage (Vrms)	380 to 480		
Frame Length	C	E	F
Continuous Stall Torque (lb-in)	362.9	601.8	699.2
Continuous Stall Torque (Nm)	41.0	68.0	79.0
Std. (2) Peak Torque Selection Max (lb-in)	825.7	1341.7	1559.4
Std. (2) Peak Torque Selection Max (Nm)	93.3	151.6	176.2
Standard Inertia (lb-in-sec <sup>2</sup> )	597.4	929.3	1089.4
Standard Inertia (kgm <sup>2</sup> )	67.5	105.0	123.1
High Inertia (lb-in-sec <sup>2</sup> )	997.40	1329.27	1489.46
High Inertia (kgm <sup>2</sup> )	112.7	150.2	168.30
Winding Thermal Time Const. (s)	241	281	319
Rated Speed 2000 rpm Kt (lb-in/A) =			21.24
Kt (Nm/A) =			2.40
Ke (V/krpm) =			147.00
Rated Torque (lb-in)			588.53
Rated Torque (Nm)			66.5
Stall Current (A)			32.9
Rated Current (A)			27.7
Rated Power (hp)			10.37
Rated Power (kW)			13.9
R (ph-ph) (Ω)			0.30
L (ph-ph) (mH)			7.16
Rated Speed 3000 rpm Kt (lb-in/A) =		14.16	
Kt (Nm/A) =		1.60	
Ke (V/krpm) =		98.00	
Rated Torque (lb-in)	314.2	486.8	
Rated Torque (Nm)	35.5	55.0	
Stall Current (A)	25.6	42.5	
Rated Power (hp)	8.31	12.90	
Rated Power (kW)	11.15	17.30	
R (ph-ph) (Ω)	0.41	0.17	
L (ph-ph) (mH)	7.35	3.86	

**NOTES:**

- Stall torque, rated torque and power relate to maximum continuous operation tested in a 68°F (20°C) ambient at 12kHz drive switching frequency. All other figures relate to a 68°F (20°C) motor temperature. Maximum intermittent winding temperature is 284°F (140°C)
- Δt= 212°F (100°C) winding 104°F (40°C) maximum ambient
- All data subject to +/-10% tolerance

Shaft Dimensions		32.0 C Std		38.0 E/F Std	
		(in)	(mm)	(in)	(mm)
Shaft Dia. (J6)	C	1.26	32.0	1.49	38.0
Shaft Length	D <sup>1</sup>	3.15	80.0	3.15	80.0
Key Height	E <sup>2</sup>	1.38	35.0	1.61	41.0
Key Length	F <sup>3</sup>	2.76	70.0	2.76	70.0
Key-to-Shaft End	G <sup>4</sup>	0.18	4.6	0.18	4.60
Key Width (H9)	H	0.39	10.0	0.39	10.0
Tapped Hole Thread Size	I	M12 x 1.75			
Tapped Hole Depth	J <sup>5</sup>	1.14	29.0	1.14	29.0

<sup>1</sup>±0.45mm, <sup>2</sup>To IEC 72-1, <sup>3</sup>±0.25mm, <sup>4</sup>±1.1mm, <sup>5</sup>±0.4mm

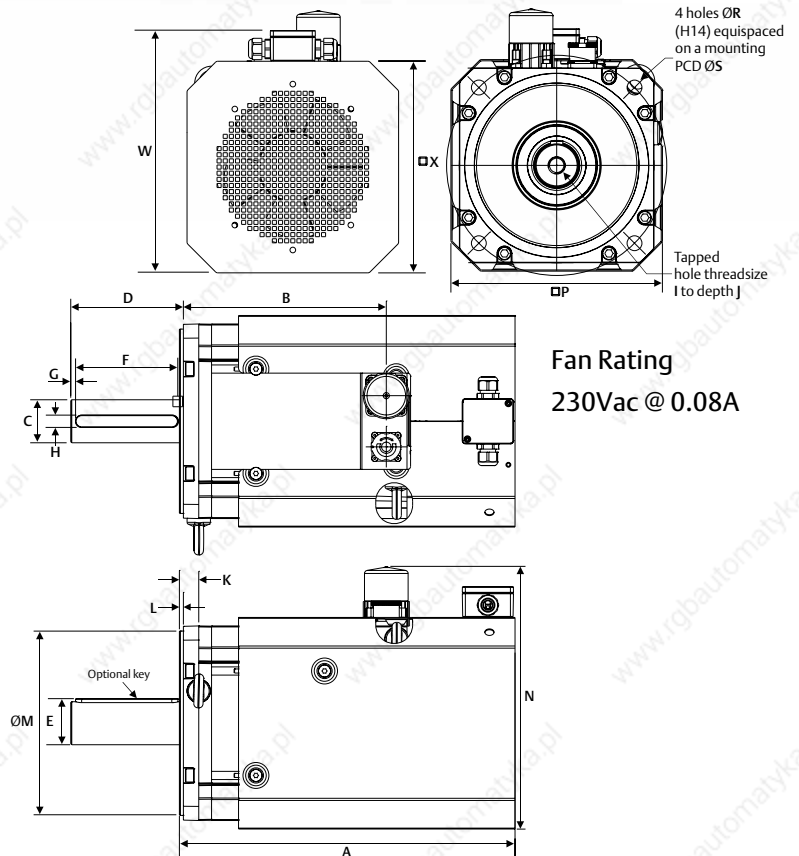

**Fan Rating**  
230Vac @ 0.08A

Motor Dimensions		190					
		C		E		F	
		(in)	(mm)	(in)	(mm)	(in)	(mm)
Unbraked Length	A	14.87	377.8	17.00	431.7	18.06	458.6
	B	9.93	252.1	12.05	306.0	13.11	332.9
Braked Length	A	18.06	458.6	20.18	512.5	21.24	539.5
	B	13.11	332.9	15.23	386.8	16.29	413.8
		(in)		(mm)			
Flange Thickness	K	0.59		15.0			
Register Length	L	0.15		3.9			
Register Dia. (J6)	M	7.09		180.0			
Fan Box Overall Height	W	9.31		236.6			
Flange Square	P	7.48		190.0			
Mounting Hole Dia. (H14)	R	0.57		14.5			
Mounting Hole BCD	S	8.46		215.0			
Fan Box Housing	X	8.13		206.6			
Mounting Bolts		M12					

Overall Height			
Connector Type			
"A"	N	9.96	253.0
"B"		10.26	260.5
"C"		10.26	260.5
"V"		9.45	240.0



# Unimotor FM Motor Selection Considerations

## Feedback

Feedback Device Order Code	Feedback Type	Encoder Supply Voltage <sup>1</sup>	SinCos Cycles or Incremental Pulses per Revolution	Resolution Available to Position Loop <sup>2&amp;3</sup>	Feedback Accuracy <sup>1</sup>
<b>055 motors</b>					
AR	Resolver	7V	1	Medium	Low
		Excitation 5kHz		16384 (14 bit)	+/- 600"
KR	Incremental Encoder	5V	1024	Medium	Medium
MR			2048	8192 (13 bit)	+/- 150"
CR			4096	16384 (14 bit)	
EM (Multi-turn) FM (Single-turn)	Inductive Absolute Encoder EnDat 2.1	5V	16	High	Medium
TL (Multi-turn) UL (Single-turn)	SinCos Optical Encoder Hiperface	7 - 12V	128	2.62x10 <sup>5</sup> (18 bits)	+/- 480"
				High	High
				4096	
				1.31x10 <sup>5</sup> (17 bit)	+/- 52"
<b>075-190 motors</b>					
AE	Resolver	6 Vrms Excitation 6kHz	1	Medium	Medium
				16384 (14 bit)	+/- 720"
CA	Incremental Encoder	5V	4096	Medium	High
				16384 (14 bit)	+/- 60"
EC (Multi-turn) FC (Single-turn)	Inductive Absolute Encoder EnDat 2.1	7 - 10V	32	Medium	Medium
				Absolute position	+/- 280"
				524288	
				(19 bits)	
RA (Multi-turn) SA (Single-turn)	SinCos Optical Encoder Hiperface	7 - 12V	1024	Very high	High
				1.04x10 <sup>6</sup>	For SinCos Integral non-linearity +/- 45" For SinCos Differential non-linearity +/- 7" (Total accuracy +/- 52")
				(20 bits)	
EB (Multi-turn) FB (Single-turn)	Optical Absolute Encoder EnDat 2.2	3.6 - 14V	2048	Very High	Very High
				2.08x10 <sup>6</sup>	+/- 20" (Differential non linearity +/- 1% signal period)
				(21 bits)	

- Notes:**
- 1) The output from the resolver is an analog output; the resolution is determined by the analog to digital converter used; the value shown is when the resolver is used in conjunction with the SM-Resolver
  - 2) The sin and cosine outputs from the SinCos optical encoders are analog outputs; with Unidrive SP and Digitax ST the resolutions quoted above are when the encoder type is set to either SC Endat or SC Hiperface depending on the encoder
  - 3) The information is supplied by the feedback device manufacturer and relates to it as a standalone device; the values may change when mounted into the motor and connected to a drive

## Unimotor FM Peak Torque Information

Unimotor FM has two levels of peak torque available within the range – standard peak torque (code 2) and the high peak torque range (code P). On some frame sizes, full peak torque cannot be achieved at the full 100% rms current level. As shown below, the 055 and 075 motors are not affected by the reduced levels and remain constant up to 100% rms current, whereas the 095 to 190 motors all show a drop at

some point along the % rms current line. The graph below shows the standard peak factor for each frame size.

As shown below, the 075 increases to 5 times, the 095 increases to 4.5 times, the 115 increases to 4 times across the % rms current line and the 142 shows an increase to 4 times up to 57% rms current dropping to 2.5 times at 100%.

### Standard (2) Peak Torque

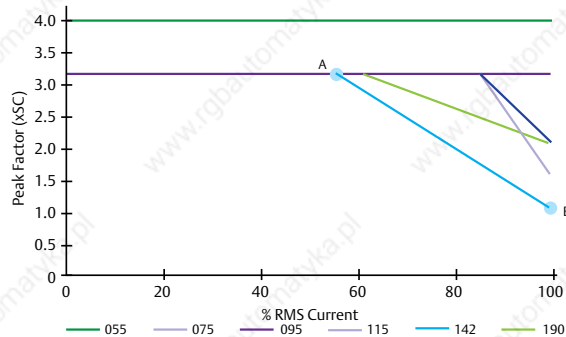

### High (P) Peak Torque

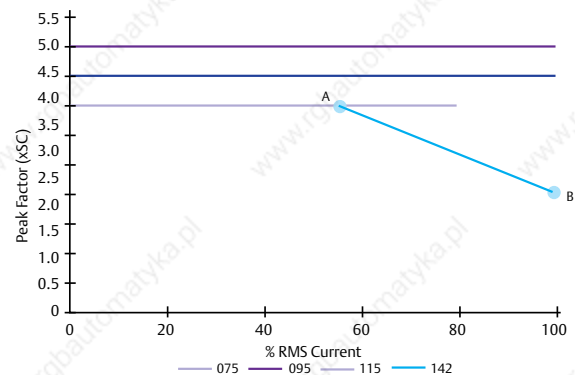



# Unimotor FM Motor Selection Considerations

## Motor Selection

### Motor Derating

Any adverse operating conditions require that the motor performance be derated. These conditions include ambient temperature above 104 °F (40 °C), motor mounting position, drive switching frequency or a drive oversized for the motor.

### Ambient Temperatures

For ambient temperatures above 104 °F (40 °C), the torque must be derated using the following formula as a guideline (only applies to motors up to 3000rpm and assumes copper losses dominate).

$$\text{New derated torque} = \frac{\text{Specified torque} \times \sqrt{1 - ([\text{ambient temperature}^* - 40] / 100)}}{\text{Measured in } ^\circ\text{C}}$$

\*Measured in °C

For example, with an ambient temperature of 169 °F (76 °C), the new derated torque will be 0.8 x specified torque.

### Drive Switching Frequency

Most drive current ratings are reduced at higher switching frequencies. See individual drive manuals for details.

See the table below for motor derating factors (these figures are for guidance only).

### Motor Derating Factors

Switching Frequency	Motor Type/Frame								
	055 A-C	075 A-D	095 A-E	115 A-C	115 D-E	142 A-C	142 D-E	190 A-B	190 C-H
3kHz	0.92	0.93	0.88	0.89	0.84	0.87	0.81	0.98	N/A
4kHz	0.93	0.94	0.91	0.91	0.87	0.91	0.86	0.99	0.55
5/6kHz	0.95	0.95	0.93	0.93	0.90	0.94	0.89	0.99	0.77
8kHz	0.96	0.98	0.97	0.97	0.95	0.97	0.96	1	0.90
10/12/16kHz	1	1	1	1	1	1	1	1	1

### Mounting Arrangements

In general, motor torque should be derated if the motor mounting surface is heated from an external source such as a gearbox, the motor is connected to a poor thermal conductor, or the motor is mounted in a confined space with restricted air flow.

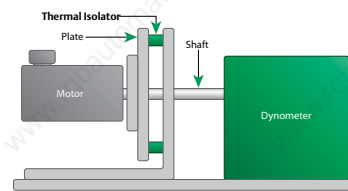

Motor Type/Frame	Aluminum Heatsink Plate	
	(in)	(mm)
055	4.3 x 4.3 x 1.06	110 x 110 x 27
075-095	9.8 x 9.8 x 0.6	250 x 250 x 15
115-142	13.8 x 13.8 x 0.8	350 x 350 x 20
190	19.7 x 19.7 x 0.8	500 x 500 x 20

### IP Ratings

#### Motor

IP65S - No ingress of dust; no contact with or approach to live or moving parts inside the enclosure. Water projected by a nozzle against enclosure from any direction shall have no harmful effects (excluding the front shaft seal); S = device standing still during water test

#### Fan motor and circuit board

IP54 - The fan motor and circuit board are coated to protect them against water splash and humidity.

#### Complete Unimotor fan blown motor assembly

IP20 - Protected against solid objects > 12mm (e.g. fingers)

## 230V and 460V FM Motor Holding Brake Specifications

Motor Frame Size (mm)	Power Supply (Vdc)	Current (A)	Static Torque		Mechanical Engagement Time (ms)	Added Inertia		Added Weight	
			(lb-in)	(Nm)		(lb-in-sec <sup>2</sup> )	(kgcm <sup>2</sup> )	(lb)	(kg)
55	24	0.27	15.9	1.8	24	0.00003	0.03	0.9	0.4
75	24	0.27	17.7	2	24	0.00006	0.07	1.1	0.5
95	24	0.67	97.3	11	20	0.00035	0.39	1.3	0.6
115	24	0.67	97.3	11	10	0.00039	0.44	2.6	1.2
142	24	0.81	159	18	30	0.00048	0.54	3.7	1.7
190(A-D)	24	1.05	336	38	15	0.00272	3.07	4.4	2
190(E-H)	24	1.05	531	60	15	0.00438	4.95	4.4	2

# Cables for Servo Motors

## Servo Motor Cables

Cables are a vital part of a servo motor installation. Using Control Techniques' comprehensive range of high quality cables and connector options, installers can avoid the time and risks involved in manufacturing custom assemblies.

The matched power and feedback cables provide rapid worry-free installation. Control Techniques' servo motor-to-drive cables meet EMC standards to ensure a system free from unwanted noise and interference.

Each power cable has drive terminations that make it convenient to connect to the specific drive used.

Cables are available for braked and unbraked motors and in standard or flexible duty formats.

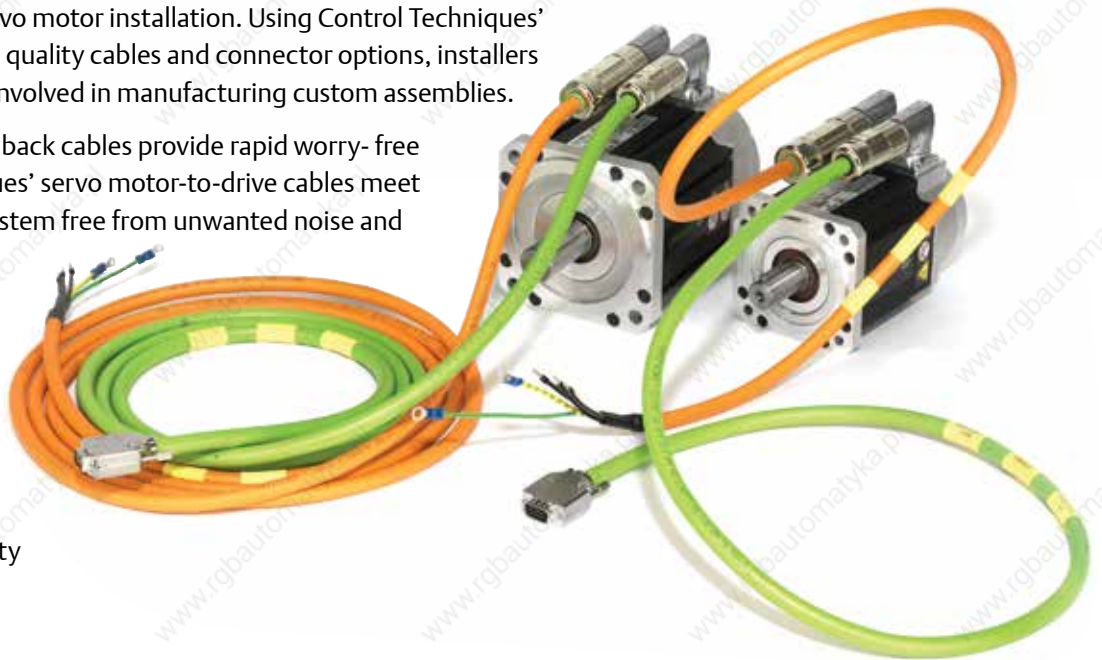

## Cable Selection Guide

Cable Type	Servo Motors			Servo Drives			
	Unimotor HD/fm	NT	XV	Digitax ST	Unidrive SP	Epsilon EP	MDS
★PS	✓	✓		✓	✓	✓	✓
★PB	✓	✓		✓	✓	✓	✓
CM		✓				✓	✓
XT			✓	✓	✓	✓	
XCM			✓ (130 frame)	✓	✓	✓	
<b>Feedback</b>							
★SI	✓	✓		✓	✓	✓	✓
★SR	✓			✓	✓		
★SS	✓	✓		✓	✓		
UF		✓		✓	✓	✓	
CF		✓					✓
XU			✓	✓	✓	✓	
XCF			✓	✓	✓	✓	

NOTE:  
★Flex duty cables

# Cable Selection – Unimotor HD, Unimotor FM, NT (-EOxS)

Power Cables					
PS	B	A	H	A	015
Cable Type	Jacket	Phase and Ground Conductor Size*	Connection Details – Drive End	Connection Details – Motor End	Cable Length
PS = Power (standard)	B = PUR	G = 1.5mm <sup>2</sup> – up to 16A	C = Extension power connector, 6-way	A= Size 1 power connector	Min=001 (meters)
PB – Power (with brake)		A = 2.5mm <sup>2</sup> – up to 22A	F = Digitax ST and Unidrive SP (Size 0)	055 to 115 Unimotor HD, NT (-ExxS)	Max=100 (meters)
		B = 4.0mm <sup>2</sup> – up to 30A	Unidrive SP (Size 1-2)	055 to 142 Unimotor FM	<b>Standard Cable Lengths</b>
		C = 6.0mm <sup>2</sup> – up to 39A	G = Unidrive SP (Size 3)	075 to 115 Unimotor Fan Blown	
		D = 10.0mm <sup>2</sup> – up to 53A	J = Unidrive SP (Size 4)	B= Size 1.5 power connector	003 (meters)
		E = 16.0mm <sup>2</sup> – up to 70A	K = Epsilon EP, EN, MDS	142 Unimotor HD:	005 (meters)
			X = Cut end	142ED - frames C, D, E; 2000, 3000rpm	010 (meters)
				142UD - frames D,E; 3000rpm	015 (meters)
				190 Unimotor HD	020 (meters)
				190 Unimotor FM	025 (meters)
				142 to 190 Unimotor Fan Blown	030 (meters)
				X=Cut end	

**NOTES:**

\* Phase and ground connector note: Select CONDUCTOR SIZE according to motor's STALL CURRENT

- Ratings are for individual cables (not lashed together) in free air temperature up to 104 °F (40 °C) – make allowances as appropriate

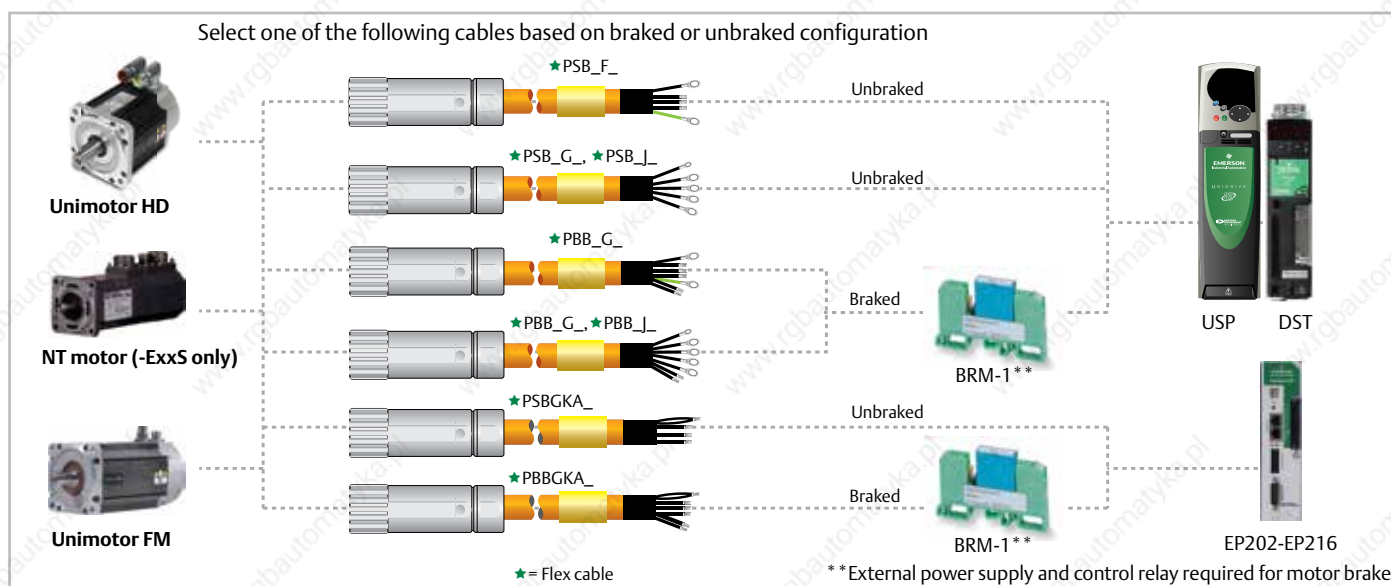

## FM, HD, NT (-EOxS) Motor Power Cables

Part Number	Standard Lengths (m)	Description – Power Cable* Unbraked
★ PSB_F_	005, 010, 015, 020, 025, 030	Digitax ST, Unidrive SP (size 0, 1 and 2) motor power with ferrules (ring lugs on ground), flex rated
★ PSB_G_	005, 010, 015, 020, 025, 030	Unidrive SP (size 3) motor power with ring lugs, flex rated
★ PSB_J_	005, 010, 015, 020, 025, 030	Unidrive SP (size 4) motor power with ring lugs, flex rated
★ PSBGKA	005, 010, 015, 020, 025, 030	Epsilon EP202 to EP216 motor power with ferrules, flex rated
Part Number	Standard Lengths (m)	Description – Power Cable* Braked
★ PBB_F_	005, 010, 015, 020, 025, 030	Digitax ST, Unidrive SP (size 0, 1 and 2) motor power with ferrules (ring lugs on ground), flex rated
★ PBB_G_	005, 010, 015, 020, 025, 030	Unidrive SP (size 3) motor power with brake leads with ring lugs, flex rated
★ PBB_J_	005, 010, 015, 020, 025, 030	Unidrive SP (size 4) motor power with brake leads with ring lugs, flex rated
★ PBBGKA	005, 010, 015, 020, 025, 030	Epsilon EP202 to EP216 motor power with brake leads with ferrules, flex rated
BRM-1	–	Brake module, DIN rail mount

**NOTE:**

\* Custom lengths available in 2m increments

# Cable Selection – Unimotor HD, Unimotor FM, NT (-ExxS)

## Power Extension Cable Options: Motor to SP/DST/EP

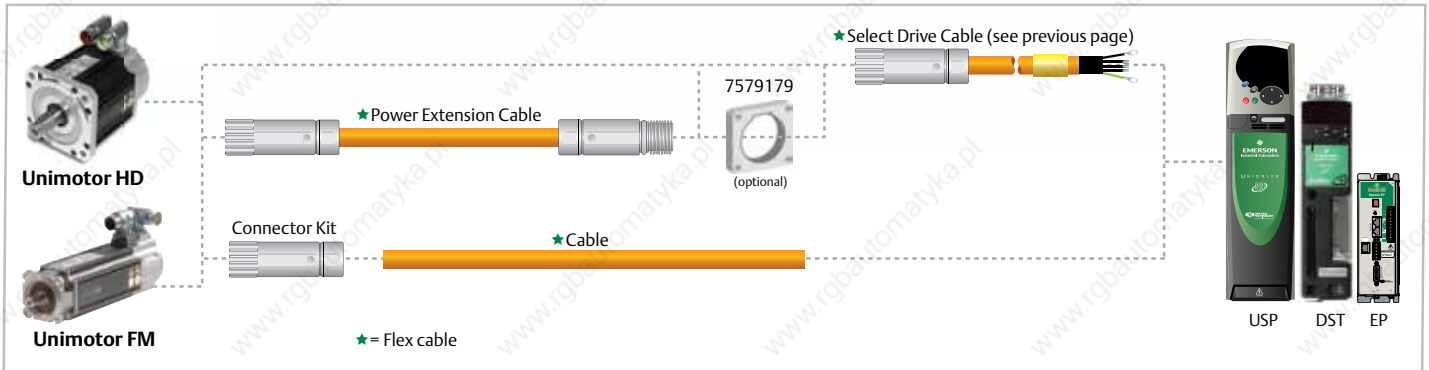

Part Number	Standard Lengths (m)	Description – Connector Kits (includes brake pins)
IM/0039/KI	—	Power connector kit, female 055, 115, 142 frame (30A); B connector type
IM/0044/KI	—	Power connector kit, female 055, 115, 142 frame (39A); J connector type
IM/0053/KI	—	Power connector kit, female 190 frame up to (53A)
IM/0054/KI	—	Power connector kit, female 190 frame up to (70A)
7579179	—	Bulkhead flange kit for power connector size 1
Part Number	Standard Lengths (m)	Description – Power Extension Cable*
★PSB_CA	005, 010, 015, 020, 025, 030	Motor power extension, flex rated, 055 to 115 frames and NT (-EOxS); 142 frame B connector type
★PBB_CA	005, 010, 015, 020, 025, 030	Motor power extension w/brake leads, flex rated, 055 to 115 frames and NT (-EOxS); 142 frame J connector type
★PSB_CB	005, 010, 015, 020, 025, 030	Motor power, extension flex rated, 190 frame
★PBB_CB	005, 010, 015, 020, 025, 030	Motor power extension w/brake leads, flex rated, 190 frame
Part Number	Standard Lengths (m)	Description – Cable

Undressed cable is available using cut-end order code option (example PSBAXX)

**NOTES:**

- \* Custom lengths available in 2m increments
- Fill in blank with appropriate conductor size

Conductor Size	Drive
G = 1.5mm <sup>2</sup> (16A)	All Digitax ST, All Epsilon EP, MD-404, MD-407, MD410
A = 2.5mm <sup>2</sup> (22A)	Unidrive SP up to 22A, MD-420
B = 4.0mm <sup>2</sup> (30A)	Unidrive SP up to 30A
C = 6.0mm <sup>2</sup> (39A)	Unidrive SP up to 39A, MD-434
D = 10.0mm <sup>2</sup> (53A)	Unidrive SP up to 53A
E = 16.0mm <sup>2</sup> (70A)	Unidrive SP up to 70A



## Cable Selection – Unimotor HD, Unimotor FM, NT (-EOxS)

Feedback Cables					
SI	B	A	A	A	015
Cable Type	Jacket	Special Options	Connection Details – Drive End	Connection Details – Motor End	Cable Length
SI = Incremental encoder hyperboloid pins	B = PUR	A = Standard cable	A = Digitax ST/Unidrive SP/Epsilon EP incremental encoder 15-pin connector	A = Incremental encoder connector	Min = 001 (meters)
SR = Resolver		E = Twisted screened SS cable option only	B = Resolver/SinCos encoder ferrules	B = Resolver connector	Max = 100 (meters)
SS = SinCos encoder		F = MDS incremental encoder 26-pin connector	C = SinCos connector (Hiperface) (SICK Stegmann)		
		I = Extension connector male pins	E = 17-way extension connector		
		H = Digitax ST/Unidrive SP SinCos, 15-pin connector	N = SinCos connector (EnDat) (Heidenhain)		
		X = Cut end	X = Cut end		

### Feedback Cable Options – Motor to SP/DST/EP – Incremental Encoders

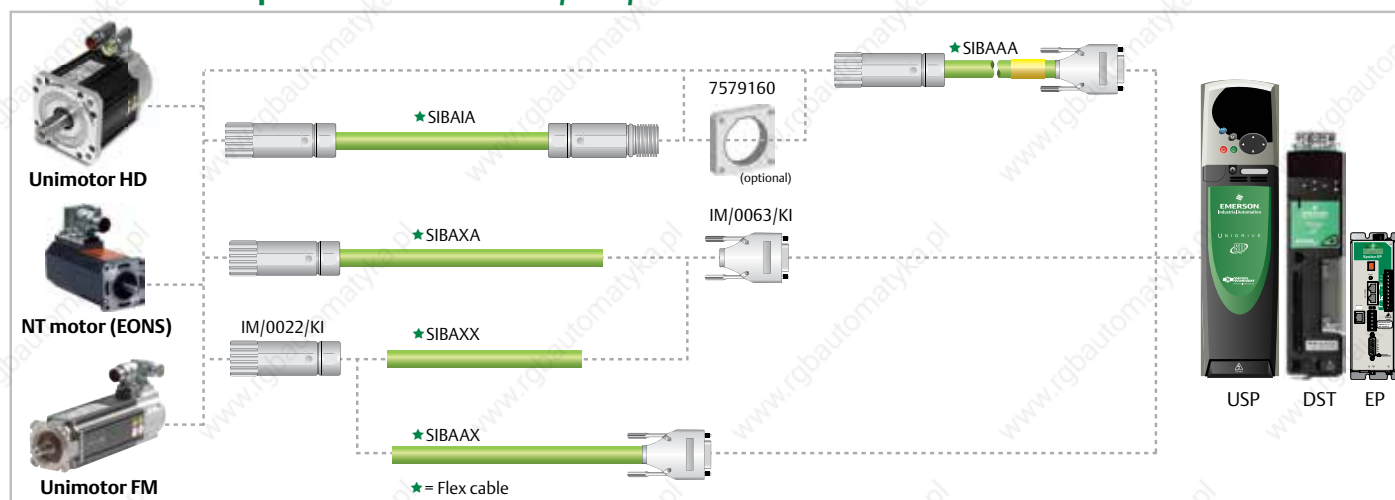

Part Number	Standard Lengths (m)	Description – Feedback Cables* and Connectors
★SIBAAA	005, 010, 015, 020, 025, 030	Incremental encoder feedback, connectors both ends, drive and motor connection, flex duty
★SIBAIA	005, 010, 015, 020, 025, 030	Extension cable, Incremental encoder feedback, connectors both ends, connects to SIBAAA cable and motor connector, flex duty
★SIBAXX	005, 010, 015, 020, 025, 030	Incremental encoder feedback, connector on drive end, flex duty
★SIBAXA	005, 010, 015, 020, 025, 030	Incremental encoder feedback, connector on motor end, flex duty
★SIBAXX	2-meter increments	Incremental encoder feedback cable, no connectors, flex duty
IM/0022/KI	—	Feedback connector kit, incremental encoders, 055 frame
IM/0063/KI	—	Feedback connector kit, includes pins, drive end, 15-pin
7579160	—	Optional feedback connector flange kit for bulkhead, size 1.0 connector
Part Number	Standard Lengths (m)	Description – Encoder Breakout Board
STI-ENC	—	Epsilon EP drive encoder breakout PCB, push-in terminals
SM-ECT	—	Unidrive SP, Digitax ST drives encoder breakout PCB, screw terminals

NOTE:

\*Custom lengths available in 2m increments

# Cable Selection – Unimotor HD, Unimotor FM, NT (-EOxS)

## Feedback Cable Options – Motor to SP/DST – Absolute and Resolver Feedback

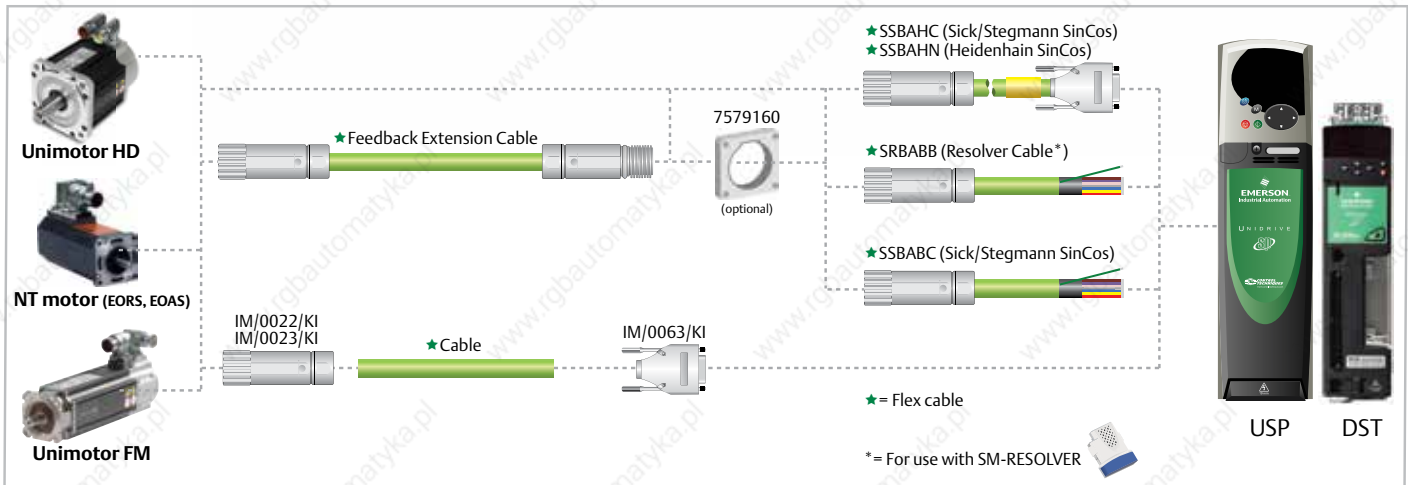

Part Number	Standard Lengths (m)	Description – Feedback Cables*
★SSBABC	005, 010, 015, 020, 025, 030	Sick/Stegmann (Hiperface) SinCos encoder feedback cable, 12-pin on encoder end, flying leads on drive end, flex duty
★SSBAHC	005, 010, 015, 020, 025, 030	Sick/Stegmann (Hiperface) SinCos encoder feedback cable, 12-pin on encoder end, 15-pin d-sub on drive end, flex duty
★SSBAHN	005, 010, 015, 020, 025, 030 (30m max.)	Heidenhain (EnDat) SinCos encoder feedback cable, 12-pin on encoder end, 15-pin d-sub on drive end, flex duty
★SSBEHN	005, 010, 015, 020, 025, 030 (100m max.)	Heidenhain (EnDat) SinCos encoder feedback cable, noise immune, 12-pin on encoder end, 15-pin d-sub on drive end, flex duty
Part Number	Standard Lengths (m)	Description – Feedback Cable Connectors
IM/0022/KI	–	Feedback connector kit, Heidenhain SinCos encoders
IM/0023/KI	–	Feedback connector kit, Sick/Stegmann SinCos encoders or resolver
IM/0063/KI	–	Feedback connector kit, includes pins, drive end, 15-pin
7579160	–	Optional feedback connector flange kit for bulkhead; size 1.0 connector
Part Number	Standard Lengths (m)	Description – Feedback Extension Cables*
★SSBAIC	005, 010, 015	Feedback extension cable for feedback options TL, UL, RA, SA (SICK SinCos Hiperface), flex duty
★SSBAIN	005, 010, 015	Feedback extension cable for feedback options EM, FM, EC, EB, FB (-EOAS[NT] Heidenhain SinCos EnDat) flex duty
★SRBAIB	005, 010, 015, 020, 025, 030	Feedback extension cable for feedback options AR, AE, -EORS(NT) (resolver) flex duty
Part Number	Standard Lengths (m)	Description – Cable
★SRBAXX	2-meter increments	Cable for resolver feedback, no connectors, flex duty
★SSBAXX	2-meter increments	Cable for SinCos feedback, no connectors, flex duty, must specify SICK or Heidenhain cable types with order
Part Number	Standard Lengths (m)	Description – Encoder Breakout Board
STI-ENC	–	Epsilon EP drive encoder breakout PCB, push-in terminals
SM-ECT	–	Unidrive SP, Digitax ST drives encoder breakout PCB, screw terminals

NOTE:  
\*Custom lengths available in 2m increments

# Cable Selection – Unimotor HD, Unimotor FM, NT Motor (-EOxS)

## Power – PUR Basic Cable Diameters

Cable Code	Phase and Conductor Size (Current Rating Cenlec En60204.1) (mm <sup>2</sup> )	Overall Cable Diameter			
		No Brake		Braked	
		(in)	(mm)	(in)	(mm)
PxBG	G - 1.5 (16A)	0.334	8.5	0.425	10.8
PxBA	A - 2.5 (22A)	0.394	10.0	0.496	12.6
PxBB	B - 4.0 (30A)	0.461	11.7	0.555	14.1
PxBC	C - 6.0 (39A)	0.685	17.4	0.685	17.4

**NOTES:**

- Minimum bend radius = 10x dia. long chain, 7.5x dia. short chain
- Bending life 10,000,000 cycles
- Maximum acceleration = 65.6ft/s<sup>2</sup> (20m/s<sup>2</sup>)
- Temperature rating = 14 to 176 °F (-10 to 80 °C)

## Feedback – PUR Basic Cable Diameters

Cable Code	Overall Cable Diameter	
	(in)	(mm)
SIBA	0.429	10.9
SRBA/SSBA	0.378	9.6

**NOTES:**

- Minimum bend radius = 10x dia. long chain, 7.5x dia. short chain
- Bending life 10,000,000 cycles
- Maximum acceleration: SRBA/SSBA = 65.6ft/s<sup>2</sup> (20m/s<sup>2</sup>)  
SIBA/SIBL = 32.8ft/s<sup>2</sup> (10m/s<sup>2</sup>)
- Temperature rating = 14 to 176 °F (-10 to 80°C)

## Motor Connector Details

Pin	Power Plug		Feedback Plug			
	Size 1.0 [with Brake]	Size 1.5 [with Brake]	Incremental Encoder (CR, CA, MA, MR, KR, KA)	EnDat Heidenhain SinCos, Absolute Encoders (EM, FM, EC, FC, EB, FB)	Resolver (AR, AE)	Hyperface SICK Stegmann SinCos, Absolute Encoders (RA, SA, TL, UL)
1	Phase U (R)	Phase U (R)	Thermistor	Thermistor	Excitation high	REF cos
2	Phase V (S)	Phase V (S)	Thermistor	Thermistor	Excitation low	+Data
3	Ground	Ground (⊕)		Screen (optical encoder only)	Cos high	-Data
4	Phase W (T)	Phase W (T)	U		Cos low	+Cos
5	[Brake]	[Brake (+)]	U/		Sin high	+Sin
6	[Brake]	[Brake (-)]	V		Sin low	REF sin
7			V/		Thermistor	Thermistor
8			W	+ Clock	Thermistor	Thermistor
9			W/	- Clock		Screen
10			A	+ Cos		0 Volts
11			Z	+ Data		
12			Z/	- Data		+ Volts
13			A/	- Cos		
14			B	+ Sin		
15			B/	- Sin		
16			+ Volts	+ V		
17			0 Volts	0 Volts		
Shell	Shield	Shield	Shield	Shield		Shield

## Maximum Cable Lengths

Cable Types	Maximum Cable Length (Meters)		
	Resolver	Sick Stegmann	Heidenhain
SIBA incremental		CA/CR 50m*	
SRBA Resolver	AR/AE 100m		
SSBA SinCos		RA/SA 100m	EC/FC 20m EB/FB 30m
SSBE SinCos, twisted pair			EC/FC 20m EB/FB 100m

**NOTES:**

- \*328ft. (100m) only if +5V tolerance can be maintained @ ±10%

### Power Plugs

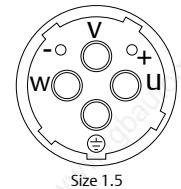

### Feedback Plugs

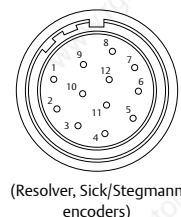
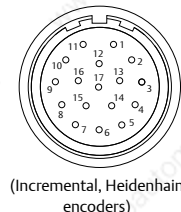

# Cable Selection – NT Motors to Drives

## Power Cable Options: Motor to SP/DST/EP

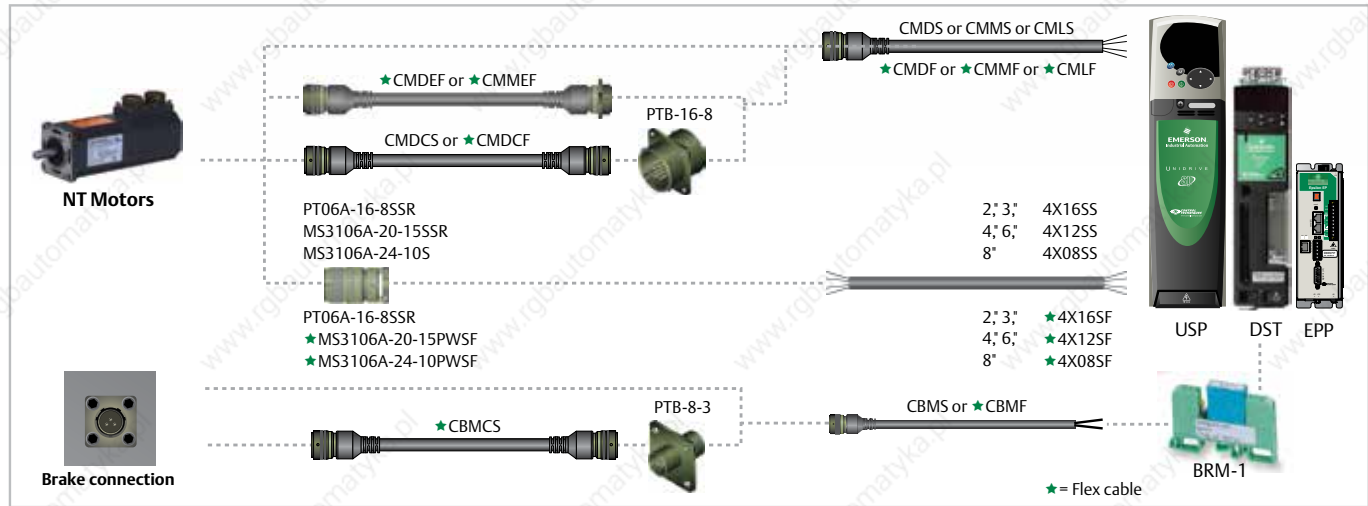

Part Number	Standard Lengths (ft)	Description – Power Cables and Connectors
CMDS	-005, -015, -025, -050, -100	Molded cable, 16 AWG for 2" and 3" motors: connector on motor end, ferrules on drive end; IP-65 shielded connector
CMMS	-005, -015, -025, -050, -100	Molded cable, 12 AWG for 4" and 6" motors, connector on motor end, ferrules on drive end; IP-65 shielded connector
CMLS	-005, -015, -025, -050, -100	Molded cable, 8 AWG for 8" motors, connector on motor end, ferrules on drive end; IP-65 shielded connector
CMDCS*	—	Molded cable, connects to bulkhead on one end, motor connector on the other end for 2" and 3" motors
★CMDF	-005, -015, -025	Molded flex cable, connector at motor end for 2" and 3" motors; min. bend radius 5.6"
★CMMF	-005, -015, -025	Molded flex cable, connectors at both ends for 4" and 6" motors; min. bend radius 9.0" flexing, 6" stationary
★CMLF	-005, -015, -025	Molded flex cable, connector at motor end for 8" motors; min. bend radius 9" flexing, 6" for stationary
★CMDEF	-005, -015, -025	Molded flex extension cable, connectors at both ends for 2" and 3" motors; min. bend radius 5.6"
★CMMEF	-005, -015, -025	Molded flex cable, connectors at both ends for 4" and 6" motors; min. bend radius 9.0" flexing, 6" stationary
★CMDCF*	—	Flex cable, connects bulkhead on one end, motor on the other for 2" and 3" motors; min. bend radius 5.6"
4X08SS	—	Cable for 8" motors, 4-wire, 8AWG w/shield; 0.480" (12.2mm) diameter
4X12SS	—	Cable for 4" and 6" motors, 4-wire 12AWG w/shield; 0.440" (11.2mm) diameter
4X16SS	—	Cable for 2" and 3" motors, 4-wire, 16 AWG w/shield; 0.380" (9.7mm) diameter
★4X16SF	—	Flex cable for 2" and 3" motors, 4-wire, 16AWG, w/shield; min. bend radius 5.6"
★4X12SF	—	Flex cable for 4" and 6" motors, 4-wire, 12AWG, w/shield; min. bend radius 9.0"
★4X08SF	—	Flex cable for 8" motors, 4-wire, 8AWG, min. bend radius 9.2" for flexing
PT06A-16-8SSR	—	Motor power connector for 2" and 3" NT motors, female, not IP-65, not shielded, flex or non-flex cable
★PT06E-16-8SWSF	—	Motor end power cable, female, w/backshell, IP-65, IP-65 shielded connector for 2" and 3" motors
★PT01E-16-8PWSF	—	Extension (male) mates with motor end of motor cable; IP-65, shielded, for 2" and 3" motors
MS3106A-20-15SSR	—	Motor power connector for 4" and 6" NT motors, female, not IP-65, not shielded
★MS3106A-20-15SWSF	—	4" motor power connector, female, not IP-65 shielded
★MS3101A-20-15PWSF	—	Power cable extension plug for 4" motors, male; mates with motor end of motor cable (not shown above)
PTB-16-8	—	Motor bulkhead connector for 2" and 3" motors
Part Number	Standard Lengths (ft)	Description – Brake Cables and Connectors
CBMS	-005, -015, -025, -050, -100	Molded cable, standard duty, connector at motor only
★CBMF	-005, -015, -025, -050, -100	Flex cable, connector at drive, leads at motor; IP-65 shielded connector for 2", 3", 4", 6" motors; min. bend radius 3"
★CBMCS	—	Cable to be connected to bulkhead connector on one end and motor connector on the other end
PT06A-8-3SSR	—	Brake connector kit (not shown above)
PTB-8-3	—	Brake bulkhead connector
BRM-1	—	Brake relay module, 24V, 1 contract, 6A, DIN rail mounting

NOTE:

\*Custom lengths available in 5ft increments



# Cable Selection – NT Motors to Drives

## Feedback Cable Options: Motor to SP/DST/EP – Incremental Encoders

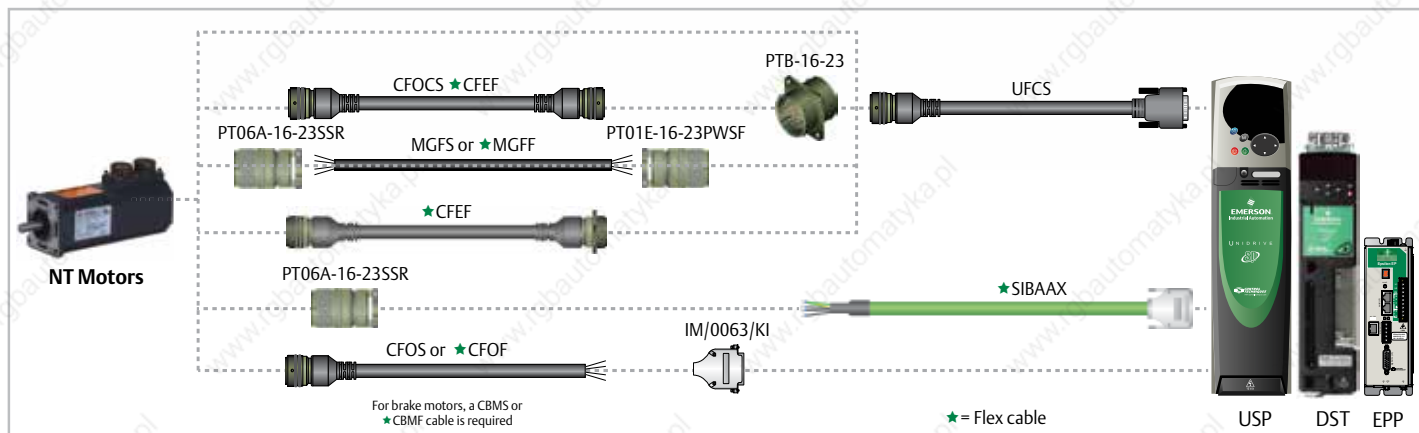

Part Number	Standard Lengths (ft)	Description – Feedback Cables and Connectors
UFCS	-005, -015, -025, -050, -100	Molded cable, connector both ends
MGFS	*	Standard duty cable for 2" and 3" motors, 8-pair with shield
★MGFF	*	Flex cable for 2" and 3" motors, 8 pair with shield; min. bend radius 5.6" for flexing, 10 million cycles
CFOCS	*	Molded extension cable, connects to bulkhead on one end, motor connector on the other end
★CFCF	-005, -015, -025, -050, -100	Flex duty feedback cable for use with PTB-16-23 bulkhead connector, min. bend radius: 5.6" flexing, 10 million cycles
★CFEF	-005, -015, -025, -050, -100	Flex extension cable for encoder feedback motors w/circ. connectors both ends; min. bend radius: 5.6" flexing, 10 million cycles
CFOF	-005, -015, -025, -050, -100	Flex motor feedback cable, connector at motor end only; min. bend radius 5.6" for flexing, 10 million cycles
CFOS	-005, -015, -025, -050, -100	Motor feedback cable, connector at motor only
PT06A-16-23SSR	—	Female connector for motor feedback cable, not IP-65, not shielded
★PT01E-16-23PWSF	—	Male connector for standard motor feedback cable, use at enclosure end with PTB-16-23, IP-65 shielded connector
PTB-16-23	—	Through-the-wall bulkhead connector for feedback cables
★SIBAAX	Lengths are in meters	Incremental feedback cable, connector drive end, high density 15-pin
IM/0063/KI	—	High density 15-pin connector, motor feedback connector on SP,DST, EP
Part Number	Standard Lengths (m)	Description – Encoder Breakout Board
STI-ENC	—	Epsilon EP drive encoder breakout PCB, push-in terminals
SM-ECT	—	Unidrive SP, Digitax ST drives encoder breakout PCB, screw terminals

NOTE:

\*Custom lengths available in 5-ft increments

# Cable Selection – XV Motors to Drives

## XV Motor Cables

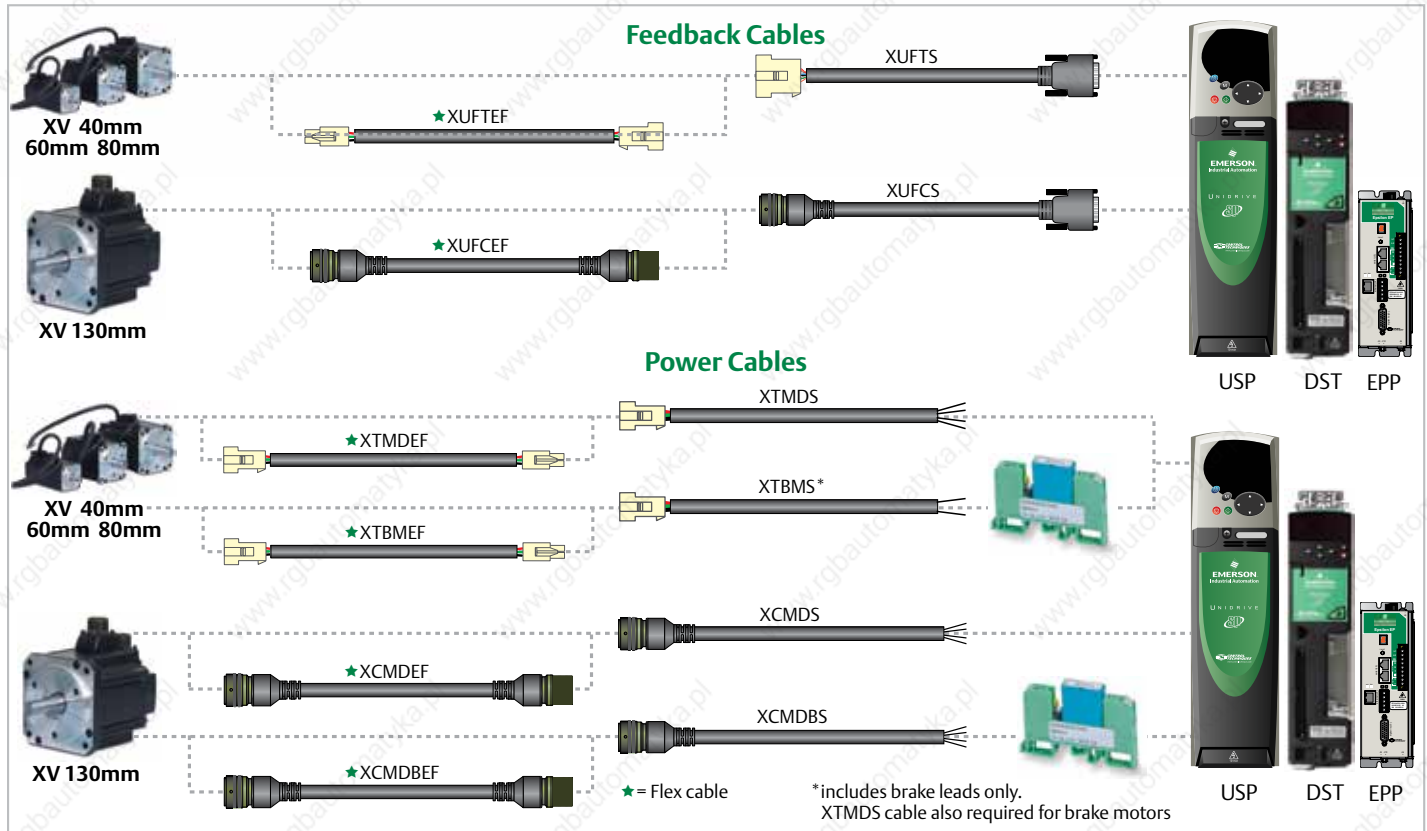

Part Number	Standard Lengths (ft)	Description – Feedback Cables and Connectors
XUFCS	-005, -015, -025, -050, -100	XV Motor feedback cable.
XUFTS	-005, -015, -025, -050, -100	XV 40, 60, 80mm motor to DSUB connector on drive end; 15-pin, high density socket.
XUFTEF	-005, -015, -025, -050	Flex extension feedback cable for XV 40, 60, 80mm motor frames, connectors on both ends; bend radius: 5.6" flexing
XUFCEF	-005, -015, -025, -050	Flex extension feedback cable for XV 130mm motor frames, connectors on both ends; bend radius: 5.6" flexing
Part Number	Standard Lengths (ft)	Description – Power Cables
XCMDS	-005, -015, -025	Motor power cable
XTMD5	-005, -015, -025, -050, -100	Motor power cable
Part Number	Standard Lengths (ft)	Description – Power (Flex) Cables
XCMDEF	-005, -015, -025	Flex motor power cable extension. For use with XCMDS; min. bend radius 5.6"
XTMEF	-005, -015, -025	Flex motor power cable extension. For use with XTMD5; min. bend radius 5.6"
XTBMEF	-005, -015, -025, -050	Flex duty brake cable for XV 40, 60, 80mm motor frames; TBNS male connector to TBNS female connector; designed as extension of XCMDS cable
XCMDBS	-005, -015, -025, -050	Flex duty brake cable for XV 40, 60, 80mm motor frames. TBNS male connector to TBNS female connector; designed as extension of XCMDS cable
Part Number	Standard Lengths (ft)	Description – Brake Cables
XTBMS	-005, -015, -025, -050, -100	Motor brake cable, standard duty, connector at motor only
Part Number	Standard Lengths (ft)	Description – Brake (Flex) Cable and Connectors
XCMDBEF	-005, -015, -025	Flex motor brake cable extension for use with XCMDBS; min. bend radius 5.6"

## Unimotor FM Fan Kits

The FM Servo motors 075 to 190 frames can be field fitted with a cooling fan. These fan kits are intended for use in applications that operate near the thermal limit of the motor. Each FM Motor is thermally protected with an internal winding thermistor. If the motor experiences a thermal trip condition and is found to be operating near the thermal limit, a fan kit may help provide continuous operation during times of high continuous torque output. The motor thermal protection should never be defeated or bypassed as this could cause permanent damage to the motor.

Fan kits are IP20 and include mounting hardware. A terminal box mounted on the top rear of the fan shroud allows connection to the 230V fan leads.



### Unimotor FM Fan Kits

Part Number	Description
075FB21	075 FM Motor Fan Box
095FB21	095 FM Motor Fan Box
115FB21	115 FM Motor Fan Box
142FB21	142 FM Motor Fan Box
190FB21	190 FM Motor Fan Box

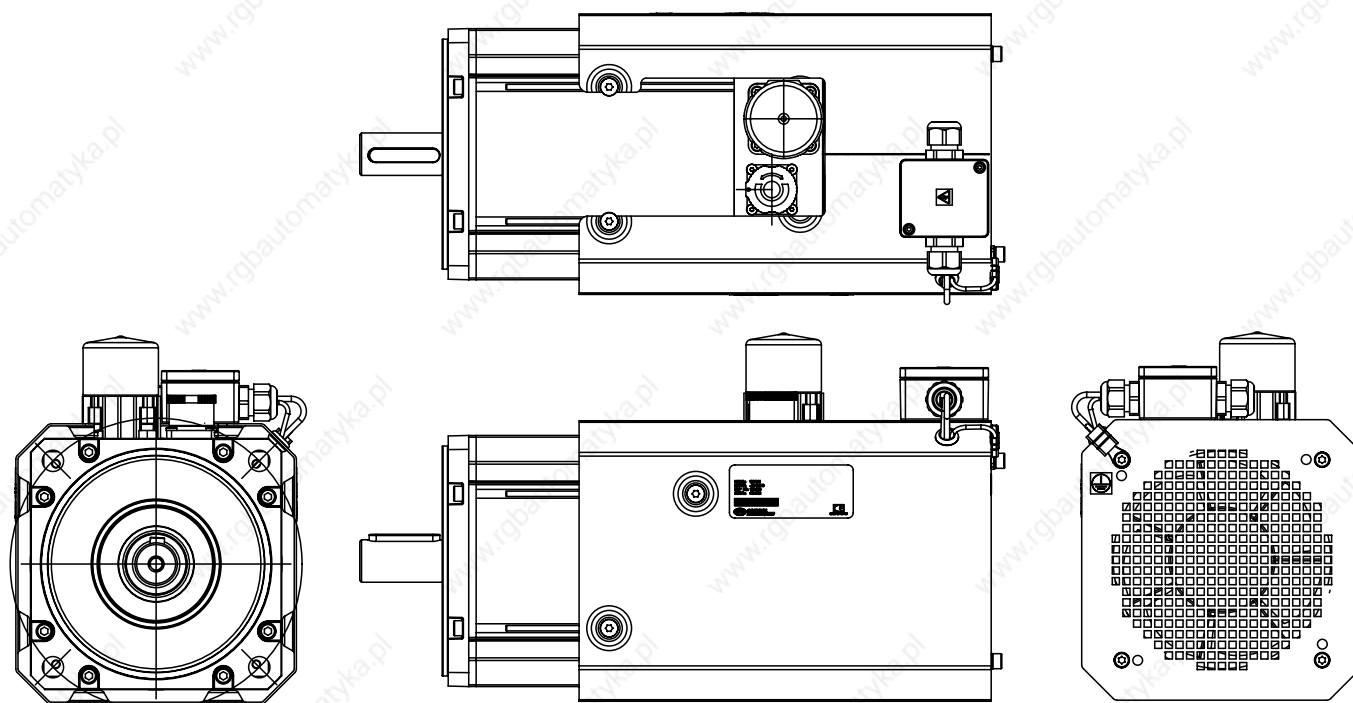

# Driving Technology...



- Drive and Application Centers
- International Distribution Centers

Control Techniques has a network of over 500 hundred distributors in North America. Call for the distributor nearest you.

## AUSTRALIA

Melbourne Application Center  
T: +613 973 81777  
controltechniques.au@emerson.com

Sydney Drive Center  
T: +61 2 9838 7222  
controltechniques.au@emerson.com

## AUSTRIA

Linz Drive Center  
T: +43 7229 789480  
controltechniques.at@emerson.com

## BELGIUM

Brussels Drive Center  
T: +32 1574 0700  
controltechniques.be@emerson.com

## BRAZIL

Sorocaba Drive Center  
T: +55 15 3413 8169  
vendabrasil.cta@emerson.com

## CANADA

Toronto Application Center  
T: +1 905 948 3402  
controltechniques.ca@emerson.com

Calgary Drive Center  
T: +1 403 253 8738  
controltechniques.ca@emerson.com

## CHILE

Santiago Application Center  
T: +56 9 7708 9470  
saleschile.cta@emerson.com

## CHINA

Shanghai Drive Center  
T: +86 21 3418 3888  
controltechniques.cn@emerson.com

Shenzhen Application Center  
T: +86 755 8618 7287  
controltechniques.cn@emerson.com

## CZECH REPUBLIC

Brno Drive Center  
T: +420 511 180111  
controltechniques.cz@emerson.com

## DENMARK

Copenhagen Drive Center  
T: +45 4369 6100  
controltechniques.dk@emerson.com

## FRANCE\*

Angoulême Drive Center  
T: +33 5 4564 5454  
controltechniques.fr@emerson.com

## GERMANY

Bonn Drive Center  
T: +49 2242 8770  
controltechniques.de@emerson.com

Chemnitz Drive Center  
T: +49 3722 52030  
controltechniques.de@emerson.com

Darmstadt Drive Center  
T: +49 6251 17700  
controltechniques.de@emerson.com

## GREECE\*

Athens Application Center  
T: +0030 210 57 86086/088  
controltechniques.gr@emerson.com

## HOLLAND

Rotterdam Drive Center  
T: +31 184 420555  
controltechniques.nl@emerson.com

## INDIA

Chennai Drive Center  
T: +91 44 2496 1123/1130/1083  
T: +91 44 6691 8400  
controltechniques.in@emerson.com

## IRELAND

Newbridge Drive Center  
T: +353 45 448200  
controltechniques.ie@emerson.com

## ITALY

Milan Drive Center  
T: +39 02575 751  
controltechniques.it@emerson.com

Vicenza Drive Center  
T: +39 0444 933400  
controltechniques.it@emerson.com

## MALAYSIA

Kuala Lumpur Drive Center  
T: +603 5634 9776  
controltechniques.my@emerson.com

## MEXICO

Mexico City Application Center  
T: +52 155 3333 6666  
salesmexico.cta@emerson.com

## POLAND

Warsaw Application Center  
T: +48 22 45 89 200  
controltechniques.pl@emerson.com

## REPUBLIC OF SOUTH AFRICA

Johannesburg Drive Center  
T: +27 11 462 1740  
controltechniques.za@emerson.com

Cape Town Application Center  
T: +27 21 556 0245  
controltechniques.za@emerson.com

## RUSSIA

Moscow Application Center  
T: +7 495 981 9811  
controltechniques.ru@emerson.com

## SINGAPORE

Singapore Drive Center  
T: +65 6891 7600  
controltechniques.sg@emerson.com

## SLOVAKIA EMERSON A.S

T: +421 32 7700 369  
controltechniques.sk@emerson.com

## SOUTH KOREA

Seoul Application Center  
T: +82 2 3483 1605  
controltechniques.kr@emerson.com

## SPAIN

Barcelona Drive Center  
T: +34 93 680 1661  
controltechniques.es@emerson.com

## Bilbao Drive Center

T: +34 94 620 3646  
controltechniques.es@emerson.com

Madrid Application Centre  
T: +34 91 490 21 05  
controltechniques.es@emerson.com

Valencia Drive Center  
T: +34 96 154 2900  
controltechniques.es@emerson.com

SWEDEN\*  
Stockholm Application Center  
T: +468 554 241 00  
controltechniques.se@emerson.com

SWITZERLAND  
Zurich Drive Center  
T: +41 56 201 4242  
controltechniques.ch@emerson.com

Lausanne Application Center  
T: +41 21 637 7070  
controltechniques.fr.ch@emerson.com

TAIWAN  
Taipei Application Center  
T: +886 2 8161 7695  
controltechniques.tw@emerson.com

THAILAND  
Bangkok Drive Center  
T: +66 2 962 2099  
controltechniques.th@emerson.com

TURKEY  
Istanbul Drive Center  
T: +90 216 4182420  
controltechniques.tr@emerson.com

TURKEY  
Istanbul Drive Center  
T: +90 216 4182420  
controltechniques.tr@emerson.com

UAE\*  
Emerson FZE  
T: +971 4 8118100  
ct.dubai@emerson.com

UNITED KINGDOM  
Telford Drive Center  
T: +44 1952 213700  
controltechniques.uk@emerson.com

UNITED KINGDOM  
Telford Drive Center  
T: +44 1952 213700  
controltechniques.uk@emerson.com

\*Operated by sister company, Leroy Somer®