

UV A Light Sensor with I²C Interface

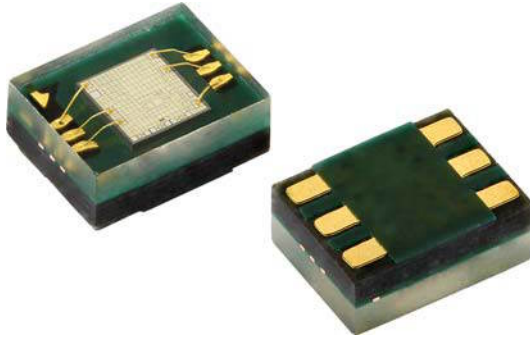

DESCRIPTION

VEML6070 is an advanced ultraviolet (UV) light sensor with I²C protocol interface and designed by the CMOS process. It is easily operated via a simple I²C command. The active acknowledge (ACK) feature with threshold windows setting allows the UV sensor to send out a UVI alert message. Under a strong solar UVI condition, the smart ACK signal can be easily implemented by the software programming.

VEML6070 incorporates a photodiode, amplifiers, and analog / digital circuits into a single chip. VEML6070's adoption of Filtron™ UV technology provides the best spectral sensitivity to cover UV spectrum sensing. It has an excellent temperature compensation and a robust refresh rate setting that does not use an external RC low pass filter. VEML6070 has linear sensitivity to solar UV light and is easily adjusted by an external resistor. Software shutdown mode is provided, which reduces power consumption to be less than 1 μA. VEML6070's operating voltage ranges from 2.7 V to 5.5 V.

FEATURES

- Package type: surface mount
- Dimensions (L x W x H in mm): 2.35 x 1.8 x 1.0
- Integrated modules: ultraviolet sensor (UV), and signal conditioning IC
- Converts solar UV light intensity to digital data
- Excellent UV sensitivity and linearity via Filtron™ technology
- Excellent performance of UV radiation measurement under long time solar UV exposure
- Excellent temperature compensation
- High dynamic detection resolution
- Standard I²C protocol interface
- Support acknowledge feature (ACK)
- Immunity on fluorescent light flicker software shutdown mode control
- Package: OPLGA
- Temperature compensation: -40 °C to +85 °C
- Floor life: 168 h, MSL 3, according to J-STD-020
- Output type: I²C bus
- Operation voltage: 2.7 V to 5.5 V
- Material categorization: for definitions of compliance please see www.vishay.com/doc?99912



APPLICATIONS

- Solar UV indicator
- Cosmetic / outdoor sport handheld product
- Consumer products

PRODUCT SUMMARY

PART NUMBER	OPERATING VOLTAGE RANGE (V)	I ² C BUS VOLTAGE RANGE (V)	PEAK SENSITIVITY (nm)	RANGE OF SPECTRAL BANDWIDTH λ _{0.5} (nm)	OUTPUT CODE
VEML6070	2.7 to 5.5	1.7 to 5.5	355	± 20	16 bit, I ² C

Note

(1) Adjustable through I²C interface

ORDERING INFORMATION

ORDERING CODE	PACKAGING	VOLUME (1)	REMARKS
VEML6070	Tape and reel	MOQ: 2500 pcs	2.35 mm x 1.8 mm x 1.0 mm

Note

(1) MOQ: minimum order quantity

ABSOLUTE MAXIMUM RATINGS (T_{amb} = 25 °C, unless otherwise specified)

PARAMETER	TEST CONDITION	SYMBOL	MIN.	MAX.	UNIT
Supply voltage		V _{DD}	0	6.0	V
Operation temperature range		T _{amb}	-40	+85	°C

RECOMMENDED OPERATING CONDITIONS ($T_{amb} = 25\text{ }^{\circ}\text{C}$, unless otherwise specified)					
PARAMETER	TEST CONDITION	SYMBOL	MIN.	MAX.	UNIT
Supply voltage		V_{DD}	2.7	5.5	V
Operation temperature range		T_{amb}	-40	+85	$^{\circ}\text{C}$
I ² C bus operating frequency		$f_{(I2CCLK)}$	10	400	kHz

PIN DESCRIPTIONS			
PIN ASSIGNMENT	SYMBOL	TYPE	FUNCTION
1	GND	I	Power supply ground, all voltage are reference to GND
2	ACK	O (open drain)	Acknowledge pin
3	SDA	I / O (open drain)	I ² C digital serial data output to the host
4	SET		Light reading adjustment, connect a resistor to GND
5	SCL	I	I ² C digital serial clock input from the host
6	V_{DD}	I	Supply voltage

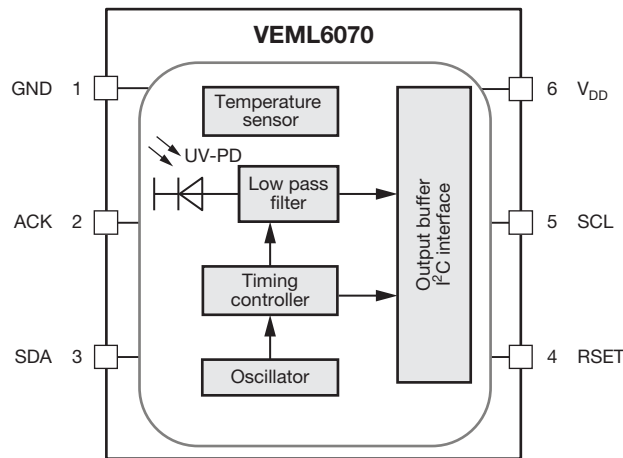
BLOCK DIAGRAM

BASIC CHARACTERISTICS ($T_{amb} = 25\text{ }^{\circ}\text{C}$, unless otherwise specified)							
PARAMETER	TEST CONDITION	SYMBOL	MIN.	TYP.	MAX.	UNIT	
Supply operation voltage		V_{DD}	2.7	-	5.5	V	
Supply current	$R_{SET} = 240\text{ k}\Omega$ (1)(2)	I_{DD}	-	100	250	μA	
I ² C signal input	Logic high	(1)(2)	V_{IH}	1.5	-	V_{DD}	V
	Logic low		V_{IL}	-	-	0.8	
Peak sensitivity wavelength		λ_p	-	355	-	nm	
Range of spectral sensitivity		$\lambda_{0.1}$	320	-	410	nm	
UVA sensitivity	$R_{SET} = 240\text{ k}\Omega$, $I_T = 1\text{ T}$ (3)		-	5	-	$\mu\text{W}/\text{cm}^2/\text{step}$	
Maximum UVA detection power	$R_{SET} = 240\text{ k}\Omega$, $I_T = 1\text{ T}$ (3)		-	-	328	mW/cm^2	
Dark offset	$R_{SET} = 240\text{ k}\Omega$, $I_T = 1\text{ T}$ (1)		0	1	5	steps	
Output offset	$R_{SET} = 240\text{ k}\Omega$, $I_T = 1\text{ T}$ (1)(4)		-	2	-	steps	
Shutdown current	Light condition = dark (1)	I_{DD}	-	1	15	μA	

Notes

- (1) Test condition: $V_{DD} = 3.3\text{ V}$, temperature: $25\text{ }^{\circ}\text{C}$
- (2) Light source: solar light source
- (3) Test using 365 nm UVA LED
- (4) Ambient light intensity = 500 lx