

PROXIMITY/UV/AMBIENT LIGHT SENSOR MODULE WITH I²C INTERFACE

Features

- Integrated infrared proximity detector
 - Proximity detection adjustable from under 1 cm to over 50 cm
 - Three independent LED drivers
 - 15 current settings from 5.6 mA to 360 mA for each LED driver
 - 25.6 μ s LED driver pulse width
 - 50 cm proximity range with single pulse (<3 klx)
 - 15 cm proximity range with single pulse (>3 klx)
 - Operates at up to 128 klx (direct sunlight)
 - High reflectance sensitivity < 1 μ W/cm²
 - High EMI immunity without shielded packaging
- Integrated UV index sensor
- Integrated ambient light sensor
 - 100 mlx resolution possible, allowing operation under dark glass
 - 1 to 128 klx dynamic range possible across two ADC range settings
- Accurate lux measurements with IR correction algorithm
- Industry's lowest power consumption
 - 1.71 to 3.6 V supply voltage
 - 9 μ A average current (LED pulsed 25.6 μ s every 800 ms at 180 mA plus 3 μ A Si1145/46/47-M01 supply)
 - < 500 nA standby current
 - Internal and external wake support
 - Built-in voltage supply monitor and power-on reset controller
 - 25.6 μ s LED "on" time keeps total power consumption duty cycle low without compromising performance or noise immunity
- IR LED integrated inside the module
- I²C Serial communications
 - Up to 3.4 Mbps data rate
 - Slave mode hardware address decoding (0x60)
- Small-outline 10-lead 4.9x2.85x1.2 mm QFN
- Temperature Range
 - -40 to +85 °C

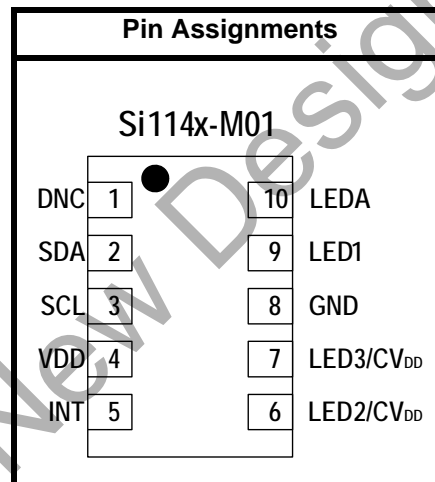

Applications

- Handsets
- Heart rate monitoring
- Pulse oximetry
- Wearables
- E-book readers
- Notebooks/Netbooks
- Portable consumer electronics
- Touchless switches
- Touchless sliders
- Consumer electronics
- Display backlighting control

Description

The Si1145/46/47-M01 is a low-power, reflectance-based, proximity, UV Index and ambient light module with integrated single IR LED, two additional LED driver outputs, I²C digital interface, and programmable-event interrupt output. This touchless sensor module includes an analog-to-digital converter, integrated high-sensitivity visible and infrared photodiodes, digital signal processor, and three integrated infrared LED drivers with fifteen selectable drive levels. The Si1145/46/47-M01 offers excellent performance under a wide dynamic range and a variety of light sources including direct sunlight. The Si1145/46/47-M01 can also work under dark glass covers. The photodiode response and associated digital conversion circuitry provide excellent immunity to artificial light flicker noise and natural light flutter noise. With two or more LEDs, the Si1145/46/47-M01 is capable of supporting multiple-axis proximity motion detection. The Si1145/46/47-M01 devices are provided in a 10-lead 4.9x2.85x1.2 mm QFN package and are capable of operation from 1.71 to 3.6 V over the -40 to +85 °C temperature range.

Si1145/46/47-M01

Functional Block Diagram

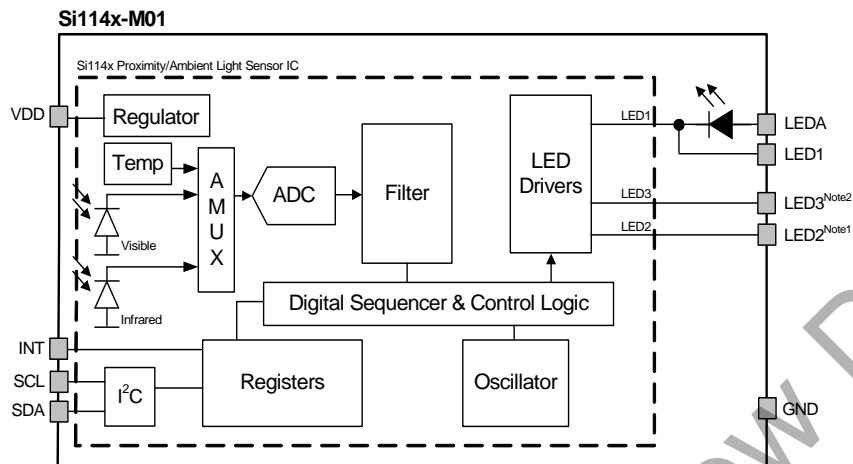

Notes:

1. Si1146-M01 and Si1147-M01 only. Must be tied to V_{DD} with Si1145-M01.
2. Si1147-M01 only. Must be tied to V_{DD} with Si1145-M01 and Si1146-M01.

Figure 1. Si114x-M01 Sensor Module

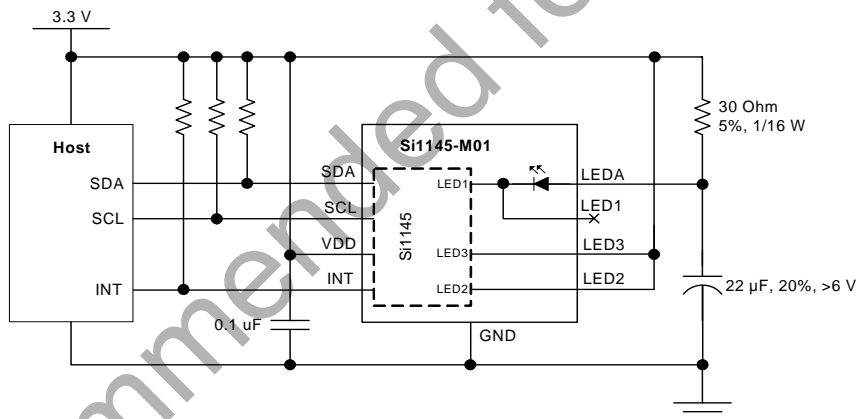

Figure 2. Si1145-M01 Module Basic Application Schematic for 1 LED