

SIEMENS

SIMOVERT MASTERDRIVES Motion Control

Betriebsanleitung
Operating Instructions

Wechselrichter (DC-AC) Bauform Kompakt PLUS
Frequency Inverter (DC-AC) Compact PLUS Type

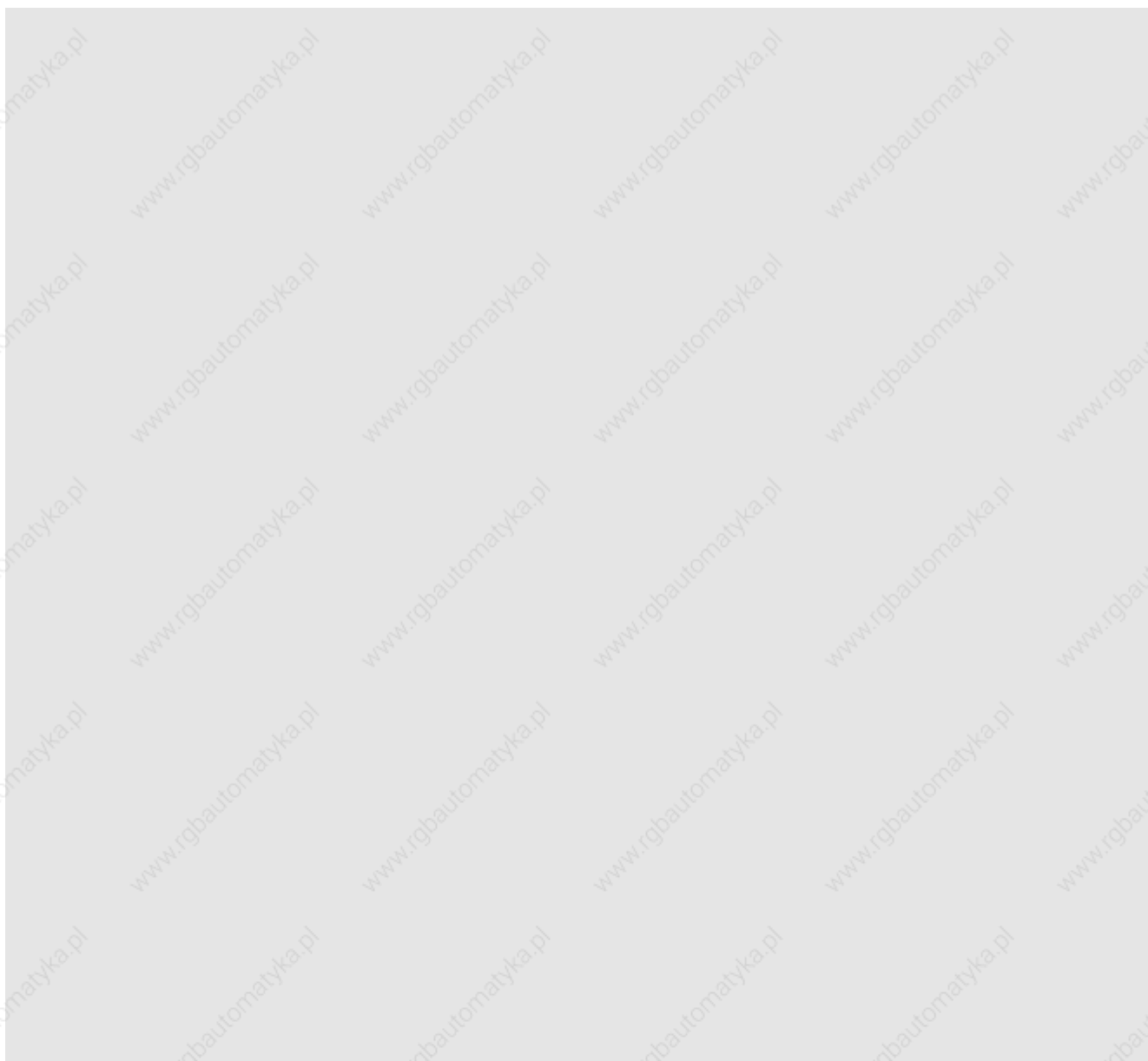

Diese Betriebsanleitung gilt für den Gerätesoftwarestand V 1.2.

Änderungen von Funktionen, technischen Daten, Normen, Zeichnungen und Parametern vorbehalten.

These Operating Instructions are valid for software release V 1.2.

We reserve the right to make changes to functions, technical data, standards, drawings and parameters.

Weitergabe sowie Vervielfältigung dieser Unterlage, Verwertung und Mitteilung ihres Inhalts nicht gestattet, soweit nicht ausdrücklich zugestanden. Zuwiderhandlungen verpflichten zu Schadenersatz. Alle Rechte vorbehalten, insbesondere für den Fall der Patenterteilung oder GM-Eintragung.

Wir haben den Inhalt der Druckschrift auf Übereinstimmung mit der beschriebenen Hard- und Software überprüft. Dennoch können Abweichungen nicht ausgeschlossen werden, so daß wir für die vollständige Übereinstimmung keine Garantie übernehmen. Die Angaben in dieser Druckschrift werden jedoch regelmäßig überprüft und notwendige Korrekturen sind in den nachfolgenden Auflagen enthalten. Für Verbesserungsvorschläge sind wir dankbar

The reproduction, transmission or use of this document or its contents is not permitted without express written authority. Offenders will be liable for damages. All rights, including rights created by patent grant or registration of a utility model or design, are reserved.

We have checked the contents of this document to ensure that they coincide with the described hardware and software. However, differences cannot be completely excluded, so that we do not accept any guarantee for complete conformance. However, the information in this document is regularly checked and necessary corrections will be included in subsequent editions. We are grateful for any recommendations for improvement.

SIMOVERT® ist ein Warenzeichen von Siemens

SIMOVERT® Registered Trade Mark

Contents

1	DEFINITIONS AND WARNINGS	1-1
2	DESCRIPTION	2-1
3	FIRST START-UP	3-1
4	TRANSPORT, STORAGE, UNPACKING.....	4-1
5	INSTALLATION.....	5-1
5.1	Installing the units	5-1
5.2	Installing the optional boards	5-4
5.2.1	Installing optional boards on units with a width up to 90 mm	5-4
5.2.2	Installing optional boards on units with a width of 135 mm and 180 mm	5-7
6	INSTALLATION IN CONFORMANCE WITH EMC REGULATIONS	6-1
7	CONNECTING-UP.....	7-1
7.1	Power connections.....	7-4
7.1.1	Power connections for units with a width up to 90 mm.....	7-5
7.1.2	Power connections for units with a width of 135 mm and 180 mm	7-6
7.2	Control connections	7-7
8	PARAMETERIZATION.....	8-1
8.1	Parameter input via the PMU.....	8-2
8.2	Parameter input via the OP1S	8-5
8.3	Parameter reset to factory setting.....	8-9
8.4	Parameterizing by download.....	8-10
8.5	Parameterizing with parameter modules	8-11
8.6	Complete parameterization.....	8-27

9	MAINTENANCE	9-1
9.1	Replacing the fan	9-2
9.1.1	Replacing the fan in units up to 90 mm wide	9-2
9.1.2	Replacing the fan in units 135 mm wide	9-2
9.1.3	Replacing the fan in units up to 180 mm wide	9-3
10	FORMING	10-1
11	TECHNICAL DATA	11-1
12	FAULTS AND ALARMS.....	12-1
12.1	Faults	12-1
12.2	Alarms.....	12-11
12.3	Fatal errors (FF).....	12-31
13	ENVIRONMENTAL FRIENDLINESS	13-1
14	CERTIFICATES.....	14-1

1 Definitions and Warnings

Qualified personnel For the purpose of this documentation and the product warning labels, a "Qualified person" is someone who is familiar with the installation, mounting, start-up, operation and maintenance of the product. He or she must have the following qualifications:

- ◆ Trained or authorized to energize, de-energize, ground and tag circuits and equipment in accordance with established safety procedures.
- ◆ Trained or authorized in the proper care and use of protective equipment in accordance with established safety procedures.
- ◆ Trained in rendering first aid.

DANGER



For the purpose of this documentation and the product warning labels, "Danger" indicates death, severe personal injury or substantial property damage will result if proper precautions are not taken.

WARNING



For the purpose of this documentation and the product warning labels, "Warning" indicates death, severe personal injury or property damage can result if proper precautions are not taken.

CAUTION



For the purpose of this documentation and the product warning labels, "Caution" indicates that minor personal injury or material damage can result if proper precautions are not taken.

NOTE

For the purpose of this documentation, "Note" indicates important information about the product or about the respective part of the documentation which is essential to highlight.

WARNING

Hazardous voltages are present in this electrical equipment during operation.

Non-observance of the warnings can thus result in severe personal injury or property damage.

Only qualified personnel should work on or around the equipment

This personnel must be thoroughly familiar with all warning and maintenance procedures contained in this documentation.

The successful and safe operation of this equipment is dependent on correct transport, proper storage and installation as well as careful operation and maintenance.

NOTE

This documentation does not purport to cover all details on all types of the product, nor to provide for every possible contingency to be met in connection with installation, operation or maintenance.

Should further information be desired or should particular problems arise which are not covered sufficiently for the purchaser's purposes, the matter should be referred to the local SIEMENS sales office.

The contents of this documentation shall not become part of or modify any prior or existing agreement, commitment or relationship. The sales contract contains the entire obligation of SIEMENS AG. The warranty contained in the contract between the parties is the sole warranty of SIEMENS AG. Any statements contained herein do not create new warranties or modify the existing warranty.

CAUTION

Components which can be destroyed by electrostatic discharge (ESD)

The board contains components which can be destroyed by electrostatic discharge. These components can be easily destroyed if not carefully handled. If you have to handle electronic boards, please observe the following:

Electronic boards should only be touched when absolutely necessary.

The human body must be electrically discharged before touching an electronic board.

Boards must not come into contact with highly insulating materials - e.g. plastic parts, insulated desktops, articles of clothing manufactured from man-made fibers.

Boards must only be placed on conductive surfaces.

Boards and components should only be stored and transported in conductive packaging (e.g. metalized plastic boxes or metal containers).

If the packing material is not conductive, the boards must be wrapped with a conductive packaging material, e.g. conductive foam rubber or household aluminium foil.

The necessary ESD protective measures are clearly shown again in the following diagram:

- ◆ a = Conductive floor surface
- ◆ b = ESD table
- ◆ c = ESD shoes
- ◆ d = ESD overall
- ◆ e = ESD chain
- ◆ f = Cubicle ground connection

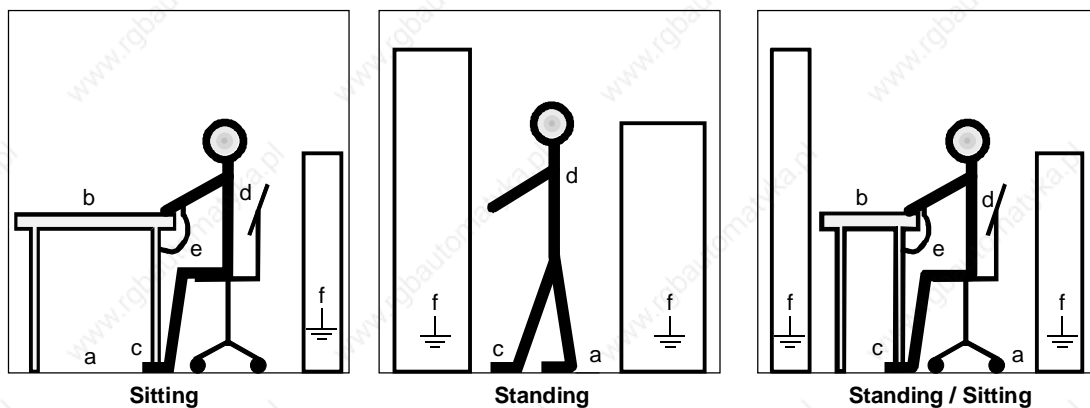

Fig. 1-1

ESD protective measures



Safety and Operating Instructions for Drive Converters

(in conformity with the low-voltage directive 73/23/EEC)

1. General

In operation, drive converters, depending on their degree of protection, may have live, uninsulated, and possibly also moving or rotating parts, as well as hot surfaces.

In case of inadmissible removal of the required covers, of improper use, wrong installation or maloperation, there is the danger of serious personal injury and damage to property.

For further information, see documentation.

All operations serving transport, installation and commissioning as well as maintenance are to be carried out **by skilled technical personnel** (observe IEC 364 or CENELEC HD 384 or DIN VDE 0100 and IEC Report 664 or DIN VDE 0110 and national accident prevention rules).

For the purposes of these basic safety instructions, "skilled technical personnel" means persons who are familiar with the installation, mounting, commissioning and operation of the product and have the qualifications needed for the performance of their functions.

2. Intended use

Drive converters are components designed for inclusion in electrical installations or machinery.

In case of installation in machinery, commissioning of the drive converter (i.e. the starting of normal operation) is prohibited until the machinery has been proved to conform to the provisions of the EC directive 89/392/EEC (Machinery Safety Directive - MSD). Account is to be taken of EN 60204.

Commissioning (i.e. the start of normal operation) is admissible only where conformity with the EMC directive (89/336/EEC) has been established.

The drive converters meet the requirements of the low-voltage directive 73/23/EEC. They are subject to the harmonized standards of the series prEN 50178/DIN VDE 0160 in conjunction with EN 60439-1/DIN VDE 0660 Part 500 and EN 60146/DIN VDE 0558.

The technical data as well as information concerning the supply conditions shall be taken from the rating plate and from the documentation and shall be strictly observed.

3. Transport, storage

The instructions for transport, storage and proper use shall be complied with.

The climatic conditions shall be in conformity with prEN 50178.

4. Installation

The installation and cooling of the appliances shall be in accordance with the specifications in the pertinent documentation.

The drive converters shall be protected against excessive strains. In particular, no components must be bent and/or isolating distances altered in the course of transportation or handling. No contact shall be made with electronic components and contacts.

Drive converters contain electrostatic sensitive components which are liable to damage through improper use. Electronic components must not be mechanically damaged or destroyed (potential health risks).

5. Electrical connection

When working on live drive converters, the applicable national accident prevention rules (e.g. VBG 4) must be complied with.

The electrical installation shall be carried out in accordance with the relevant requirements (e.g. cross-sectional areas of conductors, fusing, PE connection). For further information, see documentation.

Instructions for the installation in accordance with EMC requirements, such as screening, grounding, location of filters and wiring, are contained in the drive converter documentation. They must always be complied with, also for drive converters bearing a CE marking. Observance of the limit values required by the EMC law is the responsibility of the manufacturer of the installation or machine.

6. Operation

Installations which include drive converters shall be equipped with additional monitoring and protective devices in accordance with the relevant applicable safety requirements, e.g. Act respecting technical equipment, accident prevention rules, etc. Changes to the drive converters by means of the operating software are permissible.

After disconnection of the drive converters from the voltage supply, live appliance parts and power terminals must not be touched immediately because of possibly energized capacitors. In this regard, the corresponding signs and markings on the drive converter must be respected.

During operation, all covers and doors shall be kept closed.

7. Maintenance and servicing

The manufacturer's documentation shall be followed.

Keep these safety instructions in a safe place!

2 Description

Range of application The inverter is a power electronics component for feeding highly dynamic three-phase drives in the output range from 0.75 kW to 18.5 kW.

The unit can be operated from a DC system with voltages from 510 V to 650 V.

The inverter enables a three-phase system with a variable output frequency between 0 Hz and 400 Hz to be generated from the DC link voltage with the pulse width modulation method (PWM).

The unit is controlled by the internal closed-loop control electronics which consists of a microprocessor and a digital signal processor (DSP). The functions are provided by the unit software.

The unit can be operated via the PMU operator control panel, the user-friendly OP1S operator control panel, the terminal strip or via the bus system. For this purpose, the unit has a number of interfaces and three slots for the use of optional boards.

Resolvers, encoders, pulse encoders and multitrans encoders can be used as encoders on the motor.

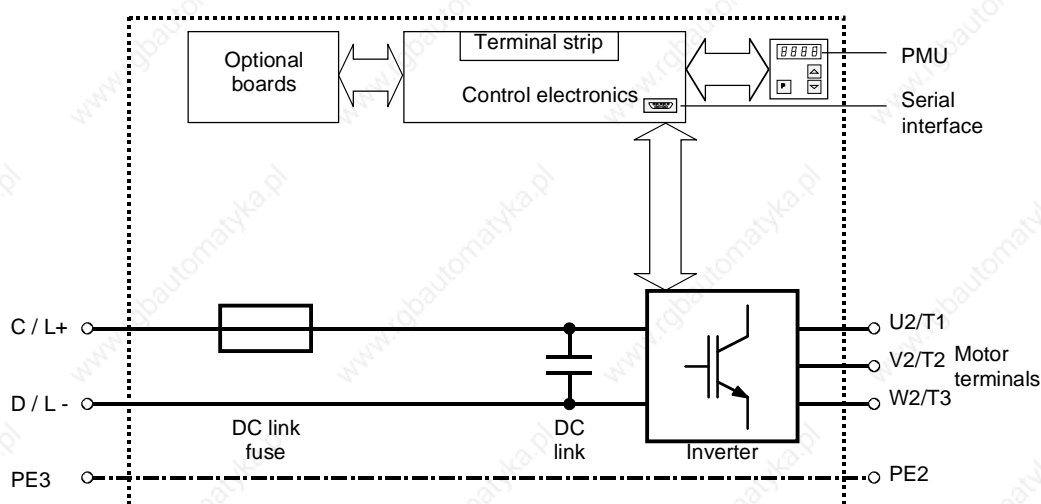
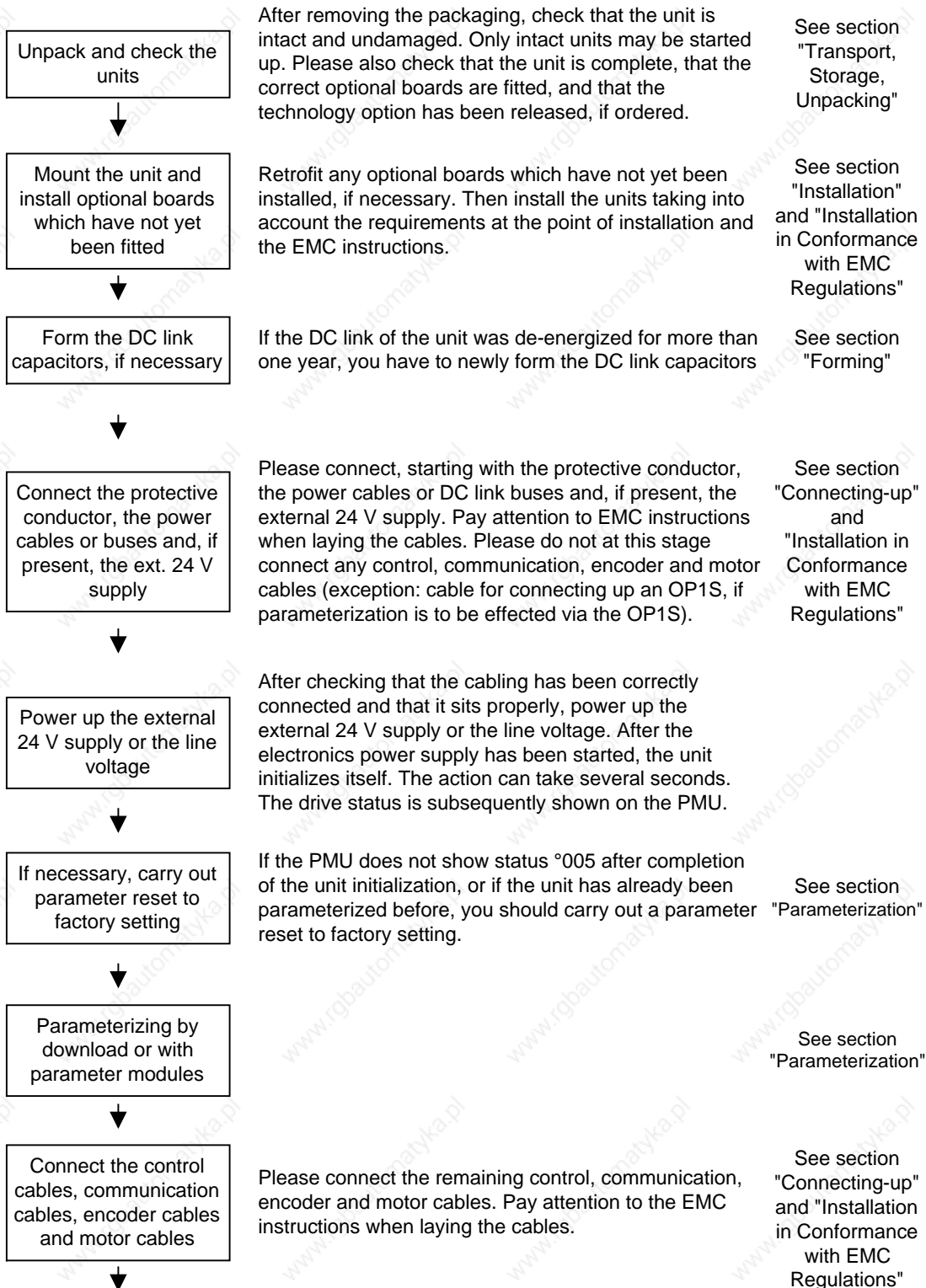
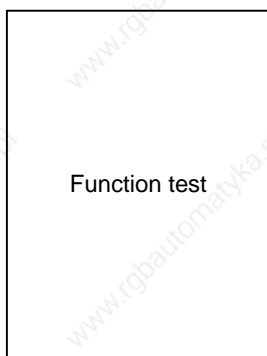

Fig. 2-1 Circuit principle of the inverter

3 First Start-up





After checking the unit and the cabling once more, power up the line voltage or DC bus voltage, if you have not already done so, and perform a function test according to your parameterization.

WARNING

It must be ensured that no danger for persons and equipment can occur by energizing the power and the unit. It is recommended not to couple the driven machine until the function test has been successfully completed.

Further start-up and parameterization according to your specific requirements

4 Transport, Storage, Unpacking

The units and components are packed in the manufacturing plant corresponding to that specified when ordered. A packing label is located on the outside of the packaging. Please observe the instructions on the packaging for transport, storage and professional handling.

Transport

Vibrations and jolts must be avoided during transport. If the unit is damaged, you must inform your shipping company immediately.

Storage

The units and components must be stored in clean, dry rooms. Temperatures between -25 °C (-13 °F) and +70 °C (158 °F) are permissible. Temperature fluctuations must not be more than 30 K per hour.

NOTE

If the storage period of one year is exceeded, the unit must be newly formed. See Section "Forming".

Unpacking

The packaging comprises board and corrugated paper. It can be disposed of corresponding to the appropriate local regulations for the disposal of board products. The units and components can be installed and commissioned after they have been unpacked and checked to ensure that everything is complete and that they are not damaged.

5 Installation

5.1 Installing the units

WARNING



Safe converter operation requires that the equipment is mounted and commissioned by qualified personnel taking into account the warning information provided in these Operating Instructions.

The general and domestic installation and safety regulations for work on electrical power equipment (e.g. VDE) must be observed as well as the professional handling of tools and the use of personal protective equipment.

Death, severe bodily injury or significant material damage could result if these instructions are not followed.

Clearances

When you install the equipment, make sure that the DC link connection is at the top and the motor connection is at the bottom.

The devices can be mounted side by side in close physical contact.

In order to ensure an adequate supply of cooling air, a clearance of 100 mm must be left at the top of the unit and at the bottom of the unit respectively to components which may considerably affect the flow of cooling air.

When mounting in cabinets, the cabinet cooling must be designed according to the power loss. Please refer to the Technical Data in this regard.

Requirements at the point of installation

- ◆ Foreign particles
The units must be protected against the ingress of foreign particles as otherwise their function and operational safety cannot be ensured.
- ◆ Dust, gases, vapors
Equipment rooms must be dry and dust-free. Ambient and cooling air must not contain any electrically conductive gases, vapors and dust which could diminish the functionality. If necessary, filters should be used or other corrective measures taken.
- ◆ Cooling air
The units must only be operated in an ambient climate in accordance with DIN IEC 721-3-3 Class 3K3. For cooling air temperatures of more than 45 °C (113 °F) and installation altitudes higher than 1000 m, derating is required.

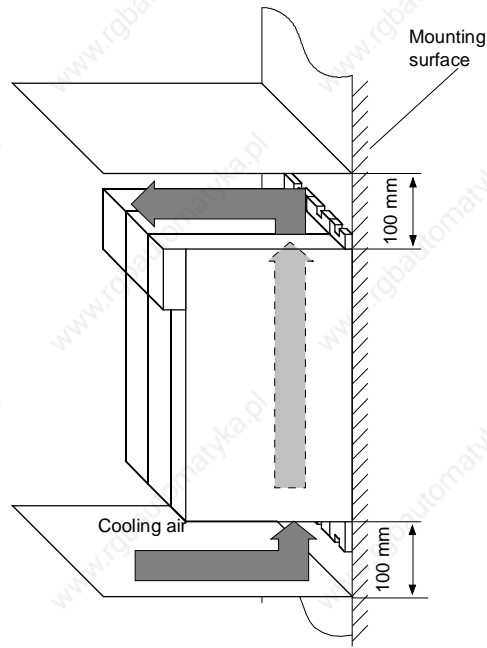

Fig. 5-1 Minimum clearances for cooling

Installation

The unit is mounted directly to a mounting surface. Fixing is by means of two or four M5 screws.

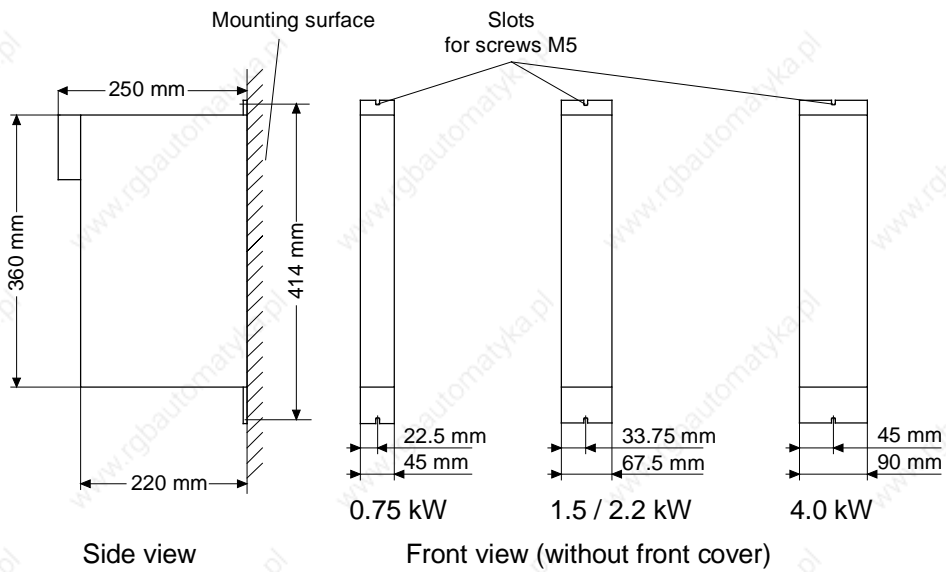

Fig. 5-2 Dimension drawings for housings up to 90 mm wide

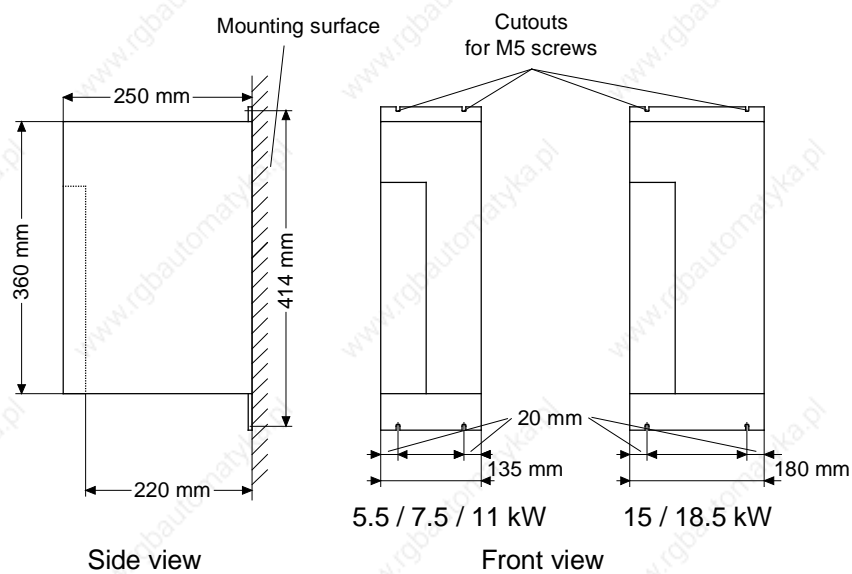

Fig. 5-3 Dimension drawings for housings 135 mm and 180 mm wide

5.2 Installing the optional boards

WARNING



The unit has hazardous voltage levels up to 5 minutes after it has been powered down due to the DC link capacitors. The unit or the DC link terminals must not be worked on until at least after this delay time.

5.2.1 Installing optional boards on units with a width up to 90 mm

Disconnecting the rectifier unit from the mains

Disconnect the rectifier unit from the power supply and switch OFF the unit. Remove the 24V power supply for the electronics. Take off all connecting leads.

Dismantling the unit

Dismantle the unit as follows:

- ◆ Open the terminals of the DC link bus module.
- ◆ Remove the fixing screws by means of which the unit is fixed to the mounting surface.
- ◆ Pull the unit down until the DC link bus module is completely exposed.
- ◆ Pull the unit out towards you.
- ◆ Lay the unit on its left side.

Opening the unit

- ◆ Unscrew the two fixing screws of the right-hand side wall. The fixing screws are located at the top of the unit at the rear right-hand corner, and at the bottom of the unit in the middle of the right-hand side wall.
- ◆ You do not have to remove the two fixing screws completely, as the wall of the unit is provided with a cutout to enable you to swing out the cover once the screws have been loosened.
- ◆ Open the right-hand side wall. To open it, swing the right-hand side wall towards you and pull it upwards out of the guide on the front edge.

Removing the slot cover

- ◆ Remove the cover of the selected slot on the front panel.
- ◆ To do so, you must carefully cut through the four connecting points of the cover on the front panel with a thin knife.

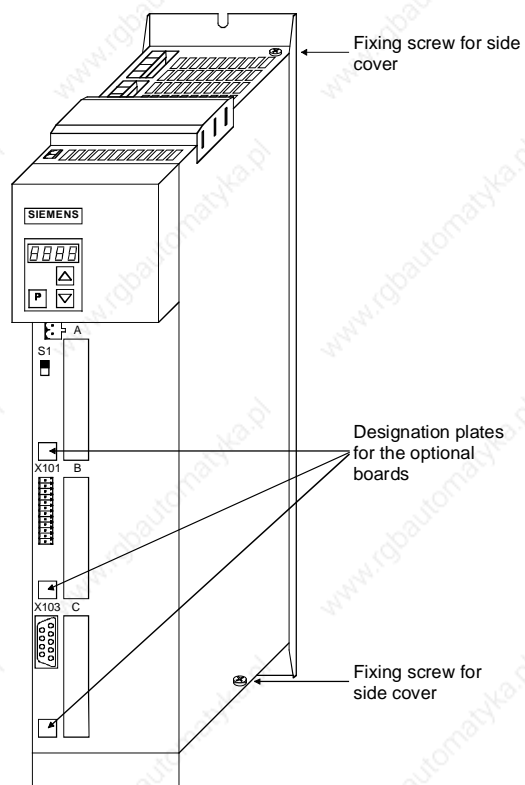

Fig. 5-4 Position of the fixing screws on the right-hand side wall

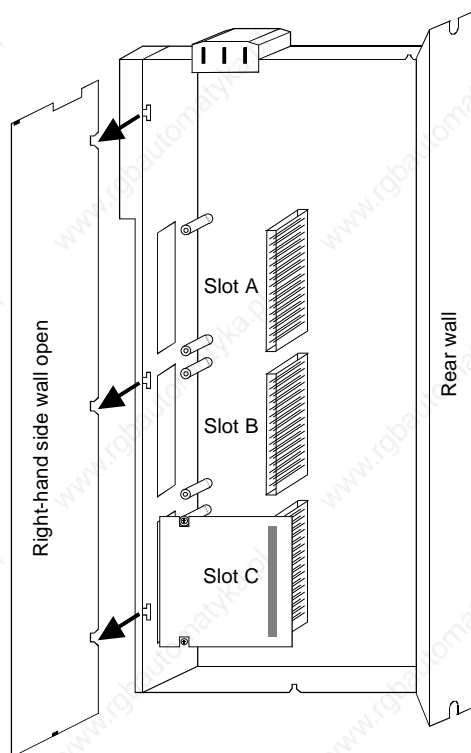

Fig. 5-5 Removing the right-hand side wall

Installing the optional board

Push the optional board from behind into the opening on the front cover (①) until the position of the 64-pole system connector on the main board corresponds with the position of the socket.

Insert the optional board from the right onto the 64-pole system connector on the main board (②). The view shows the installed state.

Screw the optional board tight at the fastening points in the front section of the optional board (③).

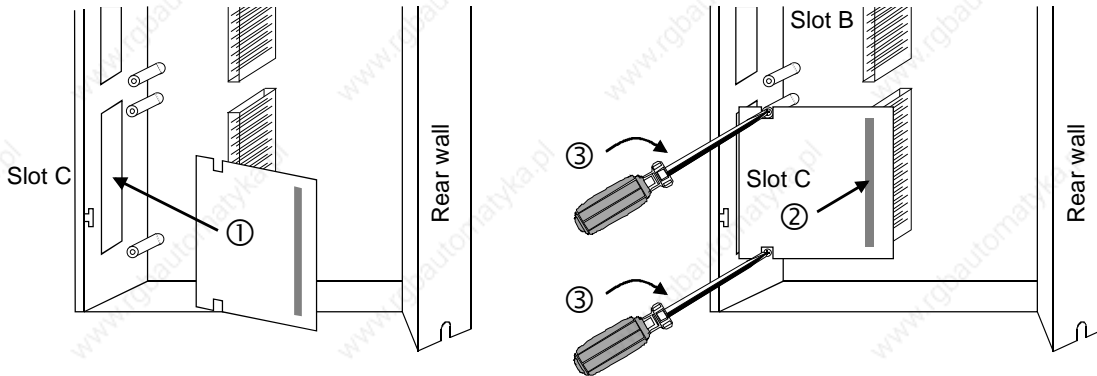

Fig. 5-6 Installing the optional board

Assembling and mounting the unit

Close the right-hand side wall of the unit as follows

- ◆ Insert the right-hand side wall from above into the guide on the front right-hand side.
- ◆ Swing back the side wall.
- ◆ Screw the side wall tight again by means of the two fixing screws.

Mount the unit as follows:

- ◆ Insert the unit into its mounting position from the front underneath the DC link bus module.
- ◆ Lift the unit upwards until the DC link bus module is completely in its original position again.
- ◆ Screw the unit tight to the mounting surface with the fixing screws.
- ◆ Interlock the DC bus module.
- ◆ Re-connect all previously removed connecting cables.
- ◆ Check all connecting cables and the shield to make sure they sit properly and are in the correct position.

Designating the optional board

- ◆ To designate the optional board, insert the relevant designation plate into the envisaged position on the front of the unit.
- ◆ After powering up the voltage, you can log on the optional boards in the software of the unit and commence start-up.

5.2.2 Installing optional boards on units with a width of 135 mm and 180 mm

Disconnecting the rectifier unit from the mains

Disconnect the rectifier unit from the power supply and switch OFF the unit. Remove the 24V power supply for the electronics. Take off all connecting leads.

NOTE

In the case of units with mounting widths of 135 mm and 180 mm, optional boards can be fitted with the power section in place

Opening the unit

- ◆ Loosen the 2 fixing screws on the front of the unit at the top. There is no need to remove the screws completely, since cutouts are provided in the housing to permit the front to come away after the screws have been loosened.
- ◆ Carefully swing the upper front section forwards (approx. 30 °) away from the housing.
- ◆ At the power section, open the locking lever of the ribbon cable that connects up with the control electronics.
- ◆ Take off the front of the unit by moving it forwards.

Removing the slot cover

- ◆ Remove the cover of the selected slot on the front panel.
- ◆ To do so, you must carefully cut through the four connecting points of the cover on the front panel with a thin knife.

Removing the optional board

- ◆ Undo the two optional board screws by about one turn each.
- ◆ Loosen the connection between the system connector and the board so as to prevent any mechanical tension arising when the screws are fully unscrewed.

Mounting the optional board

- ◆ Take out the optional board screws and remove the board.
- ◆ Insert the optional board from the behind the broken-out slot cover (①) until the position of the 64-pole system connector on the electronic board corresponds with the position of the socket.
- ◆ Insert the option board into the 64-pole system connector on the electronic board (②).
- ◆ Screw the optional board tight at the fastening points in the front section of the optional board with the two screws (③).

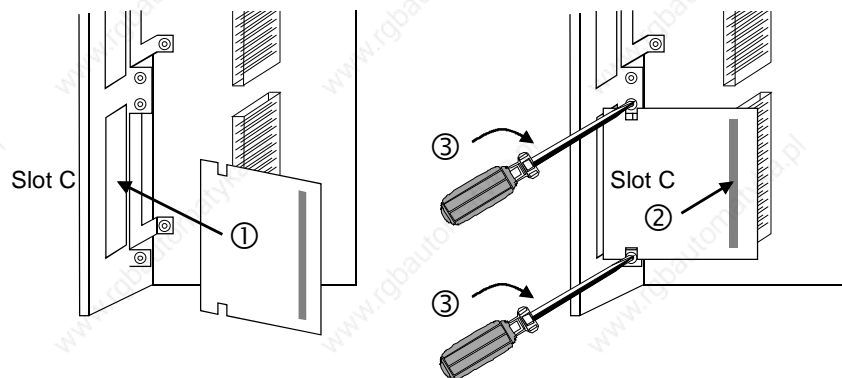

Fig. 5-7 Installing the optional board

Assembling and mounting the unit

- ◆ Keep the front of the unit tilted about approximately 30 ° forwards and insert the cutout of the lower guide plate - approaching from below - into the strip on the power section.
- ◆ Insert the connection cable plug into the power section socket and close the locking lever.
- ◆ Carefully return the front of the unit into the housing. Make sure that the guide plates on the right-hand side of the front (viewed from the front) enter the housing cutouts.
- ◆ Screw the front of the unit securely to the power section with the two fixing screws.

Connecting up the unit

- ◆ Re-connect all previously removed connecting cables.
- ◆ Check all connecting cables and the shield to make sure they sit properly and are in the correct position.

Designating the optional board

- ◆ To designate the optional board, insert the relevant designation plate into the envisaged position on the front of the unit.
- ◆ After powering up the voltage, you can log on the optional boards in the software of the unit and commence start-up.

6 Installation in Conformance with EMC Regulations

The following contains a summary of general information and guidelines which will make it easier for you to comply with EMC and CE regulations.

- ◆ Ensure that there is a conductive connection between the housing of the converters or inverters and the mounting surface. The use of mounting surfaces with good conducting properties (e.g. galvanized steel plate) is recommended. If the mounting surface is insulated (e.g. by paint), use contact washers or serrated washers.
- ◆ All of the metal cabinet parts must be connected through the largest possible surface area and must provide good conductivity. If necessary, use contact washers or serrated washers.
- ◆ Connect the cabinet doors to the cabinet frame using grounding strips which must be kept as short as possible.
- ◆ For the connection between converter/inverter and motor, use shielded cables which have to be grounded on both sides over a large surface area. If the motor terminal box is of plastic, additional grounding strands have to be inserted.
- ◆ The shield of the motor supply cable must be connected to the shield connection of the converter and to the motor mounting panel through the largest possible surface area.
- ◆ The motor cable shield must not be interrupted by output reactors, fuses or contactors.
- ◆ All signal cables must be shielded. Separate the signal cables according to signal groups. Do not route cables with digital signals unshielded next to cables with analog signals. If you use a common signal cable for both, the individual signals must be shielded from each other.
- ◆ Power cables must be routed separately away from signal cables (at least 20 cm apart). Provide partitions between signal cables and power cables. The partitions must be grounded.
- ◆ Connect the reserve cables/conductors to ground at both ends to achieve an additional shielding effect.
- ◆ Lay the cables close to grounded plates as this will reduce the injection of undesired signals.
- ◆ Eliminate any unnecessary cable lengths because these will produce additional coupling capacitances and inductances.

- ◆ Use cables with braided shields. Cables with foil shields have a shielding effect which is worse by a factor of five.
- ◆ Contactor operating coils that are connected to the same supply network as the inverter or that are located in close proximity of the inverter must be connected to overvoltage limiters (e.g. RC circuits, varistors).

You will find further information in the brochure
"Installation Instructions for EMC-correct Installation of Drives"
(Order No.: 6SE7087-6CX87-8CE0).

7 Connecting-up

WARNING



SIMOVERT MASTERDRIVES units are operated at high voltages.

The equipment must be in a no-voltage condition (disconnected from the supply) before any work is carried out!

Only professionally trained, qualified personnel must work on or with the units.

Death, severe bodily injury or significant property damage could occur if these warning instructions are not observed.

Hazardous voltages are still present in the unit up to 5 minutes after it has been powered down due to the DC link capacitors. Thus, the appropriate delay time must be observed before working on the unit or on the DC link terminals.

The power terminals and control terminals can still be live even when the motor is stationary.

If the DC link voltage is supplied centrally, the converters must be reliably isolated from the DC link voltage!

When working on an opened unit, it should be observed that live components (at hazardous voltage levels) can be touched (shock hazard).

The user is responsible that all the units are installed and connected-up according to recognized regulations in that particular country as well as other regionally valid regulations. Cable dimensioning, fusing, grounding, shutdown, isolation and overcurrent protection should be particularly observed.

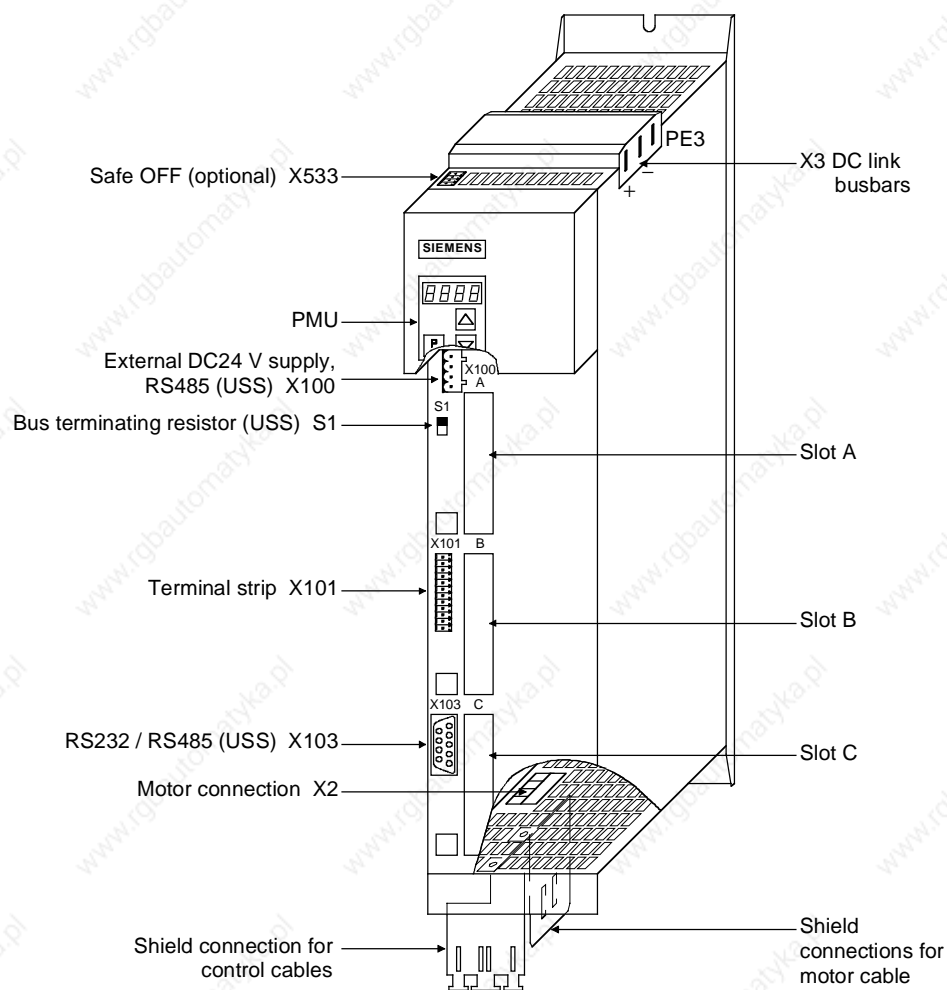

Fig. 7-1 Connection overview of units up to 90 mm wide

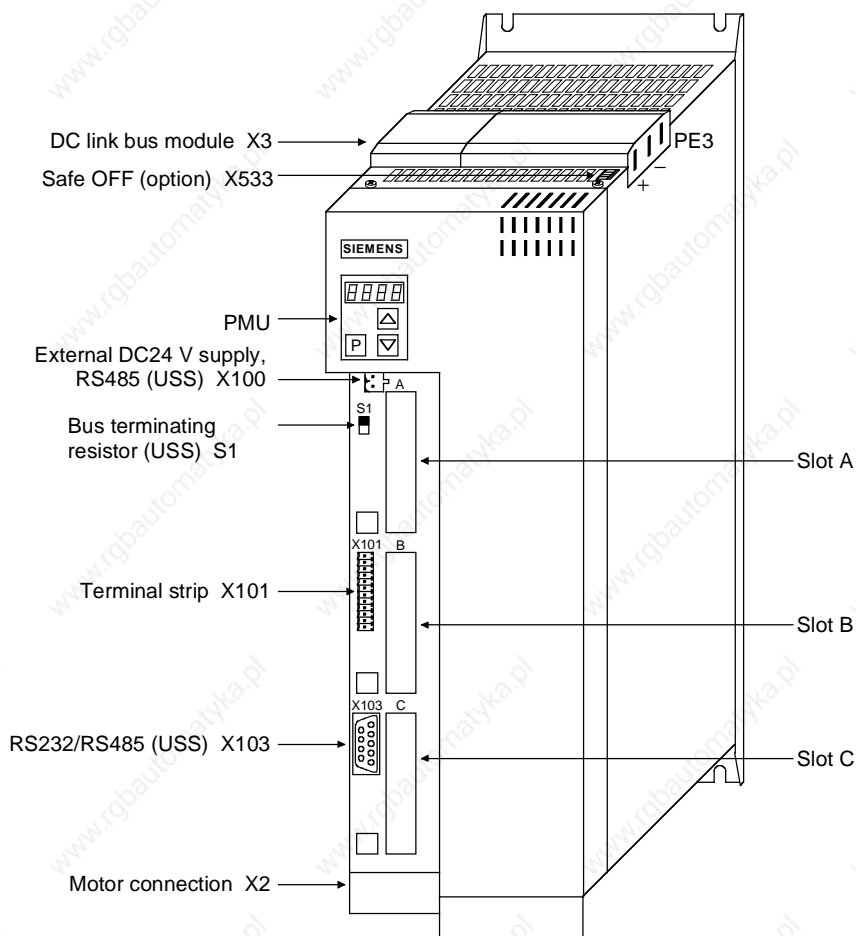

Fig. 7-2 Connection overview of units 135 mm wide

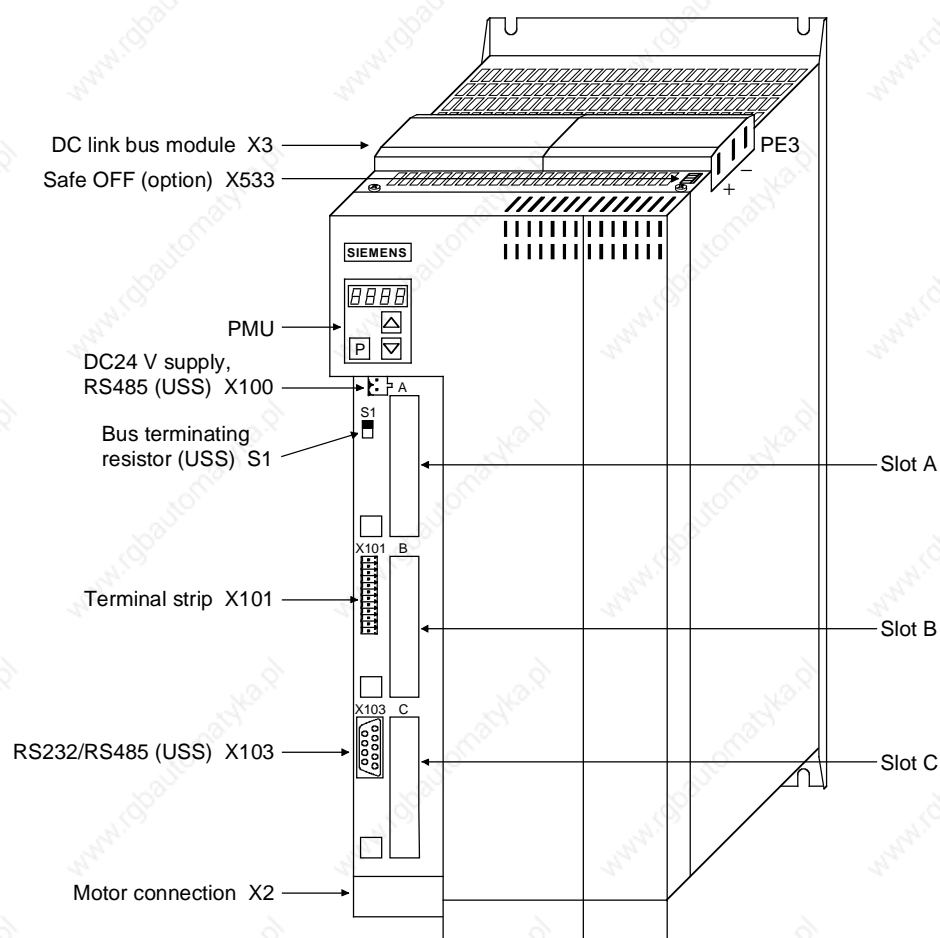

Fig. 7-3 Connection overview of units 180 mm wide

7.1 Power connections

Protective conductor

The protective conductor must be connected up both on the mains side and on the motor side.

On account of leakage currents through the interference-suppression capacitors, a minimum cross-section of 10 mm² must be used in accordance with VDE 0160. If mains connections with cross-sections less than 10 mm² are used, the following measures can be applied.

If the unit is mounted on a grounded mounting surface via a conductive connection, the protective conductor cross-section can be the same as that of the supply-cable conductor.

In the case of insulated installation or a poor conductive connection to the mounting surface, a separate protective conductor with a cross-section of 10 mm² can be connected up instead of the protective conductor of the mains connection.

7.1.1 Power connections for units with a width up to 90 mm

Protective conductor

On top of the unit behind the DC link connection X3 is an extra protective conductor connection in the form of a threaded M4 bolt. It is used for connecting a protective conductor for units in isolated connection.

X3 - DC link bus module

The DC link bus module serves to supply the unit with electrical energy.

Bar	Designation	Meaning	Range
3	PE3	Protective conductor connection	
2	D / L-	DC link voltage -	DC 510 - 650 V
1	C / L+	DC link voltage +	DC 510 - 650 V

Connectable cross-section: "Electro-plated copper" 3x10 mm, rounded off according to DIN 46433

Bar 1 is at the front when installed.

Table 7-1 DC link busbars

X2 – Motor connection

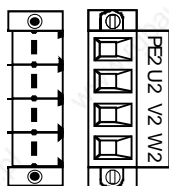

The motor connection is located at the lower section of the unit.

Terminal	Meaning	Range
PE2	Protective conductor connection	
U2	Phase U2 / T1	3 AC 0 V - 480 V
V2	Phase V2 / T2	3 AC 0 V - 480 V
W2	Phase W2 / T3	3 AC 0 V - 480 V

Connectable cross-section: 4 mm² (AWG 10)

Terminal PE2 is at the front when installed.

Table 7-2 Motor connection

The connector must be firmly screwed onto the housing to provide a reliable motor connection.

The motor cables must be dimensioned in accordance with VDE 298, Part 2.

After installation of the connector, the shield of the motor cable must be fixed to the shield plate through a large surface area.

7.1.2 Power connections for units with a width of 135 mm and 180 mm

X3 - DC link bus module

The DC link bus module serves to supply the unit with electrical energy.

Bar	Designation	Meaning	Range
3	PE3	Protective conductor connection	
2	D / L-	DC link voltage -	DC 510 - 650 V
1	C / L+	DC link voltage +	DC 510 - 650 V

Connectable cross-section: "Electro-plated copper" 3x10 mm, rounded off according to DIN 46433

Bar 1 is at the front when installed.

Table 7-3 DC link busbars

X2 – Motor connection

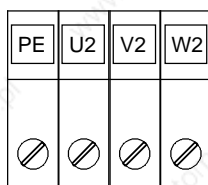

The motor connection is to a terminal block at the bottom of the unit.

Terminal	Meaning	Range
PE	Protective conductor connection	3AC 380 - 480 V
U2 / T1	Phase U2 / T1	3AC 380 - 480 V
V2 / T2	Phase V2 / T2	3AC 380 - 480 V
W2 / T3	Phase W2 / T3	3AC 380 - 480 V

Connectable cross-section:

Housing width 135 mm: 10 mm² (AWG 8)

Housing width 180 mm: 16 mm² (AWG 6)

Viewed from the front, Terminal PE is at the left.

Table 7-4 Motor connection

7.2 Control connections

Standard connections

The basic version of the unit is provided with the following control connections:

- ◆ external 24V supply, USS bus connection (RS485)
- ◆ serial interface for PC or OP1S
- ◆ control terminal strip.

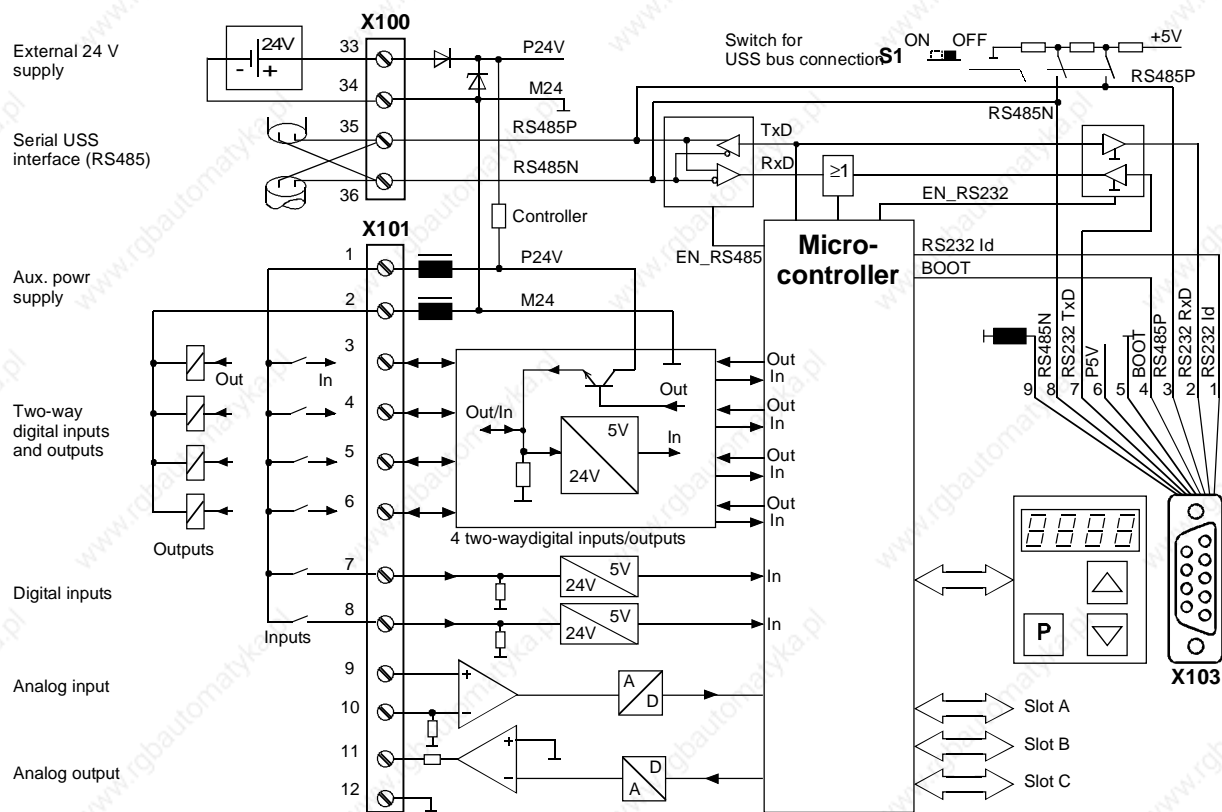

Fig. 7-4 Overview of the standard connections

X100 - external DC24 V supply, USS bus

The 4-pole terminal strip serves to connect the external 24 V DC power supply (supply from the supply unit or an AC/AC converter) and for connecting a USS bus.

The USS bus connection is linked to the control electronics and the 9-pole Sub-D socket of the serial interface X103.

The bus terminating resistor can be switched in via switch S1 as required. The bus termination is switched in when the switch is in the upper position.

The termination has to be switched in whenever the unit is located at one end of the USS bus.

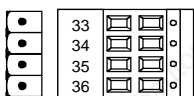

Terminal	Designation	Significance	Range
33	+24 V (in)	24 V DC power supply	DC 24 V
34	0 V	Reference potential	0 V
35	RS485P (USS)	USS bus connection	RS485
36	RS485N (USS)	USS bus connection	RS485

Connectable cross-section: 2.5 mm² (AWG 12)

Terminal 33 is at the top when installed.

Table 7-5 External 24 V supply, USS bus

The unit draws a current of 1 A from the 24 V power supply. When optional boards are plugged in, this increases to a maximum of 1.6 A.

X101 - Control terminal strip

The following connections are provided on the control terminal strip:

- ◆ 4 combined digital inputs and outputs
- ◆ 2 additional digital inputs
- ◆ 1 analog input
- ◆ 1 analog output
- ◆ 24 V auxiliary voltage supply (max. 60 mA) for the inputs.

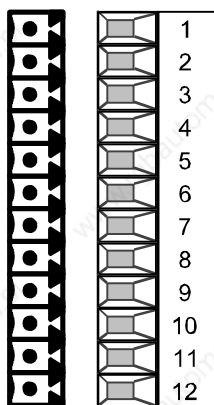

Terminal	Designation	Meaning	Range
1	P24 AUX	Aux. voltage supply	DC 24 V / 60 mA
2	M24 AUX	Reference potential	0 V
3	DIO1	Digital input/output 1	24 V, 10 mA / 20 mA
4	DIO2	Digital input/output 2	24 V, 10 mA / 20 mA
5	DIO3	Digital input/output 3	24 V, 10 mA / 20 mA
6	DIO4	Digital input/output 4	24 V, 10 mA / 20 mA
7	DI5	Digital input 5	24 V, 10 mA
8	DI6	Digital input 6	24 V, 10 mA
9	AI+	Analog input +	11 bit + sign differential input:
10	AI-	Analog input -	$\pm 10 \text{ V} / R_i = 40 \text{ k}\Omega$
11	AO	Analog output	11 bit + sign $\pm 10 \text{ V} / 5 \text{ mA}$
12	M AO	Ground analog output	

Connectable cross-section: 1.5 mm² (AWG 16)

Terminal 1 is at the top when installed.

Table 7-6 Control terminal strip

X103 - Serial interface

It is possible to connect either an OP1S or a PC with RS232 or RS485 serial interface via the 9-pole SUB D socket. There are different connecting cables for the PC for the various transmission protocols.

The 9-pole SUB D socket is internally coupled with the USS bus, thus enabling data exchange with other nodes linked via the USS bus.

This interface is also used for loading software.

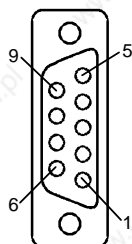

Pin	Designation	Meaning	Range
1	RS232 ID	Changeover to RS232 protocol	Low active
2	RS232 RxD	Receive data via RS232	RS232
3	RS485 P	Data via RS485 interface	RS485
4	Boot	Control signal for software update	Low active
5	M5 AUX	Reference potential to P5V	0 V
6	P5V	5 V aux. voltage supply	+5 V, max. 200 mA
7	RS232 TxD	Transmit data via RS232	RS232
8	RS485 N	Data via RS485 interface	RS485
9	M_RS232/485	Digital ground (choked)	

Table 7-7 Serial interface

X533 - Safe OFF Option

With the safe OFF option, the power supply for pulse transmission in the power section can be interrupted by means of a safety relay. This ensures that the unit cannot produce a rotating field when it is located at a connected-up motor.

Even if the control electronics give start signals, the active part of the motor cannot move.

This allows mechanical work on the motor or on coupled machine parts to be performed with the power supply ON and without the motor being electrically isolated from the unit.

WARNINGS



- ◆ The safe OFF option does not provide any electrical isolation between the motor terminals and the power section!
- ◆ When in the "safe OFF" condition, the motor terminals are live with hazardous voltage!

NOTE

The safe OFF option is not suitable for bringing a running motor to a quick stop, because the control signals are switched OFF and the motor is therefore braked by the coupled load only.

The safe OFF option consists of the safety relay and the terminals for the relay control with a checkback signal contact.

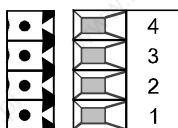

Terminal	Designation	Significance	Range
4	P24	24 V DC	DC 24 V
3	K1. a	Control terminal	
2	K1. 12	NC contact	$I_{max} = 1 \text{ A}$
1	K1. 11	NC contact	24 V

Connectable cross-section: 1.5 mm² (AWG 16)

Terminal 1 is at the front when installed in units with housings up to 90 mm wide, and at the rear when installed in units with housings more than 90 mm wide.

Table 7-8 Terminal assignment for the "Safe OFF" option

8 Parameterization

The functions stored in the units are adapted to your specific application by means of parameters. Every parameter is clearly identified by its parameter name and its parameter number. In addition to the parameter name and number, many parameters also have a parameter index. These indices enable several values to be stored for a parameter under one parameter number.

Parameter numbers consist of a letter and a three-digit number. The upper-case letters P, U, H and L represent the parameters which can be changed, and the lower-case letters r, n, d and c represent the visualization parameters which cannot be changed.

Examples

DC Bus Volts r006 = 541	Parameter name:	DC Bus volts
	Parameter number:	r006
	Parameter index:	Does not exist
	Parameter value:	541 V
Src ON/OFF1 P554.2 = 20	Parameter name:	Src ON/OFF1
	Parameter number:	P554
	Parameter index:	2
	Parameter value:	20

Parameters can be input as follows:

- ◆ Via the PMU parameterizing unit which is permanently mounted on the front of the units,
- ◆ Via the user-friendly optional OP1S operator control panel or
- ◆ Via a PC and the SIMOVIS service program.

The parameters stored in the units can only be changed under certain conditions. The following preconditions must be satisfied before they can be changed.

- ◆ The parameter must be a changeable parameter. (Designated by upper-case letters in the parameter number).
- ◆ Parameter access must be granted. (P053 = 6 for parameterizing via the PMU or the OP1S).
- ◆ The unit must be in a status which permits parameters to be changed. (Carry out initial parameterization only in powered-down status).
- ◆ The lock and key mechanism must not be activated (Deactivation by parameter reset to factory setting).

8.1 Parameter input via the PMU

The PMU parameterizing unit enables parameterization, operator control and visualization of the converters and inverters directly on the unit itself. It is an integral part of the basic units. It has a four-digit seven-segment display and several keys.

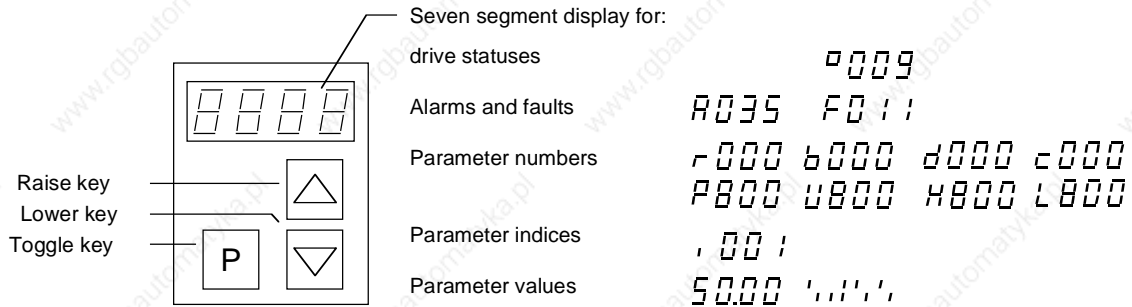

Fig. 8-1 PMU parameterizing unit

Key	Significance	Function
	Toggle key	<ul style="list-style-type: none"> For switching between parameter number, parameter index and parameter value in the sequence indicated (command becomes effective when the key is released). If fault display is active: Acknowledge the fault
	Raise key	For increasing the displayed value: <ul style="list-style-type: none"> Short press = single-step increase Long press = rapid increase
	Lower key	For lowering the displayed value: <ul style="list-style-type: none"> Short press = single-step decrease Long press = rapid decrease
	Hold toggle key and press raise key	<ul style="list-style-type: none"> If parameter number level is active: For jumping back and forth between the last selected parameter number and the operating display (r000) If fault display is active: For switching over to parameter number level If parameter value level is active: For shifting the displayed value one digit to the right if parameter value cannot be displayed with 4 figures (left-hand figure flashes if there are any further invisible figures to the left)
	Hold toggle key and press lower key	<ul style="list-style-type: none"> If parameter number level is active: For jumping directly to the operating display (r000) If parameter value level is active: For shifting the displayed value one digit to the left if parameter value cannot be displayed with 4 figures (right-hand figure flashes if there are any further invisible figures to the right)

Table 8-1 Operator control elements on the PMU

Toggle key (P key)

As the PMU only has a four-digit seven-segment display, the 3 descriptive elements of a parameter

- ◆ Parameter number,
- ◆ Parameter index (if the parameter is indexed) and
- ◆ Parameter value

cannot be displayed at the same time. For this reason, you have to switch between the individual descriptive elements by depressing the toggle key. After the desired level has been selected, adjustment can be made using the raise key or the lower key.

With the toggle key, you can change over:

- from the parameter number to the parameter index
- from the parameter index to the parameter value
- from the parameter value to the parameter number

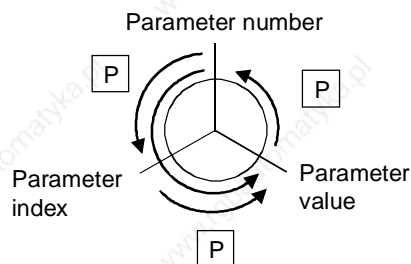

If the parameter is not indexed, you can jump directly from the parameter number to the parameter value.

NOTE

If you change the value of a parameter, this change generally becomes effective immediately. It is only in the case of acknowledgement parameters (marked in the parameter list by an asterisk ' * ') that the change does not become effective until you change over from the parameter value to the parameter number.

Parameter changes made using the PMU are always safely stored in the EEPROM (protected in case of power failure) once the toggle key has been depressed.

Example

The following example shows the individual operator control steps to be carried out on the PMU for a parameter reset to factory setting.

Set P053 to 0002 and grant parameter access via PMU

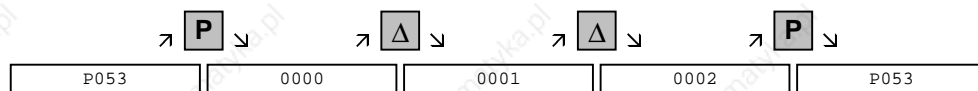

Select P060

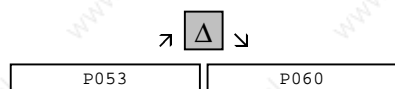

Set P060 to 0002 and select "Fixed settings" menu

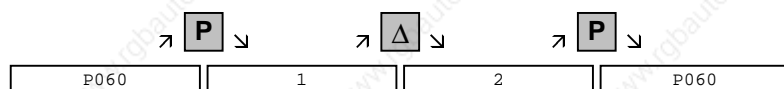

Select P970

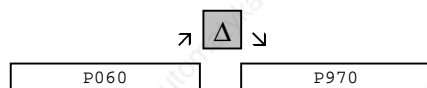

Set P970 to 0000 and start parameter reset

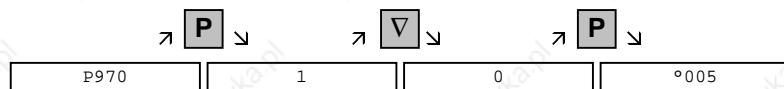

8.2 Parameter input via the OP1S

The operator control panel (OP1S) is an optional input/output device which can be used for parameterizing and starting up the units. Plain-text displays greatly facilitate parameterization.

The OP1S has a non-volatile memory and can permanently store complete sets of parameters. It can therefore be used for archiving sets of parameters. The parameter sets must be read out (upread) from the units first. Stored parameter sets can also be transferred (downloaded) to other units.

The OP1S and the unit to be operated communicate with each other via a serial interface (RS485) using the USS protocol. During communication, the OP1S assumes the function of the master whereas the connected units function as slaves.

The OP1S can be operated at baud rates of 9.6 kBd and 19.2 kBd, and is capable of communicating with up to 32 slaves (addresses 0 to 31). It can therefore be used both in a point-to-point link (e.g. during initial parameterization) and within a bus configuration.

The plain-text displays can be shown in one of five different languages (German, English, Spanish, French, Italian). The language is chosen by selecting the relevant parameter for the slave in question.

Order numbers

Components	Order Number
OP1S	6SE7090-0XX84-2FK0
Connecting cable 3 m	6SX7010-0AB03
Connecting cable 5 m	6SX7010-0AB05
Adapter for installation in cabinet door incl. 5 m cable	6SX7010-0AA00

NOTE

The parameter settings for the units connected to the OP1S are given in the corresponding documentation of the unit (Compendium).

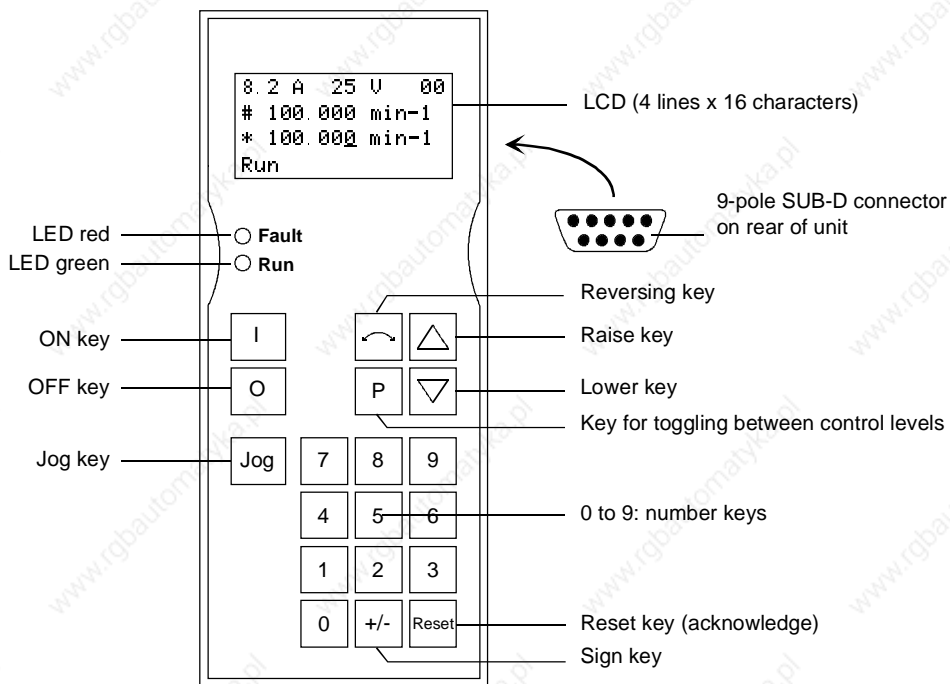

Fig. 8-2 View of the OP1S

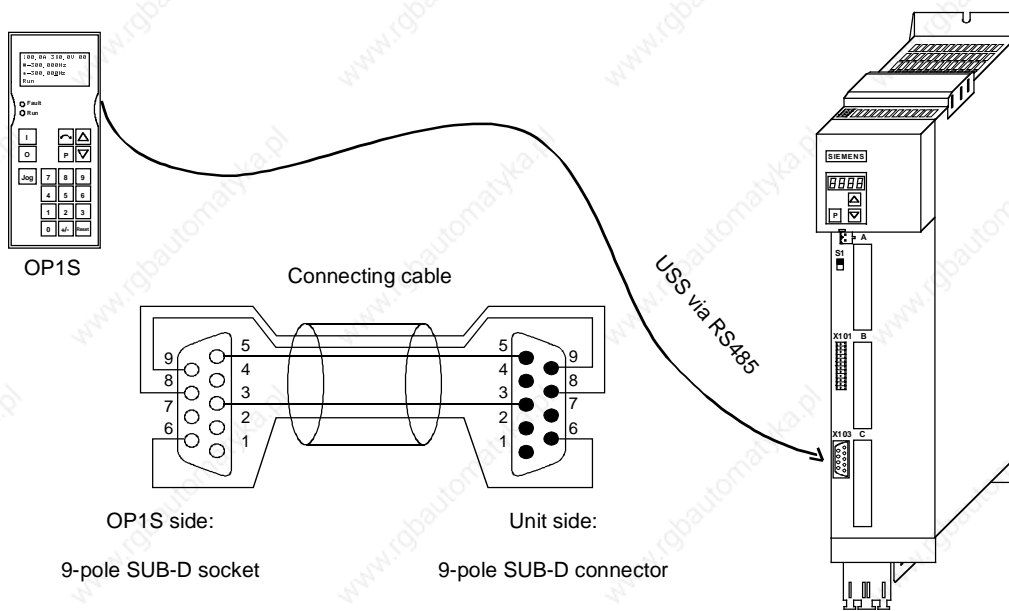

Fig. 8-3 Example: The OP1S in a point-to-point link with the Compact PLUS unit

NOTE

In the as-delivered state or after a reset of the parameters to the factory setting, a point-to-point link can be adopted with the OP1S without any further preparatory measures and parameterization can be commenced.









Key	Significance	Function
	ON key	<ul style="list-style-type: none"> For energizing the drive (enabling motor activation). The function must be enabled by means of parameterization.
	OFF key	<ul style="list-style-type: none"> For de-energizing the drive by means of OFF1, OFF2 or OFF3, depending on parameterization. This function must be enabled by means of parameterization.
	Jog key	<ul style="list-style-type: none"> For jogging with jogging setpoint 1 (only effective when the unit is in the "ready to start" state). This function must be enabled by means of parameterization.
	Reversing key	<ul style="list-style-type: none"> For reversing the direction of rotation of the drive. The function must be enabled by means of parameterization.
	Toggle key	<ul style="list-style-type: none"> For selecting menu levels and switching between parameter number, parameter index and parameter value in the sequence indicated. The current level is displayed by the position of the cursor on the LCD display (the command comes into effect when the key is released). For conducting a numerical input
	Reset key	<ul style="list-style-type: none"> For leaving menu levels If fault display is active, this is for acknowledging the fault. This function must be enabled by means of parameterization.
	Raise key	<p>For increasing the displayed value:</p> <ul style="list-style-type: none"> Short press = single-step increase Long press = rapid increase If motorized potentiometer is active, this is for raising the setpoint. This function must be enabled by means of parameterization
	Lower key	<p>For lowering the displayed value:</p> <ul style="list-style-type: none"> Short press = single-step decrease Long press = rapid decrease If motorized potentiometer is active, this is for lowering the setpoint. This function must be enabled by means of parameterization.
	Sign key	<ul style="list-style-type: none"> For changing the sign so that negative values can be entered
	Number keys	<ul style="list-style-type: none"> Numerical input

Table 8-2 Operator control elements of the OP1S

NOTE

If you change the value of a parameter, the change does not become effective until the toggle key (P) is pressed.

Parameter changes made using the OP1S are always stored safely in the EEPROM (protected in case of power failure) once the toggle key (P) has been pressed.

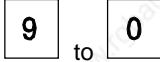
Some parameters may also be displayed without a parameter number, e.g. during quick parameterization or if "Fixed setting" is selected. In this case, parameterization is carried out via various sub-menus.

Example of how to proceed for a parameter reset.

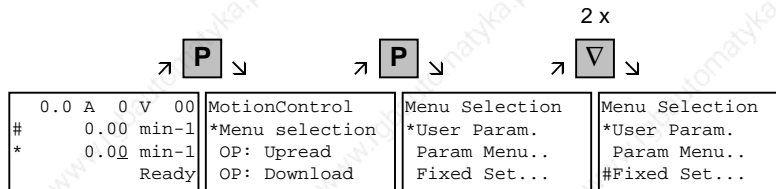

Selection of fixed setting

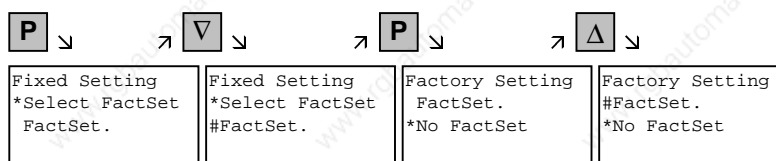

Selection of factory setting

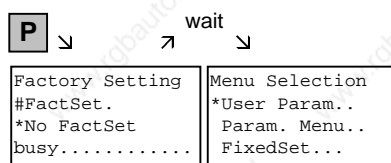

Start of factory setting

NOTE

It is not possible to start the parameter reset in the "Run" status.

8.3 Parameter reset to factory setting

The factory setting is the defined initial state of all parameters of a unit. The units are delivered with this setting.

You can restore this initial state at any time by resetting the parameters to the factory setting, thus canceling all parameter changes made since the unit was delivered.

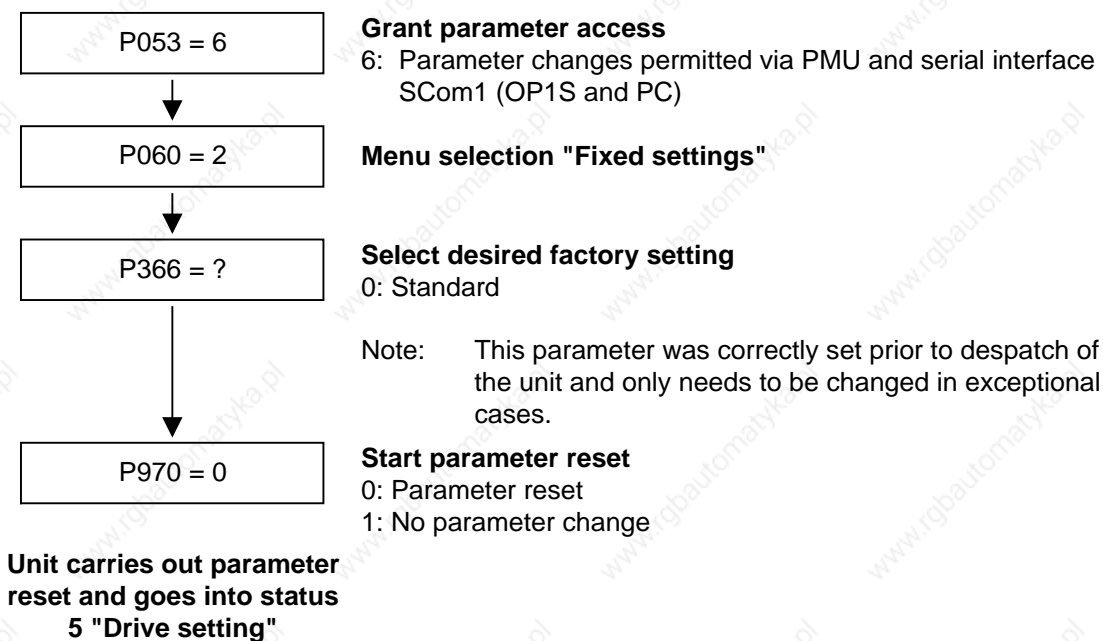

Fig. 8-4 Sequence for parameter reset to factory setting

8.4 Parameterizing by download

Downloading with OP1S

The OP1S operator control panel is capable of upreading parameter sets from the units and storing them. These parameter sets can then be transferred to other units by download. Downloading with the OP1S is thus the preferred method of parameterizing replacement units in a service case.

During downloading with the OP1S, it is assumed that the units are in the as-delivered state. The parameters for the power section definition are thus not transferred (see section "Detailed parameterization, power section definition"). If a PIN has been entered to release optional technology functions, this is also not overwritten during downloading.

With the "OP: Download" function, a parameter set stored in the OP1S can be written into the connected slave. Starting from the basic menu, the "OP: Download" function is selected with "Lower" or "Raise" and activated with "P".

↗ P ↘	
MotionControl	Download
*Menu selection	*1909199701
OP: Upread	MASTERDRIVES MC
#OP: Download	PLUS

Example: Selecting and activating the "Download" function

Now one of the parameter sets stored in the OP1S has to be selected using the "Lower" or "Raise" keys (displayed in the second line). The selected ID is confirmed with the "P" key. Now the slave ID can be displayed with "Lower" or "Raise". The slave ID contains various characteristic features of the unit such as rated output, order number, software version, etc.

The "Download" procedure is then started with the "P" key. During download, the OP1S displays the parameter currently being written.

↗ P ↘		
Download	Download	MotionControl 00
*1909199701	*1909199701	Download
MASTERDRIVES MC	MASTERDRIVES MC	Pxxx
PLUS	PLUS	

Example: Confirming the ID and starting the "Download" procedure

With "Reset", the procedure can be stopped at any time. If downloading has been fully completed, the message "Download ok" appears and the display returns to the basic menu.

After the data set to be downloaded has been selected, if the identification of the stored data set does not agree with the identification of the connected unit, an error message appears for approximately 2 seconds. The operator is then asked if downloading is to be discontinued.

↗ P ↘	↗ P ↘	↗ 2 s ↘	
Download *1909199701 MASTERDRIVES MC PLUS	Download *1909199701 MASTERDRIVES MC PLUS	Error: Different IDs	MotionControl 00 Stop download? #yes no

Yes: Downloading is discontinued.

No: Downloading is carried out.

8.5 Parameterizing with parameter modules

Pre-defined, function-assigned parameter modules are stored in the units. These parameter modules can be combined with each other, thus making it possible to adjust your unit to the desired application by just a few parameter steps. Detailed knowledge of the complete parameter set of the unit is not required.

Parameter modules are available for the following function groups:

1. Motors
2. Motor encoders
3. Control types
4. Setpoint and command sources

Parameterization is effected by selecting a parameter module from each function group and then starting quick parameterization. Depending on your selection, the necessary unit parameters are set to produce the desired control functionality. The parameters necessary for fine adjustment of the control structure are automatically adopted in the user menu.

NOTE

If parameter changes have already been carried out on the unit, it is recommended that you carry out a parameter reset to the factory setting prior to performing "Quick parameterization".

P060 = 3

Select "Quick parameterization" menu

P071 = ?

Enter the unit supply voltage in V
(direct voltage for DC supply,
rms value of AC voltage for AC supply)

P095 = ?

Select type of motor
0: No motor connected
1: Synchronous servomotor ROTEC 1FT6/1FK6
2: Induction servomotor ROTEC 1PA6/1PL6

P096 = ?

Enter the code number for the connected 1FK6/1FT6 motor (for list see attachment)

P097 = ?

Enter the code number for the connected 1PA6/1PL6 motor (for list see attachment)

P115 = 1

Start calculation of motor model

P130 = ?

Select motor encoder
0: Without encoder
1: 2-pole resolver
2: Resolver with pole pair number of motor
3: Encoder 2048/rev.
4: Multiturn encoder 2048/rev.
5: Pulse encoder 1024/rev.

P367 = ?

Select type of control for quick parameterization
0: V/f open-loop control
2: Torque closed-loop control
3: Speed closed-loop control

P368 = ?

Select setpoint and command source
0: - not used -
1: Analog and digital inputs on the terminal strip
2: Fixed setpoints and digital inputs on the terminal strip
3: MOP and digital inputs on the terminal strip
4: USS1 (e.g. with SIMATIC)
5: SIMOLINK (SLB) (without fig.)
6: PROFIBUS (CBP) (without fig.)
7: OP1S and fixed setpoints via SCom1 (X300: PMU)

P368 = 0,1,2,3 4,7 5 6

Enter the USS bus address

P700.01 = ?

Enter the SIMOLINK module address

P740 = ?

Enter the PROFIBUS address

P918.01 = ?

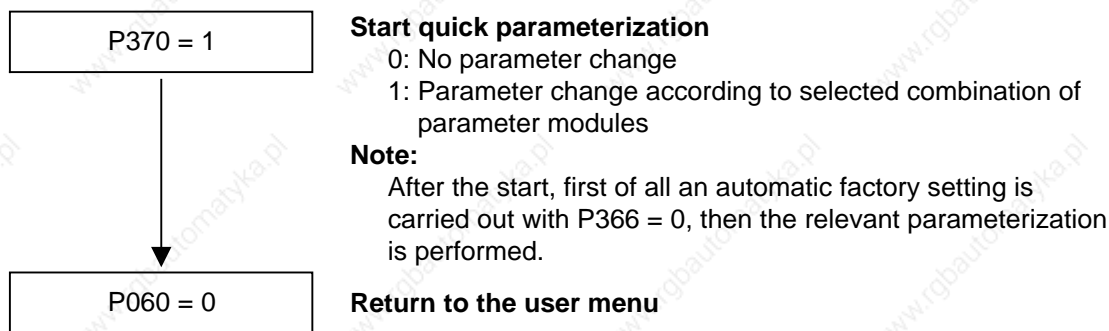

Fig. 8-5 Sequence for parameterizing with parameter modules

Function diagram modules

Function diagram modules (function diagrams) are shown after the flow chart for parameter modules stored in the unit software. On the first few pages are the:

- ◆ setpoint and command sources, on the following pages are the
- ◆ analog outputs and the display parameters and the
- ◆ open-loop and closed-loop control types.

It is therefore possible to put together the function diagrams to exactly suit the selected combination of setpoint/command source and open/closed-loop control type. This will give you an overview of the functionality parameterized in the units and of the necessary assignment of the terminals.

The function parameters and visualization parameters specified in the function diagrams are automatically adopted in the user menu and can be visualized or changed there.

The parameter numbers of the user menu are entered in P360.

Setpoint and command source
Terminal strip and analog input

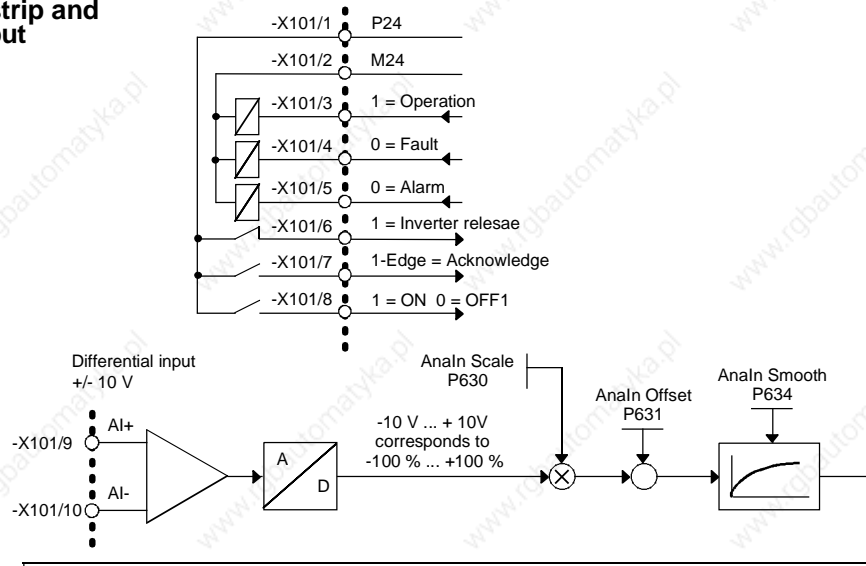

Control type:
Speed control

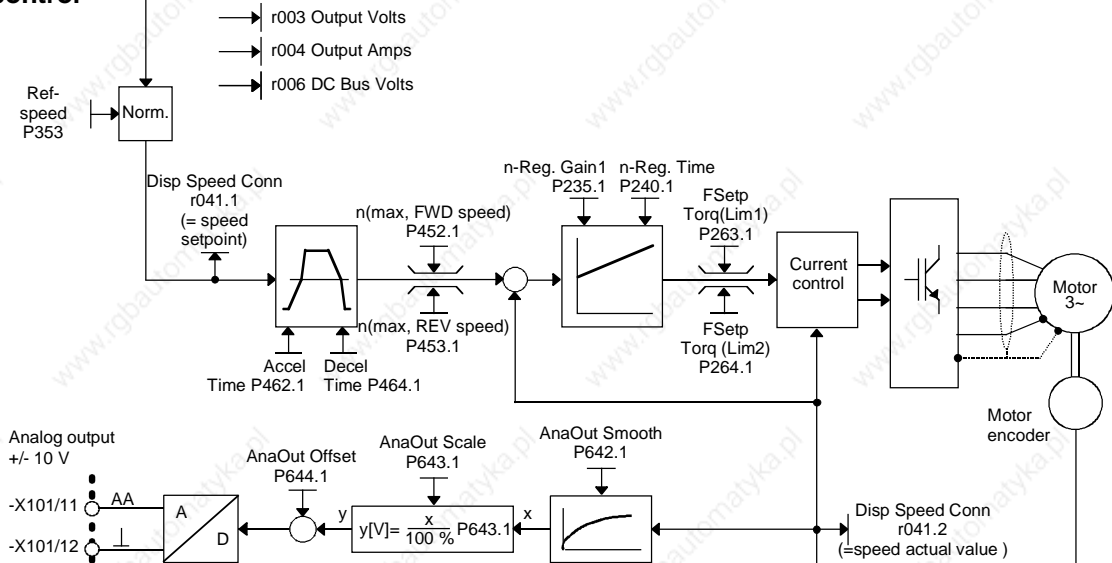

Type of encoder:
Resolver

Data of resolver to be connected:
- 2-pole

Data of pulse encoder simulation:
- 1024 pulses/revolution

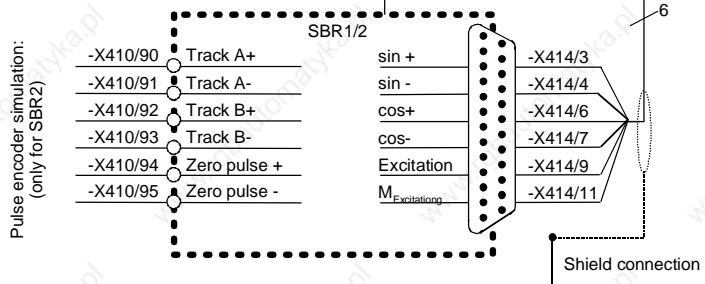

Setpoint and command source:

Terminal strip and fixed setpoints (FSetp)

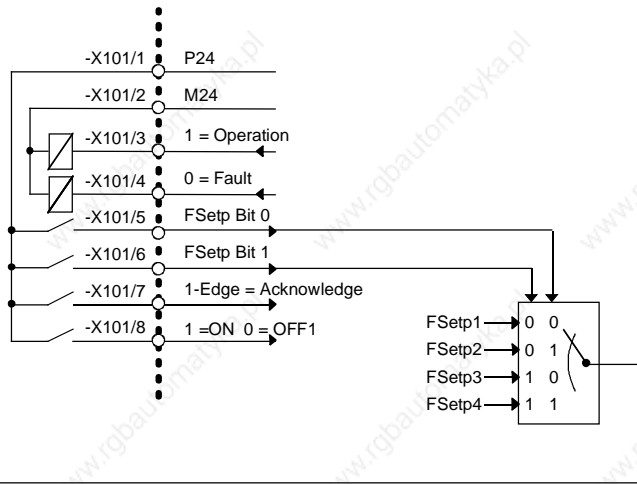

Control type:
Torque control

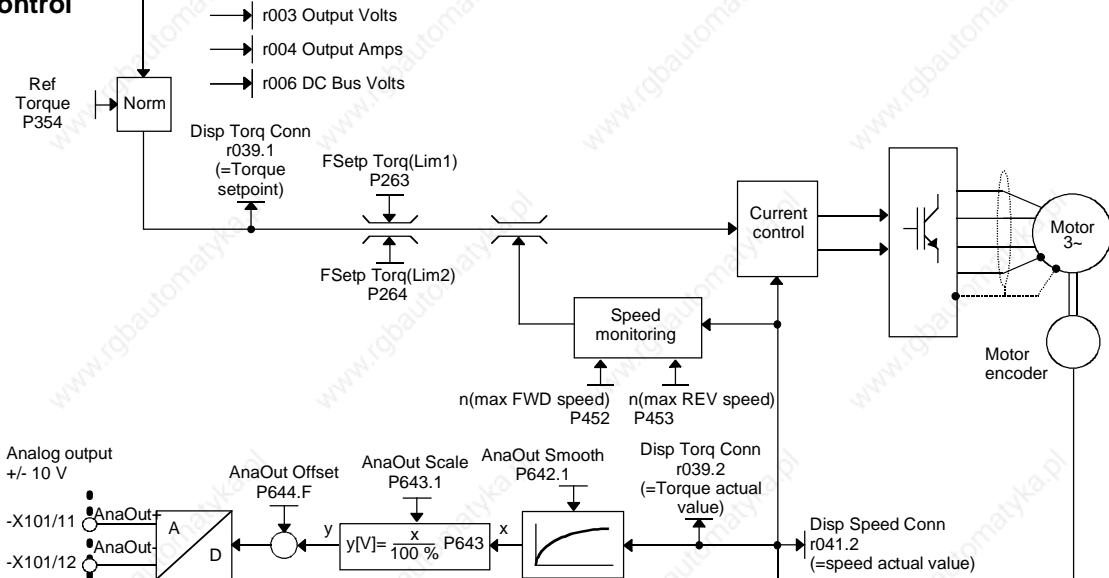

Analog output
+/- 10 V

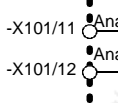

Type of encoder:
Pulse encoder

Data of pulse encoder to be connected:
 - HTL encoder (15 V)
 - 1024 Inc.
 - without control track

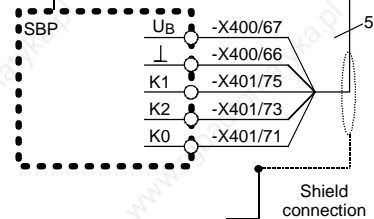

Setpoint and command source

Terminal strip and motorized potentiometer

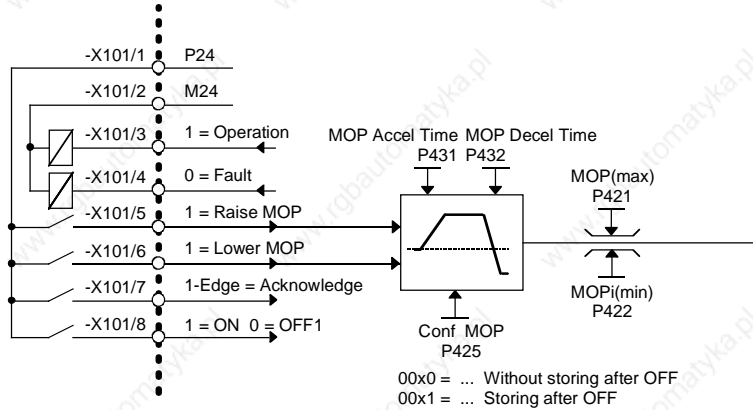

Type of control
V/f control

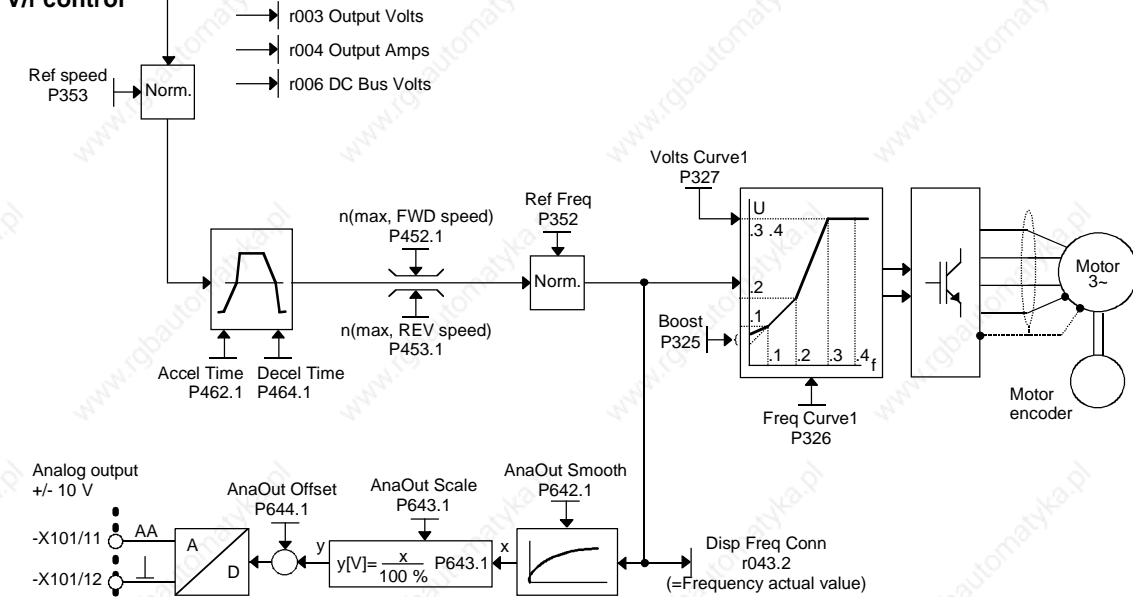

Type of encoder:
Without encoder

Setpoint and command source
USS

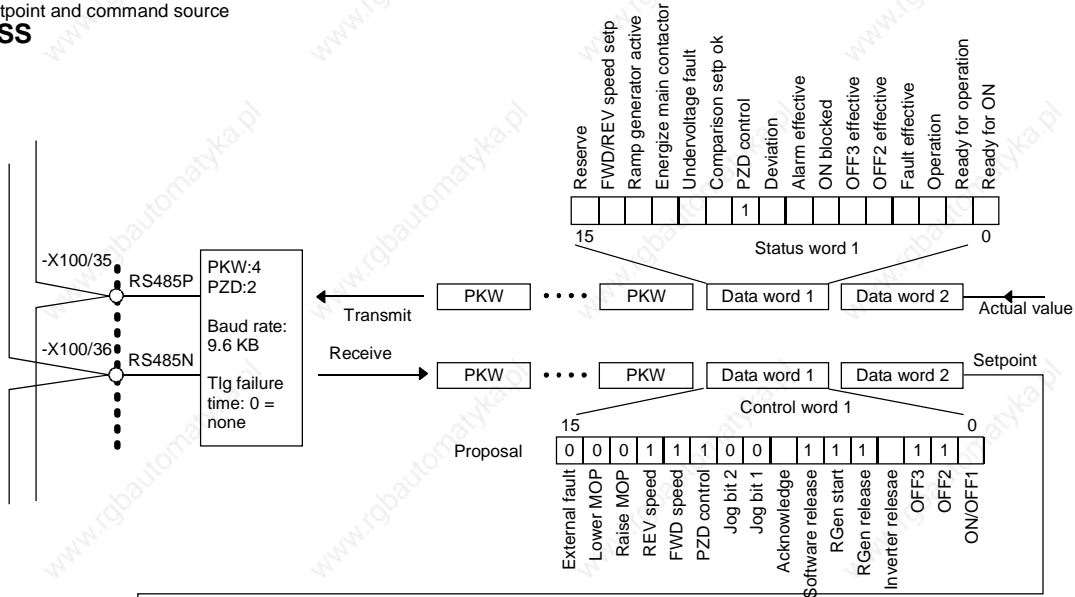

**Motor list
1FK6 / 1FT6**

Input in P096	Motor order-number (MLFB)	Speed n_n [1/min]	Torque T_n [Nm]	Current I_n [A]
1	1FK6032-6AK7	6000	0,8	1.5
2	1FK6040-6AK7	6000	0.8	1.8
3	1FK6042-6AF7	3000	2.6	2.4
4	1FK6060-6AF7	3000	4.0	3.1
5	1FK6063-6AF7	3000	6.0	4.9
6	1FK6080-6AF7	3000	6.8	5.3
7	1FK6083-6AF7	3000	10.5	7.8
8	1FK6100-8AF7	3000	12.0	9.0
9	1FK6101-8AF7	3000	15.5	10.8
10	1FK6103-8AF7	3000	16.5	11.6
11	1FT6031-4AK7_	6000	0.75	1.2
12	1FT6034-1AK7_-3A 1FT6034-4AK7_	6000	1.4	2.1
13	1FT6041-4AF7_	3000	2.15	1.7
14	1FT6041-4AK7_	6000	1.7	2,4
15	1FT6044-1AF7_-3A 1FT6044-4AF7_	3000	4.3	2.9
16	1FT6044-4AK7_	6000	3.0	4.1
17	1FT6061-6AC7_	2000	3.7	1.9
18	1FT6061-1AF7_-3A 1FT6061-6AF7_	3000	3.5	2.6
19	1FT6061-6AH7_	4500	2.9	3.4
20	1FT6061-6AK7_	6000	2.1	3.1
21	1FT6062-6AC7_	2000	5.2	2.6
22	1FT6062-1AF7_-3A 1FT6062-6AF7_	3000	4.6	3.4
23	1FT6062-6AH7_	4500	3.6	3.9
24	1FT6062-6AK7_	6000	2.1	3.2
25	1FT6064-6AC7_	2000	8.0	3.8
26	1FT6064-1AF7_-3A 1FT6064-6AF7_	3000	7.0	4.9
27	1FT6064-6AH7_	4500	4.8	5.5
28	1FT6064-6AK7_	6000	2.1	3.5
29	1FT6081-8AC7_	2000	7.5	4.1
30	1FT6081-8AF7_	3000	6.9	5.6
31	1FT6081-8AH7_	4500	5.8	7.3
32	1FT6081-8AK7_	6000	4.6	7.7
33	1FT6082-8AC7_	2000	11.4	6.6
34	1FT6082-1AF7_-1A 1FT6082-8AF7_	3000	10.3	8.7

Input in P096	Motor order-number (MLFB)	Speed n_n [1/min]	Torque T_n [Nm]	Current I_n [A]
35	1FT6082-8AH7_	4500	8.5	11.0
36	1FT6082-8AK7_	6000	5.5	9.1
37	1FT6084-8AC7_	2000	16.9	8.3
38	1FT6084-1AF7_-1A 1FT6084-8AF7_	3000	14.7	11.0
39	1FT6084-8AH7_	4500	10.5	12.5
40	1FT6084-8AK7_	6000	6.5	9.2
41	1FT6084-8SC7_	2000	23.5	12.5
42	1FT6084-8SF7_	3000	22.0	17.0
43	1FT6084-8SH7_	4500	20.0	24.5
44	1FT6084-8SK7_	6000	17.0	25.5
45	1FT6086-8AC7_	2000	23.0	10.9
46	1FT6086-1AF7_-1A 1FT6086-8AF7_	3000	18.5	13.0
47	1FT6086-8AH7_	4500	12.0	12.6
48	1FT6086-8SC7_	2000	33.0	17.5
49	1FT6086-8SF7_	3000	31.0	24.5
50	1FT6086-8SH7_	4500	27.0	31.5
51	1FT6086-8SK7_	6000	22.0	29.0
52	1FT6102-8AB7_	1500	24.5	8.4
53	1FT6102-1AC7_-1A 1FT6102-8AC7_	2000	23.0	11.0
54	1FT6102-8AF7_	3000	19.5	13.2
55	1FT6102-8AH7_	4500	12.0	12.0
56	1FT6105-8AB7_	1500	42.0	14.5
57	1FT6105-1AC7_-1A 1FT6105-8AC7_	2000	38.0	17.6
58	1FT6105-8AF7_	3000	31.0	22.5
59	1FT6105-8SB7_	1500	57.0	21.5
60	1FT6105-8SC7_	2000	55.0	28.0
61	1FT6105-8SF7_	3000	49.0	35.0
62	1FT6108-8AB7_	1500	61.0	20.5
63	1FT6108-8AC7_	2000	55.0	24.5
64	1FT6108-8SB7_	1500	83.0	31.0
65	1FT6108-8SC7_	2000	80.0	39.0
66	1FT6132-6AB7_	1500	62.0	19.0
67	1FT6132-6AC7_	2000	55.0	23.0
68	1FT6132-6AF7_	3000	36.0	23.0
69	1FT6132-6SB7_	1500	100.0	36.0

Input in P096	Motor order-number (MLFB)	Speed n_n [1/min]	Torque T_n [Nm]	Current I_n [A]
70	1FT6132-6SC7_	2000	98.0	46.0
71	1FT6132-6SF7_	3000	90.0	62.0
72	1FT6134-6AB7_	1500	75.0	24.0
73	1FT6134-6AC7_	2000	65.0	27.0
74	1FT6134-6SB7_	1500	130.0	45.0
75	1FT6134-6SC7_	2000	125.0	57.0
76	1FT6134-6SF7_	3000	110.0	72.0
77	1FT6136-6AB7_	1500	88.0	27.0
78	1FT6136-6AC7_	2000	74.0	30.0
79	1FT6136-6SB7_	1500	160.0	55.0
80	1FT6136-6SC7_	2000	150.0	72.0
81	1FT6108-8SF7_	3000	70.0	53.0

Table 8-3 Motor list 1FK6 / 1FT6

**Motor list
1PA6 / 1PL6**

Input in P097	Motor order number (MLFB)	Speed n_n [1/min]	Torque T_n [Nm]	Current I_n [A]
1	1PA6101-4_F	1750	24	9.0
2	1PA6103-4_D	1150	36	9.6
3	1PA6103-4_F	1750	34	12.7
4	1PA6103-4_G	2300	31	15.4
5	1PA6105-4_F	1750	44	16.2
6	1PA6107-4_D	1150	60	16.0
7	1PA6107-4_F	1750	57	20.1
8	1PA6131-4_F	1750	71	23.7
9	1PA6133-4_D	1150	112	27.5
10	1PA6133-4_F	1750	96	33.1
11	1PA6133-4_G	2300	93	42.3
12	1PA6135-4_F	1750	117	40.0
13	1PA6137-4_D	1150	162	40.6
14	1PA6137-4_F	1750	136	53.0
15	1PA6137-4_G	2300	127	53.9
16	1PA6163-4_B	400	227	28.2
17	1PA6163-4_D	1150	208	52.1
18	1PA6163-4_F	1750	185	69.0
19	1PA6163-4_G	2300	158	78.5
20	1PA6163-4_B	400	310	35.6
21	1PA6167-4_D	1150	257	66.4
22	1PA6167-4_F	1750	224	75.2
23	1PA6184-4_B	400	390	51.0
24	1PA6184-4_D	1150	366	89.0
25	1PA6184-4_F	1750	325	122.0
26	1PA6184-4_L	2900	265	158.0
27	1PA6186-4_B	400	506	68.0
28	1PA6186-4_D	1150	485	116.0
29	1PA6186-4_F	1750	465	168.0
30	1PA6186-4_L	2900	333	205.0
31	1PA6224-4_B	400	725	89.0
32	1PA6224-4_D	1150	670	162.0
33	1PA6224-4_F	1750	605	205.0
34	1PA6224-4_L	2900	490	275.0
35	1PA6226-4_B	400	935	116.0
36	1PA6226-4_D	1150	870	200.0
37	1PA6226-4_F	1750	737	255.0
38	1PA6226-4_L	2900	610	35.0

Input in P097	Motor order number (MLFB)	Speed n_n [1/min]	Torque T_n [Nm]	Current I_n [A]
39	1PA6228-4_B	400	1145	13.8
40	1PA6228-4_D	1150	1070	24.0
41	1PA6228-4_F	1750	945	35.0
42	1PA6228-4_L	2900	710	40.5
43	1PL6184-4_B	400	585	6.9
44	1PL6184-4_D	1150	540	12.1
45	1PL6184-4_F	1750	486	16.6
46	1PL6184-4_L	2900	372	20.9
47	1PL6186-4_B	400	752	9.0
48	1PL6186-4_D	1150	706	15.8
49	1PL6186-4_F	1750	682	23.1
50	1PL6186-4_L	2900	494	28.4
51	1PL6224-4_B	400	1074	11.7
52	1PL6224-4_D	1150	997	21.8
53	1PL6224-4_F	1750	900	29.2
54	1PL6224-4_L	2900	675	36.5
55	1PL6226-4_B	400	1361	14.5
56	1PL6226-4_D	1150	1287	27.5
57	1PL6226-4_F	1750	1091	35.5
58	1PL6226-4_L	2900	889	48.5
59	1PL6228-4_B	400	1719	18.1
60	1PL6228-4_D	1150	1578	33.4
61	1PL6228-4_F	1750	1448	47.3
62	1PL6228-4_L	2900	988	53.4

Table 8-4 Motor list 1PA6 / 1PL6

8.6 Complete parameterization

To make full use of the complete functionality of the inverter/converter, parameterization must be carried out in accordance with the "Compendium". You will find the relevant instructions, function diagrams and complete lists of parameters, binectors and connectors in the Compendium.

Language	Compendium order number
German	6SE7080-0QX50
English	6SE7087-6QX50
French	6SE7087-7QX50
Spanish	6SE7087-8QX50
Italian	6SE7087-2QX50

9 Maintenance

WARNING



SIMOVERT MASTERDRIVES units are operated at high voltages. All work carried out on or with the equipment must conform to all the national electrical codes (VGB 4 in Germany). Maintenance and service work may only be executed by qualified personnel.

Only spare parts authorized by the manufacturer may be used. The prescribed maintenance intervals and also the instructions for repair and replacement must be complied with. Hazardous voltages are still present in the drive units up to 5 minutes after the converter has been powered down due to the DC link capacitors. Thus, the unit or the DC link terminals must not be worked on until at least after this delay time. The power terminals and control terminals can still be at hazardous voltage levels even when the motor is stationary.

If it is absolutely necessary that the drive converter be worked on when powered-up:

- ◆ Never touch any live parts.
- ◆ Only use the appropriate measuring and test equipment and protective clothing.
- ◆ Always stand on an ungrounded, isolated and ESD-compatible pad.

If these warnings are not observed, this can result in death, severe bodily injury or significant material damage.

9.1 Replacing the fan

A fan is mounted at the lower section of the inverter for cooling the power section.

The fan is fed by the 24 V supply voltage and switched on and off by electronic control according to the heat sink temperature.

The fan is designed for a service life of $L_{10} \geq 35,000$ hours and an ambient temperature of $T_u = 45$ °C. It must be exchanged in good time to ensure the availability of the unit.

9.1.1 Replacing the fan in units up to 90 mm wide

Removal

To replace the fan, the inverter has to be disconnected from the supply and removed.

After removing the X20 connector which is protected against polarity reversal and carefully bending up the fastening clips the fan can be taken out.

Installation

When installing the new fan, attention has to be paid to the correct direction of the air flow. The air must flow into the inside of the unit (see directional arrow on the fan housing).

9.1.2 Replacing the fan in units 135 mm wide

Removal

- ◆ Before you exchange the fan, the converter must be disconnected from the power supply and removed.
- ◆ Undo the four fan mounting screws and take out the fan.
- ◆ Disconnect the leads on the fan.

Fitting the new fan

- ◆ Fit the new fan in the reverse order.
- ◆ Make sure that the arrow indicating the direction of air flow points to the inside of the unit.

NOTE

Make sure that the fan leads are connected the right way round. Otherwise the fan will not operate!

9.1.3 Replacing the fan in units up to 180 mm wide

Two fans are mounted on the lower side of the converter, an **internal fan** for cooling the control electronics and a **unit fan** for cooling the power section.

Both fans are fed by the 24 V voltage supply; the unit fan is switched on and off by electronic control according to the heat sink temperature.

The fans are designed for a service life of $L_{10} \geq 35\,000$ hours at an ambient temperature of $T_u = 45\text{ °C}$. They must be replaced in good time to ensure the availability of the unit.

Internal fan

- ◆ Before removing the old fan and fitting a new one, make sure that the inverter is disconnected from the power supply.
- ◆ Opening the unit:
 - Loosen the 2 mounting screws in the front at the top of the unit. There is no need to take the screws right out. Slots are provided in the housing to allow the front of the unit to be released when the screws have been loosened.
 - Carefully swing the front of the unit forwards (to an angle of about 30°) away from the housing.
 - On the power section, open the locking lever on the ribbon cable connector to the control electronics.
 - Move the cover forwards and take it off.
- ◆ Remove the fan connection X20 on the power section.
- ◆ Undo the four fan mounting screws and take out the fan.
- ◆ Fit the new fan by reversing this sequence of operations. Make sure that the arrow indicating the direction of rotation is pointing to the inside of the unit.

Unit fan

- ◆ The converter must be disconnected from the power supply and removed before the fan can be replaced.
- ◆ Undo the four fan mounting screws and take out the fan.
- ◆ Disconnect the leads on the fan.
- ◆ Fit the new fan in the reverse order.
- ◆ Make sure that the arrow indicating the direction of air flow points to the inside of the unit.

NOTE

Make sure that the leads to the fan are connected the right way round. Otherwise the fan will not operate!

10 Forming

If a unit has been non-operational for more than one year, the DC link capacitors have to be newly formed. If this is not carried out, the unit can be damaged when the line voltage is powered up.

If the unit was started-up within one year after having been manufactured, the DC link capacitors do not have to be re-formed. The date of manufacture of the unit can be read from the serial number.

(Example: RFU-J60147512345)

How the serial number is made up

Position	Example	Meaning
1 to 3	RFU-	Place of manufacture
4	J	1997
	K	1998
	L	1999
	M	2000
5	1 to 9	January to September
	O	October
	N	November
	D	December
6 to 15		Not relevant for forming

The following applies for the above example:
Manufacture took place in June 1997.

During forming, the DC link of the unit is connected up via a rectifier, a smoothing capacitor and a resistor.

As a result, the DC link capacitors receive a defined voltage and a limited current, and the internal conditions necessary for the function of the DC link capacitors are restored.

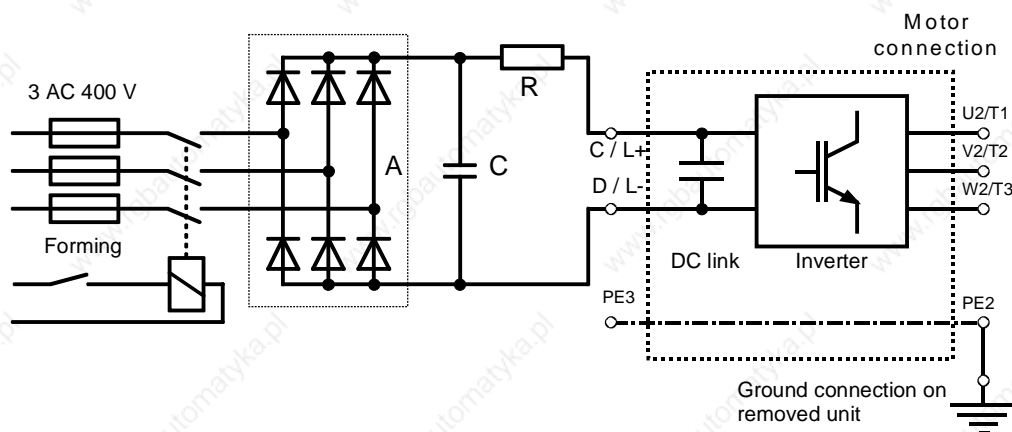

Fig. 10-1 Forming circuit

Components for the forming circuit (suggestion)

- ◆ Rectifier (A): SKD 62/16
- ◆ Resistor (R): 470 Ω , 100 W
- ◆ Capacitor (C): 22 nF, 1600 V

WARNING



The unit has hazardous voltage levels up to 5 minutes after it has been powered down due to the DC link capacitors. The unit or the DC link terminals must not be worked on until at least after this delay time.

Procedure

- ◆ Before forming the DC link capacitors, you must remove the unit or remove the front and middle DC link busbars (C/L+ and D/L-).
- ◆ After you have removed the unit, connect PE2 to ground. Built-in units are to be grounded to busbar PE3.
- ◆ Connect up the forming equipment as shown in the circuit diagram.
- ◆ Switch on the forming circuit. The forming duration depends on the length of time that the inverter has been out of action.

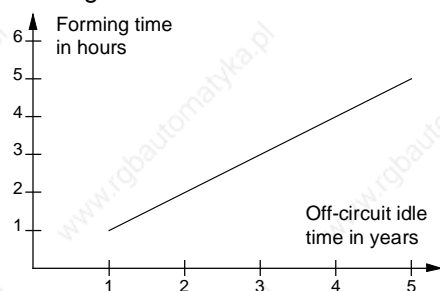

Fig. 10-2 Forming time as a function of converter idle time

11 Technical Data

EC Low-Voltage Directive 73/23/EEC and RL93/68/EEC	EN 50178
EC EMC Directive 89/336/EEG	EN 61800-3
EC Machinery Safety Directive 89/392/EEC	EN 60204-1
Approvals	UL: E 145 153 CSA: LR 21 927 (For units with rated motor output from 5.5 kW: in preparation)
Type of cooling	Air-cooled with installed fan
Permissible ambient or coolant temperature	
<ul style="list-style-type: none"> • During operation • During storage • During transport 	0° C to +45° C (32° F to 113° F) (to 50° C, see fig. "Derating curves") -25° C to +55° C (-13° F to 131° F) -25° C to +70° C (-13° F to 158° F)
Installation altitude	≤ 1000 m above sea level (100 per cent loadability) > 1000 m to 4000 m above sea level (Loadability: see fig. "Derating curves")
Permissible humidity rating	Relative air humidity ≤ 95 % during transport and storage ≤ 85 % in operation (condensation not permissible)
Environmental conditions to DIN IEC 721-3-3	Climate: 3K3 Chemically active substances: 3C1
Pollution degree	Pollution degree 2 to IEC 664-1 (DIN VDE 0110, Part 1), Moisture condensation during operation is not permissible
Overvoltage category	Category III to IEC 664-1 (DIN VDE 0110, Part 2)
Type of protection	IP20 EN 60529
Protection class	Class 1 to EN 536 (DIN VDE 0106, Part 1)
Shock-hazard protection	EN 60204-1 and to DIN VDE 0106 Part 100 (VBG4)
Radio interference level	According to EN 61800-3
<ul style="list-style-type: none"> • Standard • Options 	No radio interference suppression Radio interference suppression filter for class B1 or A1 to EN 55011
Noise immunity	Industrial sector to EN 61800-3
Paint	Indoor duty

<p>Mechanical strength</p> <p>- Vibration</p> <p> During stationary duty: const. amplitude</p> <ul style="list-style-type: none"> • deflection • acceleration <p> During transport:</p> <ul style="list-style-type: none"> • deflection • acceleration <p>- Shocks</p> <p>- Drop</p>	<p>According to DIN IEC 68-2-6</p> <p>0.15 mm in frequency range 10 Hz to 58 Hz (housing width ≤ 90 mm)</p> <p>0.075 mm in frequency range 10 Hz to 58 Hz (housing width ≥ 135 mm)</p> <p>9.8 m/s² in frequency range > 58 Hz to 500 Hz (housing width ≥ 135 mm)</p> <p>19.6 m/s² housing width ≤ 90 mm</p> <p>3.5 mm in frequency range 5 Hz to 9 Hz</p> <p>9.8 m/s² in frequency range > 9 Hz to 500 Hz</p> <p>According to DIN IEC 68-2-27 / 08.89</p> <p>30 g, 16 ms half-sine shock</p> <p>According to DIN IEC 68-2-31 / 04.84 onto a surface and onto an edge</p>
-----------------------------------------------------------------------------------------------------------------------------------------------------------------------------------------------------------------------------------------------------------------------------------------------------------------------------------------------------------	---------------------------------------------------------------------------------------------------------------------------------------------------------------------------------------------------------------------------------------------------------------------------------------------------------------------------------------------------------------------------------------------------------------------------------------------------------------------------------------------------------------------------------------------------------------------------------------------------------------------------------

Table 11-1 General data

Designation	Value					
	12-0TP50	14-0TP50	16-0TP50	21-0TP50	21-3TP50	
Order No. 6SE70...						
Rated voltage [V] • Input • Output	DC 510 (- 15 %) to 650 (+ 10 %) 3 AC 0 up to rated input voltage x 0.64					
Rated frequency [Hz] • Input • Output	--- 0 ... 400					
Rated current [A] • Input • Output	2.5 2.0	5.0 4.0	7.5 6.1	12.5 10.2	15.7 13.2	
Motor rated power [kW]	0.75	1.5	2.2	4.0	5.5	
Auxiliary power supply [V]	DC 24 (20 - 30)					
Max. aux. current requirement [A] • Standard version at 20 V • Maximum version at 20 V	0.8 1.5					
Pulse frequency fp [kHz]	5.0 to 10.0 (see fig. "Derating curves")					
Load class II to EN 60 146-1-1						
Base load current [A]	0.91 x rated output current					
Base load duration [s]	300					
Overload current [A]	1.6 x rated output current					
Overload duration [s]	30					
Extra short-time loading						
Short-time current (fp = 5 kHz) [A]	3 x rated output current					
Short-time current (fp = 10 kHz)[A]	2.1 x rated output current					
Short-time cycle [s]	1					
Short-time duration [ms]	250					
Losses, cooling						
Efficiency η (rated operation)						
Power loss (fp = 10 kHz) [kW]	0.066	0.086	0.116	0.156	0.240	
Cooling air requirement [m³/s]	0.002	0.009	0.009	0.018	0.018	
Pressure drop Δp [Pa]	10	20	20	15	15	
Sound pressure levels, types of construction, dimensions, weights						
Sound pressure level [dB(A)]	18	40	40	37	37	
Dimensions [mm] • Width • Height • Depth	45 360 260	67.5 360 260	67.5 360 260	90 360 260	135 360 260	
Weight approx. [kg]	3	4	4	5	9.1	

Table 11-2 Technical data of inverter (Part 1)

Designation	Value				
	21-8TP50	22-6TP50	23-4TP50	23-8TP50	
Order No. 6SE70...					
Rated voltage [V] • Input • Output	DC 510 (- 15 %) to 650 (+ 10 %) 3 AC 0 up to rated input voltage x 0.64				
Rated frequency [Hz] • Input • Output	--- 0 ... 400				
Rated current [A] • Input • Output	20.8 17.5	30.4 25.5	40.5 34.0	44.6 37.5	
Motor rated power [kW]	7.5	11.0	15.0	18.5	
Auxiliary power supply [V]	DC 24 (20 - 30)				
Max. aux. current requirement [A] • Standard version at 20 V • Maximum version at 20 V	0.8 2.1		0.8 2.4		
Pulse frequency fp [kHz]	5.0 to 10.0 (see fig. "Derating curves")				
Load class II to EN 60 146-1-1					
Base load current [A]	0.91 x rated output current				
Base load duration [s]	300				
Overload current [A]	1.6 x rated output current				
Overload duration [s]	30				
Extra short-time loading					
Short-time current (fp = 5 kHz) [A]	3 x rated output current				
Short-time current (fp = 10 kHz)[A]	2.1 x rated output current				
Short-time cycle [s]	1				
Short-time duration [ms]	250				
Losses, cooling					
Efficiency η (rated operation)					
Power loss (fp = 10 kHz) [kW]	0.300	0.410	0.550	0.660	
Cooling air requirement [m³/s]	0.041	0.041	0.061	0.061	
Pressure drop Δp [Pa]	30	30	30	30	
Sound pressure levels, types of construction, dimensions, weights					
Sound pressure level [dB(A)]	48	48	59	59	
Dimensions [mm] • Width • Height • Depth	135 360 260	135 360 260	180 360 260	180 360 260	
Weight approx. [kg]	9.2	9.3	13.8	14.0	

Table 11-3 Technical data of inverter (part 2)

Derating curves

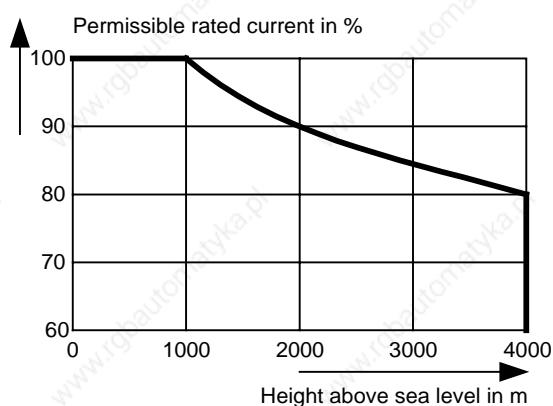
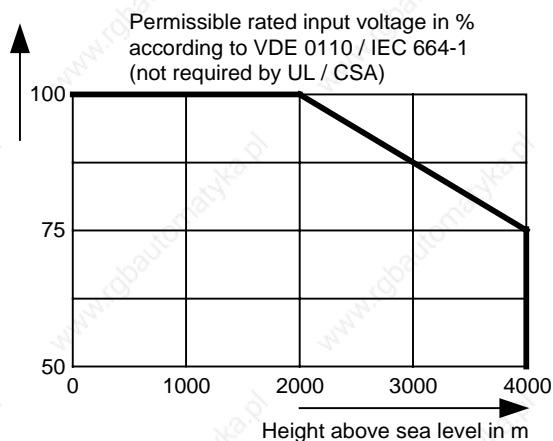

Height [m]	Derating factor K1
1000	1.0
2000	0.9
3000	0.845
4000	0.8

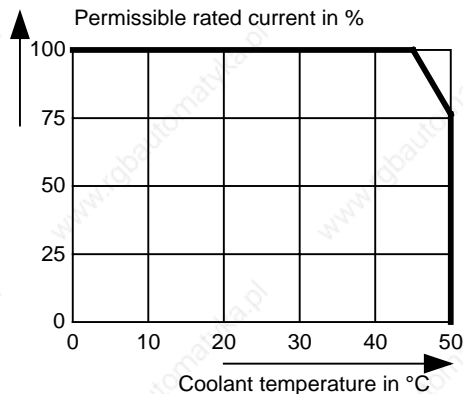

Temp [°C]	Derating factor K2
50	0.879
45	1.0
40	1.125
35	1.25 *
30	1.375 *
25	1.5 *

*See note below

Fig. 11-1 Derating curves

The derating of the permissible rated current for installation altitudes of over 1000 m and at ambient temperatures below 45 °C is calculated as follows:

Total derating = Derating_{altitude} x Derating_{ambient temperature}
 $K = K_1 \times K_2$

NOTE

It must be borne in mind that total derating must **not be greater** than 1!

Example: Altitude: 3000 m $K_1 = 0.845$
 Ambient temperature: 35 °C $K_2 = 1.25$
 \Rightarrow Total derating = 0.845 x 1.25 = 1.056 (= 1)

Rating plate

SIEMENS
MASTER DRIVES MC
 DC/AC DRIVE

Barcode MLFB

Bestellnummer: **6SE7012-0TP50-Z**
 Model number **Z = C10 + G10**

Barcode FID

Fabrik-Nr. Serial no. s RFU **H41547500011**

Eingang/Input **DC 510...650 V**

Ausgang/Output **3AC 0 - 380...480 V 0 - 400 Hz**

Dauerstrom/Cont. current **2 A**

Spitzenstrom/Peak current **6 A (0.25 s)**

Erz.Stand/Issue **A**

Techn. Opt.

Made in Germany

UL LISTED SM79 PWR.CONV.EQ. SP CE

Unit designation

List of unit options

Year of manufacture

Month of manufacture

Technology functions released, if cross is entered here

Fig. 11-2 Rating plate

Date of manufacture

The date of manufacture can be derived as follows:

Character	Year of manufacture:	Character	Month of manufacture
J	1997	1 to 9	January to September
K	1998	O	October
L	1999	N	November
M	2000	D	December

Table 11-4 Assignment of characters to the month and year of manufacture

Option codes

Option	Meaning	Option	Meaning
	SBP: Pulse encoder evaluation		CBP: Profibus
C11	Slot A	G11	Slot A
C12	Slot B	G12	Slot B
C13	Slot C	G13	Slot C
	SBR1: Resolver evaluation without pulse encoder simulation		CBC: CAN bus
C23	Slot C	G21	Slot A
	SBR2: Resolver evaluation with pulse encoder simulation	G22	Slot B
		G23	Slot C
C33	Slot C		EB1: Expansion Board 1
	SBM: Absolute-value encoder evaluation	G61	Slot A
C51	Slot A	G62	Slot B
C52	Slot B	G63	Slot C
C53	Slot C		EB2: Expansion Board 2
	SLB: SIMOLINK	G71	Slot A
G41	Slot A	G72	Slot B
G42	Slot B	G73	Slot C
G43	Slot C	K80	"Safe OFF" option

Table 11-5 Meaning of the option codes

12 Faults and Alarms

12.1 Faults

General information regarding faults

For each fault, the following information is available:

Parameter	r947	Fault number
	r949	Fault value
	r951	Fault list
	P952	Number of faults
	r782	Fault time

If a fault message is not reset before the electronic supply voltage is switched off, then the fault message will be present again when the electronic supply is switched on again. The unit cannot be operated without resetting the fault message. (Exception: Automatic restart has been selected, see P373).

Number / Fault	Cause	Counter-measure
F001 Main contactor checkback	The monitoring time of the main contactor checkback (P600) has expired.	<ul style="list-style-type: none"> - Check main contactor checkback - Clear main contactor checkback (P591.B = 0) - Increase monitoring time (P600)
F002 Pre-charging fault	The monitoring time of pre-charging has expired, i.e. the DC link voltage has not reached the setpoint within 3 secs.	<ul style="list-style-type: none"> - Check voltage connection (AC or DC) - Compare value in P070 and unit MLFB
F006 DC link overvoltage	Due to excessive DC link voltage, shutdown has occurred (shutdown threshold approx. 820 V)	Check the line voltage (AC-AC) or the input direct voltage (DC-AC). Compare value with P071 (Line Volts)
F008 DC link undervoltage	The lower limit value of 76% of the DC link voltage has been fallen short of.	<ul style="list-style-type: none"> - Check the line voltage (AC-AC) or the input direct voltage (DC-AC). Compare value with P071 (Line Volts) - Check input rectifier (AC-AC) - Check DC link
F011 Overcurrent	Overcurrent shutdown has occurred. The shutdown threshold has been exceeded.	<ul style="list-style-type: none"> - Check the converter output for short-circuit or earth fault - Check the load for an overload condition - Check whether motor and converter are correctly matched - Check whether the dynamic requirements are too high

Number / Fault	Cause	Counter-measure
F015 Motor blocked	<p>Motor is blocked/overloaded (current control), or has stalled (v/f characteristic):</p> <p>Static load is too high</p> <p>The fault is not generated until after the time entered in P805.</p> <p>Binector B0156 is set, in status word 2 r553 Bit 28.</p> <p>Whether the drive is blocked or not can be detected at P792 (Perm Deviation) and P794. P806 enables detection to be limited to "at standstill" (P806 = 1, only for current control) or to be completely de-activated (P806 = 2). In the case of current control, the precondition for this fault is that the torque limits (B0234) have been reached.</p> <p>In the case of slave drive, detection is de-activated.</p> <p>In the case of v/f control, the I(max) controller must be active.</p>	<ul style="list-style-type: none"> - Reduce the load - Release the brake - Increase current limits - Increase P805 Blocking Time - Increase the response threshold for the permissible deviation P792 - Increase torque limits or torque setpoint <p>v/f characteristic only:</p> <ul style="list-style-type: none"> - Reduce rate of acceleration - Check characteristic setting.
F017 SAFE OFF	SAFE OFF operating or failure of the 24 V power supply during operation (only for Compact PLUS units)	<p>Jumper applied for SAFE OFF?</p> <p>SAFE OFF checkback connected?</p> <p>On Compact PLUS units: check 24 V supply</p>
F020 Excess temperature of motor	<p>The motor temperature limit value has been exceeded.</p> <p>r949 = 1 Motor temperature limit value exceeded</p> <p>r949 = 2 Short-circuit in the motor temperature sensor cable or sensor defective</p> <p>r949 = 4 Wire break of motor temperature sensor cable or sensor defective</p>	<ul style="list-style-type: none"> - Temperature threshold adjustable in P381! - P131 = 0 -> fault de-activated - Check the motor (load, ventilation etc.) - The current motor temperature can be read in r009 (Motor Temperat.) - Check the sensor for cable break, short-circuit
F021 Motor I2t	Parameterized limit value of the I2t monitoring for the motor (P384.002) has been exceeded	<p>Check: Thermal time constant of motor P383 Mot ThermT-Const or motor I2t load limit P384.002.</p> <p>The I2t monitoring for the motor is automatically activated if P383 >=100s (=factory setting) and P381 > 220°C is set. Monitoring can be switched off by setting a value <100s in P383.</p>
F023 Excess temperature of inverter	The limit value of the inverter temperature has been exceeded	<ul style="list-style-type: none"> - Measure the air intake and ambient temperature. - Observe the derating curves at q > 50 °C (Compact PLUS) or 40 °C - Check whether the fan is running - Check that the air entry and discharge openings are not restricted
F025 UCE upper switch/UCE Phase L1	UCE upper switch (Compact PLUS) / UCE Phase L1 (chassis-type unit)	<ul style="list-style-type: none"> - Check the converter outputs for earth fault - Check the switch for "Safe OFF" on Compact units
F026 UCE lower switch/UCE Phase L2	UCE lower switch (Compact PLUS) / UCE Phase L2 (Compact, chassis)	<ul style="list-style-type: none"> - Check the converter outputs for earth fault - Check the switch for "Safe OFF" on Compact units

Number / Fault	Cause	Counter-measure
F027 Pulse resistor fault / UCE Phase L3	Pulse resistance fault (only Compact PLUS) / UCE Phase L3 (chassis)	- Check the converter outputs for earth fault - Check the switch for "Safe OFF" on Compact units
F035 External fault 1	Parameterizable external fault input 1 has been activated.	- Check whether there is an external fault - Check whether the cable to the corresponding digital output is interrupted - P575 (Src No ExtFault1)
F036 External fault 2	Parameterizable external fault input 2 has been activated.	- Check whether there is an external fault - Check whether the cable to the corresponding digital output is interrupted - P576 (Src No ExtFault2)
F038 Voltage OFF during parameter storage	A voltage failure has occurred during a parameter task.	Re-enter the parameter. The number of the parameter concerned is indicated in fault value r949.
F040 Internal fault of sequence control	Incorrect operating status	Replace the control board (CUMC) or the unit (Compact PUS).
F041 EEPROM fault	A fault has occurred during the storage of values in the EEPROM.	Replace the control board (CUMC) or the unit (Compact PLUS)
F042 Time slot overflow	The available calculating time of the time slot has been exceeded.	- Reduce pulse frequency - Calculate individual blocks in a slower sampling time
F043 DSP link	The link to the internal signal processor is interrupted	- Reduce pulse frequency (perhaps caused by calculating time overflow) - If fault re-occurs, replace the board/unit
F044 BICO manager fault	A fault has occurred in the softwiring of binectors and connectors	Fault value r949: >1000: Fault during connector softwiring >2000: Fault during binector softwiring - Voltage OFF and ON - Factory setting and new parameterization - Exchange the board 1028:Link memory is full. The link area between the two processors is full. No further connectors can be transferred. - Reduction of the linked connections between the two processors. Interface between the two processors is position control/setpoint conditioning i.e.softwires from and to the setpoint conditioning, position controller, speed controller, torque interface and current controller which are not necessary should be dissolved to reduce the link (value 0).
F045 HW fault on optional boards	A hardware fault has occurred during access to an optional board.	- Replace CU board (Compact, chassis units) - Replace the unit (Compact PLUS) - Check the connection between the subrack and the optional boards - Replace optional boards.
F046 Parameter coupling fault	A fault has occurred during the transfer of parameters to the DSP.	If fault re-occurs, replace the board/unit

Number / Fault	Cause	Counter-measure
<p>F051</p> <p>Encoder fault</p>	<p>- Signal amplitude of resolver or encoder is below the tolerance threshold</p> <p>- In the case of multiturn encoders (SSI/Endat) connection fault of the serial protocol</p>	<p>Resolver/encoder fault value r949:</p> <p>9 = Resolver signal missing</p> <p>28 = Voltage supply Encoder fault</p> <ul style="list-style-type: none"> - Short-circuit in encoder connection? - Encoder faulty? - Encoder incorrectly connected up? <p>29 = Encoder signal is missing</p> <ul style="list-style-type: none"> - Check encoder cable (faulty/torn off)? - Is shield of encoder cable connected ? - Encoder faulty? - Replace SBR/SBM - Replace unit or basic board - Is the correct cable being used in each case for the encoder/multiturn encoder? Encoders and multiturn encoders require different encoder cables! <p>Multiturn (SSI/EnDat):</p> <p>Fault value r949:</p> <p>30: Protocol fault CRC/Parity Check</p> <p>31: Timeout Protocol (EnDat)</p> <p>32: Neutral level fault</p> <p>33: Initialization of timeout</p> <ul style="list-style-type: none"> - Check parameterization (P149) - Check encoder cable (faulty / torn off)? - Encoder cable shield connected ? - Encoder faulty? - Replace SBR/SBM - Replace unit or basic board <p>34: Address wrong (only EnDat)</p> <p>Writing or reading of parameters not successful, check address and MRS code (P149)</p> <p>40-48: Encoder alarms (only EnDat)</p> <p>Check voltage supply to encoder, battery change on battery-backed-up systems, encoder faulty?</p> <p>49: Alarm bit set</p> <p>Parameterization (P149), Encoder alarm</p> <p>50-59: Alarms EnDat encoder</p> <p>Fault value + 100 designates the corresponding faults of the external encoder.</p>
<p>F053</p> <p>Parameter fault in follow-up task</p>	<p>After changes have been made to parameters, a fault has occurred during the calculation of dependent parameters.</p>	<p>No remedy</p>

Number / Fault	Cause	Counter-measure
F054 Encoder board initialization fault	A fault has occurred during initialization of the encoder board.	Fault value r949: 1: Board code is incorrect 2: TSY not compatible 3: SBP not compatible 4: SBR not compatible 5: SBM not compatible 6: SBM initialization timeout 7: Board double 20: TSY board double 21: SBR board double 23: SB board three-fold 24: SBP board three-fold 30: SBR board slot incorrect 31: SBM board slot incorrect 32: SBP board slot incorrect 40: SBR board not present 41: SBM board not present 42: SBP board not present 50: Three encoder boards 60: internal fault
F056 SIMOLINK telegram failure	Communication on the SIMOLINK ring is disturbed.	- Check the fiber-optic cable ring - Check whether an SLB in the ring is without voltage - Check whether an SLB in the ring is faulty - Check P741 (SLB TIgOFF)
F058 Parameter fault Parameter task	A fault has occurred during the processing of a parameter task.	No remedy
F059 Parameter fault after factory setting/init.	A fault has occurred in the initialization phase during the calculation of a parameter.	The number of the inconsistent parameter is indicated in fault value r949. Correct this parameter (ALL indices) and switch voltage off and on again. Several parameters may be affected, i.e. repeat process.
F060 MLFB is missing during initial loading	Is set if parameter P070 is at zero when INITIAL LOADING is exited.	Enter correct MLFB after acknowledging the fault (power section, initial loading)
F061 Incorrect parameterization	A parameter which has been entered during drive setting is in the non-permissible range.	The number of the inconsistent parameter is indicated in fault value r949 (e.g. motor encoder = pulse encoder in the case of brushless DC motors) -> correct this parameter.
F063 PIN is missing	The synchronization or positioning technology functions have been activated without an authorization being present (PIN)	- Deactivate synchronization or positioning - Enter the PIN (U2977)
F065 SCom telegram failure	No telegram has been received at an SCom interface (SCom/USS protocol) within the telegram failure time.	Fault value r949: 1 = Interface 1 (SCom1) 2 = Interface 2 (SCom2) Check the connection of PMU -X300 or X103 / 27,28 (Compact, chassis unit) Check the connection of X103 or X100 / 35,36 (Compact PLUS unit) Check "SCom/SCB TIgOff" P704.01 (SCom1) or P704.02 (SCom2)

Number / Fault	Cause	Counter-measure
F070 SCB initialization fault	A fault has occurred during initialization of the SCB board.	Fault value r949: 1: Board code incorrect 2: SCB board not compatible 5: Error in configuration data 6: Initialization timeout 7: SCB board double 10: Channel error
F072 EB initialization fault	A fault has occurred during initialization of the EB board.	Fault value r949: 2: 1st EB1 not compatible 3: 2nd EB1 not compatible 4: 1st EB2 not compatible 5: 2nd EB2 not compatible 21: Three EB1 boards 22: Three EB2 boards 110: Fault on 1st EB1 120: Fault on 2nd EB1 210: Fault on 1st EB2 220: Fault on 2nd EB2
F073 AnInp1SL1 not Compact PLUS	4 mA at analog input 1, slave 1 fallen short of	Check the connection of the signal source to the SC11 (slave 1) -X428: 4, 5.
F074 AnInp2 SL1 not Compact PLUS	4 mA at analog input 2, slave 1 fallen short of	Check the connection of the signal source to the SC11 (slave 1) -X428: 7, 8.
F075 AnInp3 SL1 not Compact PLUS	4 mA at analog input 3, slave 1 fallen short of	Check the connection of the signal source to the SC11 (slave 1) -X428: 10, 11.
F076 AnInp1 SL2 not Compact PLUS	4 mA at analog input 1, slave 2 fallen short of	Check the connection of the signal source to the SC11 (slave 2) -X428: 4, 5.
F077 AnInp2 SL2 not Compact PLUS	4 mA at analog input 2, slave 2 fallen short of	Check the connection of the signal source to the SC11 (slave 2) -X428: 7, 8.
F078 AnInp3 SL2 not Compact PLUS	4 mA at analog input 3, slave 2 fallen short of	Check the connection of the signal source to the SC11 (slave 2) -X428: 10, 11.
F079 SCB telegram failure not Compact PLUS	No telegram has been received by the SCB (USS, peer-to-peer, SCI) within the telegram failure time.	- Check the connections of the SCB1(2). - Check P704.03"SCom/SCB TIg OFF" - Replace SCB1(2) - Replace CU (-A10)

Number / Fault	Cause	Counter-measure
F080 TB/CB initialization fault	Fault during initialization of the board at the DPR interface	Fault value r949: 1: Board code incorrect 2: TB/CB board not compatible 3: CB board not compatible 5: Error in configuration data 6: Initialization timeout 7: TB/CB board double 10: Channel error Check the T300/CB board for correct contacting and check the CB initialization parameter: - P918.01 CB Bus Address, - P711.01 to P721.01 CB parameters 1 to 11
F081 OptBrdHeartbeat-Counter	Heartbeat-counter of the optional board is no longer being processed	Fault value r949: 0: TB/CB heartbeat-counter 1: SCB heartbeat-counter 2: Additional CB heartbeat-counter - Acknowledge the fault (whereby automatic reset is carried out) - If the fault re-occurs, replace the board concerned (see fault value) - Replace ADB - Check the connection between the subrack and the optional boards (LBA) and replace, if necessary
F082 TB/CB telegram failure	No new process data have been received by the TB or the CB within the telegram failure time.	Fault value r949: 1 = TB/CB 2 = additional CB - Check the connection to TB/CB - Check P722 (CB/TB TlgOFF) - Replace CB or TB
F085 Add. CB initialization fault	A fault has occurred during initialization of the CB board.	Fault value r949: 1: Board code incorrect 2: TB/CB board not compatible 3: CB board not compatible 5: Error in configuration data 6: Initialization timeout 7: TB/CB board double 10: Channel error Check the T300 / CB board for correct contacting and check the CB initialization parameters: - P918.02 CB Bus Address, - P711.02 to P721.02 CB Parameters 1 to 11
F087 SIMOLINK initialization fault	A fault has occurred during initialization of the SLB board.	- Replace CU - Replace SLB
F114 Mld OFF	The converter has automatically stopped the automatic measurement due to the time limit up to power-up having been exceeded or due to an OFF command during the measurement, and has reset the function selection in P115.	Re-start with P115 function selection = 2 "Motor identification at standstill". The ON command must be given within 20 sec. after the alarm message A078 = standstill measurement has appeared. Cancel the OFF command and re-start measurement.
F116 Technology board fault not Compact PLUS	See TB documentation	See TB documentation

Number / Fault	Cause	Counter-measure
F117 Technology board fault	See TB documentation	See TB documentation
F118 Technology board fault not Compact PLUS	See TB documentation	See TB documentation
F119 Technology board fault not Compact PLUS	See TB documentation	See TB documentation
F120 Technology board fault not Compact PLUS	See TB documentation	See TB documentation
F121 Technology board fault not Compact PLUS	See TB documentation	See TB documentation
F122 Technology board fault not Compact PLUS	See TB documentation	See TB documentation
F123 Technology board fault not Compact PLUS	See TB documentation	See TB documentation
F124 Technology board fault not Compact PLUS	See TB documentation	See TB documentation
F125 Technology board fault not Compact PLUS	See TB documentation	See TB documentation
F126 Technology board fault not Compact PLUS	See TB documentation	See TB documentation
F127 Technology board fault not Compact PLUS	See TB documentation	See TB documentation
F128 Technology board fault not Compact PLUS	See TB documentation	See TB documentation
F129 Technology board fault not Compact PLUS	See TB documentation	See TB documentation
F130 Technology board fault not Compact PLUS	See TB documentation	See TB documentation

Number / Fault	Cause	Counter-measure
F131 Technology board fault not Compact PLUS	See TB documentation	See TB documentation
F132 Technology board fault not Compact PLUS	See TB documentation	See TB documentation
F133 Technology board fault not Compact PLUS	See TB documentation	See TB documentation
F134 Technology board fault not Compact PLUS	See TB documentation	See TB documentation
F135 Technology board fault not Compact PLUS	See TB documentation	See TB documentation
F136 Technology board fault not Compact PLUS	See TB documentation	See TB documentation
F137 Technology board fault not Compact PLUS	See TB documentation	See TB documentation
F138 Technology board fault not Compact PLUS	See TB documentation	See TB documentation
F139 Technology board fault not Compact PLUS	See TB documentation	See TB documentation
F140 Technology board fault not Compact PLUS	See TB documentation	See TB documentation
F141 Technology board fault not Compact PLUS	See TB documentation	See TB documentation
F142 Technology board fault not Compact PLUS	See TB documentation	See TB documentation
F143 Technology board fault not Compact PLUS	See TB documentation	See TB documentation

Number / Fault	Cause	Counter-measure
F144 Technology board fault not Compact PLUS	See TB documentation	See TB documentation
F145 Technology board fault not Compact PLUS	See TB documentation	See TB documentation
F146 Technology board fault not Compact PLUS	See TB documentation	See TB documentation
F147 Technology board fault not Compact PLUS	See TB documentation	See TB documentation
F148 Fault 1 Function blocks	An active signal is present at binector U061 (1).	Examine cause of fault, see function diagram 710
F149 Fault 2 Function blocks	An active signal is present at binector U062 (1).	Examine cause of fault, see function diagram 710
F150 Fault 3 Function blocks	An active signal (1) is present at binector U063.	Examine cause of fault, see function diagram 710
F151 Fault 4 Function blocks	An active signal is present at binector U064 (1).	Examine cause of fault, see function diagram 710
F255 Fault in EEPROM	A fault has occurred in the EEPROM.	Switch off the unit and switch it on again. If the fault re-occurs, replace the CU.

Table 12-1 Fault numbers, causes and their counter-measures

12.2 Alarms

The alarm message is periodically displayed on the PMU by A = alarm/ alarm message and a 3-digit number. An alarm cannot be acknowledged. It is automatically deleted once the cause has been eliminated. Several alarms can be present. The alarms are then displayed one after the other.

When the converter is operated with the OP1S operator control panel, the alarm is indicated in the lowest operating display line. The red LED additionally flashes (refer to the OP1S operating instructions).

Number / Alarm	Cause	Counter-measure
A001 Time slot overflow	The computing time work load is too high	- Reduce pulse frequency - Calculate individual function blocks in slower time slots (parameter U950 ff.)
A002 SIMOLINK start alarm	Start of the SIMOLINK ring is not functioning.	- Check the fiber-optic cable ring for interruptions - Check whether there is an SLB without voltage in the ring - Check whether there is a faulty SLB in the ring
A003 Drive not synchronous	Although synchronization has been activated, the drive is not synchronous. Possible causes are: - Poor communication connection (frequent telegram failures) - Slow bus cycle times (in the case of high bus cycle times or synchronization of slow time slots, synchronizing can last for 1-2 minutes in the worst case). - Incorrect wiring of the time counter (only if $P754 > P746 / T0$)	SIMOLINK (SLB): - Check r748 i002 and i003 = counters for CRC faults and timeout faults - Check the fiber-optic cable connection - Check P751 on the dispatcher (connector 260 must be softwired); Check P753 on the transceiver (corresponding SIMOLINK connector K70xx must be softwired).
A014 Simulation active alarm	The DC link voltage is not equal to 0 when the simulation mode is selected ($P372 = 1$).	- Set P372 to 0. - Reduce DC link voltage (disconnect the converter from the supply)
A015 External alarm 1	Parameterizable external alarm input 1 has been activated.	Check - whether the cable to the corresponding digital input has been interrupted. - parameter P588 Src No Ext Warn1
A016 External alarm 2	Parameterizable external alarm input 2 has been activated.	Check - whether the cable to the corresponding digital input has been interrupted. - parameter P588 Src No Ext Warn2
A017 SAFE OFF alarm active	SAFE OFF is detected in the READY states.	See F017 for causes/counter-measures.
A018 Encoder adjustment	Signal amplitude Resolver/encoder in the critical range.	See F051 for causes/counter-measures.
A019 Encoder data serial protocol	Connection fault of the serial protocol on multiturn encoders (SSI/Endat)	Serial protocol is defective on multiturn encoders. See F051 for causes/counter-measures.

Number / Alarm	Cause	Counter-measure
A022 Inverter temperature	The threshold for tripping an alarm has been exceeded.	- Measure intake air and ambient temperature. - Observe derating curves at $q > 50^{\circ}\text{C}$ (Compact PLUS) or 40°C - Check whether the fan is operating - Check whether the air entry and discharge openings are restricted.
A023 Motor temperature	The parameterizable threshold (P380) for tripping an alarm has been exceeded.	Check the motor (load, ventilation, etc.). Read off the current temperature in r009 Motor Temperat.
A024 I2t converter	If the current load state is maintained, a thermal overload of the converter occurs. The converter will lower the max. current limit (P129).	- Reduce converter load - Check r010 (Drive Utiliz)
A029 I2t motor	The parameterized limit value for the I2t monitoring of the motor has been exceeded.	Motor load cycle is exceeded! Check the parameters: P382 Motor Cooling P383 Mot Tmp T1 P384 Mot Load Limits
A033 Overspeed	The positive or negative maximum speed has been exceeded.	- Increase relevant maximum speed - Reduce regenerative load (see FD 480)
A034 Setpoint/actual value deviation	Bit 8 in r552 status word 1 of the setpoint channel. The difference between frequency setpoint/actual value is greater than the parameterized value and the control monitoring time has elapsed.	Check - whether an excessive torque requirement is present - whether the motor has been dimensioned too small. Increase values P792 Perm Deviation Frq/ set/actual DevSpeed and P794 Deviation Time
A036 Brake checkback "Brake still closed"	The brake checkback indicates the "Brake still closed" state.	Check brake checkback (see FD 470)
A037 Brake checkback "Brake still open"	The brake checkback indicates the "Brake still open" state.	Check brake checkback (see FD 470)
A042 Motor stall/lock	Motor is stalled or blocked. The alarm cannot be influenced by P805 "PullOut/BlickTime", but by P794 "Deviation Time"	Check - whether the drive is locked - Whether the drive has stalled
A049 No slave not Compact PLUS	At serial I/O (SCB1 with SCI1/2), no slave is connected or fiber-optic cable is interrupted or slaves are without voltage.	P690 SSCI AnaIn Conf - Check slave. - Check cable.
A050 Slave incorrect not Compact PLUS	At ser. I/O the slaves required according to a parameterized configuration are not present (slave number or slave type): Analog inputs or outputs or digital inputs or outputs have been parameterized which are not physically present.	Check parameter P693 (analog outputs), P698 (digital outputs). Check connectors K4101...K4103, K4201...K4203 (analog inputs) and binectors B4100...B4115, B4120...B4135, B4200...B4215, B4220...B4235 (digital inputs) for connecting.
A051 Peer baud rate not Compact PLUS	In a peer-to-peer connection a baud rate has been selected which is too high or too different.	Adjust the baud rate in conjunction with the SCB boards P701 SCom/SCB Baud Rate

Number / Alarm	Cause	Counter-measure
A052 Peer PcD L not Compact PLUS	In a peer-to-peer connection, a PcD length has been set which is too high (>5).	Reduce number of words P703 SCom/SCB PcD #
A053 Peer Lng f. not Compact PLUS	In a peer-to-peer connection, the pcD length of transmitter and receiver do not match.	Adjust the word length for transmitter and receiver P703 SCom/SCB PcD #
A057 TB Param not Compact PLUS	Occurs when a TB is logged on and present, but parameter tasks from the PMU, SCom1 or SCom2 have not been answered by the TB within 6 seconds.	Replace TB configuration (software)
A061 Alarm 1 Function blocks	An active signal is present at binector U065 (1).	Check cause of alarm (see FD 710)
A062 Alarm 2 Function blocks	An active signal is present at binector U066 (1).	Check cause of alarm (see FD 710)
A063 Alarm 3 Function blocks	An active signal is present at binector U067 (1).	Check cause of alarm (see FD 710)
A064 Alarm 4 Function blocks	An active signal is present at binector U068 (1).	Check cause of alarm (see FD 710)
A075	The measured values of the leakage measurement or of rotor resistance deviate significantly.	If individual measured values significantly deviate from the average values, they are automatically not taken into account for the calculation (for RI) or the value of the automatic parameterization remains (for Ls). It is only necessary to check the results for their plausibility in the case of drives with high requirements on torque or speed accuracy.
A078 Stands. Meas	The standstill measurement is executed when the converter is powered up. The motor can align itself several times in a certain direction with this measurement.	If the standstill measurement can be executed without any danger: - Power up the converter.
A081 CB alarm	See user manual for CB board	
A082 CB alarm	See user manual for CB board	
A083 CB alarm	See user manual for CB board	
A084 CB alarm	See user manual for CB board	
A085 CB alarm	See user manual for CB board	
A086 CB alarm	See user manual for CB board	
A087 CB alarm	See user manual for CB board	
A088 CB alarm	See user manual for CB board	

Number / Alarm	Cause	Counter-measure
A089 CB alarm	See user manual for CB board Alarm of the 2nd CB board corresponds to A81 of the 1st CB board	
A090 CB alarm	See user manual for CB board Alarm of the 2nd CB board corresponds to A82 of the 1st CB board	
A091 CB alarm	See user manual for CB board Alarm of the 2nd CB board corresponds to A83 of the 1st CB board	
A092 CB alarm	See user manual for CB board Alarm of the 2nd CB board corresponds to A84 of the 1st CB board	
A093 CB alarm	See user manual for CB board Alarm of the 2nd CB board corresponds to A85 of the 1st CB board	
A094 CB alarm	See user manual for CB board Alarm of the 2nd CB board corresponds to A86 of the 1st CB board	
A095 CB alarm	See user manual for CB board Alarm of the 2nd CB board corresponds to A87 of the 1st CB board	
A096 CB alarm	See user manual for CB board Alarm of the 2nd CB board corresponds to A88 of the 1st CB board	
A097 TB alarm 1 not Compact PLUS	See user manual for TB board	
A098 TB alarm 1 not Compact PLUS	See user manual for TB board	
A099 TB alarm 1 not Compact PLUS	See user manual for TB board	
A100 TB alarm 1 not Compact PLUS	See user manual for TB board	
A101 TB alarm 1 not Compact PLUS	See user manual for TB board	
A102 TB alarm 1 not Compact PLUS	See user manual for TB board	
A103 TB alarm 1 not Compact PLUS	See user manual for TB board	
A104 TB alarm 1 not Compact PLUS	See user manual for TB board	

Number / Alarm	Cause	Counter-measure
A105 TB alarm 1 not Compact PLUS	See user manual for TB board	
A106 TB alarm 1 not Compact PLUS	See user manual for TB board	
A107 TB alarm 1 not Compact PLUS	See user manual for TB board	
A108 TB alarm 1 not Compact PLUS	See user manual for TB board	
A109 TB alarm 1 not Compact PLUS	See user manual for TB board	
A110 TB alarm 1 not Compact PLUS	See user manual for TB board	
A111 TB alarm 1 not Compact PLUS	See user manual for TB board	
A112 TB alarm 1 not Compact PLUS	See user manual for TB board	
A113 TB alarm 2 not Compact PLUS	See user manual for TB board	
A114 TB alarm 2 not Compact PLUS	See user manual for TB board	
A115 TB alarm 2 not Compact PLUS	See user manual for TB board	
A116 TB alarm 2 not Compact PLUS	See user manual for TB board	
A117 TB alarm 2 not Compact PLUS	See user manual for TB board	

Number / Alarm	Cause	Counter-measure
A118 TB alarm 2 not Compact PLUS	See user manual for TB board	
A119 TB alarm 2 not Compact PLUS	See user manual for TB board	
A120 TB alarm 2 not Compact PLUS	See user manual for TB board	
A121 TB alarm 2 not Compact PLUS	See user manual for TB board	
A122 TB alarm 2 not Compact PLUS	See user manual for TB board	
A123 TB alarm 2 not Compact PLUS	See user manual for TB board	
A124 TB alarm 2 not Compact PLUS	See user manual for TB board	
A125 TB alarm 2 not Compact PLUS	See user manual for TB board	
A126 TB alarm 2 not Compact PLUS	See user manual for TB board	
A127 TB alarm 2 not Compact PLUS	See user manual for TB board	
A128 TB alarm 2 not Compact PLUS	See user manual for TB board	
A129 Axis does not exist - machine data 1 = 0	Machine data 1 (position encoder type/axis type) is 0 (axis does not exist). Effect: Operation of the axis is inhibited and the position controller is deactivated.	You must assign a valid value to machine data 1 in order to operate the axis.

Number / Alarm	Cause	Counter-measure
A130 Operating conditions do not exist	<p>The "in operation" [IOP] checkback signal was missing when a traversing command was initiated. The following causes inhibit the "in operation" checkback signal (status bit No.2, refer to function diagram sheet 200) :</p> <ul style="list-style-type: none"> -Control signals [OFF1], [OFF2], [OFF3] and/or "enable controller" [ENC] are not activated. -Checkback signals [OFF2] and/or [OFF3] are not activated. -A fault [FAULT] is active. <p>Effect: The traversing command is inhibited.</p>	<p>Activate control signals [OFF1], [OFF2], [OFF3] and "enable controller" [ENC].</p> <ul style="list-style-type: none"> -If checkback signals [OFF2] and/or [OFF3] are missing, check the supply of control word 1 (MASTERDRIVE function diagram, sheet 180). -Analyze the queued fault number [FAULT_NO], remedy the fault, and then cancel the fault using the acknowledge fault [ACK_F] control signal. <p>Note: To activate the "in operation" [IOP] status again, you must deactivate [OFF1] and then activate it again.</p>
A131 OFF1 missing	<p>Control signal [OFF1] was deactivated while a traversing command was being executed.</p> <p>Effect: The drive is brought to a standstill via a ramp (machine data 43: deceleration time during faults). There is a subsequent pulse disable.</p>	<p>Check the activation of control signal [OFF1] from the user program.</p>
A132 OFF2 missing	<ul style="list-style-type: none"> -Control signal [OFF2] was deactivated while a traversing command was being executed. -Checkback signal [OFF2] was deactivated while a traversing command was being executed. <p>Effect: The pulse disable is initiated immediately. If the motor is not braked, it coasts down.</p>	<ul style="list-style-type: none"> -Check the activation of control signal [OFF2] from the user program. -If checkback signal [OFF2] is missing, check the supply of control word 1 (MASTERDRIVE function diagram, sheet 180). <p>Note: To activate the "in operation" [IOP] status again, you must deactivate [OFF1] and then activate it again.</p>
A133 OFF3 missing	<ul style="list-style-type: none"> -Control signal [OFF3] was deactivated while a traversing command was being executed. -Checkback signal [OFF3] was deactivated while a traversing command was being executed. <p>Effect: The motor decelerates at the current limit. There is a subsequent pulse disable.</p>	<ul style="list-style-type: none"> -Check the activation of control signal [OFF3] from the user program. -If checkback signal [OFF3] is missing, check the supply of control word 1 (MASTERDRIVE function diagram, sheet 180). <p>Note: To activate the "in operation" [IOP] status again, you must deactivate [OFF1] and then activate it again.</p>
A134 Enable Controller ENC missing	<p>The "enable controller" [ENC] control signal was deactivated while a traversing command was being executed (control bit No.3 "Inverter Enable", refer to function diagram, sheet 180)</p> <p>Effect: The pulse disable is initiated immediately. If the motor is not braked, it coasts down.</p>	<p>Check the activation of the "enable controller" [ENC] control signal from the user program.</p>
A135 Actual position value not o.k	<p>Actual position value not o.k. from position sensing (B0070 / B0071)</p>	<ul style="list-style-type: none"> -Check interconnection of B0070 and B0071, -check position encoder and evaluation board, -check encoder cable.
A136 Machine data 1 changed - RESET necessary	<p>Machine data 1 (position encoder type/axis type) was changed.</p> <p>Effect: The activation of traversing commands is inhibited.</p>	<p>If machine data 1 has been changed, the "reset technology" [RST] control signal must be activated. Alternatively switch the MASTERDRIVES electronic power supply off and on again</p>

Number / Alarm	Cause	Counter-measure
<p>A137</p> <p>Axis assignment incorrect</p>	<p>The same axis assignment (machine data 2) was entered for several axes (M7 only, not significant for the F01 technology option).</p> <p>Effect: The activation of traversing commands is inhibited.</p>	<p>A unique axis assignment must be entered for all axes on an M7-FM. For example, it is not allowed to define two X axes.</p>
<p>A138</p> <p>Axis assignment of roll feed incorrect</p>	<p>The NC block contains an axis number which is defined as a roll feed axis but the axis type is defined as an incremental or absolute position encoder (machine data 1 = 1 or 2). (M7 only, not significant for the F01 technology option) .</p> <p>The NC block for a roll feed axis type (machine data 1 = 3) contains: -No axis number (X, Y, Z...) -An incorrect axis number</p> <p>Effect: NC program execution is inhibited or aborted.</p>	<p>-Axis type 1 or 2:The block is not allowed to contain an axis number which is defined as a roll feed (M7 only).</p> <p>-Axis type 3:The axis number of the roll feed must be specified in every NC block.</p>
<p>A140</p> <p>Following error in standstill</p>	<p>The following error limit for standstill was exceeded at standstill:</p> <p>-Following error monitoring - at standstill (machine data 14) was entered incorrectly.</p> <p>-The value entered for "in position - exact stop window" (machine data 17) is greater than the value in "following error monitoring - at standstill" (machine data 14).</p> <p>-The axis was pushed out of position mechanically.</p> <p>Effect: The position control system is deactivated and the axis decelerates via "deceleration time during errors" (machine data 43).</p>	<p>-Check and correct the machine data.</p> <p>-Optimize the speed/current controller,</p> <p>-Rectify mechanical problem.</p>
<p>A141</p> <p>Following error in motion</p>	<p>The following error limit for motion was exceeded during a traversing movement:</p> <p>-Following error monitoring - in motion (machine data 15) was entered incorrectly.</p> <p>-The mechanical system cannot follow the commands of the position controller.</p> <p>-Incorrect optimization of the position controller or speed controller.</p> <p>-The mechanical system is sluggish or blocked.</p> <p>Effect: The position control system is deactivated and the drive decelerates via "deceleration time during faults" (machine data 43).</p>	<p>-Check and correct the machine data.</p> <p>-Optimize the position controller or the speed controller.</p> <p>-Check the mechanical system.</p>

Number / Alarm	Cause	Counter-measure
A142 In position - timer monitoring	<p>The "in position - exact stop window" was not reached within the time specified in "in position - timer monitoring":</p> <ul style="list-style-type: none"> -In position - exact stop window (machine data 17) too small -In position - timer monitoring (machine data 16) too short -Position controller or speed controller not optimized -Mechanical causes <p>Effect: The position control system is deactivated.</p>	<ul style="list-style-type: none"> -Check and correct the machine data. -Optimize the position controller or speed controller. -Check the mechanical system.
A145 Actual-value disable not allowed - axis standstill	<p>The "digital input" with the "disable actual value" function was actuated while the roll feed was running.</p> <p>Effect: The axis movement is stopped via the deceleration ramp, the "disable actual value" function is not executed.</p>	<p>The "digital input" for "disable actual value" can only be actuated when the axis is stationary.</p>
A146 Direction of movement not allowed	<p>A positioning movement was aborted. When attempting to resume the movement at the point of interruption, the roll feed would have had to travel in the opposite direction to reach the programmed target position. This is inhibited by the setting of machine data 37 "response after abort".</p> <p>There are various possible reasons for the axis crossing the target position when a positioning movement is aborted:</p> <ul style="list-style-type: none"> -Motor coastdown -The axis was moved intentionally, e.g. in setup mode. <p>Effect: The axis movement is inhibited.</p>	<p>Move the axis in front of the target position in setup mode before continuing.</p>
A148 Deceleration = 0	<p>The current deceleration value is 0, e.g. because of a RAM storage error or an error in the technology firmware.</p> <p>Effect: The position control system is deactivated and the drive is decelerated via the "deceleration time during errors" (machine data 43).</p>	<p>This fault should not normally occur. It is used as an emergency stop feature for the technology software. Replace the hardware (M7; MCT).</p>
A149 Distance to go negative	<p>Internal error in the technology software.</p> <p>Effect: The position control system is deactivated and the drive is decelerated via the "deceleration time during errors" (machine data 43).</p>	<p>This fault should not normally occur. It is used as an emergency stop feature for the technology software.</p>

Number / Alarm	Cause	Counter-measure
<p>A150</p> <p>Slave axis already allocated to other master axis</p>	<p>The selected NC program contains a slave axis which is already being used by another master axis (M7 only, not significant for the F01 technology option).</p> <p>Example: NC program 1, started in axis X, contains NC blocks for axes X and Y. NC program 2 is started in axis Z and contains NC blocks for axes Z and Y. This program is denied with warning 150, because axis Y is already being used by program 1.</p> <p>Effect: NC program execution is inhibited or aborted.</p>	<p>The same slave axis cannot be used simultaneously by several NC programs.</p>
<p>A151</p> <p>Slave axis operating mode not allowed</p>	<p>The slave axis required by the master axis is not in "slave" mode (M7 only, not significant for the F01 technology option).</p> <p>Effect: NC program execution is inhibited or aborted, the axis is brought to a standstill via the deceleration ramp.</p>	<p>The slave axis must be switched to "slave" mode.</p>
<p>A152</p> <p>Slave axis operating mode changed</p>	<p>The "slave" mode was deselected in the slave axis during the traversing movement (M7 only, not significant for the F01 technology option).</p> <p>Effect: NC program execution is inhibited or aborted, the axis is brought to a standstill via the deceleration ramp.</p>	<p>The slave axis must remain switched to "slave" mode.</p>
<p>A153</p> <p>Error in slave axis</p>	<p>A warning is active in the slave axis required by the master axis (M7 only, not significant for the F01 technology option).</p> <p>Effect: NC program execution is inhibited or aborted, the axis is brought to a standstill via the deceleration ramp.</p>	<p>The NC program will only run if all of the axes it needs are error-free. To clear this warning, you must first clear all the warnings in the slave axis.</p>
<p>A154</p> <p>Follow-up mode in slave axis active</p>	<p>The "follow-up mode" [FUM] control signal is active in the slave axis required by the master axis. A slave axis which is switched to follow-up mode cannot be operated by the master axis (M7 only, not significant for the F01 technology option).</p> <p>Effect: NC program execution is inhibited or aborted, the axis is brought to a standstill via the deceleration ramp.</p>	<p>Deactivate follow-up mode in the slave axis.</p>
<p>A155</p> <p>Reset in slave axis active</p>	<p>The "reset" [RST] control signal is active in the slave axis required by the master axis. A slave axis with an active reset cannot be used by the master axis (M7 only, not significant for the F01 technology option).</p> <p>Effect: NC program execution is inhibited or aborted, the axis is brought to a standstill via the deceleration ramp.</p>	<p>Cancel the "reset" [RST] control signal in the slave axis.</p>

Number / Alarm	Cause	Counter-measure
A156 Axis type (MD1) of slave axis not allowed	An NC program was started in which a slave axis is defined as a roll feed axis type (M7 only, not significant for the F01 technology option). The warning is output in the master axis and indicates an illegal axis type in the slave axis. Effect: NC program execution is inhibited or aborted, the axis is brought to a standstill via the deceleration ramp.	Axes defined as roll feed axes can only be used in dedicated NC programs.
A160 Setup speed = 0	The value entered in level 1 or level 2 for the [F_S] velocity level in setup mode is zero. Effect: The axis movement is inhibited.	Define a permissible velocity level for level 1 and/or level 2. The permissible value range is between 0.01 [1000*LU/min] and "traversing velocity - maximum (machine data 23).
A161 Reference approach velocity = 0	The velocity value entered for "reference point - approach velocity" (machine data 7) is zero. Effect: The axis movement is inhibited.	Enter a permissible value for the approach velocity. The permissible value range is between 0.01 [1000*LU/min] and "traversing velocity - maximum (machine data 23).
A162 Reference point - reducing velocity = 0	The velocity value entered for "reference point - reducing velocity" (machine data 6) is zero. Effect: The axis movement is inhibited or stopped.	Enter a permissible value for the reference point -reducing velocity. The permissible value range is between 0.01 and 1000 [1000*LU/min].
A165 MDI block number not allowed	The MDI block number [MDI_NO] specified in the control signals is greater than 11. Effect: The axis movement is inhibited.	Define an MDI block number [MDI_NO] between 0 and 10.
A166 No position has been programmed in MDI mode	The "start" [STA] control signal was activated in MDI mode without initially transferring a positional value to the selected MDI block. Effect: The axis movement is inhibited.	Use the correct sequence: data transfer followed by axis start.
A167 No velocity has been programmed in MDI mode	The "start" [STA] control signal was activated in MDI mode without initially transferring a velocity value to the selected MDI block. Effect: The axis movement is inhibited.	Use the correct sequence: data transfer followed by axis start.
A168 G91 not allowed with MDI on the fly	G91 (incremental dimensions) was defined in the MDI block as the 1st G function for the MDI on-the-fly function. Effect: The axis movement is inhibited or stopped via the deceleration ramp.	The MDI on-the-fly function only allows G90 (absolute dimensions) as the 1st G function.
A169 Start conditions for flying MDI do not exist	-Control signal "reset technology" [RST] activated -Control signal "follow-up mode" [FUM] activated Effect: The "MDI on-the-fly" function is not executed.	Ensure that the control signals are activated correctly.
A170 Single block mode block does not exist	An NC block was started in single-block mode although a block has not yet been transferred. Effect: NC block execution is inhibited.	Transfer the block.

Number / Alarm	Cause	Counter-measure
A172 Program with this number does not exist	The program number specified in [PROG_NO] for automatic mode is not stored in the memory of the technology. Effect: NC program execution is inhibited.	-Transfer the program to the technology. -Select the correct program number.
A173 Program number not allowed	The program number specified in [PROG_NO] for automatic mode is not allowed. Effect: NC program execution is inhibited.	The permissible range for program numbers is between 1 and 200.
A174 Program number changed during traversing	The program number [PROG_NO] was changed while the program was running. Effect: NC program execution is aborted and the axis or axes are brought to a standstill via the deceleration ramp.	The program number must not be changed while the program is running.
A175 No block end programmed	The decoded NC block is not terminated with the following block identifier "0". You can use the "output actual values - decoder error location" task to read out the program number and block number where the block decoder detected an error. Effect: NC program execution is inhibited or aborted. Moving axes are stopped via the deceleration ramp.	Correct the block. The last block in the sequence must contain the following block identifier "0".
A177 Prog. number of block search forwd. does not exist	The program number for the main program (level 0), which was transferred with the block search function, does not exist. Effect: NC program execution is inhibited.	Specify an existing main program number.
A178 Program number of block search forward not allowed	-The program number for the main program (level 0), which was transferred with block search, is different from the selected program number. -No breakpoint is known for the "automatic block search" function (a program abort has not yet occurred). -A different program number is stored as the breakpoint for the "automatic block search" function. Effect: NC program execution is inhibited.	For the block search function, the selected program number [PROG_NO] must be specified as the program number for the main program.
A179 Prog.No.of block srch fwd level 1/2 does not exist	The subprogram number specified with block search for level 1 or level 2 does not exist. Effect: NC program execution is inhibited.	For the block search function, an existing program number must be specified as the subprogram number for level 1 or level 2.
A180 Prog.no. of block search forward level 1 <> cmd.	The subprogram number transferred with block search for level 1 is not the same as the subprogram number in the NC block. Effect: NC program execution is inhibited.	For the block search function, the subprogram number specified in the NC block must be specified as the subprogram number for level 1.
A181 Prog.no. of block search forward level 2 <> cmd.	The subprogram number transferred with block search for level 2 is not the same as the subprogram number in the NC block. Effect: NC program execution is inhibited.	For the block search function, the subprogram number specified in the NC block must be specified as the subprogram number for level 2.

Number / Alarm	Cause	Counter-measure
A183 Block no. of block search fwd l. 0 does not exist	The block number for the main program (level 0), which was transferred with block search, does not exist in the main program. Effect: NC program execution is inhibited.	For the block search function, an existing block number must be specified as the block number for the main program.
A184 Block no. of block search forward is no UP call	The block number for the main program (level 0), which was transferred with block search, does not contain a subprogram call for subprogram level 1. Effect: NC program execution is inhibited.	For the block search function, a block number with a subprogram call must be specified as the block number for the main program (level 0) if a block search is to be performed in subprogram level 1.
A185 Block no. of block search forward does not exist	The block number for subprogram level 1, which was transferred with block search, does not exist in the subprogram. Effect: NC program execution is inhibited.	For the block search function, a block number which exists in this subprogram must be specified as the block number for subprogram level 1.
A186 Block no of block search fwd level 1 is no UP call	The block number for subprogram level 1, which was transferred with block search, does not contain a subprogram call for subprogram level 2. Effect: NC program execution is inhibited.	For the block search function, a block number with a subprogram call must be specified as the block number for subprogram level 1 if a block search is to be performed in subprogram level 2.
A187 Block no. of block search forward does not exist	The block number for subprogram level 2, which was transferred with block search, does not exist in the subprogram. Effect: NC program execution is inhibited.	For the block search function, a block number which exists in this subprogram must be specified as the block number for subprogram level 2.
A188 Remaining no of loops block search fwd not allowed	The remaining loop count transferred with block search for subprogram level 1 or 2 is greater than the programmed loop count. Effect: NC program execution is inhibited.	For the block search function, it is only allowed to specify a remaining loop count between 0 and the programmed loop count-1.
A190 Digital input not programmed	The NC block which was read in contains the "inprocess measurement" or "set actual value on-the-fly" function, although a digital input has not been programmed for this function (machine data 45). Effect: NC program execution is inhibited or aborted, the axis is brought to a standstill via the deceleration ramp.	Program the digital input for the desired function.
A191 Digital input not actuated	Although the "external block change" function was programmed, the digital input was not actuated in order to trigger the external block change. Effect: The NC program is interrupted, the axis is brought to a standstill via the deceleration ramp.	-Correct the program. -Check the actuation of the digital input.

Number / Alarm	Cause	Counter-measure
<p>A195</p> <p>Negative overtravel reached</p>	<p>-Negative software limit switch position approached</p> <p>-"Software limit switches - negative" (machine data 12) entered incorrectly</p> <p>-The programmed position is less than the negative software limit switch.</p> <p>-"Reference point - coordinate" (machine data 3) is less than the negative software limit switch.</p> <p>-Incorrect encoder actual value</p> <p>Effect: The axis movement is stopped via the deceleration ramp.</p>	<p>-Check the machine data and the NC program.</p> <p>-Check the encoder actual value.</p>
<p>A196</p> <p>Positive overtravel reached</p>	<p>-Positive software limit switch position approached</p> <p>-"Software limit switches - positive" (machine data 13) entered incorrectly"</p> <p>-The programmed position is greater than the positive software limit switch</p> <p>-"Reference point - coordinate" (machine data 3) is greater than the positive software limit switch</p> <p>-Incorrect encoder actual value</p> <p>Effect: The axis movement is stopped via the deceleration ramp.</p>	<p>-Check the machine data and the NC programs.</p> <p>-Check the encoder actual value.</p>
<p>A200</p> <p>No position has been programmed in Automatic mode</p>	<p>No position has been programmed in the NC block for the roll feed version, although the axis number of the roll feed is specified.</p> <p>Effect: NC program execution is inhibited or aborted, the axis is brought to a standstill via the deceleration ramp.</p>	<p>The axis number and the positional value must be specified in every NC block for the roll feed version.</p>
<p>A201</p> <p>No velocity has been programmed in Automatic mode</p>	<p>The decoded NC block needs a path or axis velocity.</p> <p>Effect: NC program execution is inhibited or aborted, the axis is brought to a standstill via the deceleration ramp.</p>	<p>When using linear interpolation with path velocity (G01), a path velocity must be defined with F. When using chaining with axis velocity (G77), the axis velocities must be defined with FX, FY, etc. When using roll feed with axis velocity (G01), the velocity must be defined with F.</p>

Number / Alarm	Cause	Counter-measure
A202 Axis unknown	<p>An axis which does not exist was detected in the decoded NC block. A logical name (X, Y, Z, A, B, C) must be assigned to each axis with machine data 2 (axis assignment). Only these logical axis names can be used in the NC block. These errors cannot normally occur, since the logical axis names are verified when the NC blocks are entered.</p> <p>Exception: Machine data 2 (axis assignment) is changed afterwards.</p> <p>The NC program number and NC block number in which the NC block decoder detected the error can be read out with the "output actual values – decoder error location" task.</p> <p>Effect: NC program execution is inhibited or aborted, the axis is brought to a standstill via the deceleration ramp.</p>	Correct the NC block.
A203 1st G-function not allowed	<p>The NC block which was read in contains an illegal 1st G function.</p> <p>The NC program number and NC block number in which the NC block decoder detected the error can be read out with the "output actual values - decoder error location" task.</p> <p>Effect: The axis movement is inhibited or stopped via the deceleration ramp.</p>	<p>-MDI mode: Only G90 (absolute dimensions) or G91 (incremental dimensions) can be entered as the 1st G function. Only G91 is allowed for the roll feed version.</p> <p>-Automatic/single-block mode: Define a legal 1st G function according to the table (see the Programming Guide).</p>
A204 2nd G-function not allowed	<p>The NC block which was read in contains an illegal 2nd G function.</p> <p>The NC program number and NC block number in which the NC block decoder detected the error can be read out with the "output actual values - decoder error location" task.</p> <p>Effect: The axis movement is inhibited or stopped via the deceleration ramp.</p>	<p>-MDI mode: Only G30 to G39 (acceleration override) can be entered as the 2nd G function.</p> <p>-Automatic/single-block mode: Define a legal 2nd G function according to the table (see the Programming Guide).</p>
A205 3rd G-function not allowed	<p>The NC block which was read in contains an illegal 3rd G function.</p> <p>The NC program number and NC block number in which the NC block decoder detected the error can be read out with the "output actual values - decoder error location" task.</p> <p>Effect: The axis movement is inhibited or stopped via the deceleration ramp.</p>	<p>-MDI mode: No 3rd G function is allowed.</p> <p>-Automatic/single-block mode: Define a legal 3rd G function according to the table (see the Programming Guide).</p>

Number / Alarm	Cause	Counter-measure
<p>A206</p> <p>4th G-function not allowed</p>	<p>The NC block which was read in contains an illegal 4th G function.</p> <p>The NC program number and NC block number in which the NC block decoder detected the error can be read out with the "output actual values - decoder error location" task.</p> <p>Effect: The axis movement is inhibited or stopped via the deceleration ramp.</p>	<p>-MDI mode:No 4th G function is allowed.</p> <p>-Automatic/single-block mode:Define a legal 4th G function according to the table (see the Programming Guide).</p>
<p>A208</p> <p>D-number is not allowed</p>	<p>A D number greater than 20 was found in the decoded NC block.</p> <p>The NC program number and NC block number in which the NC block decoder detected the error can be read out with the "output actual values - decoder error location" task.</p> <p>Effect: The axis movement is inhibited or stopped via the deceleration ramp.</p>	<p>Correct the NC block.</p>
<p>A210</p> <p>Interpolation of 3 axes not allowed</p>	<p>The decoded NC block contains an interpolation of 3 or more axes.</p> <p>The NC program number and NC block number in which the NC block decoder detected the error can be read out with the "output actual values - decoder error location" task.</p> <p>Effect: NC program execution is inhibited or aborted, the axis is brought to a standstill via the deceleration ramp.</p>	<p>Correct the NC block. Only 2D interpolation is allowed.</p>
<p>A211</p> <p>Shortest distance G68 and G91 not allowed</p>	<p>G function G68 (shortest path for rotary axis) was detected in the decoded NC block, although G91 (incremental dimensions) is active.</p> <p>Example: N10 G91 G68 X20.000</p> <p>The NC program number and NC block number in which the NC block decoder detected the error can be read out with the "output actual values - decoder error location" task.</p> <p>Effect: NC program execution is inhibited or aborted, the axis is brought to a standstill via the deceleration ramp.</p>	<p>Correct the NC block.Function G68 can only be programmed in association with G90 (absolute dimensions).</p>

Number / Alarm	Cause	Counter-measure
A212 Special function and axis combination not allowed	<p>A different axis was programmed in the NC block following a special function (M7 only).</p> <p>Example: N10 G50 X100 F1000 N15 G90 Y200 incorrect N15 G90 X200 correct</p> <p>The NC program number and NC block number in which the NC block decoder detected the error can be read out with the "output actual values - decoder error location" task.</p> <p>Effect: NC program execution is inhibited or aborted, the axis is brought to a standstill via the deceleration ramp.</p>	Correct the NC program. The axis used in the NC block with the special function must also be programmed in the next NC block.
A213 Multiple D-number not allowed	<p>The decoded NC block contains several D numbers.</p> <p>Example: N1 G41 D3 D5.</p> <p>The NC program number and NC block number in which the NC block decoder detected the error can be read out with the "output actual values - decoder error location" task.</p> <p>Effect: NC program execution is inhibited or aborted, the axis is brought to a standstill via the deceleration ramp.</p>	Correct the NC block.
A214 Multiple acceleration behaviour not allowed	<p>The decoded NC block contains several mutually exclusive G functions from the acceleration override group (G30 to G39).</p> <p>Example: N1 G34 G35</p> <p>The NC program number and NC block number in which the NC block decoder detected the error can be read out with the "output actual values - decoder error location" task.</p> <p>Effect: NC program execution is inhibited or aborted, the axis is brought to a standstill via the deceleration ramp.</p>	Correct the NC block.
A215 Multiple special functions not allowed	<p>The decoded NC block contains several mutually exclusive G functions from the special function group (G87, G88, G89, G50, G51).</p> <p>Example: N1 G88 G50</p> <p>The NC program number and NC block number in which the NC block decoder detected the error can be read out with the "output actual values - decoder error location" task.</p> <p>Effect: NC program execution is inhibited or aborted, the axis is brought to a standstill via the deceleration ramp.</p>	Correct the NC block.

Number / Alarm	Cause	Counter-measure
<p>A216</p> <p>Multiple block transition not allowed</p>	<p>The decoded NC block contains several mutually exclusive G functions from the block transition group (G60, G64, G66, G67).</p> <p>Example: N1 G64 G66 X1.000 FX100.00</p> <p>The NC program number and NC block number in which the NC block decoder detected the error can be read out with the "output actual values - decoder error location" task.</p> <p>Effect: NC program execution is inhibited or aborted, the axis is brought to a standstill via the deceleration ramp.</p>	<p>Correct the NC block.</p>
<p>A217</p> <p>Multiple axis programming not allowed</p>	<p>The decoded NC block contains the same axis more than once.</p> <p>Example: N1 G90 G01 X100.000 X200.000 F100.00</p> <p>The NC program number and NC block number in which the NC block decoder detected the error can be read out with the "output actual values - decoder error location" task.</p> <p>Effect: NC program execution is inhibited or aborted, the axis is brought to a standstill via the deceleration ramp.</p>	<p>Correct the NC block.</p>
<p>A218</p> <p>Multiple path condition not allowed</p>	<p>The decoded NC block contains several mutually exclusive G functions from the preparatory function group (G00/G01/G76/G77).</p> <p>Example: N1 G01 (linear interpolation) G77 (chaining) X10 F100.</p> <p>The NC program number and NC block number in which the NC block decoder detected the error can be read out with the "output actual values - decoder error location" task.</p> <p>Effect: NC program execution is inhibited or aborted, the axis is brought to a standstill via the deceleration ramp.</p>	<p>Correct the NC block.</p>
<p>A219</p> <p>Multiple dimensions specification not allowed</p>	<p>The decoded NC block contains several mutually exclusive G functions from the dimensional notation group (G90/G91).</p> <p>Example: N1 G90 G91.</p> <p>The NC program number and NC block number in which the NC block decoder detected the error can be read out with the "output actual values - decoder error location" task.</p> <p>Effect: NC program execution is inhibited or aborted, the axis is brought to a standstill via the deceleration ramp.</p>	<p>Correct the NC block.</p>

Number / Alarm	Cause	Counter-measure
<p>A220</p> <p>Multiple zero offset selection not allowed</p>	<p>The decoded NC block contains several mutually exclusive G functions from the zero offset group (G53 to G59).</p> <p>Example: N1 G54 G58</p> <p>The NC program number and NC block number in which the NC block decoder detected the error can be read out with the "output actual values - decoder error location" task.</p> <p>Effect: NC program execution is inhibited or aborted, the axis is brought to a standstill via the deceleration ramp.</p>	<p>Correct the NC block.</p>
<p>A221</p> <p>Multiple tool offset selection not allowed</p>	<p>The decoded NC block contains several mutually exclusive G functions from the tool offset selection group (G43/G44).</p> <p>Example: N1 G43 G44 D2</p> <p>The NC program number and NC block number in which the NC block decoder detected the error can be read out with the "output actual values - decoder error location" task.</p> <p>Effect: NC program execution is inhibited or aborted, the axis is brought to a standstill via the deceleration ramp.</p>	<p>Correct the NC block.</p>
<p>A223</p> <p>Subprogram number does not exist</p>	<p>The decoded NC block contains a subprogram call, however the NC program which was called does not exist in the memory of the technology.</p> <p>Effect: NC program execution is inhibited or aborted, the axis is brought to a standstill via the deceleration ramp.</p>	<p>Correct the NC block.</p>
<p>A224</p> <p>Subprogram nesting depth not allowed</p>	<p>The permissible nesting depth of subprograms was exceeded. Recursive calling of subprograms.</p> <p>The NC program number and NC block number in which the NC block decoder detected the error can be read out with the "output actual values - decoder error location" task.</p> <p>Effect: NC program execution is inhibited or aborted, the axis is brought to a standstill via the deceleration ramp.</p>	<p>Correct the NC program.</p> <p>The permissible nesting depth for subprograms is 2 subprogram levels.</p>

Number / Alarm	Cause	Counter-measure
A225 Status of collision monitoring select. not allowed	<p>The decoded NC block contains simultaneous selection and deselection of collision monitoring (G96/G97).</p> <p>Example: N1 G96 G97 X100</p> <p>The NC program number and NC block number in which the NC block decoder detected the error can be read out with the "output actual values - decoder error location" task.</p> <p>Effect: NC program execution is inhibited or aborted, the axis is brought to a standstill via the deceleration ramp.</p>	Correct the NC block.
A227 Negative overtravel violated	<p>The look-ahead function of the decoder has detected that the negative software limit switch will be crossed. See also error message "A195: Negative overtravel reached".</p> <p>The NC program number and NC block number in which the NC block decoder detected the error can be read out with the "output actual values - decoder error location" task.</p> <p>Effect: NC program execution is inhibited or aborted, the axis is brought to a standstill via the deceleration ramp.</p>	Correct the NC program. Check the machine data.
A228 Positive overtravel violated	<p>The look-ahead function of the decoder has detected that the positive software limit switch will be crossed. See also error message "A196: Positive overtravel reached".</p> <p>The NC program number and NC block number in which the NC block decoder detected the error can be read out with the "output actual values - decoder error location" task.</p> <p>Effect: NC program execution is inhibited or aborted, the axis is brought to a standstill via the deceleration ramp.</p>	Correct the NC program. Check the machine data.
A241 Table assignment changed	<p>The table assignment has been changed from 1 table to 2 tables or vice-versa.</p> <p>Effect: NC tables cannot be processed.</p>	Load the table again. Note: A table can only be loaded again if it is not selected. The warning is cleared automatically when the table has been successfully loaded.
A242 Table 1 invalid	<p>Table 1 was not loaded correctly or has been reset.</p> <p>Effect: Table 1 cannot be processed.</p>	Load table 1 again. Note: Table 1 can only be loaded again if it is not selected. The warning is cleared automatically when table 1 has been successfully loaded.
A243 Table 2 invalid	<p>Table 2 was not loaded correctly or has been reset.</p> <p>Effect: Table 2 cannot be processed.</p>	Load table 2 again. Note: Table 2 can only be loaded again if it is not selected. The warning is cleared automatically when table 2 has been successfully loaded.

Table 12-2 Alarm numbers, causes and their counter-measures

12.3 Fatal errors (FF)

Fatal errors are serious hardware or software errors which no longer permit normal operation of the unit. They only appear on the PMU in the form "FF<No>". The software is re-booted by actuating any key on the PMU.

Number / Fault	Cause	Counter-measure
FF01 Time slot overflow	A time slot overflow which cannot be remedied has been detected in the high-priority time slots.	- Reduce pulse frequency (P340) - Replace CU
FF04 RAM	A fault has occurred during the test of the RAM.	Replace CU
FF05 EPROM fault	A fault has occurred during the test of the EPROM.	Replace CU
FF13 Wrong firmware version	A version conflict between the firmware and the hardware has occurred.	- Replace firmware - Replace CU

Table 12-3 Fatal errors

13 Environmental Friendliness

Environmental aspects during the development

The number of components has been significantly reduced over earlier converter series by the use of highly integrated components and the modular design of the complete series. Thus, the energy requirement during production has been reduced.

Special significance was placed on the reduction of the volume, weight and variety of metal and plastic components.

Plastics components used

ABS:	PMU board, Siemens logo
PC / ABS:	Front cover MC Large
PA6:	Front cover MC, terminal strips, spacer bolts, fan impeller
PA6.6:	DC link terminal cover, through terminals, terminal strips, terminal blocks
PVC:	Optional card covers
PP:	PMU covers
PBTP:	Fan housing
PC (Makrolon):	Fan guides
HP2061 (Phenolharz):	Insulating plates
NOMEX:	Insulating paper

Halogen-containing flame retardants were, for all essential components, replaced by environmentally-friendly flame retardants.

Environmental compatibility was an important criterium when selecting the supplied components.

Environmental aspects during production

Purchased components are generally supplied in recyclable packaging materials (board).

Surface finishes and coatings were eliminated with the exception of the galvanized sheet steel side panels.

ASIC devices and SMD devices were used on the boards.

The production is emission-free.

Environmental aspects for disposal

The unit can be broken down into recyclable mechanical components as a result of easily releasable screw and snap connections.

The plastic components are to DIN 54840 and have a recycling symbol.

Units can be disposed of through certified disposal companies.

Addresses are available from your local Siemens partner.

14 Certificates

SIEMENS

Automation and Drives

Confirmation

Erlangen, 15.09.1998

This confirms that

Equipment

drive converter

- Type

SIMOVERT
MASTERDRIVES

- Order No.

6SE70xx-xxPxx ¹⁾

is manufactured in conformance with EN 60204 Section 6.2
(corresponds to DIN VDE 0113 Section 6.2).

1) See rating plate for complete type designation, serial number and technical data

This equipment fulfills the protection requirements against electric shock according to
DIN VDE 0106 Part 100 when the following safety rules are observed:

- Service work in operation is only permissible on a unit which is not live.
- The converter must be switched into a no-voltage condition and isolated from the supply when replacing any part/component.
- All panels and the DC link terminals must be closed during operation.

Thus, this equipment conforms to the appropriate regulations in Germany according to VBG 4 §2 (2) (VBG is a German regulatory body for safety-related issues).

The local operating regulations (e.g. EN 50110-1, EN 50110-2) must be observed when operating the equipment.

A&D DS A P1



Mickal



SIEMENS

Automation and Drives

Test Certificate

Erlangen, 15.09.1998

Equipment

drive converter

• Type**SIMOVERT
MASTERDRIVES****• Order No.****6SE70xx-xxPxx ¹⁾**

The 100% inspection was performed according to test instructions
Motion Control 6SE70xx-xxPxx.

Test scope:

- | | |
|----------------------------------------|-----------------------------------------------------------------------------------------------------------------------------------------------|
| I. Protective conductor test | • According to DIN VDE 0411 |
| II. Insulation test | • Acc. to EN 50178, Section 9.4.5.2 and UL508/CSA 22.2-14.M 91, Section 6.8 |
| III. Function test
acc. to EN 50178 | • Initialization and start-up
• Customer terminals test
• Power section inspection
• Inspection of protection and monitoring devices |
| IV. RUN-IN | • Continuous test > 5 hours
ambient temperature 55 °C |
| V. Function test
acc. to EN 50178 | • see III. Function test |

The equipment complied with the test requirements.
The test results are documented within the test data base.

1) See rating plate for complete type designation, serial number and technical data

A&D DS A PE D P



Schlögel



SIEMENS

Factory certificate *

regarding electromagnetic compatibility

EMC 0998 / Motion Control

Manufacturer: Siemens Aktiengesellschaft
Group Automation and Drives
Business Division Variable-speed drives
Sub-Division AC drive systems
Address: P.O. Box 3269
D-91050 Erlangen
Product name: SIMOVERT
Type 6SE70xx-xxPxx ¹⁾

When correctly used, the designated product fulfills all the requirements of Directive 89/336/EEC regarding electromagnetic compatibility.

We confirm the conformance of the above designated product with the Standards:

EN 61800-3 10-1996

EN 61000-4-2 (old IEC 801-2)

EN 61000-4-4 (old IEC 801-4)

EN 61000-4-5 (old IEC 801-5)

IEC 1000-4-3 (old IEC 801-3)

Note:

These instructions relating to EMC-correct installation, correct operation, connecting-up conditions and associated instructions in the product documentation supplied must be observed.

1) See rating plate for complete type designation, serial number and technical data

Erlangen, 15.09.1998



H. Mickal
A&D DS A P1



*) Acc. to EN 10204 (DIN 50049)

This declaration does not guarantee any features

Bisher sind folgende Ausgaben erschienen:

Ausgabe	Interne Sachnummer
AA	475 901 4170 76 J AA-74
AB	475 901 4170 76 J AB-74
AC	475 901 4170 76 J AC-74

Ausgabe AC besteht aus folgenden Kapiteln:

Kapitel		Änderungen	Seitenzahl	Ausgabedatum
1	Definitionen und Warnungen	überarbeitete Ausgabe	4	10.98
2	Beschreibung	überarbeitete Ausgabe	1	10.98
3	Erstinbetriebsetzung	überarbeitete Ausgabe	2	10.98
4	Transportieren, Lagern, Auspacken	überarbeitete Ausgabe	1	10.98
5	Montage	überarbeitete Ausgabe	8	10.98
6	EMV-gerechter Aufbau	überarbeitete Ausgabe	2	10.98
7	Anschließen	überarbeitete Ausgabe	11	10.98
8	Parametrierung	überarbeitete Ausgabe	27	10.98
9	Wartung	überarbeitete Ausgabe	3	10.98
10	Formieren	überarbeitete Ausgabe	2	10.98
11	Technische Daten	überarbeitete Ausgabe	7	10.98
12	Störungen und Warnungen	überarbeitete Ausgabe	33	10.98
13	Umweltverträglichkeit	überarbeitete Ausgabe	1	10.98
14	Bescheinigungen	überarbeitete Ausgabe	3	10.98

The following editions have been published so far:

Edition	Internal Item Number
AA	475 901 4170 76 J AA-74
AB	475 901 4170 76 J AB-74
AC	475 901 4170 76 J AC-74

Version AC consists of the following chapters:

Chapter		Changes	Pages	Version date
1	Definitions and warnings	reviewed edition	4	10.98
2	Description	reviewed edition	1	10.98
3	First Start-up	reviewed edition	2	10.98
4	Transport, Storage, Unpacking	reviewed edition	1	10.98
5	Installation	reviewed edition	8	10.98
6	Installation in Conformance with EMC Regulations	reviewed edition	2	10.98
7	Connecting-up	reviewed edition	11	10.98
8	Parameterization	reviewed edition	27	10.98
9	Maintenance	reviewed edition	3	10.98
10	Forming	reviewed edition	2	10.98
11	Technical Data	reviewed edition	7	10.98
12	Faults and Warnings	reviewed edition	31	10.98
13	Environmental friendliness	reviewed edition	1	10.98
14	Certificates	reviewed edition	3	10.98