

Overwhelmingly stable

Precise measurements on the order of 1/100 mm **0.0003 inch***
*HG-C1030(-P)

Excellent level detection performance

Repeatability: 10 μm *HG-C1030(-P)

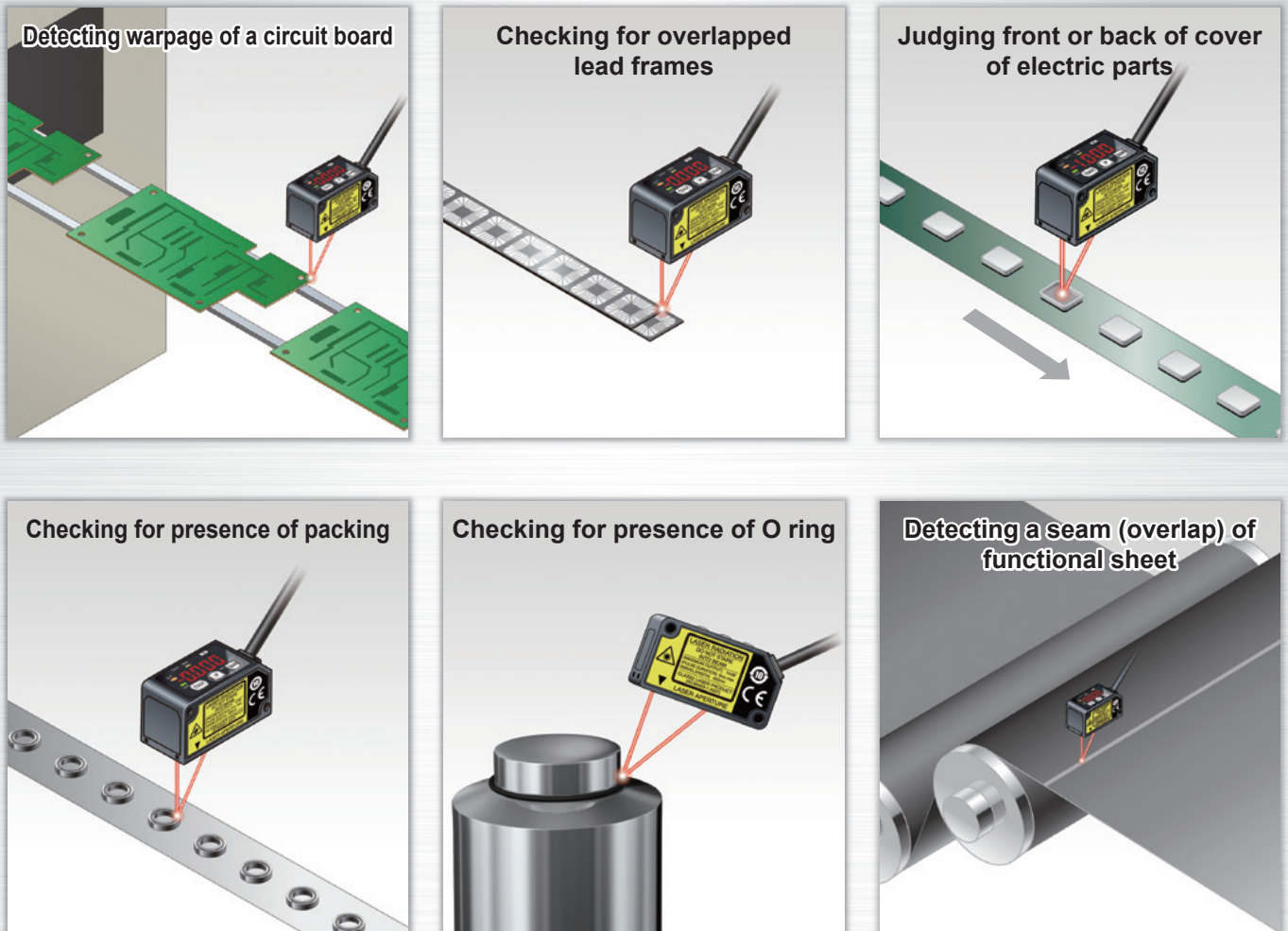

Fitted with a precise CMOS image sensor and an original algorithm

Thanks to a precise CMOS image sensor, it is now possible to perform highly precise measurements in the order of 1/100 mm **0.0003 in.** The existing adjustable range reflective sensors cannot achieve such accuracy.

Example: HG-C1030(-P)

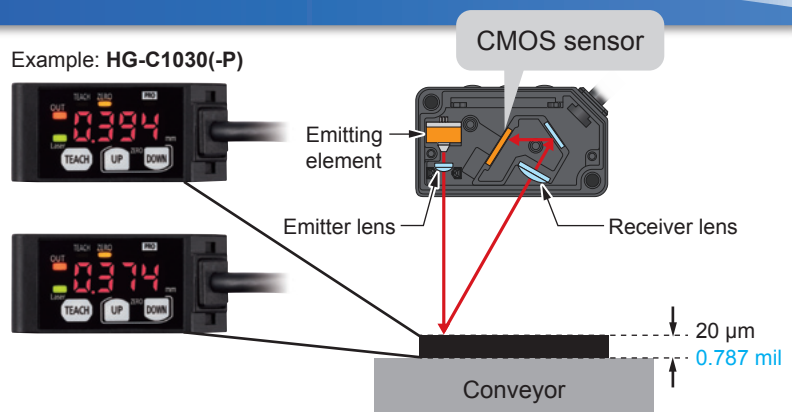

HG-C SERIES

Compact

The smallest CMOS laser sensor in the industry*
 *Based on research conducted by our company as of May 2015

Indicates real measurements

Linearity: $\pm 0.1\%$ F.S. *HG-C1030(-P) / HG-C1050(-P) / HG-C1100(-P)

Compact and light-weight

W20 × H44 × D25 mm, 35 g approx. (excluding the cable)

Long distance measurement

Measurement center distance: 400 mm *HG-C1400(-P), 200 mm *HG-C1200(-P)

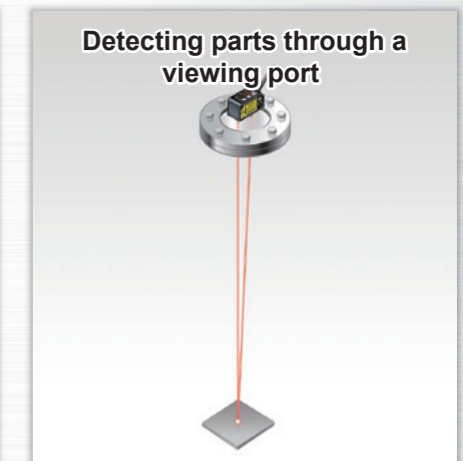
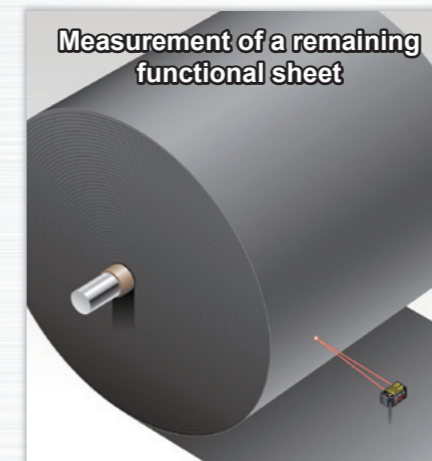
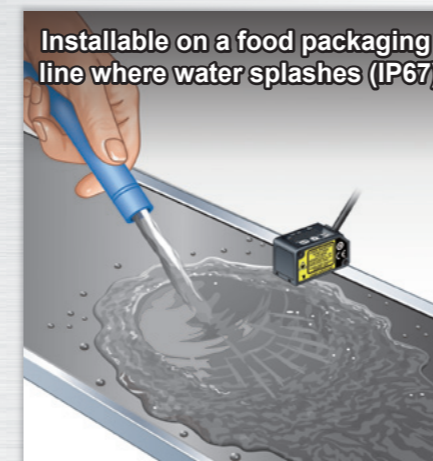
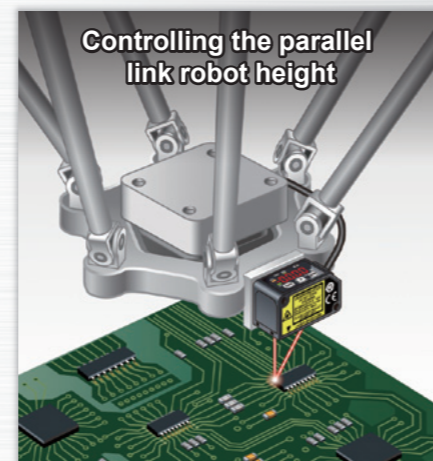
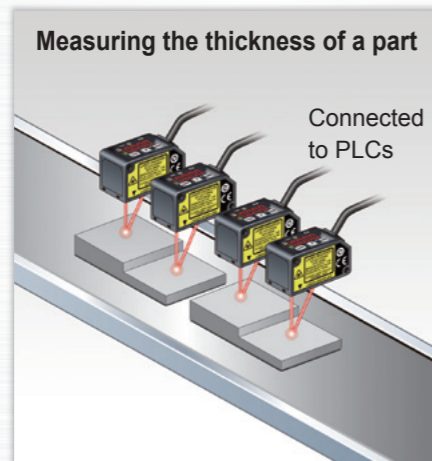
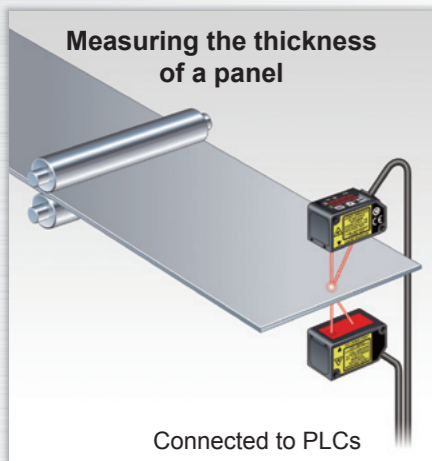
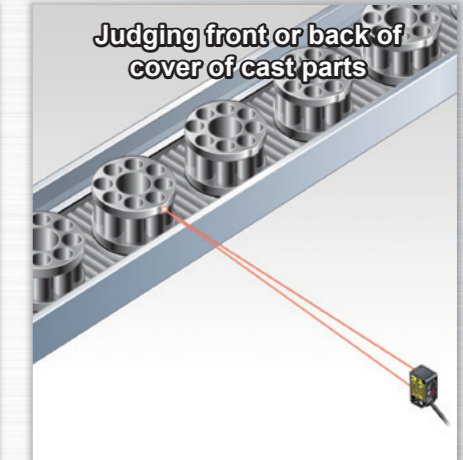
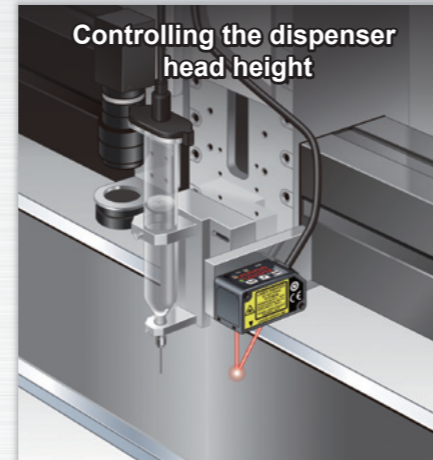
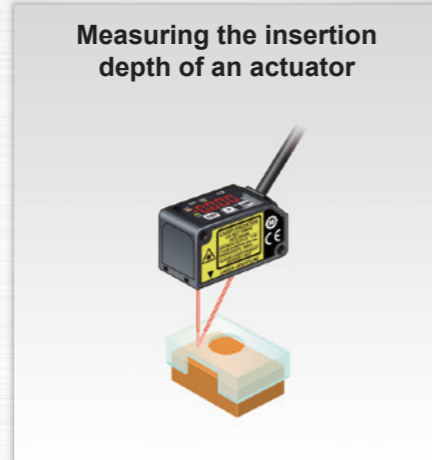
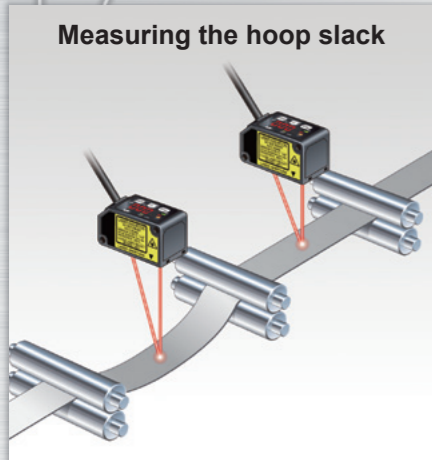

Remove water droplets on detection surface to achieve correct measurement.

Equipped with 0 to 5 V analog output and 4 to 20 mA analog current output

The value can be measured with a distance measurement sensor.

Linearity: $\pm 0.1\%$ F.S.*
 Temperature characteristics: 0.03%F.S./°C

The sensor not only indicates measured values in mm but also produces analog outputs. Various calculations and storage (logging) can be performed when output is taken into a PLC + analog unit.

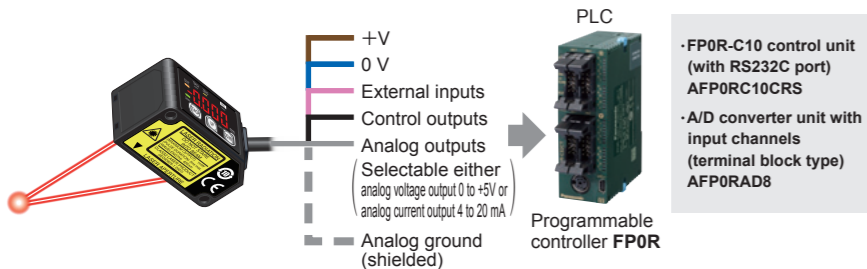

*HG-C1030(-P) / HG-C1050(-P) / HG-C1100(-P)

Linearity characteristics [Typical example: HG-C1030(-P)]

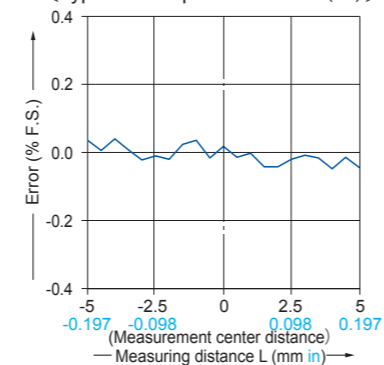

A new optical system with a built-in mirror

In general, more accurate and stable measurements can be obtained by increasing the optical path length between the light-receiving part and the light receiving element (CMOS), but this also increases the sensor depth and the sensor body gets bigger.

The HG-C series sensors incorporating a new optical system with a built-in mirror provides smaller sensor depth as well as higher measurement accuracy equivalent to displacement sensors.

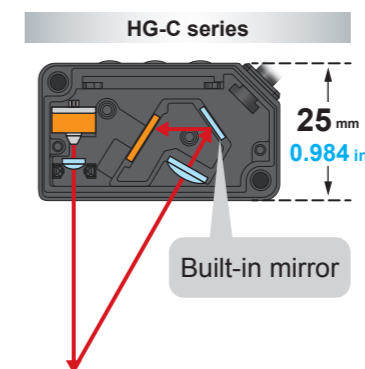

An aluminum die-cast casing protects from strain and heat

A light-weight but strong die-cast aluminum casing has been adopted. A compact, solid body casing reduces the impact of strain and heat on the measurement accuracy.

Aluminum die-cast casing

